

GROUP Safety Recall Campaign	MODEL 2011-2014MY Optima (QF/TF) 2012-2014MY Sorento (XMa) 2011-2013MY Sportage (SL)
NUMBER SC147	DATE June 2017

SAFETY RECALL CAMPAIGN

SUBJECT: THETA II ENGINE INSPECTION AND/OR REPLACEMENT (SC147)

This bulletin provides the procedure to inspect, and if necessary, replace the engine long block assembly on the following vehicles:

- All 2011-2013MY Optima (QF/TF) vehicles equipped with the 2.4L Gasoline Direct Injection (GDI) and 2.0L Turbocharged GDI (T-GDI) engines produced from August 12, 2010 through September 27, 2013;
- All 2014MY Optima (QF) vehicles equipped with the 2.4L Gasoline Direct Injection (GDI) and 2.0L Turbocharged GDI (T-GDI) engines produced at KMMG from August 28, 2013 through May 15, 2014;
- All 2012-2014MY Sorento (XMa) vehicles equipped with the 2.4L Gasoline Direct Injection (GDI) engines produced from April 19, 2011 through February 10, 2014; and
- All 2011-2013MY Sportage (SL) vehicles equipped with the 2.0L Turbo Gasoline Direct Injection (T-GDI) engines produced from December 30, 2010 through August 30, 2013.

Metal debris may have been generated from factory machining operations of the engine crankshaft and may not have been completely removed from the crankshaft's oil passages during the cleaning process. It was also determined that the additional machining processes of the crankpins may have caused uneven surface roughness. These combined conditions can restrict oil flow to the bearings increasing the potential for premature bearing wear.

A worn connecting rod bearing will produce a cyclic knocking noise from the engine and may also result in the illumination of the vehicle's engine warning and/or oil pressure lamp on the instrument panel. If the warnings are ignored and the vehicle is continued to be driven, the bearing may fail and the vehicle could stall while in motion. An engine stall at higher speeds can increase the risk of a crash.

Follow the procedure outlined in this bulletin to inspect, and if necessary, replace the engine long block assembly. Before conducting the procedure, verify the vehicle is included in the list of affected VINs.

* NOTICE

There is no charge to the vehicle owner for this repair. Under applicable law, you may not sell or otherwise deliver any affected new vehicle until it has been repaired pursuant to the procedures set forth in this bulletin.

File Under: <Safety Recall Campaign>

Circulate To: General Manager Service Manager Parts Manager
 Service Advisors Technicians Body Shop Manager Fleet Repair

*** NOTICE**

To ensure complete customer satisfaction, always remember to refer to WebDCS Warranty Coverage (validation) Inquiry Screen (Service → Warranty Coverage → Warranty Coverage Inquiry) for a list of any additional campaigns that may need to be performed on the vehicle before returning it to the customer.

IMPORTANT - Special Service Tool / Part Availability:

1. As previously announced to Dealer Service Managers, one (1) each of the SST kits as well as the software update (via internet update released on 6/1/2017) necessary to prepare the KDS tablets for use during the engine inspections were shipped to arrive at the dealership on June 1st.
2. Should a vehicle fail the SC147 engine inspection and requires a new long block assembly to repair, please set the vehicle aside and arrange alternate transportation for the customer until a replacement engine becomes available.

Inspection Procedure:

1. Prior to inspection, ensure the KDS is fully charged and has the latest update.
 - Engine oil level should be at the "FULL" mark. Top off with 5W-30 if required.
 - Test requires the engine to be in satisfactory running condition and able to idle normally.
 - Engine coolant temperature should be above minimum test temperature: 185°F (85°C).

If the engine's running condition is poor due to issues unrelated to a connecting rod knocking noise (faulty sensors, intake/exhaust manifold leak, catalytic converter, etc.), diagnose and repair prior to performing this inspection procedure.

2. With the engine off, remove the dipstick (A).

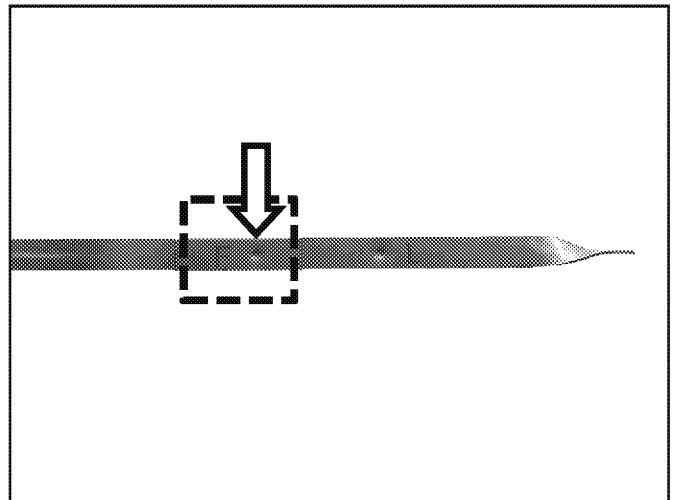
*** NOTICE**

Engine cover removed in images for demonstration-only purposes.

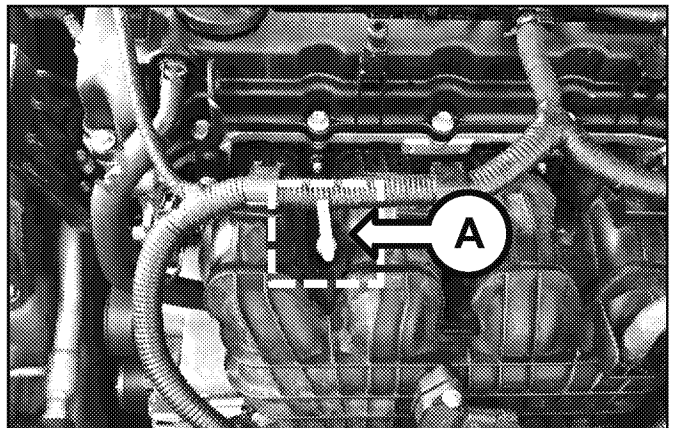

SUBJECT: THETA II ENGINE INSPECTION AND/OR REPLACEMENT (SC147)

3. Insert the engine noise tester SST adapter (B) into the dipstick tube and start the engine.

*** NOTICE**

Ensure the adapter (B) is properly inserted into the dipstick tube and avoid contact with the intake manifold.

[Click here for a video tutorial of the Inspection Procedure.](#)

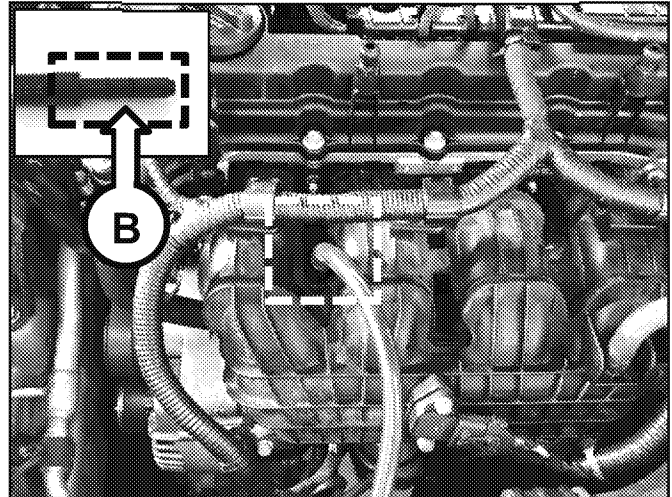
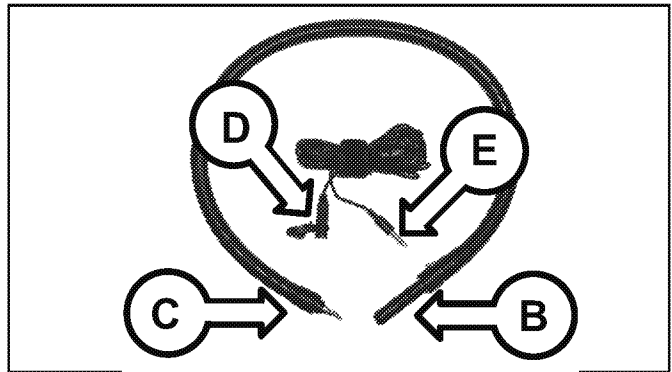

4. Connect the 3.5 mm male end of the engine noise tester SST (C) to the 3.5 mm female end of the extension cable (D).

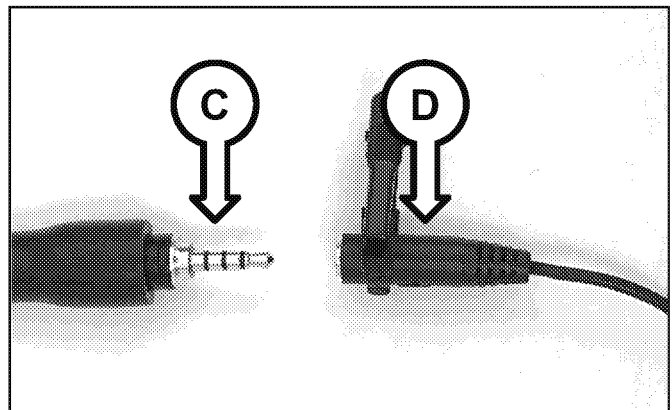

5. Attach the SST clip of the extension cable (D) to the hood latch.

CAUTION

Make sure to route the extension cable away from moving parts (pulleys, fan, and belts and be careful not to get it pinched between door and body or window, etc.).

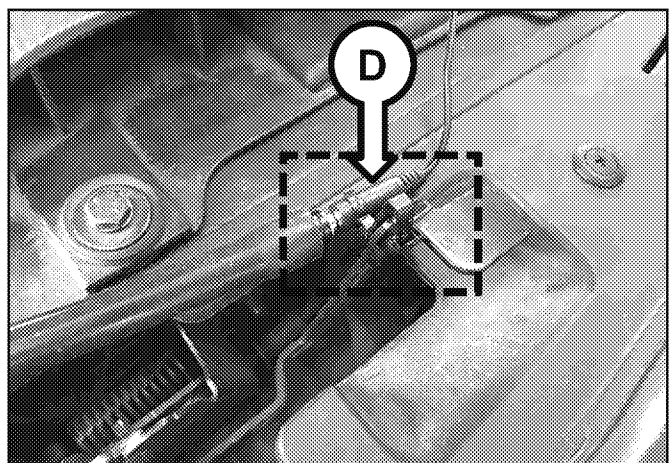

SUBJECT: THETA II ENGINE INSPECTION AND/OR REPLACEMENT (SC147)

- Connect the 3.5 mm male end (E) of the extension cable to the headphone port located at the upper left corner (KDS version 1.0) or at the bottom of the tablet (KDS version 2.0), then start and idle the engine.

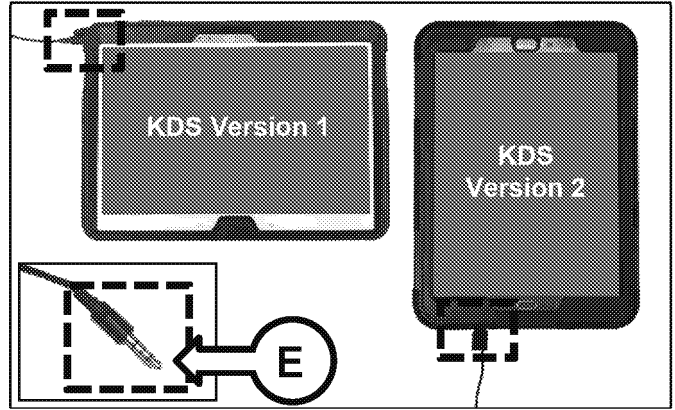

- Connect the VCI-II to the OBD-II connector and launch the KDS application from the KDS tablet home page.



- Confirm communication with VCI (F) and then configure the vehicle (G) using the **AUTO VIN (H)** feature.

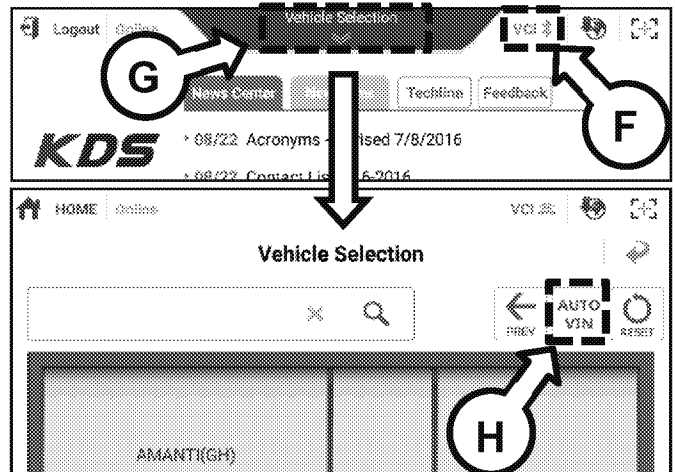

- Drag up the "More" tab from the lower screen of the KDS and select "Special Inspection".

*** NOTICE**

If the vehicle model/model year does not qualify for this campaign, a message will pop up; if so, verify that the vehicle is included in the list of affected VINs for SC147.

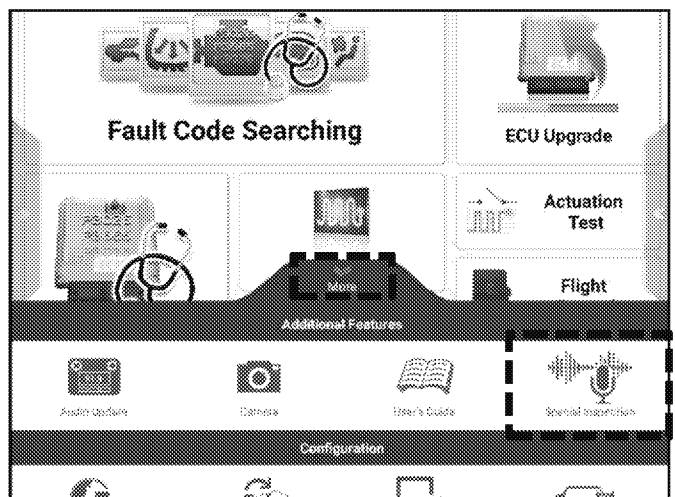

SUBJECT: THETA II ENGINE INSPECTION AND/OR REPLACEMENT (SC147)

10. Complete the vehicle information form on the screen:

- Mileage
- RO number
- Select “Verify” to verify the VIN

Note: VIN must be verified with the “Verify” function in order to proceed to the next step.

Select “Next” to continue.

11. Confirm that all of the pre-inspection items listed on the screen are true:

- Engine Oil Level – Normal
- Coolant Level – Normal
- Engine Cover – Installed
- Driver Window - Opened
- A/C & Blower Motor – OFF
- Audio & All Accessories – OFF
- Engine – Warm up (185°F or higher)
- Insert “A” into dipstick tube
- Connect “B” part at tablet headphone port

Select “Next” after checking items mentioned above.

12. The program will automatically check the engine sensors’ data. Select the “Next” button if all the conditions are satisfied.

- Engine Coolant Temperature: 185°F or higher
- A/C Request to ECU: OFF

Note: If the test item result is “NOT GOOD”, correct the condition then select “Refresh Data”.

Test Item	Value	Unit	Result
Engine Coolant Temperature	185.0	F	GOOD
A/C Request to ECU	OFF	-	GOOD

SUBJECT: THETA II ENGINE INSPECTION AND/OR REPLACEMENT (SC147)

13. Follow the instructions on the screen then select “Next”.

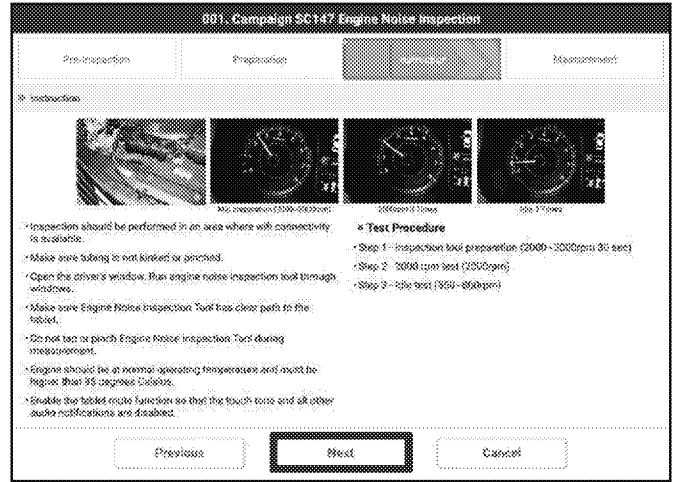

14. Prior to the initial measurement, the program will automatically check if the engine noise tester is installed and operating correctly at engine idle and perform an internal diagnosis.

Begin the second part of the engine noise tester check by selecting “Start”.

*** NOTICE**

If the measured noise level is too low or abnormally high, an engine noise tester inspection message will pop up. Check and correct as necessary and start again.

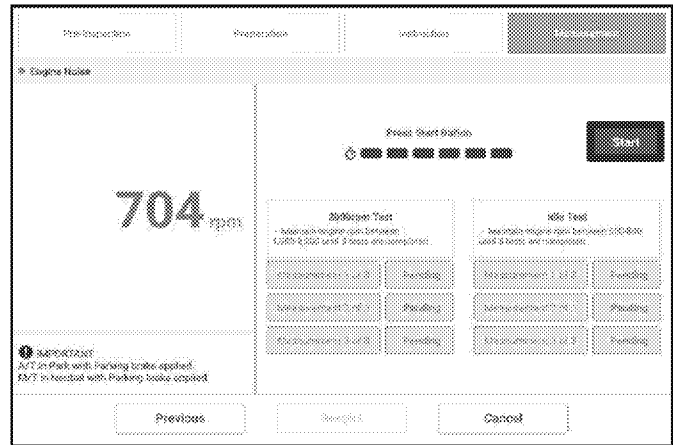

15. With the vehicle in Park (A/T) / Neutral (M/T), increase and maintain the engine speed at 2000-3000 RPM for thirty (30) seconds.

The program will automatically proceed to the next step when the engine noise tester is ready.

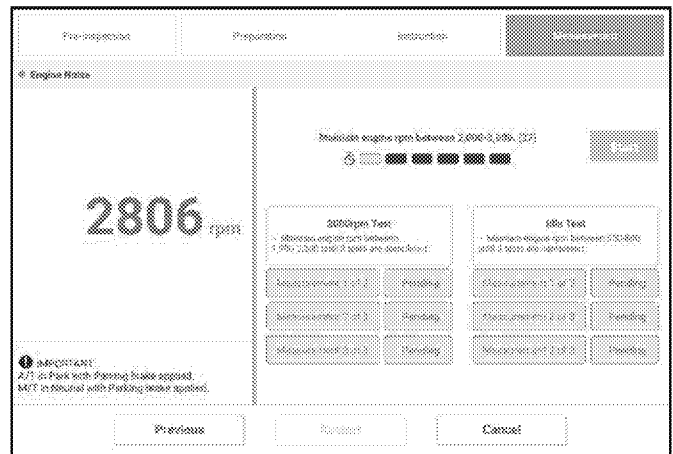

SUBJECT: THETA II ENGINE INSPECTION AND/OR REPLACEMENT (SC147)

16. With the vehicle in Park (A/T) / Neutral (M/T), begin the “2000rpm Test” by increasing and maintaining engine speed between 1900-2100 (2.4L) or 1900-2200 (2.0T) RPM until all three (3) measurements are complete.

*** NOTICE**

Once the RPM is in the specified range, the time count (green bars) will be initialized.

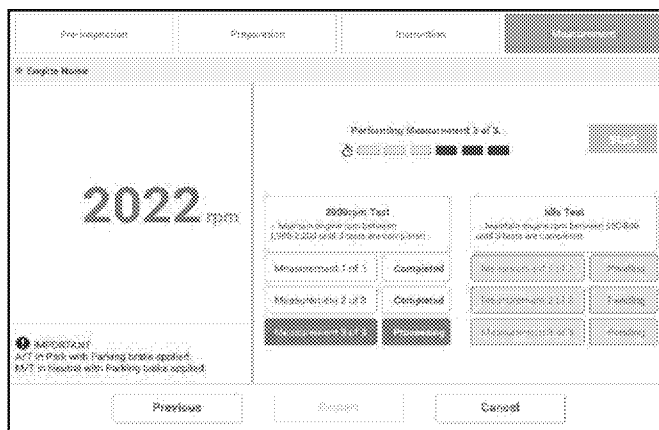

17. When the “2000rpm Test” is complete, release the accelerator pedal so that engine maintains idle state for the “Idle Test”.
18. The “Idle Test” will automatically begin. Keep the engine at idle and wait until all three (3) measurements are complete.

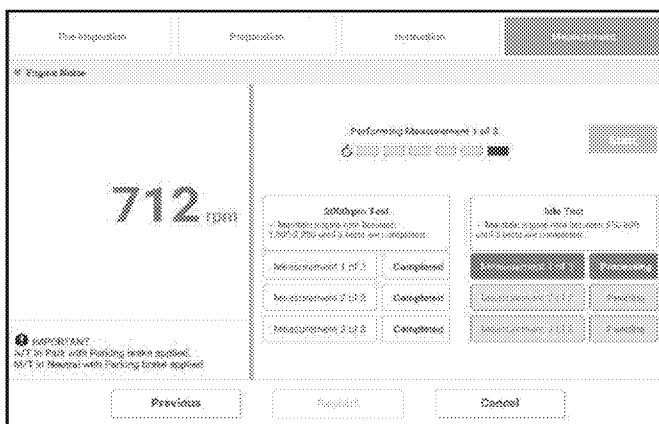

19. After the completion of the engine noise inspection, the KDS will automatically generate/display a “PASS” or “NO PASS” result.

- If the inspection result is “PASS,” proceed to the next step.
- If the inspection result is “NO PASS,” set the vehicle aside and arrange alternate transportation for the customer while awaiting replacement engine availability.

Note: An additional Service Procedure will be provided as an update to this bulletin, at the time of replacement engine availability.

- If the inspection result is “RETEST”, repeat the inspection procedure starting from step 9 (first check for possible reasons like correct tool placement, interference with vibrating components, loose connections, etc.).

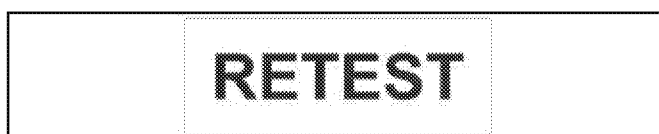
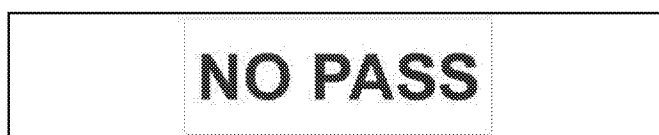

SUBJECT: THETA II ENGINE INSPECTION AND/OR REPLACEMENT (SC147)

20. Select “Finish” to complete the engine noise inspection. Ensure the KDS is connected to the internet and the “Special Inspection” KDS application is open to automatically submit the results to the Kia Server. To save and/or print the results as PDF, select “Print”.

If the KDS is not connected to the internet, up to five (5) results will stay pending in the queue until the KDS is connected to the internet with the “Special Inspection” application open.

Note: The five (5) pending results must be submitted before a sixth (6th) test can be conducted.

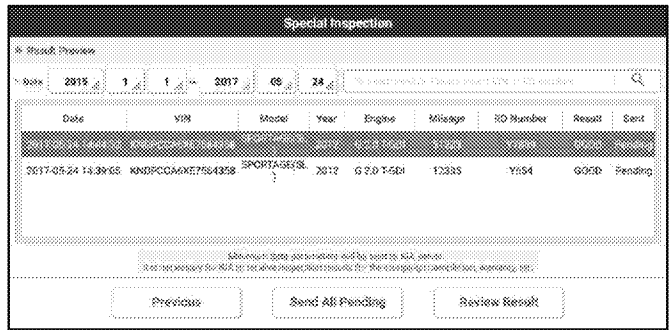
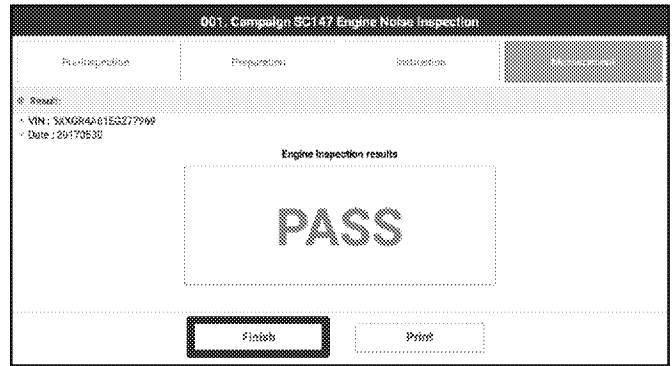

21. Disconnect the engine noise tester from the KDS and carefully remove the adapter (B) from the dipstick tube by grasping the engine noise tester adapter.

22. For 2011-13MY vehicles only: If the vehicle is equipped with a YELLOW dipstick, discard the dipstick and replace it with a new ORANGE one.

*** NOTICE**
 If the vehicle is equipped with a RED dipstick, replacement is not necessary.

On all vehicles with an inspection result of “PASS”: Change the oil and filter. Use the new (ORANGE) or verified (RED) dipstick to verify proper oil level after oil change and if applicable, reset the maintenance reminder on the instrument cluster.

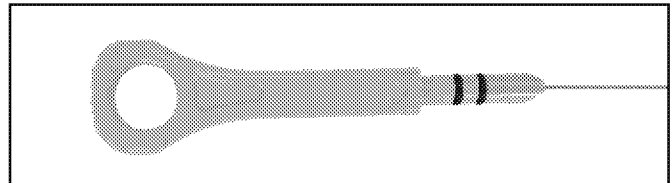

Yellow Dipstick

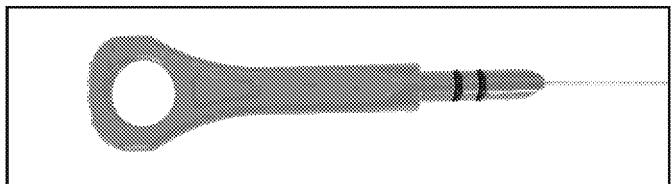

Orange Dipstick

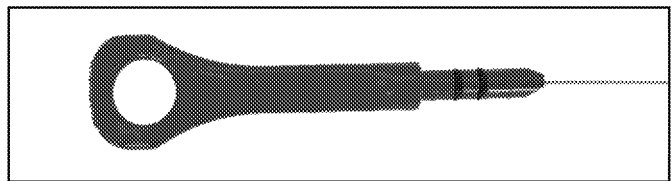

**Red Dipstick
 (NO REPLACEMENT REQUIRED)**

*** NOTICE**
 Should a vehicle fail the SC147 engine inspection and requires a new long block assembly to repair, please set the vehicle aside and arrange alternate transportation for the customer until a replacement engine becomes available.

SUBJECT: THETA II ENGINE INSPECTION AND/OR REPLACEMENT (SC147)**AFFECTED VEHICLE RANGE:**

Model	Production Date Range
2011-2013MY Optima (QF/TF)	August 12, 2010 through September 27, 2013
2014MY Optima (QF)	August 28, 2013 through May 15, 2014
2012-2014MY Sorento (XMa)	April 19, 2011 through February 10, 2014
2011-2013MY Sportage (SL)	December 30, 2010 through August 30, 2013

REQUIRED TOOLS:

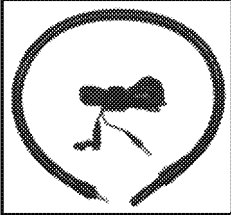
Tool Name	Tool Part No.	Figure	Comments
Engine Noise Tester SST	GIT1XTDCP005		Auto-shipped to Dealers. For replacements, contact Snap-On Business Solutions at (888) 542-1011.

REQUIRED PARTS:

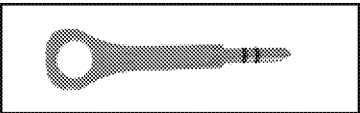
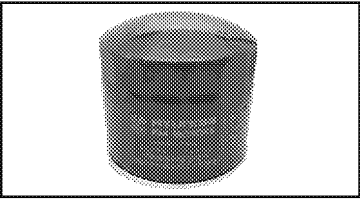
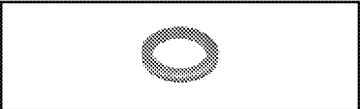
Part Name	Engine	Part Number	Figure
Dipstick	2011-2013MY 2.4GDI and 2.0T-GDI	26611 2G050QQK	
Oil Filter	All 2.4GDI and 2.0T-GDI	26300 35504	
Drain Plug Washer	All 2.4GDI and 2.0T-GDI	21513 23001	

WARRANTY INFORMATION:**N Code: N99 C Code: C99**

Model	Claim Type	Causal P/N	Qty.	Repair Description	Labor Op Code	Op Time	Replacement P/N	Qty.
Optima (QF)	R	23060 2G400	0	(SC147) Engine Noise Inspection PASS & LOF	171A29I1	0.7 M/H	26300 35504	1
							21513 23001	1
				(SC147) Engine Noise Inspection PASS , Dipstick Replacement, & LOF	171A29I0	0.7 M/H	26611 2G050QQK	1
							26300 35504	1
21513 23001	1							

SUBJECT: THETA II ENGINE INSPECTION AND/OR REPLACEMENT (SC147)

Model	Claim Type	Causal P/N	Qty.	Repair Description	Labor Op Code	Op Time	Replacement P/N	Qty.
Optima (TF)	R	23060 2G400	0	(SC147) Engine Noise Inspection PASS & LOF	171044I1	0.7 M/H	26300 35504	1
							21513 23001	1
				(SC147) Engine Noise Inspection PASS , Dipstick Replacement, & LOF	171044I0	0.7 M/H	26611 2G050QQK	1
							26300 35504	1
		21513 23001	1					
Sorento (XMa)	R	21020 2G010	0	(SC147) Engine Noise Inspection PASS & LOF	171A30I1	0.7 M/H	26300 35504	1
							21513 23001	1
				(SC147) Engine Noise Inspection PASS , Dipstick Replacement, & LOF	171A30I0	0.7 M/H	26611 2G050QQK	1
							26300 35504	1
		21513 23001	1					
Sportage (SL)	R	23060 2G400	0	(SC147) Engine Noise Inspection PASS & LOF	171045I1	0.7 M/H	26300 35504	1
							21513 23001	1
				(SC147) Engine Noise Inspection PASS , Dipstick Replacement, & LOF	171045I0	0.7 M/H	26611 2G050QQK	1
							26300 35504	1
		21513 23001	1					

NOTE: Use sublet code 'X1' with a maximum allowed amount of \$16.50 for engine oil reimbursement.

If an engine oil top-off is necessary before performing noise test as outlined in Step 1, use sublet code 'X2' for reimbursement of maximum of one (1) quart of oil (\$3.30 maximum), if applicable.

If any warrantable repairs are performed prior to performing this SC147 noise inspection as outlined in Step 1, please submit a separate claim under a new line using the same Repair Order used for the SC147 noise inspection.

*** NOTICE**

This Warranty Information will be updated when the Service Procedure for engine replacement is added in the near future (reference step 19 of this TSB).

For alternate transportation details, refer to Warranty Bulletin SC147.

*** NOTICE**

VIN inquiry data for this repair is provided for tracking purposes only. Kia retailers should reference SC147 when accessing the WebDCS system.