

## CERTAIN 2018-2020 MODEL YEAR EXPEDITION AND NAVIGATOR VEHICLES — FRONT SEATBELT RETRACTOR DATE CODE INSPECTION

### SERVICE PROCEDURE

**IMPORTANT!** The Service Technician Specialty Training (STST) Competency 10 certification requirement, for U.S. market only, will be enforced starting with repair orders opened on or after April 1, 2024. Field Service Action (FSA) repairs will reject if the repairing technician is not certified in STST Competency 10 FSA. See Electronic Field Communication (EFC) 14251 for more details.

### Evaporator Drain Tube Inspection

**WARNING:** The vehicle should be cool enough to touch before performing this procedure.

1. Using an extension mirror through the Right Hand (RH) side of the engine compartment, inspect the evaporator drain tube for the presence of an elbow installed.

- Is there an elbow installed? See Figure 1 for correct location to inspect and Figure 2 for an example of the elbow installed.

Yes - Passes inspection. Proceed to Front Seatbelt Retractor Inspection procedure, on Page 6.

No - Does not pass inspection. Proceed to Step 2.

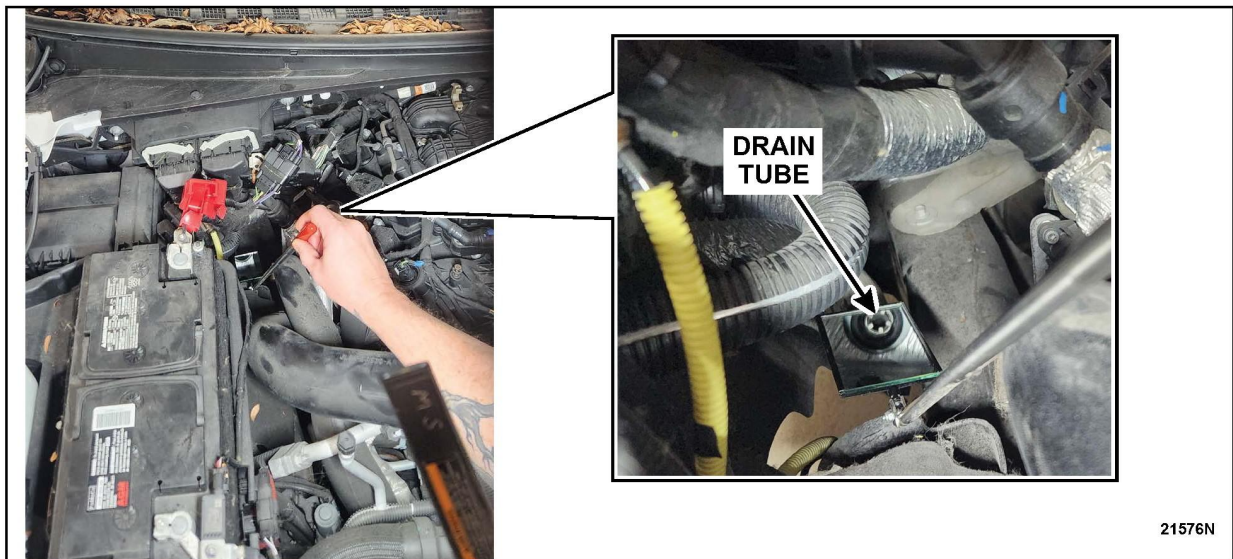

FIGURE 1

21576N





**FIGURE 2**

2. Raise the vehicle and remove the RH front tire.
3. Remove the RH front fender splash shield. Follow the Workshop Manual (WSM) procedures in Section 501-02.
4. Using needle nose pliers or equivalent, remove and discard the metal shield from the evaporator drain tube by bending the tabs away from the tube. See Figures 3 through 5.

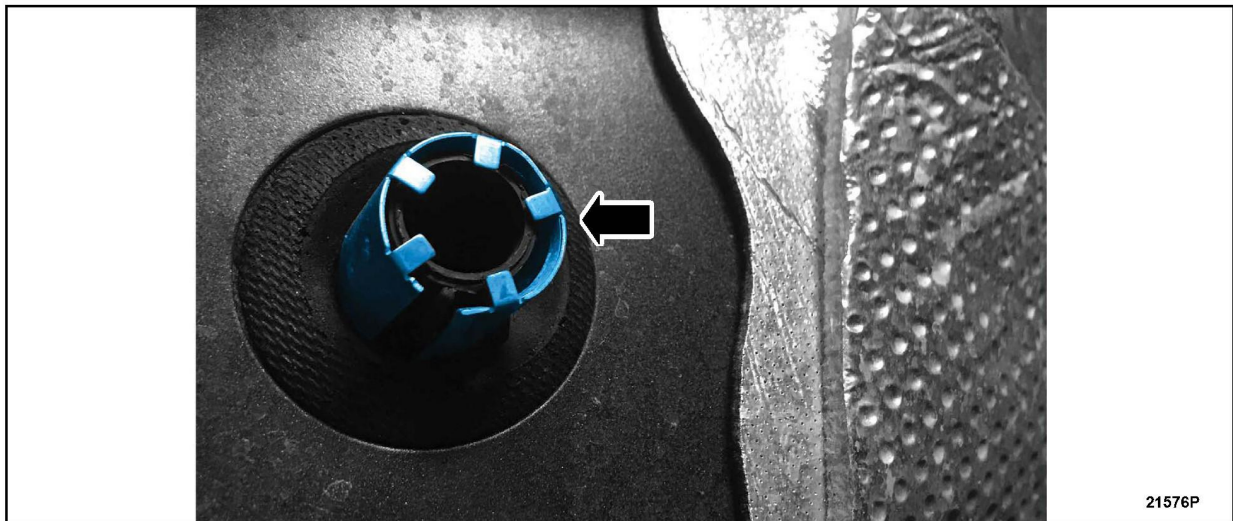

**FIGURE 3**



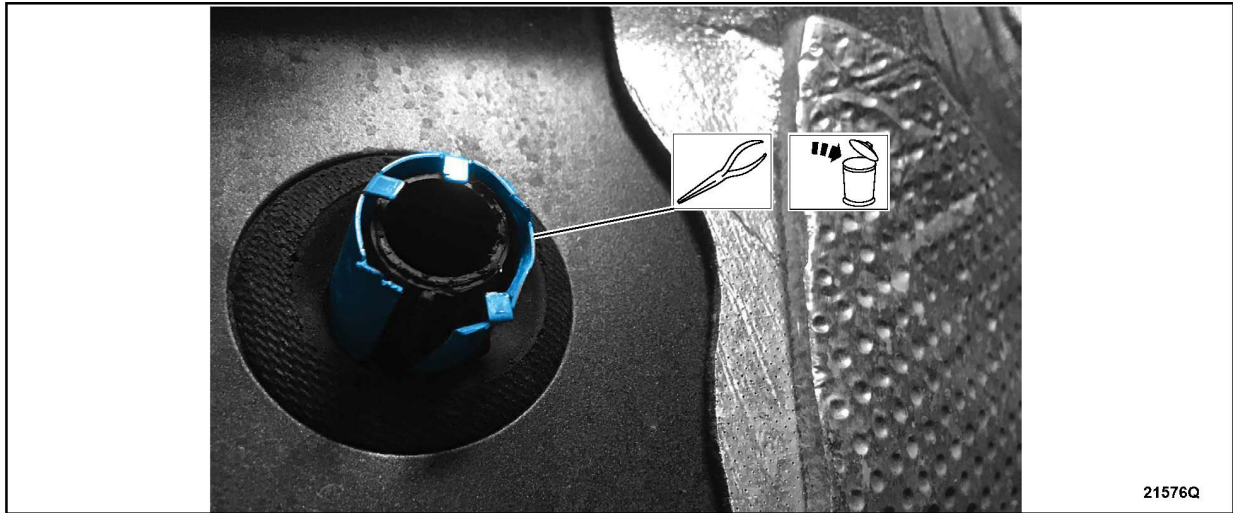

FIGURE 4



FIGURE 5



5. Lubricate the inside of the elbow with water. Install the short end of the elbow onto the drain tube. See Figures 6 and 7.



FIGURE 6

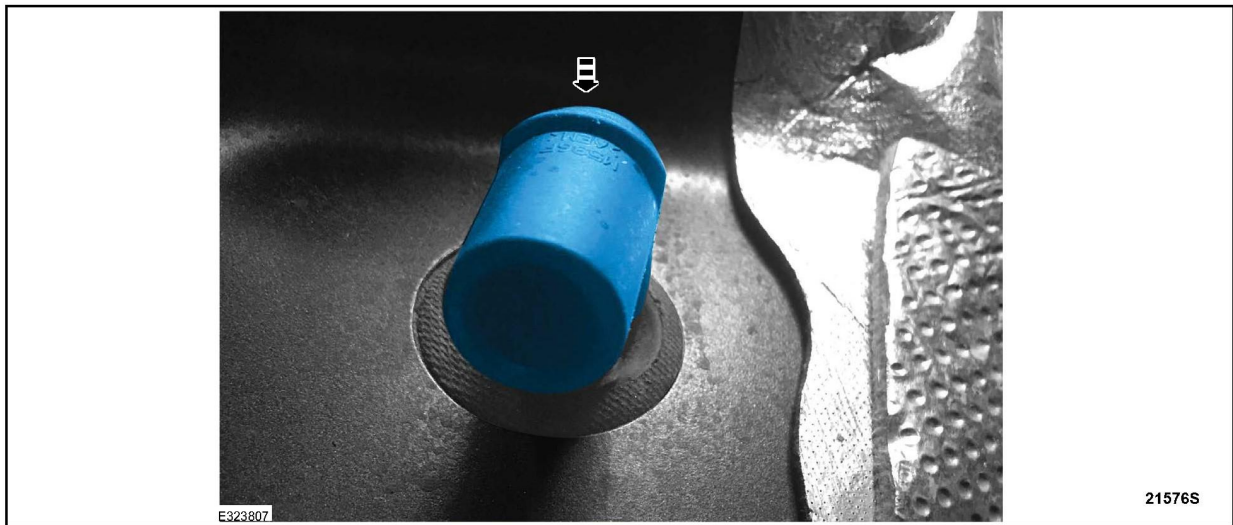

FIGURE 7



6. Clean the surface of the elbow, drain seal, and surrounding sheet metal with isopropyl alcohol or equivalent.
7. Apply heat shield tape over the elbow. See Figure 8.



**FIGURE 8**

8. Reassemble the vehicle by reversing Steps 2 and 3, then proceed to Front Seatbelt Retractor Inspection procedure, on Page 6.

**NOTE: Make sure to inspect the carpet for dampness and/or odor and service as necessary.**



## Front Seatbelt Retractor Inspection

1. Position the front door weatherstrip aside. See Figure 9.



FIGURE 9

2. Release the clips and remove the front door scuff plate trim panel. See Figure 10.

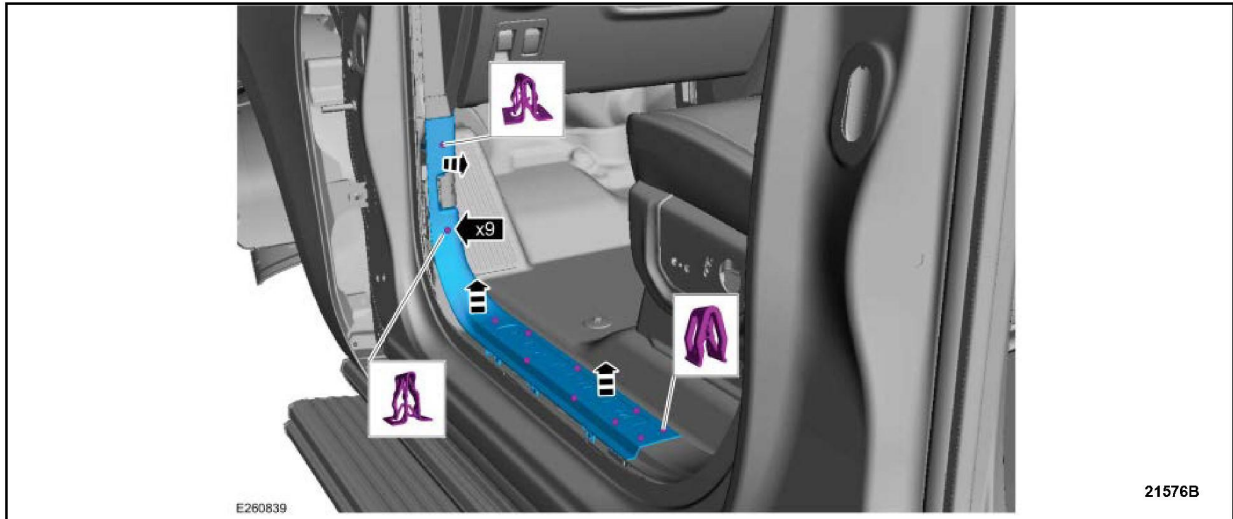
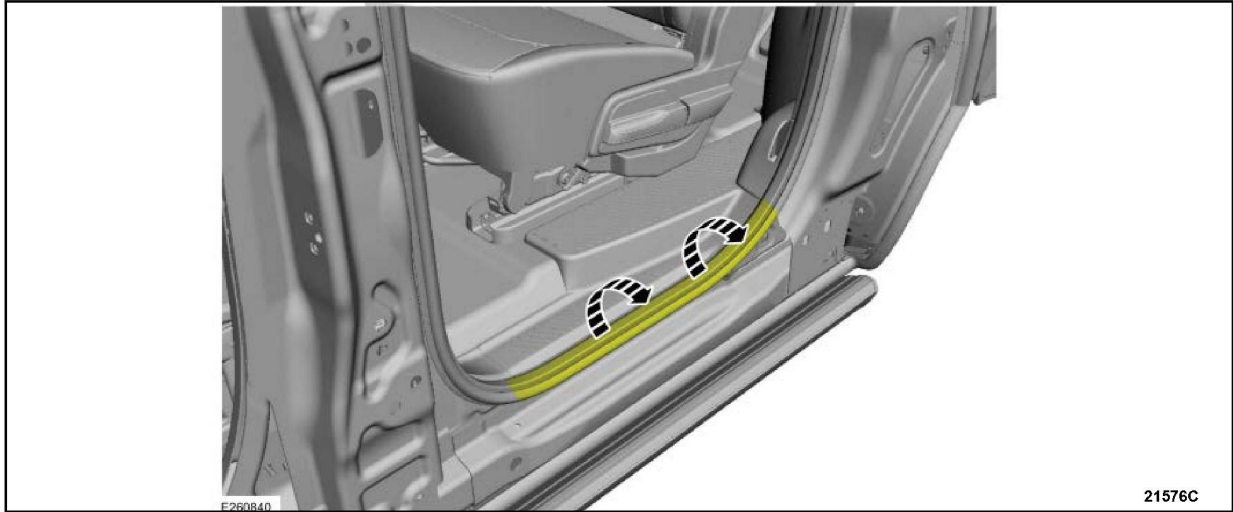

FIGURE 10



3. Position the rear door weatherstrip aside. See Figure 11.



**FIGURE 11**

4. Position the second row seat forward. See Figure 12.

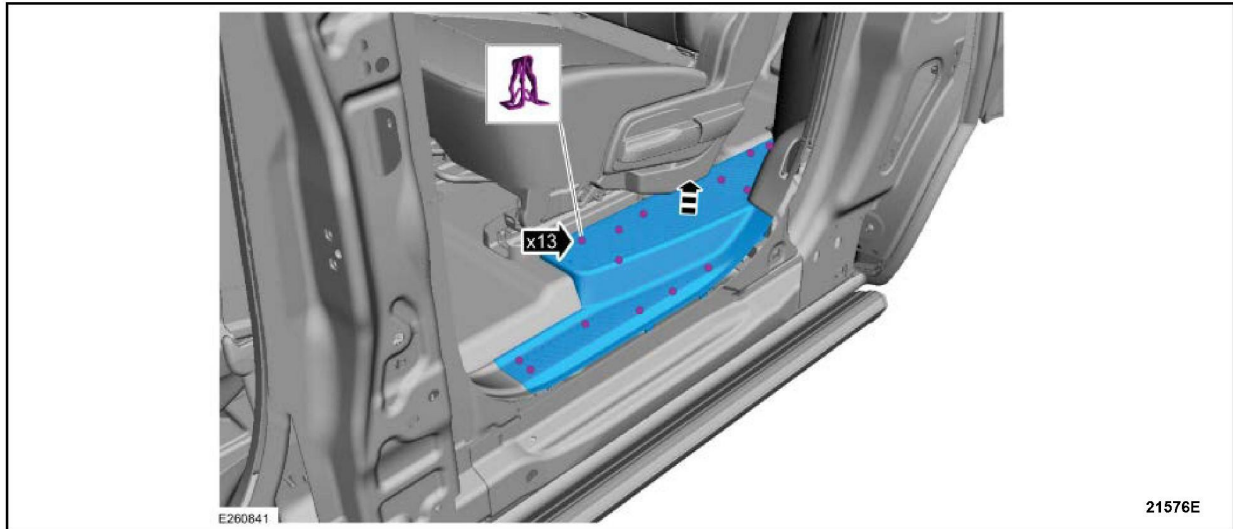

**FIGURE 12**



5. Release the clips and remove the rear door scuff plate trim panel. See Figure 13.

**NOTE:** Long wheelbase shown, short wheelbase similar.



**FIGURE 13**

6. Position the front door weatherstrip aside. See Figure 14.

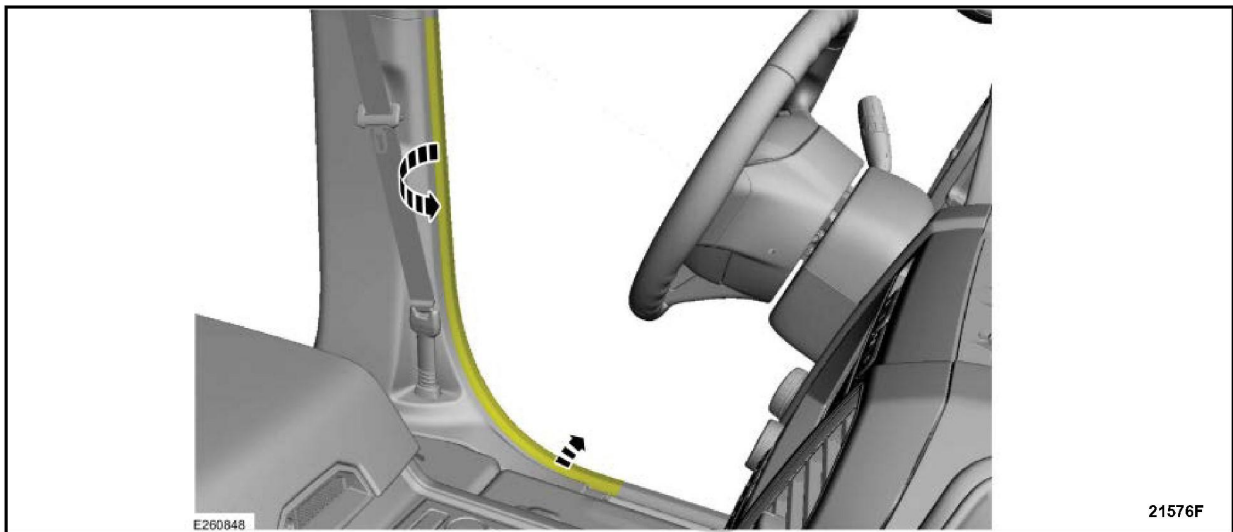

**FIGURE 14**



7. Position the rear door weatherstrip aside. See Figure 15.

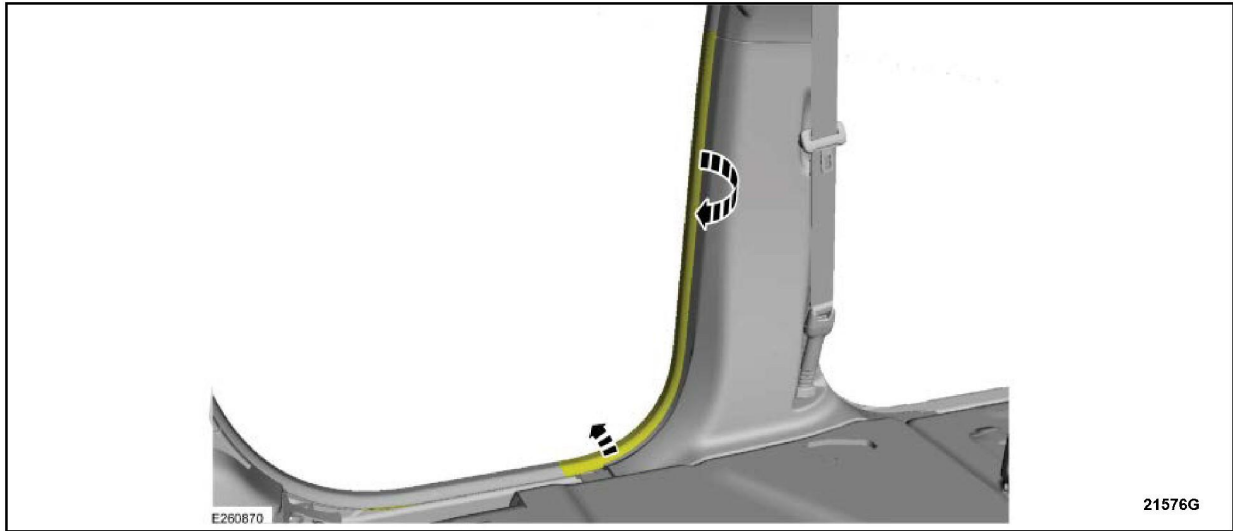

**FIGURE 15**

8. Press in on the release button and disconnect the front seatbelt retractor from the front seatbelt anchor pretensioner. See Figure 16.

- Use the General Equipment: Flat-Bladed Screwdriver

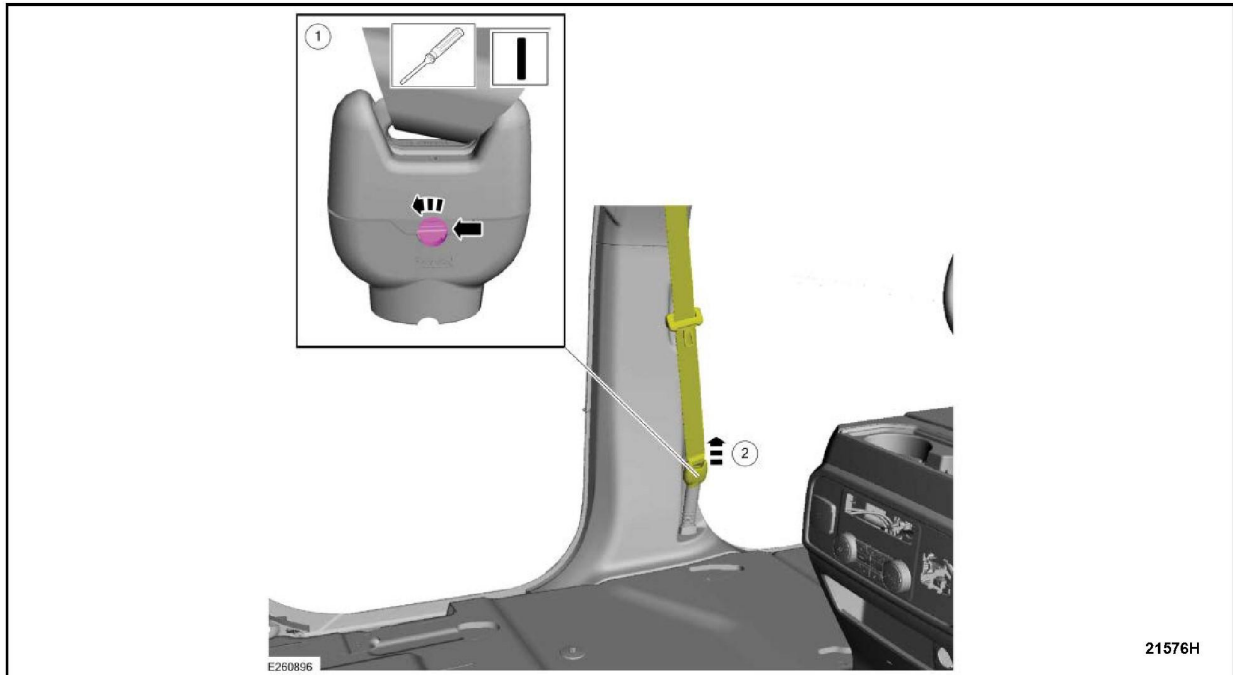

**FIGURE 16**



9. Press in on the sides of the front seatbelt anchor pretensioner boot, then lift up and remove the front seatbelt anchor pretensioner boot. See Figure 17.

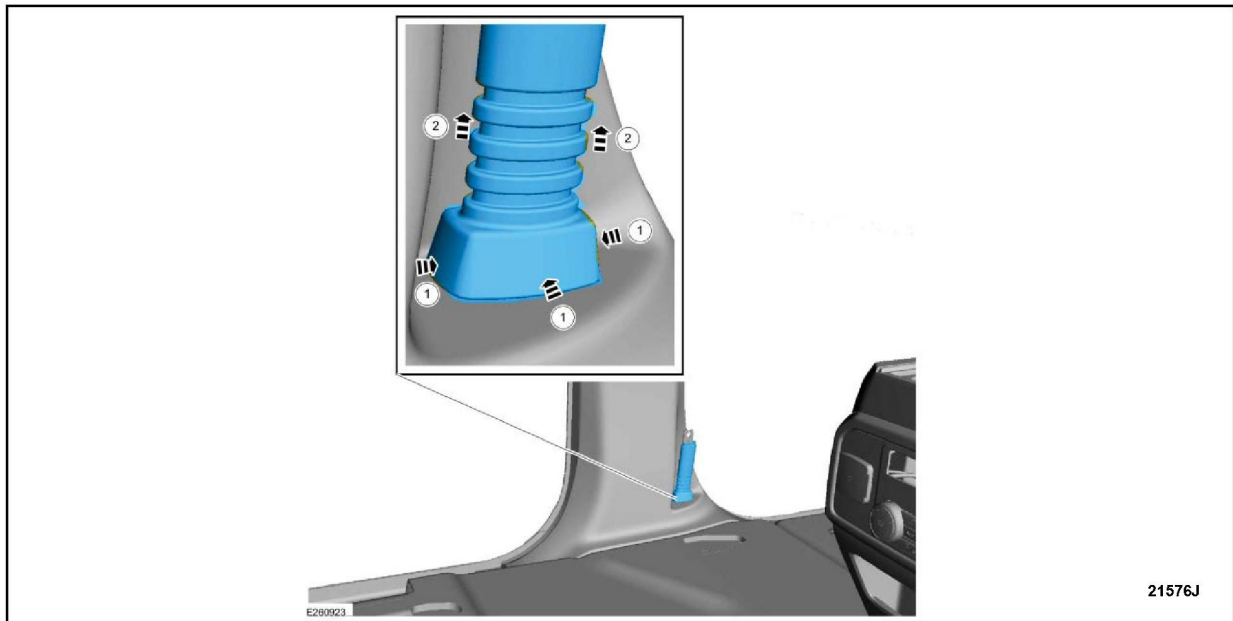

**FIGURE 17**

10. Release the clips and remove the lower B-pillar trim panel. See Figure 18.

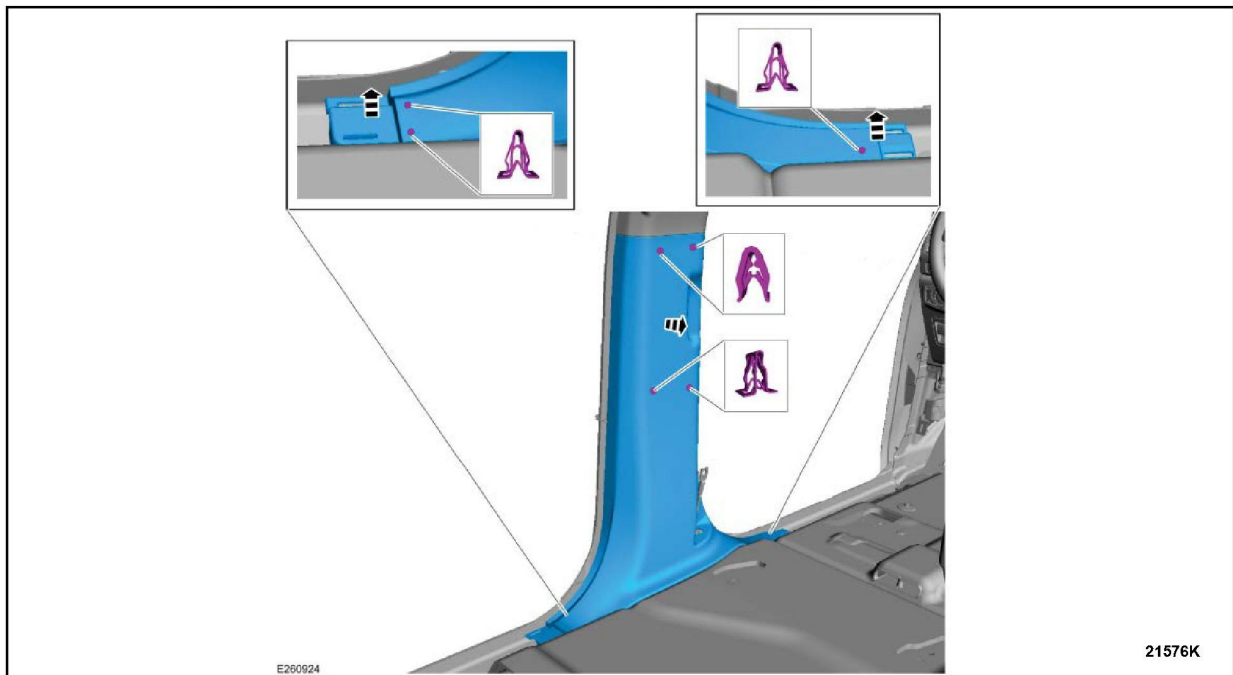

**FIGURE 18**

11. Repeat steps 1 through 10 on the other side of the vehicle.



12. Locate the part label sticker on the back of the Left-Hand (LH) and Right-Hand (RH) front seatbelt retractors. See Figure 19.



21576L

**FIGURE 19**

13. Locate the date code on both the LH and RH front seatbelt retractors. See Figure 20.



21576M

**FIGURE 20**



14. Do either the LH or RH front seatbelt retractor date codes match any of the following date codes listed in the chart below?

**NOTE: The 3rd digit and the 6th digit of the date codes do NOT need to match.**

Yes - Replace the front seatbelt retractor(s) that have the suspect date codes. Follow the WSM procedures in Section 501-20A.

No - Replacement is not needed. Reinstall the lower B-pillar trim panels by reversing steps 1 through 10, then continue to step 15.

01*19*	11*19*	21*19*	34*18*	44*18*
02*19*	12*19*	22*19*	35*18*	45*18*
03*19*	13*19*	23*19*	36*18*	46*18*
04*19*	14*19*	24*19*	37*18*	47*18*
05*19*	15*19*	25*19*	38*18*	48*18*
06*19*	16*19*	26*19*	39*18*	49*18*
07*19*	17*19*	27*19*	40*18*	50*18*
08*19*	18*19*	31*18*	41*18*	51*18*
09*19*	19*19*	32*18*	42*18*	52*18*
10*19*	20*19*	33*18*	43*18*	

15. Check the active restraint system for correct operation. Refer to Diagnosis and Testing in WSM Section 501-20A.

**IMPORTANT NOTE: Federal law prohibits selling motor vehicle parts or components that are under safety, compliance, or emissions recall. Unless a part is requested to be returned to Ford, all parts replaced under this FSA must be scrapped in accordance with all applicable local, state and federal environmental protection and hazardous material regulations. Refer to the Parts Retention, Return, & Scrapping section of the FSA dealer bulletin for further information.**

