



Stacy L. Balzer
Director
Service Engineering Operations
Ford Customer Service Division

Ford Motor Company
PO Box 1904
Dearborn, Michigan 48121

February 12, 2024

TO: All U.S. Ford and Lincoln Dealers

SUBJECT: Advance Notice -- Safety Recall 24S06
Certain 2018-2020 Model Year Ford Expedition and Lincoln Navigator Vehicles
Inadvertent Retractor Pretensioner Deployment

AFFECTED VEHICLES

Vehicle	Model Year	Assembly Plant	Build Dates
Ford Expedition	2018	Kentucky	1-Oct-2018 through 16-Oct-2018
Ford Expedition	2019	Kentucky	1-Oct-2018 through 30-Jun-2019
Ford Expedition	2020	Kentucky	12-Apr-2019 through 27-Apr-2019
Lincoln Navigator	2018	Kentucky	1-Oct-2018 through 15-Oct-2018
Lincoln Navigator	2019	Kentucky	1-Oct-2018 through 28-Jun-2019
Lincoln Navigator	2020	Kentucky	9-Apr-2019 through 27-Apr-2019

US population of affected vehicles: 77,515. Affected vehicles are identified in OASIS and FSA VIN Lists.

REASON FOR THIS SAFETY RECALL

On some of the affected vehicles, the driver and/or front passenger seatbelt retractor pretensioners may deploy inadvertently while the vehicle's engine is on. Inadvertent deployment of the retractor pretensioner will result in the seatbelt being locked in position and will not retract or extend, which is noticeable to the occupant. While the primary seatbelt locking functions continue to function properly, a seatbelt that does not retract or extend may result in injury in the event of a crash.

SERVICE ACTION

DO NOT DEMONSTRATE OR DELIVER any new in-stock vehicles involved in this safety recall. A complete Dealer Bulletin will be provided to dealers later in the second half of 2024, when it is anticipated that parts ordering information and repair instructions will be available to support this safety recall. For new vehicle storage guidelines, refer to EFC13033, Storage Guidelines for New Vehicles.

IMPORTANT: Dealers should open a Repair Order (RO) only when a full dealer bulletin is published. Opening an RO against an Awareness or Advance Notice will result in warranty rejections against a recall.

CUSTOMER NOTIFICATION

Owners of record will be notified via first-class mail after repair instructions and parts ordering information have been provided to dealers.

PLEASE NOTE:

Federal law requires dealers to complete this recall service before a new vehicle is delivered to the buyer or lessee. Violation of this requirement by a dealer could result in a civil penalty of up to \$27,168 per vehicle. Correct all vehicles in your new vehicle inventory prior to delivery.

DEALER-OPERATED RENTAL VEHICLES

The Fixing America's Surface Transportation (FAST) Act law effective June 2016 prohibits a rental company from selling, renting or leasing vehicles subject to a safety or compliance recall. Please consult your legal counsel for legal advice.

QUESTIONS & ASSISTANCE

For questions and assistance, contact the Special Service Support Center (SSSC) via the SSSC Web Contact Site. The SSSC Web Contact Site can be accessed through the Professional Technician System (PTS) website using the SSSC link listed at the bottom of the OASIS VIN report screen or listed under the SSSC tab.

Sincerely,

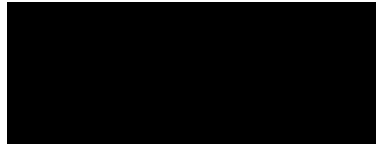

Stacy L. Balzer



Ford Motor Company
Ford Customer Service Division
PO Box 1904
Dearborn, Michigan 48121

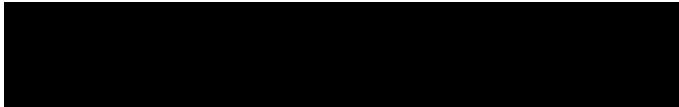

March 2024

JOHN A. SAMPLE
123 SAMPLE ST
SAMPLE CITY, MI 12345-6789

***** IMPORTANT SAFETY RECALL *****

Safety Recall Notice 24S06 / NHTSA Recall 24V099

2019 Expedition

This Notice Applies to Your Vehicle, Vehicle Identification Number (VIN):

This notice is sent to you in accordance with the National Traffic and Motor Vehicle Safety Act.

Ford Motor Company has decided that a defect which relates to motor vehicle safety exists in certain 2018-2020 Ford Expedition vehicles, with the VIN shown above.

We apologize for this situation and want to assure you that, with your assistance, we will correct this condition. Our commitment, together with your dealer, is to provide you with the highest level of service and support.

What is the issue? On some of the affected vehicles, the driver and/or front passenger seatbelt retractor pretensioners may deploy inadvertently while the vehicle's engine is on.

What is the risk? Inadvertent deployment of the retractor pretensioner will result in the seatbelt being locked in position and will not retract or extend, which is noticeable to the occupant. A seatbelt that does not retract or extend may result in injury in the event of a crash.

What will Ford and your dealer do? Ford Motor Company is working closely with its suppliers to produce parts for this repair. When parts become available, Ford Motor Company will notify you via mail to schedule a service appointment with your dealer for repairs to be completed free of charge (parts and labor). Parts are anticipated to be available in the second half of 2024.

What should you do? When parts are available, Ford Motor Company will send a letter to inform you that parts are available and to contact your dealer to schedule a repair. Ford has not issued instructions to stop driving your vehicle under this safety recall. When parts are available, you should contact your dealer for an appointment to have your vehicle remedied as soon as practicable. If you currently have an illuminated airbag warning lamp on your vehicle, please take it in to your dealer for a diagnosis.



Airbag Warning Indicator

If you do not already have a servicing dealer, you can access or dealer addresses, maps, and driving instructions.

If you are still having difficulty getting your vehicle repaired in a reasonable time or without charge, you may write the Administrator, National Highway Traffic Safety Administration, 1200 New Jersey Ave. S.E., Washington, D.C. 20590 or call the toll-free Vehicle Safety Hotline at 1-888-327-4236 (TTY: 1-800-424-9153) or go to [NHTSA.gov](https://www.nhtsa.gov). Reference NHTSA Safety Recall **24V099**.

Please note: Federal law requires that any vehicle lessor receiving this recall notice must forward a copy of this notice to the lessee within ten days.

Thank you for your attention to this important matter.

Ford Customer Service Division



Ford Motor Company
Ford, División de Servicio al Cliente
PO Box 1904
Dearborn, Michigan 48121

Marzo de 2024

JOHN A. SAMPLE
123 SAMPLE ST
SAMPLE CITY, MI 12345-6789

***** CAMPAÑA DE SEGURIDAD IMPORTANTE *****

Aviso de campaña 24S06 / Campaña 24V099 DE LA NHTSA

2019 Expedition

Este aviso se aplica al vehículo, número de identificación del vehículo (VIN): [REDACTED]

Este aviso se le envía de acuerdo con la Ley Nacional de Seguridad de Tránsito y Vehículos Motorizados de los EE. UU.

Ford Motor Company determinó que existe un defecto relacionado con la seguridad en algunos vehículos Ford Expedition 2018-2020, con el VIN que aparece más arriba.

Lamentamos esta situación y deseamos asegurarle que, con su ayuda, corregiremos el problema. Nuestro compromiso, junto con el de su distribuidor, es ofrecerle servicio y apoyo de alto nivel.

¿Cuál es el problema?

En algunos de los vehículos afectados, los pretensores del retractor del cinturón de seguridad del conductor y/o del pasajero delantero pueden desplegarse inadvertidamente mientras el motor del vehículo está encendido.

¿Qué riesgo existe?

El despliegue inadvertido del pretensor del retractor provocará que el cinturón de seguridad quede bloqueado en su posición y no se retraiga ni se extienda, lo cual es perceptible para el ocupante. Un cinturón de seguridad que no se retrae ni se extiende puede provocar lesiones en caso de choque.

¿Qué medidas adoptarán Ford y su distribuidor?

Ford Motor Company colabora estrechamente con sus proveedores para fabricar las piezas para esta reparación. Cuando estas estén disponibles, Ford Motor Company le avisará mediante correo para programar una cita de servicio con su distribuidor y así realizar las reparaciones sin costo alguno (piezas y mano de obra). Se prevé que las piezas estarán disponibles en el segundo semestre de 2024.

¿Qué debe hacer?

Cuando las piezas estén disponibles, Ford Motor Company le enviará una carta para informarle la disponibilidad de estas y solicitarle que se comunique con su distribuidor a fin de programar la reparación.



Airbag Warning Indicator

Para esta campaña de seguridad, Ford no ha emitido instrucciones de dejar manejar el vehículo. Cuando las piezas se encuentren disponibles, deberá ponerse en contacto con su distribuidor a fin de programar una cita para solucionar este problema lo más pronto posible.

Si, actualmente, hay una luz de advertencia de la bolsa de aire encendida en su vehículo, llévelo a su concesionario para un diagnóstico.

Si aún no tiene un concesionario para realizar el servicio, puede acceder a [REDACTED] para conocer las direcciones de los concesionario, ver mapas y obtener las instrucciones para llegar.

Si continúa con dificultades para reparar su vehículo en un tiempo razonable o sin cargo, le sugerimos que escriba al Administrador, National Highway Traffic Safety Administration, 1200 New Jersey Ave. S.E., Washington, D.C. 20590 o bien que llame sin cargo a la línea directa de seguridad vehicular al 1-888-327-4236 (TTY: 1-800-424-9153) o visite [NHTSA.gov](https://www.nhtsa.gov). Mencione la Campaña de seguridad **24V099 de la NHTSA**.

Tenga presente que: La ley federal exige que los arrendadores de vehículos que reciban este aviso de campaña envíen una copia del mismo al arrendatario en un plazo de diez días.

Gracias por su atención en este asunto sumamente importante.

Ford, División de Servicio al Cliente



L I N C O L N

Lincoln
PO Box 1904
Dearborn, Michigan 48121



March 2024

JOHN A. SAMPLE
123 SAMPLE ST
SAMPLE CITY, MI 12345-6789

***** IMPORTANT SAFETY RECALL *****

Safety Recall Notice 24S06 / NHTSA Recall 24V099

2019 Navigator

This Notice Applies to Your Vehicle, Vehicle Identification Number (VIN):

This notice is sent to you in accordance with the National Traffic and Motor Vehicle Safety Act.

Lincoln has decided that a defect which relates to motor vehicle safety exists in certain 2018-2020 Lincoln Navigator vehicles, with the VIN shown above.

We apologize for this situation and want to assure you, with your assistance, we will correct this condition. Our commitment, together with your retailer, is to provide you with the highest level of service and support.

What is the issue? On some of the affected vehicles, the driver and/or front passenger seatbelt retractor pretensioners may deploy inadvertently while the vehicle's engine is on.

What is the risk? Inadvertent deployment of the retractor pretensioner will result in the seatbelt being locked in position and will not retract or extend, which is noticeable to the occupant. A seatbelt that does not retract or extend may result in injury in the event of a crash.

What will Lincoln and your retailer do? Lincoln is working closely with its suppliers to produce parts for this repair. When parts become available, Lincoln will notify you via mail to schedule a service appointment with your retailer for repairs to be completed free of charge (parts and labor). Parts are anticipated to be available in the second half of 2024.

What should you do? When parts are available, Lincoln will send a letter to inform you that parts are available and to contact your retailer to schedule a repair.

Lincoln has not issued instructions to stop driving your vehicle under this safety recall. When parts are available, you should contact your retailer for an appointment to have your vehicle remedied as soon as practicable.

If you currently have an illuminated airbag warning lamp on your vehicle, please take it in to your dealer for a diagnosis.

If you do not already have a servicing retailer, you can access for retailer addresses, maps, and driving instructions.



Airbag Warning Indicator

If you are still having difficulty getting your vehicle repaired in a reasonable time or without charge, you may write the Administrator, National Highway Traffic Safety Administration, 1200 New Jersey Ave. S.E., Washington, D.C. 20590 or call the toll-free Vehicle Safety Hotline at 1-888-327-4236 (TTY: 1-800-424-9153) or go to [NHTSA.gov](https://www.nhtsa.gov). Reference NHTSA Safety Recall **24V099**.

Please note: Federal law requires that any vehicle lessor receiving this recall notice must forward a copy of this notice to the lessee within ten days.

Thank you for your attention to this important matter.

Lincoln



L I N C O L N

Lincoln
PO Box 1904
Dearborn, Michigan 48121

Marzo de 2024

JOHN A. SAMPLE
123 SAMPLE ST
SAMPLE CITY, MI 12345-6789

***** CAMPAÑA DE SEGURIDAD IMPORTANTE *****

Aviso de campaña 24S06 / Campaña 24V099 DE LA NHTSA

2019 Navigator

Este aviso se aplica al vehículo, número de identificación del vehículo (VIN): [REDACTED]

Este aviso se le envía de acuerdo con la Ley Nacional de Seguridad de Tránsito y Vehículos Motorizados de los EE. UU.

Lincoln determinó que existe un defecto relacionado con la seguridad del vehículo motorizado en ciertos vehículos Lincoln Navigator 2018-2020 con el VIN que aparece más arriba.

Lamentamos esta situación y deseamos asegurarle que, con su ayuda, corregiremos el problema. Nuestro compromiso, junto con el de su distribuidor, es ofrecerle servicio y apoyo de alto nivel.

¿Cuál es el problema? En algunos de los vehículos afectados, los pretensores del retractor del cinturón de seguridad del conductor y/o del pasajero delantero pueden desplegarse inadvertidamente mientras el motor del vehículo está encendido.

¿Qué riesgo existe? El despliegue inadvertido del pretensor del retractor provocará que el cinturón de seguridad quede bloqueado en su posición y no se retraiga ni se extienda, lo cual es perceptible para el ocupante. Un cinturón de seguridad que no se retrae ni se extiende puede provocar lesiones en caso de choque.

¿Qué harán Lincoln y su distribuidor? Lincoln colabora estrechamente con sus proveedores para fabricar las piezas para esta reparación. Cuando estas estén disponibles, Lincoln le avisará mediante correo para programar una cita de servicio con su minorista y así realizar las reparaciones sin costo alguno (piezas y mano de obra). Se prevé que las piezas estarán disponibles en el segundo semestre de 2024.

¿Qué debe hacer? Cuando las piezas estén disponibles, Lincoln le enviará una carta para informarle la disponibilidad de estas y solicitarle que se comunique con su minorista a fin de programar la reparación.



Airbag Warning Indicator

Lincoln no emitió instrucciones de dejar de manejar el vehículo para esta campaña de seguridad. Cuando las piezas se encuentren disponibles, deberá ponerse en contacto con su minorista a fin de programar una cita para solucionar este problema lo más pronto posible.

Si, actualmente, hay una luz de advertencia de la bolsa de aire encendida en su vehículo, llévelo a su concesionario para un diagnóstico.

Si aún no tiene un minorista para realizar el servicio, puede acceder a [REDACTED] para conocer las direcciones de los minoristas, ver mapas y obtener las instrucciones para llegar.

Si continúa con dificultades para reparar su vehículo en un tiempo razonable o sin cargo, le sugerimos que escriba al Administrador, National Highway Traffic Safety Administration, 1200 New Jersey Ave. S.E., Washington, D.C. 20590 o bien que llame sin cargo a la línea directa de seguridad vehicular al 1-888-327-4236 (TTY: 1-800-424-9153) o visite [NHTSA.gov](https://www.nhtsa.gov). Mencione la Campaña de seguridad **24V099 de la NHTSA**.

Tenga presente que: La ley federal exige que los arrendadores de vehículos que reciban este aviso de campaña envíen una copia del mismo al arrendatario en un plazo de diez días.

Gracias por su atención en este asunto sumamente importante.

Lincoln



Stacy L. Balzer
 Director
 Service Engineering Operations
 Ford Customer Service Division

Ford Motor Company
 PO Box 1904
 Dearborn, Michigan 48121

June 20, 2024

TO: All U.S. Ford and Lincoln Dealers

**SUBJECT: NEW VEHICLE DEMONSTRATION / DELIVERY HOLD
 Safety Recall 24S06**

Certain 2018-2020 Model Year Ford Expedition and Lincoln Navigator Vehicles
 Front Seatbelt Retractor Date Code Inspection

REF: Advance Notice -- Safety Recall 24S06
 Dated: February 12, 2024

AFFECTED VEHICLES

Vehicle	Model Year	Assembly Plant	Build Dates
Ford Expedition	2018	Kentucky	October 1, 2018 through October 16, 2018
Ford Expedition	2019	Kentucky	October 1, 2018 through June 30, 2019
Ford Expedition	2020	Kentucky	April 12, 2019 through April 27, 2019
Lincoln Navigator	2018	Kentucky	October 1, 2018 through October 15, 2018
Lincoln Navigator	2019	Kentucky	October 1, 2018 through June 28, 2019
Lincoln Navigator	2020	Kentucky	April 9, 2019 through April 27, 2019

US population of affected vehicles: 77,544. Affected vehicles are identified in OASIS and FSA VIN Lists.

REASON FOR THIS SAFETY RECALL

On some of the affected vehicles, the driver and/or front passenger seatbelt retractor pretensioners may deploy inadvertently while the vehicle's engine is on. Inadvertent deployment of the retractor pretensioner will result in the seatbelt being locked in position and will not retract or extend, which is noticeable to the occupant. While the primary seatbelt locking functions continue to function properly, a seatbelt that does not retract or extend may result in injury in the event of a crash.

SERVICE ACTION

DO NOT DEMONSTRATE OR DELIVER any new in-stock vehicles involved in this safety recall. Before demonstrating or delivering any new in-stock vehicles involved in this recall, dealers are to first inspect each vehicle to determine if the vehicle seat belt retractor part numbers are on the replacement list, then replace those retractors that are involved. This service must be performed on all affected vehicles at no charge to the vehicle owner. For new vehicle storage guidelines, refer to EFC13033, Storage Guidelines for New Vehicles.

To assist vehicle owners to have this repair completed when parts are available, dealers should:

- Arrange to pick up the owner's vehicle and drive it to the dealership for repairs and re-deliver the owner's vehicle after repairs have been completed.
- Pick-Up & Delivery should be made available for all customers.

OWNER NOTIFICATION MAILING SCHEDULE

Owner letters are expected to be mailed the week of July 1, 2024. Dealers should repair any affected vehicles that arrive at their dealerships, whether or not the customer has received a letter.

PLEASE NOTE:

Federal law requires dealers to complete this recall service before a new vehicle is delivered to the buyer or lessee. Violation of this requirement by a dealer could result in a civil penalty of up to \$27,168 per vehicle. Correct all vehicles in your new vehicle inventory before delivery.

ATTACHMENTS

- Administrative Information
- Labor Allowances and Parts Ordering Information
- Technical Instructions
- Mobile Service Repair Assessment
- Vehicle Pick-Up & Delivery Record
- Owner Notification Letters
- Recall Reimbursement Plan

QUESTIONS & ASSISTANCE

For questions and assistance, contact the Special Service Support Center (SSSC) via the SSSC Web Contact Site. The SSSC Web Contact Site can be accessed through the Professional Technician System (PTS) website using the SSSC link listed at the bottom of the OASIS VIN report screen or listed under the SSSC tab.

Sincerely,

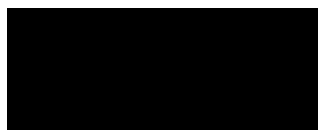

Stacy L. Balzer

Safety Recall 24S06

MOBILE SERVICE REPAIR ASSESSMENT LEVEL

All repairs in this program have the following assessment level.

Ⓢ - Not a Mobile Service Repair

OASIS ACTIVATION

OASIS was activated on February 12, 2024.

FSA VIN LISTS ACTIVATION

FSA VIN Lists were available through [REDACTED] February 12, 2024. Owner names and addresses will be available by July 26, 2024.

NOTE: Your FSA VIN Lists may contain owner names and addresses obtained from motor vehicle registration records. The use of such motor vehicle registration data for any purpose other than in connection with this recall is a violation of law in several states, provinces, and countries. Accordingly, you must limit the use of this listing to the follow-up necessary to complete this recall.

SOLD VEHICLES

- Ford has not issued instructions to stop selling/delivering or driving used vehicles under this safety recall. Owners should contact their dealers for an appointment to have their vehicles remedied as soon as practicable.
- Immediately contact any of your affected customers whose vehicles are not on your VIN list but are identified in OASIS. Give the customer a copy of the Owner Notification Letter (when available) and schedule a service date.
- Correct other affected vehicles identified in OASIS which are brought to your dealership.
- Dealers are to prioritize repairs of customer vehicles over repairs of new and used vehicle inventory.

STOCK VEHICLES

- Correct all affected units in your new vehicle inventory before delivery.
- Use OASIS to identify any affected vehicles in your used vehicle inventory.

DEALER-OPERATED RENTAL VEHICLES

The Fixing America's Surface Transportation (FAST) Act law effective June 2016 prohibits a rental company from selling, renting, or leasing vehicles subject to a safety or compliance recall. Please consult your legal counsel for legal advice.

BRANDED / SALVAGED TITLE VEHICLES

Affected branded / salvaged title vehicles are eligible for this recall.

Safety Recall 24S06**OWNER REFUNDS**

- **This safety recall must still be performed, even if the owner has paid for a previous repair. Claiming a refund will not close the recall on the vehicle.**
- Ford Motor Company is offering a refund for owner-paid repairs covered by this recall if the repair was performed before the date indicated in the reimbursement plan, which is posted with this bulletin. Owners are directed to seek reimbursement through authorized dealers or, at their option, directly through Ford Motor Company at PO Box 6251, Dearborn, MI 48121-6251.
- Dealers are also pre-approved to refund owner-paid emergency repairs that were performed away from an authorized servicing dealer after the end date specified in the reimbursement plan. Non-covered repairs, or those judged by Ford to be excessive, will not be reimbursed.
- Refunds will only be provided for the cost associated with the front pretensioner inspection and/or replacement.

PICK-UP & DELIVERY- Participating Dealers

Dealers participating in the Remote Experience Program:

- Ford Dealers - Refer to EFC14125, 2024 Remote Experience Program, Pick-Up & Delivery Offset section for additional details.

PICK-UP & DELIVERY- Non-participating Dealers

Ford Dealers not participating in the 2024 Remote Experience Program for Pick-Up & Delivery are authorized to claim unique services for completing this program.

- Dealers are authorized to claim one-half labor hour per repair for vehicle Pick-Up & Delivery services. Refer to Labor Allowances for details.
- Dealers must retain a Vehicle Pick-Up & Delivery Record with the repair order documentation.

LINCOLN PICK-UP & DELIVERY

Owners of Lincoln vehicles within a 4 year / 50,000-mile warranty have the option of requesting Pick-Up & Delivery service with a Lincoln loaner (up to 2 days), from their dealership. For details, reference EFC14054, 2024 Lincoln Pick-Up & Delivery Updates.

- For Lincoln vehicles outside of 4 years / 50,000-mile warranty, see labor claiming table below.

ADDITIONAL REPAIR (LABOR TIME AND/OR PARTS)

Additional repairs identified as necessary to complete the FSA should be managed as follows:

- For related damage and access time requirements, refer to the Warranty and Policy Manual / Section 6 – Ford & Lincoln Program Policies / General Information & Special Circumstances for FSAs / Related Damage.
- For vehicles within new vehicle bumper-to-bumper warranty coverage, no SSSC approval is required, although related damage must be on a separate repair line with the “Related Damage” radio button checked.
 - Ford vehicles – 3 years or 36,000 miles
 - Lincoln vehicles – 4 years or 50,000 miles
- For vehicles outside new vehicle bumper-to-bumper warranty coverage, submit an Approval Request to the SSSC Web Contact Site before completing the repair.

Safety Recall 24S06

LABOR ALLOWANCES

Description	Labor Operation	Labor Time
Claim 24S06A with the appropriate labor code(s) below		
INSPECT for evaporator drain elbow presence and the date code on both seat belt retractors.	24S06A	0.6 Hours
Extra time to install evaporator drain elbow (Can be claimed with A and C or D)	24S06B	0.6 Hours
Extra time to replace ONE belt retractor (Can be claimed with A and B)	24S06C	0.4 Hours
Extra time to replace BOTH seat belt retractors (Can be claimed with A and B)	24S06D	0.7 Hours
Lincoln vehicle PDL Allowance: <u>Only</u> vehicles <u>outside</u> of Lincoln PDL contract coverage of 4 years/50,000 miles . NOTE: This allowance is for dealer-performed vehicle PDL for dealership repairs only. Can only be claimed once, regardless of outstanding FSAs repaired.	24S06LL	0.5 Hours
Vehicle Pick-Up & Delivery Allowance: This allowance is only for <u>non-eligible</u> 2024 Remote Experience Program Dealers. NOTE: This allowance is for dealer-performed vehicle Pick-Up & Delivery for dealership repairs only. Can only be claimed once, regardless of outstanding FSAs repaired.	24S06PP	0.5 Hours

PARTS REQUIREMENTS / ORDERING INFORMATION

Service Part Number	Claim Quantity	Package Order Quantity	Number in Package	Description
Base part # - 78611B09**	1 as required	1	1	LH Seat Belt Retractor **Interior Color Dependent
Base part # 78611B08**	1 as required	1	1	RH Seat Belt Retractor **Interior Color Dependent
4M2Z-6A614-AA	1 as required	1	1	Evaporator Drain Elbow
Nashua® 324A or 3M™ 3340 Foil Tape	Claim as Misc Expense: OTHER 1 Roll will service many vehicles			Obtain locally if the Evaporator Drain Elbow must be installed

Order your parts through normal order processing channels. To guarantee the shortest delivery time, an emergency order for parts must be placed.

Safety Recall 24S06

DEALER PRICE

For the latest prices, refer to DOES II.

PARTS RETENTION, RETURN, & SCRAPPING

Follow the provisions of the Warranty and Policy Manual, Section 1 - WARRANTY PARTS RETENTION AND RETURN POLICIES. If a replaced part receives a scrap disposition, the part must be scrapped by all applicable local, state, and federal environmental protection and hazardous material regulations. Federal law prohibits selling motor vehicle parts or components that are under safety, compliance, or emissions recall.

EXCESS STOCK RETURN

The excess stock returned for credit must have been purchased from Ford Customer Service Division by Policy Procedure Bulletin 4000.

REPLACED FSA PARTS INSPECTION AND SIGN OFF

Effective March 1st, 2021, all parts replaced as part of an FSA repair with a repair order open date of March 1st, 2021, or later must be inspected and signed off on the repair order by a member of your dealer fixed operations management team or an employee of the task has been delegated to. If the task is to be delegated to a non-management employee, the employee needs to be someone other than the technician who completed the repair and needs to understand the importance of completing this task consistently and accurately.

- All parts replaced as part of an FSA repair should be returned to the parts department following the Warranty Parts Retention and Return Policies.
- Inspect the replaced parts to verify the FSA repair was completed.
- If the FSA repair is found to be complete, the designated employee signs the repair order line or parts return stamp area (electronic or hand signed) for the FSA repair indicating the parts were inspected and validated to have been replaced.
- After the parts have been inspected, they should be handled based on the guidance in the parts status report in the Online Warranty System (Hold, Return, CORE, Scrap, etc.). Please visit FMCDEALER > PARTS & SERVICE > WARRANTY ADMINISTRATION & WARRANTY PARTS RETURN for the latest [REDACTED]
- This process is subject to review during warranty audits for FSA repairs with a repair order open date of March 1st, 2021, or later. Any eligible FSA claims requiring parts replacement found not to have been inspected and signed off during a warranty audit will be subject to chargeback and consideration for enrollment into the Dealer Incomplete Recall Repair Process.

Note: Other approvals (electronic or handwritten) for add-on repair lines, dealer-owned vehicle repairs, and repeat repairs do not qualify as FSA parts inspection approvals. The post-repair FSA parts inspection process (electronic or handwritten) is independent of other warranty approval requirements. The approval by the designated employee implies that the FSA parts were found to be replaced and must be able to be identified on the Repair Order. If multiple FSAs require approval on a single Repair Order, each applicable occurrence will require individual post-repair approval by the designated employee.

CERTAIN 2018-2020 MODEL YEAR EXPEDITION AND NAVIGATOR VEHICLES — FRONT SEATBELT RETRACTOR DATE CODE INSPECTION

SERVICE PROCEDURE

IMPORTANT! The Service Technician Specialty Training (STST) Competency 10 certification requirement, for U.S. market only, will be enforced starting with repair orders opened on or after April 1, 2024. Field Service Action (FSA) repairs will reject if the repairing technician is not certified in STST Competency 10 FSA. See Electronic Field Communication (EFC) 14251 for more details.

Evaporator Drain Tube Inspection

WARNING: The vehicle should be cool enough to touch before performing this procedure.

1. Using an extension mirror through the Right Hand (RH) side of the engine compartment, inspect the evaporator drain tube for the presence of an elbow installed.

- Is there an elbow installed? See Figure 1 for correct location to inspect and Figure 2 for an example of the elbow installed.

Yes - Passes inspection. Proceed to Front Seatbelt Retractor Inspection procedure, on Page 6.

No - Does not pass inspection. Proceed to Step 2.

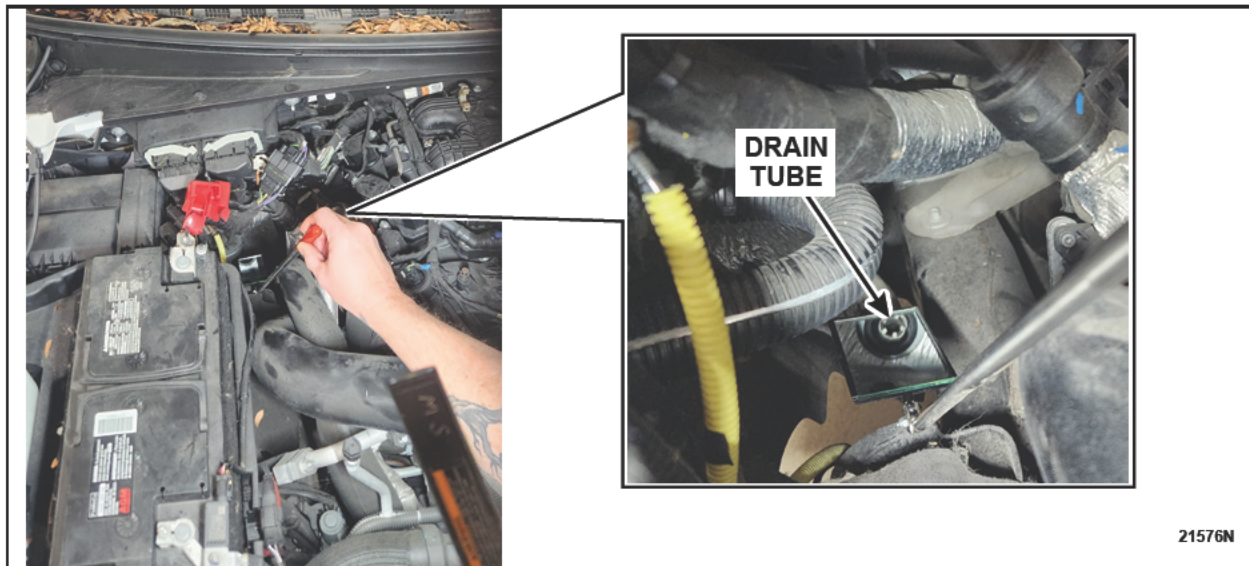

FIGURE 1



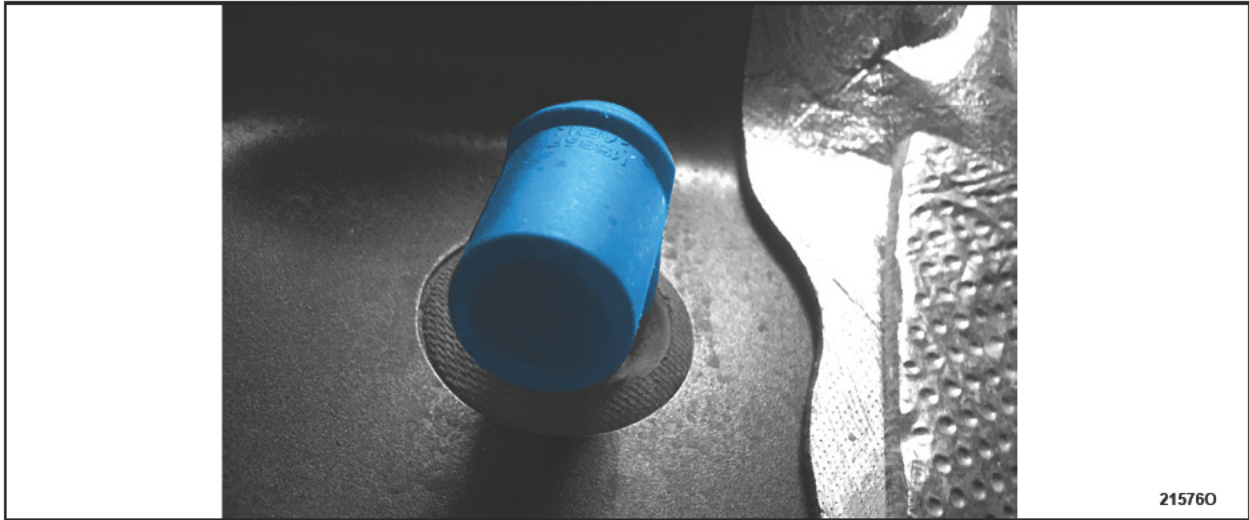

FIGURE 2

2. Raise the vehicle and remove the RH front tire.
3. Remove the RH front fender splash shield. Follow the Workshop Manual (WSM) procedures in Section 501-02.
4. Using needle nose pliers or equivalent, remove and discard the metal shield from the evaporator drain tube by bending the tabs away from the tube. See Figures 3 through 5.

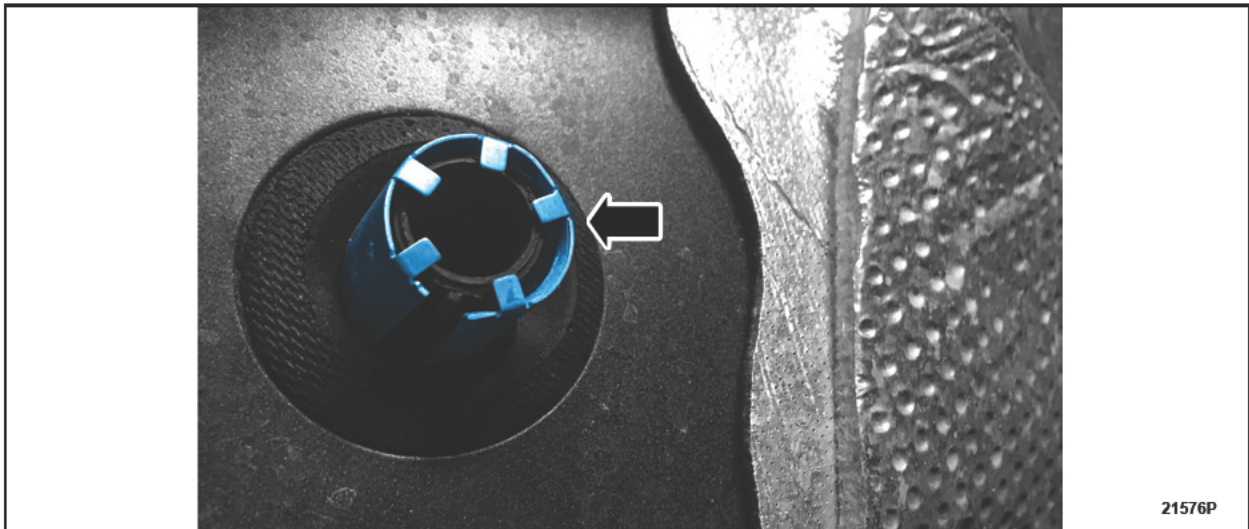

FIGURE 3



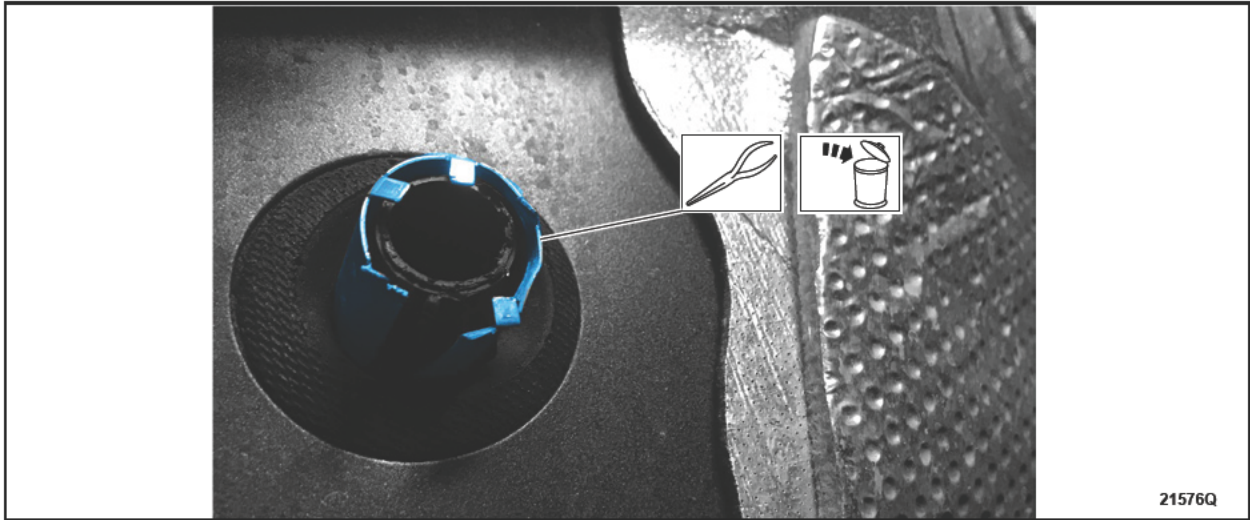

FIGURE 4



FIGURE 5



5. Lubricate the inside of the elbow with water. Install the short end of the elbow onto the drain tube. See Figures 6 and 7.

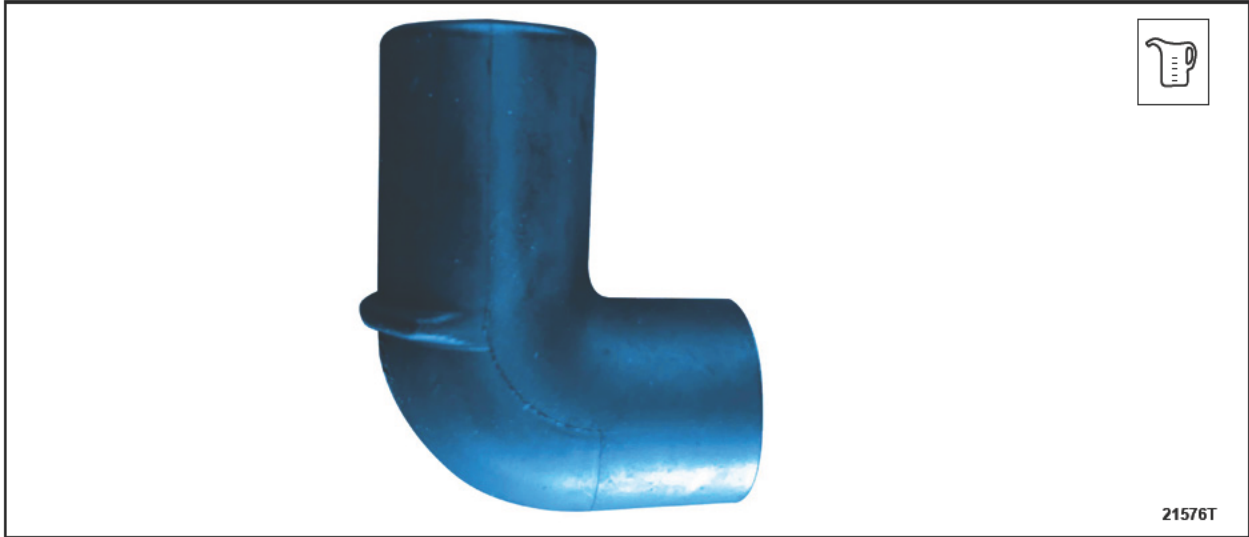

FIGURE 6

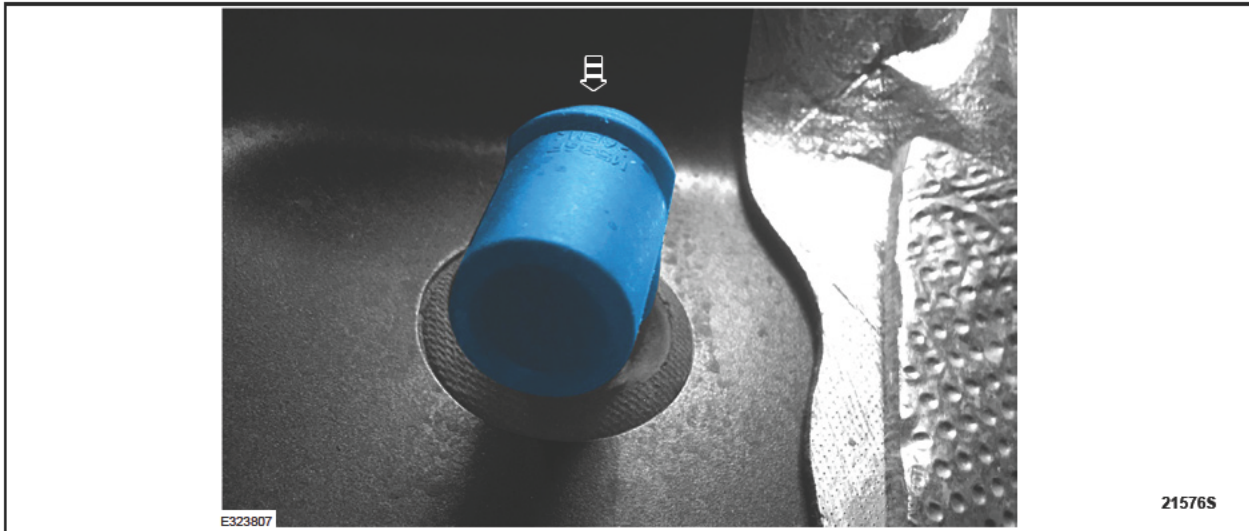

FIGURE 7



6. Clean the surface of the elbow, drain seal, and surrounding sheet metal with isopropyl alcohol or equivalent.

7. Apply heat shield tape over the elbow. See Figure 8.

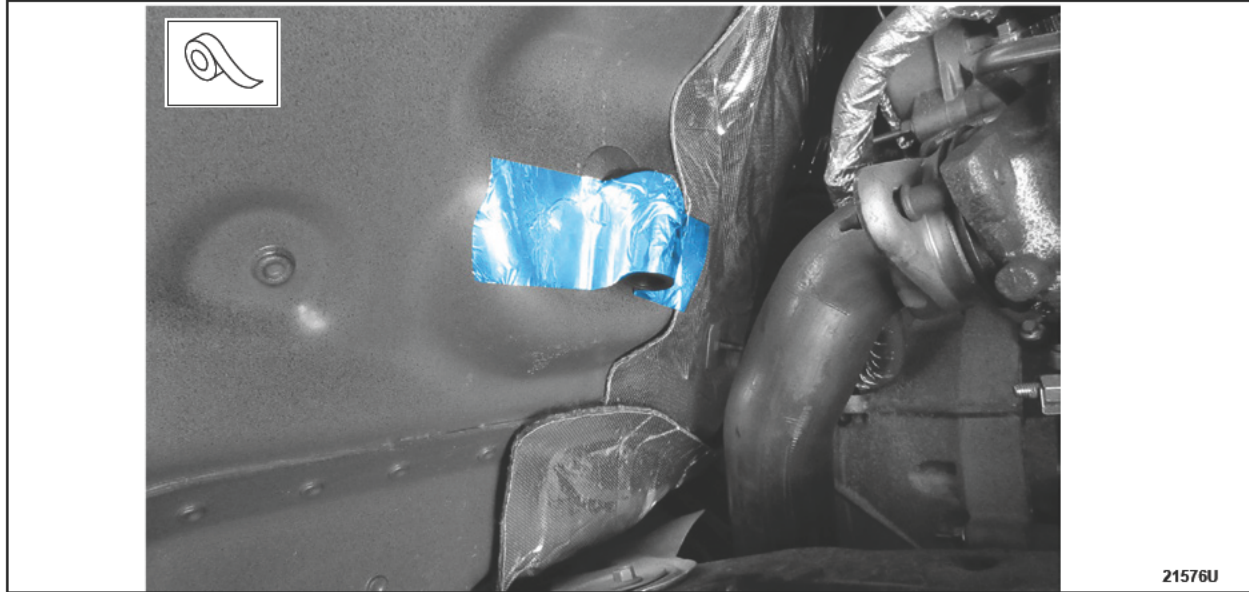

FIGURE 8

8. Reassemble the vehicle by reversing Steps 2 and 3, then proceed to Front Seatbelt Retractor Inspection procedure, on Page 6.

NOTE: Make sure to inspect the carpet for dampness and/or odor and service as necessary.



Front Seatbelt Retractor Inspection

1. Position the front door weatherstrip aside. See Figure 9.

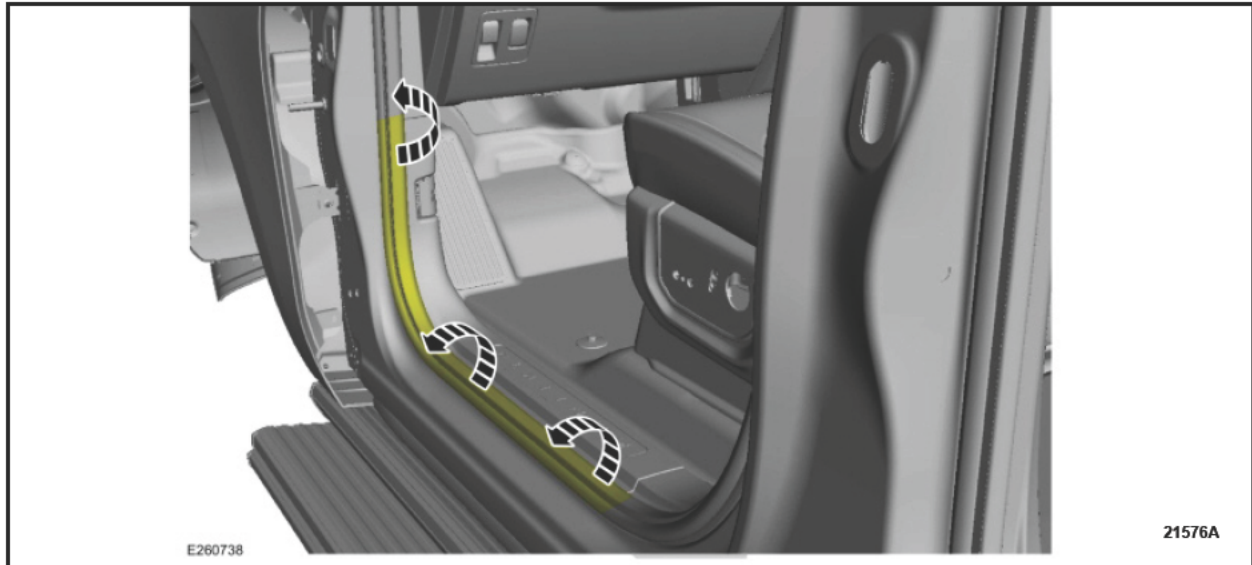

FIGURE 9

2. Release the clips and remove the front door scuff plate trim panel. See Figure 10.

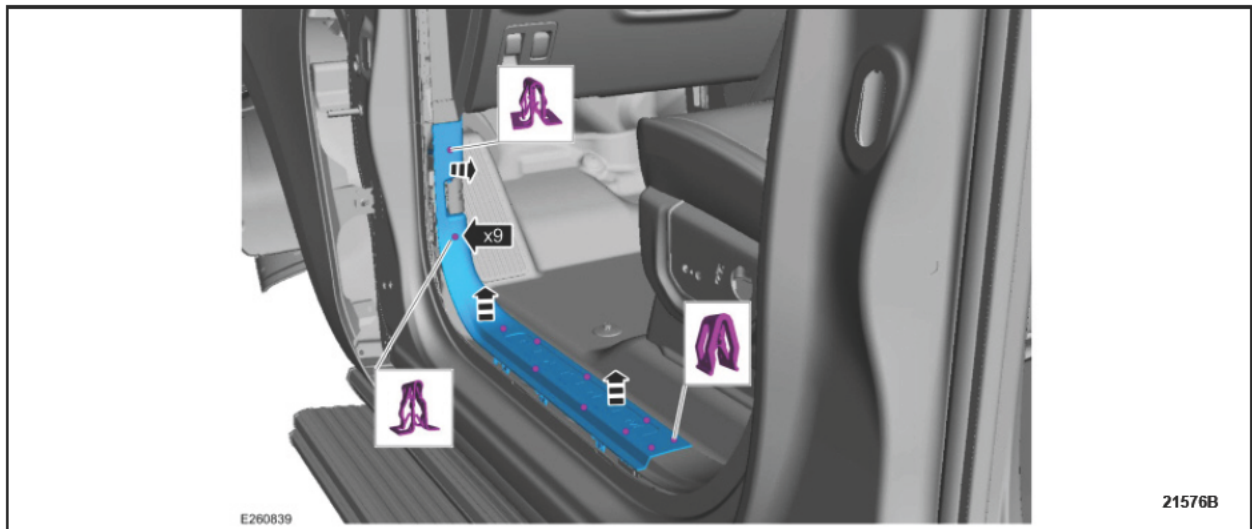

FIGURE 10



3. Position the rear door weatherstrip aside. See Figure 11.

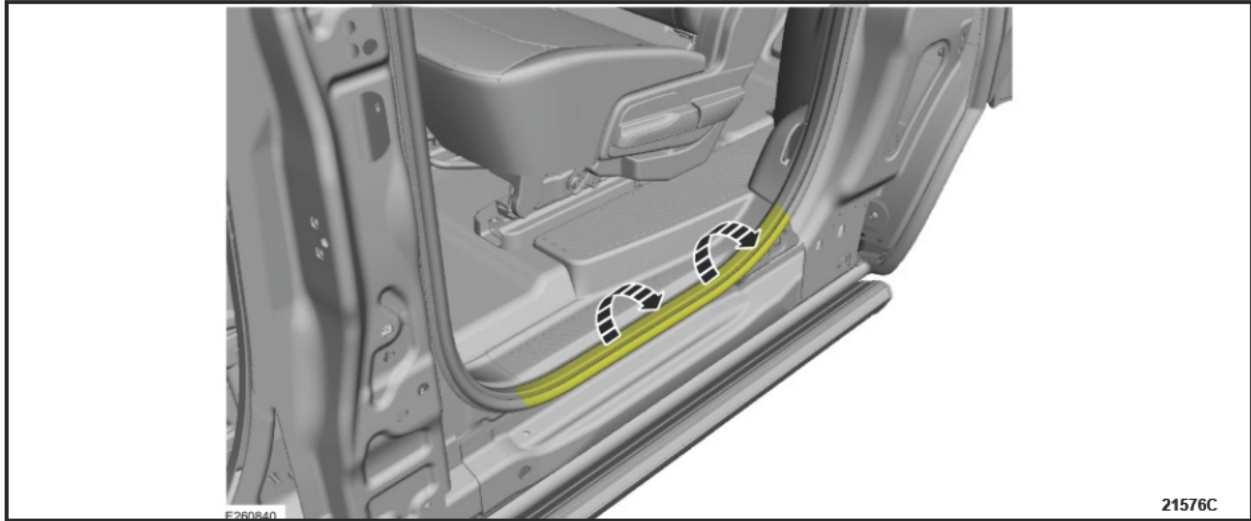

FIGURE 11

4. Position the second row seat forward. See Figure 12.

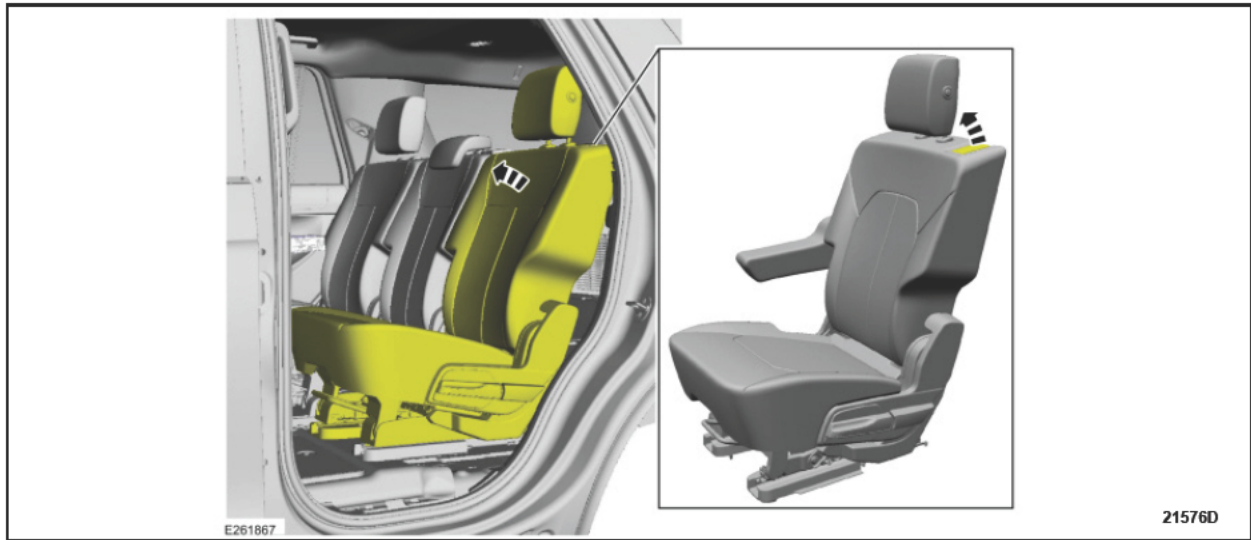

FIGURE 12



5. Release the clips and remove the rear door scuff plate trim panel. See Figure 13.

NOTE: Long wheelbase shown, short wheelbase similar.

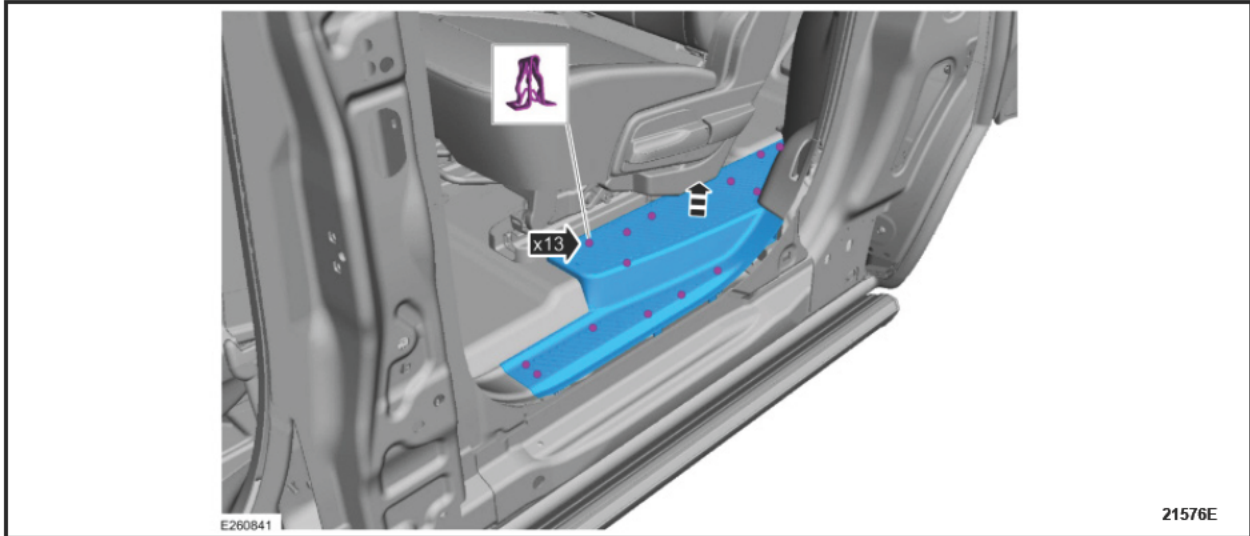

FIGURE 13

6. Position the front door weatherstrip aside. See Figure 14.

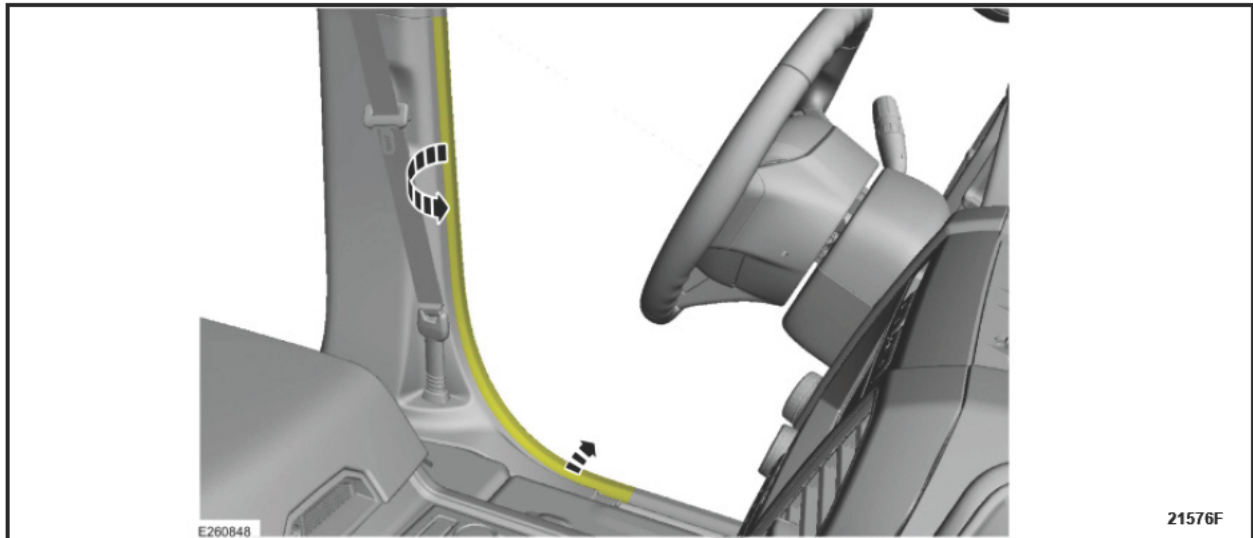

FIGURE 14



7. Position the rear door weatherstrip aside. See Figure 15.

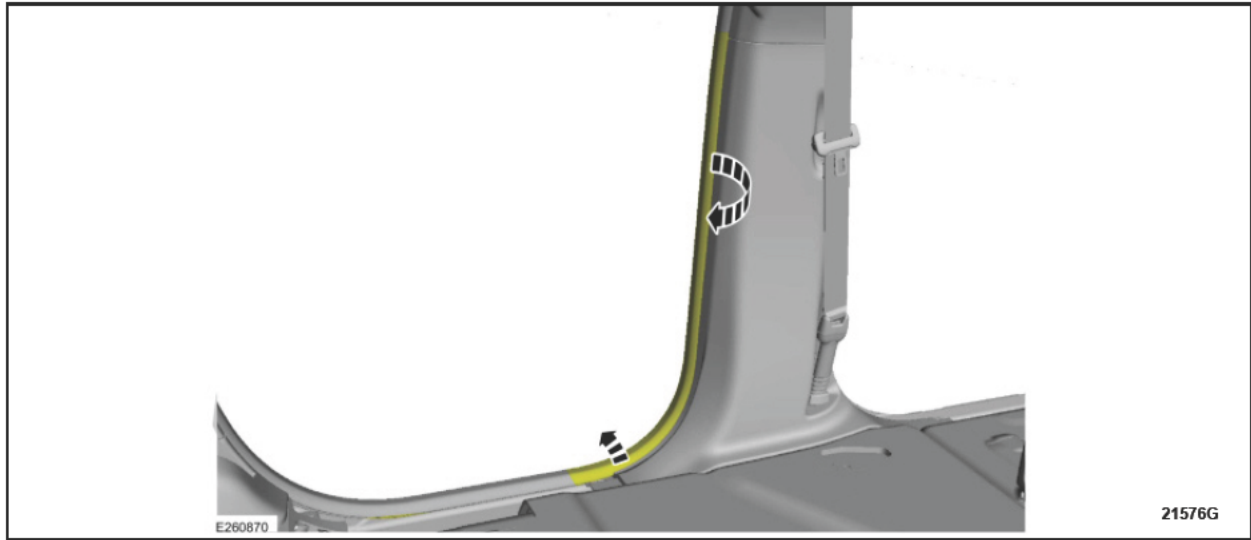

FIGURE 15

8. Press in on the release button and disconnect the front seatbelt retractor from the front seatbelt anchor pretensioner. See Figure 16.

- Use the General Equipment: Flat-Bladed Screwdriver

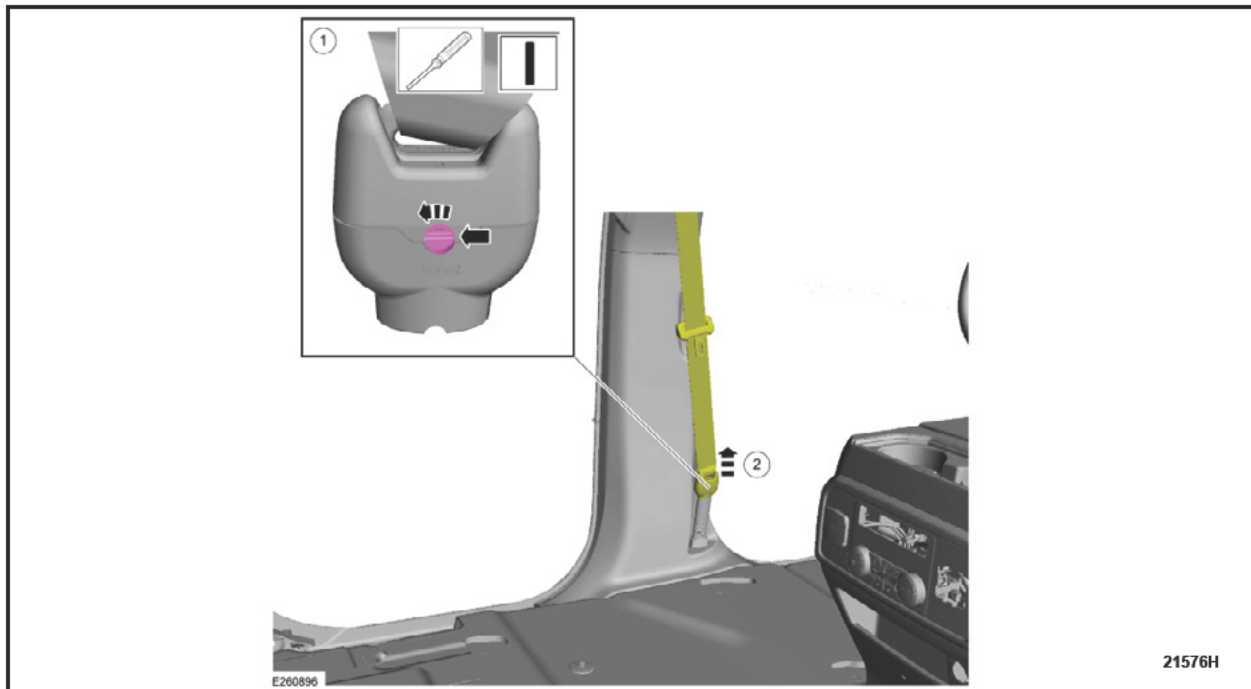

FIGURE 16



9. Press in on the sides of the front seatbelt anchor pretensioner boot, then lift up and remove the front seatbelt anchor pretensioner boot. See Figure 17.

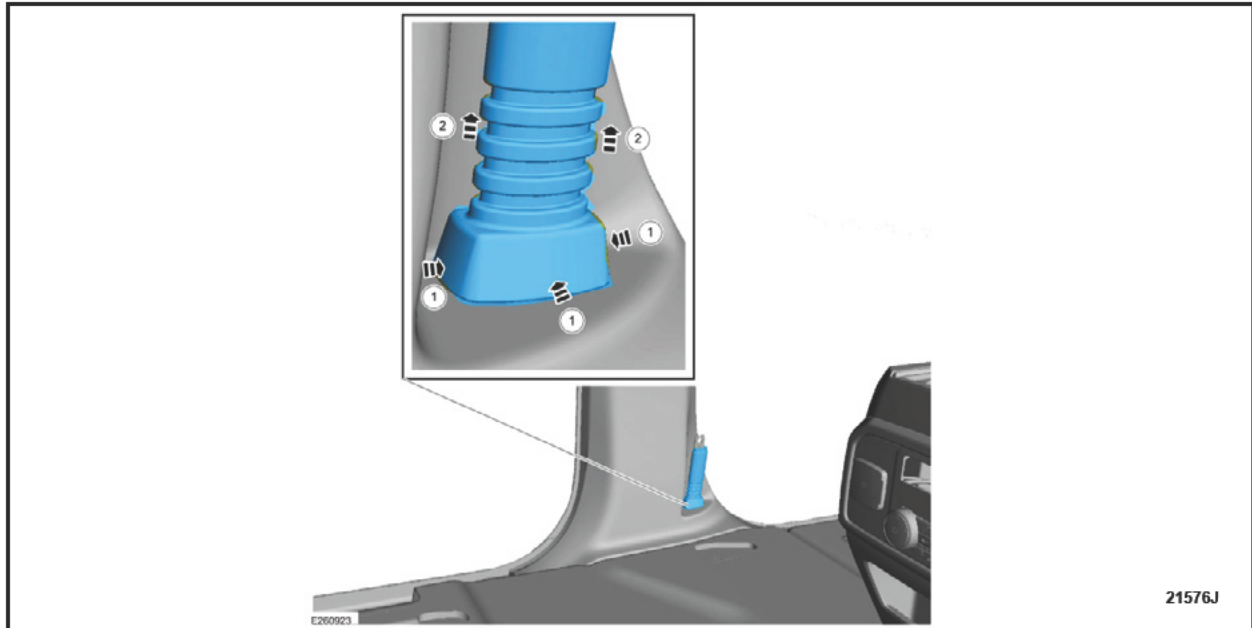

FIGURE 17

10. Release the clips and remove the lower B-pillar trim panel. See Figure 18.

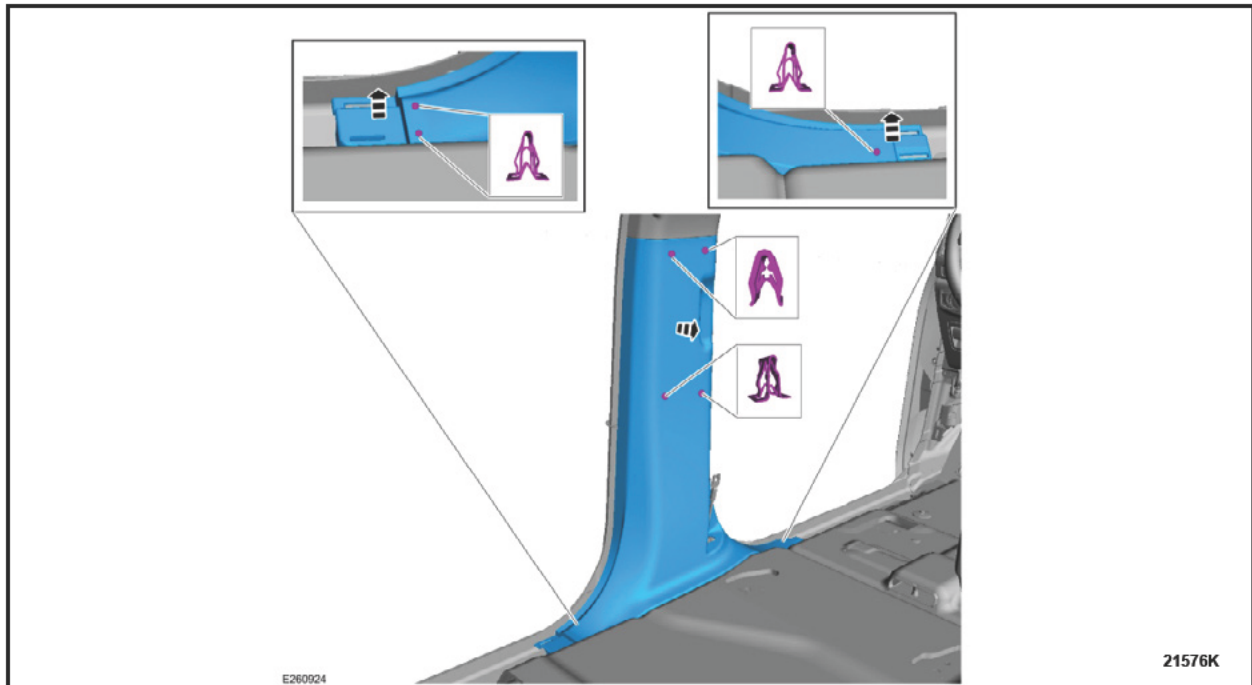

FIGURE 18

11. Repeat steps 1 through 10 on the other side of the vehicle.



12. Locate the part label sticker on the back of the Left-Hand (LH) and Right-Hand (RH) front seatbelt retractors. See Figure 19.



FIGURE 19

13. Locate the date code on both the LH and RH front seatbelt retractors. See Figure 20.

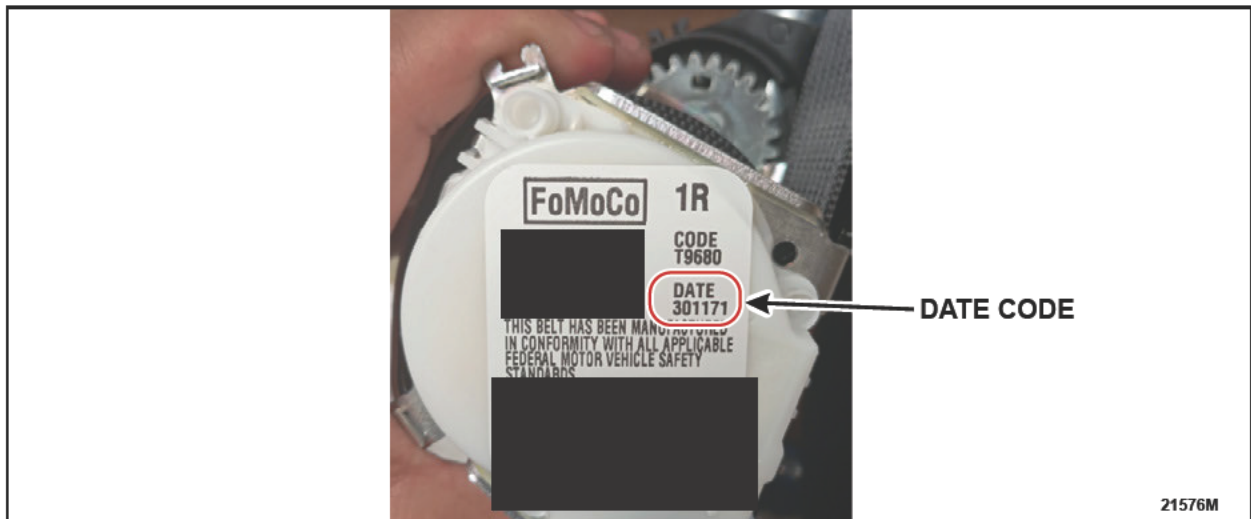

FIGURE 20



14. Do either the LH or RH front seatbelt retractor date codes match any of the following date codes listed in the chart below?

NOTE: The 3rd digit and the 6th digit of the date codes do NOT need to match.

Yes - Replace the front seatbelt retractor(s) that have the suspect date codes. Follow the WSM procedures in Section 501-20A.

No - Replacement is not needed. Reinstall the lower B-pillar trim panels by reversing steps 1 through 10, then continue to step 15.

01*19*	11*19*	21*19*	34*18*	44*18*
02*19*	12*19*	22*19*	35*18*	45*18*
03*19*	13*19*	23*19*	36*18*	46*18*
04*19*	14*19*	24*19*	37*18*	47*18*
05*19*	15*19*	25*19*	38*18*	48*18*
06*19*	16*19*	26*19*	39*18*	49*18*
07*19*	17*19*	27*19*	40*18*	50*18*
08*19*	18*19*	31*18*	41*18*	51*18*
09*19*	19*19*	32*18*	42*18*	52*18*
10*19*	20*19*	33*18*	43*18*	

15. Check the active restraint system for correct operation. Refer to Diagnosis and Testing in WSM Section 501-20A.

IMPORTANT NOTE: Federal law prohibits selling motor vehicle parts or components that are under safety, compliance, or emissions recall. Unless a part is requested to be returned to Ford, all parts replaced under this FSA must be scrapped in accordance with all applicable local, state and federal environmental protection and hazardous material regulations. Refer to the Parts Retention, Return, & Scrapping section of the FSA dealer bulletin for further information.





Ford Motor Company
Ford Customer Service Division
PO Box 1904
Dearborn, Michigan 48121

July 2024

***** IMPORTANT SAFETY RECALL *****

Safety Recall Notice 24S06 / NHTSA Recall 24V099

Mr. John Sample
123 Main Street
Anywhere, USA 12345

This Notice Applies to Your Vehicle, Vehicle Identification Number (VIN): 12345678901234567

This notice is sent to you in accordance with the National Traffic and Motor Vehicle Safety Act. Ford Motor Company has decided that a defect which relates to motor vehicle safety exists in certain 2018-2020 Ford Expedition vehicles, with the VIN shown above.

We apologize for this situation and want to assure you that, with your assistance, we will correct this condition. Our commitment, together with your dealer, is to provide you with the highest level of service and support.

What is the issue? On some of the affected vehicles, the driver and/or front passenger seatbelt retractor pretensioners may deploy inadvertently while the vehicle's engine is on.

What is the risk? Inadvertent deployment of the retractor pretensioner will result in the seatbelt being locked in position and will not retract or extend, which is noticeable to the occupant. A seatbelt that does not retract or extend may result in injury in the event of a crash.

What will Ford and your dealer do? **Parts are now available to repair your vehicle.** Ford Motor Company has authorized your dealer to inspect and, if necessary, replace the front seat belt retractors free of charge (parts and labor).

How long will it take? The time needed for this repair is less than one-half day. However, due to service scheduling requirements, your dealer may need your vehicle for a longer period of time. In addition, your vehicle will require an inspection to determine if parts need to be ordered.

What should you do? Please call your dealer without delay and request a service date for Recall **24S06**. Provide the dealer with your VIN, which is printed near your name at the beginning of this letter.

Ford has not issued instructions to stop driving your vehicle under this safety recall. You should contact your dealer for an appointment to have your vehicle remedied as soon as practicable.

If you do not already have a servicing dealer, you can access  for dealer addresses, maps, and driving instructions.

Ford Motor Company wants you to have this safety recall completed on your vehicle. The vehicle owner is responsible for making arrangements to have the work completed. Ford Motor Company can deny coverage for any vehicle damage that may result from the failure to have this recall performed on a timely basis. Therefore, please have this recall performed as soon as possible.

Please note: Federal law requires that any vehicle lessor receiving this recall notice must forward a copy of this notice to the lessee within ten days.

Pick-Up and Delivery Complimentary vehicle Pick-Up & Delivery service may also be available upon request through participating dealers. Your dealer will pick up your vehicle and return it with the repair completed.

Have you previously paid for this repair? If you have previously paid for a repair that addresses the issue described in this letter, you still need to have this recall performed to ensure the correct parts and procedures were used.

You may be eligible for a refund of previously paid repairs. Refunds will only be provided for service related to front seat belt retractor replacement. To verify eligibility and expedite reimbursement, give your paid original receipt to your dealer.

Refund requests may also be sent directly to Ford Motor Company. To request your refund from Ford, send the refund request with all required documentation, including your original repair receipt (no photocopies), to Ford Motor Company at PO Box 6251, Dearborn, Michigan 48121-6251. Refund requests mailed to this address may take up to 60 days to process. Your original receipt will be returned to you.

Detailed information regarding eligibility for Ford's reimbursement program and documentation requirements may be obtained by contacting the Ford Customer Relationship Center at 1-866-436-7332.

What if you no longer own this vehicle? If you no longer own this vehicle and have an address for the current owner, please forward this letter to the new owner.

You received this notice because government regulations require that notification be sent to the last known owner of record. Our records are based primarily on state registration and title data, which indicate that you are the current owner.

Can we assist you further?

If you have difficulties getting your vehicle repaired promptly and without charge, please contact your dealership's Service Manager for assistance.

RETAIL OWNERS: If you have questions or concerns, please contact our **Ford Customer Relationship Center (CRC) at 1-866-436-7332** and one of our representatives will be happy to assist you. The CRC is open on weekdays from 8:00 AM – 11:00 PM and on Saturday 8:00 AM - 8:00 PM (Eastern Time). TTY/TDD users, please contact the CRC at the number listed using the Telecommunication Relay Service by dialing 711.

If you wish to contact us through the internet, our address is

FLEET OWNERS: If you have questions or concerns, please contact our **Ford Pro Contact Center at 1-800-34-FLEET**, choose Option #1, and one of our representatives will be happy to assist you. If you wish to contact us through the Internet, our address is

Representatives are available Monday through Friday: 7:00 AM – 11:00 PM and Saturday 7:00 AM – 5:00 PM (Eastern Time).

If you are still having difficulty getting your vehicle repaired in a reasonable time or without charge, you may write the Administrator, National Highway Traffic Safety Administration, 1200 New Jersey Ave. S.E., Washington, D.C. 20590 or call the toll-free Vehicle Safety Hotline at 1-888-327-4236 (TTY: 1-800-424-9153) or go to [NHTSA.gov](https://www.nhtsa.gov). Reference NHTSA Safety Recall **24V099**.

Thank you for your attention to this important matter.

Ford Customer Service Division



Lincoln
PO Box 1904
Dearborn, Michigan 48121

July 2024

***** IMPORTANT SAFETY RECALL *****

Safety Recall Notice 24S06 / NHTSA Recall 24V099

Mr. John Sample
123 Main Street
Anywhere, USA 12345

This Notice Applies to Your Vehicle, Vehicle Identification Number (VIN): 12345678901234567

This notice is sent to you in accordance with the National Traffic and Motor Vehicle Safety Act. Lincoln has decided that a defect which relates to motor vehicle safety exists in certain 2018-2020 Lincoln Navigator vehicles, with the VIN shown above.

For this situation and want to assure you, with your assistance, we will correct this condition. Our commitment, together with your retailer, is to provide you with the highest level of service and support.

- What is the issue?** On some of the affected vehicles, the driver and/or front passenger seatbelt retractor pretensioners may deploy inadvertently while the vehicle's engine is on.
- What is the risk?** Inadvertent deployment of the retractor pretensioner will result in the seatbelt being locked in position and will not retract or extend, which is noticeable to the occupant. A seatbelt that does not retract or extend may result in injury in the event of a crash.
- What will Lincoln and your retailer do?** **Parts are now available to repair your vehicle.** Lincoln has authorized your dealer to inspect and, if necessary, replace the front seat belt retractors free of charge (parts and labor).
- How long will it take?** The time needed for this repair is less than one-half day. However, due to service scheduling requirements, your dealer may need your vehicle for a longer period of time. In addition, your vehicle will require an inspection to determine if parts need to be ordered.

What should you do? Please call your retailer without delay to schedule a service appointment for Recall **24S06**. Provide the retailer with your VIN, which is printed near your name at the beginning of this letter.

Lincoln has not issued instructions to stop driving your vehicle under this safety recall. You should contact your retailer for an appointment to have your vehicle remedied as soon as practicable.

If you do not already have a servicing retailer, you can access  for retailer addresses, maps, and driving instructions.

Lincoln wants you to have this safety recall completed on your vehicle. The vehicle owner is responsible for making arrangements to have the work completed. Lincoln can deny coverage for any vehicle damage that may result from the failure to have this recall performed on a timely basis. Therefore, please make arrangements to have this recall performed as soon as possible.

Please note: Federal law requires that any vehicle lessor receiving this recall notice must forward a copy of this notice to the lessee within ten days.

Pick-Up and Delivery Complimentary vehicle Pick-Up & Delivery service may also be available upon request from your retailer. Your retailer will pick up your vehicle and return it with the repair completed.

Have you previously paid for this repair? If you have previously paid for a repair that addresses the issue described in this letter, you still need to have this recall performed to ensure the correct parts and procedures were used.

You may be eligible for a refund of previously paid repairs. Refunds will only be provided for services related to front seat belt inspection/replacement. To verify eligibility and expedite reimbursement, give your paid original receipt to your retailer.

To request your refund directly from Lincoln, send the refund request with all required documentation, including your original repair receipt (no photocopies), to Lincoln at PO Box 6251, Dearborn, Michigan 48121-6251. Refund requests mailed to this address may take up to 60 days to process. Your original receipt will be returned to you.

Detailed information regarding eligibility for Lincoln's reimbursement program and documentation requirements may be obtained by contacting our Customer Relationship Center at 1-866-436-7332.

What if you no longer own this vehicle?

If you no longer own this vehicle and have an address for the current owner, please forward this letter to the new owner.

You received this notice because government regulations require notification to be sent to the last known owner of record. Our records are based primarily on state registration and title data, which indicate you are the current owner.

Can we assist you further?

If you have difficulties getting your vehicle repaired promptly and without charge, please contact your dealership's Service Manager for assistance.

RETAIL OWNERS: If you have questions or concerns, please contact our **Ford Customer Relationship Center (CRC) at 1-866-436-7332** and one of our representatives will be happy to assist you. The CRC is open on weekdays from 8:00 AM – 11:00 PM and on Saturday 8:00 AM - 8:00 PM (Eastern Time). TTY/TDD users, please contact the CRC at the number listed using the Telecommunication Relay Service by dialing 711.

If you wish to contact us through the internet, our address is

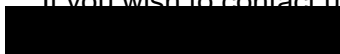

FLEET OWNERS: If you have questions or concerns, please contact our **Ford Pro Contact Center at 1-800-34-FLEET**, choose Option #1, and one of our representatives will be happy to assist you. If you wish to contact us through the Internet, our address is



Representatives are available Monday through Friday: 7:00 AM – 11:00 PM and Saturday 7:00 AM – 5:00 PM (Eastern Time).

If you are still having difficulty getting your vehicle repaired in a reasonable time or without charge, you may write the Administrator, National Highway Traffic Safety Administration, 1200 New Jersey Ave. S.E., Washington, D.C. 20590 or call the toll-free Vehicle Safety Hotline at 1-888-327-4236 (TTY: 1-800-424-9153) or go to [NHTSA.gov](https://www.nhtsa.gov). Reference NHTSA Safety Recall **24V099**.

Thank you for your attention to this important matter.

Lincoln