

RQ24-008 Supplemental IR Request 10 Leak Path Details

October 25, 2024

The Ford logo, rendered in its signature blue script font, is positioned in the bottom right corner of the page.



Fuel Path From Cracked Injector

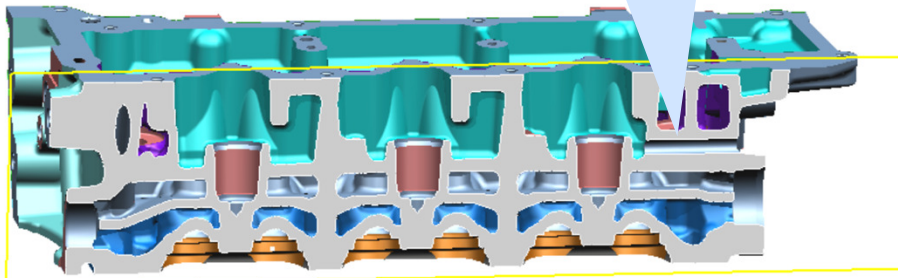
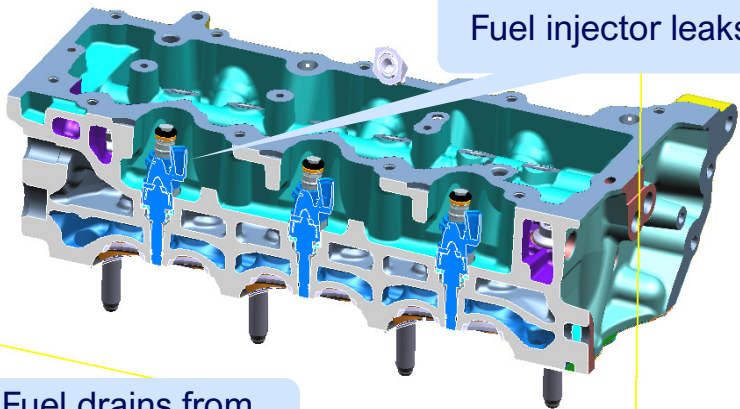

Fuel drains from side of the head

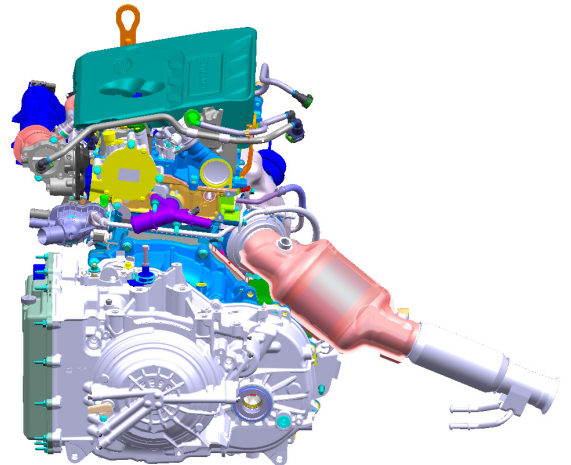
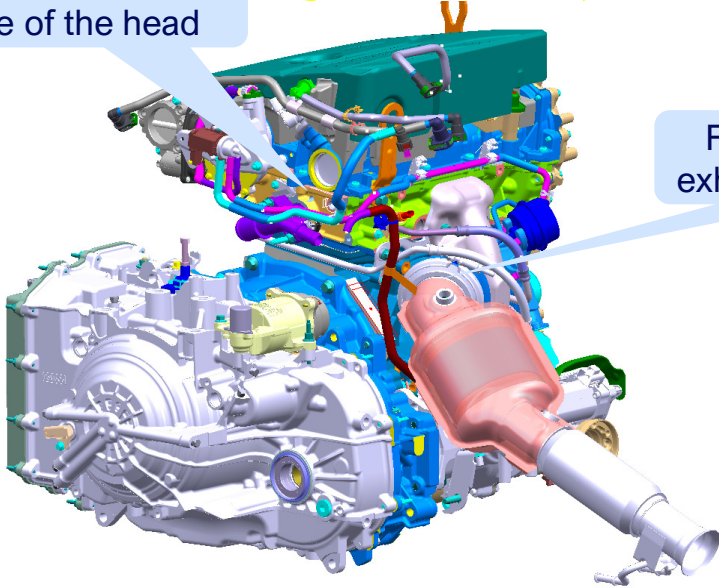

Fuel Path From Cracked Injector Valve Body and thru Modular Power Unit

Crack in valve body

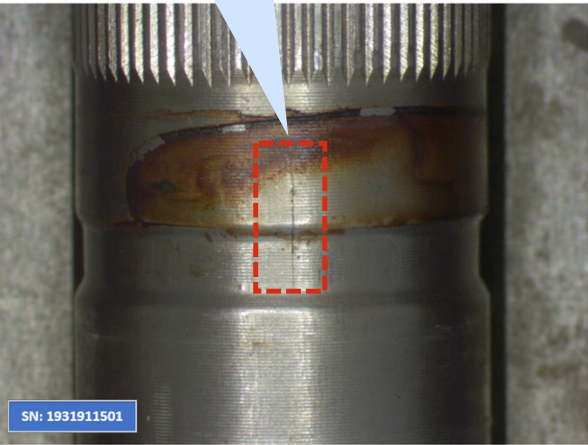

High pressure fuel leaks out of crack in valve body

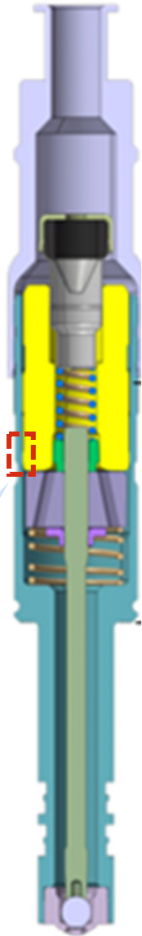

Fuel leaks between the valve body and modular power unit interface

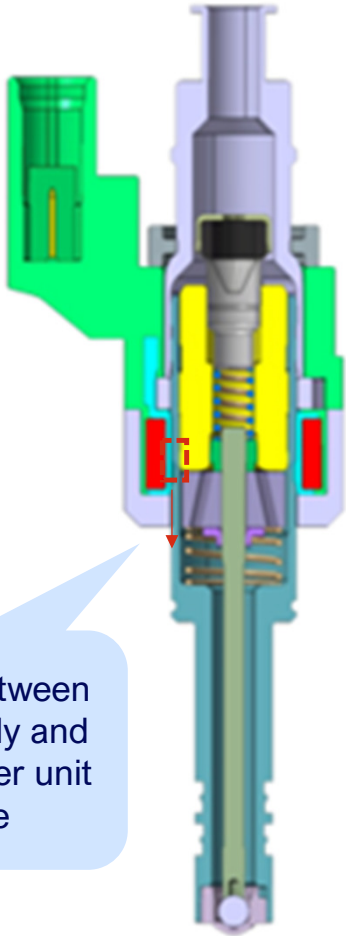

Fuel Path Into Valley

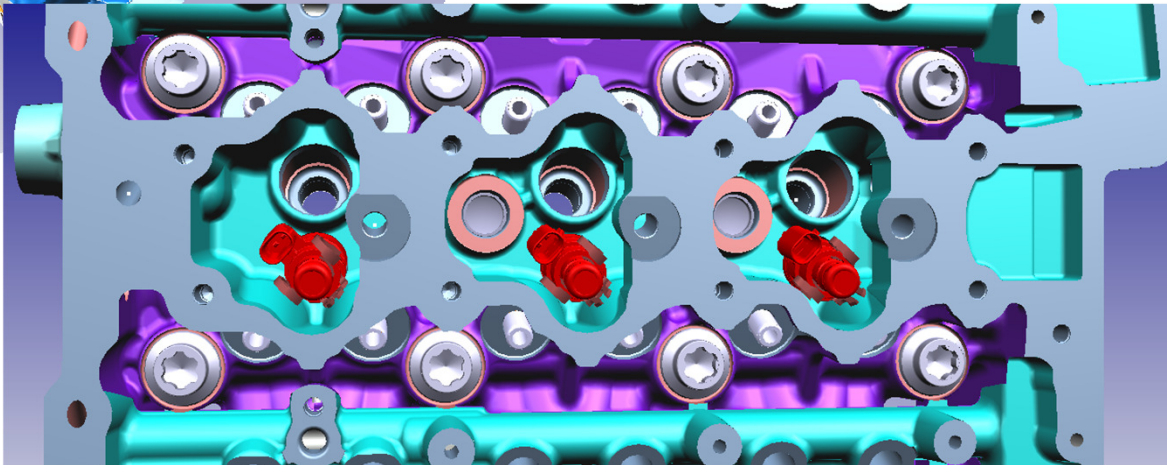
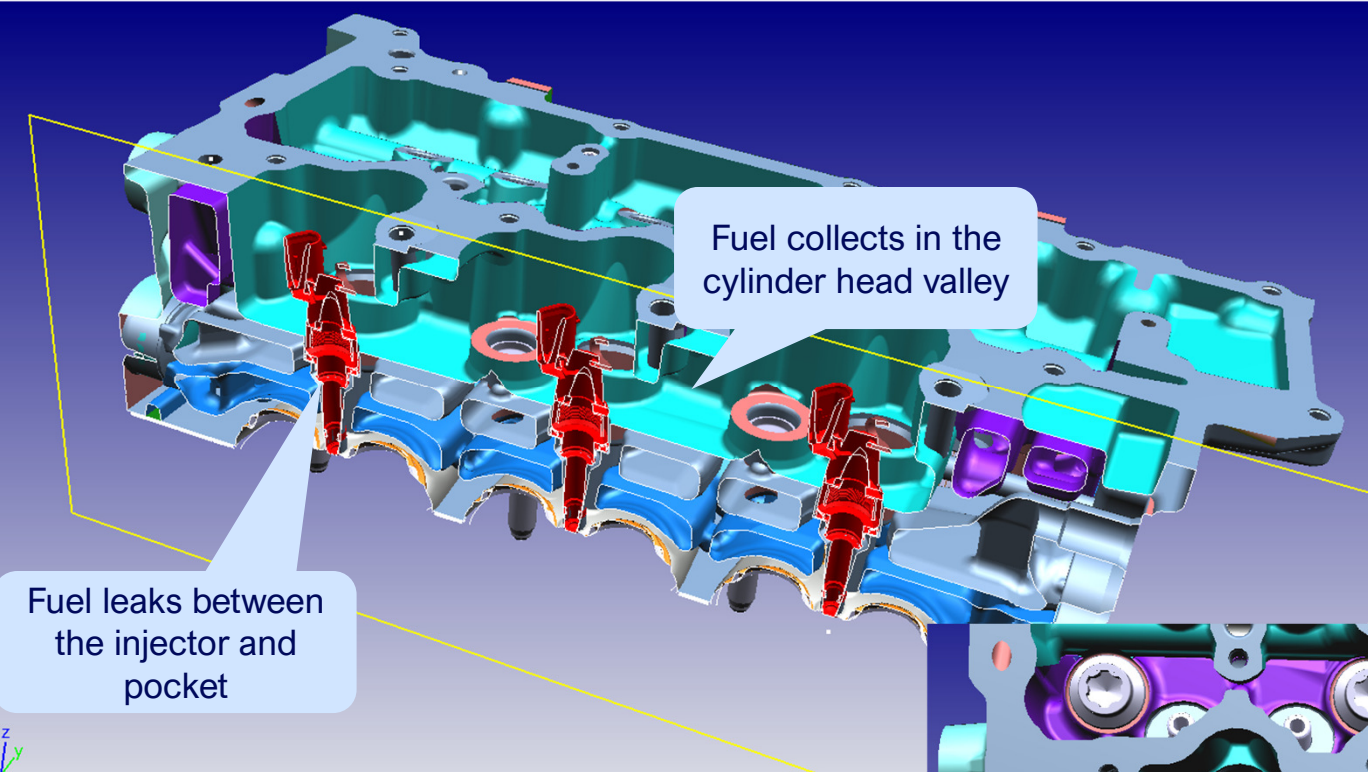

Fuel Path From Valley to Drain Hole

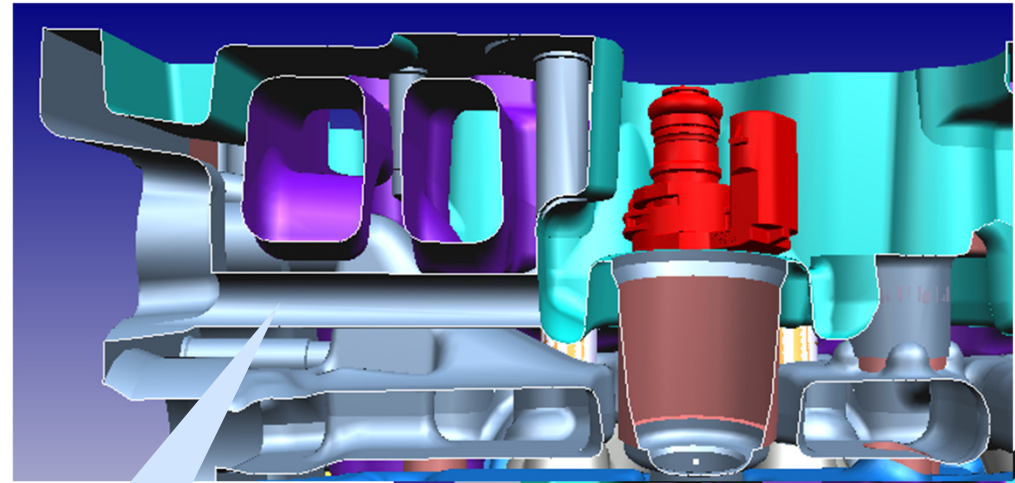

Cylinder head drain

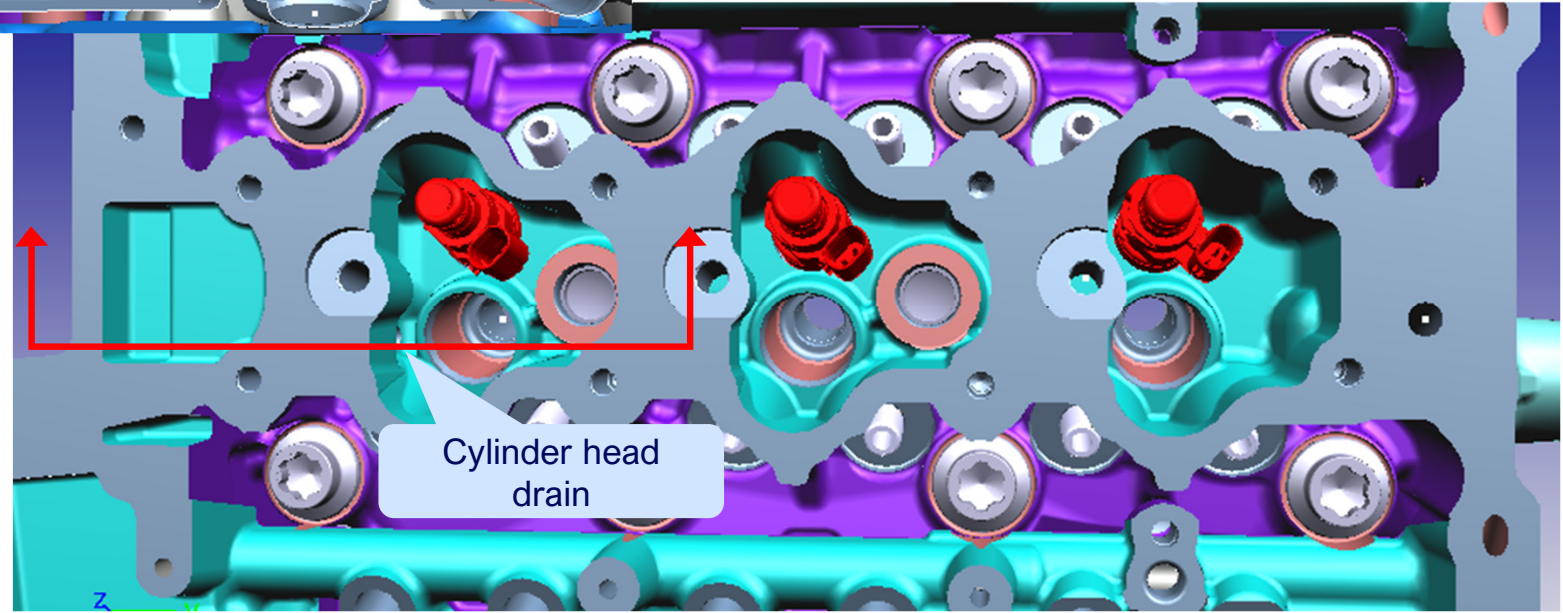

Cylinder head drain