



**Davidson Chevrolet  
Cadillac, Buick, GMC**  
5871 Rome-Taberg Rd  
Rome, NY 13440  
(315) 337-2440

**SERVICE DEPARTMENT HOURS**  
7:30 a.m. to 5:30 p.m.  
Monday - Friday  
R-7027533

R/O Open Date	8/17/22
Time Received	8:23
Current Mileage	24912
Estimate of Repairs	DAVID FLINN/
Time Promised	8/17 17:00
Mileage Out	
Service Advisor / Key Tag #	

CLINTON, NY		Work Phone	Vehicle Identification Number	
Year	Make	Home Phone	Delivery Date	In-Service Date
2017	CHEVROLET			10/22/16
	Model	Body	Color	License Number
	VOLT	5DR HB PREMIER		

Job Number	Description of Work	Code
1.	CHECK ENGINE LIGHT CUSTOMER STATES CHECK ENGINE LIGHT ON~CUSTOMER STATES SES LIGHT ON	10CVZ06 WARR-GENERAL

197

Job Number	Description of Work	Code
2.	MULTIPOINT INSPECT CUSTOMER REQUESTS MULTI POINT INSPECTION MULTI POINT INSPECTION	00CVZ05 WARR-GENERAL

Job Number	Description of Work	Code
3.		

Job Number	Description of Work	Code
4.		

Job Number	Description of Work	Code
5.		

**TERMS: STRICTLY CASH UNLESS ARRANGEMENTS MADE**

"I hereby authorize the repair work above to be done along with the necessary material and agree that you are not responsible for loss or damage to vehicle or articles left in the vehicle in case of fire, theft, or any other cause beyond your control or for any delays caused by unavailability of parts or delays in parts shipments by the supplier or transporter. I hereby grant you or your employees permission to operate the vehicle herein described on streets, highways, or elsewhere for testing and/or inspection. An express mechanic's lien is hereby acknowledged on above vehicle to secure the amount of repairs thereto."

**DISCLAIMER OF WARRANTIES.**

by expressly disclaims all warranties either express or implied, including any implied warranty of merchantability or assume for it any liability in connection with the sale of said products. Any limitation contained herein does not apply

PRELIMINARY ESTIMATE	AUTHORIZED BY:
REVISED ESTIMATE	AUTHORIZED BY: DATE / TIME

ALL PARTS ARE NEW UNLESS OTHERWISE SPECIFIED.

COMPLAINT *Verified C/c*

*CFE on Ford codes.*

CAUSE *U 2603*

*U 2605*

CORRECTION *U 2618.*

*Followed Document # 5107213*

WORK REQUESTED PARTS LABOR TOTAL

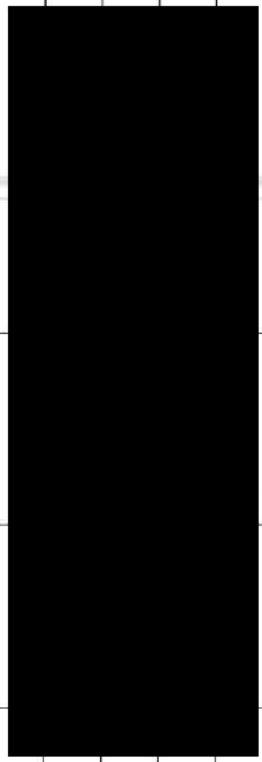

COMPLAINT *Revised battery and*

*Replaced Battery Energy Control module*

*Reprogrammed D2*

CORRECTION

EmpNo: 197

Time

Start

End

EmpNo: 197

Time

Start

End

CORRECTION

*lab's code*

*5031010*

*4.9 R/L*

*1.0 D. Prod*

*1.4 Smoke test*

Date: December 2, 2022

Tech: Robert Perrigo

RONumber Start 09:21 AM

EmpNo: 197

Time

End 10:31 AM

GRAND TOTAL

CLINTON, NY			Home Phone	R/O Open Date	R/O Number
			WORK PHONE	8/17/22	
			Key Tag #	Time Received	Time Promised
				8:23	8/17 17:00
				Current Mileage	Mileage Out
				24912	
Year	Make	Model	Body	Engine Code	Service Advisor
2017	CHEVROLET	VOLT	5DR HB PREMIE	L3A	DAVID FLINN
Vehicle Identification Number		Color	License Number	Delivery Date	In-Service Date
					10/22/16

#1 - 10CVZ06: CHECK ENGINE LIGHT  
 CUSTOMER STATES CHECK ENGINE LIGHT ON~CUSTOMER STA  
 TES SES LIGHT ON  
 C/S: LIGHT ON AGAIN

W  
W  
W  
W

#2 - 00CVZ05: MULTIPOINT INSPECT  
 CUSTOMER REQUESTS MULTI POINT INSPECTION  
 MULTI POINT INSPECTION  
 CREATED 2022-08-09 09:13:00AM TAKEN BY DAVID FLINN

W  
W  
W

CO#	RO#	Date	Miles	Service Writer	Tech	Time	Total
DA1	1654761	8/1/22	24569	DAVID FLINN			465.07
	I 00CVZ:	QUICK SERVICE			197	.00	
	C 50CVZ07:	*R&R BATTERY			197	1.50	
DA1	1639025	4/7/21	19506	DAVID FLINN			1049.26
	W 00CVZ:	QUICK SERVICE			197	.40	
	C 00CVZ:	QUICK SERVICE			197	6.00	
DA1	1628453	6/17/20	18979	LISA CIHOCKI			43.45
	W 66CVZ:	CAMPAIGNS			197	.80	
	C 00CVZZPDEX:	GM DEXOS LOF & ROTATE TIRES			197	.40	

I hereby authorize the repair work above to be done along with the necessary material and agree that you are not responsible for loss or damage to vehicles or articles left in the vehicle in case of fire, theft, or any other cause beyond your control or for any delays caused by unavailability of parts or delays in parts shipments by the supplier or transporter. I hereby grant you or your employees permission to operate the vehicle herein described on streets, highways, or elsewhere for the purpose of testing and/or inspection. An express mechanic's lien is hereby acknowledged on above vehicle to secure the amount of repairs thereto.

Any warranties on products sold hereby are those made by the manufacturer. The seller hereby expressly disclaims all warranties, express or implied, including any implied warranty of merchantability or fitness for a particular purpose, and the seller neither assumes nor authorizes any other person to assume for it liability in connection with the sale of said products. Any Limitation contained herein does not apply where prohibited by law.

(C) 2010 DEALERTRACK SYSTEMS, Inc. - Dealership Application Group (800)945-1028

Customer Signature



CLINTON, NY			Home Phone	R/O Open Date	R/O Number
				8/17/22	
			Work Phone	Time Received	Time Promised
				8:23	8/17 17:00
			Key Tag #	Current Mileage	Mileage Out
				24912	
Year	Make	Model	Body	Engine Code	Service Advisor
2017	CHEVROLET	VOLT	5DR HB PREMIE	L3A	DAVID FLINN
Vehicle Identification Number			Color	License Number	Delivery Date
					10/22/16

#1 - 10CVZ06: CHECK ENGINE LIGHT W  
CUSTOMER STATES CHECK ENGINE LIGHT ON~CUSTOMER STA W  
TES SES LIGHT ON W  
C/S: LIGHT ON AGAIN W

#2 - 00CVZ05: MULTIPOINT INSPECT W  
CUSTOMER REQUESTS MULTI POINT INSPECTION W  
MULTI POINT INSPECTION W  
CREATED 2022-08-09 09:13:00AM TAKEN BY DAVID FLINN

CO#	RO#	Date	Miles	Service Writer	Tech	Time	Total
DA1	1654761	8/1/22	24569	DAVID FLINN			465.07
	I	00CVZ: QUICK SERVICE			197	.00	
	C	50CVZ07: *R&R BATTERY			197	1.50	
DA1	1639025	4/7/21	19506	DAVID FLINN			1049.26
	W	00CVZ: QUICK SERVICE			197	.40	
	C	00CVZ: QUICK SERVICE			197	6.00	
DA1	1628453	6/17/20	18979	LISA CIHOCKI			43.45
	W	66CVZ: CAMPAIGNS			197	.80	
	C	00CVZZPDEX: GM DEXOS LOF & ROTATE TIRES			197	.40	

I hereby authorize the repair work above to be done along with the necessary material and agree that you are not responsible for loss or damage to vehicle or articles left in the vehicle in case of fire, theft, or any other cause beyond your control or for any delays caused by unavailability of parts or delays in parts shipment by the supplier or transporter. I hereby grant you or your employees permission to operate the vehicle herein described on streets, highways, or elsewhere for the purpose of testing and/or inspection. An express mechanic's lien is hereby acknowledged on above vehicle to secure the amount of repairs thereto.

Any warranties on products sold hereby are those made by the manufacturer. The seller hereby expressly disclaims all warranties, express or implied, including any implied warranty of merchantability or fitness for a particular purpose, and the seller neither assumes nor authorizes any other person to assume for it liability in connection with the sale of said products. Any limitation contained herein does not apply where prohibited by law.



# VEHICLE REPORT

2017 Chevrolet Volt

VIN [REDACTED]

Odometer: 24,912 mi



SERVICE WORKBENCH

DAVIDSON AUTOMOTIVE

## OnStar Alerts

Alert Title	Alert Description
Oil life	96.078465% at 8/17/2022 12:19 PM

## Subscription Statuses

OnStar Status: ✓ Equipped & Active

Advanced Diagnostics Report: ✓ Yes

DMN Enabled: ✓ Yes

Radio Status: ⚠ Equipped & Inactive

Radio ID: [REDACTED]

Owner Center Status: ⚠ Insufficient customer information

My Rewards Status: ⚠ Insufficient customer information

## Most Recent Services

Status	Description	Date	Type
✗ DECLINED		6/26/2018	Menu
⚠ May Require Attention Soon	Engine oil	6/26/2018	MPVI

## Previous Visit

Date: 6/26/2018

Odometer: 14,243 mi

Driving Conditions: Normal

## Required Field Actions

Status	Type	Number	Description	Release Date
Closed - Dealer Repaired	Customer Satisfaction Program	N202307990	Increased Customer Notification	4/14/2021
Closed - Dealer Repaired	Product Emission Recall	N192273600	Emissions Pipe May Rub Against A/C Hose Connector	3/25/2020
Closed - Dealer Repaired	Customer Satisfaction Program	16185	No Start or Loss of Propulsion - Expires 9/30/19	8/15/2017
Closed - Dealer Repaired	Service Update Bulletin	17197	Malfunction Indicator Lamp	6/28/2017
Closed - Dealer Repaired	Service Update Bulletin	17058	P2097 (Post O2 Trim Diagnostic) False Failing	2/10/2017
Closed - Dealer Repaired	Service Update Bulletin	39570	Front Camera Freezes	1/17/2017
Closed - Dealer Repaired	Customer Satisfaction Program	16055	Reduced Propulsion Power	12/5/2016
Closed - Dealer Repaired	Service Update Bulletin	16017	Battery Cable Misaligned	9/21/2016

## Service Contracts

Printed on: 8/17/2022 8:24 AM

Please Note: This document may be considered current for 24 hours from the time it was printed

Copyright 2022 General Motors. All Rights Reserved. All text, images and other content in this document are subject to the copyright and other intellectual property rights of GM. These materials may not be reproduced, distributed, or modified without the express written permission of GM.

# VEHICLE REPORT

2017 Chevrolet Volt

V [REDACTED]

Odometer: 24,912 mi



DAVIDSON AUTOMOTIVE

No information found for this vehicle

## Service Information

No information found for this vehicle

## Vehicle Warranty Claim History (From IVH)

Service Date	R.O. Number	Transaction Type	Op Code	Description	Odometer Reading	Service Type
4/9/2021	[REDACTED]	ZFAT	9105392	N202307990 - Hybrid Powertrain Control Module 2 Reprogramming with SPS	19506 mi	Warranty
6/17/2020	[REDACTED]	ZFAT	9104663	N192273600 - Install Three Tie Wraps on Evaporative Hose Bumper	18979 mi	Warranty
6/26/2018	[REDACTED]	ZREG	0600723	Chevrolet Factory Maintenance	14243 mi	Warranty
8/28/2017	[REDACTED]	ZFAT	9102930	Replace Fuse and Reprogram Hybrid Powertrain Control Module 2 - For use with IVH Ref # N162070470	7576 mi	Warranty
8/16/2017	[REDACTED]	ZFAT	9103186	17197 - Inspect Evaporative Emission Pipe and/or Install Evaporative Emission Hose Protector - No Fu	7330 mi	Warranty
7/26/2017	[REDACTED]	ZFAT	9102665	39570 - Front View Camera Reprogramming with SPS	6878 mi	Warranty
7/26/2017	[REDACTED]	ZFAT	9102988	FA 17058 - Drive Motor Power Inverter Module Reprogramming with SPS	6878 mi	Warranty
7/26/2017	[REDACTED]	ZREG	2810325	Radio Control Reprogramming with SPS	6878 mi	Warranty
1/10/2017	[REDACTED]	ZFAT	9102569	2016017 - Verify Battery Cable Connection at Under Hood Fuse Block	2161 mi	Warranty
1/10/2017	[REDACTED]	ZFAT	9102609	16055 - Hybrid Powertrain Control Module 2 Reprogramming with SPS	2161 mi	Warranty
6/19/2016	[REDACTED]	ZPDI	0590072	Pre-Delivery Inspection - Base Time	1 mi	Warranty

## Applicable Warranties

Description	Effective Date	Effective Odometer	End Date	End Odometer	Warranty Status
Bumper to Bumper Limited Warranty	10/22/2016	201 mi	10/22/2019	36201 mi	✘ Expired
Powertrain Limited Warranty	10/22/2016	201 mi	10/22/2021	60201 mi	✘ Expired
Corrosion Limited Warranty	10/22/2016	201 mi	10/22/2022	100201 mi	✔ Applicable
Voltec Component Limited Warranty	10/22/2016	201 mi	10/22/2024	100201 mi	✔ Applicable
Chevrolet Scheduled Maintenance-2 visits	10/22/2016	201 mi	10/22/2018	24201 mi	✘ Expired
Emission Select Component Ltd Wty	10/22/2016	201 mi	10/22/2024	80201 mi	✔ Applicable

Printed on: 8/17/2022 8:24 AM

Please Note: This document may be considered current for 24 hours from the time it was printed

Copyright 2022 General Motors. All Rights Reserved. All text, images and other content in this document are subject to the copyright and other intellectual property rights of GM. These materials may not be reproduced, distributed, or modified without the express written permission of GM.

SE5020R

DAVIDSON CHEVROLET INC

8/17/22

Manufacture: GM Type: GMVIS2 Fi



Soap Fault:

Fault String:

Fault Factor:

Err Details:

\*\*\*\*End Of Report\*\*\*\*

-----



SE5020R

DAVIDSON CHEVROLET INC

8/17/22

Manufacture: GM Type: GMVIS2 File



Soap Fault:

Fault String:

Fault Factor:

Err Details:

\*\*\*\*End Of Report\*\*\*\*

-----



# VEHICLE REPORT

2017 Chevrolet Volt

VIN

Odometer: 24,912 mi



SERVICE WORKBENCH

DAVIDSON AUTOMOTIVE

## Repair Order History (From Dealer Management Systems)

★ Indicates work performed at this dealership

	R.O. Closure Date	R.O. Number	Service Location	1st R.O. Job Description	R.O. Job Count	Job Type Indicators	Vehicle R.O. Mileage
★	8/3/2022		NY	QUICK SERVICE	2	C, I	24569 mi
★	4/9/2021		NY	QUICK SERVICE	4	C, W	19506 mi
★	6/19/2020		NY	CAMPAIGNS	4	C, W	18979 mi
	6/26/2018		FL	CHEVROLET 2 YEAR SCHEDULED MAINTENANCE PROGRAM INCLUDES OIL & FILTER CHANGE, TIRE ROTATION, 27 MULTI POINT INSPECTION	4	C, I, W	14243 mi
	8/28/2017		FL	Replace Fuse and Reprogram Hybrid Powertrain Control Modul	3	C, W	7576 mi
	8/16/2017		FL	Inspect Evaporative Emission Pipe and/or Install Evaporati	3	C, W	7330 mi
	7/26/2017		FL	RADIO CONTROL REPROGRAMMING WITH SPS	5	C, W	6878 mi
	1/10/2017		FL	Hybrid Powertrain Control Module 2 Reprogramming with SPS	4	C, W	2161 mi

Printed on: 8/17/2022 8:24 AM

Please Note: This document may be considered current for 24 hours from the time it was printed

Copyright 2022 General Motors. All Rights Reserved. All text, images and other content in this document are subject to the copyright and other intellectual property rights of GM. These materials may not be reproduced, distributed, or modified without the express written permission of GM.





**CUSTOMER INFORMATION**

Customer: [Redacted]  
 Home Address: [Redacted]  
 City: [Redacted] State: [Redacted] Zip: [Redacted]  
 Driver's License No.: [Redacted] State: [Redacted] Expires: [Redacted]  
 Birth Date: [Redacted] Telephone: [Redacted]

PO# [Redacted] Unit# [Redacted] RA# [Redacted]  
 Service Advisor: David Flinn PO [Redacted]

**VEHICLE INFORMATION**

Date and time OUT: Oct 7th 2022, 10:10:18 AM Date and time IN: [Redacted]  
 Date and time DUE IN: 10/10/2022  
 Birth Date: [Redacted] Telephone: [Redacted]

**ONLY THE BELOW NAMED PERSONS ARE AUTHORIZED AS ADDITIONAL DRIVERS. IF NONE, PRINT "NONE" ACROSS THIS SECTION AND HAVE SIGNED BY CUSTOMER.**

Additional Driver's Name	Birth Date	Year	Make
Driver's License No.	State	Expires	Model
Additional Driver's Name	Birth Date	Tag #	
Driver's License No.	State	Expires	Miles Allowed

**CUSTOMER INSURANCE INFORMATION**

Insurer: [Redacted] Policy No.: [Redacted] Expiration Date: [Redacted]  
 Agent: [Redacted] Telephone: [Redacted]  
 Insured Vehicle Year/Make/Model/Color: [Redacted]  
 License No.: [Redacted] State: [Redacted]

Mileage OUT: 25828 Mileage IN: [Redacted]  
 Miles Driven: [Redacted] Chargeable Miles: [Redacted]

**FUEL**

OUT: 100%  
 IN: [Redacted]

PERMISSION TO TOW TRAILER WITH LOAD CAPACITY IN EXCESS OF 2,000 POUNDS; NOT TO EXCEED MANUFACTURER'S WEIGHT SPECIFICATIONS.

You are required to return the Vehicle with at least the same amount of fuel as when rented. If you do not return the Vehicle with at least the same amount of fuel; you will pay us a refueling fee of \$ \_\_\_\_\_ plus fuel @ \$ \_\_\_\_\_ per gallon.

Unless otherwise noted, any daily rate is based on a 24-hour period.

You consent to our placing an authorization hold or reserve on your payment card in the amount of \$ \_\_\_\_\_. Initials \_\_\_\_\_.

The following are "Prohibited Uses": Use by an unauthorized driver; smoking, vaping or use of tobacco products in the Vehicle; use of the Vehicle by anyone under the influence of alcohol or prescription or non-prescription drugs; and carrying persons or property for hire or providing transportation network company or other transportation services. See Paragraph 6 of the Terms and Conditions for other Prohibited Uses and additional information.

By signing below, you: agree to the terms and conditions of this Agreement set forth on this Face Page, the Vehicle Condition Report, and all pages of the Vehicle Use Terms and Conditions; acknowledge that you had an opportunity to read the entire Agreement before signing; authorize us to process a separate payment card voucher in your name for all Charges, including Tolls and Violations and to release your billing/rental information to third parties for billing/processing; and, if you are using a credit card, authorize us to charge your payment card the amount noted in this agreement and further described in Section 2 of the Terms and Conditions; and, if you are using a debit card, authorize us to charge your payment card account to reflect charges. ALL CHARGES SUBJECT TO FINAL AUDIT

RATES DO NOT INCLUDE FUEL		CHARGES
HOURS: _____ @ \$ _____ PER HOUR		
DAYS: _____ @ \$ _____		
WEEKS: _____ @ \$ _____		
MILES: _____ @ _____¢ PER MILE		
<b>TOTAL TIME &amp; MILEAGE CHARGES</b> →		
TAXABLE FUEL _____ GAL. @ \$ _____		
VEHICLE LICENSE FEE		
<b>TAXABLE SUB-TOTAL</b> →		
TAX @ _____%		
NON-TAXABLE FUEL _____ GAL. @ \$ _____		
VEHICLE LICENSE FEE		
NET DUE CUSTOMER DEPOSIT / REFUND / OTHER		
<b>SUB-TOTAL</b>		
<b>TOTAL CHARGE</b> →		
<b>METHOD OF PAYMENT</b>		<b>REFUNDED</b>
<input type="checkbox"/> CHECK		\$ _____
<input type="checkbox"/> AMEX <input type="checkbox"/> MC		CUSTOMER INITIALS
<input type="checkbox"/> VISA <input type="checkbox"/> OTHER		X _____
_____/_____/_____ EXPIRES		
<input type="checkbox"/> CARD VERIFIED		

VEHICLE REPORT

Condition OUT:

Condition IN:

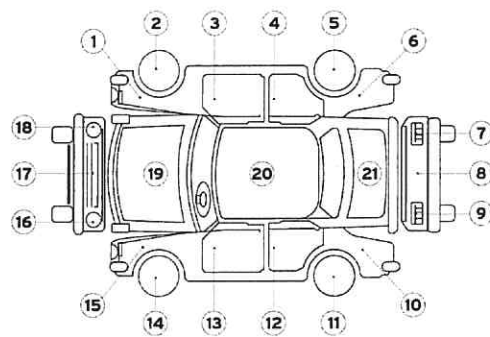
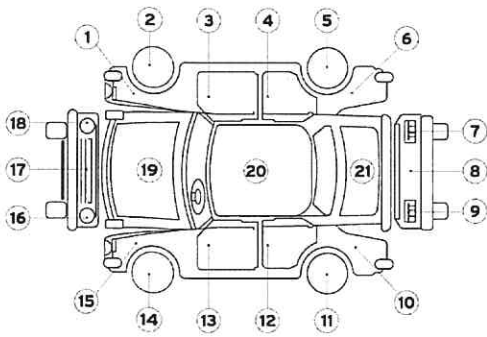

Signature: \_\_\_\_\_ Date: \_\_\_\_\_

Signature: \_\_\_\_\_ Date: \_\_\_\_\_

## New York Vehicle Use Agreement Terms and Conditions ("Terms and Conditions")

1. **Definitions.** "Agreement" means all terms and conditions found on the "Face Page" and on all pages of these Terms and Conditions. "You" or "your" means the person identified as the Customer on the Face Page, each person signing this Agreement, every Authorized Driver and each person or organization to whom charges are billed by us at its or the Customer's direction. You are jointly and severally bound by this Agreement. "We," "us" or "our" means the independent automobile dealer or its affiliate named elsewhere in this Agreement. "Vehicle" means the automobile or truck identified in this Agreement and each vehicle we substitute for it, and all its tires, tools, accessories, equipment, keys and documents. The Vehicle may be a temporary substitute for a Customer-owned or Customer-leased vehicle that you have given us the opportunity to service or repair ("Service Replacement Vehicle"). "Rental Period" means the period from the time you take possession of the Vehicle until the time that the Vehicle is either returned to or recovered by and checked in by us. "Charges" means the fees and charges that are incurred under this Agreement.

2. **Nature of Contract; Consideration; Indemnity and Warranties.** This Agreement is a contract for rental of the Vehicle offered to you. This rental is solely a bailment for mutual consideration. By signing the Face Page, you agree to all terms and conditions of this Agreement and acknowledge that binding consideration exists, as follows: our opportunity to service or repair a vehicle you left with us; financial benefits we receive from others for the service/repair work; financial benefits we receive from others to obtain and use this Vehicle as a Service Replacement Vehicle; a fee you pay us; and/or the rights and obligations of this Agreement. **To the extent permitted by law, you: (a) agree to indemnify us, defend us and hold us harmless from all claims, liability, costs and attorney fees we incur resulting from or arising out of this Agreement or your use of the Vehicle; and (b) we make no warranties, express, implied or apparent, regarding the Vehicle, no warranty of merchantability and no warranty that the Vehicle is fit for a particular purpose.**

3. **Authorized Drivers.** You represent that you are a capable and validly licensed driver.

(a) **Definition.** "Authorized Driver" means: (i) the Customer and the Customer's spouse or domestic partner; (ii) additional drivers listed by us in this Agreement; (iii) if the Customer is a business entity, "Authorized Driver" includes Customer employees who are permissible drivers on the business entity's auto insurance policy; (iv) the Customer's employer, employee or coworker who is engaged in a common business activity with the Customer; (v) a licensed driver driving the Vehicle to a medical or police facility during an emergency; and (vi) a person who parks the Vehicle in a commercial establishment. (b) **Requirements.** Each Authorized Driver must possess a valid driver's license and meet our age restrictions: (i) the Customer and the Customer's spouse or domestic partner must be at least age 18; and (ii) an Authorized Driver defined in paragraphs 3(a)(ii) through 3(a)(iv) must be at least age 21. There are no minimum age requirements for Authorized Drivers defined in Paragraphs 3(a)(v) and 3(a)(vi). **Authorized Drivers are the only persons permitted to drive the Vehicle.**

4. **Inspection; Condition and Return of Vehicle.** You must return the Vehicle to our office on the date and time specified on the Face Page (or sooner upon our demand) with at least as much fuel as when rented, unless we offer, and you purchase, pre-paid fuel. We may repossess the Vehicle at your expense without notice to you if the Vehicle is abandoned or used in violation of law or this Agreement. You may extend the Rental Period for up to one week if you obtain our consent before the date due, and we may require you to return the Vehicle to our office for inspection. The total Rental Period may not exceed 30 days under any circumstances. The Vehicle must be returned in the same condition that you received it except for ordinary wear. If the Vehicle is returned after closing hours, you remain responsible for all damage to or loss of it until we inspect it on reopening for business, and Charges may continue to accrue. You must obtain our prior written approval before servicing the Vehicle or replacing parts or accessories. You will check and maintain Vehicle fluid levels. You grant us, our agents, assigns and each person with a financial interest in the Vehicle the right to inspect the Vehicle during the Rental Period.

5. **Responsibility for Damage or Loss; Reporting to Police.** You are responsible for (a) all physical damage to the Vehicle (other than "normal wear and tear" as defined by NY Gen. Bus. Law §396-z), whether or not you are at fault; (b) mechanical damage to the Vehicle (other than mechanical damage that could reasonably be expected from normal use of the Vehicle); and (c) theft of the Vehicle if established that an Authorized Driver failed to exercise reasonable care or that an Authorized Driver committed, aided, or abetted in the theft. Your responsibility for physical and mechanical damage will not exceed the lesser of: (a) the cost to repair the Vehicle including all discounts and price adjustments available to us plus costs for towing, storage, and impound where applicable; (b) the reasonable costs that would have been incurred to repair the Vehicle if we elect not to repair; or (c) the fair market value of the Vehicle immediately before the damage (as determined in the applicable market for the retail sale of the Vehicle), less net disposal proceeds. Your responsibility for theft of the Vehicle will not exceed the reasonable costs incurred by us for the loss, up to the Vehicle's fair market value (as determined by the applicable market for the retail sale of the Vehicle). You must report all accidents or incidents of theft and vandalism to us and the police as soon as you discover them.

6. **Prohibited Uses.** The following uses of the Vehicle are prohibited and constitute material breaches of this Agreement. The Vehicle shall not be used: (a) by anyone who is not an Authorized Driver or not licensed to drive, or by anyone whose driving license is suspended; (b) by anyone under the influence of alcohol or prescription or non-prescription drugs; (c) by anyone who obtained the Vehicle or extended the Rental Period by giving us false, fraudulent or misleading information; (d) for an illegal purpose or in the commission of a felony or other crime; (e) to carry persons or property for hire or to provide transportation network company or other transportation services; (f) to tow an object in excess of 2,000 pounds, unless specifically approved by notation on the Face Page, or to push anything; (g) in a race or speed contest; (h) to teach anyone to drive; (i) outside the United States or Canada, or outside the geographic area described elsewhere in this Agreement, if any; (j) on an unpaved surface; (k) when the odometer has been tampered with or disconnected; (l) when it is reasonable to expect you to know that further operation of the Vehicle would damage it; (m) if applicable, by anyone who lacks experience driving a vehicle with manual transmission; (n) to transport an animal (other than a service animal); (o) to carry more passengers than the number of existing seatbelts; (p) by anyone driving or operating the Vehicle while using a hand-held wireless communication device (or other device that is capable of receiving or transmitting telephonic communications, electronic data, mail or text messages) while not in a hands-free mode; (q) in a willful or reckless manner or to intentionally damage the Vehicle or cause injury or property damage to others; or (r) by anyone who is smoking tobacco products in the Vehicle. **PROHIBITED USE OF THE VEHICLE VIOLATES THIS AGREEMENT AND VOIDS OTHER INSURANCE COVERAGE (TO THE EXTENT PERMITTED BY LAW).**

Cust

7. **Insurance.** You are responsible for all damage or loss you cause to others. You agree to maintain automobile insurance during the term of this Agreement which provides to the owner, to us, and to you, the following primary coverage: (a) Bodily injury ("BI") and property damage ("PD") liability coverage; (b) Personal injury protection ("PIP"), no-fault, or similar coverage where required; and (c) Uninsured/underinsured ("UM"/"UIM") coverage where required. Your insurance coverage will provide at least the minimum limits of coverage required by the financial responsibility laws of the state where the loss occurs. **Where permitted by law, by signing this Agreement, you reject UM, UIM, and supplemental no-fault or PIP coverages.** Where we are required to provide such coverage, you hereby select the minimum limits required by law. Because you are providing auto insurance, we are not. In states where the law requires us to provide insurance, your insurance will be primary. Any insurance we are required to provide applies only to claims of accidental BI and PD resulting from the use of the auto, and is excess to any other valid and collectible insurance whether primary, secondary, excess or contingent. Our insurance policy contains exclusions, conditions, and limitations applicable to anyone claiming coverage. You agree to cooperate with our insurer if any claim is made, and give us immediate notice of damage, claim, or lawsuit against you. Our insurance applies only in the United States and Canada. Engaging in a Prohibited Use described in paragraph 6 or any other material breach of this Agreement will void any insurance coverage.

8. **Reserve; Charges.** You permit us to reserve against your payment card at the time of rental a reasonable amount in addition to estimated total charges. We may use the reserve to pay all Charges. We will authorize the release of any excess reserve upon the completion of your rental. Your payment card issuer's rules will apply to your credit line or account being credited for the excess, which may not be immediately released by your card issuer. You will pay us all Charges, including: (a) taxes, surcharges, and other fees; (b) a return check fee if you pay us with a check returned unpaid; (c) all expenses we incur recovering the Vehicle if it is not returned to the renting location on the date and time promised; (d) all costs we incur collecting payment from you or otherwise enforcing our rights under this Agreement; (e) a late fee on all Charges that are not paid when due; (f) a reasonable fee to clean the Vehicle if it is returned with evidence of smoking, vaping, or animals or otherwise substantially less clean than when received by you; (g) fuel and a refueling fee if you return the Vehicle with less fuel than when received by you; (h) applicable time and mileage fee; (i) a mileage charge based on our experience if the odometer is tampered with; (j) towing, storage charges, Tolls, Violations, forfeitures, court costs, penalties and all other costs we incur resulting from your use of the Vehicle; (k) a reasonable fee if you lose the keys, key fob, or toll transponder to the Vehicle; and (l) a surcharge if you do not return the Vehicle on the date and time and to the location specified on the Face Page. **All Charges are subject to our final audit.**

9. **Responsibility for Tolls, Traffic Violations, and Other Charges.** You are liable for all tolls ("Tolls") and parking citations, photo enforcement fees, fines for toll evasion, and other fines, fees, and penalties (each a "Violation") assessed against you, us or the Vehicle during the Rental Period. If we are notified by charging authorities that we may be responsible for payment of a Toll or Violation, you agree that we or a processing firm ("Processor") may, in our sole discretion and without prior notice to you, pay the Toll or Violation plus applicable taxes on your behalf directly to the appropriate authority. If we or a Processor elect to pay a Toll or Violation, you may not be able to challenge the validity of the Toll or Violation before the charging authority. We or the Processor will charge you the face value of the Toll or Violation and any taxes, plus an administrative fee per Toll and Violation. If we or a Processor, in our sole discretion, elect to transfer liability for a Toll or Violation assessed against the Vehicle during the Rental Period to you personally, we or the Processor will charge you an administrative fee per Toll or Violation. You authorize us to release your rental and payment card information to the charging authorities and the Processor for processing and billing purposes. If we or the Processor pay a Toll or Violation, you authorize us and the Processor to charge all payments and administrative fees to the payment card you used in connection with this Agreement. **Certain toll roads do not accept cash.** To avoid toll violations and associated fines, fees, and taxes (and our administrative fees), you must pay all tolls with a personal transponder that is accepted on the road; use only cash lanes and pay cash; plan a route to avoid tolls; or consult local authorities for other payment methods.

10. **Personal Property and Information.** To the extent permitted by law, you release us, our agents, and our employees from all claims for loss of or damage to personal property that was left with us or carried in the Vehicle. If you fail to claim property left in the Vehicle for more than 30 days, we may dispose of that property in a manner we choose. You agree that we may disclose personally identifiable information about you to applicable law enforcement agencies or to our affiliates or third parties in connection with enforcement of our rights under this Agreement and for other legitimate business purposes. **The Vehicle may be equipped with an infotainment system that permits you to pair your own mobile devices, and which may download your personal contacts, communications, location or other digital data. You should wipe all personal information from the Vehicle's systems before returning it.**

11. **Telematics Notice and Release.** You acknowledge that the Vehicle may be equipped with global positioning satellite ("GPS") technology, OnStar or another telematics system, and/or an event data recorder (collectively, "Telematics System"). Your use of this Vehicle may be remotely monitored by us or on behalf of us through such systems to the extent permitted by law. This remote monitoring may include the collection of Vehicle data, such as: location, odometer, oil life, fuel level, tire pressure, battery state of charge, diagnostic trouble codes, as well as other elements we may deem necessary. You acknowledge that these systems may use cellular telephone, wireless technology, or radio signals to transmit data, and therefore you should have no expectation of privacy related to the use of this Vehicle. You shall inform any and all drivers and passengers of the Vehicle of the terms of this paragraph. We are not responsible for the operability of any Telematics System included with the Vehicle. To the extent permitted by law, you agree to release and indemnify, defend and hold us, the operator of the Telematics System, wireless carriers, and other suppliers of components or services harmless from any damage to persons or property caused by failure of a Telematics System to operate properly, or otherwise arising from the use of the Telematics System.

12. **Miscellaneous.** No term of this Agreement can be waived or modified except by a writing that we have signed or on a form that we provide. This Agreement constitutes the entire agreement between you and us. All prior representations and agreements between you and us regarding the use of the Vehicle are void. Our waiver of a breach of this Agreement, our acceptance of payment from you, or our failure, refusal or neglect to exercise our rights under this Agreement does not constitute a waiver of another provision of this Agreement. You waive all recourse against us for criminal prosecutions we take against you for breach of this Agreement. **TO THE EXTENT PERMITTED BY LAW, YOU RELEASE US FROM ALL LIABILITY FOR CONSEQUENTIAL, SPECIAL OR PUNITIVE DAMAGES IN CONNECTION WITH THIS TRANSACTION OR THE RESERVATION OR USE OF A VEHICLE.** If a provision of this Agreement is deemed void the remaining provisions are valid and enforceable.



FS-20 NEW YORK STATE INSURANCE IDENTIFICATION CARD

ICC: 639 GEICO GENERAL INSURANCE COMPANY

Name & address of Issuer:

GEICO GENERAL INSURANCE COMPANY

ONE GEICO PLAZA

WASHINGTON, DC 20076-0001

1-800-841-3000



Effective Date

08/19/2022 12:01 a.m.

Expiration Date

02/19/2023 12:01 a.m.

An authorized NEW YORK insurer has issued an Owner's Policy of Liability Insurance complying with Article 6 (Motor Vehicle Financial Security Act) of the NEW YORK Vehicle and Traffic Law to:

Insured



CLINTON NY

[View All Active Drivers](#)

Applicable with respect to the following Motor Vehicle  
Vehicle Identification Number



Year  
2017

Make  
CHEV

Model  
VOLT



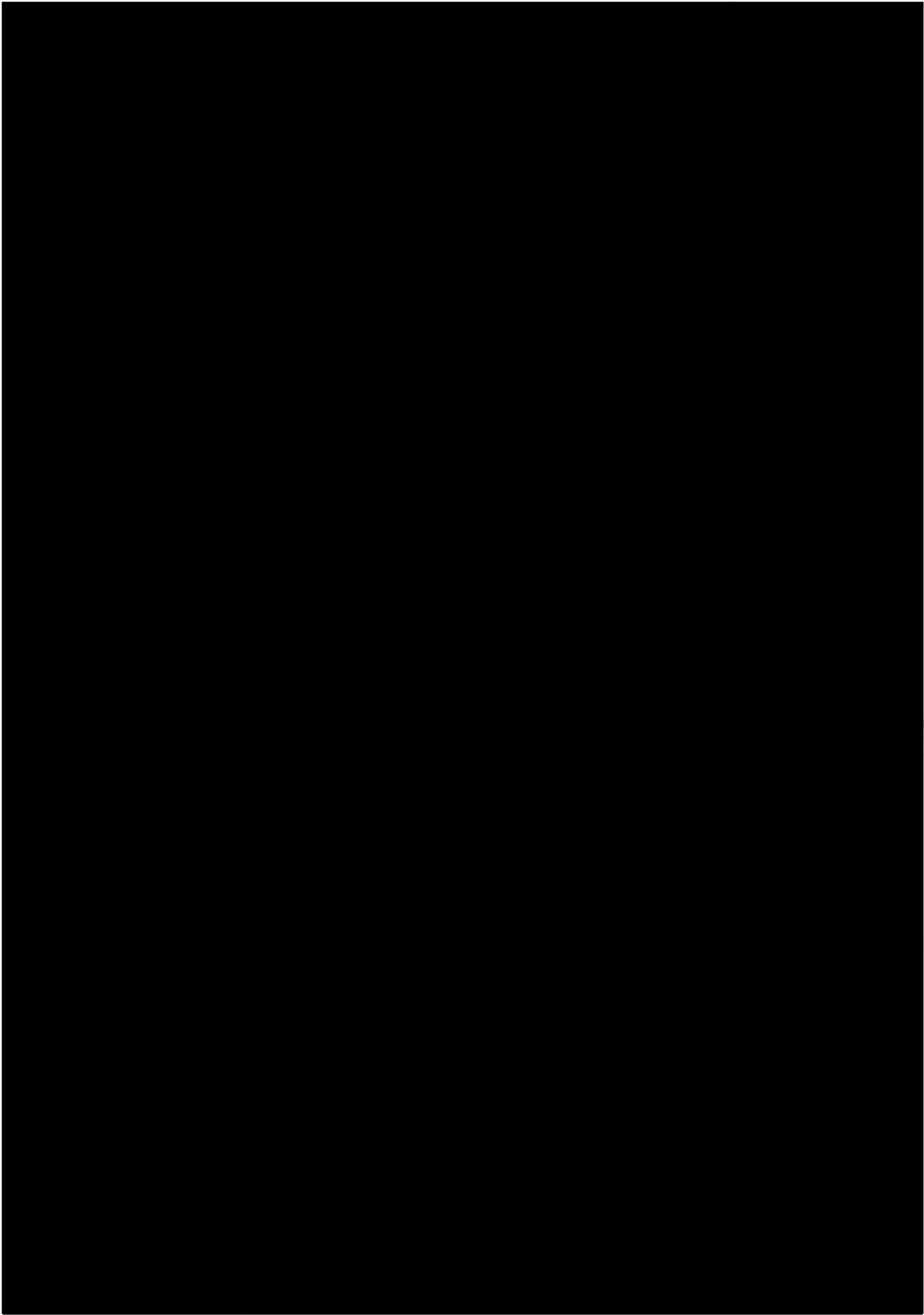

**Dealer Copy**  
**DAVIDSON AUTOMOTIVE GROUP**  
 5871 ROME TABERG ROAD  
 ROME NY, 13440  
 (315) 337-2440

Completed Vehicle Return [Redacted] Buick Encore GX  
 Connexion Generated @ Fri Dec 02 2022 14:11:32 GMT-0500 (Eastern Standard Time)

[Redacted]	Date Out: 11/08/22 7:49am	Repair Order: [Redacted]
	Date In: 12/02/22 2:11pm	Rental Agreement: [Redacted]
	Loan Days: 25 days	Service Adviser: [Redacted]
	Miles Driven: 985	Store: [Redacted]
Security Hold: \$0 ()		

**26813 miles**  
 Current Odometer  
**25828 miles @ checkout**

**40%**  
 Current Fuel Level  
**100% @ checkout**

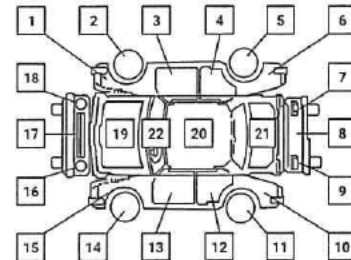

**Condition Report:**

Area	Description
	No reported damage.

**Charges:**

Reason	Description	Charge
	SUBTOTAL	\$0.00

**Total:**

Description	Charges
SUBTOTAL	\$0.00
TOTAL TAX	\$0.00
GRAND TOTAL	\$0.00

*\$1150.00*

Signature:

Date:

*56 days*





# General Motors - Claim Pre-approval Request

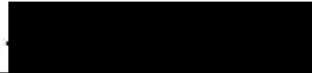

**Request Status:** SUBMITTED

**Create Date:** 10/20/2022

**Approver:** WARRANTY SUPPORT CENTER

**Status Date:** 10/20/2022

**Region:** 40

**Role:** WARRANTY SUPPORT CENTER

### Customer Information

**Name:** [Redacted]  
**Phone:** [Redacted]

### Dealer Information

**BAC:** 115327  
**Dealer:** Davidson Automotive Group  
**Requestor:** STAN BOGACZ

### Vehicle Information

**VIN:** [Redacted]

**Mileage:** 24,912

**Year:** 2017

**Make:** Chevrolet

**Model:** Volt

### Service Event Information

**Reason:** Rentals of 10 or more calendar days - non-field action: Bulletin 07-00-89-037

**Extended Rental Reason:** Parts Backorder

**Job Card #:** [Redacted]

**Open Date:** 08/17/2022

**Close Date:**

**Part #:** 24296900

**Non-GM Parts:** No

**SPAC:** [Redacted]

**TAC #:**

**Labor Op:** 5031010 - Battery Energy Control Module Replacement

**Base Time:** 4.9

**OLH:**

**Total:** 4.90

**Rental Days:** 0

Enter the Total cost of the repair using warranty rates. Customer Participation is the exact dollar amount collected from customer. Dealer participation is dollar amount dealer is contributing (not including repair at warranty rates).

<b>Total Repair Cost:</b>	\$1,295.40
<b>Customer Participation:</b>	\$0.00
<b>Dealer Participation:</b>	\$0.00
<b>Total GM Participation:</b>	\$1,295.40

### Business Reason

Backordered Parts



**Comments**

**Daily Rental Information**

STAN BOGACZ [10/20/2022 12:05:16]: Backordered parts



# WARRANTY REPAIR ORDER

Work Phone		R/O Open Date	R/O Number
Home Phone		08/17/22	
CLINTON, NY		R/O Close Date	Cross Reference #
Year		Mileage In	Mileage Out
2017	CHEVROLET	24912	24915
Model		License Number	Service Advisor
VOLT			DAVID FLINN 1139
Vehicle Identification Number		Delivery Date	In-Service Date
			10/22/16

DESCRIPTION OF SERVICE AND PARTS	COST	AMOUNT
#1 - 10CVZ06: CHECK ENGINE LIGHT CUSTOMER STATES CHECK ENGINE LIGHT ON~CUSTOMER STATES SES LIGHT ON C/S: LIGHT ON AGAIN Cause: VERIFY LIGHT ON IN DASH U2603,U2605,U2618, FOLLOW DOCUMENT #5107213 Tech: 197/4657 0.00hrs @ Part: 24296900:SL-N-MODULE (02210-C) 1 309.68 585.30 Part: 24296900-C:SL-N-MODULE (02210-C) - Cor 1 50.00 50.00 Part: 11517042:SL-N-BOLT (08906-BOPCKT) 4 11.48 21.68 Part: 12378390:N-COOLANT (08800-BOPCKT) 2 16.98 32.10 REMOVE BATTERY AND REPLACE BATTERY ENERGY CONTROL MODULE.REPROGRMAED WARRANTY CLAIM CODE		
Sub Total Parts:	388.14	689.08

#2 - 00CVZ05: MULTIPOINT INSPECT CUSTOMER REQUESTS MULTI POINT INSPECTION MULTI POINT INSPECTION		
--	--	--

ACCOUNT #	LABOR		.00
	PARTS	388.14	689.08
METHOD	SUBLET		.00
	SHOP SUPPLIES		.00
	SALES TAX OR TAX ID		.00
RECEIPT #			.00
		388.14	689.08

SIGNATURE





General Motors - Claim Pre-approval Request

<b>Request Status:</b> APPROVED <b>Approver:</b> DAVID HELLER <b>Region:</b> NORTHEAST		<b>Create Date:</b> 10/20/2022 <b>Status Date:</b> 10/20/2022 <b>Role:</b> DAVID HELLER	
<b>Customer Information</b> Name: [REDACTED] Phone: [REDACTED]		<b>Dealer Information</b> <b>BAC:</b> 115327 <b>Dealer:</b> Davidson Automotive Group <b>Requestor:</b> STAN BOGACZ	
<b>Vehicle Information</b> VIN: [REDACTED] Year: 2017		<b>Mileage:</b> 24,912 <b>Make:</b> Chevrolet <b>Model:</b> Volt	
<b>Service Event Information</b> <b>Reason:</b> Rentals of 10 or more calendar days - non-field action: Bulletin 07-00-89-037 <b>Extended Rental Reason:</b> Parts Backorder <b>Job Card:</b> [REDACTED] <b>Non-GM Parts:</b> No <b>SPAC:</b> [REDACTED] <b>TAC #:</b> <b>Labor Op:</b> 5031010 - Battery Energy Control Module Replacement  <b>Base Time:</b> 4.9 <b>OLH:</b> 0.0 <b>Total:</b> 4.90 <b>GM Rental Days:</b> 56  <b>Total Repair Cost:</b> \$1295.40 <b>Customer Participation:</b> \$0.00 <b>Dealer Participation:</b> \$0.00 <b>Requested GM Participation:</b> \$1295.40			
<b>Business Reason</b> Backordered Parts			
<b>Approver Comments</b> DAVID HELLER [12/5/2022]: Updated Status from SUBMITTED to APPROVED with comment: "Approved final rental request as per timeline provided, time punches, and/or order invoices/SPAC case to support. Please attach a copy of the final approved portal request to the submitted claim within GWM. WSC reserves the right to review." DAVID HELLER [10/21/2022]: Updated Status from SUBMITTED to REWORK with comment: "When repair is done, enter total rental days needed and Job Card Close date. A day by day, detailed time line for rental days requested. SPAC case if applicable. Resubmit the request for further review."			
<b>Daily Rental Activity</b> STAN BOGACZ [12/2/2022]: Repair order opened 8/17/22 Vehicle diagnosed and parts ordered 8/17/22			

Parts Backordered

Customer requested rental 10/7/22

Part arrived 12/1/22

Part installed 12/2/22

Customer returned rental 12/2/22

STAN BOGACZ [10/20/2022]: Backordered parts



# General Motors - Claim Pre-approval Request



**Request Status:** SUBMITTED

**Create Date:** 10/20/2022

**Approver:** WARRANTY SUPPORT CENTER

**Status Date:** 10/21/2022

**Region:** 40

**Role:** WARRANTY SUPPORT CENTER

### Customer Information

**Name:** [Redacted]  
**Phone:** [Redacted]

### Dealer Information

**BAC:** 115327  
**Dealer:** Davidson Automotive Group  
**Requestor:** STAN BOGACZ

### Vehicle Information

**VIN:** [Redacted]      **Mileage:** 24,912  
**Year:** 2017      **Make:** Chevrolet      **Model:** Volt

### Service Event Information

**Reason:** Rentals of 10 or more calendar days - non-field action: Bulletin 07-00-89-037

**Extended Rental Reason:** Parts Backorder

**Job Card #:** [Redacted]      **Open Date:** 08/17/2022      **Close Date:** 12/02/2022

**Part #:** 24296900      **Non-GM Parts:** No      **SPA:** [Redacted]      **TAC #:**

**Labor Op:** 5031010 - Battery Energy Control Module Replacement

**Base Time:** 4.9      **OLH:** 0.0      **Total:** 4.90      **Rental Days:** 56

Enter the Total cost of the repair using warranty rates. Customer Participation is the exact dollar amount collected from customer. Dealer participation is dollar amount dealer is contributing (not including repair at warranty rates).

<b>Total Repair Cost:</b>	\$1,295.40
<b>Customer Participation:</b>	\$0.00
<b>Dealer Participation:</b>	\$0.00
<b>Total GM Participation:</b>	\$1,295.40

### Business Reason

Repair order opened 8/17/22 Vehicle diagnosed and parts ordered 8/17/22 Parts Backordered Customer requested rental 10/7/22 Part arrived 12/1/22 Part installed 12/2/22 Customer returned rental 12/2/22

12/2/22 Customer returned rental 12/2/22

---

**Comments**

STAN BOGACZ [12/02/2022 15:41:56]: [Updating Form] Form has been saved with status SUBMITTED

DAVID HELLER [10/21/2022 08:28:10]: [Updating Status] Updated Status from SUBMITTED to REWORK with comment: "When repair is done, enter total rental days needed and Job Card Close date. A day by day, detailed time line for rental days requested. SPAC case if applicable. Resubmit the request for further review. "

---

**Daily Rental Information**

STAN BOGACZ [12/02/2022 15:41:56]: Repair order opened 8/17/22 Vehicle diagnosed and parts ordered 8/17/22 Parts Backordered Customer requested rental 10/7/22 Part arrived 12/1/22 Part installed 12/2/22 Customer returned rental 12/2/22