

This file represents a consolidation of multiple files sent by the manufacturer. Please use the bookmarks to navigate to each file. (Each bookmark label is the name of the original file.)

Mileage Deductions			
Mileage Deductions for Miles to Dealership			
FROM: ██████████, Sarasota, FL ██████████			
TO: Sunset Cadillac of Sarasota, 2200 Bee Ridge Rd, Sarasota, FL 34239			
Miles to dealer from customer's residence (one way)		3.6 miles	
Round trip miles to dealer		7.2 miles	
7 visits to dealer (7 x 7.2)		Miles to Dealer Total	54.04 miles
Mileage Deduction for Miles dealer used vehicle			
Invoice #	Invoice Date	Mileage	Miles Dealer Put On
1	01/23/20	745 - ██████████	1
2	03/04/20 - 03/06/20	1,546 - 1,547	1
3	03/06/20 - 03/12/20	1,546 - 1,550	4
4	05/26/20 - 05/27/20	2,751	0
5	07/20/20	3,215	0
6	07/29/20 - 07/30/20	4,047 - 4,049	2
7	08/11/20	4,451 - 4,496	45
Total Miles Dealer Used Vehicle			53
Miles to Dealer Total			54.04 miles
Total Miles Dealer Used Vehicle			53 miles
Total miles to deduct			107

Current Mileage = 4,496 - 22 miles at time of purchase = 4,474 miles

4,474 miles - 107 miles deduction = 4,367

4,367/120,000 x \$55,391.44 (Agreed Upon Value) = \$2,015.79 Usage Fee



[Redacted] Sarasota, FL [Redacted] to Sunset
Cadillac Of Sarasota

Drive 3.6 miles, 11 min

Miles to dealer

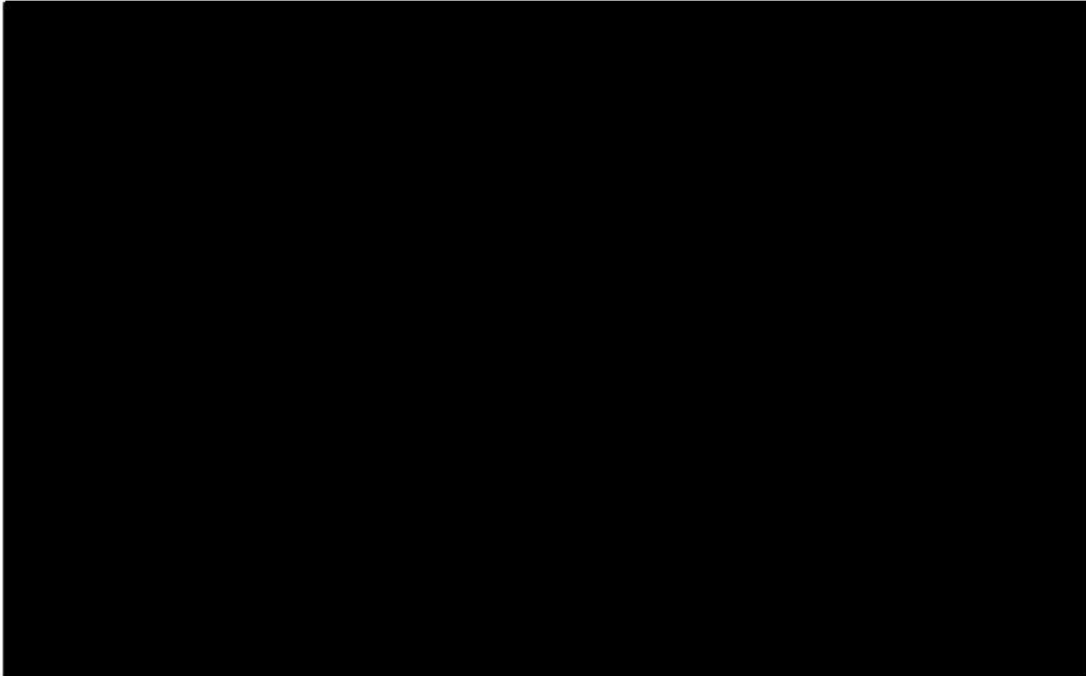
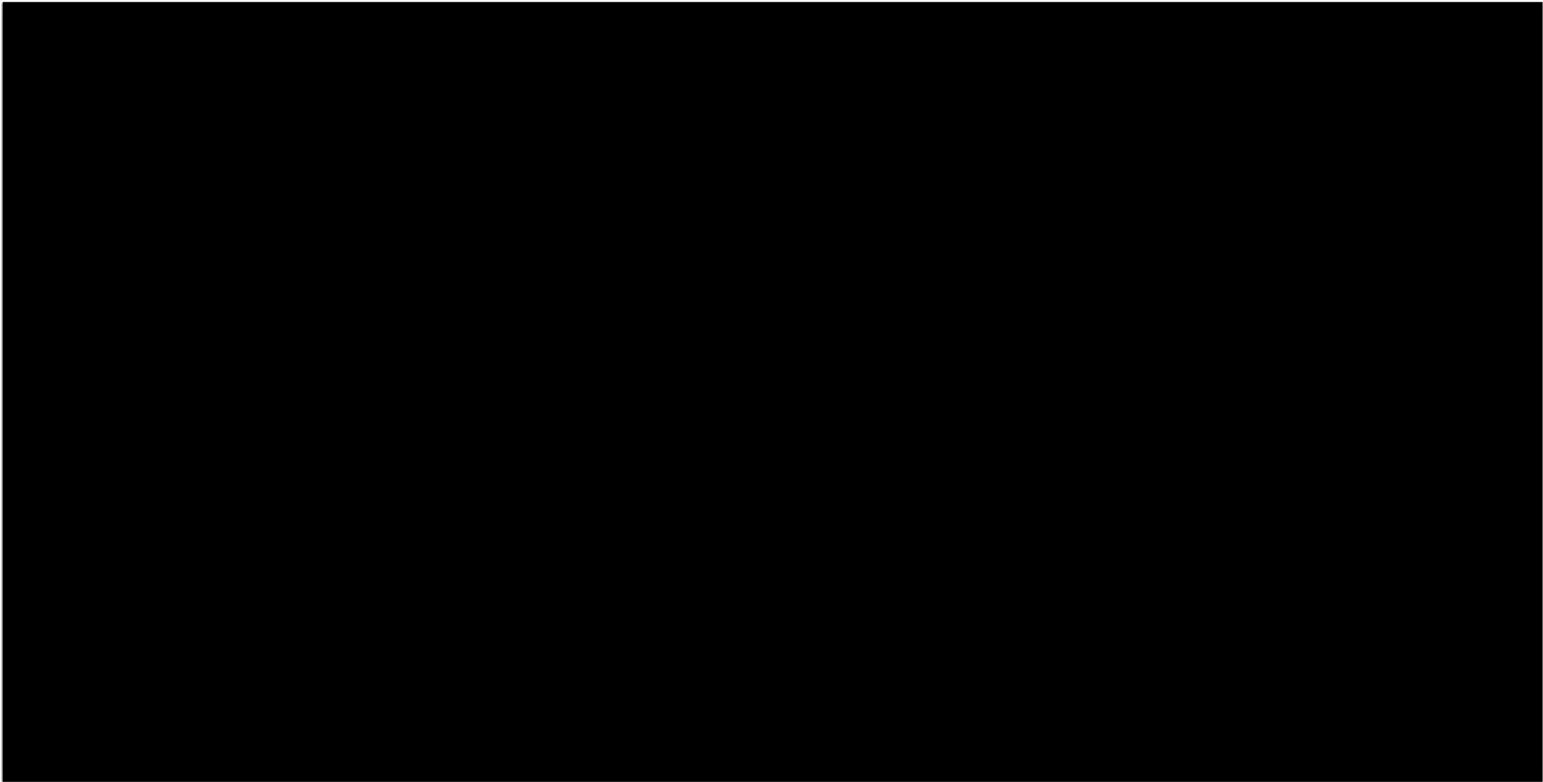

Explore Sunset Cadillac Of Sarasota



Groceries



Hotels



Gas stations



Parking Lots



More



SUNSET CADILLAC OF SARASOTA

A SUNSET AUTOMOTIVE GROUP COMPANY



2200 BEE RIDGE ROAD • SARASOTA, FLORIDA 34239

www.sunsetautogroup.com

STATE OF FLORIDA REGISTRATION: MV-09603

HOURS: 7:30 A.M. - 5:30 P.M. MONDAY-FRIDAY
8:00 A.M. - 3:00 P.M. SATURDAY

CADILLAC SALES

(922-1571)

CADILLAC SERVICE

(923-1849)

CELL: [REDACTED]

CUSTOMER NO. [REDACTED]	ADVISOR RODNEY KIMPTON	790	TAG NO. 4629	INVOICE DATE 01/23/20	INVOICE NO. [REDACTED]
[REDACTED]	LABOR RATE	LICENSE NO.	MILEAGE 745	COLOR CRYST WHITE	STOCK NO. 30081
SARASOTA, FL [REDACTED]	YEAR / MAKE / MODEL 20/CADILLAC/XT6/PREMIUM LUXURY			DELIVERY DATE 12/09/19	DELIVERY MILES 22
[REDACTED]	F.T.E. NO.			P.O. NO.	R.O. DATE 01/23/20
[REDACTED]@YAHOO.COM	RESIDENCE PHONE [REDACTED]			BUSINESS PHONE [REDACTED]	
COMMENTS					

MO: [REDACTED]

LABOR & PARTS	TECH(S)	WARRANTY
J# 1 17CDZ002 ELECTRICAL DIAG C/S: REAR VIEW CAMERA DOES NOT COME ON AT TIMES WHEN REVERSE NG GDS DIAG. B395A-08. REAR VIEW CAMERA PERFORMANCE SIGNAL INVALID. INTERNAL MALFUNCTION IN REAR VIEW CAMERA. CAMERA ORDERED.	:217	
JOB # 1 TOTAL LABOR & PARTS		0.00
J# 2 17CDZ CHASSIS ELECTRICAL CUSTOMER STATES FRONT VIEW CAMERA DOES NOT WORK AT TIMES. GETS RED LINE THRU SMALL PORTION OF SCREEN. TAC CASE 9-5772340204. SEE DOC 5445358. NEW SOFTWARE UPDATE TO RADIO. SPS. INSTALL NEW RADIO PROGRAM. USB FILE TRANSFER UPDATE. USB INSTALL INTO RADIO ALSO.	:217	
JOB # 2 TOTAL LABOR & PARTS		0.00
J# 3 01CDZ *MULTI-POINT INSP PLEASE PERFORM MULTI-POINT INSPECTION THANK YOU FOR YOUR BUSINESS!	:217	
JOB # 3 TOTAL LABOR & PARTS		0.00

COMMENTS
CUSTOMER REQUESTED A LOANER created 2020-01-14 10:22:00am taken by
Rodney Kimpton

TOTALS		
"This charge represents costs and profits to the motor vehicle repair facility for miscellaneous shop supplies or waste disposal." [s.559.904(4)]	TOTAL LABOR...	0.00
"The State of Florida requires a \$1.00 fee to be collected for each new tire sold in the state [s.403.718], and a \$1.50 fee to be collected for each new or remanufactured battery sold in the state [s.403.7185]. *****"	TOTAL PARTS...	0.00
YOU MAY SOON BE RECEIVING A SURVEY FROM GENERAL MOTORS CUSTOMER RELATIONS. THIS SURVEY IS OUR REPORT CARD. IF FOR ANY REASON YOU CANNOT ANSWER THE QUESTIONS AS *COMPLETELY SATISFIED* OR *EXCELLENT SERVICE*, PLEASE CONTACT JIM CARSON AT [REDACTED] 922-1571.	TOTAL SUBLET...	0.00
	TOTAL G.O.G....	0.00
	TOTAL MISC CHG.	0.00
	TOTAL MISC DISC	0.00
	TOTAL TAX.....	0.00
	TOTAL INVOICE \$	0.00

ALL PARTS ARE NEW UNLESS OTHERWISE INDICATED.

I ACKNOWLEDGE AND APPROVE OF ALL WORK PERFORMED, INCLUDING ANY ADDITIONAL WORK THAT MAY HAVE BEEN ADDED ON THE ORIGINAL WORK ORDER. I ACKNOWLEDGE RECEIPT OF A COPY OF THIS INVOICE AND I HAVE REVIEWED THE TERMS AND CONDITIONS ON THE REVERSE SIDE

CUSTOMER SIGNATURE X
The Rep

SUNSET CADILLAC OF SARASOTA

A SUNSET AUTOMOTIVE GROUP COMPANY



2200 BEE RIDGE ROAD • SARASOTA, FLORIDA 34239

www.sunsetautogroup.com

STATE OF FLORIDA REGISTRATION: MV-09603

HOURS: 7:30 A.M. - 5:30 P.M. MONDAY-FRIDAY
8:00 A.M. - 3:00 P.M. SATURDAY

CADILLAC SALES

922-1571

CADILLAC SERVICE

923-1849

CELL: [REDACTED]

CUSTOMER NO	ADVISOR RODNEY KIMPTON	TAG NO. 790 4848	INVOICE DATE 03/06/20	INVOICE NO. CDCS619601
LABOR RATE	LICENSE NO.	MILEAGE 1,546	COLOR CRYST WHITE	STOCK NO. 30081
YEAR / MAKE / MODEL 20/CADILLAC/XT6/PREMIUM LUXURY	DELIVERY DATE 12/09/19	DELIVERY MILES 22	SELLING DEALER NO.	PRODUCTION DATE
F.T.E. NO.	P.O. NO.	R.O. DATE 03/04/20		
RESIDENCE PHONE 941-991-1150	BUSINESS PHONE 941-991-1150	COMMENTS	MO: [REDACTED]	

LABOR & PARTS-----
J# 1 01CDZ *MULTI-POINT INSP TECH(S):217 WARRANTY
 PLEASE PERFORM MULTI-POINT INSPECTION
 THANK YOU FOR YOUR BUSINESS!

PARTS-----QTY---FP-NUMBER-----DESCRIPTION-----UNIT PRICE-----
 JOB # 1 TOTAL PARTS 0.00
 JOB # 1 TOTAL LABOR & PARTS 0.00

J# 2 17CDZ-004 ELECTRICAL DIAG 2 TECH(S):217 WARRANTY
 C/S: REAR VIEW CAMERA DOES NOT COME ON AT TIMES WHEN REVERSI
 NG.
 DUPLICATED AT WRITE UP.
 GDS DIAG SCAN DTC FROM RADIO B395A-72. REAR VIEW CAMERA
 COUNTER INCORRECT AND B395A-3A. REAR VIEW CAMERA STATES
 INCORRECT COMPONENT INSTALLED. OHM OUT CAMERA. CAMERA TEST
 INDICATE OPEN. 8 OHMS. INTERNAL MALFUNCTION IN CAMERA.
 REPLACED REAR VIEW CAMERA. NO MORE CAMERA DTCS FROM RADIO.
 GDS DIAG. SCAN DTCS FROM VIDEO PROCESSING CONTROL MODULE
 B395A-08, B399B-05. REAR VIEW CAMERA INVALID PERFORMANCE
 SIGNAL AND REAR VIEW SUPPLY VOLTAGE OPEN. NO VOLTAGE TO
 CAMERA. INSTALL EL-52552 COAX FAKRA CABLE ADAPTER TEST KIT
 TO VIDEO PROCESSING CONTROL MODULE. TEST THE X3 VIDEO
 CONNECTOR AT PROCESSOR, A TERMINAL 2-RD ZERO VOLTS. INTERNAL
 SHORT IN THE VIDEO PROCESSING CONTROL MODULE.
 REPLACED AND PROGRAMMED VIDEO PROCESSING CONTROL MODULE.
 ROAD TEST.

PARTS-----QTY---FP-NUMBER-----DESCRIPTION-----UNIT PRICE-----
 JOB # 2 1 84483315 CAMERA 9.715 N WARRANTY
 JOB # 2 1 84754345 MODULE 9.680 N WARRANTY
 JOB # 2 TOTAL PARTS 0.00
 JOB # 2 TOTAL LABOR & PARTS 0.00

COMMENTS-----
 CUSTOMER REQUESTED A LOANER created 2020-02-25 08:20:00am taken by
 Rodney Kimpton

ALL PARTS ARE NEW UNLESS OTHERWISE INDICATED.

I ACKNOWLEDGE AND APPROVE OF ALL WORK PERFORMED, INCLUDING ANY ADDITIONAL WORK THAT MAY HAVE BEEN ADDED ON THE ORIGINAL WORK ORDER. I ACKNOWLEDGE RECEIPT OF A COPY OF THIS INVOICE AND I HAVE REVIEWED THE TERMS AND CONDITIONS LISTED ON THE REVERSE SIDE OF THIS PAGE.

CUSTOMER SIGNATURE X _____

The Reynolds and Reynolds Company ERAINTIVE SF611758 Q (03/17)

SUNSET CADILLAC OF SARASOTA

A SUNSET AUTOMOTIVE GROUP COMPANY



2200 BEE RIDGE ROAD • SARASOTA, FLORIDA 34239

www.sunsetautogroup.com

STATE OF FLORIDA REGISTRATION: MV-09603

HOURS: 7:30 A.M. - 5:30 P.M. MONDAY-FRIDAY
8:00 A.M. - 3:00 P.M. SATURDAY

CADILLAC SALES

922-1571

CADILLAC SERVICE

923-1849

CELL: [REDACTED]

01011RDCS019801

CUSTOMER NO. [REDACTED]	ADVISOR RODNEY KIMPTON	TAG NO. 790 4848	INVOICE DATE 03/06/20	INVOICE NO. [REDACTED]
[REDACTED]	LABOR RATE	LICENSE NO.	MILEAGE 1,546	COLOR CRYST WHITE
[REDACTED]	YEAR / MAKE / MODEL 20/CADILLAC/XT6/PREMIUM LUXURY	VEHICLE I.D. NO. [REDACTED]	DELIVERY DATE 12/09/19	STOCK NO. 30081
SARASOTA, FL	F.T.E. NO.	P.O. NO.	SELLING DEALER NO.	DELIVERY MILES 22
[REDACTED] YAHOO.COM	COMMENTS		R.O. DATE 03/04/20	PRODUCTION DATE
RESIDENCE PHONE [REDACTED]	BUSINESS PHONE [REDACTED]	MO: [REDACTED]		

TOTALS-----

"This charge represents costs and profits to the motor vehicle repair facility for miscellaneous shop supplies or waste disposal." [s.559.904(4)]

"The State of Florida requires a \$1.00 fee to be collected for each new tire sold in the state [s.403.718], and a \$1.50 fee to be collected for each new or remanufactured battery sold in the state [s.403.7185].*****

YOU MAY SOON BE RECEIVING A SURVEY FROM GENERAL MOTORS CUSTOMER RELATIONS. THIS SURVEY IS OUR REPORT CARD. IF FOR ANY REASON YOU CANNOT ANSWER THE QUESTIONS AS *COMPLETELY SATISFIED* OR *EXCELLENT SERVICE*, PLEASE CONTACT JIM CARSON AT [REDACTED] 922-1571.

TOTAL LABOR....	0.00
TOTAL PARTS....	0.00
TOTAL SUBLET...	0.00
TOTAL G.O.G....	0.00
TOTAL MISC CHG.	0.00
TOTAL MISC DISC	0.00
TOTAL TAX.....	0.00
TOTAL INVOICE \$	0.00

ALL PARTS ARE NEW UNLESS OTHERWISE INDICATED.

I ACKNOWLEDGE AND APPROVE OF ALL WORK PERFORMED, INCLUDING ANY ADDITIONAL WORK THAT MAY HAVE BEEN ADDED ON THE ORIGINAL WORK ORDER. I ACKNOWLEDGE RECEIPT OF A COPY OF THIS INVOICE. TERMS AND CONDITIONS ARE ON REVERSE SIDE.

CUSTOMER SIGNATURE [REDACTED]

SUNSET CADILLAC OF SARASOTA

A SUNSET AUTOMOTIVE GROUP COMPANY



2200 BEE RIDGE ROAD • SARASOTA, FLORIDA 34239

www.sunsetautogroup.com

STATE OF FLORIDA REGISTRATION: MV-09603

HOURS: 7:30 A.M. - 5:30 P.M. MONDAY-FRIDAY
8:00 A.M. - 3:00 P.M. SATURDAY

CADILLAC SALES

922-1571

CADILLAC SERVICE

923-1849



0101ICDCS619729

CELL: [REDACTED]

CUSTOMER NO. [REDACTED]	ADVISOR RODNEY KIMPTON	790	TAG NO. 4869	INVOICE DATE 03/12/20	INVOICE NO. CDCS619729
[REDACTED]	LABOR RATE	LICENSE NO.	MILEAGE 1,546	COLOR CRYST WHITE	STOCK NO. 30081
SARASOTA, FL	YEAR / MAKE / MODEL 20/CADILLAC/XT6/PREMIUM LUXURY			DELIVERY DATE 12/09/19	DELIVERY MILES 22
[REDACTED]@AHO.COM	[REDACTED]			CALLING DEALER NO.	PRODUCTION DATE
RESIDENCE PHONE [REDACTED]	BUSINESS PHONE [REDACTED]	F.T.E. NO.	P.O. NO.	R.O. DATE 03/06/20	
COMMENTS					MO: 1550

LABOR & PARTS
J# 1 17CDZ CHASSIS ELECTRICAL TECH(S):217 WARRANTY

CUSTOMER STATES REAR VIEW CAMERA IS NOT WORKING.
GETTING RED SYMBOL ON SCREEN.
GDS DIAG RADIO DTC B395A-08, B395A-3A AND B395A-72. TAC
CASE 9-5851883116. DIAG WITH THE EL-52552 VIDEO TEST KIT.
VPCM TEST GOOD. REAR CAMERA TEST GOOD. ADVISED TO REPLACE
RADIO AND PROGRAM SPS AND PROGRAM USB PORTION OF RADIO.
REPLACED RADIO AND PROGRAMMED SPS. PROGRAM USB PORTION OF
RADIO. TESTED SEVERAL TIMES.

JOB # 1 TOTAL LABOR & PARTS 0.00

COMMENTS
LOANER

TOTALS

TOTAL LABOR...	0.00
TOTAL PARTS...	0.00
TOTAL SUBLET...	0.00
TOTAL G.O.G....	0.00
TOTAL MISC CHG.	0.00
TOTAL MISC DISC	0.00
TOTAL TAX.....	0.00
TOTAL INVOICE \$	0.00

"This charge represents costs and profits to the motor vehicle repair facility for miscellaneous shop supplies or waste disposal." [s.559.904(4)]
"The State of Florida requires a \$1.00 fee to be collected for each new tire sold in the state [s.403.718], and a \$1.50 fee to be collected for each new or remanufactured battery sold in the state [s.403.718]."*****
YOU MAY SOON BE RECEIVING A SURVEY FROM GENERAL MOTORS CUSTOMER RELATIONS. THIS SURVEY IS OUR REPORT CARD. IF FOR ANY REASON YOU CANNOT ANSWER THE QUESTIONS AS *COMPLETELY SATISFIED* OR *EXCELLENT SERVICE*, PLEASE CONTACT JIM CARSON AT [REDACTED] 922-1571.

ALL PARTS ARE NEW UNLESS OTHERWISE INDICATED.

I ACKNOWLEDGE AND APPROVE OF ALL WORK PERFORMED, INCLUDING ANY ADDITIONAL WORK THAT MAY HAVE BEEN ADDED ON THE ORIGINAL WORK ORDER. I ACKNOWLEDGE RECEIPT OF A COPY OF THIS INVOICE AND I HAVE REVIEWED THE TERMS AND CONDITIONS LISTED ON THE REVERSE.

CUSTOMER SIGNATURE [REDACTED]

SUNSET CADILLAC
OF SARASOTA
A SUNSET AUTOMOTIVE GROUP COMPANY



2200 BEE RIDGE ROAD • SARASOTA, FLORIDA 34239
www.sunsetautogroup.com

STATE OF FLORIDA REGISTRATION: MV-09603

HOURS: 7:30 A.M. - 5:30 P.M. MONDAY-FRIDAY
8:00 A.M. - 3:00 P.M. SATURDAY

CADILLAC SALES

922-1571

CADILLAC SERVICE

923-1849

CELL: [REDACTED]

CUSTOMER NO [REDACTED]	ADVISOR RODNEY KIMPTON	790	TAG NO. 7164	INVOICE DATE 05/27/20	INVOICE NO [REDACTED]
[REDACTED] SARASOTA, FL [REDACTED] [REDACTED]@AHO.COM	LABOR RATE	LICENSE NO	MILEAGE 2,751	COLOR CRYST WHITE	STOCK NO 30081
	YEAR / MAKE / MODEL 20/CADILLAC/XT6/PREMIUM LUXURY			DELIVERY DATE 12/09/19	DELIVERY MILES 22
RESIDENCE PHONE [REDACTED]	BUSINESS PHONE [REDACTED]	VEHICLE NO [REDACTED]	P.C. NO. [REDACTED]	SELLING DEALER NO.	PRODUCTION DATE
COMMENTS				R.O. DATE 05/26/20	
					MO: 2751

LABOR & PARTS

J# 1 17CDZ-004 ELECTRICAL DIAG 2 TECH(S):217 WARRANTY
CUSTOMER STATES WHEN PUTTING VEHICLE IN REVERSE SCREEN IS BLANK. SHOWS SYMBOL WITH LINE THRU CAMERA. NEEDS VIDEO PROCESSOR PER TAC CASE 9-5975813938. PART ORDERED. PART IS ON BACK ORDER WITH NO ETA AT THIS TIME.
JOB # 1 TOTAL LABOR & PARTS 0.00

J# 2 17CDZ002 ELECTRICAL DIAG TECH(S):217 WARRANTY
CUSTOMER STATES WHEN IPHONE 10 IS TETHERED TO VEHICLE VIA APPLY CAR PLAY SCREEN WILL NOT SHOW GPS/ NAV. USING FACTORY APPLE CORD. DISCONNECTS FROM VEHICLE WHILE DRIVING. OWNER HAS TO UNPLUG CORD AND REPLUG TO GET SYSTEM TO OPERATE AGAIN. SEE JOB 1.
JOB # 2 TOTAL LABOR & PARTS 0.00

J# 3 01CDZ *MULTI-POINT INSP TECH(S):217 WARRANTY
PLEASE PERFORM MULTI-POINT INSPECTION
SEE ATTACHED SHEET
THANK YOU FOR YOUR BUSINESS!
JOB # 3 TOTAL LABOR & PARTS 0.00

COMMENTS
CUSTOMER REQUESTED A LOANER created 2020-05-18 12:48:00pm taken by Rodney Kimpton

TOTALS

"This charge represents costs and profits to the motor vehicle repair facility for miscellaneous shop supplies or waste disposal."[s.559.904(4)]	TOTAL LABOR....	0.00
"The State of Florida requires a \$1.00 fee to be collected for each new tire sold in the state [s.403.718],and a \$1.50 fee to be collected for each new or remanufactured battery sold in the state [s.403.7185]."	TOTAL PARTS....	0.00
*****	TOTAL SUBLET...	0.00
YOU MAY SOON BE RECEIVING A SURVEY FROM GENERAL MOTORS CUSTOMER RELATIONS. THIS SURVEY IS OUR REPORT CARD. IF FOR ANY REASON YOU CANNOT ANSWER THE QUESTIONS AS *COMPLETELY SATISFIED* OR *EXCELLENT SERVICE*, PLEASE CONTACT JIM CARSON AT [REDACTED] 922-1571.	TOTAL G.O.G....	0.00
	TOTAL MISC CHG.	0.00
	TOTAL MISC DISC	0.00
	TOTAL TAX.....	0.00
	TOTAL INVOICE \$	0.00

ALL PARTS ARE NEW UNLESS OTHERWISE INDICATED.

I ACKNOWLEDGE AND APPROVE OF ALL WORK PERFORMED, INCLUDING ANY ADDITIONAL WORK THAT MAY HAVE BEEN ADDED ON THE ORIGINAL WORK ORDER. I ACKNOWLEDGE RECEIPT OF A COPY OF THIS INVOICE AND I HAVE REVIEWED THE TERMS AND CONDITIONS ON THE REVERSE SIDE

CUSTOMER SIGNATURE X [REDACTED]

SUNSET CADILLAC
OF SARASOTA
A SUNSET AUTOMOTIVE GROUP COMPANY



2200 BEE RIDGE ROAD • SARASOTA, FLORIDA 34239

www.sunsetautogroup.com

STATE OF FLORIDA REGISTRATION: MV-09603

HOURS: 7:30 A.M. - 5:30 P.M. MONDAY-FRIDAY
8:00 A.M. - 3:00 P.M. SATURDAY

CADILLAC SALES

922-1571

CADILLAC SERVICE

923-1849

CELL: [REDACTED]

CUSTOMER NO [REDACTED]	ADVISOR JIM CARSON	TAG NO 813	739	INVOICE DATE 07/21/20	[REDACTED]
[REDACTED]	LABOR RATE	LICENSE NO	MILEAGE 3,215	COLOR CRYST WHITE	STOCK NO. 30081
SARASOTA, FL	YEAR / MAKE / MODEL 20/CADILLAC/XT6/PREMIUM LUXURY			DELIVERY DATE 12/09/19	DELIVERY MILES 22
[REDACTED]	VEHICLE I.D. NO [REDACTED]			SELLING DEALER NO	PRODUCTION DATE
[REDACTED]@YAHOO.COM	F.T.E. NO	P.O. NO		R.O. DATE 07/21/20	
RESIDENCE PHONE [REDACTED]	BUSINESS PHONE [REDACTED]	COMMENTS			

LABOR & PARTS-----
J# 1 81CDZZ-MICRO MICRO FIBER CLOTH TECH(S):813 2.00
CUSTOMER REQUEST NEW MICRO FIBER CLOTH
SERVICE
GAVE CUSTOMER NEW MICRO FIBER CLOTH FOR CUE SCREEN

PARTS-----	QTY----	FP-NUMBER-----	DESCRIPTION-----	UNIT PRICE-	
JOB # 1	1	23356336	FABRIC 8.800 N	6.00	6.00
				JOB # 1 TOTAL PARTS	6.00
				JOB # 1 TOTAL LABOR & PARTS	8.00

MISC-----	CODE-----	DESCRIPTION--	CONTROL NO-----	
JOB # A	SS	SHOP SUPPLIES		0.80
TOTAL - MISC				0.80

COMMENTS-----
ASAP

TOTALS-----

"This charge represents costs and profits to the motor vehicle repair facility for miscellaneous shop supplies or waste disposal." [s.559.904(4)]	TOTAL LABOR....	2.00
"The State of Florida requires a \$1.00 fee to be collected for each new tire sold in the state [s.403.718], and a \$1.50 fee to be collected for each new or remanufactured battery sold in the state [s.403.7185]."	TOTAL PARTS....	6.00
*****	TOTAL SUBLET...	0.00
YOU MAY SOON BE RECEIVING A SURVEY FROM GENERAL MOTORS CUSTOMER RELATIONS. THIS SURVEY IS OUR REPORT CARD. IF FOR ANY REASON YOU CANNOT ANSWER THE QUESTIONS AS *COMPLETELY SATISFIED* OR *EXCELLENT SERVICE*, PLEASE CONTACT JIM CARSON AT [REDACTED] 922-1571.	TOTAL G.O.G....	0.00
	TOTAL MISC CHG.	0.80
	TOTAL MISC DISC	0.00
	TOTAL TAX.....	0.62
	TOTAL INVOICE \$	9.42

METHOD OF PAYMENT ()CASH ()CHECK ()M/C-VISA ()DISC ()AM EXP

CUSTOMER SIGNATURE _____
***** DUPLICATE INVOICE *****

ALL PARTS ARE NEW UNLESS OTHERWISE INDICATED.

I ACKNOWLEDGE AND APPROVE OF ALL WORK PERFORMED, INCLUDING ANY ADDITIONAL WORK THAT MAY HAVE BEEN ADDED ON THE ORIGINAL WORK ORDER. I ACKNOWLEDGE RECEIPT OF A COPY OF THIS INVOICE AND I HAVE REVIEWED THE TERMS AND CONDITIONS LISTED ON THE REVERSE SIDE OF THIS PAGE.

CUSTOMER SIGNATURE X _____

SUNSET CADILLAC OF SARASOTA

A SUNSET AUTOMOTIVE GROUP COMPANY



2200 BEE RIDGE ROAD • SARASOTA, FLORIDA 34239

www.sunsetautogroup.com

STATE OF FLORIDA REGISTRATION: MV-09603

HOURS: 7:30 A.M. - 5:30 P.M. MONDAY-FRIDAY

8:00 A.M. - 3:00 P.M. SATURDAY

CADILLAC SALES

(941) 922-1571

CADILLAC SERVICE

923-1849

CELL: [REDACTED]

CUSTOMER NO. [REDACTED]	ADVISOR RODNEY KIMPTON	790	TAG NO. 7434	INVOICE DATE 07/30/20	INVOICE NO. [REDACTED]
[REDACTED]	LABOR RATE	LICENSE NO.	MILEAGE 4,047	COLOR CRYST WHITE	STOCK NO. 30081
SARASOTA, FL [REDACTED]	YEAR / MAKE / MODEL 20/CADILLAC/XT6/PREMIUM LUXURY			DELIVERY DATE 12/09/19	DELIVERY MILES 22
[REDACTED]	[REDACTED]			SELLING DEALER NO.	PRODUCTION DATE
[REDACTED] AHOO.COM	F.T.E. NO.	P.O. NO.	R.O. DATE 07/29/20		
RESIDENCE PHONE [REDACTED]	BUSINESS PHONE [REDACTED]	COMMENTS			

MO: [REDACTED]

LABOR & PARTS

J# 1 01CDZ2262 PREM CARE OIL CHANGE TECH(S):217 WARRANTY
 CADILLAC PREMIUM CARE OIL CHANGE
 OIL CHANGE NEEDED DUE TO TIME AND OR MILEAGE INTERVAL
 CADILLAC PREMIUM CARE OIL CHANGE

PARTS	QTY	FP-NUMBER	DESCRIPTION	UNIT PRICE	WARRANTY
JOB # 1	1	12690385	FILTER 1.836 Y		WARRANTY
JOB # 1	6	19420080	OIL 8.800 N		WARRANTY
JOB # 1 TOTAL PARTS					0.00
JOB # 1 TOTAL LABOR & PARTS					0.00

J# 2 17CDZ001 RADIO TECH(S):217 WARRANTY
 C/S: PAY ONE OF OWNERS LEASE PAYMENT FOR LOSS OF BACK UP CAM
 ERA FEATURE.
 OWNER PROVIDING LEASE PAYMENT INFO.

PARTS	QTY	FP-NUMBER	DESCRIPTION	UNIT PRICE	WARRANTY
JOB # 2 TOTAL PARTS					0.00
JOB # 2 TOTAL LABOR & PARTS					0.00

J# 3 17CDZ-004 ELECTRICAL DIAG 2 TECH(S):217 WARRANTY
 C/S: WHEN PUTTING VEHICLE IS REVERSE SCREEN IS BLANK. SHOWS
 SYMBOL WITH LINE THRU CAMERA.
 DTC B395A-08 , B395A-3A. TAC CASE NUMBER 9-5851883116.
 ADVISED TO REPLACE VIDEO PROCESS MODULE.
 REPLACED VPMAND PROGRAMMED. TESTED EIGHT TIMES
 TODAY.

PARTS	QTY	FP-NUMBER	DESCRIPTION	UNIT PRICE	WARRANTY
JOB # 3	1	84754345	MODULE 9.680 N		WARRANTY
JOB # 3 TOTAL PARTS					0.00
JOB # 3 TOTAL LABOR & PARTS					0.00

J# 4 01CDZ2263 CAD PREMIUM CARE T/R TECH(S):217 WARRANTY
 CADILLAC PREMIUM CARE TIRE ROTATION
 DUE FOR ROTATION
 PERFORMED TIRE ROTATION AND REST TPM SENSORS

PARTS	QTY	FP-NUMBER	DESCRIPTION	UNIT PRICE	WARRANTY
JOB # 4 TOTAL PARTS					0.00
JOB # 4 TOTAL LABOR & PARTS					0.00

J# 5 01CDZ *MULTI-POINT INSP TECH(S):217 WARRANTY
 PLEASE PERFORM MULTI-POINT INSPECTION
 THANK YOU FOR YOUR BUSINESS!

PARTS	QTY	FP-NUMBER	DESCRIPTION	UNIT PRICE	WARRANTY
JOB # 5 TOTAL PARTS					0.00

ALL PARTS ARE NEW UNLESS OTHERWISE INDICATED.

I ACKNOWLEDGE AND APPROVE OF ALL WORK PERFORMED, INCLUDING ANY ADDITIONAL WORK THAT MAY HAVE BEEN ADDED ON THE ORIGINAL WORK ORDER. I ACKNOWLEDGE RECEIPT OF A COPY OF THIS INVOICE AND I HAVE REVIEWED THE TERMS AND CONDITIONS LISTED ON THE REVERSE SIDE OF THIS PAGE.

CUSTOMER SIGNATURE X _____

SUNSET CADILLAC
OF SARASOTA
 A SUNSET AUTOMOTIVE GROUP COMPANY



2200 BEE RIDGE ROAD • SARASOTA, FLORIDA 34239

www.sunsetautogroup.com

STATE OF FLORIDA REGISTRATION: MV-09603

HOURS: 7:30 A.M. - 5:30 P.M. MONDAY-FRIDAY
 8:00 A.M. - 3:00 P.M. SATURDAY

CADILLAC SALES
 (941) 922-1571

CADILLAC SERVICE
 923-1849

CELL: [REDACTED]

CUSTOMER NO. [REDACTED]	ADVISOR RODNEY KIMPTON	790	TAG NO 7434	INVOICE DATE 07/30/20	INVOICE NO. [REDACTED]
[REDACTED]	LABOR RATE	LICENSE NO.	MILEAGE 4,047	COLOR CRYST WHITE	STOCK NO. 30081
SARASOTA, FL [REDACTED]	YEAR / MAKE / MODEL 20/CADILLAC/XT6/PREMIUM LUXURY			DELIVERY DATE 12/09/19	DELIVERY MILES 22
[REDACTED]	VEHICLE NO. [REDACTED]			SELLING DEALER NO.	PRODUCTION DATE
[REDACTED] YAHOO.COM	F.T.E. NO.	P.O. NO.	R.O. DATE 07/29/20		
RESIDENCE PHONE [REDACTED]	BUSINESS PHONE [REDACTED]	COMMENTS			

JOB # 5 TOTAL LABOR & PARTS 0.00

COMMENTS-----
 CUSTOMER REQUESTED A LOANER created 2020-07-23 11:14:00am taken by
 Rodney Kimpton

TOTALS-----

"This charge represents costs and profits to the motor vehicle repair facility for miscellaneous shop supplies or waste disposal." [s.559.904(4)]	TOTAL LABOR....	0.00
"The State of Florida requires a \$1.00 fee to be collected for each new tire sold in the state [s.403.718], and a \$1.50 fee to be collected for each new or remanufactured battery sold in the state [s.403.718].*****"	TOTAL PARTS....	0.00
YOU MAY SOON BE RECEIVING A SURVEY FROM GENERAL MOTORS CUSTOMER RELATIONS. THIS SURVEY IS OUR REPORT CARD. IF FOR ANY REASON YOU CANNOT ANSWER THE QUESTIONS AS *COMPLETELY SATISFIED* OR *EXCELLENT SERVICE*, PLEASE CONTACT JIM CARSON AT [REDACTED] 922-1571.	TOTAL SUBLET...	0.00
	TOTAL G.O.G....	0.00
	TOTAL MISC CHG.	0.00
	TOTAL MISC DISC	0.00
	TOTAL TAX.....	0.00
	TOTAL INVOICE \$	0.00

ALL PARTS ARE NEW UNLESS OTHERWISE INDICATED.

I ACKNOWLEDGE AND APPROVE OF ALL WORK PERFORMED, INCLUDING ANY ADDITIONAL WORK THAT MAY HAVE BEEN ADDED ON THE ORIGINAL WORK ORDER. I ACKNOWLEDGE RECEIPT OF A COPY OF THIS INVOICE. TERMS AND CONDITIONS ARE ON REVERSE.

CUSTOMER SIGNATURE [REDACTED]



SUNSET CADILLAC OF SARASOTA
INFINITI OF SARASOTA
VOLVO CARS SARASOTA
2200 Bee Ridge Road • SARASOTA, FLORIDA 34239
Telephone: (941) 922-1571



PAY **SIX HUNDRED SIXTY EIGHT DOLLARS AND 12/100**

DATE	AMOUNT
07/30/20	\$668.12

TO THE
ORDER
OF



SUNSET CADILLAC OF SARASOTA INFINITI OF SARASOTA VOLVO CARS SARASOTA
VOID AFTER 90 DAYS



SUNTRUST BANK

AUTHORIZED SIGNATURE



NAME	NUMBER	DATE
[Redacted]	[Redacted]	07/30/20

DATE	INV. NO.	AMOUNT	DATE	INV. NO.	AMOUNT
07/30/20	REIMB-LEASE	668.12			

Dear Customer,

In an effort to prevent fraud and keep our costs low, we are on a fraud prevention service with Suntrust Bank called Positive Pay. Because of this service, this check may not be cashed at any Suntrust Bank branch until the next business day. However, you can deposit the check at your financial institution without delay.

We sincerely appreciate your cooperation.

REMITTANCE ADVICE
DETACH AND RETAIN

SUNSET CADILLAC OF SARASOTA
INFINITI OF SARASOTA
VOLVO CARS SARASOTA
Sarasota, Florida 34239

CHECK NO. [Redacted]	NET AMOUNT	\$668.12
-------------------------	---------------	----------

623784

023704

SUNSET CADILLAC OF SARASOTA

A SUNSET AUTOMOTIVE GROUP COMPANY

2200 Bee Ridge Road • SARASOTA, FLORIDA 34239
Telephone: 922-1571
923-1849



www.sunsetautogroup.com
State of Florida Registration: MV-09603

217

STATE REG# MV9603

161618 903310

ALL PARTS ARE NEW UNLESS OTHERWISE INDICATED.
SEE BACK FOR ADDITIONAL CUSTOMER INFORMATION REGARDING REPAIRS

RECOMMENDED SERVICES

OPERATION	OPERATION DESCRIPTION	MO / MI	TOTAL
03CDZZ28	ROTATE AND BALANCE	MO	
98CDZ10CDZZ05	21000 MILE SERVICE	MI	
10CDZZ13	BG DIFF FLUSH	MI	
98CDZ10CDZZ25	EMISSION SERVICE	MI	
10CDZZ15	BG 4WD SERVICE	MI	
98CDZ88CDZZ01	LUBE OIL AND FILTER	MI	
98CDZ95CDZZ01	LUBE OIL AND FILTER	MI	
98CDZ95CDZZ03	ROTATE AND BALANCE	MI	
98CDZ95CDZZ07	TIRE ROTATION	MO	
98CDZ95CDZZ08	BALANCE WHEELS/TIRES	MO	

PLEASE READ CAREFULLY, CHECK ONE OF THE STATEMENTS BELOW, AND SIGN: I UNDERSTAND THAT UNDER STATE LAW, I AM ENTITLED TO A WRITTEN ESTIMATE, IF MY FINAL BILL WILL EXCEED \$100.00.

- I REQUEST A WRITTEN ESTIMATE.
- I DO NOT REQUEST A WRITTEN ESTIMATE AS LONG AS THE REPAIR COSTS DO NOT EXCEED \$_____. THE SHOP MAY NOT EXCEED THIS AMOUNT WITHOUT MY WRITTEN OR ORAL APPROVAL.
- I DO NOT REQUEST A WRITTEN ESTIMATE.

SIGNATURE DATE 8/11/20

DATE	REPAIR ORDER	MILEAGE	ADVISOR	TECHNICIAN	TYPE	OPERATION	OPERATION DESCRIPTION
07/29/20	623402	4047	790	217	W	01CDZ2262	PREM CARE OIL CHANGE
				217	W	17CDZ001	RADIO
				217	W	17CDZ-004	ELECTRICAL DIAG 2
				217	W	01CDZ2263	CAD PREMIUM CARE T/R
				217	W	01CDZ	*MULTI-POINT INSP
07/21/20	623185	3215	813	813	C	81CDZZ-MICRO	MICRO FIBER CLOTH

SERVICE SALESPERSON NO. 918 ALEJANDRO A RODRIGUE

VEHICLE ID NO.	YEAR / MAKE / MODEL	STOCK NO.	LICENSE NO.	R. O. NO.
[REDACTED]	20/CADILLAC/XT6/PREMIUM LUXURY	30081		623784
CUSTOMER NO.	SERVICE CONTRACT	DELIVERY DATE	DELIVERY MILES	SELLING DEALER NO.
[REDACTED]	[REDACTED]	12/09/19	22	R. O. DATE
COLOR	CONTRACT NO.	EXPIRATION DATE	EXPIRATION MILES	TAG NO.
SARASOTA, FL	CRYST WHITE TRI/C			[REDACTED]
YAHOO.COM	TURBO M/MC AIR COND. P. S. TRANS MILEAGE	ADVISOR NO.	PRODUCTION DATE	
	N CDZZ Y Y A 4,451	790		

RESIDENCE OR CELL PHONE	TIME RECEIVED	AUTHORIZATION: I, THE CUSTOMER, HEREBY AUTHORIZE THE REPAIR WORK TO BE DONE, ALONG WITH THE USE AND APPLICATION OF ANY NECESSARY MATERIALS, AND AGREE THAT YOU, THE REPAIR SHOP, ARE NOT RESPONSIBLE FOR LOSS OR DAMAGE TO ANY OTHER CAUSE BEYOND YOUR CONTROL OR FOR ANY DELAYS CAUSED BY UNAVAILABILITY OF PARTS OR DELAYS IN PARTS SHIPMENTS BY THE SUPPLIER OR TRANSPORTER. THIS REPAIR SHOP IS ALSO NOT RESPONSIBLE FOR THEFT OF THE VEHICLE OR THEFT OF ANY ARTICLES STOLEN FROM INSIDE OR ON THE VEHICLE OR ANY DAMAGE CAUSED BY FIRE OR ANY ACTS OF NATURE. I HEREBY GRANT YOU AND/OR YOUR EMPLOYEES PERMISSION TO OPERATE THE VEHICLE ON STREETS, HIGHWAYS, OR ELSEWHERE, FOR THE PURPOSE OF TESTING AND/OR INSPECTION. AN EXPRESS MECHANIC'S LIEN IS ACKNOWLEDGED ON THIS VEHICLE TO SECURE THE AMOUNT OF THESE REPAIRS. ALL PARTS ARE NEW OR REMANUFACTURED UNLESS OTHERWISE INDICATED. ESTIMATE NO. 161618 FOR 2020-08-01 09:29:00AM. ALL WORK TO BE PERFORMED ON MY VEHICLE FROM THE FRONT OF THIS DOCUMENT.
-921-1156	07:53am	
-921-1156	LABOR RATE	
DATE / TIME PROMISED	PRIORITY	
08/11/20 06:00pm	2	

APPOINTMENT Yes No
ADVISOR: RODNEY KIMPTON SIGNED [REDACTED]

LABOR INSTRUCTIONS

COMMENTS : CUSTOMER REQUESTED A LOANER created 2020-08-01 09:29:00am taken by Rodney Kimpton

- W * 17CDZ-004 ELECTRICAL DIAG 2
C/S: back up camera will not work at times. HAS RED LINE THRU CAMERA.
- W * 01CDZ *MULTI-POINT INSP
PLEASE PERFORM MULTI-POINT INSPECTION
- W * 17CDZ CHASSIS ELECTRICAL
CUSTOMER STATES WHILE DRIVING SCREEN GOES COMPLETELY BLANK. HAS AUDIO BUT SCREEN IS BLANK.

ORDER # 223512

Does not connect to iPhone

7:30 AM 8/12/20

9:20 AM

ORDER # 223512

DATE 8/11/20

ORIGINAL ESTIMATE \$			
DATE			
TIME			
ADDITIONAL AUTHORIZED AMOUNT \$			
ADD'L REPAIRS AUTHORIZED BY			
REVISED AUTHORIZED ESTIMATE \$			
AUTHORIZATION RECEIVED BY			
NAME AND PHONE NUMBER OF OTHER PERSON WHO MAY AUTHORIZE ADD'L REPAIRS			
CHARGE FOR ESTIMATE \$			
DESCRIPTION OF ADD'L WORK AUTHORIZED			
IF THE CHARGE FOR PREPARING AN ESTIMATE CANNOT BE DETERMINED THE CHARGE WILL BE BASED ON 1 HOURLY RATE			
METHOD OF PAYMENT	RENTAL CAR	Y	N
<input type="checkbox"/> CASH	<input type="checkbox"/> CAR	<input type="checkbox"/>	<input type="checkbox"/>
<input type="checkbox"/> CHECK	<input type="checkbox"/> SAVE PARTS	<input type="checkbox"/>	<input type="checkbox"/>
<input type="checkbox"/> VISA	<input type="checkbox"/> BODY SHOP	<input type="checkbox"/>	<input type="checkbox"/>
<input type="checkbox"/> MAS. CARD			
<input type="checkbox"/> AM. EXP.			
BASIS FOR CHARGE	WAITING	<input type="checkbox"/> YES	<input type="checkbox"/> NO
<input type="checkbox"/> FLAT RATE	<input type="checkbox"/> CALL WHEN READY	<input type="checkbox"/>	<input type="checkbox"/>
<input type="checkbox"/> HOURLY RATE	<input type="checkbox"/> YES	<input type="checkbox"/>	<input type="checkbox"/>
<input type="checkbox"/> BOTH			

SF611764 Q (03/17)
The Reynolds and Reynolds Company ERM/HT/MOLE CC732240 Q (05/16)

2200 BEE RIDGE RD.SARASOTA.FL.34239. 922-1571

CUSTOMER INFORMATION				RO#	Unit#	RA#
Customer GANDOR YAROVY						
Home Address				Service Advisor Rod Kimpton		PO
CUSTOMER INFORMATION				VEHICLE INFORMATION		
City	Zip	Date and time OUT Aug 11th 2020, 08:14:44 AM	Date and time IN			
Driver's License No.	Expires	Date and time DUE IN 08/18/2020				
Birth Date	Phone	Vehicle VIN				
ONLY THE BELOW AS ADDITIONAL DRIVERS. IF NONE, PRINT NONE				License No.	State	
Additional Driver's Name		Birth Date	Year	Make		
Driver's License No.	State	Expires	Model	Color		
Additional Driver's Name		Birth Date	Tag #			
Driver's License No.	State	Expires	Miles Allowed			
CUSTOMER INSURANCE INFORMATION				Mileage OUT	Mileage IN	
Insurer	Policy No.	Expiration Date	1016			
Agent	Telephone		Miles Driven	Chargeable Miles		
CUSTOMER INSURANCE INFORMATION				FUEL		
Insured Vehicle Year/Make/Model/Color 2020/Cadillac/XT6				OUT	32.9% (6 gal)	
License No. State				IN		
<input type="checkbox"/> PERMISSION TO TOW TRAILER WITH LOAD CAPACITY IN EXCESS OF 2,000 POUNDS; NOT TO EXCEED MANUFACTURER'S WEIGHT SPECIFICATIONS.				RATES DO NOT INCLUDE FUEL		CHARGES
<p>You are required to return the Vehicle with at least the same amount of fuel as when rented. If you do not return the Vehicle with at least the same amount of fuel; you will pay us a refueling fee of \$ _____ plus fuel @ \$ _____ per gallon.</p> <p>Unless otherwise noted, any daily rate is based on a 24-hour period.</p> <p>The valid and collectible liability insurance and personal injury protection insurance of any authorized rental or leasing driver is primary for the limits of liability and personal injury protection coverage required by §§ 324.021(7) and 627.736, Florida Statutes.</p> <p>Failure to return rented property or equipment upon expiration of the rental period and failure to pay all amounts due (including costs for damage to the property or equipment) are evidence of abandonment or refusal to redeliver the property, punishable in accordance with § 812.155, Florida Statutes.</p> <p>The following are "Prohibited Uses": Use by an unauthorized driver; smoking, vaping or use of tobacco products in the Vehicle; use of the Vehicle by anyone under the influence of alcohol or prescription or non-prescription drugs; and carrying persons or property for hire or providing transportation network company or other transportation services. See Paragraph 6 of the Terms and Conditions for other Prohibited Uses and additional information.</p> <p>By signing below, you agree to the terms and conditions of this Agreement set forth on this Face Page, the Vehicle Condition Report, and all pages of the Vehicle Use Terms and Conditions; acknowledge that you had an opportunity to read the entire Agreement before signing; authorize us to process a separate payment card voucher in your name for all Charges, including Tolls and Violations and to release your billing/rental information to third parties for billing/processing and other legitimate purposes; permit us to reserve against your payment card the amount noted in the Agreement; and authorize us to debit your payment card account to reflect charges. ALL CHARGES SUBJECT TO FINAL AUDIT</p>				HOURS: _____ @ \$ _____ PER HOUR		
				DAYS: _____ @ \$ _____		
				WEEKS: _____ @ \$ _____		
				MILES: _____ @ _____ PER MILE		
				TOTAL TIME & MILEAGE CHARGES →		
TAXABLE FUEL _____ GAL @ \$ _____						
TAXABLE SUB-TOTAL →						
NON-TAXABLE FUEL _____ GAL @ \$ _____						
NET DUE CUSTOMER DEPOSIT / REFUND / OTHER						
SUB-TOTAL						
TOTAL CHARGE →						
METHOD OF PAYMENT	REFUNDED					
<input type="checkbox"/> CHECK <input checked="" type="checkbox"/> AMEX <input type="checkbox"/> MC <input type="checkbox"/> VISA <input type="checkbox"/> OTHER	\$ _____					
08 / 2024 EXPIRES	CUSTOMER INITIALS					
#*****1009	X _____					
<input type="checkbox"/> CARD VERIFIED						

Customer is still in this vehicle...

[Signature]



**CLOSED END MOTOR VEHICLE LEASE
(WITH ARBITRATION PROVISION)**

Lease Date: 12/09/2019

Lessor Name and Business Address SUNSET CADILLAC OF SARASOTA 2200 BEE RIDGE SARASOTA FL 34239	Lessee Name and Address [REDACTED] SARASOTA FL [REDACTED] County: SARASOTA	Co-Lessee Name and Address N/A County:
Lessee Billing Address (if different than above) N/A	Vehicle Garaging Address (if different than above) N/A Principal Driver: N/A (if business use) County:	

In this Lease, "you" and "your" mean the lessee and co-lessee. "We," "us" and "our" mean the lessor, and any assignee of this Lease. The terms, conditions, and disclosures in this Lease govern your Lease with us. Each of you who signs the Lease is jointly and severally liable to us for all Lease obligations. You are leasing the Vehicle described below (the "Vehicle") from us. You agree to pay all amounts due under the Lease and fulfill all your obligations under the Lease. In this Lease, "e" means an estimate. The Consumer Leasing Act Disclosures shown below are also terms of this Lease. You are leasing the Vehicle and have no ownership rights in the Vehicle unless you exercise your purchase option.

Monthly Payment Lease: If your payment schedule shows monthly scheduled payments in Item 3A, your lease is a monthly payment lease.

Single Payment Lease: If your payment schedule shows a single scheduled payment in Item 3B, your lease is a single payment lease.

1. The Vehicle							
New/Used	Year	Make	Model	Body Style	Vehicle ID #	Odometer	Primary Use
NEW	2020	CADILLAC	XT6	PREMIUM LUXU	[REDACTED]	22	Personal, unless otherwise indicated below <input type="checkbox"/> business <input type="checkbox"/> agricultural

CONSUMER LEASING ACT DISCLOSURES			
2. Amount Due at Lease Signing or Delivery (Itemized in Item 6) \$ <u>3278.12</u>	3. Scheduled Payments A. Your first monthly payment of \$ <u>668.12</u> is due on <u>12/09/19</u> followed by <u>38</u> monthly payments of \$ <u>668.12</u> , due on the <u>9th</u> of each month. B. Your single payment of \$ <u>N/A</u> is due on <u>N/A</u> . C. The Total of your Scheduled Payments is \$ <u>26056.68</u> .	4. Other Charges (not part of your scheduled payment) A. Disposition fee (if you do not purchase the Vehicle and we do not waive the fee under Item 23(t)) \$ <u>595.00</u> B. <u>N/A</u> \$ <u>N/A</u> C. <u>N/A</u> \$ <u>N/A</u> D. Total \$ <u>595.00</u>	5. Total of Payments (The amount you will have paid by the end of the Lease) \$ <u>29261.68</u> (2 + 3C + 4D - 6A3 - 6A4 - 6A5)

6. Itemization of Amount Due at Lease Signing or Delivery	
A. Amount Due at Lease Signing or Delivery:	B. How the Amount Due at Lease Signing or Delivery will be paid:
1. Capitalized cost reduction \$ <u>2211.53</u>	1. Net trade-in allowance \$ <u>N/A</u>
2. Taxes on capitalized cost reduction \$ <u>154.81</u>	2. Rebates and noncash credits \$ <u>2610.00</u>
3. First monthly payment \$ <u>668.12</u>	3. Amount to be paid in cash \$ <u>668.12</u>
4. Single scheduled payment \$ <u>N/A</u>	4. Other <u>N/A</u> \$ <u>N/A</u>
5. Refundable security deposit \$ <u>N/A</u>	5. Total \$ <u>3278.12</u>
6. Lease acquisition fee \$ <u>N/A</u>	
7. Title fees \$ <u>N/A</u>	
8. License and registration fees \$ <u>98.75</u>	
9. Sales/use tax \$ <u>9.91</u>	
10. DOC FEE \$ <u>75.00</u>	
11. RENTAL SURCHARGE \$ <u>60.00</u>	
12. Total \$ <u>3278.12</u>	

7. Your scheduled payment is determined as shown below:	
A. Gross capitalized cost. The agreed upon value of the Vehicle (\$ <u>55391.44</u>) and any items you pay over the Lease term (such as service contracts, insurance, and any outstanding prior credit or lease balance).	\$ <u>57181.44</u>
B. Capitalized cost reduction. The amount of any net trade-in allowance, rebate, noncash credit, or cash you pay that reduces the gross capitalized cost.	- \$ <u>2211.53</u>
C. Adjusted capitalized cost. The amount used in calculating your base scheduled payment.	= \$ <u>54969.91</u>
D. Residual value. The value of the Vehicle at the end of the Lease used in calculating your base scheduled payment.	- \$ <u>32424.30</u>
E. Depreciation and any amortized amounts. The amount charged for the Vehicle's decline in value through normal use and for other items paid over the Lease term.	= \$ <u>22545.61</u>
F. Rent charge. The amount charged in addition to the depreciation and any amortized amounts.	+ \$ <u>1806.38</u>
G. Total of base scheduled payments. The depreciation and any amortized amounts plus the rent charge.	= \$ <u>24351.99</u>
H. Lease payments. The number of payments in your Lease.	÷ <u>39</u>
I. Base scheduled payment.	= \$ <u>624.41</u>
J. Sales/use tax (e).	+ \$ <u>43.71</u>
K. <u>N/A</u>	+ \$ <u>N/A</u>
L. <u>N/A</u>	+ \$ <u>N/A</u>
M. Total Scheduled Payment.	= \$ <u>668.12</u>

Early Termination. You may have to pay a substantial charge if you end this Lease early. The charge may be up to several thousand dollars. The actual charge will depend on when the Lease is terminated. The earlier you end the Lease, the greater this charge is likely to be.

8. Excessive Wear and Use. You may be charged for excessive wear based on our standards for normal use and for mileage in excess of 10000 miles per year at the rate of \$ 0.25 per mile.

9. Purchase Option at End of Lease Term. You have an option to purchase the Vehicle at the end of the Lease term for \$ 32424.30 plus a purchase option fee of \$ N/A. The purchase option price does not include official fees such as those for taxes, tags, licenses and registration.

10. Other Important Terms. See your Lease documents for additional information on early termination, purchase options, maintenance responsibilities, warranties, late and default charges, insurance, and any security interest, if applicable.

Lessee Initials [REDACTED] Lessee Initials X N/A

Notice is hereby given that the rights, but not the obligations, of N/A to purchase and/or sell the asset described in this Lease have been assigned to N/A pursuant to an agreement between N/A and N/A.

NOTICE TO THE LESSEE: DO NOT SIGN THIS LEASE BEFORE YOU READ IT OR IN BLANK. YOU ARE ENTITLED TO A COPY OF THIS LEASE WHEN YOU SIGN IT. KEEP IT TO PROTECT YOUR LEGAL RIGHTS.

YOU AGREE TO THE TERMS OF THIS LEASE. YOU ACKNOWLEDGE YOU HAVE EXAMINED THE VEHICLE, THAT THE VEHICLE IS EQUIPPED AS YOU WANT, AND THAT IT IS IN GOOD CONDITION. YOU ACCEPT THE VEHICLE FOR ALL PURPOSES OF THE LEASE. YOU UNDERSTAND THAT YOU HAVE NO OWNERSHIP RIGHTS IN THE VEHICLE UNLESS YOU EXERCISE YOUR OPTION TO PURCHASE THE VEHICLE. YOU CONFIRM THAT BEFORE YOU SIGNED THIS LEASE, WE GAVE IT TO YOU, AND YOU WERE FREE TO TAKE IT AND REVIEW IT. YOU ACKNOWLEDGE THAT YOU READ ALL PAGES OF THIS LEASE, INCLUDING THE ARBITRATION PROVISION ON PAGE 5 OF THIS LEASE (ITEM 24), BEFORE SIGNING BELOW. YOU CONFIRM THAT YOU RECEIVED A COMPLETELY FILLED-IN COPY WHEN YOU SIGNED THIS LEASE.

LESSEE SIGNATURES

Lessee Signature <u>[Redacted]</u> Date <u>12/09/19</u>	Co-Lessee Signature <u>N/A</u> Date <u>N/A</u>
Type/Print Lessee Name <u>[Redacted]</u>	Type/Print Co-Lessee Name <u>N/A</u>

COMMERCIAL LESSEE SIGNATURE

Commercial Lessee <u>N/A</u> Date <u>N/A</u> By <u>N/A</u>	Type/Print Name <u>N/A</u> Type/Print Title <u>N/A</u>
--	--

21. DEFAULT, REPOSSESSION AND OTHER REMEDIES

If any of the following occurs, you will be in default under this Lease: • You do not pay any payment on its scheduled due date under this Lease; • You do not pay any other amount due under this Lease when we ask that you pay it; • You provide any false or misleading information in any Lease application; • You fail to maintain required insurance; • You lose possession of the Vehicle by confiscation, forfeiture or other involuntary transfer whether or not the Vehicle is the subject of judicial or administrative proceedings; • You assign the Lease or transfer the Vehicle without our prior written permission, or attempt to do either; • You start a bankruptcy, receivership, or insolvency proceeding or one is started against you or your property; • You do anything that endangers the Vehicle or your ability to pay your Lease obligations; • You fail to return the Vehicle when required to do so under this Lease; • You fail to meet any other obligation under this Lease; • You do anything the law says is a default.

If you are in default, after waiting any time the law requires, we may do any of the following: • End this Lease and require you to pay the amount due at early termination; • Take any action we believe is required to protect our interest in the Vehicle (for example buying insurance) and our action will not cure your default; • Add any amounts we spend taking these actions to your Lease obligation and charge rent on the amount added, or at our option, ask you to pay these amounts right away; • If the Vehicle has an electronic locating device, use it to find the Vehicle; • Cancel any optional products and services included with this Lease and apply any refund to your Lease obligations (you hereby instruct any provider of such products and services to pay us any refund or credit due on early cancellation); • Take (repossess) the Vehicle wherever we find it and enter any property where the Vehicle may be to do so; • Sue you for damages or to get the Vehicle back; • Pursue any other remedy the law gives us.

We will exercise our rights without breach of the peace, at reasonable times and places, in a reasonable way, as the law allows. We may use the license plates on the Vehicle to move it to a storage place. After repossessing the Vehicle, we will hold it free of any rights you may have under this Lease, subject to any right the law gives you to cure the default or recover the Vehicle. We may take and store any personal items that are in the Vehicle. If you do not ask for these items back, we may dispose of them as the law allows. Unless you tell us within five business days of any personal property you claim was in the Vehicle when it was repossessed, we will not be responsible for that property. You will pay our reasonable expenses of taking these actions as the law allows. These expenses may include expenses of taking and storing the Vehicle, attorney's fees, collection costs, and court costs.

22. EARLY TERMINATION LIABILITY

When the Lease Can End Early. You may terminate (end) the Lease early by returning the Vehicle to us and paying us your early termination liability (see below) when we ask for it.

We may end the Lease early if you are in default; the Vehicle is damaged or destroyed beyond repair, stolen or lost (a "Total Loss"); or you die and there is no surviving lessee. If we end the Lease, you must return the Vehicle to the place we designate and pay us the early termination liability (see below) when we ask for it.

Early Termination Liability. We will figure your early termination liability as follows:

Monthly Payment Lease. You will owe the amount, if any, by which the Adjusted Lease Balance (see definition) exceeds the Vehicle's Fair Market Wholesale Value (see definition) at termination. If this amount is more than the total of the following amounts, you will instead pay the total of the following amounts: • The total of your base scheduled payments not yet due; • An excess wear charge (see Item 23(c)); and • An excess mileage charge for any miles in excess of the permitted mileage during the scheduled Lease term at the rate per mile shown in Item 8.

Single Payment Lease. The Base Scheduled Payment (Item 7I) paid at lease signing prepaids the depreciation and any amortized amounts (Item 7E) and the rent charge (Item 7F). If the Vehicle's Fair Market Wholesale Value at termination (see definition) exceeds the Adjusted Lease Balance (see definition), we will give you a credit for the excess up to the amount of the Unused Base Scheduled Payment (see definition). If the Adjusted Lease Balance exceeds the Vehicle's Fair Market Wholesale Value at termination, you will owe the excess up to the total of the following amounts: • An excess wear charge (see Item 23(c)); and • An excess mileage charge for any miles in excess of the permitted mileage during the scheduled Lease term at the rate per mile shown in Item 8.

In addition to the amounts described above, you will also owe us the Item 4A Disposition Fee unless this fee is waived under Item 23(f) plus the Additional Amounts Due and we will apply the Additional Credits to the amount you owe (see Item 23(s)).

Definition of Adjusted Lease Balance:

Monthly Payment Lease. The Adjusted Lease Balance equals the difference between: (1) The Item 7C Adjusted Capitalized Cost; and (2) all depreciation and amortized amounts in the base scheduled payments that have become due. Each Item 7I Base Scheduled Payment consists of: • a rent charge portion; and • a portion allocable to depreciation and any amortized amounts. Although the amount of your Item 7I Base Scheduled Payment does not change, different portions of each Base Scheduled Payment are allocated to: • rent charge; and • depreciation and any amortized amounts. The portion of a Base Scheduled Payment that is allocated to depreciation and any amortized amounts is equal to the Base Scheduled Payment minus the rent charge for that month. We use the Constant Yield Method to figure the rent charge portion of each Base Scheduled Payment. Under the "Constant Yield Method," the rent charge for each scheduled period is earned in advance by multiplying the constant rate implicit in this Lease times the Balance Subject to Rent Charge as it declines during the Lease term. At any given time during the Lease term, the "Balance Subject to Rent Charge" is the difference between the Item 7C Adjusted Capitalized Cost and the sum of: (i) all depreciation and amortized amounts accrued during the previous periods, and (ii) any Base Scheduled Payment paid at Lease signing or delivery. The scheduled rent charge calculations are based on the assumption that we will receive your scheduled payments on their exact due dates and that the Lease goes to its full term.

Single Payment Lease. The Adjusted Lease Balance at the beginning of the Lease equals: (i) The Item 7C Adjusted Capitalized Cost; minus (ii) the Item 7I Base Scheduled Payment. At the beginning of each month, the Adjusted Lease Balance increases by the rent charge for that month. We use the Constant Yield Method to figure the rent charge for each month. Under the "Constant Yield Method" the rent charge for each monthly period is earned in advance by multiplying the constant rate implicit in this Lease times the Balance Subject to Rent Charge as it increases during the Lease term. At any given time during the Lease term, the "Balance Subject to Rent Charge" equals: (i) the Item 7C Adjusted Capitalized Cost; minus (ii) the Item 7I Base Scheduled Payment; plus (iii) all rent charges accrued during previous periods. The rent charge calculations are based on the assumption that the Lease goes to its full term.

Definition of Fair Market Wholesale Value: Unless you exercise your independent appraisal right (see below), the Fair Market Wholesale Value of the Vehicle is: • the price we receive for the Vehicle at disposition; • the highest offer we receive for disposition of the Vehicle; • the amount you and we agree in writing; • or the wholesale fair market value of the Vehicle.

Definition of Unused Base Scheduled Payment (Single Payment Lease): The Unused Base Scheduled Payment equals: (i) the Item 7I Base Scheduled Payment; divided by (ii) the number of months in the Lease Term (Item 19B); times (iii) the number of full months remaining after the date of the early termination until the Scheduled Lease End (Item 19A).

Your Independent Appraisal Right: To the extent your early termination liability takes into account the value of the Vehicle at termination, you may get a professional appraisal of the Vehicle's fair market wholesale value. If you do so within a reasonable time, we will use the appraised value as the Fair Market Wholesale Value. The appraiser must be an independent third party. You and we must agree on the appraiser. You must pay for any appraisal. The appraisal will be binding.

23. OTHER TERMS AND CONDITIONS

(a) **Insurance.** For the duration of the Lease term, and until you return the Vehicle, you agree to maintain the amounts and types of primary insurance as indicated in Item 18 on page 2 of this Lease in your name. Insurance may be obtained by you from anyone reasonably acceptable to us. You must indicate us or anyone we require as an additional insured and loss payee on your policy. Your policy must state that we will be given at least 10 days' notice of any material coverage change, reduction, or cancellation. If your insurer does not pay a claim for any reason, it will mean that you have not maintained the required insurance. You will pay for any loss we incur because you do not maintain required insurance or because the insurer does not pay a claim. If you fail to obtain and maintain the required insurance, we may, if we choose, buy it for you. We may add the amount we pay for this insurance to your unpaid Lease obligations and charge rent on the amount added, or at our option, ask you to pay it right away. If we decide to buy this insurance, we may either buy insurance that covers your interest and our interest, or buy insurance that covers only our interest, unless the law requires us to buy insurance that also protects your interests. If the Vehicle is damaged, stolen, or destroyed, and money becomes available from insurance, a judgment, a settlement, or the like, we will be entitled to the money. If the Lease ends in connection with our receipt of the money, we will treat any of the money we do not use to repair the Vehicle as part of the price we received for the Vehicle at disposition.

NOTICE: PHYSICAL DAMAGE OR LIABILITY INSURANCE COVERAGE FOR BODILY INJURY AND PROPERTY DAMAGE TO OTHERS IS NOT INCLUDED IN THIS LEASE.

- (r) **Notice and Agreement Regarding E-Mails and Calls/Text Messages to Wireless Telephones:** You agree, in order for us to service your account or to collect any amounts you may owe, we may contact you by telephone at any telephone number associated with your account, including land-line, wireless, cellular, or VoIP/internet telephone numbers, which could result in charges to you. We may also contact you at any e-mail address you provide to us or by sending text messages, which could result in charges to you. Methods of contact may include using pre-recorded/artificial voice messages and/or use of an automatic dialing device, as applicable. Your agreement and consent also extends to any other agents, affiliates, or entities to whom we may assign, transfer, or sell your obligation for servicing or collection. You may revoke this consent for any telephone number or email address by contacting us and letting us know.
- (s) **Additional Amounts Due and Additional Credits:** Regardless of how this Lease ends, you will owe us the following amounts: • Any official fees and taxes related to the termination. • Any other amounts due under this Lease including any unpaid late charges or other amounts due because you failed to meet your obligations under this Lease. If this Lease ends early, we may cancel any optional insurance, maintenance, service, or other contracts included in this Lease or claim benefits under them to reduce what you owe or repair the Vehicle. If the sum of the amounts you owe under this Lease exceeds the sum of the credits, you will owe us the difference. If the sum of the credits exceeds the amounts you owe, we will refund the difference to you.

- (t) **Disposition Fee Waiver:** The Item 4A Disposition Fee will be waived if you purchase or lease a new General Motors vehicle when this Lease ends.
- (u) **Limited Power of Attorney.** If there is any damage or loss to the Vehicle, you agree that we or our agent may settle any insurance claim or sign your name on any title or registration or on any check or draft we receive for that Vehicle damage or loss.
- (v) **General.** If any part of this Lease is invalid, unenforceable or illegal in any jurisdiction, the part that is invalid, unenforceable or illegal will not be effective as to that jurisdiction. The rest of the Lease will be enforceable except as provided in the Arbitration Provision, below. This Lease is our entire agreement. We have made no promises to you not contained in this Lease. If any part of this Lease is found by a court or other dispute resolution body to be void or unenforceable, this Lease is to be read as if that part were never contained in this Lease.

Lessor's Right to Cancel

- a. Lessor agrees to deliver the vehicle to you on the date this Lease is signed by Lessor and you. You understand that it may take a few days for Lessor to verify your credit, locate financing for you on the exact terms shown on page 1 of this Lease, and assign this Lease to a financial institution. You agree that Lessor has the number of days stated on page 2 of this Lease to assign this Lease. You agree that if Lessor is unable to assign this Lease within this time period to any one of the financial institutions with whom Lessor regularly does business under an assignment acceptable to Lessor, Lessor may cancel this Lease. Lessor's right to cancel this Lease ends upon assignment of this Lease.
- b. If Lessor elects to cancel per Paragraph a. above, Lessor will give you written notice (or in any other manner in which actual notice is given to you). In that event, you may have the option of negotiating and signing a new Lease with different financing terms (for example, a larger down payment, a higher annual percentage rate, a required cosigner, etc.) or you may pay with alternate funds arranged by you.
- c. Upon receipt of the notice of cancellation, you must return the vehicle to Lessor within 48 hours in the same condition as when sold other than reasonable wear for the time you had it. Except as described below, Lessor must give you back all consideration Lessor has received from you in connection with this Lease.
- d. If you do not return the vehicle within 48 hours after receipt of the notice of cancellation, you agree that Lessor may use any lawful means to take it back (including repossession if done peacefully) and you will be liable for all expenses incurred by Lessor in taking the vehicle from you, including reasonable attorney's fees. If you fail to return the vehicle within 48 hours after receipt of the notice of cancellation, you agree to pay Lessor the charge shown in the Lessor's Right to Cancel provision on page 2 of this Lease for each day you do not return the vehicle after receipt of the notice of cancellation.
- e. While the vehicle is in your possession, all terms of this Lease, including those relating to use of the vehicle and insurance for the vehicle, are in full force and you assume all risk of loss or damage to the vehicle. You must pay all reasonable costs for repair of any damage done to the vehicle while the vehicle is in your possession. Lessor may deduct from any consideration due to you under paragraph c. above Lessor's reasonable costs to repair the vehicle and any daily charges you incur if you fail to return the vehicle within 48 hours after receipt of the notice of cancellation. If Lessor cancels this Lease, the terms of this Lessor's Right to Cancel provision (including those on page 2 of this Lease) remain in effect even after you no longer have possession of the vehicle.

24. ARBITRATION PROVISION

ARBITRATION PROVISION

PLEASE REVIEW - IMPORTANT - AFFECTS YOUR LEGAL RIGHTS

- EITHER YOU OR WE MAY CHOOSE TO HAVE ANY DISPUTE BETWEEN US DECIDED BY ARBITRATION AND NOT IN COURT OR BY JURY TRIAL.
- IF A DISPUTE IS ARBITRATED, YOU WILL GIVE UP YOUR RIGHT TO PARTICIPATE AS A CLASS REPRESENTATIVE OR CLASS MEMBER ON ANY CLASS CLAIM YOU MAY HAVE AGAINST US INCLUDING ANY RIGHT TO CLASS ARBITRATION OR ANY CONSOLIDATION OF INDIVIDUAL ARBITRATIONS.
- DISCOVERY AND RIGHTS TO APPEAL IN ARBITRATION ARE GENERALLY MORE LIMITED THAN IN A LAWSUIT, AND OTHER RIGHTS THAT YOU AND WE WOULD HAVE IN COURT MAY NOT BE AVAILABLE IN ARBITRATION.

Any claim or dispute, whether in contract, tort, statute or otherwise (including the interpretation and scope of this Arbitration Provision, and the arbitrability of the claim or dispute), between you and us or our employees, agents, successors or assigns, which arises out of or relates to your credit application, lease or condition of this Vehicle, this Lease or any resulting transaction or relationship (including any such relationship with third parties who do not sign this Lease) shall, at your or our election, be resolved by neutral, binding arbitration and not by a court action. If federal law provides that a claim or dispute is not subject to binding arbitration, this Arbitration Provision shall not apply to such claim or dispute. Any claim or dispute is to be arbitrated by a single arbitrator on an individual basis and not as a class action. You expressly waive any right you may have to arbitrate a class action. You may choose the American Arbitration Association, (www.adr.org), or any other organization to conduct the arbitration subject to our approval. You may get a copy of the rules of an arbitration organization by contacting the organization or visiting its website.

Arbitrators shall be attorneys or retired judges and shall be selected pursuant to the applicable rules. The arbitrator shall apply governing substantive law and the applicable statute of limitations. The arbitration hearing shall be conducted in the federal district in which you reside unless the Lessor named on page 1 of this Lease is a party to the claim or dispute, in which case the hearing will be held in the federal district where this Lease was executed. You and we will pay the filing, administration, service, or case management fee and the arbitrator or hearing fee in accordance with the rules and procedures of the chosen arbitration organization. If the rules of the chosen arbitration organization do not specify how fees must be allocated, we will pay the filing, administration, service or case management fee and the arbitrator or hearing fee up to a maximum of \$5,000, unless the law requires us to pay more. The amount we pay may be reimbursed in whole or in part by decision of the arbitrator if the arbitrator finds that any of your claims is frivolous under applicable law. Each party shall be responsible for its own attorney, expert and other fees, unless awarded by the arbitrator under applicable law. If the chosen arbitration organization's rules conflict with this Arbitration Provision, then the provisions of this Arbitration Provision shall control.

Any arbitration under this Arbitration Provision shall be governed by the Federal Arbitration Act (9 U.S.C. § 1 et seq.) and not by any state law concerning arbitration. Any award by the arbitrator shall be in writing and will be final and binding on all parties, subject to any limited right to appeal under the Federal Arbitration Act.

You and we retain the right to seek remedies in small claims court for disputes or claims within that court's jurisdiction, unless such action is transferred, removed or appealed to a different court. Neither you nor we waive the right to arbitrate by using self-help remedies, such as repossession, or by filing an action to recover the Vehicle, to recover amounts you owe under this Lease, or for individual injunctive relief. Any court having jurisdiction may enter judgment on the arbitrator's award. This Arbitration Provision shall survive any termination, payoff or transfer of this Lease. If any part of this Arbitration Provision, other than waivers of class action rights, is deemed or found to be unenforceable for any reason, the remainder shall remain enforceable. If a waiver of class action rights is deemed or found to be unenforceable for any reason in a case in which class action allegations have been made, the remainder of this Arbitration Provision shall be unenforceable.

25. LESSOR'S ASSIGNMENT

Pursuant to the terms of that certain agreement between Lessor and the assignee named below ("Assignee") for the assignment of leases by Lessor to Assignee from time to time, Lessor hereby assigns all right, title and interest in the Lease and the Vehicle and rights the Lessor may have under any guaranty executed in connection with the Lease, with full powers to Assignee to collect and discharge all obligations, any guaranty and this assignment.

LESSOR'S ACCEPTANCE

The Lessor's authorized signature indicates the Lessor has accepted the terms, conditions and	
Lessor Name: SUNSET CADILLAC OF SARASOTA	By: _____
Lienholder Name: WELLSFRGO AS CTL AGT	Type/Print Name: _____
Assignee Name: ACAR Leasing Ltd., Inc.	Type/Print Title: BUS MGR



Lessee Initials _____ Co-Lessee Initials X N/A

Sunset Cadillac of Sarasota
Volvo of Sarasota
Infiniti of Sarasota
2200 Bee Ridge Road
Sarasota, FL 34239

CASH RECEIVED FROM

[REDACTED]
[REDACTED]
[REDACTED]
SARASOTA, FLORIDA [REDACTED]

NUMBER [REDACTED]

RECEIVED BY [REDACTED]
DATE 12/10/19
TIME 14:22

ACCT.	AMOUNT	CONTROL NUMBER
220A	668.12	[REDACTED]

PAYMENT TYPE	AMOUNT
PERSONAL CHECK	668.12

COPY

PAGE 1

RECEIPT
RECEIPT

[REDACTED]

CASH RECEIVED FROM

[REDACTED]
[REDACTED]
[REDACTED]
SARASOTA, FLORIDA [REDACTED]

NUMBER [REDACTED]

RECEIVED BY [REDACTED]
DATE 12/10/19
TIME 14:22

ACCT.	AMOUNT	CONTROL NUMBER
[REDACTED]	668.12	[REDACTED]

PAYMENT TYPE	AMOUNT
PERSONAL CHECK	668.12

The Reynolds and Reynolds Company (HARS) (FORM) SF611761 Q (09/15)

COPY

PAGE 1

Sunset Cadillac of Sarasota
Volvo of Sarasota
Infiniti of Sarasota
2200 Bee Ridge Road
Sarasota, FL 34239

SIGNATURE

RETAIL LEASE ORDER

DATE **12/09/2019**

CUSTOMER [REDACTED]			DOB 06/11/1951			CO-CUSTOMER N/A			DOB N/A					
ADDRESS [REDACTED]						ADDRESS N/A								
CITY SARASOTA		STATE FL		ZIP [REDACTED]		CITY N/A		STATE N/A		ZIP N/A				
E-MAIL [REDACTED]@YAHOO.COM						E-MAIL N/A								
HOME PHONE [REDACTED]		WORK PHONE [REDACTED]		COUNTY SARASOTA		HOME PHONE N/A		WORK PHONE N/A		COUNTY N/A				
STOCK NO. 30081		YEAR 2020	NEW XX	USED	DEMO	EXECUTIVE	MILEAGE 22		COLOR CRYST WHITE T		SALESPERSON 1			
VIN [REDACTED]			MAKE CADILLAC			MODEL XT6			BODY PREMIU			SALESPERSON 2		

NEW / DEMO AND EXECUTIVE VEHICLE DISCLOSURE
 The new, demonstrator or executive Vehicle is leased AS-IS and WITH ALL FAULTS. Dealer hereby expressly disclaims all warranties, either express or implied, including any implied warranties of merchantability or fitness for a particular purpose and neither assumes nor authorizes any other person to assume for it any liability in connection with the lease of the Vehicle. The only warranties applying to this Vehicle are those offered by the Manufacturer. The Manufacturer's warranty is not affected by Dealer's disclaimer of warranties. The Customer hereby acknowledges that Dealer has made available "warranty Pre-Sale Information" as disclosed in [REDACTED]

Customer: **N/A**
 THIS VEHICLE WAS DELIVERED TO A PREVIOUS PURCHASER.
 Customer: _____ Customer: **N/A**

USED VEHICLE DISCLOSURE
 This used Vehicle has been previously driven by others and Dealer has not made any representation regarding the Vehicle's history. Customer acknowledges that no representation has been made by any agent of Dealer: (i) regarding the history, condition, prior repair or maintenance, safety system or suitability of the Vehicle; or (ii) that it has or has not ever sustained damages prior to this Order, nor does Dealer have the obligation to make any such disclosure. Customer understands that s/he may retain a third-party to provide information regarding the Vehicle's history and that Dealer encourages Customer to do so. Customer may also make arrangements to have the Vehicle inspected by a person of Customer's own choosing. Customer further acknowledges that Customer has test driven this Vehicle and it meets Customer's satisfaction or Customer has been offered an opportunity to do so, and has declined. Except as otherwise set forth on the window form (Buyer's Guide), this Vehicle is leased "AS IS and WITH ALL FAULTS," without any warranty and Dealer hereby expressly disclaims all warranties, either express or implied, including any implied warranty of merchantability or fitness for a particular purpose, and neither assumes nor authorizes any person to assume for it any liability in connection with the sale of the Vehicle. The manufacturer warranty, if any, has been fully explained. If the Vehicle is designated as a certified vehicle, that indicates that it has qualified for a limited extension of the Manufacturer's original warranty as set forth on the Buyer's Guide. The certified designation does not alter or modify any of the above disclaimers and waivers, nor does it create a Dealer warranty. It also does not mean that the Vehicle, like all used vehicles, will not suffer mechanical breakdowns, nor need maintenance due to wear and tear.

The Vehicle was previously a **N/A** (enter short-term rental, taxicab, police vehicle, manufacturer buy-back, rebuilt, glider kit, replica or flood vehicle).
 Customer: **N/A** Customer: **N/A**

Used Car Buyers Guide. The information you see on the window form for this vehicle is part of this contract. Information on the window form overrides any contrary provisions in the contract of sale.
 Guía para compradores de vehículos usados. La información que ve en el formulario de la ventanilla para este vehículo forma parte del presente contrato. La información del formulario de la ventanilla deja sin efecto toda disposición en contrario contenida en el contrato de venta.

LEASE INFORMATION	
Cash Price of Vehicle	54596.44
Extended Service Plan	N/A
Accessories /Options	N/A
N/A	N/A
N/A	N/A
N/A	N/A
OTHER AFTERMARKETS	795.00
N/A	N/A
SUBTOTAL CAPITALIZED COST	55391.44
Predelivery Service Charge**	75.00
Electronic Registration Filing Fee**	N/A
** These charges represent costs and profit to the dealer for items such as inspecting, cleaning, and adjusting vehicles, and preparing documents related to the sale.	
Florida New Tire Fee & Lead Acid Battery Fee	6.50
N/A	N/A
Sales Tax 6.00%	141.18
Rental Surcharge	60.00
County Tax	23.54
Lemon Law – Warranty Enforcement Act (New Cars Only)	2.00
Florida Title, Registration and License Fees (New Trans XX) <input type="checkbox"/> If box is checked this is an estimate	65.85
PTA FEE/ACQ FEE / ADV PMT	1342.52
Trade Pay-off / Balance on Prior Lease	1140.00
Pre-owned Allowance &/or Discount	N/A
TOTAL CAPITALIZED COST	58248.03
Net Trade Equity Applied Towards Lease inception costs and/or capitalized cost reduction	N/A
Additional Amounts Paid Towards Lease inception costs and/or capitalized cost reduction	668.12
Rebates	2610.00

TERMS AND CONDITIONS

A. Definitions: As used in this Order the terms: (a) "Customer" shall mean the party(ies) acquiring the Vehicle; (b) "Vehicle" shall mean the vehicle which is the subject of this Order; (c) "Manufacturer" shall mean the manufacturer that manufactured the Vehicle; (d) "Trade-In" shall mean the automobile(s), but not a Lease Walk Away, conveyed by Customer to Dealer and described on page 2 of this Order, which is being applied towards the acquisition costs of the Vehicle; (e) "ACV" shall mean the actual cash value of the Trade-In, as determined by the National Auto Research Black Book Official Used Car Market Guide based on its condition, current as of the date of Customer's delivery of the Trade-In to Dealer, or if the Trade-In is too old to be in such guide, the average auction price at the time of this Order at the Central Florida Automobile Auctions (open only to licensed automobile dealerships) of automobiles of similar equipment, condition model and year as the Trade-In; (f) "Pre-owned Allowance &/or Discount" as identified on page 1 of this Order is the sum of the ACV plus any discount and/or credit given by Dealer towards the price of the Vehicle; (g) "Demonstrator" (as defined by Chapter 320, Florida Statutes), commonly referred to as "Demo" will be considered a new Vehicle; and (h) "executive vehicle" refers to a vehicle used exclusively by Manufacturer, its subsidiary, or a dealer for the commercial or personal use of the manufacturer's, subsidiary's, or dealer's employees and is considered a new Vehicle; and (i) "Lease Agreement" means an agreement by which the Vehicle is provided on a rental payment basis, subject to agreed upon terms and conditions. Terms in general will be interpreted based on Florida statutory definitions, if any.

B. Vehicle: Customer must accept and take delivery of Vehicle within 48 hours from its availability. Failure by Customer to do so shall constitute a material breach of this Order. By taking possession of Vehicle, Customer, unless otherwise confirmed in writing by Dealer, acknowledges that Vehicle has no defects, flaws or irregularities that would be detected during a visual examination and that no equipment or option is missing. Dealer shall not be liable for failing to deliver or for any delay in delivery where such failure or delay is due, in whole or in part, to any cause beyond the control or without the fault or negligence of Dealer. Manufacturer has reserved the right to change the design of any new motor vehicle, chassis and any accessories or parts thereof at any time without notice and without obligation to make the same or any similar change upon any motor vehicle, chassis, accessories or parts thereof previously purchased by or shipped to Dealer or being manufactured or sold in accordance with Dealer's contracts. In the event of any such change by Manufacturer, Dealer shall have no obligation to Customer to make the same or any similar change in any motor vehicle, chassis, accessories or parts thereof covered by this Order either before or subsequent to delivery thereof to Customer. Dealer shall have no duty to disclose intended design changes by Manufacturer. Line item(s) of optional Dealer installed accessories, equipment listed on page 1 of this Order, service contracts or extended service policy shall not be construed as having been produced, supplied, issued by or installed by Manufacturer. With respect to a new Vehicle, all equipment and options existing at the time the Vehicle was shipped by the Manufacturer were produced by the Manufacturer and/or its world wide suppliers. Items installed thereafter may not be products of the Manufacturer. Neither the Manufacturer, nor Dealer warrant these items. Dealer does not warrant or guarantee the mileage indicated on the used Vehicle is accurate or that it may not have been altered by persons in possession prior to Dealer. Customer acknowledges that new vehicles may be delivered by the Manufacturer with some in-transit damage and acknowledges that sometimes new vehicles are damaged from being moved on or around the Dealer's property. Customer acknowledges that Customer may not be advised, except as required by Florida Statutes, if such damage occurs to a new Vehicle and is repaired.

C. Trade-In: Customer grants, bargains, conveys, sells, assigns and transfers to Dealer all of Customer's right, title and interest in the Trade-In. Customer fully warrants title to the Trade-In and that it is free and clear of all liens and encumbrances except as otherwise noted herein and will defend same against the claims of all persons whomsoever. Customer agrees to deliver to Dealer satisfactory evidence of title to any Trade-In at the time of its delivery to Dealer. If Customer fails to pay any undisclosed or understated liens, Customer shall be in material breach of this Order. In the event that the Trade-In has more mileage than represented by Customer or any of Customer's representations regarding the Trade-In are false, Customer shall be obligated to pay Dealer the difference between the ACV of the Trade-In as represented and the correct ACV within 10 days from written demand. Dealer may recover all consequential and incidental damages arising from Customer's breach of any warranty regarding the Trade-In. Dealer may reappraise the Trade-In if before its possession is delivered to Dealer, it is damaged or parts or accessories have been removed. If such reappraised value results in a "Pre-owned Allowance &/or Discount" that is lower than the allowance shown hereon, Customer may, if dissatisfied therewith, terminate this Order.

D. Rebates / Payment / Incentives: Dealer has no obligation to disclose to Customer the availability of any incentives or rebate. All incentives and rebates shown on page 1 hereof are hereby assigned to Dealer. If Customer is receiving a discount or credit based on a specific relationship with the Manufacturer, Customer must furnish all necessary documentation, information, verification and certificates within 30 days. In the event that Customer fails to timely do so or in the event any moneys to be paid at inception are not paid or non-negotiable (i.e., NSF), Customer shall be in breach of this Order.

E. Mandatory Mediation: Before any party institutes an action, other than one that is expressly outside the scope of the arbitration provision, the parties must first mediate the dispute before a court certified mediator, which mediation shall be conducted in the county where the Dealer is situated. The parties shall jointly select the mediator and equally divide the cost of the mediation. The parties shall use good faith in selecting the mediator and participating in the mediation.

F. Additional Equipment and Accessories: If the vehicle has equipment or accessories other than as described on the Manufacturer's window sticker, such items may have been fabricated or distributed by other than the Manufacturer and may not be endorsed

by the Manufacturer. In such instance(s), the equipment or accessory will not be covered by the Manufacturer's express limited warranty covering the Vehicle. Check with Dealer for a list of any such equipment or accessory on the Vehicle.

G. Miscellaneous: This Order shall survive the execution of the Lease Agreement. To the extent any terms herein conflict with the terms of the Lease Agreement (except as to dollar amounts), this Order shall control and govern. Waste tire fees and lead-acid battery fees, if applicable and if included in the price of Vehicle, are payable to the State of Florida, Department of Revenue. Dealer is not the agent of the Manufacturer. This Order cancels and supersedes any prior contract and comprises the complete and exclusive statement of the terms of the Order relating to the subject matters covered hereby, and constitutes the entire Order between the parties. There are no representations or contracts between the parties except as set forth herein or contemporaneously executed. This Order may not be changed, modified or extended except by an instrument in writing and signed by the parties. In the event this Order or any other contract or document executed by Customer contains a clerical or computation error or if additional documentation is necessary in order to effectuate the parties' intent, Customer agrees to cooperate with the execution of such (corrected) documentation and produce the additional documentation. Should Customer unreasonably refuse to give such cooperation, Customer shall be in material breach of this Order. By execution of this Order, Customer certifies being 18 years old or older. Customer has read, understands and accepts all provisions of this Order and the Warranty Statement. The parties enter into this Order freely and voluntarily in the absence of any duress or coercion. Customer agrees to pay, unless prohibited by law, any and all taxes applicable to this transaction, regardless of which party may have the primary tax liability therefor. The Florida Title, Registration and License fees are the result of a highly complicated formula. As a result, the amounts charged may only be estimates. If the amount of taxes and government fees identified on page 1 hereof is less than the correct amount, Customer shall be obligated to Dealer for such difference. If the amount charged exceeds the correct amount, Dealer shall refund to Customer the difference. Dealer's obligations and rights hereunder may be assigned as this Order shall inure to the benefit of Dealer, its successors and/or assigns. All paragraph headings set forth in this Order are intended for convenience only and shall not control or affect the meaning or construction of the provisions hereof. All remedies afforded in this Order shall be taken and construed as cumulative, that is, in addition to every other remedy provided therein or by law. The failure of Dealer to enforce at any time any of the provisions of this Order, or to exercise any option herein provided, or to require at any time performance by Customer of any of the provisions hereof, shall in no way be construed to be a waiver or create an estoppel from enforcement of such provisions, nor in any way to affect the validity of this Order or any part thereof, or the right of Dealer to thereafter enforce each and every such provision, or to seek relief as a result of the prior breach. This Order is an essential document to any claim by Customer against Dealer in connection with the leasing of the Vehicle.

H. Termination: In the event this Order is terminated by either Dealer or Customer as permitted by this Order, including, but not limited to the failure to obtain Lease Approvals: (a) Dealer will be entitled to the immediate return of the Vehicle and Customer shall be obligated to return the Vehicle to Dealer within 24 hours of the date of termination; and (b) Customer shall be liable to Dealer for \$1.00 per mile used over and above 25 miles per day average, plus any wear, tear or damage to the Vehicle and diminution in value. In the event that the Vehicle is not returned within this time period, such failure will constitute a material breach of this Order and Dealer shall have those remedies as described in paragraph "I" below. Otherwise, Customer will be entitled to the return of their inception money subject to a lien in favor of Dealer for any amount due it hereunder. If a Trade-In was applied towards the Vehicle's acquisition, it shall be returned to Customer upon payment of a reasonable charge for storage, lien payoffs and repairs (if any) or, if it has been already sold by Dealer, Customer shall be entitled to the "Net Trade-in Proceeds", calculated as follows: the ACV, less the sum of (i) liens, (ii) costs incurred by Dealer to repair and/or ready it for sale, and (iii) a selling commission equal to 15% of the ACV. If the Net Trade-In Proceeds is negative, then Customer shall be obligated to Dealer for that amount.

I. Dealer's Recourse: In the event this Order is breached by Customer, Dealer shall: (a) have the right to the immediate return of Vehicle and to repossess same, with or without legal action, and to peacefully enter onto any property in which Customer has an interest in order to effectuate such repossession; (b) be entitled to compensation for Customer's use of Vehicle equal to: (i) \$1.00 per mile used; and (ii) \$30.00 for each day Customer is in possession of Vehicle, unless the Vehicle's Cash Price exceeds \$20,000, then \$45.00 per day; (c) be entitled to compensation for any damage, including but not limited to unusual wear and tear to the Vehicle and repossession related charges, as well as detailing and restocking costs; (d) have a lien on any Trade-In or the Net Trade-In Proceeds, and any payments made by Customer hereunder; (e) have the right to attach and perfect a lien against the Vehicle or Trade-In for those amounts due it hereunder, and Customer hereby consents to and authorizes same for which authority Customer grants Dealer an irrevocable power of attorney to record that lien; and (f) be entitled to any other remedy available at law or equity. In the event Dealer repossesses the Vehicle, Customer shall hold Dealer harmless and indemnified from any liability, damages or consequential damages arising out of an authorized repossession, including any claims from third parties asserting an interest in personality left in Vehicle.

J. Servicing and Collection Contacts: You agree that we may try to contact you in writing, by e-mail, or using prerecorded/artificial voice messages, text messages, and automatic telephone dialing systems, as the law allows. You also agree that we may try to contact you in these and other ways at any address or telephone number you provide us, even if the telephone number is a cell phone number or the contact results in a charge to you.





BBB AUTO LINE

MANUFACTURER RESPONSE FORM

Case Number:	██████████	Start Date:	9/03/20
Customer Name:	██████████	State:	Florida
VIN:	██████████	Probable Hearing Location:	N/A

This claim is IN Warranty OUT of Warranty
 Has the customer contacted you regarding the claim? YES NO
 Is the VIN listed above correct? YES NO

SETTLEMENT INFORMATION

What, if anything, are you willing to offer the customer to settle this dispute? Please include as much detail as possible (e.g., dealership name for repairs, specific dollar figures, etc.).

General Motors does not have any current offers.

Has this offer been communicated to the customer? YES NO

ARBITRATION INFORMATION

Please list customer requests that you feel are ineligible for arbitration and explain why.

We do not believe Mr. ██████████ 2019 Cadillac XT6 meets the criteria of Florida Lemon Law, or the General Motors Program Summary. There has been no significant loss of use, value or safety of their vehicle.

Please write your position as to the cause of each problem listed on the *Customer Claim Form*.

All of the concerns that Mr. ██████████ has brought to the attention of the dealer in regards to their 2019 Cadillac XT6 for radio failure, USB connection failure and reverse camera failure which all have been addressed. If there are any current concerns on the vehicle we request that Mr. ██████████ make the vehicle available for repairs per the terms of the manufacturer's written warranty.

Please indicate the decision you request the arbitrator to render:

We respectfully ask that Mr. ██████████ request for repurchase of their 2019 Cadillac XT6 be denied and that Mr. ██████████ continue to work with General Motors per the terms of our written warranty coverage.

List the amount of any over allowance/negative equity: \$ 0.00

GM will participate By phone In person In writing

Return this form as soon as possible

To: Completed by: ██████████' Date: 9/9/20

BBB AUTO LINE Future contact: Same as above

Fax: 703.247.9700 Phone: 800-231-1841 ext:5912441 Fax (866) 215-6750

MRF

Mileage Deductions			
Mileage Deductions for Miles to Dealership			
FROM: ██████████, Sarasota, FL ██████████			
TO: Sunset Cadillac of Sarasota, 2200 Bee Ridge Rd, Sarasota, FL 34239			
Miles to dealer from customer's residence (one way)		3.6 miles	
Round trip miles to dealer		7.2 miles	
6 visits to dealer (6 x 7.2)		Miles to Dealer Total	43.2 miles
Mileage Deduction for Miles dealer used vehicle			
Invoice Date	Invoice #	Mileage	Miles Dealer Put On
01/23/20	██████████	745 -746	1
03/04/20 - 03/06/20	██████████	1,546 -1,547	1
03/06/20 - 03/12/20	██████████	1,546 - 1,550	4
05/26/20 - 05/27/20	██████████	2,751	0
07/20/20	██████████	3,215	0
07/29/20 - 07/30/20	██████████	4,047 - 4,049	2
Total Miles Dealer Used Vehicle			8
Miles to Dealer Total			43.2 miles
Total Miles Dealer Used Vehicle			8
Total miles to deduct			59.2

Current Mileage = 4,496 – 22 miles at time of purchase = 4,474 miles

4,474 miles – 59.2 miles deduction= 4,415

4,415/120,000 x \$55,391.44 (Agreed Upon Value) = \$2,037.94 Usage Fee

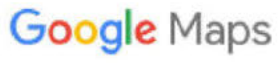

[Redacted] Sarasota, FL [Redacted] to Sunset Cadillac Of Sarasota

Drive 3.6 miles, 11 min

Miles to dealer

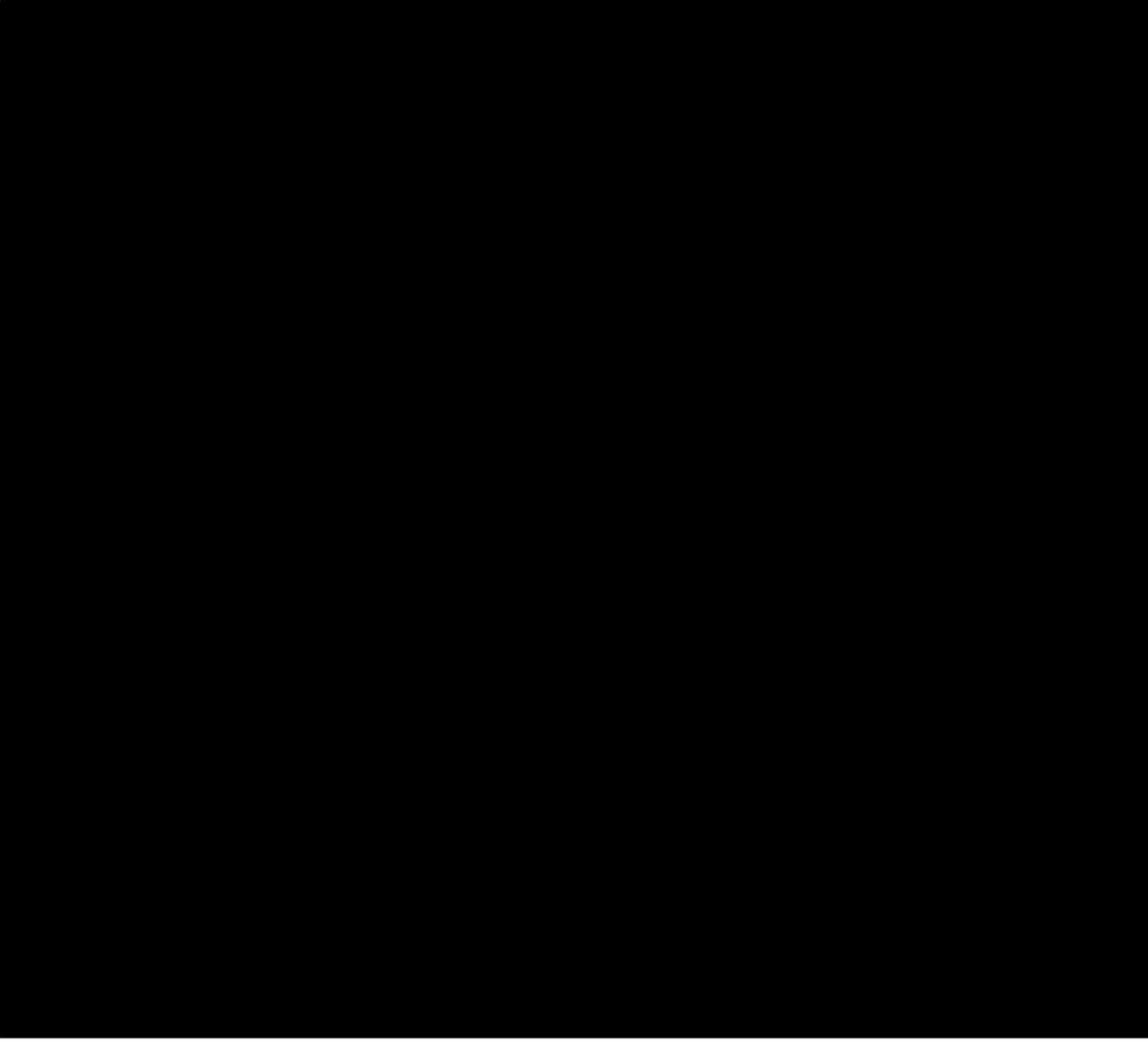

Explore Sunset Cadillac Of Sarasota



Groceries



Hotels



Gas stations



Parking Lots



More



Service Request: [REDACTED]
Customer Last Name: [REDACTED]
VIN: [REDACTED]
Vehicle: 2020 Cadillac XT6

This is an urgent request for documentation needed to defend General Motors at arbitration. Pending documentation is imperative to the defense of this case. Please provide the following documentation:

1. Is the vehicle currently at the dealer? *yes*
2. Is there an open RO currently for vehicle? *if so how long has vehicle been at dealer *yes* *8/11/20*
R.O# [REDACTED]
3. Copy of Open RO if any *see attachment* ←
4. Could you provide a picture of the vehicle and VIN# *see attached*
5. Could you provide a picture of current mileage *see attached*
6. Rental/Loaner (DRAC) Paperwork (needs to show date in/out) *see attached*
 - RO [REDACTED] *see attached*

Please provide the needed information within 24 hours. Please provide documentation by email to penny.crisp@gm.com. Your cooperation in this matter is greatly appreciated as we are under strict timelines to respond to this matter.

Sincerely,

Penny Crisp
Arbitration Specialist
General Motors - Business Resource Center
Phone: 866-790-5600 x5911368
penny.crisp@gm.com

Nothing in this message is intended to constitute an electronic signature unless a specific statement to the contrary is included in this message.

Confidentiality Note: This message is intended only for the person or entity to which it is addressed. It may contain confidential and/or privileged material. Any review, transmission, dissemination or other use, or taking of any action in reliance upon this message by persons or entities other than the intended recipient is prohibited and may be unlawful. If you received this message in error, please contact the sender and delete it from your computer.

[REDACTED]

9/17/2020

FW: Urgent action Required for BBB Case#: [REDACTED]

Customer: [REDACTED] SR# [REDACTED] VIN#:
[REDACTED]

Steve Montanaro

Thu 9/17/2020 12:12 PM

To: Chris Sorensen <csorensen@sunsetautogroup.com>;

Cc: Jim Carson <jcarson@sunsetautogroup.com>;

Importance: High

Hi Chris,

Not sure if Jim forwarded this, but can you assist?

Thanks,

Steve Montanaro

General Manager

941-922-1571 Office

SunsetCadillacSarasota.com

PremierCollisionSarasota.com

Sunset Cadillac of Sarasota

Premier Collision of Sarasota

2200 Bee Ridge Rd.

Sarasota, FL 34239

2019 Cadillac Dealer of the Year

From: Penny Crisp (C) <penny.crisp@gm.com>

Sent: Thursday, September 17, 2020 12:11 PM

To: Steve Montanaro <smontanaro@sunsetautogroup.com>; Jim Carson <jcarson@sunsetautogroup.com>

Cc: Darryl Turner <darryl.turner@cadillac.com>; Yolanda C. Hatten <yolanda.c.hatten@cadillac.com>

Subject: Urgent action Required for BBB Case#: [REDACTED] Customer: [REDACTED] SR# 9-6230496807, VIN#:
[REDACTED]

Importance: High

ATTN:

Sunset Cadillac Of Sarasota

BAC#: [REDACTED]

[REDACTED] 9/17/2020

623784

023704

SUNSET CADILLAC OF SARASOTA

A SUNSET AUTOMOTIVE GROUP COMPANY

2200 Bee Ridge Road • SARASOTA, FLORIDA 34239
Telephone: (941) 922-1571
923-1849



www.sunsetautogroup.com
State of Florida Registration: MV-09603

217

STATE REG# MV9603

161618 903310

ALL PARTS ARE NEW UNLESS OTHERWISE INDICATED.
SEE BACK FOR ADDITIONAL CUSTOMER INFORMATION REGARDING REPAIRS

RECOMMENDED SERVICES

OPERATION	OPERATION DESCRIPTION	MO / MI	TOTAL
03CDZZ28	ROTATE AND BALANCE	MO	
98CDZ10CDZZ05	21000 MILE SERVICE	MI	
10CDZZ13	BG DIFF FLUSH	MI	
98CDZ10CDZZ25	EMISSION SERVICE	MI	
10CDZZ15	BG 4WD SERVICE	MI	
98CDZ88CDZZ01	LUBE OIL AND FILTER	MI	
98CDZ95CDZZ01	LUBE OIL AND FILTER	MI	
98CDZ95CDZZ03	ROTATE AND BALANCE	MI	
98CDZ95CDZZ07	TIRE ROTATION	MO	
98CDZ95CDZZ08	BALANCE WHEELS/TIRES	MO	

PLEASE READ CAREFULLY, CHECK ONE OF THE STATEMENTS BELOW, AND SIGN: I UNDERSTAND THAT UNDER STATE LAW, I AM ENTITLED TO A WRITTEN ESTIMATE, IF MY FINAL BILL WILL EXCEED \$100.00.

I REQUEST A WRITTEN ESTIMATE.
 I DO NOT REQUEST A WRITTEN ESTIMATE AS LONG AS THE REPAIR COSTS DO NOT EXCEED \$_____. THE SHOP MAY NOT EXCEED THIS AMOUNT WITHOUT MY WRITTEN OR ORAL APPROVAL.

WRITTEN ESTIMATE.

DATE 8/11/20

DATE	REPAIR ORDER	MILEAGE	ADVISOR	TECHNICIAN	TYPE	OPERATION	OPERATION DESCRIPTION
07/29/20		4047	790	217	W	01CDZ2262	PREM CARE OIL CHANGE
				217	W	17CDZ001	RADIO
				217	W	17CDZ-004	ELECTRICAL DIAG 2
				217	W	01CDZ2263	CAD PREMIUM CARE T/R
				217	W	01CDZ	*MULTI-POINT INSP
07/21/20		3215	813	813	C	81CDZZ-MICRO	MICRO FIBER CLOTH

SERVICE

SALESPERSON NO. 918 ALEJANDRO A RODRIGUE

VEHICLE ID NO.	YEAR / MAKE / MODEL	STOCK NO.	LICENSE NO.	R.O. NO.
	20/CADILLAC/XT6/PREMIUM LUXURY	30081		
CUSTOMER NO.	SERVICE CONTRACT	DELIVERY DATE	DELIVERY MILES	SELLING DEALER NO.
		12/09/19	22	
COLOR	CONTRACT NO.	EXPIRATION DATE	EXPIRATION MILES	TAG NO.
CRYST WHITE TRI/C				
TURBO	M/MC	AIR COND.	P.S.	TRANS
N	CDZZ	Y	Y	A
				MILEAGE
				4,451
			ADVISOR NO.	PRODUCTION DATE
			790	

RESIDENCE OR CELL PHONE: [REDACTED]
 TIME RECEIVED: 07:53am
 LABOR RATE: [REDACTED]
 BUSINESS OR CELL PHONE: [REDACTED]
 DATE/TIME PROMISED: 08/11/20 06:00pm
 PRIORITY: 2

AUTHORIZATION: I, THE CUSTOMER HEREBY AUTHORIZE THE REPAIR WORK TO BE DONE, ALONG WITH THE USE AND APPLICATION OF ANY NECESSARY MATERIALS, AND AGREE THAT YOU, THE REPAIR SHOP, ARE NOT RESPONSIBLE FOR LOSS OR DAMAGE TO ANY OTHER CAUSE BEYOND YOUR CONTROL OR FOR ANY DELAYS CAUSED BY UNAVAILABILITY OF PARTS OR DELAYS IN PARTS SHIPMENTS BY THE SUPPLIER OR TRANSPORTER. THIS REPAIR SHOP IS ALSO NOT RESPONSIBLE FOR THEFT OF THE VEHICLE OR THEFT OF ANY ARTICLES STOLEN FROM INSIDE OR ON THE VEHICLE OR ANY DAMAGE CAUSED BY FIRE OR ANY ACTS OF NATURE. I HEREBY GRANT YOU AND/OR YOUR EMPLOYEES PERMISSION TO OPERATE THE VEHICLE ON STREETS, HIGHWAYS, OR ELSEWHERE, FOR THE PURPOSE OF TESTING AND/OR INSPECTION. AN EXPRESS MECHANIC'S LIEN IS ACKNOWLEDGED ON THIS VEHICLE TO SECURE THE AMOUNT OF THESE REPAIRS. ALL PARTS ARE NEW OR REMANUFACTURED UNLESS OTHERWISE INDICATED. ESTIMATES ARE GOOD FOR 30 DAYS. I ALSO AUTHORIZE ALL THE LISTED WORK TO BE PERFORMED ON MY VEHICLE FROM THE FRONT OF THIS DOCUMENT. I HAVE READ AND UNDERSTAND THE TERMS AND CONDITIONS OF THIS DOCUMENT.

APPOINTMENT Yes No
ADVISOR: RODNEY KIMPTON

SIGNED: [REDACTED]

LABOR INSTRUCTIONS

COMMENTS: CUSTOMER REQUESTED A LOANER created 2020-08-01 09:29:00am taken by Rodney Kimpton

1 W * 17CDZ-004 ELECTRICAL DIAG 2
C/S: back up camera will not work at times [REDACTED]
HAS RED LINE THRU CAMERA.

2 W * 01CDZ *MULTI-POINT INSP
PLEASE PERFORM MULTI-POINT INSPECTION

3 W * 17CDZ CHASSIS ELECTRICAL
CUSTOMER STATES WHILE DRIVING SCREEN GOES COMPLETELY BLANK.
HAS AUDIO BUT SCREEN IS BLANK.

ORIGINAL ESTIMATE \$			
DATE			
TIME			
ADDITIONAL AUTHORIZED AMOUNT \$			
ADD'L REPAIRS AUTHORIZED BY			
REVISED AUTHORIZED ESTIMATE \$			
AUTHORIZATION RECEIVED BY			
NAME AND SIGNATURE OF OTHER PERSON WHO MAY REQUEST ADD'L REPAIRS			
CHARGE FOR ESTIMATE \$			
DESCRIPTION OF ADD'L WORK AUTHORIZED			
IF THE CHARGE FOR PREPARING AN ESTIMATE CANNOT BE DETERMINED THE CHARGE WILL BE BASED ON 1 HOURLY PLAT RATE EACH			
METHOD OF PAYMENT	RENTAL CAR	Y	N
<input type="checkbox"/> CASH	<input type="checkbox"/> CAR	<input type="checkbox"/>	<input type="checkbox"/>
<input type="checkbox"/> CHECK	<input type="checkbox"/> SAVE PARTS	<input type="checkbox"/>	<input type="checkbox"/>
<input type="checkbox"/> VISA	<input type="checkbox"/> BODY SHOP	<input type="checkbox"/>	<input type="checkbox"/>
<input type="checkbox"/> MAS. CARD	<input type="checkbox"/>	<input type="checkbox"/>	<input type="checkbox"/>
<input type="checkbox"/> AM. EXP.	<input type="checkbox"/>	<input type="checkbox"/>	<input type="checkbox"/>
BASIS FOR CHARGE	WAITING	<input type="checkbox"/>	<input type="checkbox"/>
<input type="checkbox"/> PLAT RATE	<input type="checkbox"/>	<input type="checkbox"/>	<input type="checkbox"/>
<input type="checkbox"/> HRLY RATE	CALL WHEN READY	<input type="checkbox"/>	<input type="checkbox"/>
<input type="checkbox"/> BOTH	<input type="checkbox"/>	<input type="checkbox"/>	<input type="checkbox"/>

Handwritten notes: 9:30 AM 8/12/20, 9:20 AM, C/S USA Part, Does not connect to iPhone, order # 229 pers

SF611764 Q (03/17)
Reynolds Company ERAINTWOLE C0732210 Q (05/15)

2200 BEE RIDGE RD.SARASOTA.FL.34239. 922-1571

CUSTOMER INFORMATION				VEHICLE INFORMATION	
Customer		Unit# 30281		RA# FF58149B	
Home Address		Service Advisor Rod Kimpton		PO	
City	Zip	Date and time OUT Aug 11th 2020, 08:14:44 AM	Date and time IN		
Driver's License No.	Expires	Date and time DUE IN 08/18/2020	Vehicle VIN		
Birth Date	AS ADDITIONAL DRIVERS. HAVE SIGNED BY CUSTOMER.		License No.		State
Additional Driver's Name		Birth Date	Year	Make	
Driver's License No.	State	Expires	Model	Color	
Additional Driver's Name		Birth Date	Tag #		
Driver's License No.	State	Expires	Miles Allowed		
CUSTOMER INSURANCE INFORMATION				Mileage OUT	
Insurer	Policy No.	Expiration Date		Mileage IN	
Agent		Telephone		Miles Driven	
Insured Vehicle Year/Make/Model/Color		State		Chargeable Miles	
2020/Cadillac/XT6				FUEL	
License No.				OUT	32.9% (6 gal)
				IN	
<input type="checkbox"/> PERMISSION TO TOW TRAILER WITH LOAD CAPACITY IN EXCESS OF 2,000 POUNDS; NOT TO EXCEED MANUFACTURER'S WEIGHT SPECIFICATIONS.				RATES DO NOT INCLUDE FUEL CHARGES	
You are required to return the Vehicle with at least the same amount of fuel as when rented. If you do not return the Vehicle with at least the same amount of fuel; you will pay us a refueling fee of \$ _____ plus fuel @ \$ _____ per gallon.				HOURS: _____ @ \$ _____ PER HOUR	
Unless otherwise noted, any daily rate is based on a 24-hour period.				DAYS: _____ @ \$ _____	
The valid and collectible liability insurance and personal injury protection insurance of any authorized rental or leasing driver is primary for the limits of liability and personal injury protection coverage required by §§ 324.021(7) and 627.736, Florida Statutes.				WEEKS: _____ @ \$ _____	
Failure to return rented property or equipment upon expiration of the rental period and failure to pay all amounts due (including costs for damage to the property or equipment) are evidence of abandonment or refusal to redeliver the property, punishable in accordance with Section _____				MILES: _____ @ _____ PER MILE	
The following are "Prohibited Uses": Use by an unauthorized driver; smoking, vaping or use of tobacco products in the Vehicle; use of the Vehicle by anyone under the influence of alcohol or prescription or non-prescription drugs; and carrying persons or property for hire or providing transportation network company or other transportation services. See Paragraph 6 of the Terms and Conditions for other Prohibited Uses and additional information.				TOTAL TIME & MILEAGE CHARGES →	
By signing below, you agree to the terms and conditions of this Agreement set forth on this Face Page, the Vehicle Condition Report, and all pages of the Vehicle Use Terms and Conditions; acknowledge that you had an opportunity to read the entire Agreement before signing; authorize us to process a separate payment card voucher in your name for all Charges, including Tolls and Violations and to release your billing/rental information to third parties for billing/processing and other legitimate purposes; permit us to reserve against your payment card the amount noted in the Charges column; agree that binding consideration exists, as further described in Section 2 of the Terms and Conditions; and authorize us to debit your payment card account to reflect changes to the charges.				TAXABLE FUEL _____ GAL @ \$ _____	
ALL CHARGES SUBJECT TO FINAL AUDIT				NET DUE CUSTOMER DEPOSIT / REFUND / OTHER	
				SUB-TOTAL	
				TOTAL CHARGE →	
				METHOD OF PAYMENT	
				<input type="checkbox"/> CHECK <input checked="" type="checkbox"/> AMEX <input type="checkbox"/> MC <input type="checkbox"/> VISA <input type="checkbox"/> OTHER	
				\$ _____	
				REFUNDED \$ _____	
				08 / 2024 EXPIRES	
				CUSTOMER INITIALS X _____	
				# *****1009	
				<input type="checkbox"/> CARD VERIFIED	

Customer is still in this vehicle...

[Handwritten signature]

SUNSET CADILLAC
OF SARASOTA
A SUNSET AUTOMOTIVE GROUP COMPANY



2200 BEE RIDGE ROAD • SARASOTA, FLORIDA 34239
www.sunsetautogroup.com
STATE OF FLORIDA REGISTRATION: MV-09603
HOURS: 7:30 A.M. - 5:30 P.M. MONDAY-FRIDAY

CADILLAC SALES
(941) 922-1571

CADILLAC SERVICE
(941) 923-1849

CELL: [REDACTED]

CUSTOMER NO [REDACTED]	ADVISOR RODNEY KIMPTON	790	TAG NO 4869	INVOICE DATE 03/17/20	INVOICE NO [REDACTED]
[REDACTED]	LABOR RATE	LICENSE NO	MILEAGE 1,546	COLOR CRYST WHITE	STOCK NO. 30081
[REDACTED]	YEAR / MAKE / MODEL 20/CADILLAC/XT6/PREMIUM LUXURY			DELIVERY DATE 12/09/19	DELIVERY MILES 22
SARASOTA, FL [REDACTED]	VEHICLE ID NO [REDACTED]			SELLING DEALER NO.	PRODUCTION DATE
[REDACTED] YAHOO.COM	P. I. NO.	P. O. NO.	I. O. DATE 03/06/20		
COMMENTS					MO [REDACTED]

LABOR & PARTS
JOB # 1 17CDZ CHASSIS ELECTRICAL HOURS: 2.30 TECH(S):217 310.52

TECH#	DATE	START	FINISH	ACT	TIME	DESCRIPTION
217	03/09/20	15.70	16.60	0.90	0.00	HOLD OTHER
217	03/10/20	8.00	10.30	1.80	0.00	HOLD OTHER
217	03/11/20	8.40	8.70	0.30	0.00	HOLD OTHER
217	03/11/20	14.40	14.40	0.00	0.00	FINISHED
217	03/13/20	0.00	0.00	0.00	2.30	OVERRIDE IN INVOICING
TOTAL TECH TIME				3.00	2.30	

CUSTOMER STATES REAR VIEW CAMERA IS NOT WORKING.
GETTING RED SYMBOL ON SCREEN.
GDS DIAG RADIO DTC B395A-08, B395A-3A AND B395A-72. TAC
CASE [REDACTED] DIAG WITH THE EL-52552 VIDEO TEST KIT.
VPCM TEST GOOD. REAR CAMERA TEST GOOD. ADVISED TO REPLACE
RADIO AND PROGRAM SPS AND PROGRAM USB PORTION OF RADIO.
REPLACED RADIO AND PROGRAMMED SPS. PROGRAM USB PORTION OF
RADIO. TESTED SEVERAL TIMES.

E.M. PAID

JOB # 1 TOTAL LABOR & PARTS 310.52

MISC-----CODE-----	DESCRIPTION-----	CONTROL NO-----	
JOB # 1	ADME ADMIN ELECTRONICS		45.00
TOTAL - MISC			45.00

COMMENTS-----
LOANER

R/O TAX	0.00
R/O TOTALS	355.52

WARRANTY CLAIM DETAIL TOTALS-----

CLAIM#.....	TOTAL....
619729-1	355.52
CLAIM TOTALS	355.52

APPROVED BY SIGNATURE _____

ALL PARTS ARE NEW UNLESS OTHERWISE INDICATED.

I ACKNOWLEDGE AND APPROVE OF ALL WORK PERFORMED, INCLUDING ANY ADDITIONAL WORK THAT MAY HAVE BEEN ADDED ON THE ORIGINAL WORK ORDER. I ACKNOWLEDGE RECEIPT OF A COPY OF THIS INVOICE AND I HAVE REVIEWED THE TERMS AND CONDITIONS LISTED ON THE REVERSE SIDE OF THIS PAGE.

CUSTOMER SIGNATURE X _____
The Reynolds and Reynolds Company ERANT76E SF611758 Q (0317)

SUNSET CADILLAC
OF SARASOTA
A SUNSET AUTOMOTIVE GROUP COMPANY



2200 BEE RIDGE ROAD • SARASOTA, FLORIDA 34239
www.sunsetautogroup.com
STATE OF FLORIDA REGISTRATION: MV-09603
HOURS: 7:30 A.M. - 5:30 P.M. MONDAY-FRIDAY

CADILLAC SALES

922-1571

CADILLAC SERVICE

923-1849

CELL: [REDACTED]

CUSTOMER NO	ADVISOR	TAG NO	INVOICE DATE	STOCK NO
[REDACTED]	RODNEY KIMPTON	790 4869	03/17/20	30081
LABOR RATE	LICENSE NO	MILEAGE	COLOR	DELIVERY MILES
[REDACTED]	[REDACTED]	1,546	CRYST WHITE	22
YEAR / MAKE / MODEL	DELIVERY DATE	SELLING DEALER NO	PRODUCTION DATE	
20/CADILLAC/XT6/PREMIUM LUXURY	12/09/19	[REDACTED]	[REDACTED]	
VEHICLE ID NO	F.T.E. NO.	P.O. NO.	F.I.O. DATE	
[REDACTED]	[REDACTED]	[REDACTED]	03/06/20	
RESIDENCE PHONE	BUSINESS PHONE	COMMENTS	MO: [REDACTED]	
[REDACTED]	[REDACTED]	[REDACTED]		

DCS AUDIT SLIP

JOB CARD 619729

VIN	[REDACTED]	REPAIRING BAC	119054
ODOMETER INDICATOR	M	JOB CARD OPEN DATE	03/06/2020
ODOMETER	1546	SERVICE ADVISOR GMIN	535413547
NON-GM VEHICLE	N	FOREIGN TOURIST	
REFERENCE NUMBER			

JOB	PAY TYPE	TRANS TYPE	CATEGORY	ERA CLAIM#	OE# SAP TRAN.#	VER
1	W	ZREG		619729-1		

JOB COMPLETION DATE: 03/13/2020
TECHNICIAN GMIN: 195771210

LABOR OPERATION	BASE HOURS	DIAGNOSIS
3420840	1.3	1.0

OTHER LABOR OPS (Y/N) N

COMPLAINT CODE: 0290

COMPLAINT DESCRIPTION: CUSTOMER STATES REAR VIEW CAMERA IS NOT WORKING. GETTING RED SYMBOL ON SCREEN.

CAUSE CODE: 6581

CAUSE DESCRIPTION: GDS DIAG RADIO DTC B395A-08, B395A-3A AND B395A-72. TAC CASE 9-5851883116. DIAG WITH THE EL-S2552 VIDEO TEST KIT. VPCM TEST GOOD. OD. REAR CAMERA TEST GOOD. ADVISED TO REPLACE RADIO AND PROGRAM SPS AND PR D PROGRAM USB PORTION OF RADIO.

CORRECTION DESCRIPTION: REPLACED RADIO AND PROGRAMMED SPS. PROGRAM USB PORTION OF RADIO. TESTED SEVERAL TIMES.

NET AMOUNT	CODE	INVOICE NO.	DISTANCE	RENTAL VIN OR INFO	DAYS	REASON
45.00	NIA					

WAIVE DEDUCTIBLE (Y/N) N

	TOTAL W/O TAX	TAX	TOTAL
PARTS HANDLING	0.00		
PARTS	0.00	0.00	0.00
LABOR	310.52	0.00	310.52
NET ITEMS	45.00	0.00	45.00
PARTICIPATION AMOUNT			(0.00)
TRANSACTION	355.52	0.00	355.52

ALL PARTS ARE NEW UNLESS OTHERWISE INDICATED.

I ACKNOWLEDGE AND APPROVE OF ALL WORK PERFORMED, INCLUDING ANY ADDITIONAL WORK THAT MAY HAVE BEEN ADDED ON THE ORIGINAL WORK ORDER. I ACKNOWLEDGE RECEIPT OF A COPY OF THIS INVOICE AND I HAVE REVIEWED THE TERMS AND CONDITIONS LISTED ON THE REVERSE SIDE OF THIS PAGE.

CUSTOMER SIGNATURE X

The Reynolds and Reynolds Company BRANTRIVE SF611758 Q (03/17)

SUNSET CADILLAC
OF SARASOTA
A SUNSET AUTOMOTIVE GROUP COMPANY



2200 BEE RIDGE ROAD • SARASOTA, FLORIDA 34239
www.sunsetautogroup.com

STATE OF FLORIDA REGISTRATION: MV-09603

HOURS: 7:30 A.M. - 5:30 P.M. MONDAY-FRIDAY
8:00 A.M. - 3:00 P.M. SATURDAY

CADILLAC SALES

922-1571

CADILLAC SERVICE

923-1849

CELL: [REDACTED]

CUSTOMER NO [REDACTED]	ADVISOR RODNEY KIMPTON	TAG NO 790 4869	INVOICE DATE 03/12/20	INVOICE NO CDCS619729
[REDACTED]	LABOR RATE	LICENSE NO	MILEAGE 1,546	COLOR CRYST WHITE
[REDACTED]	YEAR / MAKE / MODEL 20/CADILLAC/XT6/PREMIUM LUXURY	DELIVERY DATE 12/09/19	STOCK NO. 30081	DELIVERY MILES 22
SARASOTA, FL [REDACTED]	VEHICLE ID NO [REDACTED]	SELLING DEALER NO	PRODUCTION DATE	
[REDACTED] YAHOO.COM	F.T.E. NO	F.O. NO	F.I.D. DATE 03/06/20	
[REDACTED]	COMMENTS			MO: 1550

LABOR & PARTS
J# 1 17CDZ CHASSIS ELECTRICAL TECH(S):217 WARRANTY

CUSTOMER STATES REAR VIEW CAMERA IS NOT WORKING.
GETTING RED SYMBOL ON SCREEN.
GDS DIAG RADIO DTC B395A-08, B395A-3A AND B395A-72. TAC
CASE [REDACTED] DIAG WITH THE EL-52552 VIDEO TEST KIT.
VPCM TEST GOOD. REAR CAMERA TEST GOOD. ADVISED TO REPLACE
RADIO AND PROGRAM SPS AND PROGRAM USB PORTION OF RADIO.
REPLACED RADIO AND PROGRAMMED SPS. PROGRAM USB PORTION OF
RADIO. TESTED SEVERAL TIMES.

JOB # 1 TOTAL LABOR & PARTS 0.00

COMMENTS-----
LOANER

TOTALS-----

"This charge represents costs and profits to the motor vehicle repair facility for miscellaneous shop supplies or waste disposal." [s.559.904(4)]	TOTAL LABOR....	0.00
"The State of Florida requires a \$1.00 fee to be collected for each new tire sold in the state [s.403.718], and a \$1.50 fee to be collected for each new or remanufactured battery sold in the state [s.403.7185]."	TOTAL PARTS....	0.00
*****	TOTAL SUBLET....	0.00
YOU MAY SOON BE RECEIVING A SURVEY FROM GENERAL MOTORS CUSTOMER RELATIONS. THIS SURVEY IS OUR REPORT CARD. IF FOR ANY REASON YOU CANNOT ANSWER THE QUESTIONS AS *COMPLETELY SATISFIED* OR *EXCELLENT SERVICE*, PLEASE CONTACT JIM CARSON AT 941-922-1571.	TOTAL G.O.G....	0.00
	TOTAL MISC CHG.	0.00
	TOTAL MISC DISC	0.00
	TOTAL TAX.....	0.00
	TOTAL INVOICE \$	0.00

METHOD OF PAYMENT (CASH) (CHECK) (AM/DC VISA) (DISC) (AM EXP)
[REDACTED]

CUSTOMER SIGNATURE

ALL PARTS ARE NEW UNLESS OTHERWISE INDICATED.

I ACKNOWLEDGE AND APPROVE OF ALL WORK PERFORMED, INCLUDING ANY ADDITIONAL WORK THAT MAY HAVE BEEN ADDED ON THE ORIGINAL WORK ORDER. I ACKNOWLEDGE RECEIPT OF A COPY OF THIS INVOICE AND I HAVE REVIEWED THE TERMS AND REVERSE SIDE

CUSTOMER SIGNATURE

SUNSET CADILLAC OF SARASOTA

A SUNSET AUTOMOTIVE GROUP COMPANY

2200 Bee Ridge Road • SARASOTA, FLORIDA 34239
Telephone: (941) 922-1571
(941) 923-1849

www.sunsetautogroup.com
State of Florida Registration: MV-09603



SERVICE HISTORY

CELL: 941-300-0007

DATE	REPAIR ORDER	MI/AGE	ADVISOR	TECHNICIAN	TYPE	OPERATION	OPERATION DESCRIPTION
01/23/20	618114	745	790	217	W	17CDZ002	ELECTRICAL DIAG
				217	W	17CDZ	CHASSIS ELECTRICAL
				217	W	01CDZ	*MULTI-POINT INSP
12/06/19	616457	22	862	233	I	52CDZ02	NEW CAR DELIVERY
11/29/19	616150	2	230	217	W	77CDZZ-XT6	XT6 PDI
				217	W	81CDZ	NEW CAR ACCESSORIES

SERVICE

SALESPERSON NO. 918 ALEJANDRO A RODRIGUE

YEAR / MAKE / MODEL 20/CADILLAC/XT6/PREMIUM LUXURY		SICCK NO. 30081	LICENSE NO.	R.O NO 619729
CUSTOMER NO.	SERVICE CONTRACT	DELIVERY DATE 12/09/19	DELIVERY MILES 22	SELLING DEALER NO. 03/06/20
COLOR CRYST WHITE TRI/C		CONTRACT NO.	EXPIRATION DATE	EXPIRATION MILES
TURBO CDZZ	AIR COND. P. S.	TRANS A	MI/AGE 1,546	ADVISOR NO. 790
PRODUCTION DATE		TAG NO. 4869		

SALESPERSON: [REDACTED] YAHOO.COM

TIME RECEIVED: 02:04pm

LABOR RATE: [REDACTED]

PRIORITY: 2

APPOINTMENT: Yes No

ADVISOR: RODNEY KIMPTON

SIGNED: [REDACTED]

AUTHORIZATION: I, THE CUSTOMER, HEREBY AUTHORIZE THE REPAIR WORK TO BE DONE, ALONG WITH THE USE AND APPLICATION OF ANY NECESSARY MATERIALS, AND AGREE THAT YOU THE REPAIR SHOP ARE NOT RESPONSIBLE FOR LOSS OR DAMAGE TO ANY OTHER DAMAGE BEYOND YOUR CONTROL OR FOR ANY DELAYS CAUSED BY UNAVAILABILITY OF PARTS OR DELAYS IN PARTS SHIPMENTS BY THE SUPPLIER OR TRANSPORTER. THIS REPAIR SHOP IS ALSO NOT RESPONSIBLE FOR THEFT OF THE VEHICLE OR THEFT OF ANY ARTICLES STOLEN FROM INSIDE OR ON THE VEHICLE OR ANY DAMAGE CAUSED BY FIRE OR ANY ACTS OF NATURE. HEREBY GRANT YOU AND/OR YOUR EMPLOYEES PERMISSION TO OPERATE THE VEHICLE ON STREETS, HIGHWAYS, OR ELSEWHERE, FOR THE PURPOSE OF TESTING AND/OR INSPECTION. AN EXPRESS MECHANIC'S LIEN IS ACKNOWLEDGED AND INDICATED, ES OF THIS DOCUMENT.

STATE REG# MV9603

ALL PARTS ARE NEW UNLESS OTHERWISE INDICATED.

SEE BACK FOR ADDITIONAL CUSTOMER INFORMATION REGARDING REPAIRS

RECOMMENDED SERVICES

OPERATION	OPERATION DESCRIPTION	MI	HI	TOTAL
98CDZ10CDZZ05	21000 MILE SERVICE	MI		
10CDZZ13	BG DIFF FLUSH	MI		
10CDZZ15	BG 4WD SERVICE	MI		
98CDZ88CDZZ01	LUBE OIL AND FILTER	MI		
98CDZ95CDZZ01	LUBE OIL AND FILTER	MI		
98CDZ95CDZZ03	ROTATE AND BALANCE	MI		
10CDZZ14	BG REAR DIFF FLUSH	MI		

COMMENTS:

LOANER [REDACTED]

1 W * 17CDZ CHASSIS ELECTRICAL
CUSTOMER STATES REAR VIEW CAMERA IS NOT WORKING.
GETTING RED SYMBOL ON SCREEN.

Order # [REDACTED]

ORIGINAL ESTIMATE	5
DATE	
TIME	
ADDITIONAL AUTHORIZED	
REPAIRS AUTHORIZED BY	
DATE	
TIME	
RECEPTION RECEIVED BY	
DATE	
TIME	
DESCRIPTION OF WORK DONE	
ADVISOR	
METHOD OF PAYMENT	
RETAIL CAR	<input type="checkbox"/>
HOME	<input type="checkbox"/>
PARTS	<input type="checkbox"/>
BODY SHOP	<input type="checkbox"/>
BASE FOR CHARGE	
FLAT RATE	<input type="checkbox"/>
HRV RATE	<input type="checkbox"/>
BOTH	<input type="checkbox"/>
WRITE IN	
YES	<input type="checkbox"/>
NO	<input type="checkbox"/>

SF011764 C (03/17) The Reynolds and Reynolds Company, 2015-2016

PLEASE READ CAREFULLY, CHECK ONE OF THE STATEMENTS BELOW, AND SIGN: I UNDERSTAND THAT UNDER STATE LAW, I AM ENTITLED TO A WRITTEN ESTIMATE, IF MY FINAL BILL WILL EXCEED \$100.00.

I REQUEST A WRITTEN ESTIMATE.

I DO NOT REQUEST A WRITTEN ESTIMATE AS LONG AS THE REPAIR COSTS DO NOT EXCEED \$100.00. THE SHOP MAY NOT EXCEED THIS AMOUNT WITHOUT MY WRITTEN OR ORAL APPROVAL.

SIGN: [REDACTED]

Looks? okay Radio DTC B395A-08
B395A-34 & B395A-72

[REDACTED], okay with the
EL-52552 Video test kit VPCN test board
New Camera test good, contact Trc, was
Advised to Regl. Radio & Program SPS
& Program USB portion of Radio Stand test
Several Times

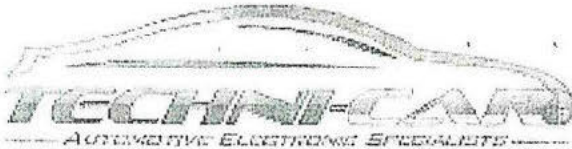

450 Commerce Blvd. PH: (800) 886-0022
 Oldsmar, FL 34677 FAX: (813) 855-2101
 www.techni-car.com csr@techni-car.com

Sales Order



**** This is not an invoice ****

General Information:		
Part Ordered 84791505	Part In Vehicle 84791505	Dealer Contact ROD
Purchase Order #	Date Ordered 03/06/20	Status Shipped
Shipped Via FedEx Overnight	Tracking # [REDACTED]	Web Order # [REDACTED]

Vehicle Information:			
VIN [REDACTED]	Odometer Reading 1546	Odo Type Miles	Delivery Date 12/09/19
Repair Order # [REDACTED]	RO Date 03/06/20		Axle Ratio
TCI to program? No	Vehicle Requires SEO Programming? No	Service Engine Hours .000000	Tire Size

Customer Information:	
[REDACTED]	

Handwritten: \$443.19 x 92.61% = 410.44

Warranty Information:	
Warranty Status: Recheck	Recheck -- Previous RO Number
Complaint REAR VIEW CAMERA NOT WORKING	

Additional Information:





Global Diagnostic System 2

Vehicle DTC Information

Overview

Vehicle Identification Number (VIN) XXXXXXXXXX
 Report Creation Date 2020-03-06 15:18:08 EST

Vehicle Configuration Property

Make	Cadillac
Model	XT6
Model Year	2020
Rear Differential Clutch Control Module Version	0501
Instrument Cluster Version	Enhanced Multi-Color Driver Information Center (UHS)
Telematics Communication Interface Control Module Version	11 (Telematics Communications Platform, 4 Connectors)
Transmission Type	Automatic Transmission 9 Speed (M3W)
Seat Memory Control Module Version	063A
Engine Identifier	3.6L (LGX)

System Information Property

VCI Serial Number MDI 2: 88727481
 Vehicle Session Creation Date 2020-01-23 12:49:36
 Test Start Time 2020-03-06 15:16:45 EST

Control Module Name	Control Module Status	DTC Count	DLC Pin
Engine Control Module	No DTCs Stored	0	6,14
Transmission Control Module	No DTCs Stored	0	6,14
Electronic Brake Control Module	No DTCs Stored	0	6,14
Brake System Control Module	No Communication	0	6,14
Power Steering Control Module	No DTCs Stored	0	6,14



Suspension Control Module	No Communication	0	12,13
Body Control Module	No DTCs Stored	0	6,14
Serial Data Gateway Module - Processor 1	No DTCs Stored	0	6,14
Serial Data Gateway Module - Processor 2	No DTCs Stored	0	1
Inflatable Restraint Sensing and Diagnostic Module	No DTCs Stored	0	1
Passenger Presence Module	No DTCs Stored	0	1
Seat Belt Retractor Motor Module - Left	No Communication	0	12,13
Seat Belt Retractor Motor Module - Right	No Communication	0	12,13
Instrument Cluster	No DTCs Stored	0	1
Night Vision Camera Control Module	No Communication	0	3,11
Radio Controls	No DTCs Stored	0	1
HVAC Controls	No DTCs Stored	0	1
Video Processing Control Module	No DTCs Stored	0	1
Headlamp Control Module	No DTCs Stored	0	6,14
Trailer Lighting Control Module	No Communication	0	1
Radio	DTCs Stored	3	6,14
Amplifier	No DTCs Stored	0	1
Infotainment Control Switch	No DTCs Stored	0	1
Telematics Communication Interface Control Module	No DTCs Stored	0	6,14
HVAC Control Module	No DTCs Stored	0	1
Liftgate Control Module	No DTCs Stored	0	1
Seat Memory Control Module - Driver	No DTCs Stored	0	1
Keyless Entry Control Module	No DTCs Stored	0	1
Side Object Sensor Module - Left	No DTCs Stored	0	1
Side Object Sensor Module - Right	No DTCs Stored	0	1
Parking Assist Control Module	No DTCs Stored	0	1
Frontview Camera - Windshield	No DTCs Stored	0	6,14
Steering Column Lock Control Module	No DTCs Stored	0	1
Power Supply Transformer	No Communication	0	6,14
Forward Range Radar Sensor - Long Range	No Communication	0	3,11
Short Range Radar Sensor - Left Front	No Communication	0	3,11
Short Range Radar Sensor - Right Front	No Communication	0	3,11
Short Range Radar Sensor - Rear Middle	No Communication	0	3,11
Rear Drive Control Module	No Communication	0	6,14

Control Module	Type	DTC Display	Symptom Byte	DTC Description	Symptom Description	Status
Radio		B395A	08	Rearview Camera	Performance - Signal Invalid	History



					DTC Current Status	Not Current
					DTC History Status	History
					History	
Radio	B395A	3A	Rearview Camera	Incorrect Component Installed	DTC Current Status	Not Current
					DTC History Status	History
					History	
Radio	B395A	72	Rearview Camera	Message Counter Incorrect	DTC Current Status	Not Current
					DTC History Status	History



Print

CASE INFORMATION

Owning Advisor: [REDACTED] Warner
 Advisor Phone: 877-426-8227
 Status: Open
 Created On: 03/04/2020
 Close Date:
 Initiated By:

CUSTOMER ISSUE/CONCERN

Primary Issue: NO REAR CAMERA / AND NO 350 CAMERAS
 DTC Codes: B395A SYM08 B399B SYM05 VIDEO PROCE

VEHICLE INFORMATION

Repair Order: 619601
 Vehicle: 2020 Cadillac XT6
 VIN: [REDACTED]
 Mileage: 1,546
 Warranty Status:
 Warranty Start: 12/9/2019 12:00:00 AM
 Patrick Allshouse

Type	Sub-Type	Status	Owner	Date Created	Completed	Comments
Dealer Communication	Information Only	✓ Done	[REDACTED]	03/11/2020	03/11/2020	Thank you for using DCM. We want to make:
Follow-Up		✓ Done	[REDACTED]	03/11/2020	03/11/2020	yes the dics from vpc and camera are no f-
Dealer Communication	Information Only	✓ Done	[REDACTED]	03/11/2020	03/11/2020	Greetings Patrick: Thanks for the update, pr
Follow-Up		✓ Done	[REDACTED]	03/11/2020	03/11/2020	pls all cameras work only at times do we get
Follow-Up		✓ Done	[REDACTED]	03/11/2020	03/11/2020	YES WE DID USE THE EL-2552 TEST KIT ACCO
Dealer Communication	Action Required	✓ Done	[REDACTED]	03/11/2020	03/11/2020	Greetings Patrick: Did you use the test cox
Follow-Up		✓ Done	[REDACTED]	03/11/2020	03/11/2020	AFTER REPLACING THE VPCM AND CAMERA
TAC Inbound Call	Diagnostics	✓ Done	[REDACTED]	03/05/2020	03/05/2020	Additional information provided on the call:
Dealer Communication	Information Only	✓ Done	[REDACTED]	03/04/2020	03/04/2020	Greetings: Patrick Based on the information:
Dealer Communication	Case Creation	✓ Done	[REDACTED]	03/04/2020	03/04/2020	Times In: 2 Days Down, 1 Customer Owned:

Action Complete

Radio - Programming (A11)
2020-03-10 08:11:15 -04:00

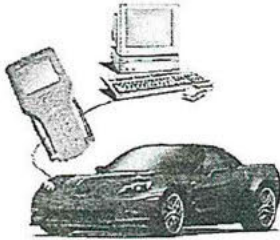

Job Card: 619729

Warranty Claim Code: [REDACTED]

Record this code on the warranty repair order (if applicable).

Important Notes/Remarks:

The Warranty Claim code is required to confirm programming has been completed. Incorrect or missing Warranty Claim Codes may result in rejection of warranty claim.

Warranty claim codes for prior VINS serviced may be retrieved through "Settings" at SPS start page.

Follow the Controller Specific Instructions below.

If there are no Controller Specific Instructions, turn ignition off for 30 seconds to reset the controller.

Mandatory Controller Specific Instructions (to be respected):

Clearing DTCs will erase stored history data from all controllers on the Data Link Connector currently in use. Move your interface to any additional Auxiliary Data Connectors on the vehicle to clear DTCs from other controllers. When finished, return the interface to the Data Link Connector.

Print

VIN: [REDACTED]

Clear DTCs Proceed with same VIN New Cancel

Action Complete

Radio - USB File Transfer (A11)

2020-03-10 09:36:41 -04:00

Job Card: 619729

Warranty Claim Code: [REDACTED]

Record this code on the warranty repair order (if applicable).

Important Notes/Remarks:

The Warranty Claim code is a required to confirm programming has been completed. Incorrect or missing Warranty Claim Codes may result in rejection of warranty claim.

Warranty claim codes for prior VINS service may be retrieved through "Settings" at SIS start page.

Follow the Controller Specific Instructions below.

If there are no Controller Specific Instructions, turn ignition off for 30 seconds to reset the controller.

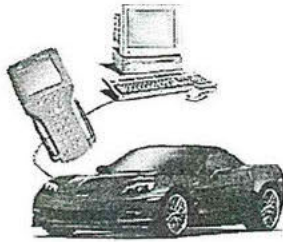

Mandatory Controller Specific Instructions (to be respected):

Clearing DTCs will erase stored history data from all controllers on the Data Link Connector currently in use. Move your interface to any additional Auxiliary Data Connectors on the vehicle to clear DTCs from other controllers. When finished, return the interface to the Data Link Connector.

Print

VIN: [REDACTED]
Clear DTCs Proceed with same VIN Now Cancel

■■■■ i would like to file a complaint, 2020 cadillac XT 6, camera will not function and dealer said they can not get replacement parts, 10 Sep. 2020 , 06:11pm

hi

Cadillac Bot, 10 Sep. 2020 , 06:11pm

Thanks! In order to best assist, please provide your first and last name.

[Read]

■■■■ i would like to file a complaint, 2020 cadillac XT 6, camera will not function and dealer said they can not get replacement parts, 10 Sep. 2020 , 06:13pm

■■■■ i would like to file a complaint, 2020 cadillac XT 6, camera will not function and dealer said they can not get replacement parts

Cadillac Bot, 10 Sep. 2020 , 06:13pm

[Rich Content]

[Read]

■■■■ i would like to file a complaint, 2020 cadillac XT 6, camera will not function and dealer said they can not get replacement parts, 10 Sep. 2020 , 06:13pm

Assistance on a vehicle I own

Cadillac Bot, 10 Sep. 2020 , 06:13pm

[Rich Content]

[Read]

■■■■ i would like to file a complaint, 2020 cadillac XT 6, camera will not function and dealer said they can not get replacement parts, 10 Sep. 2020 , 06:13pm

Phone Pairing / Navigation / Radio

Cadillac Bot, 10 Sep. 2020 , 06:14pm

Attempting to connect you to an advisor...

[Read]

██████████ 10 Sep. 2020 , 06:15pm

Hi Mr. ██████████ Thanks for contacting the OnStar and Connected Services Chat team. My name is Lyn. How can I assist you today?

[Read]

██████████ ██████████ i would like to file a complaint, 2020 cadillac XT 6, camera will not function and dealer said they can not get replacement parts, 10 Sep. 2020 , 06:16pm

I don't want onstar, I need to file a maintenance complaint

██████████ 10 Sep. 2020 , 06:17pm

Sorry. Thank you for chatting with Cadillac Customer Assistance Center Chat My name is Lyn. How can I assist you today?

[Read]

██████████ ██████████ i would like to file a complaint, 2020 cadillac XT 6, camera will not function and dealer said they can not get replacement parts, 10 Sep. 2020 , 06:18pm

██████████ ██████████ i would like to file a complaint, 2020 cadillac XT 6, camera will not function and dealer said they can not get replacement parts

██████████ 10 Sep. 2020 , 06:20pm

I understand your complaint for vehicle's Camera. Thank you for your feedback, we will make sure the appropriate information is documented.

I will be documenting your concerns on your account, however, issues or concerns with Dealer workmanship or personnel need to be handled directly by the dealer. You will need to reach out to the dealership management or dealer legal staff for further assistance.

[Read]

██████████ 10 Sep. 2020 , 06:21pm

May I know what is the current issue with the camera in your vehicle?

[Read]

██████████ i would like to file a complaint, 2020 cadillac XT 6, camera will not function and dealer said they can not get replacement parts, 10 Sep. 2020 , 06:22pm

I did reach out to the dealer, they can't help me, I need to file a complaint with Cadillac LLC. to try to get some action

██████████ i would like to file a complaint, 2020 cadillac XT 6, camera will not function and dealer said they can not get replacement parts, 10 Sep. 2020 , 06:22pm

the camera will not work

██████████ 10 Sep. 2020 , 06:23pm

I am terribly sorry for any inconvenience this may have caused you and for the current vehicle concerns you have been experiencing. Thank you for bringing these concerns to our attention so that we may help you work towards a solution! Let me see what we can do to get this issue resolved. Could I please have your VIN or current mileage?

[Read]

██████████ i would like to file a complaint, 2020 cadillac XT 6, camera will not function and dealer said they can not get replacement parts, 10 Sep. 2020 , 06:23pm

All camera, blank screen

██████████ 10 Sep. 2020 , 06:24pm

I'm sorry to know that. May I have your VIN and current mileage?

[Read]

██████████ i would like to file a complaint, 2020 cadillac XT 6, camera will not function and dealer said they can not get replacement parts, 10 Sep. 2020 , 06:24pm

I do not need you to keep apologizing, I need to file a complaint

■■■■ i would like to file a complaint, 2020 cadillac XT 6, camera will not function and dealer said they can not get replacement parts, 10 Sep. 2020 , 06:25pm

it will take a bit to get the vin #

■■■■ 10 Sep. 2020 , 06:26pm

I completely understand. We need to gather more information to document your concern and we will look for the best resolution.

[Read]

■■■■ 10 Sep. 2020 , 06:26pm

Thank you.

[Read]

■■■■ i would like to file a complaint, 2020 cadillac XT 6, camera will not function and dealer said they can not get replacement parts, 10 Sep. 2020 , 06:27pm

I am getting the vin don't let this session stop, hold on about 2, 3 minutes

■■■■ 10 Sep. 2020 , 06:27pm

Thank you.

[Read]

■■■■ i would like to file a complaint, 2020 cadillac XT 6, camera will not function and dealer said they can not get replacement parts, 10 Sep. 2020 , 06:31pm

vin #■■■■■■■■■■ MILES 3,745

■■■■ 10 Sep. 2020 , 06:32pm

Thank you. While I'm looking into this for you, can you please verify your phone number, email address and complete mailing address for documentation purposes?

[Read]

[REDACTED] i would like to file a complaint, 2020 cadillac XT 6, camera will not function and dealer said they can not get replacement parts, 10 Sep. 2020 , 06:34pm

[REDACTED]

[REDACTED] i would like to file a complaint, 2020 cadillac XT 6, camera will not function and dealer said they can not get replacement parts, 10 Sep. 2020 , 06:35pm

[REDACTED] Zanesville, Ohio [REDACTED] [REDACTED]

[REDACTED] i would like to file a complaint, 2020 cadillac XT 6, camera will not function and dealer said they can not get replacement parts, 10 Sep. 2020 , 06:36pm

Ohio

[REDACTED] 10 Sep. 2020 , 06:37pm

I appreciate you confirming all of this information for me. May I have the name of the dealership that you are currently working with?

[Read]

[REDACTED] i would like to file a complaint, 2020 cadillac XT 6, camera will not function and dealer said they can not get replacement parts, 10 Sep. 2020 , 06:42pm

Jeff Drennen Cadillac,Chevrolet, Buick, GMC. 3625 Maple Ave, Zanesville Ohio, 43701

[REDACTED] i would like to file a complaint, 2020 cadillac XT 6, camera will not function and dealer said they can not get replacement parts, 10 Sep. 2020 , 06:43pm

[REDACTED]

[REDACTED] 10 Sep. 2020 , 06:44pm

Thank you. May I know the dealership's diagnosis in your vehicle and why they could not get a replacement for all the parts needed for your vehicle?

[Read]

██████████ i would like to file a complaint, 2020 cadillac XT 6, camera will not function and dealer said they can not get replacement parts, 10 Sep. 2020 , 06:48pm

Raido module, they put a new radio in it and that was not the problem, now they have diagnosed it to be the module, Cadillac will have to tell us why we can not get replacement parts?

██████████ i would like to file a complaint, 2020 cadillac XT 6, camera will not function and dealer said they can not get replacement parts, 10 Sep. 2020 , 06:49pm

new car, paid a lot of money for it, and not can not use it.

██████████ 10 Sep. 2020 , 06:51pm

Thank you for that information.

[Read]

██████████ 10 Sep. 2020 , 06:54pm

Please give em 3 to 5 minutes to look for the best solution.

[Read]

██████████ 10 Sep. 2020 , 06:57pm

I appreciate your patience and thank you so much for holding.

[Read]

██████████ 10 Sep. 2020 , 06:57pm

Mr. ██████████ I would suggest to speak with the Customer Experience Manager for any assistance at the dealership. We work in direct partnership with the Customer Experience Managers at our dealers.

The Customer Experience Manager is a proactive advocate for you, working to resolve any concerns you may have. The Customer Experience Manager is there to provide support, guidance, and a resolution to your concerns, by being your main point of contact and a liaison within the dealership. They have many resources and contacts available to them to address and resolve your concerns in a timely manner.

You may speak with John Bebout. The Customer Manager at the dealership. You may call him at phone number (740) 452-4579.

I have created a case for you so that Cadillac can be made aware of this situation. Your reference number is [REDACTED]

[Read]

[REDACTED] 10 Sep. 2020 , 06:59pm

Is there anything else I can help you with?

[Read]

[REDACTED] 10 Sep. 2020 , 07:00pm

Thank you for contacting Cadillac Customer Assistance Center. Please feel free to contact us if assistance is needed in the future.

[Read]

Hertz RAC 2020 Cadillac XT6 - [REDACTED]

Equipped with RPO's:

IOS - CADILLAC USER EXPERIENCE 8" DIAGONAL COLOR DISPLAY.

UVB - HD REAR VISION CAMERA.

P17 Information Display Screen Flashes OFF/ON, *only* when in reverse.

Tucson, AZ / Dealer BAC - 259758

TAC Case [REDACTED]

Current Mileage - 4,975 miles



To date, dealer had replaced the B87 Rearview Camera and the A11 (IOS) Radio & installed a test coax cable between, concern persisted.
No DTC's setting. FSE visited dealer 9/30/20. Verified concern was present as described.

Found RVC Image flashed off/on *ONLY* when shifted into reverse.
Once shifted into drive, RVC image remains steady for a few seconds until it changes over to the radio screen.
(Video of concern)

Radio Power, Ground and Serial Data

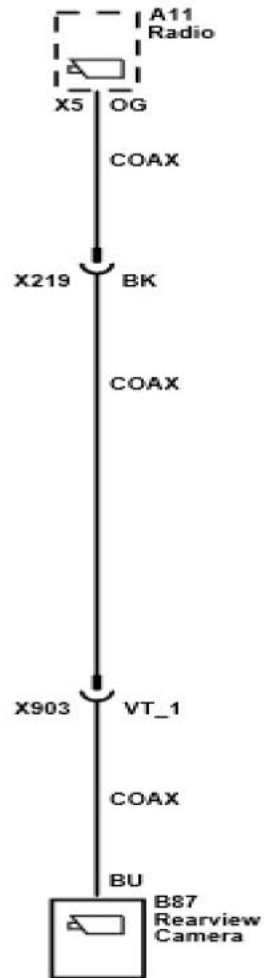

UVB RVC System is a very simple ckt. All components shown had already been replaced, yet concern persisted?

Suspecting possible aftermarket lighting, Dealer had severed the Back-Up Lamp Control ckt 24 at the A11 Radio connector X2, terminal 13, which should have eliminate any possible aftermarket lighting concerns?

RVC Image still activated when shifted into reverse???

Screen flashing on/off concern persisted.

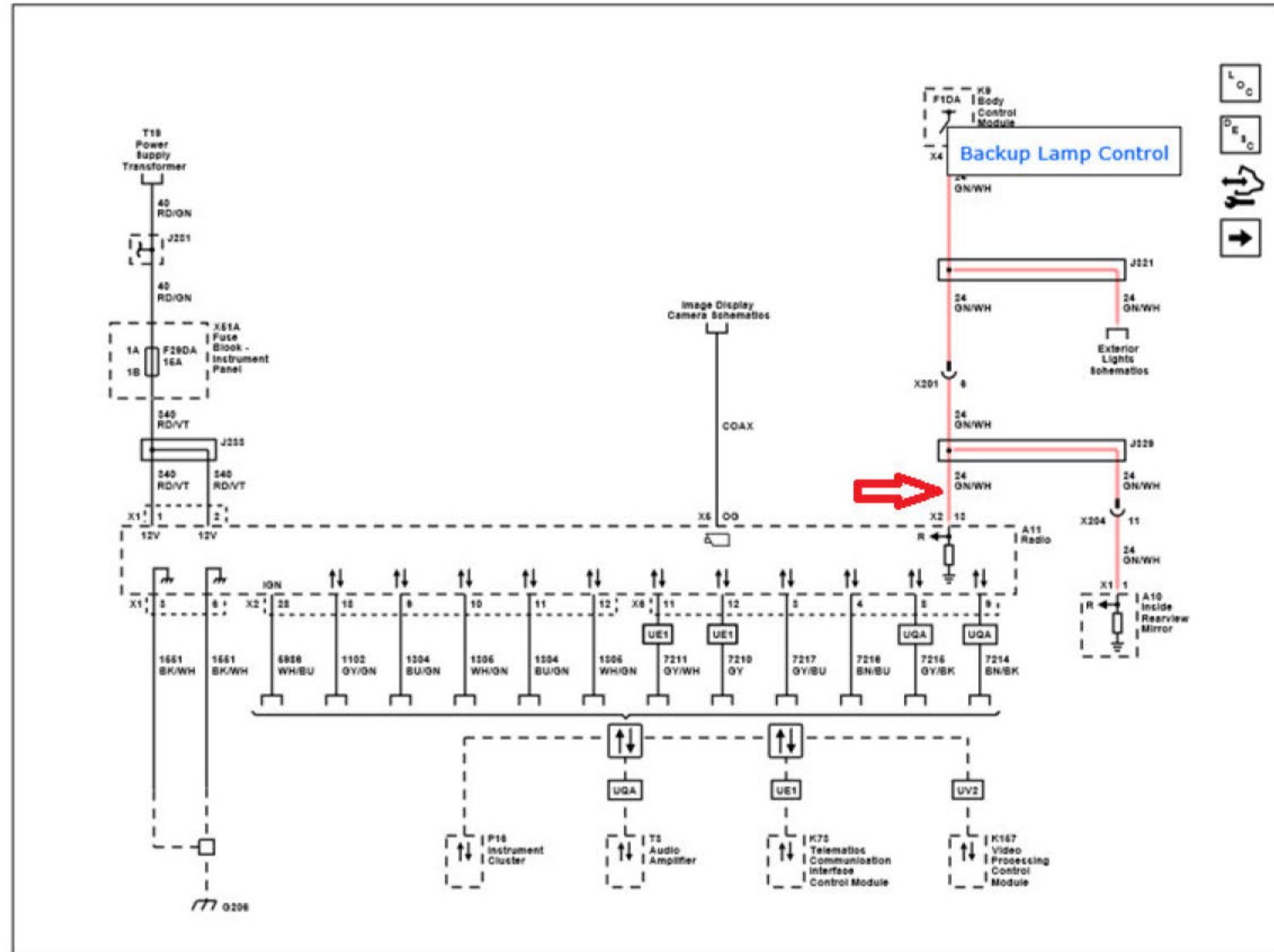

There is obviously some other input letting the radio know when vehicle is in reverse, (suspect over GM LAN Communication?)

Only other possibilities inducing the concern could be incorrect Hardware/Software installed previously?

Possible faulty LVDS Cable, or faulty P17 Info Display Module?

But why would either of these components cause the concern to occur only while in reverse?

We verified O.E. A11 Radio P/N 84817042, Replacement Radio P/N 84857381 & Replacement B87 RVC P/N 84721404 were all correct for the vehicle application.



Verified IOS A11 radio had been correctly SPS programmed with correct calibrations.
A11 Radio had latest software version U150 installed.

Programming System

Summary

Controller	Id	Current #	Selected #	Description
2	84627923	84627923		Radio
3	84517309	84517309		Hybrid
4	84848432	84848432		New calibrations to prevent audio and navigation prompts from being played d
5	84758477	84758477		Language
6	84627926	84627926		Speech Recognition
7	84627927	84627927		Hands-Free Tuning
8	84758470	84758470		Rear View Camera
9	84627931	84627931		Common
10	84517388	84517388		HVAC
11	84719545	84719545		Telematics
12	84627934	84627934		Optional Equipment Calibration 1
13	84517412	84517412		Optional Equipment Calibration 2
14	84517418	84517418		Optional Equipment Calibration 3
15	84719538	84719538		Equalizer

Service Programming
E6787: Yo
This is not

Vehicle Data

Attribute

For RPO J0810T80U uplevel radio

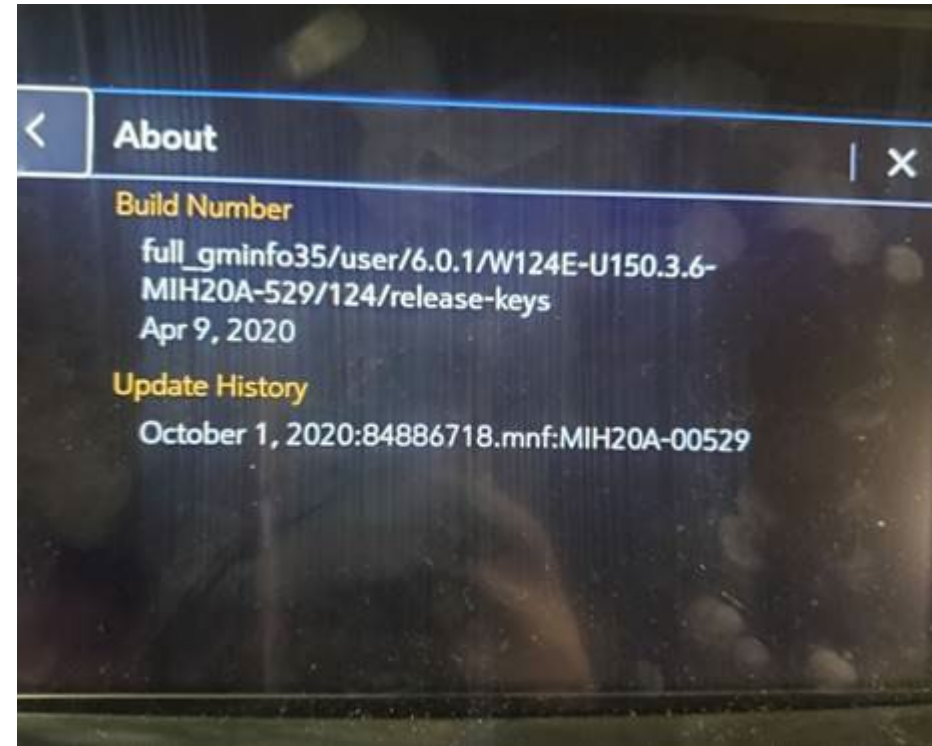

EPC lists the Molex LVDS Cable as being serviced by I/P Harness replacement only.
(SI Doc ID 5182682)

Display Power, Ground, Serial Data and Microphones (IOS or IOT)

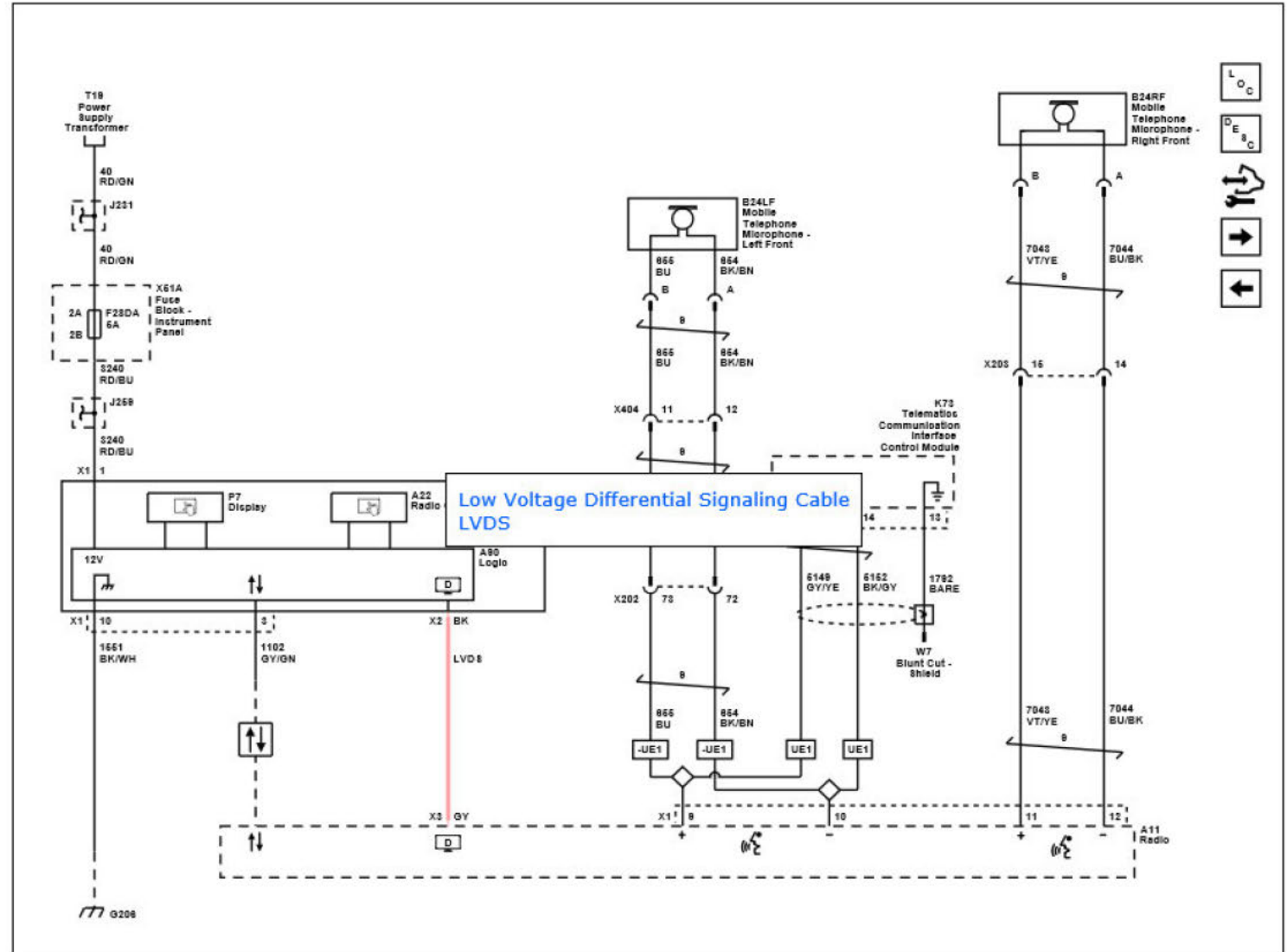

With few options left, we decided to try replacing the P17 Info Display Module.
(Label off O.E. P17 Info Display Module - P/N 84752892)

After replacing the P17 Info Display Module, the RVC Image no longer flashed off/on,
image remained on steady while in reverse and operated normally.



While I did find a few similar 2019 cases for P17 Info Display Module Screen Flashing On/Off in the Siebel Data Base,
 None were listed as only occurring while in reverse?
 None were for an IOS Radio & none were for a 2020 Model Year N8 / C1TL Platform Vehicle.

Replaced The P17 Info Display Module	Radio	Infotainment	Display - Image Quality	radio goes black and flashes on and off	D2UC	RADIO	DISPLAY	PERFORMANCE	Infotainment	IOR	X6	XV	2019
Replaced The P17 Info Display Module	Radio	Infotainment	Display - Image Quality	radio display flashes on/off	D2UC	RADIO	DISPLAY	FLASH	Infotainment	IOT	X4	XP	2019
Replaced The P17 Info Display Module	Radio	Infotainment	Display - Other Issues	radio screen blank with lines flashing in the middle of t...	C1YB	RADIO	DISPLAY	INOPERATIVE	Infotainment	I05 (NGI)	V1	VA	2019
Replaced The P17 Info Display Module	Radio	Infotainment	Display - Inoperative	radio flashing on off	D2UC	DISPLAY	FLICKER		Infotainment	IOT	X6	XX	2019

I suspect one of the 3 LVDS ckts is dedicated for RVC and something in the P17 Info Display Module
 was just not interpreting the signal correctly?
 Unknown if all these platforms & Infotainment systems utilize the same P17 Info Display Module?

[A11 Radio X3](#)

Connector Part Information

- Harness Type: Instrument Panel
- OEM Connector: 111146-7101
- Service Connector: Service by Cable Assembly - See Part Catalog
- Description: 12-Way M 2.0 HSAL-2 Series (GY)

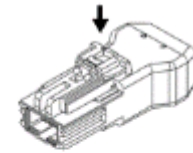
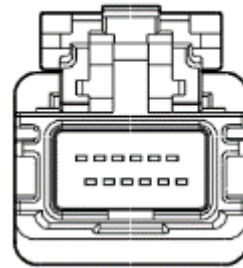

This investigation document contains the first fifty pages. You may request the full version through NHTSA.ODI.CED@dot.gov. Requests are answered as resources allow and in the order they are received.

A11 Radio X3

Pin	Size	Color	Circuit	Function	Terminal Type ID	Option
1	0.01	BARE	4813	Human Machine Interface LVDS (Low Voltage Differential Signaling) Low Reference	I	IOS/IOT
2	0.01	BU	4814	Human Machine Interface LVDS (Low Voltage Differential Signaling) Signal [+]	I	IOS/IOT
3	0.01	WH	4815	Human Machine Interface LVDS (Low Voltage Differential Signaling) Signal [-]	I	IOS/IOT