

This file represents a consolidation of multiple files sent by the manufacturer. Please use the bookmarks to navigate to each file. (Each bookmark label is the name of the original file.)

This file represents a consolidation of multiple files sent by the manufacturer. Please use the bookmarks to navigate to each file. (Each bookmark label is the name of the original file.)



# STAR Case

---

**Case Number: S1314000009**

**Release Date: 06/16/2015**

## Symptom/Vehicle Issue:

Some customers may experience a no start condition, engine stops running or poor idle condition

## Diagnosis:

If the customer experiences the symptom/condition proceed to the repair procedure below.

## Repair Procedure:

1. Inspect the fuel Injectors, both fuel rails, all high pressure fuel pipes and the high pressure fuel pump for presence of metal debris. To inspect the high pressure pump for debris it's recommended removing the fuel pressure regulator valve.
2. Was metal debris found at any component?
  - a. Yes >>> Proceed to Step #3
  - b. No >>> Further diagnosis required.
3. Replace the high pressure fuel pump, both fuel rails, all injectors and all pipes between the high pressure fuel pump and the injectors.

Note: Regardless of Market Calibration NBC (Euro5) or NB4 (Euro 4), utilize the new NAS High Pressure Fuel Pump P/N 68211269AA as a replacement for the Failed High Pressure Fuel Pump.

4. Remove the fuel tank and flush the tank and both fuel lines (fuel supply and return line) because metal debris was spilled into the tank and both fuel lines.
5. Replace the fuel filter.

Perform all repairs by following the detailed service procedures found in DealerCONNECT / TechCONNECT < 14- Fuel System < Fuel Delivery.

This document does not authorize warranty repairs. This communication documents a record of past experiences. STAR Center Online does not provide any conclusions about what is wrong with the vehicle. Rather, it captures all previous cases known that appear to be similar or related to the vehicle symptom / condition. You are the expert, and you are responsible for deciding on the appropriate course of action.

# STAR Case



## Parts Required:

Qty.	Part No.	Description
1	Refer to Star Parts Catalogue	FILTER, Fuel/Water Separator
1		Rail, Fuel, Left
1		Rail, Fuel, Right
6		INJECTOR, Fuel
6		SEAL, Fuel Injector
1		<b>68211 269AA</b>
1	Refer to Star Parts Catalogue	TUBE KIT, Fuel Supply
1		TUBE, Fuel Return

## Verification:

Test drive vehicle and verify engine works properly

This document does not authorize warranty repairs. This communication documents a record of past experiences. STAR Center Online does not provide any conclusions about what is wrong with the vehicle. Rather, it captures all previous cases known that appear to be similar or related to the vehicle symptom / condition. You are the expert, and you are responsible for deciding on the appropriate course of action.

This file represents a consolidation of multiple files sent by the manufacturer. Please use the bookmarks to navigate to each file. (Each bookmark label is the name of the original file.)



**NUMBER:** 18-054-21 REV. A

**GROUP:** 18 - Vehicle Performance

**DATE:** December 21, 2021

*This bulletin is supplied as technical information only and is not an authorization for repair. No part of this publication may be reproduced, stored in a retrieval system, or transmitted, in any form or by any means, electronic, mechanical, photocopying, or otherwise, without written permission of FCA US LLC.*

**This bulletin supersedes Technical Service Bulletin (TSB) 18-054-21, date of issue June 09, 2021, which should be removed from your files. All revisions are highlighted with **\*\*asterisks\*\*** and include new part numbers, fuel pump replacement and LOP.**

**SUBJECT:**

Diesel Fuel Pump Failure and System Contamination

**OVERVIEW:**

This bulletin involves inspecting for fuel pump failure and fuel system contamination. Also fuel system cleaning and fuel system kit replacement.

**MODELS:**

2019 - 2020	(DD)	RAM 3500 Cab Chassis
2019 - 2020	(DP)	RAM 4500/5500 Cab Chassis
2019 - 2020	(D2)	RAM 3500 Pickup
2019 - 2020	(DJ)	RAM 2500 Pickup

**NOTE: This bulletin applies to vehicles within the following markets/countries: North America.**

**NOTE: This bulletin applies to vehicles equipped with a 6.7L I6 Cummins Turbo Diesel Engine (Sales Code ETN and ETL) or 6.7L I6 Cummins HO Turbo Diesel Engine (Sales Code ETM).**

**SYMPTOM/CONDITION:**

Customers may experience a Malfunction Indicator Lamp (MIL) illumination. Upon further investigation the technician may find that one or more of the following Diagnostic Trouble Codes (DTCs) have been set:

- P0087-00 - Fuel Rail Pressure Too Low.
- P008A-00 - Low Pressure Fuel System Pressure - Too Low.
- P0201-00 - Fuel Injector 1 Circuit/Open.
- P0202-00 - Fuel Injector 2 Circuit/Open.
- P0203-00 - Fuel Injector 3 Circuit/Open.
- P0204-00 - Fuel Injector 4 Circuit/Open.
- P0205-00 - Fuel Injector 5 Circuit/Open.
- P0206-00 - Fuel Injector 6 Circuit/Open.

The customer may also notice the following:

- Engine will not start.

**DIAGNOSIS:**

Using a Scan Tool (wiTECH) with the appropriate Diagnostic Procedures available in DealerCONNECT/Service Library, verify all related systems are functioning as designed. If DTCs or symptom conditions, other than the ones listed above are present, record the issues on the repair order and repair as necessary before proceeding further with this bulletin.

**NOTE: Foreign contaminants are typically not covered under warranty. Please be sure to follow all published warranty repair guidelines regarding repairs to fuel systems contaminated with foreign contaminants.**

If the customer describes the symptom/conditions listed above or if the technician finds the DTCs, perform the Inspection Procedure.

**INSPECTION:**

1. Remove the Fuel Quantity Solenoid (FQS) from the injection pump. Refer to Service Library Service Information Section: 14 - Fuel System / Fuel Delivery, Diesel / Solenoid, Fuel Quantity / Removal.
2. Inspect the FQS screen as well as the FQS bore for signs of metal contamination (Fig. 1) .
3. Was any signs of metal found?
  - YES>>> Proceed to [Step 4](#) of the Inspection Procedure.
  - NO>>> This service bulletin does not apply. Further diagnosis is required. Proceed to [Step 6](#) of the Inspection Procedure to reinstall the FQS.



Fig. 1

**Metal Contamination On The FQS And In The FQS Bore**

4. Take an appropriate fuel sample, and inspect for signs of foreign contaminants (e.g. DEF, gas, rust, dirt, or other foreign debris). Refer to Service Library, Service Information Section 14 - Fuel System > Fuel Delivery, Diesel > Standard Procedure > Diesel Fuel Contamination Testing Procedure.

**NOTE: Foreign contaminants are typically not covered under warranty. Please be sure to follow all published warranty repair guidelines regarding repairs to fuel systems contaminated with foreign contaminants.**

5. Were any foreign contaminants (e.g. DEF, gas, rust, dirt, or other foreign debris) found in the fuel sample?
  - YES>>> Please refer to all **warranty repair guidelines** before continuing with fuel system repair. Proceed to [Step 1](#) of the Repair Procedure.
  - NO>>> Proceed to [Step 1](#) of the Repair Procedure.
6. Install the Fuel Quantity Solenoid (FQS) from the injection pump. Refer to Service Library Service Information Section: 14 - Fuel System / Fuel Delivery, Diesel / Solenoid, Fuel Quantity / Installation.

**PARTS REQUIRED:**

**NOTE: Before ordering any Fuel System Kits make sure there are no parts restrictions. If there is a parts restriction, make sure to follow the instructions to order the kits.**

Qty.	Part No.	Description
**1 (A/R)	68579319AA	Pump, Fuel Upfit Kit (HO and SO)**
1 (A/R)	**R8583897AA**	Fuel System Kit (HO) (Sales Code ETM)
1 (A/R)	**R8583898AA**	Fuel System Kit (SO) (Sales Code ETN or ETL)

**Parts NOT Included In The Kit.**

**NOTE: Order In-Tank lift pump based on the parts catalog using the VIN**

Qty.	Part No.	Description
**1	05145571AA	Pump - In-Tank Module (Lift Pump) DJ/D2 28 Gallon (Sales Code NGC), 32 Gallon (Sales Code NFX) and 31 Gallon (Sales Code NFT)
1	68490266AA	Pump - In-Tank Module (Lift Pump) DJ/D2 50 Gallon (Sales Code NFC)
1	04560227AB	Pump - In-Tank Module (Lift Pump) DD/DP 22 Gallon (Sales Code NFA)
1	68084721AA	Pump - In-Tank Module (Lift Pump) DD/DP 52 Gallon (Sales Code NFH)
1	68002992AA	Washer, Banjo Bolt
1	68005162AA	Gasket CC**

**Parts Included In The Fuel System Repair Kit.**

<b>Qty.</b>	<b>Part No.</b>	<b>Description</b>
**6	R8444790AA	Injector - Fuel
1	68447760AA	Rail - Fuel
1	68479996AA	Line 1 - Fuel
1	68479997AA	Line 2 - Fuel
1	68479998AA	Line 3 - Fuel
1	68479999AA	Line 4 - Fuel
1	68480000AA	Line 5 - Fuel
1	68480003AA	Line 6 - Fuel
1	68417030AA	Connector - High Pressure Tube Kit (6 Tubes)
1	68157291AA	Filter - Fuel (Engine Mounted)
1	68436631AA	Filter - Fuel (Chassis Mounted)**

**\*\*Parts Included In The Fuel Pump Upfit Kit.**

<b>Qty.</b>	<b>Part No.</b>	<b>Description</b>
1	68573988AA	Pump - Fuel
1	68573990AA	Adapter - Pilot
1	68573989AA	Adapter Plate - Fuel Pump
1	68573991AA	Harness - Jumper
1	68573993AA	Support - Fuel Pump
1	68573994AA	Spacer - Threaded
1	68573995AA	Tube - Injector Fuel Supply
1	68573996AA	Tube - Fuel Supply
1	68573997AA	Tube - Fuel Drain
1	68573999AA	Plug - Rail
1	68574000AA	Bracket - ECM
1	68573998AA	Connector - Quick Disconnect
1	68578594AA	Mount - Swivel Tie
1	68359768AF	Hose - Power Steering
2	68578595AA	Bolt - Low Profile
2	4638665	Screw - Hex Flange Head
1	4429446	Screw - Hex Flange Head
2	68578596AA	Screw - Socket Head Cap
1	4429114	Screw - Hex Flange Head
1	4429630	Screw - Hex Flange Head
1	68444371AA	Seal - O-Ring
1	68086175AA	Washer - Spring

Qty.	Part No.	Description
1	68533229AA	Inlet - Quick Disconnect Fuel Pump
1	05086769AA	Nut - Hex
3	68038172AA	Tie - Wire
1	4429689	Nut **

### **REPAIR PROCEDURE:**

1. Remove the fuel tank. Refer to Service Library Service Information Section 14-Fuel System > Fuel Delivery, Diesel > Tank, Fuel > Removal.
2. Using appropriate storage and/or disposal methods, in accordance with your local regulations drain, and dispose of all of the contaminated fuel from the fuel tank.

**NOTE: Do not attempt to flush any of the fuel components (high or low pressure) using Brakleen™ or similar harsh solvent cleaners. This may cause damage to any internal coatings. For an effective repair, all high pressure fuel system components should be replaced.**

3. Thoroughly clean, and flush the fuel tank using fresh, clean, diesel fuel.

**NOTE: The In-tank fuel pump (lift pump) is not part of the Fuel System Kit and must be ordered separately based on the VIN.**

4. Replace the in-tank fuel pump module.

**NOTE: In some vehicle applications, leave the fuel tank partially installed to allow access to the fuel return line fitting.**

5. Reinstall the fuel tank, leaving the chassis fuel return line disconnected at the tank.
6. Fill the tank with 10 gallons of fresh fuel.
7. Remove the chassis mounted fuel filter element.
8. Place an appropriate catch basin under the fuel filter housing to capture all fuel expelled during the next steps.
9. Turn the ignition to run, and allow the in-tank fuel pump to run a complete cycle (approx. 15 seconds). Capture all of the fuel expelled from the filter housing.
10. Using wiTECH, navigate to the PCM "Actuators" tab, and perform the Lift Pump Relay routine to activate the in-tank fuel pump. This routine will run the pump for 20 seconds. Capture all fuel expelled from the fuel filter housing.
11. Repeat [Step 10](#), 2 additional times.
12. Install a new chassis mounted fuel filter element.
13. Place an appropriate catch basin under the engine mounted fuel filter housing to capture all fuel expelled during the next steps.
14. Open the drain valve, and drain the engine mounted fuel filter housing.
15. Remove the filter element. Leave the drain valve open at this time.
16. Thoroughly clean the filter housing bowl of all debris.
17. Using wiTECH, perform the Lift Pump Relay routine to activate the in-tank fuel pump. The fuel filter housing will begin to fill. If necessary, stop the routine before the housing begins to overflow.

18. Allow the housing to fully drain, and clean out any additional debris that is present.
19. Repeat [Step 16](#), [Step 17](#) and [Step 18](#), 2 additional times.
20. Install a new fuel filter element, and tighten the cap to specifications.
21. Close the fuel filter housing drain valve.
22. Disconnect the fuel supply hose from the high pressure fuel injection pump.
23. Connect a suitable hose to the fuel supply hose, and route it into a suitable container.
24. Using wiTECH, perform the Lift Pump Relay routine to activate the in-tank fuel pump for 1 complete cycle to flush any contaminants out of the supply line.
25. **\*\*Replace the High Pressure Fuel Injection Pump. The pump has been updated and requires additional steps to install. Please refer to the [High Pressure Fuel Injection Pump Installation procedure](#) in [Step 1](#) below.\*\***
26. Replace the High Pressure Fuel Rail. Refer to Service Library, Service Information Section 14-Fuel System > Fuel Delivery, Diesel > Rail, Fuel > Removal and Installation.
27. Replace all 6 fuel injectors, and injector connector tubes. Refer to Service Library, Service Information Section 09 – Engine, 6.7L Diesel > Fuel Injection > Injector(s), Fuel > Removal, and Installation.
28. Install new high pressure fuel rail to injector connector tube fuel lines.

**NOTE: \*\*Ensure that the provided fuel line isolators (PN 68447788AA) are properly secured onto the #3 and #4 fuel rail to injector connector tube fuel lines as shown.**

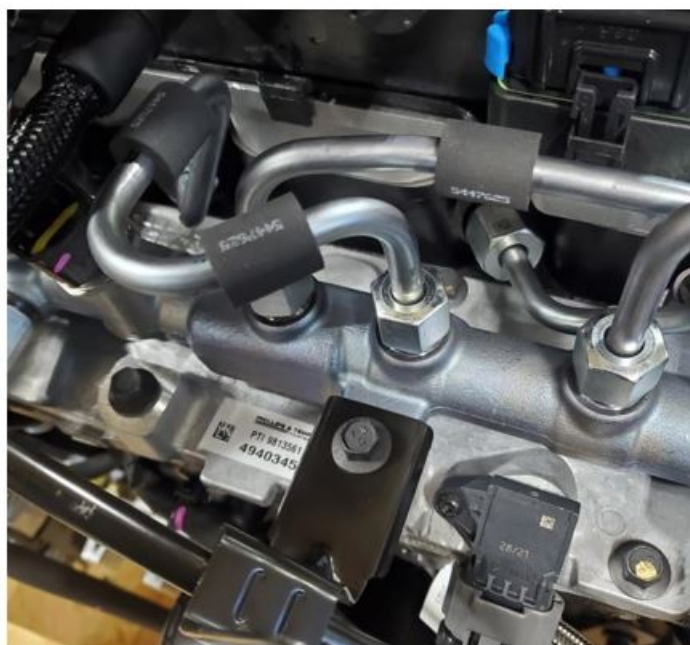

**Fig. 2**  
**Fuel Lines With Isolators\*\***

29. Install new high pressure fuel injection pump to rail supply lines.
30. Attach a suitable hose to the fuel return line fitting left disconnected at the tank in [Step 5](#).
31. Route the hose into a suitable container.

**CAUTION!** The PCM **MUST** be programmed with the correct calibration to support the new High Pressure Fuel Injection pump. If the correct PCM calibration with the CP3.3 injection pump description is not showing in wiTECH, “STOP” and contact Star.

**NOTE:** Install a battery charger to ensure battery voltage does not drop below 13.2 volts. Do not allow the charging voltage to climb above 13.5 volts during the flash process.

**NOTE:** If this flash process is interrupted/aborted, the flash should be restarted.

32. Reprogram the PCM with the correct calibration for the new High Pressure Fuel Injection Pump. Ensure that the calibration being selected is labeled with CP3.3 in the calibration description.
33. Clear all DTCs that may have been set in any module due to reprogramming. The wiTECH application will automatically present all DTCs after the flash and allow them to be cleared.
34. Using wiTECH, perform the “Oil Life Restore” procedure located in the ECM “Misc Functions”.
35. Prime the fuel system. Refer to Service Library, Service Information Section 14 – Fuel System > Fuel Delivery, Diesel > Standard Procedure > Fuel System Priming, Diesel.
36. Start the engine, and allow it to run until approximately 2-3 gallons of fuel has been captured from the fuel return line. This ensures that any debris in any of the remaining fuel return system components, including the cylinder head, has been fully expelled from the system.
37. Reconnect the chassis fuel return line at the tank.
38. Install the fuel tank. Refer to Service Library Service Information Section 14-Fuel System > Fuel Delivery, Diesel > Tank, Fuel > Installation.
39. Top off the fuel tank with fresh fuel if necessary, and verify the repair.

***HIGH PRESSURE FUEL INJECTION PUMP INSTALLATION:***

1. Remove the High Pressure Fuel Injection Pump. Refer to Service Library, Service Information Section 14-Fuel System > Fuel Delivery, Diesel > Pump, Fuel Injection > Removal.
2. Remove all three fuel pump mounting studs in the front gear housing and discard them (Fig. 3) .

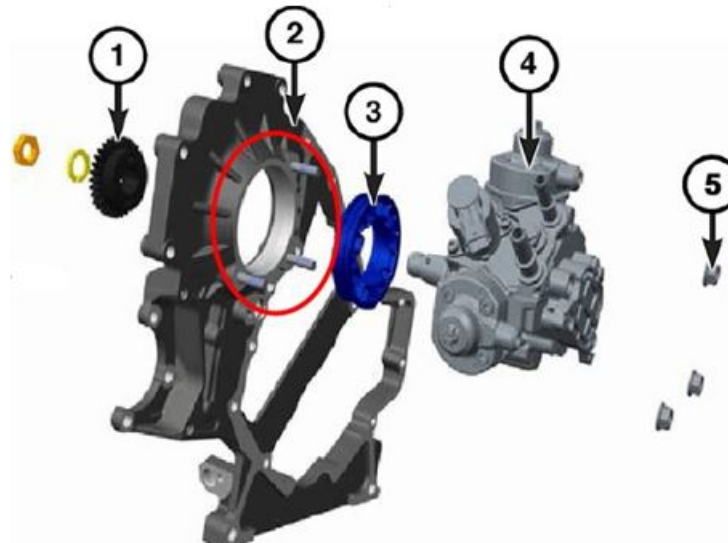

**Fig. 3**  
**Remove Stud Location**

- 1 - Fuel Pump Gear
- 2 - Pump Mounting Studs
- 3 - Pilot Adapter
- 4 - Fuel Pump
- 5 - Fuel Pump Mounting Nuts

3. Use a M8 x 1.25 tap to clean out all three holes where the studs were removed.
4. Install the fuel pump adapter plate (PN 68573989AA) with the flattened side pointing down so there is clearance for the cam positioning sensor and counterbores facing the fuel pump.
5. Install both of the bolts (PN 68578596AA) 25mm M8 in the 2 bolts holes near the engine (Fig. 4) .

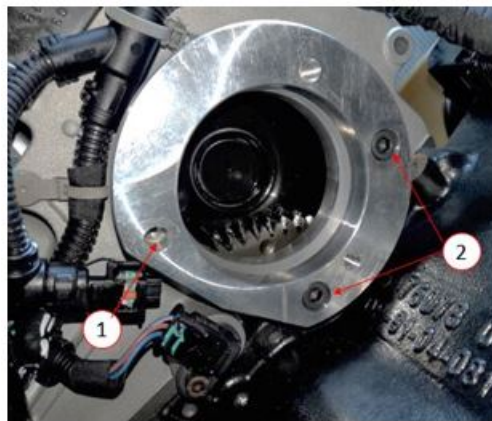

**Fig. 4**  
**Fuel Pump Mounting Adapter Plate**

- 1 - New Fuel Pump Faster location
- 2 - Adapter Plate Faster

6. Loosely install bolt (PN 4429446) in location (1) (Fig. 4) to help properly align the adapter before torquing bolts (PN 68578596AA). Torque both bolts (PN 3420835) to 24 N·m (17.7 ft.lbs.).
7. Remove the loosely installed bolt in location (1) (Fig. 4) . This will be used in a later step.

8. Before assembling the fuel pump, check and clean all mounting surface for nick, cuts or damage. Also check pump shaft and gear. Clean all surfaces of dirt and grease.

**NOTE: Do not use a hammer or press to install the pilot adapter on to the pump. The pilot adapter can be install by hand.**

9. Lubricate **new** O-ring (PN 68444371AA) on the pump body with engine oil and then install the pilot adapter onto the pump body with the smaller diameter side towards the fuel pump (Fig. 5) .

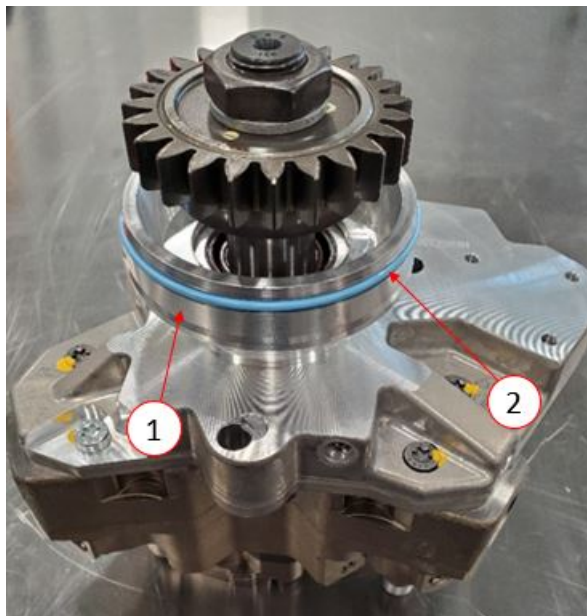
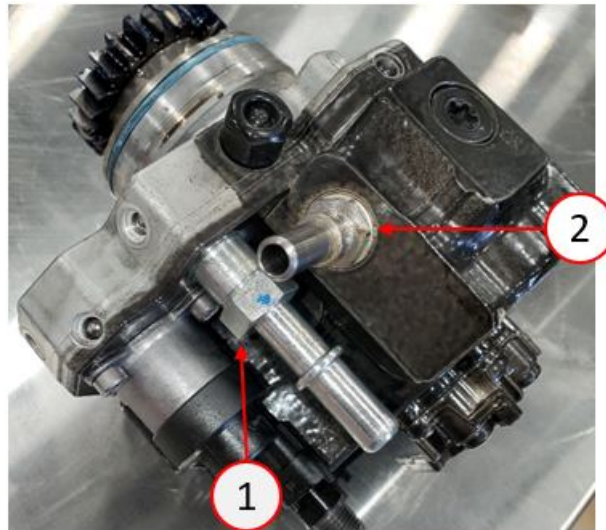

**Fig. 5**  
**Pilot Adapter on Fuel Pump**

- 1 - Pilot Adapter
  - 2 - Pilot Adapter O-ring
- 

10. Install the fuel pump gear onto the fuel pump shaft.
11. Using a **new** fuel pump washer (PN 68086175AA), install washer and original nut to pump shaft and tighten the nut finger tight only.
12. Use the Fuel Pump Gear Holder to hold the fuel pump gear in place while tightening the fuel pump gear mount nut to 105 N·m (77.4 ft.lbs.).

13. Install the supply and return quick disconnect fittings onto the pump as shown below and torque to 24 N·m (17.7 ft lbs) (Fig. 6) .



**Fig. 6**  
**Supply and Return Fitting Location**

- 1 - Return Quick Connect Fitting  
1 - Supply Quick Connect Fitting

14. **Fuel Injection Pump Phasing:** Perform the following phasing procedure anytime the injection pump has been removed and reinstalled.
15. Make sure engine cylinder 1 is at Top Dead Center (TDC) position.
16. Locate the end of the fuel injection pump shaft . Two numbers (750 or 754 and 0) are stamped into the end of the shaft.
17. Rotate the injection pump shaft until the number 5 (located in the center of number 750 or 754) is positioned at 9 o'clock (Fig. 7) .

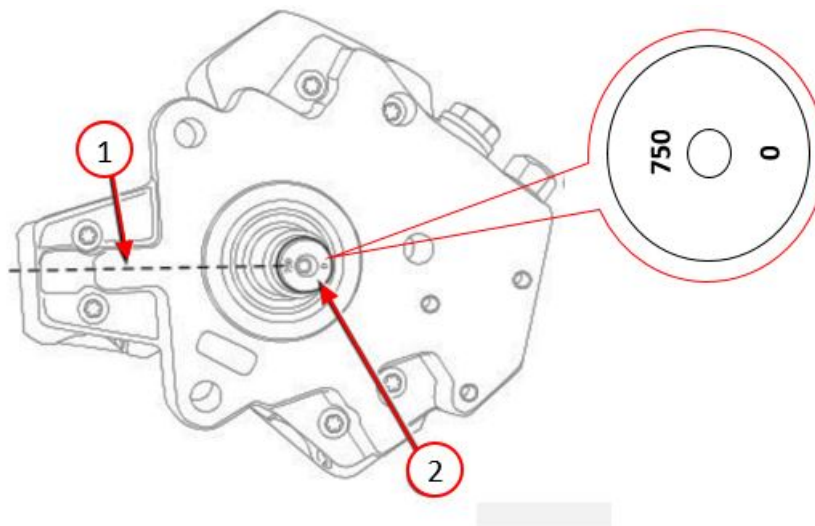

**Fig. 7**  
**Fuel Pump Shaft**

- 1 - 9 O-Clock Position  
2 - Shaft With 750/754 Markings

18. Position the injection pump to mounting flange on gear housing while aligning injection pump shaft through back of injection pump gear. Be sure the number 5 is still at the 9 o'clock position.
19. Before installing the pump use a clean rag, wipe the back side of the camshaft gear to remove residual oil. It is only necessary to wipe the portion of the camshaft gear which is accessible through the fuel pump bore in the gear housing.
20. The pump will need to be rotated to fit correctly in the space claim.
21. Install the long 60 mm cap screw (PN 4429446). (Fig. 8) first loosely (yellow bolt in picture below).
22. Then install the two shorter 40 mm cap screws (PN 4638665) (Fig. 8) (blue bolt in picture below).

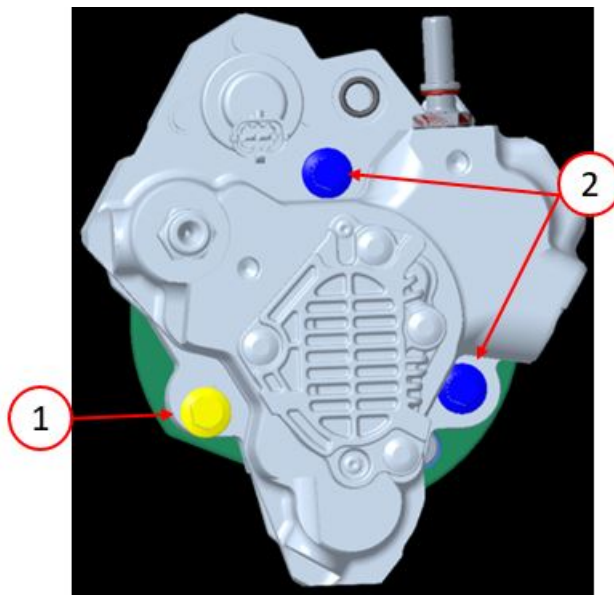

**Fig. 8**  
**Fuel Pump Faster Location**

- 1 - 60 mm cap screw (PN 4429446)
- 2 - 40 mm cap screws (PN 4638665)

23. Ensure that the fuel pump is sitting flush to the adapter face.
24. Ensure that there is adequate clearance to the cam position sensor and the paint cap is removed if needed.
25. Torque the fuel pump cap screws to 24Nm (17.7 ft.lbs.).

26. Install the fuel pump tail support bracket to fuel pump. Loosely install the tail support bracket on the fuel pump using bolt (PN 4429114) 30mm M8 (Fig. 9) .

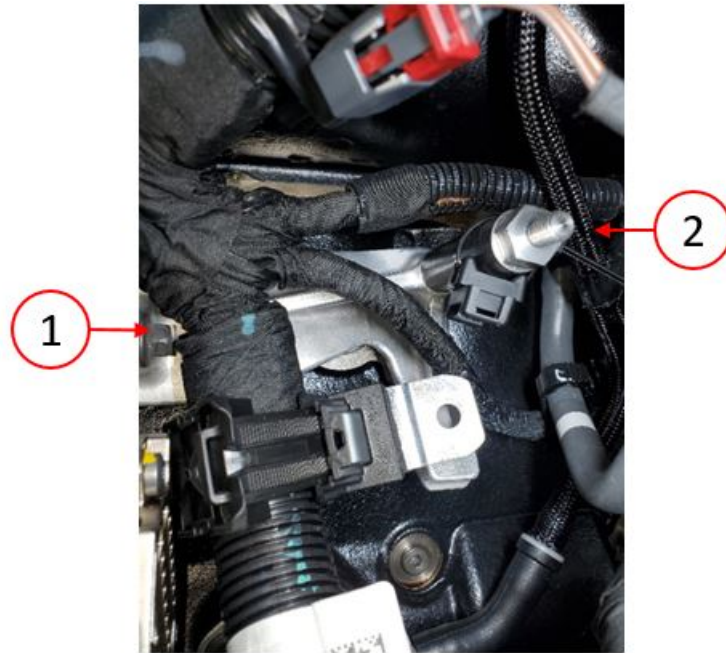

Fig. 9

#### Fuel Pump Tail Support Bracket Location

- 1 - Tail Support Bracket Mounting Bolt  
2 - Fuel Line Stand off Tail Support

27. Loosely install the fuel line standoff to block through the tail support (68573994AA).  
28. Torque both ends of the fuel pump tail support to 24 N·m (17.7 ft.lbs.).  
29. The tie down bracket **must** be loosened so it can be rotated and positioned to be secured to the leg of the fuel pump tail support to ensure there is no twisting of the main engine harness. The tie down bracket can be loosened by inserting a small flat head screwdriver into a slot in the tie down (Fig. 10) .

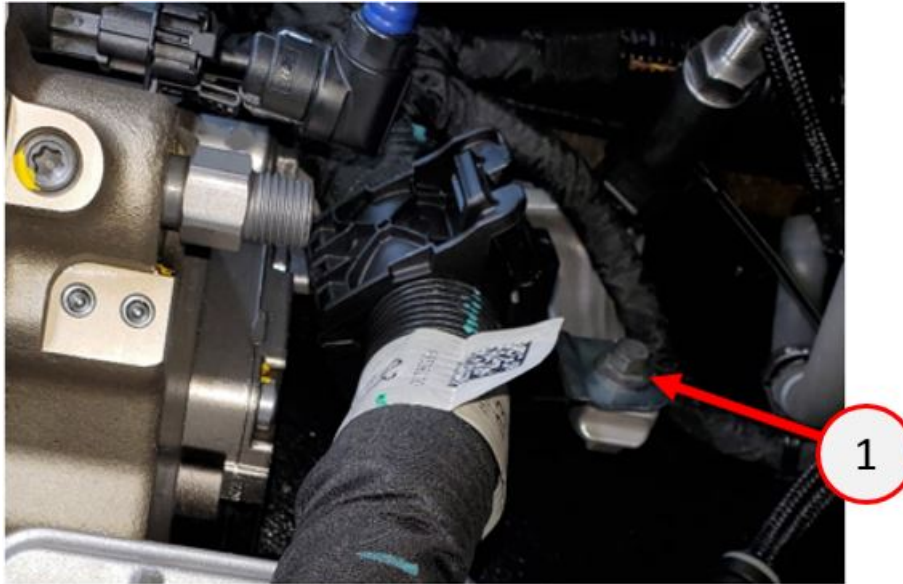

Fig. 10

#### Main Harness Tie down Bracket

- 1 - Slot Location to Loosen Tie Down

30. With the tie down bracket still loose around the main engine harness, secure the tie down bracket to the tail of the fuel pump tail support using bolt (PN 4429630) and torque bolt to 10 N·m (7.3 ft.lbs.). Tighten the tie down bracket around the main engine harness using the zip closure (Fig. 11) .

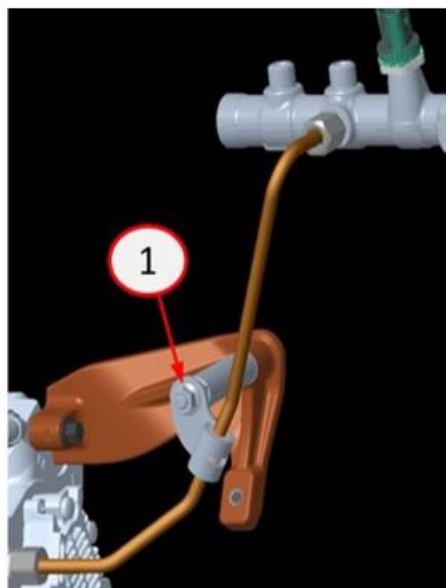

**Fig. 11**  
**Main Engine Harness Tie down Bracket**

1 - Harness Bracket and FASTER

---

31. Finger tighten both fuel tube union nuts at the pump and the fuel rail. Make sure the bracket slot aligns to the standoff, slide bracket along the tube to align if slightly off.
32. Finger tighten on the M8 nut (PN 4429689).
33. Tighten the union nut at the pump first then the fuel rail to proper torque 55 N·m (40.5 ft.lbs.)(Fig. 12) .



**Fig. 12**  
**Fuel Rail FASTER**

1 - Union Nut

---

34. Torque the High-Pressure Pump to Fuel Rail Supply line bracket bolt (PN 68573994AA) M8 115mm to proper torque 20 N·m (14.7 ft.lbs.).
35. Ensure there is no interference with the breather hose, pull the breather hose away from the High-Pressure line if there is contact.

**NOTE: There will only be 1 High-Pressure Pump to Fuel Rail Supply line.**

**NOTE: The rail block nut is a one time use part. If this nut is ever loosened or removed, it must be replaced with a new block of nut.**

36. The second supply port in the rail will need to be blocked off using rail block off nut (PN 68573999AA) and torque to 55 N·m (40.5 ft.lbs.).
37. Install the new ECM mounting bracket using the same top bolts that came out of the original mounting bracket install them in the new mounting bracket and torque to 24 N·m (17.7 ft.lbs.).
38. Using the provided bottom bolts (PN 68578595AA) install them into the new mounting bracket and torque to 24 N·m (17.7 ft.lbs.) (Fig. 13) .

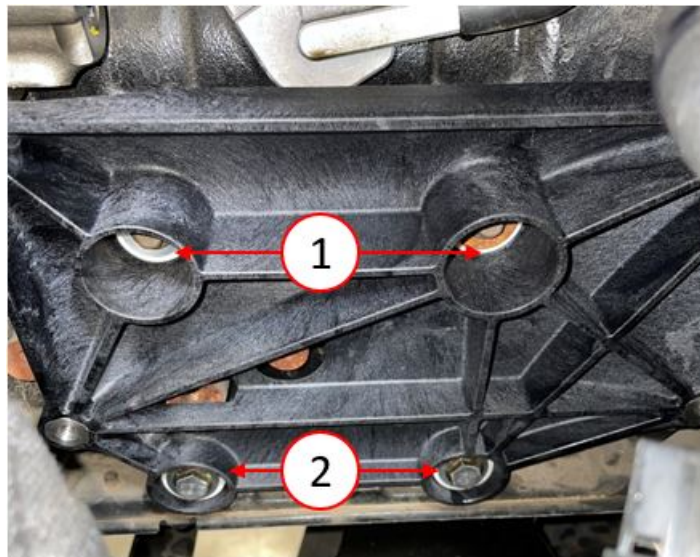
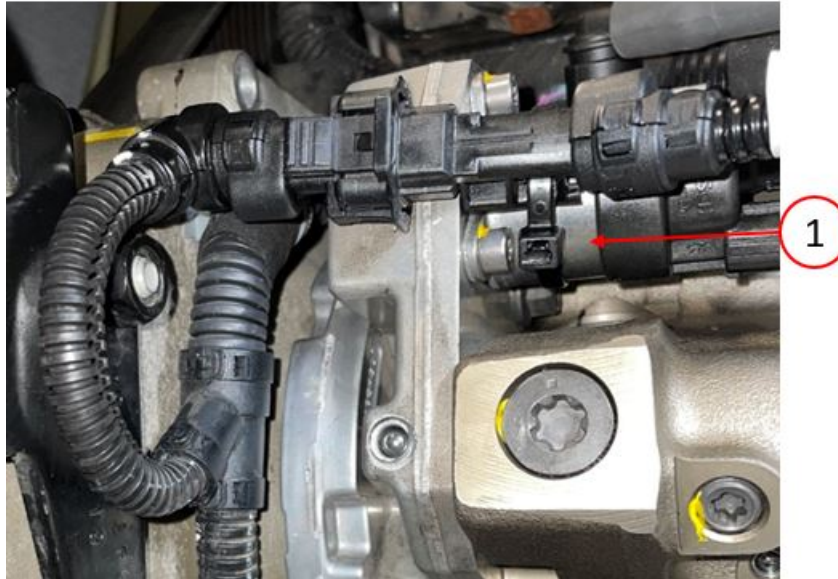

**Fig. 13**  
**New ECM Mounting Bracket and Faster Location**

- 1 - Original Bracket Bolts
- 2 - New Bolts (PN 5689141)

39. Replace the power steering pressure hose (PN 68359768AF) from pump to hydroboost with the line provide in the kit.
40. Install the ECM to the new mounting bracket with the same hardware from when it was originally removed.
41. Install the ECM and torque all bolts to 24 N·m (17.7 ft.lbs.).
42. Connect the engine and transmission wire harness connector to the PCM and rotate the latches closed.
43. Install the fasteners securing the engine wire harness and the transmission wiring harness to the ECM and torque them to 10 N·m (7.3 ft.lbs.).
44. Connect the low-pressure return line (PN 68573996AA) to the fuel filter support bracket .
45. Connect the low-pressure supply line (PN 68573996AA) to the fuel filter housing.
46. Connect the low-pressure supply and return lines to the fuel pump.
47. Reattach the standoff clip between the drain line and the harness.

- 48. Install and connect Engine Wiring Harness Jumper (PN 68573991AA) to Fuel Quantity Solenoid. Connect the female side of the jumper harness to the engine wiring harness that originally attached to the Fuel Quantity Solenoid (Fig. 14) .

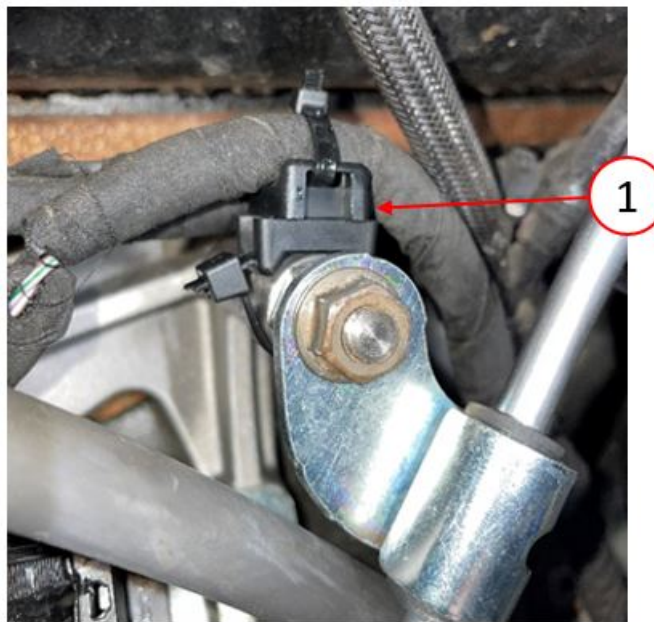

**Fig. 14**  
**Location of Tie down on Quantity Solenoid**

1 - Tie Down

---

- 49. Connect the male side of the jumper to the Fuel Quantity Solenoid on the fuel pump.
- 50. Tie down the jumper using the provided zip-tie (PN 68038172AA) (1) as shown in the picture below.
- 51. Using the provided zip-ties (PN 68038172AA) attach the swivel bracket to the fuel line standoff and secure the wire harness pig tail to the swivel bracket (Fig. 15) .



**Fig. 15**  
**Tie Down Location Swivel Bracket Tie Down Location**

1 - Tie Down

---

52. Connect the negative battery cable(s).

53. Complete the fuel system repair. Go back to [Step 26](#) of the Repair Procedure.

**POLICY:**

Reimbursable within the provisions of the warranty.

**TIME ALLOWANCE:**

**NOTE:** The in-tank lift pump replacement is already part of the kit installation LOP.

**NOTE:** Dealers that are charged for a Fuel Disposal fee must enter the reimbursement request as a sublet repair in the Special Service section of the claim. The request for reimbursement must be supported with a copy of the Fuel Disposal Fee invoice when the claim is submitted for review.

Labor Operation No:	Description	Skill Category	Amount
14-45-01-97	Kit - Fuel System Install and Flush Fuel System (2 - Skilled)	10 - Diesel	10.3 Hrs.

**OPTIONAL EQUIPMENT:**

Labor Operation No:	Description	Skill Category	Amount
14-45-01-62	Dual Alternator Equipped (2 - Skilled)	10 - Diesel	0.5 Hrs.
14-45-01-63	Adaptive Steering System Equipped (Sales Code SJE) (2 - Skilled)	10 - Diesel	0.6 Hrs.

**FAILURE CODE:**

ZZ	Service Action
----	----------------



**NUMBER:** 18-060-20 REV. A

**GROUP:** 18 - Vehicle Performance

**DATE:** October 21, 2020

*This bulletin is supplied as technical information only and is not an authorization for repair. No part of this publication may be reproduced, stored in a retrieval system, or transmitted, in any form or by any means, electronic, mechanical, photocopying, or otherwise, without written permission of FCA US LLC.*

**This bulletin supersedes Service Bulletin , dated August 07, 2020, which should be removed from your files. All revisions are highlighted with **\*\*asterisks\*\*****

**This bulletin supersedes Technical Service Bulletin (TSB) 18-060-20, date of issue August 07, 2020, which should be removed from your files. All revisions are highlighted with **\*\*asterisks\*\*** and include additional market and note for generic software release awareness.**

**SUBJECT:**

6.7L Cummins Engine High Pressure Fuel Injection Pump Identification Differences

**OVERVIEW:**

This bulletin provides information regarding the identification differences in the high pressure fuel injection pumps between the new style Symetrical Cam design pump and the old syle Asymetrical Cam design used on the 6.7L Cummins in the 2019 and 2020 HD Trucks. The following information is intended to eliminate confusion and possible noise complaints shortly after pump replacement or ECM reprogramming.

**MODELS:**

2019 - 2020	(DJ)	RAM 2500 Pickup
2019 - 2020	(D2)	RAM 3500 Pickup
2019 - 2020	(DD)	RAM 3500 Cab Chassis
2019 - 2020	(DP)	RAM 4500/5500 Cab Chassis

**NOTE:** This bulletin applies to vehicles within the following markets/countries: North America and **\*\*LATAM\*\***.

**NOTE:** This bulletin applies to vehicles equipped with a 6.7L I6 Cummins Turbo Diesel Engine (Sales Code ETL or ETN) or 6.7L I6 Cummins HO Turbo Diesel Engine (Sales Code ETM).

**NOTE:** **\*\*Generic software support is available for the new design Symmetrical Cam Injection Pumps for LATAM market\*\***

**DISCUSSION:**

**NOTE:** Two calibration choices may be present when flashing the ECM. Please follow the published technical service bulletin closely to avoid choosing the incorrect calibration. Choosing the incorrect calibration will result in an undesirable noise from the High Pressure Fuel Pump, requiring the ECM to be flashed again with the correct calibration.

Whenever an ECM is replaced, or reprogrammed for any reason, the fuel injection pump must be inspected to determine which design pump is installed on the vehicle. Additionally, when a fuel injection pump is replaced with a new design pump, the ECM must be programmed with the correct calibration to support this new design pump.

Older design pumps have a Asymmetrical design internal cam. The newer design pumps have a Symmetrical design internal cam. The design of the pump will determine which calibration will need to be programmed into the ECM. From outward appearance both pumps look identical, with the exception of specific identification marks machined into the body of the pump.

The inspection procedures listed below outline how to identify which design injection pump is installed so that a technician can verify that the ECM is programmed with the correct calibration.

1. Inspect the fuel injection pump to see which pump the vehicle has:

- Vehicles with the new style Symmetrical Cam design pump will have one large single dot embossed in the pump housing (Fig. 1) .
- Vehicles equipped with a Symmetrical Cam pump, choose the calibration labeled Symetric Cam, or Sym Cam.



**Fig. 1**  
**New Style Symmetrical Cam Design Pump**

1 - One large Single Dot on Housing

- Vehicles with the old syle Asymmetrical Cam design will have either multiple dots or no dots embossed in the pump housing (Fig. 2) .
- Vehicles with an Asymmetrical Cam pump, choose the calibration labeled Asymetric Cam or Asym Cam.

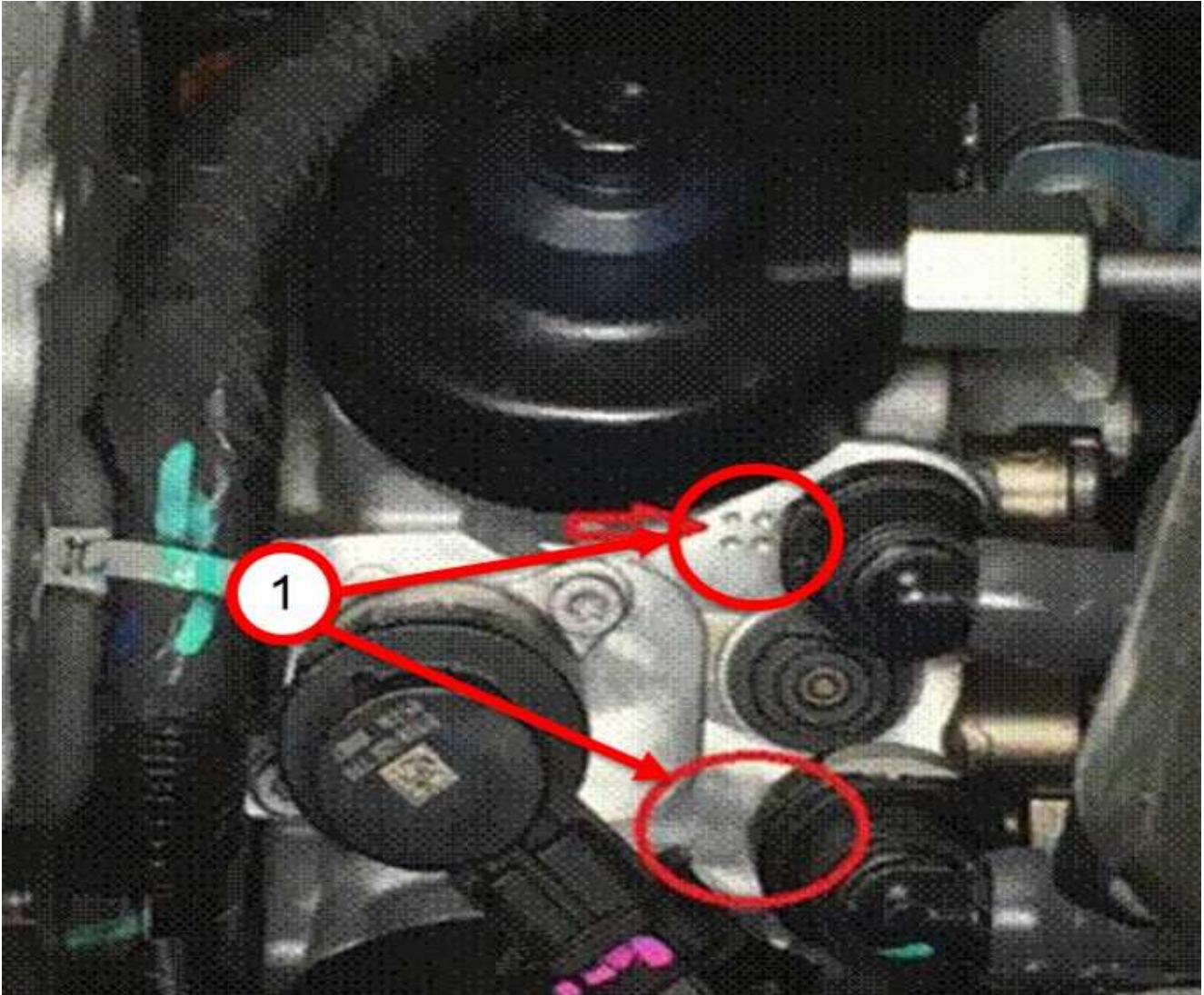

Fig. 2

Old Style Asymmetrical Cam Design Pump

1 - Multiple Dots on Housing

---

**POLICY:**  
Information Only



# WARRANTY BULLETIN

**TO:** Dealer Principal, Service Manager, Service Advisor, Parts Manager and Warranty Claims Administrator

**NO:** D-19-02

**DATE:** **November 25, 2020**

**SUBJECT:** Fast Feedback Program – 6.7L Cummins Engine - 2019 & 2020 HD Ram & **Fuel Injection Pump** – All Models (Rev. F)

**FOR:** All U. S. Dealers  
All U. S. Business Centers

\*\*\*\*\*Revisions are noted in RED\*\*\*\*\*

## PURPOSE

To announce that this Fast Feedback Program for replacing the **6.7L Cummins Engine (Sales Codes ETL, ETM or ETN)** and **Fuel Injection Pump** for the **2019 and 2020 HD Ram** has been **extended** in an effort to collect, monitor and correct quality issues in a timely and efficient manner.

## Models affected:

- 2019 and 2020 HD Ram (D2/DD/DF/DJ/DP)

## TIMING:

November 1, 2019 – **May 31, 2021**

**NOTE:** At the end of this Fast Feedback program, normal Parts Ordering and Service Information procedures will apply.

## ACTION:

When customer input and technician diagnosis suggests an engine, **fuel injection pump**, drivability or electronic issue, the dealer must:

- Review the nature of the problem and perform all necessary diagnostics.
- Contact the STAR Center at **1-800-850-7827** or by creating a STAR case and providing the details of the problem and the diagnostics.

**NOTE:** All parts needed for these repairs will be “order restricted” during the term of this program. If these need replacement, please contact the STAR Center for critical warranty information.





- If an engine or **fuel injection pump** repair is necessary, you will be advised by STAR of any special instructions regarding component removal and return.
- To avoid damage and fluid spills, all returned parts must be shipped in the same container provided with the new replacement part.

**NOTE: DO NOT disassemble the engine without prior approval from STAR. Chargebacks will be imposed for unauthorized internal engine diagnostics.**

All replaced engine assemblies must be returned using UPS (Heavy) transportation. A STAR Center representative will initiate the Fast Track process to ensure proper component packaging and return.

**DO NOT** return engines via DDS.

### **FUEL INJECTION PUMP - STAR Case Tips for First Contact Resolution**

The following information must be provided to STAR in order for STAR to process the order for a restricted fuel system component:

1. **Vehicle Scan Report**
2. **wiTECH Duty Cycle Report** (email to FCA\_DC@cummins.com)
  - 1.) Connect to the truck using WiTech 2.0 MicroPod  
**NOTE:** If there is a flash available for the PCM, do not flash the PCM as you will lose the duty cycle information.
  - 2.) From the topology screen, select the PCM module
  - 3.) Select the Misc. Functions tab
  - 4.) Select Cummins 6.7L Duty Cycle Monitor
  - 5.) Run the routine, it takes about 10 seconds
  - 6.) You will then be prompted to input an email address. Input FCA\_DC@cummins.com as the email address and be sure to click "**Add**" after doing so otherwise the email will not be sent.  
- After selecting add click continue.
3. **Inspect the fuel system for external contamination and describe in STAR Case Narrative**
4. **Take a clear photo of the FQS and FQS Bore of the pump to confirm the failure (see example below)**





### **ADDITIONAL INFORMATION:**

**NOTE:** It is possible for a vehicle to have multiple parts on restriction.

Alternate transportation reimbursement requests can be submitted on the same claim as the warranty repair. Refer to Warranty Bulletin D-19-28 (Rev. B) for complete Goodwill Alternate Transportation Guidelines.

**Please ensure that all affected dealership personnel are aware of this bulletin.**

## **WARRANTY OPERATIONS**

FCA US LLC reserves the right to change any or all of the rules set forth in the Dealer Policy Manual and the Warranty Administration Manual by means of Warranty Bulletins and also by making the amended manual available to you on DealerCONNECT.





## **New Safety Recall Advanced Communication – Y78**

FCA US LLC (FCA US) has announced a safety recall on certain 2019 through 2020 Model Year (D2) Ram 3500 Pickup, (DD) Ram 3500 Cab Chassis, (DJ) Ram 2500 Pickup and (DP) Ram 4500/5500 Cab Chassis vehicles equipped with a 6.7L diesel engine.

VINs identified as being involved in this campaign are currently live and searchable.  
**Stop sale is in effect for the above-identified vehicles.**

Vehicles impacted by a stop sale are eligible for reimbursement allowance through the Recall Floorplan Reimbursement Policy (RFPRP), which can be requested upon recall claim submission.

**IMPORTANT:** Some of the involved vehicles may be in dealer new vehicle inventory. Federal law requires you to complete this recall service on these vehicles before retail delivery. Violation of this requirement by a dealer could result in a civil penalty of up to \$21,000 per vehicle. Involved vehicles can be determined by using the VIP inquiry process.

### **REASON FOR THIS SAFETY RECALL**

Some of the above vehicles may have been built with a High Pressure Fuel Pump (HPFP) that could fail prematurely. A high pressure fuel pump failure may introduce internally failed component debris into the fuel system potentially causing fuel starvation. Vehicle occupants may notice a Malfunction Indicator Lamp illuminating, a fuel leak, abnormal engine noise, or a change in drive quality. Fuel starvation may result in an unexpected loss of motive power, which can cause vehicle crash without prior warning.

### **SERVICE ACTION**

FCA US will conduct a voluntary safety recall to replace the HPFP, update the Powertrain Control Module (PCM) software, and inspect and, if necessary, replace additional fuel system components. The remedy for this condition is not currently available. Dealers will be notified of the launch of this safety recall by way of established communication methods. This recall is estimated to launch in 1st Quarter of 2022.

We ask that you please take the time to ensure that your personnel are aware of this communication and are prepared to execute a customer friendly process for inquiries regarding involved vehicles.

Customer Services Field Operations  
FCA US LLC



Revised 12/11/2021

**NOTE: Additional parts have been included to this notification.**

## **New Safety Recall Advanced Communication – Y87**

FCA US LLC has announced an equipment safety recall on certain:

Mopar High Pressure Fuel Pump 68444767AA  
Mopar High Pressure Fuel Pump 68503520AA  
Mopar High Pressure Fuel Pump 68503523AA  
Mopar High Pressure Fuel Pump 68526413AA  
Mopar High Pressure Fuel Pump 68526414AA  
Mopar 6.7L Cummins Turbo Diesel Engine R3041229AA  
Mopar 6.7L Cummins Turbo Diesel Engine R3041230AA  
Mopar 6.7L Cummins Turbo Diesel Engine R3041231AA  
Mopar 6.7L Cummins Turbo Diesel Engine R3041233AA  
Mopar 6.7L Cummins Turbo Diesel Engine R3041233AB

**Mopar High Pressure Fuel Pump 68563967AA**

**Mopar High Pressure Fuel Pump Kit (Standard Output Engine) R8545067AA**

**Mopar High Pressure Fuel Pump Kit (High Output Engine) R8545068AA**

### **REASON FOR THIS SAFETY RECALL**

Some high pressure fuel pumps (HPFPs) were improperly designed and could fail prematurely. A high pressure fuel pump failure may introduce internally failed component debris into the fuel system potentially causing fuel starvation if installed into a vehicle. Vehicle occupants may notice a Malfunction Indicator Lamp illuminating, a fuel leak, abnormal engine noise, or a change in drive quality. Fuel starvation may result in an unexpected loss of motive power, which can cause a vehicle crash without prior warning.

### **SERVICE ACTION**

FCA US will conduct a voluntary safety recall on all affected parts to repurchase suspect HPFPs and engines. The remedy for this condition is not currently available. Dealers will be notified of the launch of this safety recall by way of established communication methods. This recall is estimated to launch in 1st Quarter of 2022.

We ask that you please take the time to ensure that your personnel are aware of this communication and are prepared to execute a customer friendly process for inquiries regarding involved vehicles.

Customer Services Field Operations  
FCA US LLC



## STAR ONLINE PUBLICATION



**Case Number: S201400002 REV. C**

**Release Date: December 2021**

**Symptom/Vehicle Issue:** Metal Or Other Debris Contamination In The High Pressure Fuel System. Star Parts Restriction Process.

**Discussion:** The part numbers and repair procedure released under TSB 18-054-21 have now been updated. To ensure the correct parts are being ordered, and the proper repair being performed, the new fuel system kits will remain on Star Restriction for the time being.

**NOTE:** The new fuel injection pump kit is a VIN specific part. The part being ordered **MUST** be installed on the VIN it is being ordered for. Ordering by VIN enables the correct software to be programmed into the PCM to support the new injection pump.

**NOTE:** Per the revised TSB, the PCM **MUST** be programmed with the correct software at the completion of the repair. Please be sure to closely follow the repair instructions outlined in TSB 18-054-21 REV. A.

The following information must be provided to STAR in order for STAR to process the order for a restricted fuel system component:

To process the Function 11 VIN order for the injection pump, please provide the following information in the Star case.

- a. First 4 letters of the customer's last name or business name.
- b. First initial of the customer's first name if applicable.
- c. Repair order number.

This document does not authorize warranty repairs. This communication documents a record of past experiences. STAR Online does not provide any conclusions about what is wrong with the vehicle. Rather, it captures all previous cases known that appear to be similar or related to the vehicle symptom / condition. You are the expert, and you are responsible for deciding on the appropriate course of action.

**Contact STAR Center, or your Technical Assistance Center Via TechCONNECT or eCONTACT ticket if no solution is found**



## STAR ONLINE PUBLICATION



- d. Engine ESN number. The ESN number is located on the sticker on the valve cover. See (Figure 1.)



**Figure 1.**

Additionally, please provide the following information to Star.

1. Vehicle Scan Report
2. wiTECH Duty Cycle Report (email to [FCA\\_DC@cummins.com](mailto:FCA_DC@cummins.com)). To obtain the report, refer to the following steps:

**NOTE: If there is a flash available for the PCM do not flash the PCM as you will lose the duty cycle information.**

- a. Connect to the vehicle using WiTech 2.0 MicroPod
- b. From the topology screen, select the PCM module.
- c. Select the Misc. Functions tab
- d. Select Cummins 6.7L Duty Cycle Monitor. The routine will take about 10 seconds.

This document does not authorize warranty repairs. This communication documents a record of past experiences. STAR Online does not provide any conclusions about what is wrong with the vehicle. Rather, it captures all previous cases known that appear to be similar or related to the vehicle symptom / condition. You are the expert, and you are responsible for deciding on the appropriate course of action.

**Contact STAR Center, or your Technical Assistance Center Via TechCONNECT or eCONTACT ticket if no solution is found**



## STAR ONLINE PUBLICATION



- e. You will then be prompted to input an email address. Input FCA\_DC@cummins.com as the email address and be sure to click "Add" after doing so otherwise the email will not be sent. After selecting add click continue.
3. Inspect the fuel system for external contamination and describe if any found in the STAR Case narrative.
4. Collect a fuel sample in a clean container, and take a clear picture of it. Attach the picture to the Star case.
5. Take a clear photo of the FQS and FQS Bore of the pump to confirm the failure, and attach it to the case. See (Figure 2.) for a good example



**Figure 2.**

This document does not authorize warranty repairs. This communication documents a record of past experiences. STAR Online does not provide any conclusions about what is wrong with the vehicle. Rather, it captures all previous cases known that appear to be similar or related to the vehicle symptom / condition. You are the expert, and you are responsible for deciding on the appropriate course of action.

**Contact STAR Center, or your Technical Assistance Center Via TechCONNECT or eCONTACT ticket if no solution is found**

A document titled  
***Y78 Dealer DRAFT\_CONF BUS INFO.pdf*** was SUBMITTED TO THE NHTSA  
OFFICE OF CHIEF COUNSEL WITH A REQUEST FOR CONFIDENTIAL  
TREATMENT

This notice applies to your vehicle,

[Model Year and Model]

VIN XXXXXXXXXXXXXXXXXXXX

Y78/NHTSA 21V-880

LOGO

VEHICLE PICTURE

### YOUR SCHEDULING OPTIONS

1. Visit [recalls.mopar.com](https://recalls.mopar.com) to sign up for email or SMS notifications for when remedy parts become available. You will be asked to provide your Vehicle Identification Number (VIN), provided above
2. Scan below using your smartphone or tablet to sign up to be notified when remedy parts become available
3. Wait for FCA US to contact you again, by mail, with a follow-up recall notice when remedy parts are available
4. Call the FCA Recall Assistance Center at 1-800-853-1403. An agent can sign you up to be notified when remedy parts become available, or answer any other questions you may have

QR Code

### DEALERSHIP INSTRUCTIONS

Please reference Safety Recall Y78.

# IMPORTANT SAFETY RECALL

## High Pressure Fuel Pump

Dear [Name],

This notice is sent to you in accordance with the National Traffic and Motor Vehicle Safety Act.

FCA US has decided that a defect, which relates to motor vehicle safety, exists in certain [2019 through 2020 Model Year (D2) Ram 3500 Pickup, (DD) Ram 3500 Cab Chassis, (DJ) Ram 2500 Pickup and (DP) Ram 4500/5500 Cab Chassis] vehicles.

### WHY DOES MY VEHICLE NEED REPAIRS?

The high pressure fuel pump (HPFP) on your vehicle <sup>[1]</sup> may fail prematurely. A high pressure fuel pump failure may introduce internally failed component debris into the fuel system potentially causing fuel starvation. Vehicle occupants may notice a Malfunction Indicator Lamp illuminating, a fuel leak, abnormal engine noise, or a change in drive quality. **Fuel starvation may result in an unexpected loss of motive power, which can increase the risk of a vehicle crash without prior warning.**

### HOW DO I RESOLVE THIS IMPORTANT SAFETY ISSUE?

**The remedy for this condition is not currently available.** We are making every effort to finalize the remedy as quickly as possible, and will service your vehicle free of charge (parts and labor) when the remedy is available.

FCA US will contact you again, by mail, with a follow-up recall notice when the remedy is available. Once you receive your follow-up notice, simply contact your Chrysler, Jeep®, Dodge or RAM dealer right away to schedule a service appointment <sup>[2]</sup>. Additional options for your next steps are included on the left side of this notification. We appreciate your patience.

### WHAT IF I ALREADY PAID TO HAVE THIS REPAIR COMPLETED?

If you have already experienced this specific condition and have paid to have it repaired, you may visit [www.fcarecallreimbursement.com](https://www.fcarecallreimbursement.com) to submit your reimbursement request online <sup>[3]</sup>. Once we receive and verify the required documents, reimbursement will be sent to you within 60 days. If you have had previous repairs performed and/or already received reimbursement, you may still need to have the recall repair performed.

We apologize for any inconvenience, but are sincerely concerned about your safety. Thank you for your attention to this important matter.

Customer Assistance/Field Operations  
FCA US LLC



**Mr. Mrs. Customer**  
**1234 Main Street**  
**Hometown, MI 48371**

[1] If you no longer own this vehicle, please help us update our records. Call the FCA Recall Assistance Center at 1-800-853-1403 to update your information.

[2] If your dealer fails or is unable to remedy this defect without charge and within a reasonable time, you may submit a written complaint to the Administrator, National Highway Traffic Safety Administration, 1200 New Jersey Ave., S.E., Washington, DC 20590, or you can call the toll-free Vehicle Safety Hotline at 1-888-327-4236 (TTY 1-800-424-9153), or go to [safercar.gov](http://safercar.gov).

[3] You can also mail in your original receipts and proof of payment to the following address for reimbursement consideration: FCA Customer Assistance, P.O. Box 21-8004, Auburn Hills, MI 48321-8007, Attention: Recall Reimbursement.

Note to lessors receiving this recall notice: Federal regulation requires that you forward this recall notice to the lessee within 10 days.

# IMPORTANT SAFETY RECALL

## High Pressure Fuel Pump

Y87/NHTSA 21E-094

Dear [Name],

This notice is sent to you in accordance with the National Traffic and Motor Vehicle Safety Act.

FCA has decided that a defect, which relates to motor vehicle safety, exists in certain MOPAR high pressure fuel pumps: Mopar High Pressure Fuel Pump 68444767AA, Mopar High Pressure Fuel Pump 68503520AA, Mopar High Pressure Fuel Pump 68503523AA, Mopar High Pressure Fuel Pump 68526413AA, Mopar High Pressure Fuel Pump 68526414AA, Mopar 6.7L Cummins Turbo Diesel Engine R3041229AA, Mopar 6.7L Cummins Turbo Diesel Engine R3041230AA, Mopar 6.7L Cummins Turbo Diesel Engine R3041231AA, Mopar 6.7L Cummins Turbo Diesel Engine R3041233AA, Mopar 6.7L Cummins Turbo Diesel Engine R3041233AB, Mopar High Pressure Fuel Pump 68563967AA, Mopar High Pressure Fuel Pump Kit (Standard Output Engine) R8545067AA, Mopar High Pressure Fuel Pump Kit (High Output Engine) R8545068AA.

It is extremely important to take steps now to repair your vehicle to ensure the safety of you and your passengers.

### WHY DOES MY VEHICLE NEED REPAIRS?

FCA records indicate that you may have purchased a MOPAR high pressure fuel pump (HPFP) or engine assembly with an installed HPFP for your vehicle <sup>[1]</sup>. Some HPFPs were improperly designed and could fail prematurely. A high pressure fuel pump failure may introduce internally failed component debris into the fuel system potentially causing fuel starvation if installed into a vehicle. Vehicle occupants may notice a Malfunction Indicator Lamp illuminating, a fuel leak, abnormal engine noise, or a change in drive quality. **Fuel starvation may result in an unexpected loss of motive power, which can increase the risk of a vehicle crash without prior warning.**

### HOW DO I RESOLVE THIS IMPORTANT SAFETY ISSUE?

**The remedy for this condition is not currently available.** We are making every effort to finalize the remedy as quickly as possible, and will service your vehicle free of charge (parts and labor) when the remedy is available.

FCA US will contact you again, by mail, with a follow-up recall notice when the remedy is available. Once you receive your follow-up notice, simply contact your Chrysler, Jeep®, Dodge or RAM dealer right away to schedule a service appointment <sup>[2]</sup>. Additional options for your next steps are included on the left side of this notification. We appreciate your patience.

### WHAT IF I ALREADY PAID TO HAVE THIS REPAIR COMPLETED?

If you have already experienced this specific condition and have paid to have it repaired, you may visit [www.fcarecallreimbursement.com](http://www.fcarecallreimbursement.com) to submit your reimbursement request online. <sup>[3]</sup> Once we receive and verify the required documents, reimbursement will be sent to you within 60 days. If you have had previous repairs performed and/or already received reimbursement, you may still need to have the recall repair performed.

We apologize for any inconvenience, but are sincerely concerned about your safety. Thank you for your attention to this important matter.

Customer Assistance/Field Operations  
FCA US LLC

## YOUR SCHEDULING OPTIONS

- 1. RECOMMENDED OPTION**  
Call your authorized Chrysler / Dodge / Jeep® / RAM Dealership
- 2. Call the FCA Recall Assistance Center at 1-800-853-1403. An agent can confirm part availability and help schedule an appointment**
- 3. Visit recalls.mopar.com or download the Mopar Owner's Companion App.**

Get access to recall notifications, locate your nearest dealer, and more through this website or Mopar Owner's Companion App. You will be asked to provide your Vehicle Identification Number (VIN) to protect and verify your identity.

## DEALERSHIP INSTRUCTIONS

Please reference Safety Recall Y87.



**Mr. Mrs. Customer**  
**1234 Main Street**  
**Hometown, MI 48371**

[1] If you no longer own this vehicle, please help us update our records. Call the FCA Recall Assistance Center at 1-800-853-1403 to update your information.

[2] If your dealer fails or is unable to remedy this defect without charge and within a reasonable time, you may submit a written complaint to the Administrator, National Highway Traffic Safety Administration, 1200 New Jersey Ave., S.E., Washington, DC 20590, or you can call the toll-free Vehicle Safety Hotline at 1-888-327-4236 (TTY 1-800-424-9153), or go to [safercar.gov](http://safercar.gov).

[3] You can also mail in your original receipts and proof of payment to the following address for reimbursement consideration: FCA Customer Assistance, P.O. Box 21-8004, Auburn Hills, MI 48321-8007, Attention: Recall Reimbursement.

Note to lessors receiving this recall notice: Federal regulation requires that you forward this recall notice to the lessee within 10 days.