

060-1625 /
060-1650
Motor Home Entrance
Door Hardware



FEATURES/BENEFITS:

- Inside release is low profile .094" (23.9mm) to allow for close fitting screen doors
- Paddle can be locked before door is shut and is rigid when locked
- Inside assist with open bail for easy closing
- Can be keyed to match other TriMark door products with KeyOne™ Plus for a single-key system, keyed alike or provided non-locking
- Deadbolt locks into the fully extended position for true deadbolt functioning (deadbolt option)
- Ability to be used with power actuation for locking
- Deadbolt cylinder non-removable when locked for added security



AVAILABLE:

- With optional built-in deadbolt
- Master keyed paddle key cylinder and non-master keyed deadbolt key cylinder

MATERIAL:

- Housing, inside plates, handles, deadbolt, locking components including lock knobs: Die cast zinc alloy
- Strike plate: Heat treated and zinc plated steel
- Plunger, load pins and plunger end plates: Steel

FINISH:

- Black powder coated
- Copper-nickel-chrome plated
- Other finishes available upon request

INSTALLATION

- #10-24 UNC mounting screws not included. Recommended torque 10 in-lbs. (1.1 N-m)
- 1/4-20 UNC grade 5-type fasteners for strike plate installation recommended
- Supplied with gaskets already installed
- Sandwich mount installation does not require any linkage rods

U.S. Patent No. 8,733,139

U.S. Design Patent No. D674,678 / D676,304

Designed for RV motor homes and fifth wheel trailer entrance doors, this product has been upgraded with a steel plunger for better security and long life. It features easy installation with through sandwich mounting, a low-profile plunger style latch which is compliant to FMVSS 206, a built-in deadbolt for additional security and is power lockable

DESIGNED FOR:

- Motor home entrance doors with thickness ranging from 1.39" (35.3mm) to 1.78" (45.2mm)
- Different inside handle assemblies are required to facilitate the range of door thicknesses. Please identify when inquiring
- Universal application — can be used in either right or left-hand doors

TriMark Corporation
500 Bailey Avenue
P.O. Box 350
New Hampton, Iowa 50659
United States
Tel: 641-394-3188
Fax: 641-394-2392
1-800-447-0343
www.trimarkcorp.com

TriMark Europe
Cedar Court
Walker Road
Bardon Hill
Coalville LE67 1TU
United Kingdom
Tel: +44(0)1530 512460
Fax: +44(0)1530 512461
www.trimarkeu.com

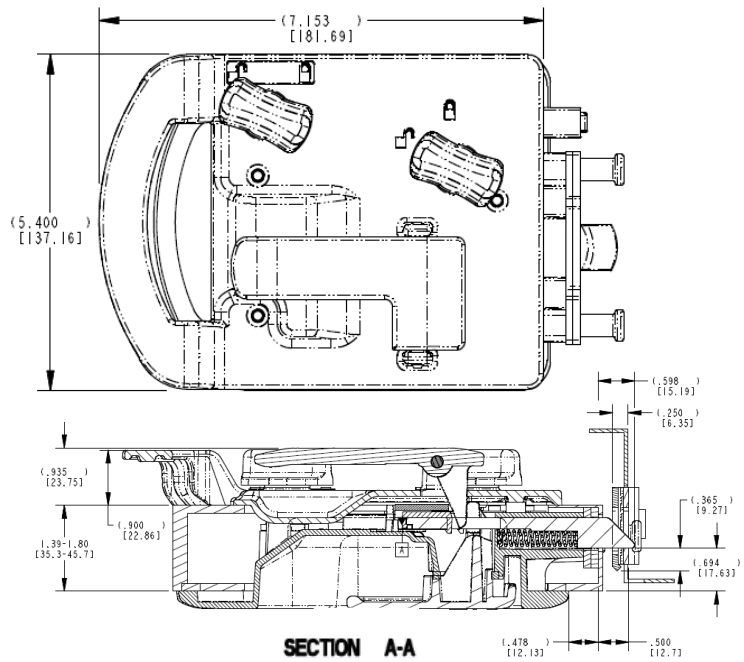
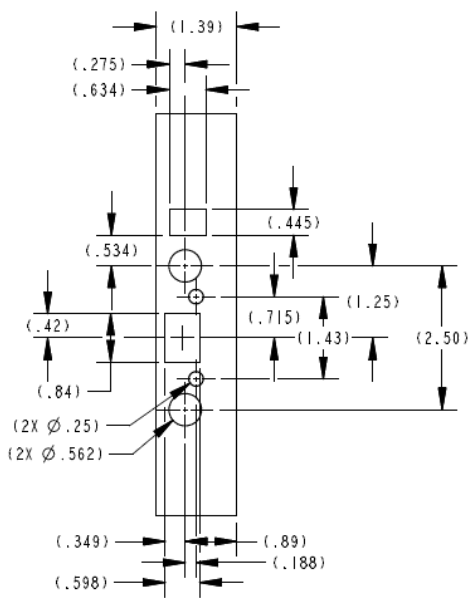
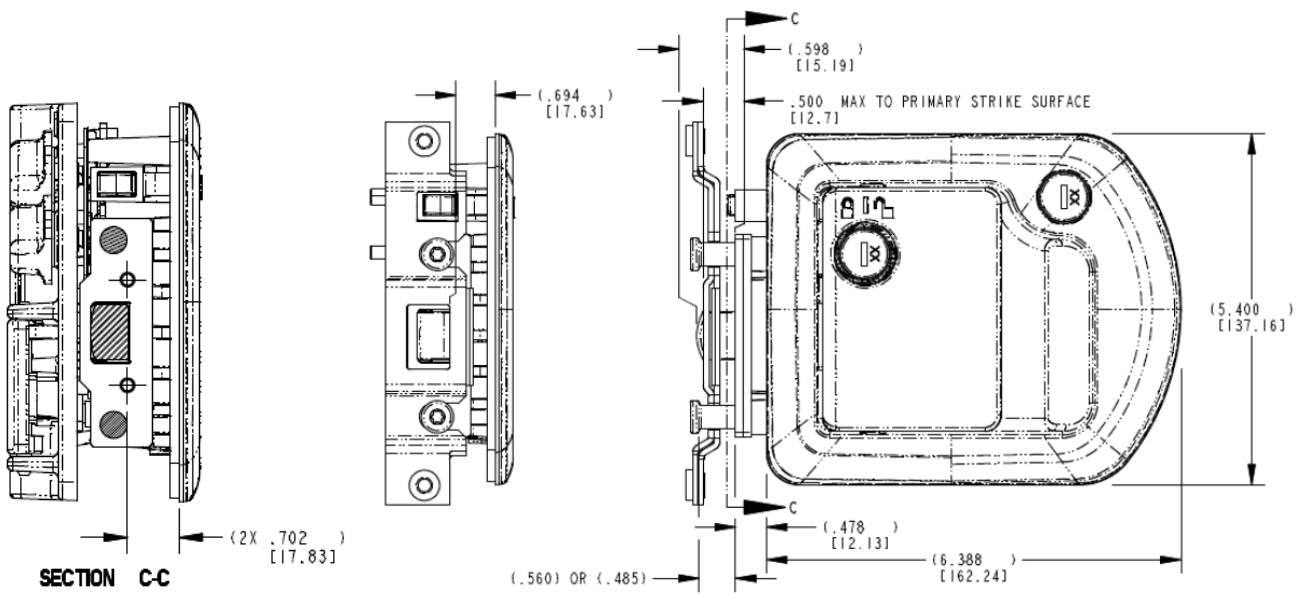

For more information visit
www.trimarkcorp.com

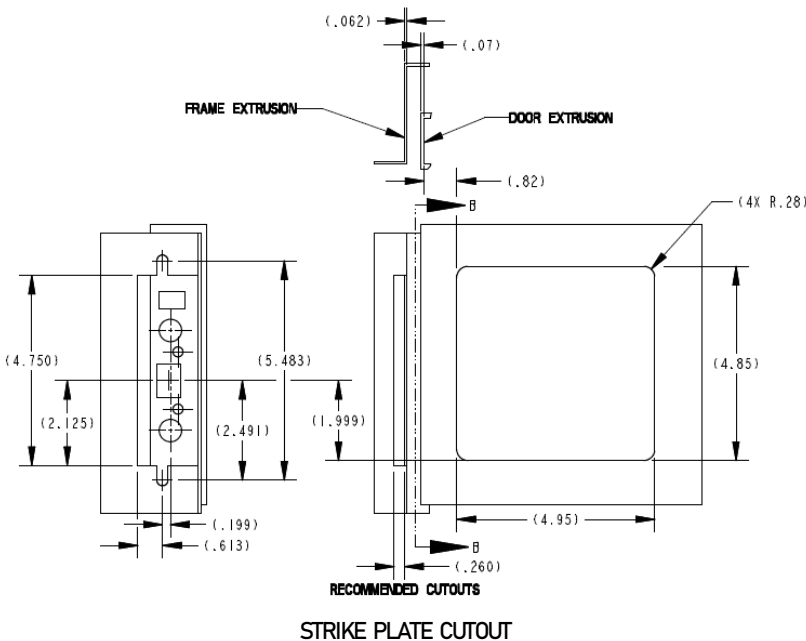

Individual part dimensions are for reference only. Refer to individual part drawings for complete dimensions, specifications, and installation procedures. Engineering assistance and application drawings are available.

Caution: Applications of this handle may fall within the requirements of FMVSS 206 (ECE-R11) and SAE J839 safety standards for on-road and off-road operator entrance doors. These safety related requirements are dependent on door application, e.g. front and rear hinged doors, sliding doors, or hinged upward swinging doors. The entire door hardware system must be included in the design/analysis process latch, handle, lock mechanism, cables/rods/linkages, fasteners, hinges, etc. This ensures compatibility of all components within the hardware system. If FMVSS 206 (ECE-R11) is a requirement, then all of the components within the door system must comply with strength, inertia and locking requirements as specified within the Standard. Note that the 060-1650 Motor Home Entrance Door Hardware complies with FMVSS 206 (ECE-R11) when tested in accordance with SAE J839 and that this product meets FMVSS 206 (ECE-R11) locking requirements and may be used in FMVSS 206 (ECE-R11) applications pending TriMark application approval.