

# **AIR BRAKE HANDBOOK**

# The Air Brake Handbook

For over 60 years, Bendix Commercial Vehicle Systems Company has been a leading supplier of Bendix air-braking systems to the heavy trucking industry. From the first concept of using air as a braking force, years of development and refinement have produced dependable stopping power for thousands of vehicles traveling millions of miles each year.

Our customer-driven approach to business has helped us grow into a global organization with technical and manufacturing centers keeping us on the leading edge of new-development and applications engineering.

Consequently, all Bendix products are backed by a team of highly-trained experts...people ready to provide technical support, systems information or troubleshooting help. Our fully staffed technical hotlines are just a phone call away and ongoing technical training is available as well - both on-site and off.

This manual presents only an overview of the air brake system and its components for more detailed information on systems and components Bendix Commercial Vehicle Systems Company offers the following variety of training aids:

## **ADDITIONAL AIR-BRAKE SYSTEM INFORMATION** **Bendix Audiovisual Programs**

Bendix offers several audiovisual programs on many Bendix air-brake devices and systems. These moderately priced programs are available in 35 mm slide, V.H.S and European P.A.L. formats and describe the operation and troubleshooting of air-brake components and systems. The programs are described in our Sales Promotion & Training Materials Brochure, BW1699, available upon request at no charge. Please send requests to the address shown below.

### **Bendix Air Brake Maintenance Manual**

This maintenance manual consists of instruction and service data sheets and provides complete information on most air-brake system components. In addition to information on how each device operates, the sheets contain information on installation, maintenance and disassembly/assembly instructions.

To order a complete manual, BW9600, contact your local distributor or write to:

**Bendix Commercial Vehicle Systems Company**  
**Advertising & Communications Department**  
**P.O. Box 4016**  
**Elyria, Ohio 44036-2016**

### **Manual Layout**

The products presented in this manual are introduced in a building format. Each device is introduced as it is presented in the system beginning with the compressor of the supply system, building to a complete straight vehicle and then adding the components necessary to build a tractor. Mini systems are presented throughout the manual to assist in the understanding of the application and function of the components.

#### **IMPORTANT!**

The systems presented in this manual are intended for illustrative purposes only and are not intended for actual vehicle piping.

We hope this booklet will provide useful information regarding the application and operation Bendix air-brake devices. Each device shown includes a description of operation, a schematic showing the device in a typical system as well as the DIN representation of the device. The manual is divided into four basic sections: Supply system, service brake system, emergency and parking brake systems and trailer system.

## GENERAL INDEX

| <u>SECTION</u>                         | <u>PAGE NO.</u> |
|--|-----------------|
| <b>Systems</b>                         |                 |
| Supply                                 | 4               |
| Supply & Service                       | 12              |
| Rear Service & Parking Emergency Brake | 19              |
| Spring Brake Anti-Compounding          | 21              |
| Auxiliary                              | 28              |
| Tractor                                | 31              |
| Trailer                                | 44              |
| Towing Trailer                         | 45              |
| Converter Dolly                        | 47              |
| <b>Fundamentals of Brakes</b>          | 48              |
| <b>Fundamentals of Compressed Air</b>  | 52              |
| <b>Air Brake System Balance</b>        | 55              |
| <b>Air Brake System Maintenance</b>    | 57              |

## INDEX BY DEVICE

| <u>DEVICE</u>                     | <u>PAGE</u> | <u>DEVICE</u>                  | <u>PAGE</u> |
|-----------------------------------|-------------|--------------------------------|-------------|
| Air Dryers                        | 10, 45      | Lever Operated Control Valves  | 25          |
| Air Dryer Reservoir Module        | 9           | Limiting Quick Release Valve   | 17          |
| Air Horn                          | 29          | Lock Line Control Valve        | 26          |
| Air Horn Control                  | 29          | Low Pressure Indicators        | 11          |
| Air Start Valves                  | 28          | Park Control Valve             | 24          |
| AntiLock Components               | 41-43       | Park Emergency Control Valve   | 26          |
| AutoBrake                         | 27          | Pilot Operated Push-Pull       | 27          |
| Bobtail Proportioning Relay Valve | 36          | Pilot Relay Valves             | 47          |
| Bobtail Proportioning Valve       | 37          | Pressure Protection Valves     | 28          |
| Bobtail Ratio Valve               | 37          | Push-Pull Control Valves       | 23          |
| Brake Block Lining                | 15          | Quick Release & Double Check   | 21          |
| Brake Chambers                    | 13          | Quick Release Valves           | 17, 21      |
| Compressor Inlet Devices          | 7           | Reducing Valves                | 30          |
| Compressors                       | 5           | Relay Emergency Valves         | 45, 47      |
| Control Valve                     | 27, 32, 47  | Relay Valves                   | 22          |
| Dash Control Modules              | 34, 35      | Reservoir                      | 7           |
| DD-3 Safety Actuator              | 20          | Roto Safety Actuator           | 26          |
| Double Check & Stop Light Switch  | 32          | Rotochambers                   | 13          |
| Double Check Valves               | 18          | Safety Valves                  | 8           |
| Drain Cocks                       | 8           | Shut Off Valve                 | 27          |
| Drain Valves                      | 9           | Single Check Protection Valve  | 10          |
| Electronic Throttle               | 38          | Single Check Valve             | 11          |
| Fan Clutches                      | 30          | Slack Adjusters (Auto, Manual) | 16          |
| Filter                            | 9           | Spring Brake Modulators        | 22          |
| Foot Brake Valves                 | 12          | Spring Brake Valve             | 23          |
| Foundation Brake Assemblies       | 14          | Spring Brakes                  | 19          |
| Friction Material                 | 15          | Stop Light Switches            | 18          |
| Front Axle Ratio Valve            | 18          | Synchro Valve                  | 27, 47      |
| Governor                          | 8           | Tractor Protection Valves      | 33          |
| Hose Couplings (Glad Hands)       | 35          | Trailer Control Valves         | 35          |
| Indication & Shutdown Modules     | 38          | Trailer Spring Brake Valves    | 45, 46      |
| Inversion Valves                  | 20          | Trailer Supply Control Valves  | 32          |

# STRAIGHT VEHICLE



# SUPPLY SYSTEM

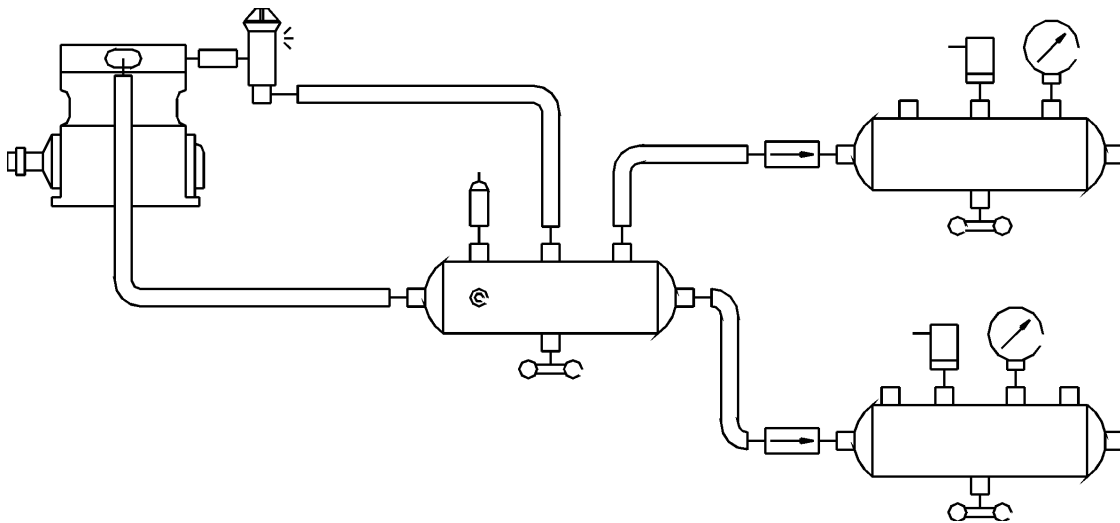

TYPICAL CHARGING OR AIR SUPPLY SYSTEM



**BX-2150**



**DuraFlo 359**

**Single  
Cylinder  
Compressors**



**Tu-Flo 400**



**Tu-Flo 500**



**Tu-Flo 501**

**Two Cylinder  
Compressors**



**Tu-Flo 700**



**DuraFlo 596**



**Tu-Flo 550  
Tu-Flo 750**



**Tu-Flo 1000**



**Tu-Flo 1400**

**Four Cylinder  
Compressors**

## AIR COMPRESSOR

The **air compressor** is the source of energy for the air brake system. It is driven by the vehicle engine, either by belt or drive gear, and on most vehicles, utilizes the vehicle lubrication and cooling system; however, self-lubricated and air-cooled compressors are available in some models.

All Bendix reciprocating type compressors feature automatic inlet and discharge valves and an unloading mechanism.

Several sizes in various mounting configurations to meet a wide range of vehicle needs are available. Refer to the chart below for specific information.

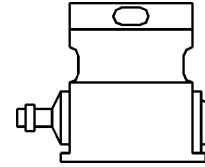

COMPRESSOR

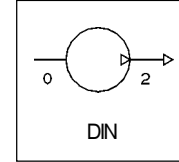

| Compressor Type | Compressor Displacement at 1250 RPM | No. of Cylinders | Lubrication |      | Cooling |       | Typical Application                 | Comments                         |
|-----------------|-------------------------------------|------------------|-------------|------|---------|-------|-------------------------------------|----------------------------------|
|                 |                                     |                  | Engine      | Self | Air     | Water |                                     |                                  |
| Tu-Flo 400      | 7.25                                | 2                | Yes         | Yes  | Yes     | Yes   | Straight air and air/hyd. class 6&7 |                                  |
| BX-2150         | 9.5                                 | 1                | Yes         | No   | No      | Yes   | Straight air and air/hyd. class 6&7 |                                  |
| Tu-Flo 500      | 12                                  | 2                | Yes         | Yes  | Yes     | Yes   | Straight air class 7 & 8            | Becoming Obsolete                |
| Tu-Flo 501      | 12                                  | 2                | Yes         | No   | No      | Yes   | Straight air class 7 & 8            |                                  |
| Tu-Flo 550      | 13.2                                | 2                | Yes         | No   | No      | Yes   | Straight air class 7 & 8            | Replaces most TF 500, 501        |
| Tu-Flo 600      | 14.5                                | 2                | Yes         | No   | No      | Yes   | Straight air class 7 & 8            | Obsolete, replaced by 700, 750   |
| Tu-Flo 700      | 15.5                                | 2                | Yes         | No   | No      | Yes   | Straight air class 7 & 8            |                                  |
| Tu-Flo 750      | 16.5                                | 2                | Yes         | No   | No      | Yes   | Straight air class 7 & 8            | Replaces most TF 600, 700        |
| Tu-Flo 1000     | 24                                  | 4                | Yes         | Yes  | Yes     | Yes   | Special, ie; tank trailer pump-off  | V4 cylinder configuration        |
| Tu-Flo 1400     | 32                                  | 4                | Yes         | No   | No      | Yes   | Special, ie; tank trailer pump-off  | In-line 4 cylinder configuration |
| DF-596          | 27                                  | 2                | Yes         | No   | No      | Yes   | Special, ie; tank trailer pump-off  |                                  |
| DF-359          | 13                                  | 1                | Yes         | No   | No      | Yes   | Straight air class 7 & 8            |                                  |

## INLET REGULATING VALVE

The **inlet regulating valve** or **IRV** is intended for use on multi-cylinder compressors which receive their induction air supply from the pressure side of the engine turbocharger. The IRV **may not** be used in conjunction with single cylinder compressors including the BX-2150. The IRV which is generally mounted to the compressor inlet is designed to regulate compressor inlet pressure to 10 PSI or less. The outlet flange of the IRV will mount to all Bendix Tu-Flo Compressors except the Tu-Flo 300.



INLET REGULATING VALVE

## ST-4 SAFETY VALVE

The **ST-4 Safety Valve** is installed the extra compressor discharge port if available, or in the discharge line to prevent compressor damage in the event of discharge line blockage. Because this valve is specifically designed for this application a standard safety valve may not be used in lieu of the ST-4.



ST-4

## INLET CHECK VALVE

The **inlet check valve** may be used on naturally aspirated compressors to prevent oil misting during the unloaded cycle. The inlet check valve mounts to the intake side of the compressor and must be used in conjunction with an inlet valve stop or inlet adapter.



INLET CHECK VALVE

## RESERVOIR

The **reservoir** serves the air brake system as a storage tank for a volume of compressed air. The reservoir is sized by the vehicle manufacturer to provide an adequate volume of air for use by the braking system and auxiliary control devices. Generally, more than one reservoir is used in air brake systems. A secondary function of reservoirs is to provide a location where the air heated by compression, may be cooled and the water vapor condensed.

Bendix reservoirs are built in accordance with SAE specifications and are available in various sizes in both single and double compartment design configurations, and are certified per FMVSS 121.



RESERVOIR

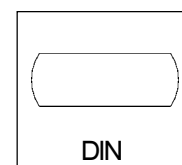
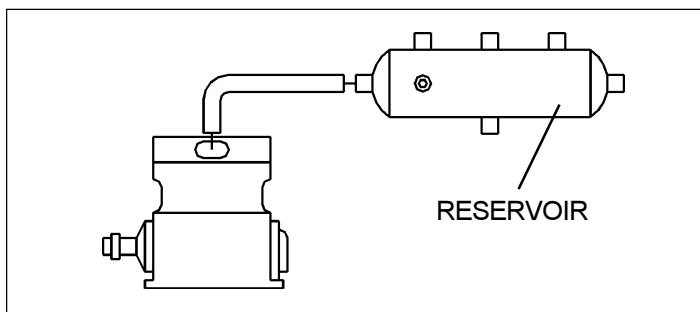

## SAFETY VALVE

The **safety valve** protects the air brake system against excessive air pressure buildup. It must be installed in the same reservoir that the compressor discharge line is connected to. Safety valves are available in both adjustable (ST-1) and non-adjustable (ST-3) styles, in various pressure settings, and with either 1/4" or 3/8" N.P.T.



ST-1



ST-3

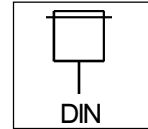

## GOVERNOR

The **governor** operates in conjunction with the compressor unloading mechanism and maintains reservoir air pressure between a predetermined maximum and minimum pressure.

The D-2 governor is an adjustable piston-type valve available in various pressure settings. A non-adjustable pressure range between specified cut-in and cut-out pressures is designed into the D-2 governor. Provisions are made for direct mounting to the compressor or for remote mounting if desired. The D-2 governor is available in weatherproof and high temperature versions for special installations. The D-2A is a non-adjustable version of the D-2 governor.

The **D-2/SV-1 governor module** is for use with the DuraFlo™ 596 compressor. The module offers convenient installation of the required components in a single, factory pre-assembled component group and provides for either direct mounting to the compressor or remote mounting as required by a specific application.

The module is primarily intended for use when changing over to (retrofitting) the DuraFlo 596 compressor.



D2 / SV-1



D-2A



D-2

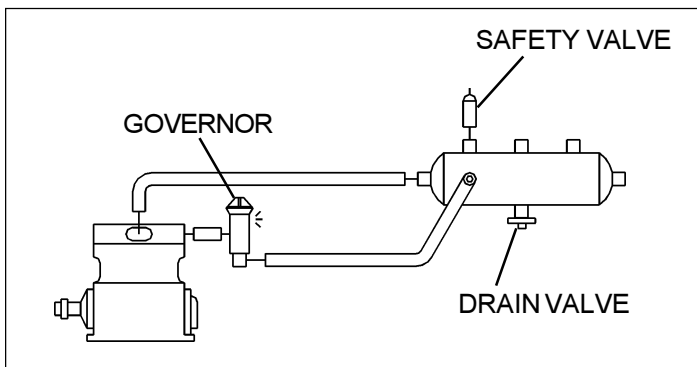
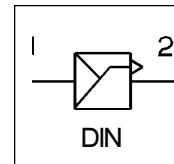

## RESERVOIR DRAIN DEVICES

**Reservoir draining devices** are installed in air-brake reservoirs. They allow the accumulation of contaminants collected in the reservoir to be drained off to atmosphere, and are available in both manual and automatic styles.

**Manual draining devices** consist of drain cocks which require manual operation at the point at which they are installed. Drain Cocks are available in various styles with pipe thread sizes of 1/8", 1/4" and 3/8".



DRAIN COCK



## DRAIN VALVES

The **DV-2 automatic reservoirs drain valve** is a completely automatic draining device. It is installed directly into the end or bottom drain port of the reservoir and does not require any additional control lines. It operates automatically from ascending and descending reservoir pressures. It is available in either the end port or bottom port version, and with or without a 12v or 24v heater.

The **DV-1 remote control drain valve** consists of a drain valve installed into the reservoir and a control valve such as the **RD-2** which is installed within the cab of the vehicle or any convenient servicing point.



**DV-1  
DRAIN VALVE**



**DV-2  
DRAIN VALVE**



**RD-2**

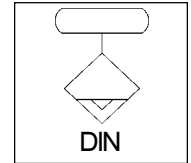

**DIN**

## EVERFLOW™ MODULE

The **EverFlow™ Air Dryer Module** when used in an air dryer system is intended to remove moisture and other contaminants normally found in the air brake system. The air dryers are plumbed in parallel, splitting from a common compressor discharge line, then recombining to a common delivery line to the compressors.

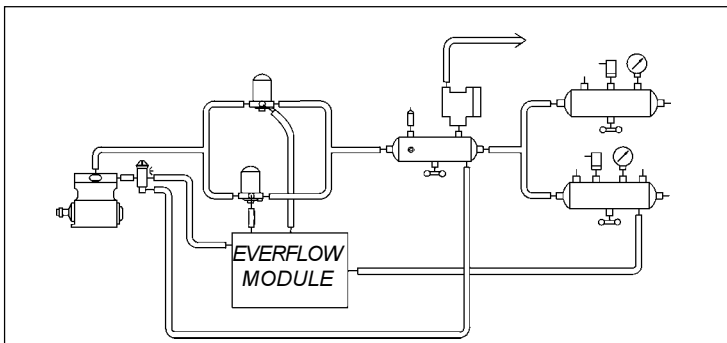

**EverFlow Module**

## PURAGUARD

The **PuraGuard System Filter** is used to assist the production of purified compressed air on high air use vehicles. The PuraGuard System Filter consists of a filter element mounted in a die cast aluminum housing. The Sump Housing contains a drain valve for maintenance.

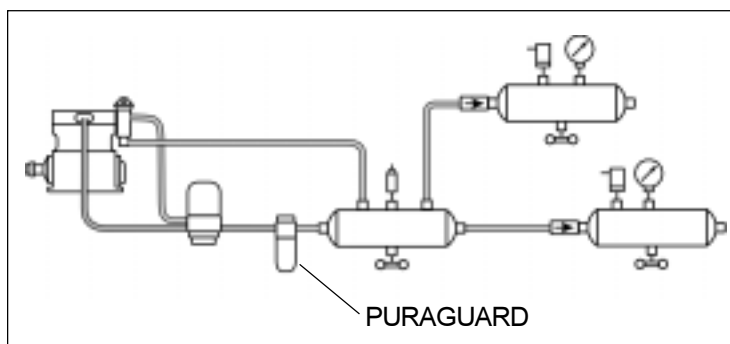

**PURAGUARD**



**PuraGuard**

## AIR DRYERS

The **air dryer** is a desiccant type in-line filtration system that removes both liquid and water vapor from the compressor discharge air before it reaches the air brake reservoirs. This results in only clean, dry air being supplied to the air brake system, aiding in the prevention of air line freezeups.

The air dryer utilizes a replaceable desiccant material which has the unique ability to strip water vapor from moisture laden air. The desiccant material is regenerative, in that its adsorptive properties are renewed each time the compressor is unloaded.

The air dryer end cover is equipped with an automatic drain valve, controlled by the air system governor and is equipped with an integral heating element and is available for either 12 or 24 volt systems.

The AD-2, AD-3, AD-4, AD-9 and AD-IP air dryers are equipped with an integral storage of dry air for the purge cycle (purge volume). The AD-IP EP includes an extended purge volume. The AD-SP uses a small amount of air from the supply and front axle (secondary) reservoirs to perform the purge function. Because of this difference the AD-SP is considerably smaller and lighter than the integral purge dryers.

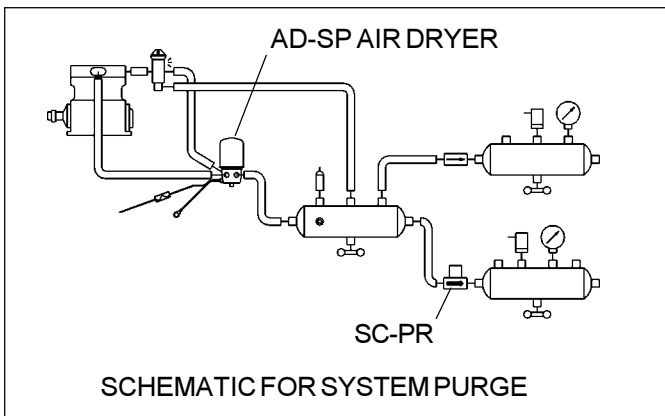
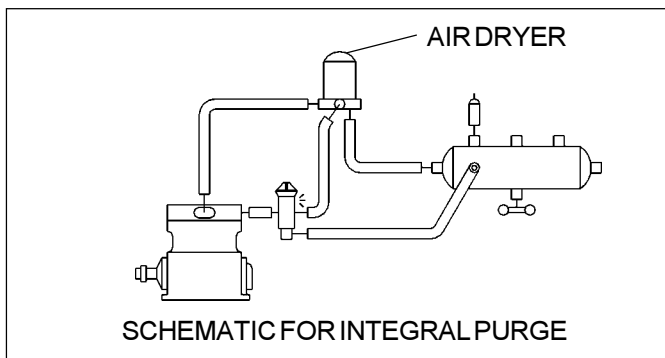

## SINGLE CHECK PROTECTION VALVE

The **SC-PR single check protection valve** is a combination of 2 separate devices, a single check valve and a pressure protection valve. It serves as a means of protecting the air pressure in the front axle service reservoir and replaces the standard single check valve. The SC-PR must be used in conjunction with the AD-SP Air Dryer.



AD-3



AD-9

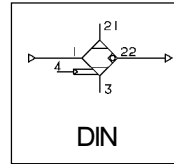

AD-4



AD-2

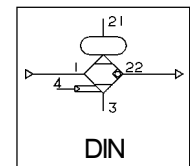
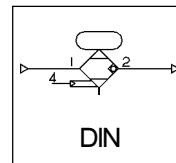

AD-IP



AD-IP EP



SC-PR



AD-SP

## DRM

The function of the **Dryer Reservoir Module (DRM)** is to provide heavy vehicles with an integrated vehicle Air Dryer, Secondary Reservoir, purge reservoir, governor and a number of the charging valve components in a module. The DRM includes an **Integrated Solution Air Dryer (AD-IS)**, a reservoir (including a separate purge reservoir section) a governor and four pressure protection valves. These have been designed as an integrated air supply system.

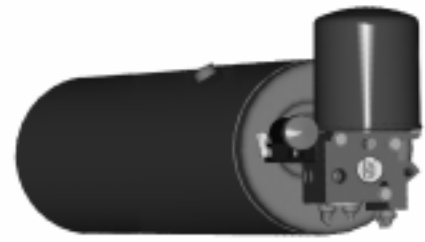

DRM

## SINGLE CHECK VALVES

The in-line **single check valve** allows air flow in one direction only, preventing the flow of air in the reverse direction. Many styles of single check valves are available with either integral or replaceable seats, rubber and metal seats, and with ball or disc valves. Several sizes and configurations are available to accommodate various piping arrangements.

See double check valves page 17 and pressure protection valves page 27.

SC-1  
SINGLE CHECK

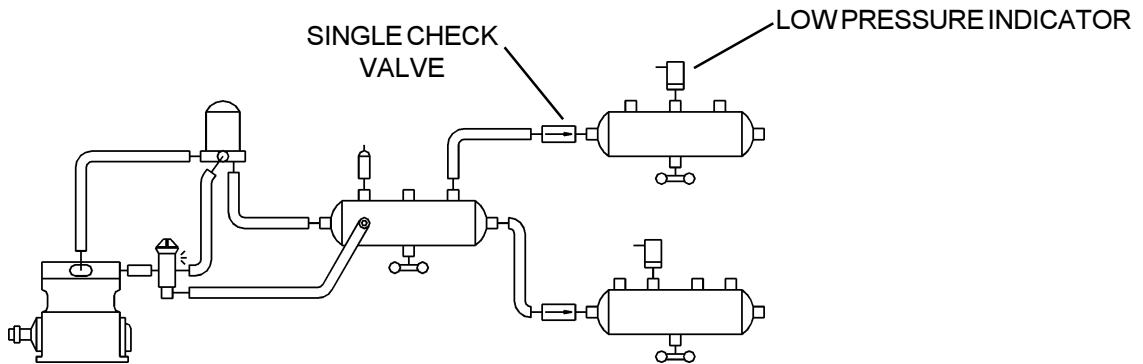
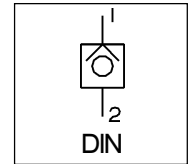

## LOW PRESSURE INDICATOR

**Low pressure indicators** are pressure operated electro-pneumatic switches that are designed to complete an electrical circuit and actuate a warning light and buzzer for the driver in the event air pressure in the service brake system is below a safe minimum for normal operation. The low pressure indicator is available in various pressure settings, is not adjustable, and is generally used in conjunction with a dash mounted warning lamp or warning buzzer or both.



DIN



LP-3

LP-2

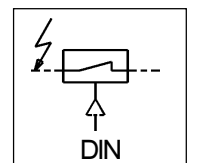

# SUPPLY & SERVICE SYSTEMS

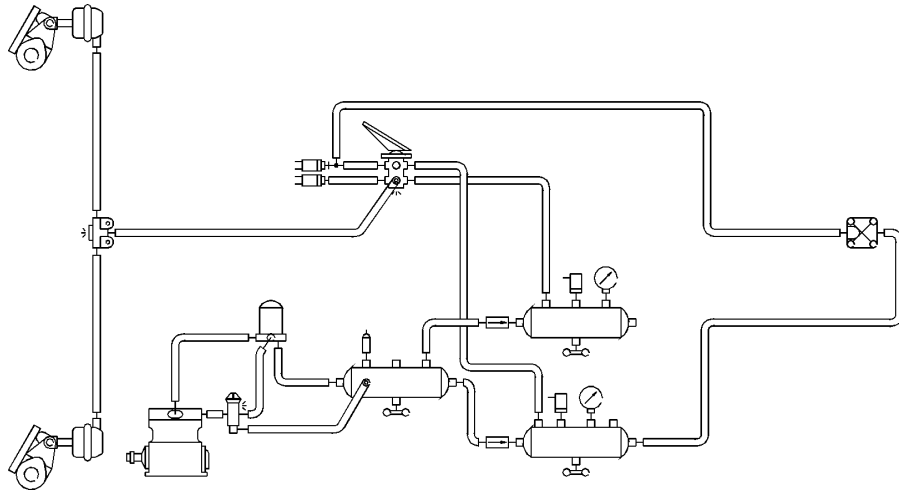

## DUAL CIRCUIT BRAKE VALVE

**Dual circuit brake valves** utilize two separate supply and delivery circuits for service and secondary braking. The number one or primary circuit portion is mechanically operated through the action of the treadle/pedal and plunger. The number two or secondary circuit normally operates similar to a relay valve, with control air delivered from the number one primary circuit. In the emergency mode (failure of the primary supply), the secondary inlet valve is mechanically opened by a push through mechanical force from the driver's foot via the treadle/pedal, plunger and primary piston.

The **E-6, E-8P, E-10P, E-10, E-12 and E-15 dual brake valves** are floor mounted, treadle operated valves with two separate supply and delivery circuits.

The **E-7 and E-14 dual brake valves** are firewall mounted, suspended pedal valve with two separate supply and delivery circuits. Threaded supply and delivery ports for both circuits are provided at the back of the valve. For engine side firewall connections, an optional manifold is available.

The **E-10PR Retarder Control Brake Valve** is used with retarder systems installed on automatic transmissions. Automatic transmission retarders are used to retard forward motion of the vehicle above 5 mph. Retarders are most popular in the transit (busses/coaches) industry and are used to extend the life of brake system components.

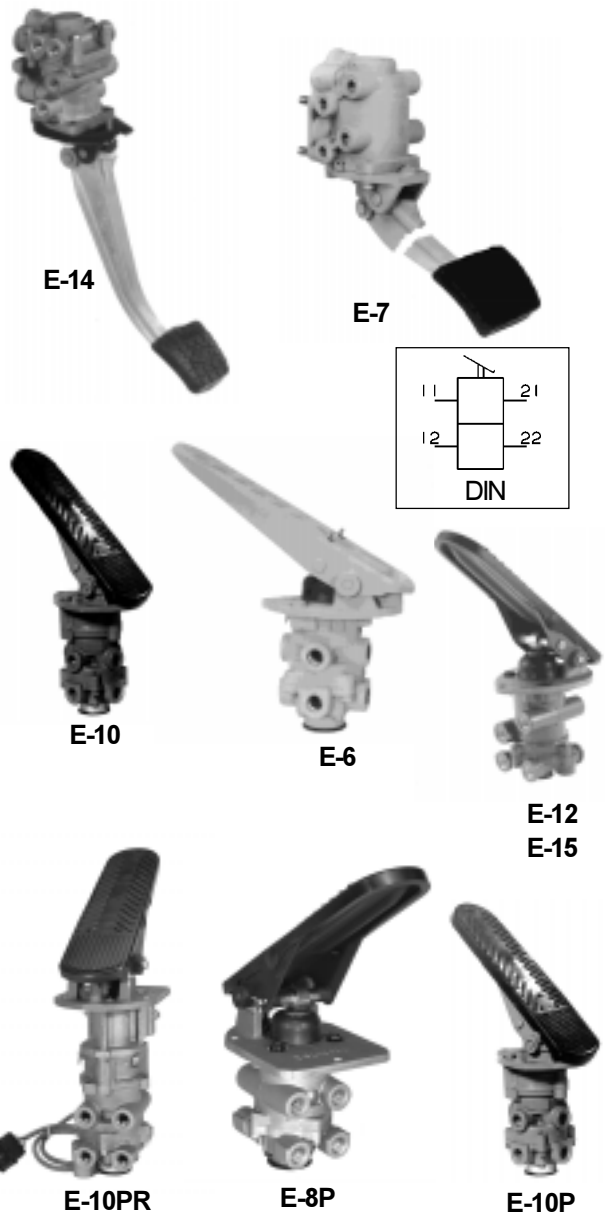
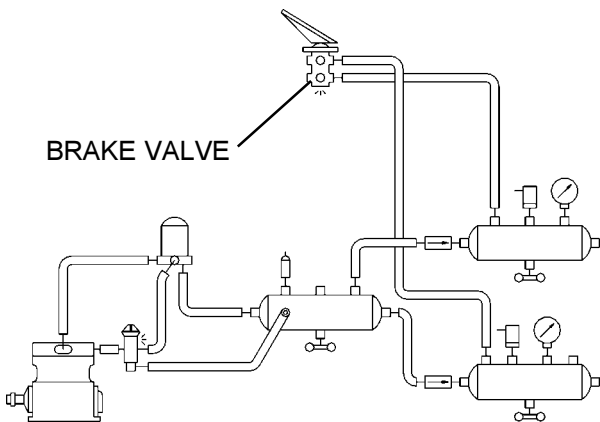

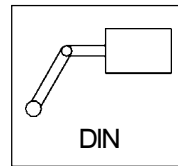
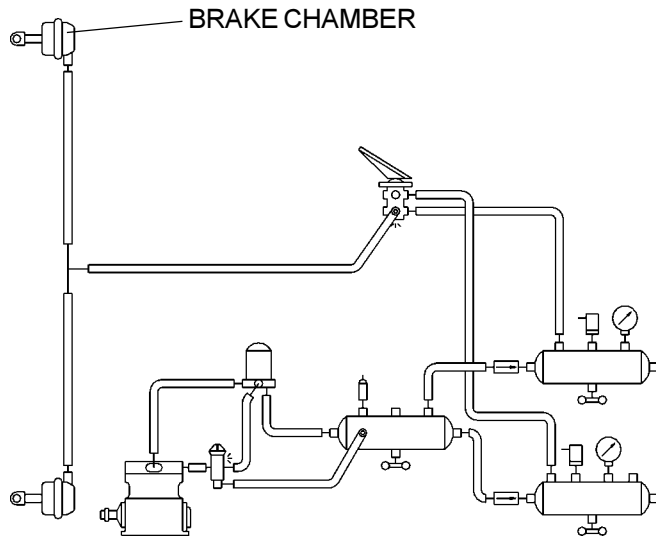

**BRAKE CHAMBER**

**ACTUATORS**

**Brake chambers** and slack adjusters convert the energy of compressed air into mechanical force and motion. This actuates the brake camshaft which in turn operates the foundation brake mechanism forcing the brakes shoes against the brake drum.

Brake chambers are available in several sizes, providing a wide range of output forces and strokes. Different size brake chambers are identified by numbers which specify the effective area of the diaphragm. A Type 30 brake chamber has 30 square inches effective area.

**Rotochambers** are also available in several sizes, providing a wide range of output forces. The rolling type diaphragm provides long life and gives a constant output force throughout the entire stroke. Rotochambers are frequently used in industrial applications.



**ROTOCHAMBER**

**BRAKE CHAMBER SPECIFICATIONS**  
Dimensions in inches  
**CLAMP TYPE BRAKE CHAMBER**

| Type | Effective Area (sq.in.) | Outside diameter | Maximum stroke | Maximum stroke at which brakes should be adjusted |
|------|-------------------------|------------------|----------------|---|
| 6    | 6                       | 4 1/2            | 1 5/8          | 1 1/4   |
| 9    | 9                       | 5 1/4            | 1 3/4          | 1 3/8   |
| 12   | 12                      | 6 11/16          | 1 3/4          | 1 3/8   |
| 16   | 16                      | 6 3/8            | 2 1/4          | 1 3/4   |
| 20   | 20                      | 6 25/32          | 2 1/4          | 1 3/4   |
| 24   | 24                      | 7 7/32           | 2 1/4          | 1 3/4   |
| 30   | 30                      | 8 3/32           | 2 1/2          | 2   |
| 36   | 36                      | 9                | 3              | 2 1/4   |

Chamber stroke with brakes adjusted should be as short as possible without brakes dragging.

**ROTOCHAMBER SPECIFICATIONS**  
Dimensions in inches

| Type | Effective Area (sq.in.) | Outside diameter | Maximum stroke | Maximum stroke at which brakes should be adjusted |
|------|-------------------------|------------------|----------------|---|
| 9    | 9                       | 4 9/32           | 2              | 1 1/2   |
| 12   | 12                      | 4 13/16          | 2              | 1 1/2   |
| 16   | 16                      | 5 13/16          | 2 1/2          | 1 7/8   |
| 20   | 20                      | 5 15/16          | 2 1/2          | 1 7/8   |
| 24   | 24                      | 6 13/32          | 2 1/2          | 1 7/8   |
| 30   | 30                      | 7 1/16           | 3*             | 2 1/4   |
| 36   | 36                      | 7 5/8            | 3 1/2*         | 2 5/8   |
| 50   | 50                      | 8 7/8            | 4*             | 3   |

Maximum chamber stroke with brakes adjusted should be as short as possible without brakes dragging.

\*Available in 6" stroke chambers.

## FOUNDATION BRAKE

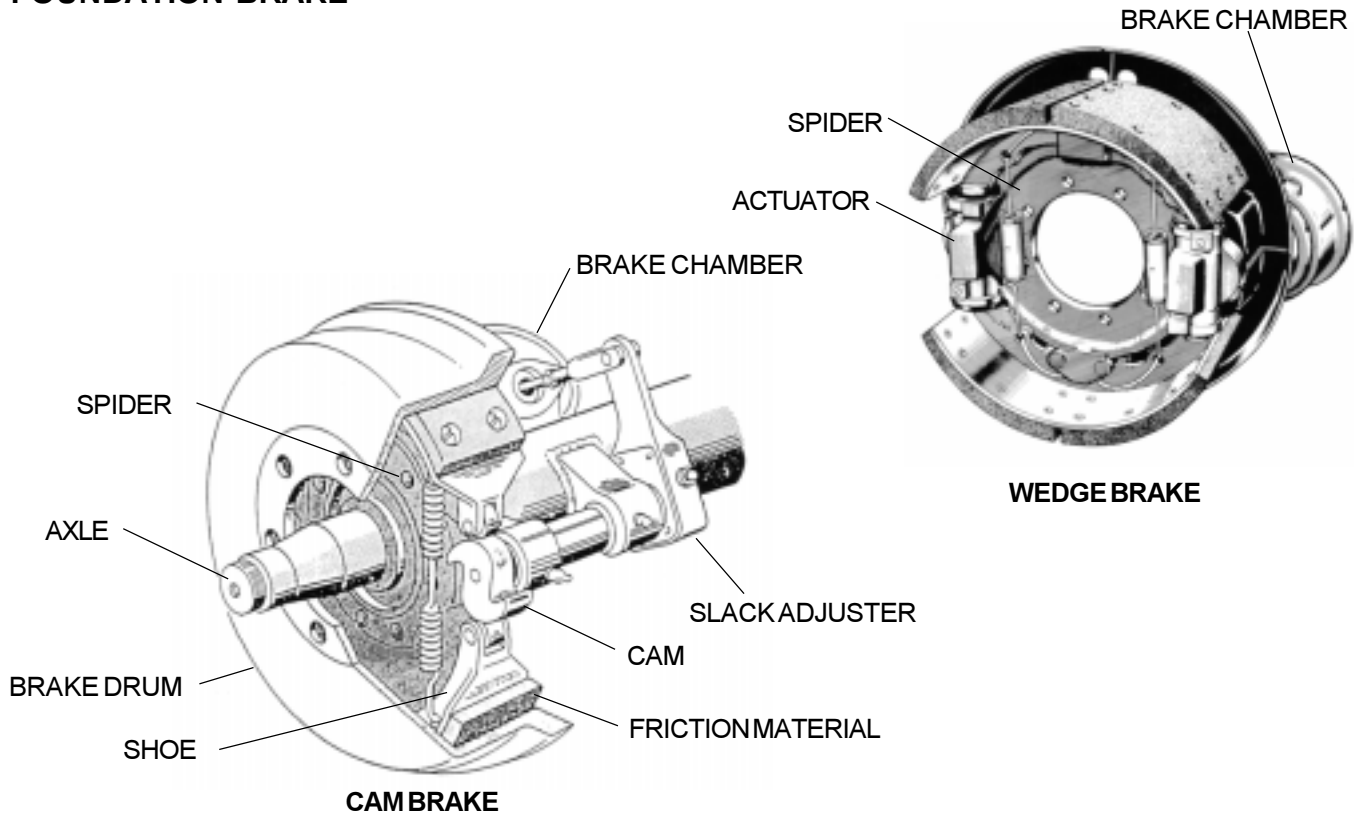

### FOUNDATION BRAKE

The foundation brake is the actual braking mechanism located at each end of the axle. It generally consists of the air or spring actuator, slack adjuster or wedge assembly, the mechanical brake mechanism including the shoes and attached friction material and the brake drum.

### CAM BRAKE

In a cam type foundation brake the pneumatic system is linked to the foundation brakes by the slack adjuster. The arm of the slack adjuster is fastened to the push rod of the chamber with a yoke. The spline of the of the slack adjuster is installed on the brake cam shaft. The slack adjuster is a lever, converting linear force of the chamber push rod into a torsional or twisting force needed to apply the brakes.

When torque is applied to the cam shaft, the "S" shaped cam spreads the brake shoes, forcing the brake lining into contact with the brake drum stopping the vehicle.

Cam brakes are offered in various diameters to meet vehicle braking requirements, with the most commonly encountered being 16 1/2". The cam brake is "leading-trailing" shoe design with fixed anchor points for each shoe, opposite the cam end of the shoe.

### WEDGE BRAKE

Although the S-cam foundation brake is the most common foundation brake in use today, some vehicles are equipped with the wedge type foundation brake. In this brake, the slack adjuster and cam shaft are replaced by a wedge/roller mechanism that is used to spread the brake shoes and force them against the drum.

The air (spring) chamber is attached directly to the brake spider and the wedge and roller actuation mechanism is enclosed within the actuator and chamber tube. A self adjusting mechanism is standard and is contained within the wedge brake actuator. Bendix wedge brakes are offered in Twinplex®, non-servo and heavy duty non-servo versions. All are 15" diameter and feature a floating shoe design which imparts a higher degree braking efficiency when compared to the cam brake. The Twinplex® is a twin leading shoe (either direction) design. With the appropriate friction material and air actuators the 15" wedge brake is capable of the same stopping power as a 16 1/2" cam brake but is considerably lighter and has the advantage of a "built-in" self adjusting mechanism.

## BRAKE BLOCK AND LINING

Although it takes a 450 hp engine approximately 90 seconds to accelerate a 40 ton vehicle to 55 miles per hour, it should only take 5 seconds to come to a stop. Accomplishing this task takes the right combination of a braking system, which supplies the power and the foundation brakes, which do the actual braking.

When brakes are applied the friction material contacts the brake drum producing heat energy. For optimal performance the heat that is generated must dissipate rapidly to prevent damage to the friction material. Therefore the friction material used in the brake must have the capability of withstanding the heat until dissipated through the drum. It takes the right combination of ingredients to formulate the friction material that provides all the desirable characteristics, including long life.

All friction material is identified by a stencil on its edge. This identification code consists of the name of the manufacturer, the formula identification and the friction class. The friction class is indicated by two letters. The first letter represents the normal coefficient of friction, and the second represents the hot coefficient of friction. The numerical range is shown below.

Friction material selection is dependent upon how the driver uses the brakes, the terrain, vehicle load, etc. The various formulations of material are designed to meet the needs of these conditions. For example a vehicle performing heavy duty operations on rugged terrain may benefit by using a "premium" material designed for high heat situations instead of a "standard" material designed for lighter duty operations.

Brake lining and block differ in that it takes two brake block to line one shoe while a single brake lining segment is all that is required to do the same job. Block is generally 3/4" thick and used on class 8 vehicles while lining is 1/2" thick and generally used on smaller vehicles.

While it is recommended that a matching set of lining be used on each wheel, under some conditions a combination of different lining material may be desirable. If a brake system is marginal, for example, a full step up to a higher grade lining may give an excessively large capacity. In this event using a combination of blocks should be considered. There are various methods of combining different block formulas, but the most practical method is to install the higher grade block on the leading or forward brake.

FRICITIONCODECHART

| LETTER | NUMERICAL RANGE              |
|--------|------------------------------|
| D      | Over .150 But less than .250 |
| E      | .250 to .350                 |
| F      | .351 to .450                 |
| G      | .451 to .550                 |
| H      | Over .550                    |

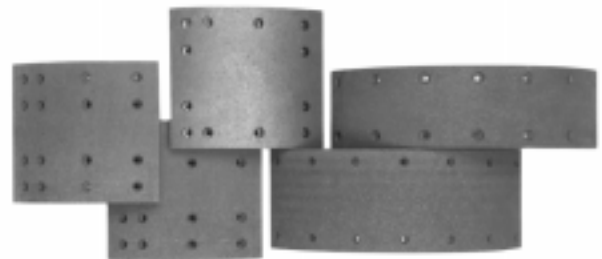

BRAKE BLOCK

BRAKE LINING

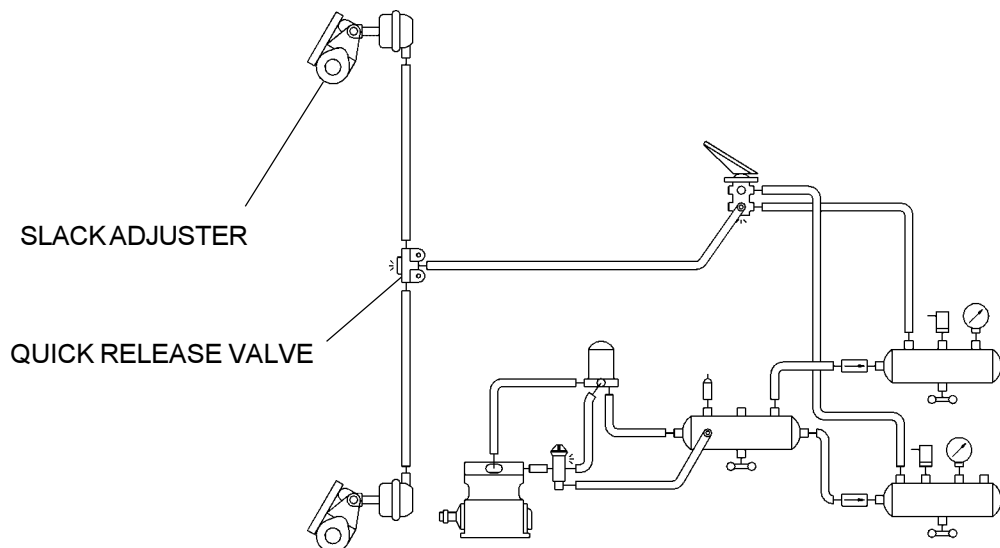

## MANUAL SLACK ADJUSTER

The **slack adjuster** is the link between the brake chamber or actuator and the foundation brake camshaft. It transforms and multiplies the force developed by the chamber into a torque which applies the brakes via the brake camshaft. Slack adjusters are equipped with an adjusting mechanism, providing a means of adjusting for brake lining wear. Slack adjuster models are designated by a number which represents its maximum torque rating (i.e. a type 20 unit is rated for a maximum of 20,000 inch pounds of torque). Slack adjusters are available in various arm configurations, lengths and spline types.

**MANUAL SLACK ADJUSTER**



## AUTOMATIC SLACK ADJUSTER

**Automatic slack adjusters** perform the same function as the standard unit, except that it automatically adjusts for lining wear. The Bendix "sure stroke" unique design monitors brake lining to brake drum clearance, thus eliminating the possibility of over adjustment.

The entire slack adjuster operates as a unit, rotating as a lever with the brake cam shaft as the brakes are applied or released. The most efficient braking action is obtained when the slack adjuster arm travel is minimal, therefore, it is important that brake adjustments are made as often as necessary. The automatic slack adjuster does not require periodic manual adjustment, however, the unit does provide for manual adjustment. All Bendix slack adjusters incorporate a grease fitting and/or a tapped hole for a fitting. The ASA-5 is designed to fit most truck/tractor and trailer applications, while the ASA-3 is intended for use where linkage interference is a problem.

**ASA-5**



## IDEAL ASA-5 INSTALLATION

The brake chamber push rod and arm of the slack adjuster should reach 90 degrees at 1/2 the available stroke (mid-stroke) of the chamber. The ASA-5 has quite a large installation tolerance as illustrated by the chart below.

| Slack Arm Length | X"            |
|------------------|---------------|
| 5.0              | .75" to 2.00" |
| 5.5              | .75" to 2.00" |
| 6.0"             | 0.0" to 2.00" |

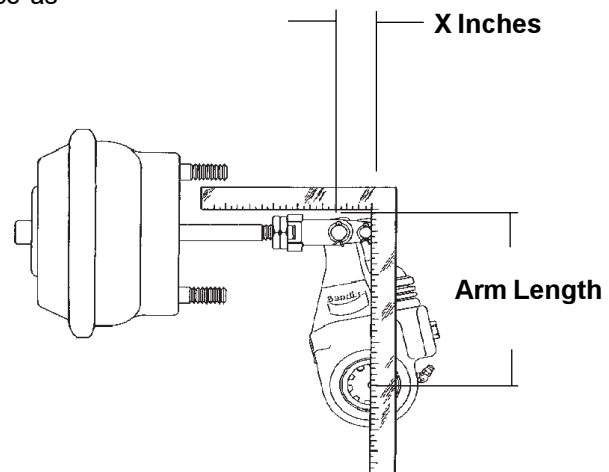



## QUICK RELEASE VALVE

The function of the **quick release valve** is to speed up the exhaust of air from the air chambers. It is mounted close to the chambers it serves. In its standard configuration, the valve is designed to deliver within one psi of control pressure to the controlled device; however, for special applications the valve is available with greater differential pressure designed into the valve.

Three styles of quick release valves are available and are functionally the same. The **QRV** valve is the oldest design and utilizes a die cast metal body with an internal diaphragm, spring and spring seat. The **QR-1** also has a die cast body and diaphragm but does not employ a spring or spring seat. The **QR-N** and **QRN-2** are nonmetallic versions of the **QR-1**. The **QRN-2** is the only non-serviceable version.

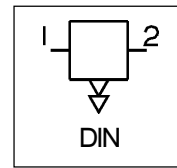

QRV



QR-1



QRN-2



QR-N

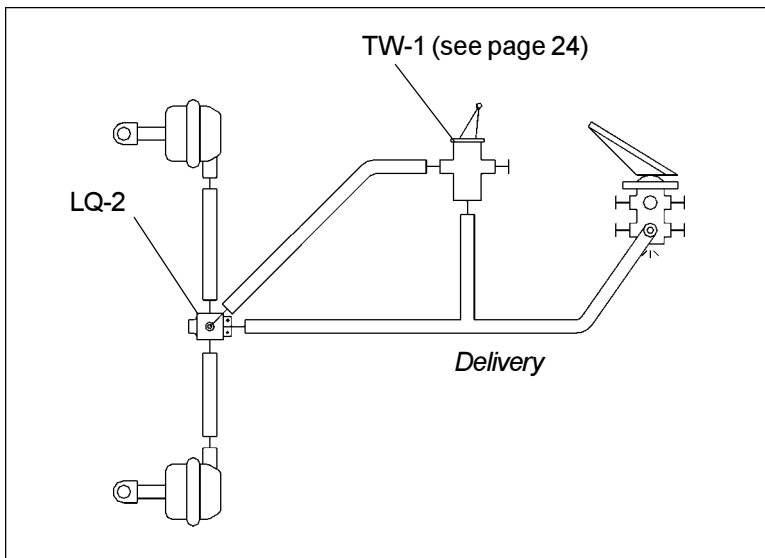

## LIMITING AND QUICK RELEASE VALVE

Commonly found on pre-121 vehicles, and usually mounted on the front axle, the **LQ-2 limiting and quick release valve** serves two functions; the valve limits front axle service brake application by 50% and serves as a quick release valve for that axle. It is controlled by a TW-1 control valve on the vehicle dash, which allows it to be placed in the 50% limiting (slippery road) position or in the normal (dry road) position. In the normal (dry road) position, it will deliver full application pressure.

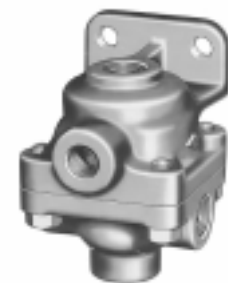
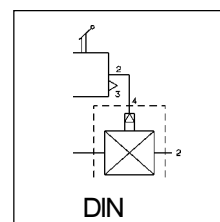

LQ-2

## RATIO VALVE

The **LQ-4 ratio valve** was designed to replace the LQ-2 limiting and quick release valve in the front axle delivery line of vehicles meeting FMVSS 121. During normal service brake applications, the LQ-4 automatically reduces application pressure to the front axle brakes, however, as brake application pressure is increased the percentage of reduction is decreased until at approximately 60 psi (depending upon valve design) full pressure is delivered. The valve is available with several different "hold-off" pressures which prevent the front brakes from operating until the "hold-off" pressure is exceeded.

The obsolete LQ-3 Ratio Valve appears identical to the LQ-4 with minor differences in porting size.

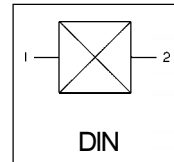
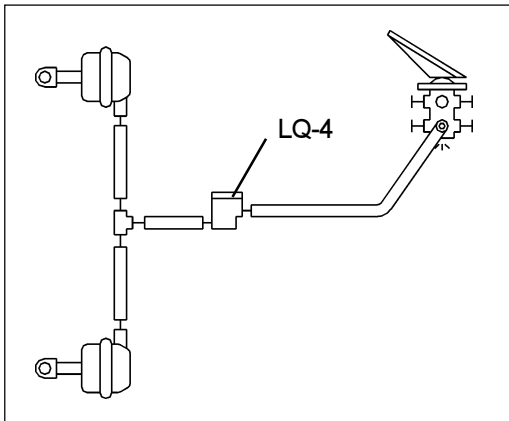

## DOUBLE CHECK VALVES

A **double check valve** is used in the air system when a single function or component must be controlled by either of two sources of pressure. The double check valve will always transmit the higher of the two pressure sources to the outlet port. Double check valves are available in both disc and shuttle types and in various configurations for various applications. It is recommended that double check valves be mounted so that the shuttle operates horizontally.

**DC-4  
Double Check**

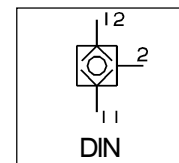

## STOP LAMP SWITCHES

The **SL-4 and SL-5 stop lamp switches** are pressure sensitive electro-pneumatic switches installed in the service application system. They operate the vehicle stop lamps, completing an electrical circuit and lighting the stop lamps each time a brake application is made.

See page 31 for the DS-2 Double Check and Stop Light switch.



**SL-4**



**SL-5**

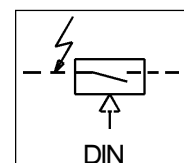

# REAR SERVICE & PARKING EMERGENCY BRAKE SYSTEMS

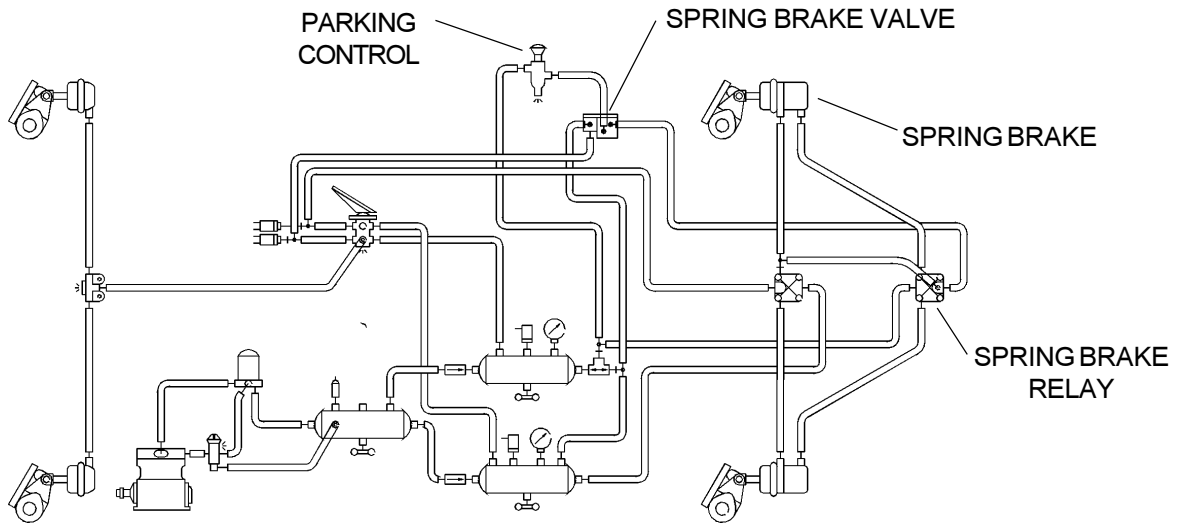

## SPRING BRAKE

The **SB-4 spring brake** actuator is composed of separate air and mechanical actuators in a single housing. Mounted at the wheel of the rear axles it functions as a service, parking and emergency brake. Connected to the service brake valve, the air applied portion of the actuator functions as the service brake. The mechanical portion of the actuator contains a powerful spring which is compressed or released using air pressure. The spring brake therefore contains two actuators which use air pressure in opposite ways. The service actuator requires air pressure to apply the brakes, while the park or emergency actuator uses air pressure to release the brakes.

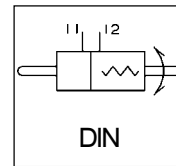

**SPRING BRAKE**

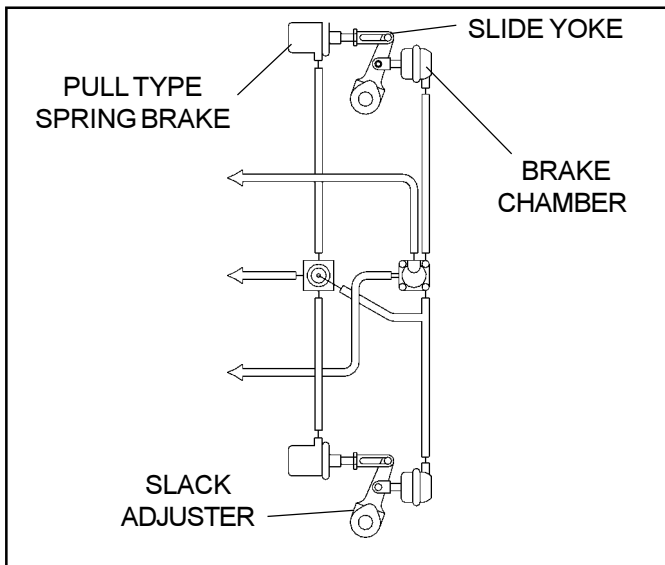

**SB-1  
SPRING BRAKE**

The **SB-1 spring brake actuator** is a pull type, remote-mounted air cylinder that is used as a parking brake. Pressurized air in the chamber compresses the springs when the brake is released. When the air is exhausted, the spring force applies the brake.

## SAFETY ACTUATOR

The **DD-3 safety actuator** is a double diaphragm brake actuator with three functions; service braking, emergency braking and parking. The DD-3 features a mechanical roller locking mechanism for parking and is used extensively on transit and intercity buses. Because of its unique locking roller mechanism, the DD-3 requires the use of special control valves such as the TR-2 Inversion Valve. Various piping configurations have been designed to meet specific vehicle applications. The DD-3 is available in type 24 and type 30 sizes.



**DD-3  
DOUBLE DIAPHRAGM  
SAFETY ACTUATOR**

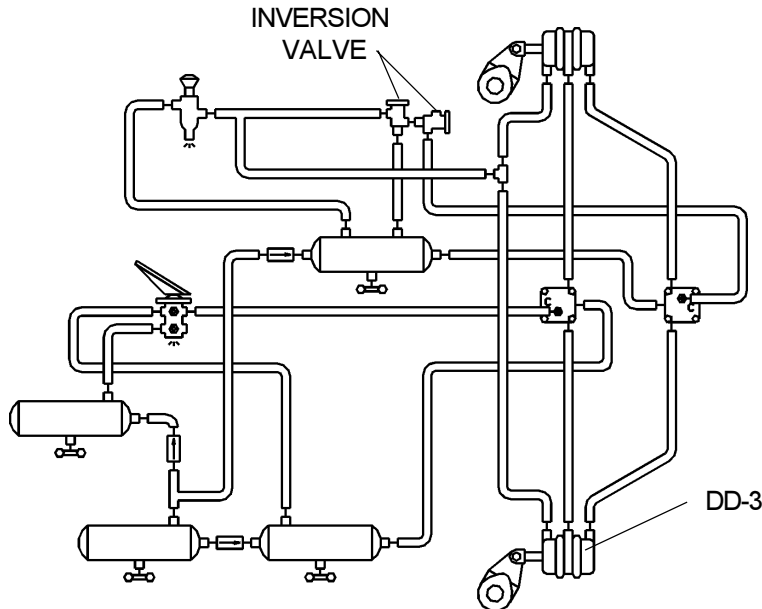

## INVERSION VALVES

**Inversion valves** are air operated control valves, and unlike most control valves are normally open, i.e.; without control pressure the supply is common to the delivery. The inversion valve is closed by using air pressure from another source and is primarily used in emergency or parking brake systems which operate with air from an isolated reservoir. The valve is also used in interlocking and sequencing applications, where the operation of components must take place in specific sequence.

The **TR-2** was designed primarily for use in early DD-3 Safety Actuator installations. It is equipped with a threaded body and nut for mounting.

The **TR-3** is also used extensively in DD-3 systems but is also used in interlocking applications. Two mounting holes are provided for mounting.



**TR-2**



**TR-3**

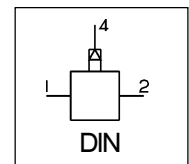

## SIMPLE SPRING BRAKE ANTI-COMPOUND SYSTEM

### GENERAL OPERATION

Brake compounding can occur in a spring brake parking system due to the mechanical and pneumatic nature of the chamber. It will occur in unprotected systems when parking AND service brake applications are made at the same time. An example of this situation occurs when a vehicle is parked on a steep incline; the driver holds the service brakes applied (preventing the vehicle from rolling backward), then actuates the park control which "sets" or applies the spring brakes. For a brief time, the air applied service brakes and the mechanical spring brakes both exert a braking force on the slack adjusters and foundation brakes. The forces of the spring and air applications are additive and can cause damage to the foundation brake components (cam shaft splines, shoes, drum, etc.) and/or slack adjuster. An anti-compounding system is especially important in protecting the adjusting mechanism of automatic slack adjusters from damage caused by over torque that occurs during a compounded application of the brakes.

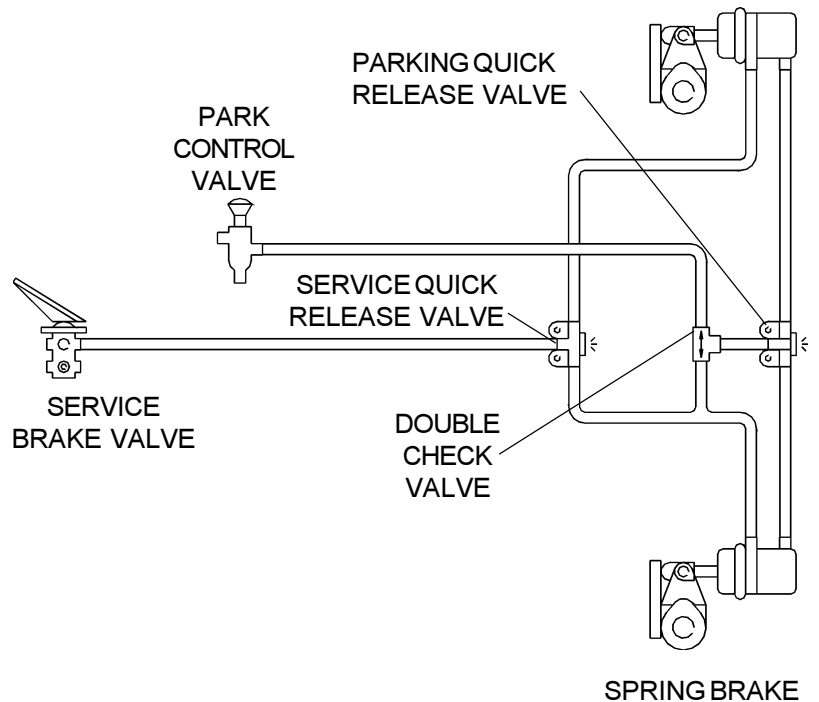

The anti-compounding system prevents the simultaneous application of both the air and spring brakes by directing application air to the spring brakes when both are applied at once. In the simple anti-compounding schematic shown here, the double check valve allows service application air to apply the service brakes AND move into the spring cavity if they are also applied (no air pressure and springs are also applying brakes).

The anti-compounding function of the double check valve is built into several air brake devices such as the R-8, R-14 and QR-1C. When these devices are used in the system, a separate double check valve for anti-compounding is not needed.

It is recommended that the service connection to the anti-compounding device (double check valve) come from a point between the service brake chamber and the first "upstream" service device (in this case a quick release valve). This will assure reliable cold weather operation

### QUICK RELEASE VALVE

The **QR-1C** is a dual function valve. The valve's primary function is to serve the emergency side of a spring brake actuator as a quick release valve. In addition, it functions as an anti-compound device. The double check valve prevents a service and emergency brake application from occurring simultaneously.



**QR-1C**

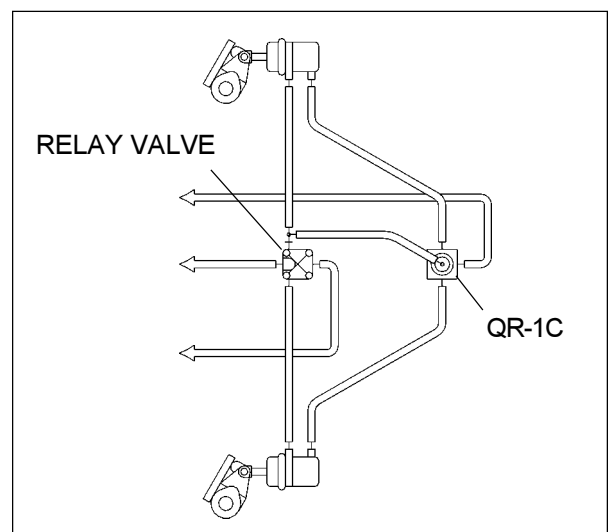
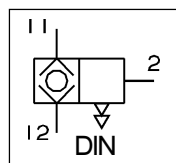

## RELAY VALVE

**Relay valves** are primarily used on long wheelbase vehicles to apply and release rear axle(s) service or parking brakes. They are air operated, graduating control valves of high capacity and fast response. Upon signal pressure from the service brake valve, they graduate, hold or release air pressure from the chambers to which they are connected. They are generally mounted close to the chambers they serve. Relay valves are available in both remote and reservoir mount designs and feature inlet/exhaust valve cartridge replacement without line removal.

The **R-8 and R-14 relay valves** both incorporate an integral double check valve with a balance port connection which provides both an anti-compounding or quick exhaust feature depending upon vehicle application. The anti-compound feature is used when these valves are used to control spring actuated parking features.

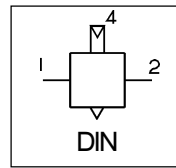

R-12  
RELAY VALVE



R-12  
DuraDrain™



R-6  
RELAY VALVE



R-8  
RELAY VALVE



R-14  
RELAY VALVE

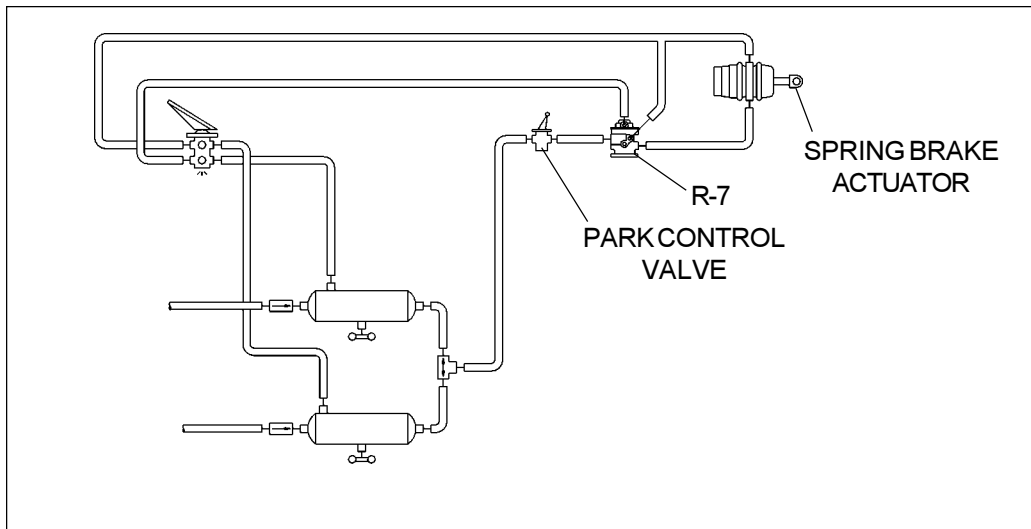
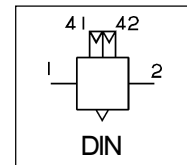

## R-7 MODULATING VALVE

The **R-7 Modulating Valve** is used in dual circuit brake systems and performs four functions; during normal operation, it limits hold-off pressure to the spring brakes, provides quick release of air pressure from the spring cavity of the spring brake actuator allowing a fast application of the spring brake actuators, modulates spring brake actuator application should a failure occur in the service brake system and prevents compounding of service and spring forces.



R-7

## SR-1 SPRING BRAKE VALVE

The **SR-1 spring brake valve** is used in FMVSS 121 dual circuit brake systems and serves two functions; during normal operation, it limits hold-off pressure to the spring brakes to 90 or 95 psi. Should a loss of pressure occur in the rear service brake service supply, it will provide a modulated spring brake application proportional to service braking pressure delivered to the front axle.



SR-1

## PUSH PULL CONTROL VALVES

**Push-Pull control valves** are most often mounted on the vehicle dash board and are used for a variety of control applications. The PP-1 and PP-2 are pressure sensitive, normally closed, on/off control valves which automatically return to the exhaust (button out) position when supply pressure is below the required minimum. They may be manually operated to either position when pressure is above the required minimum. Pressure settings and button configuration and lettering may vary, depending on application.

The **PP-1** is commonly used to control parking and emergency brakes. This valve is also used in conjunction with the TP-2 Tractor Protection valve in pre-121 single circuit tractor air systems.

The **PP-2** was primarily designed to control parking and emergency brakes. In addition to normal on-off control, the PP-2 features an anti-compounding port, which when used will prevent simultaneous application of both service and parking brakes.

Unlike most other push-pull control valves, the **PP-8** is nonautomatic, and will remain in the applied (button in) position regardless of delivery or supply pressure. The PP-8 is commonly used to control the tractor brakes only in the 121 dual system.

The **RD-3** is a manually operated on-off control valve. The valve is spring loaded and will remain in the exhaust (button out) position. Constant manual force is required to cause the valve to deliver air. The RD-3 is primarily used as an emergency brake release control valve.



PP-1



PP-2



PP-8



RD-3

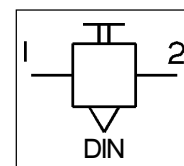
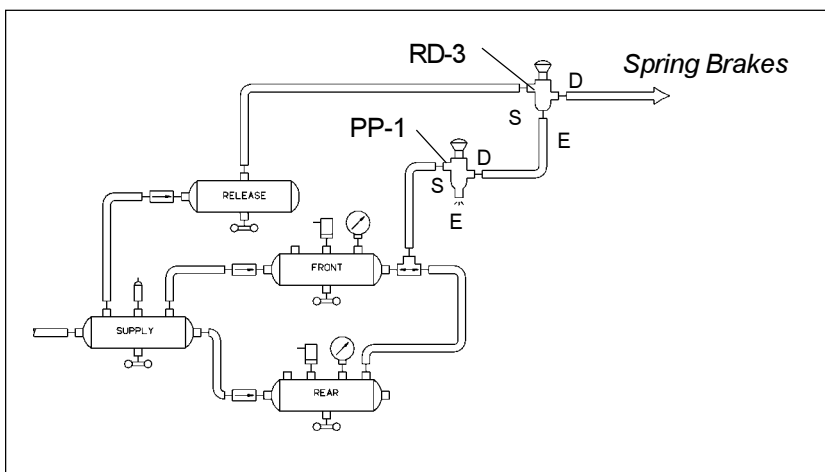

## PARK CONTROL VALVES

The **PP-DC park control double check valve** is a push-pull, manually operable on/off valve with an integral double check. It is dashboard mounted and provides in-cab control of truck or bus parking brakes. Manually pushing or pulling the button will release or apply the parking brakes. The integral double check valve allows the PP-DC to receive supply air pressure from either, or both, the front or rear axle service reservoirs.

The valve is pressure sensitive and automatically moves from the applied to the exhaust position if total system pressure (both front and rear axle reservoirs) drops below 20 to 30 psi.



**PP-DC**

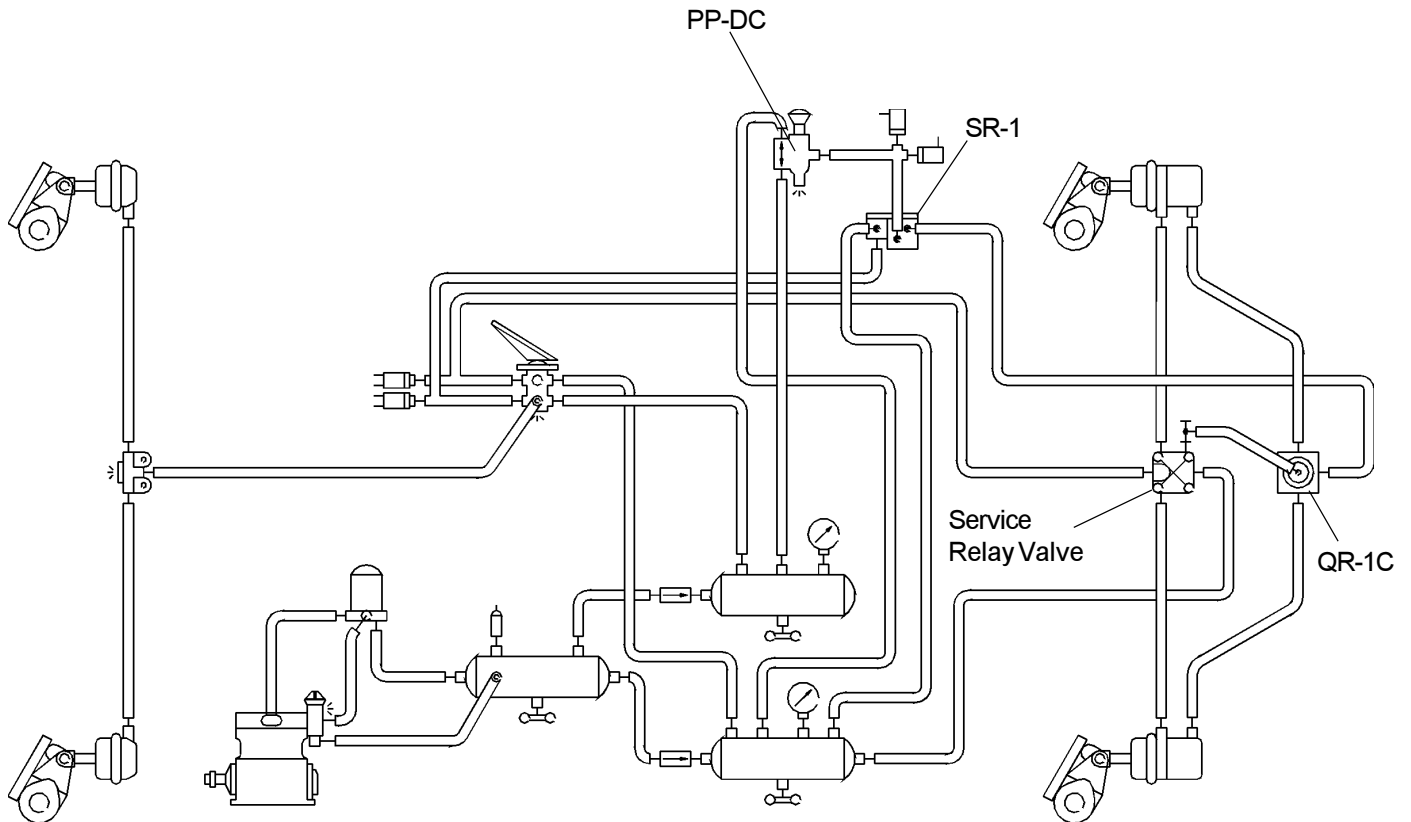



## LEVER OPERATED CONTROL VALVES

The **TW-2** and **TH-3** are identical in appearance and similar to the **TW-1**, **TW-3** and **TW-4** except that two control valves are housed in a single body. A single cammed control lever controls both of the internal valves, and depending upon the camming design, the valve will be designated either TW-2 or TH-3. The **TW-2** control valve has two lever positions while the **TH-3** has three lever positions.

The **TW-1**, **TW-3** and **TW-6** series control valves are manually operated, non-modulating control valves used in a wide variety of control functions. The most popular configurations are the TW-1 and TW-3 dash mounted, lever controlled valves, however the TW-6 provides basically the same function but is designed for cable control.

The **TW-4** is a manually operated momentary non-modulating control valve commonly used in conjunction with air starter systems.

A momentary push type control valve, the **TW-5** will deliver air pressure when the plunger is pushed in and exhaust delivered air when the plunger load is released. Typical application is Differential Lock-Out control.



TW-2 & TH-3



TW-1



TW-3



TW-6



TW-4



TW-5

The **TC-4 modulating control valve** is a cam operated, graduating type control valve. The valve is used to control the application and release of spring brake actuators, and is generally mounted on the dash within easy reach of the driver. The TC-4 incorporates a locking button which allows the handle to be locked into the "brakes applied" position. This device is most often found on school busses.

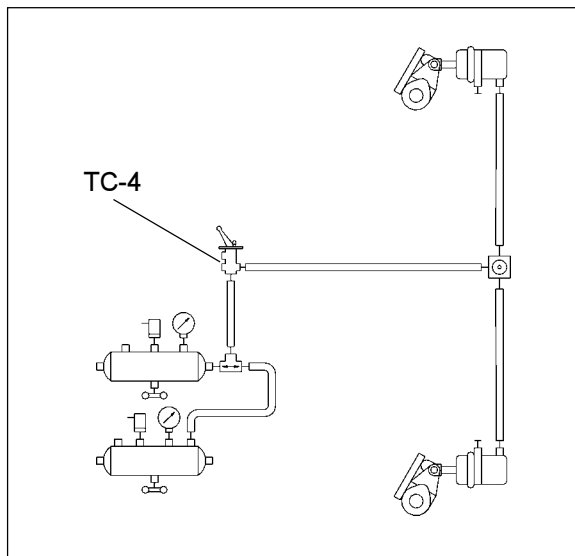

TC-4

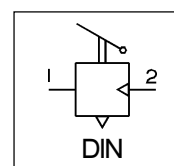

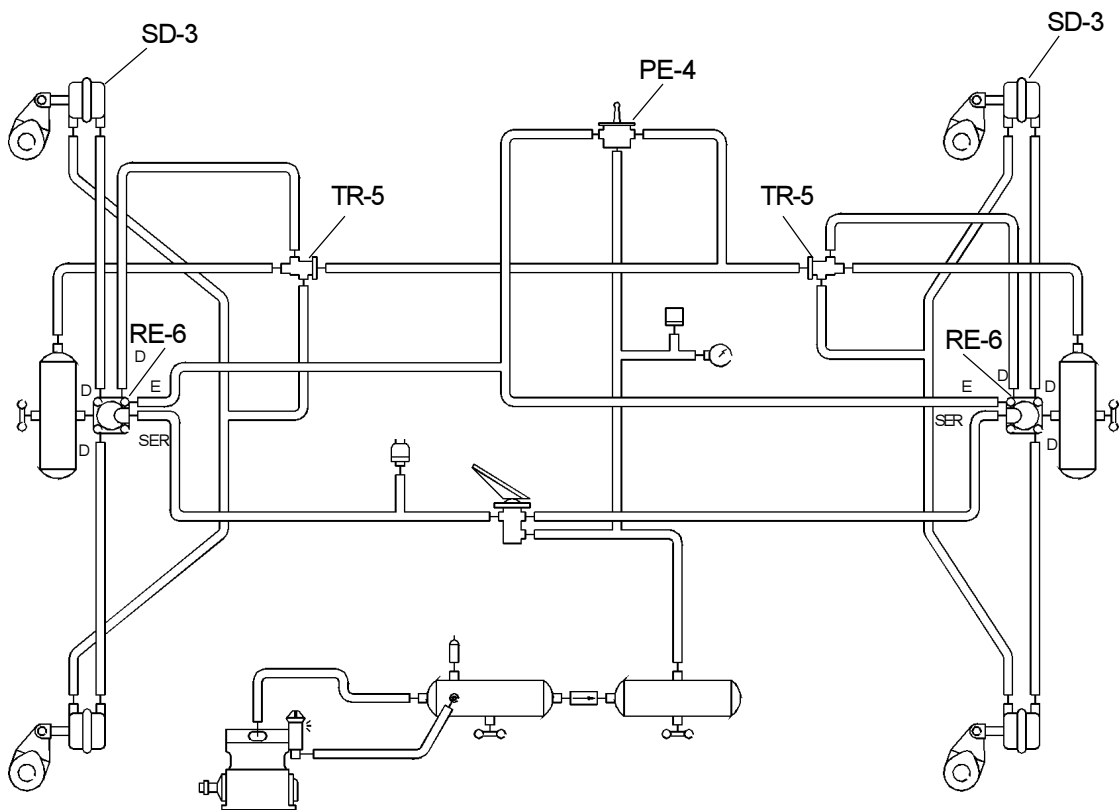

### LOCK LINE CONTROL VALVE

The **TR-5** is a specialized, pilot operated, non-automatic, ON-OFF control valve, designed primarily for use in OFF HIGHWAY parking and emergency brake systems. It is almost identical in appearance to the SV-1 control valve. Unlike the SV-1, the TR-5 reacts to control pressure from two different sources and does not have an exhaust.



**TR-5  
LOCK LINE CONTROL VALVE**

### PARK EMERGENCY CONTROL VALVE

The **PE-4 control valve** is most often used as the control for off highway emergency/park brake systems. It is essentially a variation of the TH-3 which incorporates two TW-1 type valves in a single body. A common air supply is provided for the two valves and a single, cammed lever is used which has three operating positions and "Z" shift pattern.



**PE-4**

### ROTO SAFETY ACTUATOR

The **SD-3 roto safety actuator** is basically a rotochamber with mechanical roller locking mechanism similar to that of the DD-3 actuator. The SD-3 is generally used on off-highway vehicles, and is piped in various ways to provide service, emergency, and parking brake functions. It is available in type 36 and 50 sizes.



**SD-3  
SINGLE DIAPHRAGM  
ROTO SAFETY ACTUATOR**

## SYNCHRO VALVE

The **SV-1 synchro valve** is a pilot operated, non-graduating control valve. When used in non-automatic applications it controls air from a remote supply which is different than control. The SV-1 can also be used in automatic applications where it supply and control are connected and the valve will open, close and exhaust automatically as common control and supply pressure rises or falls. The valve is available in various opening and closing pressures and can be used to delay or sequence the action of other pneumatic devices.

SV-1

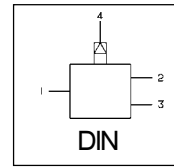

## SHUT OFF VALVE

The **SS-1 shut-off valve** is an air operated on-off valve and is non-exhausting. The valve may be remotely mounted and opened and closed using air pressure. The SS-1 is similar in operation to an air starter valve (AS-1, 2,3) except that it has a lesser capacity.



SS-1

## CONTROL VALVES

The **PP-5 push pull control valve** is a pressure sensitive, on - off control valve. It is used in conjunction with vehicle torque converter systems, engine speed control systems and some parking brake systems. In addition to automatic exhaust and manual control, the PP-5 employs a pilot air release feature (interlock) which will allow the valve to be exhausted by applying a low pressure signal from another control valve to the PP-5 control port.



PP-5

## AUTOBRAKE™

The Bendix **AutoBrake**, installed on school busses, applies an automatic 44 psi brake application when; the door is open, the flashing red lights are on and the stop sign is extended. This virtually eliminates the possibility of the bus rolling forward or backward, without having to use the parking brake.



SBI-1  
AutoBrake™

# AUXILIARY SYSTEMS

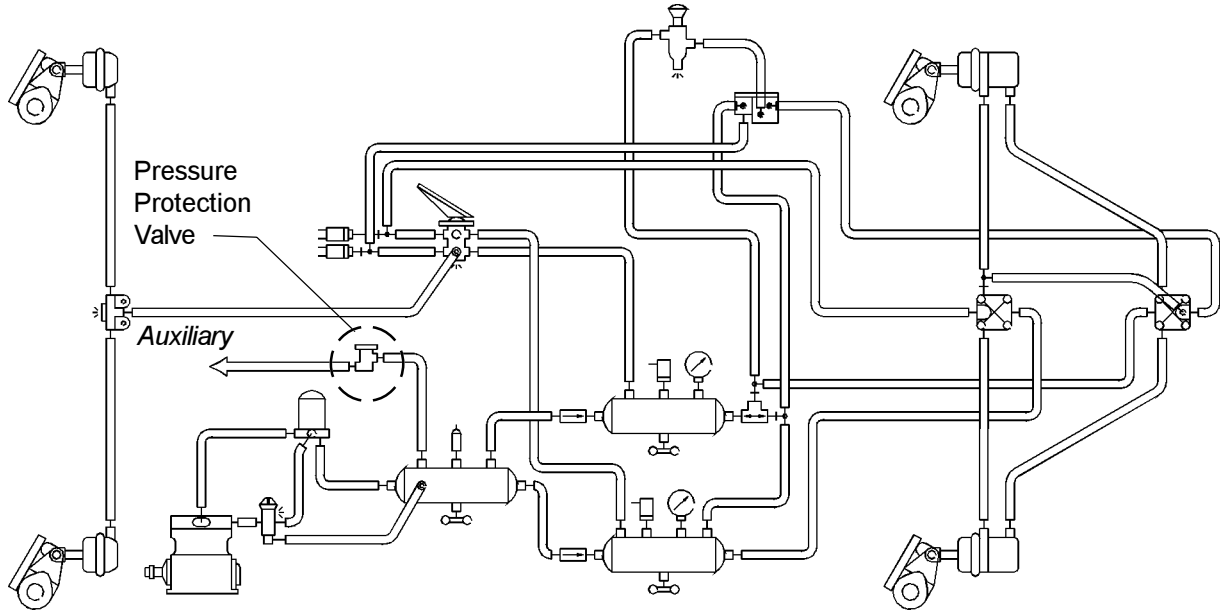

## PRESSURE PROTECTION VALVE

The **pressure protection valve** is normally closed pressure sensitive control valve. These valves can be used in many different applications but are typically used to protect or isolate one reservoir from another, by closing automatically at a preset pressure. The valve is also commonly used to delay the filling of auxiliary reservoirs until a preset pressure is achieved in the primary or braking reservoirs. Pressure protection valves allow air to be "shared" between two reservoirs above the closing setting of the valve. The sharing ceases when pressure drops below the closing pressure of the valve and the reservoirs are then isolated from each other.

The **PR-2** is externally adjustable, while the **PR-4** has a fixed setting. Both valves are available in various factory preset pressure settings.



PR-2



PR-4

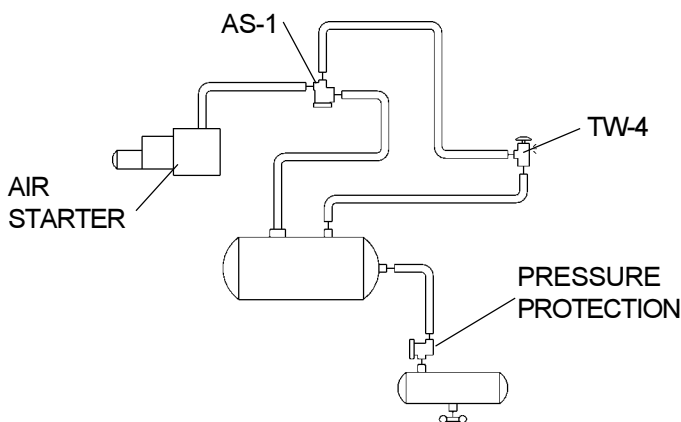
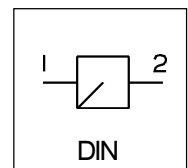

AS-1  
AS-2



AS-3

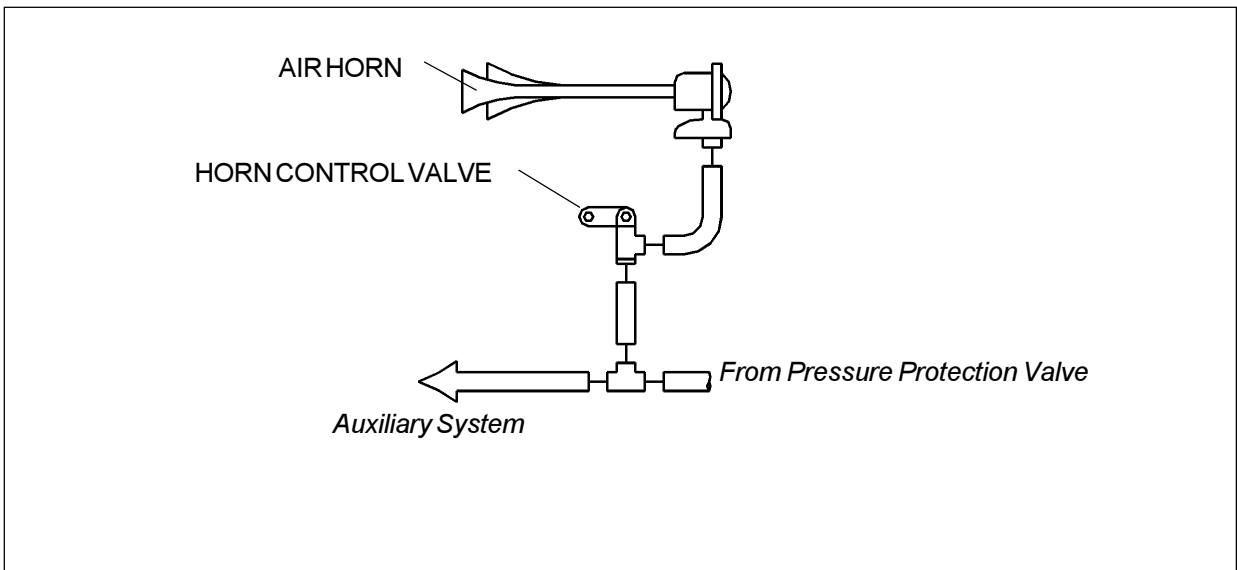

### AIR HORNS

The **Zeph-Air horn** is an air operated, two trumpet, dual tone warning device of low air consumption. The air horn is controlled by a horn valve such as the HV-3.



PH-1

### HV-3 HORN CONTROL VALVES

Horn valves are available in various styles; foot operated, hand operated and lanyard (lever) operated. All models are momentary, designed to return to the off position when application force is removed.



Lanyard Operated



Hand Operated

### HORN CONTROL VALVES

## FAN CLUTCH

The **Fan Clutch** is an air-operated, normally engaged, on-off clutch that controls the engine cooling fan. The Fan Clutch is thermally-pneumatically controlled by a valve which senses engine coolant temperature and maintains engine temperature by engaging or disengaging the cooling fan. Utilizing a Fan Clutch provides several advantages; conserves fuel, better engine efficiency, faster warm-ups, and a quieter vehicle.

The **FD-L** and **FD-3** are designed to be fail safe. Both models feature spring engagement and air disengagement.

Many different models which accommodate most later model vehicle/engine combinations are available in kit form and contain all the necessary parts for installation.

Control kits which contain necessary valving are available for various installations including shutter equipped and air-conditioning equipped vehicles.



FD-L



FD-3

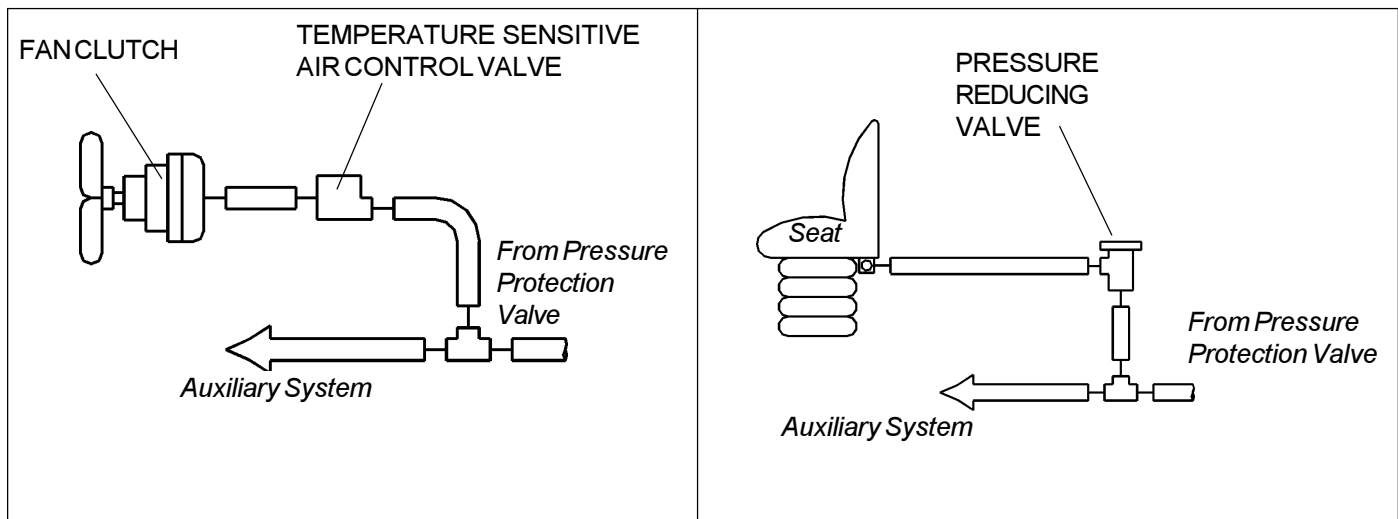

## PRESSURE REDUCING VALVE

The **pressure reducing valve** is used in various applications where a constant set air pressure lower than supply pressure is required. A typical application is an air operated accessory that requires less than system pressure for operation.

The **RV-1** is available in a wide range of pressure settings and can be manually adjusted. The **RV-3** is available with factory preset pressure settings only and cannot be manually adjusted.



RV-1



RV-3

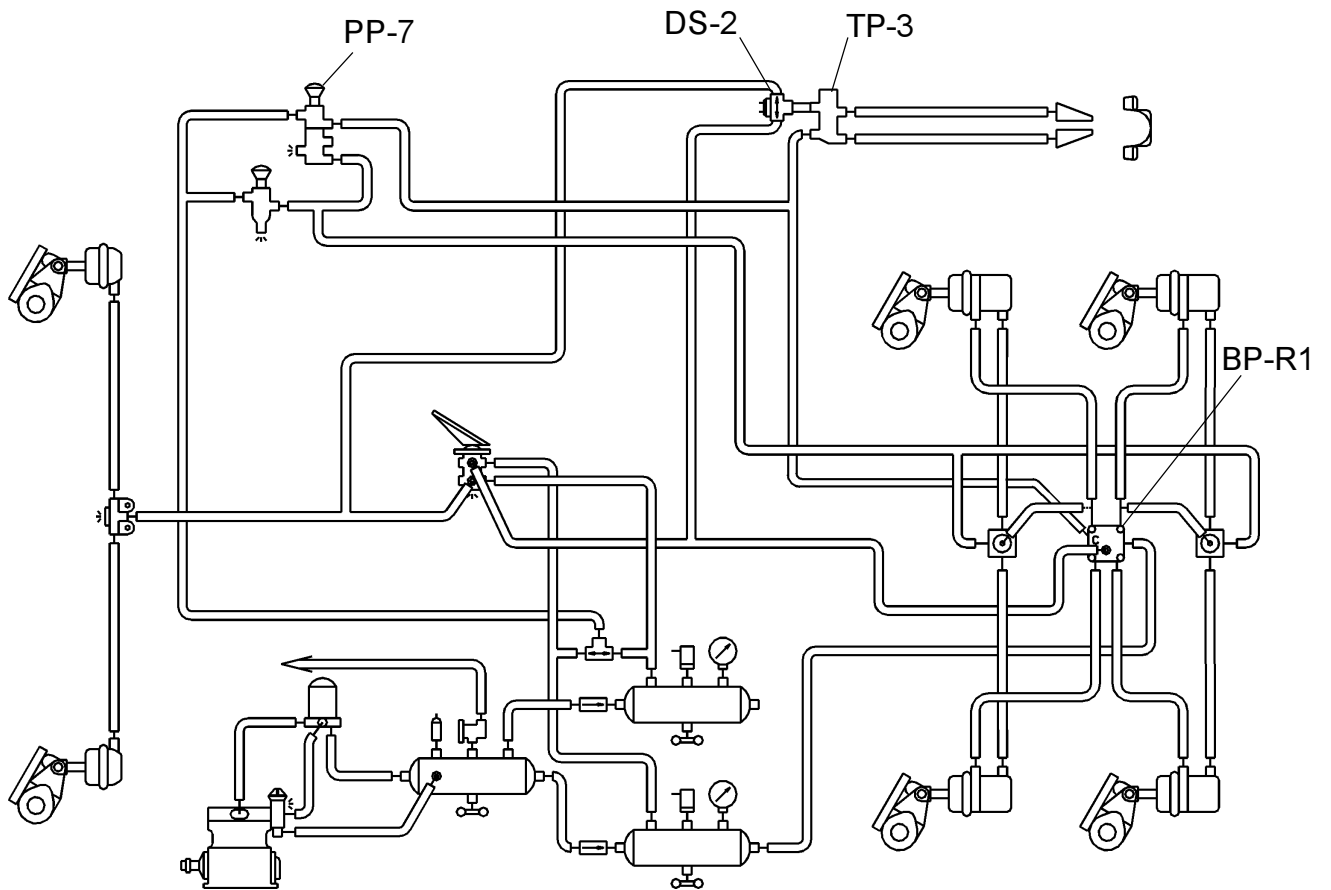
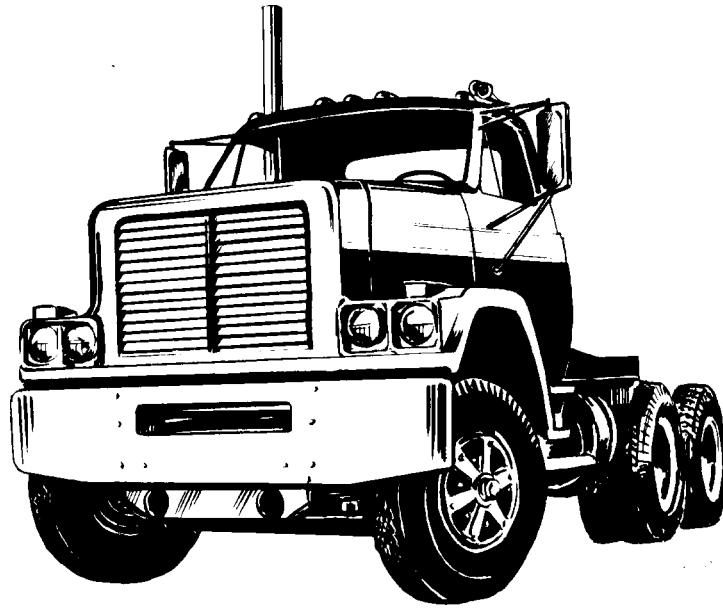

## CONTROL VALVE

The **PP-3 control valve** is primarily used to control the TP-3 Tractor Protection valve in Pre-121 tractor systems. It features a tripper piston which prevents manual override of the emergency application of trailer brakes.

PP-3



---

## DOUBLE CHECK AND STOP LIGHT SWITCH

The **double check valve and stop light switch** performs the function of both a stop lamp switch and a double check valve. It accepts a signal or supply pressure from two sources, and delivers into a common outlet.

The double check portion of the device typically directs either front or rear axle service braking pressure, from the dual circuit foot brake valve, to and through the Tractor Protection Valve. Since both front and rear braking circuits are piped into the device, pressure from either source will operate the stop lamp switch, lighting the stop lamps.

The **DS-1** was used primarily in pre-121 systems, and is serviceable. The **DS-2** is designed to meet FMVSS 121 requirements and is non-serviceable.



DS-2

---

## TRAILER SUPPLY VALVE (TRACTOR PROTECTION CONTROL)

The **PP-7 push-pull control valve** is a pressure sensitive, on/off control valve which will automatically return to the exhaust (button out) position when supply pressure is below the required minimum. It may be manually operated to either position when pressure is above the required minimum. Button configuration and lettering may vary depending on application. The automatic exhaust pressure is 40 psi.

The PP-7 is used to control the tractor protection system and is generally identified as the trailer air supply valve. The valve employs an air operated interlock in the lower body which will apply the trailer brakes when the tractor spring brakes are applied. The interlock insures that the tractor spring brake can not be applied without the trailer spring brakes also being applied. Normally this action will not affect the position of the PP-7 valve button. The interlock of tractor and trailer parking is a requirement of FMVSS 121.



PP-7

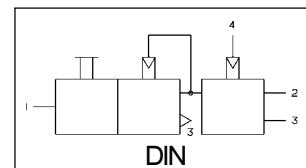



## TRACTOR PROTECTION

The primary function of the **TP-3 tractor protection valve** is to protect the tractor air brake system under trailer break-away conditions and/or conditions where severe air leakage develops in the tractor or trailer. In addition, in everyday use, the valve is used to shut off the trailer service and supply lines before disconnecting the tractor from the trailer. The valve is usually mounted at the rear of the tractor cab and is controlled by a dash mounted valve .

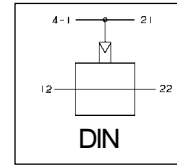

**TP-3**

The **TP-3DC tractor protection valve** integrates the functions of the TP-3 and one double check valve. The double check valve serves the same function as the shuttle portion of the DS-2. A stop light switch port is provided and is connected to the delivery of the double check. It also has an integral single check valve that prevents trapping of air in the trailer service line and thus prevents brake compounding and minimizes roll away conditions.



**TP-3DC**

The **TP-4 and TP-5 tractor protection valves** are designed to incorporate several pneumatic control functions within a common housing, thereby eliminating considerable interconnection piping.

The TP-4 and TP-5 were formerly known as the VM-1 and VM-2 control manifolds, respectively.

They are a combination of two double check valves and a tractor protection valve. With these valves, either of the two service brake circuits of the dual air system on the vehicle can be used to apply the trailer brakes. In addition, when used in conjunction with a control valve, it opens and closes the trailer service and supply lines in the same manner as a tractor protection valve. The valves also incorporate porting for the installation of the service stop lamp switch.



**TP-4**

The TP-4 is a proprietary valve used exclusively on Ford "L" model tractors and incorporates porting for a front axle limiting control (on pre-121 vehicles).

In addition the feature named, the TP-5 also incorporates a quick release valve for the Trailer Service Line.



**TP-5**

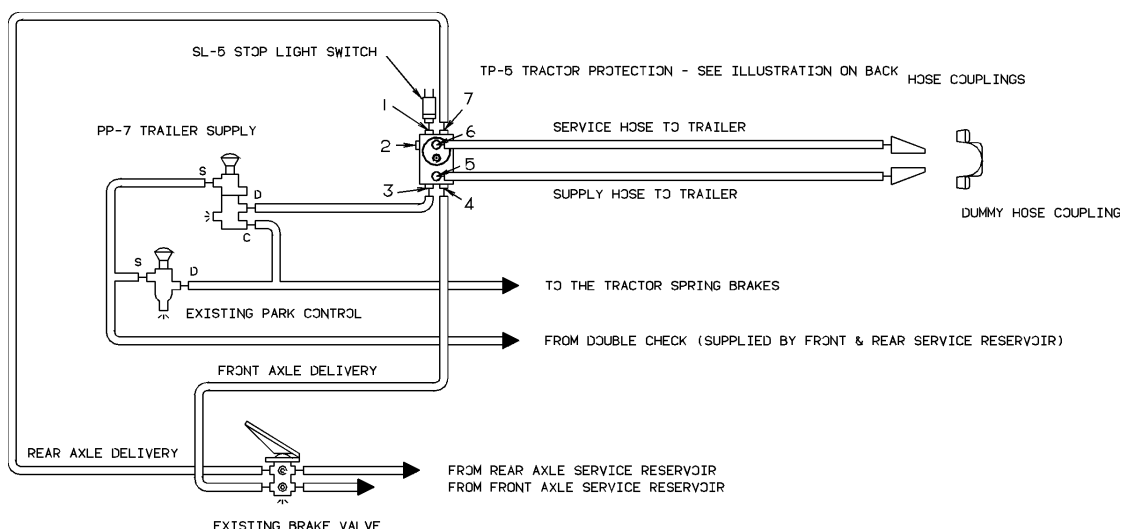

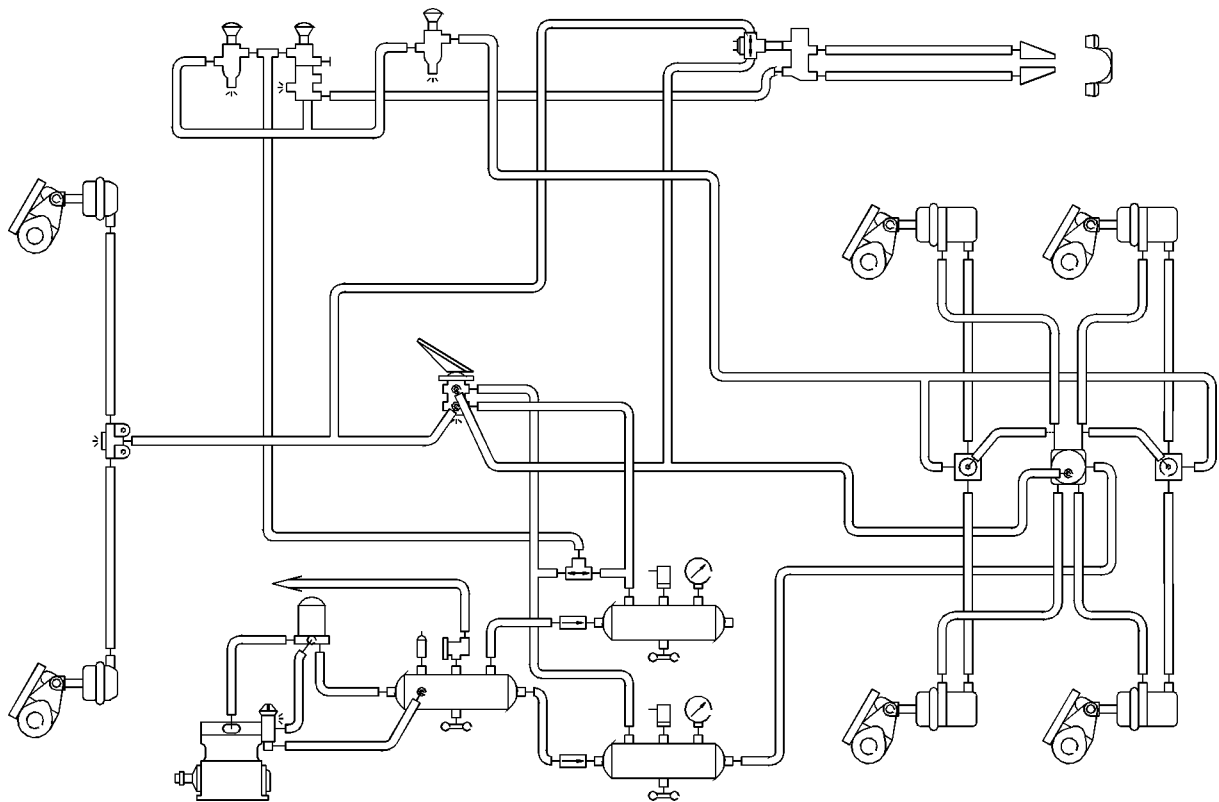

## CONTROL MODULE

The MV-1 modutrol assembly is used exclusively on Ford "CL" vehicles. It is an integrated air control module designed for vehicle dash mounting. The assembly contains three push-pull type valves and two optional lever-type valves. The optional lever-type valves may be used to control any on/off type auxiliary devices; such as a sliding fifth wheel, inter-axle lockout, etc.



MV-1

## CONTROL MODULE

The **MV-2 and MV-3 control modules** are an integrated control assembly designed for control panel mounting in a truck-tractor. These nonmetallic assemblies consist of two push-pull valves and a dual circuit supply valve. They meet FMVSS 121 requirements for trailer air supply and parking brake control while providing a feature that permits the tractor parking brakes to be applied while air is supplied by the trailer. The MV-3 supersedes the MV-2 valve.

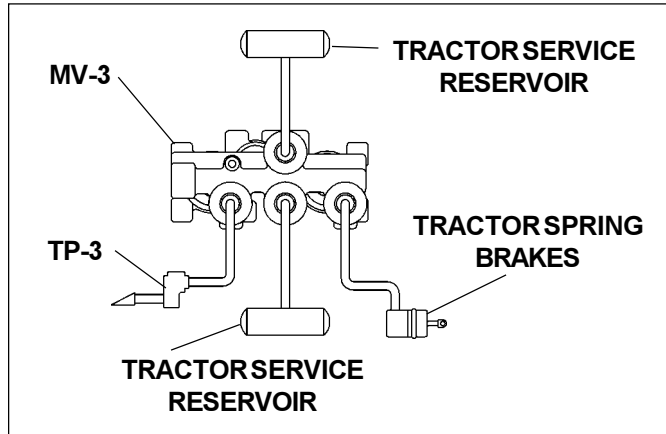

MV-3



MV-2

## TRAILER CONTROL (HAND CONTROL VALVE)

**Trailer control (TC) valves** are hand operated, graduating control valves. The most common use of the trailer control valve is for independent control of trailer service brakes, however, the valve can be used for any application where graduated application pressure is required.

These valves employ a cam, cam follower, and a graduation spring to control air delivery pressure and are available in various body, handle, and clamp configurations. Some models are available with self-returning handles. Trailer control valves are most often used to snub the trailer brakes when descending grades or on slippery road conditions. They are also often used to hold the vehicle while the vehicle's clutch and accelerator are coordinated. The trailer control valve should never be used for parking.

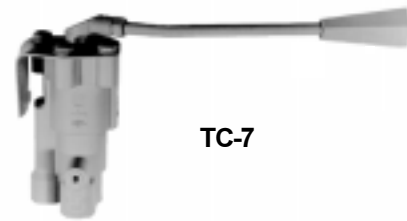

TC-7



TC-2



TC-6

## HOSE COUPLINGS

The **HC-1 and HC-2 Tru-Cupl hose couplings** are quick disconnect devices primarily used as tractor-trailer hose connections. The Tru-Cupl, HC-2 service and emergency couplings are unilateral and will not mate with each, but will mate with all HC-1 couplings.

**Dummy couplings** are mounted on the tractor to provide a hanger for hose couplings when a tractor is not coupled to a trailer.



HC-1 / HC-2

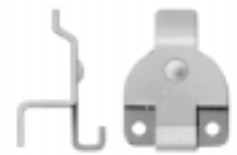

DUMMY COUPLINGS

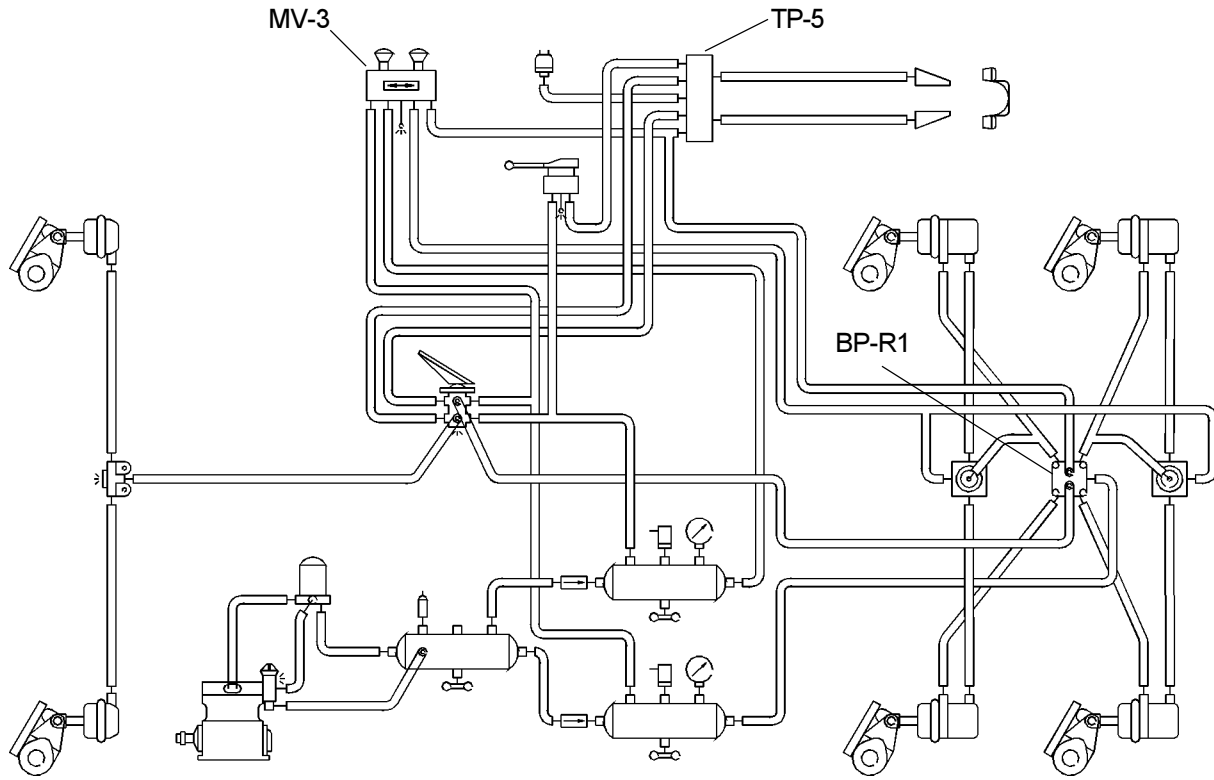

### BRAKE PROPORTIONING RELAY VALVE

The **BP-R1 bobtail proportioning relay valve** is a combination of two valves in a single housing. The lower portion contains a "standard" service brake relay valve, which functions as a relay station to speed up brake application and release. The upper portion houses a brake proportioning valve which reduces normal service brake application pressure when the tractor is not towing a trailer (bobtail operation). The control port on the BP-R1 is connected to the Trailer Supply valve delivery and signals bobtail operation.



**BP-R1**

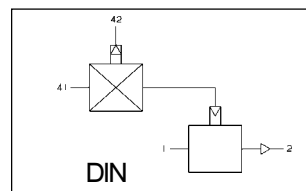

## BOBTAIL RATIO VALVE

The **LQ-5 bobtail ratio valve** is used on the front (steering) axle of tractor air brake systems to reduce brake application pressure during normal tractor-trailer operation. During bobtail mode, tractor braking performance is improved because the LQ-5 delivers full brake pressure to the steering axle.

The LQ-5 is designed for tractor systems only, and it replaces the existing front axle limiting valve.

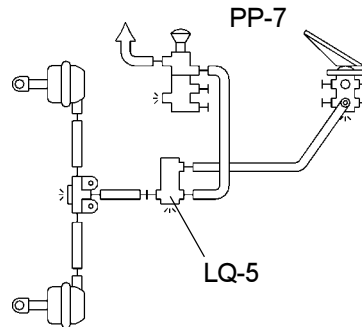

LQ-5

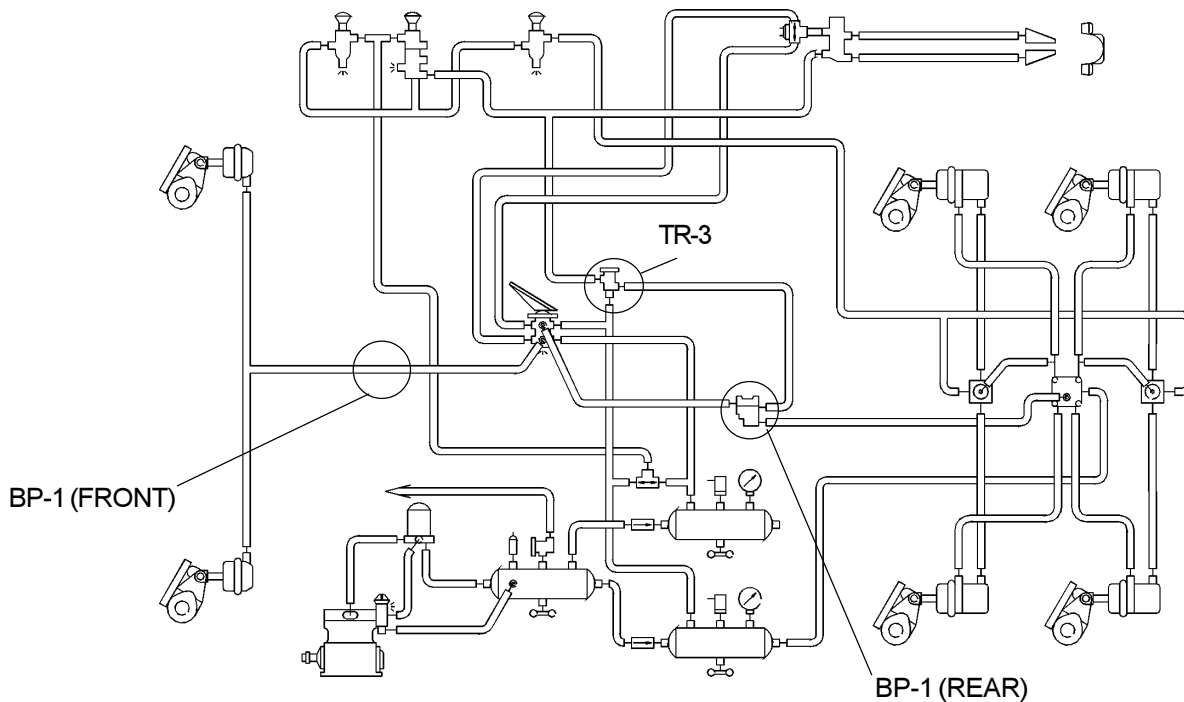
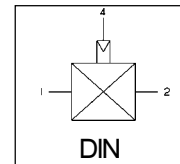

## AIR BRAKE PROPORTIONING VALVE

The **BP-1 brake proportioning valves** are incorporated into the air systems to improve the controllability and reduce the stopping distance of bobtail operated tractors during braking. The TR-3 senses the lack of trailer supply line pressure during bobtail operation, and controls the BP-1 FRONT and REAR valves. The BP-1 FRONT reduces application pressure to the front brakes during tractor trailer operation and returns to full application pressure during bobtail operation. The BP-1 REAR delivers full pressure during tractor trailer operation and reduces application pressure during bobtail operation. Treadle application force, during bobtail operation, resembles treadle application force, during tractor operation with a loaded trailer.

Both the BP-1 FRONT and REAR valve are identical in appearance to the LQ-5. A metal tag identifies the BP-1 valves.



BP-1

## TRACTOR ELECTRONICS

### ELECTRONIC THROTTLES

The **ET-2** is installed on vehicles with electronically controlled, fuel management system on newer diesel engines. The electronic throttle replaces the mechanical accelerator pedal and linkage found on conventional diesel engine, fuel management systems. It provides graduated throttle control by communicating with the Electronic Control Module (ECM) controlling the engine.



**ET-2**



**ET-S**



**ET-S2**

---

### INDICATION AND SHUTDOWN MODULE

The **IS-1 & IS-2 indication and shutdown modules** monitor and display vehicle operations such as turn signal indicators, high beam indicators, low oil pressure, low air pressure, coolant level and coolant temperature. All three models activate a warning light and/or buzzer when any of the monitored functions is outside acceptable tolerances for the vehicle. If a particular condition worsens the IS-1 will shut down the engine.

In addition to the standard functions, the modules may include indicator lights for optional features such as; transmission temperature, fifth wheel lock, utility lock, utility light, sludge ejector, alternator no charge, engine heater, mirror heater, sander, axle temperature, parking brake, cruise control and PTO.

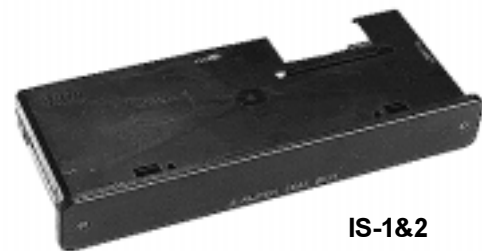

**IS-1&2**

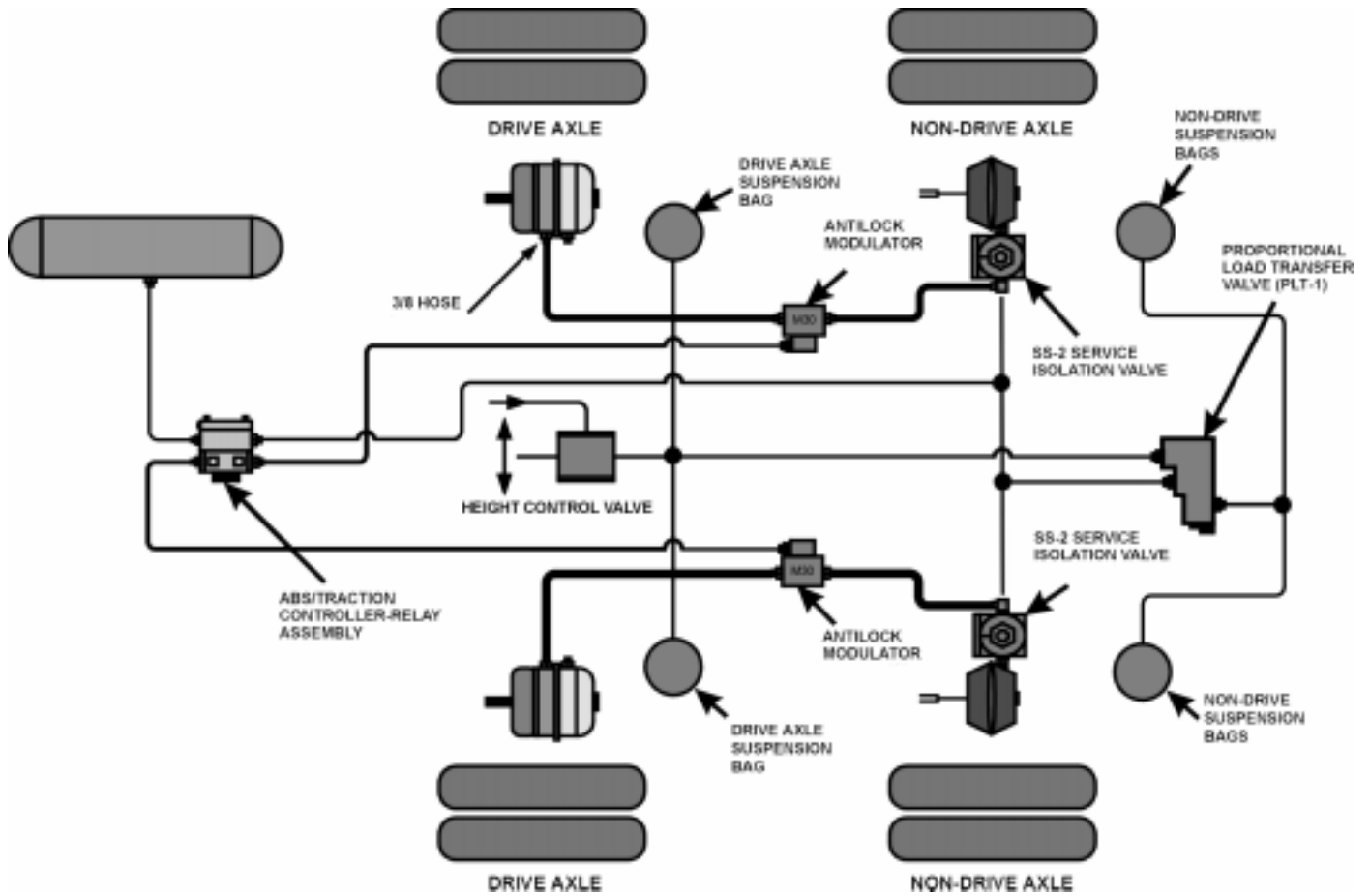

### VALUETRAC™

Used in conjunction with the Bendix ABS/Traction control system, Valuetrac™ provides traction performance similar to a 6X4 vehicle in low traction conditions up to 25 m.p.h. and is especially useful in low traction pull away situations. Like the traction control system, Valuetrac is a completely automatic system requiring no driver inputs to activate or deactivate. The Valuetrac system is typically comprised of a single Proportional Load Transfer (PLT-1) valve and two SS-2 Service Isolation Valves. Traction control is an extension of antilock. Just as antilock helps vehicle control and stability during braking, traction control helps during vehicle acceleration. Wheel speed sensors not only detect rapid decreases in wheel speed for antilock but also detect unreasonably high increases for traction control. Using the system speed sensors, a spinning wheel is instantly detected and compared with the other wheels on the vehicle, both front and rear.



**SS-2 Service Isolation Valve**



**PLT-1 Proportional Load Transfer Valve**

## ANTILOCK SYSTEMS

Bendix **Antilock systems and components** are designed to provide improved vehicle stability by reducing wheel lock during aggressive braking. While all Bendix Antilock systems provide this basic benefit, there are several different systems and components offered. Each is designed to meet the specific needs of the customer. System components are available for tractors, trucks, buses and trailers. Each modulator controller assembly model represents a different method of vehicle control and, in most cases, a different level of system performance.

All Bendix Antilock controllers feature digital electronics with self test and diagnostic circuitry that continuously monitors operation of the entire antilock system including wiring continuity. The condition of specific antilock components is provided to maintenance personnel by a series of labeled, Light Emitting Diodes (LED's) displayed through a diagnostic window in the controller housing. No special tools or equipment are needed to read or interpret the diagnostics window. It should be noted that the diagnostics display is separate from the antilock condition lamp on the dash. Feature conditions are stored in the controller's "memory" and are not cleared by loss of power to the unit. Passing an ordinary magnet over the RESET point in the diagnostic window is all that is necessary to clear the diagnostic display after repairs have been made.

---

### FULL VEHICLE WHEEL CONTROL ANTILOCK CONTROLLER RELAY ASSEMBLIES

The **Bendix controller relay**, antilock assemblies are designed for use on tractors, trucks, and buses. They are comprised of a service relay valve, which has a body modified to allow mounting, and an antilock controller. These modified relays contain no electronics and all antilock functions are contained in the controller.

---

### ANTILOCK TRACTION ASSEMBLY

The **Bendix antilock traction assemblies**, are an extension of the controller relay assemblies. In addition to performing the full vehicle, wheel control antilock function they also provide a traction control feature. To accomplish this, a traction control solenoid is incorporated in the service relay. When a drive wheel begins to spin, at speeds lower than 25mph, due to loss of traction between the tire and the road surface, the traction control feature attempts to compensate by lowering engine torque and/or transferring drive to a non-spinning wheel. The controller gently applies the brakes on the spinning wheel, using the modulators and the traction solenoid, thus transferring torque to the non-spinning wheel through the vehicle differential.

### Sentinel 6M Antilock-Traction System & Components

The Sentinel 6M is a wheel control antilock-traction system intended for use on 6x2 and 6x4 tractors, trucks and buses. Designed to minimize the potential of brake lock up on all wheels during aggressive braking, the Sentinel 6M based antilock system provides the vehicle with a high degree of stability and steerability during braking. In most cases, vehicle stopping distance is also reduced. The antilock portion of the Sentinel 6M system minimizes wheel skid at all wheels on the vehicle, optimum steering control and stopping distance is obtained.

Traction control, an optional feature of the Sentinel 6M system, helps improve vehicle traction during acceleration in adverse road conditions.

---

### FULL VEHICLE, AXLE CONTROL ANTILOCK MODULATOR CONTROLLER

The **modulator controller** antilock assembly is designed for use on tractors, trucks and buses. It is comprised of a single integral modulator and the electronic controller. The controller is a full vehicle, axle control antilock system capable of controlling the steering axle and either a single or tandem rear axle. The modulator is used to control the rear axle and a separate modulator controls the front axle. Four speed sensors provide vehicle speed information. The assembly either mounts to the vehicle frame or directly to a reservoir and replaces the rear axle service relay valve.



## TRAILER ANTILOCK MODULATOR CONTROLLER

The **modulator controller** antilock assembly is an axle or tandem control antilock system for trailers. An electronic controller and an modulator comprise the modulator controller assembly. The modulator controller has a single, integral modulator and receives input from two speed sensors. The assembly either mounts to the vehicle frame or directly to a reservoir and replaces the service relay valve.

---

## WHEEL SPEED SENSOR













The **wheel speed sensor** is an electromagnetic device used to obtain vehicle speed information for the antilock controller. The is mounted on the axle and works in conjunction with an exciter or tone wheel mounted in the wheel hub. When the wheel rotates, the exciter with its notched surface rotates across the face of the which generates a simple AC signal. The wheel speed sensor is connected to the antilock controller which then analyzes the signal and issues antilock commands accordingly.



## ANTILOCK MODULATOR ASSEMBLY

The **antilock system modulators** are high capacity, on/off air valves that incorporate a pair of electrical solenoids for control. The solenoids provide the electro-pneumatic interface or link between the antilock controller and the air brake system.



| MODEL<br>(SERVICE DATA SHEET)                            | PHOTO   | VEHICLE CONTROL METHOD  | NO. OF SPEED SENSORS<br>(SD-13-4754) | NO. OF MODULATORS<br>(SD-13-4733) | RELAY FUNCTION                  |
|--|---|---|--------------------------------------|-----------------------------------|---------------------------------|
| <b>MC-12</b><br>(SD-13-4762)                             |    | Trailer   | 2                                    | 1                                 | M-12<br>(SD-13-4722)            |
| <b>MC-30T</b><br>(SD-13-4834)                            |    | Trailer   | 2 / 4                                | 1 / 2                             | M-30T                           |
| <b>MC-14</b><br>(SD-13-4784)                             |    | Steering & Rear Axle or Tandem (2 Channel)  | 4                                    | 1                                 | M-12<br>(SD-13-4722)            |
| <b>CR-15</b><br>(SD-13-4795)                             |    | Full Vehicle Wheel Control Antilock (4 Channel)   | 4                                    | 4                                 | AR-1<br>(SD-13-4795)            |
| <b>CR-16</b><br>(SD-13-4795)                             |    | Full Vehicle Wheel Control Antilock & Bobtail Brake Proportioning (4 Channel)                       | 4                                    | 4                                 | AR-2<br>Bobtail<br>(SD-13-4796) |
| <b>CR-17</b><br>(SD-13-4787) EC-16<br>(SD-13-4788) EC-17 |   | Full Vehicle Wheel Control Antilock (4 Channel)   | 4 / 6                                | 4                                 | AR-1<br>(SD-13-4795)            |
| <b>CR-18</b><br>(SD-13-4787) EC-16<br>(SD-13-4788) EC-17 |  | Full Vehicle Wheel Control Antilock & Bobtail Brake Proportioning (4 Channel)                       | 4 / 6                                | 4                                 | AR-2<br>Bobtail<br>(SD-13-4796) |
| <b>AT-1</b><br>(SD-13-4787) EC-16<br>(SD-13-4788) EC-17  |  | Full Vehicle Wheel Control Antilock with Traction Control (4 Channel)                               | 4 / 6                                | 4                                 | ATR-1                           |
| <b>AT-2</b><br>(SD-13-4787) EC-16<br>(SD-13-4788) EC-17  |  | Full Vehicle Wheel Control Antilock with Traction Control & Bobtail Brake Proportioning (4 Channel) | 4 / 6                                | 4                                 | ATR-2<br>Bobtail                |
| <b>EC-15</b><br>(SD-13-4795)                             |  | Remote Mount Full Vehicle Wheel Control Antilock (4 Channel)  | 4                                    | 4                                 | R-12 or<br>BPR-1                |
| <b>EC-16 ABS</b><br>(SD-13-4787)                         |  | Remote Mount Full Vehicle Wheel Control Antilock (4 Channel)  | 4 / 6                                | 4                                 | R-12 or<br>BPR-1                |
| <b>EC-16 ABS/TC</b><br>(SD-13-4787)                      |  | Remote Mount Full Vehicle Wheel Control Antilock with Traction Control (4 Channel)                  | 4 / 6                                | 4                                 | ATR-1 or<br>ATR-2<br>Bobtail    |

| <b>MODEL<br/>(SERVICEDATA<br/>SHEET)</b> | <b>PHOTO</b>  | <b>VEHICLE CONTROL METHOD</b>  | <b>NO. OF SPEED<br/>SENSORS<br/>(SD-13-4754)</b> | <b>NO. OF<br/>MODULATORS<br/>(SD-13-4733)</b> | <b>RELAY FUNCTION</b>           |
|--|---|--|--|---|---------------------------------|
| <b>EC-17 ABS</b><br>(SD-13-4788)         |    | Remote Mount Full Vehicle<br>Wheel Control Antilock<br>(4 Channel)   | 4 / 6  | 4   | R-12 or<br>BPR-1<br>Bobtail     |
| <b>EC-17 ABS / ATC</b><br>(SD-13-4788)   |    | Remote Mount Full Vehicle<br>Wheel Control Antilock with<br>Traction Control (4 Channel)                     | 4 / 6  | 4   | ATR-1 or<br>ATR-2<br>Bobtail    |
| <b>EC-30 ABS</b><br>(SD-13-4815)         |    | Remote Mount Full Vehicle<br>Wheel Control Antilock<br>(4 Channel)   | 4 / 6  | 4   | R-12 or<br>BPR-1<br>Bobtail     |
| <b>EC-30 ABS / ATC</b><br>(SD-13-4815)   |    | Remote Mount Full Vehicle<br>Wheel Control Antilock with<br>Traction Control (4 Channel)                     | 4 / 6  | 4   | ATR-1 or<br>ATR-2<br>Bobtail    |
| <b>CR-30</b><br>(SD-13-4815)             |    | Full Vehicle Control Antilock<br>(4 Channel)   | 4 / 6  | 4   | AR-1<br>(SD-13-4795)            |
| <b>CR-30 BP</b><br>(SD-13-4815)          |   | Full Vehicle Wheel Control<br>Antilock with Bobtail Brake<br>Proportioning (4 Channel)                       | 4 / 6  | 4   | AR-2<br>Bobtail<br>(SD-13-4796) |
| <b>AT-30</b><br>(SD-13-4815)             |  | Full Vehicle Wheel Control<br>Antilock with Traction<br>Control (4 Channel)                                  | 4 / 6  | 4   | ATR-1                           |
| <b>AT-30 BP</b><br>(SD-13-4815)          |  | Full Vehicle Wheel Control<br>Antilock with Traction Control &<br>Bobtail Brake Proportioning<br>(4 Channel) | 4 / 6  | 4   | ATR-2<br>Bobtail                |

# TRAILER

## TRAILER SYSTEM

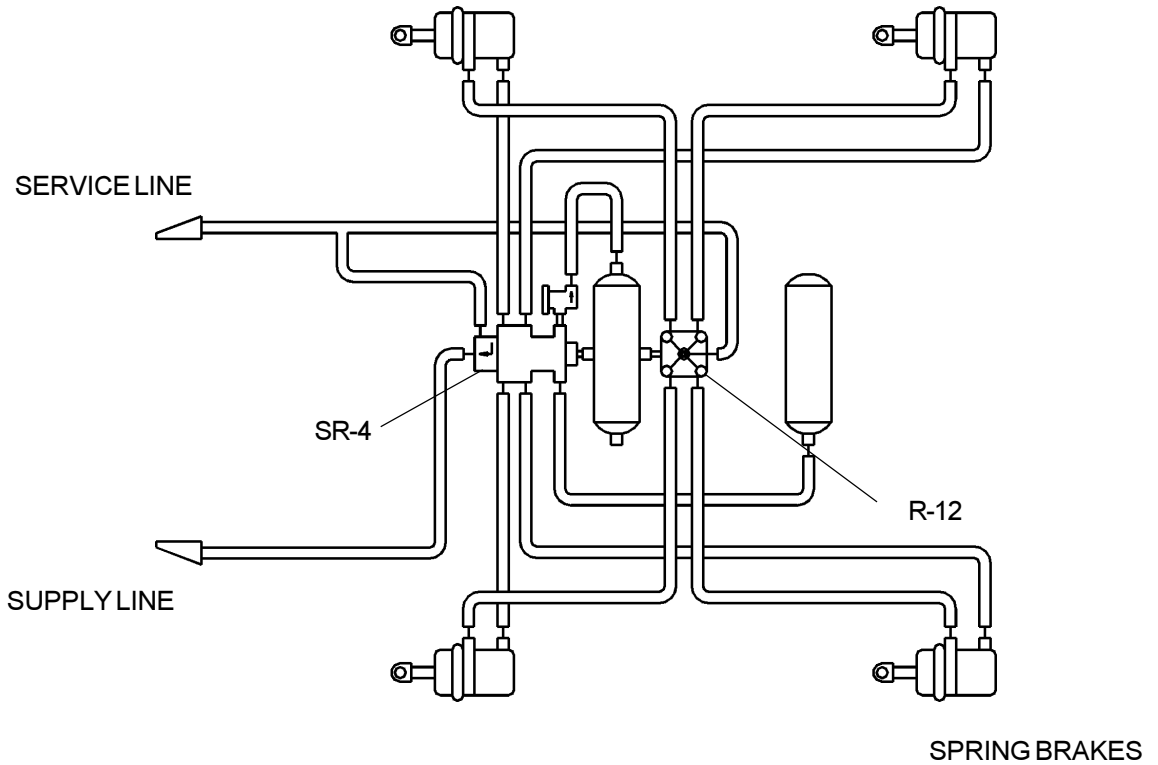
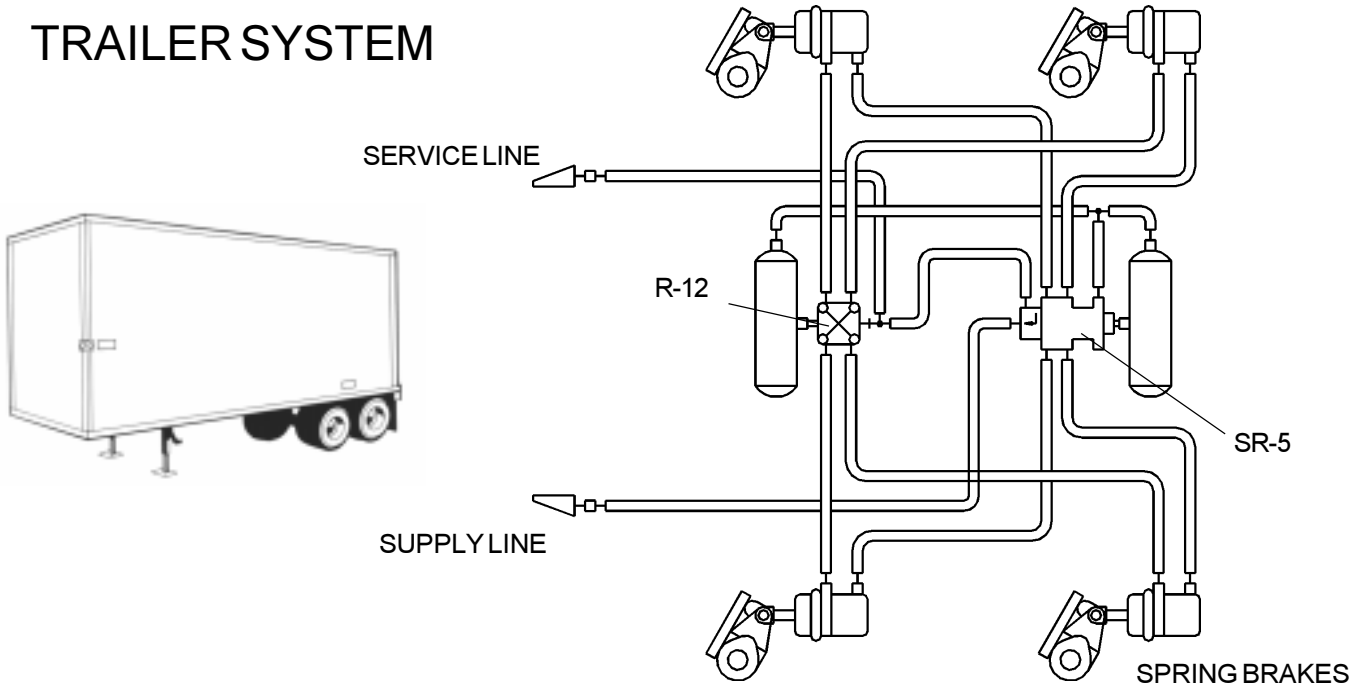

## TRAILER SYSTEM-GUARD® AIR DRYER

The Trailer System-Guard® Air Dryer removes moisture and contaminants from the trailer air system. It is not intended to take the place of a dryer normally located on the power unit. It acts as a buffer to remove moisture during wet times and gives up moisture during dry times. It protects the trailer air brake system when, for short periods of time, the trailer is pulled by vehicles without an air dryer or during times when the trailer is disconnected from the tractor.



**TRAILER SYSTEM-GUARD®  
AIR DRYER**

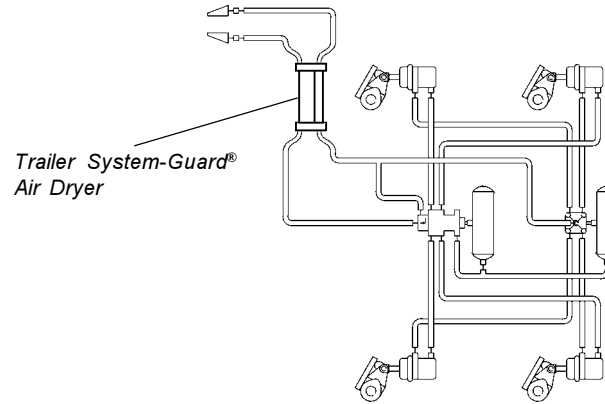

---

## SR-2 and SR-4 TRAILER SPRING BRAKE VALVE

The **SR-2 and SR-4 spring brake valves** are designed for use in trailer air brake system. The SR-2 differs from the SR-4 in that it uses a dedicated spring brake reservoir for release of the trailer spring brakes while the SR-4 utilizes the service reservoirs for this purpose. Mounted on one of the trailer reservoirs, these valves control both the parking and the emergency brake functions of the spring brakes and using integral pressure protection and check valves they isolate reservoir failures preventing automatic application of the trailer spring brakes. An integral anti-compound feature is part of both valves.

Due to the changes brought about due to FMVSS 121, Docket 90-3, notice 4, the SR-4 is no longer used on new production trailers after 10/08/92 and was superseded by the SR-5. The SR-2 is still used on some new production vehicles. Replacement SR-4 valves are still available.



**SR-2**



**SR-4**

---

## RELAY EMERGENCY VALVES

Relay emergency valves are commonly used on pre-121 trailers and in current off-highway braking systems and trailer converter dollies. The relay emergency valve is a dual function valve. Under normal braking conditions, it serves as a relay valve, applying and releasing the service brakes. The emergency portion of the valve senses supply line pressure and should pressure in the supply line fall below a predetermined minimum, the valve will automatically apply the vehicle service brakes from its own protected reservoir.

The **RE-4 and RE-6 relay emergency valves** are piston operated and are available in both remote and reservoir mount configurations. Both valves provide easy removal of the inlet/exhaust valve cartridge assembly without line removal. The RE-4 and RE-6 are interchangeable in both fit and function.



**RE-6**

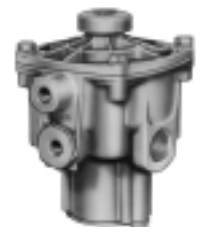

**RE-4**

# TOWING TRAILER

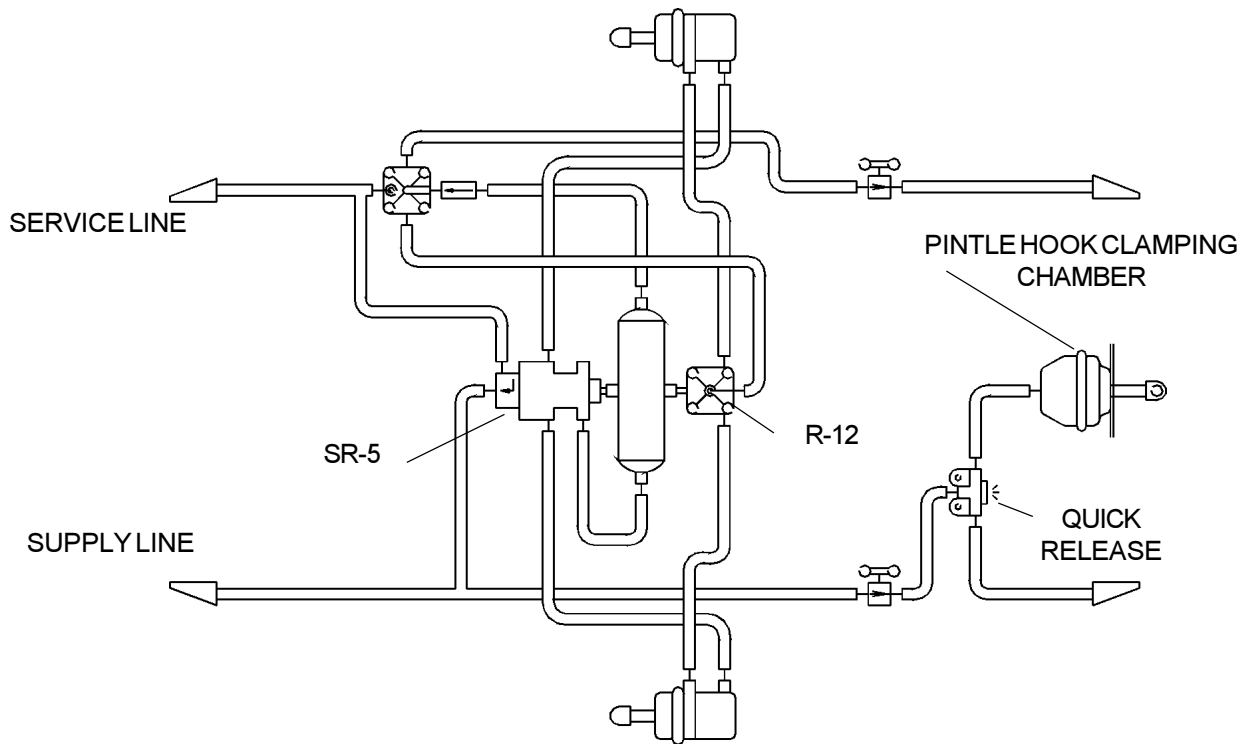

## SR-5 TRAILER SPRING BRAKE VALVE

The **SR-5 is a trailer spring brake control valve**. It mounts to a reservoir on the trailer and, like the SR-2 & 4, it controls the trailer spring brakes. The SR-5 is similar to the SR-2 and SR-4 but it allows for simpler trailer system plumbing while complying with the latest version of FMVSS 121 (Docket 90-3, Notice 4). However, unlike the SR-2 and SR-4, the SR-5 controls trailer spring brake release using trailer Supply Line pressure. Because dedicated or isolated reservoir pressure is no longer required by law for spring brake release, the SR-5 system needs only a one reservoir for service volume on single axle trailers. Two reservoirs are generally needed for 121 service volume requirements on tandem units. An integral anti-compound feature is part of the SR-5.

Older trailers using the SR-4 can easily be upgraded to the SR-5 with a minimum of repiping.

### IMPORTANT

The SR-5 is almost identical in appearance to the SR-2. The distinguishing characteristic of the SR-5 is a hole drilled into the flat surface between the pressure protection valve and the body.

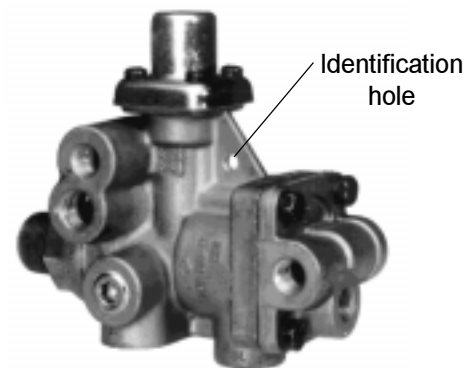

SR-5

# CONVERTER DOLLY

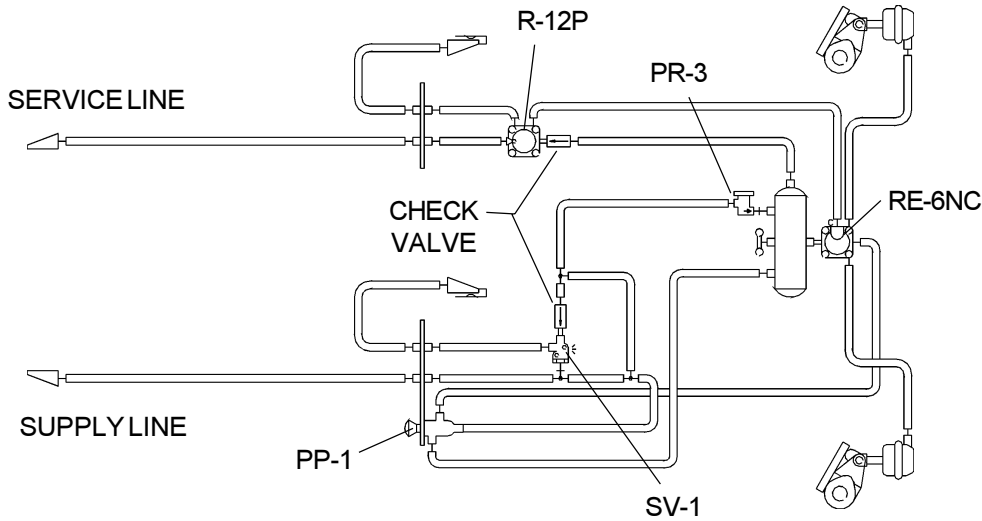

## PILOT OPERATED RELAY VALVES

The **R-8P and R-12P relay valves** are a special purpose relays designed specifically for use on trailers and converter dollies. These 0 p.s.i. crack and differential relays speed up brake application signals provide an equal or balanced pressure signal to all trailer and dolly brakes on double and triple trailer combinations. By maintaining the same application signal across the entire train of trailers these pilot operated relay valves aid in achieving overall vehicle brake balance and stability.



**R-12P  
RELAYVALVE**



**R-8P  
RELAYVALVE**

## SYNCHRO VALVE

The **SV-1 synchro valve** is a remote mounted air operated, ON-OFF control valve. It is used to control air from a remote supply, has a set opening and closing pressure and can be used to delay or sequence the action of other pneumatic devices. Use of the SV-1 in dolly or towing trailer system prevents automatic application of the towing (lead) trailer or dolly emergency brakes in the event a breakaway occurs with the towed (rear) trailer.



**SV-1  
SYNCHROVALVE**

## RELAY EMERGENCY VALVE (NON CHARGING)

The **RE-6NC relay emergency valve** is used in Dolly Systems and replaces the conventional RE-6. The RE-6NC is similar to the RE-6 but is designed to prevent direct filling of the dolly reservoir through the RE-6NC. It is generally used in conjunction with the PR-3 pressure protection and single check valve to provide rapid dolly brake release.



**RE-6NC**

## RESERVOIR CONTROL

The **PR-3 reservoir control valve** is the combination of a PR-4 pressure protection valve and a single check valve. This valve may be used in a variety of applications however the most common is in the converter dolly brake system where it functions to delay filling of the reservoir until pressure in the Supply air line exceeds 75psi and to prevent pressure loss due to a failure in the trailer being towed.



**PR-3**

## THE FUNDAMENTALS OF BRAKES

All types of automotive brakes are mechanical devices for retarding the motion of a vehicle by means of friction, and perhaps the most important requisite in respect to the fundamentals of brakes is an understanding of the laws of friction.

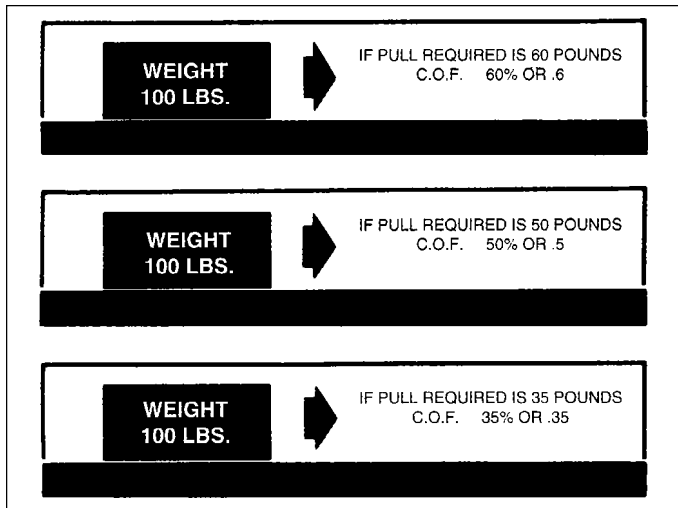

FIG. 1 - Coefficient of Friction

### COEFFICIENT OF FRICTION

Friction is the resistance to relative motion between any two bodies in contact, and it varies not only with different materials but also with the condition of the materials. The amount of friction developed by any two bodies in contact is said to be their coefficient of friction, and this is expressed by stating the amount of force required to move the one body while it remains in contact with the other; the amount of force being expressed in relation to the weight of the moving body.

Thus, if the moving body weighs 100 pounds, and a force of 60 pounds is required to keep it moving while it remains in contact with another body, the coefficient of friction between the two bodies is said to be 60% or .6. If 50 pounds force is necessary to keep it moving, the coefficient of friction is said to be 50% or .5. If only 35 pounds force is required, the coefficient of friction is 35% or .35.

The coefficient of friction between any two surfaces changes with any variation in the condition of one or both surfaces. As an example, the introduction of oil or grease between two dry, flat metal surfaces will greatly reduce the friction between them, which proves that the condition of these surfaces plays a great part in the actual friction they develop. This possible variation in the coefficient of friction is always present when any factor contributing to the frictional value of any material is subject to change either permanent or temporary.

Heat is always present where friction is being developed. For example, when a bearing is not properly lubricated, the lack of lubrication causes a rise in the coefficient of friction with a resultant rise in the heat that causes the bearing to fail.

### ENERGY OF MOTION TO HEAT ENERGY

Since friction is the resistance to relative motion between two bodies in contact and since friction results in heat, a more complete definition of a brake would be that it is a mechanical device for retarding the motion of a vehicle by means of friction, thereby changing the energy of motion into heat energy.

Thus, when the speed of a vehicle is reduced by applying the brakes, the energy of motion is actually changed into heat energy, and the brakes must dissipate or absorb the heat developed.

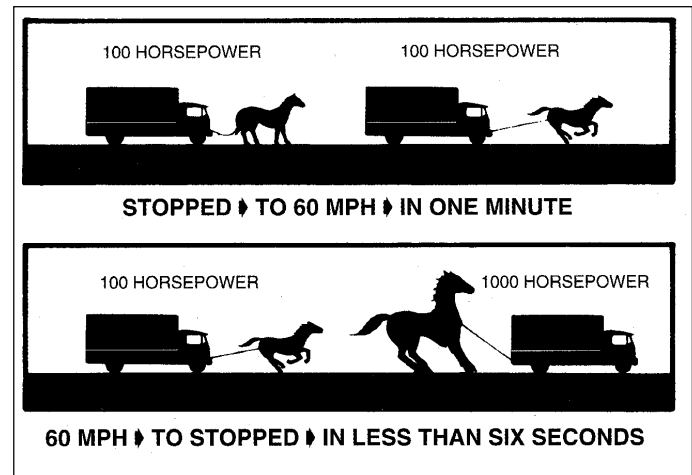

FIG. 2 - Forces Involved in Braking

### FORCES INVOLVED IN BRAKING

It is difficult to appreciate the tremendous forces involved in stopping a modern commercial vehicle, particularly from the higher speeds.

A simple method of explaining this is to make a comparison between the horsepower required to accelerate a vehicle and the horsepower required to stop it. A truck with an engine capable of developing 100 horsepower will require about one minute to accelerate to 60 miles per hour. The same vehicle should be capable of easily stopping from 60 miles per hour in not more than six seconds. Ignoring the unknown quantities, such as rolling friction and wind resistance which play a part in all stops, the brakes must develop the same energy in six seconds as the engine develops in 60 seconds; in other words, the brakes do the same amount of work as the engine in one-tenth the time and must develop approximately 1,000 horsepower during the stop.



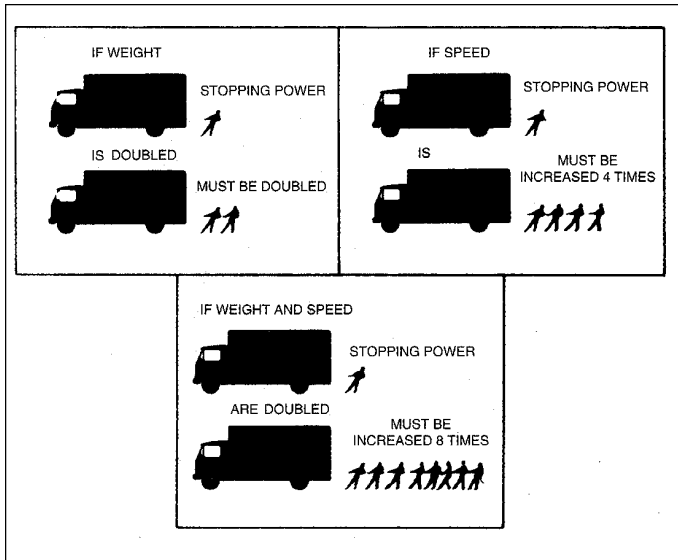

FIG. 3 Effect of Weight and Speed on Brakes

### EFFECT OF WEIGHT

Another factor to be considered is the effect on braking when the weight and speed of a vehicle are increased. Brake systems are designed to properly control a vehicle loaded to its gross vehicle weight (GVW). If the GVW is exceeded, braking performance is affected; if the weight of the vehicle is doubled, the energy of motion to be changed into heat energy is also doubled. The brake cannot properly dissipate and absorb the increased heat and braking performance of the vehicle is lessened.

### EFFECT OF SPEED

The effect of higher speeds on braking is much more serious. Not so many years ago the average speed of a commercial vehicle was only 20 miles per hour. Today, even conservative estimates place the average speed of commercial vehicles at 40 miles per hour. Comparing stops from a speed of 20 miles per hour with stops from a speed of 40 miles per hour, engineering calculations show there is actually four times as much energy of motion to be changed to heat energy during a stop from 40 miles per hour as there is during a stop from 20 miles per hour. Thus, if the speed is doubled, four times as much stopping power must be developed, and the brakes must absorb or dissipate four times as much heat.

It naturally follows that if both the weight and speed of a vehicle are doubled, the stopping power must be increased eight times and the brakes must absorb or dissipate eight times as much heat.

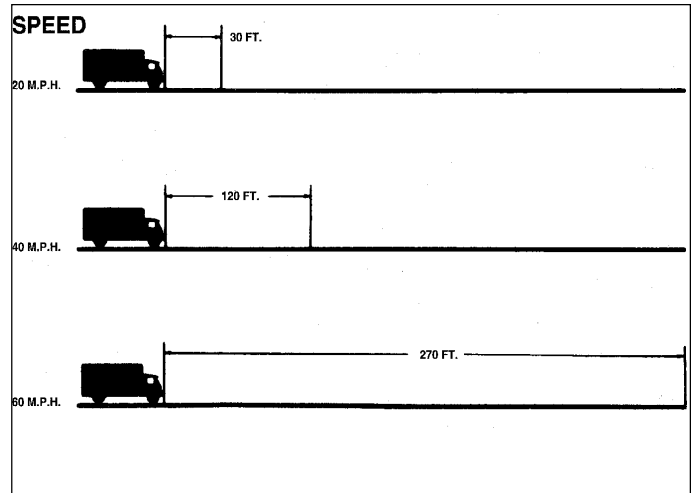

FIG. 4 - Stopping Distances

Another way of illustrating the effect of speed on stopping ability is to compare the stopping distance if the speed is increased without the stopping power also being increased.

As shown in Figure 4, a vehicle which will just stop in 30 feet from 20 miles per hour will require 120 feet to stop from 40 miles per hour and 270 feet to stop from 60 miles per hour. Introducing both weight and speed into the comparison again, a 10,000 pound vehicle traveling 60 miles per hour has 18 times as much energy of motion as a 5,000 pound vehicle traveling at 20 miles per hour. If a stopping power is used on both vehicles which will only stop the 5,000 pound vehicle from 20 miles per hour in 30 feet, the 10,000 pound vehicle from 60 miles per hour will require 18 times as much distance or 540 feet to stop.

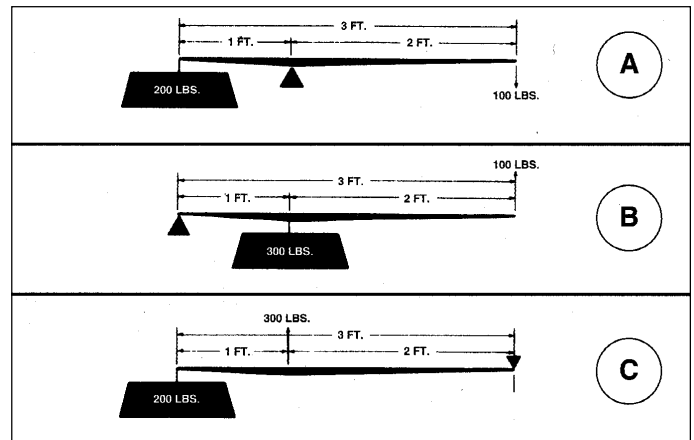

FIG. 5 - Leverage

### LEVERAGE

Having reviewed the forces involved in braking a vehicle, consideration must also be given to how these forces are developed and directed to do the braking work. It is difficult even to imagine a braking system which does not, in some way, make use of one of the oldest mechanical devices governing the transmission and modification of force and motion, the lever.

A lever is defined as an inflexible rod or beam capable of motion about a fixed point called a fulcrum, and it is used to transmit and modify force and motion.

Figure 5 illustrates three simple types of levers; the only difference in them being the location of the fulcrum in relation to the applied force and the delivered force. All shapes and sizes of levers used in a brake system are one of these three types.

The simple law of levers is that the applied force multiplied by the perpendicular distance between the line of force and the fulcrum always equals the delivered force multiplied by the perpendicular distance between the fulcrum and the line of force. Thus, with a leverage arrangement as shown in view 5A, an applied force of 100 pounds two feet from the fulcrum will give a delivered force of 200 pounds at a point one foot from the fulcrum. With a leverage arrangement as shown in Figure 5B, an applied force of 100 pounds three feet from the fulcrum will lift 300 pounds at a point one foot from the fulcrum.

Note that in both cases the delivered force exceeds the applied force because the applied force is farther from the fulcrum than the delivered force. With a leverage arrangement as shown in Figure 5C, the delivered force is the farthest from the fulcrum; therefore, it is less than the applied force. If the applied force in this case is 300 pounds at a point two feet from the fulcrum, the delivered force at a point three feet from the fulcrum will be 200 pounds.

The delivered force of any lever is determined by multiplying the applied force by the distance it is from the fulcrum and then dividing this answer by the distance the delivered force is from the fulcrum.

In determining the distance at which any force is acting on a lever, the true length of the lever arm is the perpendicular distance from the force to the fulcrum, regardless of the shape of the lever. The lever arm is always measured at right angles to the direction of the force.

The product of the force acting on a lever, multiplied by the distance the force is from the fulcrum, is called the turning moment, and when this relates to a shaft it is called torque. The turning moment or torque is usually expressed in inch pounds, foot pounds, foot tons, etc., depending upon whether the force is measured in pounds or tons and whether the distance is measured in inches or feet. As an example—a force of 100 pounds acting on a lever arm five inches long would result in a turning moment or torque of 500 inch pounds.

The most easily recognized lever in an air system is the slack adjuster. The length of the lever arm of a slack adjuster is always the perpendicular distance between the center line of the brake camshaft opening and the center line of the clevis pin opening in the arm.

Another form of lever—not always recognized—is the brake cam. All brake cams are levers and are used to transmit and modify the torque and turning motion of the brake camshaft in such a way that the brake shoes are spread and forced

against the brake drum, not only in the proper direction but also with the proper force. Spreading the shoes in the proper direction, of course, depends on the proper location of the cam in respect to the location of the brake shoes. The transmission of the proper force is partially determined by the effective lever length of the cam. If the effective lever length of the cam is not considered, and is too long or too short, the brake shoe force will be correspondingly too little or too much. Full consideration must therefore be given to the effective lever length of any brake cam, if the final shoe pressure is to be correct. It is also important that the effective lever length of the cam remains constant as the lining wears and the shoes have to be spread further; otherwise, the brake performance will vary as the lining wears.

Another form of lever found in all forms of braking systems is the brake shoe. This is one of the simpler forms because it is easily recognized as a beam, fulcrumed at one end on the hinge pin, which forces the brake lining against the drum when the brake cam force is applied to the other end.

Perhaps the least easily recognized lever in a brake system is the relation of the brake drum diameter to the tire diameter. In order to understand this fully it must be remembered that although the brakes stop the brake drums and wheels, it is always the tires and road surface that stop the vehicle. This is clearly demonstrated when quick stops are attempted on wet or icy roads. Under these conditions the brake equipment may still be as efficient as ever in stopping the wheels, but its ability to stop the vehicle quickly disappears because there is not sufficient friction between the tire and road to develop the necessary retarding force.

Returning to the principles of leverage involved in the relation of the tire and brake drum size, the retarding force developed by the brake shoes acting against the drum working on an effective lever length of the brake drum radius. Counteracting this is the retarding force developed between the tire and the road, working on an effective lever length of the rolling radius of the tire. Since it is not practical to have brake drums as large as the tires, the principles of leverage require development of a greater retarding force between the brake shoes and the drums than between the tire and the road. Also, since a rubber tire on a good road surface has a higher coefficient of friction than brake lining against a brake drum, it is necessary to develop additional retarding force between the brake shoes and brake drum in order to overcome the difference in friction.

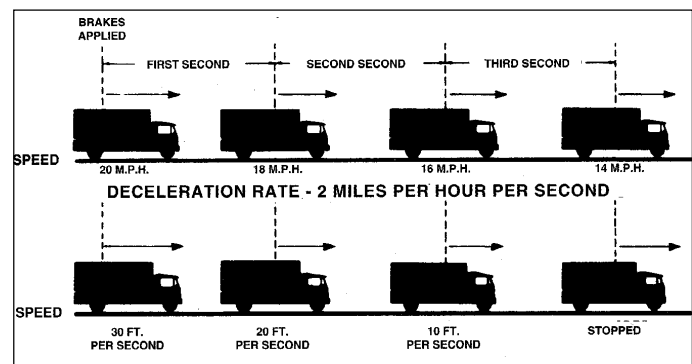

FIG. 6 - Deceleration

## DECELERATION

In discussing brakes, the term deceleration is often used. This term expresses the actual rate at which a vehicle loses speed and usually denotes the speed being lost each second, in terms of miles per hour or feet per second.

As an example as shown in Figure 6-if a vehicle is moving at the rate of 20 miles per hour, and one second later speed is only 18 miles per hour, the vehicle has lost a speed of two miles per hour during one second. Its speed has dropped two miles per hour in one second, therefore, its deceleration rate is two miles per hour per second.

In the same way, if a vehicle is moving at a rate of 30 feet per second, and one second later its speed is only 20 feet per second, then it is decelerating at the rate of ten feet per second per second.

Therefore, the change in the rate of speed of a vehicle during a slow-down or stop is expressed by first stating the rate of speed being lost, such as miles per hour or feet per second, and then by stating the time required for this rate of speed to be lost.

Thus, in examining the expression covering a deceleration rate of say, "ten feet per second per second," the first part-"ten feet per second"-is the rate of speed being lost, and the second part-"per second"-is the time in which the loss of ten feet per second takes place.

If a vehicle is moving at a known rate, and is decelerating at a known rate, the stopping time will be the initial speed divided by the deceleration rate, provided both the rate of speed and the deceleration rate are expressed on the same basis. As an example-if a vehicle is moving at the rate of 30 feet per second and is decelerating at the rate of ten feet per second, the stopping time will be the initial speed of 30 feet per second divided by the deceleration rate of ten feet per second per second, or a stopping time of three seconds.

This perhaps can be more easily understood if explained in the following manner; if a vehicle is moving at the rate of 30 feet per second and begins to decelerate at the rate of ten feet per second per second, at the end of the first second it will be traveling 20 feet per second; at the end of the second second, it will be traveling ten feet per second, and at the end of the third second, it will be stopped. Thus, by losing speed at the rate of ten feet per second per second, it would lose its initial speed of 30 feet per second in three seconds.

Similarly, if the initial speed is 20 miles per hour and the deceleration rate is two miles per hour per second, the stopping time will be ten seconds.

One important thing to remember in respect to stopping vehicles is the fact that while the deceleration rate may be constant for each second during the stop, the distance the vehicle travels each second during the stop varies greatly as the speed decreases.

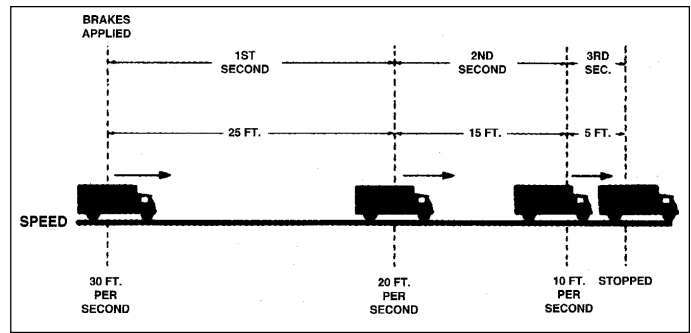

FIG. 7 - Deceleration

This is illustrated in Figure 7 which also shows a vehicle decelerating at the rate of ten feet per second per second from an initial speed of 30 feet per second, but the positions of the vehicles are shown in relation to the distance traveled each second during the stop. This shows that although the rate of deceleration remains constant throughout the stop, the vehicle actually travels 25 feet during the first second after the brakes were applied, 15 feet during the second second, and only five feet during the third second.

The distance being traveled each second during the stop is always greater at the beginning of the stop. To keep stopping distance as short as possible, it is important that the brakes become fully effective when the pedal is depressed by the driver.

Any time lost between the instant the brake pedal is depressed and the instant actual deceleration begins is important because the vehicle continues to travel at close to its initial speed. In this case, the loss of only one second between the instant the driver depresses the brake pedal and the point where the brakes are really applied will result in lengthening the actual stopping distance by 30 feet. Thus, if four seconds instead of three elapse between the instant the driver depresses the brake pedal and the instant the vehicle stops, the actual stopping distance will be increased from 45 feet to 75 feet. In other words, by reducing the stopping time under these conditions by only one second or 25%, the actual stopping distance is reduced by 30 feet or 40%.

It is this part of brake fundamentals which is not often considered in judging brake performance, particularly when different forms of brakes are involved. A common method of testing brakes is by the use of a decelerometer-a device that determines the maximum rate of deceleration developed during a stop and which shows a calculated stopping distance from a speed of 20 miles per hour based on the maximum rate of deceleration developed during a stop. Such instruments do not, however, make allowances for lost time before the braking system develops full power and therefore are not suitable for analyzing time lag factors in brake performance.

The true performance of any type of brake system in terms of stopping time or stopping distance can only be determined by actually measuring the time and distance the vehicle travels from the instant the driver depresses the brake pedal to the point where the vehicle actually stops. Such tests can, of course, be made comparative only by using instruments to

determine accurately the speed of the vehicle at the instant the brake pedal is depressed.

In so far as brakes are concerned, a driver is mainly interested in the amount of time and the distance required to bring his vehicle safely to a stop under emergency conditions as measured from the instant he depresses the brake pedal. Any lag in the time between the instant he does his part and the instant the brakes become effective affects stopping distance.

### **THE FUNDAMENTALS OF COMPRESSED AIR**

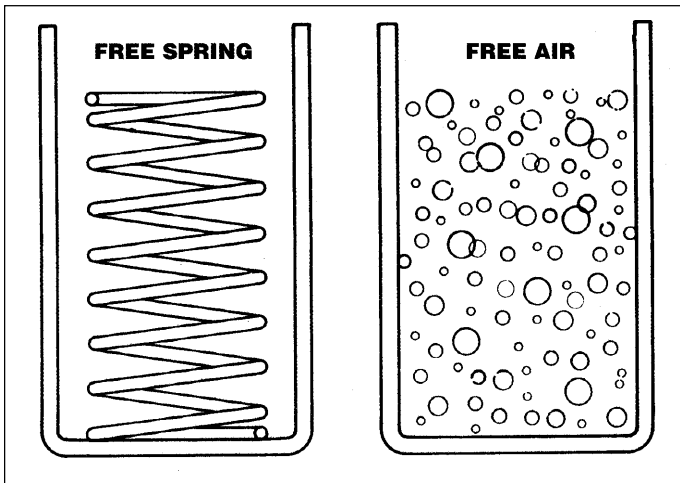

FIG. 8 - Free Spring / Free Air

Compressed air is air which has been forced into a smaller space than that which it would ordinarily occupy in its free or atmospheric state.

Free air which we breathe-or atmosphere-is normally always under pressure because of the weight of the air above it. This pressure amounts to 14.7 pounds per square inch at sea level, and it decreases as the altitude increases.

The normal atmospheric pressure of 14.7 pounds per square inch is usually ignored and the atmosphere is considered as being free air under no pressure. Thus, the pressure of compressed air is commonly indicated by stating the amount the pressure, in pounds per square inch, is above the atmosphere. This is the reason air pressure gauges register zero when connected only to atmosphere.

### **FREE SPRING - FREE AIR**

The energy of compressed air is best compared to the energy of a coiled spring. Figure 8 shows a coiled spring in its free position and air in its free or atmospheric state.

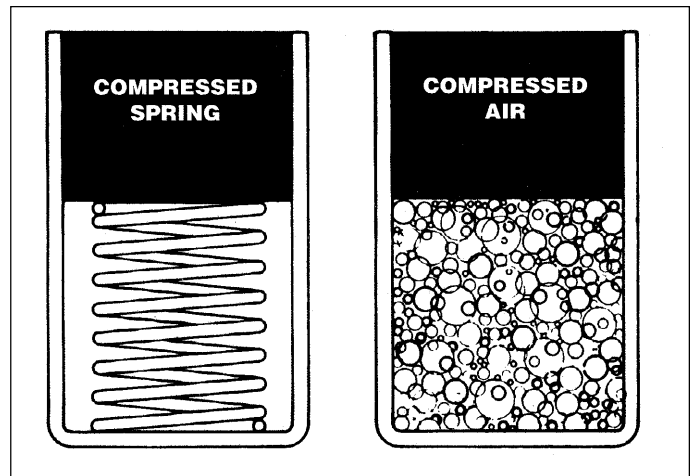

FIG. 9- Compressed Spring-Compressed Air

### **COMPRESSED SPRING- COMPRESSED AIR**

When the spring is compressed, as shown in Figure 9, energy is stored in it. Similarly when free air is compressed, energy is stored in the air. This energy can be used to do work, and due to the flexibility of air such energy can be stored in a relatively small space.

### **FUNDAMENTALS OF COMPRESSED AIR**

If two reservoirs are connected-one containing air above atmospheric pressure and the other air at only atmospheric pressure - air will flow from the reservoir charged with the higher pressure until the pressures in both reservoirs equalize or until the flow is interrupted by some outside force, such as the closing of a valve in the connecting line. This is similar to the action of liquids except that pressure is the controlling medium whereas the force of gravity would ordinarily be the controlling medium in the case of liquids.

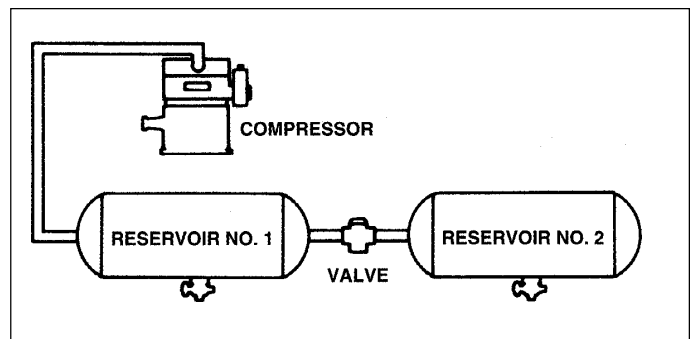

FIG. 10- Fundamentals of Compressed Air

As shown in Figure 10, if reservoir No. 1 has a volume of six cubic feet, and the compressor forced another six cubic feet of free air into it, the gauge pressure of the air in the reservoir, which originally read zero, would rise to 14.7 pounds. It follows that the more air that is forced into any reservoir the higher the air pressure in that reservoir will be, and that each time a quantity of free air equal to the volume of the reservoir is forced into it, the gauge pressure will rise another 14.7 pounds per square inch.

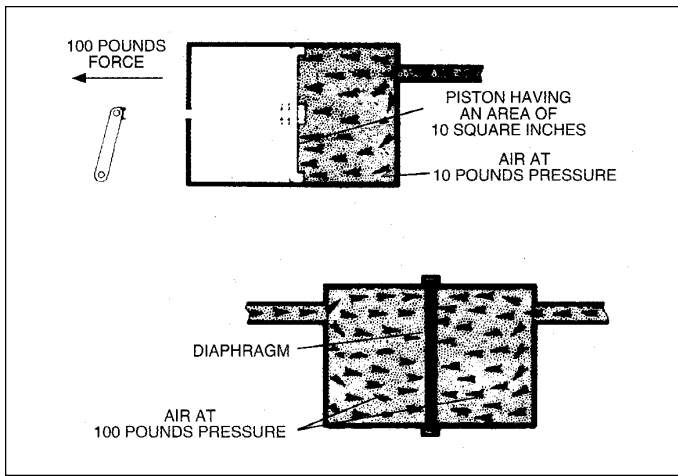

FIG. 11 - Fundamentals of Compressed Air

As illustrated in Figure 11, if compressed air is admitted to an airtight chamber behind a movable object, the compressed air will cause the movable object to move until it encounters a resistance equal to the force developed by the compressed air. Because the air pressure is based on pounds per square inch, it follows that the compressed air will develop a force in pounds on the movable object equal to the product of the air pressure multiplied by the effective area of the movable object. Thus, if a piston or a flexible diaphragm has an area of ten square inches and air at a pressure of ten pounds per square inch is acting upon it, a force of 100 pounds will be developed. Similarly, if air at only five pounds per square inch pressure is acting on the piston or diaphragm, the developed force will be only 50 pounds. One point to be remembered is that the quantity of air acting on the piston or diaphragm does not affect the force developed. The only factors involved are the air pressure and the area of the piston or diaphragm on which the air pressure is acting. Thus, by controlling the air pressure, the developed force is also controlled.

The pressure exerted by compressed air is not only developed in all directions, but it is also equal in all directions. The compressed air in a reservoir exerts pressure equally in all directions against the entire inside surface of the reservoir, the pressure of the compressed air being overcome by the mechanical strength of the reservoir. Similarly, the force developed by the air pressure acting on one side of a piston or a diaphragm may be overcome by an opposing force acting on the opposite side, and the opposing force may be compressed air or it may be mechanical. If the opposing forces are equal, a balanced condition is reached and there is no movement of the piston or diaphragm. If the opposing forces are not equal, the piston or diaphragm will move, if possible, to assume a position where the opposing forces are equal.

This law of balanced pressures and forces is the basic principle governing the design and operation of the control and actuating devices in an air brake system.

## THE FUNDAMENTALS OF COMPRESSED AIR BRAKES

### COMPRESSOR, RESERVOIR AND BRAKE VALVE

In an Air Brake system, the compressor furnishes the compressed air for brake operation by taking free air or atmosphere and compressing it to 100-120 P.S.I. (Maximum pressure in an air brake system is generally 150 P.S.I.)

The compressed air passes from the compressor into the reservoir where it (and its energy) are stored until needed. The compressed air is held in the reservoir until released by the driver operating air control valves.

### SERVICE BRAKE SYSTEM

When the brake valve is operated by the driver, air flows to the chambers where its energy is transformed into the mechanical force and motion necessary to apply the brakes.

### BRAKING FORCES-EFFECT OF AIR PRESSURE

This control of the braking force by controlling the air pressure in the chambers is illustrated in Figure 14. It shows the resulting forces in pounds of various air pressures with a chamber having an effective diaphragm area of 30 square inches.

The important point is that the air pressure in a brake chamber can be controlled so the brake chamber will develop the required force.

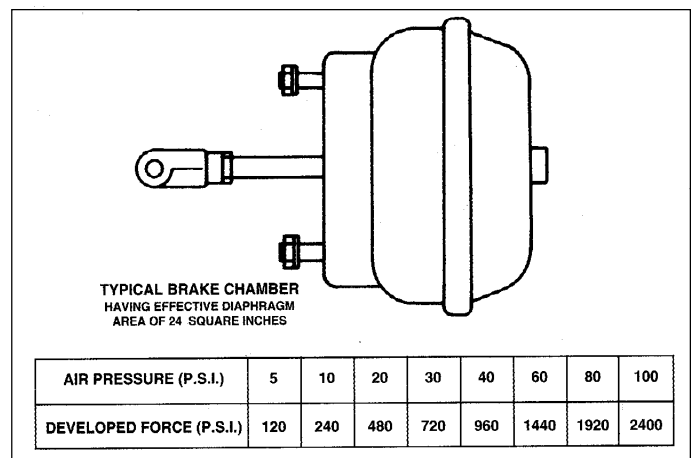

FIG. 14- Braking Forces-Effect of Air Pressure

### BRAKING FORCES-EFFECT OF BRAKE CHAMBER SIZE

Different sizes of vehicles and different axles of the same vehicle may require different braking forces, depending on the weight of the vehicle or the weight distribution between axles of the same vehicle. These variations in the braking force are design variations because the maximum and minimum force required must be properly provided before good performance can be obtained throughout the entire braking range.

Figure 15 illustrates the developed force in pounds of each of several different sizes of chambers when supplied with air pressure at 60 pounds per square inch. The effective area of the different brake chambers generally varies from six square inches to 36 square inches and their developed force at 60 pounds air pressure generally varies from 360 pounds to 2,160 pounds. This permits the choice of a chamber size suitable for properly operating any size or type of foundation brake.

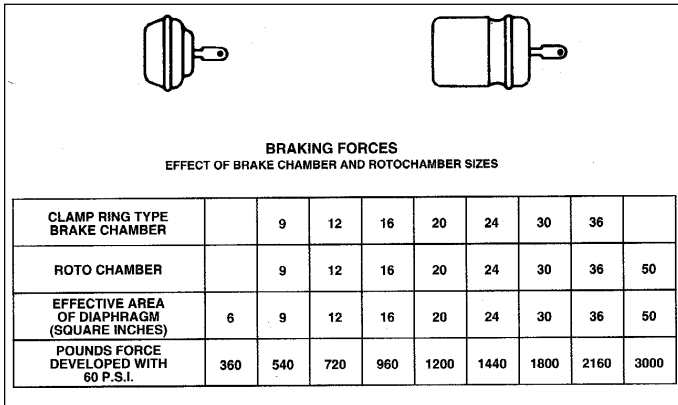

FIG. 15- Braking Forces-Effect of Brake Chamber Size

### BRAKING FORCES- EFFECT OF SLACK ADJUSTER ARM LENGTH

Figure 16 illustrates how the principles of leverage apply when a brake chamber and slack adjuster combination is being selected to meet specific requirements.

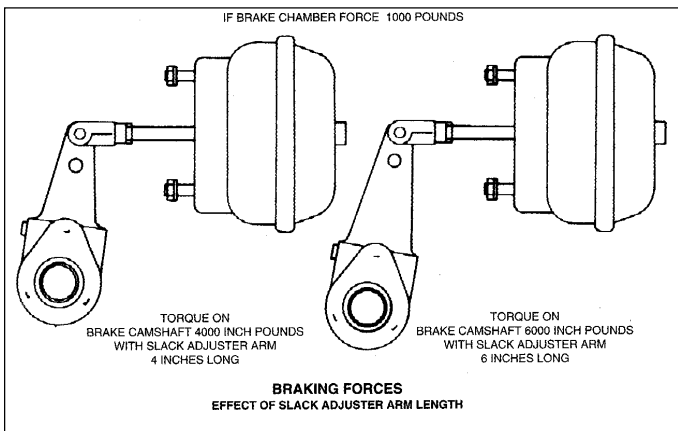

FIG. 16- Braking Forces-Effect of Slack Adjuster Arm Length

With the same brake chamber force of 1,000 pounds, the torque on the brake camshaft can be increased from 4,000 inch pounds to 6,000 inch pounds merely by using a slack adjuster with a 6" arm instead of one with a 4" arm.

In an S-Cam foundation brake, the full range of braking forces for any vehicle is provided by the use of different sizes of brake chambers and slack adjusters.

A term which is used to express the relation of the brake chamber size and slack adjuster arm length is "AL" factor. The "AL" factor differs from torque or turning moment in that only the variable factors which determine the force are

expressed. The reason for this is that an air pressure of 60 pounds is generally used in calculating air braking forces and therefore, is considered constant. The length of the slack adjuster lever arm and the size or effective area of the brake chamber acting on the slack adjuster are the two variables altered to meet braking requirements. The product of the effective area of the brake chamber and the length of the slack adjuster arm is expressed as the "AL" factor, which, when multiplied by the 60 pounds air pressure used in making brake calculations, determines the torque on the brake camshaft. As an example: If a brake chamber having an effective area of 16 square inches is acting on a slack adjuster having an arm length of five inches, the "L" factor is 80. The actual torque on the brake camshaft is therefore the "AL" factor (80) multiplied by the air pressure used in making brake calculations (60), or 4,800 inch pounds.

### BRAKING-FORCES-WEDGE BRAKES

Wedge brakes use the wedge effect to accomplish force multiplication. This replaces the leverage and torque principle of the slack adjuster applied in the S-cam brakes. The wedge brake uses linear (straight line) motion

to spread the brake shoes apart; unlike the Scam brake which uses torque to turn an "S" shaped cam, spreading the brakes shoes. The wedge angle determines the force multiplication factor. A thinner wedge and smaller wedge angle produces more force multiplication. Figure 17 (a & b) illustrates this point. A 1,000 lb. chamber force producing 5,720 lbs. of force into each shoe. Figure 17(b) illustrates an 18 degree wedge angle producing 3,184 lbs. of force into each shoe.

To tailor the braking forces to the requirements of any vehicle, chamber sizes and wedge angle combinations are varied. Figure 20 illustrates the effect of these combinations, as chamber sizes increase and wedge angles decrease, the multiplication or power factor increases.

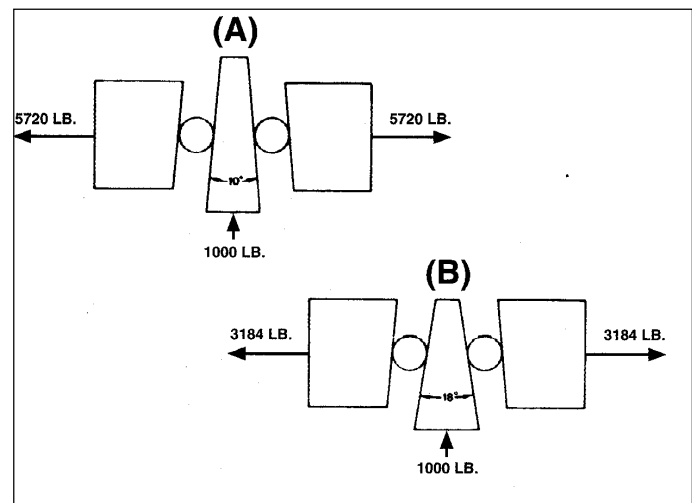

FIG 17 - Braking Forces-Effect of Wedge Angle

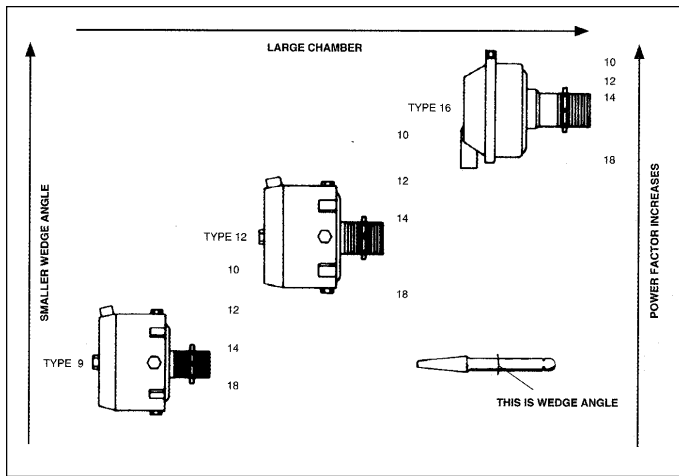

FIG. 18 - Wedge Brake Power Combinations

## Air Brake System Balance

The air-brake system is the most important safety system on a vehicle. Yet, the maintenance of the system is fairly simple job, capable of being performed by an air brake mechanic with the use of ordinary shop tools. Maintenance of the system can be broken down into two major areas: I. Pneumatics (Air) II. Mechanical. Component replacement and general brake system maintenance influence brake balance. Routine system maintenance operations should be performed with this in mind. The following contains a few "tips" to keep in mind.

### I. Pneumatics

#### General

An ideal or balanced braking system can be defined as one in which the braking pressure reaches each actuator at the same time and at the same pressure level.

#### Transmission time

Vehicle manufacturers must comply with the air system timing requirements of FMVSS 121. In establishing this performance, vehicle manufacturers carefully select tubing and hose sizes. Air application and release performance is partially dependent upon the size and volume of chambers, vehicle weights and locations of the valves and chambers, or distance the air must travel. Performance is engineered into the vehicle by the manufacturer; the role of the vehicle owner and/or mechanic is to preserve that pneumatic performance. Here are a few tips to assist in that effort.

**Tubing** - When replacing tubing or hose, always replace with the same size. These sizes have been determined by the vehicle manufacturer to obtain desired performance. If copper tubing is used, always make sure to ream and de-burr the tubing after cutting. Check carefully for restrictions such as kinking or bending, and make sure tubing and hose are properly supported. Use the proper size fittings and make certain they are not restricted. Do not replace straight fittings with elbows without considering that it takes as much time for air to flow through a elbow fitting as through 6-7 feet of tubing or hose!

**Valving** - When replacing valves in the air brake system, be sure that the function of the replacement valve is comparable with the valve being replaced. While many valves can be replaced with a different brand, make certain the new valve is at least equal in performance. Bendix, along with some

suppliers, adheres to an industry recommendation which requires that the valve type and some its critical characteristics be identified by a metal tag or washer. This is done to assist in the operator in choosing the correct replacement.

### Air System Contamination

As the complexity of the air brake system has increased, so has the need for clean air. The contaminants that collect in the air brake system consist of water condensed from the air and a small amount of oil from the compressor. These contaminants pass into the system in both liquid and vapor form because of the heat generated during compression. While the majority of contamination condenses in the reservoir a substantial amount finds its way into the brake system valving.

In addition, the prevention of freeze-ups in the system is an equally important concern. The development of the Air Dryer has all but eliminated contamination and freeze-up concerns because of its ability to provide clean, dry air to the brake system.

If, for whatever reason, an air dryer is not in use daily reservoir draining can help reduce the amount of contamination that resides in the system. While reservoir draining can not eliminate valve contamination it can reduce the amount. Alcohol evaporators can help in preventing freeze-ups in systems not equipped with an air dryer.

### II. Mechanical

#### General

Vehicle manufacturers must also comply with the braking performance requirements of FMVSS 121. As with the air or pneumatic side of the system, the vehicle manufacturer must carefully design the brake geometry, size and power of the foundation brake components to achieve the desired level of performance. Maintenance personnel must likewise strive to maintain this performance.

**Brake Chambers and Actuators** - Brake chambers convert air pressure into mechanical force. Always maintain the chambers to their original performance condition. If chamber return springs need replacement, the springs should be replaced with springs of the proper spring load. When replacing, remember the chamber return spring affects the net force delivered by the chamber, and is especially important in low service brake applications. For this reason always replace the return spring on both chambers on an axle.

Chamber diaphragm life will vary according to the type of service and the diaphragm environment. Experience will generally dictate replacement frequency, and it is good practice to replace all diaphragms on the vehicle at the same time.

Also, make sure the chamber push rods are in line with the slack adjusters. If misalignment is severe, the chamber rod can rub on the chamber non-pressure plate and cause a dragging brake.

Another factor that influences the brake chamber output force is the chamber push rod length. Ideally, the push rod length should be adjusted so that when the chamber reaches half its maximum stroke a 90 degree angle is formed between the slack adjuster and chamber push rod.

**Foundation Brakes** - Braking torque is established by the vehicle manufacturer and is determined by the designed axle weight. Brake size (diameter), brake block characteristics and the foundation brake design (cam, wedge, disc, etc.) influence brake torque. The torque is carefully evaluated in relation to drum capacity, drum area and lining area. It is recommended that you consult the vehicle manufacturer before attempting changes that would affect brake torque.

Mechanical friction within the foundation brake can affect brake output torque. The components of the foundation brake are subject to high forces and should be periodically checked and lubricated as necessary.

Friction material or brake block and lining segments affect vehicle stopping performance and are a factor in wear balance from front to rear. Replacement material should be chosen for its stopping performance as well as wear characteristics. At the minimum, always replace friction material on both ends of an axle. An even better practice is to replace material on all rear axles.

**Brake Adjustment** - One of the most important factors in obtaining maximum mechanical output of the chamber is proper brake adjustment. All chamber strokes should be adjusted to approximately the same stroke, and the adjustment should be made so that the chamber stroke is as short as possible without the brakes dragging. Improperly adjusted brakes waste air, leverage and contribute to poor brake performance. In many cases, complaints of poor or insufficient brakes can be taken care of by proper brake adjustment.

## **Brake System Maintenance**

Because no two vehicles operate under identical conditions, maintenance and maintenance intervals will vary. Experience is a valuable guide in determining the best maintenance interval for any one particular operation. In general the best method for determining the overall condition of the air brake system and to quickly locate problem areas is to perform the five tests presented in the **BRAKE SYSTEM TROUBLE-SHOOTING** section that follows. The tests check both leakage and device function and the accompanying check lists provide help in locating specific devices that are leaking or malfunctioning. Performing these tests on a quarterly basis and filing the results of the tests in the vehicle maintenance folder will provide a valuable basis of performance comparisons and trends. Maintenance intervals can be developed from these records as well.

## **GENERAL MAINTENANCE PRECAUTIONS FOR MAINTAINING AIR BRAKE SYSTEMS**

When working on or around a vehicle, the following general precautions should be observed.

1. Park the vehicle on a level surface, apply the parking brakes, and always block the wheels.
2. Stop the engine when working around the vehicle.
3. Drain the air pressure from all reservoirs before beginning ANY work on the vehicle.
4. Following the vehicle manufacturer's recommended procedures, deactivate the electrical system in a manner that removes all electrical power from the vehicle.
5. When working in the engine compartment the engine should be shut off. Where circumstances require that the engine be in operation, **EXTREME CAUTION** should be used to prevent personal injury resulting from contact with moving, rotating, leaking, heated, or electrically charged components.
6. Never connect or disconnect a hose or line containing pressure; it may whip. Never remove a component or plug unless you are certain all system pressure has been depleted.
7. Never exceed recommended pressures and always wear safety glasses.
8. Do not attempt to install, remove, disassemble or assemble a component until you have read and thoroughly understand the recommended procedures. Use only the proper tools and observe all precautions pertaining to use of those tools.
9. Use only genuine Bendix replacement parts, components, and kits. Replacement hardware, tubing, hose, fittings, etc. should be of equivalent size, type, and strength as original equipment and be designed specifically for such applications and systems.
10. Components with stripped threads or damaged parts should be replaced rather than repaired. Repairs requiring machining or welding should not be attempted unless specifically approved and stated by the vehicle or component manufacturer.
11. Prior to returning the vehicle to service, make certain all components and systems are restored to their proper operating condition.



# TRUCK/TRACTOR SYSTEM

# TRAILER SYSTEM

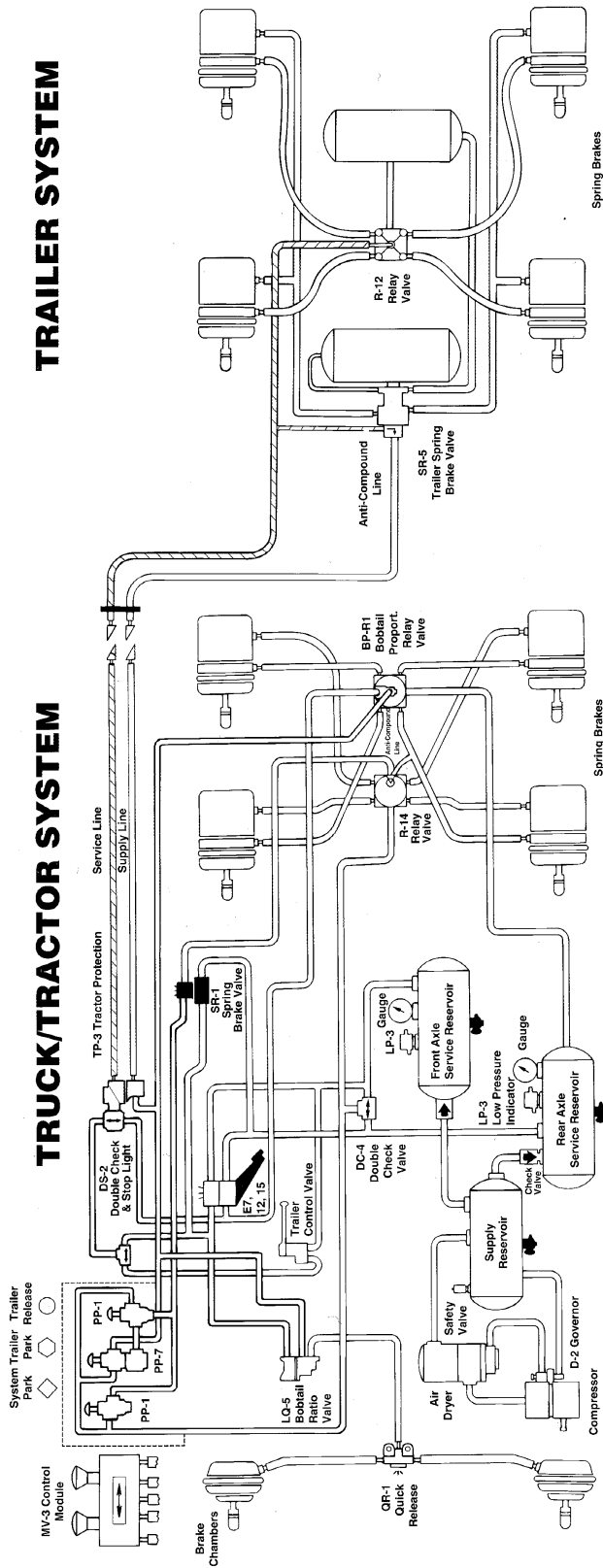

# TOWING TRAILER

# CONVERTER DOLLY

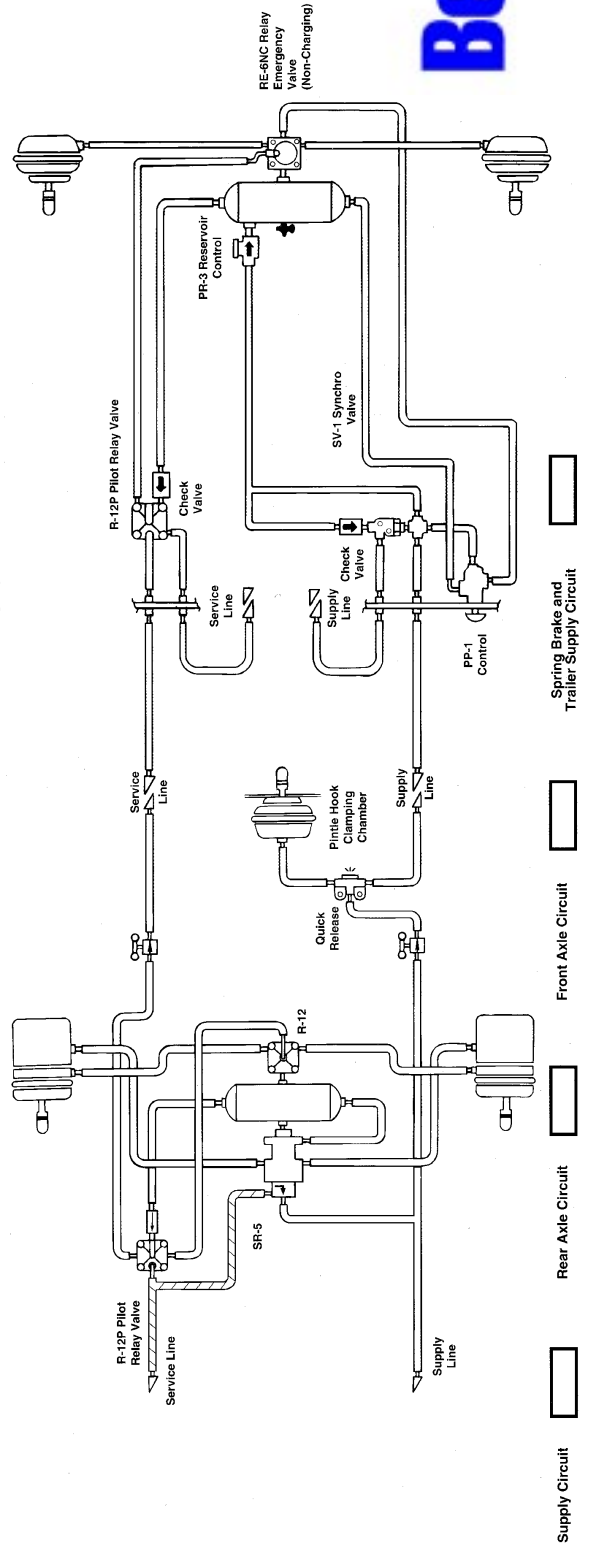

## BRAKE SYSTEM TROUBLESHOOTING

### Test 1

#### GOVERNOR CUT-OUT / LOW PRESSURE WARNING / PRESSURE BUILD-UP

VEHICLE PARKED, WHEELS CHOCKED

|  | OK                       | NOT<br>OK                |
|--|--------------------------|--------------------------|
| 1. Drain all reservoir to 0 PSI  |                          |                          |
| 2. Start engine (run at fast idle) (Low pressure warning should be on. Note: on some vehicles with anti-lock, warning light will also come on momentarily when ignition is turned on.) |                          |                          |
| 3. Low pressure warning (Dash warning light should go off at or above 60 PSI)  | <input type="checkbox"/> | <input type="checkbox"/> |
| 4. Build up time (Pressure should build from 85-100 PSI within 40 seconds)   | <input type="checkbox"/> | <input type="checkbox"/> |
| 5. Governor cut-out Cuts out at correct pressure (Check manufacturers recommendations; usually between 100-130 PSI)  | <input type="checkbox"/> | <input type="checkbox"/> |
| 6. Governor cut-in Reduce service air pressure to governor cut-in. The difference between cut-in and cut-out pressure must not exceed 25 PSI.  | <input type="checkbox"/> | <input type="checkbox"/> |

**MAKE ALL NECESSARY REPAIRS BEFORE PROCEEDING TO TEST 2; SEE CHECKLIST 1 FOR COMMON CORRECTIONS.**

#### Check List 1

**If the low pressure warning light or buzzer doesn't come on:**

1. Check wiring.
2. Check bulb.
3. Repair or replace the buzzer, bulb or low pressure warning switch(es).

**If governor cut-out is higher or lower than specified by the vehicle manual:**

1. Adjust the governor using a gauge of known accuracy.
2. Repair or replace governor as necessary after being sure compressor unloader mechanism is operating correctly.

**If low pressure warning occurs below 60 PSI:**

1. Check dash gauge with test gauge known to be accurate.
2. Repair or replace the faulty low pressure indicator.

**If build up time exceeds 40 seconds or is considerably greater than the permanent record figure:**

1. Examine the compressor air strainer and clean or replace.
2. Check for restricted inlet line if compressor does not have strainer, repair or replace as necessary.
3. Check compressor discharge port and line for excessive carbon. Clean or replace as necessary.
4. With system charged and governor compressor in unloaded mode, listen at the compressor inlet for leakage. If leakage can be heard apply a small amount

of oil around unloader pistons. If no leakage is indicated, then leakage is through the compressor discharge valves.

5. Check the compressor drive for slippage.

**RETEST TO CHECK OUT ALL ITEMS  
REPAIRED OR REPLACED**

### Test 2

#### LEAKAGE (RESERVOIR AIR SUPPLY)

|   | OK                       | NOT<br>OK                |
|---|--------------------------|--------------------------|
| FULL PRESSURE, ENGINE STOPPED,<br>PARKING BRAKES APPLIED  |                          |                          |
| 1. Allow pressure to stabilize for at least 1 minute.   |                          |                          |
| 2. Observe the dash gauge pressures for 2 minutes and note any pressure drop.                                   |                          |                          |
| A. Pressure Drop: Single Vehicle (A 2 PSI drop within 2 minutes is allowable for either service reservoir)      | <input type="checkbox"/> | <input type="checkbox"/> |
| B. Pressure Drop: Tractor/Trailer (A 6 PSI drop within 2 minutes is allowable for either service reservoir)     | <input type="checkbox"/> | <input type="checkbox"/> |
| C. Pressure Drop: Tractor/2 Trailers (An 8 PSI drop within 2 minutes is allowable for either service reservoir) | <input type="checkbox"/> | <input type="checkbox"/> |

**MAKE ALL NECESSARY REPAIRS BEFORE PROCEEDING TO TEST 3; SEE CHECK LIST 2 FOR COMMON CORRECTIONS.**

#### Check List 2

**IF THERE IS EXCESSIVE LEAKAGE IN THE SUPPLY SIDE OF THE PNEUMATIC SYSTEM, ONE OR MORE OF THE FOLLOWING DEVICES COULD BE CAUSING THE PROBLEM:**

NOTE: (A leak detector or soap solution will aid in locating the faulty component)

1. Supply lines and fittings (tighten)
2. Low pressure indicator(s)
3. Relay valves (antilock modulators)
4. Relay valve (an option for spring brakes)
5. Dual brake valve
6. Trailer control valve
7. Park control valve
8. Tractor protection valve
9. Spring brake actuators
10. Safety valve in supply reservoir
11. Governor
12. Compressor discharge valves

**RETEST TO CHECK OUT ALL  
ITEMS REPAIRED OR REPLACED**

### Test 3

#### LEAKAGE SERVICE AIR DELIVERY

|   | OK | NOT<br>OK |
|---|----|-----------|
| FULL PRESSURE, ENGINE STOPPED<br>PARKING BRAKES RELEASED  |    |           |
| 1. Make and hold 80-90 PSI brake application (A block of wood can be used to hold the foot valve down during these tests) |    |           |
| 2. Allow pressure to stabilize for 1 minute; then begin timing for 2 minutes while  |    |           |

OK NOT  
OK

watching the dash gauges for a pressure drop.

- A. Pressure Drop: Single Vehicle (A 4 PSI drop within 2 minutes is allowable for either service reservoir)
- B. Pressure Drop: Tractor/Trailer (A 6 PSI drop within 2 minutes is allowable for either service reservoir)
- C. Pressure Drop: Tractor/2 Trailers (An 8 PSI drop within 2 minutes is allowable for either service reservoir)

3. Check brake chamber push rod travel (Refer to chart for allowable tolerances)

| Brake Chamber Size | Maximum Stroke Before Readjustment |
|--------------------|------------------------------------|
| 12                 | 1 1/8"                             |
| 16                 | 1 3/4"                             |
| 20                 | 1 3/4"                             |
| 24                 | 1 3/4"                             |
| 30                 | 2"                                 |

4. Check the angle formed between the brake chamber push rod and slack adjuster arm. (It should be at least 90° in the fully applied Position)

**MAKE ALL NECESSARY REPAIRS BEFORE PROCEEDING TO TEST 4; SEE CHECKLIST 3 FOR COMMON CORRECTIONS**

**Check List 3**

**If there is excessive leakage in the service side of the pneumatic system, one or more of the following devices could be causing the problem.**

NOTE: A leak detector or soap solution will aid in locating the faulty component

- 1. Service lines and fittings (tighten)
- 2. Trailer control valve
- 3. Stoplight switch
- 4. Brake chamber diaphragms
- 5. Tractor protection valve
- 6. Relay valves (antilock modulators)
- 7. Service brake valve
- 8. Front axle ratio valve (optional)
- 9. Inverting relay spring brake control valve (optional) straight trucks and busses
- 10. Double check valve.

If the angle between the brake chamber push rod and slack adjuster arm is less than 90° then adjust slack adjuster arm to obtain desired setting.

If brake chamber push rod travel exceeds the allowable tolerance, then adjust adjuster arm to obtain desired setting.

**RETEST TO CHECK OUT ALL ITEMS REPAIRED OR REPLACED**

**Test 4**

**MANUAL EMERGENCY SYSTEM**

FULL PRESSURE, ENGINE IDLING 600-900 RPM

NOT FOR STRAIGHT TRUCKS, BUSES AND BOBTAIL TRACTOR:

1. Manually operate the park control valve and note that parking brakes apply and release promptly as control valve button is pulled out and pushed in.

FOR TRACTOR/TRAILER COMBINATIONS:

- 1. Manually operate tractor protection control valve (trailer supply valve usually red octagonal button). Note that trailer brakes apply and release promptly as control button is pulled out and pushed in.
- 2. Manually operate system park control (usually yellow diamond button) and note all parking brakes (tractor and trailer) apply promptly.

**MAKE ALL NECESSARY REPAIRS BEFORE PROCEEDING TO TEST 5; SEE CHECKLIST 4 FOR COMMON CORRECTIONS**

**Check List 4**

**If sluggish performance is noted in either test, check for:**

- 1. Dented or kinked lines
- 2. Improperly installed hose fitting
- 3. A faulty relay emergency valve
- 4. A faulty modulator(s)

**If the trailer brakes do not actuate and the trailer supply line remains charged, check the:**

- 1. Tractor protection control
- 2. Trailer spring brake valve

**RETEST TO CHECK OUT ALL ITEMS REPAIRED OR REPLACED**

OK NOT  
OK

**Test 5**

**AUTOMATIC EMERGENCY SYSTEM**

FULL PRESSURE, ENGINE STOPPED

- 1. Drain front axle reservoir to 0 PSI.
  - A. Rear axle reservoir should not lose pressure
  - B. On combination vehicles, the trailer air system should remain charged
  - C. Tractor and trailer brakes should not apply automatically
- 2. With no air pressure in the front axle reservoir make a brake application.
  - A. Rear axle brakes should apply and release
  - B. On combination vehicles the trailer brakes should also apply and release

|  | OK                       | NOT<br>OK                |
|--|--------------------------|--------------------------|
| C. The stop lamps should light   | <input type="checkbox"/> | <input type="checkbox"/> |
| 3. Slowly drain rear axle reservoir pressure.  |                          |                          |
| A. Spring brake push pull valve should pop out between 35 & 45 PSI.  | <input type="checkbox"/> | <input type="checkbox"/> |
| B. Tractor protection valve should close between 45 PSI and 20 PSI and trailer supply hose should be exhausted                       | <input type="checkbox"/> | <input type="checkbox"/> |
| C. Trailer brakes should apply after tractor protection closes   | <input type="checkbox"/> | <input type="checkbox"/> |
| 4. Close drain cocks, recharge system and drain rear axle reservoir to 0 PSI.  | <input type="checkbox"/> | <input type="checkbox"/> |
| A. Front axle reservoir should not lose pressure   |                          |                          |
| B. On combination vehicles the trailer air system should remain charged  | <input type="checkbox"/> | <input type="checkbox"/> |
| 5. With no air pressure in the rear axle reservoir, make a brake application.  | <input type="checkbox"/> | <input type="checkbox"/> |
| A. Front axle brakes should apply and release  |                          |                          |
| B. On combination vehicles the trailer brakes should also apply and release  | <input type="checkbox"/> | <input type="checkbox"/> |
| C. If the vehicle is equipped with an inverting relay spring brake control valve, the rear axle brakes should also apply and release | <input type="checkbox"/> | <input type="checkbox"/> |

### Check List 5

If the vehicle fails to pass the tests outlined, then check the following components for leakage and proper operation:

1. Fittings
2. Kinked hose or tubing
3. Single check valves
4. Double check valves
5. Tractor protection valve
6. Tractor protection control valve
7. Parking control valve
8. Relay valves (antilock modulators)
9. Trailer spring brake control valve
10. Inverting relay spring brake control valve (optional) straight trucks and buses

**RETEST TO CHECK OUT ALL ITEMS  
REPAIRED OR REPLACED**