



STAR CENTER NEWS

All Hands on Deck...We Have a New Captain at the Helm!

We have a new leader here at Technical Service Operations...Tom McCarthy is our new Vice President of Technical Service Operations.

Tom McCarthy hired into Chrysler in 1995 and has held many positions, each with increasing responsibility. The majority of his career was spent on the product development side of the company. In 2012, Tom was hired into Technical Service Operations as the Director of Technical Service Development. He most recently became Vice President of Technical Service Operations in December of 2014.

Tom holds a bachelor's degree in mechanical engineering from Northeastern University and a master's degree in business administration from Walsh College. His Interests are car racing, car restoration and animal (dog) rescue.

Tom brings with him a thorough knowledge of vehicle engineering and development processes and believes in the need to align Engineering and Service to provide better tools, information, equipment and support to the field/dealers to assist in fixing customer vehicles. Tom's vision for TSO is...focusing everything we do into fixing vehicles and improving the customer service experience.

Where to Find the STAR News...

The STAR News link has always been located in TechConnect on the home page, in the left-side window beneath the SEARCH Box. In addition STAR News will now be accessible through other communication channels including:

1. Link on the LMS (Academy Site)
2. Monthly Master Tech
3. Instructor Lead Training will include a reminder of electronic file location and hard copies, when possible
4. Via E-mail subscription – *details to follow on how to submit your E-mail address to receive an electronic copy of the STAR News.*

Something to say?

Send up your questions, comments, suggestions, etc...

STAR Center Manager
starmgmt@fcagroup.com
STAR News Feedback
starnews@fcagroup.com

STAR Center Hours of Operation
M-F 8am-Midnight * Sat 9am-6pm * Open thru Lunch



Top Tech Recognition

To kick off Mopar's new Technician Recognition Program, FCA US LLC recently awarded the Mopar "Top Techs" of 2014 with an all-inclusive two-day event at FCA Headquarters in Auburn Hills, Michigan. 27 Technicians (3 per business center) were selected from over 20,000 eligible technicians that showed exemplary performance in the areas of Fixed First Visit (FFV) scores, dealership tenure and training completion.



Top Techs group check out the wind tunnel at FCA headquarters in Auburn Hills, Mi.



As part of the two-day event, the technicians were special guests as they toured FCA's sci-lab, wind tunnel and the 5-million square-foot, world-class Sterling Heights Assembly Plant.

Service Procedure for KL Negative Battery Cable/IBS Module

Due to incidences of damage to the IBS module occurring during the performance of service procedures, please be sure to adhere to the following recommendations when removing and installing the negative battery cable/IBD module.

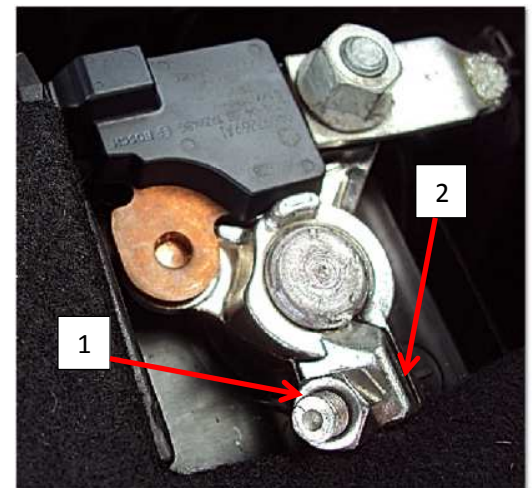

REMOVAL

1. Loosen M6 captive hex nut (1) without removing.
2. Insert medium-sized flat end of screwdriver in pole clamp slot (2).
3. Lightly tap screwdriver to open pole clamp slot to 3mm max.
4. Carefully lift IBS module upward to remove it from the negative battery post.

INSTALLATION

1. Place IBS module onto negative battery post and push down to ensure it is properly seated.
2. While applying downward force (20N max) on IBS module to prevent rotation, tighten M6 captive hex nut to 7Nm +/- 1Nm.

See service procedure in TechCONNECT for any additional details.



3.0L Diesel PM and NOx Sensor Removal Procedure Update

Some technicians are experiencing difficulty removing the PM and NOx sensors from the Selective Catalyst Reduction (SCR) during an SCR replacement.

There are updates to the SCR removal procedure and NOx Sensor removal procedure to help the technician successfully remove the sensors without damage.

- Only use a six-sided crow’s foot tool to remove the PM or NOx sensor from the SCR.
- If the PM or NOx sensor will not loosen, use a torque wrench (**Do not exceed 160 Nm (118 ft. lbs.)**) and attempt to loosen PM or NOx sensor.
- If the PM or NOx sensor fastener is still not loose after using the torque wrench method, use a heat gun to heat the sensor boss for 1 minute at 450° C (842° F). **NOTE: DO NOT use a torch as a heat source.**

See service procedure in TechCONNECT for any additional details.

New Field Technical Support Members

The Field Technical Support (FTS) Team would like to welcome three new Service Engineers to the group.

Patrick Waligore – Body/Chassis

Mike Russell – Diesel/Transmission

Bryan Green – Driveability/Engine/HVAC

Our new knowledge experts are looking forward to assisting the STAR Center, Tech Advisors and you with those difficult-to-diagnose vehicles.

PF Lighted Cluster Bezel Appearance

The lighted feature on the cluster bezel for the PF is not lit in the area above the steering wheel shroud by design (area in yellow below).

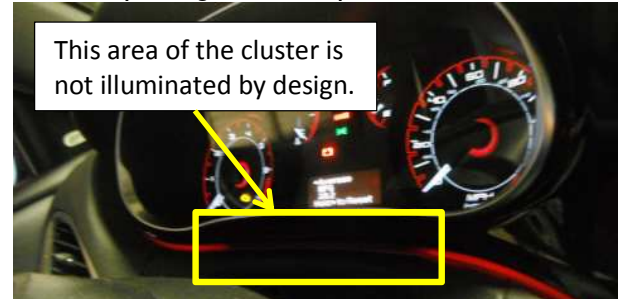

If a customer notes this, explain that it is by design intent and that all Darts equipped with the lighted bezel feature have this appearance. Comparison to another PF that is similarly equipped may be helpful.

Higher Shipping Pressure for Tires Prevents Flat Spots

FCA is making process changes to reduce customer complaints of vibration at highway speeds due to tire flat-spotting. Tire flat-spotting is the temporary flatness of the tire overlay construction that can occur during vehicle transportation and storage. Flat spotting can be driven out in 20 miles of highway driving. To minimize flat spotting, vehicles will be shipped at maximum sidewall pressures. FCA currently ships vehicles at maximum tire sidewall pressures with the exception of Heavy Duty Trucks.

Tire pressure should be left at maximum sidewall pressure during PDI in order to prevent flat-spotting during storage. When a vehicle is evaluated by or delivered to the customer, the tire pressure must be reduced to the proper cold tire inflation pressure that’s listed on the vehicle certification label. It’s located on the driver’s-side b-pillar or the rear edge of the driver’s-side door. Tire pressures not adjusted to placard pressure may cause a harsh ride condition.



Air Filter Fault or Filter Minder Warnings on 13 -14 M.Y. DJ, DD, DP, D2 with 6.7L Cummins

Some customers may experience a premature "Service Air Filter" message displayed on the EVIC. The mil may also be illuminated when this occurs. If the MIL is on, fault code P2280 - AIR FLOW RESTRICTION / LEAK BETWEEN AIR CLEANER AND MAF is likely to be set in the PCM. This condition may occur on vehicles with relatively low mileage.

The message in the EVIC as well as the DTC is intended to inform that the air filter has become restricted, requiring replacement. However, other inlet restrictions may also trigger the message and fault. Other possible causes are:

1. Debris blocking the Air Inlet Adapter or Ambient Air Duct (1) and (2).
2. Blocked air intake shield plastic tube (3).
3. Collapsed air intake shield porous tube (4).

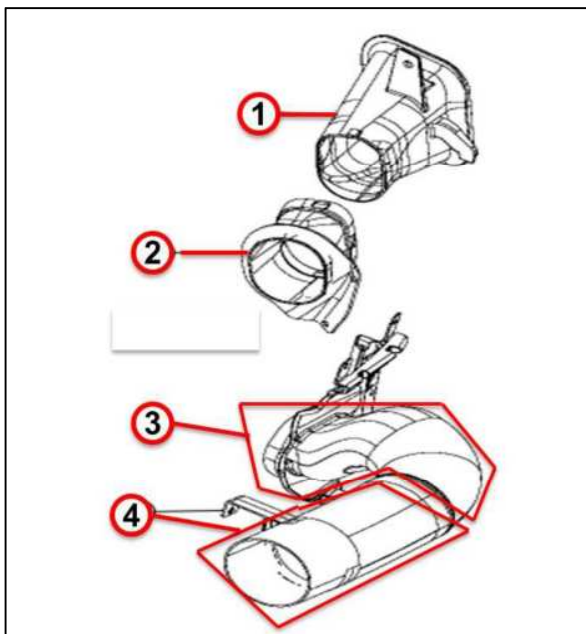

Before replacing the air filter, make sure to remove the inlet shield ducting (3 and 4) to the lower portion of the air box.

Inspect for signs of flashing material in the air intake shield plastic tube (3) (see photo below).



Also inspect for a collapsed air intake shield porous tube (4) (if equipped) (see photo below).



If both pieces have no problem found, replace the air filter.

LC/LA Challenger TR6060 6-Speed Manual Transmission 1 – 4 Skip Shift Feature

The TR6060 6-speed manual transmission in the 2009 – 2016 Challenger is equipped with a 1–4 Skip Shift feature. This is a solenoid-actuated transmission feature that guides the shift lever from 1st-to-4th gear under certain conditions to maximize fuel economy. **This is a normal function of the TR6060 6-speed manual transmission.**

"SHIFT" continued on next page



“SHIFT” continued from last page

When the following conditions are met, the shift mechanism will only allow shifts from 1st to 4th gear:

- Engine coolant temperature is higher than 106 F (41 C).
- Vehicle speed is greater than 19 mph (30 km/h) but less than 21 mph (34 km/h).
- The transmission is in first gear.
- The accelerator is at ¼ throttle or less.

After completing the shift from 1st to 4th gear, the clutch pedal can be depressed and the transmission can be shifted into another forward gear.

For customers who want to avoid the 1–4 Skip Shift, the most effective method is shifting at a higher or lower speed or applying additional throttle. Disconnecting the transmission solenoid wiring will cause a check engine light-on condition and set a fault code for P0803-Skip Shift Control Circuit to be set in the PCM. Therefore, this is not an acceptable way to disable the 1–4 Skip Shift feature.

Customers may be aware of a “Skip Shift eliminator kit” that is available from various sources in the aftermarket. Installation of this type of device on the TR6060 manual transmission is not authorized or recommended by Fiat Chrysler Automobiles.

6F24 Oil Pan Serviceability

If servicing a Dodge Dart, Jeep Compass or Jeep Patriot with the Powertech 6F24 6spd automatic transmission, please note that it is no longer necessary to buy the oil pan service kit (68192621AA) to get the oil pan gasket.

The oil pan gasket has been made available individually via part number 68192622AA (please, always check STAR Parts for part number supersedence).

Please remember that this gasket is to be installed WITHOUT any type of sealer.

If you are replacing the gasket for a leak condition, please verify that the threaded case plugs above the oil pan rail are not the source of the leak, as there have been some unnecessary oil pan/gasket replacements due to this condition.

2015/2016 RT vehicles equipped with Keyless Go with Push Button Start

The RT is the last FCA vehicle with the “Push to Start Button” as an option. The “Push to Start” button is an independent component which is removable, and can be serviced independently for vehicles equipped with Keyless Go starting using the button.

The button is to be installed during dealer prep prior to customer delivery. It is supplied within its own packaging inside the Floor Mat Kit of the vehicle.

There have been warranty claims against this part for binding, sticking or popping off the Wireless Ignition Node (WIN), in which it is installed.

Parts returned for analysis have not shown or tested to be defective and have been validated to work correctly within other vehicles over extended-time-period testing.

Please ensure that the “Push to Start” button is installed correctly and functions without sticking, binding, or popping off prior to releasing the vehicle to the customer after purchase.

Your support in protecting the customer is greatly appreciated!



Pentastar Upgrade (PSU) engine

The 3.6L Pentastar Upgrade (PSU) engine was designed with a vision of providing our customers with fuel economy improvements of up to 6%, while improving low-end performance and maintaining refinement.

To accomplish this, 80% of the 3.6L PSU's components are all new, in comparison with the Pentastar "Classic" engine. In addition, the engine includes notable technology additions of 2-step variable intake valve lift (VVL) and cooled exhaust gas recirculation (EGR).

The 2-step VVL system allows the intake valves to open fully for optimized performance, or roughly half-way for optimized efficiency through reduced pumping losses. This creates unique OBD II diagnostics for the system performance.

The cooled EGR system passes a portion of the hot exhaust gas through a cross-flow cooler to reduce the temperature of the gas down to approximately 110 deg. C prior to flowing into the intake manifold. This allows for increased use of EGR in engine operation during times when high efficiency is required without adversely affecting engine knock. As with the 2-step VVL system, this new system for the PSU requires new diagnostics.

The PSU engine launched at Trenton North Engine Plant on 6/29/15 and will be first used in the 2016 WK and WD vehicles prior to replacing the Pentastar Classic in other applications.

The important thing to remember is that, although the PSU will immediately be recognizable as a member of the Pentastar family of engines, almost all key components and systems have been redesigned. Familiarity with Pentastar engines aside, it will be essential to verify part numbers and service procedures specific to the PSU as many of them are new or have been modified.

New TPM Sensors for 2016 Challengers, Chargers, and Chrysler 300's

Starting in December 2015, Dodge Challenger, Charger and Chrysler 300 tire pressure monitor (TPM) sensors will have a different look.

The old sensor, a Schrader WAL I model, is black. The new sensor, a Schrader WAL II, appears identical in shape to the WAL I but is colored gray to distinguish it from the old sensor.



New MY2016 production will use the new gray sensor and, as Mopar inventories are depleted, the gray sensor (68241067AB) should be ordered and used in place of the black sensor (56029398AB). Please, always refer to STAR PARTS to check for part supersedence. There is no change in installation procedures and the new sensor is interchangeable with the old sensor. Gray and black sensors can be mixed on the same vehicle. All four wheels do not need to use the same color sensor.

TPM Warning Lights in Cold Weather

It's no coincidence that you see an increase in TPM lamp complaints in cold weather.

"TPM" continued on next page



“TPM” continued from last page

Tires in cold weather deflate about 1 psi for every 11°F decrease in outside air temperature. It is very easy in northern climates for TPM systems to turn on the warning light when outdoor conditions reach freezing temperatures.

Usually your customers can easily remedy the problem by simply checking to see if the tire needs more air. The fix is to inflate the tire to the placard pressure listed on the driver’s door ‘B’ pillar. The vehicle may need to be driven for a few minutes above 15 mph for the TPM system to automatically read the new pressure.

A major advantage to Chrysler TPM systems on premium vehicles is the display on the cluster tells the driver which tire is low, and displays the pressure in all tires. Most of our competitors do not offer this feature.

Chrysler premium systems automatically localize TPM sensor ID’s, which means, no human intervention is required by the technician to program the location of TPM sensor ID’s into vehicle electronic control units after servicing. Please refer to the owner’s manual or service procedures for more information.

Some Bits and Pieces...

PF/UF Wheel Bolt (Lug) Information

Contrary to OLD service information, 2015 PF/UF wheel bolts (lugs) are reusable. The change to this info should be reflected in the service information in TechCONNECT.

MDS Solenoid Removal

After removing the MDS solenoid retaining bolt, **DO NOT PRY ON THE MDS SOLENOID TO REMOVE IT.** Instead, tap the top of the solenoid with rubber mallet, then rotate the solenoid back-and-forth to break the seal.

For more information, see MDS Solenoid Removal instructions located in the service information in TechCONNECT.

Electric Parking Brake (EPB) Actuator Operation During Battery Failure

For clarification, if the battery fails on a vehicle equipped with EPB, the EPB actuators will stay in the position they were in when power was lost. For example, if the EPB was not set (parking brake off) before battery failure, the EPB actuators will remain unapplied. If EPB was set (brake on), the actuators will remain applied. In this case, power would have to be restored to the actuators to release the parking brake.

KL/UF/PF Half Shaft Hub Nut Torque

When performing any service on KL/UF/PF vehicles that requires removal of the front half shaft hub nut, it is critical to follow the procedure as called out in the service information for the hub nut installation (DealerConnect/ TechConnect/ Service Info/ Front Suspension/ Front/Hub & Bearing/ Installation). Use a NEW hub nut and torque to 200 Nm (148 ft-lb). **NOTE: This is a higher torque than most other platforms.** Also follow the proper crimping procedure as described. Failure to do this will result in hub and/or bearing failure.

Brake Caliper Replacement Due to Appearance

Brake calipers should not be replaced due to the appearance of dampness on the assembly. The assembly lubricant used to install the piston and seals into the caliper often can leave residue which is sometimes mistaken as brake fluid. Brake fluid leakage will typically result in a bulge in the boot, excessive wetness of the caliper, and possible contamination of the brake pad. It will also result in reduced brake fluid level in the reservoir. Further inspection and verification should be performed before replacement.



RFI Causing Intermittent Concerns With RKE/Keyless Go Systems

Our field technicians have been experiencing intermittent problems, ranging from the RKE not working to the Keyless Go indicating “KEY HAS LEFT THE VEHICLE”, that are being caused by RFI from various charging and USB interface devices for portable electronics.

This can affect multiple year and models.

Examples of such devices are displayed below:



Depending on the system involved, these devices can generate a strong enough RFI signal in the various send and receive frequency bands.

Many of the vehicles have had numerous repair attempts made such as, SKREEM replaced, keys replaced, antenna(s) replaced, KIN replaced, RF HUB replaced, etc., without changing/fixing the complaint.

What makes these issues difficult to diagnose is that often customers take their chargers with them when they drop off the car. So the tech spends the time testing but never duplicates the concern.

The best practices to diagnose these issues successfully would be to either have the customer agree to charge everything at home and not plug anything into the vehicle for a week and see if the problem still happens, or, request that the customer have everything normally connected in the car and leave it for testing.

Your chances of identifying the cause of the customer’s concern should greatly increase.

Double Cardan Joint Maintenance

Since 2005 model year, 2500/3500 Ram 4X4 trucks have been using a double cardan universal joint on the front propeller driveshaft (pictured below).



“DRIVESHAFT” continued on next page



“DRIVESHAFT” continued from last page

As a reminder, these double cardan joints require lubrication periodically.

The assembly has a small grease fitting in the middle of the joint (Fig. 1).

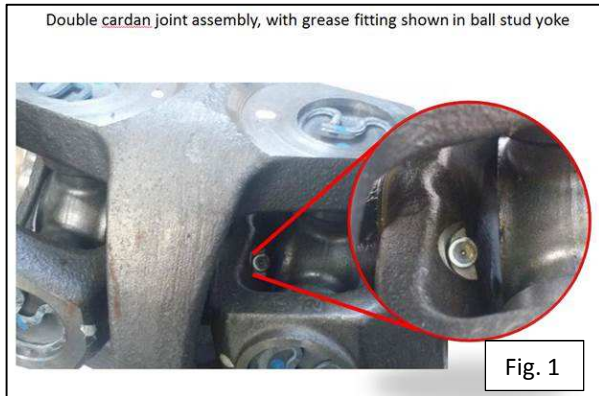

The fitting on the joint is not the typical Zerk fitting that is common on front suspension components.

The fitting is actually a conical depression in the joint that has a small steel check ball at the bottom.

The design and location of the fitting requires a special grease nozzle (Fig. 2) to access the lubrication point.

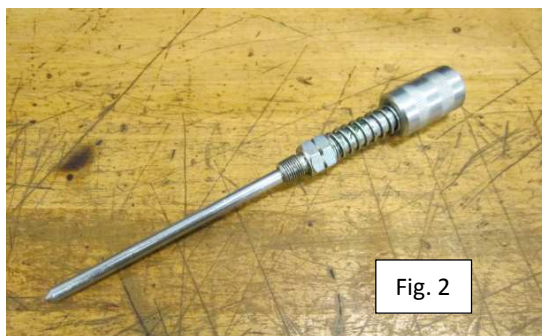

The Maintenance schedule in TechCONNECT and the Vehicle Owner’s Manual indicates lubrication at every oil change.

This has been the case since the 2005 Model Year.

There is also a Caution Label on the left front fender that reminds of the required maintenance and the type of grease that should be used (see below).



As pictured below, failure to lubricate this joint may lead to premature front propeller shaft joint wear and failure.



It is easy to see the evidence of a lack of proper maintenance after the joint has separated. Lack of grease in the cup area suggests that the joint was not maintained. Remember this failure and any collateral damage caused by it may not be considered warrantable failures.



MasterTech Updates

April 2015 MasterTech – Evaporative Emissions Systems

April's first lesson closely examines the components and operation of the evaporative system integrity monitor (ESIM) evaporative emissions (EVAP) system. The program covers the four leak classifications, key system components, and provides simple, animated views of the system during the various phases of operation. Since small EVAP leaks can be challenging to diagnose, the lesson closes with several tips and a small leak diagnostic example.

The ESIM system is mechanically simpler than previous EVAP monitoring systems, but functionally, ESIM is a little trickier to follow. The purpose of this lesson is to help technicians diagnose and repair ESIM systems more quickly and accurately.

Renegade/500X Radar Sensor Adjustment

The second lesson provides a quick look at the procedure and tools required to adjust the adaptive cruise control (ACC) module on the Jeep Renegade and Fiat 500X. (Please note that the ACC module is also called a "radar sensor" in some documents.) Currently, Renegades and 500Xs do not offer an ACC option, however the module is used for forward collision warning (FCW). Two special tools are required to align the module. The tools are only available from Mopar Essential Tools.

This lesson highlights the procedures for ordering and using the special tools.

Lesson 3 - Nine-Speed Transmission Update

In February's Master Tech, we provided an overview of the nine-speed transmission relearn procedures. April's last, brief lesson clarifies when technicians should apply the various nine-speed relearn procedures.

May 2015 MasterTech - Alignment Best Practices

May's Master Tech explains some best practices for dealing with customer complaints about off-center steering wheels and vehicles that lead or pull to one side or the other.

The program highlights two service bulletins that promote effective diagnostic and repair techniques to help eliminate wasted time and increase customer satisfaction by efficiently fixing off-center steering, or lead or pull issues, the first time.

The *May Tech News section* of the Master Tech reference book highlights three warranty bulletins. The first clarifies the reimbursement guidelines for machining engine parts. The second bulletin details the unique documentation required for reimbursement when using the ED-18 and GR-8 battery tester/chargers. The third bulletin explains two new failure codes for "flash only" procedures.

June 2015 MasterTech - DMM Features and Functions

Accurate electrical testing is often the key factor in producing an efficient, accurate diagnosis. And, except for a scan tool, a digital multimeter (or DMM) is probably the most useful tool available for electrical diagnosis. Therefore, June's Master Tech includes a look at various DMMs' features and functions, and tips on using a DMM to diagnose some common electrical issues.

"MASTERTECH" continued on next page



“MASTERTECH” continued from last page

International Special Tools

Technicians may have noticed that some unique tools for the Jeep Renegade and Fiat 500X (as specified in Service Information) are unavailable from the Mopar Essential Tool website. The brief, second feature explores technicians’ options for substituting or acquiring the special tools.

Labor Operations Efficiency

June’s Tech News explains why efficiency is tracked and how efficiency is calculated. The section clarifies Warranty Administration’s policy on reported efficiency and possible adjustments, defines shop and individual efficiency calculations, and explains efficiency targets.

July 2015 MasterTech – Data Recording For STAR

This lesson briefly covers using the new wiTECH 2.0 scan tool to create Vehicle Scan Reports, Configuration Reports, and flight recordings. STAR Center agents often require vehicle reports to help technicians develop an accurate diagnosis.

New STAR Assistance Request

For the past few years, the Request Technical Assistance button on the TechCONNECT home page has been the preferred method to open a STAR case in most situations. STAR is introducing an upgraded version of the request in the third quarter of 2015.

The purpose of this lesson is to highlight new features of the updated process, explain the key benefits of the new features, and point out a couple of restrictions added to the process.

LOP Time Studies

In this lesson, we look at how time studies, for labor operations (or LOPs), are completed; and hopefully, clear up some common misconceptions.

Parts Returns

July’s Tech News explains the importance of returning the correct parts with matching documentation to the Quality Return Center, along with properly packaging failed parts for return.

August 2015 MasterTech – Wrangler Water Leak Test Tips and Techniques

Diagnosing and repairing JK Wrangler water leaks can be a frustrating assignment without the proper tools and a clear understanding of the top’s water management system.

This Master Tech is not designed to be a comprehensive training program on every aspect of Wrangler top seals. However, we will look at:

- Wrangler’s various top components
- Examples of effective (and ineffective) water leak test devices.
- The tops’ system of seals, dams, and drains.
- The recent availability of some new, more comprehensive service procedures
- Seal replacement tips.

New Autopay Function

August’s Tech News covers the new Autopay Function for wiADVISOR and some of the details of the new process.

September 2015 MasterTech – Diesel Exhaust Fluid System Tips

A properly operating diesel after treatment system is required to meet various emissions regulations. FCA employs a selective catalytic reduction (SCR) system to reduce oxides of nitrogen (NOx). For proper operation, the SCR system requires an ample supply of high-quality diesel exhaust fluid (DEF).

“MASTERTECH” continued on next page



“MASTERTECH” continued from last page

This month’s Master Tech concentrates on explaining the SCR system, and some associated faults that cause diagnostic trouble codes (DTCs), because:

- Some after treatment-related DTCs can prevent the vehicle from starting or from running at full power, which generally gets our customers’ full attention.
- SCR diagnostic trouble codes can be difficult to diagnose without a reasonable understanding of the system.

Transmission Oil Cooler Service

This article covers some new guidelines regarding transmission oil cooler flushing and replacement.

October 2015 MasterTech – Power Windows, Powered Probes and Test Lights

This month’s MasterTech touches on tips regarding usage of powered probes and test lamps, the advantages and disadvantages of each and when to use them efficiently.

In the Power Window Highlights lesson, we cover the control methods and basic diagnostics for four different systems on two different vehicles

Recall Procedures and Remanufactured Parts

In October’s Tech News section, we discuss recall procedures and why it’s important to closely follow the procedures as written in recall documents.

We also discuss the subject of remanufactured parts and when they should be used.

November 2015 MasterTech – Pentastar V6 Upgrade Highlights and MasterTech Updates

The Pentastar V-6 engine is undergoing a major upgrade for the 2016 Grand Cherokee and Dodge Durango.

The new engine looks quite a bit like the current Pentastar, but nearly every component is redesigned and assigned a new part number.

Master Tech reviews the key changes, including engine stop/start (ESS), that allow the upgraded Pentastar to produce up to 14% more torque, with about 6% better fuel economy, and no added weight.

Also discussed are next month’s coming changes to the MasterTech Updates.

Various Vehicle Issues Occurring After Tint Applied to Windshield

There have been multiple reports from the field involving customer complaints on 15 WK and L-body vehicles occurring after the application of window tinting to the windshield. Complaints include MIL-on, difficulty starting, vehicles will not turn off, inoperative horns, turn signals, interior/exterior lights, etc.

The cause of most of these failures has been traced to corrosion inside the BCM due fluid contamination caused by improper application methods during the windshield tinting process.

The process of applying tinting to the windshield requires a large amount of cleaning solution to be sprayed on the interior of the windshield prior to application of the window tint foil. A squeegee is then used to remove the solution between the windshield and the window tint foil. If proper precautions are not taken, like placing a towel at the base of the windshield to catch and absorb the excess fluid, the excess fluid will drip down between the instrument panel and the windshield and land on the BCM. Over time the excess fluid will enter the BCM and cause corrosion of the printed circuit board assembly and electrical components, and, eventually cause symptoms as described above.



Various Issues Due to Improper Latching of PDC Cover After Service

There have been reports of various customer complaints caused by water intrusion into the TIPM (Totally Integrated Power Module) on 15 JK and RT models after the TIPM cover was removed for some related service. The cause of the water intrusion into the TIPM is the failure to ensure proper closure and latching of the TIPM cover after servicing.

Please ensure the TIPM cover is properly closed and latched if it is necessary to remove the cover during a service procedure.

New LOP 85-41-25-02 “No Repair / Trouble Not Found Diesel Exhaust Fluid”

You might remember that a few years ago several new no repair / trouble not found LOPs were introduced. Those have been expanded to include an option for diesel exhaust fluid (DEF) systems. Using this new LOP will report issues to the Engine Systems quality group. In the past many of these concerns were being reported as Powertrain Systems (group 09). This new LOP option will help FCA further understand what concerns the customers are reporting to the dealers. The best way to select the correct LOP is to make sure your technician’s notes have details about what vehicle system they inspected, what they did or did not find, and what test they performed along with the results from the test they completed. Keep in mind, the LOP used on the claim is used to identify which system was inspected, which is why we want to make sure you are aware of the additional reporting area.

Other New LOPs

New LOPs:

- **854110** - Engine Driveability (replaces 854118)
- **854117** -Driveline/PTU/Transfer Case Electrical
- **854120** -Transmission Mechanical

See DealerCONNECT for more information.



ESSENTIAL TOOLS AND SERVICE EQUIPMENT

ARE YOU READY FOR A/C SEASON?

**ROB22791
Infrared Refrigerant Leak Detector**

Features:

- Advanced infrared sensor is designed to last a minimum of 10 years.
- Three sensitivity levels down to 0.15 oz./year.
- Automatically recalibrates in highly contaminated areas to help pinpoint the exact location of the leak.
- Senses CFC, HFC, HCFC blends and HFO-1234yf refrigerants.
- 8 hour lithium ion battery lasts all day long and beyond.
- Visual alert and peak button make it easy to find leaks in noisy environments.
- Audible alert with mute button.
- Magnetic hanger to easily hang the unit during leak repair.
- Durable carrying case lets you easily store leak detector and accessories.
- Meets new SAE J2913 standard for R-1234yf and previous SAE J2791 standard for R-134a.



Visit
MoparEssentialTools.com
for Pricing!

**AIR62644
Ulti-Flex Pressure Spray Tool™**

OEM-Approved Precision Atomizing Tip Assures Optimal Product Diffusion.

Features:

- Ulti-Flex Pressure Spray Tool™ The Best way to apply Cooling Coil Cleaner (05170022AA) and Cooling Coil Coating (0478942AB) or any automotive fluid.
- Bend to fit any underhood or undercar configuration.
- Use with shop air for fast application or powerful cleaning action.
- Durable metal construction, protective sheathing.



Visit **MoparEssentialTools.com** for Tools and Equipment for All Your A/C Needs.
Call 1-855-298-2687 • **MoparEssentialTools.com**

AUTHENTIC PERFORMANCE



billiard lamp
A72699942N
\$495.95

We have been working all year to bring you the ultimate gifts for holiday.
It's never too soon to start making your list!

knit hat
A72779942N
\$16.95

knit hat
A72782542N
\$20.95

drag pak
tech jacket
A72791342
\$149.95

neoprene
tablet sleeve
A72592842N
\$12.95

license plate
ornament
A72912842N
\$35.95

WEARMOPAR.COM

AUTHENTIC PERFORMANCE



Remember, when all else fails, go back to the basics...and by the way, here's the basics!

SIX-STEP TROUBLESHOOTING PROCEDURE

Step One: Verify customer complaint

- DO NOT attempt repairs without first verifying.
- The R.O. must contain all essential information about the complaint.
- Unfavorable arbitration and lemon law rulings have resulted due to an unnecessary number of attempted repairs without verification of problem.
- An exception would be when a SB matches an owner complaint exactly.
- Never proceed any further if the customer is complaining about a design characteristic of the vehicle. That must be dealt with carefully.

Step Two: Determine related symptoms

- Check other systems on the vehicle that are or could be affected. Two systems were on the same circuit on some older models.

Step Three: Analyze the symptoms

- What could cause the problem? For example, could it be a wire routing or terminal issue, not an open or a bad/poor ground?
- In this step knowledge, experience and application of training are utilized.
- Always ensure the best qualified technician is performing the current repair.

Step Four: Isolate the trouble

- With a water leak, for example, it is vital that all possible sources of leaking are found.
- This also pertains to "repairing only the affected areas," and not over-repairing.

Step Five: Repair the trouble

- Do the repairs as appropriate. Follow the service manual instructions or when performing a SB, follow it very specifically.

Step Six: Verify proper operation

- This means that if a lengthy test drive is necessary, it must be done.
- This is the most important step before the vehicle is returned to the customer.
- If this step is omitted, customer satisfaction will be affected due to the customer returning if the vehicle is not right. This is wasteful of everyone's time. That affects the customer, the service advisor, the technician and the service manager.

STAR Center Areas of Responsibility



Engine/Climate control Group
Component Codes 07, 09, 24

- Internal engine components
- Accessory drive system components
- Radiator, Hoses, Cooling system components and sensors
- A/C or heater components or controllers including blower motors

Transmission Group
Component Codes 03, 06, 21

- Manual and Automatic Transmissions
- Clutch systems
- Transfer case
- Drive axles
- Propeller shaft
- Transmission cooler & lines
- Axle assemblies

Driveability/OBDII Group
Component Codes 11, 14, 18, 25

- Engine performance including MIL illumination, OBDII monitors and C.A.R.B. readiness monitors
- Throttle body, throttle linkage, fuel injectors, and spark plugs
- Exhaust system
- Fuel delivery system, fuel tank, lines and hoses
- Air cleaner assembly
- Cruise control
- Emission controls, Engine controller, sensors and relays related to the fuel system
- Data recording review, Copilot, DRB and STARSCAN software update procedures
- Flashing concerns related to PCM/ECM/TCM.

Body/Chassis Group
Component Codes 02, 05, 10, 13, 17, 19, 22, 23

- ABS and Base brake systems
- Wheels and tires
- Steering
- Suspension and frames
- Sheet metal, Body sealing, glass, sunroof
- Interior components and systems
- Moldings, bumpers, exterior lights and convertible tops
- Paint and metal finish

Audio/Video/Navigation/Telematics Group
Component Code 8A

- Radio, clocks and entertainment systems

Electrical Group
Component Code 08

- Instrument panel and cluster
- Body wiring and lighting
- Fuel sending units and level reading issues
- Passive restraint systems
- SKIM, Theft alarm, and remote keyless entry concerns
- Alternator, battery, starter, relays
- Body controllers and other modules, except PCM/TCM
- Module flashing concerns related to all modules EXCEPT PCM/ECM/TCM.

STAR News Feedback

STARNEWS@FCAGROUP.COM



Contacting STAR for Assistance Tips

Have the Ticket number, tests performed and results with you when calling for assistance.

Concerns that cannot be duplicated

Without being able to duplicate the customer's concern and gathering certain data, there is typically very little technical assistance that can be provided. A call to the STAR Center may be a wasted effort. We recommend the following be performed before calling:

- 1) Review warranty history
- 2) Review any previous repair attempts on same complaint
- 3) Review Quick Hits for similar issues
- 4) Perform 6 Step Diagnostics
- 5) Make sure customer process is documented
- 6) Ask additional questions to the customer
- 7) Install vehicle data recorder
- 8) Drive vehicle and try to duplicate
- 9) Wait for reoccurrence

Diagnostics not performed

Please complete basic diagnostics prior to calling, including the 6 Step Diagnostics. The STAR center should be utilized for concerns that required high level technical assistance.

Information already available

Please utilize search functions, such as TechConnect and the search feature in Tech Connect called Quick Hits. You will be asked upon calling the STAR Center if you have completed this search which provides STAR Online, SB's, Recalls, RRT's and Tech Tips (GPOP) along with service and wiring information.

The caller is not the Tech working on the vehicle

The person working directly on the vehicle should be calling so that proper technical assistance can be provided. Time is wasted when all details of the issue and work already completed is not readily available.

Vehicle is not at the dealership

Do not call if the vehicle is not at the dealership. Calling to try and get information prior to seeing the vehicle or doing a complete diagnosis is a misuse of the STAR Center Agents and extends the hold time for other technicians requiring assistance.

***Please pass the word to all the Service Technicians at your Dealership. Thank you! ***





IVR PHONE SYSTEM OVERVIEW

Beginning September 23, 2010, the STAR Center launched an enhancement to the current IVR process. The intent of the new process is to improve technician access to STAR. This is accomplished by requiring a 'Request for Technical Assistance' be completed in TechCONNECT prior to contacting STAR. Requests for assistance will generate Ticket numbers the technician must then use to call STAR. Please keep in mind that requests made by technicians with training levels 1 and 2 for that specific problem will only be able to receive an e-mail response to that specific request. If you call STAR with a ticket number that is not authorized, the IVR will direct you back to TechCONNECT to review your e-mail response.

Service Managers will be able to call STAR after creating a ticket using their Sid regardless of training levels.

A few helpful hints to consider when calling in for assistance:

- It will be helpful to call from a less noisy location than the shop floor. Try to find a location where there is less noise or other conversations in the immediate area. We anticipate that this will improve your calling experience and interaction with the new IVR system.
- Ensure that the phone that you are calling from is in good working condition and is free of excessive static or noise. It is also recommended that you do not use the hand free option or a headset/amplifier setup when placing you call.
- If you know your option, you do not have to wait for the entire message to play before speaking your choice. You are encouraged to "Barge In" with your selection.

After the initial welcome message, you will be presented with 3 choices:

1. Enter your Technical Assistance ticket number
 2. Say "Mopar Accessories"
 3. Say "Part or Labor Op Restriction"
- If you enter a valid ticket number, your call will be routed to the correct group of the Star Center.
 - If you requested "Mopar Accessories", your call will be transferred to the Mopar Accessories group.
 - If you entered "Part of Labor Op Restriction" you will be prompted for:
 1. S-ID
 2. Vin
 3. Part Number

Items to keep in mind:

- Speak your responses in a normal tone of voice. You do not have to yell or place special emphasis on the numbers or letters. If you have problems speaking the information, you can use the keypad on your phone to enter it.
- The two digit component group is the area in the service manual that you would expect to find the diagnostic information (e.g., Group 14 is Fuel, Group 8 is Electrical, Group 25 is Emissions).

***NOTE* If you default to manual input using the key pad, you will need to complete the remainder of the inputs using the keypad only. The voice recognition software will assume that you are in a noisy environment and will disregard any additional voice inputs.**