

# OCCUPANT DETECTION SYSTEM (DIAGNOSTICS) > Diagnostic Procedure with Diagnostic Trouble Code (DTC)

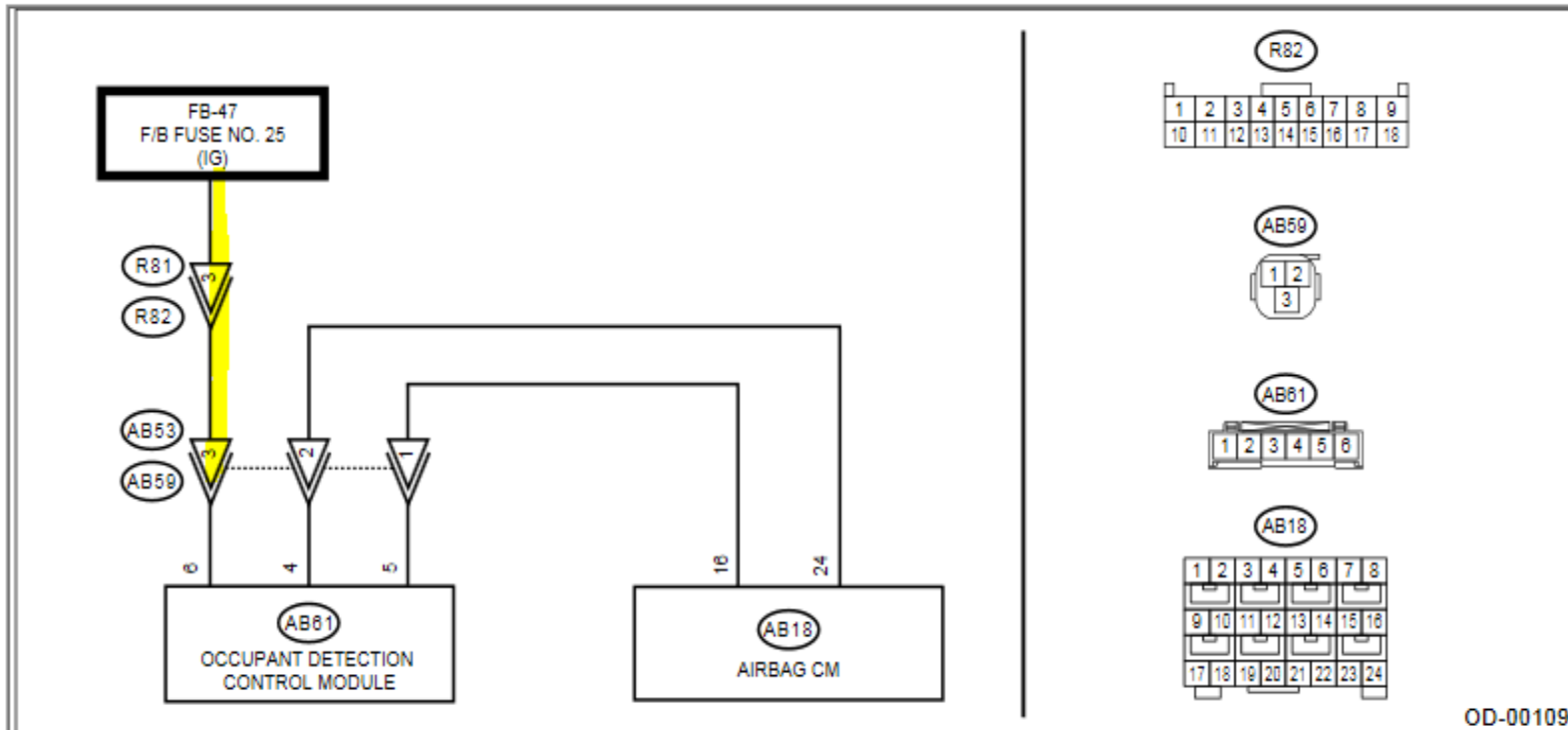

OD-00109

**Zero voltage at Connector AB53 Pin No. 3**

WIRING SYSTEM > Occupant Detection System

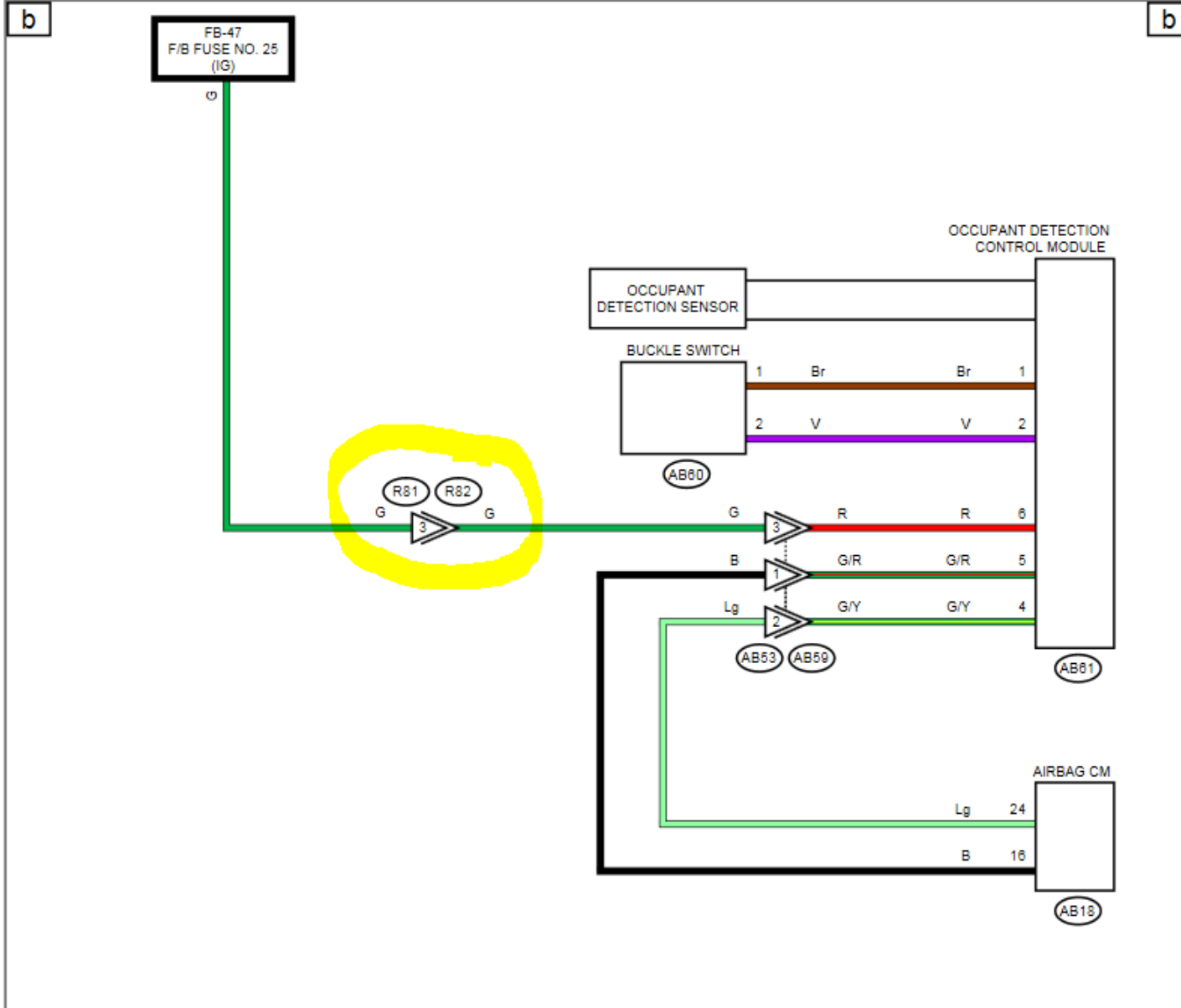

Zero voltage at Connector R81 Pin No.3

Fuse No. 25 supply power to the ODS and the Air Bag control modules had 12.14v at each side of fuse. The Green wire at Connector AB35 Pin # 2 at the fuse panel had backed out of the connector.

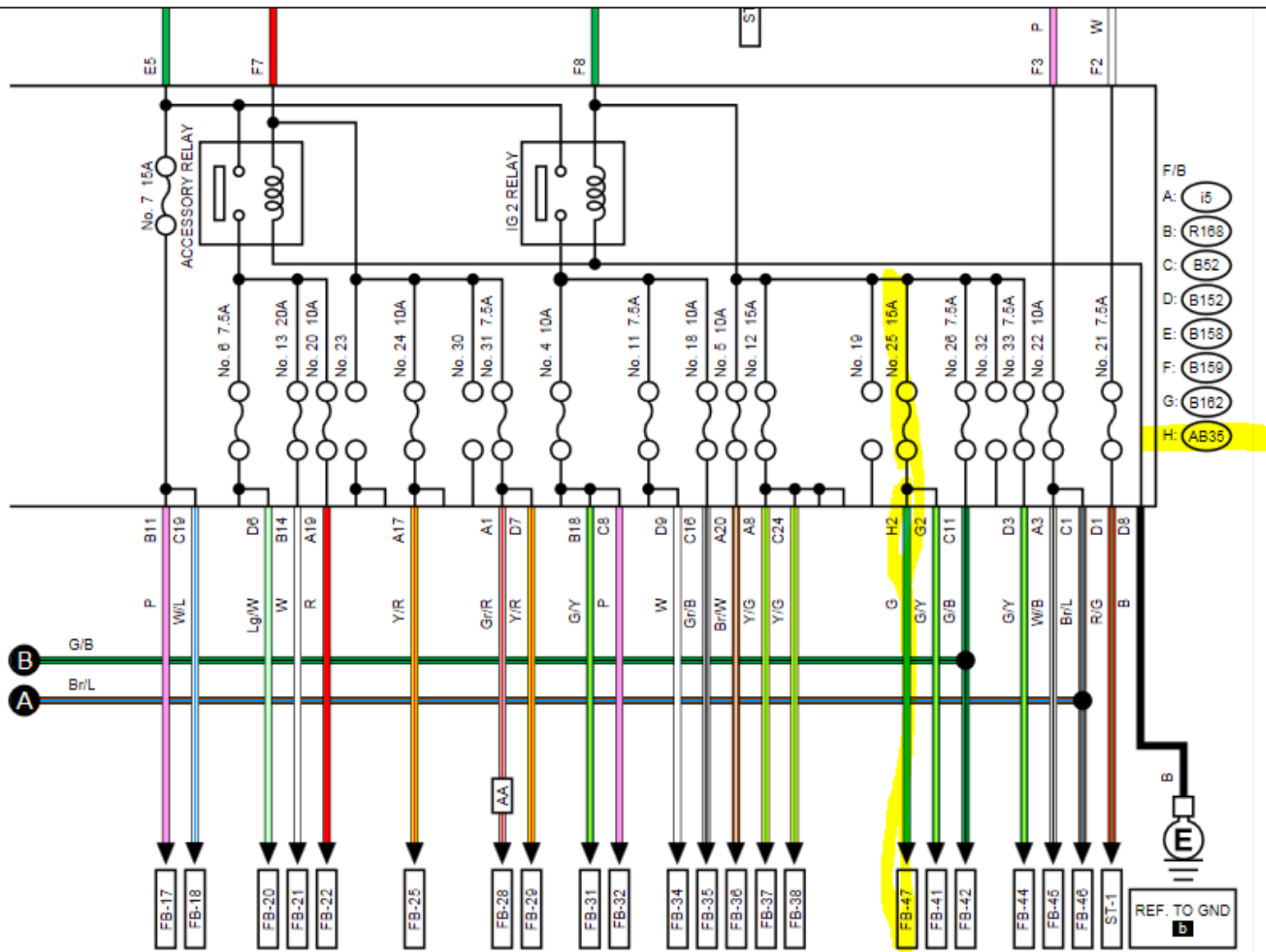

AA : AUTO A/C