

PE18-012

GM

3-27-2019

Q3

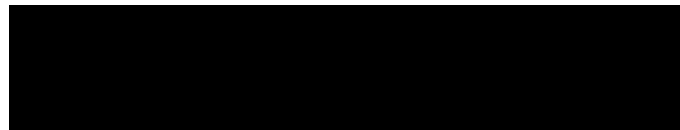

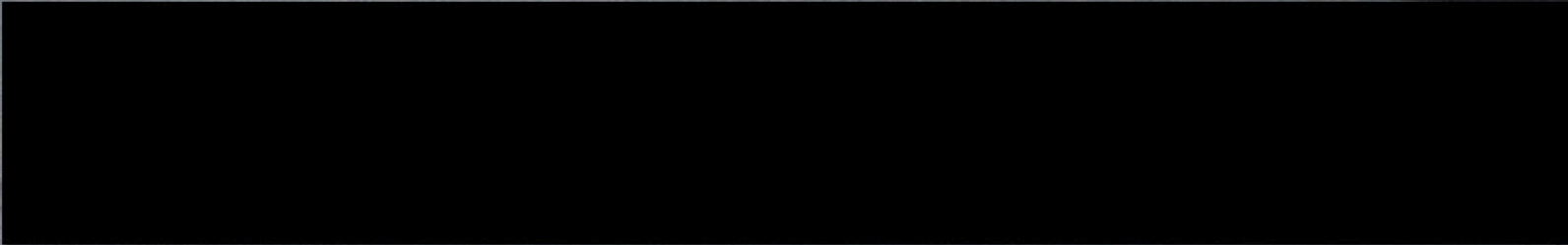

REGISTRATION CARD VALID FROM: 12/31/2017 TO: 12/31/2018

MAKE	YR MODEL	YR 1ST SOLD	VLF CLASS	*YR	TYPE VEH	TYPE LIC	LICENSE INDEX
CHEV	2016	2015	PL	2016	32X	31	[REDACTED]
BODY TYPE MODEL	MP	MO	AX	WC	UNLADEN/G/CGW	VEHICLE ID NUMBER	
LM	G	ZP	2	E	05420	1GNSCHKC3GR [REDACTED]	
TYPE VEHICLE USE		DATE ISSUED	CC/ALCO	DT FEE RECVD	PIC	STICKER ISSUED	
COMMERCIAL		03/27/18	19	03/27/18	8	[REDACTED]	
		PR/HIST: TAXI				PR EXP DATE: 12/31/2017	



AMOUNT PAID
\$ 869.00

AMOUNT DUE	AMOUNT RECVD
\$ 869.00	CASH : 760.00
	CHCK : 109.00
	CRDT :

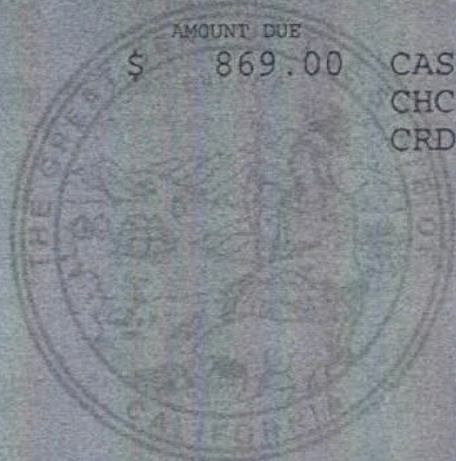

LIENHOLDER
ALLY FNCL
PO BX 8128

COCKEYSVILLE
MD

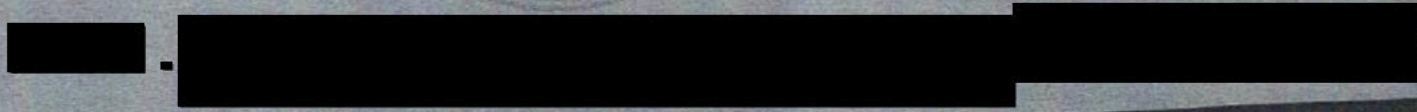

PE18-012

GM

3-27-2019

Q3

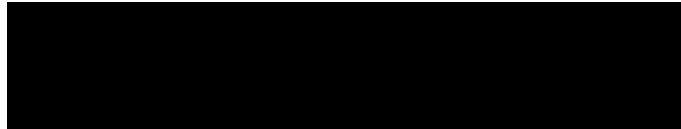



March 16, 2018

Mary Arens, Esq.
Erskine Law Group
26056 Acero
Mission Viejo, CA 92691

RE: [REDACTED] v. General Motors
Service Request [REDACTED]
GM Legal Staff Case: [REDACTED]
2016 Chevrolet Suburban
Vehicle Identification Number: 1GNSCHKC3GR [REDACTED]
Customer Relationship Specialist: Jeralyn

Dear Ms. Arens:

Enclosed is a copy of our file regarding the above referenced case. It is being removed from the Early Resolution Program and turned over to you for further handling. Please see the "Reason for Removal" section of the "Case Assessment" form.

In case you need to contact the designated Field Representative, their information is listed below.

Paul Wasko
P: 805-217-2835
E: paul.wasko@gm.com

Paul Byrne
P: 805-279-8324
E: paul.byrne@gm.com

If you have further questions, please contact our Business Resource Center at 1-800-231-1841 Monday through Friday between 8:00 a.m. and 5:00 p.m., Eastern Time. Please refer to the service request number above and a Customer Relationship Specialist will be happy to assist you.

Sincerely,

General Motors

PE18-012

GM

3-27-2019

Q3

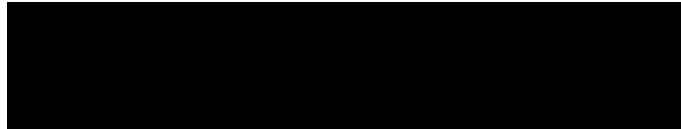

Jeralyn Vara (C)

From: Jeralyn Vara (C)
Sent: Friday, March 16, 2018 10:31 AM
To: Robert M. Kropp
Cc: Valentino R Farias (C); Nora Valverde (C) (nora.valverde@gm.com)
Subject: BRC Legal Lawsuit [REDACTED] v. General Motors Company

[REDACTED] v. General Motors Company

Service Request: [REDACTED]
Vehicle: 2016 Chevrolet Suburban
Vehicle Identification Number: 1GNSCHKC3GR [REDACTED]

Dear Mr. Kropp,

The above Chevrolet customer has filed an ER lawsuit and the lawsuit is being removed from the Early Resolution Program and being sent to General Motors' local counsel for handling. Our records indicate Paul Wasko and Paul Byrne were contacted while the case was in the Early Resolution Program. The customer has been to the following dealers for servicing thus far:

Servicing Dealership:

Camino Real Chevrolet

BAC: 114 [REDACTED]

A: 2401 S Atlantic Blvd Monterrey Park CA 91754

P: 323-264-3050

Keyes Chevrolet

BAC: 259 [REDACTED]

A: 5949 N Van Nuys Blvd Van Nuys CA 91401

P: 818-267-1400

GM's attorney now handling this case:

Erskine Law Group

Mary Arens, Esq.

marens@erskinelaw.com

26056 Acero Mission Viejo, CA 926691

P: (949) 777-6032

F: (248) 601-4497

GM Legal Assistant involved:

Rocky Farias

rocky.farias@gm.com

(512)-389-7057

Customer's attorney now handling the case:

California Lemon Law Center, Inc.

PC: Lucy Kasparian ESq

P#: 818-547-5777

F#: 818-547-9777

E: info@cllclaw.com

A: 535 West Glenoaks blvd Glendale CS 91202

Please have the designated Field Representative(s) notify the dealership(s) listed above and any other dealers in the vicinity of the customer's address that this customer has filed an ER lawsuit against General Motors. Please have them tell the dealer(s) to make sure that any necessary, future repair work is thoroughly documented. The Field Representative(s)/dealership(s) should direct any documentation, repair orders and any other information particular about this customer and his/her vehicle to General Motors' attorney.

Attaching the case assessment for review. If you have further questions, please contact our Business Resource Center at 1-800-231-1841 Monday through Friday between 8:00 a.m. and 5:00 p.m. Eastern Time. Please refer to the service request number above and an Advisor will be happy to assist.

Thank you for your assistance.

Sincerely,

Chevrolet

PE18-012

GM

3-27-2019

Q3

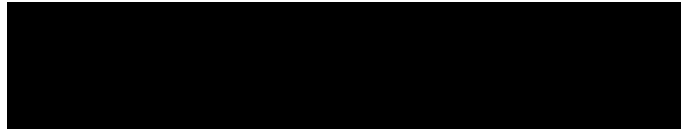

Luz Solorzano-Ortiz (C)

From: Luz Solorzano-Ortiz (C)
Sent: Friday, March 02, 2018 4:14 PM
To: 'garias@caminorealchevrolet.com'
Subject: Request for Documentation [REDACTED]

Customer Name [REDACTED]
VIN#: 2GNALFEK6C [REDACTED]
Y,M,M: 2012 Chevrolet Equinox

Guadalupe,
I wanted to follow up with you on the request for documents for customer with last 8 of the VIN K60 [REDACTED]. I know I have requested documents for another client so I wanted to make sure I did not confuse you. If you could attach all ROs, sales, after market and accident modification documentation, I would really appreciate it.

Thank you

Luz Solorzano-Ortiz
Business Resource Center
Alorica on Behalf of General Motors
Phone: (866) 790-5700, ext. 5924208

PE18-012

GM

3-27-2019

Q3

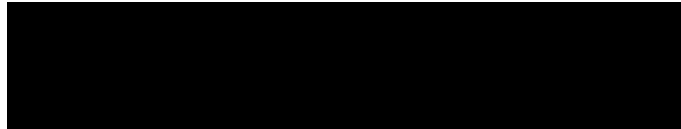

Luz Solorzano-Ortiz (C)

From: Luz Solorzano-Ortiz (C)
Sent: Thursday, March 08, 2018 11:08 AM
To: 'ediaz@keyschevy.com'
Subject: Request for documentation [REDACTED]

Hello Eduardo,

Please reply to this email with the documentation requested.

Thank you
Luz Solorzano-Ortiz
Business Resource Center
Alorica on Behalf of General Motors
Phone: (866) 790-5700, ext. 5924208

PE18-012

GM

3-27-2019

Q3

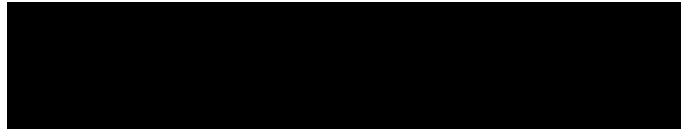

Document ID: 4981317

#16007-04: Safety Recall - Frontal Airbag and Pretensioner Non Deploy - (Feb 21, 2018)

Subject: 16007-04 — Frontal Airbag and Pretensioner Non Deploy

Models: 2014–2017 Buick Encore
 2014–2016 Buick LaCrosse
 2015–2017 Cadillac Escalade, Escalade ESV
 2014–2017 Chevrolet Caprice, Corvette, Silverado, Trax
 2014–2016 Chevrolet Spark EV, SS
 2015–2017 Chevrolet Suburban, Tahoe
 2014–2017 GMC Sierra
 2015–2017 GMC Yukon, Yukon XL



Reference Number: [REDACTED]	Release Date: February 2018
Revision: 04	
Revision Description: This bulletin is being revised to remove the screenshot attachment requirement in the Service Procedure and Warranty Information sections. Please discard all previous copies of bulletin 16007-03	

Attention:	<p>It is a violation of Federal law for a dealer to deliver a new motor vehicle or any new or used item of motor vehicle equipment (including a tire) covered by this notification under a sale or lease until the defect or noncompliance is remedied.</p> <p>All involved vehicles that are in dealer inventory must be held and not delivered to customers, dealer traded, or used for demonstration purposes until the repair contained in this bulletin has been performed on the vehicle.</p>
-------------------	---

Make	Model	Model Year		RPO	Description
		From	To		
Buick	Encore	2014	2017		

Buick	LaCrosse	2014	2016		
Cadillac	Escalade	2015	2017		
Cadillac	Escalade ESV	2015	2017		
Chevrolet	Caprice	2014	2017		
Chevrolet	Corvette	2014	2017		
Chevrolet	Silverado	2014	2017		
Chevrolet	Spark EV	2014	2016		
Chevrolet	SS	2014	2016		
Chevrolet	Suburban	2015	2017		
Chevrolet	Tahoe	2015	2017		
Chevrolet	Trax	2014	2017		
GMC	Sierra	2014	2017		
GMC	Yukon	2015	2017		
GMC	Yukon XL	2015	2017		

Involved vehicles are marked "open" on the Investigate Vehicle History screen in GM Global Warranty Management system. This site should always be checked to confirm vehicle involvement prior to beginning any required inspections and/or repairs.

Condition	<p>General Motors has decided that a defect which relates to motor vehicle safety exists in certain 2014-2017 model year Chevrolet Silverado LD, GMC Sierra LD, Buick Encore, Chevrolet Trax, Chevrolet Caprice Police, and Chevrolet Corvette vehicles, 2014-2016 model year Buick Lacrosse, Chevrolet Spark EV, and Chevrolet SS vehicles and 2015-2017 model year Chevrolet Silverado HD, GMC Sierra HD, GMC Yukon, GMC Yukon XL, Cadillac Escalade Cadillac Escalade ESV, Chevrolet Suburban, and Chevrolet Tahoe vehicles. The sensing and diagnostic module (SDM) in these vehicles, which controls airbag and pretensioner deployment, contains a software defect which may prevent the deployment of frontal airbags and pretensioners in certain rare circumstances. If the frontal airbags and seatbelt</p> <p>© 2018 General Motors. All rights reserved.</p>
------------------	--

	pretensioners do not deploy when required, there is an increased risk of injury to occupants in a crash.
Correction	Reprogram the SDM with new software that eliminates this defect. In vehicles with any previous deployment events recorded in the SDM, the dealers will replace the existing SDM with a new SDM containing the latest software.

Parts Information

Note: If a replacement is required, use the VIN and the GM Electronic Parts Catalog (EPC) to determine which SDM to order. It is estimated that only 1% of involved vehicles will require SDM replacement. Due to limited initial parts availability, dealers are encouraged not to order recall parts for use as shelf stock.

Warranty Information

Labor Operation	Description	Labor Time	Trans. Type	Net Item
	Reprogram Inflatable Restraint Sensing and Diagnostic Module Calibrations	0.3	ZFAT	N/A
	Replace Airbag Sensing and Diagnostic Module (Includes Programming)	**	ZFAT	N/A
	Customer Reimbursement Approved	0.2	ZFAT	***
	Customer Reimbursement Denied – For USA dealers only	0.1	ZFAT	N/A

Note: To avoid having to “H” route the customer reimbursement for approval, it must be submitted prior to the repair transaction.

* To avoid warranty transaction rejections, the SPS Warranty Claim Code must be entered into the GWM system when submitting this transaction.

** Refer to *Airbag Sensing and Diagnostic Module Replacement* in the LTG for the appropriate labor time on the make and model being repaired.

*** The amount identified in “Net Item” should represent the dollar amount reimbursed to the customer.

Service Procedure

Note: Carefully read and follow the instructions below.

- Ensure the programming tool is equipped with the latest software and is securely connected to the data link connector. If there is an interruption during programming, programming failure or control module damage may occur.
- Stable battery voltage is critical during programming. Any fluctuation, spiking, over voltage or loss of voltage will interrupt programming. When required install the *EL-49642* SPS Programming Support Tool to maintain system voltage. If not available, connect a fully charged 12V jumper or booster pack disconnected from the AC voltage supply. DO NOT connect a battery charger.
- Turn OFF or disable systems that may put a load on the vehicles battery such as; interior lights, exterior lights (including daytime running lights), HVAC, radio, etc.
- Clear DTCs after programming is complete. Clearing powertrain DTCs will set the Inspection/Maintenance (I/M) system status indicators to NO.

Programming SDM

Note: If programming fails, before contacting TCSC, refer to the "Unable to Program SDM" section below to note the value of the parameter name "Software Module 1 Identifier" and "Software Module 2 Identifier".

Pre-SPS Programming Tips

- Verify the vehicle is not in "Transport Mode" before beginning programming.
 - Record and clear all DTC's in the vehicle before reprogramming the SDM.
1. Access the Service Programming System (SPS) and follow the on-screen instructions.
 2. On the SPS Supported Controllers screen, select K36 Inflatable Restraint Sensing and Diagnostic Module - Programming and Setup and follow the on-screen instructions.

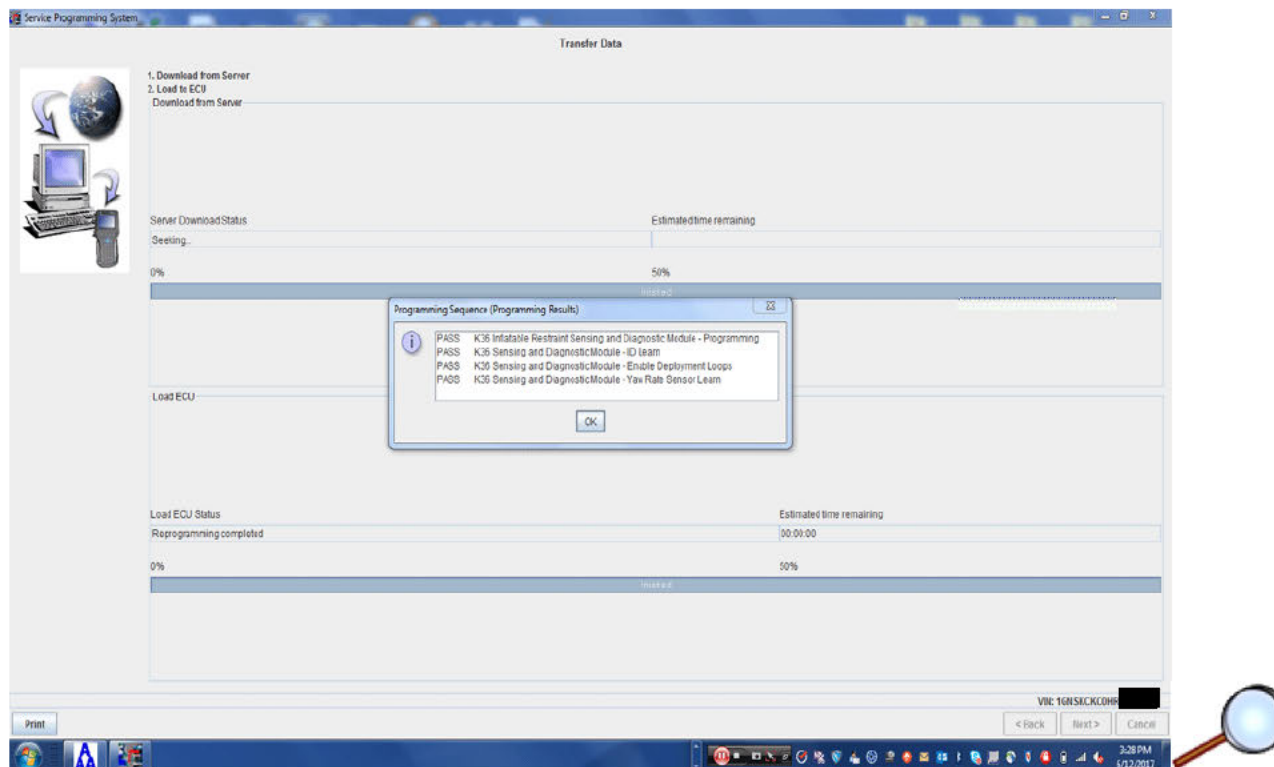

2.1. To avoid warranty transaction rejections, the SPS Warranty Claim Code must be entered into the GWM system when submitting this transaction.

Important: The screen above should show all "PASS" or "SKIPPED" and/or "PASS" if the programming event is successful. If ANY of the results show "FAILED", proceed to "Unable to Program SDM" section.

3. Record SPS Warranty Claim Code on job card for warranty transaction submission.
4. At the end of programming, choose the "Clear All DTCs" function on the SPS screen.
 - If the SDM programming fails, refer to Unable to Program SDM.

Unable to Program SDM

SPS Programming Tips

- If there is a deployment loop failure, please make sure the ignition switch is in the "Run" position, not the Accessory position. This typically occurs with push button Start. To verify the ignition switch is in the "Run" position go into GDS2, select the ECM and check for ignition 1 voltage. If it is at 12+ volts the ignition switch is in the correct position.
- If a Buick Encore displays an E-4491 programming failure, please check that the vehicle was built in TIS2Web as a light duty truck, not a passenger car.

- Using the GDS2 scan tool, build the vehicle and proceed to the Identification Information screen using the following path: Module Diagnostics>Inflatable Restraint Sensing and Diagnostic Module > Identification Information.

Parameter Name	Value
Vehicle Identification Number (VIN)	1GKS2BKCYGR [REDACTED]
End Model Part Number	13694413
Base Model Part Number	13690221
Manufacturer's Traceability Number	[REDACTED]
Inflatable Restraint Sensing and Diagnostic Module Primary Key	9721
Software Part Number	13516038
Calibration Part Number 1	84219721
Calibration Part Number 2	23207234
Diagnostic Data Identifier	0B11
Software Module 1 Identifier	0 Counts
Software Module 2 Identifier	0 Counts
High Voltage Disable Requested - Crash Event Detected	No
Transmitting Acceleration Sensor Reading on Bus	Enabled



Note: "Software Module 1 Identifier" and "Software Module 2 Identifier" provides deployment or near-deployment event information.

- Note the value for parameter name "Software Module 1 Identifier" and "Software Module 2 Identifier".
 - If the value is greater than 0 for either of these parameters, replace the SDM. Refer to *Airbag Sensing and Diagnostic Module Replacement* in SI. Print the Identification Information screen and retain it with the Repair Order (RO).
 - If the value for these parameters is 0, attempt to continue programming one more time before contacting the Techline Customer Support Center (TCSC) at 1-800-828-6860 (English) or 1-800-503-3222 (French). Refer to *Unsuccessful Programming Recovery* in SI. DO NOT use "Proceed with Same VIN" to return to Supported Controllers screen.

Dealer Responsibility – For US and Export (US States, Territories, and Possessions)

It is a violation of Federal law for a dealer to deliver a new motor vehicle or any new or used item of motor vehicle equipment (including a tire) covered by this notification under a sale or lease until the defect or noncompliance is remedied.

The US National Traffic and Motor Vehicle Safety Act provides that each vehicle that is subject to a recall of this type must be adequately repaired within a reasonable time after the customer has tendered it for repair. A failure to repair within sixty days after tender of a vehicle is prima facie evidence of failure to repair within a reasonable time. If the condition is not adequately repaired within a reasonable time, the customer may be entitled to an identical or reasonably equivalent vehicle at no charge or to a refund of the purchase price less a reasonable allowance for depreciation. To avoid having to provide these burdensome remedies, every effort must be made to promptly schedule an appointment with each customer and to repair their vehicle as soon as possible. In the recall notification letters, customers are told how to contact the US National Highway Traffic Safety Administration if the recall is not completed within a reasonable time.

Dealer Responsibility – All

All new, used, GM Certified Used, courtesy transportation vehicles, dealer shuttle vehicles, etc. in dealers' possession and subject to this recall **must** be held and inspected/repaired per the service procedure of this bulletin **before** customers take possession of these vehicles. Involved vehicles must be held and not delivered to customers, dealer-traded, released to auction, used for demonstration, or any other purpose.

All GM Certified Used vehicles currently in the dealers' inventory within the Certified Pre-Owned Inventory System (CPOIS) will be de-certified and must be held and remedied per the service procedure in this bulletin. Upon submitting an accepted/paid warranty transaction in the Global Warranty Management (GWM) system, the vehicle can be re-certified for sale within the CPOIS system, or once again be used in the CTP program.

Dealers are to service all vehicles subject to this recall at no charge to customers, regardless of mileage, age of vehicle, or ownership, from this time forward.

Customers who have recently purchased vehicles sold from your vehicle inventory, and for which there is no customer information indicated on the dealer listing, are to be contacted by the dealer. Arrangements are to be made to make the required correction according to the instructions contained in this bulletin. A copy of the customer letter is provided in this bulletin for your use in contacting customers. Recall follow-up cards should not be used for this purpose, since the customer may not as yet have received the notification letter.

In summary, whenever a vehicle subject to this recall enters your vehicle inventory, or is in your dealership for service in the future, you must take the steps necessary to be sure the recall correction has been made before selling or releasing the vehicle.

Dealer Reports

For dealers with involved vehicles, a listing with involved vehicles has been prepared and will be provided to U.S. and Canadian dealers through the GM GlobalConnect Recall Reports, or sent directly to export dealers. The listing may contain customer names and addresses obtained from Motor Vehicle Registration Records. The use of such motor vehicle registration data for any purpose other than follow-up necessary to complete this recall is a violation of law in several states/provinces/countries. Accordingly, you are urged to limit the use of this report to the follow-up necessary to complete this recall.

Courtesy Transportation – For USA & Canada

Courtesy transportation is available for customers whose vehicles are involved in a product program and still within the warranty coverage period. See General Motors Service Policies and Procedures Manual, Section 6.1.10 – Courtesy Transportation, for details.

Customer Notification

USA & Canada - General Motors will notify customers of this recall on their vehicle (see copy of customer letter included with this bulletin).

Export - Letters will be sent to known owners of record located within areas covered by the US National Traffic and Motor Vehicle Safety Act. For owners outside these areas, dealers should notify customers using the attached sample letter.

Customer Reimbursement

Customer requests for reimbursement of previously paid repairs to correct the condition described in this bulletin are to be submitted to the dealer prior to or by September 30, 2017. See General Motors Service Policies and Procedures Manual, Section 6.1.11 –

Product Field Action Customer Reimbursement Procedure (USA & Canada) or local Policies and Procedures, for details.

IMPORTANT SAFETY RECALL

October 2016

This notice applies to your vehicle, **VIN:** _____

Dear General Motors Customer:

This notice is sent to you in accordance with the National Traffic and Motor Vehicle Safety Act.

General Motors has decided that a defect, which relates to motor vehicle safety, exists in certain 2014-2017 model year Chevrolet Silverado LD, GMC Sierra LD, Buick Encore, Chevrolet Trax, Chevrolet Caprice Police, and Chevrolet Corvette vehicles, 2014-2016 model year Buick Lacrosse, Chevrolet Spark EV, and Chevrolet SS vehicles and 2015-2017 model year Chevrolet Silverado HD, GMC Sierra HD, GMC Yukon, GMC Yukon XL, Cadillac Escalade Cadillac Escalade ESV, Chevrolet Suburban, and Chevrolet Tahoe vehicles. As a result, GM is conducting a safety recall. We apologize for this inconvenience. However, we are concerned about your safety and continued satisfaction with our products.

Important:

- Your vehicle is involved in GM recall 16007.
- Schedule an appointment with your GM dealer.
- This service will be performed for you at **no charge**.

Why is your vehicle being recalled?	The sensing and diagnostic module (SDM) in your vehicle, which controls airbag and pretensioner deployment, contains a software defect which may prevent the deployment of frontal airbags and pretensioners in certain rare circumstances. If the frontal airbags and seatbelt pretensioners do not deploy when required, there is an increased risk of injury to occupants in a crash.
What will we do?	Your GM dealer will reprogram the SDM with new software that eliminates this defect. If your vehicle has any previous deployment events recorded in the SDM, your dealer will replace the existing SDM with a new SDM containing the latest software. This service will be performed for you at no charge . Because of service scheduling requirements, it is likely that your dealer will need your vehicle longer than the actual service correction time of approximately 20 minutes up to two hours.
What should you do?	You should contact your GM dealer to arrange a service appointment as soon as possible.
Did you already pay for this repair?	Even though you may have already had repairs for this condition, you will still need to take your vehicle to your dealer for additional repairs. If you have paid for repairs for the recall condition,

please complete the enclosed reimbursement form and present it to your dealer with all required documents. Working with your dealer will expedite your request, however, if this is not convenient, you may mail the completed reimbursement form and all required documents to Reimbursement Department, PO Box 33170, Detroit, MI 48232-5170. The completed form and required documents must be presented to your dealer or received by the Reimbursement Department by October 31, 2017, unless state law specifies a longer reimbursement period.

Do you have questions?

If you have questions or concerns that your dealer is unable to resolve, please contact the appropriate Customer Assistance Center at the number listed below.

Division	Number	Text Telephones (TTY)
Buick	1-866-608-8080	1-800-832-8425
Cadillac	1-866-982-2339	1-800-833-2622
Chevrolet	1-800-630-2438	1-800-833-2438
GMC	1-866-996-9463	1-800-462-8583
Puerto Rico – English	1-800-496-9992	
Puerto Rico – Español	1-800-496-9993	
Virgin Islands	1-800-496-9994	

If after contacting your dealer and the Customer Assistance Center, you are still not satisfied we have done our best to remedy this condition without charge and within a reasonable time, you may wish to write the Administrator, National Highway Traffic Safety Administration, 1200 New Jersey Avenue, SE, Washington, DC 20590, or call the toll-free Vehicle Safety Hotline at 1.888.327.4236 (TTY 1.800.424.9153), or go to <http://www.safercar.gov>. The National Highway Traffic Safety Administration Campaign ID Number for this recall is 16V651.

Federal regulation requires that any vehicle lessor receiving this recall notice must forward a copy of this notice to the lessee within ten days.

Jeffrey M. Boyer

Vice President

Global Vehicle Safety

Enclosure

GM Recall 16007

GM bulletins are intended for use by professional technicians, NOT a "do-it-yourselfer". They are written to inform these technicians of conditions that may occur on some vehicles, or to provide information that could assist in the proper service of a vehicle. Properly trained technicians have the equipment, tools, safety instructions, and know-how to do a job properly and safely. If a condition is described, DO NOT assume that the bulletin applies to your vehicle, or that your vehicle will have that condition. See your GM dealer for information on whether your vehicle may benefit from the information.



WE SUPPORT
VOLUNTARY
TECHNICIAN
CERTIFICATION

PE18-012

GM

3-27-2019

Q3

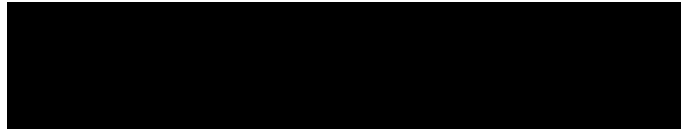

CHECKLIST: DOCUMENTS TO PROVIDE TO LOCAL COUNSEL UPON REMOVAL FROM ER

RE: [REDACTED] v. General Motors
 Service Request No. : [REDACTED]
 GM Legal Staff Case No. : [REDACTED]
 Year/Make/Model of Vehicle : 2016 Chevrolet Suburban
 VIN : 1GNSCHKC3GR [REDACTED]
 BRC-Legal Advisor Name: Courtney
 BRC-Legal Advisor E-Mail: courtney.lopez@gm.com

	ATTACHED	UNABLE TO OBTAIN	(for LC only) RECEIVED
Case Assessment (completed)	X		
BBB File (including Manufacturer’s Response Form – if applicable)	N/A		
<i>Service Activity Reports (SR’s):</i>			
CAC	N/A		
BBB/ADR	N/A		
TAC	N/A		
FRA	N/A		
LEGAL	X		
Repair Orders	X		
Sales Documents	X		
BARS Invoice	X		
GMVIS Warranty Information	X		
GMVIS Vehicle Build	X		
GMVIS Vehicle Component Summary	X		
GMVIS Vehicle Delivery Information	X		
GMVIS Vehicle Summary	X		
GMVIS Vehicle Transaction History	X		
Photos/Videos provided by Plaintiff, Dealer or DMA (if available)	N/A		
Correspondence/E-mails between GM & Plaintiff (ADR and CA CEC only)	X		
Correspondence/E-mails between GM & Plaintiff’s Counsel (including demands & offers)	X		
Correspondence/E-mails between GM & Dealer(s)	X		
Correspondence/E-mails between GM & DMA	X		

Note: In the event an item doesn’t apply, please insert **N/A** for “not applicable” in the “Attached” column.

PE18-012

GM

3-27-2019

Q3

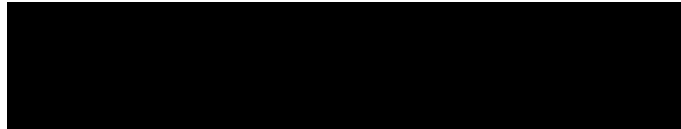



A Public Service Agency

TO OBTAIN A TITLE OR REGISTRATION CARD, MAIL THE ATTACHED DOCUMENTS AND REQUESTED ITEMS TO: DMV, PO BOX 942869, SACRAMENTO, CA 94269-0001. PENALTIES ARE DUE IF RENEWAL FEES ARE PAID AFTER THE EXPIRATION DATE. PLANNED NON-OPERATION (PNO) REQUESTS MUST BE SUBMITTED WITHIN 90 DAYS OF THE EXPIRATION DATE (ON OR BEFORE THE EXPIRATION DATE FOR OFF-HIGHWAY VEHICLES) OR ALL FEES AND PENALTIES ARE DUE. FOR A DMV OFFICE APPOINTMENT, GO ONLINE AT WWW.DMV.CA.GOV OR CALL 1-800 777-0133.

POSTING FEES ONLY

* * *



REPORT OF DEPOSIT OF FEES PAGE 1 OF 1



A Public Service Agency

* INCOMPLETE APPLICATION**SEE ABOVE**THIS IS NOT AN OPERATING PERMIT *

MAKE	YR MODEL	YR 1ST SOLD	VLF CLASS	TYPE VEH	TYPE LIC	LICENSE NUMBER
CHEV	2016	2015	PL	11S	00	[REDACTED]
BODY TYPE MODEL	MP	MO				VEHICLE/VESSEL ID NUMBER
LL	G	WZ				1GNSCHKC3GR [REDACTED]
TYPE VEHICLE/VESSEL USE	DATE ISSUED	CC/ALCO	DT FEE RECVD	PIC		
AUTOMOBILE	12/28/15	19	12/28/15	0		

RDF REASONS: U

AMOUNT PAID \$ 454.00

AMOUNT DUE	AMOUNT RECVD
\$ 454.00	CASH : 454.00
	CHCK :
	CRDT :

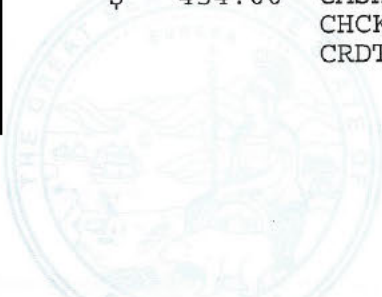

L / O

PE18-012

GM

3-27-2019

Q3

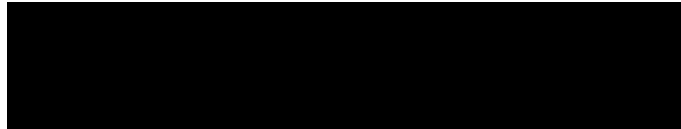



Jeralyn Vara

[Logout](#)

March 16, 2018

[Global Warranty Management: Main](#) > [Interface With Customer](#) > [View Vehicle Build](#)
**INTERFACE WITH
CUSTOMER**

View Vehicle Build



This screen allows IVH users to view the initial build information on the selected VIN including option codes with descriptions (where available).

Vehicle Information

VIN: 1GNSCHKC3GR

Model: CC15906-2016 SUBURBAN 1500 2WD

Service Contract: No Branded Title: No

Warranty Block: No

PDI Status: Yes

Order Type: 60 - RETAIL - SOLD

Field Actions: [Open](#)
[REQUEST ANOTHER VIN](#)

For this vehicle:

[View Vehicle Summary](#)
[Service Contract](#)
[Branded Title](#)
[Warranty Block](#)
[View Vehicle Build](#)
[View Vehicle Component Summary](#)
[View Vehicle](#)
[Transaction History Detail](#)
[View Vehicle Delivery Information](#)

Vehicle Build

Model: CC15906-2016 SUBURBAN 1500 2WD

Order Number:

Gross Vehicle Weight: 3,314

Build Date: 10/26/2015

Build Plant: R

Option Codes

*IVH is not the definitive source of GM Vehicle RPO information and is intended for service reference only. Should there be any questions about the vehicle's original build or RPO information please refer to the original vehicle invoice or window sticker.

1LT - 1LT PACKAGE

1SZ - OPTION PACKAGE DISCOUNT

4AA - INTERIOR TRIM

6SP - COMPONENT FRT LH COMPUTER

7SP - COMPONENT FRT RH COMPUTER

8X2 - COMPONENT RR LH NON-COMPUTER

9X2 - COMPONENT RR RH NON-COMPUTER

A31 - WINDOWS, POWER

A45 - DRIVER SEAT, MEMORY ADJUST

AG2 - SIX-WAY POWER PASSENGER SEAT

AKJ - WINDSHIELD STYLE SHADE BAND

AKK - WINDSHIELD, LAMINATED GLASS

AKO - GLASS, DEEP-TINTED

AKX - WINDSHIELD TYPE SOLAR ABSORB

AL0 - AIRBAG SENSING SYSTEM, PASSENGER

AN3 - SEATS, FRONT FULL FEATURE LEATHER APPOINTED BUCKETS & CENTER CONSOLE, FLOOR W/ USB PORTS

AP9 - CARGO NET

AQQ - REMOTE KEYLESS ENTRY

ARL - PLANT CODE-ARLINGTON, TX

ARN - AIRBORNE

ATV - SEATS, SECOND ROW BUCKET

AU3 - POWER DOOR LOCK SYSTEM

AXP - VEHICLE TYPE VEHICLE TYPE - NOT REQUIRED

AYQ - AIRBAGS

B30 - COLOR KEYED CARPET

B58 - FLOOR MATS, CARPETED, FRT/RR

BTV - REMOTE VEHICLE START

BVE - RUNNING BOARDS, ASSIST STEPS

C25 - INTERMITTENT FRONT WIPERS

C49 - REAR WINDOW DEFROSTER

C6A - GVW RATING - 7,300 LBS

CE1 - WINDSHIELD WIPERS, RAIN SENSING

CJ4 - CLIMATE CONTROL, TRI-ZONE AUTOMATIC

D07 - CENTER CONSOLE, FLOOR

DCP - PROCESSING DIRECTIONS & CONNECTIONS SERVICE PACKAGE

DD8 - INSIDE REARVIEW MIRROR, AUTO DIMMING

DL8 - POWER HEATED OUTSIDE MIRRORS

E2C - ORDER TO DELIVERY - EXPEDITE

EF7 - COUNTRY CODE, U.S.A.

FHO - VEHICLE FUEL GASOLINE E10

G80 - AUTO LOCKING REAR DIFFERENTIAL

GBA - BLACK

GU4 - REAR AXLE 3.08 RATIO

H2U - JET BLACK

I16 -

IO5 - CHEVROLET MYLINK AUDIO SYSTEM W/ 8" DIAGONAL COLOR TOUCH

JD9 - ANTILOCK BRAKES, 4 WHEEL DISC

JF4 - POWER ADJUSTABLE PEDALS

K34 - CRUISE CONTROL

KC4 - ENGINE OIL COOLING SYSTEM

KG4 - ALTERNATOR, 150 AMPS

KI4 - POWER OUTLET, 110-VOLT AC

KNP - HD AUX TRANS. COOLING SYS

L83 - ENGINE, 5.3L V8 ECOTEC3

MAH - MARKETING AREA NORTH AMERICA
N37 - STEERING COLUMN, TILT &
TELESCOPING

NUF - EMISSION SYSTEM CALIFORNIA
R5A - TIRE BRAND ALL CONTINENTAL

R9Z - POMS EXPEDITE-SOLD ORDERS/TSE
RD4 - WHEELS, 20" POLISHED ALUMINUM
(REPLACES STANDARD WHEELS)

SAF - SPARE TIRE LOCK

SLT - SALES PACKAGE

TG5 - SINGLE-SLOT CD/MP3 PLAYER

U2K - SIRIUSXM + SERVICE SUBSCRIPTION
SOLD SEPARATELY BY SIRIUSXM AFTER 3
MONTHS

U77 - ANTENNA RR WINDOW, RADIO

UDD - DRIVER INFO - COLOR DISPLAY

UEU - FORWARD COLLISION ALERT

UHX - LANE KEEP ASSIST

UK3 - STEERING WHEEL AUDIO CONTROLS

UQA - BOSE AUDIO SYSTEM

UVC - REAR VISION CAMERA

V8D - VEHICLE STATEMENT

VK3 - FRONT LICENSE PLATE BRACKET

VT7 - OWNERS MANUAL ENGLISH

WMG -

XL7 - FREQUENCY RATING 315 MH

YF5 - 50-STATE EMISSIONS

ZW7 - PREMIUM RIDE SUSPENSION

MYC - TRANSMISSION, 6 SPD AUTOMATIC

NP5 - LEATHER WRAP STEERING WHEEL

QSS - TIRES, ALL SEASON

R9N - FORCE ON ALL VEHICLES FOR PRICING OF
INTERIOR TRIM

RC4 - TIRE, SPARE 17" ALL SEASON BLACKWALL

RUF - WHEEL, 17" STEEL SPARE

SLL - SOLD ORDERS

TB5 - REAR LIFTGATE, POWER

TQ5 - INTELLIBEAM

U2L - HD RADIO

UD7 - REAR PARK ASSIST

UE1 - ONSTAR

UG1 - UNIVERSAL HOME REMOTE

UJM - TIRE PRESSURE MONITOR SYSTEM (EXCL SPARE
TIRE)

UMN - SPEEDOMETER, MILES & KILO, MILES FOR
ODOMETER

UTJ - THEFT DETERRENT SYSTEM

V54 - LUGGAGE RACK - SIDE RAILS

VHM - VEHICLE HEALTH MANAGEMENT

VRK - VAA/COMPONENT REL ROOF TRIM

VV4 - 4G LTE WI-FI(R) HOTSPOT WITH L MITED DATA
TRIAL AND MORE. (SUBJECT TO TERMS SEE
ONSTAR.COM)

X88 - CHEVROLET CONVERSION

Y86 - DRIVER ALERT PACKAGE

Z82 - TRAILERING EQUIPMENT

ZY1 - SOLID PAINT

Added Option Codes

#BI -

Global Warranty Management: [Site Map](#)

[Privacy Policy](#) | [Terms of Use](#)

© 2005 General Motors. All rights reserved

PE18-012

GM

3-27-2019

Q3

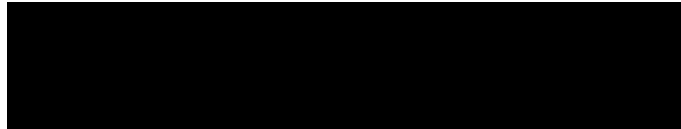



Jeralyn Vara

[Logout](#)

March 16, 2018

Global Warranty Management: [Main](#) > [Interface With Customer](#) > [View Vehicle Component Summary](#)**INTERFACE WITH
CUSTOMER**

View Vehicle Component Summary



This screen allows IVH users to view the information on various major components added to the VIN selected during vehicle build.

Vehicle Information

VIN: 1GNSCHKC3GR [REDACTED] Model: CC15906-2016 SUBURBAN 1500 2WD
 Service Contract: No Branded Title: No Warranty Block: No PDI Status: Yes
 Order Type: 60 - RETAIL - SOLD
 Field Actions: [Open](#)

[REQUEST ANOTHER VIN](#)
For this vehicle:

- [View Vehicle Summary](#)
 - Service Contract
 - Branded Title
 - Warranty Block
- [View Vehicle Build](#)
- [View Vehicle Component Summary](#)
- [View Vehicle Transaction History Detail](#)
- [View Vehicle Delivery Information](#)

Vehicle Component

Component Code: 61-TRANSMISSION	Traceability: [REDACTED]
Source Plant: A-HYDRAMATIC FLINT, MICHIGAN	Part / Number Broadcast: 5CCA
Date Scanned: 10/26/2015	Time Scanned: 05:22:00 Scan Station: 01
Component Code: 99-SPEAKER AMPLIFIER	Traceability: [REDACTED]
Source Plant: B-BOSE FRAMINGHAM, MASSACHUSETTS	Part / Number Broadcast: 4898
Date Scanned: 10/26/2015	Time Scanned: 09:41:00 Scan Station: 01
Component Code: AH-IR-SENSOR ASM-LEFT	Traceability: [REDACTED]
Source Plant: D-ALLIED SIGNAL BSRD	Part / Number Broadcast: 8676
Date Scanned: 10/26/2015	Time Scanned: 09:41:00 Scan Station: 01
Component Code: AJ-IR-SENSOR ASM-RIGHT	Traceability: [REDACTED]
Source Plant: D-ALLIED SIGNAL BSRD	Part / Number Broadcast: 8676
Date Scanned: 10/26/2015	Time Scanned: 09:41:00 Scan Station: 01
Component Code: AT-RIGHT SIDE IMPACT SENSING MODULE	Traceability: [REDACTED]
Source Plant: D-ALLIED SIGNAL BSRD	Part / Number Broadcast: 8677
Date Scanned: 10/26/2015	Time Scanned: 09:41:00 Scan Station: 01
Component Code: AU-LEFT SIDE IMPACT SENSING MODULE	Traceability: [REDACTED]
Source Plant: D-ALLIED SIGNAL BSRD	Part / Number Broadcast: 8677
Date Scanned: 10/26/2015	Time Scanned: 09:41:00 Scan Station: 01
Component Code: BR-SENSOR ASSY - (PSIR) PRESENCE DETECTOR	Traceability: [REDACTED]
Source Plant: S-	Part / Number Broadcast: 3680
Date Scanned: 10/26/2015	Time Scanned: 09:41:00 Scan Station: 01
Component Code: CB-SEQ NUM (FLEX) BODY ASM	Traceability: [REDACTED]
Source Plant: -	Part / Number Broadcast: 1ZZ
Date Scanned: 10/16/2015	Time Scanned: 01:32:00 Scan Station:
Component Code: CG-SEQ NUM (FLEX) PAINT PROCESS	Traceability: [REDACTED]
Source Plant: -	Part / Number Broadcast: 1GG
Date Scanned: 10/24/2015	Time Scanned: 13:44:00 Scan Station:
Component Code: CH-SEQ NUM (FLEX) PAINT PROCESS	Traceability: [REDACTED]

Source Plant: -
Date Scanned: 10/24/2015

Part / Number Broadcast: 1HH
Time Scanned: 03:01:00 Scan Station:

Component Code: CN-SEQ NUM (FLEX) GEN ASM
Source Plant: -
Date Scanned: 10/24/2015

Traceability: [REDACTED]
Part / Number Broadcast: 1EE
Time Scanned: 23:07:00 Scan Station:

Component Code: CP-SEQ NUM (FLEX) GEN ASM
Source Plant: -
Date Scanned: 10/26/2015

Traceability: [REDACTED]
Part / Number Broadcast: 1AZ
Time Scanned: 00:23:00 Scan Station:

Component Code: DA----
Source Plant: D-
Date Scanned: 10/26/2015

Traceability: [REDACTED]
Part / Number Broadcast: 8678
Time Scanned: 09:41:00 Scan Station: 01

Component Code: DB----
Source Plant: D-
Date Scanned: 10/26/2015

Traceability: [REDACTED] 7
Part / Number Broadcast: 8678
Time Scanned: 09:41:00 Scan Station: 01

Component Code: DV----
Source Plant: Q-
Date Scanned: 10/26/2015

Traceability: [REDACTED]
Part / Number Broadcast: 0598
Time Scanned: 09:41:00 Scan Station: 01

Service Agent Installed Component

Vehicle has no current record of vehicle component.

PE18-012

GM

3-27-2019

Q3

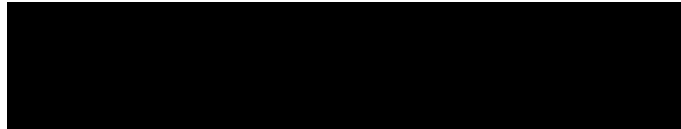



Jeralyn Vara

[Logout](#)

March 16, 2018

Global Warranty Management: [Main](#) > [Interface With Customer](#) > [View Vehicle Delivery Information](#)**INTERFACE WITH
CUSTOMER**

View Vehicle Delivery Information



This screen allows IVH users to view the available information for the selected VIN delivered to the Service Agent and the ultimate customer. Not all sections will be populated for all VINs.

Vehicle Information

VIN: 1GNSCHKC3GR [REDACTED] Model: CC15906-2016 SUBURBAN 1500 2WD
 Service Contract: No Branded Title: No Warranty Block: No PDI Status: Yes
 Order Type: 60 - RETAIL - SOLD
 Field Actions: [Open](#) [REQUEST ANOTHER VIN](#)

For this vehicle:

- [View Vehicle Summary](#)
- Service Contract
- Branded Title
- Warranty Block
- [View Vehicle Build](#)
- [View Vehicle Component Summary](#)
- [View Vehicle Transaction History Detail](#)
- [View Vehicle Delivery Information](#)

Invoice Information

Invoicing Service Agent: 114549 Invoice Date: 10/26/2015
 CAMINO REAL CHEVROLET
 2401 S ATLANTIC BLVD
 MONTEREY PARK CA 91754-6807 3232643050

Ship to Information

Ship to Service Agent: 114549 Ship to Date: N/A
 CAMINO REAL CHEVROLET
 2401 S ATLANTIC BLVD
 MONTEREY PARK CA 91754-6807 3232643050

Delivery Information

Delivery Service Agent: 114549 Delivery Date: 12/11/2015
 CAMINO REAL CHEVROLET Delivery Type: 010--INDIVIDUAL
 2401 S ATLANTIC BLVD Delivery Odometer: 4
 MONTEREY PARK CA 91754-6807 3232643050

In Service Information

Invoicing Service Agent: In Service Date: N/A
 In Service Type: 0000
 In Service Odometer: 0

Registration Information

Registration Service Agent: N/A Registration Date: N/A
 Registration Number: N/A
 Registration Odometer: 0

Global Warranty Management: [Site Map](#)[Privacy Policy](#) | [Terms of Use](#)

© 2005 General Motors. All rights reserved.

PE18-012

GM

3-27-2019

Q3

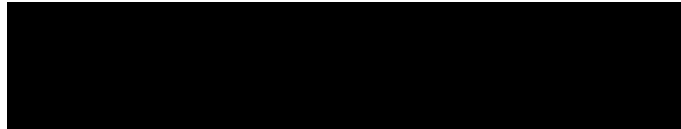



Jeralyn Vara

[Logout](#)

March 16, 2018

Global Warranty Management: [Main](#) > [Interface With Customer](#) > [View Vehicle Summary](#)**INTERFACE WITH
CUSTOMER**

View Vehicle Summary



This screen allows IVH users to view the Summary of Vehicle Information, Field Actions, Service Information, Applicable Warranties, Transaction History, Service Contract(s) if applicable, Warranty Block, Branded Title information and OnStar and XM Radio information (if applicable).

For this vehicle:

- [View Vehicle Summary](#)
 - Service Contract
 - Branded Title
 - Warranty Block
- [View Vehicle Build](#)
- [View Vehicle Component Summary](#)
- [View Vehicle Transaction History Detail](#)
- [View Vehicle Delivery Information](#)

Vehicle Information

VIN: 1GNSCHKC3GR [REDACTED] Model: CC15906-2016 SUBURBAN 1500 2WD
 Service Contract: No Branded Title: No Warranty Block: No PDI Status: Yes
 Order Type: 60 - RETAIL - SOLD
 Field Actions: [0 Open](#)

[REQUEST ANOTHER VIN](#)
Required Field Actions

Open Field Action Details are highlighted

Type	Number	Original Nbr	Description	Release Date	Status
Product Safety Recall	[REDACTED]	[REDACTED]	Frontal Airbag And Pretensioner Non Deploy	09/08/2016	Closed

Branded Title

*The VIN information contained herein and information derived therefrom is the proprietary property of The Polk Company and is to be used only for the purpose of warranty verification and shall not be used for any other purpose whatsoever.

Vehicle has no current record of branded titles.

Warranty Block

Vehicle has no current record of warranty block.

Service Information

Type	Number	Description	Posted Date
EI	PIE0365		06/21/2016
EI	PIE0359	Vehicle Crank with No Start or Stalling with DTC P0011 and/or P00C6 Set	03/15/2016

OnStar and XM Satellite Radio Information

Refer to Help page for details. For OnStar contact 888.ON.STAR1 (888.667.8271) and for XM Radio contact 877.GET.XMST (877.438.9677 Canada) and in the USA:800-556-3600.

OnStar Equipped: Y OnStar Status: **Active**
 XM Equipped: Y XM Radio ID: A48WG382 XM Status: **Active**
 OnStar Vehicle Diagnostics: N DMN Enabled: **N**

Applicable Warranties

Valid warranties are highlighted

Valid	Description	Warranty Add Date	Start Date	Effective Odometer	End Date	End Odometer
	Bumper to Bumper Limited Warranty	02/15/2018	12/11/2015	4 MI	12/11/2018	36,004 MI

Powertrain Limited Warranty	02/15/2018	12/11/2015	4 MI	12/11/2020	60,004 MI
Special Coverage 17336	02/15/2018	12/11/2015	4 MI	12/11/2020	60,004 MI
Corrosion Limited Warranty	02/15/2018	12/11/2015	4 MI	12/11/2021	100,004 MI
Emission Limited Warranty	02/15/2018	12/11/2015	4 MI	12/11/2018	50,004 MI
Emission Select Component Ltd Wty	02/15/2018	12/11/2015	4 MI	12/11/2023	80,004 MI
Emission Select State Component Ltd Wty	02/15/2018	12/11/2015	4 MI	12/11/2022	70,004 MI
Chevrolet Scheduled Maintenance-2 visits	02/15/2018	12/11/2015	4 MI	12/11/2017	24,004 MI

Service Contract

Vehicle has no current record of service contracts.

Transaction History

[View Details](#)

Job Card Date	Job Card Number	Transaction Type	Transaction Adjustment	Labour Operation	Odometer Reading
12/26/2017	██████	ZREG----Regular Vehicle Transaction		4413100 - Heater Inlet Hose Replacement	26,031 MI
12/26/2017	██████	ZREG----Regular Vehicle Transaction		8466430 - 4-5-6 Clutch Plate Replacement	26,031 MI
12/26/2017	██████	ZREG----Regular Vehicle Transaction		4065910 - Lower Oil Pan Replacement	26,031 MI
12/26/2017	██████	ZREG----Regular Vehicle Transaction		4067080 - Engine Mount Replacement - Left Side	26,031 MI
07/26/2017	██████	ZREG----Regular Vehicle Transaction		4050272 - Exhaust System Alignment	22,426 MI
07/01/2017	██████	ZREG----Regular Vehicle Transaction		4041510 - Battery Replacement	19,614 MI
07/01/2017	██████	ZREG----Regular Vehicle Transaction	Add Credit	8466450 - 3-5-Reverse Clutch Plate Replacement	19,614 MI
07/01/2017	██████	ZREG----Regular Vehicle Transaction	Full Debit - Reversal	8466450 - 3-5-Reverse Clutch Plate Replacement	19,614 MI
07/01/2017	██████	ZREG----Regular Vehicle Transaction		8466450 - 3-5-Reverse Clutch Plate Replacement	19,614 MI
07/01/2017	██████	ZREG----Regular Vehicle Transaction		0600642 - Roadside - Over Mileage	19,164 MI
07/01/2017	██████	ZREG----Regular Vehicle Transaction		0600022 - ROADSIDE SERVICE (TOWING)	19,164 MI
06/27/2017	██████	ZREG----Regular Vehicle Transaction		2480118 - Replace vacuum pump, vacuum pump to booster hose, vacuum brake booster, and brake master cylinder	19,529 MI
06/27/2017	██████	ZFAT----Field Action Recall		9102276 - 16007 - N16-204817 - Reprogram Inflatable Restraint Sensing and Diagnostic Module Calibrations	19,529 MI
11/02/2015	██████	ZPDI----Pre-Delivery Inspection		0590072 - Pre-Delivery Inspection - Base Time	1 MI

Global Warranty Management: [Site Map](#)

[Privacy Policy](#) | [Terms of Use](#)

© 2005 General Motors. All rights reserved.

PE18-012

GM

3-27-2019

Q3

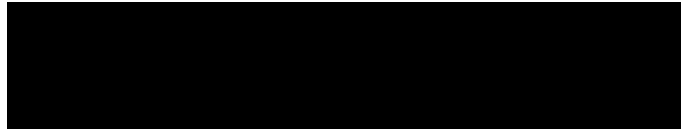



Jeralyn Vara

[Logout](#)

March 16, 2018

Global Warranty Management: [Main](#) > [Interface With Customer](#) > [View Vehicle Transaction History Detail](#)

INTERFACE WITH CUSTOMER

View Vehicle Transaction History Detail



This screen allows IVH users to view the available information on individual transaction for the VIN selected.

Vehicle Information

VIN: 1GNSCHKC3GR [REDACTED] Model: CC15906-2016 SUBURBAN 1500 2WD
 Service Contract: No Branded Title: No Warranty Block: No PDI Status: Yes
 Order Type: 60 - RETAIL - SOLD
 Field Actions: [Open](#)

[REQUEST ANOTHER VIN](#)

For this vehicle:

- [View Vehicle Summary](#)
 - Service Contract
 - Branded Title
 - Warranty Block
- [View Vehicle Build](#)
- [View Vehicle Component Summary](#)
- [View Vehicle Transaction History Detail](#)
- [View Vehicle Delivery Information](#)

Job Card Date: 12/26/2017

Job Card Number: [REDACTED]

Transaction Detail

Repair Service Agent: 259910
 KEYES CHEVROLET
 5949 N VAN NUYS BLVD
 VAN NUYS CA 91401-3319
 8182671400

Odometer Reading: 26,031 MI
 Authorization Code:

Process Date:
03/02/2018

Transaction Type:
ZREG----Regular Vehicle Transaction
 Transaction Expense Category:
Warranty

Customer Complaint Code:
0722-Heating/Ventilation/Air conditioning
- A/C Performance

Job Card Line #: 62

Transaction Adjustment:

Cause Code: 4061-Interface (Gasket, Seal, Hose, Weld..) - Leaks

Labour Op 4413100-Heater Inlet Hose Replacement

Causal Part Number 00000000023492578-HOSE-HTR INL
 → [See other Parts and/or Net Items](#)

Line Total: USD 198 08

Job Card Date: 12/26/2017

Job Card Number: [REDACTED]

Transaction Detail

Repair Service Agent: 259910
 KEYES CHEVROLET
 5949 N VAN NUYS BLVD
 VAN NUYS CA 91401-3319
 8182671400

Odometer Reading: 26,031 MI
 Authorization Code: E7P8

Process Date:
02/09/2018

Transaction Type:
ZREG----Regular Vehicle Transaction

Transaction Expense Category:
Warranty

Customer Complaint Code:
0341-Transmission - Transmission Performance

Job Card Line #: 54

Transaction Adjustment:

Cause Code: 6021-Module/Component - Damaged/Cracked

Labour Op 8466430-4-5-6 Clutch Plate Replacement

Causal Part Number 00000000024248008-PLATE PKG,CLU

→ [See other Parts and/or Net Items](#)

Line Total: USD 2,228 22

Job Card Date: 12/26/2017 **Job Card Number:** [REDACTED] **Transaction Detail**

Repair Service Agent: 259910
KEYES CHEVROLET
5949 N VAN NUYS BLVD
VAN NUYS CA 91401-3319
8182671400

Odometer Reading: 26,031 MI
Authorization Code:

Process Date:
01/26/2018

Transaction Type:
ZREG----Regular Vehicle
Transaction

Transaction Expense Category:
Warranty

Customer Complaint Code:
0327-Engine/Fuel/Exhaust - Fluid
Leaks

Job Card Line #: 52 Transaction Adjustment: Cause Code: 4061-Interface (Gasket, Seal, Hose,
Weld..) - Leaks

Labour Op 4065910-Lower Oil Pan Replacement

Causal Part Number 00000000088864346-SEALANT,RTV SILICONE TUBE TB 1217 ACDELCO

→ [See other Parts and/or Net Items](#)

Line Total: USD 209 06

Job Card Date: 12/26/2017 **Job Card Number:** [REDACTED] **Transaction Detail**

Repair Service Agent: 259910
KEYES CHEVROLET
5949 N VAN NUYS BLVD
VAN NUYS CA 91401-3319
8182671400

Odometer Reading: 26,031 MI
Authorization Code:

Process Date:
01/26/2018

Transaction Type:
ZREG----Regular Vehicle Transaction

Transaction Expense Category:
Warranty

Customer Complaint Code:
0322-Engine/Fuel/Exhaust - Engine
Performance

Job Card Line #: 51 Transaction Adjustment: Cause Code: 6017-Module/Component -
Broken

Labour Op 4067080-Engine Mount Replacement - Left Side

Causal Part Number 00000000084175583-MOUNT ASM-ENG

→ [See other Parts and/or Net Items](#)

Line Total: USD 454 23

Job Card Date: 07/26/2017 **Job Card Number:** [REDACTED] **Transaction Detail**

Repair Service Agent: 259910
KEYES CHEVROLET
5949 N VAN NUYS BLVD
VAN NUYS CA 91401-3319
8182671400

Odometer Reading: 22,426 MI
Authorization Code:

Process Date:
08/01/2017

Transaction Type:
ZREG----Regular Vehicle
Transaction

Transaction Expense Category:
Warranty

Customer Complaint Code:
0326-Engine/Fuel/Exhaust -
Exhaust

Job Card Line #: 51

Transaction Adjustment:

Cause Code: 5011-Fastener -
Alignment/Adjustment

Labour Op 4050272-Exhaust System Alignment

Causal Part Number

→ [See other Parts and/or Net Items](#)

Line Total: USD 120 59

Job Card Date: 07/01/2017

Job Card Number: [REDACTED]

[Transaction Detail](#)

Repair Service Agent: 259910

Odometer Reading: 19,614 MI

KEYES CHEVROLET
5949 N VAN NUYS BLVD
VAN NUYS CA 91401-3319
8182671400

Authorization Code: K8

Process Date:
07/25/2017

Transaction Type:
ZREG----Regular Vehicle
Transaction

Transaction Expense Category:
Warranty

Customer Complaint Code:
0328-Engine/Fuel/Exhaust - No
Start

Job Card Line #: 62

Transaction Adjustment:

Cause Code: 6571-Module/Component -
Discharge

Labour Op 4041510-Battery Replacement

Causal Part Number 00000000088865934-BATTERY ASM,,LN4

→ [See other Parts and/or Net Items](#)

Line Total: USD 305 59

Job Card Date: 07/01/2017

Job Card Number: [REDACTED]

[Transaction Detail](#)

Repair Service Agent: 259910

Odometer Reading: 19,614 MI

KEYES CHEVROLET
5949 N VAN NUYS BLVD
VAN NUYS CA 91401-3319
8182671400

Authorization Code: C8D8E7P8

Process Date:
08/01/2017

Transaction Type:
ZREG----Regular Vehicle
Transaction

Transaction Expense Category:
Warranty

Customer Complaint Code:
0341-Transmission -
Transmission Performance

Job Card Line #: 51

Transaction Adjustment: Add Credit

Cause Code: 6021-Module/Component -
Damaged/Cracked

Labour Op 8466450-3-5-Reverse Clutch Plate Replacement

Causal Part Number 00000000024232497-PLATE-2-6 CLU

→ [See other Parts and/or Net Items](#)

Line Total: USD 3,288.16

Job Card Date: 07/01/2017 Job Card Number: [REDACTED] [Transaction Detail](#)

Repair Service Agent: 259910
KEYES CHEVROLET
5949 N VAN NUYS BLVD
VAN NUYS CA 91401-3319
8182671400

Odometer Reading: 19,614 MI
Authorization Code: C8D8E7P8

Process Date:
08/01/2017

Transaction Type:
ZREG----Regular Vehicle
Transaction

Transaction Expense Category:
Warranty

Customer Complaint Code:
0341-Transmission -
Transmission Performance

Job Card Line #: 51 Transaction Adjustment: Full Debit Cause Code: 6021-Module/Component -
Damaged/Cracked

Labour Op 8466450-3-5-Reverse Clutch Plate Replacement
Causal Part Number 00000000024232497-PLATE-2-6 CLU
→ [See o her Parts and/or Net Items](#)

Line Total: USD 3,259.71

Job Card Date: 07/01/2017 Job Card Number: [REDACTED] [Transaction Detail](#)

Repair Service Agent: 259910
KEYES CHEVROLET
5949 N VAN NUYS BLVD
VAN NUYS CA 91401-3319
8182671400

Odometer Reading: 19,614 MI
Authorization Code: C8D8E7P8

Process Date:
07/26/2017

Transaction Type:
ZREG----Regular Vehicle
Transaction

Transaction Expense Category:
Warranty

Customer Complaint Code:
0341-Transmission - Transmission
Performance

Job Card Line #: 51 Transaction Adjustment: Cause Code: 6021-Module/Component -
Damaged/Cracked

Labour Op 8466450-3-5-Reverse Clutch Plate Replacement
Causal Part Number 00000000024232497-PLATE-2-6 CLU
→ [See o her Parts and/or Net Items](#)

Line Total: USD 3,259.71

Job Card Date: 07/01/2017 Job Card Number: [REDACTED] [Transaction Detail](#)

Repair Service Agent: 257619
ALLSTATE - SIGNATURE MOTOR CLUB, IN
200 N MARTINGALE RD
SCHAUMBURG IL 60173-2033

Odometer Reading: 19,164 MI
Au horization Code: AM

Process Date:
07/03/2017

Transaction Type:
ZREG----Regular Vehicle Transaction

Transaction Expense Category:
Warranty

Customer Complaint Code:
0090-No Customer Complaint - O her

issues

Job Card Line #: 2

Transaction Adjustment:

Cause Code: 9094-Other - Follow
operation

Labour Op 0600642-Roadside - Over Mileage

Causal Part Number

→ [See o her Parts and/or Net Items](#)

Line Total: USD 24 38

Job Card Date: 07/01/2017

Job Card Number: [REDACTED]

[Transaction Detail](#)

Repair Service Agent: 257619

Odometer Reading: 19,164 MI

ALLSTATE - SIGNATURE MOTOR CLUB, IN
200 N MARTINGALE RD
SCHAUMBURG IL 60173-2033

Au horization Code: AM

Process Date:

07/03/2017

Transaction Type:

ZREG----Regular Vehicle Transaction

Transaction Expense Category:

Warranty

Customer Complaint Code:

0090-No Customer Complaint - O her
issues

Job Card Line #: 1

Transaction Adjustment:

Cause Code: 9094-Other - Follow
operation

Labour Op 0600022-ROADSIDE SERVICE (TOWING)

Causal Part Number

→ [See o her Parts and/or Net Items](#)

Line Total: USD 66 03

Job Card Date: 06/27/2017

Job Card Number: [REDACTED]

[Transaction Detail](#)

Repair Service Agent: 259910

Odometer Reading: 19,529 MI

KEYES CHEVROLET
5949 N VAN NUYS BLVD
VAN NUYS CA 91401-3319
8182671400

Authorization Code:

Process Date:

07/03/2017

Transaction Type:

ZREG----Regular Vehicle
Transaction

Transaction Expense Category:

Warranty

Customer Complaint Code:

0131-Brakes - Low Pedal/Spongy

Job Card Line #: 51

Transaction Adjustment:

Cause Code: 6061-Module/Component -
LeaksLabour Op 2480118-Replace vacuum pump, vacuum pump to booster hose, vacuum brake booster, and brake
master cylinder

Causal Part Number 00000000012669488-PUMP ASM-VAC

→ [See o her Parts and/or Net Items](#)

Line Total: USD 951.78

Job Card Date: 06/27/2017

Job Card Number: [REDACTED]

[Transaction Detail](#)

Repair Service Agent: 259910

Odometer Reading: 19,529 MI

KEYES CHEVROLET
5949 N VAN NUYS BLVD
VAN NUYS CA 91401-3319
8182671400

Authorization Code:

Process Date:
07/03/2017

Transaction Type:
ZFAT----Field Action Recall

Transaction Expense Category:
Field Action Recall

Customer Complaint Code:
-

Job Card Line #: 40 Transaction Adjustment: Cause Code: -

Labour Op 9102276-16007 - N16-204817 - Reprogram Inflatable Restraint Sensing and Diagnostic Module
Calibrations

Causal Part Number

Line Total: USD 44.59

Job Card Date: 11/02/2015

Job Card Number: [REDACTED]

[Transaction Detail](#)

Repair Service Agent: 114549
CAMINO REAL CHEVROLET
2401 S ATLANTIC BLVD
MONTEREY PARK CA 91754-6807
3232643050

Odometer Reading: 1 MI
Authorization Code:

Process Date:
11/03/2015

Transaction Type:
ZPDI----Pre-Delivery Inspection

Transaction Expense Category:
Pre-Delivery Inspection

Customer Complaint Code:
-

Job Card Line #: 1 Transaction Adjustment: Cause Code: -

Labour Op 0590072-Pre-Delivery Inspection - Base Time

Causal Part Number

Line Total: USD 148.64

Global Warranty Management: [Site Map](#)

[Privacy Policy](#) | [Terms of Use](#)

© 2005 General Motors. All rights reserved.

PE18-012

GM

3-27-2019

Q3

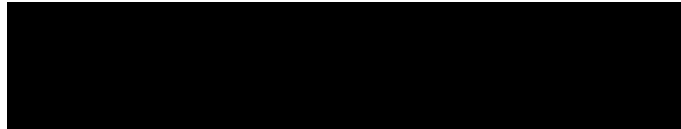



General Motors - Policy Evaluation Tool

Date: 03/05/2018

Customer Information

First Name: [Redacted]
 Last Name: [Redacted]
 Phone: [Redacted]

Agent Information

Agent Name: Siebel Service
 Agent Role:

Vehicle/Coverage Information

VIN: 3GTU2VEC1FG [Redacted] Make: GMC
 Component Warranty Coverage: Bumper to Bumper Coverage
 Ownership Status Message:

Time

Component's Warranty End Date: 07/17/2018
 Job Card Date: 03/01/2018
 Days out of Warranty: 0

Mileage

Component's Warranty End Mileage (Miles): 36,068
 Current Mileage: 48,000
 Miles out of Warranty: 11,932

Repair

Total Repair Cost At Warranty Rates: \$444.42 | Job Card / Repair Order : tier2
 Repair Group: Engine Propulsion

Reasons For Policy Adjustment

Primary reason for policy adjustment: Just beyond terms of applicable warranty coverage (Time or Mileage)

Important: This Policy Evaluation Tool is for GM Dealer and General Motor use ONLY

GM Participation Amount: \$244.43 - \$333.32 | Cust/Dir Participation Amount: \$111.11 - \$199.99
 Agreed upon Customer/Dealer Participation Amount:

Please print this document and the supporting IVH document and attach to the 'Hard Copy'.

Please note, every customer's situation must be evaluated on a Case-by-Case basis. If you decide to modify the participation amounts, contact your DMA using the DMA Pre-Approval form.

IMPORTANT: Enter the agreed upon amount in the Customer / Dealer Participation field in the claim transaction. Utilize IVH to validate warranty coverage end (time and mileage) of the component under consideration.



PE18-012

GM

3-27-2019

Q3

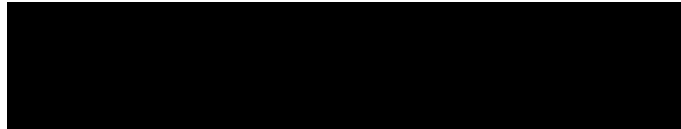

Connecting... An agent will be with you shortly.

Caller English

System [12:21:15 PM]:

Welcome to chat.

Scott [12:21:58 PM]:

Thank you for contacting GMC Customer Assistance. My name is Scott. Your safety is very important to us at GMC, so please remember to not use any hand held device whenever you're driving. I am sorry to hear you are experiencing this concern with the brakes, [REDACTED]

[REDACTED] [12:23:47 PM]:

found a tsb relating to this issue tsb# pit5361 MY truck is currently at 76000 miles and this problem has been on and off for the last few weeks

[REDACTED] [12:24:11 PM]:

if I bring into dealer I don't want to be charged for service

Scott [12:25:15 PM]:

A technical service bulletin is an aid for the dealership to assist them with addressing a concern on a vehicle; however, it does not mean there is any additional coverage offered outside of the factory warranty parameters. They are internal documents only between General Motors and the service department at our local dealerships. They are not for customers, nor are they in any way recalls, so any such work needed if there is a TSB would still be at the responsibility of the customer. I do apologize, but we do not discuss Technical Service Bulletins with the customer at all.

Scott [12:25:36 PM]:

The information you entered into the pre-chat form for your name, email address, and phone number is accurate and I can use for documentation?

[REDACTED] [12:26:19 PM]:

yes all correct

Scott [12:26:56 PM]:

Thank you! To ensure your information on file is updated and accurate, can you please provide your address, [REDACTED]

[REDACTED] [12:27:13 PM]:

[REDACTED]

Scott [12:27:55 PM]:

I appreciate you providing that information, [REDACTED] Have you taken the vehicle to a GMC Certified Dealership for this concern?

[REDACTED] [12:29:37 PM]:

Not yet

Scott [12:32:50 PM]:

Thank you! Do you have a GMC Certified Dealership in mind you would like to work with, [REDACTED] If not I will be happy to locate the nearest dealership in your area.

[REDACTED] [12:33:44 PM]:

I have one in Hammond

Scott [12:35:16 PM]:

Sounds Great! What I can advise is once the dealership diagnose the concern with the brakes, [REDACTED] If you need further assistance please do not hesitate to chat back in reference this case number [REDACTED] and we will be happy to assist further.

Scott [12:43:18 PM]:

I am still available to help you with any questions; I just want to make sure you are still there.

Scott [12:44:25 PM]:

I will be ending this chat session due to no response. If you have additional questions, please feel free to contact us again. We are here to chat Monday through Friday from 8:00 a.m. to 11:00 p.m., Saturday from 9:00 a.m. to 11:00 p.m. Thank you for contacting GMC Customer Assistance.

Call Disconnected.

PE18-012

GM

3-27-2019

Q3

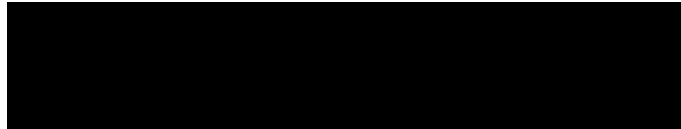



Monday, July 23, 2018

[Redacted]

Straight Settlement Letter

Subject: Repurchase of 2015 GMC Sierra
VIN: 1GTV2UEC3FZ [Redacted]
Ref SR [Redacted]

Dear [Redacted]

We regret that you are dissatisfied with your 2015 GMC Sierra, VIN 1GTV2UEC3FZ [Redacted] and that our attempts to resolve your concerns have not met your expectations. GMC will repurchase this vehicle in exchange for the release of liability stemming from warranties, express or implied, covering this vehicle.

This offer is being made in an effort to keep you a satisfied GMC customer. GMC will repurchase your vehicle for \$42,273.55. This offer was calculated by using the following figures:

Down Payment	\$500.00
Payments	\$15,600.00
Less Usage	\$780.67
Less Surface Protection	\$795.00
Less Extended Service Contract	\$2,501.00
Less Gap Insurance	\$895.00
Total Amount to Customer	\$11,128.33
Less Payoff of Original Vehicle-Good until 08/09/2018	\$31,145.22
Total Repurchase Amount (including sales tax of \$3666.48)	\$42,273.55

****AMOUNT IS SUBJECT TO CHANGE IF SIGNED PAPERWORK IS NOT RECEIVED BY DATE OUTLINED BELOW****

If you owe money to General Motors, please send certified check or money order made payable to General Motors.

If this offer is acceptable, please sign this letter and return it to my attention via the fax number or address listed below. I will contact you to set up a signing date, at which time you will be required to complete the 66-802-6625 if you have any questions or concerns.

[Redacted]

7.24.18
Signature(s) and Date

Customer's and Co-Customer's Printed Name(s)

[Redacted]



The requirements of the straight repurchase are as follows:

- ⇒ **Vehicle Damage** - vehicle is free from any abnormal damage, which impair its resale value. Vehicle must be inspected by a General Motors dealership at time of closing.
- ⇒ **Vehicle Alterations** - if this vehicle has been altered or modified from its original factory condition, it must be restored to its original condition before the scheduled repurchase appointment
- ⇒ **A “Power of Attorney” form** - supplied by General Motors must be signed and notarized at the time of repurchase (*used only for titling purposes*)
- ⇒ **An “Odometer Disclosure Statement” form** - supplied by General Motors must be signed at the time of the repurchase
- ⇒ **Factory installed equipment** – needs to be intact and functional.
- ⇒ **Title** – if no lien, a free and clear title must be provided at time of repurchase.
- ⇒ **Cash backs rebates or incentives**– no cash backs rebates or incentives of any kind are applicable towards this transaction.

If all above requirements are met, the dealership will proceed with the repurchase and transfer of funds.

Please return this signed document to fax number 866-802-6668 by Thursday July 26, 2018

Sincerely,

General Motors RVDC
2717 Schust Rd
Saginaw, MI 48603

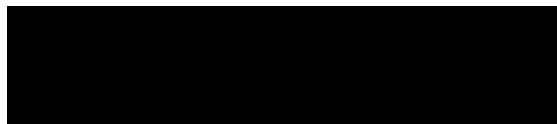

PE18-012

GM

3-27-2019

Q3

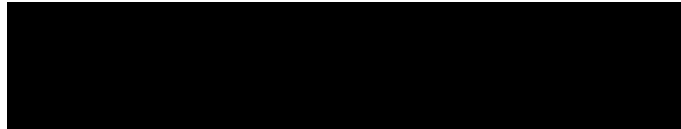





PE18-012

GM

3-27-2019

Q3

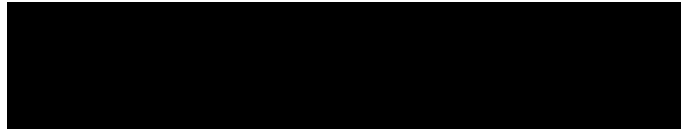

STRAIGHT-PAYMENT-LEASE REPURCHASE WORKSHEET - BRC COMMON

File Number
[REDACTED]

Customer Name
[REDACTED]

Worksheet Filled Out By:
Jair

Tax
3666.48

Draft-Add question marks beside category (not in dollar fields) to indicate incomplete information

Vehicle VIN:

1GTV2UEC3FZ [REDACTED]

Date:

July 12, 2018

USAGE FORMULAS		STRAIGHT REPURCHASE - BASE		PAYMENT (CA, FL & WV) OR LEASE REPURCHASE			
1	Usage	1	Base Price	\$0.00	1	Down Pmt / Cap Cost Reduction	\$500.00
2	Lemon Law usage must be calculated for every case. Only fill out USAGE CHARGED section if case originator instructions differ from LL.	2	Conversion / Upfit cost	\$0.00	2	Pmts (includes 1st month if lease)	\$15,600.00
3		3	Reg./Lic./Title Fees	\$0.00	3	Reg/Lic/Title Fees (leases only)	\$0.00
4		4	State Fees	\$0.00	4	Tax (leases only)	\$0.00
5	USAGE USING LEMON LAW	5	Aftermarket Items	\$0.00	5	Aftermarket Items	\$0.00
6		6	Sales Tax	\$0.00	6	Other-Explain	\$0.00
7	Usage Using Base Price	7	Finance Charges	\$0.00	7	Other-Explain	\$0.00
8	Base Price/Total Repurch Price \$41,710.00	8	GMPP (* only for WI)	\$0.00	8	Other-Explain	\$0.00
9	Mileage 2,246	9	Other-Explain	\$0.00	9	Other-Explain	\$0.00
10	Denominator 120,000	10	Total Purchase Price	\$0.00	10	Total Additions	\$16,100.00
11	Usage \$780.67	11			11		
12		12	* Usage/Depreciation	\$780.67	12	* Usage/Depreciation	\$780.67
13	Usage Using Cents/Mile	13	Damage	\$0.00	13	Damage	\$0.00
14	Mileage 0	14	Late charges	\$0.00	14	Late charges	\$0.00
15	Cents per mile \$0.000	15	Over-Allowance	\$0.00	15	Over-Allowance	\$0.00
16	Usage \$0.00	16	Negative Equity	\$0.00	16	Negative Equity	\$0.00
17		17	Incentives	\$0.00	17	Incentives	\$0.00
18	USAGE CHARGED	18	Other-Explain	\$0.00	18	Surface Protection	\$795.00
19		19	Other-Explain	\$0.00	19	Extended Service Contract	\$2,501.00
20	Usage - Negotiated \$0.00	20	Other-Explain	\$0.00	20	Gap Insurance	\$895.00
21		21	Other-Explain	\$0.00	21	Over Mileage Penalty	\$0.00
22	Usage Using Base Price	22	Total Deductions	\$780.67	22	Total Deductions	\$4,971.67
23	Base Price/Total Repurch Price \$0.00	23			23		
24	Mileage 0	24	Repurchase Subtotal	-\$780.67	24	Total Refund to Customer	\$11,128.33
25	Denominator 100,000	25	Loan Payoff good thru xx/xx/xx	\$0.00	25	Dir Buyout (lease) or Loan Payoff	\$31,145.22
26	Usage \$0.00	26	Total Refund to Customer	-\$780.67	26	(GMAC=DL quote) good thru 08/09/18	
27		27	Attorney's Fees	\$0.00	27	Attorney's Fees	\$0.00
28	Usage Using Cents/Mile	28	Total Repurchase	-\$780.67	28	Total Repurchase	\$42,273.55
29	Mileage 0	29	NADA (Legal Only)	\$0.00	29	NADA (Legal Only)	\$0.00
30	Cents per mile \$0.000	30	Estimated Auction Value	\$0.00	30	Estimated Auction Value	\$0.00
31	Usage \$0.00	31	Projected Loss	-\$780.67	31	Projected Loss	\$42,273.55
		TRADE ALLOWANCE		\$ 500.00	LEMON LAW COMPARISON		
PURCHASE PRICE (before t/t)		MSRP (FROM BARS INVOICE)		\$ 45,710.00	USAGE PER LEMON LAW		
		DIFFERENCE		\$ (4,000.00)	\$ 780.67		
if positive look for over allowance		if negative=negative equity			USAGE CHARGED		
		TRADE ALLOWANCE		\$ 500.00	\$ 780.67		
PURCHASE PRICE		ACV OF TRADE			LEMON LAW VARIANCE		
INCENTIVE* (from BARS)		DIFFERENCE		\$ 500.00	\$ -		
OVERALLOWANCE		ACV=actual cash value					
ACTUAL PRICE							

Pmnts	Mile
12.87	2,276
586.14	30
13.86	2,246
585.15	
14.85	
584.16	
15.84	
583.17	
16.83	
582.18	
17.82	
581.19	
18.81	
580.2	
19.8	
579.21	
20.79	
578.22	
21.78	
577.23	
22.77	
576.24	
23.76	
575.25	
24.75	
574.26	
599.01	
0.99	
598.02	
1.98	
597.03	
2.97	
596.04	
3.96	
595.05	
4.95	
594.06	
5.94	
593.07	
6.93	
592.08	
7.92	
591.09	
8.91	
590.1	
9.9	
589.11	
10.89	

	588.12		
	11.88		
	587.13		
	25.74		
	15600		

PE18-012

GM

3-27-2019

Q3

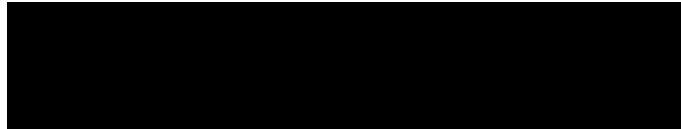

Buyer Name and Address
 Co-Buyer Name and Address
 Seller/Dealer Name and Address

Contract Number
 R.D.S. Number
 Date Number

Year Make and Model
 Year Make and Model
 Year Make and Model

Vehicle Identification Number
 Vehicle Identification Number
 Vehicle Identification Number

Primary Use For Which Purchased
 Personal, family or household use
 Business or commercial

FEDERAL TRUTH-IN-LENDING DISCLOSURES

ANNUAL PERCENTAGE RATE	FINANCE CHARGE	Amount Financed	Total of Payments	Total Sale Price
9.99%	\$540.81	\$3,750.00	\$4,370.81	\$3,750.00

YOUR PAYMENT SCHEDULE WILL BE:

One Payment of	Amount of Payments	When Payments Are Due
\$2	\$59.01	Monthly beginning 05/05/2015
One final payment	\$59.01	DUE ON 04/01/2023

REBATE OF THE AMOUNT FINANCED (seller may keep part of the rebate to pay to others):

- Cash Price Vehicle: \$10,000.00
- Cash Price Accessories: \$100.00
- Other (describe): \$0.00
- Document Processing Charge: \$0.00
- Embossing Sealing Charge: \$0.00
- Optional Theft Deterrent Device: \$0.00
- Optional Theft Deterrent Device (by whom paid): \$0.00
- Optional Theft Deterrent Device (to whom paid): \$0.00
- Optional Surface Protection Product: \$0.00
- EV Charging Station: \$0.00
- State Tax on taxable items: \$0.00
- Electronic Vehicle Registration or Transfer Charge: \$0.00
- Optional Service Contract: \$0.00
- Optional Service Contract: \$0.00
- Optional Service Contract: \$0.00
- Optional Service Contract: \$0.00
- Optional Service Contract: \$0.00
- Optional Service Contract: \$0.00
- Optional Used Vehicle Contract Cancellation Option Agreement: \$0.00

OPTIONAL GAP CONTRACT: A gap contract (also referred to as a "gap" contract) is not required to obtain credit and will not be provided unless you sign below and agree to pay the extra charge. It is provided to help you protect your investment in the event of a total loss of the vehicle. See your contract for details on the terms and conditions of this contract.

OPTIONAL SERVICE CONTRACT: You want to purchase the service contract (written with the following company) for the term: 36 months for the charge shown in Item 11, 12, 13, 14 and/or 15.

HOW THIS CONTRACT MAY BE CANCELLED: This contract contains the entire agreement between you and us relating to this contract. Any change to this contract must be in writing.

SELLER ASSIGNED LEASE: BUYER MAY BE REQUIRED TO PROVIDE SECURITY FOR THE LEAN AND WILL BE SUBJECT TO THE RETAIL LEASE AGREEMENT OR OTHER RETAIL INSTALLMENT SALE CONTRACT AND THE LEAN.

AUTO BROKER FEE DISCLOSURE: If this contract reflects the retail sale of a new motor vehicle, the sale is not subject to a fee received by an auto broker from us unless the following box is checked:

Name of auto broker receiving fee, if applicable.

SELLER'S INITIALS: [Redacted]

BUYER SIGNATURE: [Redacted]

CO-BUYER SIGNATURE: [Redacted]

NOT HAVE FULL COVERAGE. SUPPLEMENTAL COVERAGE FOR COLLISION DAMAGE MAY BE AVAILABLE TO YOU THROUGH YOUR INSURANCE AGENT OR THROUGH THE SELLER. HOWEVER, UNLESS OTHERWISE SPECIFIED, THE COVERAGE YOU OBTAIN THROUGH THE SELLER PROTECTS ONLY THE DEALER, USUALLY UP TO THE AMOUNT OF THE UNPAID BALANCE REMAINING AFTER THE VEHICLE HAS BEEN REPOSSESSED AND SOLD.

FOR PROTECTION OF YOUR INTERESTS, IN THE EVENT OF LOSS OR DAMAGE TO YOUR VEHICLE, YOU SHOULD CONTACT YOUR INSURANCE AGENT. THIS CONTRACT IS SUBJECT TO THE TERMS AND CONDITIONS OF THE SELLER'S PUBLIC LIABILITY TERMS AND CONDITIONS.

SSS # [REDACTED] X B/A

Trade-in [REDACTED] The lessor or lessor of your trade-in vehicle to arrive at the payoff amount shown in item (B) of the Itemization of Amount Financed is an estimate.

Seller agrees to pay the payoff amount shown in (B) to the lessor or lessor of the trade-in vehicle, or its designee. If the actual payoff amount is more than the amount shown in (B), you must pay the Seller the excess amount. Seller will refund to you any overage Seller receives from your prior lessor or lessor. Except as stated in the "NOTICE" or the back of this contract, you will pay the Payor Check or Lease Balance shown in (B) or any refund.

Buyer Signature X [REDACTED] Co-Buyer Signature X [REDACTED]

Notice to buyer: (1) You must read it or it contains any blank spaces to be filled in. (2) You are entitled to a completely filled in copy of this agreement. (3) You can prepay any net amount due under this agreement at any time. (4) If you default in the performance of your obligations under this agreement, the vehicle may be repossessed and you may be subject to suit and liability for the unpaid indebtedness evidenced by this agreement.

Alter this contract in writing. All changes, amendments, or payment terms unless you agree in writing to the change. You do not have to agree to any change, and it is an unfair or deceptive trade practice.

Buyer Signature X [REDACTED] Co-Buyer Signature X [REDACTED]

The Annual Percentage Rate (APR) is [REDACTED]. This contract is not negotiable with the Seller. The Seller may assign this contract and retain its right to receive a part of the Finance Charge.

YOU AGREE TO THE TERMS OF THIS CONTRACT. YOU

THERE IS NO COOLING-OFF PERIOD UNLESS YOU OBTAIN A CONTRACT CANCELLATION OPTION



PE18-012

GM

3-27-2019

Q3

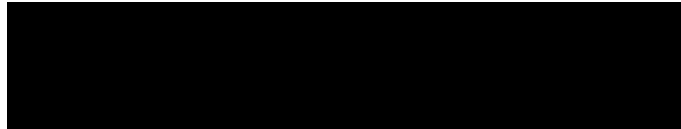

Dealer Notification

Case Number: [REDACTED] Activity Owner: TOCAMPO1

ACTIVITY INFORMATION

Status: Done Created By: GZ4X1H
Contact: Luis Martinez Created: 03/12/2018
End Date:

Documentation Required for CA CEC [REDACTED]

I am requesting information from you. Please reply within 1 business day. This is a request for documentation only. Please do not reach out to the customer at this time. We have received a CA CEC case that pertains to one of our mutual customers. Please provide the following documentation: All sales, purchase and finance agreements, including a conversion invoice (if applicable) The incentives acknowledgement form Copy of the Title and Registration The Actual Cash Value statement of any trade All service and body shop repair orders including all internal, customer pay, and warranty repair orders. (Please include copies of both front and back of the documents). Please confirm if you are aware of any accidents or aftermarket modifications Please provide the needed information within 24 hours. Please provide documentation by attaching through the DCM tool, or sending to fax #586-920-0675. Please be aware there is a 10MB limit so documents may need to be uploaded in multiple uploads. Your cooperation in this matter is greatly appreciated as we are under strict timelines to respond to this matter. Thank you Ariana BRC CA CEC 1-866-790-5600 ext 5913743



GREENWOOD CHEVROLET
270 SAN FELIPE ROAD • HOLLISTER • CA 95023
www.greenwoodmotors.com
831.637.5328

NOTICE TO CONSUMER: PLEASE READ IMPORTANT WARRANTY INFORMATION ON BACK.

BAR # ARD214044

EPA # CAR 000240804

Customer information form including fields for Customer No., Advisor (Roger Dutra), Mileage (5,570), Invoice Date (03/15/18), and Vehicle I.O. No. (1GTV2UEC3FZ).

LABOR -

Table with columns: TECH#, DATE, START, FINISH, ACT, TIME, DESCRIPTION. Includes entries for HOLD OTHER, FINISHED, and OVERRIDE IN INVOICING.

OWNER REPORTS SERVICE BRAKE ASSIST MESSAGE TO BE ON & WHEN APPLYING BRAKE WILL NOTICE BRAKE PEDAL TO TRAVEL ABNORMALLY (FEELS LOWER). CHECK & ADVISE...

RESTARTED VEHICLE 3/8/18 & ALL NORMAL

Table with columns: QTY, FP-NUMBER, DESCRIPTION, U/COST, E/COST, U/PRICE. Includes entry for BOOSTER 4.805.

Table with columns: CODE, DESCRIPTION, CONTROL NO. Includes entry for SH SERVICE SHUTTLE.

TOTALS table showing Labor (167.56), Parts (111.24), Misc (15.00), and Job# 1 Journal Prefix CWS Job# 1 Total (293.80).

COMMENTS: TECH TO ROAD TEST WITH CUSTOMER. R/O TAX 0.00, R/O TOTALS 293.80.

MAR 15 PAID

WARRANTY CLAIM DETAIL TOTALS table showing Claim# and Total (293.80).



GREENWOOD CHEVROLET
270 SAN FELIPE ROAD • HOLLISTER • CA 95023
www.greenwoodmotors.com
831.637.5328

NOTICE TO CONSUMER: PLEASE READ IMPORTANT WARRANTY INFORMATION ON BACK.

BAR # ARD214044

EPA # CAR 000240804

CUSTOMER NO.	ADVISOR	TAG NO.	INVOICE DATE	INVOICE NO.
[REDACTED]	ROGER DUTRA	344	03/15/18	[REDACTED]
[REDACTED]	VEHICLE NO.	MILEAGE	COLOR	ORDER NO.
[REDACTED]	[REDACTED]	5,570	BRONZE/	[REDACTED]
[REDACTED]	YEAR / MAKE / MODEL	DELIVERY DATE	DELIVERY MILES	
[REDACTED]	15/GMC/SIERRA 1500/EXT CAB 4WD 143.5	03/21/16	30	
[REDACTED]	VEHICLE I.D. NO.	SELLING DEALER NO.	PRODUCTION DATE	
[REDACTED]	1 G T V 2 U E C 3 F Z	[REDACTED]		
[REDACTED]	F.T.E. NO.	R.O. NO.	R.O. DATE	
[REDACTED]			03/05/18	
PHONE	COMMENTS			MO: 5575

APPROVED BY SIGNATURE



GREENWOOD CHEVROLET
 270 SAN FELIPE ROAD • HOLLISTER • CA 95023
 www.greenwoodmotors.com
 831.637.5328

NOTICE TO CONSUMER: PLEASE READ IMPORTANT WARRANTY INFORMATION ON BACK.

BAR # ARD214044

EPA # CAR 00240804

CUSTOMER NO.	ADVISOR ROGER DUTRA	TAG NO. 344	INVOICE DATE 03/15/18	INVOICE NO.
	LICENSE NO.	MILEAGE 5,570	COLOR BRONZE/	STOCK NO.
	YEAR / MAKE / MODEL 15/GMC/SIERRA 1500/EXT CAB 4WD 143.5		DELIVERY DATE 03/21/16	DELIVERY MILES 30
	VEHICLE ID. NO. 1GTV2UEC3FZ		SELLING DEALER NO.	PRODUCTION DATE
	F.T.E. NO.	P.O. NO.	R.O. DATE 03/05/18	
COMMENTS				MO: 5575

DCS AUDIT SLIP

JOB CARD [REDACTED]

VIN 1GTV2UEC3FZ [REDACTED] REPAIRING BAC 172 [REDACTED]
 ODOMETER INDICATOR M JOB CARD OPEN DATE 03/05/2018
 ODOMETER 5570 SERVICE ADVISOR GMIN 985894283
 NON-GM VEHICLE N FOREIGN TOURIST
 REFERENCE NUMBER [REDACTED]

JOB	PAY TYPE	TRANS TYPE	CATEGORY	ERA CLAIM#	OEM SAP TRAN.#	VER
1	W	ZREG		[REDACTED]		

JOB COMPLETION DATE: 03/07/2018
 TECHNICIAN GMIN: 743713683

LABOR OPERATION BASE HOURS
 2441580 1.3

OTHER LABOR OPS (Y/N) N

COMPLAINT CODE: 0131
 COMPLAINT DESCRIPTION: OWNER REPORTS SERVICE BRAKE ASSIST MESSAGE TO BE ON & WHEN APPLYING BRAKE WILL NOTICE BRAKE PEDAL TO TRAVEL ABNORMALLY (FEELS ELS LOWER).CHECK & ADVISE

CAUSE CODE: 6571
 CAUSE DESCRIPTION: SCANNED SYSTEM CODES C025E-05 AND C025E-5A STORED IN HIS TORY AGAIN.CALLED TECH STILL OPEN CASE [REDACTED] SPOKE WITH COREY WENT ENT THROUGH BRAKE SYSTEM VACUUM SOURCE TEST DOC# 4247767.OUT COME VEHICLE CLE IS ALL WITH IN SPECT OF 27inHG AT THIS POINT WAS TOLD TO REPLACE THE B HE BRAKE BOOSTER UNIT

CORRECTION DESCRIPTION: REMOVED AND REPLACED THE BRAKE BOOSTER UNIT CLEARED STORED DTCs TEST DROVE OK. , RESTARTED VEHICLE 3/8/18 & ALL NORMAL

CAUSAL PART: 23135220

PART NUMBER	QTY	UNIT COST	REPLACEMENT SERIAL#	TRADE	NON-GM
23135220	1	79.46			

NET AMOUNT	CODE	INVOICE NO.	DISTANCE	RENTAL VIN OR INFO	DAYS	REASON
15.00	NS2					

WAIVE DEDUCTIBLE (Y/N) N

	TOTAL W/O TAX	TAX	TOTAL
PARTS HANDLING	31.78		
PARTS	79.46	0.00	111.24
LABOR	167.56	0.00	167.56
NET ITEMS	15.00	0.00	15.00
PARTICIPATION AMOUNT			(0.00)
TRANSACTION	293.80	0.00	293.80



GREENWOOD CHEVROLET
270 SAN FELIPE ROAD • HOLLISTER • CA 95023
www.greenwoodmotors.com
831.637.5328

NOTICE TO CONSUMER: PLEASE READ IMPORTANT WARRANTY INFORMATION ON BACK.

BAR # ARD214044

EPA # CAR 000240804

Customer information form including fields for Customer No., Advisor (Roger Dutra), Tag No. (344), Invoice Date (03/08/18), Invoice No., Mileage (5,570), Year/Make/Model (15/GMC/SIERRA 1500/EXT CAB 4WD 143.5), Delivery Date (03/21/16), Delivery Miles (30), Vehicle I.D. No. (1GTV2UEC3FZ), F.T.E. No., P.O. No., R.O. Date (03/05/18), and Comments.

MO: 5575

JOB# 1 CHARGES

LABOR
JOB# 1 09CVZ ELECTRICAL TECH(S):167 WARRANTY

OWNER REPORTS SERVICE BRAKE ASSIST MESSAGE TO BE ON & WHEN APPLYING BRAKE WILL NOTICE BRAKE PEDAL TO TRAVEL ABNORMALLY (FEELS LOWER).CHECK & ADVISE SCANNED SYSTEM CODES C025E-05 AND C025E-5A STORED IN HISTORY AGAIN.CALLED TECH STILL OPEN CASE SPOKE WITH COREY WENT THROUGH BRAKE SYSTEM VACUUM SOURCE TEST DOC# 4247767.OUT COME VEHICLE IS ALL WITH IN SPECT OF 27inhg AT THIS POINT WAS TOLD TO REPLACE THE BRAKE BOOSTER UNIT REMOVED AND REPLACED THE BRAKE BOOSTER UNIT CLEARED STORED DTCs TEST DROVE OK.

RESTARTED VEHICLE 3/8/18 & ALL NORMAL

MAR 08 2018

Table with columns: PARTS, QTY, FP-NUMBER, DESCRIPTION, UNIT PRICE, WARRANTY. Row 1: 1, 23135220, BOOSTER 4.805, TOTAL - PARTS 0.00

JOB# 1 TOTALS
JOB# 1 JOURNAL PREFIX CVCS JOB# 1 TOTAL 0.00

COMMENTS
TECH TO ROAD TEST WITH CUSTOMER

TOTALS section with payment options (CASH, CHECK, VISA, MASTERCARD, DISCOVER, AMER EXPRESS, OTHER, CHARGE) and a summary of charges: TOTAL LABOR 0.00, TOTAL PARTS 0.00, TOTAL SUBLET 0.00, TOTAL G.O.G. 0.00, TOTAL MISC CHG. 0.00, TOTAL MISC DISC 0.00, TOTAL TAX 0.00, TOTAL INVOICE \$ 0.00

THANK YOU FOR YOUR BUSINESS !!
#1 GOAL.
ERSHIP.

19. If any of these conditions were found with the check valve grommet, replace the grommet.

Document ID: 4247767

Brake System Vacuum Source Test

Note:

- Engine temperature, accessory load, and elevation level will affect engine vacuum.
- Vacuum readings will decrease by approximately 2.7 kPa (0.8 in Hg) (0.39 psi) for every 305 m (1000 ft) of elevation above sea level.

1. Disconnect the engine vacuum hose from the vacuum brake booster check valve.

Note: The vacuum information can be verified using a scan tool to obtain the data from the electronic brake control module (EBCM).

2. Install a vacuum gauge to the engine vacuum hose.
3. Start the engine and allow the engine to idle until normal operating temperatures are reached.
4. With the vehicle in PARK, the engine idling, and the air conditioning (A/C) system OFF, check to see if the engine vacuum reading is within the specified normal engine vacuum range.

Specification

Specification 90 kPa (27 in Hg) (13 psi)

5. Turn the ignition OFF.
 6. If the engine vacuum reading was within the specified normal range, proceed to step 10.
 7. If the engine vacuum reading was NOT within the specified normal range, inspect the engine vacuum hose for the following conditions:
 - Loose connection at the vacuum source
 - Collapse, deformation or contamination
 - Cracks, cuts, dry-rot
 8. If any of these conditions were found with the engine vacuum hose, replace the hose, then repeat steps 2–4.
 9. If none of these conditions were found with the engine vacuum hose, then there is an engine vacuum source problem, check the engine vacuum system.
 10. Remove the vacuum brake booster check valve from the booster.
 11. Install the check valve to the engine vacuum hose.
- Note:** The vacuum information can be verified using a scan tool to obtain the data from the EBCM.
12. Install the vacuum gauge to the check valve.
 13. Start the engine and allow the engine to idle in PARK with the A/C system OFF, until normal operating temperatures are reached.
 14. Turn the ignition OFF.
 15. Check to see if the engine vacuum reading is maintained within the specified normal engine vacuum range.

Specification

Specification 90 kPa (27 in Hg) (13 psi)

16. If the engine vacuum reading is maintained within the specified normal range, proceed to step 18.
17. If the engine vacuum reading is NOT maintained within the specified normal range, replace the brake booster check valve, then repeat steps 11–15.
18. Inspect the brake booster check valve grommet for the following conditions:
 - Loose connection to the vacuum brake booster
 - Deformation or contamination
 - Cracks, cuts, dry-rot

Control
Module

This
Ignition
Cycle
DTC
Current
Status Not
Current
DTC
History
Status History
MIL
Status Not
Requested

History
This
Ignition
Cycle Not
Run

Electronic
Brake
Control
Module

C025E 5A

Brake Booster
Vacuum Sensor Not Plausible
Circuit

DTC
Current
Status Not
Current
DTC
History
Status History
MIL
Status Not
Requested





Global Diagnostic System 2

DTC Display

Overview

Vehicle Identification Number (VIN) 1GTV2UEC3FZ [REDACTED]
 Report Creation Date 2018-03-05 15:15:24 PST

Vehicle Configuration Property

Make GMC
 Model Sierra
 Model Year 2015
 Chassis Control Module Version Trailer Brake Control
 Passenger Presence System Version Passenger Presence System (AL0)
 Telematics Communication Interface Control Module Version 10
 Transmission Type Automatic Transmission 6 Speed (MYC)
 Seat Memory Control Module Version Not Equipped
 Transfer Case Control Module Version Transfer Case, Two Speed, Switch Activated (NQH)
 Engine Identifier 5.3L (L83)

System Information Property

VCI Serial Number MDI [REDACTED]
 Vehicle Session Creation Date 2017-03-09 13:47:14
 Test Start Time 2018-03-05 15:15:07 PST

Control Module Name	Control Module Status	DTC Count	DLC Pin
Electronic Brake Control Module	DTCs Stored	2	6,14

Control Module	DTC Display	Symptom Byte	DTC Description	Symptom Description	Status
Electronic Brake	C025E	06	Brake Booster Vacuum Sensor Circuit	Low Voltage/Open	History Passed



✓	GMC 2 Year Scheduled Maintenance	03/21/2016	49 MI	03/21/2018	24,049 MI
✓	Emission Select Component Ltd Wty	03/21/2016	49 MI	03/21/2024	80,049 MI
✓	Emission Limited Warranty	03/21/2016	49 MI	03/21/2019	50,049 MI
✓	Bumper to Bumper Limited Warranty	03/21/2016	49 MI	03/21/2019	36,049 MI

Service Contract

Vehicle has no current record of service contracts.

Transaction History

[View Details](#)

Job Card Date	Job Card Number	Transaction Type	Transaction Adjustment	Labour Operation	Odometer Reading
02/20/2018		ZREG---Regular Vehicle Transaction		0600743 - GMC 2 Year Maintenance	5,360 MI
08/07/2017		ZREG---Regular Vehicle Transaction		4023850 - Vacuum Pump Assembly Replacement	4,189 MI
06/19/2017		ZREG---Regular Vehicle Transaction		2410370 - Electronic Brake Control Module Replacement	3,591 MI
03/13/2017		ZREG---Regular Vehicle Transaction		5430840 - Terminal Replacement	2,743 MI
12/22/2016		ZREG---Regular Vehicle Transaction		2441640 - Power Brake Booster Vacuum Pipe Replacement	2,276 MI
10/03/2016		ZFAT---Field Action Recall		9102276 - 16007 - N16-204817 - Reprogram Inflatable Restraint Sensing and Diagnostic Module Calibrations	1,744 MI
07/10/2015		ZPDI---Pre-Delivery Inspection		0590032 - PDI - Dealer Installed - Factory Invoiced Options	2 MI
06/18/2015		ZPDI---Pre-Delivery Inspection		0590072 - Pre-Delivery Inspection - Base Time	1 MI

Global Warranty Management Site Map

[Privacy Policy](#) | [Terms of Use](#)

© 2005 General Motors. All rights reserved.



Connect

Roger Dutra

[Update My Profile](#)
[Logout](#)

March 5, 2018

Global Warranty Management: Main > Interface With Customer > View Vehicle Summary

INTERFACE WITH
CUSTOMER

View Vehicle Summary

This screen allows IVH users to view the Summary of Vehicle Information, Field Actions, Service Information, Applicable Warranties, Transaction History, Service Contract(s) if applicable, Warranty Block, Branded Title information and OnStar and XM Radio information (if applicable)

For this vehicle:

- [View Vehicle Summary](#)
- [Service Contract](#)
- [Branded Title](#)
- [Warranty Block](#)
- [View Vehicle Build](#)
- [View Vehicle Component Summary](#)
- [View Vehicle Transaction History Detail](#)
- [View Vehicle Delivery Information](#)
- [Investigate Major Assembly History](#)

Vehicle Information

VIN: 1GTV2UEC3FZ [REDACTED] Model: TK15753-2015 SIERRA 1500 4WD DOUBLE CAB
 Service Contract: No Branded Title: No Warranty Block: No PDI Status: Yes
 Order Type: 70 - RETAIL - STOCK
 Field Actions: [0 Open](#) [REQUEST ANOTHER VIN](#)

Required Field Actions

Open Field Action Details are highlighted

Type	Number	Original Nbr	Description	Release Date	Status
Product Safety Recall	[REDACTED]	[REDACTED]	Frontal Airbag And Pretensioner Non Deploy	09/08/2016	Closed

Branded Title

*The VIN information contained herein and information derived therefrom is the proprietary property of The Polk Company and is to be used only for the purpose of warranty verification and shall not be used for any other purpose whatsoever.

Vehicle has no current record of branded titles.

Warranty Block

Vehicle has no current record of warranty block.

Service Information

Vehicle has no current record of outstanding service information.

OnStar and XM Satellite Radio Information

Refer to Help page for details. For OnStar contact 888.ON.STAR1 (888.667.8271) and for XM Radio contact 877.GET.XMST (877.438.9677 Canada) and in the USA: 800-556-3600.

OnStar Equipped: Y OnStar Status: Active
 XM Equipped: Y XM Radio ID: 6HLYD3RV XM Status: Active
 OnStar Vehicle Diagnostics: Y DMN Enabled: Y

Applicable Warranties

Valid warranties are highlighted

Valid	Description	Start Date	Effective Odometer	End Date	End Odometer
✓	Powertrain Limited Warranty	03/21/2016	49 MI	03/21/2021	100,049 MI
✓	Emission Select State Component Ltd Wty	03/21/2016	49 MI	03/21/2023	70,049 MI
✓	Corrosion Limited Warranty	03/21/2016	49 MI	03/21/2022	100,049 MI



GREENWOOD CHEVROLET BUICK GMC

270 SAN FELIPE ROAD • HOLLISTER • CA 95023

www.greenwoodmotors.com

831.637.5328

NOTICE TO CONSUMER: PLEASE READ IMPORTANT WARRANTY INFORMATION ON BACK.

BAR # ARD214044

EPA # CAR 000240804

CUSTOMER NO.	ADVISOR CARLOS MIRANDA	TAG NO. 298	INVOICE DATE 08/11/17	INVOICE NO.
	LICENSE NO.	MILEAGE 4,189	COLOR BRONZE/	STOCK NO.
	YEAR / MAKE / MODEL 15/GMC/SIERRA 1500/EXT CAB 4WD 143.5		DELIVERY DATE 03/21/16	DELIVERY MILES 30
	VEHICLE I.D. NO. 1 G T V 2 U E C 3 F Z		SELLING DEALER NO.	PRODUCTION DATE
	F.T.E. NO.	P.O. NO.	R.O. DATE 08/07/17	
BUSINESS PHONE	COMMENTS			MO: 4224

JOB# 1 CHARGES-----

LABOR-----
 J# 1 09CVZ ELECTRICAL HOURS: 2.00 TECH(S): 167 251.50

TECH#	DATE	START	FINISH	ACT	TIME	DESCRIPTION
167	08/07/17	16.10	16.50	0.40	0.00	HOLD OTHER
167	08/08/17	10.00	11.00	1.00	0.00	HOLD OTHER
167	08/08/17	11.00	11.50	0.50	0.00	HOLD OTHER
167	08/08/17	12.10	12.40	0.30	0.00	HOLD OTHER
167	08/09/17	15.30	16.70	1.40	0.00	HOLD OTHER
167	08/10/17	12.40	12.70	0.30	0.00	FINISHED
167	08/11/17	0.00	0.00	0.00	2.00	OVERRIDE IN INVOICING
TOTAL TECH TIME				3.90	2.00	

OWNER REPORTS SERVICE BRAKE ASSIST MESSAGE TO BE ON.
 CODES SCANNED & C025E-06 WAS PRESENT AGAIN. CHECK & ADVISE
 CALL TACH CASE [REDACTED] SPOKE WITH AARON. PERFORMED A
 FEW TESTS AND AT THIS POINT TO REPLACE THE VACUUM PUMP
 REMOVED AND REPLACED THE PUMP TEST DROVE LONG DISTANCE
 NO EVENT

PARTS	QTY	FP-NUMBER	DESCRIPTION	U/COST	E/COST	U/PRICE	
	1	12669488	PUMP 3.280	121.06	121.06	169.48	169.48
COST TOTAL					121.06		
TOTAL - PARTS							169.48

JOB# 1 TOTALS-----
 LABOR 251.50
 PARTS 169.48

JOB# 1 JOURNAL PREFIX CVWS JOB# 1 TOTAL 420.98

COMMENTS-----
 EARLY BIRD
 R/O TAX 0.00
 R/O TOTALS 420.98

AUG 1 1 PAID

WARRANTY CLAIM DETAIL TOTALS-----

CLAIM#	TOTAL
[REDACTED]	420.98
CLAIM TOTALS	420.98

APPROVED BY SIGNATURE



GREENWOOD CHEVROLET BUICK GMC

270 SAN FELIPE ROAD • HOLLISTER • CA 95023

www.greenwoodmotors.com

831.637.5328



NOTICE TO CONSUMER: PLEASE READ IMPORTANT WARRANTY INFORMATION ON BACK.

BAR # ARD214044

EPA # CAR 000240804

CUSTOMER NO.	ADVISOR CARLOS MIRANDA	TAG NO. 298	INVOICE DATE 08/11/17	INVOICE NO.
	LICENSE NO.	MILEAGE 4,189	COLOR BRONZE/	STOCK NO.
	YEAR / MAKE / MODEL 15/GMC/SIERRA 1500/EXT CAB 4WD 143.5		DELIVERY DATE 03/21/16	DELIVERY MILES 30
	VEHICLE I.D. NO. 1GTV2UEC3FZ		SELLING DEALER NO.	PRODUCTION DATE
	F.T.E. NO.	R.C. NO.	R. Q. DATE 08/07/17	
PHONE	COMMENTS			

MO: 4224

DCS AUDIT SLIP

JOB CARD
 VIN 1GTV2UEC3FZ
 ODOMETER INDICATOR M
 ODOMETER 4189
 NON-GM VEHICLE N
 REFERENCE NUMBER
 REPAIRING BAC 172
 JOB CARD OPEN DATE 08/07/2017
 SERVICE ADVISOR GMIN 570709628
 FOREIGN TOURIST

JOB	PAY TYPE	TRANS TYPE	CATEGORY	ERA CLAIM#	OEM SAP TRAN.#	VER
1	W	ZREG				

JOB COMPLETION DATE: 08/10/2017
 TECHNICIAN GMIN: 743713683

LABOR OPERATION	BASE HOURS	DIAGNOSIS	OTHER
4023850	1.2	.3	.5

OTHER LABOR OPS (Y/N) N

COMPLAINT CODE: 0621

COMPLAINT DESCRIPTION: OWNER REPORTS SERVICE BRAKE ASSIST MESSAGE TO BE ON. CODES SCANNED & C025E-06 WAS PRESENT AGAIN,CHECK & ADVISE

CAUSE CODE: 6571

CAUSE DESCRIPTION: CALL TACH CASE # SPOKE WITH AARON.PERFORMED A FEW TESTS AND AT THIS POINT TO REPLACE THE VACUUM PUMP

CORRECTION DESCRIPTION: REMOVED AND REPLACED THE PUMP TEST DROVE LONG DISTANCE NO EVENT

CAUSAL PART: 12669488

PART NUMBER	QTY	UNIT COST	REPLACEMENT SERIAL#	TRADE	NON-GM
12669488	1	121.06			

SERVICE MANAGEMENT AUTHORIZATION CODE: E
 REASON FOR AUTHORIZATION: OLH FOR TESTING PER TAC

WAIVE DEDUCTIBLE (Y/N) N

	TOTAL W/O TAX	TAX	TOTAL
PARTS HANDLING	48.42		
PARTS	121.06	0.00	169.48
LABOR	251.50	0.00	251.50
NET ITEMS	0.00	0.00	0.00
PARTICIPATION AMOUNT			(0.00)
TRANSACTION	420.98	0.00	420.98



GREENWOOD CHEVROLET BUICK GMC

270 SAN FELIPE ROAD • HOLLISTER • CA 95023

www.greenwoodmotors.com

831.637.5328



NOTICE TO CONSUMER: PLEASE READ IMPORTANT WARRANTY INFORMATION ON BACK.

BAR # ARD214044

EPA # CAR 000240804

CUSTOMER NO.	ADVISOR CARLOS MIRANDA	298	TAG NO.	INVOICE DATE 08/10/17	INVOICE NO.
	LICENSE NO.		MILEAGE 4,189	COLOR BRONZE/	STOCK NO.
	YEAR / MAKE / MODEL 15/GMC/SIERRA 1500/EXT CAB 4WD 143.5			DELIVERY DATE 03/21/16	DELIVERY MILES 30
	VEHICLE I.D. NO. 1 G T V 2 U E C 3 F Z			SELLING DEALER NO.	PRODUCTION DATE
	F.T.E. NO.		P.O. NO.	R.O. DATE 08/07/17	
SS PHONE	COMMENTS				MO: 4224

JOB# 1 CHARGES

LABOR
JOB# 1 09CVZ ELECTRICAL TECH(S):167 WARRANTY

OWNER REPORTS SERVICE BRAKE ASSIST MESSAGE TO BE ON. CODES SCANNED & C025E-06 WAS PRESENT AGAIN,CHECK & ADVISE CALL TACH CASE SPOKE WITH AARON.PERFORMED A FEW TESTS AND AT THIS POINT TO REPLACE THE VACUUM PUMP REMOVED AND REPLACED THE PUMP TEST DROVE LONG DISTANCE NO EVENT

PARTS	QTY	FP-NUMBER	DESCRIPTION	UNIT PRICE	WARRANTY
	1	12669488	PUMP 3.280		
TOTAL - PARTS					0.00

JOB# 1 TOTALS
JOB# 1 JOURNAL PREFIX CVCS JOB# 1 TOTAL 0.00

COMMENTS
EARLY BIRD

TOTALS

*****		TOTAL LABOR....	0.00
* [] CASH [] CHECK CHECK # []		TOTAL PARTS....	0.00
* [] VISA [] MASTERCARD [] DISCOVER		TOTAL SUBLET...	0.00
* [] AMER EXPRESS [] OTHER [] CHARGE		TOTAL G.O.G....	0.00
*****		TOTAL MISC CHG.	0.00
		TOTAL MISC DISC	0.00
		TOTAL TAX.....	0.00
		TOTAL INVOICE \$	0.00

THANK YOU FOR YOUR BUSINESS !!

GOAL.
IP.

↓ **If less than 2 Ω**

10. Test or replace the B19B Brake Booster Vacuum Sensor.

Repair Instructions

Perform the Diagnostic Repair Verification after completing the repair.

- Power Brake Booster Vacuum Sensor Replacement
- Control Module References for electronic brake control module replacement, programming and setup

1. Ignition OFF and all vehicle systems OFF, disconnect the harness connector at the B19B Brake Booster Vacuum Sensor. It may take up to 2 min for all vehicle systems to power down.
2. Test for less than 10 Ω between the low reference circuit terminal 2 and ground.
 - ⇒ **If 10 Ω or greater**
 - 2.1. Disconnect the harness connector at the K17 Electronic Brake Control Module.
 - 2.2. Test for less than 2 Ω in the low reference circuit end to end.
 - ⇒ If 2 Ω or greater, repair the open/high resistance in the circuit.
 - ⇒ If less than 2 Ω , replace the K17 Electronic Brake Control Module.
 - ↓ **If less than 10 Ω**
3. Ignition ON.
4. Test for 4.8–5.2 V between the 5 V reference circuit terminal 3 and ground.
 - ⇒ **If less than 4.8 V**
 - 4.1. Ignition OFF, disconnect the harness connector at the K17 Electronic Brake Control Module.
 - 4.2. Test for infinite resistance between the 5 V reference circuit and ground.
 - ⇒ If less than infinite resistance, repair the short to ground on the circuit.
 - ↓ If infinite resistance
 - 4.3. Test for less than 2 Ω in the 5 V reference circuit end to end.
 - ⇒ If 2 Ω or greater, repair the open/high resistance in the circuit.
 - ⇒ If less than 2 Ω , replace the K17 Electronic Brake Control Module.
 - ⇒ **If greater than 5.2 V**
 - 4.1. Ignition OFF, disconnect the harness connector at the K17 Electronic Brake Control Module, ignition ON.
 - 4.2. Test for less than 1 V between the 5 V reference circuit and ground.
 - ⇒ If 1 V or greater, repair the short to voltage on the circuit.
 - ⇒ If less than 1 V, replace the K17 Electronic Brake Control Module.
 - ↓ **If between 4.8–5.2 V**
5. Ignition OFF, disconnect the harness connector at the K17 Electronic Brake Control Module, Ignition ON.
6. Test for less than 1 V between the B19B Brake Booster Vacuum Sensor signal circuit terminal 1 and ground.
 - ⇒ **If greater than 1 V**

Repair the short to voltage on the circuit.
 - ↓ **If less than 1 V**
7. Ignition OFF.
8. Test for infinite resistance between the B19B Brake Booster Vacuum Sensor signal circuit terminal 1 and ground.
 - ⇒ **If less than infinite resistance**

Repair the short to ground on the circuit.
 - ↓ **If infinite resistance**
9. Test for less than 2 Ω between the B19B Brake Booster Vacuum Sensor signal circuit terminal 1 and the K17 Electronic Brake Control Module signal circuit terminal 34.
 - ⇒ **If 2 Ω or greater**

Repair the open/high resistance in the circuit.

C025E 06

- An open/high is detected on the signal circuit.
- A short to ground is detected on the signal circuit.
- An open/high is detected on the 5V reference circuit.

C025E 1F

The vacuum sensor signal is erratic.

C025E 5A

The vacuum sensor signal is not plausible.

Action Taken When the DTC Sets

Service Brake Assist message is displayed on the driver information center

Conditions for Clearing the DTC

The DTC clears when the diagnostic runs and passes

Reference Information**Schematic Reference**

Hydraulic Brake Schematics

Connector End View Reference

Component Connector End Views

Description and Operation

Brake Assist System Description and Operation

Electrical Information Reference

- Circuit Testing
- Connector Repairs
- Testing for Intermittent Conditions and Poor Connections
- Wiring Repairs

DTC Type Reference

Powertrain Diagnostic Trouble Code (DTC) Type Definitions

Scan Tool Reference

Control Module References for scan tool information

Circuit/System Verification

1. Verify that the brake booster vacuum system has no damage, leakage or incorrect installation.
⇒ **If damage, leakage or incorrect installation is found**
Refer to Brake Assist System Diagnosis
↓ **If no damage, leakage or incorrect installation is found**
2. Refer to Circuit/System Testing.

Circuit/System Testing

DTC C025E

Diagnostic Instructions

- Perform the Diagnostic System Check - Vehicle prior to using this diagnostic procedure.
- Review Strategy Based Diagnosis for an overview of the diagnostic approach.
- Diagnostic Procedure Instructions provides an overview of each diagnostic category.

DTC Descriptor

DTC C025E Brake Booster Vacuum Sensor Circuit

For symptom byte information refer to Symptom Byte List.

Diagnostic Fault Information

Circuit	Short to Ground	Open/High Resistance	Short to Voltage	Signal Performance
5V Reference	C025E 00	C025E 06	C025E 00	—
Sensor Signal	C025E 06	C025E 06	C025E 01	C025E 1F, C025E 5A
Low Reference	—	C025E 01	—	—

Circuit/System Description

The brake booster vacuum sensor monitors the pressure in the brake booster. The electronic brake control module supplies a 5V reference and a low reference circuit to the brake booster vacuum sensor. The vacuum sensor supplies a voltage signal in relation to the pressure in the brake booster to the electronic brake control module.

Conditions for Running the DTC

C025E 00, C025E 01, C025E 06, C025E 1F

Ignition ON

C025E 5A

- Ignition ON.
- Brakes are not applied.

Conditions for Setting the DTC

C025E 00

- A short to ground is detected on the 5V reference circuit.
- A short to voltage is detected on the 5V reference circuit.

C025E 01

- A short to voltage is detected on the signal circuit.
- An open/high resistance is detected on the low reference circuit.

Number of Times DTC has Occurred Since DTCs Cleared	Electronic Brake Control Module	2	Counts
Secondary Code of DTC	Electronic Brake Control Module	0	
Antilock Braking System Status	Electronic Brake Control Module	Inactive	
Traction Control System Status	Electronic Brake Control Module	Inactive	
Vehicle Stability System	Electronic Brake Control Module	Inactive	
Dynamic Rear Proportioning Status	Electronic Brake Control Module	Inactive	
Left Front Wheel Speed Sensor	Electronic Brake Control Module	0	MPH
Right Front Wheel Speed Sensor	Electronic Brake Control Module	0	MPH
Left Rear Wheel Speed Sensor	Electronic Brake Control Module	0	MPH
Right Rear Wheel Speed Sensor	Electronic Brake Control Module	0	MPH
Steering Wheel Angle	Electronic Brake Control Module	0	°
Brake Pressure Sensor	Electronic Brake Control Module	0	kPa
Brake Pedal Position Sensor	Electronic Brake Control Module	Inactive	
Lateral Acceleration	Electronic Brake Control Module	0	g
Longitudinal Acceleration	Electronic Brake Control Module	0	g
Yaw Rate	Electronic Brake Control Module	0	°/s



Global Diagnostic System 2

Freeze Frame/Failure Records

Overview

Vehicle Identification Number (VIN) 1GTV2UEC3FZ [REDACTED]
 Report Creation Date 2017-08-07 16:19:36 PDT

Vehicle Configuration Property

Make GMC
 Model Sierra
 Model Year 2015
 Chassis Control Module Version Trailer Brake Control
 Passenger Presence System Version Passenger Presence System (AL0)
 Telematics Communication Interface Control Module Version 10
 Transmission Type Automatic Transmission 6 Speed (MYC)
 Seat Memory Control Module Version Not Equipped
 Transfer Case Control Module Version Transfer Case, Two Speed, Switch Activated (NQH)
 Engine Identifier 5.3L (L83)

System Information Property

VCI Serial Number MDI [REDACTED]
 Vehicle Session Creation Date 2017-03-09 13:47:14
 Test Start Time 2017-08-07 16:19:02 PDT

Freeze Frame/Failure Records	DTC Display	Symptom Byte	DTC Description	Symptom Description
Freeze Frame	C025E	06	Brake Booster Vacuum Sensor Circuit	Low Voltage/Open
Parameter Name	Control Module	Value	Unit	
Ignition Cycles Since Last DTC	Electronic Brake Control Module	23	Counts	



Control
Module

This
Ignition
Cycle

DTC
Current
Status Not
Current

DTC
History
Status History

MIL
Status Not
Requested





old case



Global Diagnostic System 2

DTC Display

Overview

Vehicle Identification Number (VIN) 1GTV2UEC3FZ [REDACTED]
Report Creation Date 2017-08-07 16:18:46 PDT

Vehicle Configuration Property

Make GMC
Model Sierra
Model Year 2015
Chassis Control Module Version Trailer Brake Control
Passenger Presence System Version Passenger Presence System (AL0)
Telematics Communication Interface Control Module Version 10
Transmission Type Automatic Transmission 6 Speed (MYC)
Seat Memory Control Module Version Not Equipped
Transfer Case Control Module Version Transfer Case, Two Speed, Switch Activated (NQH)
Engine Identifier 5.3L (L83)

System Information Property

VCI Serial Number MDI [REDACTED]
Vehicle Session Creation Date 2017-03-09 13:47:14
Test Start Time 2017-08-07 16:18:35 PDT

Control Module Name	Control Module Status	DTC Count	DLC Pin
Electronic Brake Control Module	DTCs Stored	1	6,14

Control Module	DTC Display	Symptom Byte	DTC Description	Symptom Description	Status
Electronic Brake	C025E	06	Brake Booster Vacuum Sensor Circuit	Low Voltage/Open	History Passed





GREENWOOD CHEVROLET BUICK GMC

270 SAN FELIPE ROAD • HOLLISTER • CA 95023

www.greenwoodmotors.com

831.637.5328



NOTICE TO CONSUMER: PLEASE READ IMPORTANT WARRANTY INFORMATION ON BACK.

BAR # ARD214044

EPA # CAR 000240804

CUSTOMER NO.	ADVISOR ROGER DUTRA	TAG NO. 344	INVOICE DATE 06/28/17	INVOICE NO.
	LICENSE NO.	MILEAGE 3,591	COLOR BRONZE/	STOCK NO.
	YEAR / MAKE / MODEL 15/GMC/SIERRA 1500/EXT CAB 4WD 143.5		DELIVERY DATE 03/21/16	DELIVERY MILES 30
	VEHICLE I.D. NO. 1 GTV 2 UEC 3 EZ		SELLING DEALER NO.	PRODUCTION DATE
	F.T.E. NO.		R.O. DATE 06/19/17	
BUSINESS PHONE	COMMENTS			

MO: 3597

JOB# 1 CHARGES

TECH#	DATE	START	FINISH	ACT	TIME	DESCRIPTION
198	06/20/17	9.20	10.00	0.40	0.00	HOLD OTHER
198	06/20/17	10.00	11.30	0.70	0.00	HOLD OTHER
198	06/20/17	12.00	12.00	0.00	0.00	FINISHED
198	06/23/17	0.00	0.00	0.00	0.90	OVERRIDE IN INVOICING
198	06/28/17	0.00	0.00	0.00	0.40	ENTERED IN INVOICING
TOTAL TECH TIME				1.10	1.30	

OWNER REPORTS SERVICE BRAKE ASSIST MESSAGE TO BE ON. SCANNED CODE ON 6/16/17 C025E-06 WAS PRESENT. CHECK & ADVISE VERIFIED CONCERN. CHK CODES AND FOUND C025E-BRAKE BOOSTER VACUUM SENSOR CIRC. TESTED SYSTEM CIRC AND WAS GOOD. TRACED FAULT TO INTERNAL FAILURE WITH EBCH. REPLACED EBCH, PROGRAMMED AND PERFORMED SET UP/CONFIGURATION PROCEDURES. CLEARED CODES AND TEST DROVE. TESTED GOOD AND CODES DID NOT RESET. CLAIM CODES 28DCD FOR PROGRAMMING, AND S2 A70 FOR SET UP/CONFIG.

PARTS	QTY	FP-NUMBER	DESCRIPTION	U/COST	E/COST	U/PRICE
	1	23154722	MODULE KI 4.720	114.20	114.20	159.88
COST TOTAL				114.20		
TOTAL - PARTS						159.88

JOB# 1 TOTALS

LABOR 163.48
PARTS 159.88

JOB# 1 JOURNAL PREFIX CVWS JOB# 1 TOTAL 323.36

COMMENTS
DROPPING OFR FOR TUESDAY...3RD TIME BACK

R/O TAX 0.00
R/O TOTALS 323.36

JUN 28 PAID

WARRANTY CLAIM DETAIL TOTALS

CLAIM#	TOTAL
	323.36
CLAIM TOTALS	323.36

APPROVED BY SIGNATURE



GREENWOOD CHEVROLET BUICK GMC
 270 SAN FELIPE ROAD • HOLLISTER • CA 95023
www.greenwoodmotors.com
 831.637.5328

NOTICE TO CONSUMER: PLEASE READ IMPORTANT WARRANTY INFORMATION ON BACK.

BAR # ARD214044

EPA # CAR 000240804

CUSTOMER NO. [REDACTED]	ADVISOR ROGER DUTRA	TAG NO. 344	INVOICE DATE 03/30/17	INVOICE NO. [REDACTED]
	LICENSE NO. [REDACTED]	MILEAGE 2,743	COLOR BRONZE/	STOCK NO. [REDACTED]
	YEAR / MAKE / MODEL 15/GMC/SIERRA 1500/EXT CAB 4WD 143.5	DELIVERY DATE 03/21/16	DELIVERY MILES 30	PRODUCTION DATE [REDACTED]
	VEHICLE I.D. NO. 1GTV2UEC3FZ	SELLING DEALERSHIP [REDACTED]	R.O. DATE 03/13/17	
PHONE [REDACTED]	COMMENTS			MO: 2743

VIN 1GTV2UEC3FZ [REDACTED] REPAIRING BAC 172 [REDACTED]
 ODOMETER INDICATOR M JOB CARD OPEN DATE 03/13/2017
 ODOMETER 2743 SERVICE ADVISOR GMIN 985894283
 NON-GM VEHICLE N FOREIGN TOURIST
 REFERENCE NUMBER [REDACTED]

JOB	PAY TYPE	TRANS TYPE	CATEGORY	ERA CLAIM#	OEM SAP TRAN.#	VER
1	W	ZREG		[REDACTED]		

JOB COMPLETION DATE: 03/28/2017
 TECHNICIAN GMIN: 743713683

LABOR OPERATION	BASE HOURS	OTHER
5430840	.5	.5

OTHER LABOR OPS (Y/N) N

COMPLAINT CODE: 0621
 COMPLAINT DESCRIPTION: OWNER REPORTS SERVICE BRAKE ASSSIT MESSAGE IND TO BE ON SCANNED CODES ON 3/9/17 C025E 06 CURRENT.CHECK & ADVISE . AT WRITE UP, UP,NO WARNING IND ON AT THIS TIME

CAUSE CODE: 7079
 CAUSE DESCRIPTION: SCANNED SYSTEM CODE C025E-06 BRAKE BOOSTER VACUUM SENSOR CIRCUIT OPEN OR SHORT SIGNAL OR REF CIRCUIT RAN THROUGH FLOW CHART TESTED STED WIRES FROM EBCM TO VACUUM SOLINOD PERFORMED VOLTAGE TEST ON TERNAL 32 L 32 AND 34 OF THE EBCM K17 CONECTOR AND TESTED THE DRAG OF THE TERMANALS ALS IN K17 AND B19B FOUND THE TENSION ON 32 TO BE ON THE WEEKER SIDE OR AL R ALL THE OTHERS BUT STILL HAD TENSION.AT THIS POINT CALLED TECH LINE SPOK SPOKE WITH CURT CASE # [REDACTED] HE WANTS TO REPLACE TERMANAL 32 AN 34

CORRECTION DESCRIPTION: REMOVED AND REPLACED THE 2 TERMANALS #32 AN #34 WIT H NEW TEST DROVE VEHICLE WITH NO PROBLEM

CAUSAL PART: 19119381

PART NUMBER	QTY	UNIT COST	REPLACEMENT SERIAL#	TRADE	NON-GM
19119381	2	5.60			

SERVICE MANAGEMENT AUTHORIZATION CODE: E
 REASON FOR AUTHORIZATION: OLH FOR TESTING VOLTAGE DROP TEST AND TERMINAL TEST ING

WAIVE DEDUCTIBLE (Y/N) N

	TOTAL W/O TAX	TAX	TOTAL
PARTS HANDLING	4.48		
PARTS	11.20	0.00	15.68
LABOR	125.75	0.00	125.75
NET ITEMS	0.00	0.00	0.00
PARTICIPATION AMOUNT		(0.00)
TRANSACTION	141.43	0.00	141.43



GREENWOOD CHEVROLET BUICK GMC

270 SAN FELIPE ROAD • HOLLISTER • CA 95023

www.greenwoodmotors.com

831.637.5328



NOTICE TO CONSUMER: PLEASE READ IMPORTANT WARRANTY INFORMATION ON BACK.

BAR # ARD214044

14143 3/30

EPA # CAR 000240804

CUSTOMER NO.	ADVISOR ROGER DUTRA	TAG NO. 344	INVOICE DATE 03/28/17	INVOICE NO.
	LICENSE NO.	MILEAGE 2,743	COLOR BRONZE/	STOCK NO. 18416
	YEAR / MAKE / MODEL 15/GMC/SIERRA 1500/EXT CAB 4WD 143.5	VEHICLE I.D. NO. 1GT V 2UEC3FZ	DELIVERY DATE 03/21/16	DELIVERY MILES 30
	F.T.E. NO.	P.O. NO.	SELLING DEALER NO.	PRODUCTION DATE
	PHONE	COMMENTS	R.O. DATE 03/13/17	

MO: 2743

JOB# 1 CHARGES

LABOR
1 09CVZ ELECTRICAL TECH(S): 167 WARRANTY

OWNER REPORTS SERVICE BRAKE ASSIT MESSAGE IND TO BE ON
SCANNED CODES ON 3/9/17 C025E 06 CURRENT.CHECK & ADVISE

AT WRITE UP,NO WARNING IND ON AT THIS TIME
SCANNED SYSTEM CODE C025E.06 BRAKE BOOSTER VACUUM SENSOR
CIRCUIT OPEN OR SHORT SIGNAL OR REF CIRCUIT RAN THROUGH
FLOW CHART TESTED WIRES FROM EBCM TO VACUUM SOLINOD
PERFORMED VOLTAGE TEST ON TERNAL 32 AND 34 OF THE EBCM K17
CONECTOR AND TESTED THE DRAG OF THE TERMANALS IN K17 AND
B19B FOUND THE TENSION ON 32 TO BE ON THE WEEKER SIDE OR
ALL THE OTHERS BUT STILL HAD TENSION.AT THIS POINT CALLED
TECH LINE SPOKE WITH CURT CASE # HE WANTS TO
REPLACE TERNAL 32 AN 34
REMOVED AND REPLACED THE 2 TERMANALS #32 AN #34 WITH NEW
TEST DROVE VEHICLE WITH NO PROBLEM

PARTS	QTY	FP-NUMBER	DESCRIPTION	UNIT PRICE	WARRANTY
	2	19119381	WIRE 8.965		0.00
				TOTAL - PARTS	0.00

JOB# 1 TOTALS

JOB# 1 JOURNAL PREFIX CVCS JOB# 1 TOTAL 0.00

TOTALS

*****			TOTAL LABOR....	0.00
* [] CASH [] CHECK CHECK # [] *			TOTAL PARTS....	0.00
* [] VISA [] MASTERCARD [] DISCOVER *			TOTAL SUBLET...	0.00
* [] AMER EXPRESS [] OTHER [] CHARGE *			TOTAL G.O.G....	0.00
*****			TOTAL MISC CHG.	0.00
			TOTAL MISC DISC	0.00
			TOTAL TAX.....	0.00
			TOTAL INVOICE \$	0.00

THANK YOU FOR YOUR BUSINESS !!
YOUR COMPLETE SATISFACTION IS OUR #1 GOAL.

K17 Electronic Brake Control Module

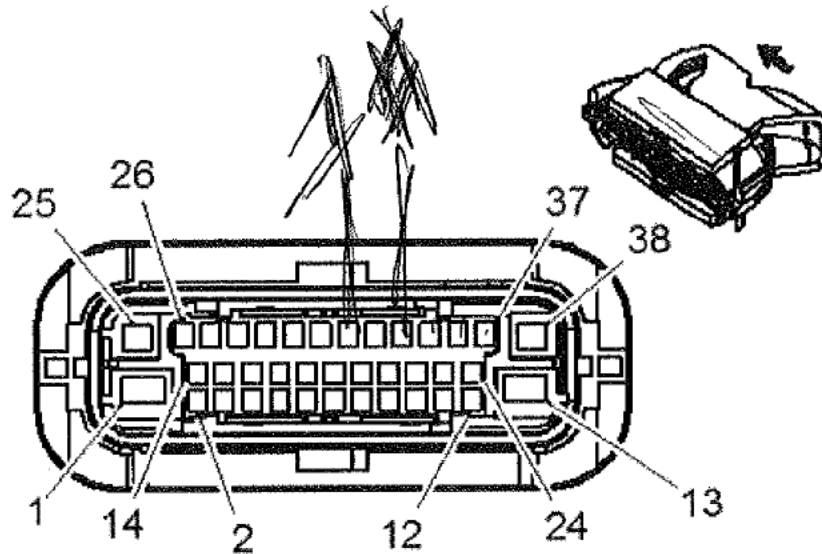

32
34

Connector Part Information

- Harness Type: Chassis
- OEM Connector: 33102987
- Service Connector: 19329396
- Description: 38-Way F 1.5 CTS, 2.8 MCP, 4.8 MCP Series, Sealed (BK)

Terminal Part Information

Terminal Type ID	Terminated Lead	Diagnostic Test Probe	Terminal Removal Tool	Service Terminal	Tray Name	Core Crimp	Insulation Crimp
I	13575368	J-35616-35 (VT)	J-38125-557	Not Required	Not Required	Not Required	Not Required
II	19119381	J-35616-14 (GN)	J-38125-215A	Not Required	Not Required	Not Required	Not Required
III	19119560	J-35616-40 (BU)	J-38125-556	Not Required	Not Required	Not Required	Not Required
IV	19329757	J-35616-14 (GN)	J-38125-215A	Not Required	Not Required	Not Required	Not Required

✓	GMC 2 Year Scheduled Maintenance	03/21/2016	49 MI	03/21/2018	24,049 MI
✓	Emission Select Component Ltd Wly	03/21/2016	49 MI	03/21/2024	80,049 MI
✓	Emission Limited Warranty	03/21/2016	49 MI	03/21/2019	50,049 MI
✓	Bumper to Bumper Limited Warranty	03/21/2016	49 MI	03/21/2019	36,049 MI

Service Contract

Vehicle has no current record of service contracts.

Transaction History

[View Details](#)

Job Card Date	Job Card Number	Transaction Type	Transaction Adjustment	Labour Operation	Odometer Reading
12/22/2016		ZREG---Regular Vehicle Transaction		2441640 - Power Brake Booster Vacuum Pipe Replacement	2,276 MI
10/03/2016		ZFAT---Field Action Recall		9102276 - 18007 - N16-204817 - Inflatable Restraint Sensing and Diagnostic Module Reprogramming w	1,744 MI
07/10/2015		ZPDI---Pre-Delivery Inspection		0590032 - PDI - Dealer Installed - Factory Invoiced Options	2 MI
06/18/2015		ZPDI---Pre-Delivery Inspection		0590072 - Pre-Delivery Inspection - Base Time	1 MI

Global Warranty Management: Site Map

[Privacy Policy](#) | [Terms of Use](#)

© 2005 General Motors. All rights reserved.



Roger Dutra
March 13, 2017

[Update My Profile](#)
[Logout](#)

Global Warranty Management: Main > Interface With Customer > View Vehicle Summary

INTERFACE WITH
CUSTOMER

View Vehicle Summary

This screen allows IVH users to view the Summary of Vehicle Information, Field Actions, Service Information, Applicable Warranties, Transaction History, Service Contract(s) if applicable, Warranty Block, Branded Title information and OnStar and XM Radio information (if applicable).

For this vehicle:

- [View Vehicle Summary](#)
- [Service Contract](#)
- [Branded Title](#)
- [Warranty Block](#)
- [View Vehicle Build](#)
- [View Vehicle Component Summary](#)
- [View Vehicle Transaction History Detail](#)
- [View Vehicle Delivery Information](#)
- [Investigate Major Assembly History](#)

Vehicle Information

VIN: 1GTV2UEC3FZ [REDACTED] Model: TK15753-2015 SIERRA 1500 4WD DOUBLE CAB
Service Contract: No Branded Title: No Warranty Block: No PDI Status: Yes
Order Type: 70 - RETAIL - STOCK
Field Actions: [0 Open](#) [REQUEST ANOTHER VIN](#)

Required Field Actions

Open Field Action Details are highlighted

Type	Number	Original Nbr	Description	Release Date	Status
Product Safety Recall	[REDACTED]	[REDACTED]	Frontal Airbag And Pretensioner Non Deploy	09/08/2016	Closed

Branded Title

*The VIN information contained herein and information derived therefrom is the proprietary property of The Polk Company and is to be used only for the purpose of warranty verification and shall not be used for any other purpose whatsoever.

Vehicle has no current record of branded titles.

Warranty Block

Vehicle has no current record of warranty block.

Service Information

Vehicle has no current record of outstanding service information.

OnStar and XM Satellite Radio Information

Refer to Help page for details. For OnStar contact 888.ON.STAR1 (888.667.8271) and for XM Radio contact 877.GET.XMST (877.438.9677 Canada) and in the USA: 800-556-3600.

OnStar Equipped: Y OnStar Status: Active
XM Equipped: Y XM Radio ID: 6HLYD3RV XM Status: Active
OnStar Vehicle Diagnostics: Y DMN Enabled: Y

Applicable Warranties

Valid warranties are highlighted

Valid	Description	Start Date	Effective Odometer	End Date	End Odometer
✓	Powertrain Limited Warranty	03/21/2016	49 MI	03/21/2021	100,049 MI
✓	Emission Select State Component Ltd Wty	03/21/2016	49 MI	03/21/2023	70,049 MI
✓	Corrosion Limited Warranty	03/21/2016	49 MI	03/21/2022	100,049 MI

Hydraulic Brake Schematics

Hydraulic Brakes

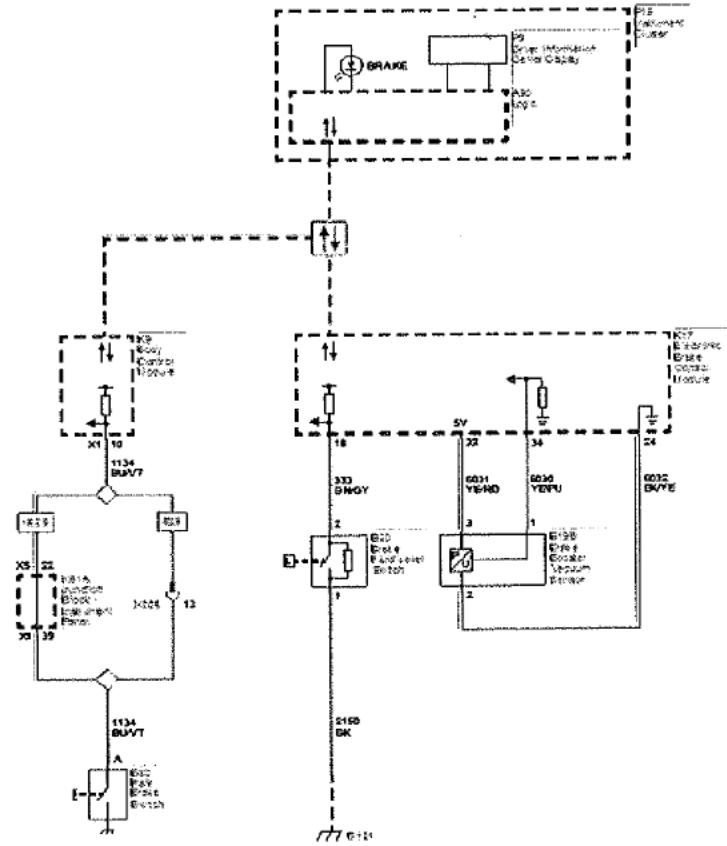

Instrument Cluster	No DTCs Stored	0	1
Radio Controls	No DTCs Stored	0	1
HVAC Controls	No DTCs Stored	0	1
Radio	No DTCs Stored	0	1
Amplifier	No Communication	0	1
Media Disc Player	No Communication	0	1
Human Machine Interface Control Module	DTCs Stored	1	6,14
Telematics Communication Interface Control Module	No DTCs Stored	0	6,14
HVAC Control Module	No DTCs Stored	0	1
Seat Memory Control Module - Driver	No Communication	0	1
Parking Assist Control Module	No Communication	0	1

Control Module	DTC Display	Symptom Byte	DTC Description	Symptom Description	Status	
Human Machine Interface Control Module	B124B	04	Universal Serial Bus (USB) Circuit 1	Open	Current	
					DTC Current Status	Current
					DTC History Status	History
Electronic Brake Control Module	C025E	06	Brake Booster Vacuum Sensor Circuit	Low Voltage/Open	Current	
					This Ignition Cycle	Passed and Failed
					DTC Current Status	Current
					DTC History Status	History
					MIL Status	Requested

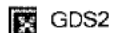

Global Diagnostic System 2

Vehicle DTC Information

Overview

Vehicle Identification Number (VIN) 1GTV2UEC3FZ [REDACTED]
Report Creation Date 2017-03-09 13:47:40 PST

Vehicle Configuration Property

Make GMC
Model Sierra
Model Year 2015

System Information Property

VCI Serial Number MDI [REDACTED]
Vehicle Session Creation Date 2017-03-09 13:46:38
Test Start Time 2017-03-09 13:47:14 PST

Control Module Name	Control Module Status	DTC Count	DLC Pin
Engine Control Module	No DTCs Stored	0	6,14
Chassis Control Module	No DTCs Stored	0	6,14
Transmission Control Module	No DTCs Stored	0	6,14
Transfer Case Control Module	No DTCs Stored	0	6,14
Electronic Brake Control Module	DTCs Stored	1	6,14
Distance Sensing Cruise Control Module	No Communication	0	6,14
Parking Brake Control Module	No Communication	0	6,14
Power Steering Control Module	No DTCs Stored	0	6,14
Steering Wheel Angle Sensor Module	No DTCs Stored	0	12,13
Suspension Control Module	No Communication	0	6,14
Body Control Module	No DTCs Stored	0	6,14
Inflatable Restraint Sensing and Diagnostic Module	No DTCs Stored	0	1
Passenger Presence Module	No DTCs Stored	0	1

↓ **If less than 2 Ω**

10. Test or replace the B19B Brake Booster Vacuum Sensor.

Repair Instructions

Perform the Diagnostic Repair Verification after completing the repair.

- Power Brake Booster Vacuum Sensor Replacement
- Control Module References for electronic brake control module replacement, programming and setup

1. Ignition OFF and all vehicle systems OFF, disconnect the harness connector at the B19B Brake Booster Vacuum Sensor. It may take up to 2 min for all vehicle systems to power down.
2. Test for less than 10 Ω between the low reference circuit terminal 2 and ground.
⇒ **If 10 Ω or greater**
 - 2.1. Disconnect the harness connector at the K17 Electronic Brake Control Module.
 - 2.2. Test for less than 2 Ω in the low reference circuit end to end.
⇒ If 2 Ω or greater, repair the open/high resistance in the circuit.
⇒ If less than 2 Ω , replace the K17 Electronic Brake Control Module.
- ↓ **If less than 10 Ω**
3. Ignition ON.
4. Test for 4.8–5.2 V between the 5 V reference circuit terminal 3 and ground.
⇒ **If less than 4.8 V**
 - 4.1. Ignition OFF, disconnect the harness connector at the K17 Electronic Brake Control Module.
 - 4.2. Test for infinite resistance between the 5 V reference circuit and ground.
⇒ If less than infinite resistance, repair the short to ground on the circuit.
↓ If infinite resistance
 - 4.3. Test for less than 2 Ω in the 5 V reference circuit end to end.
⇒ If 2 Ω or greater, repair the open/high resistance in the circuit.
⇒ If less than 2 Ω , replace the K17 Electronic Brake Control Module.
- ⇒ **If greater than 5.2 V**
 - 4.1. Ignition OFF, disconnect the harness connector at the K17 Electronic Brake Control Module, ignition ON.
 - 4.2. Test for less than 1 V between the 5 V reference circuit and ground.
⇒ If 1 V or greater, repair the short to voltage on the circuit.
⇒ If less than 1 V, replace the K17 Electronic Brake Control Module.
- ↓ **If between 4.8–5.2 V**
5. Ignition OFF, disconnect the harness connector at the K17 Electronic Brake Control Module, Ignition ON.
6. Test for less than 1 V between the B19B Brake Booster Vacuum Sensor signal circuit terminal 1 and ground.
⇒ **If greater than 1 V**
Repair the short to voltage on the circuit.
- ↓ **If less than 1 V**
7. Ignition OFF.
8. Test for infinite resistance between the B19B Brake Booster Vacuum Sensor signal circuit terminal 1 and ground.
⇒ **If less than infinite resistance**
Repair the short to ground on the circuit.
- ↓ **If infinite resistance**
9. Test for less than 2 Ω between the B19B Brake Booster Vacuum Sensor signal circuit terminal 1 and the K17 Electronic Brake Control Module signal circuit terminal 34.
⇒ **If 2 Ω or greater**
Repair the open/high resistance in the circuit.

C025E 06

- An open/high is detected on the signal circuit.
- A short to ground is detected on the signal circuit.
- An open/high is detected on the 5V reference circuit.

C025E 1F

The vacuum sensor signal is erratic.

C025E 5A

The vacuum sensor signal is not plausible.

Action Taken When the DTC Sets

Service Brake Assist message is displayed on the driver information center

Conditions for Clearing the DTC

The DTC clears when the diagnostic runs and passes

Reference Information

Schematic Reference

Hydraulic Brake Schematics

Connector End View Reference

Component Connector End Views

Description and Operation

Brake Assist System Description and Operation

Electrical Information Reference

- Circuit Testing
- Connector Repairs
- Testing for Intermittent Conditions and Poor Connections
- Wiring Repairs

DTC Type Reference

Powertrain Diagnostic Trouble Code (DTC) Type Definitions

Scan Tool Reference

Control Module References for scan tool information

Circuit/System Verification

1. Verify that the brake booster vacuum system has no damage, leakage or incorrect installation.
⇒ **If damage, leakage or incorrect installation is found**
Refer to Brake Assist System Diagnosis
↓ **If no damage, leakage or incorrect installation is found**
2. Refer to Circuit/System Testing.

Circuit/System Testing

DTC C025E

Diagnostic Instructions

- Perform the Diagnostic System Check - Vehicle prior to using this diagnostic procedure.
- Review Strategy Based Diagnosis for an overview of the diagnostic approach.
- Diagnostic Procedure Instructions provides an overview of each diagnostic category.

DTC Descriptor

DTC C025E Brake Booster Vacuum Sensor Circuit

For symptom byte information refer to Symptom Byte List.

Diagnostic Fault Information

Circuit	Short to Ground	Open/High Resistance	Short to Voltage	Signal Performance
5V Reference	C025E 00	C025E 06	C025E 00	—
Sensor Signal	C025E 06	C025E 06	C025E 01	C025E 1F, C025E 5A
Low Reference	—	C025E 01	—	—

Circuit/System Description

The brake booster vacuum sensor monitors the pressure in the brake booster. The electronic brake control module supplies a 5V reference and a low reference circuit to the brake booster vacuum sensor. The vacuum sensor supplies a voltage signal in relation to the pressure in the brake booster to the electronic brake control module.

Conditions for Running the DTC

C025E 00, C025E 01, C025E 06, C025E 1F

Ignition ON

C025E 5A

- Ignition ON.
- Brakes are not applied.

Conditions for Setting the DTC

C025E 00

- A short to ground is detected on the 5V reference circuit.
- A short to voltage is detected on the 5V reference circuit.

C025E 01

- A short to voltage is detected on the signal circuit.
- An open/high resistance is detected on the low reference circuit.

04-09-'18 23:42 FROM- Greenwood Chevrolet 881-313-1537 T-216 P0036/0050 F-804

J2534 Pass Thru: Final Instructions

Programming Complete.

Electronic Brake Control Module - Setup and Configuration (K17)
2017-06-20 11:21:07 -07:00

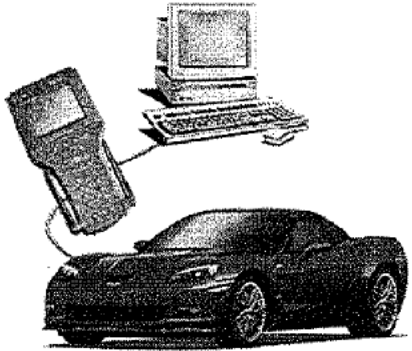

Warranty Claim Code [REDACTED]

Record this code on the warranty repair order (applicable).

Post Programming Instructions:

Follow the Controller Specific Instructions below.

If there are no Controller Specific Instructions, turn ignition off for 30 seconds to reset the controller.

Controller Specific Instructions:

[REDACTED] Clearing DTCs will erase stored history data from all controllers on the Data Link Connector currently in use. Move your interface to any additional Auxiliary Data Connectors on the vehicle to clear DTCs from other controllers. When finished, return the interface to the Data Link Connector.

VIN1GTV2UEC3FZ [REDACTED]

Print

Clear DTCs

Proceed with same VIN

New

Cancel



GREENWOOD CHEVROLET BUICK GMC

270 SAN FELIPE ROAD • HOLLISTER • CA 95023

www.greenwoodmotors.com

831.637.5328



NOTICE TO CONSUMER: PLEASE READ IMPORTANT WARRANTY INFORMATION ON BACK.

BAR # ARD214044

EPA # CAR 000240804

CUSTOMER NO.	ADVISOR ROGER DUTRA	TAG NO. 344	INVOICE DATE 03/30/17	INVOICE NO.
	LICENSE NO.	MILEAGE 2,743	COLOR BRONZE/	STOCK NO.
	YEAR / MAKE / MODEL 15/GMC/SIERRA 1500/EXT CAB 4WD 143.5		DELIVERY DATE 03/21/16	DELIVERY MILES 30
	VEHICLE I.D. NO. 1 G T V 2 U E C 3 F Z		SELLING DEALER NO.	PRODUCTION DATE
	F.T.E. NO.	P. O. NO.	R. O. DATE 03/13/17	
COMMENTS				

MO: 2743

JOB# 1 CHARGES

LABOR

J# 1 09CVZ ELECTRICAL HOURS: 1.00 TECH(S): 167 125.75

TECH#	DATE	START	FINISH	ACT	TIME	DESCRIPTION
167	03/13/17	16.00	16.60	0.60	0.00	HOLD OTHER
167	03/14/17	10.80	11.60	0.80	0.00	HOLD OTHER
167	03/28/17	15.40	16.30	0.90	0.00	FINISHED
167	03/30/17	0.00	0.00	0.00	1.00	VERRIDE IN INVOICING
TOTAL TECH TIME				2.30	1.00	

OWNER REPORTS SERVICE BRAKE ASSIT MESSAGE IND TO BE ON SCANNED CODES ON 3/9/17 C025E 06 CURRENT.CHECK & ADVISE

AT WRITE UP, NO WARNING IND ON AT THIS TIME
 SCANNED SYSTEM CODE C025E-06 BRAKE BOOSTER VACUUM SENSOR
 CIRCUIT OPEN OR SHORT SIGNAL OR REF CIRCUIT RAN THROUGH
 FLOW CHART TESTED WIRES FROM EBCM TO VACUUM SOLINOD
 PERFORMED VOLTAGE TEST ON TERNAL 32 AND 34 OF THE EBCM K17
 CONECTOR AND TESTED THE DRAG OF THE TERMANALS IN K17 AND
 B19B FOUND THE TENSION ON 32 TO BE ON THE WEEKER SIDE OR
 ALL THE OTHERS BUT STILL HAD TENSION AT THIS POINT CALLED
 TECH LINE SPOKE WITH CURT CASE # [REDACTED] HE WANTS TO
 REPLACE TERMANAL 32 AN 34
 REMOVED AND REPLACED THE 2 TERMANALS #32 AN #34 WITH NEW
 TEST DROVE VEHICLE WITH NO PROBLEM

PARTS

QTY	FP-NUMBER	DESCRIPTION	U/COST	E/COST	U/PRICE
2	19119381	WIRE 8.965	5.60	11.20	7.84
COST TOTAL				11.20	
TOTAL - PARTS					15.68

JOB# 1 TOTALS

LABOR	125.75
PARTS	15.68
JOB# 1 JOURNAL PREFIX CVWS	
JOB# 1 TOTAL	141.43
R/O TAX	0.00
R/O TOTALS	141.43

MAR 30 PAID

WARRANTY CLAIM DETAIL TOTALS

CLAIM#	TOTAL
[REDACTED]	141.43
CLAIM TOTALS	141.43

APPROVED BY SIGNATURE

DCS AUDIT SLIP

JOB CARD



GREENWOOD CHEVROLET BUICK GMC

270 SAN FELIPE ROAD • HOLLISTER • CA 95023

www.greenwoodmotors.com

831.637.5328

NOTICE TO CONSUMER: PLEASE READ IMPORTANT WARRANTY INFORMATION ON BACK.

BAR # ARD214044

EPA # CAR 000240804

CUSTOMER NO.	ADVISOR ROGER DUTRA	TAG NO.	INVOICE DATE 06/28/17	INVOICE NO.
	LICENSE NO.	MILEAGE 3,591	COLOR BRONZE/	STOCK NO.
	YEAR / MAKE / MODEL 15/GMC/SIERRA 1500/EXT CAB 4WD 143.5		DELIVERY DATE 03/21/16	DELIVERY MILES 30
	VEHICLE I.D. NO. 1GTV2UEC3FZ		SELLING DEALER NO.	PRODUCTION DATE
	F.T.E. NO.		R.O. DATE 06/19/17	
TELEPHONE	COMMENTS			

MO: 3597

DCS AUDIT SLIP

JOB CARD

VIN 1GTV2UEC3FZ
 ODOMETER INDICATOR M
 ODOMETER 3591
 NON-GM VEHICLE N
 REFERENCE NUMBER
 REPAIRING BAC 172
 JOB CARD OPEN DATE 06/19/2017
 SERVICE ADVISOR GHIN 985894283
 FOREIGN TOURIST

JOB	PAY TYPE	TRANS TYPE	CATEGORY	ERA CLAIM#	OEM SAP TRAN.#	VER
1	W	ZREG				

JOB COMPLETION DATE: 06/20/2017
 TECHNICIAN GMIN: 692370914

LABOR OPERATION	BASE HOURS	DIAGNOSIS	OTHER
2410370	.6	.3	.4

OTHER LABOR OPS (Y/N) N

COMPLAINT CODE: 0621

COMPLAINT DESCRIPTION: OWNER REPORTS SERVICE BRAKE ASSIST MESSAGE TO BE ON. SCANNED CODE ON 6/16/17 C025E-06 WAS PRESENT. CHECK & ADVISE

CAUSE CODE: 6573

CAUSE DESCRIPTION: VERIFIED CONCERN. CHK CODES AND FOUND C025E-BRAKE BOOSTER VAC UUM SENSOR CIRC. TESTED SYSTEM CIRC AND WAS GOOD, TRACED FAULT TO IN O INTERNAL FAILURE WITH EBCM.

CORRECTION DESCRIPTION: REPLACED EBCM, PROGRAMMED AND PERFORMED SET UP/CONFIGURATION PROCEDURES. CLEARED CODES AND TEST DROVE. TESTED GOOD AND CODES DID NOT RESET. CLAIM CODES 28DCD FOR PROGRAMMING, AND S2 A70 FOR SET UP/CONFIG.

CAUSAL PART: 23154722

PART NUMBER	QTY	UNIT COST	REPLACEMENT SERIAL#	TRADE	NON-GM
23154722	1	114.20			

SERVICE MANAGEMENT AUTHORIZATION CODE: E
 REASON FOR AUTHORIZATION: OLH FOR PROGRAMMING 28DCD

WAIVE DEDUCTIBLE (Y/N) N

	TOTAL W/O TAX	TAX	TOTAL
PARTS HANDLING	45.68		
PARTS	114.20	0.00	159.88
LABOR	163.48	0.00	163.48
NET ITEMS	0.00	0.00	0.00
PARTICIPATION AMOUNT			(0.00)
TRANSACTION	323.36	0.00	323.36



GREENWOOD CHEVROLET BUICK GMC

270 SAN FELIPE ROAD • HOLLISTER • CA 95023

www.greenwoodmotors.com

831.637.5328



NOTICE TO CONSUMER: PLEASE READ IMPORTANT WARRANTY INFORMATION ON BACK.

BAR # ARD214044

JUN 27 2017 323 3/4

EPA # CAR 000240804

CUSTOMER NO.	ADVISOR ROGER DUTRA	TAG NO. 344	INVOICE DATE 06/20/17	INVOICE NO.
	LICENSE NO.	MILEAGE 3,591	COLOR BRONZE/	STOCK NO.
	YEAR / MAKE / MODEL 15/GMC/SIERRA 1500/EXT CAB 4WD 143.5		DELIVERY DATE 03/21/16	DELIVERY MILES 30
	VEHICLE I.D. NO. 1GTV2UEC3FZ		SELLING DEALER NO.	PRODUCTION DATE
	F.T.E. NO.	R.O. NO.	R.O. DATE 06/19/17	
PHONE	COMMENTS			

MO: 3597

JOB# 1 CHARGES

LABOR
1 09CVZ ELECTRICAL TECH(S):198 WARRANTY

OWNER REPORTS SERVICE BRAKE ASSIST MESSAGE TO BE ON. SCANNED CODE ON 6/16/17 C025E-06 WAS PRESENT. CHECK & ADVISE VERIFIED CONCERN. CHK CODES AND FOUND C025E-BRAKE BOOSTER VACUUM SENSOR CIRC. TESTED SYSTEM CIRC AND WAS GOOD, TRACED FAULT TO INTERNAL FAILURE WITH EBCM. REPLACED EBCM, PROGRAMMED AND PERFORMED SET UP/CONFIGURATION PROCEDURES. CLEARED CODES AND TEST DROVE. TESTED GOOD AND CODES DID NOT RESET. CLAIM CODES 28DCD FOR PROGRAMMING, AND S2 A70 FOR SET UP/CONFIG.

PARTS	QTY	FP-NUMBER	DESCRIPTION	UNIT PRICE	WARRANTY
	1	23154722	MODULE KI 4.720		
				TOTAL - PARTS	0.00

JOB# 1 TOTALS

JOB# 1 JOURNAL PREFIX CVCS JOB# 1 TOTAL 0.00

COMMENTS
DROPPING OFR FOR TUESDAY..3RD TIME BACK

TOTALS

*****		TOTAL LABOR....	0.00
*		TOTAL PARTS....	0.00
* [] CASH [] CHECK CHECK # []		TOTAL SUBLET...	0.00
*		TOTAL G.O.G....	0.00
* [] VISA [] MASTERCARD [] DISCOVER		TOTAL MISC CHG.	0.00
*		TOTAL MISC DISC	0.00
* [] AMER EXPRESS [] OTHER [] CHARGE		TOTAL TAX.....	0.00
*****		TOTAL INVOICE \$	0.00

J2534 Pass Thru: Final Instructions

Programming Complete.

Electronic Brake Control Module - Setup and Configuration (K17)

2017-06-20 11:21:07 -07:00

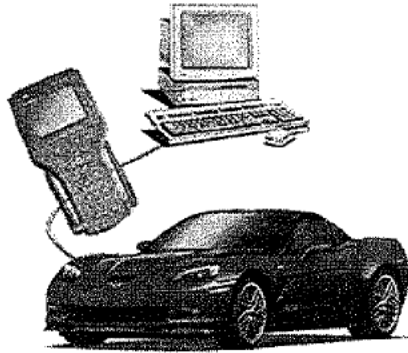

Warranty Claim Code [REDACTED]

Record this code on the warranty repair order (applicable).

Post Programming Instructions:

Follow the Controller Specific Instructions below.

If there are no Controller Specific Instructions, turn ignition off for 30 seconds to reset the controller.

Controller Specific Instructions:

[REDACTED] Clearing DTCs will erase stored history data from all controllers on the Data Link Connector currently in use. Move your interface to any additional Auxiliary Data Connectors on the vehicle to clear DTCs from other controllers. When finished, return the interface to the Data Link Connector.

VIN1GTV2UEC3F2 [REDACTED]



GREENWOOD CHEVROLET BUICK GMC
270 SAN FELIPE ROAD • HOLLISTER • CA 95023
www.greenwoodmotors.com
831.637.5328

NOTICE TO CONSUMER: PLEASE READ IMPORTANT WARRANTY INFORMATION ON BACK.

BAR # ARD214044

EPA # CAR 000240804

Customer information form including fields for Customer No., Advisor (CARLOS MIRANDA), Tag No., Invoice Date (10/06/16), Invoice No., License No., Mileage (1,744), Color (BRONZE/), Stock No., Year/Make/Model (15/GMC/SIERRA 1500/EXT CAB 4WD 143.5), Delivery Date (03/21/16), Delivery Miles (30), Vehicle I.D. No. (1 GTV2UEC3FZ), Selling Dealer No., Production Date, F.T.E. No., R.O. No., R.O. Date (10/03/16), and Comments.

JOB# 1 CHARGES

Table with columns: TECH#, DATE, START, FINISH, ACT, TIME, DESCRIPTION. Includes labor entry for 305 on 10/03/16 (FINISHED) and 10/06/16 (OVERRIDE IN INVOICING).

PERFORM RECALL 16007
WARRANTY CODE #S3070.
PERFORM RECALL.REPROGRAM THE IRSDM.

JOB# 1 TOTALS

Summary table showing LABOR 36.80 and JOB# 1 JOURNAL PREFIX CVWS JOB# 1 TOTAL 36.80.

COMMENTS

R/O TAX 0.00
R/O TOTALS 36.80

OCT 06 PAID

WARRANTY CLAIM DETAIL TOTALS

Table with columns: CLAIM#, TOTAL. Shows a claim total of 36.80.

APPROVED BY SIGNATURE



GREENWOOD CHEVROLET BUICK GMC

270 SAN FELIPE ROAD • HOLLISTER • CA 95023

www.greenwoodmotors.com

831.637.5328



NOTICE TO CONSUMER: PLEASE READ IMPORTANT WARRANTY INFORMATION ON BACK.

BAR # ARD214044

EPA # CAR 000240804

CUSTOMER NO.	ADVISOR CARLOS MIRANDA	TAG NO.	INVOICE DATE 10/06/16	INVOICE NO.
	LICENSE NO. 298	MILEAGE 1,744	COLOR BRONZE/	STOCK NO.
	YEAR / MAKE / MODEL 15/GMC/SIERRA 1500/EXT CAB 4WD 143.5	DELIVERY DATE 03/21/16	DELIVERY MILES 30	PRODUCTION DATE
	VEHICLE ID. NO. 1GTV2UEC3FZ	SELLING DEALER NO.		
	F.T.E. NO.	P.O. NO.	R.O. DATE 10/03/16	
COMMENTS				MO: 1744

DCS AUDIT SLIP-

JOB CARD

VIN 1GTV2UEC3FZ REPAIRING BAC 172
 ODOMETER INDICATOR M JOB CARD OPEN DATE 10/03/2016
 ODOMETER 1744 SERVICE ADVISOR GMIN 570709628
 NON-GM VEHICLE N FOREIGN TOURIST
 REFERENCE NUMBER

JOB	PAY TYPE	TRANS TYPE	CATEGORY	ERA CLAIM#	OEM SAP TRAN.#	VER
1	W	ZFAT				

JOB COMPLETION DATE: 10/03/2016
 TECHNICIAN GMIN: 309454919

LABOR OPERATION BASE HOURS ADD PUB.
 9102276 .2 .1

OTHER LABOR OPS (Y/N) N

CORRECTION DESCRIPTION: PERFORM RECALL.REPROGRAM THE IRSDM. .

WAIVE DEDUCTIBLE (Y/N) N

	TOTAL W/O TAX	TAX	TOTAL
PARTS HANDLING	0.00		
PARTS	0.00	0.00	0.00
LABOR	36.80	0.00	36.80
NET ITEMS	0.00	0.00	0.00
PARTICIPATION AMOUNT			(0.00)
TRANSACTION	36.80	0.00	36.80



GREENWOOD CHEVROLET BUICK GMC

270 SAN FELIPE ROAD • HOLLISTER • CA 95023

www.greenwoodmotors.com

831.637.5328



NOTICE TO CONSUMER: PLEASE READ IMPORTANT WARRANTY INFORMATION ON BACK.

BAR # ARD214044

OCT 06 2016

3680

EPA # CAR 000240804

CUSTOMER NO.	ADVISOR CARLOS MIRANDA	TAG NO. 298	INVOICE DATE 10/03/16	INVOICE NO.
	LICENSE NO.	MILEAGE 1,744	COLOR BRONZE/	STOCK NO.
	YEAR / MAKE / MODEL 15/GMC/SIERRA 1500/EXT CAB 4WD 143.5		DELIVERY DATE 03/21/16	DELIVERY MILES 30
	VEHICLE ID. NO. 1GTV2UEC3FZ		SELLING DEALER NO.	PRODUCTION DATE
	F.T.E. NO.	P.O. NO.	R.O. DATE 10/03/16	
PHONE	COMMENTS			MO: 1744

JOB# 1 CHARGES

LABOR

1 30CVZ RECALL CAMPAIGN TECH(S):305 WARRANTY

PERFORM RECALL 16007
WARRANTY CODE #S3070.
PERFORM RECALL.REPROGRAM THE IRSDM.

JOB# 1 TOTALS

JOB# 1 JOURNAL PREFIX CVCS JOB# 1 TOTAL 0.00

COMMENTS

TOTALS

* [] CASH	* [] CHECK	* CHECK # []	* TOTAL LABOR...	* 0.00
* [] VISA	* [] MASTERCARD	* [] DISCOVER	* TOTAL PARTS...	* 0.00
* [] AMER EXPRESS	* [] OTHER	* [] CHARGE	* TOTAL SUBLET...	* 0.00
			* TOTAL G.O.G....	* 0.00
			* TOTAL MISC CHG.	* 0.00
			* TOTAL MISC DISC	* 0.00
			* TOTAL TAX.....	* 0.00

TOTAL INVOICE \$ 0.00

THANK YOU FOR YOUR BUSINESS !!





GREENWOOD CHEVROLET BUICK GMC

270 SAN FELIPE ROAD • HOLLISTER • CA 95023

www.greenwoodmotors.com

831.637.5328



NOTICE TO CONSUMER: PLEASE READ IMPORTANT WARRANTY INFORMATION ON BACK.

BAR # ARD214044

EPA # CA 0000000000
CELL #

CUSTOMER NO.	ADVISOR CARLOS MIRANDA	TAG NO. 298	INVOICE DATE 10/06/16
	LICENSE NO.	MILEAGE 17,558	COLOR
	YEAR / MAKE / MODEL 15/GMC/SIERRA 1500/CREW CAB 4WD 143.	DELIVERY DATE	DELIVERY MILES
	VEHICLE I.D. NO. 3 G T U 2 V E C 6 F G	SELLING DEALER NO.	PRODUCTION DATE
	F.T.E. NO.	P.O. NO.	R.O. DATE 10/06/16
ONE	COMMENTS		

MO: 17558

JOB# 1 CHARGES

LABOR

TECH#	DATE	START	FINISH	ACT	TIME	DESCRIPTION
126	10/06/16	9.80	10.10	0.30	0.00	FINISHED
126	10/06/16	0.00	0.00	0.00	0.30	OVERRIDE IN INVOICING
TOTAL TECH TIME				0.30	0.30	

PERFORM RECALL 16007
SDM SOFTWARE RECALL
RE-PROGRAMMED THE SDM CODE=S30B9

JOB# 1 TOTALS

LABOR 36.80

JOB# 1 JOURNAL PREFIX CVWS JOB# 1 TOTAL 36.80

COMMENTS

R/O TAX 0.00
R/O TOTALS 36.80

OCT 06 PAID

WARRANTY CLAIM DETAIL TOTALS

CLAIM#	TOTAL
	36.80
CLAIM TOTALS	36.80

APPROVED BY SIGNATURE



GREENWOOD CHEVROLET BUICK GMC

270 SAN FELIPE ROAD • HOLLISTER • CA 95023

www.greenwoodmotors.com

831.637.5328

NOTICE TO CONSUMER: PLEASE READ IMPORTANT WARRANTY INFORMATION ON BACK.

BAR # ARD214044

EPA # CAR 000240804

CUSTOMER NO.	ADVISOR CARLOS MIRANDA	TAG NO. 298	INVOICE DATE 10/06/16	INVOICE NO.
	LICENSE NO.	MILEAGE 17,558	COLOR /	STOCK NO.
	YEAR / MAKE / MODEL 15/GMC/SIERRA 1500/CREW CAB 4WD 143.		DELIVERY DATE	DELIVERY MILES
	VEHICLE I.D. NO. 3GTU2VEC6FG		SELLING DEALER NO.	PRODUCTION DATE
	F.T.E. NO.	P.O. NO.	R.O. DATE 10/06/16	
COMMENTS				MO: 17558

DCS AUDIT SLIP

JOB CARD

VIN 3GTU2VEC6FG REPAIRING BAC 172
 ODOMETER INDICATOR M JOB CARD OPEN DATE 10/06/2016
 ODOMETER 17558 SERVICE ADVISOR GMIN 570709628
 NON-GM VEHICLE N FOREIGN TOURIST
 REFERENCE NUMBER

JOB	PAY TYPE	TRANS TYPE	CATEGORY	ERA CLAIM#	OEM SAP TRAN.#	VER
1	W	ZFAT				

JOB COMPLETION DATE: 10/06/2016
 TECHNICIAN GMIN: 113732608

LABOR OPERATION	BASE HOURS	ADD PUB.
9102276	.2	.1

OTHER LABOR OPS (Y/N) N

CORRECTION DESCRIPTION: RE-PROGRAMMED THE SDM CODE=S30B9

WAIVE DEDUCTIBLE (Y/N) N

	TOTAL W/O TAX	TAX	TOTAL
PARTS HANDLING	0.00		
PARTS	0.00	0.00	0.00
LABOR	36.80	0.00	36.80
NET ITEMS	0.00	0.00	0.00
PARTICIPATION AMOUNT			(0.00)
TRANSACTION	36.80	0.00	36.80



GREENWOOD CHEVROLET BUICK GMC

270 SAN FELIPE ROAD • HOLLISTER • CA 95023

www.greenwoodmotors.com

831.637.5328

NOTICE TO CONSUMER: PLEASE READ IMPORTANT WARRANTY INFORMATION ON BACK.

BAR # ARD214044

EPA # CAP 000240804

CUSTOMER NO.	ADVISOR CARLOS MIRANDA	TAG NO. 298	INVOICE DATE 10/06/16
	LICENSE NO.	MILEAGE 17,558	COLOR
	YEAR / MAKE / MODEL 15/GMC/SIERRA 1500/CREW CAB 4WD 143.		STOCK NO.
	VEHICLE I.D. NO. 3GTU2VEC6FG		DELIVERY DATE
	F.T.E. NO.	P.O. NO.	DELIVERY MILES
			SELLING DEALER NO.
			PRODUCTION DATE
			R.O. DATE 10/06/16
COMMENTS			MO: 17558

JOB# 1 CHARGES-----

LABOR-----

J# 1 30CVZ RECALL CAMPAIGN TECH(S):126 WARRANTY

PERFORM RECALL 16007
SDM SOFTWARE RECALL
RE-PROGRAMMED THE SDM CODE=S30B9

JOB# 1 TOTALS-----

JOB# 1 JOURNAL PREFIX CVCS JOB# 1 TOTAL 0.00

COMMENTS-----

TOTALS-----

*****	TOTAL LABOR....	0.00
* [] CASH [] CHECK CHECK # []	TOTAL PARTS....	0.00
* [] VISA [] MASTERCARD [] DISCOVER	TOTAL SUBLET...	0.00
* [] AMER EXPRESS [] OTHER [] CHARGE	TOTAL G.O.G....	0.00
*****	TOTAL MISC CHG.	0.00
	TOTAL MISC DISC	0.00
	TOTAL TAX.....	0.00
	TOTAL INVOICE \$	0.00

OCT 08 2016

THANK YOU FOR YOUR BUSINESS !!
YOUR COMPLETE SATISFACTION IS OUR #1 GOAL

From: cmichener <cmichener@4rally.com>

To: [REDACTED]

Subject: OPEN RECALL

Date: Mon, Sep 26, 2016 10:42 am

HI THERE. HERE IS THE INFORMATION ON THE OPEN RECALL FOR YOUR 2015 GMC SIERRA:

Open Field Frontal Airbag And Pretensioner Non Deploy Recall #16007
Action

Cortney Michener

Service Advisor

Rally Auto Group

661.947.6000 Main

661.274.7011 Direct

cmichener@4rally.com



GREENWOOD CHEVROLET BUICK GMC

270 SAN FELIPE ROAD • HOLLISTER • CA 95023

www.greenwoodmotors.com

831.637.5328



APR 07 2018

NOTICE TO CONSUMER PLEASE READ IMPORTANT WARRANTY INFORMATION ON BACK.

BAR # ARD214044

EPA # CAR 000240804

CUSTOMER NO.	ADVISOR CARLOS MIRANDA	TAG NO. 298	INVOICE DATE 04/06/16	INVOICE NO.
	LICENSE NO.	MILEAGE 202	COLOR BRONZE/	STOCK NO.
	YEAR / MAKE / MODEL 15/GMC/SIERRA 1500/EXT CAB 4WD 143.5		DELIVERY DATE 03/21/16	DELIVERY MILES 30
	VEHICLE I.D. NO. 1GT V 2UEC3E7		SELLING DEALER NO.	PRODUCTION DATE
	F.T.E. NO.		R.O. DATE 04/04/16	
	COMMENTS			

MO: 230

JOB# 1 CHARGES

LABOR
 # 1 50CVZ SUBLET TECH(S):379 INTERNAL
 SUBLET TO LINEX FOR BED SPRAY LINER
 SUBLET TO LINEX FOR BED SPRAY LINER

SUBLET PO# 68477 VEND INV# 04/06/16 INV DATE-DESCRIPTION SPRAY BED LINER
 TOTAL - SUBLET INTERNAL 0.00

JOB# 1 TOTALS
 JOB# 1 JOURNAL PREFIX CVCS JOB# 1 TOTAL 0.00

JOB# 2 CHARGES
 LABOR
 # 2 51CVZ PERMA PLATE TECH(S):379 INTERNAL
 PERF PERMA PLATE

JOB# 2 TOTALS
 JOB# 2 JOURNAL PREFIX CVCS JOB# 2 TOTAL 0.00

TOTALS

 * [] CASH [] CHECK CHECK # [] *
 * [] VISA [] MASTERCARD [] DISCOVER *
 * [] AMER EXPRESS [] OTHER [] CHARGE *
 * *
 TOTAL LABOR.... 0.00
 TOTAL PARTS.... 0.00
 TOTAL SUBLET... 0.00
 TOTAL G.O.G.... 0.00
 TOTAL MISC CHG. 0.00
 TOTAL MISC DISC 0.00
 TOTAL TAX..... 0.00

 TOTAL INVOICE \$ 0.00

THANK YOU FOR YOUR BUSINESS !!





GREENWOOD CHEVROLET BUICK GMC

270 SAN FELIPE ROAD • HOLLISTER • CA 95023

www.greenwoodmotors.com

831.637.5328



NOTICE TO CONSUMER PLEASE READ IMPORTANT WARRANTY INFORMATION ON BACK.

BAR # ARD214044

EPA # CAR 000240804

CUSTOMER NO.	ADVISOR CARLOS MIRANDA	TAG NO.	INVOICE DATE 04/06/16	INVOICE NO.
	LICENSE NO.	MILEAGE 298	COLOR BRONZE/	STOCK NO.
	YEAR / MAKE / MODEL 15/GMC/SIERRA 1500/EXT CAB 4WD 143.5	202	DELIVERY DATE 03/21/16	DELIVERY MILES 30
	VEHICLE I.D. NO. 1GTV2UEC3E7		SELLING DEALER NO.	PRODUCTION DATE
	F.T.E. NO.		R. O. DATE 04/04/16	
COMMENTS				

MO: 230

JOB# 1 CHARGES

LABOR

JOB#	TECH#	DATE	START	FINISH	ACT	TIME	TECH(S)	DESCRIPTION	HOURS
1	50CVZ						379		0.00
	379	04/04/16	15.10	15.10	0.00	0.00		FINISHED	
	379	04/04/16	0.00	0.00	0.00	0.00		FINISHED	
			TOTAL TECH TIME		0.00	0.00			

SUBLET TO LINEX FOR BED SPRAY LINER
SUBLET TO LINEX FOR BED SPRAY LINER

SUBLET

PO#	VEND	INV#	INV. DATE	DESCRIPTION	AMOUNT
68477			04/06/16	SPRAY BED LINER	550.00
				TOTAL - SUBLET	550.00

JOB# 1 TOTALS

SUBLET	550.00
JOB# 1 JOURNAL PREFIX CVIS	
JOB# 1 TOTAL	550.00

JOB# 2 CHARGES

LABOR

JOB#	TECH#	DATE	START	FINISH	ACT	TIME	TECH(S)	DESCRIPTION	HOURS
2	51CVZ						379		100.00
	379	04/04/16	15.10	15.10	0.00	0.00		FINISHED	
	379	04/04/16	0.00	0.00	0.00	0.00		FINISHED	
			TOTAL TECH TIME		0.00	0.00			

PERMA PLATE
PERF PERMA PLATE

JOB# 2 TOTALS

LABOR	100.00
JOB# 2 JOURNAL PREFIX CVIS	
JOB# 2 TOTAL	100.00

TOTALS

CONTROL#	ACCOUNT NUMBER	AMOUNT..
L8416		
		TOTAL LABOR 100.00
		TOTAL PARTS 0.00
		TOTAL SUBLET ... 550.00
		TOTAL G.O.G.... 0.00
		TOTAL MISC.CHG. 0.00
		TOTAL MISC.DISC 0.00
		TOTAL TAX..... 0.00
		TOTAL INVOICE \$ 650.00

APPROVED BY SIGNATURE



SOUTH COUNTY LINE-X

8864 Muraoka Drive
Gilroy, California 95020
(408) 842-8803 • Fax: (408) 842-8816

INVOICE • WORK ORDER

No. [Redacted]

Important Notice & Authorization

The Line-X liner is a permanent accessory. It is specifically stated that the product cannot be removed from the vehicle once sprayed on. The Line-X application process requires sanding and masking of the truck bed. Purchaser warrants the paint on his vehicle against damage due to application or removal of tape and Line-X hereby disclaims liability for damage caused. I hereby authorize the work described on work order to be done on my vehicle. You and your employees may operate my vehicle for the purpose of product fitting, cleaning, inspection, collection and delivery. Line-X will not be held responsible for loss or damage to the vehicle in case of fire, theft, accident or any other cause beyond your control. I have read and acknowledge receipt of the estimate for this work. An express mechanics lien is acknowledged on vehicle to secure the amount of work performed.

INITIALS _____

Damage Release Waiver

Line-X will not be held liable for damage to vehicles resulting from the Line-X application process. In addition, and without limiting the foregoing, purchaser expressly acknowledges the existence of the pre-existing damage to vehicle describer and release Line-X from any liability or loss in connection with such damage including and exacerbation of the described damage.

INITIALS _____

Warranty

Line-X will repair without charge, the bonded polyurethane linings, which under our examination, prove to be defective in material or workmanship. This warranty is valid only the Line-X liner has not been misused, abused or subject to excessive wear. The foregoing is in lieu of any other warranty or guarantee expressed or implied, and we are not responsible for any expense including removal, inconvenience, or consequential damage caused by items of our manufacture or sale. All linings purchased through Line-X must be returned to this applicator. This warranty is not transferable.

INITIALS _____

Inspected work done to satisfaction.

Date 4/5/2014 Contact _____
 Name _____
 Address _____
 City _____ State _____ Zip _____
 Phone (H) _____ (W) _____

HOW DID YOU HEAR ABOUT LINE-X?

- Referred by a friend
- Newspaper
- Yellow page ad
- Internet/Website (Corporate / Local)
- Promotional Show (Boat / Car / Other)
- Other _____

Make GMC Model 1500
 Year 2014 License No. _____
 VIN No. 1GTV20E03FZ [Redacted]
 Color _____ Miles _____

Payment Mastercard Visa Cash
 Check (No.) _____ DL No. _____
 P.O. No. 600477 R/O Stock No. _____

Damage Description _____

Description of Work _____

Color of Line-X <u>BLACK</u>		
<input checked="" type="checkbox"/> Under <input type="checkbox"/> Over Premium: <input type="checkbox"/> Yes <input type="checkbox"/> No		
Materials _____	<u>240</u>	<u>00</u>
Labor _____	<u>210</u>	<u>60</u>
Other Charges / Accessories _____		
Sub Total _____		
Allowances / Coupons / Discounts _____		
Tax _____		
TOTAL _____	<u>450</u>	<u>60</u>

Customer: I have read and everything is in satisfactory condition. ...

Customer Signature _____ Date: 4/5/14

Refrain from placing heavy objects on your new bedliner for the first 24 hours. If possible, leave tailgate down for first 24 hours.

Dealer Notification

Case Number: [REDACTED]

Activity Owner: TOCAMPO1

ACTIVITY INFORMATION

Status: Done

Created By: GZ4X1H

Contact: [REDACTED]

Created: 03/12/2018

End Date:

Documentation Required for CA CEC



I am requesting information from you. Please reply within 1 business day. This is a request for documentation only. Please do not reach out to the customer at this time. We have received a CA CEC case that pertains to one of our mutual customers. Please provide the following documentation: All sales, purchase and finance agreements, including a conversion invoice (if applicable) The incentives acknowledgement form Copy of the Title and Registration The Actual Cash Value statement of any trade All service and body shop repair orders including all internal, customer pay, and warranty repair orders. (Please include copies of both front and back of the documents). Please confirm if you are aware of any accidents or aftermarket modifications Please provide the needed information within 24 hours. Please provide documentation by attaching through the DCM tool, or sending to fax #586-920-0675. Please be aware there is a 10MB limit so documents may need to be uploaded in multiple uploads. Your cooperation in this matter is greatly appreciated as we are under strict timelines to respond to this matter. Thank you Ariana BRC CA CEC 1-866-790-5600 ext 5913743



T-216 P0002/0019 F-805
831-313-1537
Greenwood Chevrolet
04-09-'18 23:53 FROM-

THIS VALIDATED REGISTRATION CARD OR A FACSIMILE COPY IS TO BE KEPT WITH THE VEHICLE FOR WHICH IT IS ISSUED. THIS REQUIREMENT DOES NOT APPLY WHEN THE VEHICLE IS LEFT UNATTENDED. IT NEED NOT BE DISPLAYED. PRESENT IT TO ANY PEACE OFFICER UPON DEMAND. IF YOU DO NOT RECEIVE A RENEWAL NOTICE, USE THIS FORM TO PAY YOUR RENEWAL FEES OR NOTIFY THE DEPARTMENT OF MOTOR VEHICLES OF THE PLANNED NON-OPERATIONAL STATUS (PNO) OF A STORED VEHICLE. RENEWAL FEES MUST BE PAID ON OR BEFORE THE REGISTRATION EXPIRATION DATE OR PENALTIES WILL BE DUE PURSUANT TO CALIFORNIA VEHICLE CODE SECTIONS 9552 - 9554.

EVIDENCE OF LIABILITY INSURANCE FROM YOUR INSURANCE COMPANY MUST BE PROVIDED TO THE DEPARTMENT WITH THE PAYMENT OF RENEWAL FEES. EVIDENCE OF LIABILITY INSURANCE IS NOT REQUIRED WITH REGISTRATION RENEWAL OF OFF-HIGHWAY VEHICLES, TRAILERS, VESSELS, OR IF YOU FILE A PNO ON THE VEHICLE.

WHEN WRITING TO DMV, ALWAYS GIVE YOUR FULL NAME, PRESENT ADDRESS, AND THE VEHICLE MAKE, LICENSE, AND IDENTIFICATION NUMBERS.

***** DO NOT DETACH - REGISTERED OWNER INFORMATION *****



REGISTRATION CARD VALID FROM: 03/21/2016 TO: 03/31/2017

MAKE	YR MODEL	YR 1ST SOLD	VLP CLASS	TYPE VEH	TYPE LIC	LICENSE NUMBER
3MC	2015	2016	LW	31P	31	[REDACTED]
ODY TYPE MODEL	NP	NO	AX	WC	UNLADEN/G/ODV	VEHICLE ID NUMBER
PK	G	XR	2	E	05317	1GTV2UEC3F2 [REDACTED]
YR VEHICLE USE	DATE ISSUED	CC/ALCO	DT FEE RECVD	PIC	STICKER ISSUED	[REDACTED]
COMMERCIAL	04/04/16	35	04/04/16	4	[REDACTED]	[REDACTED]



AMOUNT PAID
\$ 534.00

AMOUNT DUE AMOUNT RCVD
\$ 534.00 CASH :
 CHCK : 534.00
 CRDT :

OWNER
BK STOCKTON
PO BX 1110

STOCKTON
CA 95201

STOCK # [REDACTED] CASHIER DATE LINE STAMP TI 35501 (533)

DATE FIRST SOLD AS A NEW VEHICLE (MM/DD/YYYY) 03/21/2016 DATE FIRST OPERATED (MM/DD/YYYY) 03/21/2016

MAKE GMC YEAR MODEL 2015 BODY TYPE PK MOTIVE POWER GAS NUMBER OF AXLES 2 UNLADEN WEIGHT 5317

VEHICLE IDENTIFICATION NUMBER 1GTV2UEC3F7 [REDACTED] M/C ENGINE NUMBER OR ADDITIONAL IDENTIFICATION NUMBER [REDACTED]

FOR CAMP TRAILERS AND TRAILER COACHES LENGTH IN INCHES [REDACTED] WIDTH IN INCHES [REDACTED]

SOLD TO: PRINT TRUE FULL NAME AS IT APPEARS ON DRIVER LICENSE OR ID CARD IN THE ORDER SHOWN BELOW

(1) [REDACTED] FIRST [REDACTED] MIDDLE [REDACTED] SUFFIX [REDACTED]

(2) [REDACTED] FIRST [REDACTED] MIDDLE [REDACTED] SUFFIX [REDACTED]

BUSINESS OR RESIDENCE ADDRESS [REDACTED] APT./STE. NO. [REDACTED] CITY [REDACTED] STATE [REDACTED] ZIP CODE [REDACTED]

APR. (OR LOCATION IF TRAILER COACH) [REDACTED] APT./STE. NO. [REDACTED] CITY [REDACTED] STATE [REDACTED] ZIP CODE [REDACTED]

LIENHOLDER OR LEGAL OWNER - PRINT TRUE FULL NAME (IF NONE, MUST PRINT "NONE" AND INITIAL) BK STOCKTON ELECTRONIC LIENHOLDER ELT# 1.08

BUSINESS OR RESIDENCE ADDRESS [REDACTED] APT./STE. NO. [REDACTED] CITY STOCKTON STATE CA ZIP CODE 95201

LESSEE ADDRESS - REQUIRED WHEN DIFFERENT FROM REGISTERED OWNER ABOVE [REDACTED] APT./STE. NO. [REDACTED] CITY [REDACTED] STATE [REDACTED] ZIP CODE [REDACTED]

If a passenger vehicle, will it be used for hire or to provide a service of transporting passengers in conjunction with a business? Yes No

APPLICANT'S CERTIFICATION: [REDACTED] I certify under the laws of the State of California that the foregoing is true and correct.

DATE 03/21/2016 BUYER (1) [REDACTED] (2) X [REDACTED]

CERTIFICATE OF COST - The dealer certifies that the vehicle entered in the Certificate of Cost is the vehicle that is physically attached to the vehicle, plus any trade-in allowance (exclude state or local taxes, insurance, etc.).

A - Cost of vehicle purchased as a: Complete vehicle Chassis only Cab and chassis DATE PURCHASED/ACQUIRED 03/21/2016

B - Cost of trailer coach including all permanently attached items (wall to wall carpeting, factory air conditioning, built-in appliances, etc.). ~~44000.00~~ 42000.00

ODOMETER DISCLOSURE STATEMENT

Federal and state law requires that you state the mileage upon transfer of ownership. Failure to complete or making a false statement may result in fines and/or imprisonment. The odometer reading is [REDACTED] [REDACTED] [REDACTED] [REDACTED] 30 (no tenths) miles, and to the best of my knowledge reflects the ACTUAL mileage unless one of the following statements is checked.

WARNING - Is NOT the actual mileage. Mileage EXCEEDS the odometer mechanical limits.

I/we certify (or declare) that the foregoing is true and correct.

DATE 03/21/2016 GREENWOOD CHEVROLET COMPANY AGENT [REDACTED]

DATE 03/21/2016 BUICK GMC COMPANY AGENT [REDACTED]

REG 397 (REV 11/2016) LOIS R MARTINEZ

DEALER'S NUMBER 51491

- DMV copy -

CERTIFICATE OF ORIGIN FOR A VEHICLE

45110

8488



RBLPD019

INVOICE NO.

DATE
06/15/15

VEHICLE IDENTIFICATION NO.
1GTV2UEC3FZ

YEAR
2015

MAKE
GMC TRUCK

BODY TYPE
SIERRA 4WD EXT CAB PICKUP

SHIPPING WEIGHT
5317

H.P. (S.A.E.)

G.V.W.T.

NO. CYLS.

SERIES OR MODEL

45.7

7200

08

TK15753

N.T.R.
1/2

I, the undersigned/authorized representative of the company, firm or corporation named below, hereby certify that the new vehicle described above is the property of the said company, firm or corporation and is transferred on the above date and under the Invoice Number indicated to the following distributor or dealer.

NAME OF DISTRIBUTOR, DEALER, ETC.

44368 SMWRKS

EDMARK CHEVROLET CADILLAC BUICK GMC

15700 IDAHO CENTER BLVD

NAMPA

ID 83687-4179

It is further certified that this was the first transfer of such new vehicle in ordinary trade and commerce.

* THIS VEHICLE *
* HAS A *
* 50-STATE *
* EMISSION *
* SYSTEM *

GENERAL MOTORS LLC

BY:

(SIGNATURE OF AUTHORIZED REPRESENTATIVE)

(AGENT)

DETROIT

MI 48243-1114

CITY - STATE

GM 521 REV. 10-05

MAR 29 2016 *ROS 03/16 05*

Decision: Funded by Bank of Stockton on 03/25/2016 - 11:40 AM

Dealership Name : GREENWOOD CHEVROLET		FS App #: 113063
Dealership Number:	[REDACTED]	Analyst: Bank of Stockton Credit Buyer
RouteOne App # :	01 [REDACTED]	Analyst Phone: 800-399-5626
Submitted by:	JIMFINK01 on 03/21/2016 - 11:28 AM	
Applicant Name:	[REDACTED]	

Deal Recap	Decision	Application
Transaction Type	Retail	Retail
Vehicle	2015 GMC Sierra 1500	2015 GMC Sierra 1500
Tier	A	
Financed Amount	\$43,768.23	\$38,904.00 Δ
Cash Down		\$0.00
Total Down	\$7,000.00	\$7,000.00
Total Monthly Payment	\$599.01	\$531.59 Δ
Term	84	84
Wholesale/Invoice		\$45,710.00
Customer Rate		3.99%
Buy Rate	2.79%	
Total Lender Fees	\$0.00	

Additional Deal Information	Decision	Application
Sales Price		\$41,710.00
Doc Fee		\$80.00
Rebate		\$6,500.00
Credit Disability		\$0.00
Credit Life		\$0.00
GAP		\$0.00
Svc Contract		\$0.00
New/Used		NEW
VIN		1GTV2UEC3FZ [REDACTED]
Mileage		10
MSRP		\$42,370.00

Comments

LTV Grid

Documentation/Funding Details	Decision
Contract Id	113063
Funding Analyst Name / Phone / Fax	[REDACTED]
Status Date	03/25/2016
Amount Financed	\$43,768.23 <i>205 33562</i>
Customer Rate	3.99%
Buy Rate	2.79%
Reserve Amount and Type	\$1520.76;Portion

SALES SUMMARY *COM 8.5*

629P

SALE No. [REDACTED] BY EUGENE A ANDRADE DATE: 03/21/2016 UNIT: NEW 2015 GMC STERRA 1 STK No. [REDACTED]
 BUYER [REDACTED] 1GTV2UEC3FZ [REDACTED]
 SALESPERSON: ZACHARY HEADLEY 386 SALESPERSON: MGR:

PRICE:	\$ 41710.00
COST:	\$ 41035.01
SUB TOTAL:	\$ 674.99
OVER ALLOWANCE:	\$ 500.00
ADDITIONS:	<i>- 125 FROM 8/10/16 sales</i>
ADDITIONS:	<i>- 65 dev fee & gas</i>
ADDITIONS:	<i>795 - 219 = Pplate</i>
ADDITIONS:	N/A
ADDITIONS:	N/A
ADDITIONS:	N/A
TOTAL ADDITIONS:	N/A
NET GROSS VEHICLE GROSS:	\$ 1174.99
PACK:	\$ 400.00
GROSS COMM. GROSS PAYABLE:	\$ 774.99
AFTR MKT:	\$ 1345.00
RESERVE:	\$ 6548.61
CREDIT LIFE:	N/A
A & H:	N/A
WARRANTY:	\$ 2501.00
COLISION GAP:	\$ 895.00
TOTAL F & I:	\$ 4028.34
SUB TOTAL:	\$ 5203.33
TOTAL COMMISSION:	\$ 280.00
NET PROFIT:	\$ 4923.33

TRADE INFORMATION

YEAR: 2000	MAKE: DODGE TRUCK
MODEL: RAM 1500	VIN: 1B7HC16X5S [REDACTED]
LIC. NO. [REDACTED]	ACV: 1000.00
NET PAYOFF: N/A	HIGH: LOW:
GOOD UNTIL:	
PAYOFF TO:	

LOAN INFORMATION

DOWN PAYMENT	ADVANCE
TRADE 500.00 CASH 6500.00 UNDER	OVER
HOLD FOR <input type="checkbox"/> SENT TO <input type="checkbox"/> MONEY IN <input type="checkbox"/> 1 PAY DUE	
LEGAL TO BE: BK STOCKTON PO BX 1110 STOCKTON CA 95201	

PAY VOUCHER

SALESPERSON: ZACHARY HEADLEY 386 STK No. [REDACTED] MAKE-MODEL: NEW 2015 GMC DATE: 03/21/16
 BUYER: [REDACTED] STERRA 150 1GTV2UEC3FZ [REDACTED]
 COMMISSION: FRONT-END: 280.00 PAY
 BACK-END: N/A HOLD FOR
 SPIFF: N/A
 GROSS PYBL: 774.99
 TOTAL COMMISSION: 280.00

PAY VOUCHER

SALESPERSON: [REDACTED] STK No. [REDACTED] MAKE-MODEL: NEW 2015 GMC DATE: 03/21/16
 BUYER: [REDACTED] STERRA 150 1GTV2UEC3FZ [REDACTED]
 COMMISSION: FRONT-END: N/A PAY
 BACK-END: N/A HOLD FOR
 SPIFF: N/A
 GROSS PYBL: 774.99
 TOTAL COMMISSION: N/A



California Proof of Insurance Card

Financial Indemnity Company

A part of **Kemper Specialty**

This insurance policy meets the requirements of California Vehicle Code Section 16056 or 16500.5

Name and Address of Policyholder [REDACTED]		Insurance Company Financial Indemnity Company PO BOX 223687 Dallas, TX 75222-3687 NAIC No. 19852 For Claims, contact us at (800) 234-3606	
Drivers: [REDACTED]		Insured Vehicle(s) Year / Make / Model / VIN 2000 DODGE RAM 1B7HC16X5YS [REDACTED] 2009 MAZDA MAZDA6 1YVHP81A795 [REDACTED]	
Broker INCORPORATED INSURANCE SERVICE 13636 BURBANK BLVD SHERMAN OAKS CA 91401 877-210-9514			
Policy Number [REDACTED]			
Policy Effective Date 09/04/2015		Policy Expiration Date 09/04/2016	

U-400 (04/12)

FORM: SDOCS.IDCARD

Copyright 2012 Kemper Corp.

04UTN631801

INSTRUCTIONS IN CASE OF ACCIDENT OR LOSS
REPORT ALL ACCIDENTS IMMEDIATELY - 24 HOURS A DAY, SEVEN DAYS A WEEK

- Call the police.
- Obtain full names, addresses, phone numbers and license numbers of all persons involved.
- Obtain full names, addresses and phone numbers of witnesses.
- Provide the insurance information found on this Proof of Insurance Card, but do not disclose your policy limits.
- Do not admit fault or discuss the accident with anyone except the police or a representative of your insurance company.
- As soon as possible, report the accident on our website at kemperspecialty.com or call **Loss Report Unit at (888) 253-7834**, 24 hours a day, seven days a week. Our mailing address is PO BOX 223687, Dallas, TX 75222-3687. Our customer service number is (800) 234-3606.



CUSTOMER NAME [REDACTED]

VIN: 1 / G / T / V / Z / U / F / C / B / F / [REDACTED]

Customer Incentive Acknowledgement

1. Customer Incentive

I assign the total amount of customer incentive(s) listed to the dealer named below and request that the available customer incentive(s) be applied: (a) XX to the down payment of this vehicle, (b) ___ where permissible by law, as a price reduction (Bill of Sale indicates pre-incentive price, amount of incentive, and final price with incentive applied), or c) ___ a check be issued in my name by Dealer named below:

Incentive Program Reference	Amount	GM Incentive Code
CCP	\$ 1500.00	NCC
GM TRADE IN	\$ 2000.00	JXS
GM INCR CC	\$ 1000.00	LJR
BONUS CASH	\$ 2000.00	JPP
N/A	\$ N/A	N/A
Total Incentive Amount Received	\$ 6500.00	

2. Other Program Selection (Which may or may not be in lieu of customer allowance programs; for example, Division supported financing/leasing, etc.)

I elect to receive the following in lieu of _____ AND/OR

I elect to receive _____

Vehicle Incentive Acknowledgment. I am the ultimate purchaser or lessee of the vehicle bearing this vehicle identification number, which was sold/leased to me by the Dealer, named below. This vehicle was purchased/leased for personal/business use and not resale and I took delivery on 03 21 16. I acknowledge receipt of incentive(s) as described in Item(s) ___ and release GM from any future claim or obligation for incentive(s) on t

Purchaser/Lessee Signature [REDACTED] Date: 03 21 16

OnStar Acknowledgement

Vehicle Software Acknowledgement

I agree not to reverse engineer, decompile or copy any of the software in my vehicle (unless otherwise expressly permitted) and agree not to defeat or attempt to defeat any security mechanism in the vehicle software systems.

OnStar Terms and Conditions Acknowledgement

I acknowledge that I have received the Terms and Conditions applicable to the OnStar Services. Copies are available in my vehicle glove box, from my dealer, at www.onstar.com or by contacting OnStar directly.

Cancellation of OnStar Services

I acknowledge that the OnStar services are provided under a continuous service contract that will remain in effect until cancelled by me or OnStar. I understand that to request cancellation of OnStar services, I must press the blue OnStar button in my car or call 1.888.4ONSTAR.

Payment Methods

Unless I indicate otherwise to OnStar, I understand that if I provide OnStar with my credit or debit card information at any time, it will be kept securely on file and will be automatically charged when payment from OnStar Plan becomes due (at the then current rate). Notice of the payment due date, the monthly amount due and my credit or debit card information will be provided at least 30 days prior to any charges. Current pricing and terms can be found at www.onstar.com.

Purchaser/Lessee Signature [REDACTED] Date: 03 21 16

The undersigned person, as _____, certifies that the information on this application is true and correct and the Incentive Payments, OnStar Vehicle Software; OnStar Terms and Conditions; Cancellation of OnStar Services and Payment Method disclosures have been provided to the said purchaser/lessee who has taken delivery of the referenced unit through this dealership and that properly completed accurate delivery data has been forwarded to General Motors.

Authorized Dealer Signature [REDACTED] Date: 03 21 16
Dealership Name: GREENWOOD [REDACTED] Dealer Code [REDACTED]

Dealer Note: This is a required document and it must be completed, signed, and retained in EVERY DEAL FILE for all customers even if there are no incentives or rate support available. A copy of the completed form should be provided to the customer. GM-3795-OS Rev 10-15-2010



A3AC [REDACTED]

WARRANTY REGISTRATION FORM APPEARANCE PROTECTION

VEHICLE OWNER INFORMATION

NAME [REDACTED]
ADDRESS [REDACTED]
CITY / STATE / ZIP [REDACTED]
HOME / WORK / CELL PHONE #: [REDACTED]
EMAIL [REDACTED]

SELLING DEALER INFORMATION

NAME GREENWOOD CHEVROLET BUICK GMC
ADDRESS 270 SAN FELIPE ROAD HOLLISTER CA 95023
DEALER AUTHORIZED NAME AND SIGNATURE EUGENE ANDRADE

VEHICLE INFORMATION

YEAR / MAKE / MODEL 2015 GMC SIERRA 1500
CURRENT ODOMETER 30 NEW USED DEMO
VEHICLE IDENTIFICATION NUMBER 1GTV2UEC3FZ [REDACTED]
APP PURCHASE PRICE \$ 795.00
PURCHASE DATE 03/21/2016

WARRANTY REGISTRATION: This Warranty registration form must be completed and submitted to Administrator within thirty (30) days from the latter of: the date of purchase of the vehicle or the date of product application. This Warranty applies only to the products that have been applied to the vehicle at the time of Warranty registration. Administrator assumes no liability for the failure of the dealer to submit this Warranty on behalf of the vehicle owner. To verify that the Warranty has been submitted and accepted, vehicle owner may contact Administrator at the telephone number and mailing address listed below or at www.permaplate.com.

SPECIFIC WARRANTY COVERAGE FOR PRODUCT IS SET FORTH ON THE REVERSE SIDE

COVERAGE OPTIONS AND TERM SELECTION

APPEARANCE PROTECTION PROGRAM (APP)

Paintguard®, Fiberguard® and Leatherguard®

3 Year 5 Year 7 Year (New only)

IF APP IS PURCHASED AND NO TERM BOX IS CHECKED, MAXIMUM TERM WILL APPLY

*****NOTIFY ADMINISTRATOR OF COVERED DAMAGE WITHIN 30 DAYS;
FAILURE TO DO SO WILL RESULT IN CLAIM DENIAL.*****

VEHICLE OWNER SIGNATURE [REDACTED]

GAP NUMBER: GPK- [REDACTED]



**Guaranteed Auto Protection
GAP Advantage Program
Debt Waiver Addendum
ENROLLMENT**

This Guaranteed Auto Protection (GAP) Debt Waiver Addendum ("Addendum") amends Your retail installment sales/loan/lease contract ("Finance Contract").

RETAIL INSTALLMENT SELLER ("Dealer/Creditor")
 GREENWOOD CHEVROLET BUICK GMC
 PHONE NO.
 831 637 - 5328
 MAILING ADDRESS
 270 SAN FELIPE ROAD
 CITY STATE ZIP
 HOLLISTER CA 95023

BUYER OR LESSEE ("You" or "Your")
 PHONE NO.
 MAILING ADDRESS
 CITY STATE ZIP

FINANCIAL INSTITUTION ("Lender")
 BANK STOCKTON
 MAILING ADDRESS
 PO BOX 1310

PHONE NO.
 CITY STATE ZIP

AGREEMENT TYPE AND COVERAGE PERIOD	CONTRACT TERM* (MONTHS)	PURCHASE	GAP ISSUE DATE DAY/MONTH/YEAR	SALE MILEAGE	GAP ADDENDUM PURCHASE PRICE
	84	LEASE			
COVERED VEHICLE DESCRIPTION	YEAR	MAKE	MODEL	VEHICLE IDENTIFICATION NUMBER	
	2015	GMC	SILVERADO 1500	1G1YV2UE6317 [REDACTED]	
VALUE OF COLLATERAL	MSRP/NADA VALUE	MONTHLY PAYMENT	FINANCED AMOUNT OR LEASE NET CAPITALIZED COST		
	RETAIL VALUE \$ 43055.00	\$ 599.01	\$ 43768.23		
ALTERNATE FINANCING <input type="checkbox"/>		RESIDUAL VALUE \$			

*Maximum Contract Term cannot exceed 84 months and value of collateral cannot exceed \$100,000.

By signing below, You acknowledge that You have read and understand the provisions contained in this Addendum including State Provisions on the back and that You are not relying on any other writings or any other representations or promises other than those within this Addendum. If any of the information shown in the registration section is in error, You must contact the GAP Program Administrator immediately. The GAP Program Administrator will make any appropriate changes by endorsement to this Addendum and will immediately forward a copy of the endorsement to You via first-class mail. In the event of a Total Loss, You are responsible for notifying Your Primary Automobile Insurance Company and the GAP Program Administrator. See "How to Submit a Claim" for additional information. By signing below, You accept this contract.

Information shown above
 DATE 3/21/16
 DATE 3/21/16

ELIGIBILITY LIMITS: You may purchase this Addendum only at the time the Finance Contract is executed. This Addendum may not be attached to a Finance Contract under which: (a) the financed amount or lease capitalized cost exceeds \$100,000 or 150% of the Manufacturer's Suggested Retail Price ("MSRP") for a new vehicle or 150% of the National Automobile Dealers Association ("NADA") Official Used Car Guide retail value for a used vehicle, (b) the purchase price or lease capitalized cost or the MSRP for a new vehicle or the NADA retail value for a used vehicle exceeds \$100,000, or (c) the Finance Contract term exceeds 84 months.

ELECTION: You have elected to purchase this Addendum for a separately stated charge. You may, at Your option, purchase GAP protection from the Lender or another source that is acceptable to the Lender. This Addendum is not automobile insurance, nor does this Addendum fulfill any requirements of any financial responsibility laws. You understand that GAP benefits under this Addendum decrease over the term of the Finance Contract and that some provisions within this Addendum may restrict or limit these benefits. You agree to maintain automobile physical damage and collision coverage through Your Primary Automobile Insurance Company for the full term of this Addendum, as required by the terms of the Finance Contract. Your purchase of this Addendum is strictly voluntary and is not required for the buyer to obtain an extension of credit. Additionally, Your purchase of this Addendum will not be a factor in the credit approval process.

Your Credit Score and the Price You Pay for Credit

Applicant	[REDACTED]
------------------	------------

Your Credit Score

Your credit score	[REDACTED]
	Source: EXPERIAN Date: 03/21/2016
	Source: Date:
	Source: Date:

Understanding Your Credit Score

What you should know about credit scores	<p>Your credit score is a number that reflects the information in your credit report.</p> <p>Your credit report is a record of your credit history. It includes information about whether you pay your bills on time and how much you owe to creditors.</p> <p>Your credit score can change, depending on how your credit history changes.</p>
---	--

How we use your credit score	Your credit score can affect whether you can get a loan and how much you will have to pay for that loan.
-------------------------------------	--

The range of scores	<p>Scores range from a low of [REDACTED] to a high of [REDACTED] for EXPERIAN .</p> <p>Scores range from a low of [REDACTED] to a high of [REDACTED] for [REDACTED] .</p> <p>Scores range from a low of [REDACTED] to a high of [REDACTED] for [REDACTED] .</p> <p>Generally, the higher your score, the more likely you are to be offered better credit terms.</p>
----------------------------	---

How your score compares to the scores of other consumers	<p>Your credit score from EXPERIAN ranks higher than [REDACTED] percent of U.S. consumers.</p> <p>Your credit score from [REDACTED] ranks higher than [REDACTED] percent of U.S. consumers.</p> <p>Your credit score from [REDACTED] ranks higher than [REDACTED] percent of U.S. consumers.</p>
---	--

Signature

[REDACTED]

Date: 3-21-16

Checking Your Credit Report**What if there are mistakes in your credit report?**

You have a right to dispute any inaccurate information in your credit report. If you find mistakes on your credit report, contact the consumer reporting agency.

It is a good idea to check your credit report to make sure the information it contains is accurate.

How can you obtain a copy of your credit report?

Under federal law, you have the right to obtain a free copy of your credit report from each of the nationwide consumer reporting agencies once a year.

To order your free annual credit report -

By telephone: Call toll-free: 1-877-322-8228

On the web: Visit www.annualcreditreport.com

By mail: Mail your completed Annual Credit Report Request Form (which you can obtain from the Federal Trade Commission's web site at

Annual Credit Report Request Service
P.O. Box 105281
Atlanta, GA 30348-5281

How can you get more information?

For more information about credit reports and your rights under federal law, visit the Federal Reserve Board's web site at www.federalreserve.gov, the Federal Trade Commission's web site at www.ftc.gov, or the Consumer Financial Protection Bureau's web site at www.consumerfinance.gov/learnmore.

**RETAIL INSTALLMENT SALE CONTRACT - SIMPLE FINANCE CHARGE
(WITH ARBITRATION PROVISION)**

Buyer Number _____ Contract Number _____ R.O.S. Number _____ Stock Number _____

Buyer Name and Address (Including County and Zip Code)	Co-Buyer Name and Address (Including County and Zip Code)	Seller-Creditor (Name and Address)
[REDACTED]	N/A	GREENWOOD CHEVROLET BUICK GMC 270 SAN FELIPE ROAD HOLLISTER CA 95023 SAN BENITO

u, the Buyer (and Co-Buyer, if any), may buy the vehicle below for cash or on credit. By signing this contract, you choose to buy the vehicle on credit under the terms and conditions on the front and back of this contract. You agree to pay the Seller - Creditor (sometimes "we" or "us" in this contract) the Amount Financed and Finance Charge in U.S. funds according to the payment schedule below. We will figure your finance charge on a daily basis. The Truth-In-Lending Disclosures below are part of this contract.

New Used	Year	Make and Model	Odometer	Vehicle Identification Number	Primary Use For Which Purchased
NEW	2015	GMC SIERRA 1500	30	1GTVZUEC3FZ [REDACTED]	<input type="checkbox"/> Personal, family or household unless otherwise indicated below. <input type="checkbox"/> business or commercial

ANNUAL PERCENTAGE RATE	FINANCE CHARGE	Amount Financed	Total of Payments	Total Sale Price
The cost of your credit as a yearly rate.	The dollar amount the credit will cost you.	The amount of credit provided to you or on your behalf.	The amount you will have paid after you have made all payments as scheduled.	The total cost of your purchase on credit, including your down payment of \$7000.00
3.99 %	\$ 6548.61 (e)	\$ 43768.23	\$ 50316.04 (e)	\$ 57316.04 (e)

(e) means an estimate

Number of Payments:	Amount of Payments:	When Payments Are Due:
One Payment of N/A	N/A	N/A
One Payment of N/A	N/A	N/A
One Payment of N/A	N/A	N/A
83	599.01	Monthly beginning 05/05/2016
N/A	N/A	N/A
One final payment	599.01	DUE ON 04/05/2023

Late Charge. If payment is not received in full within 10 days after it is due, you will pay a late charge of 5% of the part of the payment that is late.
Prepayment. If you pay off all your debt early, you may be charged a minimum finance charge.
Security Interest. You are giving a security interest in the vehicle being purchased.
Additional Information: See this contract for more information including information about nonpayment, default, any required repayment in full before the scheduled date, minimum finance charges, and security interest.

1. Total Cash Price	\$ 42260.00 (A)
A. Cash Price of Motor Vehicle and Accessories	\$ 41710.00
1. Cash Price Vehicle	\$ 550.00
2. Cash Price Accessories	\$ _____
3. Other (Nontaxable)	\$ _____
Describe	N/A
Describe	N/A
B. Document Processing Charge (not a governmental fee)	\$ 30.00 (B)
C. Emissions Testing Charge (not a governmental fee)	\$ _____ (C)
D. (Optional) Theft Deterrent Device (to whom paid)	\$ _____ (D)
E. (Optional) Theft Deterrent Device (to whom paid)	\$ _____ (E)
F. (Optional) Theft Deterrent Device (to whom paid)	\$ _____ (F)
G. (Optional) Surface Protection Product (to whom paid)	\$ 795.00 (G)
H. (Optional) Surface Protection Product (to whom paid)	\$ _____ (H)
I. EV Charging Station (to whom paid)	\$ 3665.00 (I)
J. Sales Tax (on taxable items in A through I)	\$ _____ (J)

STATEMENT OF INSURANCE
 NOTICE. No person is required as a condition of financing the purchase of a motor vehicle to purchase or negotiate any insurance through a particular insurance company, agent or broker. You are not required to buy any other insurance to obtain credit. Your decision to buy or not buy other insurance will not be a factor in the credit approval process.

Term	Exp	Premium
\$ N/A	Term	\$ N/A
\$ N/A	Ded. Comp., Fire & Theft	\$ N/A
\$ N/A	Ded. Collision	\$ N/A
\$ N/A	Bodily Injury Limits	\$ N/A
\$ N/A	Property Damage Limits	\$ N/A
\$ N/A	Medical	\$ N/A
\$ N/A		\$ N/A
Total Vehicle Insurance Premiums		\$ _____ (a)

UNLESS A CHARGE IS INCLUDED IN THIS AGREEMENT FOR PUBLIC LIABILITY OR PROPERTY DAMAGE INSURANCE, PAYMENT FOR SUCH COVERAGE IS NOT PROVIDED BY THIS AGREEMENT.

You may buy the physical damage insurance this contract requires (see below) for a charge of _____ per month.
 Buyer _____
 Co-Buyer _____
 Seller _____

If any insurance is checked below, policies or certificates from the named insurance companies will describe the terms and conditions.

<input type="checkbox"/> Credit Life:	<input type="checkbox"/> Buyer	<input type="checkbox"/> Co-Buyer	<input type="checkbox"/> Both
<input type="checkbox"/> Credit Disability (Buyer Only)			
Credit Life	Term	Exp	Premium
Credit Disability	N/A	N/A	\$ N/A
Total Credit Insurance Premiums	\$ _____ (b)		
Insurance Company Name	N/A		
Home Office Address	N/A		

Credit life insurance and credit disability insurance are not required to obtain credit. Your decision to buy or not buy credit life and credit disability insurance will not be a factor in the credit approval process. They will not be provided unless you sign and agree to pay the extra cost. Credit life insurance is based on your original payment schedule. This insurance may not pay all you owe on this contract if you make late payments. Credit disability insurance does not cover any increase in your payment or in the number of payments. Coverage for credit life insurance and credit disability insurance ends on the original due date for the last payment unless a different term for the insurance is shown above.
 You are applying for the credit insurance marked above. Your signature below means that you agree.

Governmental fee (to whom paid) _____ \$ 29.00 (K)

L. (Optional) Service Contract (to whom paid) CNA NATIONAL \$ 2001.00 (L)

M. (Optional) Service Contract (to whom paid) N/A \$ N/A (M)

N. (Optional) Service Contract (to whom paid) N/A \$ N/A (N)

O. (Optional) Service Contract (to whom paid) N/A \$ N/A (O)

P. (Optional) Service Contract (to whom paid) N/A \$ N/A (P)

Q. Prior Credit or Lease Balance paid by Seller to _____ (e) \$ N/A (Q)

(see downpayment and trade-in calculation)

R. (Optional) Gap Contract (to whom paid) CNA GAP ADVANTAGE \$ 895.00 (R)

S. (Optional) Used Vehicle Contract Cancellation Option Agreement \$ N/A (S)

T. Other (to whom paid) _____ \$ N/A (T)

For _____

Total Cash Price (A through T) \$ 50226.48 (1)

Amounts Paid to Public Officials ESTIMATED

A. Vehicle License Fees \$ 280.00 (A)

B. Registration/Transfer/Titling Fees \$ 253.50 (B)

C. California Tire Fees \$ 8.75 (C)

D. Other \$ N/A (D)

Total Official Fees (A through D) \$ 541.75 (2)

Amount Paid to Insurance Companies (Total premiums from Statement of Insurance column a + b) \$ N/A (3)

State Emissions Certification Fee or State Emissions Exemption Fee \$ N/A (4)

Subtotal (1 through 4) \$ 80766.23 (5)

Total Downpayment

A. Agreed Trade-In Value, Yr 2000 Make DODGE TRUCK \$ 500.00 (A)

Model RAM 1500

VIN 1B7HR16X5T _____

B. Less Prior Credit or Lease Balance (e) \$ N/A (B)

C. Net Trade-In (A less B) (indicate if a negative number) \$ 500.00 (C)

D. Deferred Downpayment \$ N/A (D)

E. Manufacturer's Rebate \$ 5500.00 (E)

F. Other \$ N/A (F)

G. Cash \$ N/A (G)

Total Downpayment (C through G) \$ 7000.00 (6)

If negative, enter zero on line 6 and enter the amount less than zero as a positive number on line 1Q above)

Amount Financed (5 less 6) \$ 43768.23 (7)

Your signature below means that you agree that: (1) You are not eligible for insurance if you have reached your 65th birthday. (2) You are eligible for disability insurance only if you are working for wages or profit 30 hours a week or more on the Effective Date. (3) Only the Primary Buyer is eligible for disability insurance. DISABILITY INSURANCE MAY NOT COVER CONDITIONS FOR WHICH YOU HAVE SEEN A DOCTOR OR CHIROPRACTOR IN THE LAST 6 MONTHS (Refer to "Total Disabilities Not Covered" in your policy for details). You want to buy the credit insurance.

Date _____ Buyer Signature _____ Age _____

Date _____ Co-Buyer Signature _____ Age _____

OPTIONAL GAP CONTRACT A gap contract (debt cancellation contract) is not required to obtain credit and will not be provided unless you sign below and agree to pay the extra charge. If you choose to buy a gap contract, the charge is shown in item 1R of the Itemization of Amount Financed. See your gap contract for details on the terms and conditions it provides. It is a part of this contract.

Term _____ Mos. Name of Gap Contract CNA GAP ADVANTAGE

I want to buy _____

Buyer Sign _____

OPTIONAL purchase the service contract(s) written with the following company(ies) for the term(s) shown below for the charge(s) shown in item 1L, 1M, 1N, 1O, and/or 1P.

CNA NATIONAL

1L Company \$ _____

Term _____ Mos. or _____ Miles

1M Company \$ _____

Term _____ Mos. or _____ Miles

1N Company \$ _____

Term _____ Mos. or _____ Miles

1O Company \$ _____

Term _____ Mos. or _____ Miles

1P Company \$ _____

Term _____ Mos. or _____ Miles

Buyer Sign _____

Co-Buyer Sign _____

HOW THIS CONTRACT CAN BE CHANGED. This contract contains the entire agreement between you and us relating to this contract. Any change to the contract must be in writing and both you and we must sign _____

Buyer Sign _____

Co-Buyer Sign _____

SELLER ASSISTED LOAN

I MAY BE REQUIRED TO PLEDGE SECURITY FOR THE LOAN, AND I AM OBLIGATED FOR THE INSTALLMENT PAYMENTS ON BOTH THIS SELLER ASSISTED LOAN AND THE LOAN.

Interest of Loan From _____

Finance Charge \$ _____

Payable in _____

Payments of \$ _____

This Loan is shown in item 6D.

AUTO BROKER FEE DISCLOSURE

If this contract reflects the retail sale of a new motor vehicle, the sale is not subject to a fee received by an autobroker from us unless the following box is checked:

Name of autobroker receiving fee, if applicable: _____

Buyer sign here, the provisions of the Seller's Right to Cancel section on the back giving the Seller the right to cancel if Seller is unable to _____

X _____

Co-Buyer _____

Agreement to Arbitrate: By signing below, you agree that _____ the Arbitration Provision on the reverse side of this contract, you or we may elect to resolve any dispute by neutral arbitration. For additional information concerning the agreement to arbitrate. _____

Co-Buyer Signs X _____

You pay no finance charge if the Amount Financed, item 7, is paid in full on or before _____, Year _____

SELLERS INITIALS _____

MINIMUM PUBLIC LIABILITY INSURANCE LIMITS PROVIDED IN LAW MUST BE MET BY EVERY PERSON WHO PURCHASES A VEHICLE. IF YOU ARE UNSURE WHETHER OR NOT YOUR CURRENT INSURANCE POLICY WILL COVER YOUR NEWLY ACQUIRED VEHICLE IN THE EVENT OF AN ACCIDENT, YOU SHOULD CONTACT YOUR INSURANCE AGENT.

YOUR PRESENT POLICY MAY NOT COVER COLLISION DAMAGE OR MAY NOT PROVIDE FOR FULL REPLACEMENT COSTS FOR THE VEHICLE BEING PURCHASED. IF YOU DO NOT HAVE FULL COVERAGE, SUPPLEMENTAL COVERAGE FOR COLLISION DAMAGE MAY BE AVAILABLE TO YOU THROUGH YOUR INSURANCE AGENT OR THROUGH THE SELLING AGENT. HOWEVER, UNLESS OTHERWISE SPECIFIED, THE COVERAGE YOU OBTAIN THROUGH THE DEALER PROTECTS ONLY THE DEALER, USUALLY UP TO THE AMOUNT OF THE CASH BALANCE REMAINING AFTER THE VEHICLE HAS BEEN REPOSSESSED AND SOLD.

IN THE EVENT OF LOSS OR DAMAGE TO YOUR VEHICLE, YOU SHOULD CONTACT YOUR INSURANCE AGENT. YOU SHOULD READ AND UNDERSTAND THESE PUBLIC LIABILITY TERMS AND CONDITIONS.

X _____

Trade-In Payoff Agreement: Seller relied on information from you and/or the lienholder or lessor of your trade-in vehicle to arrive at the payoff amount shown in item 6B of the Itemization of Amount Financed in the "Prior Credit or Lease Balance." You understand that the amount quoted is an estimate.

Seller agrees to pay the payoff amount shown in 6B to the lienholder or lessor of the trade-in vehicle, or its designee. If the actual payoff amount is more than the amount shown in 6B, you must pay the Seller the excess on demand. If the actual payoff amount is less than the amount shown in 6B, Seller will refund to you any overage Seller receives from your prior lienholder or lessor. Except as stated in the "NOTICE" on the back of this contract, the Seller will not refund the Prior Credit or Lease Balance shown in 6B or any refund.

Buyer Signature _____ Co-Buyer Signature X _____

Notice to buyer: (1) Do not sign this agreement before you read it or if it contains any blank spaces to be filled in. (2) You are entitled to a completely filled copy of this agreement. (3) You can prepay the full amount due under this agreement at any time. (4) If you default in the performance of your obligations under this agreement, the vehicle may be repossessed and you may be subject to suit and liability for the unpaid indebtedness evidenced by this agreement.

If you have a complaint concerning this sale, you should try to resolve it with the seller. Complaints concerning unfair or deceptive practices or methods by the seller may be referred to the city attorney, the district attorney, or an investigator for the Department of Motor Vehicles, or any combination thereof.

After this contract is signed, the seller may not change the financing or payment terms unless you agree in writing to the change. You do not have to agree to any change, and it is an unfair or deceptive practice to do so.

Buyer Signature X _____ Co-Buyer Signature X _____

The Annual Percentage Rate may be negotiable with the Seller. The Seller may assign this contract and retain its right to receive a part of the Finance Charge.

THERE IS NO COOLING-OFF PERIOD UNLESS YOU OBTAIN A CONTRACT CANCELLATION OPTION

California law does not provide for a "cooling-off" or other cancellation period for vehicle sales. Therefore, you cannot later cancel this contract simply because you change your mind, decide the vehicle costs too much, or wish you had acquired a different vehicle. After you sign below, you may only cancel this contract with the agreement of the seller or for legal cause, such as fraud. However, California law does require a seller to offer a two-day contract cancellation option on used vehicles with a purchase price of less than forty thousand dollars (\$40,000), subject to certain statutory conditions. This contract cancellation option requirement does not apply to the sale of a recreational vehicle, a motorcycle, or an off-highway motor vehicle.

YOU AGREE TO THE TERMS OF THIS CONTRACT. YOU CONFIRM THAT BEFORE YOU SIGNED THIS CONTRACT, WE GAVE IT TO YOU, AND YOU WERE FREE TO TAKE IT AND REVIEW IT. YOU ACKNOWLEDGE THAT YOU HAVE READ BOTH SIDES OF THIS CONTRACT, INCLUDING THE ARBITRATION PROVISION ON THE REVERSE SIDE, BEFORE SIGNING BELOW. YOU CONFIRM THAT YOU RECEIVED A COMPLETELY FILLED-IN COPY WHEN YOU SIGNED IT.

Buyer Signature X _____ Date 03/21/16 _____ Co-Buyer Signature X _____ Date _____

Co-Buyers and Other Owners: Co-Buyers and Other Owners are responsible for paying the entire debt. An other owner is a person whose name is on the title to the vehicle but does not have to pay the debt. The other owner agrees to give us a security interest in the vehicle given to us in this contract.

Other Owner Signature X _____ Address _____

GUARANTY: To induce us to sell the vehicle to Buyer, each person who signs as a Guarantor individually guarantees the payment of this contract. If Buyer fails to pay any money owing on this contract, each Guarantor must pay it when asked. Each Guarantor will be liable for the total amount owing even if other persons also sign as Guarantor, and even if Buyer has a complete defense to Guarantor's demand for reimbursement. Each Guarantor agrees to be liable even if we do one or more of the following: (1) give the Buyer more time to pay one or more payments; (2) give a full or partial release to any other Guarantor; (3) release any security; (4) accept less from the Buyer than the total amount owing; or (5) otherwise reach a settlement relating to this contract or extend the contract. Each Guarantor acknowledges receipt of a completed copy of this contract and guaranty at the time of signing.

Guarantor waives notice of acceptance of this Guaranty, notice of the Buyer's non-payment, non-performance, and default; and notices of the amount owing at any time, and of any demands upon the Buyer.

Guarantor X _____ Date _____ Guarantor X _____ Date _____

Address _____

Seller Signs GREENWOOD CHEVROLET BUICK GMC Date 03/21/16 By _____ Title J/T/16

AW FORM NO. 553-CA-ARB (REV. 7/13) U.S. PATENT NO. 9450,752 ©2013 The Reynolds and Reynolds Company TO ORDER: www.rey.com; 1-800-344-0936; fax 1-800-931-3955 THE PRINTER MAKES NO WARRANTY, EXPRESS OR IMPLIED, AS TO CONTENT OR FITNESS FOR PURPOSE OF THIS FORM. CONSULT YOUR OWN LEGAL COUNSEL.

DEALER COPY

repayment. If you pay off all your debt early, you may be charged a minimum finance charge. Security Interest: You are giving a security interest in the vehicle being purchased. Additional information: See this contract for more information including information about nonpayment, default, any required payment in full before the scheduled date, minimum finance charges, and security interest.

ITEMIZATION OF THE AMOUNT FINANCED (Seller may keep part of the amounts paid to others.)

Table with columns for item description and amount. Total Cash Price: 42260.00. Items include Cash Price of Motor Vehicle and Accessories (41710.00), Document Processing Charge (80.00), Emissions Testing Charge (N/A), Theft Deterrent Device (N/A), Surface Protection Product (795.00), EV Charging Station (N/A), and Sales Tax (3666.46).

If any insurance is checked below, policies or certificates from the named insurance companies will describe the terms and conditions.

Application for Optional Credit Insurance

Credit Life: Buyer Co-Buyer Both

Credit Disability (Buyer Only)

Total Credit Insurance Premiums \$ N/A

Insurance Company Name N/A

Home Office Address N/A

Credit life insurance and credit disability insurance are not required to obtain credit. Your decision to buy or not buy credit life and credit disability insurance will not be a factor in the credit approval process. They will not be provided unless you sign and agree to pay the extra cost. Credit life insurance is based on your original payment schedule. This insurance may not pay all you owe on this contract if you make late payments. Credit disability insurance does not cover any increase in your payment or in the number of payments. Coverage for credit life insurance and credit disability insurance ends on the original due date for the last payment unless a different term for the insurance is shown above.



FOR DEPARTMENT USE ONLY

STOCK # [REDACTED]

CASHIER DATE LINE STAMP [REDACTED]

DATE FIRST SOLD AS A NEW VEHICLE (MM/DD/YYYY) 03/21/2016	DATE FIRST OPERATED (MM/DD/YYYY) 03/21/2016	NRM/IND
---	--	---------

MAKE GMC	YEAR MODEL 2015	BODY TYPE PK	MOTIVE POWER GAS	NUMBER OF AXLES 2	UNLADEN WEIGHT 5317
-------------	--------------------	-----------------	---------------------	----------------------	------------------------

VEHICLE IDENTIFICATION NUMBER 1GTV2UEC3FZ [REDACTED]	M/C ENGINE NUMBER OR ADDITIONAL IDENTIFICATION NUMBER	OHV/MOTORCYCLE DEALERS ONLY <input type="checkbox"/> On-Highway <input type="checkbox"/> Off-Highway
---	---	---

FOR CAMP TRAILERS AND TRAILER COACHES	LENGTH IN INCHES	WIDTH IN INCHES	GVWR (PICKUPS ONLY)	STATE	ZIP CODE
---------------------------------------	------------------	-----------------	---------------------	-------	----------

SOLD TO: PRINT TRUE FULL NAME AS IT APPEARS ON THE DRIVER LICENSE OR ID CARD IN THE ORDER SHOWN BELOW (1) [REDACTED]	EQUIPMENT NUMBER	DRIVER LICENSE/ID CARD NO. [REDACTED]
---	------------------	--

<input type="checkbox"/> AND (LAST)	FIRST	MIDDLE	SUFFIX	DRIVER LICENSE/ID CARD NO.
-------------------------------------	-------	--------	--------	----------------------------

BUSINESS OR RESIDENCE ADDRESS [REDACTED]	APT./STE. NO.	CITY [REDACTED]	STATE	ZIP CODE
---	---------------	--------------------	-------	----------

ABOVE (OR LOCATION IF TRAILER COACH)	APT./STE. NO.	CITY	STATE	ZIP CODE
--------------------------------------	---------------	------	-------	----------

LIENHOLDER OR LEGAL OWNER—PRINT TRUE FULL NAME (IF NONE, MUST PRINT "NONE" AND INITIAL) BK STOCKTON	ELECTRONIC LIENHOLDER ID. # ELT# 1.08
--	--

BUSINESS OR RESIDENCE ADDRESS PO BX 1110	APT./STE. NO.	CITY STOCKTON	STATE CA	ZIP CODE 95201
---	---------------	------------------	-------------	-------------------

LESSEE ADDRESS—REQUIRED WHEN DIFFERENT FROM REGISTERED OWNER ABOVE	APT./STE. NO.	CITY	STATE	ZIP CODE
--	---------------	------	-------	----------

If a passenger vehicle, will it be used for hire or to provide a service of transporting passengers in conjunction with a business?
 Yes No

APPLICANT'S CERTIFICATION: [REDACTED] perjury under the laws of the State of California that the foregoing is true and correct.
 DATE: 03/21/2016 BUYER: (1) [REDACTED] (2) X

CERTIFICATE OF COST—The dealer certifies under penalty of perjury under the laws of the State of California that the cost of the vehicle entered in the Certificate of Cost is correct. Equipment that is physically attached to the vehicle, plus any trade-in allowances (exclude state or local taxes, insurance and finance charges).

	DATE PURCHASED/ACQUIRED	COST
A — Cost of vehicle purchased as a: <input checked="" type="checkbox"/> Complete vehicle <input type="checkbox"/> Chassis only <input type="checkbox"/> Cab and chassis	03/21/2016	44030.00
B — Cost of trailer coach including all permanently attached items (wall to wall carpeting, factory air conditioning, built-in appliances, etc.).		

ODOMETER DISCLOSURE STATEMENT

Federal and state law requires that you state the mileage upon transfer of ownership. Failure to complete or making a false statement may result in fines and/or imprisonment. The odometer reading is [REDACTED] (no tenths) miles, and to the best of my knowledge reflects the ACTUAL mileage unless one of the following statements is checked.

WARNING — Is NOT the actual mileage. Mileage EXCEEDS the odometer mechanical limits.

I/we certify (or declare) under penalty of perjury under the laws of the State of California that the foregoing is true and correct.

DATE: 03/21/2016	HAND PRINTED SELLER'S FULL NAME/COMPANY AGENT: GREENWOOD CHEVROLET	DEALER'S NUMBER: 51491
DATE: 03/21/2016	HAND PRINTED BUYER'S FULL NAME/COMPANY AGENT: BUICK GMC	

— DMV copy —



NEW VEHICLE DEALER NOTICE

After completion, detach this stub copy and mail direct to Department of Motor Vehicles, P.O. Box 944292, Sacramento, CA 94244-2920, no later than the period of time specified in Section 5901 VC.

MAKE GMC	BODY TYPE PK	VEHICLE IDENTIFICATION NUMBER 1GTV2UEC3FZ [REDACTED]
-------------	-----------------	---

DATE FIRST SOLD AS A NEW VEHICLE (MM/DD/YYYY) 03/21/2016	DEALER'S NUMBER [REDACTED]	SALESPERSON'S NUMBER S916676
---	-------------------------------	---------------------------------

SOLD TO: PRINT TRUE FULL NAME(S)
[REDACTED]

ADDRESS
[REDACTED]

NOTE: UPON TRANSFER OR SALE, DEALER MUST ENTER ODOMETER READING HERE: [REDACTED] **IMPORTANT!** ENTER BOTH DEALER'S AND SALESPERSON'S NUMBERS. This is a notice of purchase of vehicle. Do not use as an application for registration or title.



VEHICLE/VESSEL TRANSFER AND REASSIGNMENT FORM

INSTRUCTIONS ON REVERSE SIDE — ALL SIGNATURES MUST BE IN INK — PHOTOCOPIES NOT ACCEPTED

This form is not the ownership certificate. It must accompany the titling document or Application for Duplicate Title. For Car Buyer's Bill of Rights, visit www.dmv.ca.gov.

ACQUISITION NUMBER (DISMANTLER ONLY)

SECTION 1 — VEHICLE/VESSEL DESCRIPTION

Table with 5 columns: IDENTIFICATION NUMBER, YEAR MODEL, MAKE, LICENSE PLATE/CF NO., MOTORCYCLE ENGINE NUMBER. Row 1: 1GTV2UEC3FZ, 2015 SIERRA 1500, GMC, [REDACTED]

SECTION 2 — BILL OF SALE

I/We GREENWOOD CHEVROLET BUICK GMC sell, transfer, and deliver the above vehicle/vessel

to [REDACTED] on 03/21/16 for the amount of \$ [REDACTED]

If this was a gift, indicate relationship: (e.g., parents, spouse, friend, etc.) \$ N/A

SECTION 3 — ODOMETER DISCLOSURE STATEMENT (Void if Mileage is Altered or Erased)

Federal and State Law requires that you state the mileage upon transfer of ownership. Failure to complete or providing a false statement may result in fines and/or imprisonment.

The odometer now reads [REDACTED] 30 (no tenths) miles, and to the best of my knowledge reflects the ACTUAL mileage unless one of the following statements is checked.

WARNING—ODOMETER DISCREPANCY

- Odometer reading is NOT the actual mileage
Mileage EXCEEDS the odometer mechanical limits

Explain odometer discrepancy:

SECTION 4 — BUYER AND SELLER (MUST hand print his or her name, date and sign this section.)

BUYER'S SECTION

I acknowledge the odometer reading and the facts of the transfer. I certify (or declare) under penalty of perjury under the laws of the State of California that the foregoing is true and correct.

Table for Buyer's Section with columns: SIGNATURE, DATE, DL/D OR DEALER/DISM #. Includes fields for name, address, city, state, zip code, and telephone number.

SELLER'S SECTION

I certify (or declare) under penalty of perjury under the laws of the State of California that the foregoing is true and correct.

Table for Seller's Section with columns: SIGNATURE, DATE, DL/D OR DEALER/DISM #. Includes fields for name (EUGENE ANDRASE), address (270 SAN FELIPE ROAD), city (HOLLISTER), state (CA), zip code (95023), and telephone number ((831)637-5328).

SECTION 5 — POWER OF ATTORNEY

I/We [REDACTED] appoint GREENWOOD CHEVROLET BUICK GMC as my attorney in fact to complete all necessary documents, as needed, to transfer ownership as required by law.

Table for Power of Attorney with columns: SIGNATURE, DATE. Includes fields for name and date (03/21/2016).

PE18-012

GM

3-27-2019

Q3

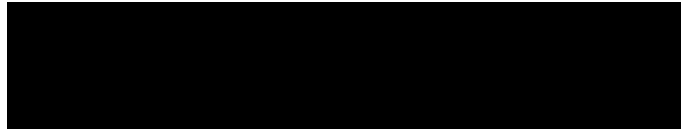



CALIFORNIA

3395 East La Palma Ave
Anaheim, CA 92807

P: 949.777.6032
F: 714.844.9035

June 30, 2018

VIA EMAIL

RE: [REDACTED] vs *General Motors LLC*
Los Angeles County Superior Court
Case No: [REDACTED]
Vehicle: 2016 Chevrolet Suburban
VIN#: 1GNSCHKC3GR [REDACTED]
GM Legal File No: [REDACTED]

Dear Mr. Farias:

Please be advised that the above-referenced matter has settled for a total of \$70,521.04, including attorneys' fees and costs. At your earliest convenience, please forward General Motors' settlement draft as follows:

1. A check in the amount of \$30,110.69 made payable to [REDACTED] and California Lemon Law Center". This check will be used to reimburse plaintiff's down payment, monthly payments and plaintiff's attorney's fees and costs. California Lemon Law Center's Federal Tax Identification Number [REDACTED]
2. A check in the amount of \$40,410.35 made payable to "Ally Financial". This check will be used to pay off Plaintiff's loan to obtain clear title. The account number is 061-9239-



erskinelaw.com • MICHIGAN • CALIFORNIA • OHIO

82693 the payoff is good through May 25, 2018. Please forward the check to Ally Financial at 6716 Grade Lane Bldg 9, Suite 910 Louisville, KY 40213. Attention: Payment Processing.

Concurrent with ordering this check, we are forwarding a Settlement Agreement and Request for dismissal to plaintiffs' counsel. The settlement draft will be retained until such time as we are in receipt of the signed closing documents. Should you have any questions, please do not hesitate to contact me.

Very truly yours,

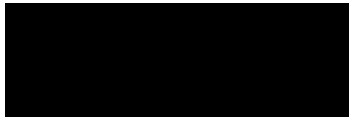

Mary Lynn Arens

Enclosures:

1. Check Approval Form
2. Signed Release Agreement
3. Settlement Confirmation Letter
4. Repurchase Worksheet
5. Payoff
6. Registration
7. Purchase Contract
8. Warranty History
9. Invoice (BARS)
10. Supporting Repair Orders



ENCLOSURE 1



Case Number: [REDACTED]
Originator Name: Daena Gutierrez 949-777-6032 dgutierrez@erskinelaw.com
Created Date: 06/30/2018

Vehicle Info

***VIN:** 1GNSCHKC3GR [REDACTED] **MSRP:** 57915.0 ***TAC #:** NA
Year: 2016 **Make:** Chevrolet **Model:** Suburban
Vehicle Comments & TAC Explanation:

Original Purchase Date: 12/10/2015 *** Repurchase Mileage:** 34000
*** Original Purchase Condition:** New

Vehicle Owner(s)

Entity Type: Person
*** Names(s) on Title:** [REDACTED] *** Title State:** CA
*** Primary Owner:** [REDACTED]
*** Address:** [REDACTED]
*** City:** [REDACTED] *** State:** [REDACTED] *** ZIP Code:** [REDACTED]
*** Day Phone:** [REDACTED] *** Home Phone:** [REDACTED] *** Cell Phone:** [REDACTED]
*** E-mail:** [REDACTED] *** Fax Phone:** [REDACTED]

*** Reason Repurchase** Engine mount broken.

UCC Codes (J1201) Engine - Motor and Engine Mounts - Cracked

Repurchasing Dealer:

*** Dealer #:** [REDACTED] **Dealer Name:** CAMINO REAL CHEVROLET
Region: 10 **District:** 1114
*** Phone:** (323) 264-3050 **Fax:** (323) 264-9750
*** Contact Name:** Mo Gutierrez *** Contact Title:** Service Manager **E-Mail:**

Repair

*** Contact Name:** *** Contact Title:**

Vehicle Location: -

Customer's Attorney

Legal Case Ref. #: [REDACTED] **Contact:** Aram Aslanian
Firm Name: California Lemon Law Cen.. **State:** CA **Zip Code:** 91202
Address: 535 Glenoaks Blvd **Fax:** **E-mail:**
City: Glendale
Phone: (818) 547-5777

Local Counsel

Firm Name: 163909 - Erskine Law Gro.. **Contact Person:** Erskine Law Group
Address: 3995 E. La Palma Ave.
City: Anaheim **State:** CA **Zip Code:** 92807
Phone: 949-777-6032 **Fax:** 949-916-1152 **E-mail:**



Case Number: [REDACTED]
Originator Name: Daena Gutierrez 949-777-6032 dgutierrez@erskinelaw.com
Created Date: 06/30/2018

Vehicle Lien Holder

Type of Secured Interest: Standard Lien	* Company: Ally Financial	Account #: [REDACTED]
Payoff Amount: 40410.35	Per Diem: 0.0	Payoff Date: 2018-05-25
Contact or Attention: Payment Processing	Address: 6716 Grade Lane Bldg 9, ..	
City: Louisville	State: KY	ZIP Code: 40213
Day Phone: (888) 925-2559	Fax:	E-mail:

Transaction Details

Siebel Request #: [REDACTED]	* Disposition: Auction	Trans. State: CA
* Trans. Type: Straight	Trans. Source: Lcl Counsel - Lawsuit - Vol or Mediated	
Compliance Type:	Compliance Date:	
* Closing Date: 2018-07-06	Money to Dealer: 0.0	Money to Manuf.: 0.0

Repurchase Vehicle

Replacement VIN:

Disposition:

*** Processing Instructions:** Send repurchase check direct to local counsel at Erskine Law Group, send surrender documents straight to dealership. If you have any questions contact Bettina Dugan at bdugan@erskinelaw.com.

Disbursement(s)

Payment Type	TIN	Payee	Payee Line 2	Amount
Joint Customer/Attorney Repurchase Lien Payoff	[REDACTED]	[REDACTED]	California Lemon Law Center	30110.69 40410.35

ENCLOSURE 2

SETTLEMENT AGREEMENT AND RELEASE OF ALL CLAIMS

This Settlement Agreement and Release of All Claims (hereinafter the "Agreement") is made and effective as of 6-4-18, 2018 by, between, and among [REDACTED] as plaintiff ("plaintiff") and GENERAL MOTORS as defendant ("defendant"). Hereinafter, plaintiff and defendant may be referred to collectively as the "parties" or individually as a "party." This Agreement is made and entered into with reference to the following facts:

a. On or about December 10, 2015 plaintiff purchased a 2016 Chevrolet Suburban, VIN 1GNSCHKC3GR [REDACTED] (hereinafter "the subject vehicle"). Plaintiff has alleged various malfunctions of the subject vehicle including defects in materials and workmanship.

b. There is pending in the Superior Court of the State of California, for the County of Los Angeles, Case No. [REDACTED] initiated by the plaintiff against defendant (the "lawsuit").

c. The parties enter into this Agreement to settle all disputes, claims and actions arising out of or relating to the purchase, sale, lease, repair, manufacture, maintenance and/or other damage or matter relating to the subject vehicle, and/or any other actions, conduct, omissions, or events alleged in the lawsuit.

d. Without admitting any liability or wrongdoing whatsoever, the parties wish to settle and compromise all claims, disagreements and disputes arising out of the above facts and the allegations in the lawsuit.

NOW, THEREFORE, in consideration of the mutual promises contained herein, and for other good and valuable consideration, the receipt of which is hereby acknowledged, the parties agree as follows:

1. Recitals

The recitals set forth in paragraphs a through d above are incorporated into this Agreement by reference.

2. Closing

A closing of this Agreement shall occur as soon as practicable at which time all documents and items to be exchanged to effectuate the purposes of this Agreement, including payment of settlement proceeds to the plaintiff and return of the subject vehicle to General Motors LLC, shall be tendered. Closing shall take place at a mutually convenient place and time to be arranged by counsel for General Motors LLC as soon as counsel for defendant receives notice that all documents and items necessary to effectuate the purposes of this

Agreement have been executed and are ready to be exchanged. Defendant shall use their best efforts to effectuate the closing within 30 days after this Agreement is fully executed. Defendant shall not be held liable for acts beyond the defendants' control which cause delay in exchanging the settlement proceeds and effectuating the closing. Documents and items necessary to close this Agreement include, but are not limited to, the following:

a. From the Plaintiff:

- (i) The subject vehicle in salable condition and with unexpired registration or valid Certification of Planned Non-operation, as defined in paragraph 4a herein;
- (ii) The clear certificate of title to the subject vehicle or such other documentation as provided in paragraph 4b; and
- (iii) A request for dismissal with prejudice of the entire lawsuit as against all defendants executed by counsel for plaintiff.

b. From Defendant, General Motors LLC:

- (i) A check in the amount of Thirty Thousand One Hundred Ten Dollars and 69/100 Cents (\$30,110.69) made payable to plaintiff and their attorney. The amount of \$30,110.69, is inclusive of \$10,000.00 in attorney's fees and cost.
- (ii) A second check in the amount of Forty Thousand Four Hundred Ten Dollars and 35/100 Cents (\$40,410.35) made payable to lender.

Before closing each party shall execute and deliver this Agreement (or a counterpart of this Agreement as provided in paragraph 9 herein) to counsel for General Motors LLC.

3. Consideration to Plaintiff

In consideration for plaintiff's agreement herein, General Motors LLC agrees to deliver to plaintiff, at closing, the following consideration:

a. Defendants' delivery of settlement check

Defendant shall deliver to plaintiffs' attorney, at closing, a check in the amount of Thirty Thousand One Hundred Ten Dollars and 69/100 Cents (\$30,110.69).

4. Consideration to Defendant

In consideration for defendants' agreement herein, plaintiff shall release all defendants from all claims as provided in paragraph 5 herein and shall deliver to General Motors LLC at or before closing the following:

a. Plaintiff's surrender of the subject vehicle in salable condition

Plaintiff shall surrender the subject vehicle to General Motors LLC at closing. The surrender shall occur at a mutually agreeable location.

Plaintiff shall surrender the subject vehicle currently registered except as follows. If the subject vehicle's registration has expired, plaintiff may surrender the vehicle with a DMV Certificate of Planned Non-Operation. This Certificate shall have been executed before the vehicle's last registration expired. It shall cover the period from registration expiration to surrender.

Plaintiff shall deliver to General Motors LLC, at closing, the subject vehicle in salable condition. At closing, the subject vehicle will be inspected by the defendants to determine whether it is in salable condition. As used herein, "in salable condition" means the vehicle is clean, in good working order with all originally invoiced options and accessories intact, and free from any existing collision damage, or other non-conformities, but does not include normal wear and tear or such non-conformities as are alleged to exist in the lawsuit. In the event the inspection of the subject vehicle reveals that it is not in acceptable condition, plaintiffs shall pay to General Motors LLC prior to closing the reasonable costs of repair as necessary to make the vehicle in salable condition. All payments by plaintiff to General Motors LLC due under this paragraph shall be delivered at or before closing.

b. Plaintiff's delivery of title to the subject vehicle to defendant

Plaintiff shall deliver the certificate of title to the subject vehicle free and clear of all liens and encumbrances to General Motors LLC at or before closing. In the event the subject vehicle serves as collateral for an existing loan to plaintiff, plaintiff shall, prior to closing, execute all documents necessary to allow defendant to take possession of the clear certificate of title to the subject vehicle at closing.

c. Plaintiff's dismissal of all claims against defendant

Plaintiff shall file a Request for Dismissal with prejudice of the entire lawsuit as against all defendants forthwith upon receipt of the checks referred to above and confirmation that their loan balance with Financial Partners Credit Union has been paid in full.

5. Plaintiff's Full Release of All Claims Against Defendant

As additional consideration paid to defendant for entering into this Agreement, plaintiff does hereby fully and forever remise, release and discharge defendant, as well as their predecessors, successors, parent corporations, subsidiaries, affiliates, dealers, directors, officers, partners, heirs, executors, administrators, attorneys, agents, employees and assigns, and each of them, from any and all claims, demands, rights and causes of action of whatsoever kind and nature, whether known or unknown, accrued and not yet accrued, that plaintiff may now have, or may ever obtain, arising out of or in any way related to plaintiffs' purchase, sale, lease, repair, operation, maintenance and/or other damage or matter relating to the subject vehicle, and/or the actions, conduct or omissions, or events alleged in the lawsuit.

6. Disclaimer of Liability

It is understood and agreed that this Agreement and settlement is a compromise of doubtful and disputed claims, and that neither the payment of the sums specified above, nor the negotiation of this Agreement shall be considered an admission of liability whatsoever by any party to this Agreement. It is understood that the defendant has denied, and presently denies, the allegations of the lawsuit and that no past or present wrongdoing on the part of the defendant shall be implied from any payments, negotiations, or entry into this Agreement.

8. Representation of Comprehension of Document

In entering into this Agreement, each of the parties hereto represents that they have read the contents of this Agreement, that the terms contained herein have been fully explained to them by their attorneys, and that those terms are fully understood and voluntarily accepted by them, that they have relied upon legal advice of their respective attorneys, who are the attorneys of their own choosing, and hereafter no such party shall deny the validity of this Agreement on the ground that it did not have advice of counsel.

9. Miscellaneous Provisions

a. This Agreement shall be binding upon, and inure to the benefit of, the executors, administrators, heirs, assigns and successors of each party hereto.

b. Each party to this Agreement warrants and represents that they are fully and properly authorized to enter into this Agreement and that all necessary corporate, administrative, or governmental approvals have been obtained prior to execution of this Agreement.

c. The parties shall promptly execute any and all further or additional instruments and will perform any acts which may become necessary in order to effectuate and carry out the purposes of this Agreement.

d. Neither any failure nor any delay on the part of any party in exercising any right hereunder shall operate as a waiver thereof, nor shall any single or partial exercise of any right hereunder preclude any other or further exercise thereof or the exercise of any right.

e. This Agreement constitutes the entire agreement of compromise and settlement between the parties. This Agreement shall not be altered or amended except by a writing signed by the party or parties to be charged with such alteration or amendment.

f. This Agreement is being executed and delivered, and is intended to be performed, in the State of California, and to the extent permitted by law, the execution, validity, construction and performance of this Agreement shall be construed and enforced in accordance with the laws of this State. This Agreement shall be deemed made and entered in Riverside County.

g. This Agreement shall not be construed against any party on the basis that party's attorney drafted this Agreement.

IN WITNESS THEREOF, each of the undersigned has executed this Settlement Agreement and Release of All Claims.

Dated: 6-4-18

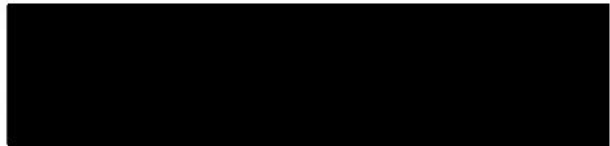

APPROVED AS TO FORM AND CONTENT:

Dated: 6/4/18

By:

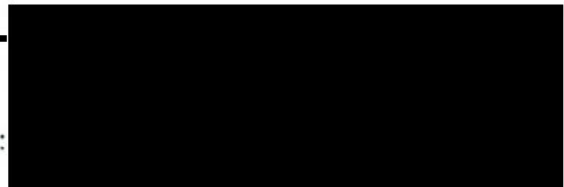

Attorney for Plaintiffs

ENCLOSURE 3



CALIFORNIA

3395 East La Palma Ave
Anaheim, CA 92807

P: 949.777.6032
F: 714.844.9035

June 30, 2018

VIA EMAIL

California Lemon Law Center
535 W. Glenoaks Blvd
Glendale, CA 91202

RE: [REDACTED] vs *General Motors LLC*
Los Angeles County Superior Court
Case No: [REDACTED]
Vehicle: 2016 Chevrolet Suburban
VIN#: 1GNSCHKC3GR[REDACTED]
GM Legal File No: [REDACTED]

Dear California Lemon Law Center:

This letter shall confirm the settlement of this matter, which was agreed to on June 4, 2018 with defendants. The settlement includes a full refund to plaintiff of all sales tax and consists of the following payments by defendants, in exchange for the return of the subject vehicle free and clear of all liens and encumbrances and the dismissal of the entire action, with prejudice:

Total Paid:	\$69,278.04
Includes Sales Tax: \$0.00	
Mileage Offset:	[\$8,757.00]



erskinelaw.com • MICHIGAN • CALIFORNIA • OHIO

Additional Settlement Payment:	\$0.00
Attorneys' Fees /Costs:	<u>\$10,000.00</u>
	\$70,521.04

Defendants have already begun processing the settlement checks and I expect to receive them in our offices shortly. All the documents necessary to conclude the settlement of this matter have already been forwarded to you. Please sign and fax this page back to our offices so that we may complete the check processing.



Mary Lynn Arens

California Lemon Law Center
Attorney for Plaintiff



ENCLOSURE 4

STRAIGHT-PAYMENT-LEASE REPURCHASE WORKSHEET - BRC COMMON

File Number
[REDACTED]

Customer Name
[REDACTED]

Worksheet Filled Out By
Bettina Dugan

Draft-Add question marks beside category (not in dollar fields) to indicate incomplete information

Vehicle VIN
1GNSCHKC3GR [REDACTED]

Date
Friday, June 29, 2018

USAGE FORMULAS		STRAIGHT REPURCHASE - BASE		PAYMENT (CA, FL & WV) OR LEASE REPURCHASE	
1	To calculate usage:	1	Base Price \$0.00	1	Down Pmt / Cap Cost Reduction \$0.00
2	Use ONLY one of the 4 methods in this column or	2	Conversion / Upfit cost \$0.00	2	Pmts (includes 1st month if lease) \$28,867.73
3	follow applicable lemon law formula for your state	3	Reg./Lic./Title Fees \$0.00	3	Reg./Lic./Title Fees (leases only) \$0.00
4		4	State Fees \$0.00	4	Tax (leases only) \$0.00
5	A. USAGE USING L.L. FORMULA	5	Aftermarket Items \$0.00	5	Aftermarket Items \$0.00
6	Base Price/Total Repurch Price \$0.00	6	Sales Tax \$0.00	6	Other-Additional Settlement \$0.00
7	Mileage 0	7	Finance Charges \$0.00	7	Other-Explain \$0.00
8	Denominator 100,000	8	GMPP (* only for WI) \$0.00	8	Other-Explain \$0.00
9	Usage \$0.00	9	Other-Explain \$0.00	9	Other-Explain \$0.00
10		10	Total Purchase Price \$0.00	10	Total Additions \$28,867.73
11	B. USAGE - NEGOTIATED \$0.00	11		11	
12		12	* Usage/Depreciation \$0.00	12	* Usage/Depreciation \$8,757.04
13		13	Damage \$0.00	13	Damage \$0.00
14	C. USAGE USING CENTS/MILE	14	Late charges \$0.00	14	Unpaid Interest \$0.00
15	Mileage 0	15	Over-Allowance \$0.00	15	Over-Allowance \$0.00
16	Cents per mile \$0.000	16	Negative Equity \$0.00	16	Negative Equity \$0.00
17	Usage \$0.00	17	Incentives \$0.00	17	Incentives \$0.00
18		18	Other-Explain \$0.00	18	Sec. Dep. (leases) if reimbursing above \$0.00
19		19	Other-Explain \$0.00	19	Extended Service Contract \$0.00
20	D. USAGE-CALIFORNIA ONLY	20	Other-Explain \$0.00	20	Gap Insurance \$0.00
21	Base price section-Used when NOT financed.	21	Other-Explain \$0.00	21	Over Mileage Penalty \$0.00
22	"Actual Price Paid" (Base) \$0.00	22	Total Deductions \$0.00	22	Total Deductions \$8,757.04
23	Mileage 0	23		23	
24	Usage \$0.00	24	Repurchase Subtotal \$0.00	24	Total Refund to Customer \$20,110.69
25	OR	25	Loan Payoff good thru xx/xx/xx \$0.00	25	Dir Buyout (lease) or Loan Payoff \$40,410.35
26	Payment/Lease-Used when financed.	26	Total Refund to Customer \$0.00	26	(GMAC=DL quote) good thru 3/6/2018 \$10,000.00
27	"Actual Price Paid" (Pmt/Lease) \$69,278.04	27	Attorney's Fees \$0.00	27	Attorney's Fees \$10,000.00
28	Mileage 0	28	Total Repurchase \$0.00	28	Total Repurchase \$70,521.04
29	Any ext service contract (CA only) 0	29	Edmunds (Legal Only) \$0.00	29	Edmunds (Legal Only) \$0.00
30	Usage \$0.00	30	Estimated Auction Value \$0.00	30	Estimated Auction Value \$0.00
31		31	Projected Loss \$0.00	31	Projected Loss \$70,521.04

PURCHASE PRICE (before t/t)	\$ -	TRADE ALLOWANCE	\$ -	PURCHASE PRICE	\$ -
MSRP (FROM BARS INVOICE)	\$ -	PAYOFF OF TRADE	\$ -	INCENTIVE* (from BARS)	\$ -
DIFFERENCE	\$ -	DIFFERENCE	\$ -	OVERALLOWANCE	\$ -
if positive look for over allowance		if negative=negative equity		ACTUAL PRICE	\$ -
		TRADE ALLOWANCE	\$ -		
		ACV OF TRADE	\$ -	Do not include fuel fill credit	
Authorized Signature	Date	DIFFERENCE	\$ -	Include GM card points	
		ACV=actual cash value			

ENCLOSURE 5



Vehicle Payments | Request a Payoff Quote

Make a
Payment

Your payoff estimate as of May 18, 2018 is:

\$40,156.71

Transactions

If you're scheduling a payoff date after today, you'll need to include an additional \$7.46 finance charge for each day after May 25, 2018.

Enroll In Auto
Pay

Payment
Accounts

Request a
Payoff Quote

©2009-2018 Ally Financial Inc.



Vehicle Payments | Transactions

Make a
Payment

Transactions

Enroll In Auto
Pay

Payment
Accounts

Request a
Payoff Quote

Most Recent Transaction

▼ 2018		
May 9, 2018	Online Payment	Completed \$1,050.00
Apr 9, 2018	Online Payment	Completed \$1,000.00
Mar 8, 2018	Online Payment	Completed \$1,100.00
Feb 9, 2018	Online Payment	Completed \$1,000.00
Jan 10, 2018	Online Payment	Completed \$700.00
▼ 2017		
Dec 9, 2017	Online Payment	Completed \$1,100.00
Nov 9, 2017	Pay by Phone	Completed \$295.57
Nov 8, 2017	Online Payment	Completed \$1,000.00
Oct 9, 2017	Online Payment	Completed \$1,050.00
Sep 6, 2017	Online Payment	Completed \$1,000.00
Aug 6, 2017	Online Payment	Completed \$1,000.00

Jul 6, 2017 Online Payment	Completed \$1,000.00
Jun 7, 2017 Online Payment	Completed \$1,000.00
May 4, 2017 Online Payment	Completed \$1,100.00
Apr 6, 2017 Pay by Phone	Completed \$1,258.62
Mar 9, 2017 Online Payment	Completed \$1,015.25
Feb 2, 2017 Online Payment	Completed \$961.00
Jan 7, 2017 Online Payment	Completed \$1,000.00
▼ 2016	
Nov 25, 2016 Online Payment	Completed \$1,000.00
Oct 20, 2016 Online Payment	Completed \$1,100.00
Sep 9, 2016 Online Payment	Completed \$945.75
Aug 10, 2016 Online Payment	Completed \$1,000.00
Jul 7, 2016 Online Payment	Completed \$1,100.00
Jun 8, 2016 Online Payment	Completed \$991.50
May 4, 2016 Online Payment	Completed \$800.00
Apr 5, 2016 Online Payment	Completed \$1,000.00

Mar 3, 2016	Online Payment	Completed \$1,100.00
Feb 11, 2016	Online Payment	Completed \$1,100.00
Jan 14, 2016	Online Payment	Completed \$1,100.00
Jan 13, 2016	Online Payment	Returned \$1,100.00
Jan 9, 2016	Online Reversal	Completed \$-1,100.00
Jan 9, 2016	Original Online Payment Reversal	Completed \$1,100.00
Less Transactions ^		

ENCLOSURE 6



A Public Service Agency

TO OBTAIN A TITLE OR REGISTRATION CARD, MAIL THE ATTACHED DOCUMENTS AND REQUESTED ITEMS TO: DMV, PO BOX 942869, SACRAMENTO, CA 94269-0001. PENALTIES ARE DUE IF RENEWAL FEES ARE PAID AFTER THE EXPIRATION DATE. PLANNED NON-OPERATION (PNO) REQUESTS MUST BE SUBMITTED WITHIN 90 DAYS OF THE EXPIRATION DATE (ON OR BEFORE THE EXPIRATION DATE FOR OFF-HIGHWAY VEHICLES) OR ALL FEES AND PENALTIES ARE DUE. FOR A DMV OFFICE APPOINTMENT, GO ONLINE AT WWW.DMV.CA.GOV OR CALL 1-800 777-0133.

POSTING FEES ONLY

* * *



REPORT OF DEPOSIT OF FEES PAGE 1 OF 1



* INCOMPLETE APPLICATION**SEE ABOVE**THIS IS NOT AN OPERATING PERMIT *

MAKE	YR MODEL	YR 1ST SOLD	VLF CLASS	TYPE VEH	TYPE LIC	LICENSE NUMBER
CHEV	2016	2015	PL	11S	00	[REDACTED]
BODY TYPE MODEL	MP	MO				VEHICLE/VESSEL ID NUMBER
LL	G	WZ				1GNSCHKC3GR [REDACTED]
TYPE VEHICLE/VESSEL USE	DATE ISSUED	CC/ALCO	DT FEE RECVD	PIC		
AUTOMOBILE	12/28/15	19	12/28/15	0		

RDF REASONS: U

AMOUNT PAID

\$ 454.00

AMOUNT DUE	AMOUNT RECVD
\$ 454.00	CASH :
	CHCK : 454.00
	CRDT :



L / O



ENCLOSURE 7

**RETAIL INSTALLMENT SALE CONTRACT – SIMPLE FINANCE CHARGE
(WITH ARBITRATION PROVISION)**

Dealer Number _____ Contract Number _____ R.O.S. Number _____ Stock Number _____

Buyer Name and Address (Including County and Zip Code)	Co-Buyer Name and Address (Including County and Zip Code)	Seller-Creditor (Name and Address)
	N/A	CAMINO REAL CHEVROLET 2401 S ATLANTIC BLVD MONTEREY PARK CA 91754 LOS ANGELES

You, the Buyer (and Co-Buyer, if any), may buy the vehicle below for cash or on credit. By signing this contract, you choose to buy the vehicle on credit under the agreements on the front and back of this contract. You agree to pay the Seller - Creditor (sometimes "we" or "us" in this contract) the Amount Financed and Finance Charge in U.S. funds according to the payment schedule below. We will figure your finance charge on a daily basis. The Truth-In-Lending Disclosures below are part of this contract.

New Used	Year	Make and Model	Odometer	Vehicle Identification Number	Primary Use For Which Purchased
NEW	2016	CHEVROLET TRU SUBURBAN	105	1GNSCHKC36G	<input type="checkbox"/> Personal, family or household unless otherwise indicated below. <input type="checkbox"/> business or commercial

FEDERAL TRUTH-IN-LENDING DISCLOSURES

ANNUAL PERCENTAGE RATE	FINANCE CHARGE	Amount Financed	Total of Payments	Total Sale Price
The cost of your credit as a yearly rate. 6.90 %	The dollar amount the credit will cost you. \$ 13380.45 (e)	The amount of credit provided to you or on your behalf. \$ 59717.55	The amount you will have paid after you have made all payments as scheduled. \$ 73098.00 (e)	The total cost of your purchase on credit, including your down payment of \$ 0.00 is \$ 73098.00 (e)

(e) means an estimate

YOUR PAYMENT SCHEDULE WILL BE:

Number of Payments:	Amount of Payments:	When Payments Are Due:
One Payment of		
N/A	N/A	N/A
One Payment of		
N/A	N/A	N/A
One Payment of		
N/A	N/A	N/A
71	1015.25	Monthly beginning 01/10/2016
N/A	N/A	N/A
One final payment	1015.25	DUE ON 12/10/2021

Late Charge. If payment is not received in full within 10 days after it is due, you will pay a late charge of 5% of the part of the payment that is late.
Prepayment. If you pay off all your debt early, you may be charged a minimum finance charge.
Security Interest. You are giving a security interest in the vehicle being purchased.
Additional Information: See this contract for more information including information about nonpayment, default, any required repayment in full before the scheduled date, minimum finance charges, and security interest.

ITEMIZATION OF THE AMOUNT FINANCED (Seller may keep part of the amounts paid to others.)

1. Total Cash Price	
A. Cash Price of Motor Vehicle and Accessories	\$ 54255.60(A)
1. Cash Price Vehicle	\$ 54104.80
2. Cash Price Accessories	\$ 150.80
3. Other (Nontaxable)	
Describe N/A	\$ N/A
Describe N/A	\$ N/A
B. Document Processing Charge (not a governmental fee)	\$ 80.00 (B)
C. Emissions Testing Charge (not a governmental fee)	\$ N/A (C)
D. (Optional) Theft Deterrent Device (to whom paid) N/A	\$ N/A (D)
E. (Optional) Theft Deterrent Device (to whom paid) N/A	\$ N/A (E)
F. (Optional) Theft Deterrent Device (to whom paid) N/A	\$ N/A (F)
G. (Optional) Surface Protection Product (to whom paid) N/A	\$ N/A (G)
H. (Optional) Surface Protection Product (to whom paid) N/A	\$ N/A (H)
I. EV Charging Station (to whom paid) N/A	\$ N/A (I)
J. Sales Tax (on taxable items in A through I)	\$ 4890.20 (J)
K. Electronic Vehicle Registration or Transfer Charge (not a governmental fee) (to whom paid) AVRS	\$ 29.00 (K)
L. (Optional) Service Contract (to whom paid) N/A	\$ N/A (L)

STATEMENT OF INSURANCE

NOTICE. No person is required as a condition of financing the purchase of a motor vehicle to purchase or negotiate any insurance through a particular insurance company, agent or broker. You are not required to buy any other insurance to obtain credit. Your decision to buy or not buy other insurance will not be a factor in the credit approval process.

Vehicle Insurance

	Term	Premium
\$ N/A Ded. Comp., Fire & Theft	N/A Mos.	\$ N/A
\$ N/A Ded. Collision	N/A Mos.	\$ N/A
Bodily Injury \$ N/A Limits	N/A Mos.	\$ N/A
Property Damage \$ N/A Limits	N/A Mos.	\$ N/A
Medical N/A	N/A Mos.	\$ N/A
N/A	N/A Mos.	\$ N/A
Total Vehicle Insurance Premiums		\$ N/A

UNLESS A CHARGE IS INCLUDED IN THIS AGREEMENT FOR PUBLIC LIABILITY OR PROPERTY DAMAGE INSURANCE, PAYMENT FOR SUCH COVERAGE IS NOT PROVIDED BY THIS AGREEMENT.

You may buy the physical damage insurance this contract requires (see back) from anyone you choose who is acceptable to us. You are not required to buy

Buyer _____
 Co-Buyer N/A _____
 Seller _____

If any insurance is checked below, policies or certificates from the named insurance companies will describe the terms and conditions.

Application for Optional Credit Insurance

Credit Life: Buyer Co-Buyer Both
 Credit Disability (Buyer Only)

	Term	Exp.	Premium
Credit Life	N/A Mos.	N/A	\$ N/A
Credit Disability	N/A Mos.	N/A	\$ N/A
Total Credit Insurance Premiums			\$ N/A (b)
Insurance Company Name	N/A		
Home Office Address	N/A		

Credit life insurance and credit disability insurance are not required to obtain credit. Your decision to buy or not buy credit life and credit disability insurance will not be a factor in the credit approval process. They will not be provided unless you sign and agree to pay the extra cost. Credit life insurance is based on your original payment schedule. This insurance may not pay all you owe on this contract if you make late payments. Credit disability insurance does not cover any increase in your payment or in the number of payments. Coverage for credit life insurance and credit disability insurance ends on the original due date for the last payment unless a different term for the insurance is shown above.

You are applying for the credit insurance marked above. Your signature below means that you agree that: (1) You are not eligible for insurance if you have reached your 65th birthday. (2) You are eligible for disability insurance only if you are working for wages

M. (Optional) Service Contract (to whom paid) N/A \$ N/A (M)
 N. (Optional) Service Contract (to whom paid) N/A \$ N/A (N)
 O. (Optional) Service Contract (to whom paid) N/A \$ N/A (O)
 P. (Optional) Service Contract (to whom paid) N/A \$ N/A (P)
 Q. Prior Credit or Lease Balance paid by Seller to N/A (e) \$ N/A (Q)
 (see downpayment and trade-in calculation)
 R. (Optional) Gap Contract (to whom paid) N/A \$ N/A (R)
 S. (Optional) Used Vehicle Contract Cancellation Option Agreement \$ N/A (S)
 T. Other (to whom paid) N/A
 For N/A \$ N/A (T)

Total Cash Price (A through T) \$ 59254.80 (1)

2. Amounts Paid to Public Officials

A. Vehicle License Fees ESTIMATED \$ 353.00 (A)
 B. Registration/Transfer/Titling Fees ESTIMATED \$ 101.00 (B)
 C. California Tire Fees \$ 8.75 (C)
 D. Other N/A \$ N/A (D)

Total Official Fees (A through D) \$ 462.75 (2)

3. Amount Paid to Insurance Companies

(Total premiums from Statement of Insurance column a + b) \$ N/A (3)

4. State Emissions Certification Fee or State Emissions Exemption Fee \$ N/A (4)

5. Subtotal (1 through 4) \$ 59717.55 (5)

6. Total Downpayment

A. Agreed Trade-In Value Yr N/A Make N/A \$ N/A (A)
 Model N/A Odom N/A
 VIN N/A
 B. Less Prior Credit or Lease Balance (e) \$ N/A (B)
 C. Net Trade-In (A less B) (indicate if a negative number) \$ N/A (C)
 D. Deferred Downpayment \$ N/A (D)
 E. Manufacturer's Rebate \$ N/A (E)
 F. Other N/A \$ N/A (F)
 G. Cash \$ N/A (G)

Total Downpayment (C through G) \$ 0.00 (6)

(If negative, enter zero on line 6 and enter the amount less than zero as a positive number on line 10 above)

7. Amount Financed (5 less 6) \$ 59717.55 (7)

or print 30 hours a week or more on the Effective Date. (3) Only the Primary Buyer is eligible for disability insurance. **DISABILITY INSURANCE MAY NOT COVER CONDITIONS FOR WHICH YOU HAVE SEEN A DOCTOR OR CHIROPRACTOR IN THE LAST 6 MONTHS** (Refer to "Total Disabilities Not Covered" in your policy for details).
 You want to buy the credit insurance.

X
 Date Buyer Signature Age
N/A XN/A N/A
 Date Co-Buyer Signature Age

OPTIONAL GAP CONTRACT A gap contract (debt cancellation contract) is not required to obtain credit and will not be provided unless you sign below and agree to pay the extra charge. If you choose to buy a gap contract, the charge is shown in item 1R of the Itemization of Amount Financed. See your gap contract for details on the terms and conditions it provides. It is a part of this contract.

Term N/A Mos. N/A
 Name of Gap Contract

I want to buy a gap contract.

Buyer Signs X

OPTIONAL SERVICE CONTRACT(S) You want to purchase the service contract(s) written with the following company(ies) for the term(s) shown below for the charge(s) shown in item 1L, 1M, 1N, 1O, and/or 1P.

1L Company N/A
 Term N/A Mos. or N/A Miles
 1M Company N/A
 Term N/A Mos. or N/A Miles
 1N Company N/A
 Term N/A Mos. or N/A Miles
 1O Company N/A
 Term N/A Mos. or N/A Miles
 1P Company N/A
 Term N/A Mos. or N/A Miles
 Buyer X

SELLER ASSISTED LOAN

BUYER MAY BE REQUIRED TO PLEDGE SECURITY FOR THE LOAN, AND WILL BE OBLIGATED FOR THE INSTALLMENT PAYMENTS ON BOTH THIS RETAIL INSTALLMENT SALE CONTRACT AND THE LOAN.

Proceeds of Loan From: N/A
 Amount \$ N/A Finance Charge \$ N/A
 Total \$ N/A Payable in N/A
 installments of \$ N/A \$ N/A
 from this Loan is shown in item 6D.

AUTO BROKER FEE DISCLOSURE

If this contract reflects the retail sale of a new motor vehicle, the sale is not subject to a fee received by an autobroker from us unless the following box is checked:

Name of autobroker receiving fee, if applicable:
N/A

HOW THIS CONTRACT CAN BE CHANGED. This contract contains the entire agreement between you and us relating to this contract. Any change to the contract must be in writing and we must sign it. No oral changes are

Buyer Signs X
 Co-Buyer Signs XN/A

SELLER'S RIGHT TO CANCEL If Buyer and Co-Buyer sign here, the provisions of the Seller's Right to Cancel section on the back giving the Seller the right to cancel if Seller is unable to assign this contract to a financial institution will apply.

X
 Buyer XN/A
 Co-Buyer

Agreement to Arbitrate: By signing below, you agree that, pursuant to the Arbitration Provision on the reverse side of this contract, you or we may elect to resolve any dispute by neutral, binding arbitration and not by a court action. See the Arbitration Provision for additional information concerning the agreement to arbitrate.

Buyer Signs X
 Co-Buyer Signs XN/A

OPTION: You pay no finance charge if the Amount Financed, item 7, is paid in full on or before N/A, Year N/A. SELLER'S INITIALS N/A

THE MINIMUM PUBLIC LIABILITY INSURANCE LIMITS PROVIDED IN LAW MUST BE MET BY EVERY PERSON WHO PURCHASES A VEHICLE. IF YOU ARE UNSURE WHETHER OR NOT YOUR CURRENT INSURANCE POLICY WILL COVER YOUR NEWLY ACQUIRED VEHICLE IN THE EVENT OF AN ACCIDENT, YOU SHOULD CONTACT YOUR INSURANCE AGENT.
WARNING:
 YOUR PRESENT POLICY MAY NOT COVER COLLISION DAMAGE OR MAY NOT PROVIDE FOR FULL REPLACEMENT COSTS FOR THE VEHICLE BEING PURCHASED. IF YOU DO NOT HAVE FULL COVERAGE, SUPPLEMENTAL COVERAGE FOR COLLISION DAMAGE MAY BE AVAILABLE TO YOU THROUGH YOUR INSURANCE AGENT OR THROUGH THE SELLING DEALER. HOWEVER, UNLESS OTHERWISE SPECIFIED THE COVERAGE YOU OBTAIN THROUGH THE DEALER PROTECTS ONLY THE DEALER, USUALLY UP TO THE AMOUNT OF

THE UNPAID BALANCE REMAINING AFTER THE VEHICLE HAS BEEN REPOSSESSED AND SOLD.
FOR ADVICE ON FULL COVERAGE THAT WILL PROTECT YOU IN THE EVENT OF LOSS OR DAMAGE TO YOUR VEHICLE, YOU SHOULD CONTACT YOUR INSURANCE AGENT.
THE BUYER SHALL SIGN TO ACKNOWLEDGE THAT HE/SHE UNDERSTANDS THESE PUBLIC LIABILITY TERMS AND CONDITIONS.

S/S X _____ X N/A _____

Trade-In Payoff Agreement: Seller relied on information from you and/or the lienholder or lessor of your trade-in vehicle to arrive at the payoff amount shown in item 6B of the Itemization of Amount Financed as the "Prior Credit or Lease Balance." You understand that the amount quoted is an estimate.

Seller agrees to pay the payoff amount shown in 6B to the lienholder or lessor of the trade-in vehicle, or its designee. If the actual payoff amount is more than the amount shown in 6B, you must pay the Seller the excess on demand. If the actual payoff amount is less than the amount shown in 6B, Seller will refund to you any overage Seller receives from your prior lienholder or lessor. Except as stated in the "NOTICE" on the back of this contract, any assignee of this contract will not be obligated to pay the Prior Credit or Lease Balance shown in 6B or any refund.

Buyer Signature X N/A _____ Co-Buyer Signature X N/A _____

Notice to buyer: (1) Do not sign this agreement before you read it or if it contains any blank spaces to be filled in. (2) You are entitled to a completely filled in copy of this agreement. (3) You can prepay the full amount due under this agreement at any time. (4) If you default in the performance of your obligations under this agreement, the vehicle may be repossessed and you may be subject to suit and liability for the unpaid indebtedness evidenced by this agreement.

If you have a complaint concerning this sale, you should try to resolve it with the seller. Complaints concerning unfair or deceptive practices or methods by the seller may be referred to the city attorney, the district attorney, or an investigator for the Department of Motor Vehicles, or any combination thereof.

After this contract is signed, the seller may not change the financing or payment terms unless you agree in writing to the change. You do not have to agree to any change, and it is an unfair or deceptive practice for the seller to make a unilateral change.

Buyer Signature X _____ Co-Buyer Signature X N/A _____

The Annual Percentage Rate may be negotiable with the Seller. The Seller may assign this contract and retain its right to receive a part of the Finance Charge.

THERE IS NO COOLING-OFF PERIOD UNLESS YOU OBTAIN A CONTRACT CANCELLATION OPTION
California law does not provide for a "cooling-off" or other cancellation period for vehicle sales. Therefore, you cannot later cancel this contract simply because you change your mind, decide the vehicle costs too much, or wish you had acquired a different vehicle. After you sign below, you may only cancel this contract with the agreement of the seller or for legal cause, such as fraud. However, California law does require a seller to offer a two-day contract cancellation option on used vehicles with a purchase price of less than forty thousand dollars (\$40,000), subject to certain statutory conditions. This contract cancellation option requirement does not apply to the sale of a recreational vehicle, a motorcycle, or an off-highway motor vehicle subject to identification under California law. See the vehicle contract cancellation option agreement for details.

YOU AGREE TO THE TERMS OF THIS CONTRACT. YOU CONFIRM THAT BEFORE YOU SIGNED THIS CONTRACT, WE GAVE IT TO YOU, AND YOU WERE FREE TO TAKE IT AND REVIEW IT. YOU ACKNOWLEDGE THAT YOU HAVE READ BOTH SIDES OF THIS CONTRACT, INCLUDING THE ARBITRATION PROVISION ON THE REVERSE SIDE, BEFORE SIGNING BELOW. YOU CONFIRM THAT YOU RECEIVED A COMPLETELY FILLED-IN COPY WHEN YOU SIGNED IT.

Buyer Signature X _____ Date 2/10/15 _____ Co-Buyer Signature X N/A _____ Date N/A _____

Co-Buyers and Other Owners — A co-buyer is a person who is responsible for paying the entire debt. An other owner is a person whose name is on the title to the vehicle but does not have to pay the debt. The other owner agrees to the security interest in the vehicle given to us in this contract.

Other Owner Signature X _____ Address _____

GUARANTY: To induce us to sell the vehicle to Buyer, each person who signs as a Guarantor individually guarantees the payment of this contract. If Buyer fails to pay any money owing on this contract, each Guarantor must pay it when asked. Each Guarantor will be liable for the total amount owing even if other persons also sign as Guarantor, and even if Buyer has a complete defense to Guarantor's demand for reimbursement. Each Guarantor agrees to be liable even if we do one or more of the following: (1) give the Buyer more time to pay one or more payments; (2) give a full or partial release to any other Guarantor; (3) release any security; (4) accept less from the Buyer than the total amount owing; or (5) otherwise reach a settlement relating to this contract or extend the contract. Each Guarantor acknowledges receipt of a completed copy of this contract.
Guarantor waives notice of acceptance of this Guaranty, notice of the Buyer's non-payment, non-performance, and default; and _____ of any demands upon the Buyer.

Guarantor X _____ Date _____ Guarantor X _____ Date _____
Address _____ Address _____

Seller Signs CAMINO REAL CHEVROLET _____ Date 2/10/15 _____ By X _____ Title _____

DEALER COPY

ENCLOSURE 8



Jeralyn Vara

March 16, 2018

[Logout](#)

Global Warranty Management: [Main](#) > [Interface With Customer](#) > [View Vehicle Summary](#)

**INTERFACE WITH
CUSTOMER**

View Vehicle Summary |

This screen allows IVH users to view the Summary of Vehicle Information, Field Actions, Service Information, Applicable Warranties, Transaction History, Service Contract(s) if applicable, Warranty Block, Branded Title information and OnStar and XM Radio information (if applicable).

For this vehicle:

- [View Vehicle Summary](#)
 - Service Contract
 - Branded Title
 - Warranty Block
- [View Vehicle Build](#)
- [View Vehicle Component Summary](#)
- [View Vehicle Transaction History Detail](#)
- [View Vehicle Delivery Information](#)

Vehicle Information

VIN: 1GNSCHKC3GR [REDACTED] Model: CC15906-2016 SUBURBAN 1500 2WD
 Service Contract: No Branded Title: No Warranty Block: No PDI Status: Yes
 Order Type: 60 - RETAIL - SOLD
 Field Actions: [0 Open](#)

REQUEST ANOTHER VIN

Required Field Actions

Open Field Action Details are highlighted

Type	Number	Original Nbr	Description	Release Date	Status
Product Safety Recall	[REDACTED]	[REDACTED]	Frontal Airbag And Pretensioner Non Deploy	09/08/2016	Closed

Branded Title

*The VIN information contained herein and information derived therefrom is the proprietary property of The Polk Company and is to be used only for the purpose of warranty verification and shall not be used for any other purpose whatsoever.

Vehicle has no current record of branded titles.

Warranty Block

Vehicle has no current record of warranty block.

Service Information

Type	Number	Description	Posted Date
EI	PIE0365		06/21/2016
EI	PIE0359	Vehicle Crank with No Start or Stalling with DTC P0011 and/or P00C6 Set	03/15/2016

OnStar and XM Satellite Radio Information

Refer to Help page for details. For OnStar contact 888.ON.STAR1 (888.667.8271) and for XM Radio contact 877.GET.XMST (877.438.9677 Canada) and in the USA:800-556-3600.

OnStar Equipped: Y	OnStar Status: Active
XM Equipped: Y	XM Status: Active
OnStar Vehicle Diagnostics: N	DMN Enabled: N
	XM Radio ID: A48WG382

Applicable Warranties

Valid warranties are highlighted

Valid	Description	Warranty Add Date	Start Date	Effective Odometer	End Date	End Odometer
	Bumper to Bumper Limited Warranty	02/15/2018	12/11/2015	4 MI	12/11/2018	36,004 MI

Powertrain Limited Warranty	02/15/2018	12/11/2015	4 MI	12/11/2020	60,004 MI
Special Coverage 17336	02/15/2018	12/11/2015	4 MI	12/11/2020	60,004 MI
Corrosion Limited Warranty	02/15/2018	12/11/2015	4 MI	12/11/2021	100,004 MI
Emission Limited Warranty	02/15/2018	12/11/2015	4 MI	12/11/2018	50,004 MI
Emission Select Component Ltd Wty	02/15/2018	12/11/2015	4 MI	12/11/2023	80,004 MI
Emission Select State Component Ltd Wty	02/15/2018	12/11/2015	4 MI	12/11/2022	70,004 MI
Chevrolet Scheduled Maintenance-2 visits	02/15/2018	12/11/2015	4 MI	12/11/2017	24,004 MI

Service Contract

Vehicle has no current record of service contracts.

Transact

[View Details](#)

Job Card Date	Transaction Type	Transaction Adjustment	Labour Operation	Odometer Reading
12/26/2017	ZREG----Regular Vehicle Transaction		4413100 - Heater Inlet Hose Replacement	26,031 MI
12/26/2017	ZREG----Regular Vehicle Transaction		8466430 - 4-5-6 Clutch Plate Replacement	26,031 MI
12/26/2017	ZREG----Regular Vehicle Transaction		4065910 - Lower Oil Pan Replacement	26,031 MI
12/26/2017	ZREG----Regular Vehicle Transaction		4067080 - Engine Mount Replacement - Left Side	26,031 MI
07/26/2017	ZREG----Regular Vehicle Transaction		4050272 - Exhaust System Alignment	22,426 MI
07/01/2017	ZREG----Regular Vehicle Transaction		4041510 - Battery Replacement	19,614 MI
07/01/2017	ZREG----Regular Vehicle Transaction	Add Credit	8466450 - 3-5-Reverse Clutch Plate Replacement	19,614 MI
07/01/2017	ZREG----Regular Vehicle Transaction	Full Debit - Reversal	8466450 - 3-5-Reverse Clutch Plate Replacement	19,614 MI
07/01/2017	ZREG----Regular Vehicle Transaction		8466450 - 3-5-Reverse Clutch Plate Replacement	19,614 MI
07/01/2017	ZREG----Regular Vehicle Transaction		0600642 - Roadside - Over Mileage	19,164 MI
07/01/2017	ZREG----Regular Vehicle Transaction		0600022 - ROADSIDE SERVICE (TOWING)	19,164 MI
06/27/2017	ZREG----Regular Vehicle Transaction		2480118 - Replace vacuum pump, vacuum pump to booster hose, vacuum brake booster, and brake master cylinder	19,529 MI
06/27/2017	ZFAT----Field Action Recall		9102276 - 16007 - N16-204817 - Reprogram Inflatable Restraint Sensing and Diagnostic Module Calibrations	19,529 MI
11/02/2015	ZPDI----Pre-Delivery Inspection		0590072 - Pre-Delivery Inspection - Base Time	1 MI

Global Warranty Management: [Site Map](#)

[Privacy Policy](#) | [Terms of Use](#)

© 2005 General Motors. All rights reserved.

ENCLOSURE 9

2016 SUBURBAN 2WD 1/2 TON LT

GENERAL MOTORS LLC

GBA BLACK

/V8G

H2U JET BLACK

RENAISSANCE CENTER

ORDER NO. [REDACTED] /SRE

STOCK NO.

DETROIT MI 48243-1114

VIN 1GN SCHK C3 GR [REDACTED]

VEHICLE INVOICE [REDACTED]

*****6669*****13*20310S

MODEL & FACTORY OPTIONS	MSRP	INV AMT	RETAIL - SOLD
CC15906 SUBURBAN 2WD 1/2 TON LT	54730.00	50898.90	INVOICE 10/26/15
ATV SEATS, SECOND ROW BUCKET	590.00	536.90	SHIPPED 10/26/15
C6A GVW RATING - 7,300 LBS	N/C	N/C	EXP I/T 11/10/15
L83 ENGINE, 5.3L V8 ECOTEC3	N/C	N/C	INT COM 11/10/15
MYC TRANSMISSION, 6 SPD AUTOMATIC	N/C	N/C	PRC EFF 10/26/15
RD4 WHEELS, 20" POLISHED ALUMINUM (REPLACES STANDARD WHEELS)	1400.00	1274.00	KEYS V1473 V1473 WFP-S MTH OPT-2
VV4 4G LTE WI-FI(R) HOTSPOT WITH LIMITED DATA TRIAL AND MORE. (SUBJECT TO TERMS SEE ONSTAR.COM)	0.00	0.00	BANK: GM FINANCI CHG-TO 20-310
YF5 50-STATE EMISSIONS	N/C	N/C	SHIP WT: 5459 HP: 45.7 GVWR: 7300 GAWR.FT: 3500 GAWR.RR: 4200 EMPLOY: 51996.41 SUPPLR: 54104.80 NTR: 1/2 DAN: SARA EMPINC: 3254.97 SUPINC: 1146.58

TOTAL MODEL & OPTIONS	56720.00	52709.80	ACT 237	52203.20
DESTINATION CHARGE	1195.00	1195.00	H/B 261	1701.60
DEALER IMR CONTRIBUTION		283.60	ADV 261	283.60
LMA GROUP CONTRIBUTION		567.20	EXP 65A	567.20

TOTAL	57915.00	54755.60	PAY 310	54755.60
MEMO: TOTAL LESS HOLDBACK AND APPROX WHOLESALE FINANCE CREDIT		52233.05		

 INVOICE DOES NOT REFLECT DEALER'S ULTIMATE COST BECAUSE OF MANUFACTURER
 REBATES, ALLOWANCES, INCENTIVES, HOLDBACK, FINANCE CREDIT AND RETURN TO
 DEALER OF ADVERTISING MONIES, ALL OF WHICH MAY APPLY TO VEHICLE.

CAMINO REAL CHEVROLET

ENCLOSURE 10

(818) 933-3000

Monday - Friday:
7:00 A.M. - 6:00 P.M.
Saturday:
7:00 A.M. - 5:00 P.M.

EPA #: CAL000386348
BAR #: ARD260656

WARNING - Motor vehicles contain chemicals known to the State of California to cause cancer and birth defects or other reproductive harm. These chemicals are contained in many vehicle components and replacement parts, vehicle fluids, and paints and materials used to maintain vehicles, including, but not limited to, fuel, oil, batteries, brakes, and wheel balancing weights. When you service, clean or maintain your car, you will be exposed to listed chemicals contained in used oil, waste and replacement fluids, fumes, grease, grime, touch-up paint, certain replacement parts, and particulates from component wear. When we service your car, we will return used components to you upon request. Used parts and components contain chemicals known to the State of California to cause cancer and birth defects or other reproductive harm.

To minimize your exposure when servicing, maintaining or cleaning your vehicle: 1) work in a well ventilated area; 2) do not smoke, drink or eat while working; 3) wash your hands when finished or when taking a break; and 4) follow all manufacturer instructions pertaining to proper use and maintenance of motor vehicles and vehicle components.

(Posted in accordance with Proposition 65 in Cal. Health & Safety Code §25249.5 et seq.) For further information about Proposition 65: <http://www.oehha.org/prop65.html>.

ORIGINAL ESTIMATE \$	REVISED ESTIMATE \$	ADDITIONAL COST \$	ALL PARTS INSTALLED ARE NEW UNLESS OTHERWISE SPECIFIED.	
REASON		CONTACTED BY	I acknowledge notice and oral approval of an increase in the original estimated price.	I ACKNOWLEDGE RECEIPT OF THE PARTS AND LABOR LISTED BELOW
AUTHORIZED BY	<input type="checkbox"/> PERSON <input type="checkbox"/> PHONE #	DATE	TIME	X _____ CUSTOMER INITIALS
				X _____ CUSTOMER SIGNATURE

Adv: 501 RENE SAZO	Tag	License	1GNSCHKC3 GR	Page 1	Invoice
--------------------	-----	---------	--------------	--------	---------

Invoice to		Driver/Owner Information			
[REDACTED]		[REDACTED]			
For Office Use		Vehicle Information			
Odometer in: 19529	Out: 19532	WAR W	Prelim	16 CHEVROLET SUBURBAN C1500 LT 4DR SUV	
Begin: 06/27/17	Done: 06/30/17	Invoiced: 06/30/17 14:30 RS	Inservice: 12/11/15	Production: 10/26/15	

Customer Concern						
Concern Cause	Correction	Type: W	Operation	Tech	Amount	
25	CUSTOMER STATES PERFORM MULTIPOINT INSPECTION COMPLETED	PERFORMED MULTIPOINT INSPECTION Tech 045 ESCOBAR, MIGUEL	30PT	045	0.00	
			Subtotal			
			TOTAL CHARGE FOR CONCERN 0.00			
40	16007 FRONTAL AIRBAG AND PRETENSIONER NON DEPLOY OPEN CAMP	PROGRAMMED SDM WCC S309A Tech 045 ESCOBAR, MIGUEL	9102276	045 0.3	44.59	
			Subtotal			
			LABOR MECHANICAL 44.59			
			TOTAL CHARGE FOR CONCERN 44.59			
51	CUSTOMER STATES WHEN PRESSING ON BRAKES AND PUMPS BRAKES ON THE 3RD PUMP BRAKE PEDAL GETS HARD AND VEHICLE WON'T STOP. VERIFIED CONCERN LACH OF BRAKE ASSIST VACUUM HOSE HAS OIL, REFERRED TO PI T5361C	REPLACED VACUUM PUMP, VACUUM PUMP HOSE, VACUUM BOOSTER AND MASTER CYLINDER REPLACE 2 BELTS CONCERN IS NO LONGER PRESENT.	2480118	045 2.8	416.16	
Parts	Part Number	PO#	Note	Description	Qty	Sell
	SPO 012669488			PUMP	1	169.48 169.48

Thank You

DISCLAIMER OF WARRANTIES
AS IS: THE ONLY WARRANTIES APPLYING TO THIS PART(S) ARE THOSE WHICH MAY BE OFFERED BY THE MANUFACTURER. THE SELLING DEALER HEREBY EXPRESSLY DISCLAIMS ALL WARRANTIES, EITHER EXPRESS OR IMPLIED INCLUDING ANY IMPLIED WARRANTIES OF MERCHANTABILITY OR FITNESS FOR A PARTICULAR PURPOSE, AND NEITHER ASSUMES NOR AUTHORIZES ANY OTHER PERSON TO ASSUME FOR IT ANY LIABILITY IN CONNECTION WITH THE SALE OF THIS PART(S) AND/OR SERVICE. BUYER SHALL NOT BE ENTITLED TO RECOVER FROM THE SELLING DEALER ANY CONSEQUENTIAL DAMAGES, DAMAGES TO PROPERTY, DAMAGES FOR LOSS OF USE, LOSS OF TIME, LOSS OF PROFIT, OR INCOME, OR ANY OTHER INCIDENTAL DAMAGES.

I HEREBY ACKNOWLEDGE RECEIPT OF THE PARTS AND LABOR LISTED ABOVE

X

5949 Van Nuys Blvd.

KEYES CHEVROLET

Van Nuys, CA 91401

(818) 933-3000

Monday - Friday:
7:00 A.M. - 6:00 P.M.
Saturday:
7:00 A.M. - 5:00 P.M.

EPA #: CAL000386348
BAR #: ARD260656

WARNING - Motor vehicles contain chemicals known to the State of California to cause cancer and birth defects or other reproductive harm. These chemicals are contained in many vehicle components and replacement parts, vehicle fluids, and paints and materials used to maintain vehicles, including, but not limited to, fuel, oil, batteries, brakes, and wheel balancing weights. When you service, clean or maintain your car, you will be exposed to listed chemicals contained in used oil, waste and replacement fluids, fumes, grease, grime, touch-up paint, certain replacement parts, and particulates from component wear. When we service your car, we will return used components to you upon request. Used parts and components contain chemicals known to the State of California to cause cancer and birth defects or other reproductive harm.

To minimize your exposure when servicing, maintaining or cleaning your vehicle: 1) work in a well ventilated area; 2) do not smoke, drink or eat while working; 3) wash your hands when finished or when taking a break; and 4) follow all manufacturer instructions pertaining to proper use and maintenance of motor vehicles and vehicle components.

(Posted in accordance with Proposition 65 in Cal. Health & Safety Code §25249.5 et seq) For further information about Proposition 65: <http://www.oehha.org/prop65.html>.

ORIGINAL ESTIMATE \$	REVISED ESTIMATE \$	ADDITIONAL COST \$	ALL PARTS INSTALLED ARE NEW UNLESS OTHERWISE SPECIFIED.	
REASON		CONTACTED BY	I acknowledge notice and oral approval of an increase in the original estimated price.	I ACKNOWLEDGE RECEIPT OF THE PARTS AND LABOR LISTED BELOW
AUTHORIZED BY	<input type="checkbox"/> PERSON <input type="checkbox"/> PHONE #	DATE	TIME	X _____ CUSTOMER INITIALS
				X _____ CUSTOMER SIGNATURE

Adv: 501 RENE SAZO	Tag	License	1GNSCHKC3 GR	Page 2	Invoice		
Invoice to:			Driver/Owner:				
Invoiced: 06/30/17 14:30:09 RS			16 CHEVROLET SUBURBAN C1500 LT 4DR SUV				
Parts	Part Number	PO#	Note	Description	Qty	Sell	
	SPO 020925765			CYLINDER	1	97.93 97.93	
	SPO 012658178			BELT KIT	1	52.99 52.99	
	SPO 012658179			BELT	1	52.71 52.71	
	SPO 023135228			PIPE	1	51.27 51.27	
	SPO 023135220			BOOSTER	1	111.24 111.24	
Parts: Count		6.00	Allowance:	153.03			
Tech		045 ESCOBAR, MIGUEL					
				CONT CODE : .			
				FAIL CODE : .			
					Subtotal		
					PARTS	535.62	
					LABOR MECHANICAL	416.16	
					TOTAL CHARGE FOR CONCERN	951.78	
Type: W							
Concern 52	CUSTOMER STATES 2 DAYS AGO COMING DOWN HILL AFTER DRIVING FOR 30 MINUTES OR MORE THERE IS A GRINDING NOISE COMING FROM ENGINE COMPARTMENT WHEN DOWN SHIFTING SOUND LIKE METAL ON METAL, AND ALSO WHEN AT TAKE OFF VEHICLE SHIFTS ERRATIC AND AT TIMES REVS HI BEFORE SHIFTING THEN SLAMS INTO GEAR.			Operation		Tech Units	Amount
Cause	CHECK FOR DTC (NONE) CHECK FLUID (OK) ROAD TEST VEHICLE MONITOR SHIFT AND GEAR RATION ALL OK.			52	807	0.0	0.00
Correction	VEHICLE OPERATING AS DESIGNED						
Tech		807 DELGADILLO, JAS					
				CONT CODE : .			
				FAIL CODE : .			
					Subtotal		
					TOTAL CHARGE FOR CONCERN	0.00	
Type: W							
Concern 60	CUSTOMER STATES AS PER STATE LAW, INSPECT AND SET TIRE PRESSURES TO FACTORY SPECIFICATION			Operation		Tech Units	Amount
Cause	.			PSI	045	0.0 *	0.00
Correction	ADJUSTED TIRE PSI TO:FRT LT:35 FRT RT:35 REAR LT:35 REAR RT:35						
Tech		045 ESCOBAR, MIGUEL					
				CONT CODE : .			
				FAIL CODE : .			
					Subtotal		
					TOTAL CHARGE FOR CONCERN	0.00	
Type: W							

DISCLAIMER OF WARRANTIES

AS IS: THE ONLY WARRANTIES APPLYING TO THIS PART(S) ARE THOSE WHICH MAY BE OFFERED BY THE MANUFACTURER. THE SELLING DEALER HEREBY EXPRESSLY DISCLAIMS ALL WARRANTIES, EITHER EXPRESS OR IMPLIED, INCLUDING ANY IMPLIED WARRANTIES OF MERCHANTABILITY OR FITNESS FOR A PARTICULAR PURPOSE, AND NEITHER ASSUMES NOR AUTHORIZES ANY OTHER PERSON TO ASSUME FOR IT ANY LIABILITY IN CONNECTION WITH THE SALE OF THIS PART(S) AND/OR SERVICE. BUYER SHALL NOT BE ENTITLED TO RECOVER FROM THE SELLING DEALER ANY CONSEQUENTIAL DAMAGES, DAMAGES TO PROPERTY, DAMAGES FOR LOSS OF USE, LOSS OF TIME, LOSS OF PROFIT, OR INCOME, OR ANY OTHER INCIDENTAL DAMAGES.

Thank You

I HEREBY ACKNOWLEDGE RECEIPT OF THE PARTS AND LABOR LISTED ABOVE X

5949 Van Nuys Blvd.

KEYES CHEVROLET

Van Nuys, CA 91401

(818) 933-3000

Monday - Friday:
7:00 A.M. - 6:00 P.M.

Saturday:
7:00 A.M. - 5:00 P.M.

EPA #: CAL000386348

BAR #: ARD260656

WARNING - Motor vehicles contain chemicals known to the State of California to cause cancer and birth defects or other reproductive harm. These chemicals are contained in many vehicle components and replacement parts, vehicle fluids, and paints and materials used to maintain vehicles, including, but not limited to, fuel, oil, batteries, brakes, and wheel balancing weights. When you service, clean or maintain your car, you will be exposed to listed chemicals contained in used oil, waste and replacement fluids, fumes, grease, grime, touch-up paint, certain replacement parts, and particulates from component wear. When we service your car, we will return used components to you upon request. Used parts and components contain chemicals known to the State of California to cause cancer and birth defects or other reproductive harm.

To minimize your exposure when servicing, maintaining or cleaning your vehicle: 1) work in a well ventilated area; 2) do not smoke, drink or eat while working; 3) wash your hands when finished or when taking a break; and 4) follow all manufacturer instructions pertaining to proper use and maintenance of motor vehicles and vehicle components.

(Posted in accordance with Proposition 65 in Cal. Health & Safety Code §25249.5 et seq) For further information about Proposition 65: <http://www.oehha.org/prop65.html>.

ORIGINAL ESTIMATE \$	REVISED ESTIMATE \$	ADDITIONAL COST \$	ALL PARTS INSTALLED ARE NEW UNLESS OTHERWISE SPECIFIED.	
REASON		CONTACTED BY	I acknowledge notice and oral approval of an increase in the original estimated price.	I ACKNOWLEDGE RECEIPT OF THE PARTS AND LABOR LISTED BELOW
AUTHORIZED BY	<input type="checkbox"/> PERSON <input type="checkbox"/> PHONE #	DATE	TIME	X _____ CUSTOMER INITIALS
			X _____ CUSTOMER SIGNATURE	

Adv: 501 RENE SAZO	Tag	License	1GNSCHKC3 GR	Page 3 (Last)	Invoice
Invoice to:	Driver/Owner:				
Invoiced: 06/30/17 14:30:09 RS	16 CHEVROLET SUBURBAN C1500 LT 4DR SUV				
Summary of Charges for Invoice			Payment Distribution for Invoice		
PARTS	535.62	TOTAL CHARGE	996.37		
LABOR MECHANICAL	460.75	FAC WARRANTY	996.37		
TOTAL CHARGE	996.37				

If you have any questions - please see RENE SAZO

DISCLAIMER OF WARRANTIES

AS IS: THE ONLY WARRANTIES APPLYING TO THIS PART(S) ARE THOSE WHICH MAY BE OFFERED BY THE MANUFACTURER. THE SELLING DEALER HEREBY EXPRESSLY DISCLAIMS ALL WARRANTIES, EITHER EXPRESS OR IMPLIED, INCLUDING ANY IMPLIED WARRANTIES OF MERCHANTABILITY OR FITNESS FOR A PARTICULAR PURPOSE, AND NEITHER ASSUMES NOR AUTHORIZES ANY OTHER PERSON TO ASSUME FOR IT ANY LIABILITY IN CONNECTION WITH THE SALE OF THIS PART(S) AND/OR SERVICE. BUYER SHALL NOT BE ENTITLED TO RECOVER FROM THE SELLING DEALER ANY CONSEQUENTIAL DAMAGES, DAMAGES TO PROPERTY, DAMAGES FOR LOSS OF USE, LOSS OF TIME, LOSS OF PROFIT, OR INCOME, OR ANY OTHER INCIDENTAL DAMAGES.

Thank You

I HEREBY ACKNOWLEDGE RECEIPT OF THE PARTS AND LABOR LISTED ABOVE X

X _____ CUSTOMER SIGNATURE

5949 Van Nuys Blvd.

KEYES CHEVROLET

Van Nuys, CA 91401

(818) 933-3000

Monday - Friday:
7:00 A.M. - 6:00 P.M.
Saturday:
7:00 A.M. - 5:00 P.M.

EPA #: CAL000386348
BAR #: ARD260656

WARNING - Motor vehicles contain chemicals known to the State of California to cause cancer and birth defects or other reproductive harm. These chemicals are contained in many vehicle components and replacement parts, vehicle fluids, and paints and materials used to maintain vehicles, including, but not limited to, fuel, oil, batteries, brakes, and wheel balancing weights. When you service, clean or maintain your car, you will be exposed to listed chemicals contained in used oil, waste and replacement fluids, fumes, grease, grime, touch-up paint, certain replacement parts, and particulates from component wear. When we service your car, we will return used components to you upon request. Used parts and components contain chemicals known to the State of California to cause cancer and birth defects or other reproductive harm.

To minimize your exposure when servicing, maintaining or cleaning your vehicle: 1) work in a well ventilated area; 2) do not smoke, drink or eat while working; 3) wash your hands when finished or when taking a break; and 4) follow all manufacturer instructions pertaining to proper use and maintenance of motor vehicles and vehicle components.

(Posted in accordance with Proposition 65 in Cal. Health & Safety Code §25249.5 et seq.) For further information about Proposition 65: <http://www.oehha.org/prop65.html>

ORIGINAL ESTIMATE \$	REVISED ESTIMATE \$	ADDITIONAL COST \$	ALL PARTS INSTALLED ARE NEW UNLESS OTHERWISE SPECIFIED.	
REASON		CONTACTED BY	I acknowledge notice and oral approval of an increase in the original estimated price.	I ACKNOWLEDGE RECEIPT OF THE PARTS AND LABOR LISTED BELOW
AUTHORIZED BY	<input type="checkbox"/> PERSON <input type="checkbox"/> PHONE #	DATE	TIME	X _____ CUSTOMER INITIALS
				X _____ CUSTOMER SIGNATURE

Adv: 501 RENE SAZO	Tag	License	1GNSCHKC3G	Page 1	Invoice	
Invoice to			Driver/Owner Information			
[REDACTED]			[REDACTED]			
For Office Use			Vehicle Information			
Odometer in: 19614 Out: 19614		WAR W Prelim	16 CHEVROLET SUBURBAN C1500 LT 4DR SUV			
Begin: 07/01/17	Done: 07/12/17	Invoiced: 07/12/17 13:50 RS	Inservice: 12/11/15	Production: 10/26/15	Sold: 12/11/15	
Customer Concern						
Concern 24	CUSTOMER STATES PERFORM MULTIPOINT INSPECTION COMPLETED			Operation	Tech	Amount
Cause	PERFORMED MULTIPOINT INSPECTION			30PT	807	0.00
Correction	Tech 807 DELGADILLO, JAS					
Type: WM	CONT CODE : . FAIL CODE : .			Subtotal		
				TOTAL CHARGE FOR CONCERN		0.00
Concern 25	CUSTOMER STATES SUPPLIED WITH KEYES CHEVY LOANER CAR PER LOANER CAR AGREEMENT. CUSTOMER IS RESPONSIBLE FOR ALL DAYS AFTER THEIR VEHICLE IS COMPLETED INITIALS _____			Operation	Tech Units	Amount
Cause	5 DAYS OF LOANER			LOANER	999 0.0	0.00
Correction	LOANER CAR RETURNED					
Parts	Part Number	PO#	Note Description	Qty	Sell	
	000 ENTERPRISE	179368	LOANER LOANER	5	42.00	210.00
	Tech 999 TECH, SUBLET		VOID	1 B		
Type: WM	CONT CODE : . FAIL CODE : .			Subtotal		
				LOANER		210.00
				TOTAL CHARGE FOR CONCERN		210.00
Concern 51	CUSTOMER STATES PICK UP VEHICLE ON 6/30/17 AND 5 HOURS LATER TRANSMISSION WOULD NOT MOVE AND MAKES GRINDING NOISE, NO FORWARD GEAR NO REVERSE, WHEN IT DOES GO IS SLAMS INTO GEAR.			Operation	Tech Units	Amount

Thank You

DISCLAIMER OF WARRANTIES
AS IS: THE ONLY WARRANTIES APPLYING TO THIS PART(S) ARE THOSE WHICH MAY BE OFFERED BY THE MANUFACTURER. THE SELLING DEALER HEREBY EXPRESSLY DISCLAIMS ALL WARRANTIES, EITHER EXPRESS OR IMPLIED INCLUDING ANY IMPLIED WARRANTIES OF MERCHANTABILITY OR FITNESS FOR A PARTICULAR PURPOSE, AND NEITHER ASSUMES NOR AUTHORIZES ANY OTHER PERSON TO ASSUME FOR IT ANY LIABILITY IN CONNECTION WITH THE SALE OF THIS PART(S) AND/OR SERVICE. BUYER SHALL NOT BE ENTITLED TO RECOVER FROM THE SELLING DEALER ANY CONSEQUENTIAL DAMAGES, DAMAGES TO PROPERTY, DAMAGES FOR LOSS OF USE, LOSS OF TIME, LOSS OF PROFIT, OR INCOME, OR ANY OTHER INCIDENTAL DAMAGES.

I HEREBY ACKNOWLEDGE RECEIPT OF THE PARTS AND LABOR LISTED ABOVE X

(818) 933-3000

Monday - Friday:
7:00 A.M. - 6:00 P.M.
Saturday:
7:00 A.M. - 5:00 P.M.

EPA #: CAL000386348
BAR #: ARD260656

WARNING - Motor vehicles contain chemicals known to the State of California to cause cancer and birth defects or other reproductive harm. These chemicals are contained in many vehicle components and replacement parts, vehicle fluids, and paints and materials used to maintain vehicles, including, but not limited to, fuel, oil, batteries, brakes, and wheel balancing weights. When you service, clean or maintain your car, you will be exposed to listed chemicals contained in used oil, waste and replacement fluids, fumes, grease, grime, touch-up paint, certain replacement parts, and particulates from component wear. When we service your car, we will return used components to you upon request. Used parts and components contain chemicals known to the State of California to cause cancer and birth defects or other reproductive harm.

To minimize your exposure when servicing, maintaining or cleaning your vehicle: 1) work in a well ventilated area; 2) do not smoke, drink or eat while working; 3) wash your hands when finished or when taking a break; and 4) follow all manufacturer instructions pertaining to proper use and maintenance of motor vehicles and vehicle components.

(Posted in accordance with Proposition 65 in Cal. Health & Safety Code §25249.5 et seq) For further information about Proposition 65: <http://www.oehha.org/prop65.html>.

ORIGINAL ESTIMATE \$	REVISED ESTIMATE \$	ADDITIONAL COST \$	ALL PARTS INSTALLED ARE NEW UNLESS OTHERWISE SPECIFIED.	
REASON		CONTACTED BY	I acknowledge notice and oral approval of an increase in the original estimated price.	I ACKNOWLEDGE RECEIPT OF THE PARTS AND LABOR LISTED BELOW
AUTHORIZED BY	<input type="checkbox"/> PERSON <input type="checkbox"/> PHONE #	DATE	TIME	X _____ CUSTOMER INITIALS
			X _____ CUSTOMER SIGNATURE	

Adv: 501 RENE SAZO	Tag	License	IGNSCHKC3 GR	Page 2	Invoice			
Invoice to:			Driver/Owner:					
Invoiced: 07/12/17 13:50:48 RS			16 CHEVROLET SUBURBAN C1500 LT 4DR SUV					
Cause	CHECK DTC BATTERY FAILED CHECK LINE PRESSURE (60PSI) CHECK FLUID (BURNT) ROAD TEST VEHICLE ONLY 1 GEAR, R&R TRANSMISSION TO INSPECT FLOW TEST COOLER				8466450	807	7.6	1129.59
Correction	(PASSED) DISASSEMBLE TRANSMISSION FOUND ALL CLUTCHES BURNT, INSPECT PUMP FOUND HOUSING SCORE AND CONVERTER OVER HEATED TEST TECHM FOUND FULL OF METAL INSPECT 1-2-3-4- HOUSING FOUND NOT HOLDING AND COMING APART, REPLACED 1-2-3-4 HOUSING COMPLETE, REPLACED 2-6 AND 4-5-6 CLUTCHES REPLACED TORQUE CONVERTER, REPLACE TECHM AND PROGRAM.							
Tech Notes								
Parts	Part Number	PO#	Note	Description	Qty	Sell		
	SPO 024232497			*PLATE	5	10.50	52.50	
	SPO 024240221			*PLATE	5	5.42	27.10	
	000 024259848			CLUTCH	1	270.77	270.77	
	000 024258083			PLATE	6	4.51	27.06	
	000 024224158			PLATE	6	5.38	32.28	
	000 024248573			COVER KIT	1	258.17	258.17	
	000 024248031			HOUSING	1	133.39	133.39	
	000 024248570			ROTOR PKG	1	116.93	116.93	
	000 024224131			SLIDE	1	14.13	14.13	
	000 024247371			CONVERTER	1	336.94	336.94	
	000 024275873			VALVE	1	518.00	518.00	
	000 024236933			FILTER KIT	1	39.72	39.72	
	000 024272475			SEAL KIT	1	86.60	86.60	
	000 088862156		GOG	FLUID	8	3.65	29.20	
	SPO 024224659			*PLATE	1	7.84	7.84	
	000 015077362			SEAL	1	13.33	13.33	
	000 015035747			SEAL	1	14.81	14.81	
	000 015709703			NUT	6	2.10	12.60	
	Parts: Count 40.00		Allowance:	568.97				
	Tech 807 DELGADILLO, JAS							
	CONT CODE : .							
	FAIL CODE : .							
Type: WM					Subtotal			
					PARTS	1962.17		
					GAS-OIL-GREASE	29.20		
					LABOR MECHANICAL	1129.59		
					TOTAL CHARGE FOR CONCERN	3120.96		

Thank You

DISCLAIMER OF WARRANTIES
AS IS: THE ONLY WARRANTIES APPLYING TO THIS PART(S) ARE THOSE WHICH MAY BE OFFERED BY THE MANUFACTURER. THE SELLING DEALER HEREBY EXPRESSLY DISCLAIMS ALL WARRANTIES, EITHER EXPRESS OR IMPLIED, INCLUDING ANY IMPLIED WARRANTIES OF MERCHANTABILITY OR FITNESS FOR A PARTICULAR PURPOSE, AND NEITHER ASSUMES NOR AUTHORIZES ANY OTHER PERSON TO ASSUME FOR IT ANY LIABILITY IN CONNECTION WITH THE SALE OF THIS PART(S) AND/OR SERVICE. BUYER SHALL NOT BE ENTITLED TO RECOVER FROM THE SELLING DEALER ANY CONSEQUENTIAL DAMAGES, DAMAGES TO PROPERTY, DAMAGES FOR LOSS OF USE, LOSS OF TIME, LOSS OF PROFIT, OR INCOME, OR ANY OTHER INCIDENTAL DAMAGES.

I HEREBY ACKNOWLEDGE RECEIPT OF THE PARTS AND LABOR LISTED ABOVE X

5949 Van Nuys Blvd.

KEYES CHEVROLET

Van Nuys, CA 91401

(818) 933-3000

Monday - Friday:
7:00 A.M. - 6:00 P.M.
Saturday:
7:00 A.M. - 5:00 P.M.

EPA #: CAL000386348
BAR #: ARD260656

WARNING - Motor vehicles contain chemicals known to the State of California to cause cancer and birth defects or other reproductive harm. These chemicals are contained in many vehicle components and replacement parts, vehicle fluids, and paints and materials used to maintain vehicles, including, but not limited to, fuel, oil, batteries, brakes, and wheel balancing weights. When you service, clean or maintain your car, you will be exposed to listed chemicals contained in used oil, waste and replacement fluids, fumes, grease, grime, touch-up paint, certain replacement parts, and particulates from component wear. When we service your car, we will return used components to you upon request. Used parts and components contain chemicals known to the State of California to cause cancer and birth defects or other reproductive harm.

To minimize your exposure when servicing, maintaining or cleaning your vehicle: 1) work in a well ventilated area; 2) do not smoke, drink or eat while working; 3) wash your hands when finished or when taking a break; and 4) follow all manufacturer instructions pertaining to proper use and maintenance of motor vehicles and vehicle components.

(Posted in accordance with Proposition 65 in Cal. Health & Safety Code §25249.5 et seq) For further information about Proposition 65: <http://www.oehha.org/prop65.html>.

ORIGINAL ESTIMATE \$	REVISED ESTIMATE \$	ADDITIONAL COST \$	ALL PARTS INSTALLED ARE NEW UNLESS OTHERWISE SPECIFIED.		
REASON		CONTACTED BY	I acknowledge notice and oral approval of an increase in the original estimated price.		I ACKNOWLEDGE RECEIPT OF THE PARTS AND LABOR LISTED BELOW
AUTHORIZED BY	<input type="checkbox"/> PERSON <input type="checkbox"/> PHONE #	DATE	TIME	X _____ CUSTOMER INITIALS	X _____ CUSTOMER SIGNATURE

Adv: 501 RENE SAZO Tag [redacted] License [redacted] 1GNSCHKC3G [redacted] Page 3 Invoice [redacted]

Invoice to: [redacted] Driver/Owner: [redacted]

Invoiced: 07/12/17 13:50:48 RS 16 CHEVROLET SUBURBAN C1500 LT 4DR SUV

Concern 60	CUSTOMER STATES AS PER STATE LAW, INSPECT AND SET TIRE PRESSURES TO FACTORY SPECIFICATION	Operation	Tech Units	Amount
Cause		PSI	807 0.0 *	0.00
Correction	ADJUSTED TIRE PSI TO:FRT LT:35 FRT RT:35 REAR LT:35 REAR RT:35 Tech 807 DELGADILLO, JAS			
Type: WM	Line Auth: SAZORENE 07/12/17 13:09			
		Subtotal		
		TOTAL CHARGE FOR CONCERN		0.00

Concern +62	ADD-ON. 07-11-17 @ 2:36 PM. SHOP FOREMAN VERIFIED VEHICLE WILL NOT CRANK. UNABLE TO JUMP START	Operation	Tech Units	Amount
Cause	FOUND VEHICLE WILL NOT START PERFORM BATTERY LOAD TEST	4041510	807 0.8	118.90
Correction	BATTERY FAILED LOAD.			
Parts	REPLACE BATTERY.			
	Part Number PO# Note Description Qty Sell			
	000 088865934 94R/PG BATTERY 1 180.84 180.84			
	000 00BATTFEE BATFEE ***** 1 B 1.00 1.00			
	Parts: Count 1.00 Allowance: 52.67			
	Tech 807 DELGADILLO, JAS			
Type: WM	CONT CODE : . FAIL CODE : .			
		Subtotal		
		PARTS		180.84
		EPA COMPLIANCE CHG		1.00
		LABOR MECHANICAL		118.90
		TOTAL CHARGE FOR CONCERN		300.74

Summary of Charges for Invoice [redacted]		Payment Distribution for Invoice [redacted]	
PARTS	2143.01	TOTAL CHARGE	3631.70
GAS-OIL-GREASE	29.20		
EPA COMPLIANCE CHG	1.00	FAC WARRANTY	3631.70
LABOR MECHANICAL	1248.49		
LOANER	210.00		
TOTAL CHARGE	3631.70		

If you have any questions - please see RENE SAZO

DISCLAIMER OF WARRANTIES

AS IS: THE ONLY WARRANTIES APPLYING TO THIS PART(S) ARE THOSE WHICH MAY BE OFFERED BY THE MANUFACTURER. THE SELLING DEALER HEREBY EXPRESSLY DISCLAIMS ALL WARRANTIES, EITHER EXPRESS OR IMPLIED, INCLUDING ANY IMPLIED WARRANTIES OF MERCHANTABILITY OR FITNESS FOR A PARTICULAR PURPOSE, AND NEITHER ASSUMES NOR AUTHORIZES ANY OTHER PERSON TO ASSUME FOR IT ANY LIABILITY IN CONNECTION WITH THE SALE OF THIS PART(S) AND/OR SERVICE. BUYER SHALL NOT BE ENTITLED TO RECOVER FROM THE SELLING DEALER ANY CONSEQUENTIAL DAMAGES, DAMAGES TO PROPERTY, DAMAGES FOR LOSS OF USE, LOSS OF TIME, LOSS OF PROFIT, OR INCOME, OR ANY OTHER INCIDENTAL DAMAGES.

Thank You

I HEREBY ACKNOWLEDGE RECEIPT OF THE PARTS AND LABOR LISTED ABOVE X

EPA #: CAL000386348
BAR #: ARD260656

WARNING - Motor vehicles contain chemicals known to the State of California to cause cancer and birth defects or other reproductive harm. These chemicals are contained in many vehicle components and replacement parts, vehicle fluids, and paints and materials used to maintain vehicles, including, but not limited to, fuel, oil, batteries, brakes, and wheel balancing weights. When you service, clean or maintain your car, you will be exposed to listed chemicals contained in used oil, waste and replacement fluids, fumes, grease, grime, touch-up paint, certain replacement parts, and particulates from component wear. When we service your car, we will return used components to you upon request. Used parts and components contain chemicals known to the State of California to cause cancer and birth defects or other reproductive harm.

To minimize your exposure when servicing, maintaining or cleaning your vehicle: 1) work in a well ventilated area; 2) do not smoke, drink or eat while working; 3) wash your hands when finished or when taking a break; and 4) follow all manufacturer instructions pertaining to proper use and maintenance of motor vehicles and vehicle components.

(Posted in accordance with Proposition 65 in Cal. Health & Safety Code §25249.5 et seq.) For further information about Proposition 65: <http://www.oehha.org/prop65.html>.

ORIGINAL ESTIMATE \$	REVISED ESTIMATE \$	ADDITIONAL COST \$	ALL PARTS INSTALLED ARE NEW UNLESS OTHERWISE SPECIFIED.	
REASON		CONTACTED BY	I acknowledge notice and oral approval of an increase in the original estimated price.	I ACKNOWLEDGE RECEIPT OF THE PARTS AND LABOR LISTED BELOW
AUTHORIZED BY	<input type="checkbox"/> PERSON <input type="checkbox"/> PHONE #	DATE	TIME	X _____ CUSTOMER INITIALS
			X _____ CUSTOMER SIGNATURE	

Adv: 501 RENE SAZO	Tag	License	1GNSCHKC3 G	Page 1	Invoice
--------------------	-----	---------	-------------	--------	---------

Invoice to		Driver/Owner Information			
[REDACTED]		[REDACTED]			
For Office Use		Vehicle Information			
Odometer in: 22426	Out: 22426	WAR W C	Prelim	16 CHEVROLET SUBURBAN C1500 LT 4DR SUV	
Begin: 07/26/17	Done: 07/28/17	Invoiced: 07/31/17 11:23 RS	Inservice: 12/11/15	Production: 10/26/15	Sold: 12/11/15

Customer Concern											
Concern	Cause	Correction	Part	Part Number	PO#	Note	Description	Operation	Tech	Units	Amount
24	CUSTOMER STATES SUPPLIED WITH KEYES CHEVY LOANER CAR PER LOANER CAR AGREEMENT. CUSTOMER IS RESPONSIBLE FOR ALL DAYS AFTER THEIR VEHICLE IS COMPLETED INITIALS _____	LOANER CAR RETURNED						LOANER	742	0.0	0.00
					183127		RENTAL	Qty		Sell	
								1		76.00	76.00
Subtotal											
SUBLET REPAIRS											76.00
TOTAL CHARGE FOR CONCERN											76.00
Type: W											
25	CUSTOMER STATES PERFORM MULTIPOINT INSPECTION	PERFORMED MULTIPOINT INSPECTION						30PT	742	0.00	0.00
								Subtotal			
TOTAL CHARGE FOR CONCERN											0.00
Type: WM											
51	CUSTOMER STATES UPON ACCELERATION THERE IS A GRINDING NOISE UNDERNEATH DRIVER SEAT. ALSO NOISE WHEN GOING 65 AND THEN TRYING TO PASS UPON ACCELERATION THERE IS A GRINDING NOISE. OPERATING TEMP AFTER DRIVE FOR 10 TO 15 MILES BUZZING NOISE FROM EXHAUST, SEE RD	ROAD TESTED VEHICLE COULD NOT DUPLICATE GRINDING NOISE. FOUND BUZZING NOISE COMING FROM EXHAUST. RESECURED PIPE TO PIPE MID JOINT CLAMP.						4050272	742	0.0	0.00
									742	0.3	44.59

Thank You

DISCLAIMER OF WARRANTIES
AS IS: THE ONLY WARRANTIES APPLYING TO THIS PART(S) ARE THOSE WHICH MAY BE OFFERED BY THE MANUFACTURER. THE SELLING DEALER HEREBY EXPRESSLY DISCLAIMS ALL WARRANTIES, EITHER EXPRESS OR IMPLIED INCLUDING ANY IMPLIED WARRANTIES OF MERCHANTABILITY OR FITNESS FOR A PARTICULAR PURPOSE, AND NEITHER ASSUMES NOR AUTHORIZES ANY OTHER PERSON TO ASSUME FOR IT ANY LIABILITY IN CONNECTION WITH THE SALE OF THIS PART(S) AND/OR SERVICE. BUYER SHALL NOT BE ENTITLED TO RECOVER FROM THE SELLING DEALER ANY CONSEQUENTIAL DAMAGES, DAMAGES TO PROPERTY, DAMAGES FOR LOSS OF USE, LOSS OF TIME, LOSS OF PROFIT, OR INCOME, OR ANY OTHER INCIDENTAL DAMAGES.

I HEREBY ACKNOWLEDGE RECEIPT OF THE PARTS AND LABOR LISTED ABOVE

X

5949 Van Nuys Blvd.

KEYES CHEVROLET

Van Nuys, CA 91401

(818) 933-3000

Monday - Friday:
7:00 A.M. - 6:00 P.M.
Saturday:
7:00 A.M. - 5:00 P.M.

EPA #: CAL000386348
BAR #: ARD260656

WARNING - Motor vehicles contain chemicals known to the State of California to cause cancer and birth defects or other reproductive harm. These chemicals are contained in many vehicle components and replacement parts, vehicle fluids, and paints and materials used to maintain vehicles, including, but not limited to, fuel, oil, batteries, brakes, and wheel balancing weights. When you service, clean or maintain your car, you will be exposed to listed chemicals contained in used oil, waste and replacement fluids, fumes, grease, grime, touch-up paint, certain replacement parts, and particulates from component wear. When we service your car, we will return used components to you upon request. Used parts and components contain chemicals known to the State of California to cause cancer and birth defects or other reproductive harm.

To minimize your exposure when servicing, maintaining or cleaning your vehicle: 1) work in a well ventilated area; 2) do not smoke, drink or eat while working; 3) wash your hands when finished or when taking a break; and 4) follow all manufacturer instructions pertaining to proper use and maintenance of motor vehicles and vehicle components.

(Posted in accordance with Proposition 65 in Cal. Health & Safety Code §25249.5 et seq) For further information about Proposition 65: <http://www.oehha.org/prop65.html>.

ORIGINAL ESTIMATE \$	REVISED ESTIMATE \$	ADDITIONAL COST \$	ALL PARTS INSTALLED ARE NEW UNLESS OTHERWISE SPECIFIED.	
REASON		CONTACTED BY	I acknowledge notice and oral approval of an increase in the original estimated price.	I ACKNOWLEDGE RECEIPT OF THE PARTS AND LABOR LISTED BELOW
AUTHORIZED BY	<input type="checkbox"/> PERSON <input type="checkbox"/> PHONE #	DATE	TIME	
		X _____ CUSTOMER INITIALS		X _____ CUSTOMER SIGNATURE

Adv: 501 RENE SAZO	Tag	License	IGNSCHKC3 GR	Page 2	Invoice
Invoice to:			Driver/Owner:		
Invoiced: 07/31/17 11:23:48 RS			16 CHEVROLET SUBURBAN C1500 LT 4DR SUV		
Type: W	Tech 742 MUNOZ, MARIO JO			Subtotal LABOR MECHANICAL 44.59 TOTAL CHARGE FOR CONCERN 44.59	
Concern 60	AS PER STATE LAW, INSPECT AND SET TIRE PRESSURES TO FACTORY SPECIFICATION			Operation Tech Units Amount	
Cause	.			PSI 742 0.0 * 0.00	
Correction	ADJUSTED TIRE PSI TO: FRT LT:35 FRT RT:35 REAR LT:35 REAR RT:35			Subtotal	
Type: WM	Tech 742 MUNOZ, MARIO JO			TOTAL CHARGE FOR CONCERN 0.00	
Summary of Charges for Invoice			Payment Distribution for Invoice		
SUBLET REPAIRS 76.00			TOTAL CHARGE 120.59		
LABOR MECHANICAL 44.59			FAC WARRANTY 120.59		
TOTAL CHARGE 120.59					
Attention: The following Invoices also exist CUS - CUSTOMERPAY					
If you have any questions - please see RENE SAZO					

DISCLAIMER OF WARRANTIES
 AS IS: THE ONLY WARRANTIES APPLYING TO THIS PART(S) ARE THOSE WHICH MAY BE OFFERED BY THE MANUFACTURER. THE SELLING DEALER HEREBY EXPRESSLY DISCLAIMS ALL WARRANTIES, EITHER EXPRESS OR IMPLIED, INCLUDING ANY IMPLIED WARRANTIES OF MERCHANTABILITY OR FITNESS FOR A PARTICULAR PURPOSE, AND NEITHER ASSUMES NOR AUTHORIZES ANY OTHER PERSON TO ASSUME FOR IT ANY LIABILITY IN CONNECTION WITH THE SALE OF THIS PART(S) AND/OR SERVICE. BUYER SHALL NOT BE ENTITLED TO RECOVER FROM THE SELLING DEALER ANY CONSEQUENTIAL DAMAGES, DAMAGES TO PROPERTY, DAMAGES FOR LOSS OF USE, LOSS OF TIME, LOSS OF PROFIT, OR INCOME, OR ANY OTHER INCIDENTAL DAMAGES.

Thank You

I HEREBY ACKNOWLEDGE RECEIPT OF THE PARTS AND LABOR LISTED ABOVE X

EPA #: CAL000386348
BAR #: ARD260656

WARNING - Motor vehicles contain chemicals known to the State of California to cause cancer and birth defects or other reproductive harm. These chemicals are contained in many vehicle components and replacement parts, vehicle fluids, and paints and materials used to maintain vehicles, including, but not limited to, fuel, oil, batteries, brakes, and wheel balancing weights. When you service, clean or maintain your car, you will be exposed to listed chemicals contained in used oil, waste and replacement fluids, fumes, grease, grime, touch-up paint, certain replacement parts, and particulates from component wear. When we service your car, we will return used components to you upon request. Used parts and components contain chemicals known to the State of California to cause cancer and birth defects or other reproductive harm.

To minimize your exposure when servicing, maintaining or cleaning your vehicle: 1) work in a well ventilated area; 2) do not smoke, drink or eat while working; 3) wash your hands when finished or when taking a break; and 4) follow all manufacturer instructions pertaining to proper use and maintenance of motor vehicles and vehicle components.

(Posted in accordance with Proposition 65 in Cal. Health & Safety Code §25249.5 et seq.) For further information about Proposition 65: <http://www.oehha.org/prop65.html>.

ORIGINAL ESTIMATE \$	REVISED ESTIMATE \$	ADDITIONAL COST \$	ALL PARTS INSTALLED ARE NEW UNLESS OTHERWISE SPECIFIED.	
REASON		CONTACTED BY	I acknowledge notice and oral approval of an increase in the original estimated price.	I ACKNOWLEDGE RECEIPT OF THE PARTS AND LABOR LISTED BELOW
AUTHORIZED BY	<input type="checkbox"/> PERSON <input type="checkbox"/> PHONE #	DATE	TIME	X _____ CUSTOMER INITIALS
			X _____ CUSTOMER SIGNATURE	

Adv: 501 RENE SAZO	Tag	License	1GNSCHKC3 GR	Page 1	Invoice
--------------------	-----	---------	--------------	--------	---------

Invoice to		Driver/Owner Information			
[REDACTED]		[REDACTED]			
For Office Use		Vehicle Information			
Odometer in: 26031	Out: 26045	WAR W	Prelim	16 CHEVROLET SUBURBAN C1500 LT 4DR SUV	
Begin: 12/26/17	Done: 01/08/18	Invoiced: 01/09/18 09:41 RS	Inservice: 12/11/15	Production: 10/26/15	Sold: 12/11/15

Customer Concern					
Concern	Cause	Correction	Operation	Tech Units	Amount
24	CUSTOMER STATES PROVIDE CUSTOMER WITH A SHUTTLE RIDE FROM AND TO THE DEALERSHIP BOTH WAYS.	SHUTTLE RIDE PROVIDED Tech 999 TECH, SUBLET	24	999 0.0	0.00
Type: WM			Subtotal		
			TOTAL CHARGE FOR CONCERN	0.00	
25	CUSTOMER STATES PERFORM MULTIPOINT INSPECTION COMPLETED.	PERFORMED MULTIPOINT INSPECTION Tech 742 MUNOZ, MARIO JO	30PT	742	0.00
Type: WM			Subtotal		
			TOTAL CHARGE FOR CONCERN	0.00	
+26	CUSTOMER STATES SUPPLIED WITH KEYES CHEVY LOANER CAR PER LOANER CAR AGREEMENT. CUSTOMER IS RESPONSIBLE FOR ALL DAYS AFTER THEIR VEHICLE IS COMPLETED INITIALS _____	13 DAYS OF LOANER LOANER CAR RETURNED	LOANER	999 0.0	0.00
Parts			Qty	Sell	
Part Number			13	42.00	546.00
Tech 999 TECH, SUBLET			Subtotal		
Line Auth: 01/09/18 09:35			LOANER	546.00	
Type: WM			TOTAL CHARGE FOR CONCERN	546.00	

DISCLAIMER OF WARRANTIES
AS IS: THE ONLY WARRANTIES APPLYING TO THIS PART(S) ARE THOSE WHICH MAY BE OFFERED BY THE MANUFACTURER. THE SELLING DEALER HEREBY EXPRESSLY DISCLAIMS ALL WARRANTIES, EITHER EXPRESS OR IMPLIED, INCLUDING ANY IMPLIED WARRANTIES OF MERCHANTABILITY OR FITNESS FOR A PARTICULAR PURPOSE, AND NEITHER ASSUMES NOR AUTHORIZES ANY OTHER PERSON TO ASSUME FOR IT ANY LIABILITY IN CONNECTION WITH THE SALE OF THIS PART(S) AND/OR SERVICE. BUYER SHALL NOT BE ENTITLED TO RECOVER FROM THE SELLING DEALER ANY CONSEQUENTIAL DAMAGES, DAMAGES TO PROPERTY, DAMAGES FOR LOSS OF USE, LOSS OF TIME, LOSS OF PROFIT, OR INCOME, OR ANY OTHER INCIDENTAL DAMAGES.

Thank You

I HEREBY ACKNOWLEDGE RECEIPT OF THE PARTS AND LABOR LISTED ABOVE X

EPA #: CAL000386348
BAR #: ARD260656

WARNING - Motor vehicles contain chemicals known to the State of California to cause cancer and birth defects or other reproductive harm. These chemicals are contained in many vehicle components and replacement parts, vehicle fluids, and paints and materials used to maintain vehicles, including, but not limited to, fuel, oil, batteries, brakes, and wheel balancing weights. When you service, clean or maintain your car, you will be exposed to listed chemicals contained in used oil, waste and replacement fluids, fumes, grease, grime, touch-up paint, certain replacement parts, and particulates from component wear. When we service your car, we will return used components to you upon request. Used parts and components contain chemicals known to the State of California to cause cancer and birth defects or other reproductive harm.

To minimize your exposure when servicing, maintaining or cleaning your vehicle: 1) work in a well ventilated area; 2) do not smoke, drink or eat while working; 3) wash your hands when finished or when taking a break; and 4) follow all manufacturer instructions pertaining to proper use and maintenance of motor vehicles and vehicle components.

(Posted in accordance with Proposition 65 in Cal. Health & Safety Code §25249.5 et seq.) For further information about Proposition 65: <http://www.oahha.org/prop65.html>.

ORIGINAL ESTIMATE \$	REVISED ESTIMATE \$	ADDITIONAL COST \$	ALL PARTS INSTALLED ARE NEW UNLESS OTHERWISE SPECIFIED.	
REASON		CONTACTED BY	I acknowledge notice and oral approval of an increase in the original estimated price.	I ACKNOWLEDGE RECEIPT OF THE PARTS AND LABOR LISTED BELOW
AUTHORIZED BY	<input type="checkbox"/> PERSON <input type="checkbox"/> PHONE #	DATE	TIME	X _____ CUSTOMER INITIALS
			X _____ CUSTOMER SIGNATURE	

Adv: 501 RENE SAZO	Tag	License	1GNSCHKC3 GR	Page 2	Invoice	
Invoice to:	Driver/Owner:					
Invoiced: 01/09/18 09:41:49 RS	16 CHEVROLET SUBURBAN C1500 LT 4DR SUV					
Concern 51	CUSTOMER STATES ENGINE MOUNTS ARE BROKEN CHECK AND ADVISE.			Operation	Tech Units	Amount
Cause	INSPECTED VEHICLE FOUND LEFT ENGINE MOUNT COMING APART			4067080	742 2.3	350.41
Correction	REMOVED AND REPLACED LEFT ENGINE MOUNT					
Parts	Part Number	PO#	Note	Description	Qty	Sell
	000 011516754			NUT	1	4.54 4.54
	000 011516780			NUT	1	0.85 0.85
	000 011514596			NUT	2	3.70 7.40
	SPO 084175583			MOUNT	1	91.04 91.04
	SPO 023492578			HOSE	1	45.72 45.72
	Parts: Count	6.00	Allowance:	42.73		
	Tech	742 MUNOZ, MARIO JO				
Type: w				Subtotal		
				PARTS		149.55
				LABOR MECHANICAL		350.41
				TOTAL CHARGE FOR CONCERN		499.96
Concern 52	CUSTOMER STATES OIL LEAKS ON DRIVE WAY CHECK AND ADVISE.			Operation	Tech Units	Amount
Cause	INSPECTED VEHICLE FOUND LOWER OIL PAN LEAKING			4065910	742 1.3	198.06
Correction	REMOVED AND RESEALED LOWER OIL PAN					
Parts	Part Number	PO#	Note	Description	Qty	Sell
	000 088864346			SEALANT	1	11.00 11.00
	Parts: Count	1.00	Allowance:	3.14		
	Tech	742 MUNOZ, MARIO JO				
Type: w				Subtotal		
				PARTS		11.00
				LABOR MECHANICAL		198.06
				TOTAL CHARGE FOR CONCERN		209.06
Concern 53	CUSTOMER STATES SLIGHT GRIND NOISE WHEN GOING UP HILL,			Operation	Tech Units	Amount
Cause	REFER TO LINE 54			LINE54	742 0.0	0.00
Correction	REFER TO LINE 54					
Parts	Part Number	PO#	Note	Description	Qty	Sell
	000 024237556		187367	*HOUSING	1	148.48 148.48
	000 023135703		SPO	*SEAL -SPO	1	
	Parts: Count	2.00	Allowance:	42.42		
	Tech	742 MUNOZ, MARIO JO				
Type: w				Subtotal		
				PARTS		148.48

Thank You

DISCLAIMER OF WARRANTIES
AS IS: THE ONLY WARRANTIES APPLYING TO THIS PART(S) ARE THOSE WHICH MAY BE OFFERED BY THE MANUFACTURER. THE SELLING DEALER HEREBY EXPRESSLY DISCLAIMS ALL WARRANTIES, EITHER EXPRESS OR IMPLIED INCLUDING ANY IMPLIED WARRANTIES OF MERCHANTABILITY OR FITNESS FOR A PARTICULAR PURPOSE, AND NEITHER ASSUMES NOR AUTHORIZES ANY OTHER PERSON TO ASSUME FOR IT ANY LIABILITY IN CONNECTION WITH THE SALE OF THIS PART(S) AND/OR SERVICE. BUYER SHALL NOT BE ENTITLED TO RECOVER FROM THE SELLING DEALER ANY CONSEQUENTIAL DAMAGES, DAMAGES TO PROPERTY, DAMAGES FOR LOSS OF USE, LOSS OF TIME, LOSS OF PROFIT, OR INCOME, OR ANY OTHER INCIDENTAL DAMAGES.

I HEREBY ACKNOWLEDGE RECEIPT OF THE PARTS AND LABOR LISTED ABOVE

X

5949 Van Nuys Blvd.

KEYES CHEVROLET

Van Nuys, CA 91401

(818) 933-3000

Monday - Friday:
7:00 A.M. - 6:00 P.M.
Saturday:
7:00 A.M. - 5:00 P.M.

EPA #: CAL000386348
BAR #: ARD260656

WARNING - Motor vehicles contain chemicals known to the State of California to cause cancer and birth defects or other reproductive harm. These chemicals are contained in many vehicle components and replacement parts, vehicle fluids, and paints and materials used to maintain vehicles, including, but not limited to, fuel, oil, batteries, brakes, and wheel balancing weights. When you service, clean or maintain your car, you will be exposed to listed chemicals contained in used oil, waste and replacement fluids, fumes, grease, grime, touch-up paint, certain replacement parts, and particulates from component wear. When we service your car, we will return used components to you upon request. Used parts and components contain chemicals known to the State of California to cause cancer and birth defects or other reproductive harm.

To minimize your exposure when servicing, maintaining or cleaning your vehicle: 1) work in a well ventilated area; 2) do not smoke, drink or eat while working; 3) wash your hands when finished or when taking a break; and 4) follow all manufacturer instructions pertaining to proper use and maintenance of motor vehicles and vehicle components.

(Posted in accordance with Proposition 65 in Cal. Health & Safety Code §25249.5 et seq) For further information about Proposition 65: <http://www.oehha.org/prop65.html>.

ORIGINAL ESTIMATE \$	REVISED ESTIMATE \$	ADDITIONAL COST \$	ALL PARTS INSTALLED ARE NEW UNLESS OTHERWISE SPECIFIED.	
REASON		CONTACTED BY	I acknowledge notice and oral approval of an increase in the original estimated price.	I ACKNOWLEDGE RECEIPT OF THE PARTS AND LABOR LISTED BELOW
AUTHORIZED BY	<input type="checkbox"/> PERSON <input type="checkbox"/> PHONE #	DATE	TIME	X _____ CUSTOMER INITIALS
				X _____ CUSTOMER SIGNATURE

Adv: 501 RENE SAZO	Tag	License	1GNSCHKC3 GR	Page 3	Invoice
Invoice to			Driver/owner		
Invoiced: 01/09/18 09:41:49 RS			16 CHEVROLET SUBURBAN C1500 LT 4DR SUV		
Type: w					TOTAL CHARGE FOR CONCERN 148.48
Concern 54	CUSTOMER STATES THERE IS A DELAY IN SHIFTING WHEN SHIFTING FROM DRIVE TO REVERSE AND FROM REVERSE TO DRIVE. SM DROVE WITH CLIENT.				Operation Tech Units Amount
Cause	SCAN VEHICLE FOR CODES P0989 CURRENT DIAG DTC W/DOC #2654753 FOLLOW ALL STEP THRU DOCUMENT FOUND TRANSMISSION CONTROL MODULE FAULTY, WHEN REMOVING....				8468030 304 7.3 1085.00
Correction	4-5-6 CLUTCH HUB REPLACEMENT ALL CLUTCHES SEAL AND GASKET, TRANSMISSION CONTROL MODULE DISASSEMBLE VALVE BODY FOR INSPECTION: REASSEMBLE AND CLEAN UP. RECON TRANSMISSION, FLUSH TRANSMISSION COOLER -LINES REPROGRAM TRANSMISSION CONTROL MODULE. ROAD TEST VEHICLE FOR 8 MILES.. IN 26031 OUT 26039.				
Tech Notes	TRANS PAN FOUND DARKEN CLUTCH DEBRIE. REMOVE TRANSMISSION FOR INSP: 4=5=6 CLUTCH HOUSING DAMAGED, 4-5-6 CLUTCH AND 1-2-3-4 CLUTCH BURNT.				
Comment	FLUSH CODE 1.3 GPM 69'F CYCLE 1841 CB67EA0				
Parts	Part Number	PO#	Note	Description	Qty Sell
	000 088862156		GOG	FLUID	16 3.74 59.84
	000 024272475			SEAL KIT	1 86.60 86.60
	000 024248008			PLATE KIT	1 90.97 90.97
	000 024258083		INSF	PLATE	6 4.56 27.36
	000 024236933			FILTER KIT	1 39.72 39.72
	000 024272467		187362	PLATE PKG	1 13.89 13.89
	000 024275873			VALVE	1 525.00 525.00
	SPO 024275873			VALVE	1 525.00 525.00
	Parts: Count	12.00	Allowance:	390.97	
	Tech	304	GARCIA, BEN		
Type: w					Subtotal
Concern 60	AS PER STATE LAW, INSPECT AND SET TIRE PRESSURES TO FACTORY SPECIFICATION COMPLETED				PARTS 1308.54
Cause	ADJUSTED TIRE PSI TO:FRT LT:35 FRT RT:35 REAR LT:35 REAR RT:35				GAS-OIL-GREASE 59.84
Correction					LABOR MECHANICAL 1085.00
					TOTAL CHARGE FOR CONCERN 2453.38
					Operation Tech Units Amount
					PSI 742 0.0 * 0.00

Thank You

DISCLAIMER OF WARRANTIES
AS IS: THE ONLY WARRANTIES APPLYING TO THIS PART(S) ARE THOSE WHICH MAY BE OFFERED BY THE MANUFACTURER. THE SELLING DEALER HEREBY EXPRESSLY DISCLAIMS ALL WARRANTIES, EITHER EXPRESS OR IMPLIED, INCLUDING ANY IMPLIED WARRANTIES OF MERCHANTABILITY OR FITNESS FOR A PARTICULAR PURPOSE, AND NEITHER ASSUMES NOR AUTHORIZES ANY OTHER PERSON TO ASSUME FOR IT ANY LIABILITY IN CONNECTION WITH THE SALE OF THIS PART(S) AND/OR SERVICE. BUYER SHALL NOT BE ENTITLED TO RECOVER FROM THE SELLING DEALER ANY CONSEQUENTIAL DAMAGES, DAMAGES TO PROPERTY, DAMAGES FOR LOSS OF USE, LOSS OF TIME, LOSS OF PROFIT, OR INCOME, OR ANY OTHER INCIDENTAL DAMAGES.

I HEREBY ACKNOWLEDGE RECEIPT OF THE PARTS AND LABOR LISTED ABOVE X

5949 Van Nuys Blvd.

KEYES CHEVROLET

Van Nuys, CA 91401

(818) 933-3000

Monday - Friday:
7:00 A.M. - 6:00 P.M.
Saturday:
7:00 A.M. - 5:00 P.M.

EPA #: CAL000386348
BAR #: ARD260656

WARNING - Motor vehicles contain chemicals known to the State of California to cause cancer and birth defects or other reproductive harm. These chemicals are contained in many vehicle components and replacement parts, vehicle fluids, and paints and materials used to maintain vehicles, including, but not limited to, fuel, oil, batteries, brakes, and wheel balancing weights. When you service, clean or maintain your car, you will be exposed to listed chemicals contained in used oil, waste and replacement fluids, fumes, grease, grime, touch-up paint, certain replacement parts, and particulates from component wear. When we service your car, we will return used components to you upon request. Used parts and components contain chemicals known to the State of California to cause cancer and birth defects or other reproductive harm.

To minimize your exposure when servicing, maintaining or cleaning your vehicle: 1) work in a well ventilated area; 2) do not smoke, drink or eat while working; 3) wash your hands when finished or when taking a break; and 4) follow all manufacturer instructions pertaining to proper use and maintenance of motor vehicles and vehicle components.

(Posted in accordance with Proposition 65 in Cal. Health & Safety Code §25249.5 et seq) For further information about Proposition 65: <http://www.oehha.org/prop65.html>.

ORIGINAL ESTIMATE \$	REVISED ESTIMATE \$	ADDITIONAL COST \$	ALL PARTS INSTALLED ARE NEW UNLESS OTHERWISE SPECIFIED.	
REASON		CONTACTED BY	I acknowledge notice and oral approval of an increase in the original estimated price.	I ACKNOWLEDGE RECEIPT OF THE PARTS AND LABOR LISTED BELOW
AUTHORIZED BY	<input type="checkbox"/> PERSON <input type="checkbox"/> PHONE #	DATE	TIME	X _____ CUSTOMER INITIALS
			X _____ CUSTOMER SIGNATURE	

Adv: 501 RENE SAZO	Tag	License	1GNSCHKC3 GR	Page 4	Invoice
--------------------	-----	---------	--------------	--------	---------

Invoice to:	Driver/Owner:
-------------	---------------

Invoiced: 01/09/18 09:41:49 RS	16 CHEVROLET SUBURBAN C1500 LT 4DR SUV
--------------------------------	--

Type: WM	Tech 742 MUNOZ, MARIO JO	Subtotal	
Concern +62	ADD-ON. 12-28-17 @ 9:05 AM. SHOP FOREMAN VERIFIED ENGINE COOLANT LEAK AT INLET HEATER HOSE.	TOTAL CHARGE FOR CONCERN	0.00
Cause	INSPECTED VEHICLE FOUND INLET HEATER HOSE LEAKING	Operation	Tech Units
Correction	REMOVED AND REPLACED INLET HEATER HOSE, FILLED COOLING SYSTEM RAODTEST END MILEAGE 26043	4413100	742 1.0
	Tech 742 MUNOZ, MARIO JO	Amount	152.35
	Part Auth: GARCIAPE 01/08/18 16:18	Subtotal	
Type: w		LABOR MECHANICAL	152.35
		TOTAL CHARGE FOR CONCERN	152.35

Summary of Charges for Invoice		Payment Distribution for Invoice	
PARTS	1617.57	TOTAL CHARGE	4009.23
GAS-OIL-GREASE	59.84	FAC WARRANTY	4009.23
LABOR MECHANICAL	1785.82		
LOANER	546.00		
TOTAL CHARGE	4009.23		

X065T1DV80:CC created 2017-12-20 11:32:00am taken by Ana Bonilla
If you have any questions - please see RENE SAZO

DISCLAIMER OF WARRANTIES
AS IS: THE ONLY WARRANTIES APPLYING TO THIS PART(S) ARE THOSE WHICH MAY BE OFFERED BY THE MANUFACTURER. THE SELLING DEALER HEREBY EXPRESSLY DISCLAIMS ALL WARRANTIES, EITHER EXPRESS OR IMPLIED INCLUDING ANY IMPLIED WARRANTIES OF MERCHANTABILITY OR FITNESS FOR A PARTICULAR PURPOSE, AND NEITHER ASSUMES NOR AUTHORIZES ANY OTHER PERSON TO ASSUME FOR IT ANY LIABILITY IN CONNECTION WITH THE SALE OF THIS PART(S) AND/OR SERVICE. BUYER SHALL NOT BE ENTITLED TO RECOVER FROM THE SELLING DEALER ANY CONSEQUENTIAL DAMAGES, DAMAGES TO PROPERTY, DAMAGES FOR LOSS OF USE, LOSS OF TIME, LOSS OF PROFIT, OR INCOME, OR ANY OTHER INCIDENTAL DAMAGES.

Thank You

I HEREBY ACKNOWLEDGE RECEIPT OF THE PARTS AND LABOR LISTED ABOVE X