

PE18-004

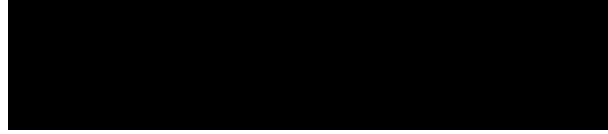

06-19-2018

Material Request Number 7

Service Bulletin 54-287

FLA COE
FLB COE
FLD Conventional
Business Class
FLC 112 Conventional

Century Class Conventional
Argosy COE
Cargo
Columbia

> 122SD and Coronado
> Business Class M2
> Cascadia
> 108SD/114SD

**Freightliner
Service Bulletin**

General Information

Some powernet distribution box (PNDB) modules may experience poor fuse retention on the keep-alive circuits. This could cause intermittent operation of any devices supplied by these circuits. On units equipped with remote sense, it could result in the alternator overcharging, even on alternators capable of self-regulating.

NOTE: A self-regulating alternator may substitute the voltage reading from its primary battery positive, in the event that the remote sense line is a constant open circuit.

If the fuses are not seating properly on the keep-alive circuits, or are falling out, use the instructions in this bulletin to replace the PNDB.

PNDB Replacement

NOTE: The powernet distribution box (PNDB) is located on the cab frontwall, above the main ground junction block. See [Fig. 1](#).

1. Disconnect all batteries. If the vehicle is equipped with an auxiliary battery bank, disconnect these batteries as well.
2. Open the hood.

IMPORTANT: Inspect the keep-alive and cab load disconnect switch (CLDS) connectors and make sure that the plugs are in unused connector cavities. Install plugs to seal the connector if any are missing.

3. Disconnect the cab load disconnect switch (CLDS) connector, if equipped.
4. Disconnect the keep-alive circuit connector from the PNDB.
 - 4.1 Using a flat-head screwdriver, push the red locking tab up.
 - 4.2 Press and release the tab, then remove the connector. See [Fig. 2](#).
5. Disconnect the power cables from the PNDB.
6. Remove the PNDB.
7. Position the new PNDB on the frontwall, and attach the two mounting nuts.
8. Attach the keep-alive circuit connector and the CLDS connector.
9. Connect the power cables. Torque the nut 15 lbf·ft (20 N·m).
10. Connect all batteries, including the auxiliary batteries, if equipped.
11. Close the hood.

Warranty

This procedure is warrantable only if the described condition exists and the repair is performed within the applicable base or extended coverage warranty period. If a failure is not found, this procedure is considered preventive and warranty does not apply.

Normal warranty applies. See [Table 1](#) for OWL VMRS codes and labor allowance information. Enter this service bulletin number in the *Service Bulletin #* field.

54-287

Powernet Distribution Box Fuse Retention on the Keep-Alive Circuit

Freightliner Service Bulletin

FLA COE
 FLB COE
 FLD Conventional
 Business Class
 FLC 112 Conventional

Century Class Conventional
 Argosy COE
 Cargo
 Columbia

> 122SD and Coronado
 > Business Class M2
 > Cascadia
 > 108SD/114SD

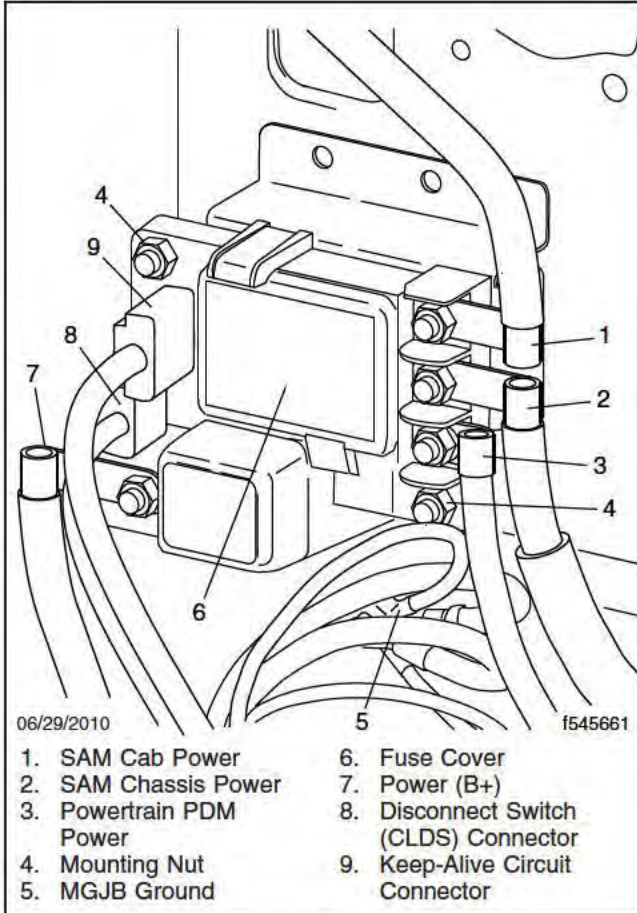

Fig. 1, Powernet Distribution Box

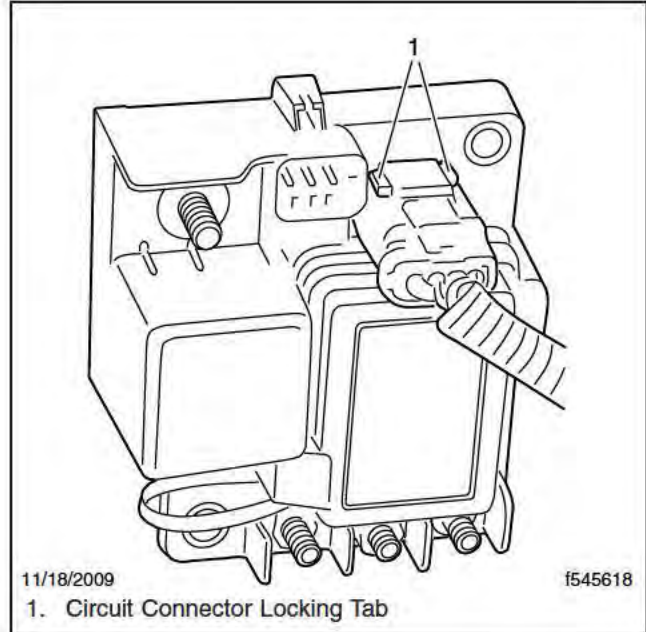

Fig. 2, Removing the Circuit Connector

OWL VMRS Codes and Labor Allowance					
Primary Failed Part	Component Code	Cause Code	SRT Code	Description	Time: Hours
Powernet Distribution Box	034-004-181	23	285-5025A	Powernet Distribution Box, Inspection, R/R	0.5

Table 1, OWL VMRS Codes and Labor Allowance

PE18-004



06-19-2018

Material Request Number 7

Service Solution 3615

SS 3615 PowerNet Distribution Box (PNDB) Positive Disconnect Switch Overview

APPLICABILITY:

This solution applies to any vehicle with a PNDB component (typically EPA2010 vehicles) using a "Positive Disconnect" switch. A separate solution will be written for the "Negative Disconnect" switch. The PNDB was developed to replace the MFJB (Mega Fuse Junction Block), that was previously used.

OVERVIEW:

Operation: If a disconnect switch is present, the LED (Light Emitting Diode) located on the PNDB and the disconnect switch should be illuminated when the switch is on and not illuminated when the switch is off.

There are several different PNDB configurations.

1. PNDB without a cut off switch is basically a junction box with fuses (Reference attachment PNDB W/O Cut Off Switch).
2. Main PNDB with cut off switch (Reference attached "PNDB Casca ia Positive Disconnect" for an example of the schematic and "PNDB Cut Off Switch" for a picture of the switch). To see the PNDB see attached "PNDB With Cut Off Switch".
3. Auxiliary PNDB with cut off switch(Reference attached "Auxiliar PNDB" to see a schematic and "PNDB Auxiliary cut off switch" to view the switch).

ISSUE:

A condition could occur where PNDB with the bi-stable solenoid (no power required hold the relay in an on or off state) flashes the red LED located on PNDB as well as red LED lamp located on the cut off switch (see Attached f "LED Flashing" for reasons why the LED lamp would flash).

ADDITIONAL METHODOLOGY:

To test the PNDB to see if it is bad use the attached "PNDB Test Example" to validate if the PNDB is bad.

ADDITIONAL INFORMATION:

Module Location

PNDB and Auxiliary PNDB parts found in module 33P

Auxiliary PNDB power supply and mounting found in module 33M

PNDB power supply and mounting found in module 29A

Cut off switch and harness found in module 293

Aux Cab power from battery to under cab 87P

P/N for MIDI Fuses

23-13648-100= 100 amp (Blue)

23-13648-125= 125 amp (Pink)

23-13648-150= 150 amp (Gray)

23-13648-175= 175 amp (Green)

SS 3615 PowerNet Distribution Box (PNDB) Positive Disconnect Switch Overview

23-13648-200= 200 amp (Violet)

Additional Note:

On Cascadia Vehicles with EPA10 engines, which used the SAM Software 6.0, the need for a load disconnect switch is no longer required. Due to cable routing conflicts with the MGJB (Mega Ground Junction Block) a PNDB with solenoid is still being used. The PNDB P/N A06-75148-009 or A06-75148-010 look the same as all of the other PNDDBs with Solenoids, only these PNDB are always shipped with solenoid contacts closed and the solenoid wiring is not hooked up internally. If a cut off switch were to be added, the PNDB would also need to be replaced with a PNDB that has the solenoid connected. Example, PNDB A06-75148-009 would need to be replaced by A06-75148-000 and PNDB A06-75148-010, would need to be replaced by A06-75148-011.

Solution ID: 3615

Confidential

The following list highlights the issues that may cause a blinking LED:

- 1) The PNDB unit attempted to turn ON and failed after 5 attempts (during the 5 attempts the LED will double-blink) (low voltage could cause this issue)
- 2) The PNDB unit attempted to turn OFF and failed after 5 attempts (during the 5 attempts the LED will double-blink) (low voltage could cause this issue)
- 3) If the Control Signal Output (PNDB Pin #4) were disconnected, cut, or had such a high resistance to indicate an open circuit
- 4) If the Control Signal Output (CLDS Pin #1 of the 4 Pos Connector) were disconnected, cut, or had such a high resistance to indicate an open circuit
- 5) If the Input Signal (PNDB Pin #5) were disconnected, cut, or had such a high resistance to indicate an open circuit
- 6) If the Input Signal (CLDS Pin #2 of the 4 Pos Connector or Pin #1 of the 3 Pos Connector) were disconnected, cut, or had such a high resistance to indicate an open circuit.
- 7) If either the CLDS control connector or the PNDB control connector were not fully mated to the devices.

Issues #1 & #2 indicate an internal failure of the device, whether electrical or mechanical. If issues #3 through #7 are eliminated by verifying continuity and the integrity of the male-female terminal connections (no corrosion on terminals), then the unit probably has an internal problem and should be replaced.

The PNDB does not flash for an under voltage or an over voltage condition. Testing internally has shown the device will maintain a steady LED at battery voltages as low as 4 Vdc and sometimes even less and operates as low as 7.5 Vdc. It will also maintain operational awareness at voltages as high as 32 Vdc and operate at that same voltage, although the ability for products to operate outside of the normal 12 Vdc to 18 Vdc range is not guaranteed.

Note: If there is a 12 volt back feed on any of the output studs, and the PNDB is in an off state, then the PNDB will not turn on. This is because the PNDB monitors the output and if any voltage is present, it thinks the bi-stable relay is on.

PowerNet Distribution Box (PNDB) Wiring (Cascadia)

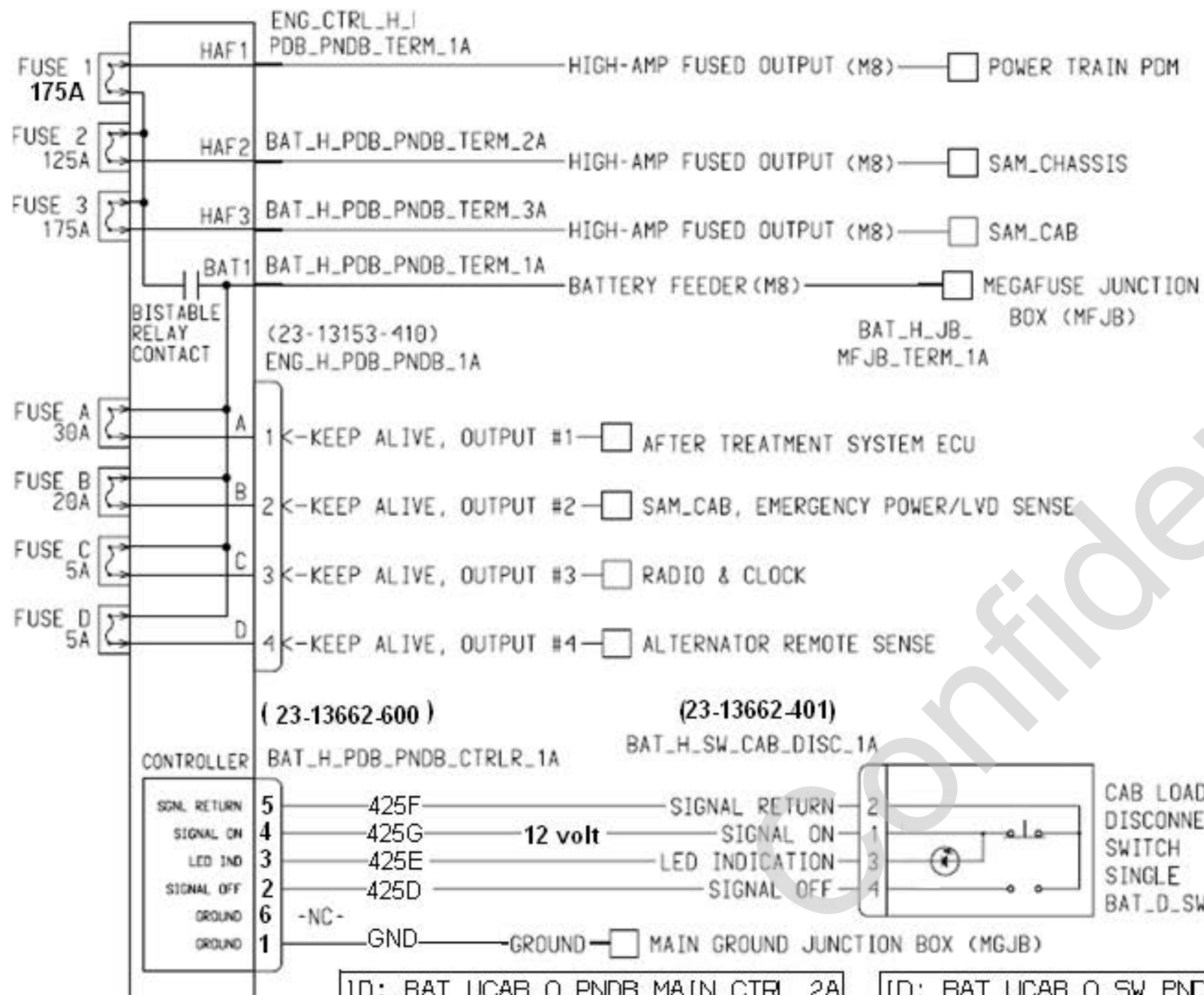

Label 24-01665-000

PNDB WITH C/O SW				
D	C	FUSE	AMPS	DESCRIPTION
	3	A	30	AFT TREATMENT ECU
		B	20	EMERGENCY POWER
	2	C	05	RADIO AND CLOCK
		D	05	ALT REMOTE SENSE
	1	1	175	POWER TRAIN PDM
		2	125	SAM CHASSIS
		3	175	SAM CAB

-000 (P3)

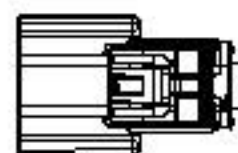
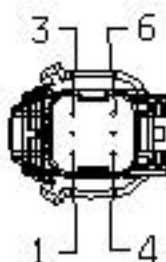

ID:	BAT_UCAB_O_PNDB_MAIN_CTRL_2A
PN:	23-13662-600
Cav	CIR #
1	GNDE
2	425D
3	425E
4	425G
5	425F

ID:	BAT_UCAB_O_SW_PNDB_1A
PN:	23-13662-401
Cav	CIR #
1	425G
2	425F
3	425E
4	425D

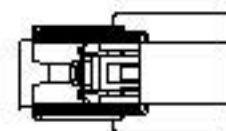

CONNECTOR END VIEW ARE SHOWN FROM THE CABLE INSERTION END

PowerNet Distribution Box (PNDB) Wiring

(Cascadia Example)

Note: PNDB senses output voltage to validate an "on" condition. If voltage is present at these locations prior to the PNDB "on" condition, the PNDB will not turn on.

Label 24-01665-000 -000 (P3)

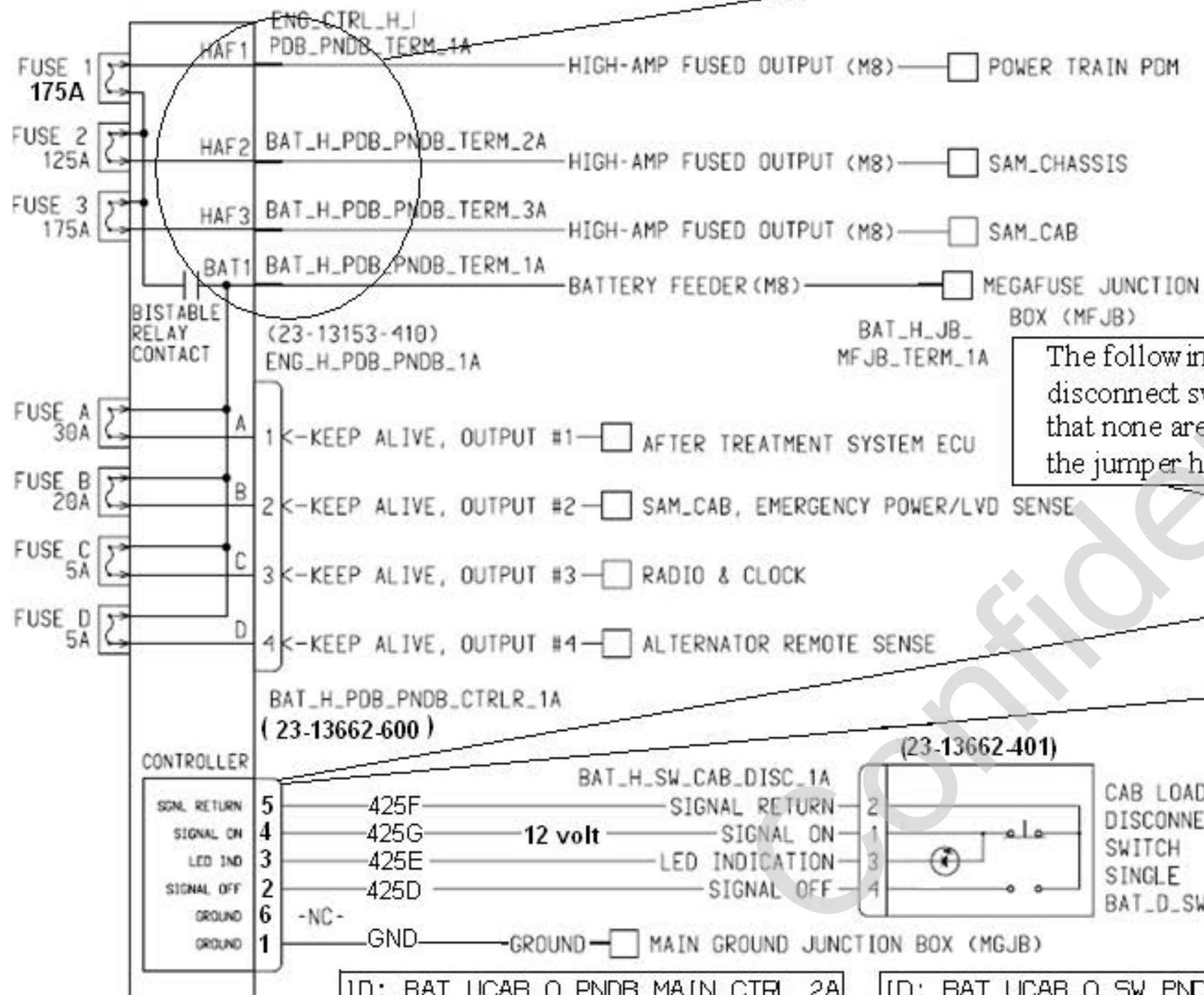

PNDB WITH C/O SW				
D	C	FUSE	AMPS	DESCRIPTION
3	A	30		AFT TREATMENT ECU
2	B	20		EMERGENCY POWER
2	C	05		RADIO AND CLOCK
1	D	05		ALT REMOTE SENSE
1	1	175		POWER TRAIN PDM
	2	125		SAM CHASSIS
	3	175		SAM CAB

The following pin out tests are used to determine if the PNDB is bad. First unplug the disconnect switch harness at both ends and validate that the wires have continuity and that none are shorted to ground, power or each other. Verify terminals are good. Reattach the jumper harness to the PNDB only and run the tests below.

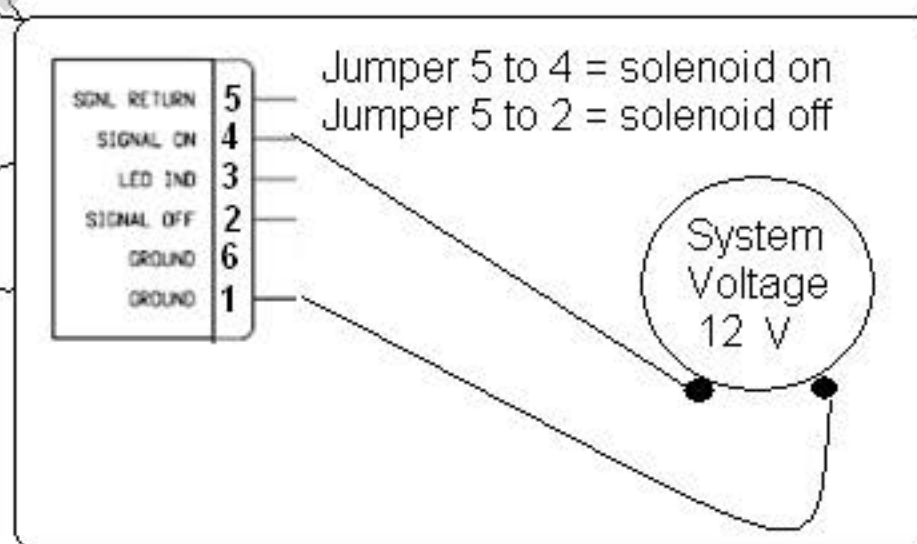

Pin out tests at PNDB

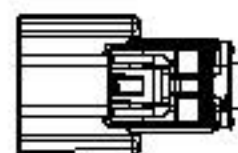
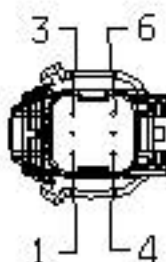

ID:	BAT_UCAB_O_PNDB_MAIN_CTRL_2A
PN:	23-13662-600
Cav	CIR #
1	GNDE
2	425D
3	425E
4	425G
5	425F

ID:	BAT_UCAB_O_SW_PNDB_1A
PN:	23-13662-401
Cav	CIR #
1	425G
2	425F
3	425E
4	425D

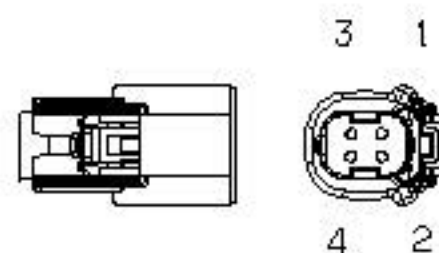

CONNECTOR END VIEW ARE SHOWN FROM THE CABLE INSERTION END

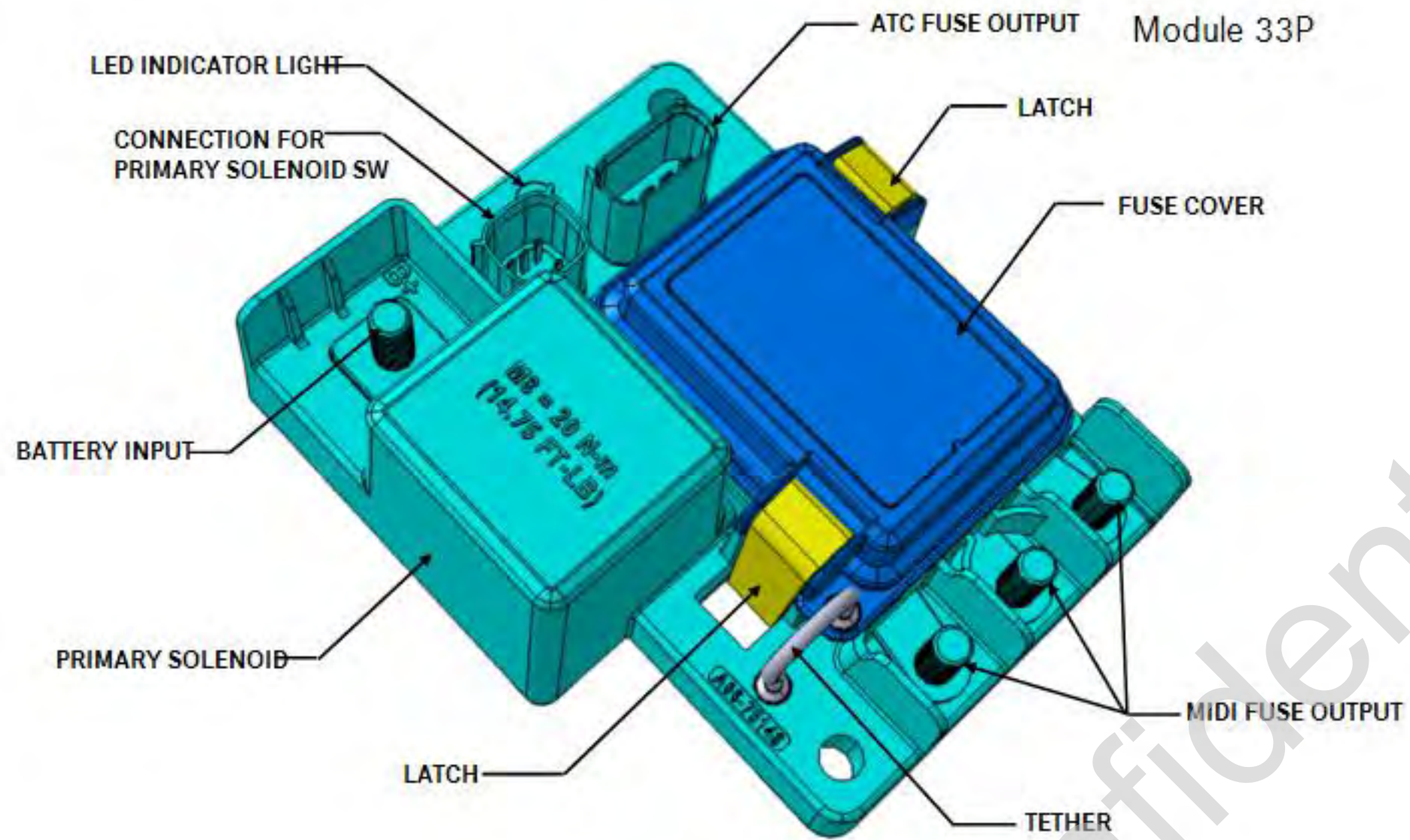

POWERNET DISTRIBUTION BOX (PNDB)
WITH SOLENOID

Confidential

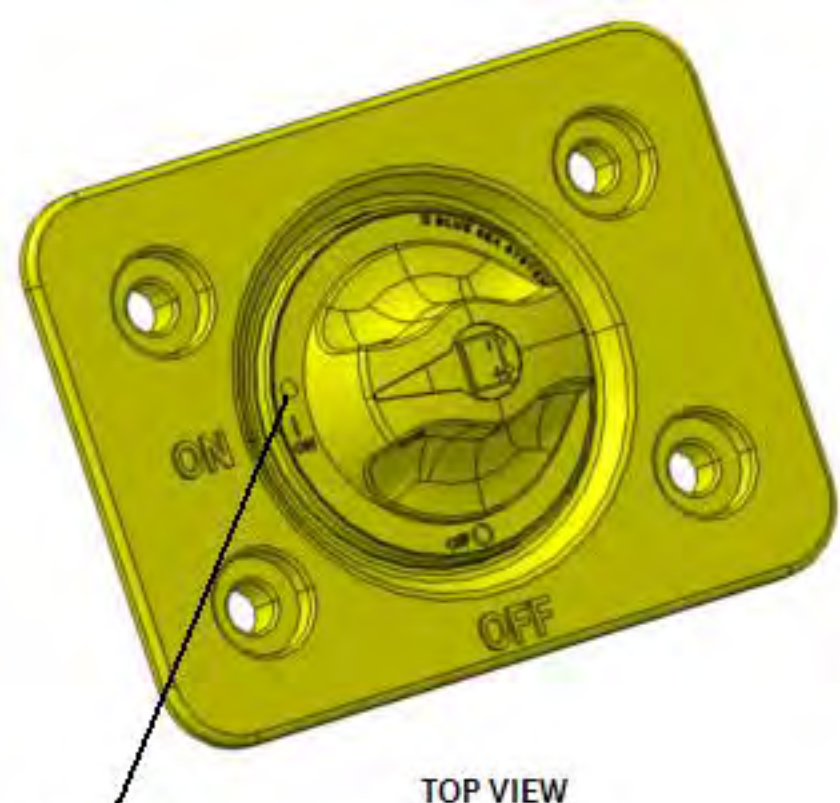

TOP VIEW

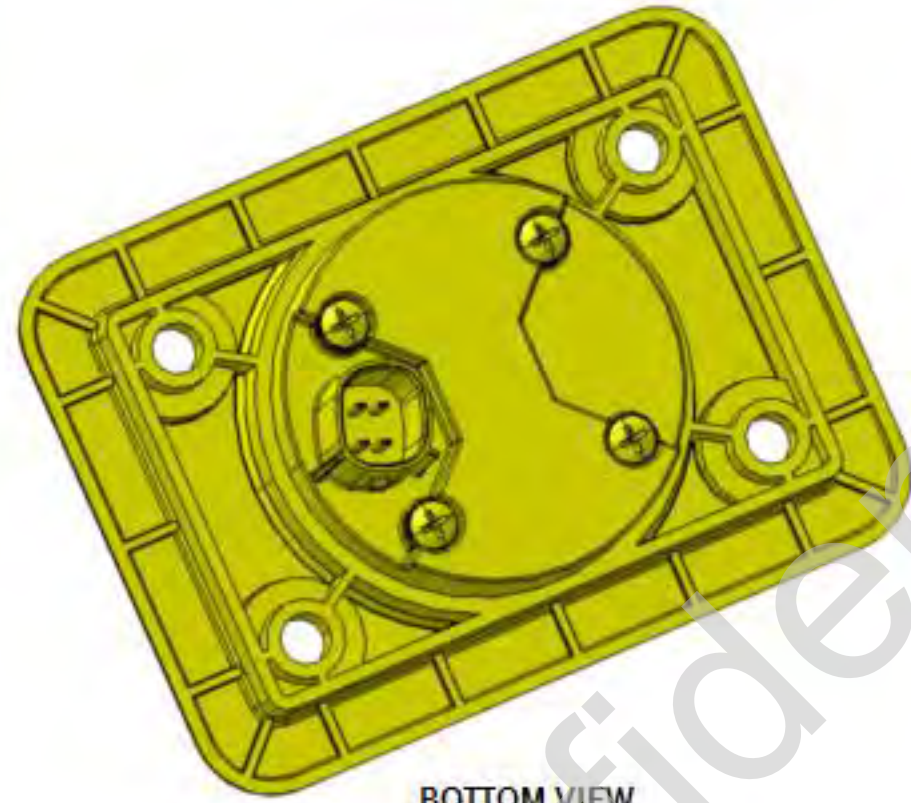

BOTTOM VIEW

PNCB CONTROL SWITCH- SINGLE
CAB MOUNTED

Confidential

Red LED