

INFORMATION REDACTED
PURSUANT TO THE FREEDOM OF
INFORMATION ACT (FOIA), 5 U.S.C.
552(B)(6)

This file represents a consolidation of multiple files sent by the manufacturer. Please use the bookmarks to navigate to each file. (Each bookmark label is the name of the original file.)



Jaguar Land Rover
Limited
Suspension Order

PRIVILEGED & CONFIDENTIAL

This notice discusses legal obligations.
It is imperative that you comply with the instructions below

Number: 2019-004

Issue: 1

Date: 7 March 2019

Title: US NHTSA Engineering Analysis EA18-004 - Doors Opening whilst driving

Model: Range Rover (L405) and Range Rover Sport (L494)

Model Year: All MY 2013 through 2017 Land Rover Range Rover and All MY 2014 through 2017 Land Rover Range Rover Sport vehicles manufactured for sale or lease in the United States and federalized territories.

Vin Range: Per Model Years above

Build Date Range: Per Model years above

Description

The Office of Defects Investigation (ODI) of the United States National Highway Traffic Safety Administration (NHTSA) opened Recall Query RQ17-005 to investigate allegations of door latch failures resulting in incidents of doors opening while driving in certain Range Rover and Range Rover Sport vehicles manufactured by Jaguar Land Rover and to request information to assist us in its investigation. Subsequently, NHTSA has progressed the investigation to an Engineering Analysis (EA) reference EA18-004.

All MY 2013 through 2017 Range Rover and all MY 2014 through 2017 Range Rover Sport vehicles equipped with Unilatch Keyless Vehicle entry systems and manufactured for sale or lease in the United States are within the scope of this EA which seeks to gather technical data and information related to the Unilatch Keyless Vehicle entry system.

Required Actions

You or your department are required to:

Retain any records that relate to the design, development (or consideration of alternative designs), testing, production, marketing or sale of the vehicle(s) and components/systems listed above.

This includes both official records and transient documents. This order suspends the normal Annual File Review / JLR-RMP (Jaguar Land Rover's Records Management Procedure) retention periods together with the Records Retention Schedule (All Markets) retention periods.

If you do not understand your obligation or have any questions regarding whether this applies to records you create or manage, please contact Gemma Furlong (gfurlon2).

Definition of Records

Records include but are not limited to:

- Reports (Including drafts)
- Correspondence
- Memoranda (Including drafts)
- Meeting minutes (Including drafts)
- Faxes
- E-mails, including those sent, received or in draft form if retained.
- Computer-aided engineering drawings or simulations
- Engineering drawings
- Change Requests
- Brochures, Factsheets and other Advertising Materials
- Sales information
- Process or assembly instructions
- Any audio or video recordings
- Field Service Action (FSA) approval documents, requests for FSA's
- Service Communications
- Quality Investigation information of any form
- Warranty, Field or supplier data in JLR's possession

NHTSA define:-

Document; "Document(s)" is used in the broadest sense of the word and shall mean all original written, printed, typed, recorded, or graphic matter whatsoever, however produced or reproduced, of every kind, nature, and description, and all non-identical copies of both sides thereof, including, but not limited to, papers, letters, memoranda, correspondence communications, electronic mail (e-mail) messages (existing in hard copy and/or in electronic storage), faxes, mailgrams, telegrams, cables, telex messages, notes, annotations, working papers, drafts, minutes, records, audio and video recordings, data, databases, other information bases, summaries, charts, tables, graphics, other visual displays, photographs, statements, interviews, opinions, reports, newspaper articles, studies, analyses, evaluations, interpretations, contracts, agreements, jottings, agendas, bulletin, notices, announcements, instructions, blueprints, drawings, as-built, changes, manuals, publications, work schedules, journals, statistical data, desk, portable and computer calendars, appointment books, diaries, travel reports, lists, tabulations, computer printouts, data processing program libraries, data processing inputs and outputs, microfilms, microfiches, statements for services, resolutions, financial statements, governmental records, business records, personnel records, work orders, pleadings, discovery in any form, affidavits, motions, responses to discovery, all transcripts, administrative filings and all mechanical, magnetic, photographic and electronic records or recordings of any kind,

including any storage media associated with computers, including, but not limited to, information on hard drives, floppy disks, backup tapes, and zip drives, electronic communications, including but not limited to, the Internet and shall include any drafts or revisions pertaining to any of the foregoing, all other things similar to any of the foregoing, however denominated by JLR, any other data compilations from which information can be obtained, translated if necessary, into a usable form and any other documents. For purposes of this request, any document which contains any note, comment, addition, deletion, insertion, annotation, or otherwise comprises a non-identical copy of another document shall be treated as a separate document subject to production. In all cases where original and any non-identical copies are not available, "document(s)" also means any identical copies of the original and all non-identical copies thereof. Any document, record, graph, chart, film or photograph originally produced in color must be provided in color. Furnish all documents whether verified by JLR or not. If a document is not in the English language, provide both the original document and an English translation of the document.

Other Terms: To the extent that they are used in these information requests, the terms "claim," "consumer complaint," "dealer field report," "field report," "fire," "fleet," "good will," "make," "model," "model year," "notice," "property damage," "property damage claim," "rollover," "type," "warranty," "warranty adjustment," and "warranty claim," whether used in singular or in plural form, have the same meaning as found in 49 CFR 579.4.

In addition to other steps you take to preserve records, you must take action to prevent the automatic deletion of electronic records.

You must preserve electronic records in native file format. The native file format is the default file format used by a specific software application (e.g. ".doc" for Microsoft Word files and ".xls" for Microsoft Excel files).

Any documents with shared network folders are also suspended.

In the case of individuals within a team each having a copy of the same document or email, each copy should be considered a separate document and retained.

Documents kept in both print and electronic format are also considered separate records.

If you are unsure whether information you hold may constitute a record, please contact Chris Scott (cscott3).

Suspension Orders are privileged and confidential and, as such, dissemination should be limited to persons working at Jaguar Land Rover Limited on a need-to-know basis. Suspension Orders should not be shared with suppliers, outside consultants, or others outside the company.

31 MAY 2013

© Jaguar Land Rover North America, LLC

NOTE: The information in Technical Bulletins is intended for use by trained, professional Technicians with the knowledge, tools, and equipment required to do the job properly and safely. It informs these Technicians of conditions that may occur on some vehicles, or provides information that could assist in proper vehicle service. The procedures should not be performed by 'do-it-yourselfers'. If you are not a Retailer, do not assume that a condition described affects your vehicle. Contact an authorized Land Rover service facility to determine whether this bulletin applies to a specific vehicle.

SECTION: 501-14

Soft Door Close Lock Functionality

AFFECTED VEHICLE RANGE:

Range Rover (LG)

Model Year:

2013

VIN:

DA100000-DA111289

MARKETS:

NAS

CONDITION SUMMARY:

Situation: The soft door close function may operate intermittently or will not fully close.

Cause:

This may be caused by the soft door close mechanism spring becoming dislocated.

Action:

In the event of a customer concern of the above, refer to the Service Instruction outlined below.

WARRANTY:

△ **NOTE:** Repair procedures are under constant review, and therefore times are subject to change; those quoted here must be taken as guidance only. Always refer to TOPIx to obtain the latest repair time.

△ **NOTE:** The JLR Claims Submission System requires the use of causal part numbers. Labor only claims must show the causal part number with a quantity of zero.

DESCRIPTION	SRO	TIME (HOURS)	CONDITION CODE	CAUSAL PART
Re-locate door latch spring - front - one side	76.37.89/53	1.00	42	LR048252
Re-locate door latch spring - front - both sides	76.37.89/54	2.00	42	LR048252
Re-locate door latch spring - rear - one side	76.37.89/55	0.80	42	LR048252
Re-locate door latch spring - rear - both sides	76.37.89/56	1.50	42	LR048252
Adjust 1 or 2 door(s) on striker(s)	05.10.10	0.10	42	LR048252
Adjust 3 or 4 doors on striker(s)	05.10.20	0.20	42	LR048252

△ **NOTE:** Normal Warranty procedures apply.

SERVICE INSTRUCTION:

1.  **WARNING: The door latch mechanism may move automatically; DO NOT insert fingers in to the door latch mechanism.**

△ **NOTE:** Front right door latch shown; others similar.

Check the operation of the door latch:

- Open the door.
- Using a suitable tool, carefully move the door latch from position 1 to position 2.
- The latch should automatically move from position 2 to position 3 due to the soft door close function.
 - If the latch operates correctly in all three positions, carry on to step 2.
 - If the soft door close function moves the door latch to position 3, wait for two (2) seconds. Operate the internal or external door handle and observe the door latch movement. If the door latch is slow to return to position 1 or if it stops at position 2 and then returns to position 3, carry out steps 4-6.
- If the door latch does not automatically move to position 3 **AND** cannot be manually moved to position 3, carry out steps 4-6.

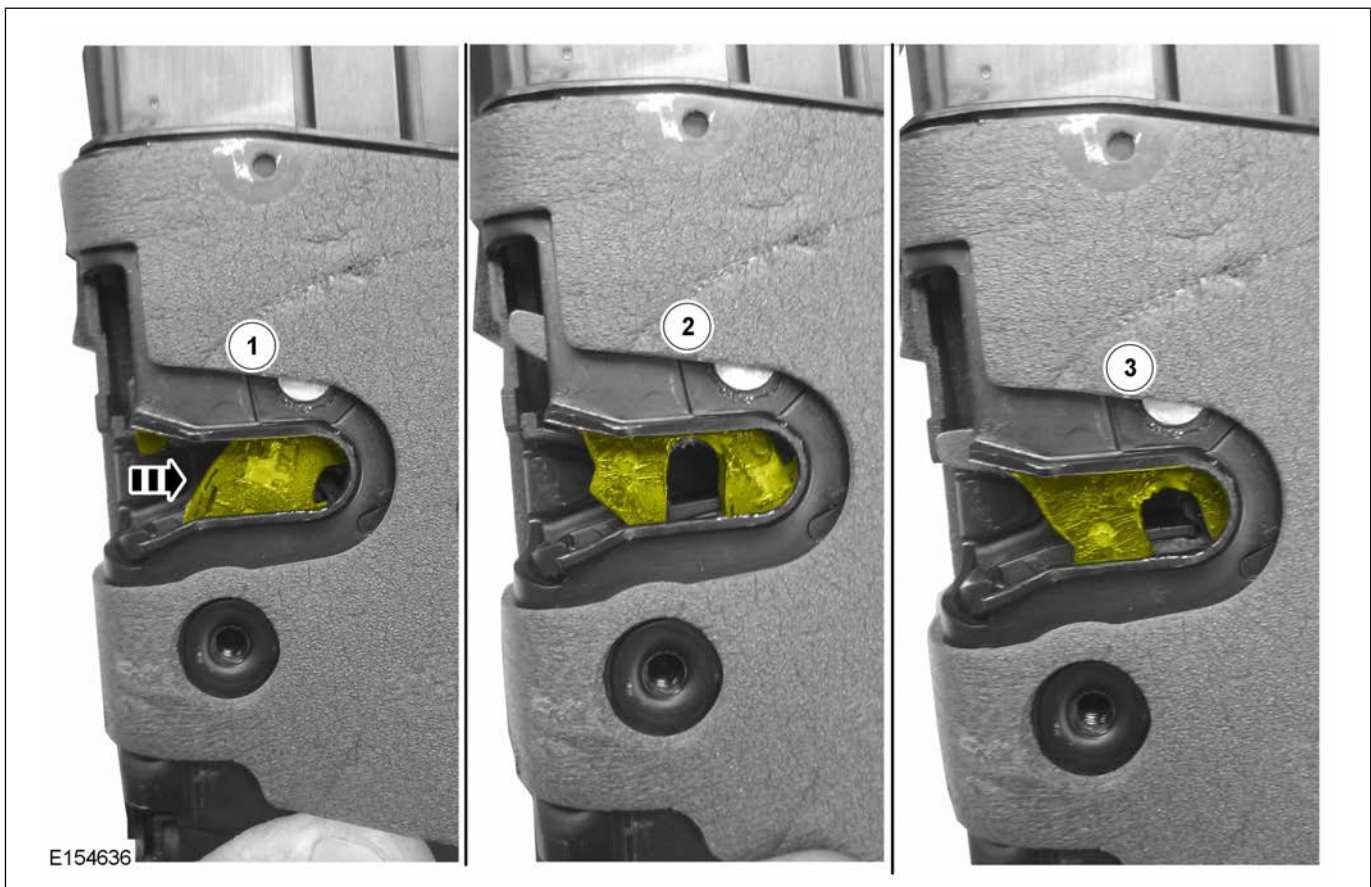

2. △ NOTE: Front left shown; others similar.

△ NOTE: Make sure that the door is pulled at the 'ticked' position shown. Do not pull on the door handle as this will cause the door to unlatch / open.

If the soft door close function is still intermittent, close the door and instigate the error state.

- Once the door is in the error state with the soft door close not pulling the door in, gently pull the door away from the vehicle body side by carefully pulling on the key cover.
- If the soft door close function then initiates and pulls the door onto the primary latch position, adjust the striker for the door inboard by 1mm (see step 3).

- Retest soft door close function, and make sure that panel flushness has not been affected by the adjustment.

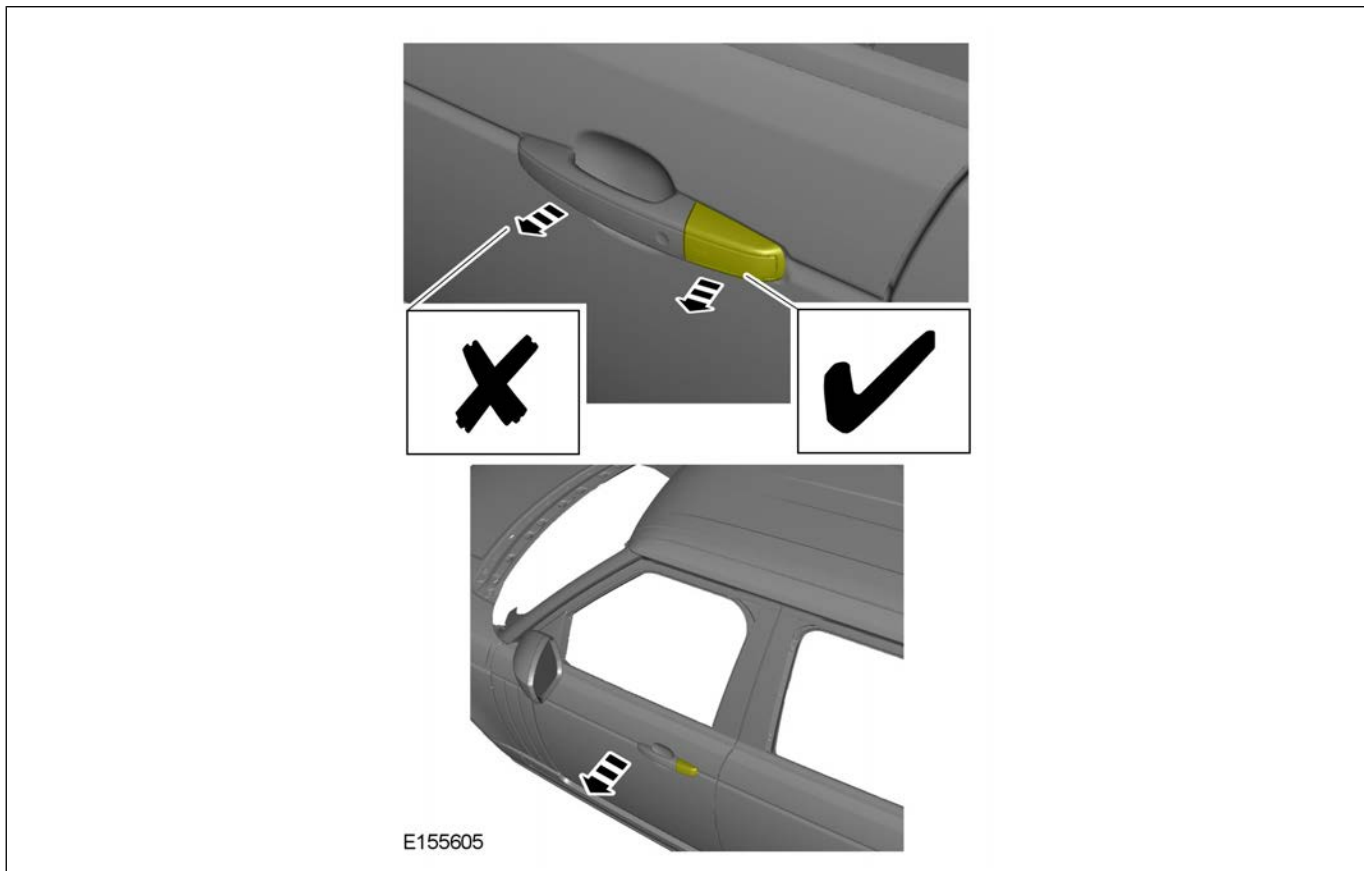

3. Adjust the affected door striker:

- To aid in identifying striker movement, apply suitable non-marking tape to the B- / C-pillar at the outer edge of the striker.
- Slacken the two (2) Torx bolts.
- Using a soft-faced mallet, re-position the striker inwards by 1mm.
- Tighten the two (2) Torx bolts to 25Nm.

- Remove the tape.



△ NOTE: Only carry out the steps below if a fault has been diagnosed in step 1.

4. Remove the affected door latch (see TOPIx Workshop Manual section 501-14: Handles, Locks, Latches and Entry Systems).
5. ⚠ CAUTION: Make sure that the spring is fully located in to the plastic recess.

Using a suitable tool, relocate the spring in to the recess as shown.

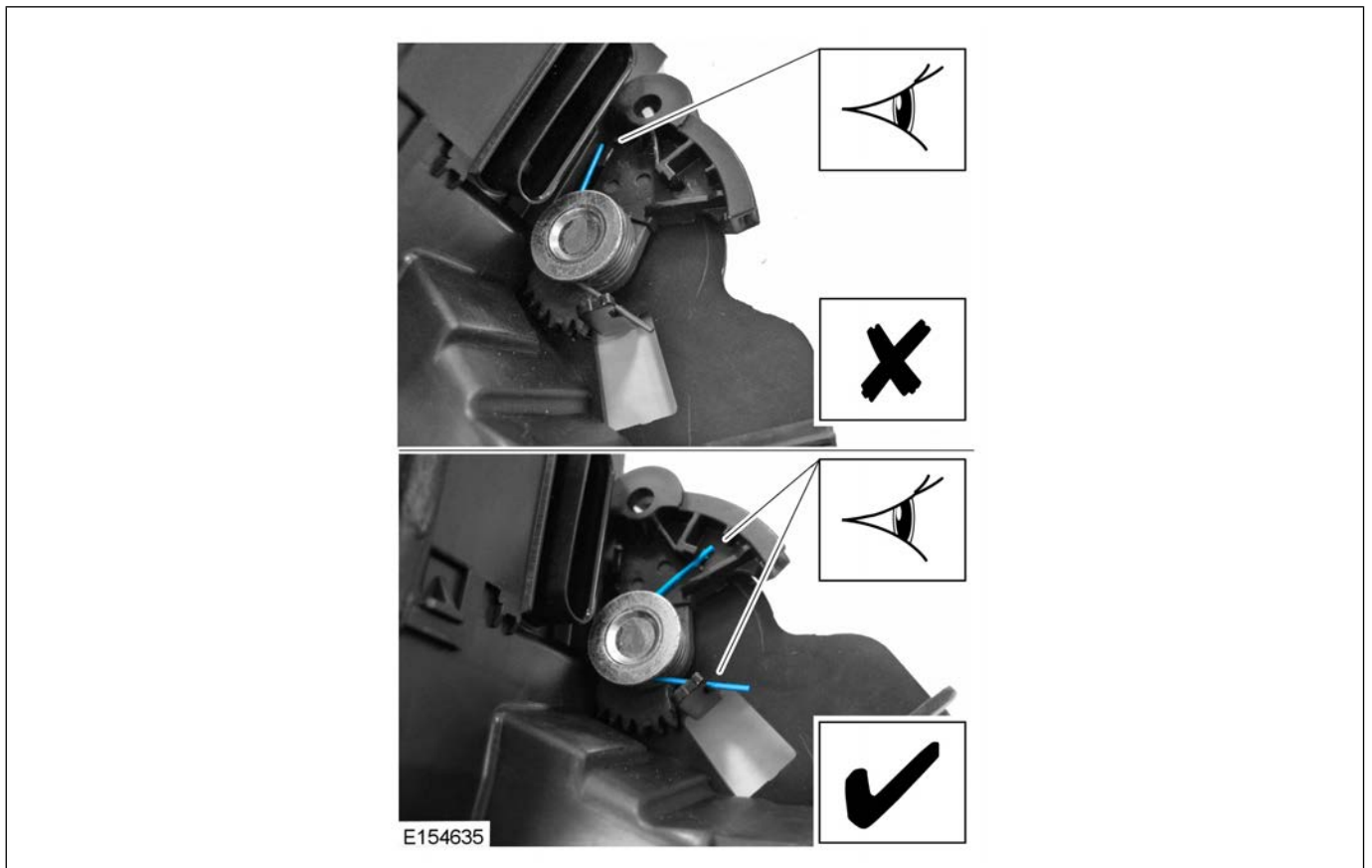

6. Install the door latch (see TOPlx Workshop Manual section 501-14: Handles, Locks, Latches and Entry Systems).



© Jaguar Land Rover North America, LLC

NOTE: The information in Technical Bulletins is intended for use by trained, professional Technicians with the knowledge, tools, and equipment required to do the job properly and safely. It informs these Technicians of conditions that may occur on some vehicles, or provides information that could assist in proper vehicle service. The procedures should not be performed by 'do-it-yourselfers'. If you are not a Retailer, do not assume that a condition described affects your vehicle. Contact an authorized Land Rover service facility to determine whether this bulletin applies to a specific vehicle.

This reissue replaces all previous versions. Please destroy all previous versions.

SECTION: 501-14

Soft Door Close Lock Functionality

AFFECTED VEHICLE RANGE:

Range Rover (LG)

Model Year: 2013 Onwards

VIN: DA001204 Onwards

MARKETS:

NAS

CONDITION SUMMARY:

Situation:

△ NOTE: [Change to end VIN and Model Year applicability only.](#)

The soft door close function may operate intermittently or will not fully close.

Cause:

This may be caused by the soft door close mechanism spring becoming dislocated.

Action:

Should a customer express this concern, refer to the Service Instruction outlined below.

WARRANTY:

△ NOTE: Repair procedures are under constant review, and therefore times are subject to change; those quoted here must be taken as guidance only. Always refer to TOPIx to obtain the latest repair time.

△ NOTE: The JLR Claims Submission System requires the use of causal part numbers. Labor only claims must show the causal part number with a quantity of zero.

DESCRIPTION	SRO	TIME (HOURS)	CONDITION CODE	CAUSAL PART
Re-locate door latch spring - front - one side	76.37.89/53	1.00	42	LR048252
Re-locate door latch spring - front - both sides	76.37.89/54	2.00	42	LR048252
Re-locate door latch spring - rear - one side	76.37.89/55	0.90	42	LR048252
Re-locate door latch spring - rear - both sides	76.37.89/56	1.70	42	LR048252
Adjust 1 or 2 door(s) on striker(s)	05.10.10	0.10	42	LR048252
Adjust 3 or 4 doors on striker(s)	05.10.20	0.20	42	LR048252

△ NOTE: Normal Warranty procedures apply.

SERVICE INSTRUCTION:

1. **▲ WARNING:** The door latch mechanism may move automatically; **DO NOT** insert fingers into the door latch mechanism.

△ **NOTE:** Front right door latch shown; others similar.

Check the operation of the door latch:

- Open the door.
- Using a suitable tool, carefully move the door latch from position 1 to position 2.
- The latch should automatically move from position 2 to position 3 due to the soft door close function.
- If the latch operates correctly in all three positions, carry on to step 2.
- If the soft door close function moves the door latch to position 3, wait for two (2) seconds. Operate the internal or external door handle and observe the door latch movement. If the door latch is slow to return to position 1 or if it stops at position 2 and then returns to position 3, carry out steps 4-6.
- If the door latch does not automatically move to position 3 **AND** cannot be manually moved to position 3, carry out steps 4-6.

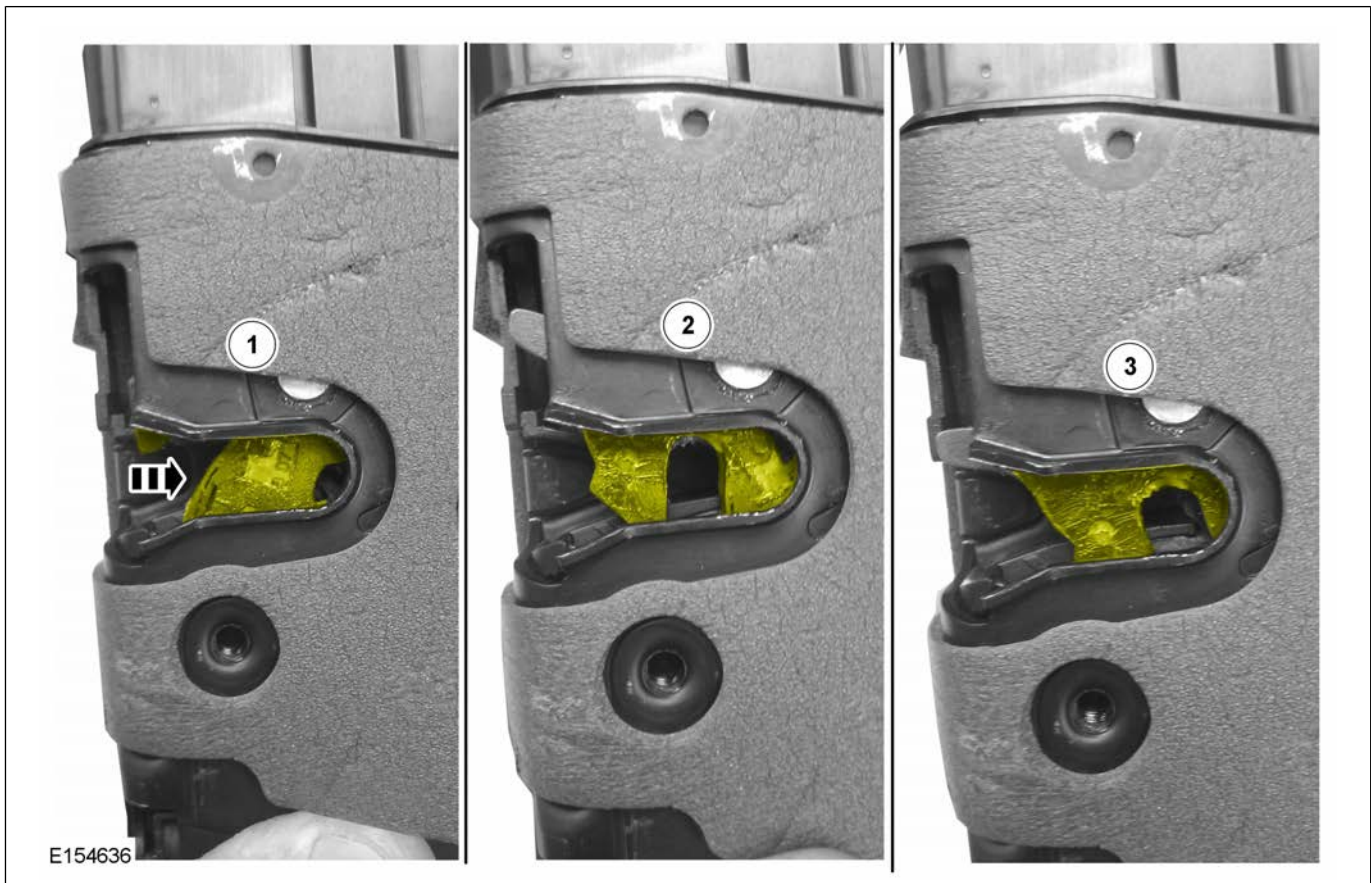

2. △ **NOTE:** Front left shown; others similar.

△ **NOTE:** Make sure that the door is pulled at the 'ticked' position shown. Do not pull on the door handle as this will cause the door to unlatch / open.

If the soft door close function is still intermittent, close the door and instigate the error state.

- Once the door is in the error state with the soft door close not pulling the door in, gently pull the door away from the vehicle body side by carefully pulling on the key cover.
- If the soft door close function then initiates and pulls the door onto the primary latch position, adjust the striker for the door inboard by 1mm (see step 3).
- Retest soft door close function, and make sure that panel flushness has not been affected by the adjustment.

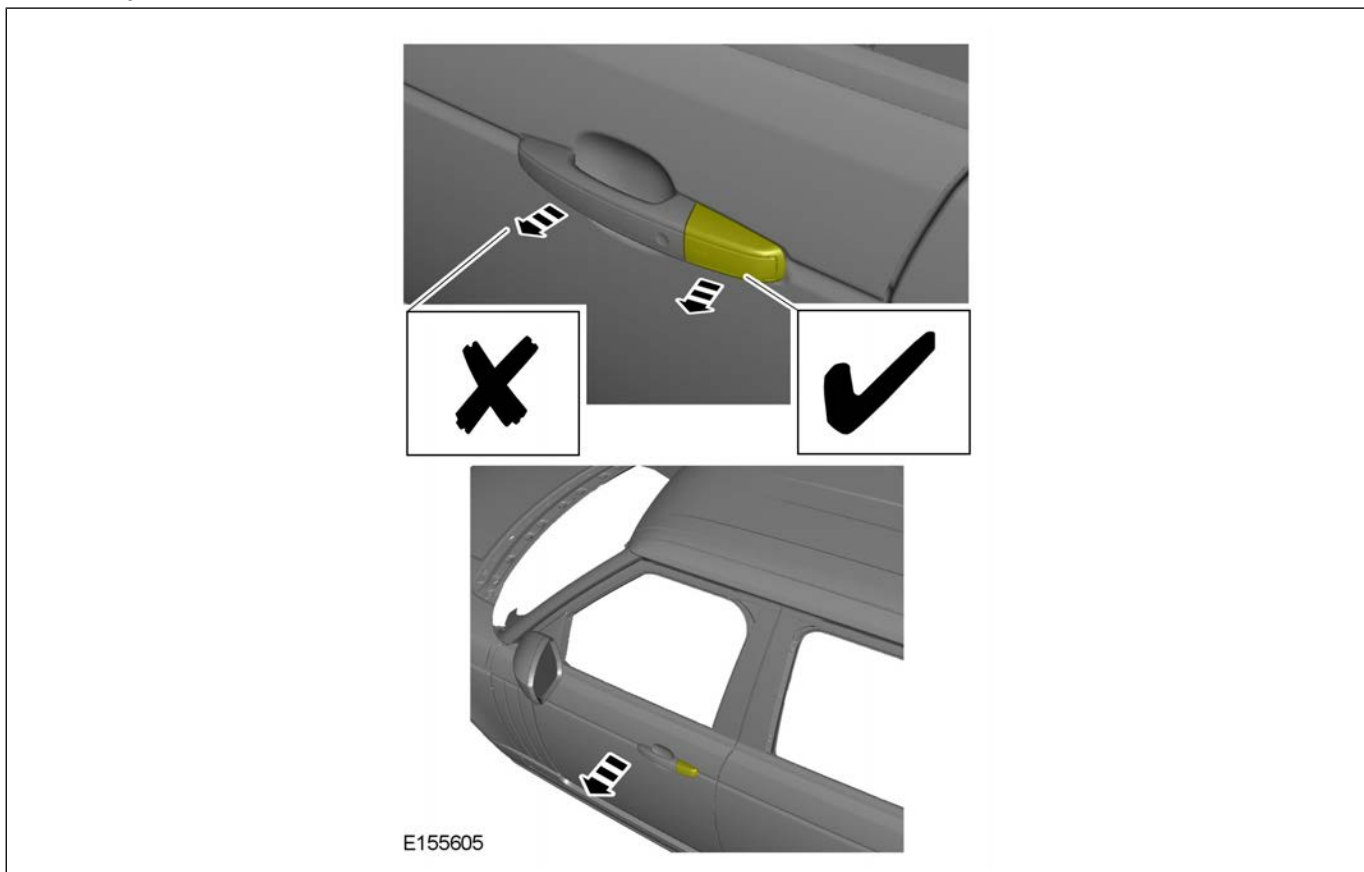

3. Adjust the affected door striker:

- To aid in identifying striker movement, apply suitable non-marking tape to the B- / C-pillar at the outer edge of the striker.
- Slacken the two (2) Torx bolts.
- Using a soft-faced mallet, re-position the striker inwards by 1mm.
- Tighten the two (2) Torx bolts to 25Nm.

- Remove the tape.



△ **NOTE:** Only carry out the steps below if a fault has been diagnosed in step 1.

4. Remove the affected door latch (see TOPIx Workshop Manual section 501-14: Handles, Locks, Latches and Entry Systems).
5. ⚠ **CAUTION:** Make sure that the spring is fully located in to the plastic recess.

Using a suitable tool, relocate the spring in to the recess as shown.

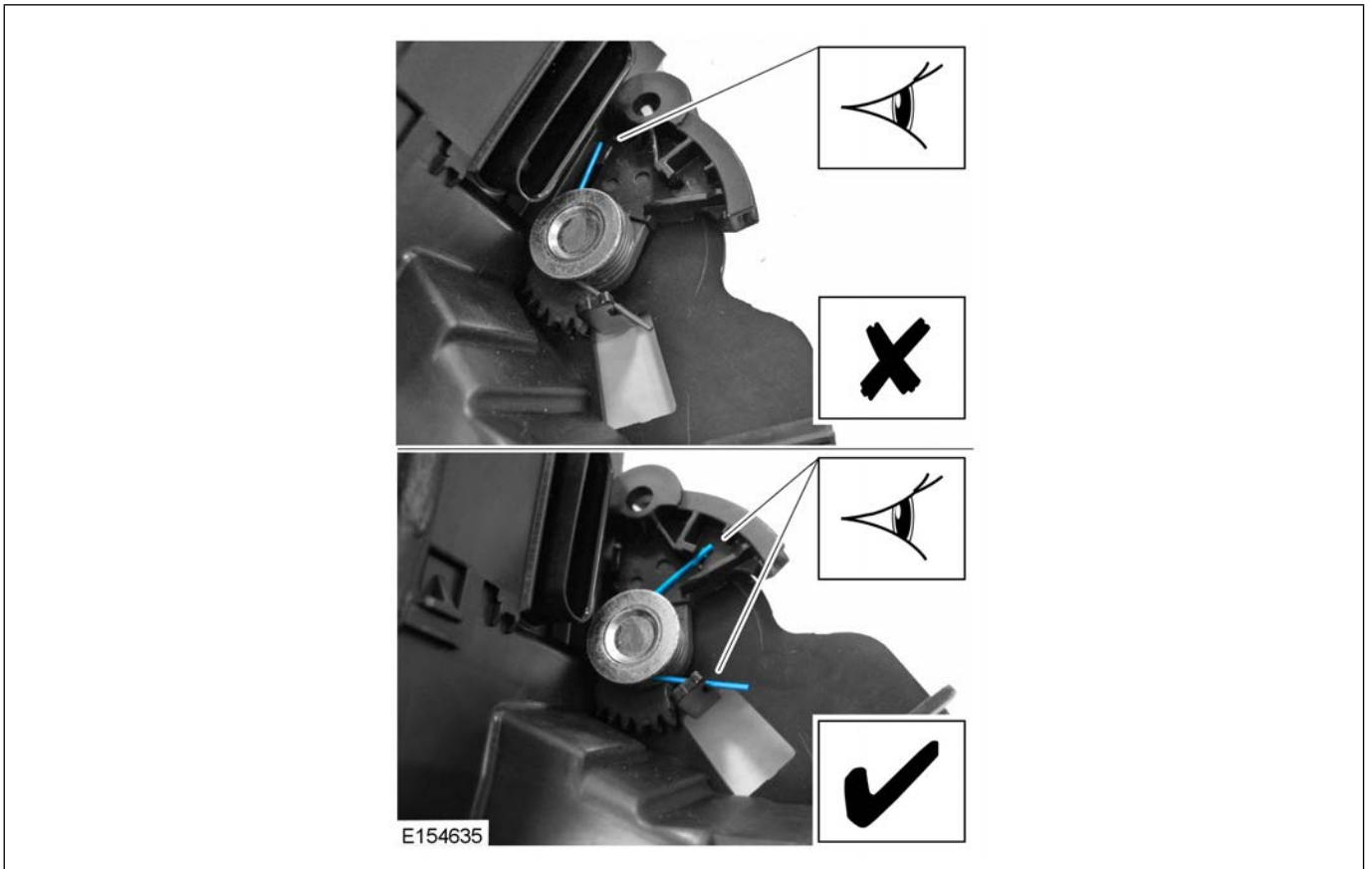

6. Install the door latch (see TOPlx Workshop Manual section 501-14: Handles, Locks, Latches and Entry Systems).



© Jaguar Land Rover North America, LLC

NOTE: The information in Technical Bulletins is intended for use by trained, professional Technicians with the knowledge, tools, and equipment required to do the job properly and safely. It informs these Technicians of conditions that may occur on some vehicles, or provides information that could assist in proper vehicle service. The procedures should not be performed by 'do-it-yourselfers'. If you are not a Retailer, do not assume that a condition described affects your vehicle. Contact an authorized Land Rover service facility to determine whether this bulletin applies to a specific vehicle.

SECTION: 501-14

Compact Key Handset - Lower-Level Service Repair

AFFECTED VEHICLE RANGE:

LR2 (LF)

Model Year:2013-2014

VIN: DH303399-EH385500

LR4 (LA)

Model Year:2012-2013

VIN: CA582668-DA700486

Range Rover Evoque (LV)

Model Year:2012-2014

VIN: CH000447-EH862000

Range Rover Sport (LW)

Model Year:2014

VIN: EA000002-EA328222

Range Rover (LG)

Model Year:2013-2014

VIN: DA000083-EA145851

Range Rover Sport (LS)

Model Year:2012-2013

VIN: CA299939-DA814146

MARKETS:

NAS

CONDITION SUMMARY:

Situation: The face of the compact key handset may peel away from the handset main body or the handset case may be bulging.

Cause: This may be caused by the handset manufacturing process.

△ NOTE: A small quantity of Range Rover Evoque, Range Rover Sport, and Range Rover vehicles may have been manufactured gloss-finish compact key handsets. These handsets are no longer available. Should a Range Rover Evoque, Range Rover Sport, and Range Rover customer complain one of their gloss-finish handsets having the above concern, it is recommended to service the customer's remaining gloss-finish handsets as per the Service Instruction outlined below. Contact the customer prior to the repair and request the remaining gloss-finish handsets be present for their Service appointment. All customer handsets should match after the conclusion of the repair. LR2 and LR4 vehicles currently fitted with matte finish handsets should have only the faulty handset(s) repaired.

Action: Should the customer express this concern, follow the Service Instruction outlined below.

PARTS:

△ NOTE: One (1) kit required per handset.

LR059382	Compact key kit - LR2, LR4	1
LR059384	Compact key kit - Range Rover Evoque, Range Rover Sport, Range Rover	1

WARRANTY:

△ NOTE: SRO time covers one (1) handset (may be used per handset repaired when applicable).

△ NOTE: Repair procedures are under constant review, and therefore times are subject to change; those quoted here must be taken as guidance only. Always refer to TOPIx to obtain the latest repair time.

△ NOTE: The JLR Claims Submission System requires the use of causal part numbers. Labor only claims must show the causal part number with a quantity of zero.

DESCRIPTION	SRO	TIME (HOURS)	CONDITION CODE	CAUSAL PART
Casing - 'Land Rover' embossed - Handset/Compact key - One - Renew - LR2, LR4	86 77 36	0.1	49	LR029695
Casing - Handset/Compact key - Renew - One - Range Rover Evoque, Range Rover Sport, Range Rover	86 77 36	0.1	49	LR027451

△ NOTE: Normal Warranty procedures apply.

SERVICE INSTRUCTION:

Step 1: Range Rover Evoque, Range Rover Sport, and Range Rover vehicles only.

1. Identify the type of compact key handset currently fitted to the vehicle:

- Left = matte finish; continue to step 2.
- Right = gloss finish; a small quantity of Range Rover Evoque, Range Rover Sport, and Range Rover vehicles may have been manufactured gloss-finish compact key handsets. These handsets are no longer available. Should a Range Rover Evoque, Range Rover Sport, and Range Rover customer complain one of their gloss-finish handsets having the above concern, it is recommended to service the customer's remaining gloss-finish handsets as per the Service Instruction outlined below. Contact the customer prior to the repair and request the remaining gloss-finish handsets be present for their Service appointment. All customer handsets should match after the conclusion of the repair. Continue to step 2.



△ NOTE: Please refer to SSM70798, 'Compact key low level repair - animation of process', to view the animation file.

2. Remove the chrome cap; place to one side.

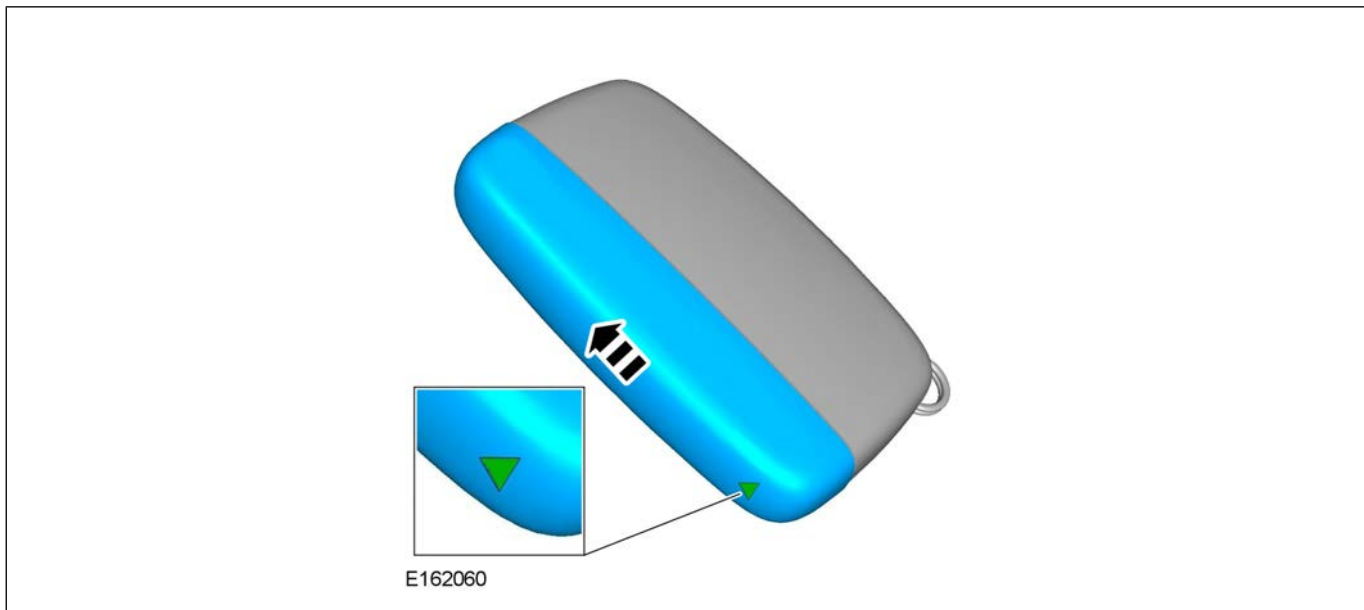

3. Remove the key blade.



4. Using the key blade, remove and discard the lower case.

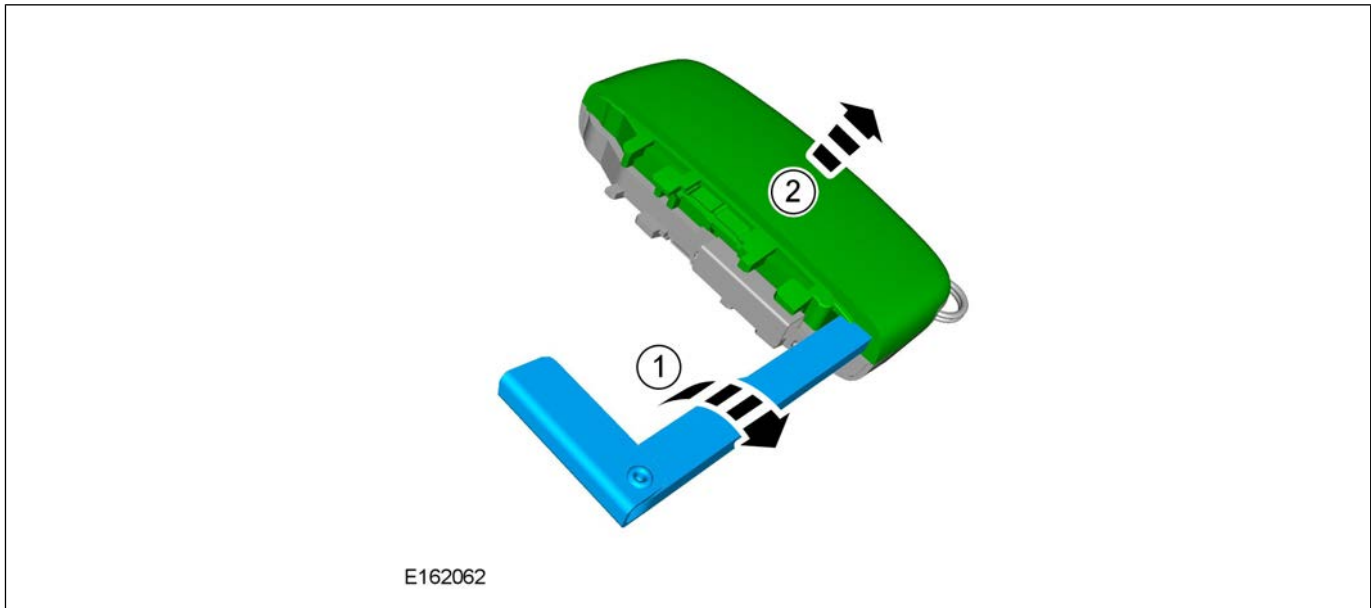

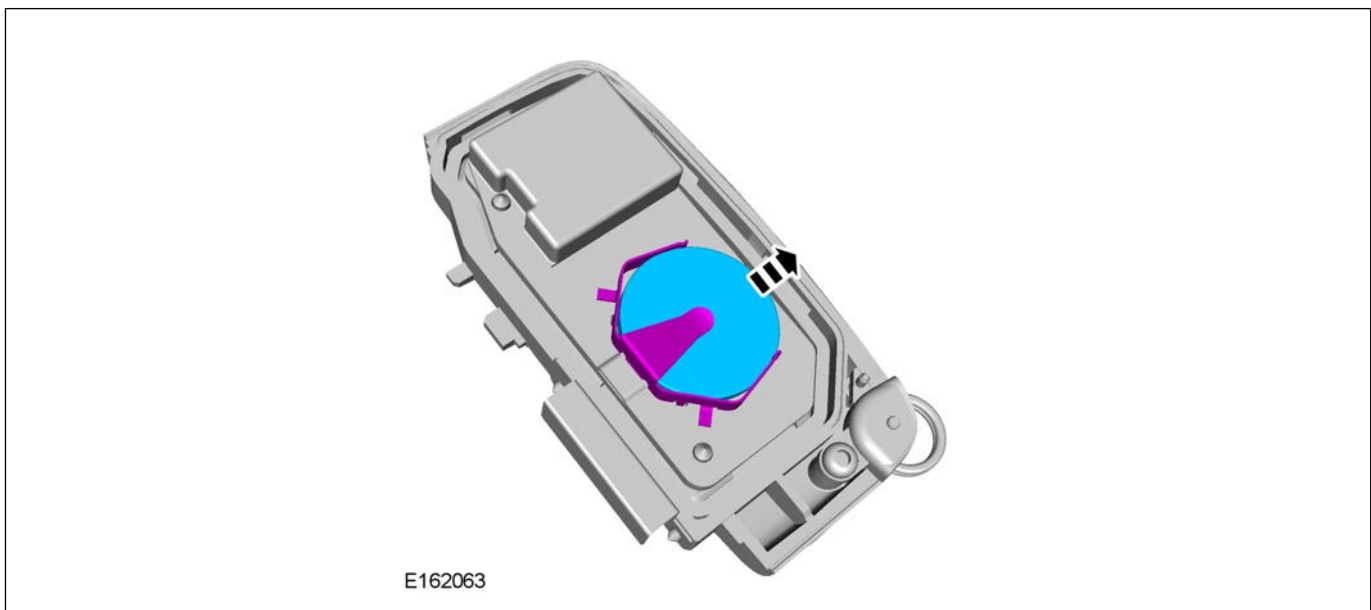

5. Remove the battery from the upper case.

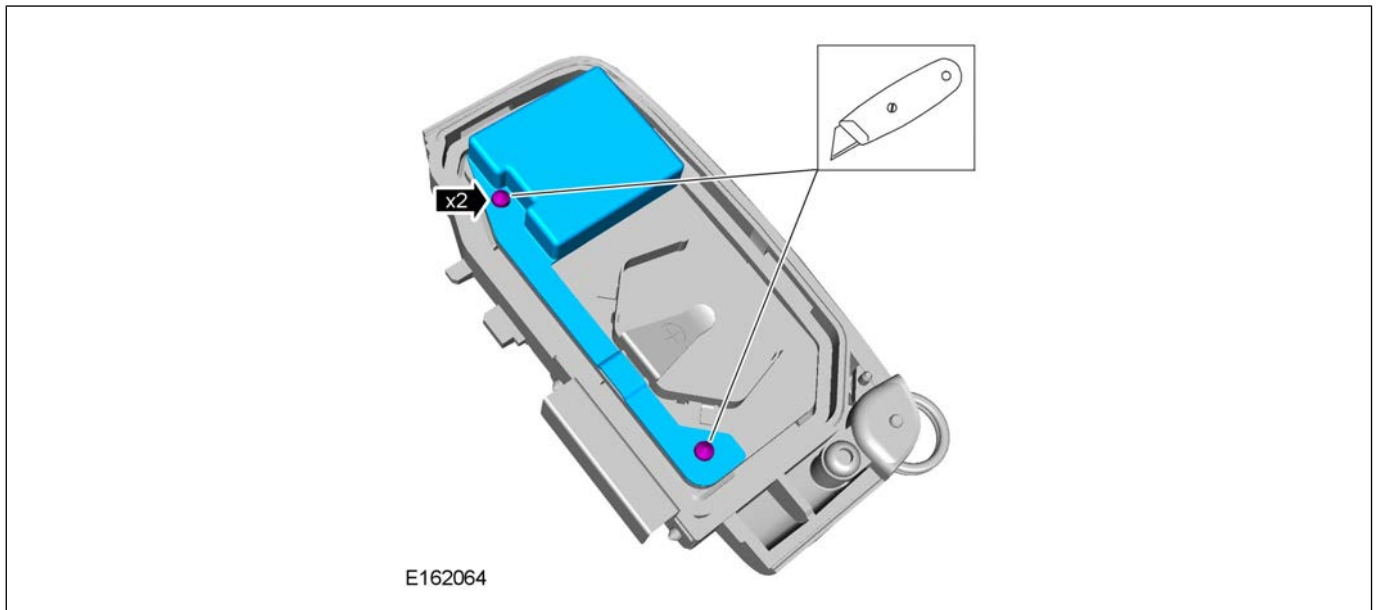

6.  CAUTION: Make sure the Printed Circuit Board (PCB) is not damaged when removing the black anti-tamper cover. If the copper coil antenna is damaged, the unit will be unserviceable.

Using a suitable tool, cut the fixings of the black anti-tamper cover and lift away from the Printed Circuit Board (PCB).



7.  CAUTION: When removing the PCB, only handle the outer edges of the board.
Remove the PCB; place to one side.

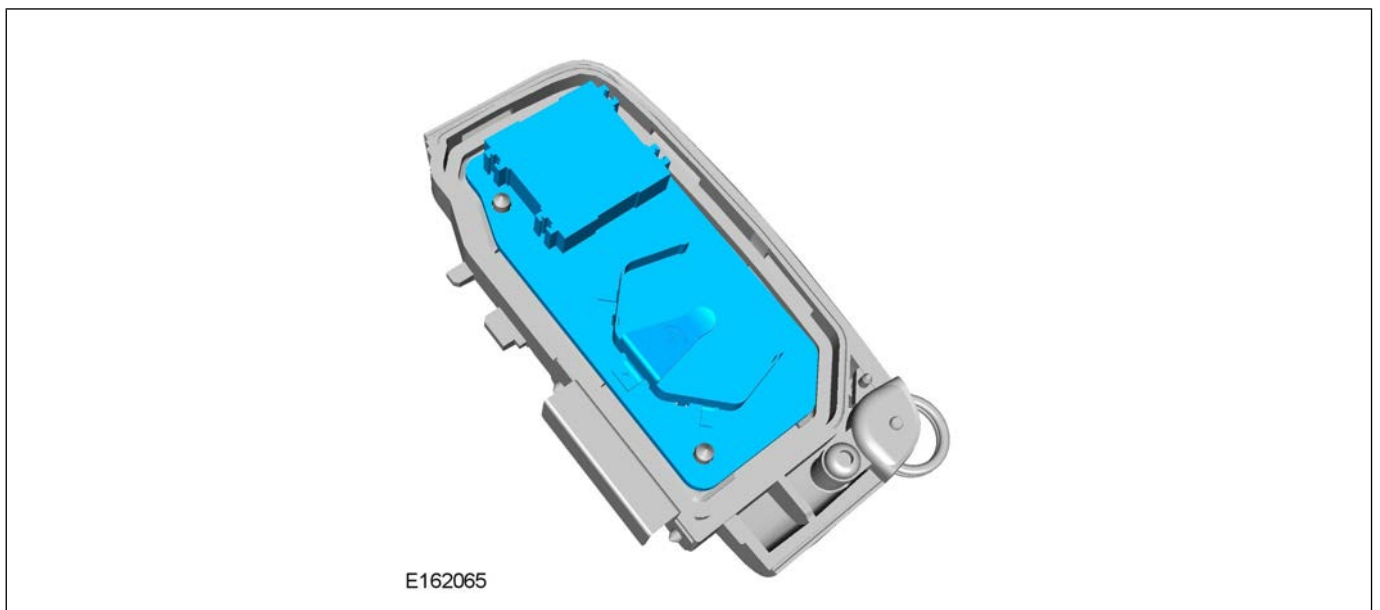

8. Remove the key ring retainer; place to one side.

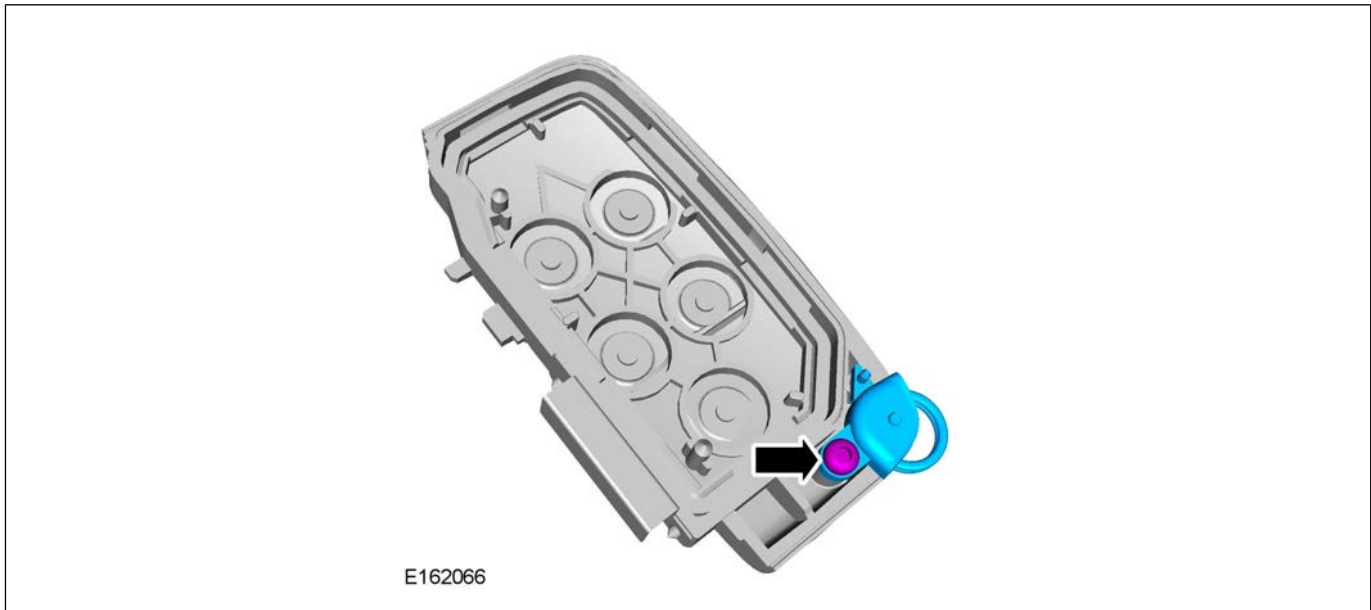

9. Remove the silicone seal from the lower case; place to one side.

- Discard the upper case.
-



10. Make sure the foam pads are installed in the lower case as shown.

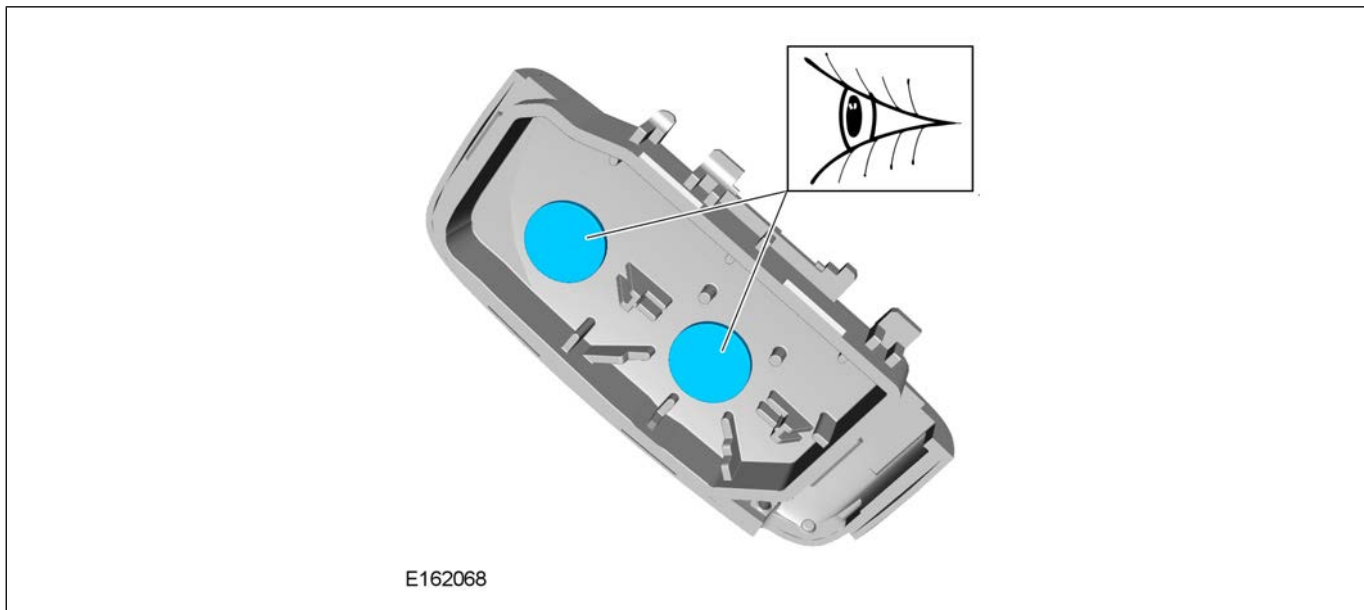

11. Install the silicone seal to the upper case.

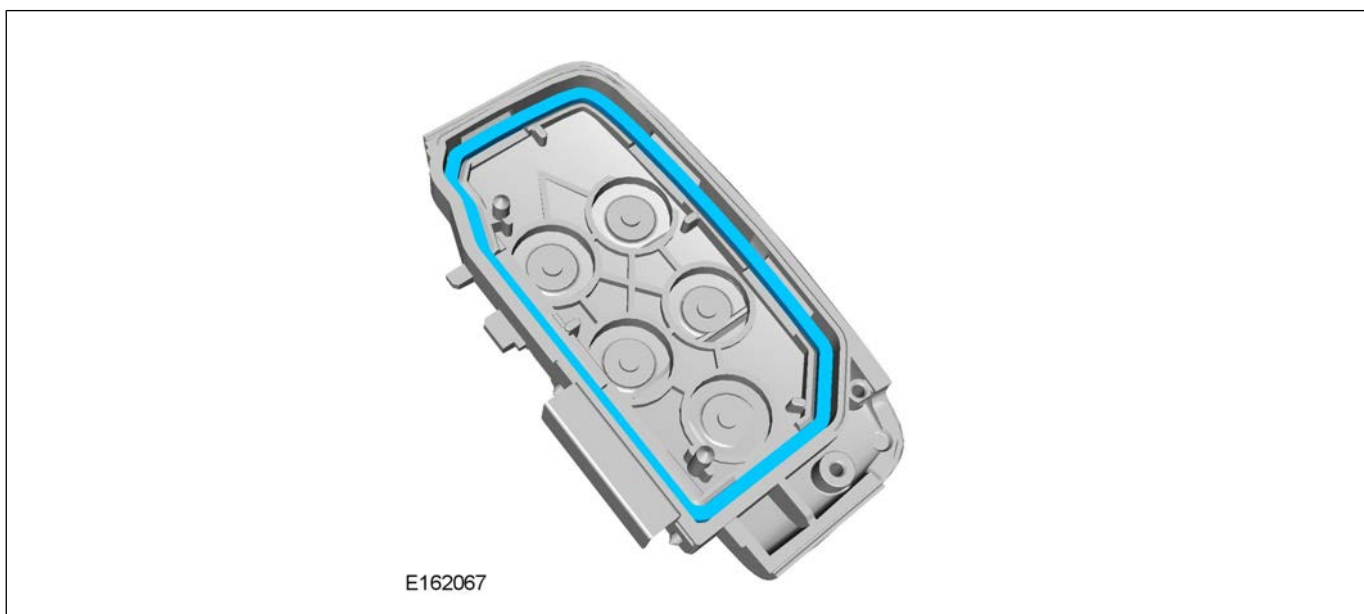

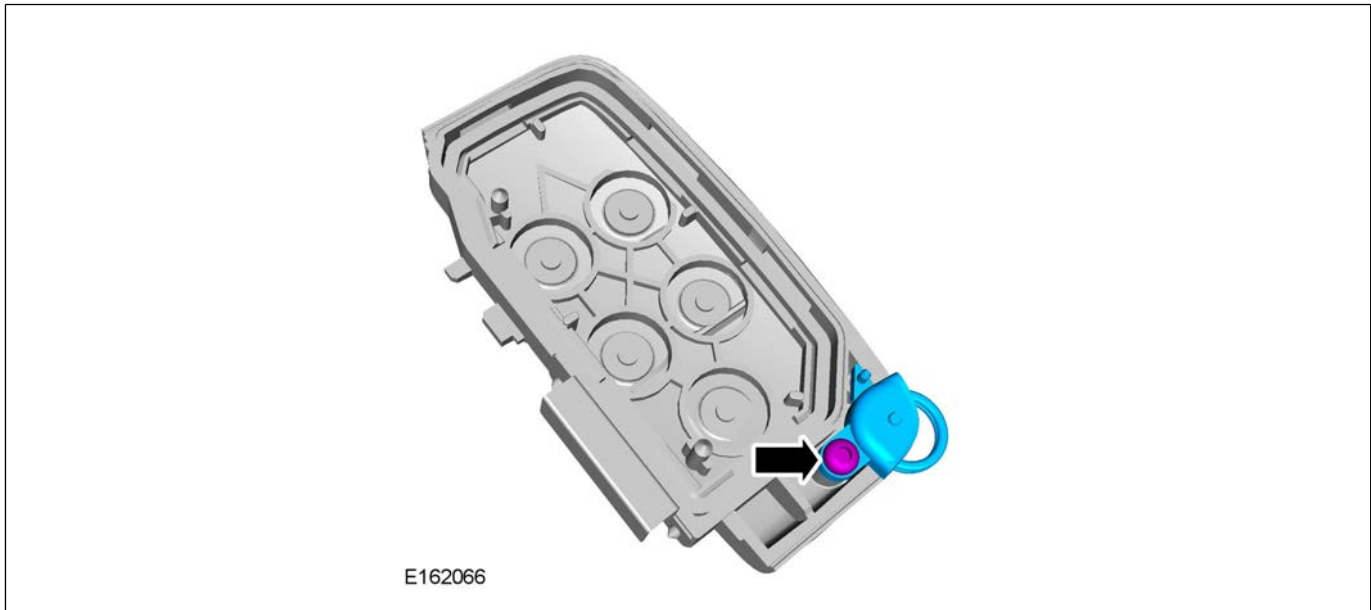

12. Install the key ring retainer to the upper case:

- Tighten to 1Nm.



13. Make sure the key ring retaining pin is present in the upper case.



14.  CAUTION: When installing the PCB, only handle the outer edges of the board.
 NOTE: The PCB and cover are held in position with the foam pads on the new upper case.

Install the PCB to the upper case.

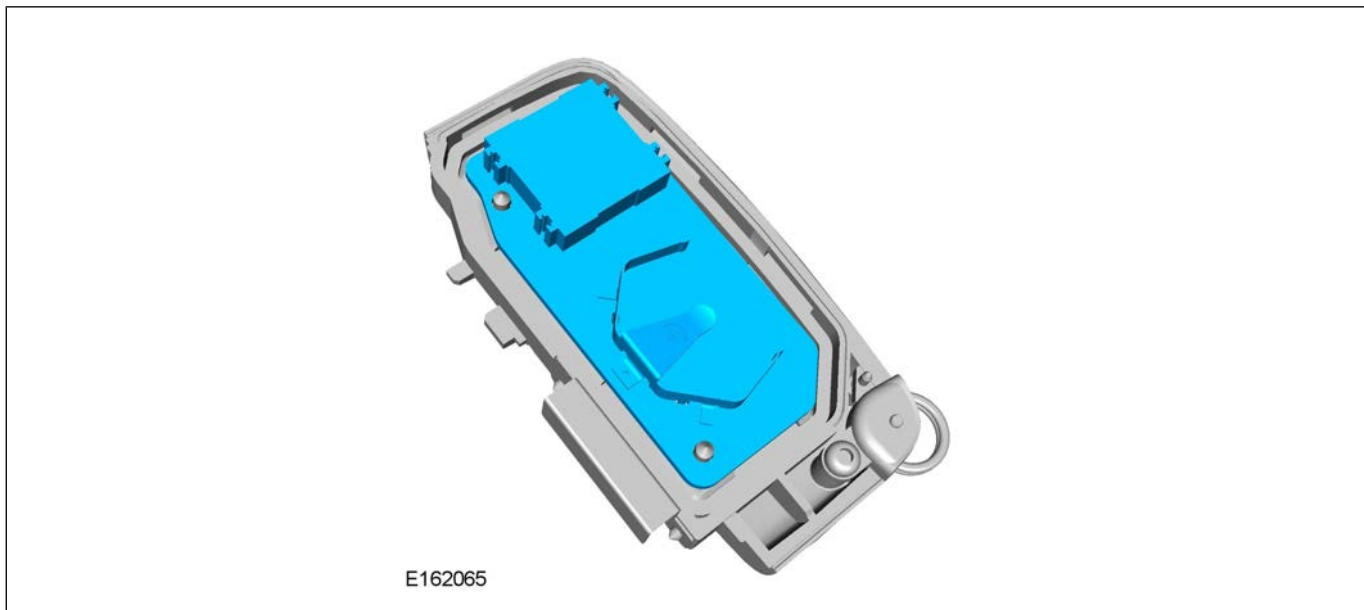

15. Install the PCB anti-tamper cover.

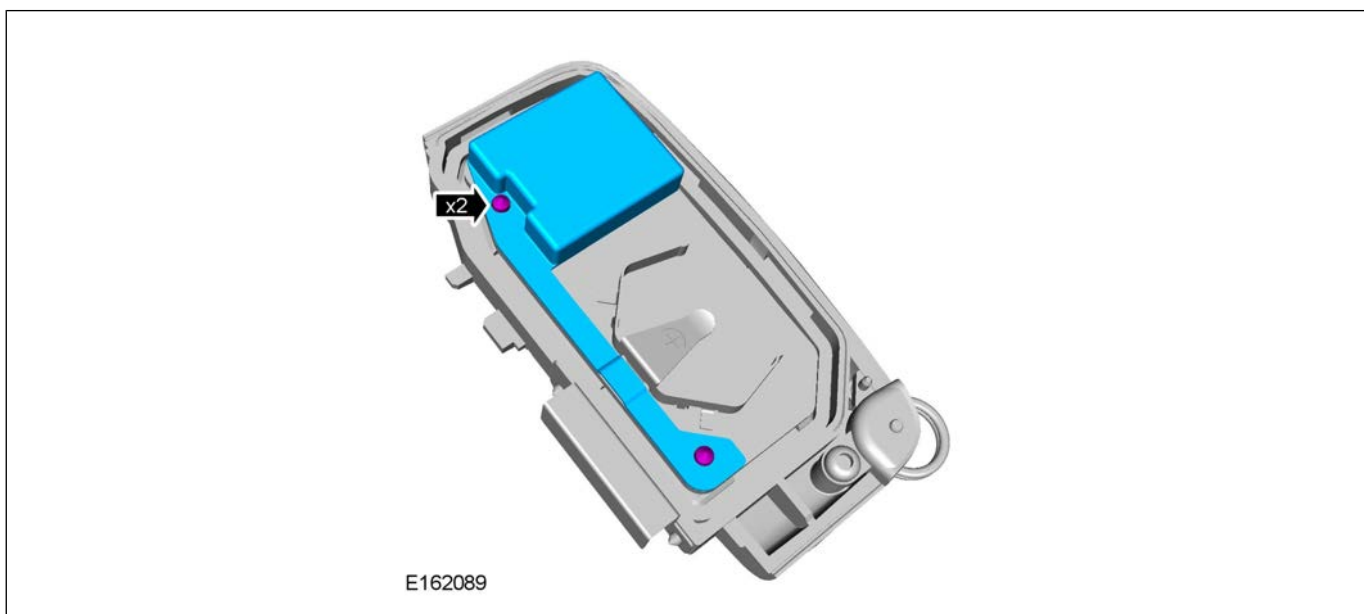

16.  NOTE: Make sure the battery is installed positive (+) side **up**.

Install the battery to the upper case.

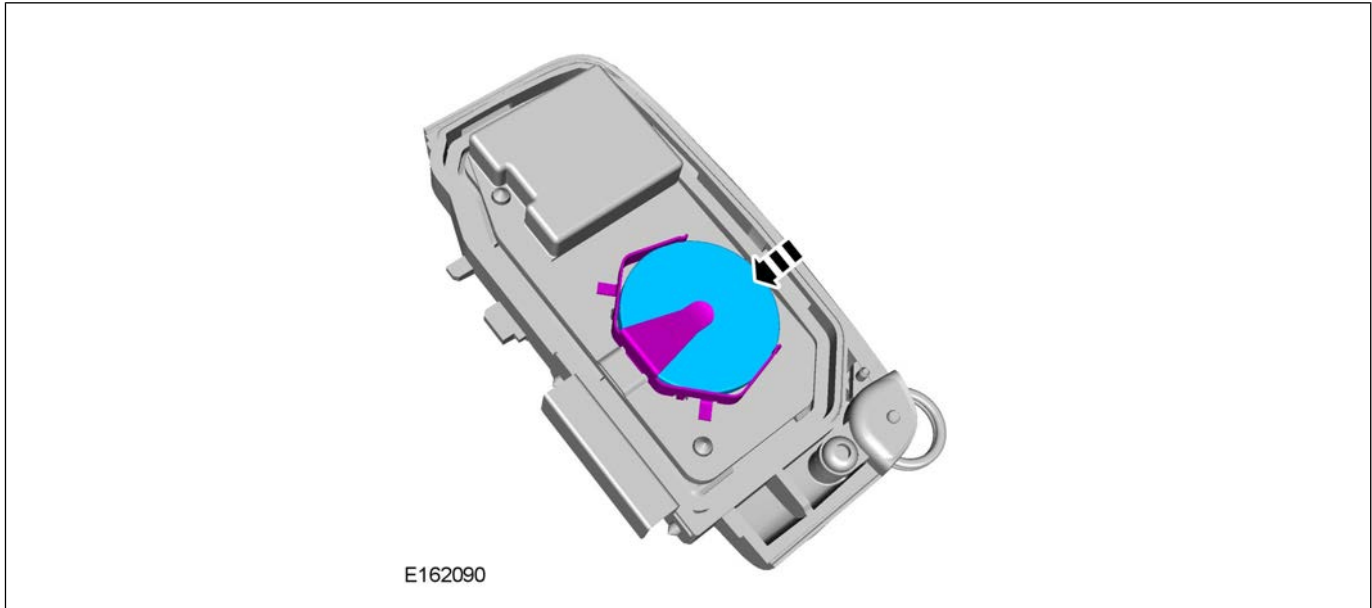

17. Install the lower case onto the handset.



18. Install the key blade.



19. Install the chrome cap.

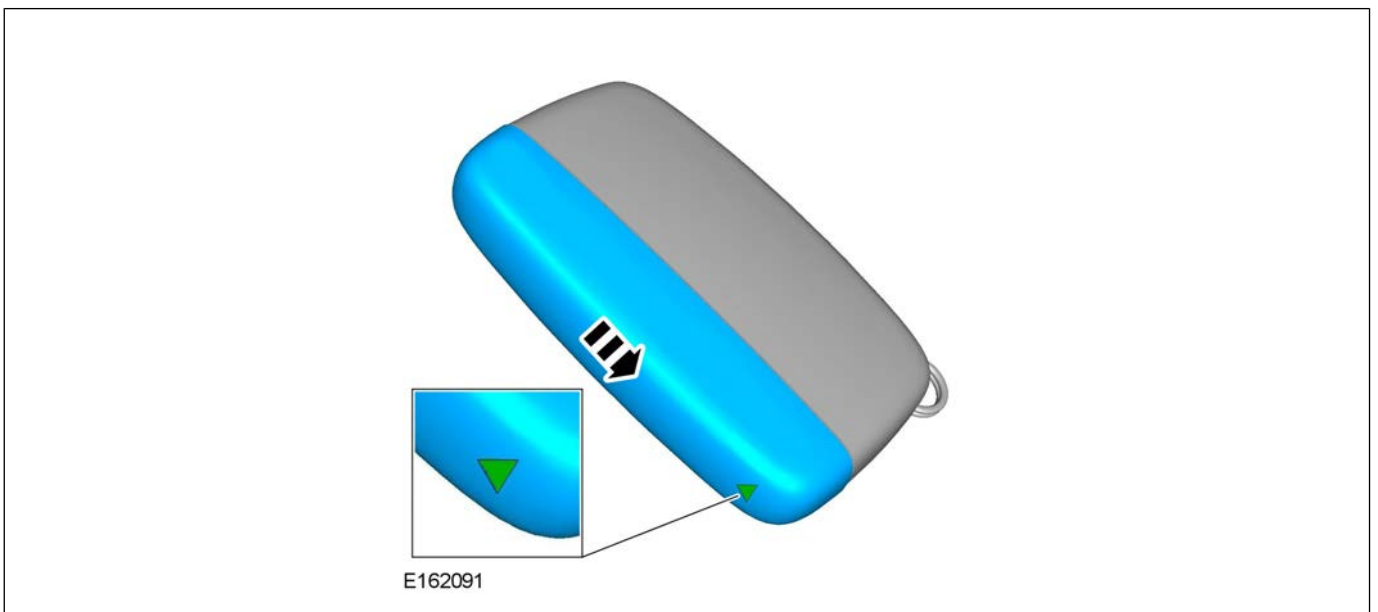

20. Check the operation of the compact key handset (all functions).

21. Perform steps 2-20 as necessary to customer's additional compact key handsets.

14 FEB 2014

© Jaguar Land Rover North America, LLC

NOTE: The information in Technical Bulletins is intended for use by trained, professional Technicians with the knowledge, tools, and equipment required to do the job properly and safely. It informs these Technicians of conditions that may occur on some vehicles, or provides information that could assist in proper vehicle service. The procedures should not be performed by 'do-it-yourselfers'. If you are not a Retailer, do not assume that a condition described affects your vehicle. Contact an authorized Land Rover service facility to determine whether this bulletin applies to a specific vehicle.

Changes are highlighted in blue

This reissue replaces all previous versions. Please destroy all previous versions.

SECTION: 501-14

Compact Key Handset - Lower-Level Service Repair

AFFECTED VEHICLE RANGE:

LR2 (LF)

Model Year:2013-2014

VIN: DH303399-EH385500

LR4 (LA)

Model Year:2012-2013

VIN: CA582668-DA700486

Range Rover Evoque (LV)

Model Year:2012-2014

VIN: CH000447-EH862000

Range Rover Sport (LW)

Model Year:2014

VIN: EA000002-EA328222

Range Rover (LG)

Model Year:2013-2014

VIN: DA000083-EA145851

Range Rover Sport (LS)

Model Year:2012-2013

VIN: CA299939-DA814146

MARKETS:

NAS

CONDITION SUMMARY:

Situation: The face of the compact key handset may peel away from the handset main body or the handset case may be bulging.

Cause: This may be caused by the handset manufacturing process.

△ NOTE: Replace only the affected compact key handset; it is not necessary to replace both handsets. All customer handsets must match after the conclusion of the repair.

Action: Should the customer express this concern, follow the Service Instruction outlined below.

PARTS:

△ NOTE: One (1) kit required per handset.

LR059382	Compact key kit (gloss finish) - LR2, LR4	1
LR059383	Compact key kit (gloss finish) - Range Rover Evoque, Range Rover Sport, Range Rover	1
LR059384	Compact key kit (matte finish) - Range Rover Evoque, Range Rover Sport, Range Rover	1

WARRANTY:

△ NOTE: SRO time covers one (1) handset (may be used per handset repaired when applicable).

△ **NOTE:** Repair procedures are under constant review, and therefore times are subject to change; those quoted here must be taken as guidance only. Always refer to TOPIx to obtain the latest repair time.

△ **NOTE:** The JLR Claims Submission System requires the use of causal part numbers. Labor only claims must show the causal part number with a quantity of zero.

DESCRIPTION	SRO	TIME (HOURS)	CONDITION CODE	CAUSAL PART
Casing - 'Land Rover' embossed - Handset/Compact key - One - Renew - LR2, LR4	86 77 36	0.1	49	LR029695
Casing - Handset/Compact key - Renew - One - Range Rover Evoque, Range Rover Sport, Range Rover	86 77 36	0.1	49	LR027451

△ **NOTE:** Normal Warranty procedures apply.

SERVICE INSTRUCTION:

△ **NOTE:** Replace only the affected compact key handset; it is not necessary to replace both handsets. All customer handsets must match after the conclusion of the repair.

Step 1: Range Rover Evoque, Range Rover Sport, and Range Rover vehicles only.

1. Identify the type of compact key handset currently fitted to the vehicle to ensure a like-for-like replacement handset is fitted:
 - Left = matte finish.
 - Right = gloss finish.



△ **NOTE:** Please refer to SSM70798, 'Compact key low level repair - animation of process', to view the animation file.

2. Remove the chrome cap; place to one side.

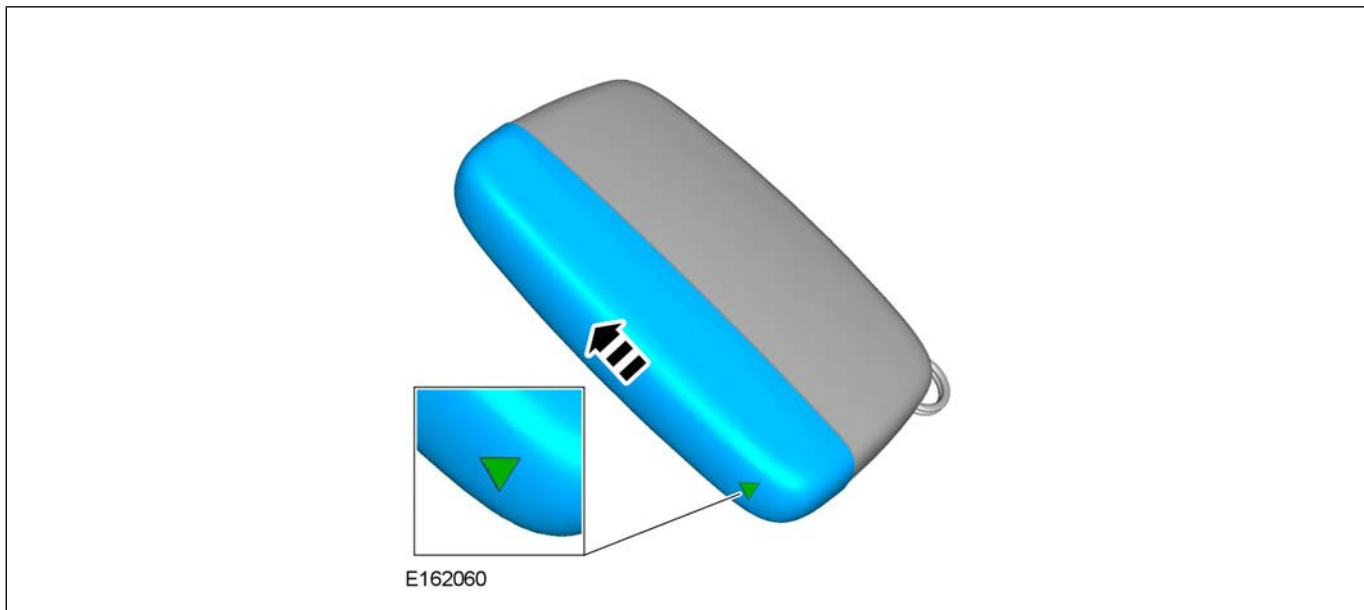

3. Remove the key blade.



4. Using the key blade, remove and discard the lower case.

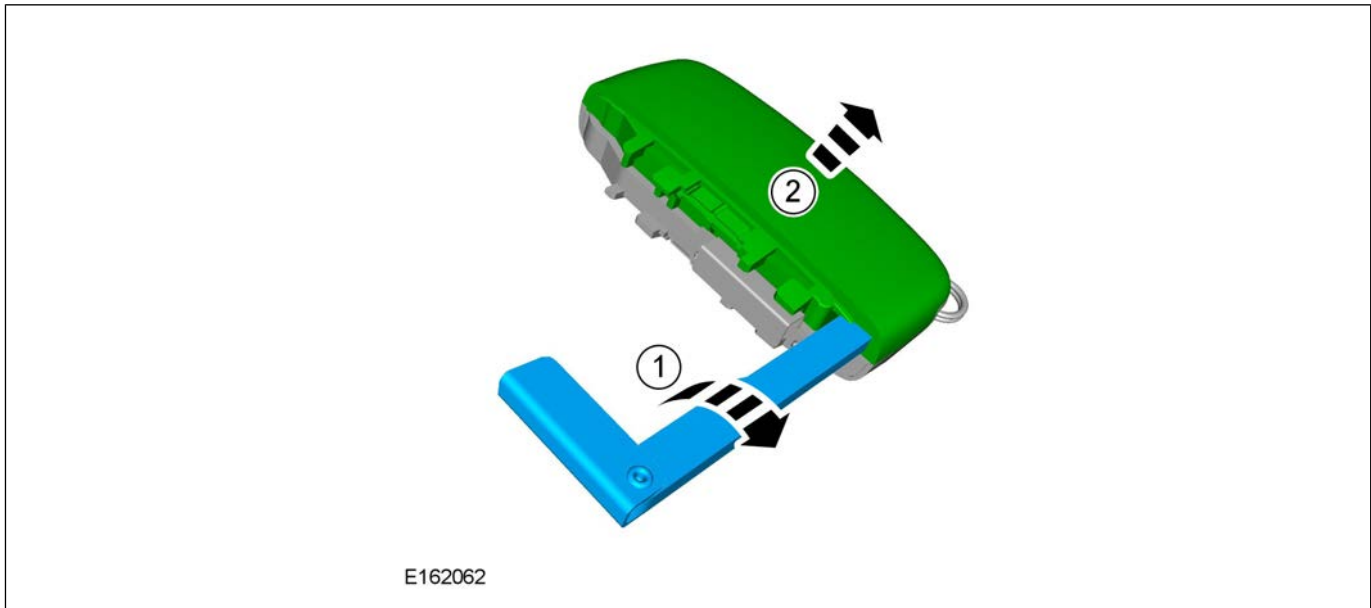

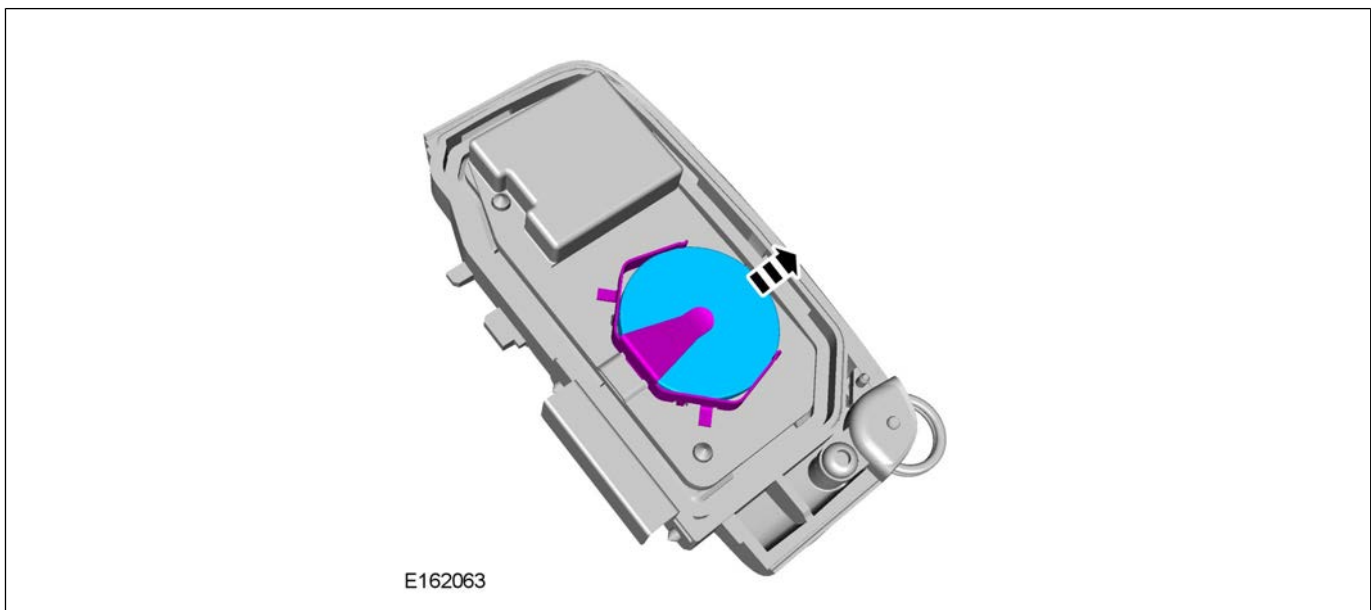

5. Remove the battery from the upper case.

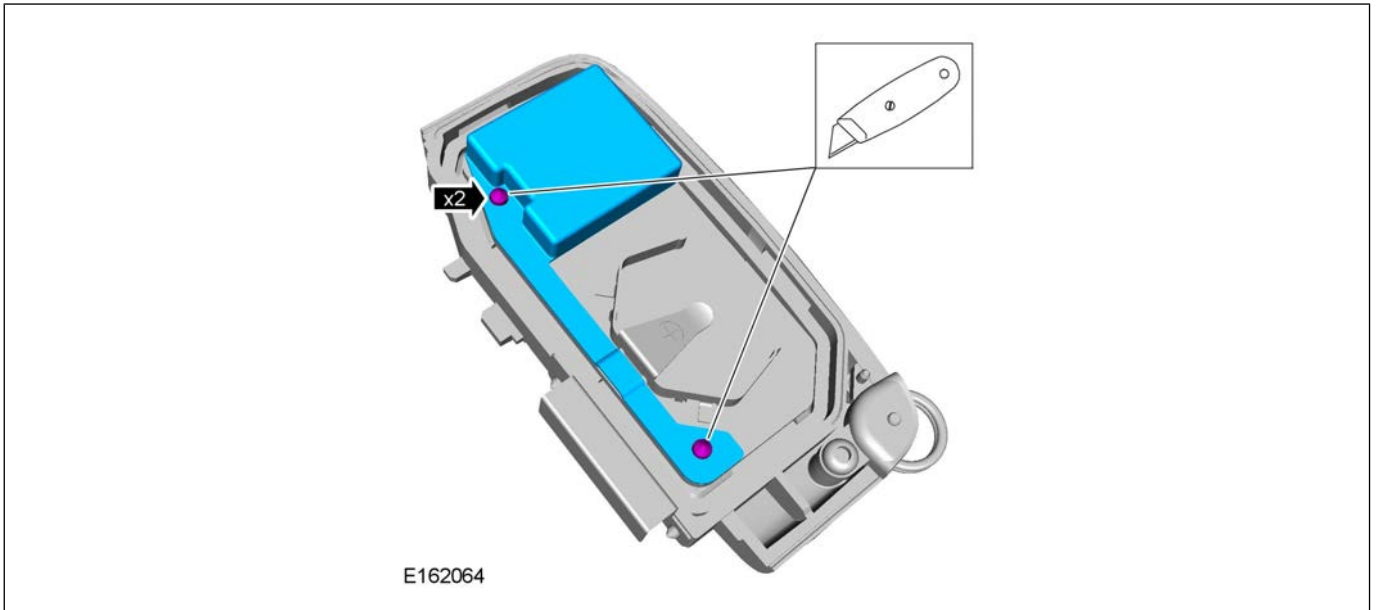

6. **⚠ CAUTION:** Make sure the Printed Circuit Board (PCB) is not damaged when removing the black anti-tamper cover. If the copper coil antenna is damaged, the unit will be unserviceable.

Using a suitable tool, cut the fixings of the black anti-tamper cover and lift away from the Printed Circuit Board (PCB).



7.  CAUTION: When removing the PCB, only handle the outer edges of the board.
Remove the PCB; place to one side.

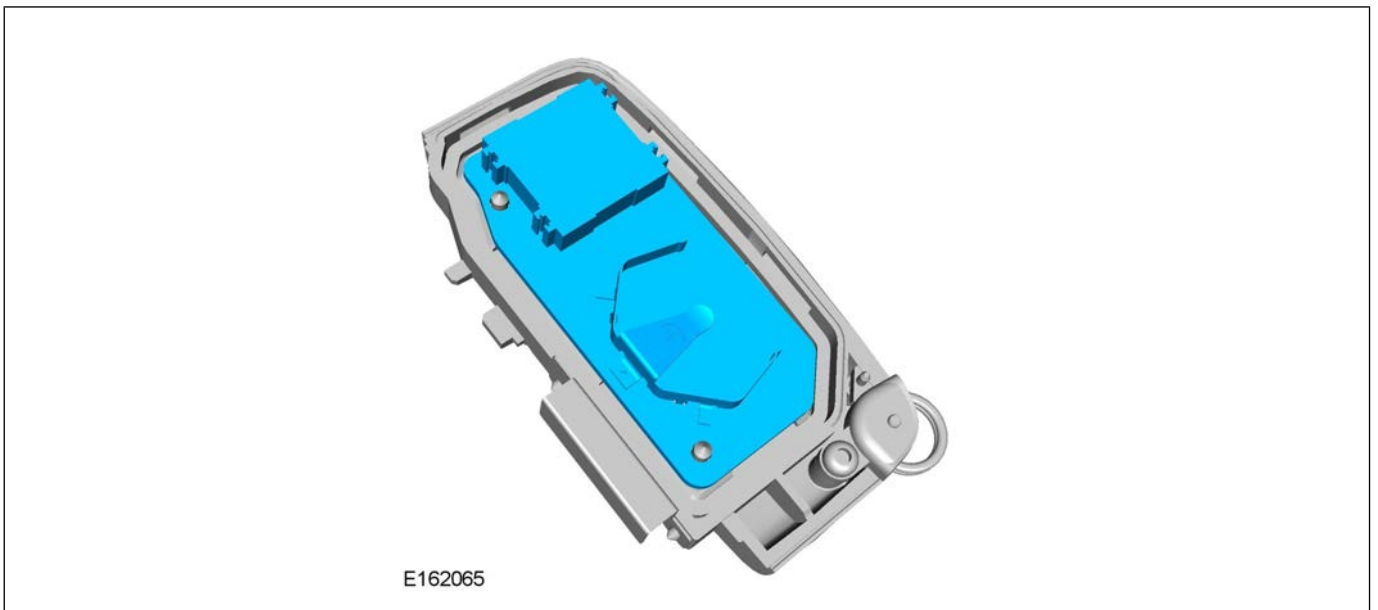

8. Remove the key ring retainer; place to one side.

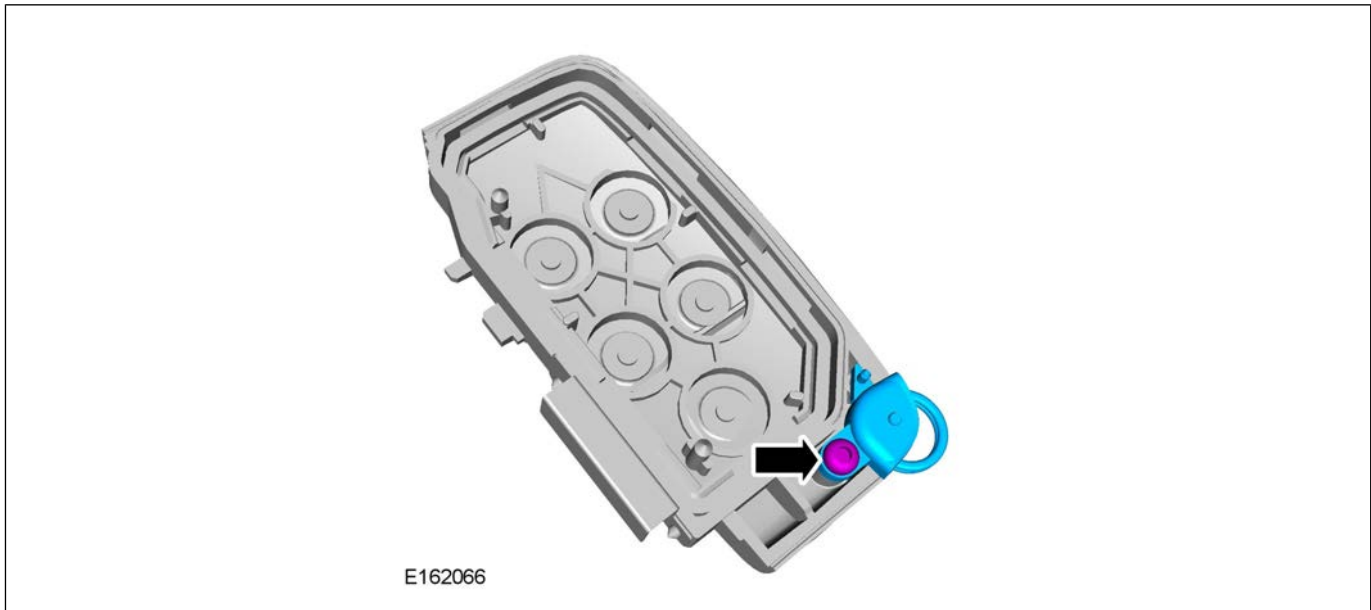

9. Remove the silicone seal from the lower case; place to one side.

- Discard the upper case.
-



10. Make sure the foam pads are installed in the lower case as shown.

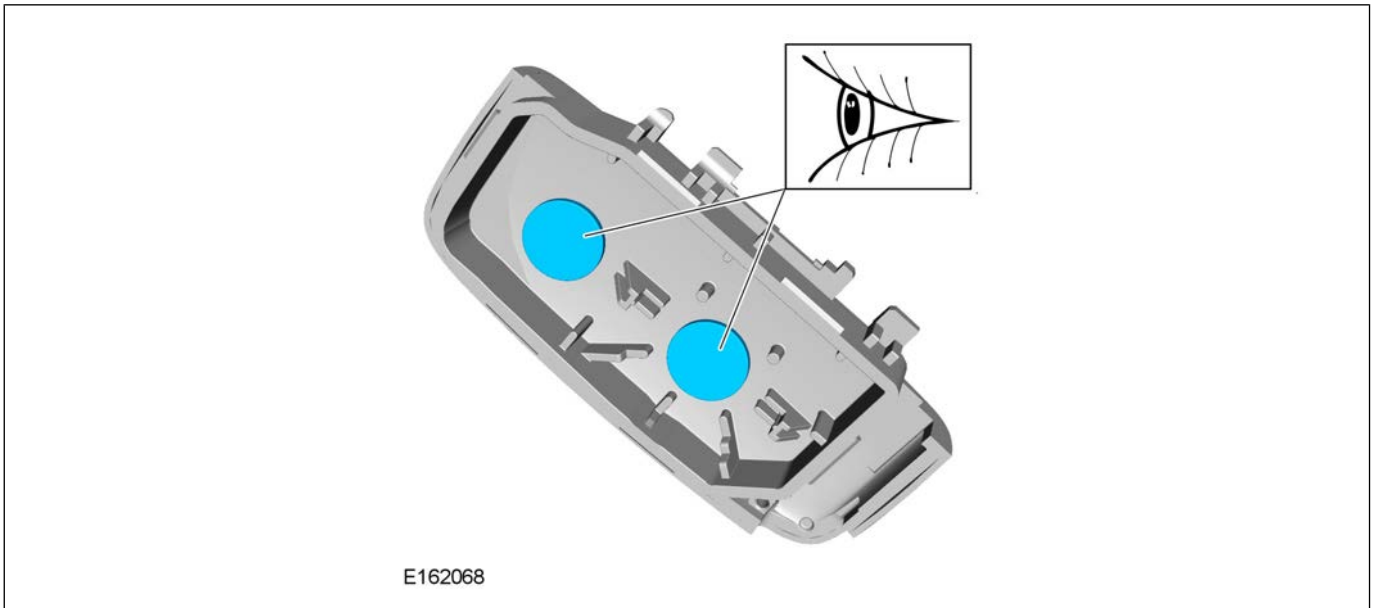

11. Install the silicone seal to the upper case.

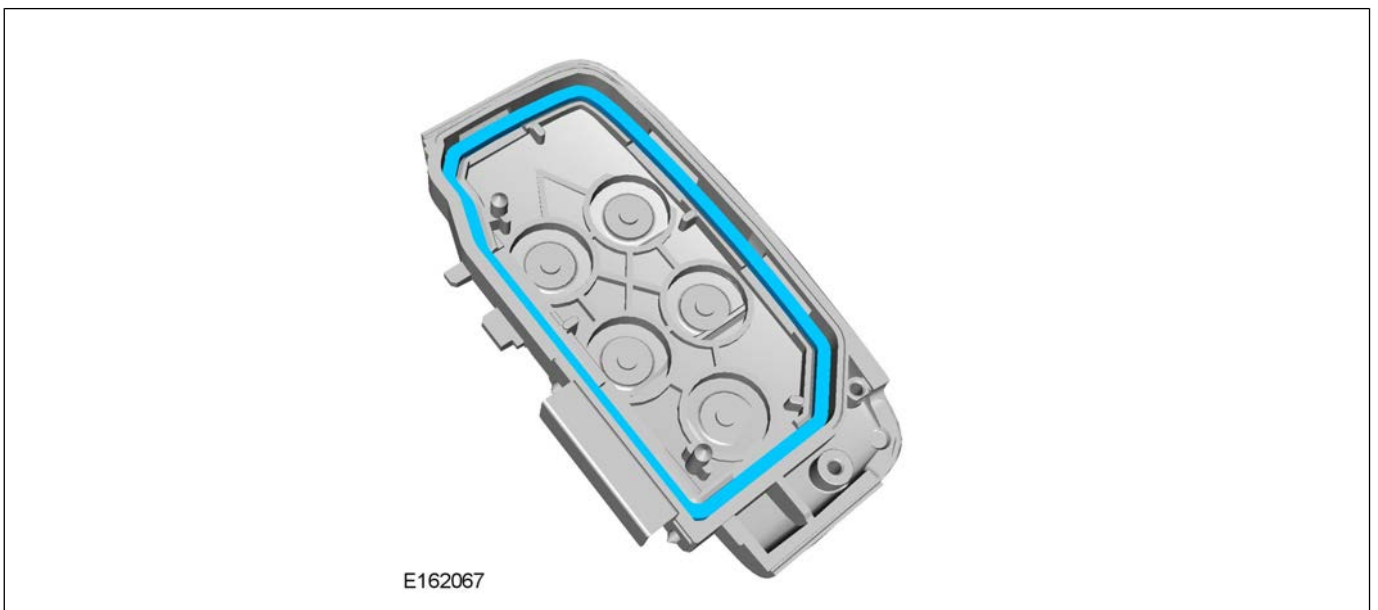

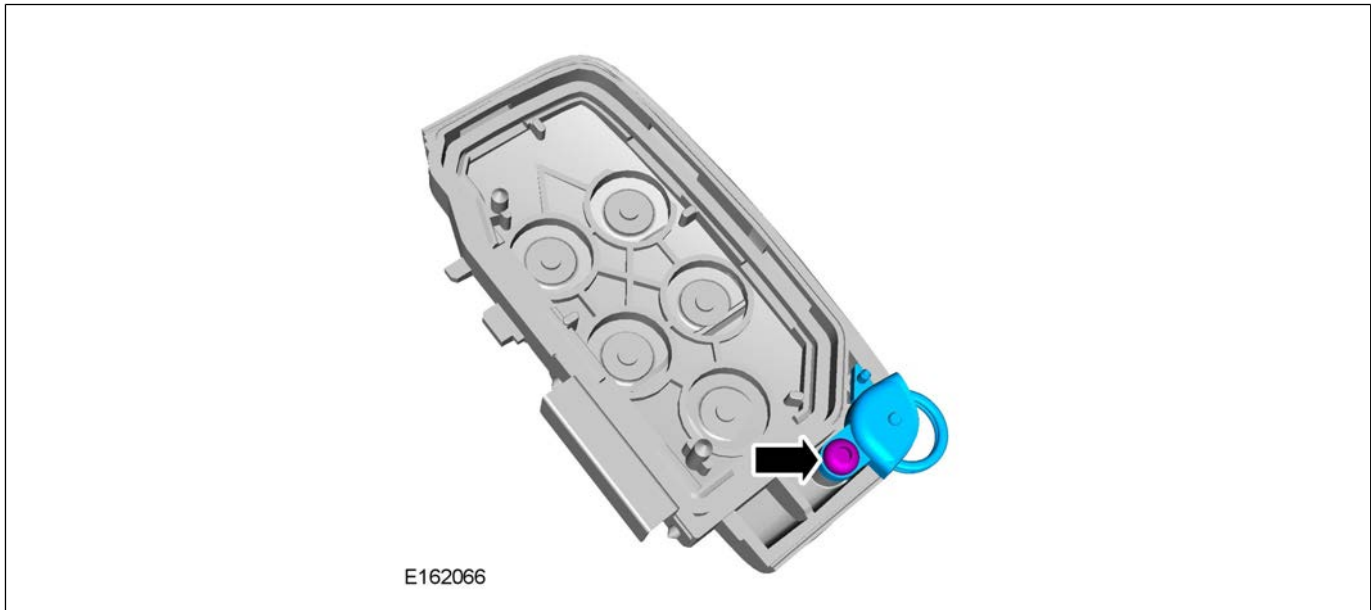

12. Install the key ring retainer to the upper case:

- Tighten to 1Nm.



13. Make sure the key ring retaining pin is present in the upper case.



14.  CAUTION: When installing the PCB, only handle the outer edges of the board.
 NOTE: The PCB and cover are held in position with the foam pads on the new upper case.

Install the PCB to the upper case.

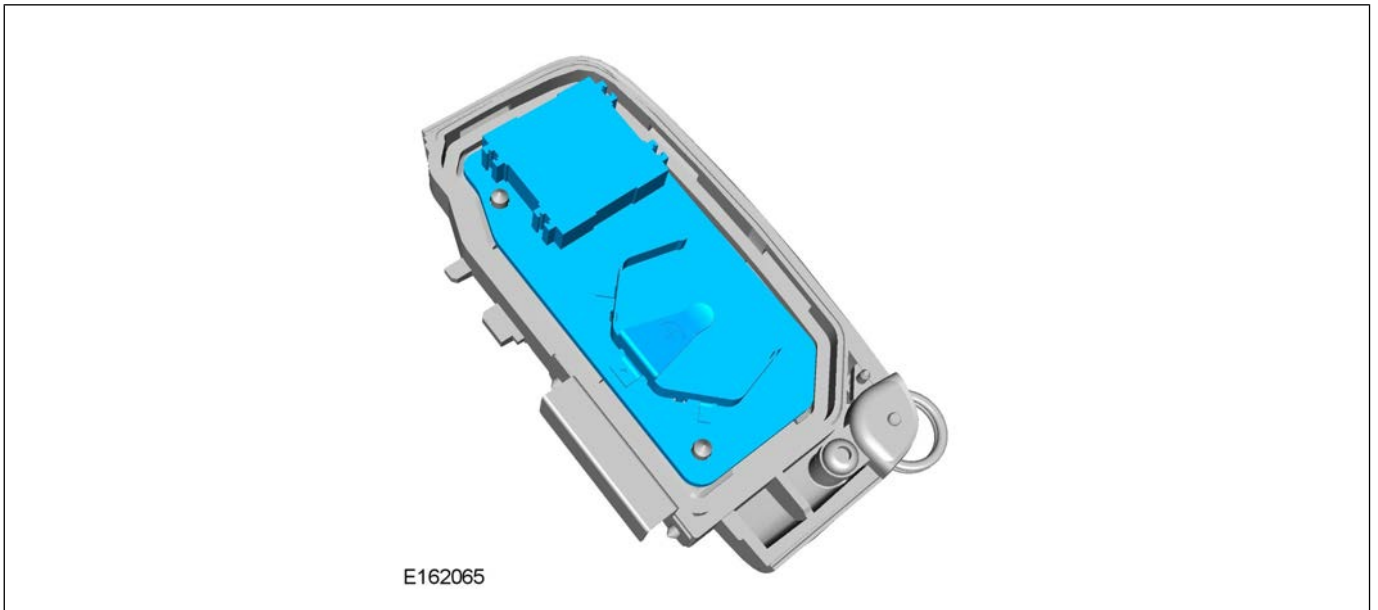

15. Install the PCB anti-tamper cover.

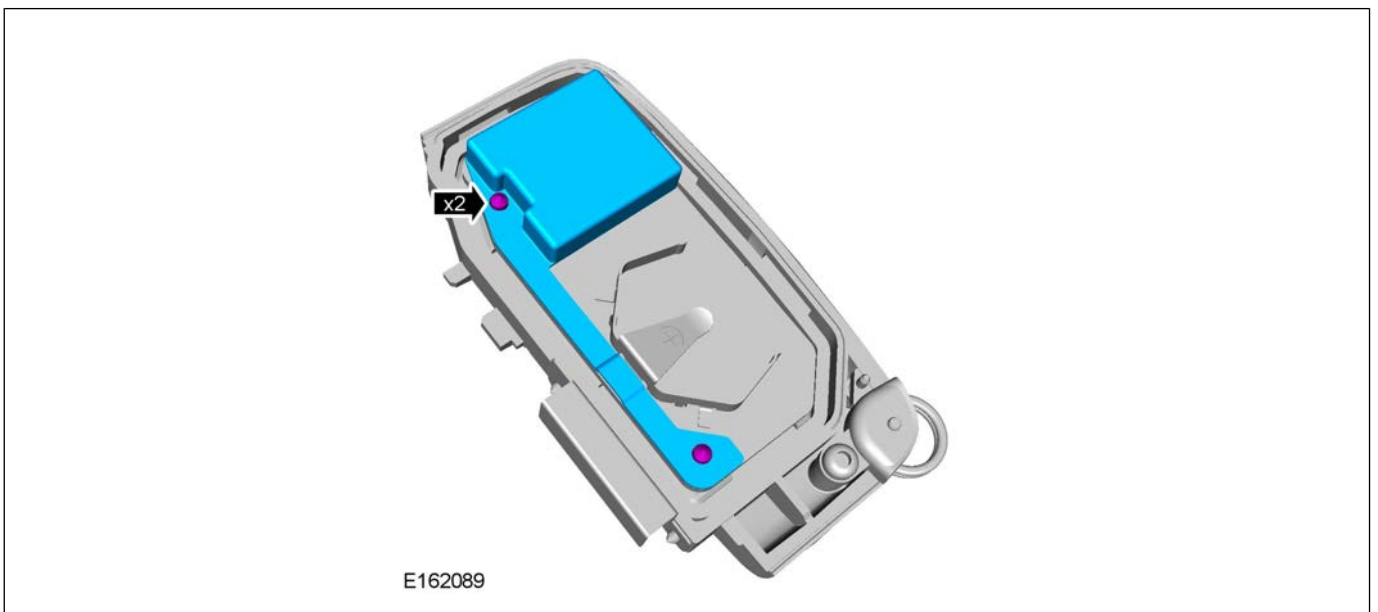

16. **△ NOTE: Make sure the battery is installed positive (+) side up.**

Install the battery to the upper case.

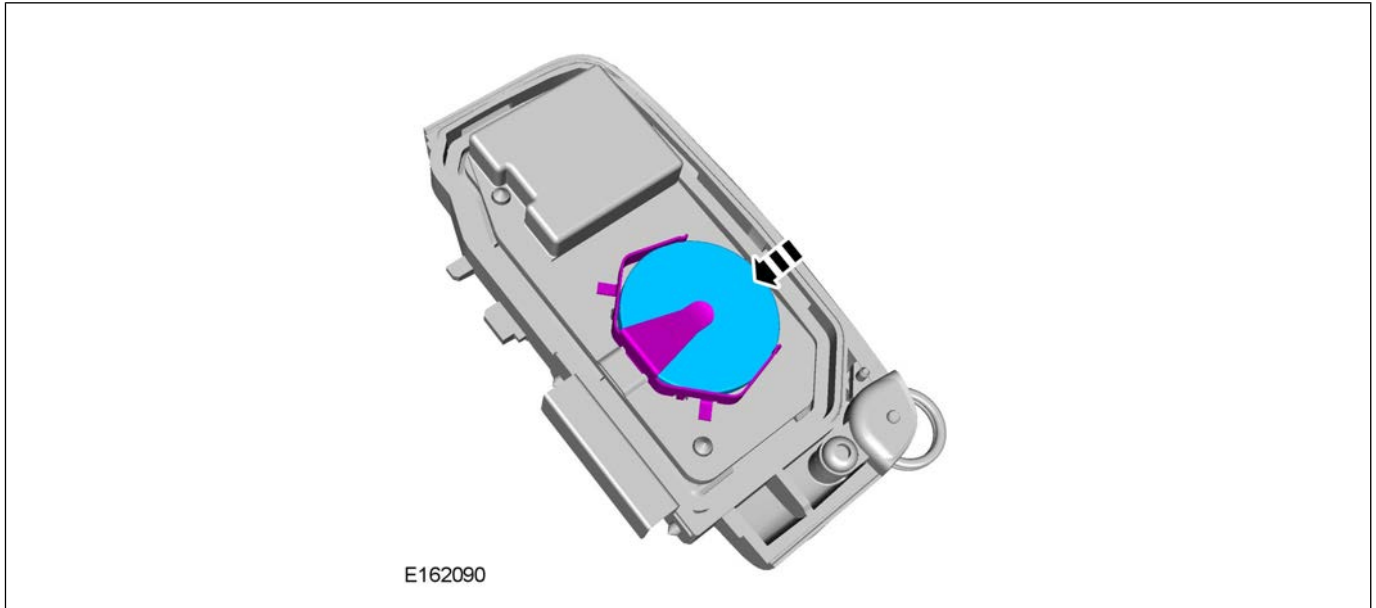

17. Install the lower case onto the handset.



18. Install the key blade.



19. Install the chrome cap.

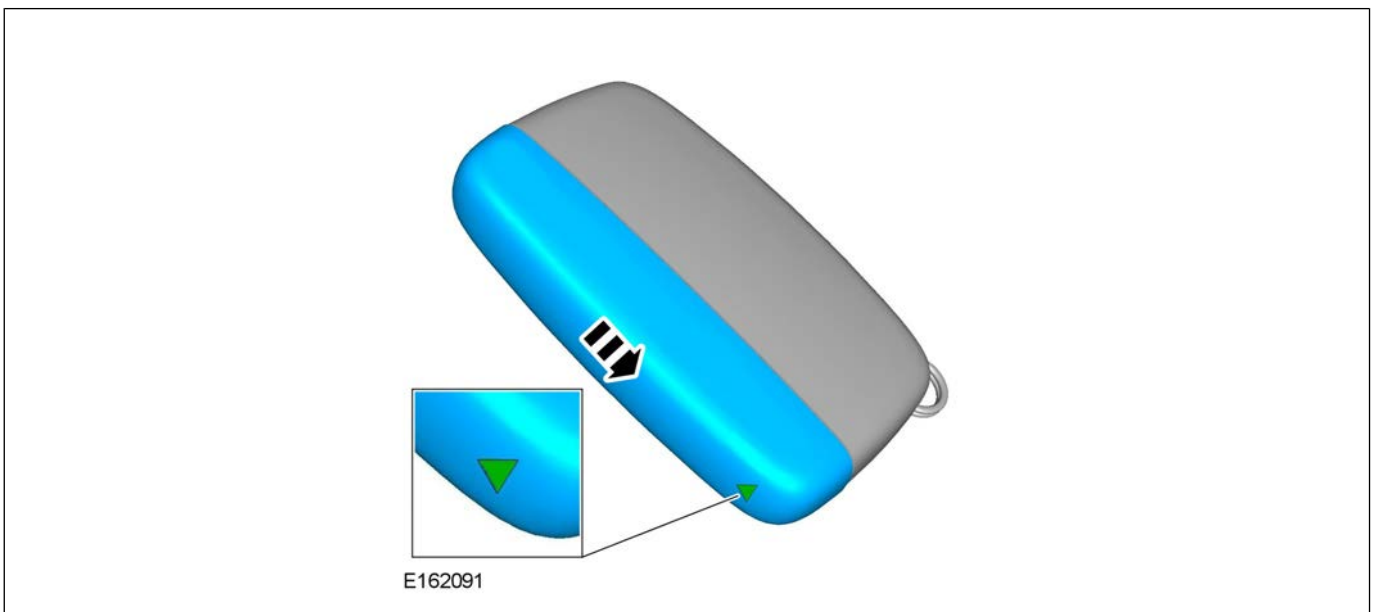

20. Check the operation of the compact key handset (all functions).

21. Perform steps 2-20 as necessary to customer's additional compact key handsets.



© Jaguar Land Rover North America, LLC

NOTE: The information in Technical Bulletins is intended for use by trained, professional Technicians with the knowledge, tools, and equipment required to do the job properly and safely. It informs these Technicians of conditions that may occur on some vehicles, or provides information that could assist in proper vehicle service. The procedures should not be performed by 'do-it-yourselfers'. If you are not a Retailer, do not assume that a condition described affects your vehicle. Contact an authorized Land Rover service facility to determine whether this bulletin applies to a specific vehicle.

This reissue replaces all previous versions. Please destroy all previous versions.

SECTION: 501-14

Compact Key Handset - Lower-Level Service Repair

AFFECTED VEHICLE RANGE:

LR2 (LF)

Model Year:2013-2014

VIN: DH303399-EH403906

LR4 (LA)

Model Year:2012-2014

VIN: CA582668-EA814146

Range Rover Evoque (LV)

Model Year:2012-2014

VIN: CH000447-EH899630

Range Rover Sport (LW)

Model Year:2014

VIN: EA000002-EA3358064

Range Rover (LG)

Model Year:2013-2014

VIN: DA000083-EA163193

Range Rover Sport (LS)

Model Year:2012-2013

VIN: CA299939-DA814146

MARKETS:

NAS

CONDITION SUMMARY:

Situation: The face of the compact key handset may peel away from the handset main body or the handset case may be bulging.

Cause: This may be caused by the handset manufacturing process.

△ **NOTE:** replace only the affected compact key handset; it is not necessary to replace both handsets. All customer handsets must match after the conclusion of the repair.

Action: Should the customer express this concern, follow the Service Instruction outlined below.

PARTS:

△ **NOTE:** one (1) kit required per handset.

LR059382	Compact key kit (gloss finish) - LR2, LR4	1
LR059383	Compact key kit (gloss finish) - Range Rover Evoque, Range Rover Sport, Range Rover	1
LR059384	Compact key kit (matte finish) - Range Rover Evoque, Range Rover Sport, Range Rover	1

WARRANTY:

△ **NOTE:** SRO time covers one (1) handset (may be used per handset repaired when applicable).

△ **NOTE:** Repair procedures are under constant review, and therefore times are subject to change; those quoted here must be taken as guidance only. Always refer to TOPlx to obtain the latest repair time.

△ **NOTE:** The JLR Claims Submission System requires the use of causal part numbers. Labor only claims must show the causal part number with a quantity of zero.

DESCRIPTION	SRO	TIME (HOURS)	CONDITION CODE	CAUSAL PART
Casing - 'Land Rover' embossed - Handset/Compact key - One - Renew - LR2, LR4	86 77 36	0.1	49	LR029695
Casing - Handset/Compact key - Renew - One - Range Rover Evoque, Range Rover Sport, Range Rover	86 77 36	0.1	49	LR027451

△ **NOTE:** Normal Warranty procedures apply.

SERVICE INSTRUCTION:

△ **NOTE:** replace only the affected compact key handset; it is not necessary to replace both handsets. All customer handsets must match after the conclusion of the repair.

Step 1: Range Rover Evoque, Range Rover Sport, and Range Rover vehicles only.

1. Identify the type of compact key handset currently fitted to the vehicle to ensure a like-for-like replacement handset is fitted:

- Left = matte finish.
- Right = gloss finish.



△ **NOTE:** refer to SSM70798, 'Compact key low level repair - animation of process', to view the animation file.

2. Remove the chrome cap; place to one side.

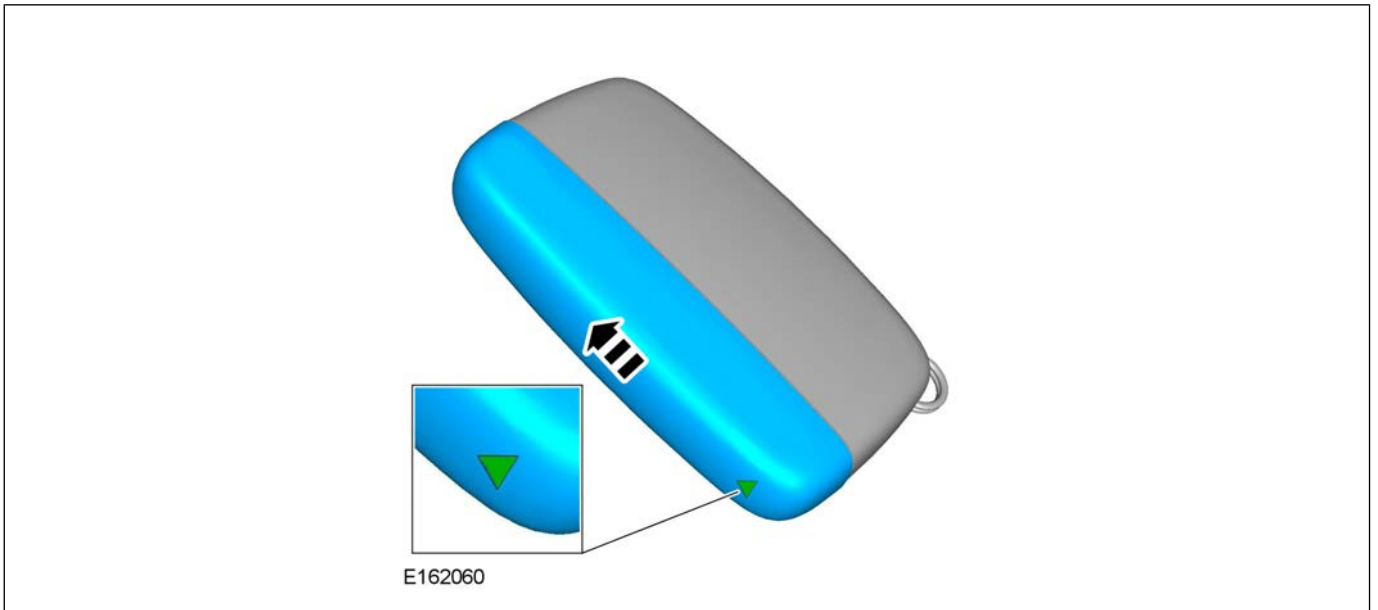

3. Remove the key blade.

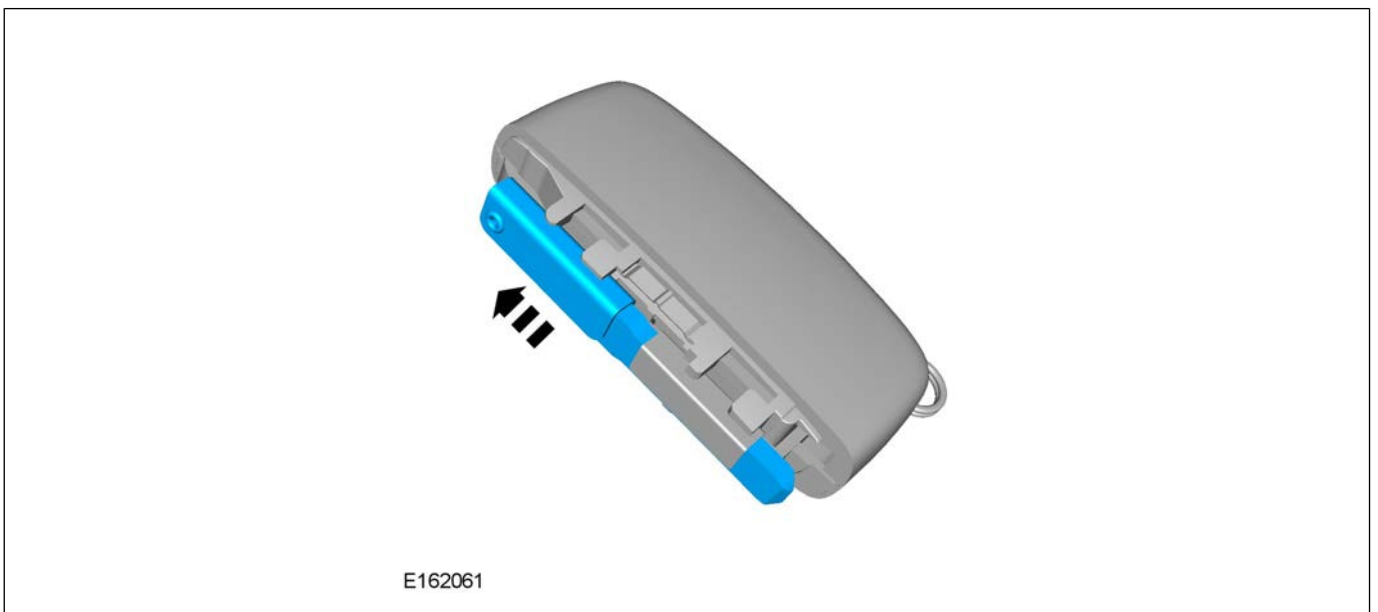

4. Using the key blade, remove and discard the lower case.

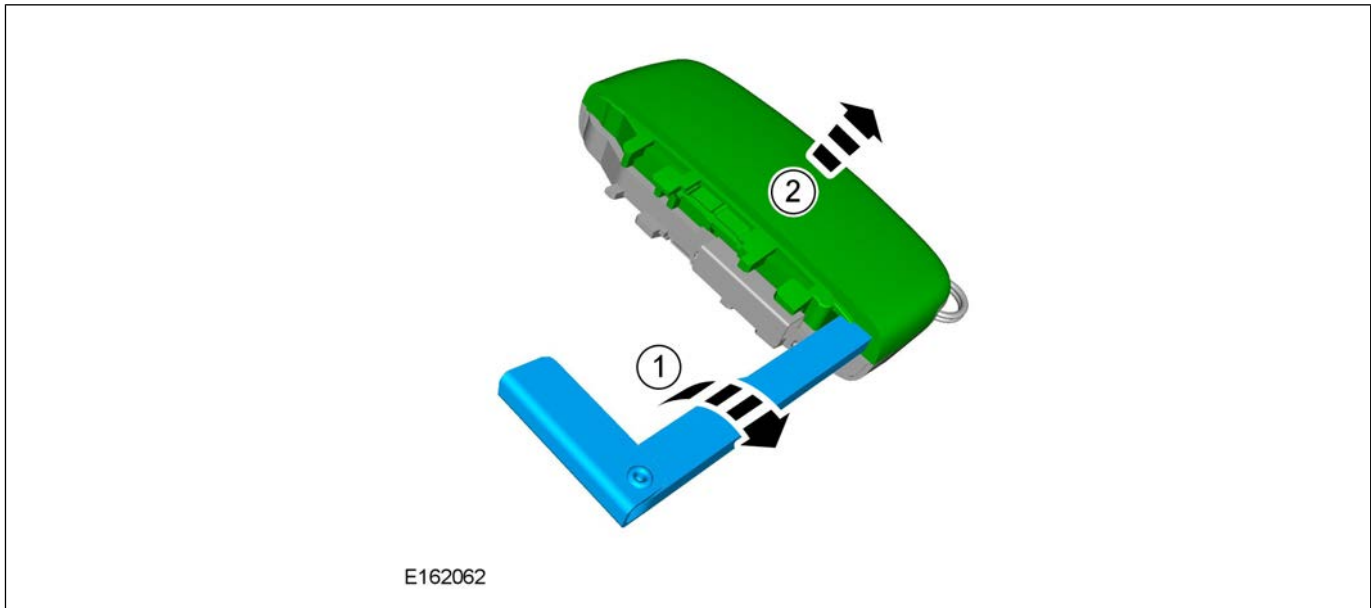

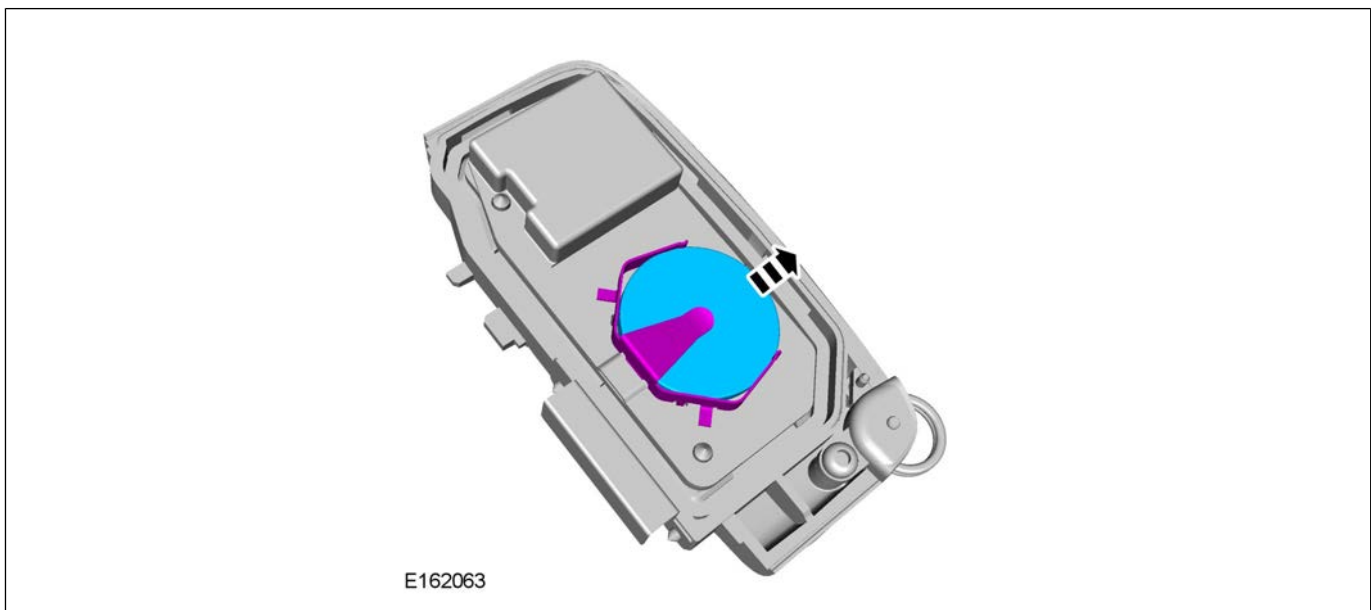

5. Remove the battery from the upper case.

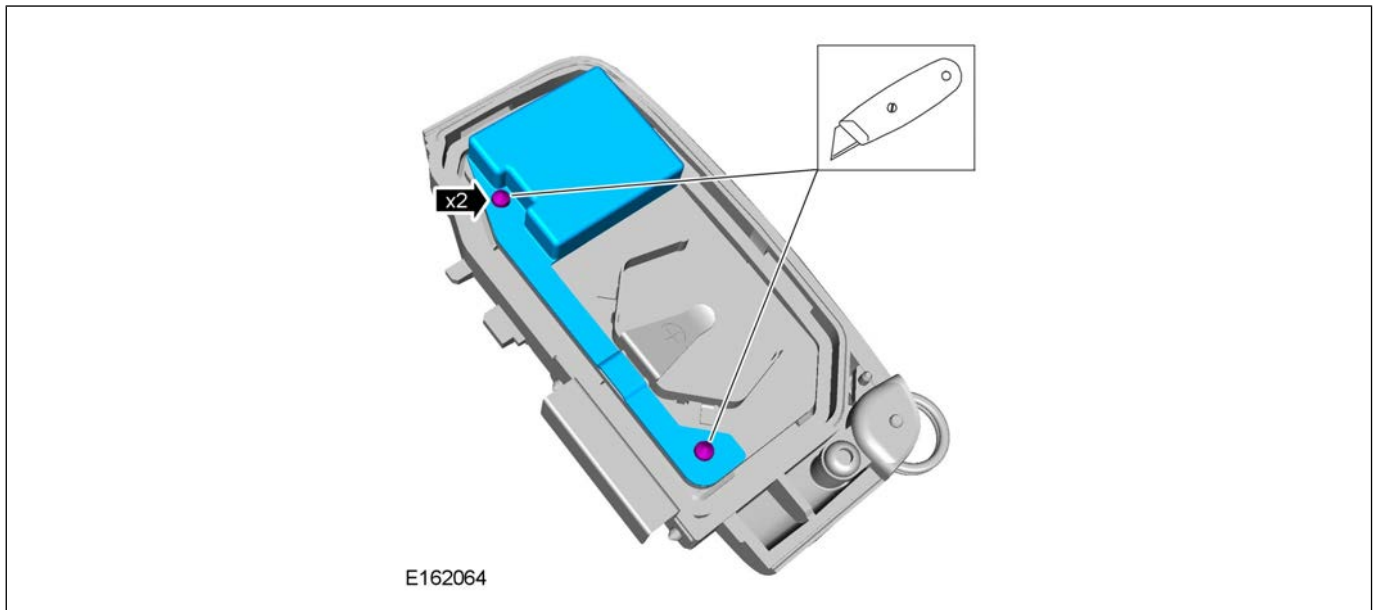

6. **⚠ CAUTION:** make sure the Printed Circuit Board (PCB) is not damaged when removing the black anti-tamper cover. If the copper coil antenna is damaged, the unit will be unserviceable.

Using a suitable tool, cut the fixings of the black anti-tamper cover and lift away from the Printed Circuit Board (PCB).



7.  CAUTION: when removing the PCB, only handle the outer edges of the board.
Remove the PCB; place to one side.

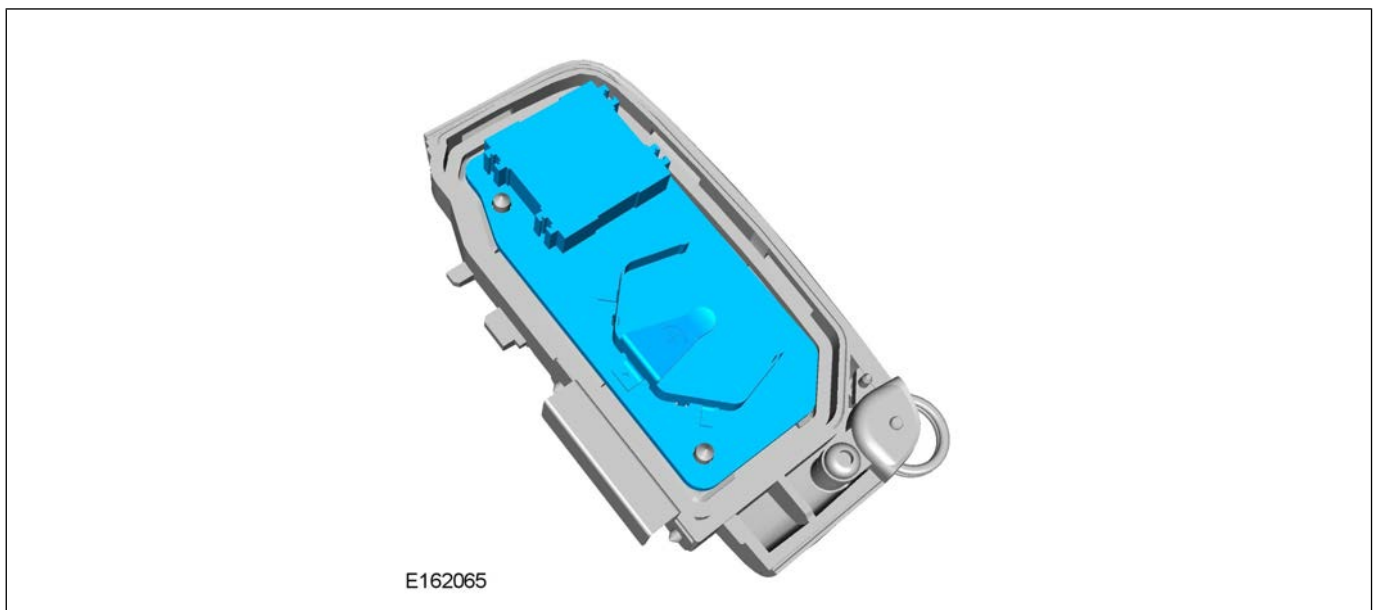

8. Remove the key ring retainer; place to one side.

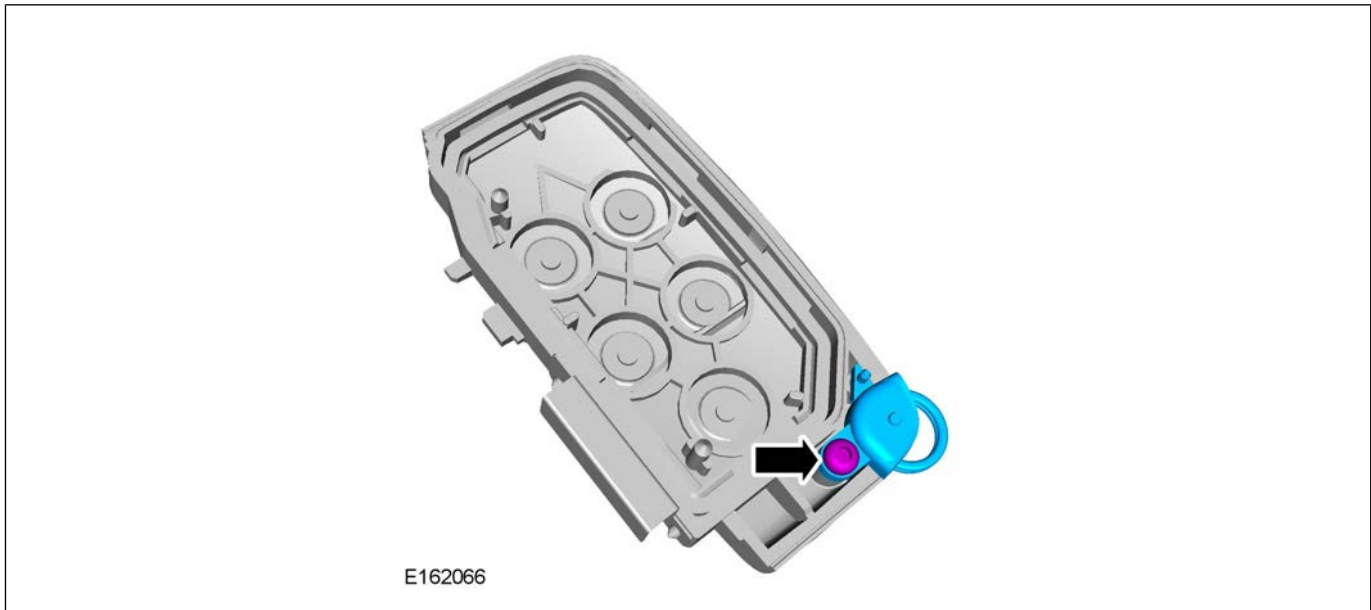

9. Remove the silicone seal from the lower case; place to one side.

- Discard the upper case.
-



10. Make sure the foam pads are installed in the lower case as shown.

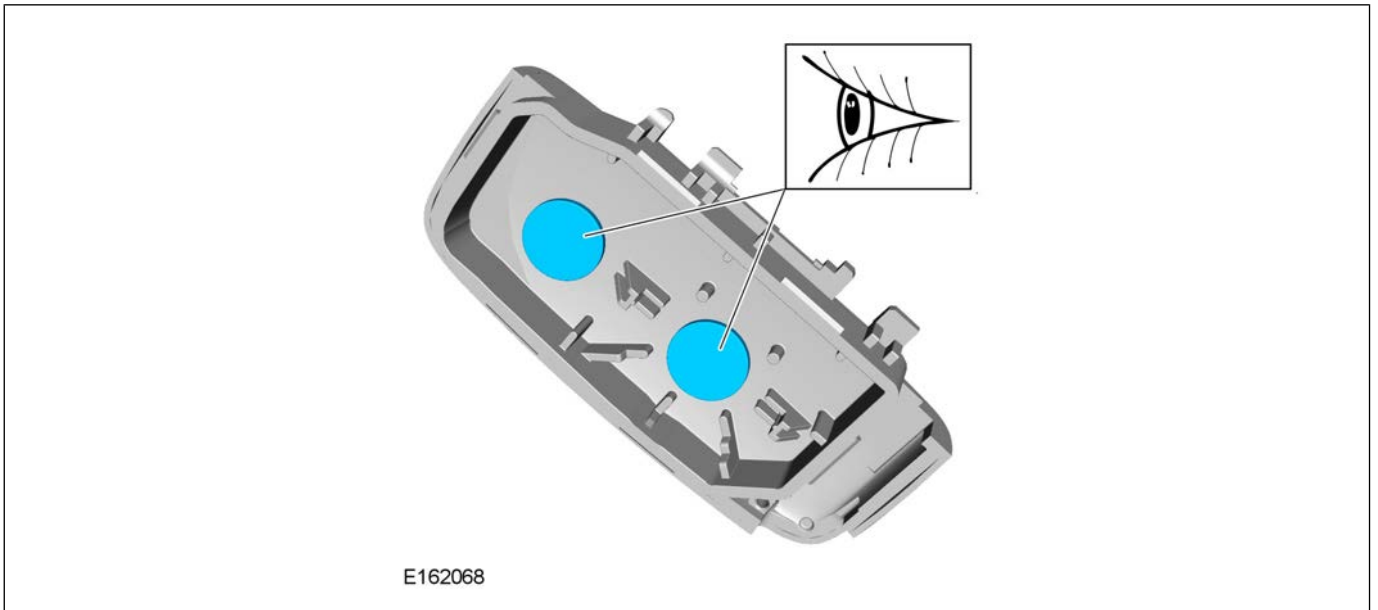

11. Install the silicone seal to the upper case.



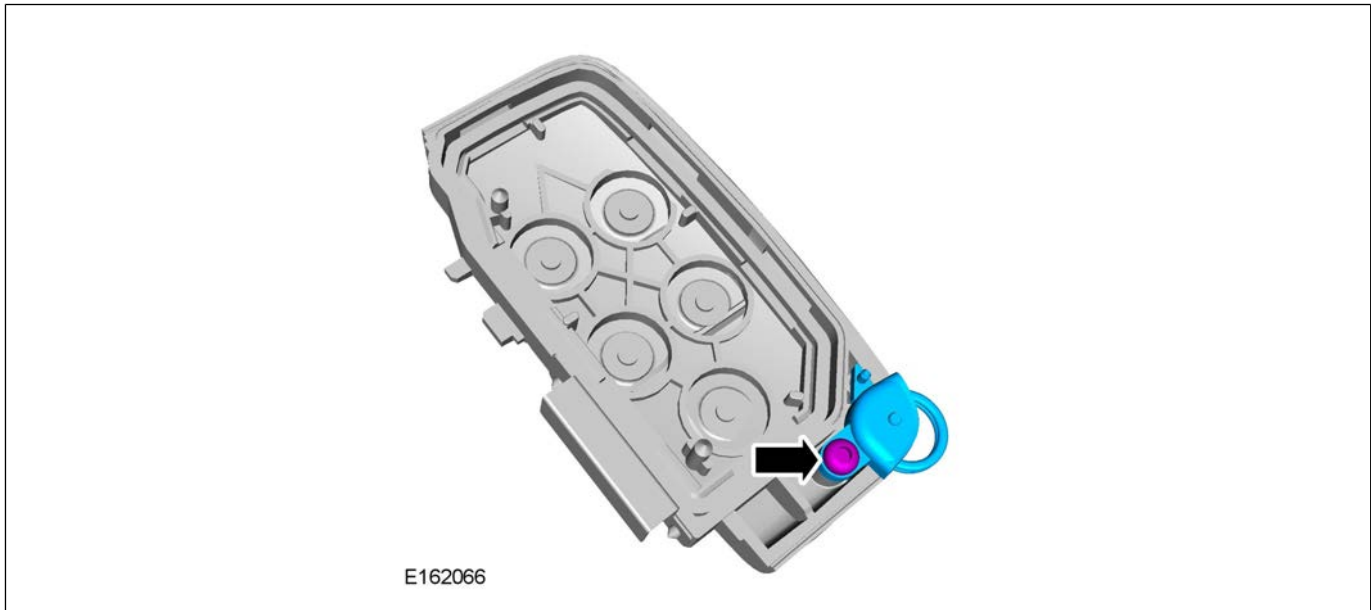

12. Install the key ring retainer to the upper case:

- Tighten to 1Nm.



13. Make sure the key ring retaining pin is present in the upper case.



14.  CAUTION: when installing the PCB, only handle the outer edges of the board.
 NOTE: the PCB and cover are held in position with the foam pads on the new upper case.

Install the PCB to the upper case.

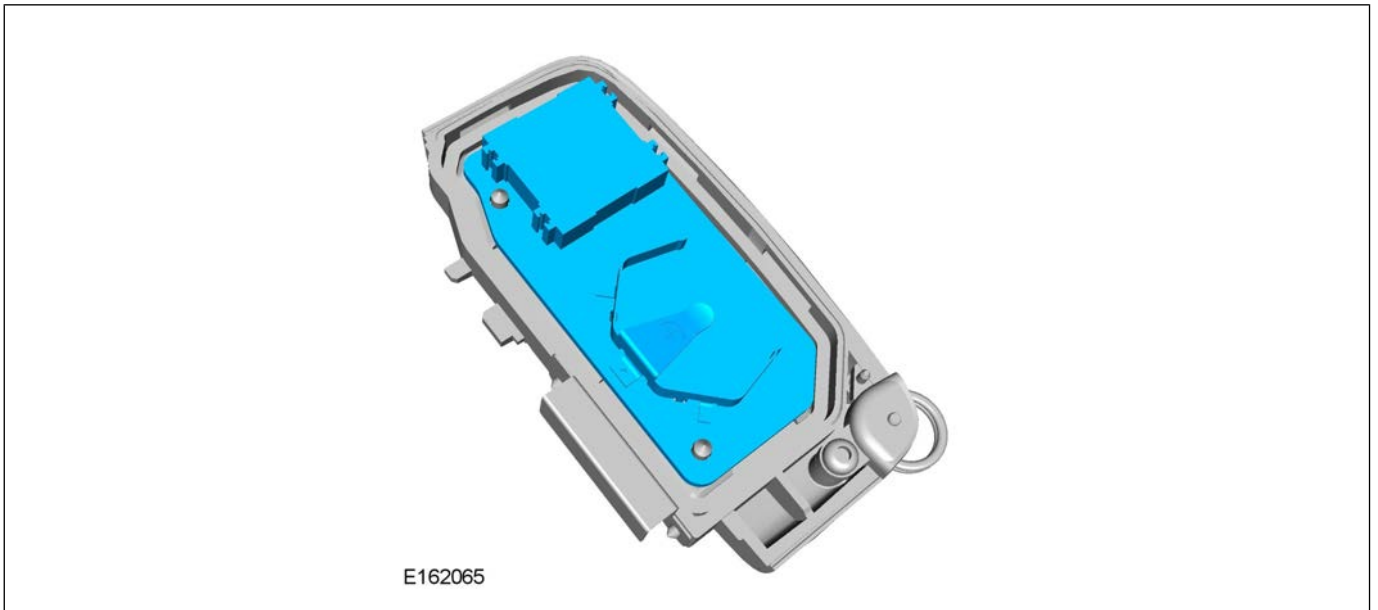

15. Install the PCB anti-tamper cover.

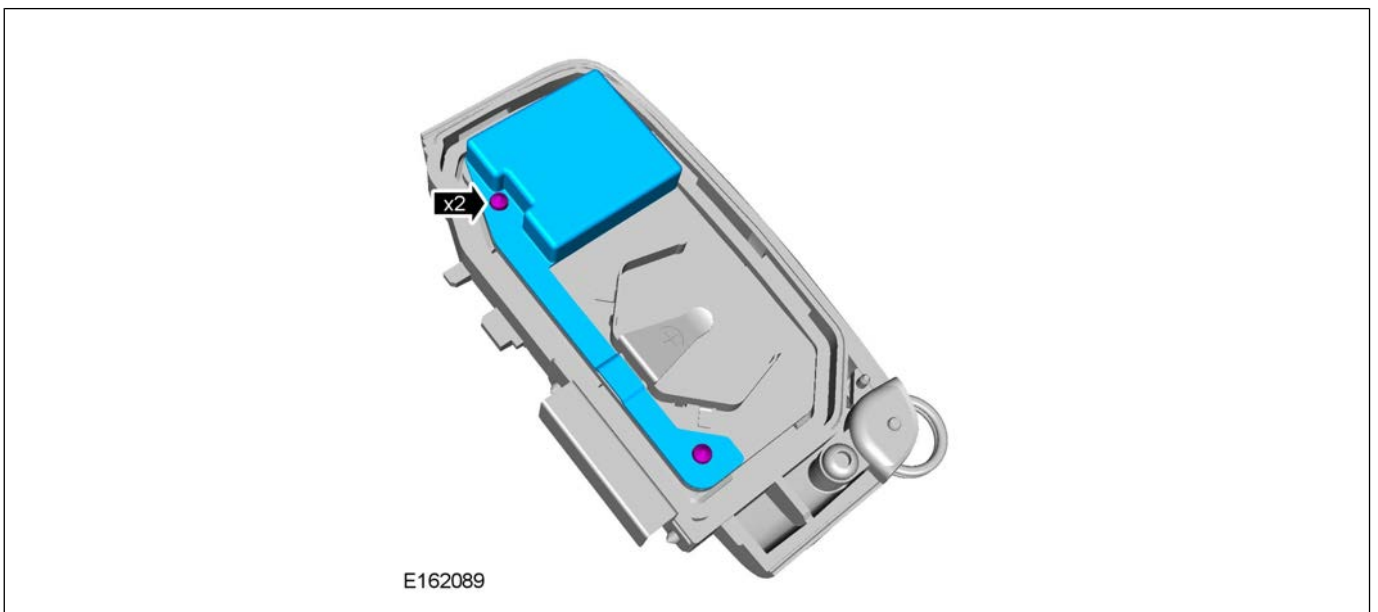

16.  NOTE: make sure the battery is installed positive (+) side **up**.

Install the battery to the upper case.

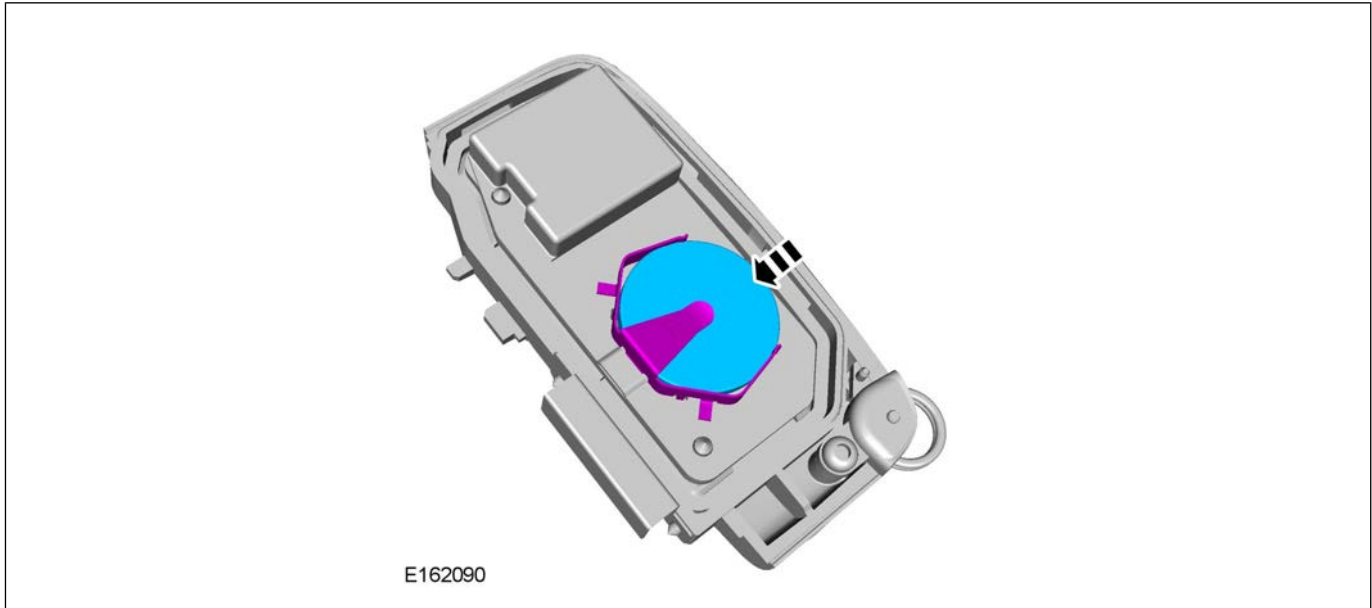

17. Install the lower case onto the handset.



18. Install the key blade.



19. Install the chrome cap.

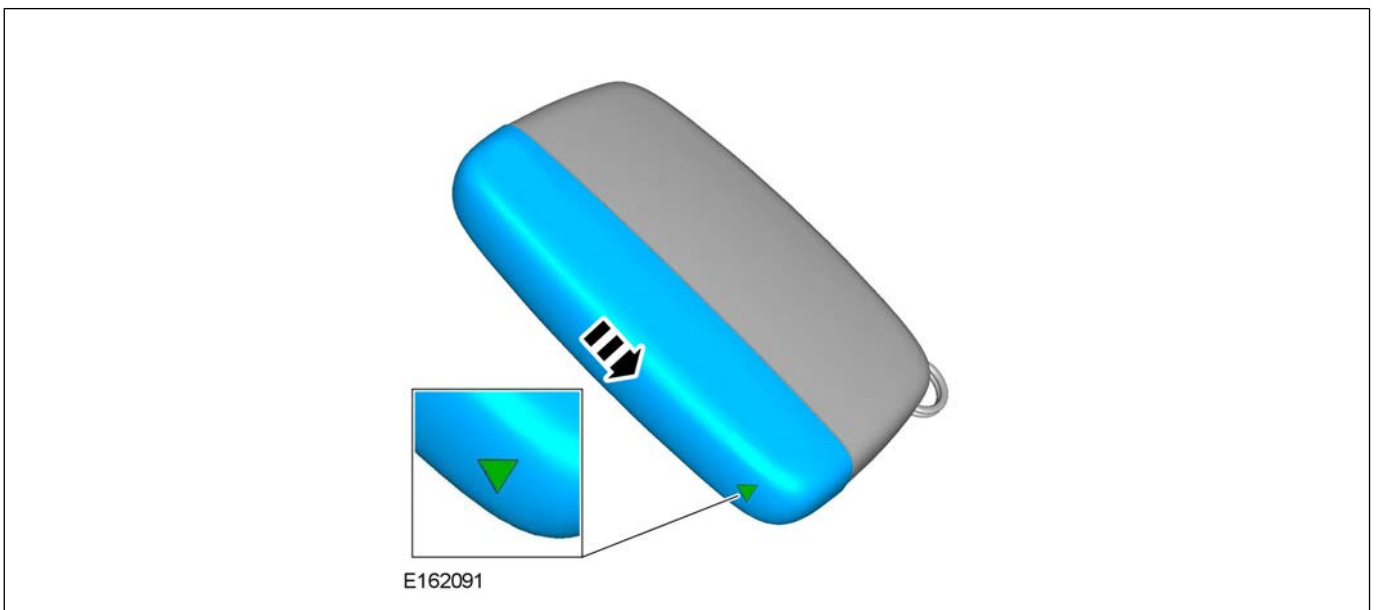

20. Check the operation of the compact key handset (all functions).

21. Perform steps 2-20 as necessary to additional compact key handsets.

12 SEP 2016

© Jaguar Land Rover North America, LLC

NOTE: The information in Technical Bulletins is intended for use by trained, professional Technicians with the knowledge, tools, and equipment required to do the job properly and safely. It informs these Technicians of conditions that may occur on some vehicles, or provides information that could assist in proper vehicle service. The procedures should not be performed by 'do-it-yourselfers'. If you are not a Retailer, do not assume that a condition described affects your vehicle. Contact an authorized Land Rover service facility to determine whether this bulletin applies to a specific vehicle.

Changes are highlighted in blue

This reissue replaces all previous versions. Please destroy all previous versions.

SECTION: 501-14

Compact Key Handset - Lower-Level Service Repair

AFFECTED VEHICLE RANGE:

LR2 (LF)

Model Year: 2013-2015
VIN: 303399-439912
Assembly Plant: Halewood

LR4 (LA)

Model Year: 2012-2016
VIN: 582668 Onwards
Assembly Plant: Solihull

Range Rover Evoque (LV)

Model Year: 2012 Onwards
VIN: 000447 Onwards
Assembly Plant: Halewood

Range Rover Sport (LW)

Model Year: 2014 Onwards
VIN: 001154 Onwards
Assembly Plant: Solihull

Range Rover (LG)

Model Year: 2013 Onwards
VIN: 001204 Onwards
Assembly Plant: Solihull

Range Rover Sport (LS)

Model Year: 2012-2013
VIN: 299939-814146
Assembly Plant: Solihull

MARKETS:

NAS

CONDITION SUMMARY:

Situation: The face of the compact key handset may peel away from the handset main body or the handset case may be bulging.

Cause: This may be caused by the handset manufacturing process.

△ **NOTE:** Replace only the affected compact key handset; it is not necessary to replace both handsets. All customer handsets must match after the conclusion of the repair.

Action: Should the customer express this concern, follow the Service Instruction outlined below.

PARTS:

△ **NOTE:** One (1) kit required per handset.

LR078922	Compact key kit (gloss finish) - LR2, LR4	1
----------	---	---

LR059383	Compact key kit (gloss finish) - Range Rover Evoque, Range Rover Sport, Range Rover	1
LR078921	Compact key kit (matte finish) - Range Rover Evoque, Range Rover Sport, Range Rover	1

WARRANTY:

△ **NOTE:** SRO time covers one (1) handset (may be used per handset repaired when applicable).

△ **NOTE:** Repair procedures are under constant review, and therefore times are subject to change; those quoted here must be taken as guidance only. Always refer to TOPIx to obtain the latest repair time.

△ **NOTE:** The JLR Claims Submission System requires the use of causal part numbers. Labor only claims must show the causal part number with a quantity of zero.

DESCRIPTION	SRO	TIME (HOURS)	CONDITION CODE	CAUSAL PART
Casing - 'Land Rover' embossed - Handset/compact key - One - Renew - LR2, LR4	86 77 36	0.1	49	LR029695
Casing - Handset/compact key - Renew - One - Range Rover Evoque, Range Rover Sport, Range Rover	86 77 36	0.1	49	LR027451

△ **NOTE:** Normal Warranty procedures apply.

SERVICE INSTRUCTION:

△ **NOTE:** Replace only the affected compact key handset; it is not necessary to replace all handsets. All customer handsets must match after the conclusion of the repair.

Step 1: Range Rover Evoque, Range Rover Sport, and Range Rover vehicles only.

1. Identify the type of compact key handset currently fitted to the vehicle to ensure a like-for-like replacement handset is fitted:

- Left = matte finish.
- Right = gloss finish.



△ **NOTE:** Refer to [SSM70798](#), 'Compact key low level repair, animation of process', to view the animation file.

2. Remove the chrome cap; place to one side.

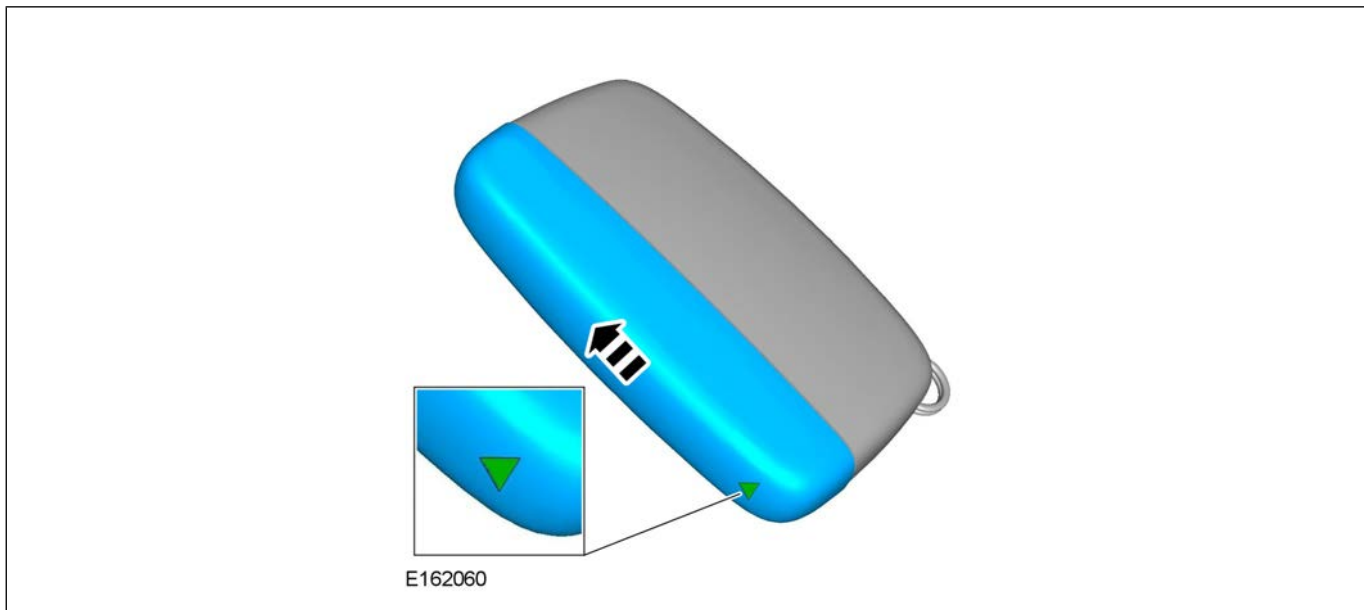

3. Remove the key blade.



4. Using the key blade, remove and discard the lower case.

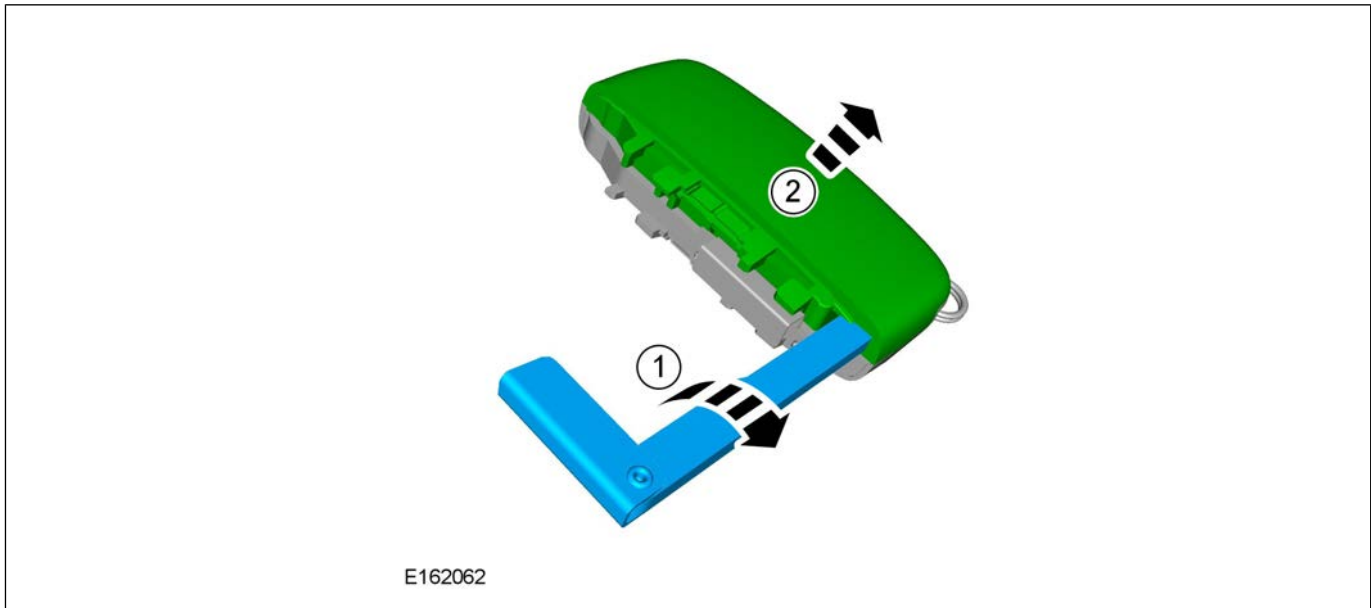

5. Remove the battery from the upper case.

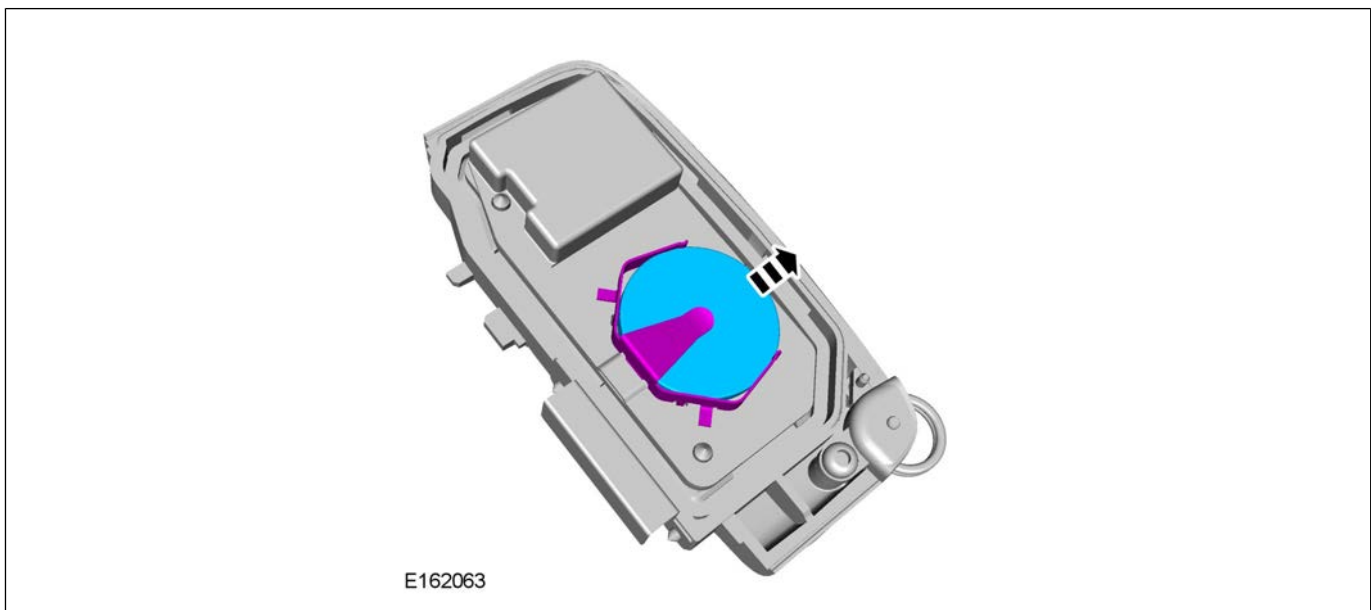

6. **⚠ CAUTION: Make sure the Printed Circuit Board (PCB) is not damaged when removing the black anti-tamper cover. If the copper coil antenna is damaged, the unit will be unserviceable.**

Using a suitable tool, cut the fixings of the black anti-tamper cover and lift away from the Printed Circuit Board (PCB).

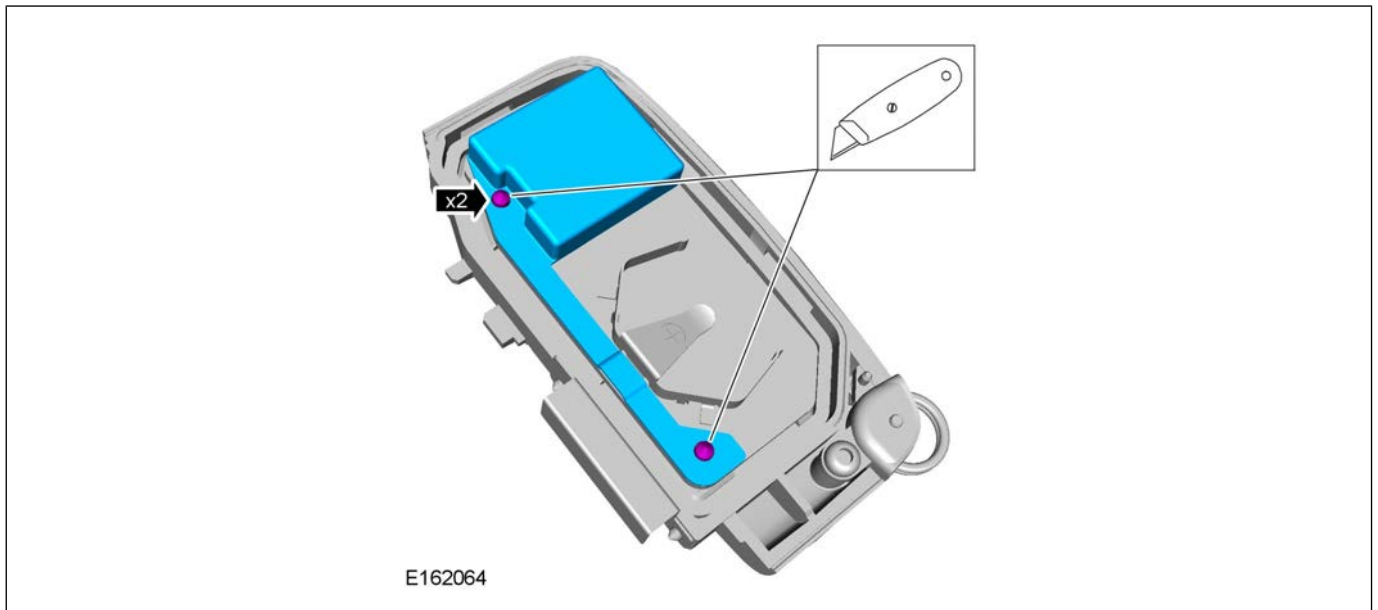

7.  **CAUTION: Handle only the outer edges of the board when removing the PCB.**

Remove the PCB; place to one side.

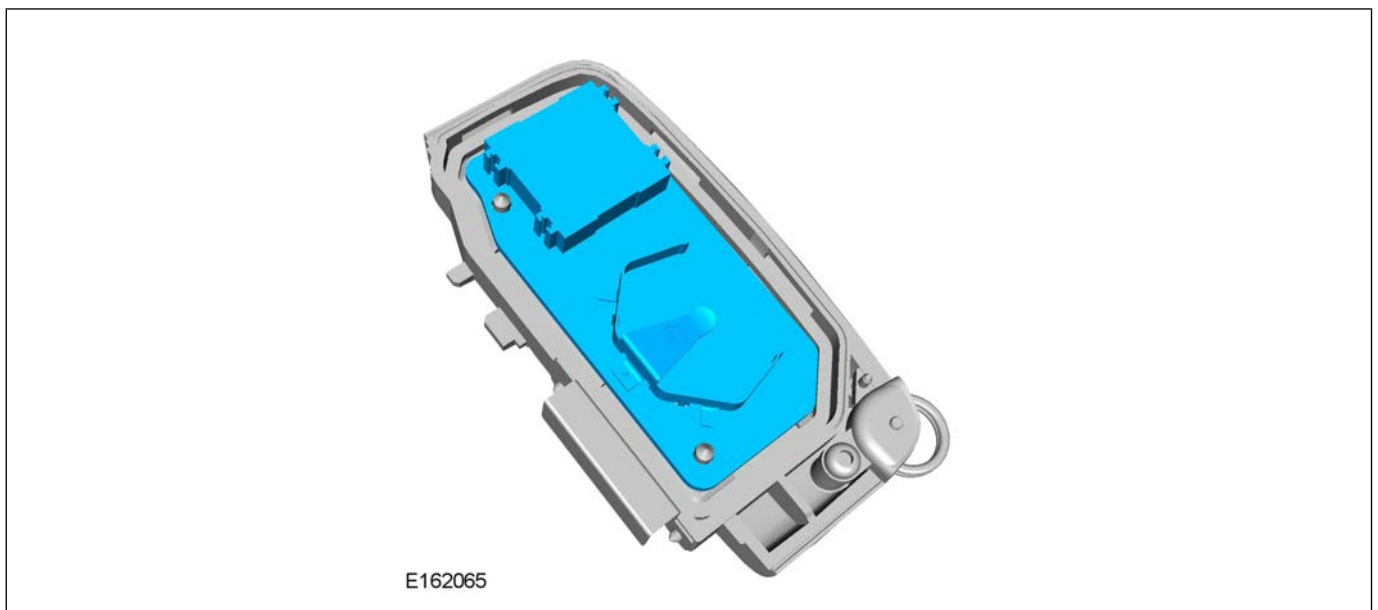

8. Remove the key ring retainer; place to one side.

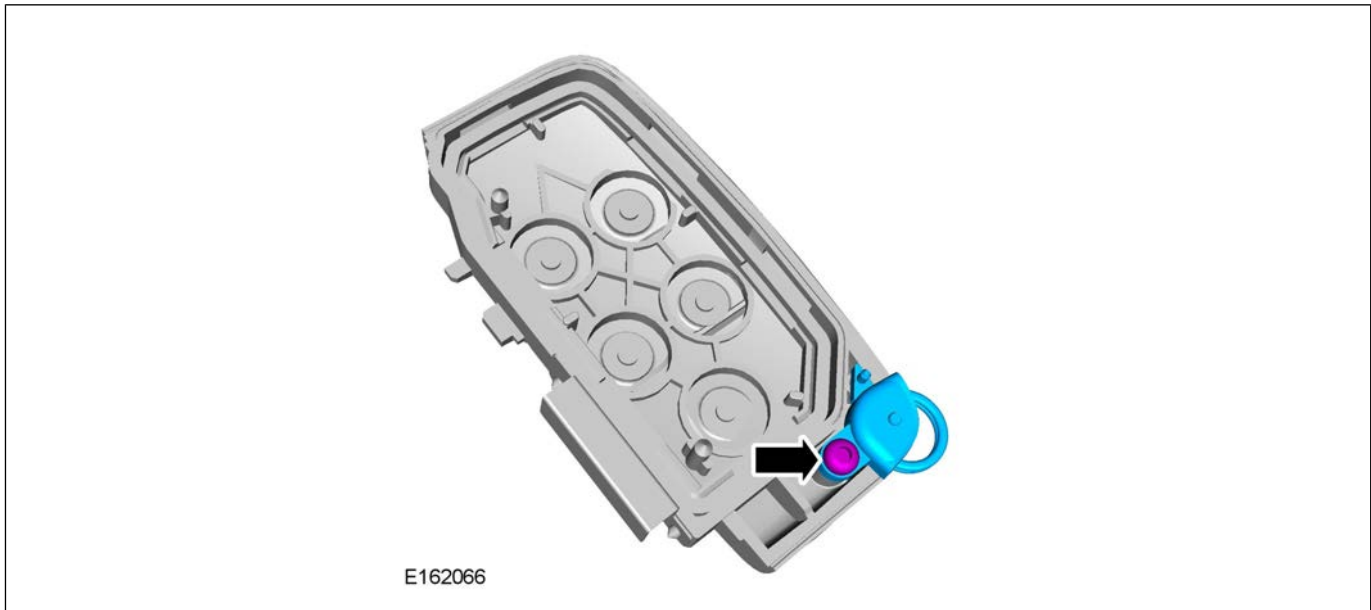

9. Remove the silicone seal from the lower case; place to one side.

- Discard the upper case.
-



10. Make sure the foam pads are installed in the lower case as shown.

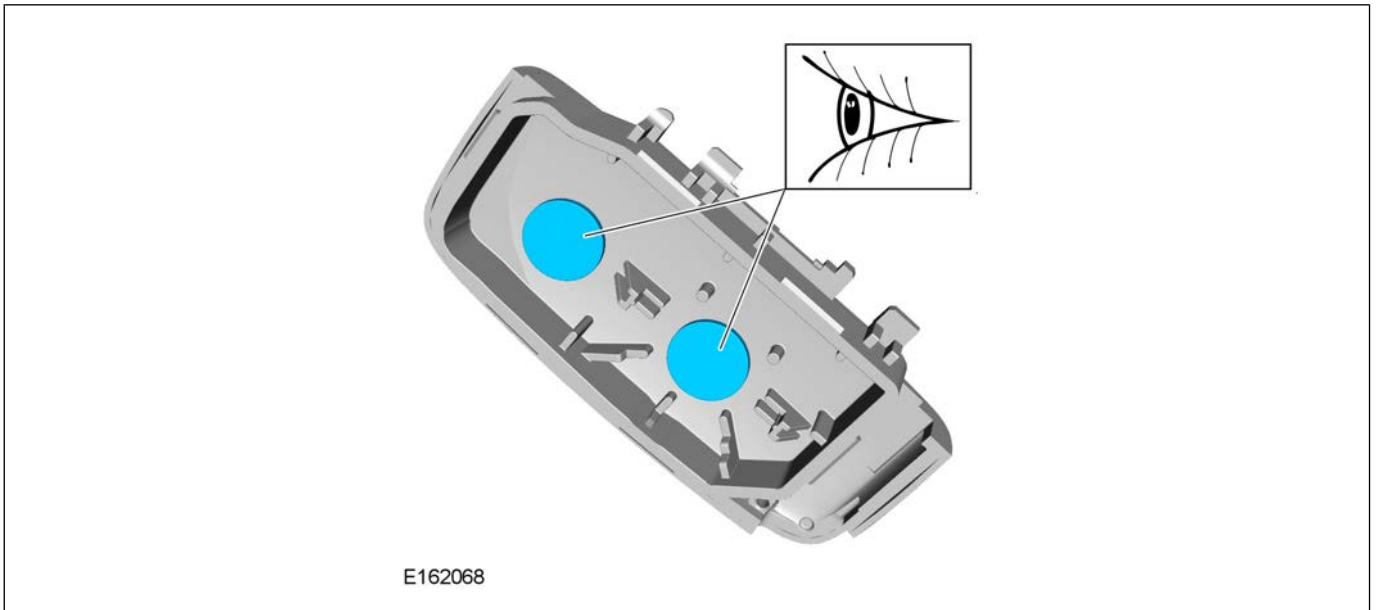

11. Install the silicone seal to the upper case.



12. Install the key ring retainer to the upper case:

- Tighten to 1Nm.

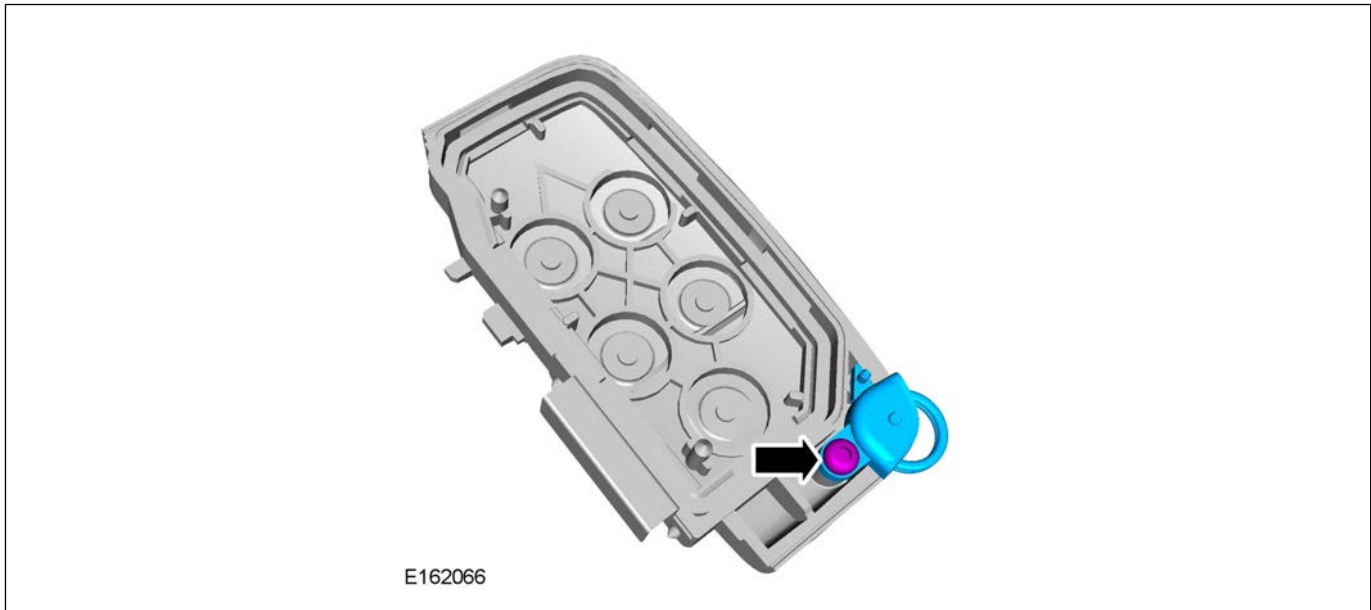

13. Make sure the key ring retaining pin is present in the upper case.



14. **⚠ CAUTION: Handle only the outer edges of the board when installing the PCB.**
△ NOTE: The PCB and cover are held in position with the foam pads on the new upper case.

Install the PCB to the upper case.

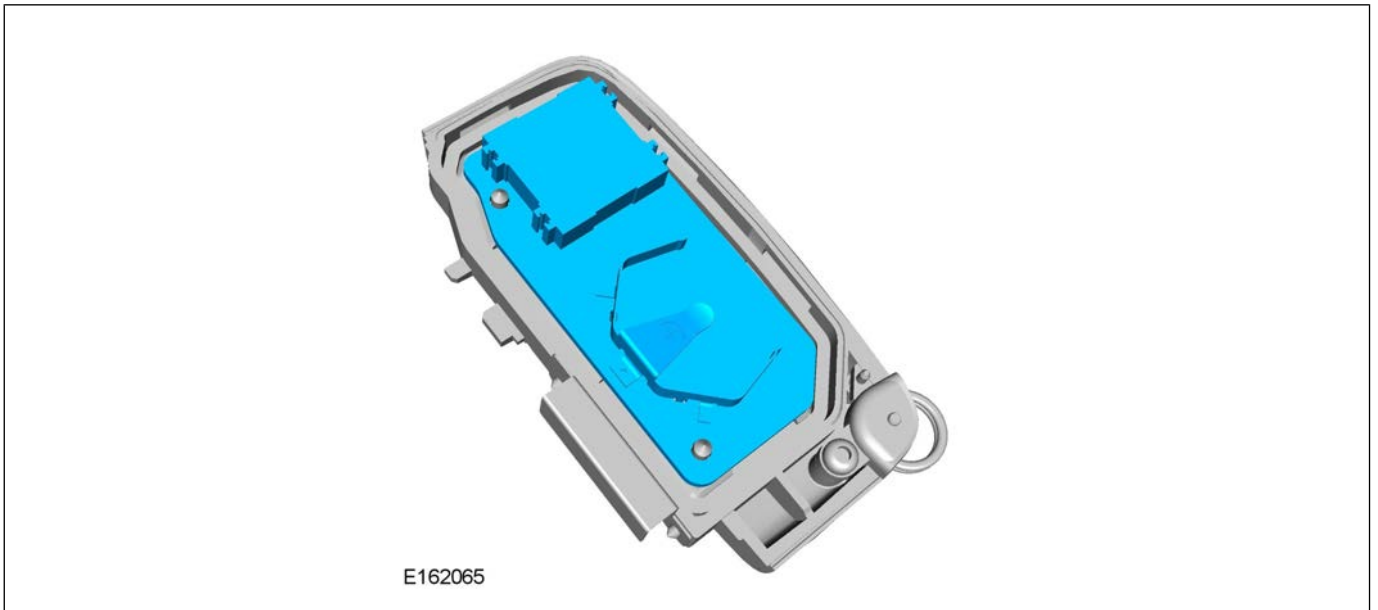

15. Install the PCB anti-tamper cover.

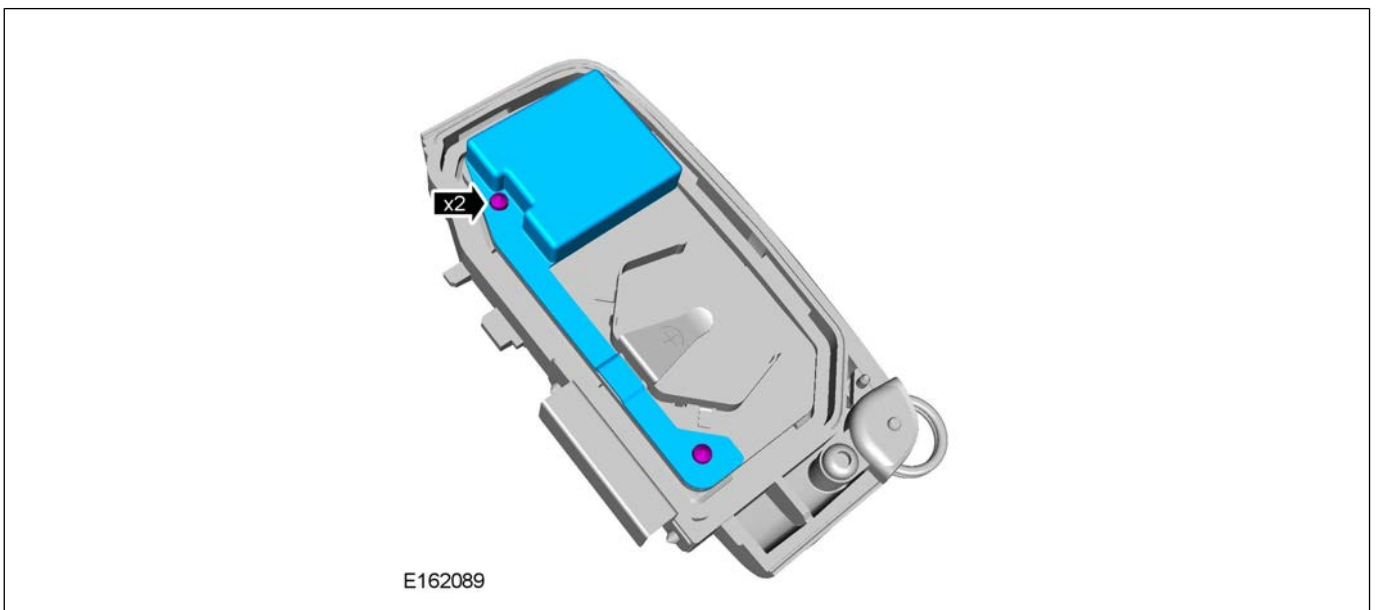

16. **△ NOTE: Make sure the battery is installed positive (+) side up.**

Install the battery to the upper case.

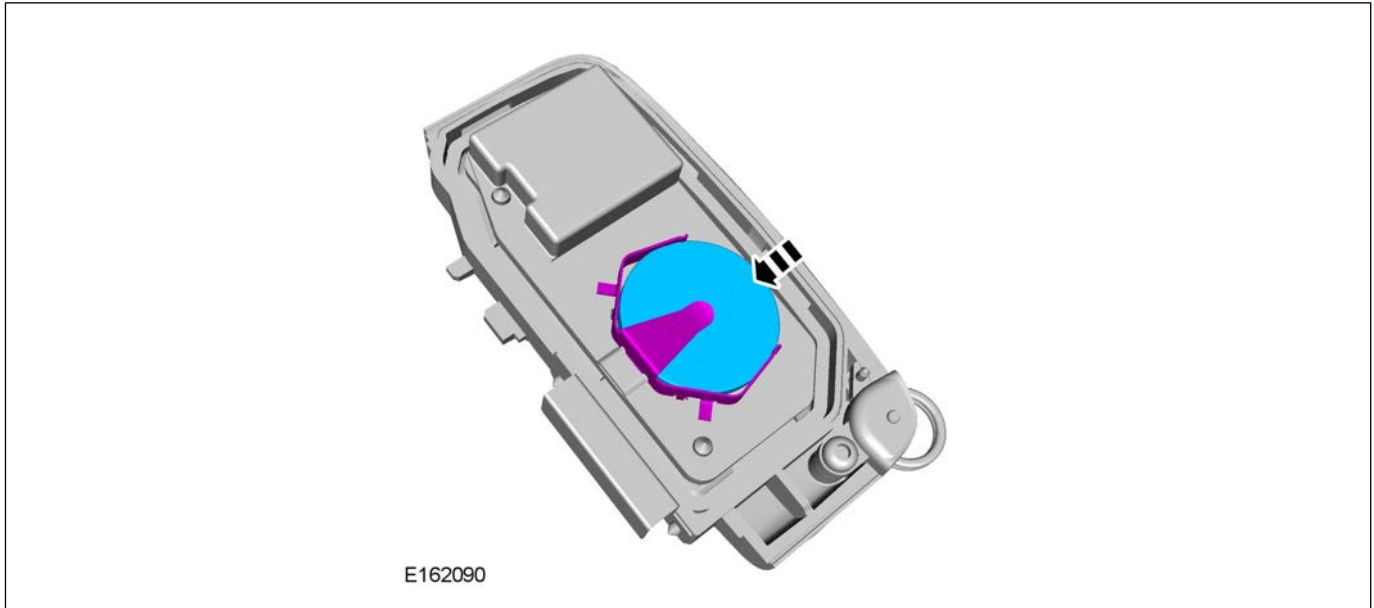

17. Install the lower case onto the handset.



18. Install the key blade.



19. Install the chrome cap.

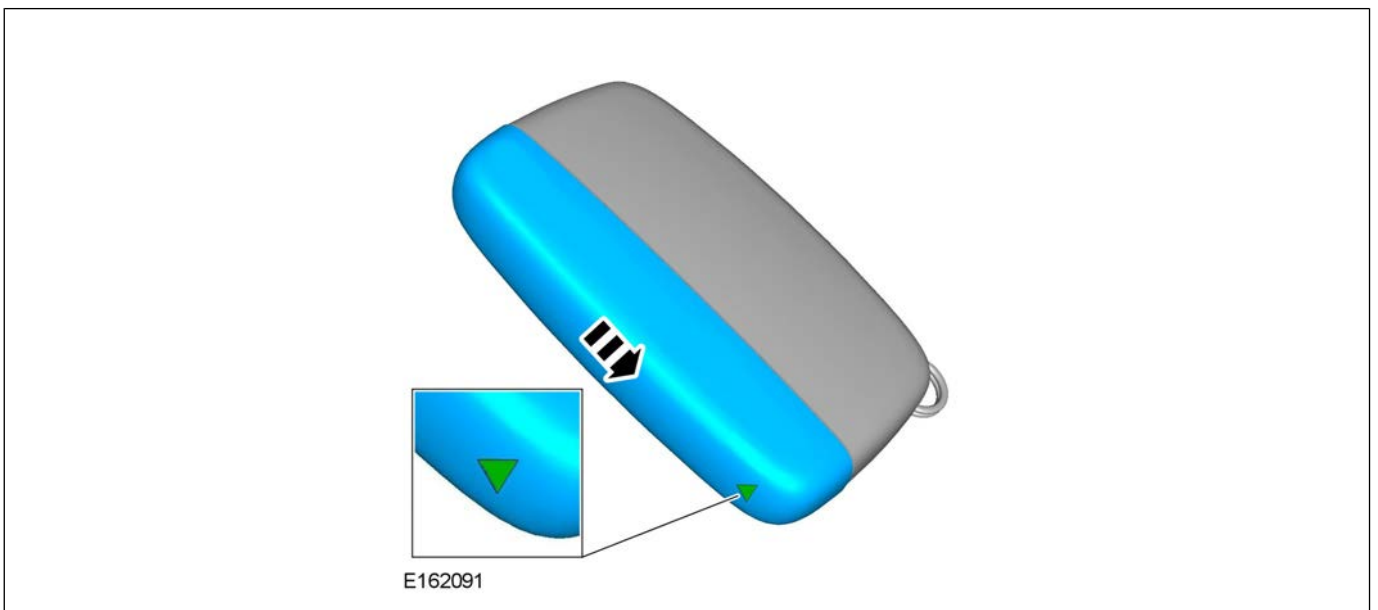

20. Check the operation of the compact key handset (all functions).

21. Perform steps 2-20 as necessary to additional compact key handsets.

TECHNICAL BULLETIN

LTB00699NAS1



06 OCT 2014

© Jaguar Land Rover North America, LLC

NOTE: The information in Technical Bulletins is intended for use by trained, professional Technicians with the knowledge, tools, and equipment required to do the job properly and safely. It informs these Technicians of conditions that may occur on some vehicles, or provides information that could assist in proper vehicle service. The procedures should not be performed by 'do-it-yourselfers'. If you are not a Retailer, do not assume that a condition described affects your vehicle. Contact an authorized Land Rover service facility to determine whether this bulletin applies to a specific vehicle.

SECTION: 501-03

Rear Door Soft Close Feature Inoperative

AFFECTED VEHICLE RANGE:

Range Rover (LG)

Model Year:2013-2014

VIN: DA100000-EA180780

MARKETS:

NAS

CONDITION SUMMARY:

Situation: The rear door soft close feature may be inoperative.

Cause: This may be caused by insufficient back pressure from door sealing system.

Action: Should a customer express this concern, follow the Service Instruction outlined below.

PARTS:

LR066092	Plunger Collar	2
LR066080	Plunger Spring	2
LR066088	Clear Patch - Left	1
LR066087	Clear Patch - Right	1
LR066376	Fixing Screw	2

TOOLS:

△ NOTE: Aluminum-only or new, previously unused, drill bits must be used.

IMAGE NOT AVAILABLE	4.2mm aluminum-only drill bit 13mm aluminum-only drill bit
---------------------	---

WARRANTY:

△ NOTE: Repair procedures are under constant review, and therefore times are subject to change; those quoted here must be taken as guidance only. Always refer to TOPIx to obtain the latest repair time.

△ NOTE: The JLR Claims Submission System requires the use of causal part numbers. Labor only claims must show the causal part number with a quantity of zero.

DESCRIPTION	SRO	TIME (HOURS)	CONDITION CODE	CAUSAL PART
Rear door soft close assemblies - Install	76.40.89.43	0.3	42	LR048263/4

△ NOTE: Normal Warranty procedures apply.

SERVICE INSTRUCTION:

△ NOTE: The Pre-Delivery Inspection (PDI) must be completed.

△ NOTE: Refer to SSM71992 for the soft close assembly drilling template.

△ NOTE: All illustrations: rear right-hand door shown; rear left-hand door similar.

1. Verify right-hand rear door soft close operation by slowly closing the door and engaging only the first portion of the door latch.
 - If the door 'soft' closes (door automatically pulled in to the fully-closed position), continue to the next step.
 - If the door does not 'soft' close (door not automatically pulled in to the fully-closed position), diagnose and repair as a separate claim.
 - Repeat for left-hand rear door.
2. Open the rear right-hand door.
3. Using a suitable cloth, clean the door area as shown.



E168910

4. Position the template to the rear door.

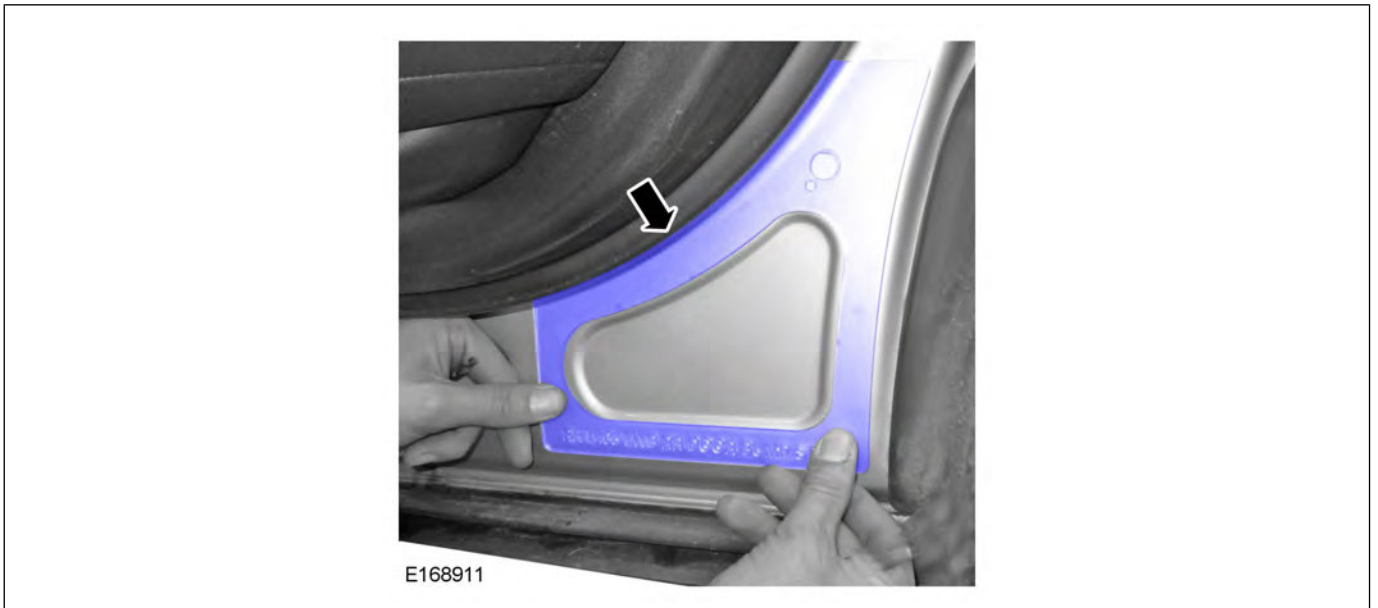

5.  NOTE: Cleanliness is important to avoid galvanic corrosion.

 NOTE: Use a new or aluminum-only drill bit as required to avoid galvanic corrosion.

Using a suitable marker, mark the center of both holes.

- Using a suitable new or aluminum-only 13mm and 4.2mm drill bit, drill both holes as marked.

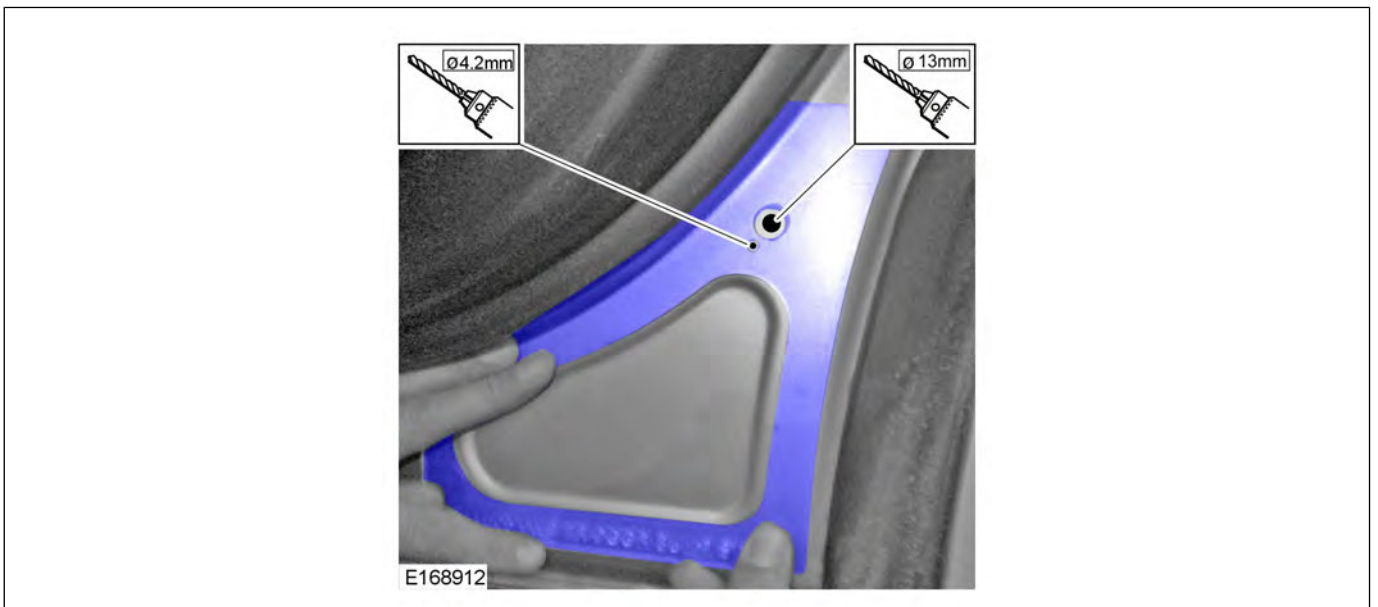

6.  CAUTION: Make sure to drill only the inner skin.

Remove any burrs from drilled holes.

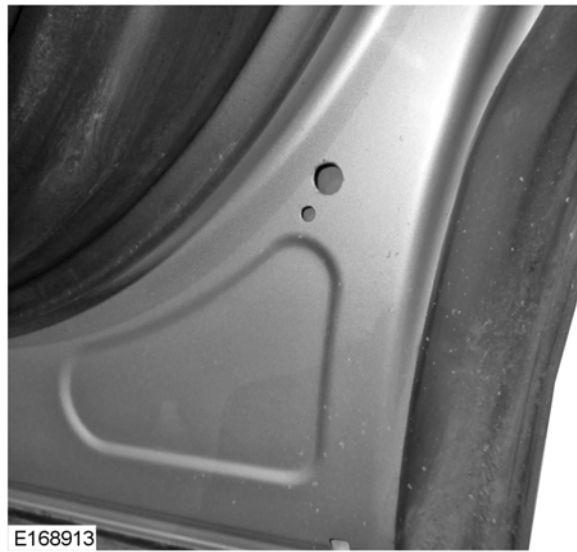

7. Peel back and discard the plastic strip from the plunger collar.





8. Install the plunger collar to the rear door.

- Install the fixing screw.

- Torque: 3.5Nm



9.  NOTE: Make sure to align the two sections using the keyway.
-  NOTE: An audible click will be heard when the two parts are fitted correctly.
- Install the plunger spring to the plunger collar.



10. Apply water to the tip of the buffer.

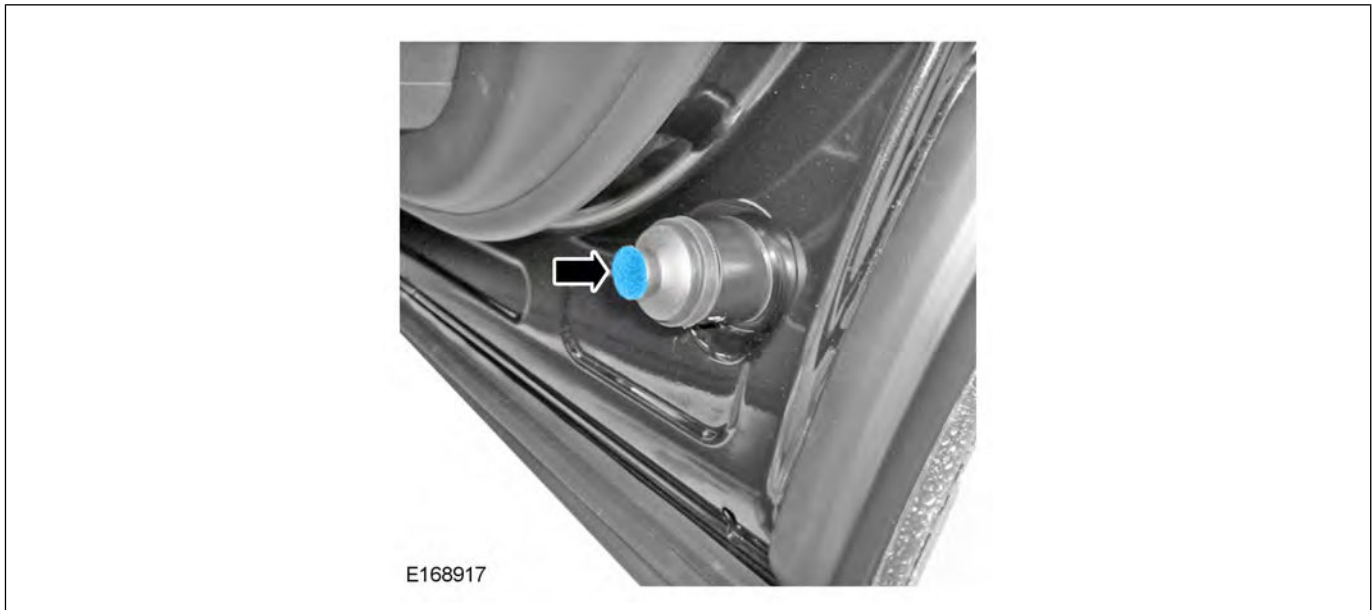

11. Gently close the door and observe the water witness mark on the 'C' pillar.



12. Place the clear patch into a cap of water.

- Install the clear patch directly over the water witness mark.

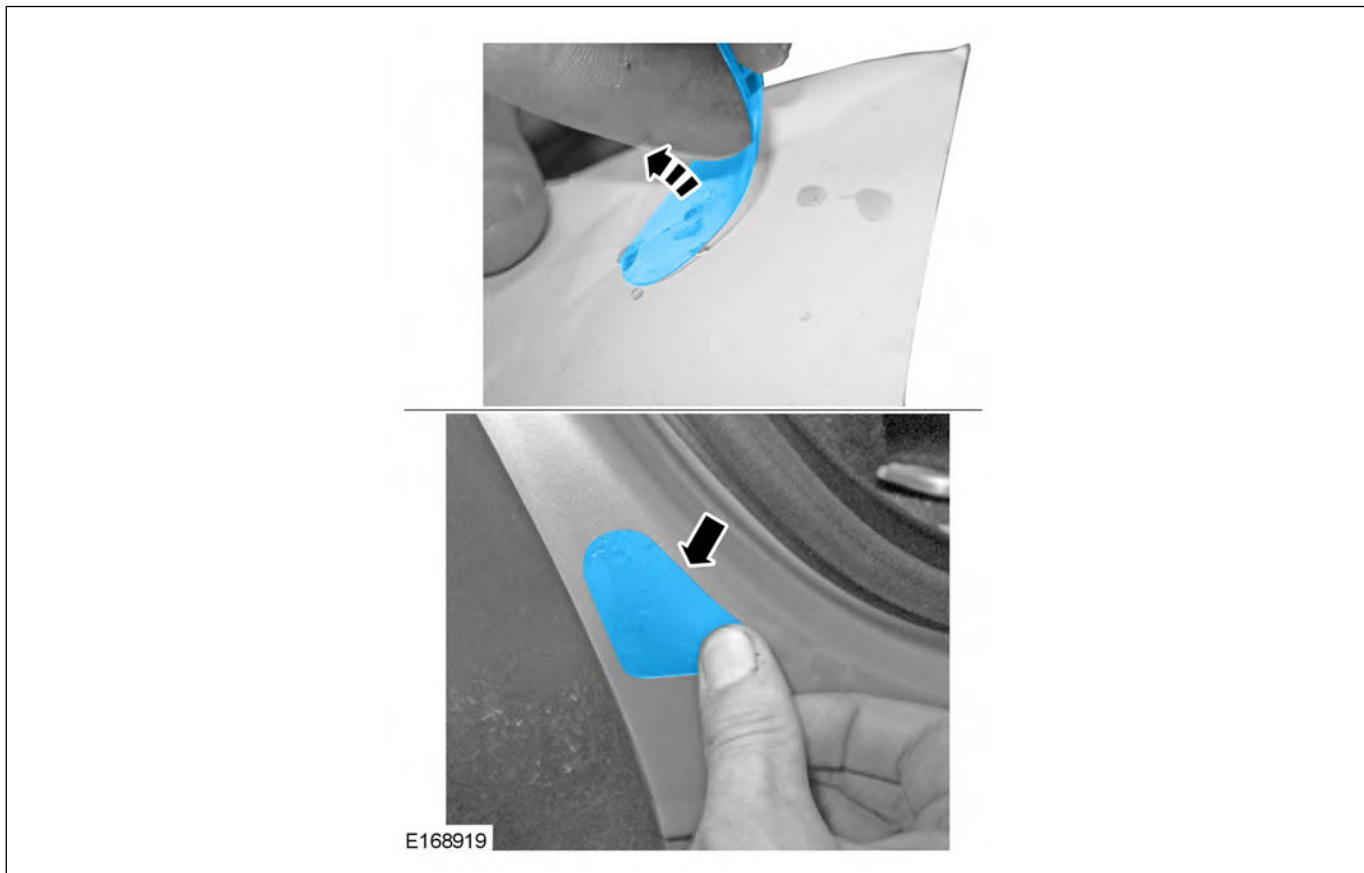

13. Using a suitable card firmly smooth out the pad to remove any air bubbles.

- Using a suitable dry cloth, wipe the area down.

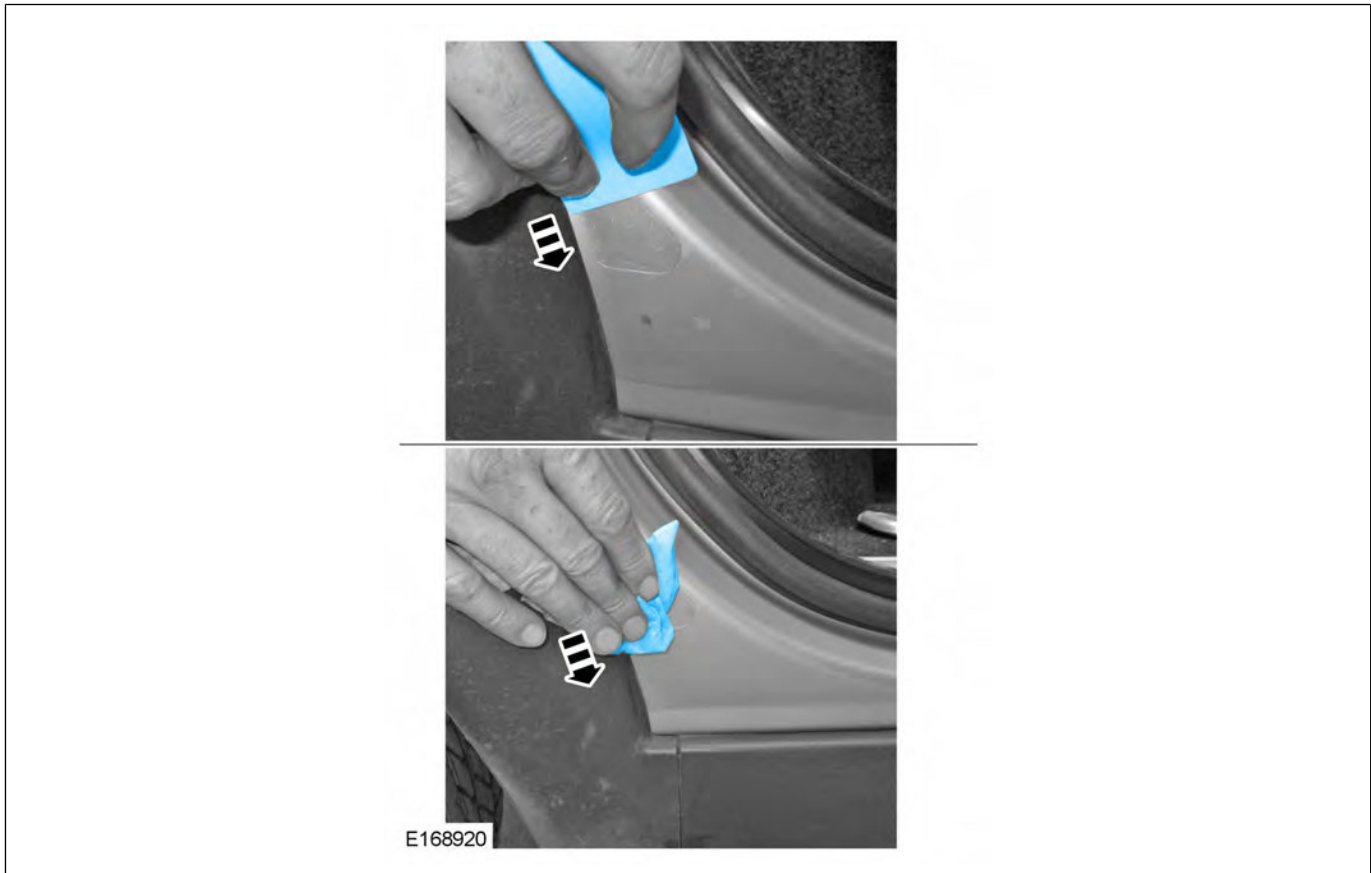

14. Check the rear door soft close feature operation.
15. Repeat steps 1-13 to the rear left-hand door.

TECHNICAL BULLETIN

LTB00699NAS2



08 APR 2015

© Jaguar Land Rover North America, LLC

NOTE: The information in Technical Bulletins is intended for use by trained, professional Technicians with the knowledge, tools, and equipment required to do the job properly and safely. It informs these Technicians of conditions that may occur on some vehicles, or provides information that could assist in proper vehicle service. The procedures should not be performed by 'do-it-yourselfers'. If you are not a Retailer, do not assume that a condition described affects your vehicle. Contact an authorized Land Rover service facility to determine whether this bulletin applies to a specific vehicle.

Changes are highlighted in blue

This reissue replaces all previous versions. Please destroy all previous versions.

SECTION: 501-03

Rear Door Soft Close Feature Inoperative

AFFECTED VEHICLE RANGE:

Range Rover (LG)

Model Year:2013-2014

VIN: DA001204-EA180780

MARKETS:

NAS

CONDITION SUMMARY:

Situation: The rear door soft close feature may be inoperative.

Cause: This may be caused by insufficient back pressure from door sealing system.

Action: Should a customer express this concern, follow the Service Instruction outlined below.

PARTS:

LR066092	Plunger collar - Non-tapered	2
LR066091	Plunger collar - Tapered	2
LR066080	Plunger spring	2
LR066088	Clear patch - Left	1
LR066087	Clear patch - Right	1
LR066376	Fixing screw	2

TOOLS:

△ NOTE: aluminum-only or new, previously unused, drill bits must be used.

IMAGE NOT AVAILABLE	4.2mm aluminum-only drill bit 13mm aluminum-only drill bit
---------------------	---

WARRANTY:

△ NOTE: Repair procedures are under constant review, and therefore times are subject to change; those quoted here must be taken as guidance only. Always refer to TOPIx to obtain the latest repair time.

△ NOTE: The JLR Claims Submission System requires the use of causal part numbers. Labor only claims must show the causal part number with a quantity of zero.

DESCRIPTION	SRO	TIME (HOURS)	CONDITION CODE	CAUSAL PART
Rear door soft close assemblies - Install	76.40.89.43	0.3	42	LR048263/4

△ **NOTE:** Normal Warranty procedures apply.

SERVICE INSTRUCTION:

△ **NOTE:** the Pre-Delivery Inspection (PDI) must be completed.

△ **NOTE:** refer to SSM71992 for the soft close assembly drilling template.

△ **NOTE:** all illustrations: rear right-hand door shown; rear left-hand door similar.

1. Check the rear door pressing to determine which plunger collar must be used in the following Service Instruction. If the door pressing is as picture 'A', then install the tapered plunger collar (LR066091). If the door pressing is as picture 'B', then install the non-tapered plunger collar (LR066092).

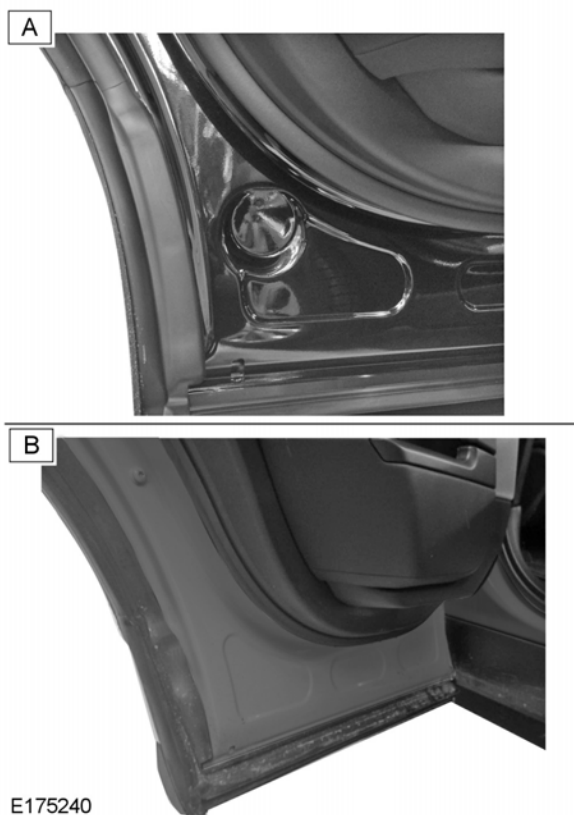

2. Open the rear right-hand door.

3. Using a suitable cloth, clean the door area as shown.

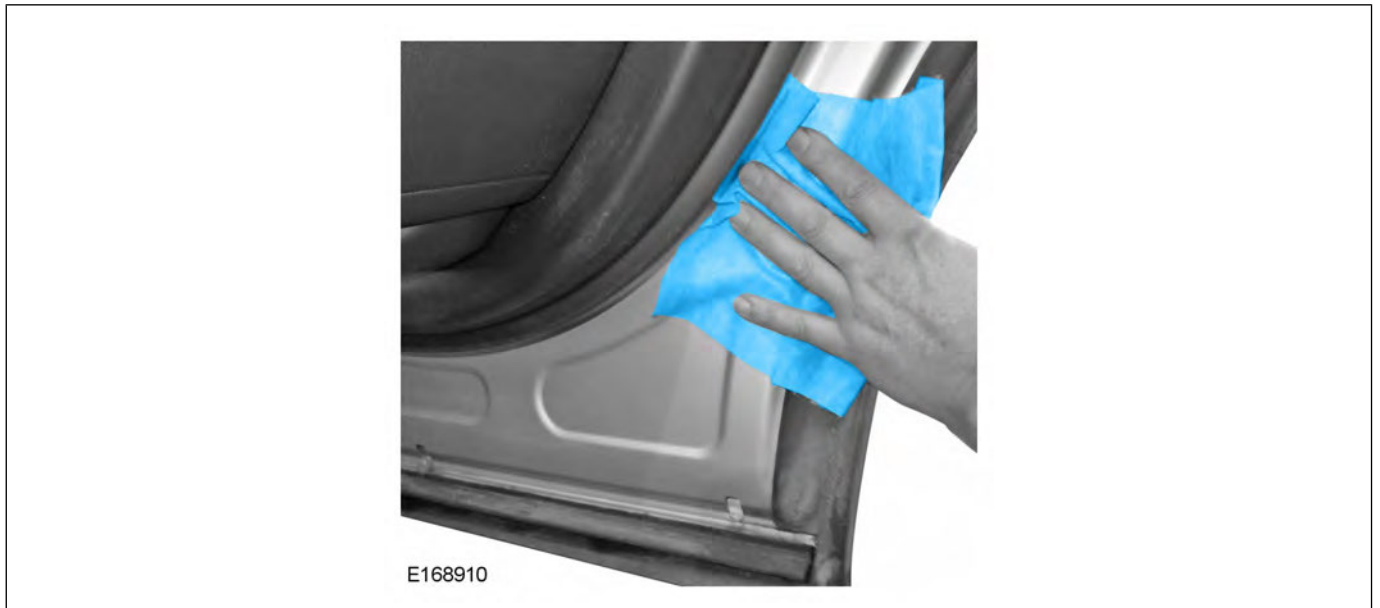

4. Position the template to the rear door.

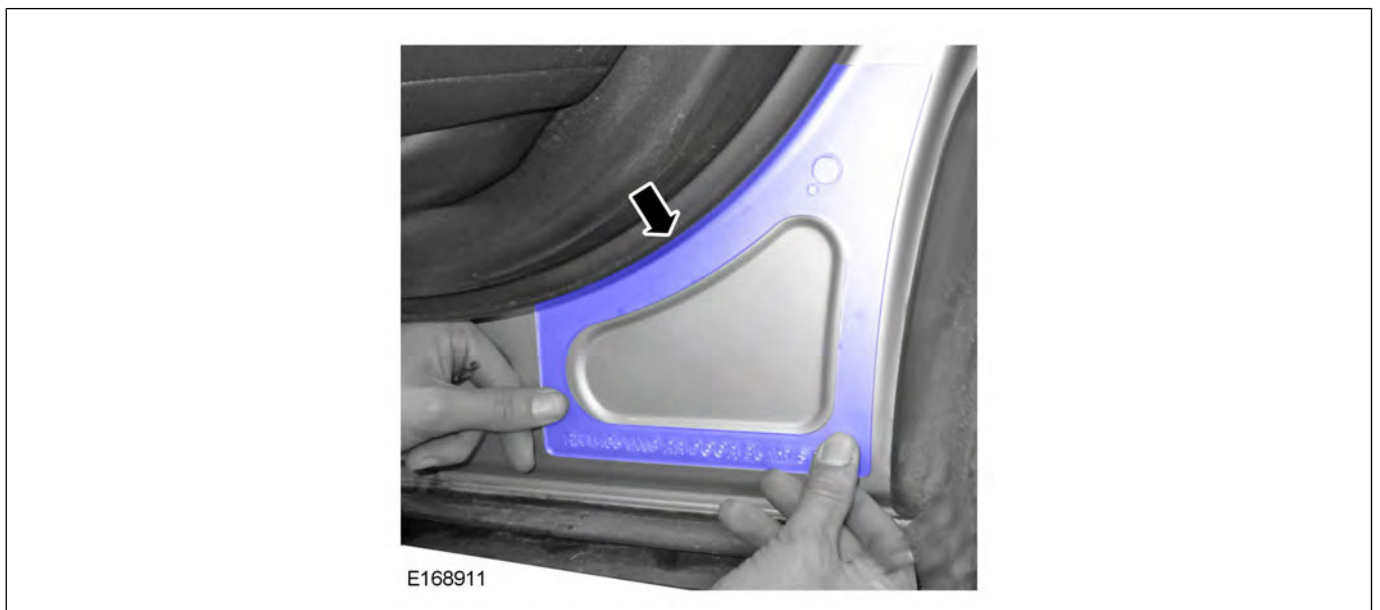

5. **△ NOTE: cleanliness is important to avoid galvanic corrosion.**
△ NOTE: use a new or aluminum-only drill bit as required to avoid galvanic corrosion.
Using a suitable marker, mark the center of both holes.

- Using a suitable new or aluminum-only 13mm and 4.2mm drill bit, drill both holes as marked.

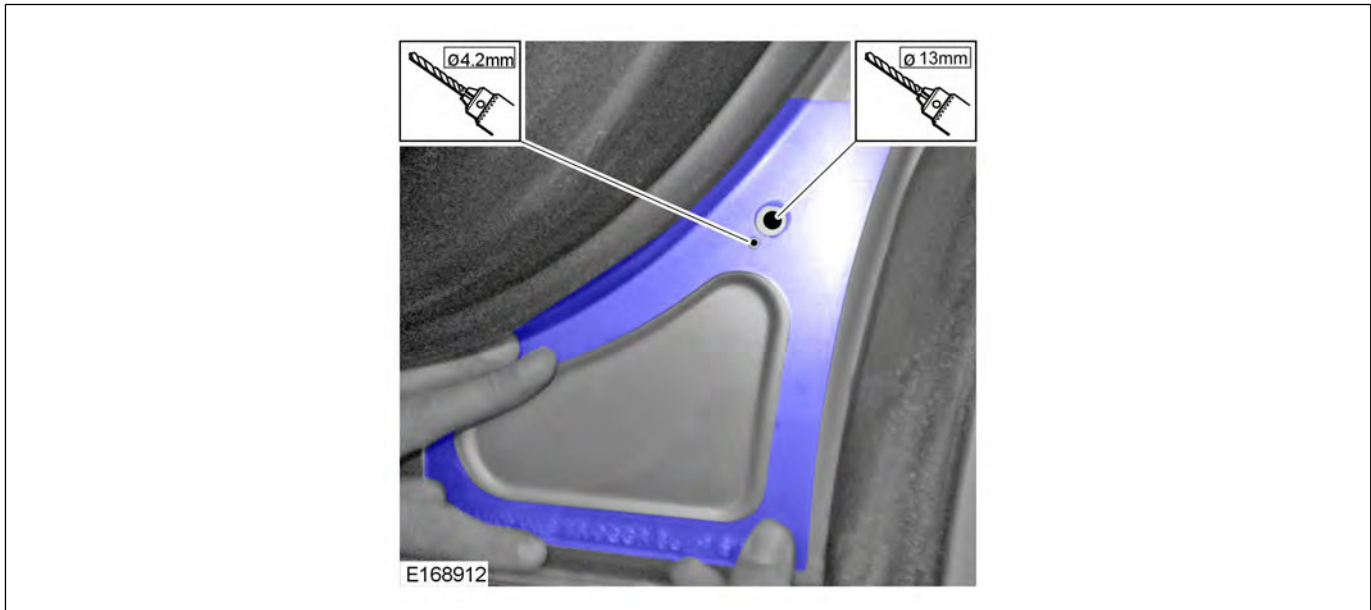

6.  CAUTION: \make sure to drill only the inner skin.

Remove any burrs from drilled holes.

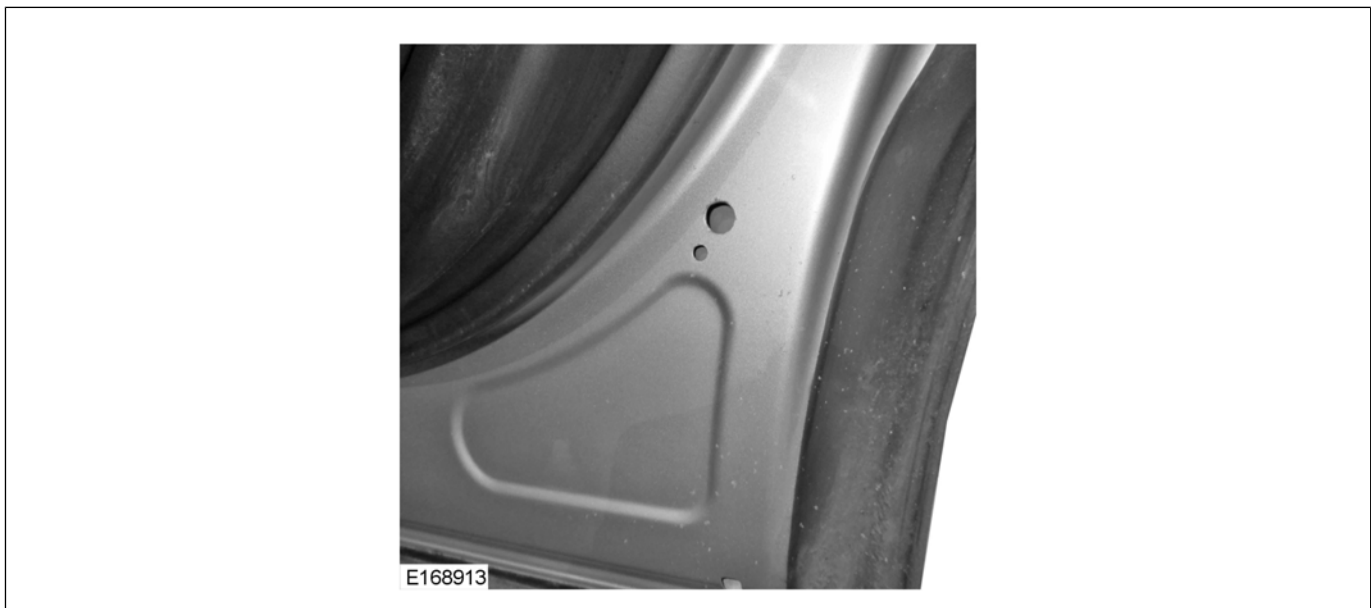

7. Peel back and discard the plastic strip from the plunger collar.



8. **△ NOTE:** install the correct plunger as identified in step 1.

Install the plunger collar to the rear door.

- Install the fixing screw.
- Torque: 3.5Nm



9. **△ NOTE:** make sure to align the two sections using the keyway.

△ NOTE: an audible click will be heard when the two parts are fitted correctly.

Install the plunger spring to the plunger collar.



E168916

10. Apply water to the tip of the buffer.



E168917

11. Gently close the door and observe the water witness mark on the 'C' pillar.



12. Place the clear patch into a cap of water.

- Install the clear patch directly over the water witness mark.

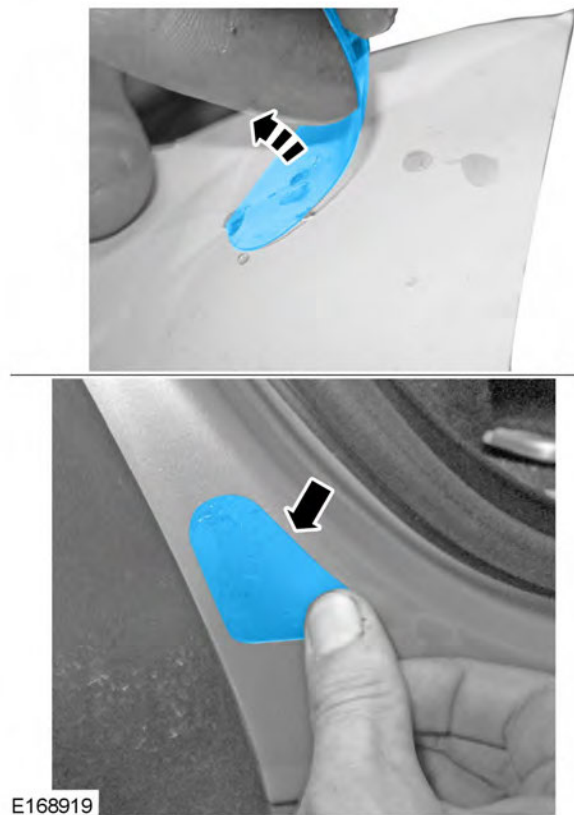

13. Using a suitable card firmly smooth out the pad to remove any air bubbles.

- Using a suitable dry cloth, wipe the area down.

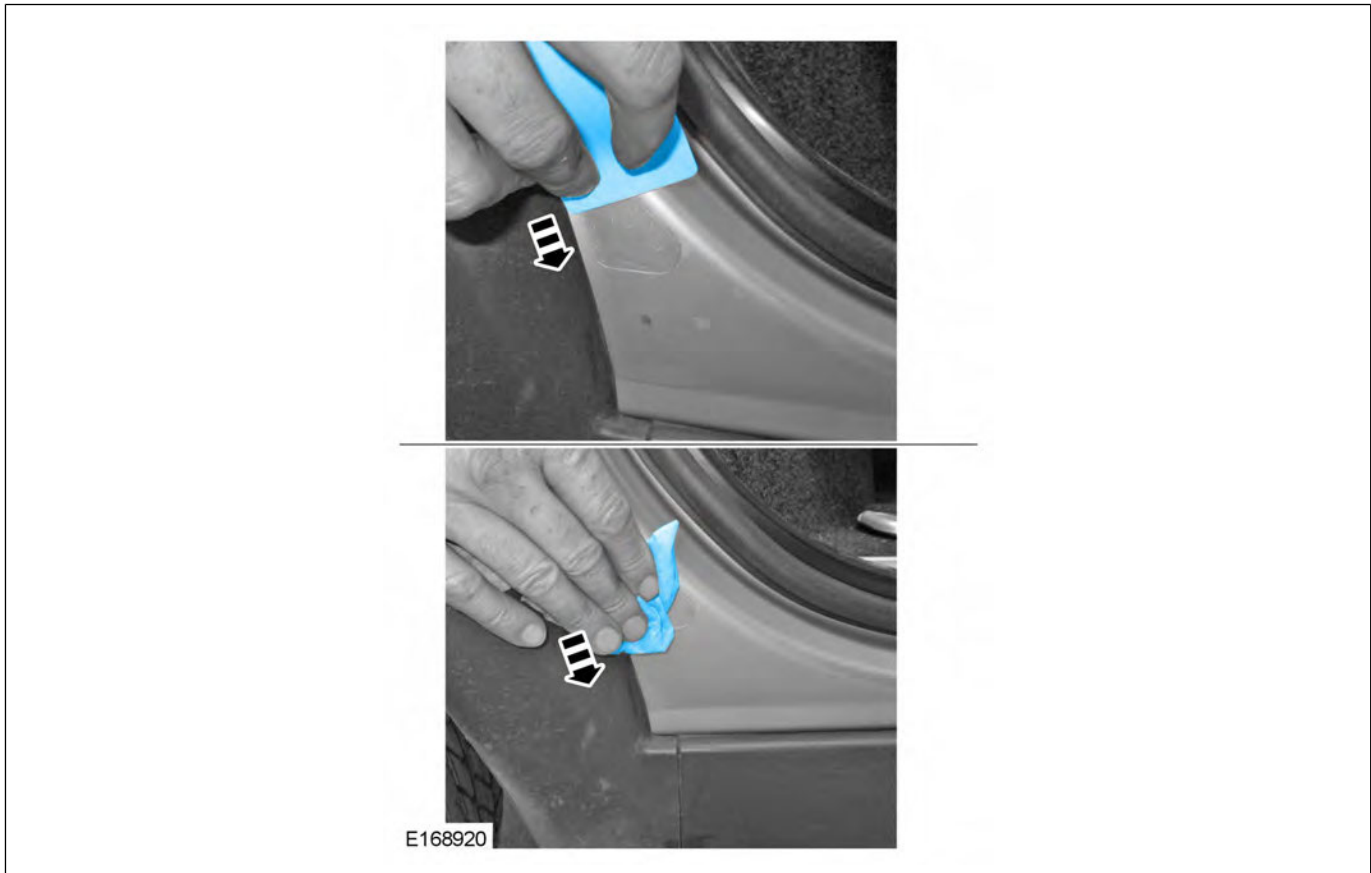

14. Check the rear door soft close feature operation.
15. Repeat steps 1-14 to the rear left-hand door.



LTB00816NAS1

TECHNICAL BULLETIN

05 OCT 2015

© Jaguar Land Rover North America, LLC

NOTE: The information in Technical Bulletins is intended for use by trained, professional Technicians with the knowledge, tools, and equipment required to do the job properly and safely. It informs these Technicians of conditions that may occur on some vehicles, or provides information that could assist in proper vehicle service. The procedures should not be performed by 'do-it-yourselfers'. If you are not a Retailer, do not assume that a condition described affects your vehicle. Contact an authorized Land Rover service facility to determine whether this bulletin applies to a specific vehicle.

INFORMATION

SECTION:

419-00

SUBJECT/CONCERN:

Central Door Locking Inoperative At PDI

AFFECTED VEHICLE RANGE:

MODEL:	MODEL YEAR:	VIN:	ASSEMBLY PLANT:
LR4 (LA)	2015 Onwards	731301 Onwards	Solihull
Range Rover Sport (LW)	2015 Onwards	504511 Onwards	Solihull
Range Rover (LG)	2015 Onwards	197042 Onwards	Solihull

MARKETS:

NAS

CONDITION SUMMARY:**SITUATION:**

After removing a vehicle from Transit Mode as part of the Pre-Delivery Inspection (PDI), Central Door Locking (CDL) issues with one or more doors (but not the tailgate[s]) may be evident.

CAUSE:

This may be caused by an incorrect door module configuration during the vehicle manufacture.

ACTION:

Should this concern occur at PDI, follow the Service Instruction outlined below.

PARTS:

No Parts Required

TOOLS:**NOTE:**

this 'Active Bulletin' will display a functional programming shortcut if accessed within a diagnostic session using SDD.

	SDD with latest DVD and Calibration File		Jaguar Land Rover-approved Midtronics battery power supply
--	--	--	--

WARRANTY:

NOTES:

- Repair procedures are under constant review, and therefore times are subject to change; those quoted here must be taken as guidance only. Always refer to TOPIx to obtain the latest repair time.
- The JLR Claims Submission System requires the use of causal part numbers. Labor only claims must show the causal part number with a quantity of zero

DESCRIPTION	SRO	TIME (HOURS)	CONDITION CODE	CAUSAL PART
Drivers door module - Configure	86.90.81	0.3	42	LR072197
Passenger door module - Configure	86.90.82	0.3	42	LR072197
Passenger door module - Configure - with diagnostic equipment connected	86.90.81.01	0.2	42	LR072197

NOTE:

Normal Warranty procedures apply.

SERVICE INSTRUCTION:

ⓘ CAUTIONS:

- a Jaguar Land Rover-approved Midtronics battery power supply must be connected to the vehicle battery during SDD diagnosis / module programming.
- ensure all ignition 'ON' / ignition 'OFF' requests are carried out; failure to perform these steps may cause damage to control modules in the vehicle.

⚠ NOTE:

SDD must be loaded with DVD142.04 v.213 or later.

- 1 Connect the Jaguar Land Rover-approved Midtronics battery power supply to the vehicle battery.
- 2 Turn ignition 'ON' (engine not running).
- 3 Connect the Symptom Driven Diagnostics (SDD) system to the vehicle and begin a new session.
- 4 Follow the on-screen prompts, allowing SDD to read the VIN and identify the vehicle and initiating the data collect sequence.
- 5 Select 'Service Functions' from the Session Type screen.
- 6 Select 'continue'.
- 7 Select the 'Recommendations' tab, and then select '**Run**' to perform the 'Configure new module - Driver's door module' option.

OR

- 8 Select 'Service Functions' from the Session Type screen.

- 9 Select 'continue'.

- 10 Select the 'Recommendations' tab, and then select '**Run**' to perform the 'Configure new module - Passenger's door module' option.

- 11 Follow all on-screen instructions to complete this task, ensuring all DTCs are cleared.

- 12 Exit the current session.

- 13 Disconnect the SDD and the battery power supply from the vehicle.

LTB00845NAS1

TECHNICAL BULLETIN

11 NOV 2015



A JAGUAR COMPANY

© Jaguar Land Rover North America, LLC

NOTE: The information in Technical Bulletins is intended for use by trained, professional Technicians with the knowledge, tools, and equipment required to do the job properly and safely. It informs these Technicians of conditions that may occur on some vehicles, or provides information that could assist in proper vehicle service. The procedures should not be performed by 'do-it-yourselfers'. If you are not a Retailer, do not assume that a condition described affects your vehicle. Contact an authorized Land Rover service facility to determine whether this bulletin applies to a specific vehicle.

INFORMATION

SECTION:

418-00

SUBJECT/CONCERN:

Smart Key Does Not Unlock the Vehicle

AFFECTED VEHICLE RANGE:

MODEL:	MODEL YEAR:	VIN:	ASSEMBLY PLANT:
Range Rover Sport (LW)	2014-2015	001154-542164	Solihull
Range Rover Sport (LW)	2015	601763-630153	Solihull
Range Rover (LG)	2013-2015	001204-243370	Solihull

MARKETS:

NAS

CONDITION SUMMARY:**SITUATION:**

The vehicle may not unlock when using the Smart Key. Upon further diagnosis, the Technician may find one or more of the following vehicle symptoms:

- Low or high resistance on both MS CAN lines.
- Permanent or intermittent failures of the MS CAN.
- Permanent or intermittent issue with the window switch operation.
- Permanent or intermittent issue with the key fob (unable to unlock vehicle).
- Permanent or intermittent charging system faults.

 **NOTE:**

the condition is normally only present on vehicles that are NOT fitted with a rear seat module.

CAUSE:

This may be caused by corrosion at the rear seat module connector located in the rear passenger footwells.

ACTION:

Should a customer express this concern, follow the Service Instruction below.

PARTS: **NOTE:**

heatshrink may be found in the Electrical Service Kit. If required, an allowance equivalent \$4.86 has been provided for locally sourced heatshrink and may be claimed using Sundry Code **ZZZ001**.

DESCRIPTION	QUANTITY:
Heatshrink	1

TOOLS:

Refer to Workshop Manual for any required special tools.

WARRANTY:

NOTE:

heatshrink may be found in the Electrical Service Kit. If required, an allowance equivalent \$4.86 has been provided for locally sourced heatshrink and may be claimed using Sundry Code **ZZZ001**.

NOTES:

- Repair procedures are under constant review, and therefore times are subject to change; those quoted here must be taken as guidance only. Always refer to TOPIx to obtain the latest repair time.
- The JLR Claims Submission System requires the use of causal part numbers. Labor only claims must show the causal part number with a quantity of zero

DESCRIPTION	SRO	TIME (HOURS)	CONDITION CODE	CAUSAL PART
Rear Seat Module - Wiring Repair	86.71.89.59	0.2	42	LR063860

NOTE:

Normal Warranty procedures apply.

COMPONENT LOCATION

1

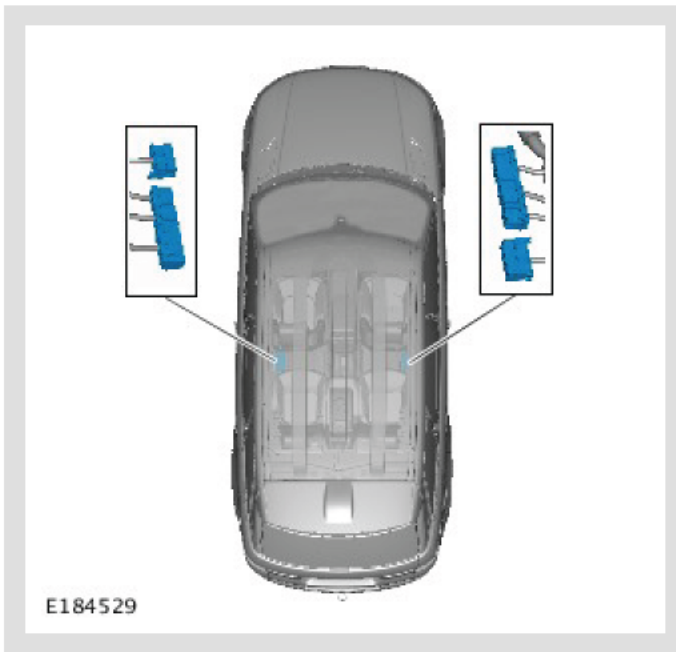

Component location.

SERVICE INSTRUCTION:

1

 **NOTE:**

Left-hand-side shown; right-hand-side similar.

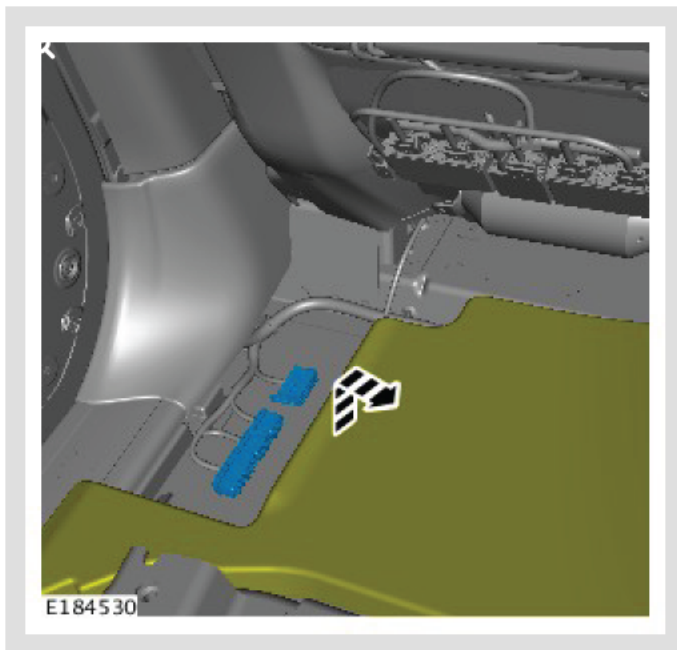

Remove rear passenger footwell left-hand and right-hand carpets enough to observe the rear seat module connections.

2

 **NOTE:**

Left-hand-side shown; right-hand-side similar.

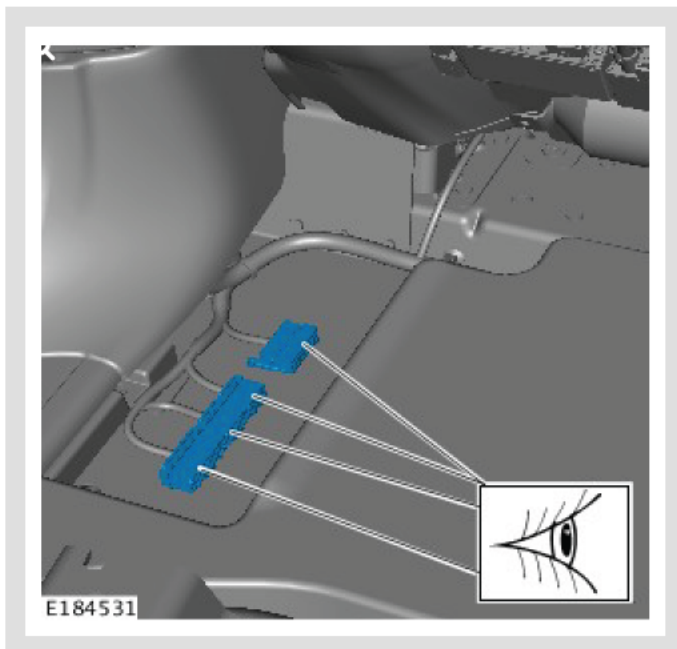

Check the following terminals for signs of corrosion:

- Range Rover Sport - rear left-hand footwell - C3PS186 A/B/C/D
- Range Rover Sport - rear right-hand footwell - C3PS185 A/B/C/D

- Range Rover - rear left-hand footwell - C3PS146 A/B/C/D
- Range Rover - rear right-hand footwell - C3PS145 A/B/C/D.
 - If no corrosion is evident in any connector, continue with normal diagnosis. Use SDD with reference to TOPIx.

NOTE:

the rear passenger footwell carpets must be dry before installation.

- Once rectified, reverse step 1 to install the rear passenger footwell carpets.
- If corrosion is evident in any connector, continue to the next ste.

3

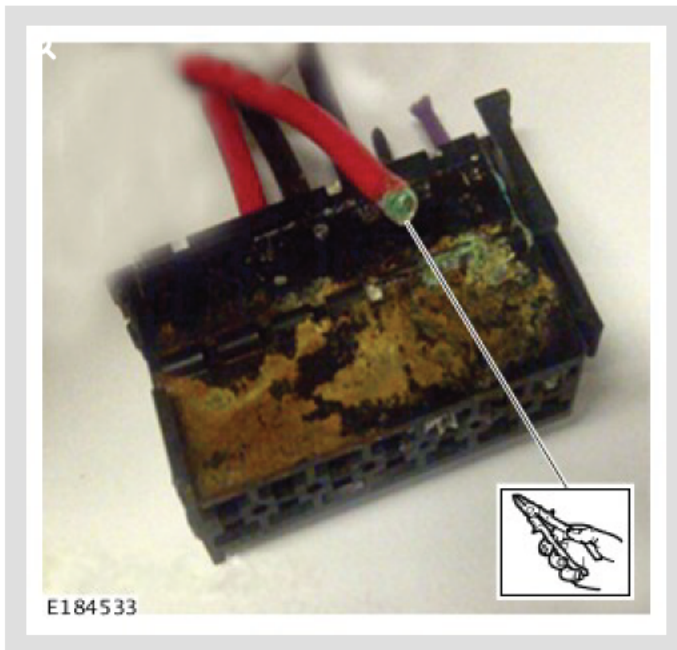

Remove the connector block and cut back the corroded wires to a suitable length until corrosion is no longer visible.

- Individually heat shrink the exposed wires.

4

NOTE:

Left-hand-side shown; right-hand-side similar.



Refit the wires to the position they were found.

- 5 If the carpets are found to be wet in the area of the repair, confirm the source of water ingress (climate control / roof opening panel drain tubes detached / blocked, external water ingress, or other than natural ingress via water or snow brought into the vehicle through footwell, etc.).

6  **NOTE:**

the rear passenger footwell carpets must be dry before installation.

Install the rear passenger footwell carpets.

- If necessary, dry the carpets before installation.

7 Verify the repair.

- If the concern is rectified, release the vehicle.
- If the concern is not rectified, continue with normal diagnosis. Use SDD with reference to TOPIx.

11 DEC 2015

© Jaguar Land Rover North America, LLC

NOTE: The information in Technical Bulletins is intended for use by trained, professional Technicians with the knowledge, tools, and equipment required to do the job properly and safely. It informs these Technicians of conditions that may occur on some vehicles, or provides information that could assist in proper vehicle service. The procedures should not be performed by 'do-it-yourselfers'. If you are not a Retailer, do not assume that a condition described affects your vehicle. Contact an authorized Land Rover service facility to determine whether this bulletin applies to a specific vehicle.

SECTION: 419-00

Both Keys Locked In Vehicle

AFFECTED VEHICLE RANGE:

Discovery Sport (LC)

Model Year: 2016 Onwards
VIN: 544577 Onwards
Assembly Plant: Halewood

Range Rover Evoque (LV)

Model Year: 2016 Onwards
VIN: 077912 Onwards
Assembly Plant: Halewood

Range Rover Sport (LW)

Model Year: 2015 Onwards
VIN: 504511 Onwards
Assembly Plant: Solihull

Range Rover (LG)

Model Year: 2015 Onwards
VIN: 197042 Onwards
Assembly Plant: Solihull

MARKETS:

NAS

CONDITION SUMMARY:

Situation: The vehicle may lock with both keys in the vehicle when operating the exterior handle.

Cause: This may be caused by a software issue with the Remote Function Actuator (RFA).

Action: Should a customer express this concern, refer to the Service Instruction outlined below.

PARTS:

No Parts Required

TOOLS:

△ NOTE: this Active Bulletin will display a functional programming shortcut if accessed within a diagnostic session using the Jaguar Land Rover-approved diagnostic tool with latest DVD and Calibration File.

 <p>IMAGE NOT AVAILABLE</p>	Jaguar Land Rover-approved diagnostic tool with latest DVD and Calibration File
--	---

	Jaguar Land Rover-approved Midtronics battery power supply
---	--

WARRANTY:

△ NOTE: the Remote Function Actuator (RFA) may also be referred to as the Keyless Vehicle Module (KVM).

△ NOTE: Repair procedures are under constant review, and therefore times are subject to change; those quoted here must be taken as guidance only. Always refer to TOPIx to obtain the latest repair time.

△ NOTE: The JLR Claims Submission System requires the use of causal part numbers. Labor only claims must show the causal part number with a quantity of zero.

DESCRIPTION	SRO	TIME (HOURS)	CONDITION CODE	CAUSAL PART
Configure Remote Function Actuator	86.90.84	0.2	42	LR071651

△ NOTE: Normal Warranty procedures apply.

SERVICE INSTRUCTION:

⚠ CAUTION: a Jaguar Land Rover-approved Midtronics battery power supply must be connected to the vehicle battery during diagnosis / module programming.

⚠ CAUTION: ensure all ignition ON/OFF requests are carried out; failure to perform these steps may cause damage to control modules in the vehicle.

△ NOTE: the Jaguar Land Rover-approved diagnostic tool must be loaded with DVD144.00 v.222 or later.

1. Connect the Jaguar Land Rover-approved Midtronics battery power supply to the vehicle battery.

△ NOTE: the Remote Function Actuator (RFA) may also be referred to as the Keyless Vehicle Module (KVM).

Click here to run the Configure existing module - Keyless vehicle module option (144.00 / 51250)

2. Turn ignition ON (engine not running).

3. Connect the Jaguar Land Rover-approved diagnostic tool to the vehicle and begin a new session.

4. Follow the on-screen prompts, allowing the diagnostic tool to read the VIN and identify the vehicle and initiating the data collect sequence.

5. Select **Diagnosis** from the Session Type screen.

6. Select the **Selected Symptoms** tab and then select:

- **Body > Security and Locking > Handles, locks and latches**

7. Select **continue**.

8. Select the **Recommendations** tab and then select **Run** to perform the **Configure existing module - Keyless vehicle module** option.

9. Follow all on-screen instructions to complete this task, ensuring all diagnostic trouble codes (DTC) are cleared.
10. Exit the current session.
11. Disconnect the diagnostic tool and battery power supply from the vehicle.



© Jaguar Land Rover North America, LLC

NOTE: The information in Technical Bulletins is intended for use by trained, professional Technicians with the knowledge, tools, and equipment required to do the job properly and safely. It informs these Technicians of conditions that may occur on some vehicles, or provides information that could assist in proper vehicle service. The procedures should not be performed by 'do-it-yourselfers'. If you are not a Retailer, do not assume that a condition described affects your vehicle. Contact an authorized Land Rover service facility to determine whether this bulletin applies to a specific vehicle.

This reissue replaces all previous versions. Please destroy all previous versions.

SECTION: 419-00

Both Keys Locked In Vehicle

AFFECTED VEHICLE RANGE:

Discovery Sport (LC)

Model Year: 2016
VIN: 544577-590668
Assembly Plant: Halewood

LR4 (LA)

Model Year: 2015-2016
VIN: 731301-806072
Assembly Plant: Solihull

Range Rover Evoque (LV)

Model Year: 2016
VIN: 077912-120519
Assembly Plant: Halewood

Range Rover Sport (LW)

Model Year: 2015-2016
VIN: 504511-570564
Assembly Plant: Solihull

Range Rover Sport (LW)

Model Year: 2015-2016
VIN: 601763-643877
Assembly Plant: Solihull

Range Rover (LG)

Model Year: 2015-2016
VIN: 197042-273032
Assembly Plant: Solihull

MARKETS:

NAS

CONDITION SUMMARY:

Situation: The vehicle may lock with both keys in the vehicle when operating the exterior handle.

Cause: This may be caused by a software issue with the Remote Function Actuator (RFA).



Action: Should a customer express this concern, refer to the Service Instruction outlined below.

PARTS:

No Parts Required

TOOLS:

△ NOTE: this Active Bulletin will display a functional programming shortcut if accessed within a diagnostic session using the Jaguar Land Rover-approved diagnostic tool with latest DVD and Calibration File.

	Jaguar Land Rover-approved diagnostic tool with latest DVD and Calibration File
	Jaguar Land Rover-approved Midtronics battery power supply

WARRANTY:

- △ NOTE: the Remote Function Actuator (RFA) may also be referred to as the Keyless Vehicle Module (KVM).
- △ NOTE: use DDW to check for Recall, Service Action, or Update Prior to Sale notice eligibility requiring a Remote Function Actuator (RFA) software update. If eligible, perform and claim the update as per that program.
- △ NOTE: Repair procedures are under constant review, and therefore times are subject to change; those quoted here must be taken as guidance only. Always refer to TOPIx to obtain the latest repair time.
- △ NOTE: The JLR Claims Submission System requires the use of causal part numbers. Labor only claims must show the causal part number with a quantity of zero.

DESCRIPTION	SRO	TIME (HOURS)	CONDITION CODE	CAUSAL PART
Configure Remote Function Actuator	86.90.84	0.2	42	LR071651

- △ NOTE: Normal Warranty procedures apply.

SERVICE INSTRUCTION:

- ⚠ CAUTION: a Jaguar Land Rover-approved Midtronics battery power supply must be connected to the vehicle battery during diagnosis / module programming.
- ⚠ CAUTION: ensure all ignition ON/OFF requests are carried out; failure to perform these steps may cause damage to control modules in the vehicle.
- △ NOTE: the Jaguar Land Rover-approved diagnostic tool must be loaded with DVD144.00 v.222 or later.
- △ NOTE: use DDW to check for Recall, Service Action, or Update Prior to Sale notice eligibility requiring a Remote Function Actuator (RFA) software update. If eligible, perform and claim the update as per that program.

1. Connect the Jaguar Land Rover-approved Midtronics battery power supply to the vehicle battery.

- △ NOTE: the Remote Function Actuator (RFA) may also be referred to as the Keyless Vehicle Module (KVM).

Click here to run the Configure existing module - Keyless vehicle module option (144.00 / 51250)

2. Turn ignition ON (engine not running).

3. Connect the Jaguar Land Rover-approved diagnostic tool to the vehicle and begin a new session.
4. Follow the on-screen prompts, allowing the diagnostic tool to read the VIN and identify the vehicle and initiating the data collect sequence.
5. Select **Diagnosis** from the Session Type screen.
6. Select the **Selected Symptoms** tab and then select:
 - **Body > Security and Locking > Handles, locks and latches**
7. Select **continue**.
8. Select the **Recommendations** tab and then select **Run** to perform the **Configure existing module - Keyless vehicle module** option.
9. Follow all on-screen instructions to complete this task, ensuring all diagnostic trouble codes (DTC) are cleared.
10. Exit the current session.
11. Disconnect the diagnostic tool and battery power supply from the vehicle.

LTB00965NAS1

TECHNICAL BULLETIN

27 JUN 2016



A JAGUAR COMPANY

© Jaguar Land Rover North America, LLC

NOTE: The information in Technical Bulletins is intended for use by trained, professional Technicians with the knowledge, tools, and equipment required to do the job properly and safely. It informs these Technicians of conditions that may occur on some vehicles, or provides information that could assist in proper vehicle service. The procedures should not be performed by 'do-it-yourselfers'. If you are not a Retailer, do not assume that a condition described affects your vehicle. Contact an authorized Land Rover service facility to determine whether this bulletin applies to a specific vehicle.

INFORMATION

SECTION:

501-03

SUBJECT/CONCERN:

Rear Side Door Difficult To Open

AFFECTED VEHICLE RANGE:

MODEL:	MODEL YEAR:	VIN:	ASSEMBLY PLANT:
Range Rover (LG)	2013 Onwards	001171 Onwards	Solihull

MARKETS:

NAS

CONDITION SUMMARY:**SITUATION:**

Either rear side door may be difficult to open.

CAUSE:

This may be caused by the rear door margin flip seal becoming kinked or trapped behind the rear quarter window.

ACTION:

Should a customer express this concern, follow the Service Instruction below.

PARTS:

PART NUMBER	DESCRIPTION	QUANTITY:
LR079423	RH upper door seal (SWB)	1
LR079424	LH upper door seal (SWB)	1
LR079442	RH upper door seal (LWB)	1
LR079443	LH upper door seal (LWB)	1

TOOLS:

Refer to Workshop Manual for any required special tools.

WARRANTY: **NOTE:**

If required, an allowance (\$152.00) may be claimed to cover the cost of a vehicle window replacement technician to remove and install the rear quarter window. Claim using 'ZZZ001'.

△ NOTES:

- Repair procedures are under constant review, and therefore times are subject to change; those quoted here must be taken as guidance only. Always refer to TOPIx to obtain the latest repair time.
- The JLR Claims Submission System requires the use of causal part numbers. Labor only claims must show the causal part number with a quantity of zero

DESCRIPTION	SRO	TIME (HOURS)	CONDITION CODE	CAUSAL PART
Rear Quarter Window Gap - Check / Apply Slip Coat	76.81.60	0.7	12	LR034327
Rear Quarter Window - Remove, Adjust & Refit	76.81.61	2.0	12	LR034327
Flip seal - Rear door - Renew	76.31.58	0.1	12	LR034327

△ NOTE:

Normal Warranty procedures apply.

SERVICE INSTRUCTION:

△ NOTES:

- **This repair process requires the assistance of a vehicle window replacement technician.**
- **Repeat this Service Instruction for both sides of the vehicle.**

1

△ NOTE:

Left side shown; right side similar.

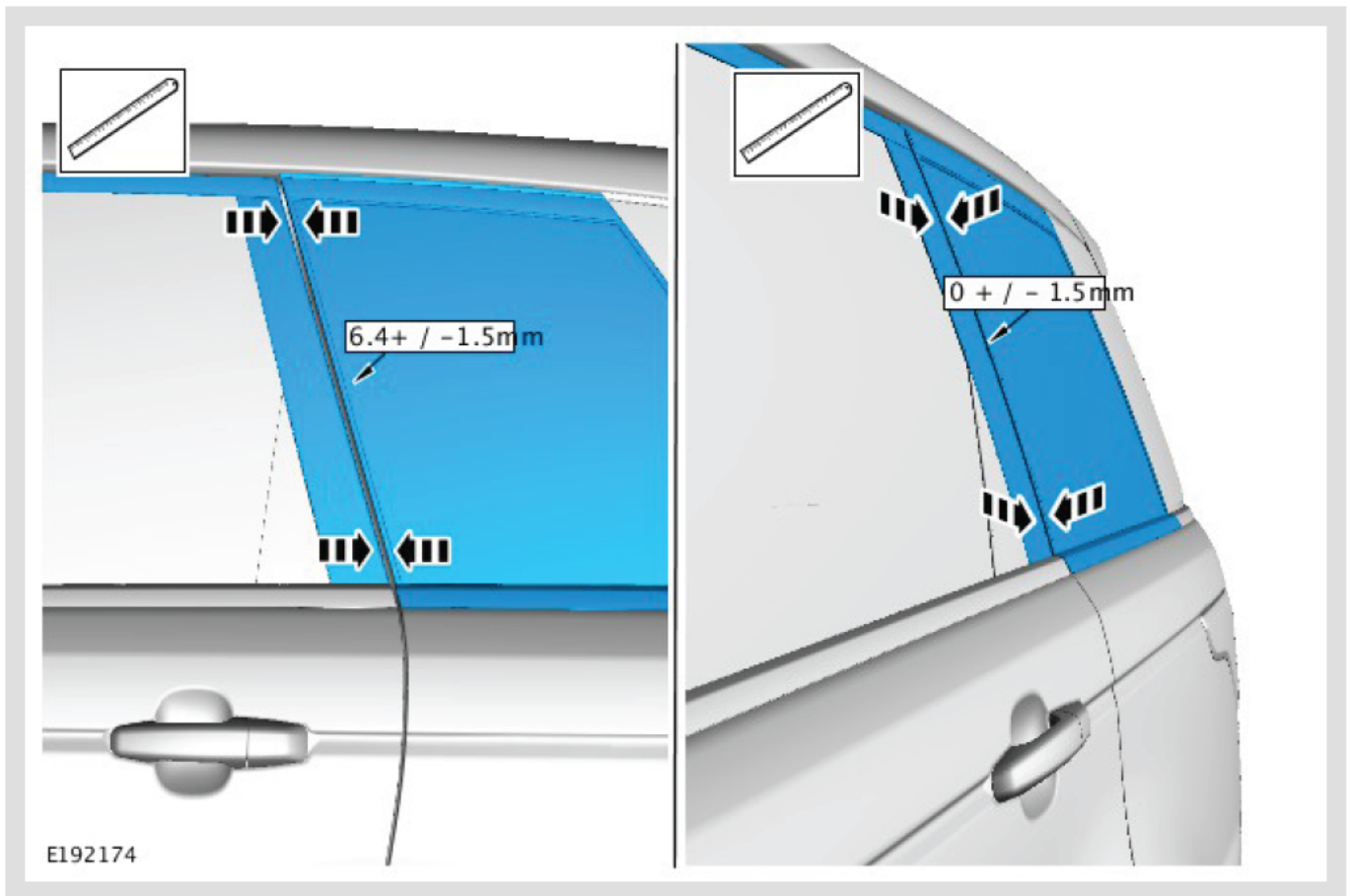

Measure the alignment between the rear door and rear quarter window (record measurement).

- 1 If the alignment does not meet the specifications shown, go to Step 2.
- 2 If the alignment does meet the specifications, apply slip coating (as supplied in the Squeak & Rattle kit) to the margin seal flock coating and front edge of the rear quarter window.
 - Apply 6-8 times, allowing approximately 5 minutes between applications for each coat to dry.

2 Remove the C-pillar Upper Trim Panel (see TOPIx Workshop Manual section 501-05: Interior Trim and Ornamentation).

3 Remove the D-pillar Trim Panel (see TOPIx Workshop Manual section 501-05: Interior Trim and Ornamentation).

- 4 Remove the Rear Quarter Panel Moulding (see TOPIx Workshop Manual section 501-08: Exterior Trim and Ornamentation).

- 5 With the assistance of a vehicle window replacement technician, remove the rear quarter window.

- 6  NOTE:

Left side shown; right side similar.

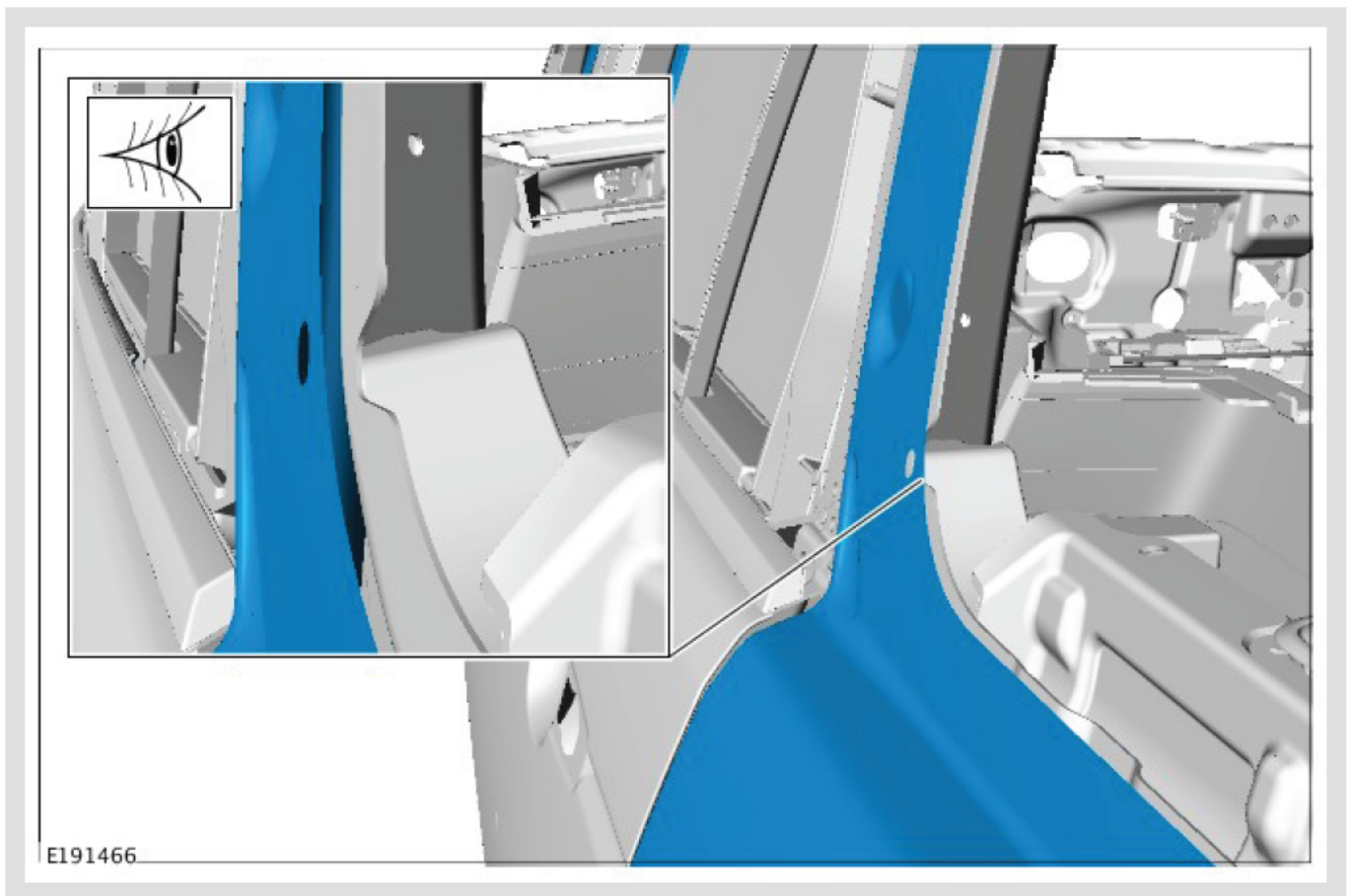

Visually check the body panel.

- 1 If there is a gap between the body panel and reinforcement panel, go to Step 7.
- 2 If there is no gap between the body panel and reinforcement panel, go to Step 8.

- 7  NOTE:

Left side shown; right side similar.

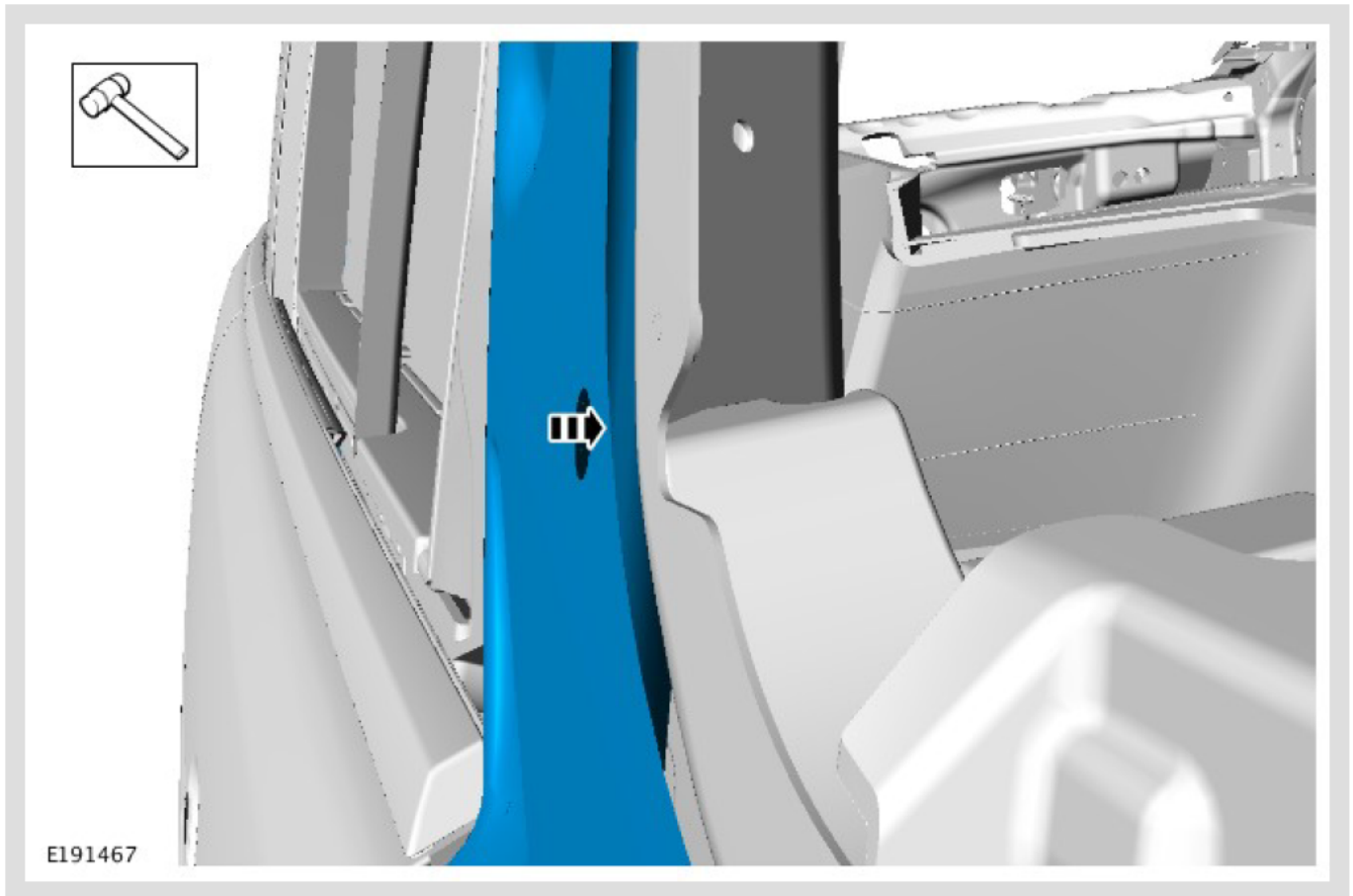

Using a suitable tool, dress the body panel until the gap between the body panel and reinforcement panel has been closed.

8 Place rear quarter window in its location without adhesive and check that the alignment specifications can be achieved.

- 1** If the alignment specifications cannot be achieved, go to Step 7.
- 2** If the alignment specifications can be achieved, go to Step 9.

9

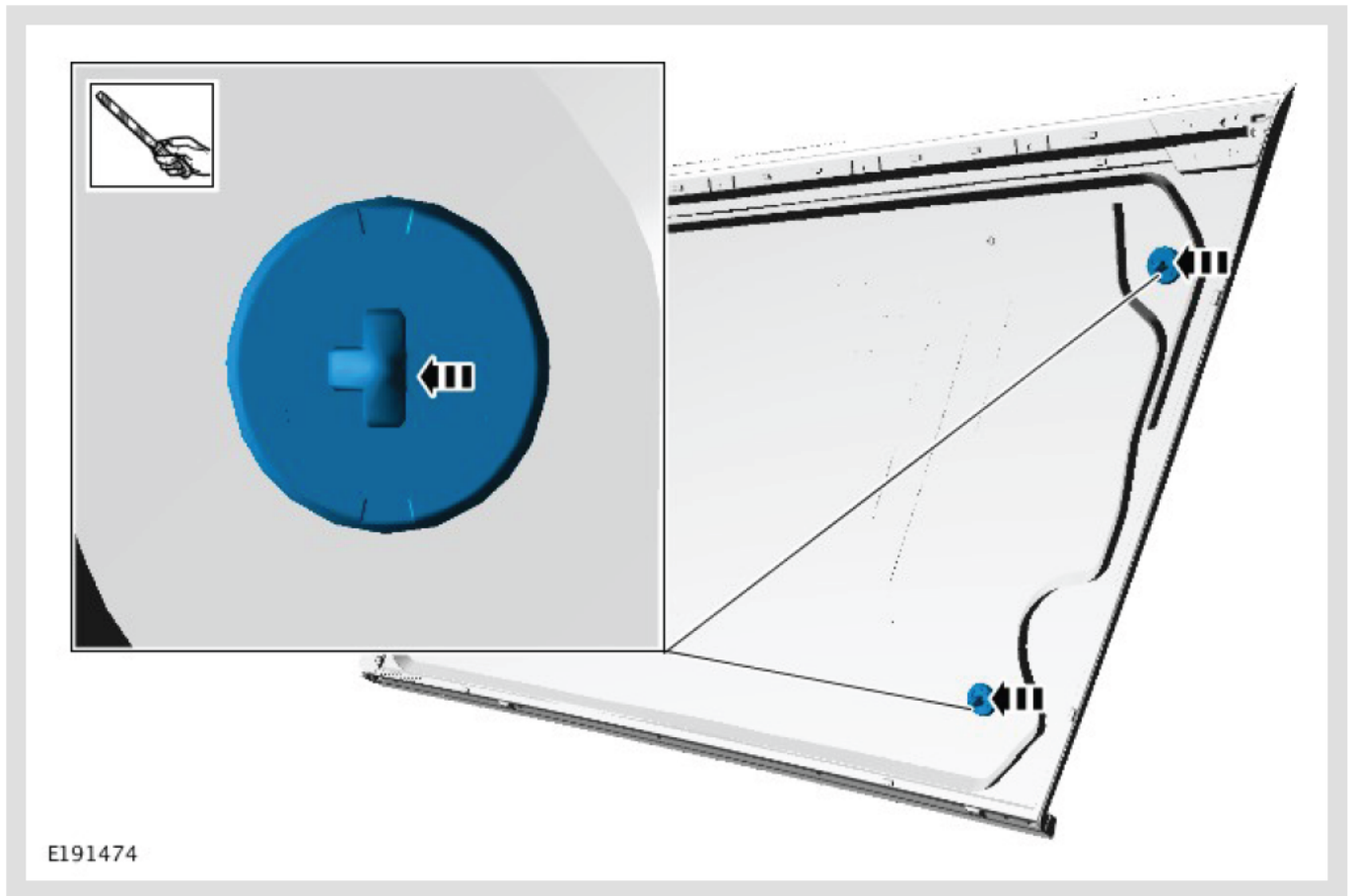

Using a suitable tool, trim the window location pins on the edge closest to the front of the vehicle until the desired gap is achieved.

10

△ NOTES:

- **A vehicle technician must be present to make sure that the window is located correctly so that the alignment specifications are met.**
- **Secure the window with tape during the curing time to make sure the desired position is maintained.**

With the assistance of a vehicle window replacement technician, install the rear quarter window.

11

Install the C-pillar Upper Trim Panel (see TOPIx Workshop Manual section 501-05: Interior Trim and Ornamentation).

12 Install the D-pillar Trim Panel (see TOPIx Workshop section 501-05: Interior Trim and Ornamentation).

13 Install the Rear Quarter Panel Moulding (see TOPIx Workshop Manual section 501-08: Exterior Trim and Ornamentation).

14 Apply slip coating (as supplied in the Squeak & Rattle kit) to the margin seal flock coating and front edge of the rear quarter window.

- 1 Apply 6-8 times, allowing approximately 5 minutes between applications for each coat to dry.
-

15 Visually check the condition of the rear door upper seal.

- 1 If the rear door upper seal is not damaged, return the vehicle to the customer.
 - 2 If the rear door upper seal is damaged, go to Step 16.
-

16

 **NOTE:**

Rear right door shown; rear left similar.

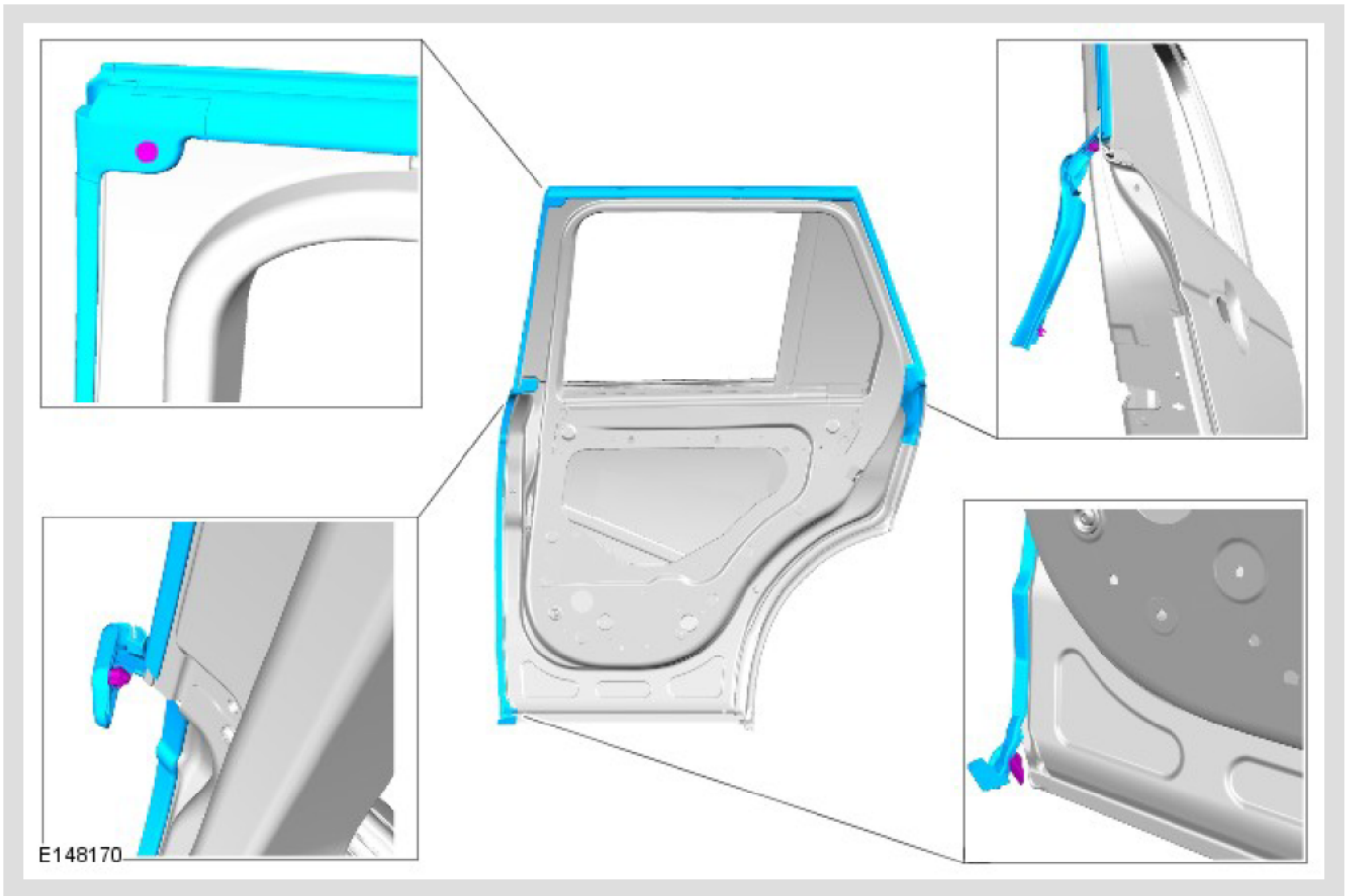

Replace the rear upper door seal.

LTB01086

TECHNICAL BULLETIN

26 JUL 2017



LAND ROVER

© Jaguar Land Rover Limited

All rights reserved.

INFORMATION

SECTION:

501-14

SUBJECT/CONCERN:

Keyless Entry Is Inoperative Or Intermittent

AFFECTED VEHICLE RANGE:

MODEL:	MODEL YEAR:	VIN:	ASSEMBLY PLANT:
Range Rover Evoque (LV)	2012 Onwards	600000 Onwards	Halewood

MODEL:	MODEL YEAR:	VIN:	ASSEMBLY PLANT:
Range Rover Evoque (JV)	2016 Onwards	000062 Onwards	Itatiaia (Brazil)
Range Rover Evoque (CV)	2015 Onwards	100001 Onwards	Changshu
Range Rover Evoque (LV)	2015 Onwards	920000 Onwards	
Discovery Sport (LC)	2015 Onwards	501001 Onwards	Halewood
Discovery Sport (JC)	2016 Onwards	200008 Onwards	Itatiaia (Brazil)
Discovery Sport (CC)	2015 Onwards	300003 Onwards	Changshu
Discovery Sport (LC)	2017 Onwards	961561 Onwards	
Range Rover (LG)	2013 Onwards	000140 Onwards	Solihull
Range Rover Sport (LW)	2014 Onwards	601621 Onwards	Solihull
Discovery (LR)	2017 Onwards	025687 Onwards	Solihull

MARKETS:

ASIA PACIFIC; CHINA; EUROPE; JAPAN; MENA; OVERSEAS

CONDITION SUMMARY:

NOTE:

PUNE assembled vehicles are affected by this bulletin.

SITUATION:

A customer may express concern that the keyless entry lock function may not operate or only operates intermittently. **Suggested customer concern code AK7.**

CAUSE:

Water ingress into the exterior door handles prevents correct operation of the keyless entry lock function.

ACTION:

Should a customer express concern, follow the service instruction below.

PARTS:



NOTE:

Only order the quantity required for each vehicle repair.

PART NUMBER	DESCRIPTION	QUANTITY:
LR061200	Door handle exterior - Primed (Dimple on handle)	1
LR040667	Door handle exterior - Primed (Stripes on handle)	1
LR055917	Door handle exterior - Chrome - Aintree Green	1
LR075119	Door handle exterior - Chrome - Aruba Gold 1	1
LR055923	Door handle exterior - Chrome - Barolo Black	1
LR055907	Door handle exterior - Chrome - Barossa	1
LR076447	Door handle exterior - Chrome - Carpathian Grey	1
LR055904	Door handle exterior - Chrome - Causeway Grey	1
LR056188	Door handle exterior - Chrome - Corris Grey	1
LR055914	Door handle exterior - Chrome - Firenze Red	1
LR055921	Door handle exterior - Chrome - Fuji White	1
LR055911	Door handle exterior - Chrome - Havana	1
LR055920	Door handle exterior - Chrome - Indus Silver	1
LR055913	Door handle exterior - Chrome - Kaikoura Stone	1
LR046326	Door handle exterior - Chrome - Loire Blue	1
LR055903	Door handle exterior - Chrome - Luxor	1

PART NUMBER	DESCRIPTION	QUANTITY:
LR055905	Door handle exterior - Chrome - Mariana Black	1
LR075120	Door handle exterior - Chrome - Montaicino Red	1
LR055906	Door handle exterior - Chrome - Nara Bronze	1
LR055916	Door handle exterior - Chrome - Santorini Black	1
LR067443	Door handle exterior - Chrome - Scotia Grey	1
LR072371	Door handle exterior - Chrome - Yulong White	1
LR013135	8.5x0.8-2.2 clip	12
LR044885	8.2x1.2+2.5 clip	1
LR006101	8.2x0.7-1.5 clip	10
LR090382	Clip	4

WARRANTY:

NOTES:

- Repair procedures are under constant review, and therefore times are subject to change; those quoted here must be taken as guidance only. Always refer to TOPIx to obtain the latest repair time.
- The JLR Claims Submission System requires the use of causal part numbers. Labor only claims must show the causal part number with a quantity of zero

DESCRIPTION	SRO	TIME (HOURS)	CONDITION CODE	CAUSAL PART
L462 - Handle - Exterior - Front door - Renew	76.58.08	0.9	49	LR061200

DESCRIPTION	SRO	TIME (HOURS)	CONDITION CODE	CAUSAL PART
L462 - Handle - Exterior - Rear door - Renew	76.58.02	0.6	49	LR061200
L550 - Handle - Exterior - Front door - Renew	76.58.07	0.7	49	LR061200
L550 - Handle - Exterior - Rear door - Renew	76.58.02	0.5	49	LR061200
L538 - Handle - Exterior - Front door - Renew	76.58.07	0.5	49	LR061200
L538 - Handle - Exterior - Rear door - Renew	76.58.02	0.4	49	LR061200
L405 - Handle - Exterior - Front door - Renew	76.58.07	0.6	49	LR061200
L405 - Long wheelbase - Handle - Exterior - Rear door - Renew	76.58.02	0.9	49	LR061200
L405 - Standard wheelbase - Handle - Exterior - Rear door - Renew	76.58.02	0.5	49	LR061200
L494- Handle - Exterior - Front door - Renew	76.58.07	0.7	49	LR061200
L494- Handle - Exterior - Rear door - Renew	76.58.02	0.5	49	LR061200
Door handles - Each/set - Local color	79.E.AJ3	0.6	49	LR061200

 **NOTE:**

Normal Warranty procedures apply.

SERVICE INSTRUCTION:

- 1 If the customer concern relates to the exterior front door handle(s) keyless entry locking not operating as it should, continue to step 2. If the customer concern relates to the exterior rear door handle(s) keyless entry

locking not operating as it should, continue to step 3. If required, perform steps 2 and 3.

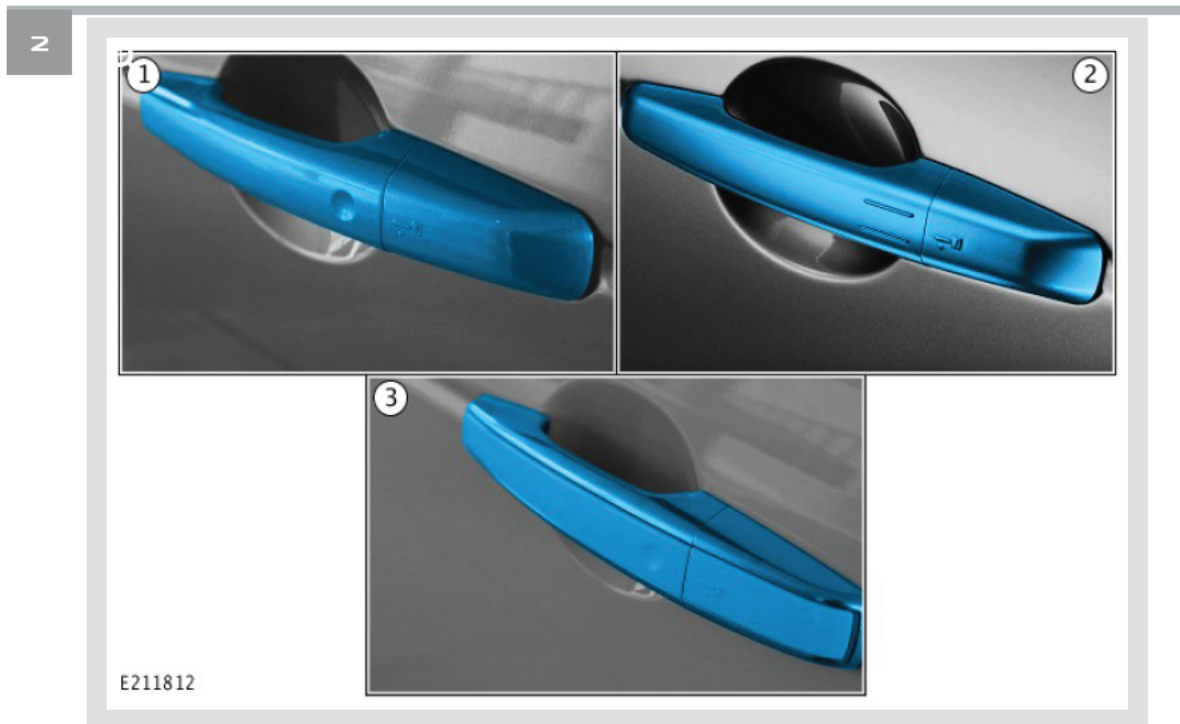

Inspect the type of handle that is to be replaced, to make sure the correct replacement handle is ordered for the vehicle. Refer to the illustration for the different handle types.

- (1) shows the dimple type handle LR061200.
- (2) shows the stripe type handle LR040667.
- (3) shows the chrome type handle supplied by color.

3

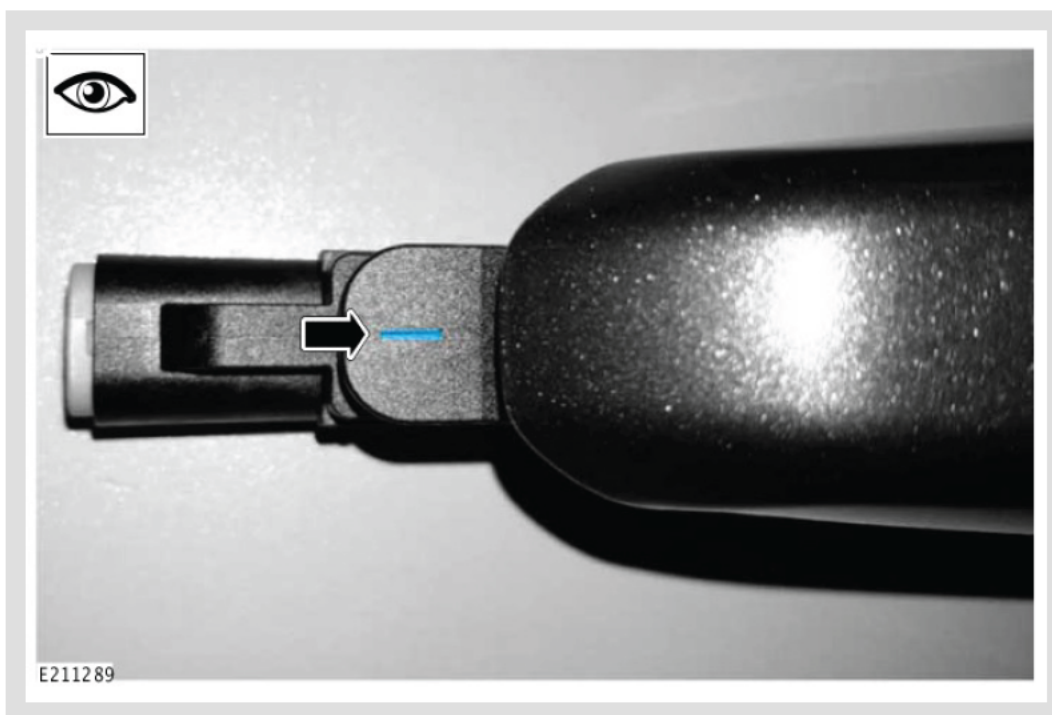

Inspect the replacement handle to make sure it is the correct replacement part. Inspect the handle for the correct identification mark as shown in the illustration.

4

 **NOTE:**

If required the exterior door handle(s) must be painted before installation.

Replace the defective exterior door handle(s), (see TOPIx Workshop Manual section: 501-14 - Exterior Front Door Handle).

5

 **NOTE:**

If required the exterior door handle(s) must be painted before installation.

Replace the defective exterior door handle(s), (see TOPIx Workshop Manual section: 501-14 - Exterior Rear Door Handle).

LTB01086NAS3



TECHNICAL BULLETIN

03 MAY 2018

© Jaguar Land Rover North America, LLC

NOTE: The information in Technical Bulletins is intended for use by trained, professional Technicians with the knowledge, tools, and equipment required to do the job properly and safely. It informs these Technicians of conditions that may occur on some vehicles, or provides information that could assist in proper vehicle service. The procedures should not be performed by 'do-it-yourselfers'. If you are not a Retailer, do not assume that a condition described affects your vehicle. Contact an authorized Land Rover service facility to determine whether this bulletin applies to a specific vehicle.

SECTION:

501-14: Handles, Locks, Latches and Entry Systems

SUBJECT/CONCERN:

Keyless Entry System Lock Function May Not Operate and/or Operates Intermittently

AFFECTED VEHICLE RANGE:

MODEL:	MODEL YEAR:	VIN:	ASSEMBLY PLANT:
Discovery Sport (LC)	2015-2018	501001-734327	Halewood
Discovery (LR)	2017	000127-043056	Solihull
Range Rover Evoque (LV)	2012-2015	600018-999999	Halewood
Range Rover Evoque (LV)	2015-2018	000051-280762	Halewood
Range Rover Sport (LW)	2014-2018	601621-699998	Solihull
Range Rover Sport (LW)	2014-2015	300003-399999	Solihull
Range Rover Sport (LW)	2014-2016	500023-599999	Solihull

MODEL:	MODEL YEAR:	VIN:	ASSEMBLY PLANT:
Range Rover Sport (LW)	2016-2017	100000-176036	Solihull
Range Rover (LG)	2013-2018	000140-375939	Solihull

MARKETS:

NORTH AMERICA

CONDITION SUMMARY:

SITUATION:

The keyless entry system lock function may not operate or operates intermittently.

CAUSE:

This may be caused by water ingress into the door exterior handles preventing correct operation of the keyless entry lock function.

NOTE:

Certain Steps must be performed by a Jaguar Land Rover-approved bodyshop.

ACTION:

Should a customer express concern, follow the Workshop Procedure below.

PARTS:

NOTES:

- It is not necessary to replace all door exterior handles; only order the quantity required per the customer concern.

Where door handle covers or inserts are supplied in primer, a maximum allowance of \$32.50 USD or local equivalent has been allocated to cover the cost of paint and materials.

PART NUMBER	DESCRIPTION	QUANTITY
LR061200	Door handle exterior with primed cover (Dimple on handle)	4
LR040667	Door handle exterior with primed cover (Stripes on handle)	4
LR106320	Door handle exterior with primed insert (Dimple - Noble Chrome)	4
LR053502	Door handle exterior with primed insert (Dimple - Bright Chrome)	4
LR068146	Door handle exterior with primed insert (Dimple - Santorini Gloss black)	4
LR096116	Door handle exterior with primed insert (Dimple - Atlas Chrome)	4
LR055917	Door handle exterior - Chrome - Aintree Green	4
LR075119	Door handle exterior - Chrome - Aruba Gold	4
LR055923	Door handle exterior - Chrome - Barolo Black	4
LR055907	Door handle exterior - Chrome - Barossa	4
LR076447	Door handle exterior - Chrome - Carpathian Grey	4
LR055904	Door handle exterior - Chrome - Causeway Grey	4
LR056188	Door handle exterior - Chrome - Corris Grey	4
LR055914	Door handle exterior - Chrome - Firenze Red	4
LR055921	Door handle exterior - Chrome - Fuji White	4
LR055911	Door handle exterior - Chrome - Havana	4
LR055920	Door handle exterior - Chrome - Indus Silver	4
LR055913	Door handle exterior - Chrome - Kaikoura Stone	4
LR046326	Door handle exterior - Chrome - Loire Blue	4
LR055903	Door handle exterior - Chrome - Luxor	4
LR055905	Door handle exterior - Chrome - Mariana Black	4
LR075120	Door handle exterior - Chrome - Montalcino Red	4
LR055906	Door handle exterior - Chrome - Nara Bronze	4

PART NUMBER	DESCRIPTION	QUANTITY
LR055916	Door handle exterior - Chrome - Santorini Black	4
LR067443	Door handle exterior - Chrome - Scotia Grey	4
LR072371	Door handle exterior - Chrome - Yulong White	4
LR013135	Trim panel clip 8.5 x 0.8 - 2.2	38
LR044885	Trim panel clip 8.2 x 1.2 + 2.5 clip	4
LR006101	Trim panel clip 8.2 x 0.7 - 1.5 clip	40
LR090382	Trim panel clip	4
ZZZ001	Paint and materials	\$32.50 USD or local equivalent

TOOLS:

Refer to Workshop Manual for any required special tools.

WARRANTY:

NOTES:

- It is not necessary to replace all door exterior handles; only order the quantity required per the customer concern.

Certain Steps must be performed by a Jaguar Land Rover-approved bodyshop.

Where door handle covers or inserts are supplied in primer, a maximum allowance of \$32.50 USD or local equivalent has been allocated to cover the cost of paint and materials.

NOTES:

- Repair procedures are under constant review, and therefore times are subject to change; those quoted here must be taken as guidance only. Use TOPIx to obtain the latest repair time.

- The JLR claims submission system requires the use of causal part numbers. Labor only claims must show the causal part number with a quantity of zero.

DESCRIPTION	SRO	TIME (HOURS)	CONDITION CODE	CAUSAL PART
Handle - Exterior - Front door - Single - Renew - Discovery Sport (L550)	76.58.07	0.7	49	LR061200
Handle - Exterior - Front door - Pair - Renew - Discovery Sport (L550)	76.58.46	1.4	49	LR061200
Handle - Exterior - Rear door - Single - Renew - Discovery Sport (L550)	76.58.02	0.5	49	LR061200
Handle - Exterior - Rear door - Pair - Renew - Discovery Sport (L550)	76.58.47	1.0	49	LR061200
Handle - Exterior - Front door - Single - Renew - Discovery (L462)	76.58.07	1.1	49	LR061200
Handle - Exterior - Front door - Pair - Renew - Discovery (L462)	76.58.46	2.2	49	LR061200
Handle - Exterior - Rear door - Single - Renew - Discovery (L462)	76.58.02	0.6	49	LR061200
Handle - Exterior - Rear door - Pair - Renew - Discovery (L462)	76.58.47	1.2	49	LR061200
Handle - Exterior - Front door - Single - Renew - Range Rover Evoque (L538)	76.58.07	0.5	49	LR061200
Handle - Exterior - Front door - Pair - Renew - Range Rover Evoque (L538)	76.58.46	1.0	49	LR061200
Handle - Exterior - Rear door - Single - Renew - Range Rover Evoque (L538)	76.58.02	0.4	49	LR061200
Handle - Exterior - Rear door - Pair - Renew - Range Rover Evoque (L538)	76.58.47	0.8	49	LR061200
Handle - Exterior - Front door - Single - Renew - Range Rover Sport (L494)	76.58.07	0.7	49	LR061200
Handle - Exterior - Front door - Pair - Renew - Range Rover Sport (L494)	76.58.46	1.4	49	LR061200
Handle - Exterior - Rear door - Single - Renew - Range Rover Sport (L494)	76.58.02	0.5	49	LR061200
Handle - Exterior - Rear door - Pair - Renew - Range Rover Sport (L494)	76.58.47	1.0	49	LR061200

DESCRIPTION	SRO	TIME (HOURS)	CONDITION CODE	CAUSAL PART
Handle - Exterior - Front door - Single - Renew - Range Rover (L405)	76.58.07	0.6	49	LR061200
Handle - Exterior - Front door - Pair - Renew - Range Rover (L405)	76.58.46	1.2	49	LR061200
Handle - Exterior - Rear door - Single - Renew - Range Rover (L405; Standard wheelbase)	76.58.02	0.5	49	LR061200
Handle - Exterior - Rear door - Pair - Renew - Range Rover (L405; Standard wheelbase)	76.58.47	1.0	49	LR061200
Handle - Exterior - Rear door - Single - Renew - Range Rover (L405; Long wheelbase)	76.58.02	0.9	49	LR061200
Handle - Exterior - Rear door - Pair - Renew - Range Rover (L405; Long wheelbase)	76.58.47	1.8	49	LR061200
Door handles - Each/set - Local color	79.E.AJ3	0.6	49	LR061200
Door exterior handle Kit - Single - Assemble	76.58.89.38	0.1	49	LR061200
Door exterior handle Kit - Pair - Assemble	76.58.89.36	0.1	49	LR061200
Door exterior handle Kit - Set of 4 - Assemble	76.58.89.37	0.3	49	LR061200

NOTE:

Normal Warranty procedures apply.

WORKSHOP PROCEDURE:

NOTE:

Certain Steps must be performed by a Jaguar Land Rover-approved bodyshop.

1

NOTE:

Front left door handle shown; others similar.

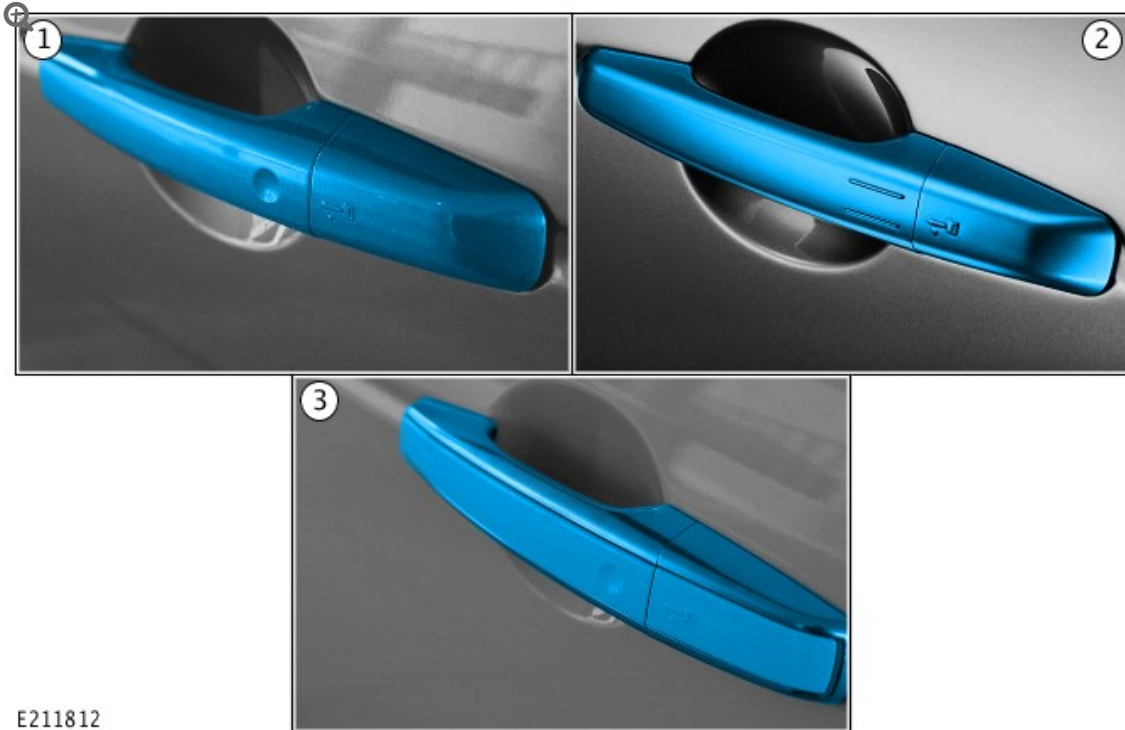

E211812

Identify the existing door exterior handle(s).

- (1) - 'dimple' type handle
- (2) - 'stripe' type handle
- (3) - 'chrome' type handle

2

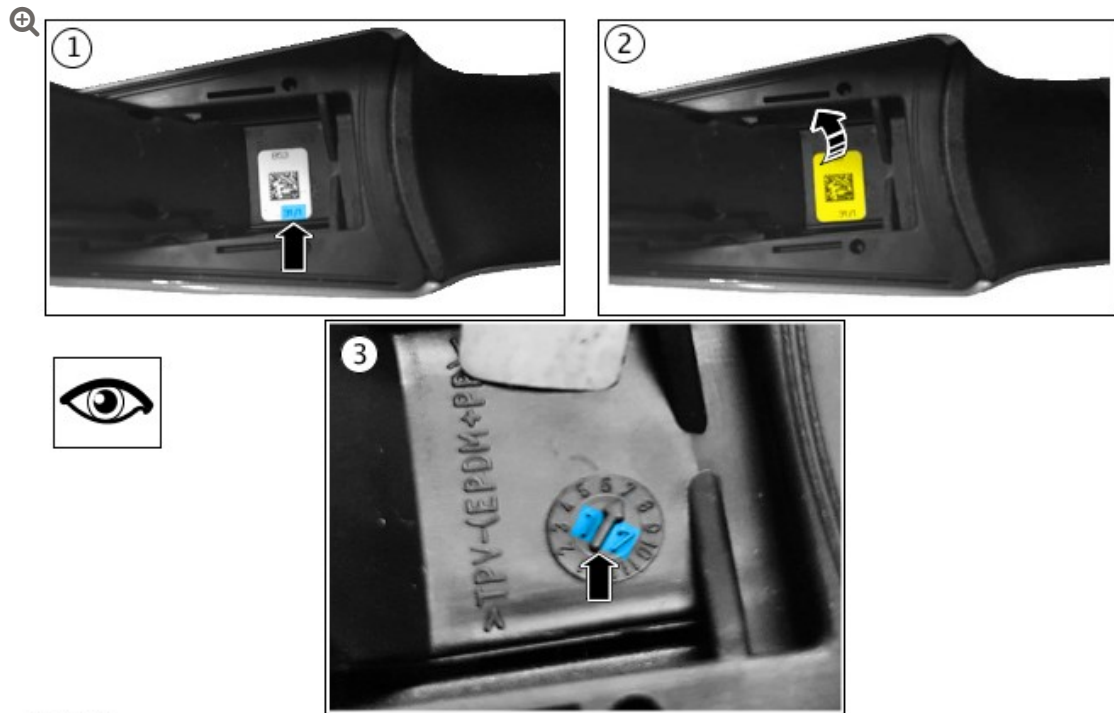

E222292

Record the production date of the NEW door exterior handle(s).

- 1 The label displays the production day and month. ('31/1' = 31 January).
- 2 Peel back the label to display the production year stamp ('17' = 2017).
 - If the production date is 03/08/2017 (03 August 2017) or later, **go to Step 4.**
 - If the production date is 02/08/2017 (02 August 2017) or earlier, **go to Step 3.**

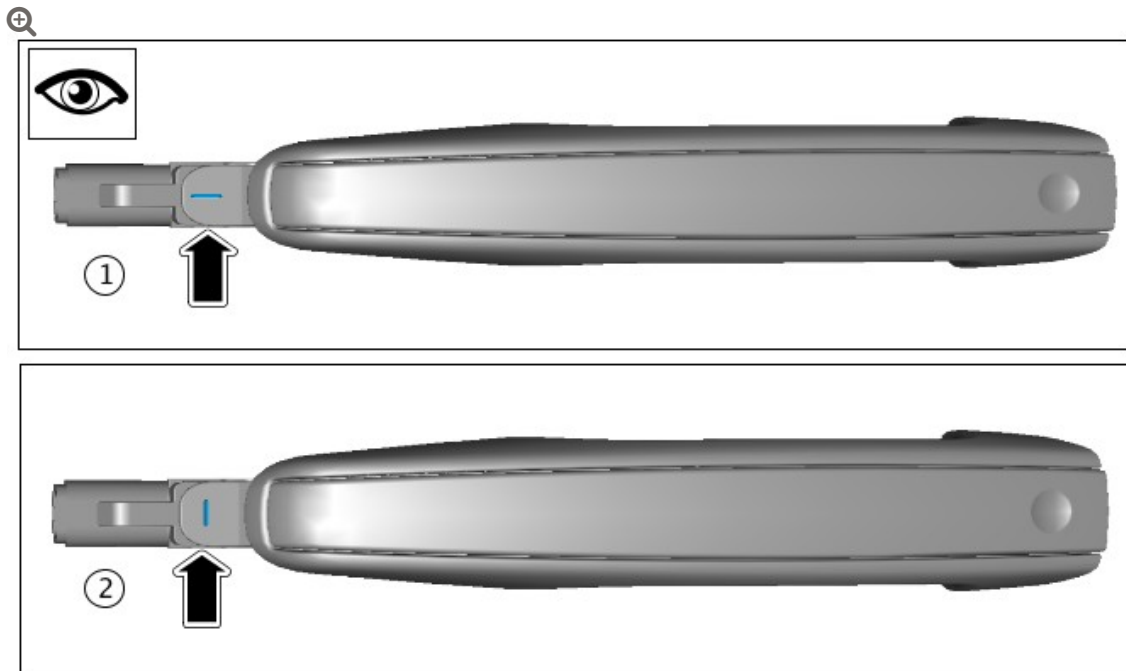

E222286

Inspect the marking(s) on the replacement door exterior handle(s).

- Horizontal marking **(1)** denotes that the handles are supplied pre-assembled. **Go to Step 4.**
- Vertical marking **(2)** denotes that the handles are supplied in kit form. **Go to Step 4.**
- If the new door exterior handle(s) have neither of the above markings and have a production date of 02/08/2017 or earlier, **DO NOT** use these parts. **Return the parts order new replacement door exterior handles and follow the steps above again.**

4

NOTE:

The number of door exterior handles to be replaced will be dependant on the number identified as a concern by the customer.

Identify if the door exterior handles require painting before they are installed.

- If the door exterior handle(s) are supplied in the correct color for the vehicle, **go to Step 20.**

- If the door exterior handle(s) are supplied in kit form partially in primer (covers or inserts must be painted in the correct color to match the vehicle) **go to Step 6.**
- If the door exterior handle(s) are supplied pre-assembled partially in primer (covers or inserts must be painted in the correct color to match the vehicle), **go to Step 5.**

5

CAUTIONS:

DO NOT dismantle pre-assembled door exterior handles before painting as this will cause damage to the weatherproof seals.

This Step must be performed by a Jaguar Land Rover-approved bodyshop.

Labor time is included in the SRO make sure care is taken when masking the door handle for painting. Accurate masking is essential to achieve a satisfactory finish on the exterior door handle.

NOTE:

This step is only applicable to pre-assembled door exterior handles that require painting.

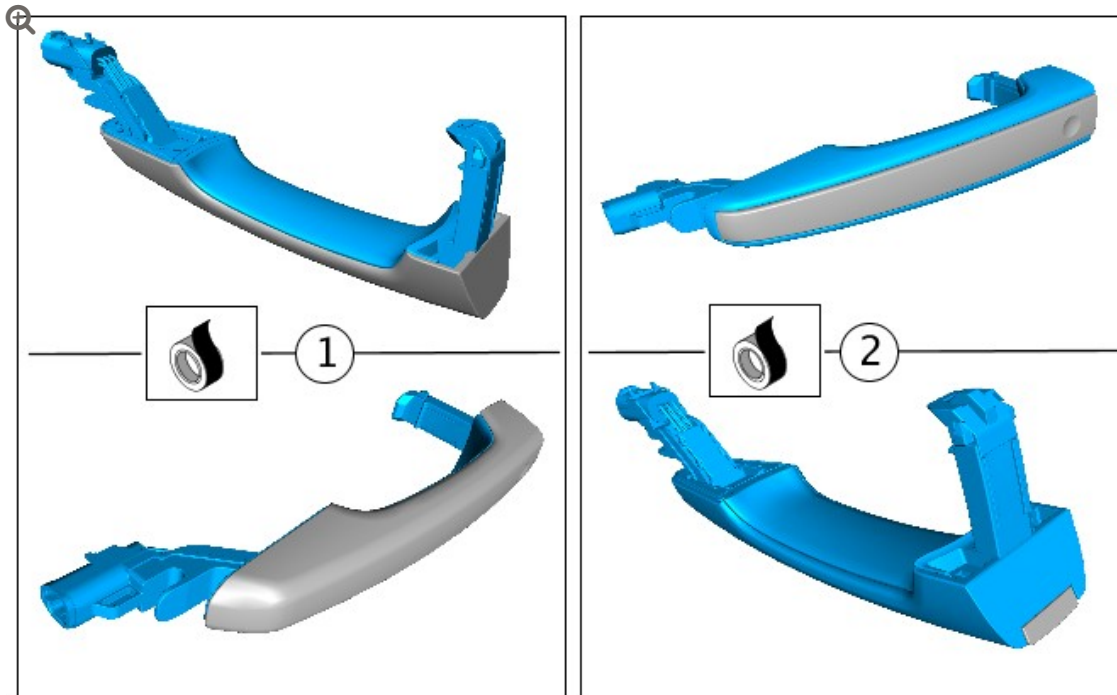

E222287

Masking directions:

- **Type (1) handles:** mask the areas highlighted in blue. Part numbers: LR040667, LR061200.
- **Type (2) handles:** mask the areas highlighted in blue. Part numbers: LR0106320, LR053502, LR068146, LR096116.

-
- 6 Paint the door exterior handle covers/inserts in the correct color to match the vehicle.
- For pre-assembled door exterior handles, allow the paint to dry.
 - Once the paint is dry, remove the tape and **go to Step 20**.
 - For door exterior handles in kit form, allow the paint to dry.
 - Once the paint is dry, **go to Step 7**.

7

NOTE:

Only applicable to door exterior handles with painted inserts.



E212042

Install the painted door exterior handle insert into the door exterior handle cover **(1)**.

- The painted door exterior handle insert is shown in the installed position **(2)**.
- Viewed from the rear, make sure all the clips are engaged **(3)** and that the door exterior handle insert is securely installed.



E211518

Prepare the door exterior handle strap inner and electronic module for assembly.

- Remove the yellow backing from the tape on the electronic unit.

9

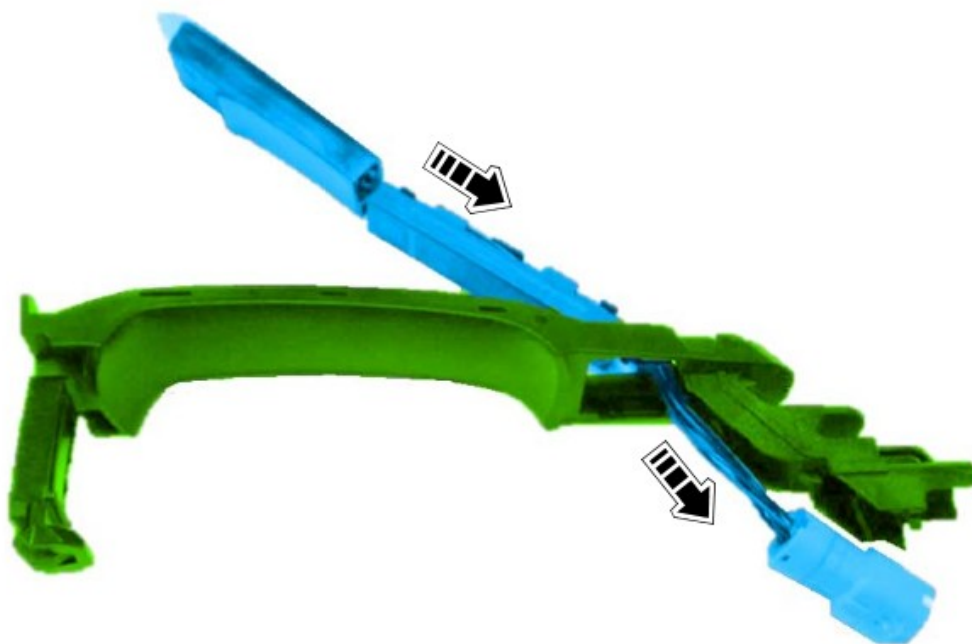

E211520

Insert the electrical connector through the door exterior handle strap inner.

10

NOTE:

Make sure the electrical connector is correctly orientated (✓).

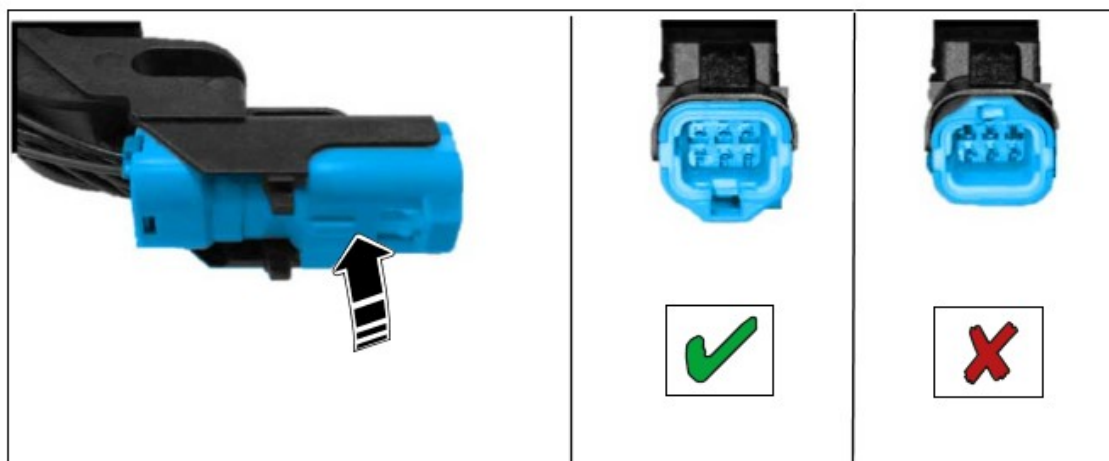

E211516

Clip the electrical connector into the handle strap inner (✓).

11



E211519

Install the antenna and electronic unit into the handle strap inner; align the clip with the handle strap inner rib.

- Firmly press the electronic unit onto the handle strap inner; make sure the self adhesive tape makes good contact.

12



E211517

Remove and discard the white tape from the electronic unit.

13

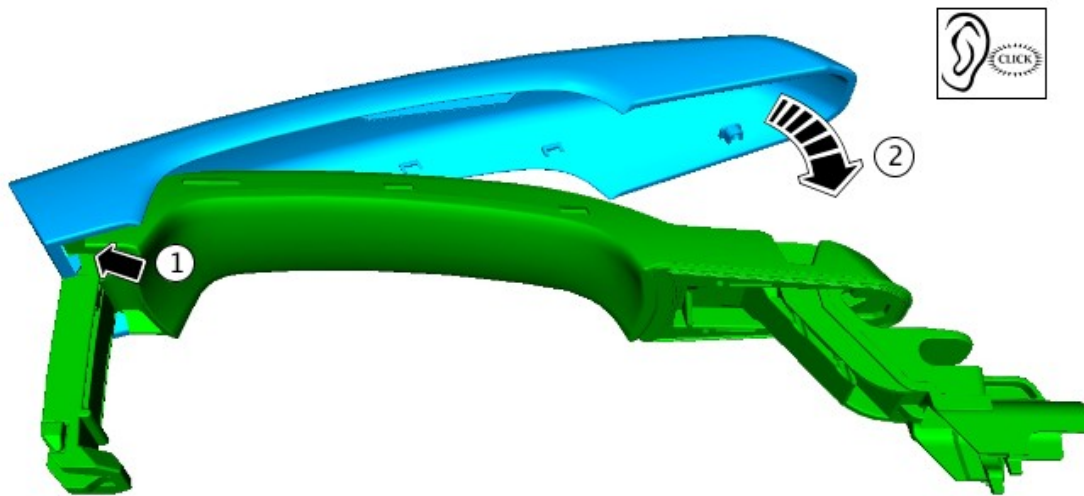

E222288

Assemble the inner and outer sections of the door exterior handle by clipping the 2 sections together.

- Hook the outer door handle cover around the end of the inner door handle strap **(1)**.
- Rotate the outer door handle cover about point **(1)** and clip the inner door handle strap into the outer door handle cover **(2)**.
- Firmly squeeze the door handle strap assembly at the electronic module end to make sure the self adhesive tape makes good contact with the handle strap inner and the handle cover.

14

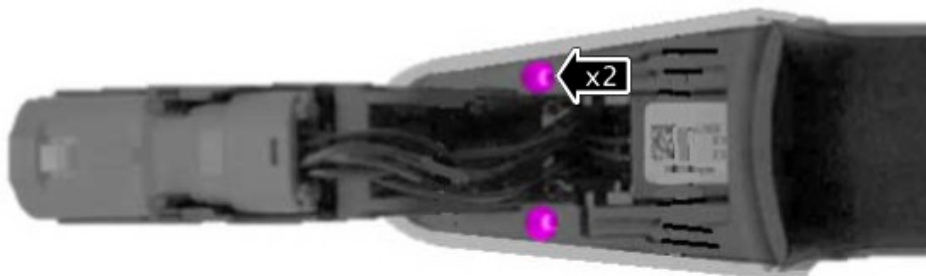

E211515

Install the 2 screws into the handle strap.

15

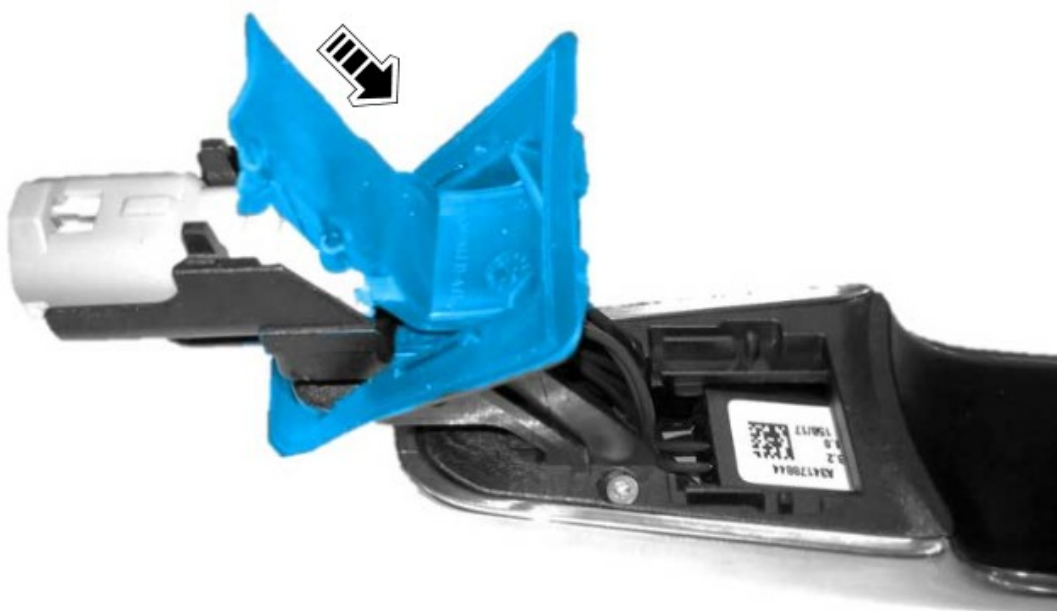

E212045

Start the installation of the door exterior handle gasket.

16

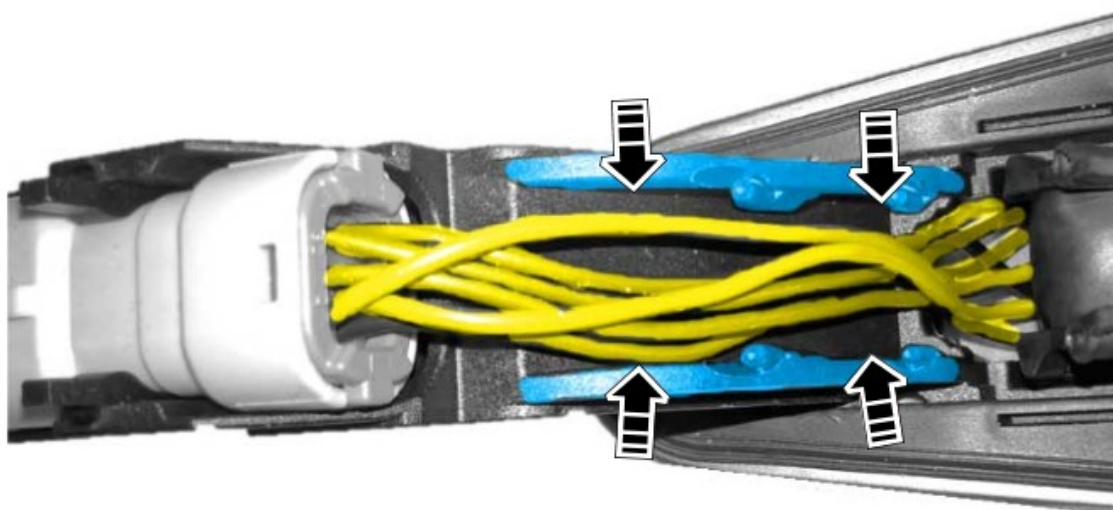

E212048

Make sure the wiring harness is positioned.

17

NOTE:

Make sure the gasket lies flat when it has been installed.

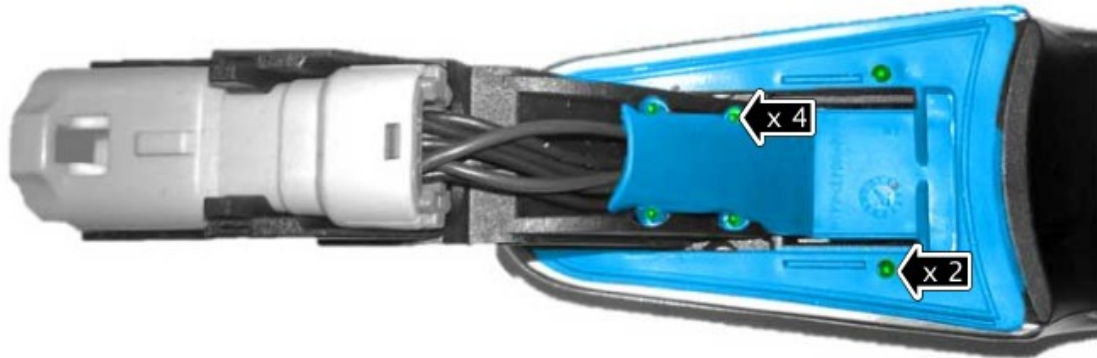

E212047

Install the rubber gasket onto the door exterior handle strap.

- Make sure the rubber gasket is installed over the 2 locating pins on the handle base.
- Make sure the rubber gasket is installed over the 4 locating pins, 2 either side of the wiring harness.



E212046

Make sure the rubber gasket sits flush against the handle base and the locating lug at the front of the gasket is installed into the hole in the handle (✓).

19 Repeat steps 7-18 for any remaining handles that require replacement.

20

NOTE:

Only complete this step if 1 or more front door exterior handles have been identified as part of the customer's concern.

Replace the defective front door exterior handle(s) (see TOPIx Workshop Manual section 501-14: Handles, Locks, Latches and Entry Systems - Exterior Front Door Handle).

21

NOTE:

Only complete this step if 1 or more rear door exterior handles have been identified as part of the customer's concern.

Replace the defective rear door exterior handle(s), (see TOPIx Workshop Manual section 501-14: Handles, Locks, Latches and Entry Systems - Exterior Rear Door Handle).

Odyssey Land Rover Technical Service Operations TSB Composition Log

Composed on:.....Tue Feb 06 14:18:35 GMT 2018

Composition Options Selected By User

Engine: xep

Include Illustrations: yes

Illustrations Format: svg

Proc Id on Footer: suppress

Graphic Quality: 300 dpi

Page Size: a4

Page Orientation: portrait

This page left intentionally blank

© Jaguar Land Rover Limited
All rights reserved.

Changes are highlighted in blue

This reissue replaces all previous versions. Please destroy all previous versions.

This bulletin supersedes TSB LTB01086/2017 dated 26 JUL 2017, which should either be destroyed or clearly marked to show it is no longer valid (e.g. with a line across the page). Only refer to the electronic version of this Technical Bulletin in TOPIx.

SECTION: 501-14

Keyless Entry Is Inoperative Or Intermittent

AFFECTED VEHICLE RANGE:

Range Rover Evoque (LV)

Model Year: 2012 Onwards
VIN: 600000 Onwards
Assembly Plant:Halewood

Range Rover Evoque (JV)

Model Year: 2016 Onwards
VIN: 000062 Onwards
Assembly Plant:Itatiaia (Brazil)

Range Rover Evoque (CV)

Model Year: 2015 Onwards
VIN: 100001 Onwards
Assembly Plant:Changshu

Range Rover Evoque (LV)

Model Year:2015 Onwards
VIN: 920000 Onwards

Discovery Sport (LC)

Model Year: 2015 Onwards
VIN: 501001 Onwards
Assembly Plant:Halewood

Discovery Sport (JC)

Model Year: 2016 Onwards
VIN: 200008 Onwards
Assembly Plant:Itatiaia (Brazil)

Discovery Sport (CC)

Model Year: 2015 Onwards
VIN: 300003 Onwards
Assembly Plant:Changshu

Discovery Sport (LC)

Model Year:2017 Onwards
VIN: 961561 Onwards

Range Rover (LG)

Model Year: 2013 Onwards
VIN: 000140 Onwards
Assembly Plant:Solihull

Range Rover Sport (LW)

Model Year: 2014 Onwards
VIN: 601621 Onwards
Assembly Plant:Solihull

Discovery (LR)

Model Year: 2017 Onwards
VIN: 000001 Onwards

Assembly Plant: Solihull

MARKETS:

ASIA PACIFIC; CHINA; EUROPE; JAPAN; MENA; OVERSEAS

CONDITION SUMMARY:

△ NOTE: Pune assembled vehicles are affected by this technical bulletin.

Situation: A customer may express a concern that the keyless entry 'lock' function may not operate or only operates intermittently. **This updated version has been issued due to changes to the affected vehicle range, parts, warranty and service instruction sections.**

Cause: Water ingress into the exterior door handles prevents correct operation of the keyless entry 'lock' function. **Suggested customer concern code - AK7.**

Action: Should a customer express concern, follow the service instruction below.

PARTS:

△ NOTE: Only order the quantity required for each vehicle repair.

△ NOTE: A maximum allowance equivalent to £50 sterling has been allocated to cover the cost of paint and materials (where door handle covers or inserts are supplied in primer).

Part Number	Description	Quantity
LR061200	Door handle exterior with primed cover (Dimple on handle)	4
LR040667	Door handle exterior with primed cover (Stripes on handle)	4
LR106320	Door handle exterior with primed insert (Dimple - Noble Chrome)	4
LR053502	Door handle exterior with primed insert (Dimple - Bright Chrome)	4
LR068146	Door handle exterior with primed insert (Dimple - Santorini Gloss black)	4
LR096116	Door handle exterior with primed insert (Dimple - Atlas Chrome)	4
LR055917	Door handle exterior - Chrome - Aintree Green	4
LR075119	Door handle exterior - Chrome - Aruba Gold	4
LR055923	Door handle exterior - Chrome - Barolo Black	4
LR055907	Door handle exterior - Chrome - Barossa	4
LR076447	Door handle exterior - Chrome - Carpathian Grey	4
LR055904	Door handle exterior - Chrome - Causeway Grey	4
LR056188	Door handle exterior - Chrome - Corris Grey	4
LR055914	Door handle exterior - Chrome - Firenze Red	4
LR055921	Door handle exterior - Chrome - Fuji White	4
LR055911	Door handle exterior - Chrome - Havana	4
LR055920	Door handle exterior - Chrome - Indus Silver	4
LR055913	Door handle exterior - Chrome - Kaikoura Stone	4
LR046326	Door handle exterior - Chrome - Loire Blue	4
LR055903	Door handle exterior - Chrome - Luxor	4

Part Number	Description	Quantity
LR055905	Door handle exterior - Chrome - Mariana Black	4
LR075120	Door handle exterior - Chrome - Montalcino Red	4
LR055906	Door handle exterior - Chrome - Nara Bronze	4
LR055916	Door handle exterior - Chrome - Santorini Black	4
LR067443	Door handle exterior - Chrome - Scotia Grey	4
LR072371	Door handle exterior - Chrome - Yulong White	4
LR013135	Trim panel clip 8.5 x 0.8 - 2.2	38
LR044885	Trim panel clip 8.2 x 1.2 + 2.5 clip	4
LR006101	Trim panel clip 8.2 x 0.7 - 1.5 clip	40
LR090382	Trim panel clip	4
ZZZ001	Paint and materials	1

WARRANTY:

△ **NOTE:** Repair procedures are under constant review, and therefore times are subject to change; those quoted here must be taken as guidance only. Always refer to JLR claims submission system to obtain the latest repair time.

△ **NOTE:** The JLR Claims Submission System requires the use of causal part numbers. Labor only claims must show the causal part number with a quantity of zero.

DESCRIPTION	SRO	TIME (HOURS)	CONDITION CODE	CAUSAL PART
Discovery (L462) - Handle - Exterior - Front door - Single - Renew	76.58.07	1.1	49	LR061200
Discovery (L462) - Handle - Exterior - Front door - Pair - Renew	76.58.46	2.2	49	LR061200
Discovery (L462) - Handle - Exterior - Rear door - Single - Renew	76.58.02	0.6	49	LR061200
Discovery (L462) - Handle - Exterior - Rear door - Pair - Renew	76.58.47	1.2	49	LR061200
Discovery Sport (L550) - Handle - Exterior - Front door - Single - Renew	76.58.07	0.7	49	LR061200
Discovery Sport (L550) - Handle - Exterior - Front door - Pair - Renew	76.58.46	1.4	49	LR061200
Discovery Sport (L550) - Handle - Exterior - Rear door - Single - Renew	76.58.02	0.5	49	LR061200
Discovery Sport (L550) - Handle - Exterior - Rear door - Pair - Renew	76.58.47	1.0	49	LR061200
Evoque (L538) - Handle - Exterior - Front door - Single - Renew	76.58.07	0.5	49	LR061200
Evoque (L538) - Handle - Exterior - Front door - Pair - Renew	76.58.46	1.0	49	LR061200
Evoque (L538) - Handle - Exterior - Rear door - Single - Renew	76.58.02	0.4	49	LR061200

Evoque (L538) - Handle - Exterior - Rear door - Pair - Renew	76.58.47	0.8	49	LR061200
Range Rover (L405) - Handle - Exterior - Front door - Single - Renew	76.58.07	0.6	49	LR061200
Range Rover (L405) - Handle - Exterior - Front door - Pair - Renew	76.58.46	1.2	49	LR061200
Range Rover (L405) - Standard wheelbase - Handle - Exterior - Rear door - Single - Renew	76.58.02	0.5	49	LR061200
Range Rover (L405) - Standard wheelbase - Handle - Exterior - Rear door - Pair - Renew	76.58.47	1.0	49	LR061200
Range Rover (L405) - Long wheelbase - Handle - Exterior - Rear door - Single - Renew	76.58.02	0.9	49	LR061200
Range Rover (L405) - Long wheelbase - Handle - Exterior - Rear door - Pair - Renew	76.58.47	1.8	49	LR061200
Range Rover Sport (L494) - Handle - Exterior - Front door - Single - Renew	76.58.07	0.7	49	LR061200
Range Rover Sport (L494) - Handle - Exterior - Front door - Pair - Renew	76.58.46	1.4	49	LR061200
Range Rover Sport (L494) - Handle - Exterior - Rear door - Single - Renew	76.58.02	0.5	49	LR061200
Range Rover Sport (L494) - Handle - Exterior - Rear door - Pair - Renew	76.58.47	1.0	49	LR061200
Door handles - Each/set - Local color	79.E.AJ3	0.6	49	LR061200
Exterior Door Handle Kit - Single - Assemble	76.58.89.38	0.1	49	LR061200
Exterior Door Handle Kit - Pair - Assemble	76.58.89.36	0.1	49	LR061200
Exterior Door Handle Kit - Set of 4 - Assemble	76.58.89.37	0.3	49	LR061200

△ **NOTE:** Normal Warranty procedures apply.

SERVICE INSTRUCTION:

1. △ **NOTE:** Driver door handle is shown, passenger door handles are similar.

Inspect the type of exterior door handle(s) that are to be replaced to make sure the correct replacement handle is ordered for the vehicle. Refer to the illustration for the different handle types.

1. Shows the dimple type handle.
2. Shows the stripe type handle.
3. Shows the chrome type handle.

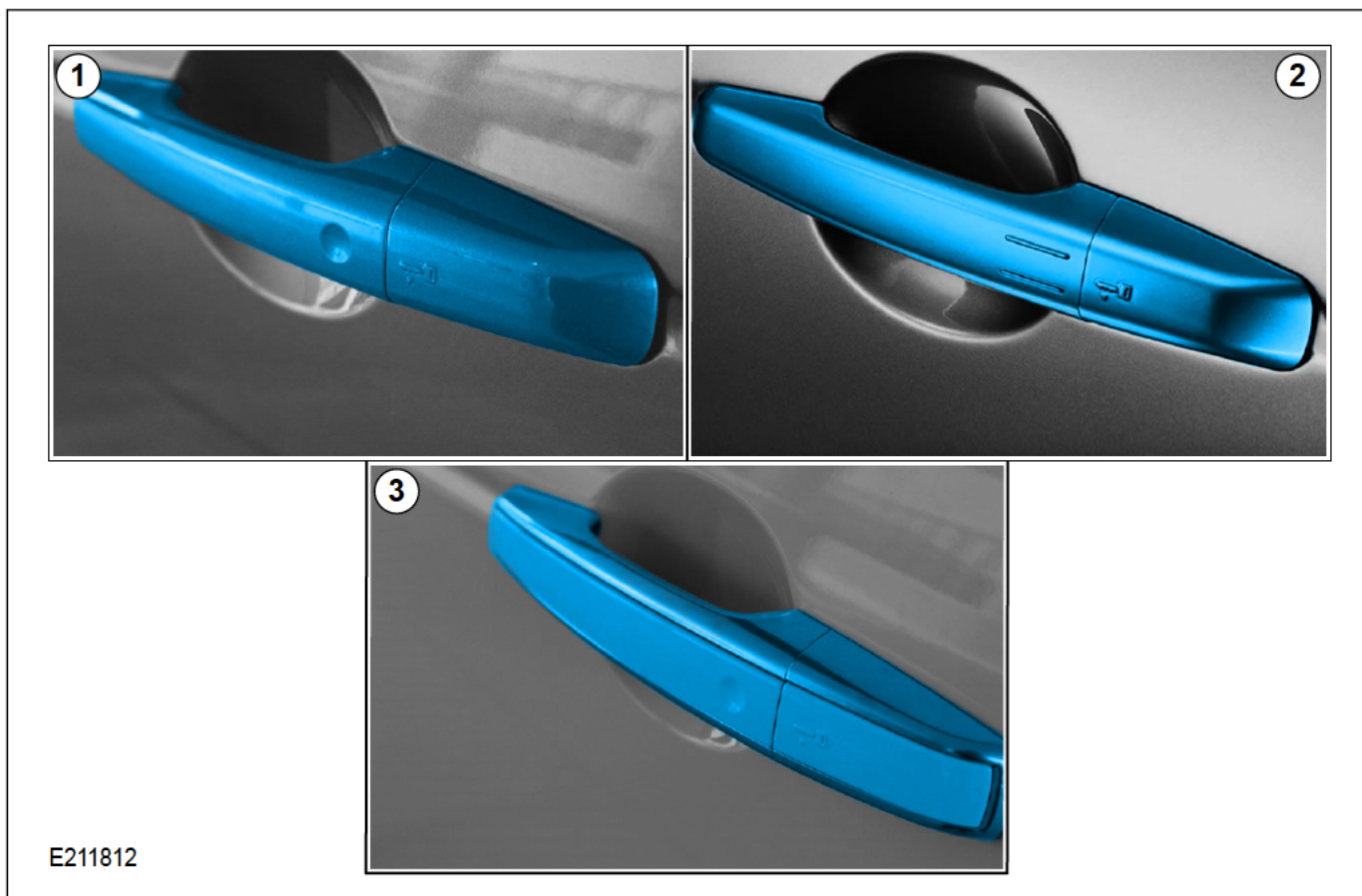

E211812

2. Locate the replacement exterior door handle(s) and inspect the gasket on the rear of the handle(s) for the production date.

1. The label shows the production day and month. In this instance 31/1 represents 31st January.
2. Peel the label back to check the production year stamp.
3. The stamp shows the production year in the center. In this instance 17 represents 2017.
 - If the production date is 03/08/2017 (3rd August 2017) or later, **continue to step 4.**
 - If the production date is 02/08/2017 (2nd August 2017) or earlier, **continue to step 3.**

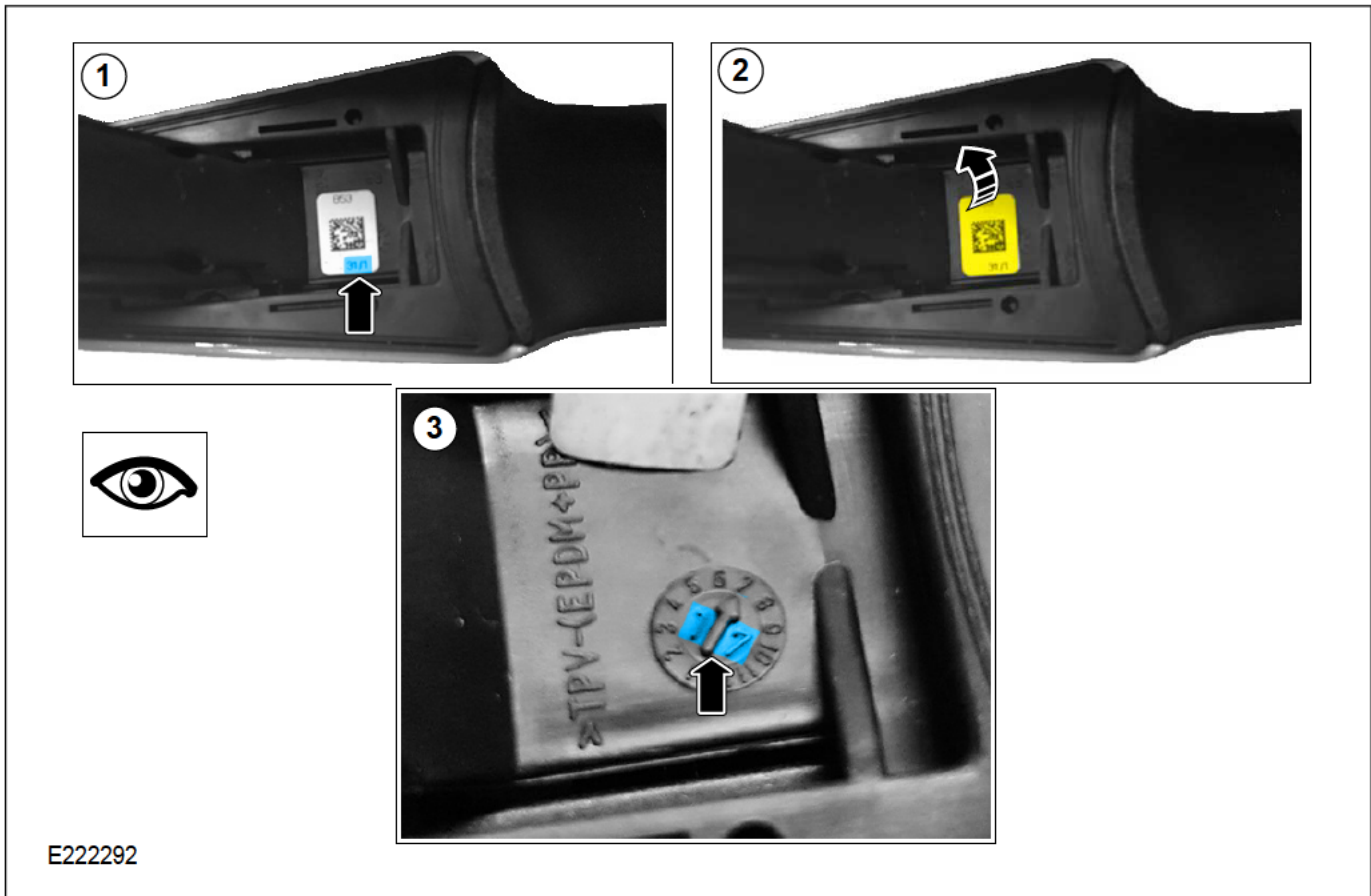

3. Inspect the marking(s) on the replacement exterior door handle(s).

- If the new exterior door handle(s) have the horizontal markings (1), this denotes that the handles are supplied pre-assembled. **Continue to step 4.**
- If the new exterior door handle(s) have the vertical markings (2), this denotes that the handles are supplied in kit form. **Continue to step 4.**
- If the new exterior door handle(s) have neither of the above markings and have a production date of 02/08/2017 or earlier, **DO NOT** use these parts. **Return the parts to the supplier and re-order new replacement exterior door handles and follow the steps above again.**

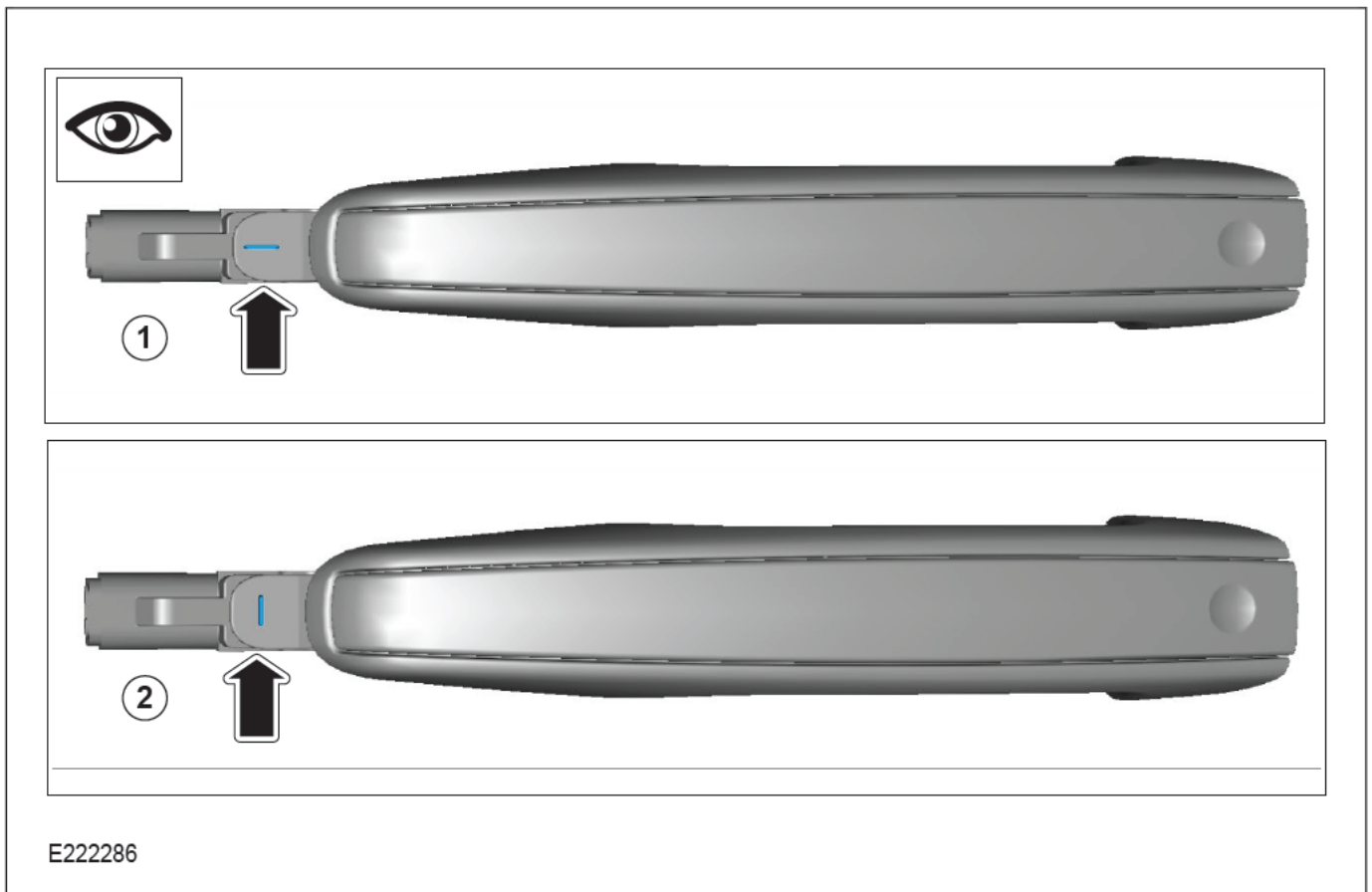

4. NOTE: The number of exterior door handles to be replaced will be dependant on the number identified as a concern by the customer.

Identify whether the exterior door handles require painting before they are installed.

- If the exterior door handle(s) are supplied in the correct color for the vehicle, **continue to step 20.**
- If the exterior door handle(s) are supplied pre-assembled partially in primer, where covers or inserts need painting in the correct color to match the vehicle, **continue to step 5.**
- If the exterior door handle(s) are supplied in kit form partially in primer, where the covers or inserts need painting in the correct color to match the vehicle, **continue to step 6.**

5. CAUTION: **DO NOT** dismantle pre-assembled exterior door handles before painting as this will cause damage to the weatherproof seals.

NOTE: This step is only applicable to pre-assembled exterior door handles that require painting.

Masking directions:

- For type (1) handles, mask the areas highlighted in blue. Part numbers: LR040667, LR061200.
- For type (2) handles, mask the areas highlighted in blue. Part numbers: LR0106320, LR053502, LR068146, LR096116.

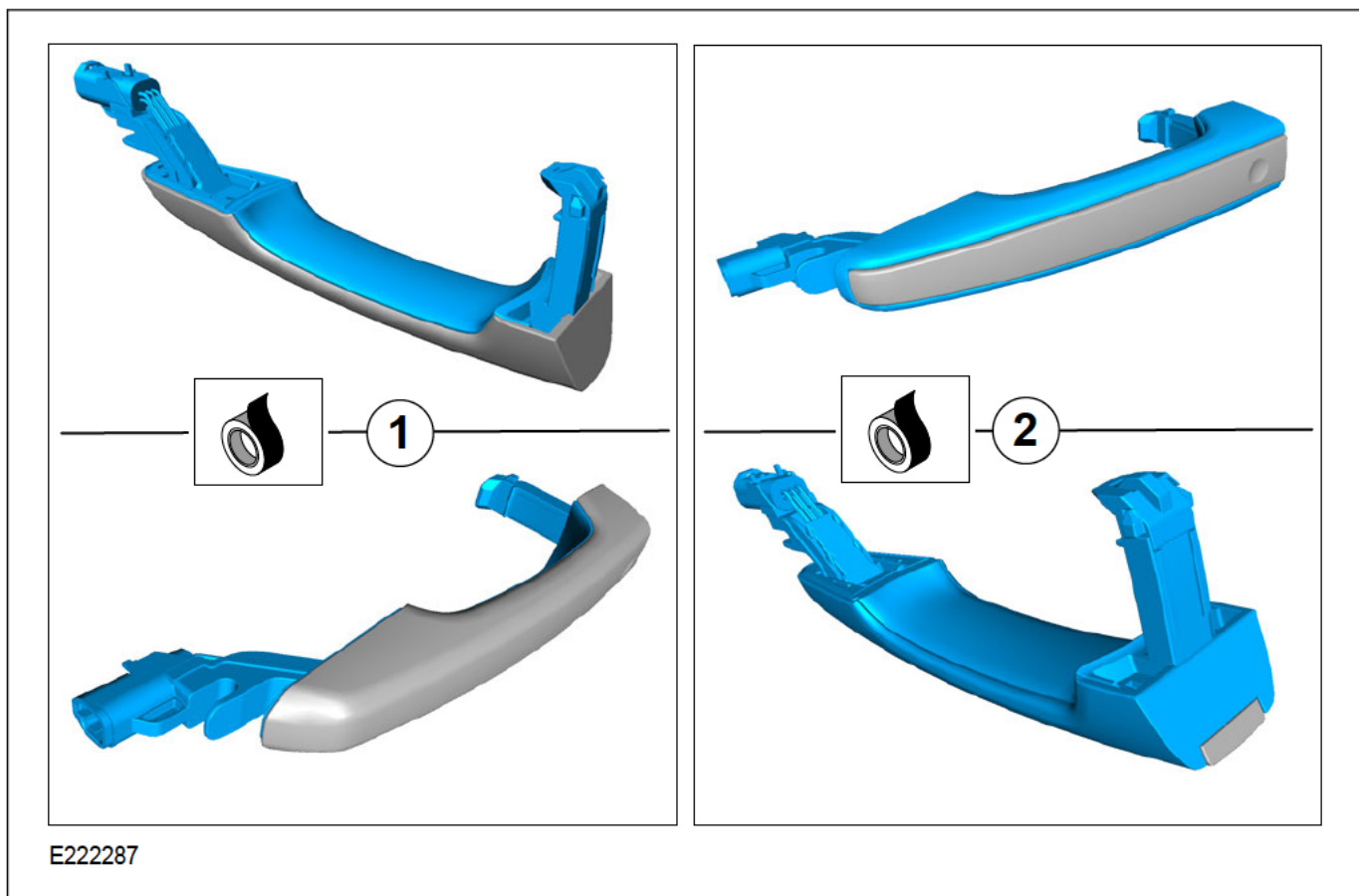

6. Paint the exterior door handle covers/inserts in the correct color to match the vehicle.

- For pre-assembled exterior door handles, allow the paint to dry then remove the masking tape and **continue to step 20.**
- For exterior door handles which were supplied in kit form, allow the paint to dry then **continue to step 7.**

7. △ **NOTE:** Only applicable to exterior door handles with painted inserts.

Install the painted exterior door handle insert into the exterior door handle cover (1).

- The painted exterior door handle insert is shown in the installed position (2).
- Viewed from the rear, make sure all the clips are engaged (3) and that the exterior door handle insert is securely installed.



8. Prepare the exterior door handle strap inner and electronic module for assembly.
- Remove the yellow backing from the tape on the electronic unit as illustrated.

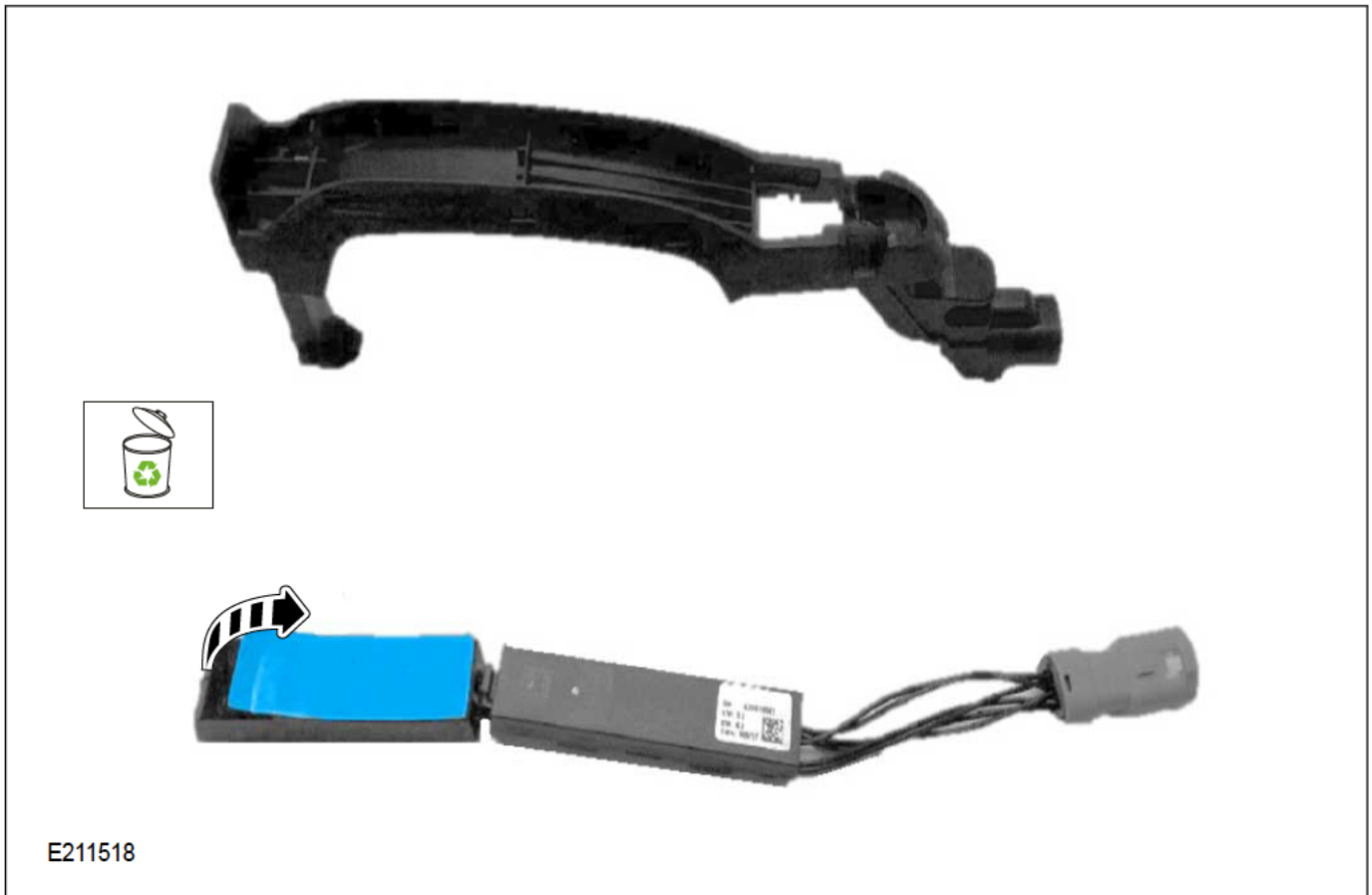

9. Insert the electrical connector through the exterior door handle strap inner as illustrated.

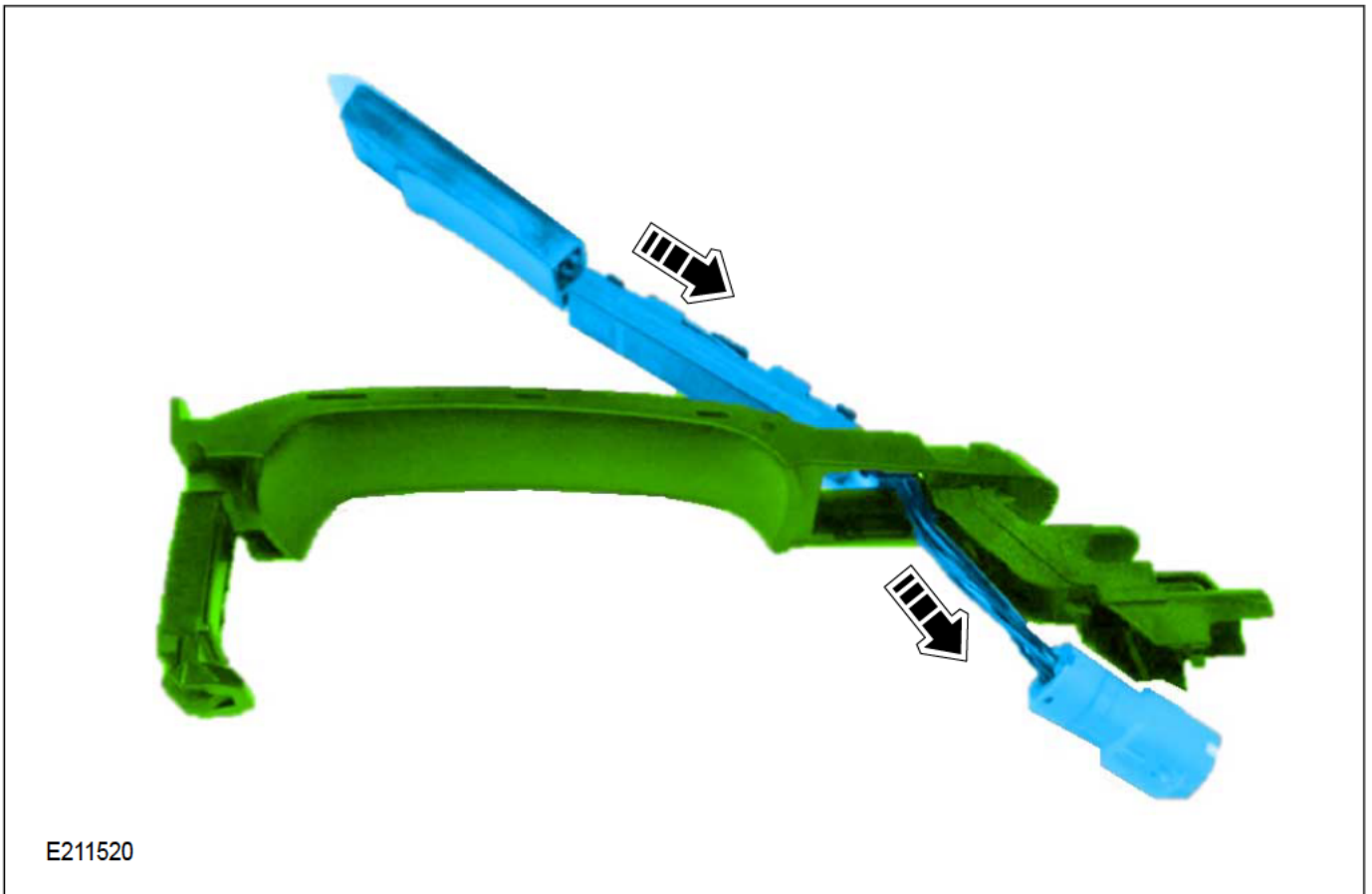

E211520

10.  NOTE: Make sure the electrical connector is correctly orientated.
Clip the electrical connector into the handle strap inner as illustrated.



11. Install the antenna and electronic unit into the handle strap inner, align the clip with the handle strap inner rib.
 - Firmly press the electronic unit onto the handle strap inner and make sure the self adhesive tape makes good contact.

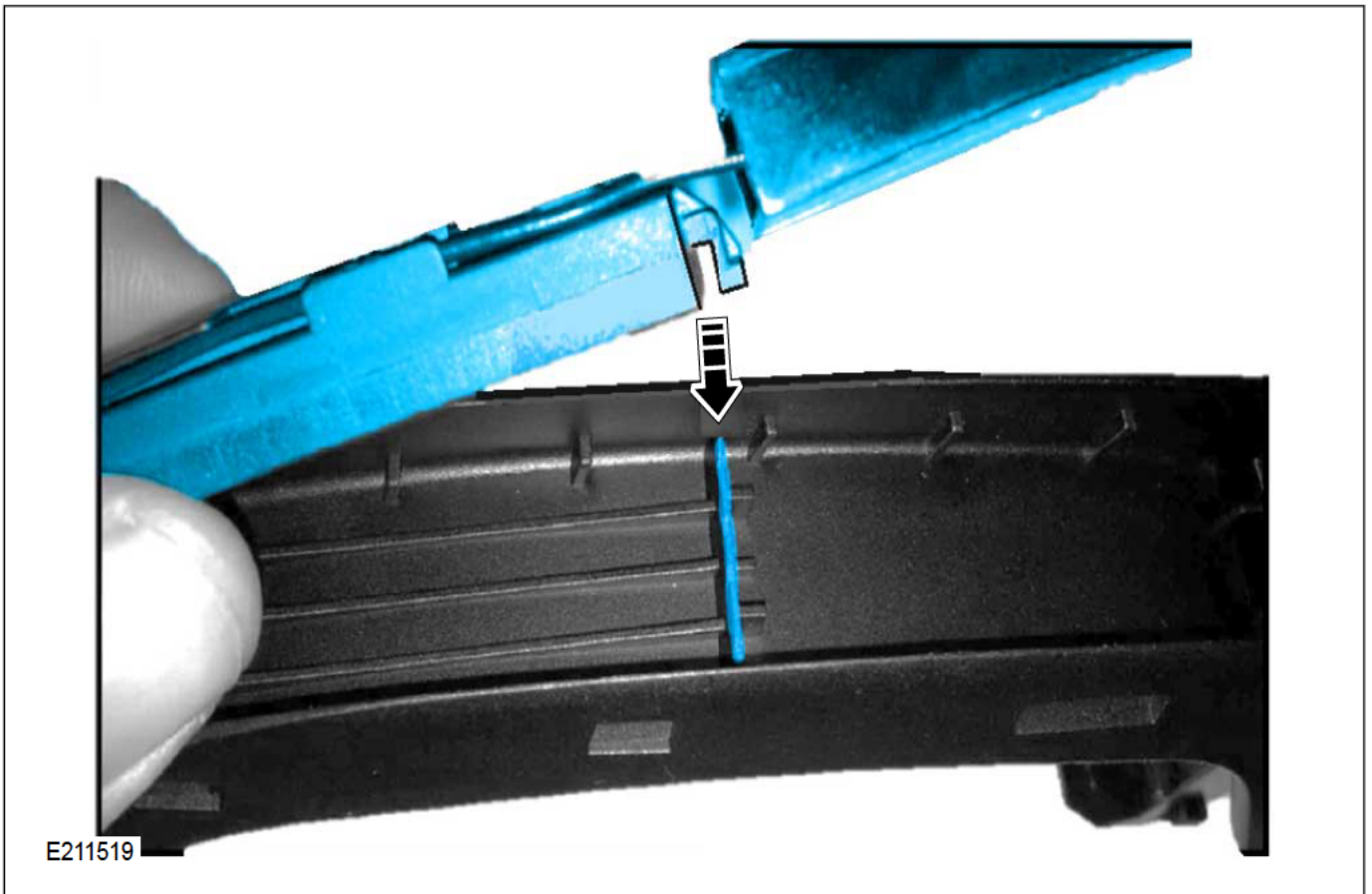

12. Remove the white tape from the electronic unit.



E211517

13. Assemble the inner and outer sections of the exterior door handle by clipping the 2 sections together as illustrated.

- Hook the outer door handle cover around the end of the inner door handle strap (1).
- Rotate the outer door handle cover about point (1) and clip the inner door handle strap into the outer door handle cover (2).
- Firmly squeeze the door handle strap assembly at the electronic module end to make sure the self adhesive tape makes good contact with the handle strap inner and the handle cover.

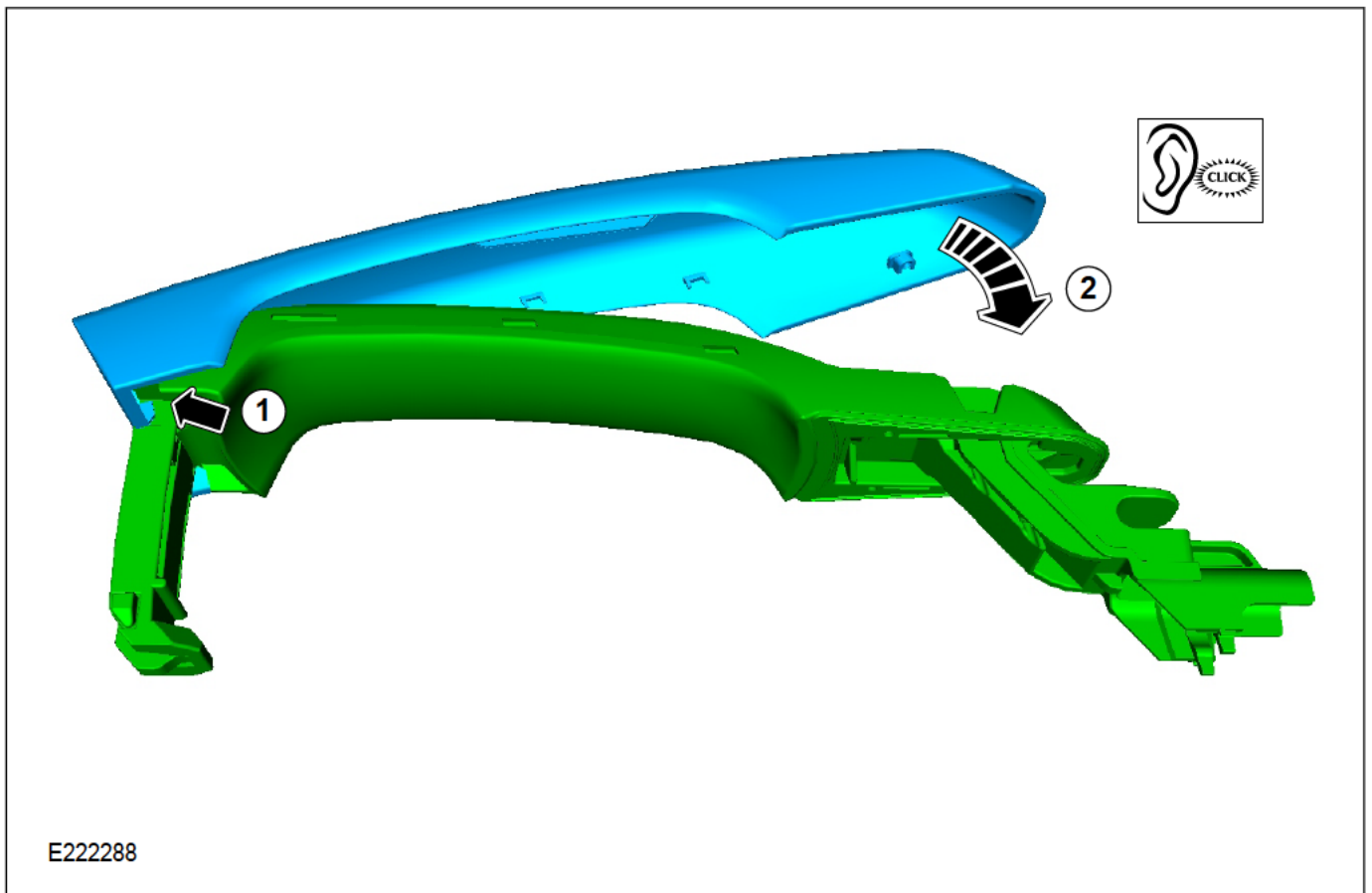

14. Install the 2 screws into the handle strap.

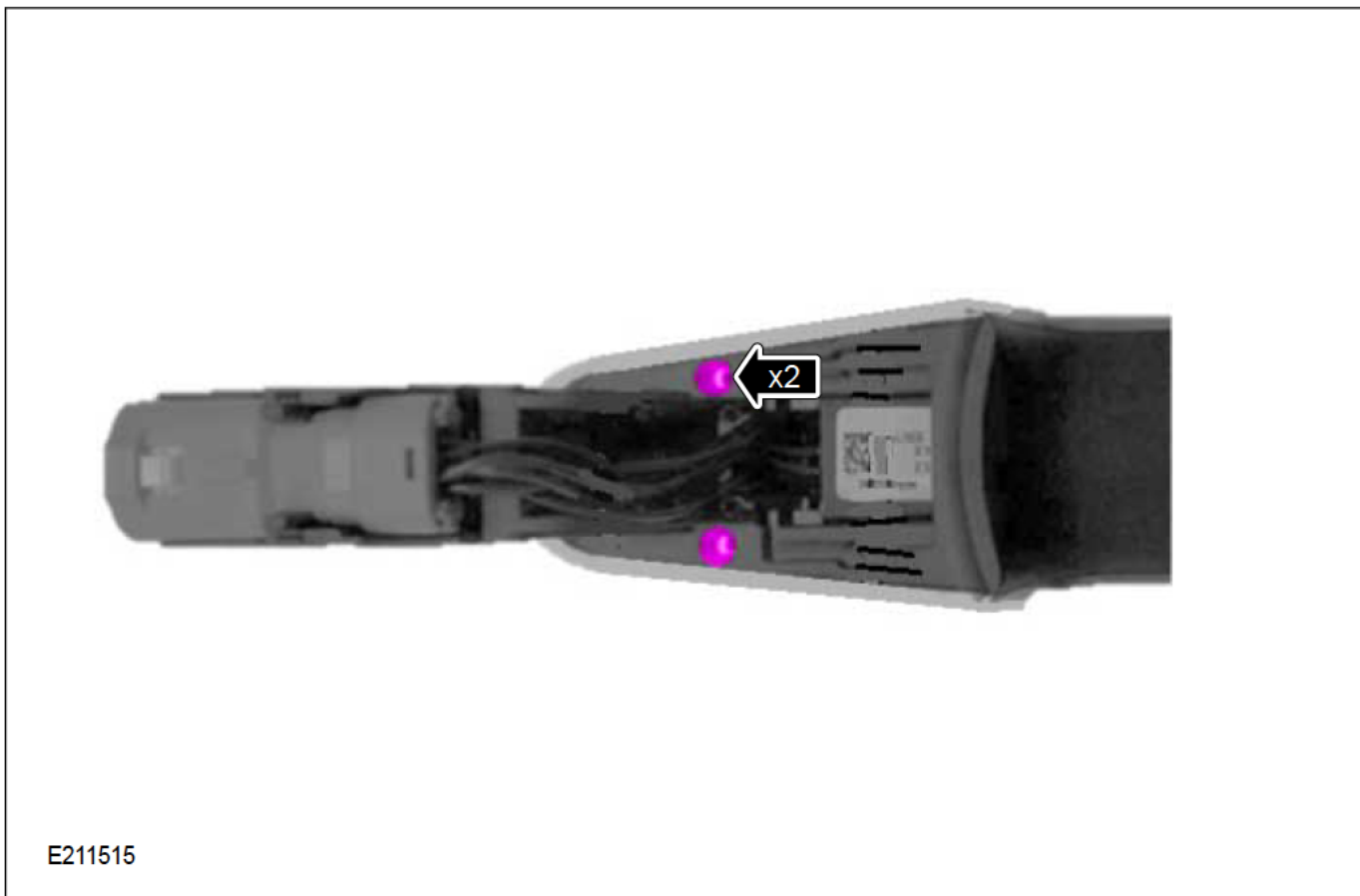

E211515

15. Start the installation of the exterior door handle gasket as illustrated.

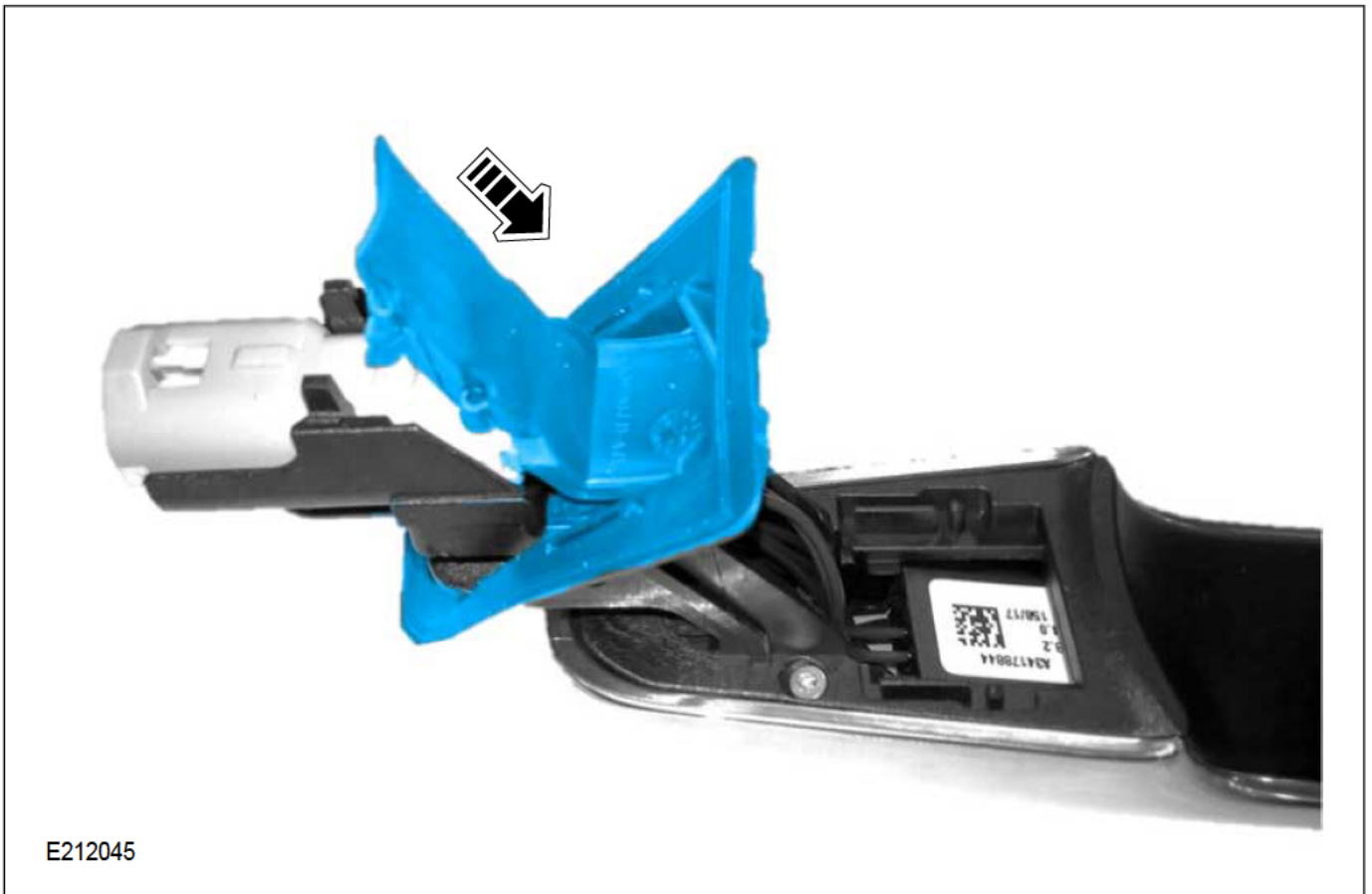

E212045

16. Make sure the wiring harness is positioned as illustrated.

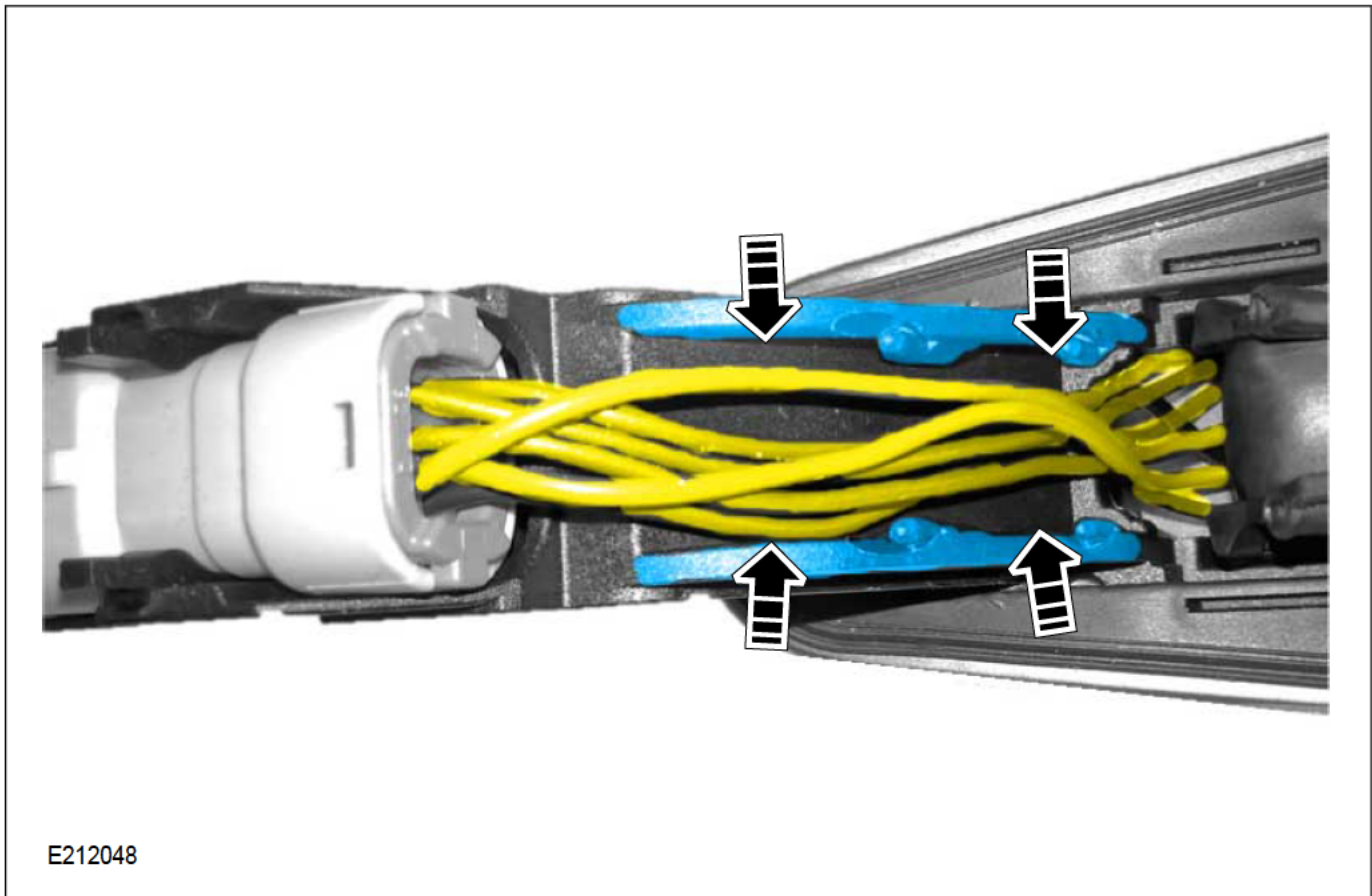

17.  NOTE: Make sure the gasket lies flat when it has been installed.

Install the rubber gasket onto the exterior door handle strap.

- Make sure the rubber gasket is installed over the 2 locating pins on the handle base as illustrated.
- Make sure the rubber gasket is installed over the 4 locating pins, 2 either side of the wiring harness.

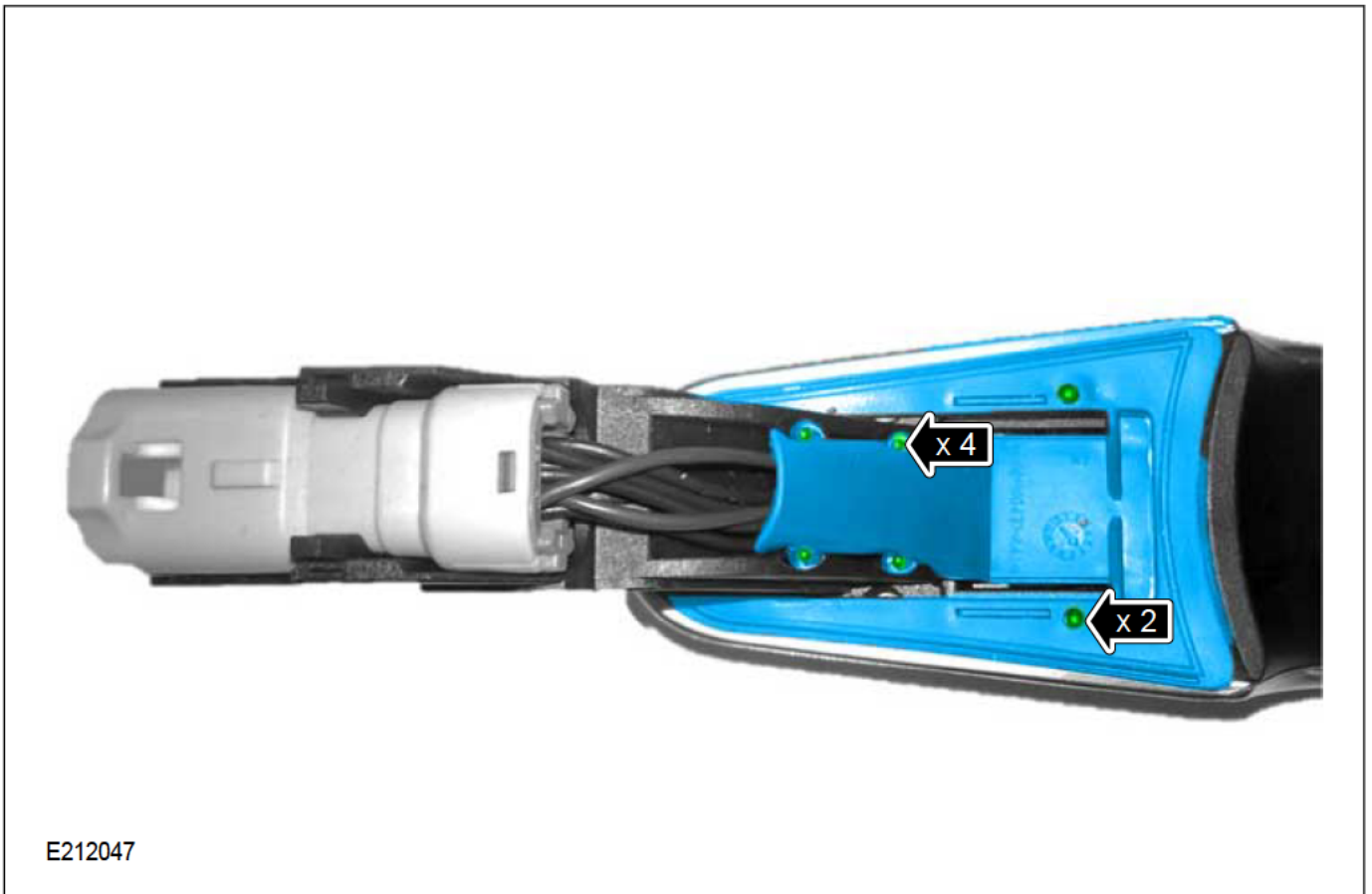

18. Make sure the rubber gasket sits flush against the handle base and the locating lug at the front of the gasket is installed into the hole in the handle.



E212046

19. Repeat steps 7 to 18 for any remaining handles that require replacement.

20.  NOTE: Only complete this step if 1 or more front exterior door handles have been identified as part of the customer's concern.

Replace the defective front exterior door handle(s), (see TOPIx Workshop Manual section: 501-14 - Exterior Front Door Handle).

21.  NOTE: Only complete this step if 1 or more rear exterior door handles have been identified as part of the customer's concern.

Replace the defective rear exterior door handle(s), (see TOPIx Workshop Manual section: 501-14 - Exterior Rear Door Handle).

LTB01172NAS1



TECHNICAL BULLETIN

21 SEP 2018

© Jaguar Land Rover North America, LLC

NOTE: The information in Technical Bulletins is intended for use by trained, professional Technicians with the knowledge, tools, and equipment required to do the job properly and safely. It informs these Technicians of conditions that may occur on some vehicles, or provides information that could assist in proper vehicle service. The procedures should not be performed by 'do-it-yourselfers'. If you are not a Retailer, do not assume that a condition described affects your vehicle. Contact an authorized Land Rover service facility to determine whether this bulletin applies to a specific vehicle.

SECTION:

501-14

SUBJECT/CONCERN:

Door Closing Motor Cable Disconnected

AFFECTED VEHICLE RANGE:

MODEL:	MODEL YEAR:	VIN:
Range Rover Sport (LW)	2018	165209-192513
Range Rover Sport (LW)	2018	691042-699998
Range Rover Sport (LW)	2018	400000-409626
Range Rover (LG)	2018	365394-391890

MARKETS:

NORTH AMERICA

CONDITION SUMMARY:**SITUATION:**

A front and/or rear door closing motor may not operate correctly, with one or more of the following issues present:

- The door does not open past the partial latch position.
- The door closing motor does not fully close the door but the motor can be heard running.
- The door does not fully close but does partially latch.

CAUSE:

These may be caused by internal failure of the door closing motor.

ACTION:

Should a customer express any of these concerns, refer to the Service Information and then follow the appropriate Workshop Procedure below.

PARTS:

PART NUMBER	DESCRIPTION	QUANTITY
LR117160	Front door closing motor	as required
LR117161	Rear door closing motor	as required

TOOLS:

Refer to Workshop Manual for any required special tools.

WARRANTY:

NOTES:

- Repair procedures are under constant review, and therefore times are subject to change; those quoted here must be taken as guidance only. Use TOPIx to obtain the latest repair time.
- The JLR claims submission system requires the use of causal part numbers. Labor only claims must show the causal part number with a quantity of zero.

DESCRIPTION	SRO	TIME (HOURS)	CONDITION CODE	CAUSAL PART
Closing motor cable - Release	76.37.89.58	0.1	42	LR108982
Door closing motor - Front - Renew	76.37.86	0.6	42	LR108982
Door closing motor - Front - Pair - Renew	76.37.03	1.2	42	LR108982
Door closing motor - Rear - Renew - Range Rover Sport (L494)	76.37.87	0.7	42	LR108982
Door closing motor - Rear - Pair - Renew - Range Rover Sport (L494)	76.37.04	1.4	42	LR108982
Door closing motor - Rear - Renew - Range Rover (L405)	76.37.87	0.9	42	LR108982
Door closing motor - Rear - Pair - Renew - Range Rover (L405)	76.37.04	1.6	42	LR108982

NOTE:

Normal Warranty procedures apply.

SERVICE INFORMATION:

CUSTOMER CONCERN	WORKSHOP PROCEDURE
Door does not open past the partial latch position	A
Door closing motor does not fully close the door but the motor can be heard running	B

CUSTOMER CONCERN	WORKSHOP PROCEDURE
Door does not fully close but does partially latch	B

WORKSHOP PROCEDURE 'A':

NOTE:

Rear right shown; all others similar.

1

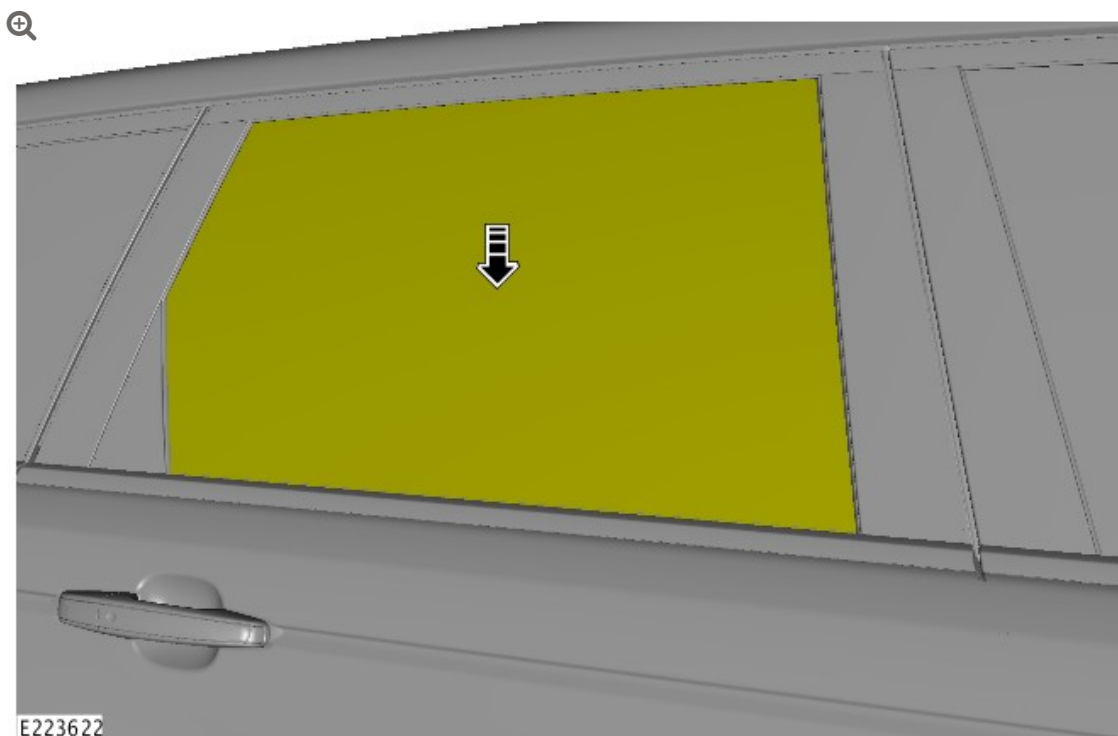

Lower the door window.

2

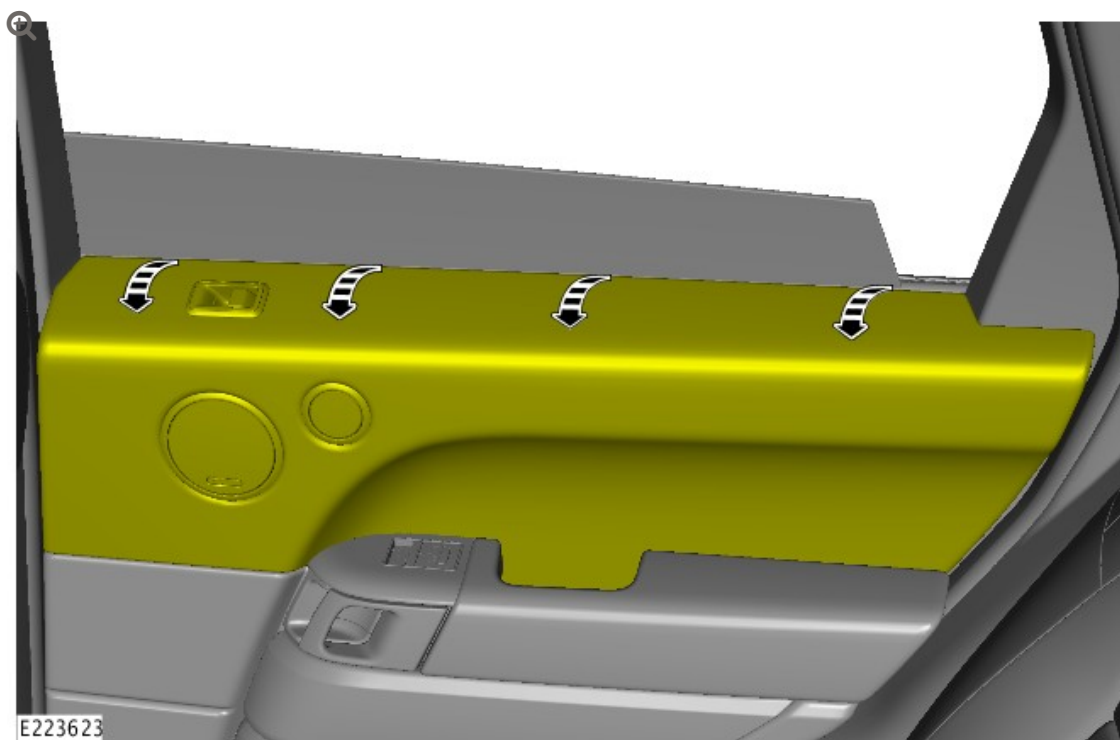

Carefully release the upper section of the interior door trim panel.

3

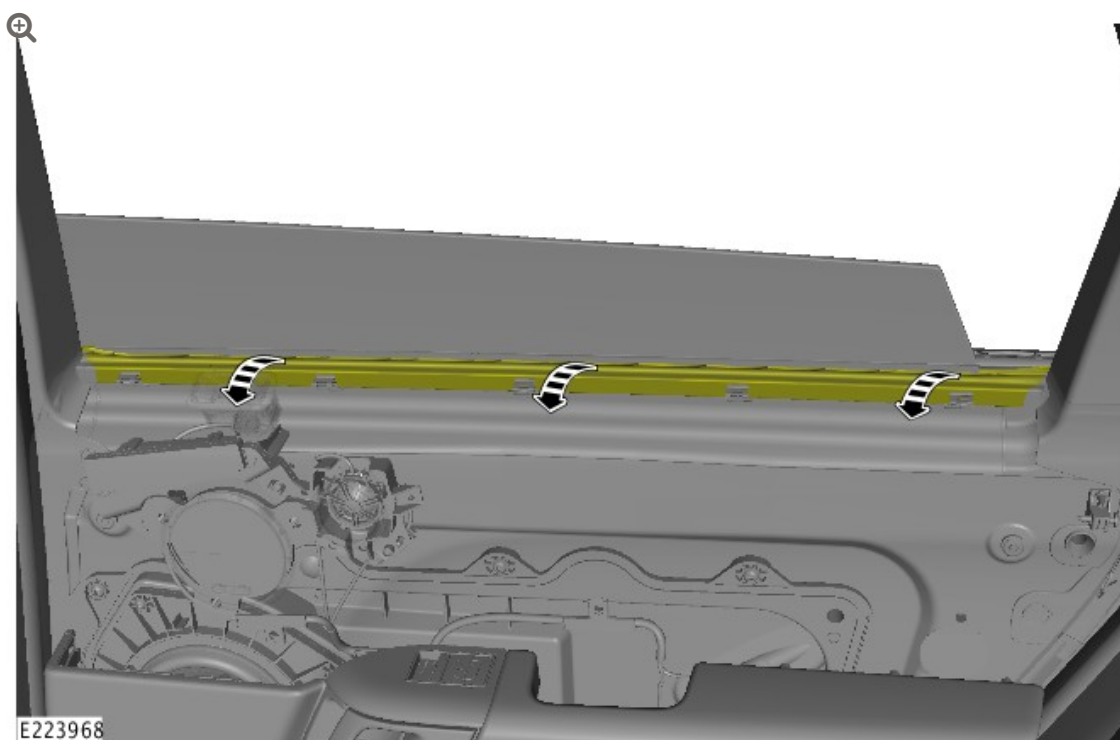

Carefully release the door window seal and position to the side.

4

NOTE:

Take care not to damage the bodywork or trim.

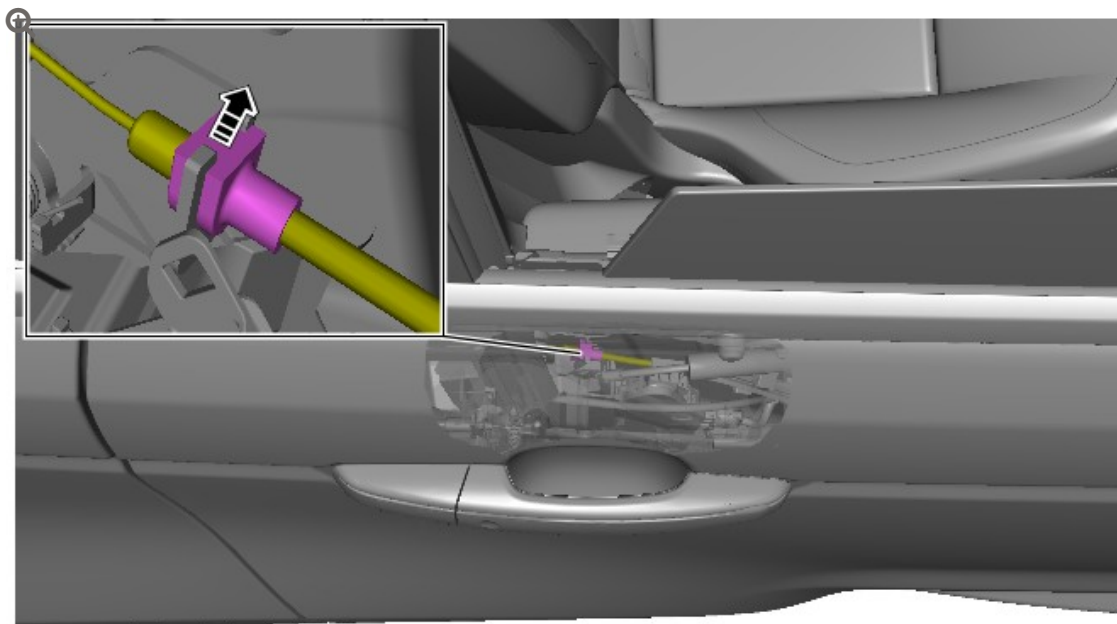

E223621

Use a suitable piece of wire to remove the door closing motor cable connector from the door latch.

5

NOTE:

Install the door window seal before installing the rear door trim panel.

Install a new door closing motor.

- **FRONT door:** see TOPIx Workshop Manual section 501-14: Handles, Locks, Latches and Entry Systems - Removal and Installation - Front Door Closing Motor.
- **REAR door:** see TOPIx Workshop Manual section 501-14: Handles, Locks, Latches and Entry Systems - Removal and Installation - Rear Door Closing Motor.

WORKSHOP PROCEDURE 'B':

1

NOTE:

Install the door window seal before installing the rear door trim panel.

Install a new door closing motor.

- **FRONT door:** see TOPIx Workshop Manual section 501-14: Handles, Locks, Latches and Entry Systems - Removal and Installation - Front Door Closing Motor.
- **REAR door:** see TOPIx Workshop Manual section 501-14: Handles, Locks, Latches and Entry Systems - Removal and Installation - Rear Door Closing Motor.

LTB01174NAS1



TECHNICAL BULLETIN

01 MAY 2018

© Jaguar Land Rover North America, LLC

NOTE: The information in Technical Bulletins is intended for use by trained, professional Technicians with the knowledge, tools, and equipment required to do the job properly and safely. It informs these Technicians of conditions that may occur on some vehicles, or provides information that could assist in proper vehicle service. The procedures should not be performed by 'do-it-yourselfers'. If you are not a Retailer, do not assume that a condition described affects your vehicle. Contact an authorized Land Rover service facility to determine whether this bulletin applies to a specific vehicle.

SECTION:

501-14: Handles, Locks, Latches and Entry Systems

SUBJECT/CONCERN:

Emergency Key Barrel Cover Adrift

AFFECTED VEHICLE RANGE:

MODEL:	MODEL YEAR:	VIN:	ASSEMBLY PLANT:
Discovery Sport (LC)	2017 Onwards	633943 Onwards	Halewood
Discovery (LR)	2017 Onwards	000532 Onwards	Solihull
Range Rover Evoque (LV)	2017 Onwards	168185 Onwards	Halewood
Range Rover Sport (LW)	2017 Onwards	124031 Onwards	Solihull
Range Rover Sport (LW)	2017-2018	666892-699998	Solihull
Range Rover Sport (LW)	2018 Onwards	400000 Onwards	Solihull
Range Rover (LG)	2017 Onwards	320324 Onwards	Solihull

MARKETS:NORTH AMERICA

CONDITION SUMMARY:**SITUATION:**

On vehicles with body color emergency key barrel covers, the cover in the driver's door exterior handle may become adrift.

NOTE:

This issue does not affect vehicles with chrome emergency key barrel covers.

CAUSE:

This may be caused by insufficient retaining features on the driver's door exterior handle gasket.

ACTION:

Should a customer express this concern, follow the Workshop Procedure below.

PARTS:**NOTE:**

An allowance of \$52.00 USD or local equivalent has been allocated to cover the cost of paint and materials. Claim using 'ZZZ001'.

PART NUMBER	DESCRIPTION	QUANTITY
LR117080	Front exterior door handle gasket	1
LR048299	Left Hand Drive (LHD) door handle cap	1
*ZZZ001	Paint materials	\$52.00 USD or local equivalent

WARRANTY:**NOTE:**

An allowance of \$52.00 USD or local equivalent has been allocated to cover the cost of paint and materials. Claim using 'ZZZ001'.

NOTES:

- Repair procedures are under constant review, and therefore times are subject to change; those quoted here must be taken as guidance only. Use TOPIx to obtain the latest repair time.
- The JLR claims submission system requires the use of causal part numbers. Labor only claims must show the causal part number with a quantity of zero.

DESCRIPTION	SRO	TIME (HOURS)	CONDITION CODE	CAUSAL PART
Front exterior door handle - Gasket - Renew - Discovery Sport (L550)	76.58.51	0.8	39	LR087704
Front exterior door handle - Gasket - Renew - Discovery (L462)	76.58.51	0.8	39	LR087704
Front exterior door handle - Gasket - Renew - Range Rover Evoque (L538)	76.58.51	0.5	39	LR087704
Front exterior door handle - Gasket - Renew - Range Rover Sport (L494), Range Rover (L405)	76.58.51	0.7	39	LR087704

NOTE:

Normal Warranty procedures apply.

WORKSHOP PROCEDURE:

This Workshop Procedure is applicable to the front left door only.

CAUTION:

Protect the surrounding paintwork to avoid damage.

- ¹ Remove the front left door exterior handle (see TOPIx Workshop Manual section: 501-14: Handles, Locks, Latches and Entry Systems - Removal and Installation - Exterior Front Door Handle).

²

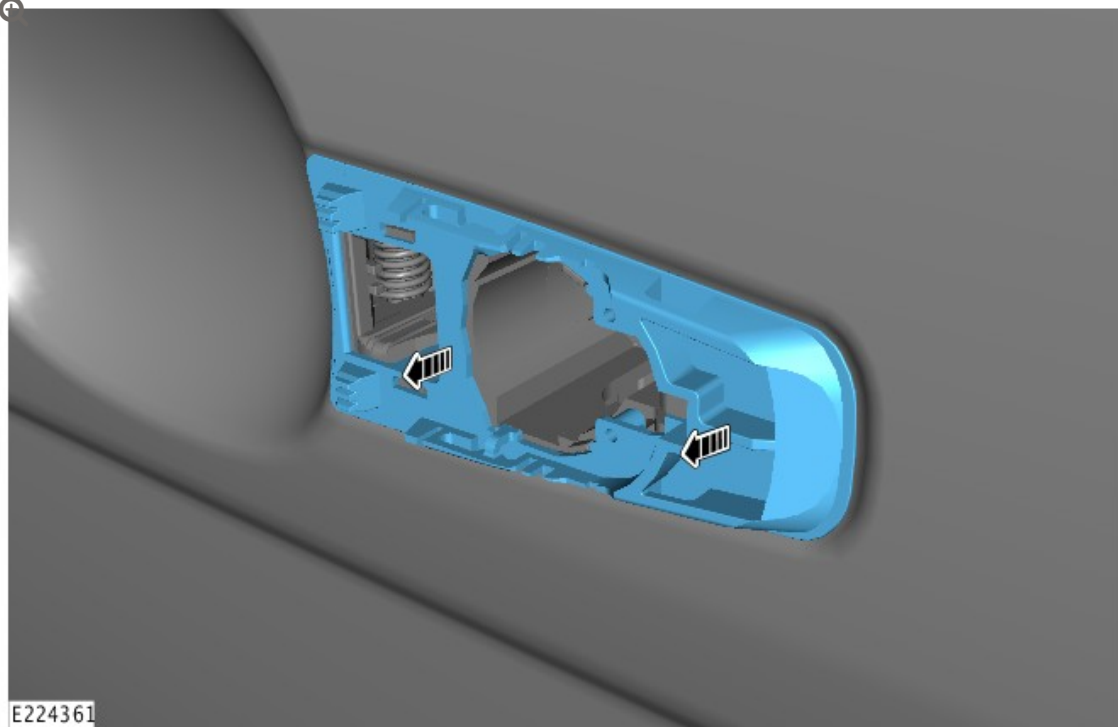

Remove the front left door exterior handle gasket.

³

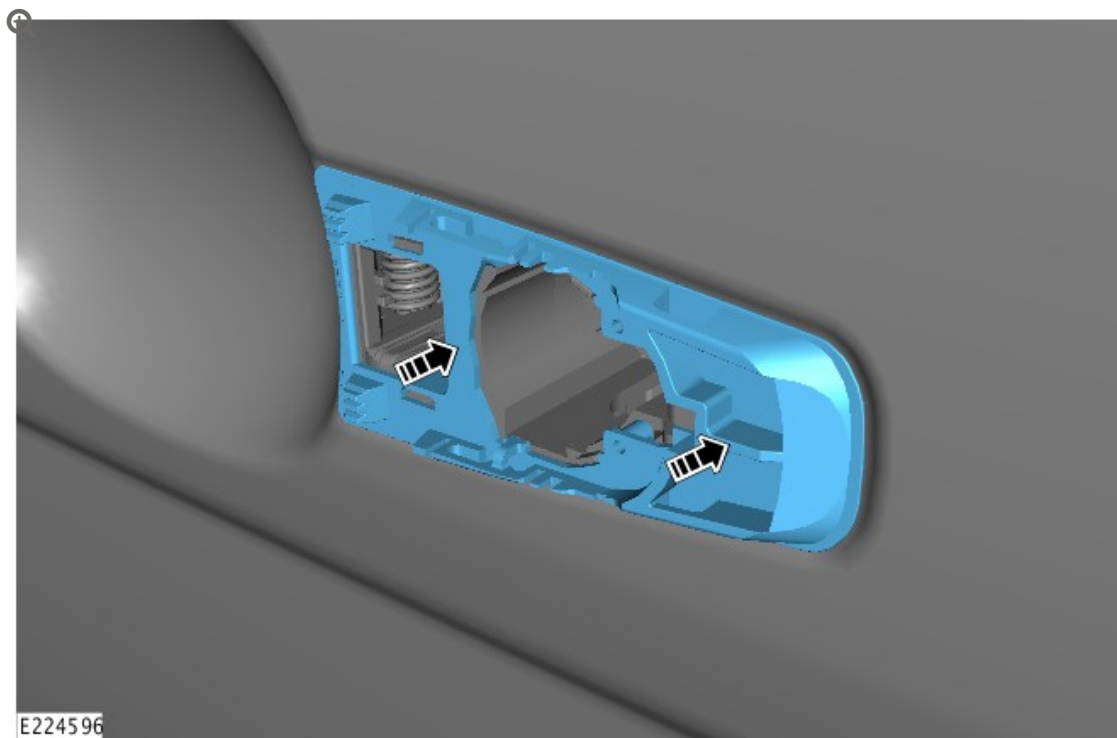

Install the new front left door exterior handle gasket.

-
- 4 Install the front left door exterior handle (see TOPIx Workshop Manual section: 501-14: Handles, Locks, Latches and Entry Systems - Removal and Installation - Exterior Front Door Handle).

5

NOTE:

The new emergency key barrel cover must be painted before installation.

Install the new emergency key barrel cover.



© Jaguar Land Rover North America, LLC

NOTE: The information in Technical Bulletins is intended for use by trained, professional Technicians with the knowledge, tools, and equipment required to do the job properly and safely. It informs these Technicians of conditions that may occur on some vehicles, or provides information that could assist in proper vehicle service. The procedures should not be performed by 'do-it-yourselfers'. If you are not a Retailer, do not assume that a condition described affects your vehicle. Contact an authorized Land Rover service facility to determine whether this bulletin applies to a specific vehicle.

SECTION: 01-14

Safety Recall: Vehicle Door Will Not Latch

AFFECTED VEHICLE RANGE:

Range Rover Sport (LW)

Model Year: 2014-2016

VIN: 000002-524031

VIN: 600000-620146

Range Rover (LG)

Model Year: 2013-2016

VIN: 000157-223025

MARKETS:

NAS

CONDITION SUMMARY:

Situation: A concern has been identified where customers have reported the door is unlatched when in the closed position and no indication provided of an unlatched condition. Some customers have reported that one door has opened while the vehicle was in motion.

Action: Retailers are required to **HOLD** only affected new vehicles that are within your control and refrain from releasing the vehicles for new or used vehicle sale pending completion of the rework action detailed in this Technical Bulletin. Unsold vehicles should have this performed as part of the Pre-Delivery Inspection (PDI) process but **must** have it completed prior to vehicle handover to the customer.

Affected vehicles already in the hands of customers should be updated at the next available opportunity.

PARTS:

No parts required

SPECIAL TOOLS:

SDD with latest SDD-DVD and Calibration File

Jaguar Land Rover-approved Idtronics Battery Power Supply

WARRANTY:



NOTE: check DDW to ensure that a vehicle is affected by this program prior to undertaking any rework action.

At the time of confirming a booking for vehicle repair, ensure that all outstanding Service Actions are identified to ensure the correct parts are available and adequate workshop time is allocated for repairs to be completed at one visit.

Warranty claims must be submitted quoting Program Code '**P068**' together with the relevant Option Code from the table. The SRO and part information listed have been included for information only. The Option Code(s) that allows for the drive in / drive out allowance may only be claimed if the vehicle is brought into the workshop for this action alone to be undertaken.

Repair procedures are under constant review, and therefore times / prices are subject to change; those quoted here must be taken as guidance only. Refer to TOPIx to obtain the latest repair time.

PROGRAM CODE	OPTION CODE	DESCRIPTION	SRO	TIME (HOURS)
P068	B	Configure existing keyless vehicle module	86.90.84	0.2
P068	C	Configure existing keyless vehicle module Drive in/Drive out	86.90.84 02.02.02	0.2 0.2

SERVICE INSTRUCTION:



CAUTION: a Jaguar Land Rover-approved Midtronics battery power supply must be connected to the vehicle battery during SDD diagnosis / module programming.



CAUTION: ensure all ignition 'ON' / ignition 'OFF' requests are carried out; failure to perform these steps may cause damage to control modules in the vehicle.



NOTE: SDD must be loaded with DVD142.4 v.213 or later.

1. Connect the Jaguar Land Rover-approved Midtronics battery power supply to the vehicle battery.
2. Turn ignition 'ON' (engine not running).
3. Connect the Symptom Driven Diagnostics (SDD) system to the vehicle and begin a new session.
4. Follow the on-screen prompts, allowing SDD to read the VIN and identify the vehicle and initiating the data collect sequence.
5. Select 'Diagnosis' from the Session Type screen.
6. Select the 'Selected Symptoms' tab, and then select the following:
 - Body > Security and locking > Handles locks and latches
7. From the Recommendations tab, select **Run** to perform the 'Configure existing module – Keyless vehicle module' option.
8. Follow all on-screen instructions to complete this task, ensuring all DTCs are cleared.
9. Exit the current session.
10. Disconnect the SDD and the battery power supply from the vehicle.

P068NAS2



TECHNICAL BULLETIN

29 JUL 2015

© Jaguar Land Rover North America, LLC

NOTE: The information in Technical Bulletins is intended for use by trained, professional Technicians with the knowledge, tools, and equipment required to do the job properly and safely. It informs these Technicians of conditions that may occur on some vehicles, or provides information that could assist in proper vehicle service. The procedures should not be performed by 'do-it-yourselfers'. If you are not a Retailer, do not assume that a condition described affects your vehicle. Contact an authorized Land Rover service facility to determine whether this bulletin applies to a specific vehicle.

INFORMATION

Changes are highlighted in blue

SECTION:

501-14

SUBJECT/CONCERN:

Safety Recall: Vehicle Door Will Not Latch

AFFECTED VEHICLE RANGE:

MODEL:	MODEL YEAR:	VIN:	ASSEMBLY PLANT:
Range Rover Sport (LW)	2014-2015	000002-524048	Solihull
Range Rover Sport (LW)	2015	600188-620146	Solihull
Range Rover Sport (LW)	2016	519971-523677	Solihull
Range Rover Sport (LW)	2016	617562-619695	Solihull
Range Rover (LG)	2013-2015	000157-223054	Solihull
Range Rover (LG)	2016	216961-222280	Solihull

MARKETS:

NAS

CONDITION SUMMARY:

SITUATION:

A concern has been identified where customers have reported the door is unlatched when in the closed position and no indication provided of an unlatched condition. Some customers have reported that one door has opened while the vehicle was in motion.

ACTION:

Retailers are required to **HOLD** only affected new vehicles that are within your control and refrain from releasing the vehicles for **new vehicle sale** pending completion of the Service Instruction detailed in this Technical Bulletin. Unsold vehicles should have this performed as part of the Pre-Delivery Inspection (PDI) process but **must** have it completed prior to vehicle handover to the customer.

Affected vehicles already in the hands of customers should be updated at the next available opportunity.

PARTS:

No parts required.

SPECIAL TOOLS:

NOTE:

this document is an 'Active Bulletin' that will display a functional programming shortcut if accessed within a diagnostic session using SDD.

- SDD with SPECIFIC SOFTWARE INSTALLED AS PER DETAILS WITHIN THIS DOCUMENT'S "SERVICE INSTRUCTIONS" SECTION

- Jaguar Land Rover-approved Midtronics Battery Power Supply

WARRANTY:

NOTE:

check DDW to ensure that a vehicle is affected by this program prior to undertaking any rework action.

At the time of confirming a booking for vehicle repair, ensure that all outstanding Service Actions are identified to ensure the correct parts are available and adequate workshop time is allocated for repairs to be completed at one visit.

Warranty claims must be submitted quoting Program Code '**P068**' together with the relevant Option Code from the table. SRO and parts information is included for information only. The Option Code(s) that allows for the drive in / drive out allowance can only be claimed if the vehicle is brought back into the workshop for this action alone to be undertaken.

Repair procedures are under constant review and therefore times / prices are subject to change; those quoted here must be taken as guidance only. Refer to TOPIx to obtain the latest repair time.

warranty claims must be submitted for payment within 30 calendar days of completion of the repair.

PROGRAM CODE	OPTION CODE	DESCRIPTION	SRO	TIME (HOURS)	PARTS/SUNDRY CODE	QTY./VALUE
P068	B	Configure existing keyless vehicle module	86.90.84	0.20	-	-
P068	C	Configure existing keyless vehicle module Drive in/drive out	86.90.84 02.02.02	0.20 0.20	- -	- -

Normal Warranty policies and procedures apply.

SERVICE INSTRUCTION:

NOTE:

the Manual Patch will only perform correctly when installed AFTER SDD142.04 v213 has already been installed. Also any future scheduled updates to SDD that advance the SDD software version OR calibration version BEYOND SDD142.04 v213 are expected to undo this manual patch.

This workaround will load a software file to SDD using the Manual Patch Update process. This Manual Patch will stay on the SDD machine until the next software update has been installed.

1 Make sure all communication devices are disconnected from the Symptom Driven Diagnostics (SDD) system.

2 Log in to SDD.

3 Select 'Continue' on the SDD Warning screen.

4 Select 'Settings' tab on the top right of the screen.

5 Select 'System Utilities' tab on the top middle of the screen.

6 Select 'Manual Patch Update'.

- A pop-up will be displayed for Manual patch selection dialog box.

7 Enter 'MP_L_L0002' in the Manual patch selection dialog box.

8 Select 'OK'.

9 The 'Software Management Wizard' will then download the fix file from the server.

10 Select 'OK' in the Manual patch update information pop up.

11 Select 'OK' when the message 'Please shut down SDD before continuing' is displayed. This is required because the update process has closed the 'JLR Application Launcher' and the SDD window needs to be closed.

- 'Please wait' message is displayed.

12 Select 'OK' when the 'Package has been installed' message is displayed.

- DO NOT SHUT DOWN THE PC, simply close the Internet Explorer window that is currently displaying the SDD Settings Tab screen you accessed in Step 6.

13 Select 'OK' in the Manual patch update information pop up.

14 Close the Internet Explorer Window where the SDD program runs.

15 Reboot the PC and attach a suitable label indicating its been prepped for P068, such as: "P068 Compatible Provided SDD142.04 v213 is currently installed."

- This PC can be returned to active service to support P068 with the specific instructions detailed in this documentation.

16 This PC can be returned to active service to support P068 with the specific instructions detailed in this documentation.

To complete P068 using a properly patched SDD unit:

17

CAUTIONS:

- a Jaguar Land Rover-approved Midtronics battery power supply must be connected to the vehicle battery during SDD diagnosis/module programming.
- ensure all ignition 'ON'/ignition 'OFF' requests are carried out; failure to perform these steps may cause damage to control modules in the vehicle.

NOTE:

SDD must be loaded with DVD142.04 v.213 or later.

Connect the Jaguar Land Rover-approved Midtronics battery power supply to the vehicle battery.

Click here to run the 'Configure existing module - Keyless vehicle module' option. (142.04 / 51250)

18 Turn ignition 'ON' (engine not running).

19 Connect the Symptom Driven Diagnostics (SDD) system to the vehicle and begin a new session.

20 Follow the on-screen prompts, allowing SDD to read the VIN and identify the vehicle and initiating the data collect sequence.

21 Select 'Diagnosis' from the Session Type screen.

22 Select the 'Selected Symptoms' tab, and then select the following:

- Body > Security and locking > Handles locks and latches

23 Read and close any publication from the list of recommended candidates to expose the 'Extras' tab.

24 Select the 'Extras' tab.

25 From the Recommendations tab, select **Run** to perform the 'Configure existing module - Keyless vehicle module' option.

26 Follow all on-screen instructions to complete this task, ensuring all DTCs are cleared.

27 Exit the current session.

28 Disconnect the SDD and the battery power supply from the vehicle.



P068NAS3

TECHNICAL BULLETIN

01 SEP 2015

© Jaguar Land Rover North America, LLC

NOTE: The information in Technical Bulletins is intended for use by trained, professional Technicians with the knowledge, tools, and equipment required to do the job properly and safely. It informs these Technicians of conditions that may occur on some vehicles, or provides information that could assist in proper vehicle service. The procedures should not be performed by 'do-it-yourselfers'. If you are not a Retailer, do not assume that a condition described affects your vehicle. Contact an authorized Land Rover service facility to determine whether this bulletin applies to a specific vehicle.

INFORMATION

Changes are highlighted in blue

SECTION:

501-14

SUBJECT/CONCERN:

Safety Recall: Vehicle Door Will Not Latch

AFFECTED VEHICLE RANGE:

MODEL:	MODEL YEAR:	VIN:	ASSEMBLY PLANT:
Range Rover Sport (LW)	2014-2015	000002-524048	Solihull

MODEL:	MODEL YEAR:	VIN:	ASSEMBLY PLANT:
Range Rover Sport (LW)	2015	600188-620146	Solihull
Range Rover Sport (LW)	2016	519971-523677	Solihull
Range Rover Sport (LW)	2016	617562-619695	Solihull
Range Rover (LG)	2013-2015	000157-223054	Solihull
Range Rover (LG)	2016	216961-222280	Solihull

MARKETS:

NAS

CONDITION SUMMARY:

SITUATION:

A concern has been identified where customers have reported the door is unlatched when in the closed position and no indication provided of an unlatched condition. Some customers have reported that one door has opened while the vehicle was in motion.

ACTION:

Retailers are required to **HOLD** only affected new vehicles that are within your control and refrain from releasing the vehicles for **new vehicle sale** pending completion of the Service Instruction detailed in this Technical Bulletin. Unsold vehicles should have this performed as part of the Pre-Delivery Inspection (PDI) process but **must** have it completed prior to vehicle handover to the customer.

Affected vehicles already in the hands of customers should be updated at the next available opportunity.

PARTS:

No parts required.

SPECIAL TOOLS:

 NOTE:

this document is an 'Active Bulletin' that will display a functional programming shortcut if accessed within a diagnostic session using SDD.

- SDD with latest SDD-DVD and Calibration File
- Jaguar Land Rover-approved Midtronics Battery Power Supply

WARRANTY:

 NOTE:

check DDW to ensure that a vehicle is affected by this program prior to undertaking any rework action.

At the time of confirming a booking for vehicle repair, ensure that all outstanding Recall and Service Actions are identified to ensure the correct parts are available and adequate workshop time is allocated for repairs to be completed at one visit.

Warranty claims must be submitted quoting Program Code '**P068**' together with the relevant Option Code from the table. SRO and parts information is included for information only. The Option Code(s) that allows for the drive in / drive out allowance can only be claimed if the vehicle is brought back into the workshop for this action alone to be undertaken.

Repair procedures are under constant review and therefore times / prices are subject to change; those quoted here must be taken as guidance only. Refer to TOPIx to obtain the latest repair time.

Warranty claims must be submitted for payment within 30 calendar days of completion of the repair.

PROGRAM CODE	OPTION CODE	DESCRIPTION	SRO	TIME (HOURS)	PARTS/SUNDRY CODE	QTY./VALUE
--------------	-------------	-------------	-----	--------------	-------------------	------------

P068	B	Configure existing keyless vehicle module	86.90.84	0.20	-	-
P068	C	Configure existing keyless vehicle module Drive in/drive out	86.90.84 02.02.02	0.20 0.20	- -	- -

Normal Warranty policies and procedures apply.

SERVICE INSTRUCTION:

1

CAUTIONS:

- a Jaguar Land Rover-approved Midtronics battery power supply must be connected to the vehicle battery during SDD diagnosis/module programming.
- ensure all ignition 'ON'/ignition 'OFF' requests are carried out; failure to perform these steps may cause damage to control modules in the vehicle.
- verify if vehicle is fitted with chrome exterior door handles and answer the pop-up appropriately.

NOTE:

SDD must be loaded with DVD142.06 v.215 or later. It is no longer necessary to perform the Manual Patch download described in P068NAS2.

Connect the Jaguar Land Rover-approved Midtronics battery power supply to the vehicle battery.

NOTE:

for vehicles fitted with DPLA (Gen II KVM), the correct software will display as 'Unknown'. Select '✓' to continue.

2 Turn ignition 'ON' (engine not running).

- 3 Connect the Symptom Driven Diagnostics (SDD) system to the vehicle and begin a new session.

- 4 Follow the on-screen prompts, allowing SDD to read the VIN and identify the vehicle and initiating the data collect sequence.

- 5 Select 'Diagnosis' from the Session Type screen.

- 6 Select the 'Selected Symptoms' tab, and then select the following:
 - Body > Security and locking > Handles locks and latches

- 7 From the Recommendations tab, select **Run** to perform the 'Configure existing module - Keyless vehicle module' option.

- 8 Follow all on-screen instructions to complete this task, ensuring all DTCs are cleared.

- 9 Exit the current session.

- 10 Disconnect the SDD and the battery power supply from the vehicle.

P068NAS3

TECHNICAL BULLETIN

01 SEP 2015



© Jaguar Land Rover North America, LLC

NOTE: The information in Technical Bulletins is intended for use by trained, professional Technicians with the knowledge, tools, and equipment required to do the job properly and safely. It informs these Technicians of conditions that may occur on some vehicles, or provides information that could assist in proper vehicle service. The procedures should not be performed by 'do-it-yourselfers'. If you are not a Retailer, do not assume that a condition described affects your vehicle. Contact an authorized Land Rover service facility to determine whether this bulletin applies to a specific vehicle.

INFORMATION

Changes are highlighted in blue

SECTION:

501-14

SUBJECT/CONCERN:

Safety Recall: Vehicle Door Will Not Latch

AFFECTED VEHICLE RANGE:

MODEL:	MODEL YEAR:	VIN:	ASSEMBLY PLANT:
Range Rover Sport (LW)	2014-2015	000002-524048	Solihull
Range Rover Sport (LW)	2015	600188-620146	Solihull
Range Rover Sport (LW)	2016	519971-523677	Solihull
Range Rover Sport (LW)	2016	617562-619695	Solihull
Range Rover (LG)	2013-2015	000157-223054	Solihull
Range Rover (LG)	2016	216961-222280	Solihull

MARKETS:

NAS

CONDITION SUMMARY:

SITUATION:

A concern has been identified where customers have reported the door is unlatched when in the closed position and no indication provided of an unlatched condition. Some customers have reported that one door has opened while the vehicle was in motion.

ACTION:

Retailers are required to **HOLD** only affected new vehicles that are within your control and refrain from releasing the vehicles for **new vehicle sale** pending completion of the Service Instruction detailed in this Technical Bulletin. Unsold vehicles should have this performed as part of the Pre-Delivery Inspection (PDI) process but **must** have it completed prior to vehicle handover to the customer.

Affected vehicles already in the hands of customers should be updated at the next available opportunity.

PARTS:

No parts required.

SPECIAL TOOLS:**NOTE:**

this document is an 'Active Bulletin' that will display a functional programming shortcut if accessed within a diagnostic session using SDD.

- SDD with latest SDD-DVD and Calibration File
- Jaguar Land Rover-approved Midtronics Battery Power Supply

WARRANTY:**NOTE:**

check DDW to ensure that a vehicle is affected by this program prior to undertaking any rework action.

At the time of confirming a booking for vehicle repair, ensure that all outstanding Recall and Service Actions are identified to ensure the correct parts are available and adequate workshop time is allocated for repairs to be completed at one visit.

Warranty claims must be submitted quoting Program Code '**P068**' together with the relevant Option Code from the table. SRO and parts information is included for information only. The Option Code(s) that allows for the drive in / drive out allowance can only be claimed if the vehicle is brought back into the workshop for this action alone to be undertaken.

Repair procedures are under constant review and therefore times / prices are subject to change; those quoted here must be taken as guidance only. Refer to TOPIx to obtain the latest repair time.

Warranty claims must be submitted for payment within 30 calendar days of completion of the repair.

PROGRAM CODE	OPTION CODE	DESCRIPTION	SRO	TIME (HOURS)	PARTS/SUNDRY CODE	QTY./VALUE
P068	B		86.90.84	0.20	-	-

PROGRAM CODE	OPTION CODE	DESCRIPTION	SRO	TIME (HOURS)	PARTS/SUNDRY CODE	QTY./VALUE
		Configure existing keyless vehicle module				
P068	C	Configure existing keyless vehicle module Drive in/drive out	86.90.84 02.02.02	0.20 0.20	- -	- -

Normal Warranty policies and procedures apply.

SERVICE INSTRUCTION:

¹

CAUTIONS:

- a Jaguar Land Rover-approved Midtronics battery power supply must be connected to the vehicle battery during SDD diagnosis/module programming.
- ensure all ignition 'ON'/ignition 'OFF' requests are carried out; failure to perform these steps may cause damage to control modules in the vehicle.
- verify if vehicle is fitted with chrome exterior door handles and answer the pop-up appropriately.

NOTE:

SDD must be loaded with DVD142.06 v.215 or later. It is no longer necessary to perform the Manual Patch download described in P068NAS2.

Connect the Jaguar Land Rover-approved Midtronics battery power supply to the vehicle battery.

NOTE:

for vehicles fitted with DPLA (Gen II KVM), the correct software will display as 'Unknown'. Select '✓' to continue.

- 2 Turn ignition 'ON' (engine not running).

- 3 Connect the Symptom Driven Diagnostics (SDD) system to the vehicle and begin a new session.

- 4 Follow the on-screen prompts, allowing SDD to read the VIN and identify the vehicle and initiating the data collect sequence.

- 5 Select 'Diagnosis' from the Session Type screen.

- 6 Select the 'Selected Symptoms' tab, and then select the following:
 - Body > Security and locking > Handles locks and latches

- 7 From the Recommendations tab, select **Run** to perform the 'Configure existing module - Keyless vehicle module' option.

- 8 Follow all on-screen instructions to complete this task, ensuring all DTCs are cleared.

- 9 Exit the current session.

- 10 Disconnect the SDD and the battery power supply from the vehicle.



RECALL ACTION

Recall Action
Number: P068v4

Subject: <h2 style="text-align: center;">Vehicle Door Will Not Latch</h2>	Publication No.: P068v4
	Model: Range Rover (LG)
	Model Year: 2013 - 2016
	Assembly Plant: Solihull
	VIN Range: 000001 - 001235
	Model: Range Rover (LG)
	Model Year: 2013 - 2016
	Assembly Plant: Solihull
	VIN Range: 100000 - 223058
	Model: Range Rover Sport (LW)
	Model Year: 2014 - 2016
	Assembly Plant: Solihull
	VIN Range: 600000 - 620148
	Model: Range Rover Sport (LW)
Model Year: 2014 - 2016	
Assembly Plant: Solihull	
VIN Range: 000001 - 001229	
Model: Range Rover Sport (LW)	
Model Year: 2014 - 2016	
Assembly Plant: Solihull	
VIN Range: 300000 - 524055	
Date of Issue: 21/10/2015	

To:	All National Sales Companies, Authorised Repairers and Importers (Excluding North America)
For the Attention of:	The Managing Director
Copies To:	The Service/Aftersales Director/Manager The Parts Director/Manager
Related information:	

Dear Colleagues

A concern has been identified where customers have reported the inability to secure the door in the closed position either on the primary or secondary latch. Some customers have reported that one of the vehicle doors has opened whilst the vehicle was in motion.

Vehicle doors not securely latched in the closed position may, during driving, open. This can increase the risk of a vehicle crash or compromise the safety of vehicle occupants.

Action to be taken

Jaguar Land Rover Limited has taken the decision to recall affected vehicles to download the latest software.

UK

Jaguar Land Rover Limited will be writing directly to customers with vehicles affected by this Recall requesting them to contact their preferred Authorised Repairer as soon as possible to arrange for the rework action to be carried out at the earliest opportunity. A copy of the customer letter is attached.

ROW

You are required to contact owners of affected vehicles, following procedures that are appropriate to your market and as required by local legislation; requesting that the owner contact their nearest authorised repairer, as soon as possible, to arrange for the software to be updated. A sample customer letter is attached; the letter should be adapted to the requirements of your market.

Please check DDW to ensure that the vehicle is affected by this Recall Action prior to undertaking any rework action. DDW will be updated to reflect only those vehicles affected. Should you require a listing of the affected vehicles in market, please contact the Land Rover Field Actions team by email at jlrcamp@jaguarlandrover.com. All overseas requests should be forwarded via the National Sales Company/Regional Office only

At the time of confirming a booking for vehicle repair, please ensure you check DDW and that all outstanding Field Service Actions are identified to ensure the correct parts are available and adequate workshop time is allocated for repairs to be completed at one visit.

For information purposes, a Technical Question and Answer document is attached.

Yours faithfully

Peter Cockle

Technical Director - Global Customer Service

Sample Customer Letter

Name

Address line 1

Address line 2

Address line 3

Post Code

Vehicle Identification Number (VIN):

Registration Number:

Programme Number: P068

Date: month/year

VOLUNTARY SAFETY RELATED RECALL - 2013 Model Year to 2016 Model Year Range Rover and Range Rover Sport Vehicles - Vehicle Door Will Not Latch

Dear

Jaguar Land Rover Limited would like to advise you that during ongoing quality assessment of our product it has been identified that a possible safety related problem may occur on certain Land Rover vehicles within a specific production range. Please read the information below, this will explain the actions that we intend to take and what you will need to do;

Reason for this programme

A concern has been identified where customers have reported the inability to secure the door in the closed position either on the primary or secondary latch. A small number of customers have reported that one of the vehicle doors has opened whilst the vehicle was in motion.

Vehicle doors not securely latched in the closed condition may, during driving, open, compromising the safety of vehicle occupants.

What Jaguar Land Rover Limited and your Land Rover authorised repairer will do

At your visit, your preferred Land Rover authorised repairer will download the latest software, and if required replace the Keyless Vehicle Module (KVM). If the Keyless Vehicle Module (KVM) is identified as requiring replacement, please ensure you bring all keys that are associated with the vehicle to your appointment.

How long will it take?

The work on your vehicle will be carried out as quickly and efficiently as possible in order to minimise inconvenience to you and will take approximately between twenty and forty five minutes to complete. However, due to your Land Rover authorised repairer schedules, your vehicle may be required for longer.

What we are asking you to do

Until such time as your vehicle is repaired Jaguar Land Rover strongly recommend that all vehicle occupants are secured using the vehicle seat belts and that the driver observe any door open warnings displayed in the instrument pack. Customers are advised to contact a Land Rover authorised repairer should they have any concerns regarding their vehicle. Please contact your preferred Land Rover authorised repairer without delay. To book your vehicle in for this action you will need to provide the authorised repairer with the following which are detailed at the beginning of this letter.

- The Vehicle Identification Number (VIN) for your vehicle.
- Vehicle registration number of your vehicle.
- The programme code for the action.

If you do not have an authorised repairer, please access www.landrover.co.uk or www.landrover.com for contact details.

If you no longer own the vehicle we would be grateful if you will complete the 'Change of Ownership' slip attached to this letter, returning the slip to Jaguar Land Rover Limited immediately in the enclosed 'Freepost' envelope. This will enable us to make contact with the new owner.

If you have concerns

If you experience any concerns relating to this Voluntary Recall, please contact the Service Manager at your authorised repairer for assistance or contact the Jaguar Land Rover Limited Customer Relationship Centre on 0370 5000 500 or (enter telephone number).

This Recall Action is being undertaken in accordance with the legislative or industry requirements concerning vehicle defects. The authorities will closely monitor the response rate of this Recall Action.

Please treat this matter with the urgency it requires. Jaguar Land Rover Limited apologises for any inconvenience this Voluntary Recall may cause and thank you, in advance, for your co-operation.

Yours sincerely

Land Rover Customer Service Director

Technical Questions And Answers	
FOR USE ON INQUIRY	
Jaguar Land Rover Recall P068	
Certain 2013 to 2016 Model Year Land Rover Range Rover vehicles and Certain 2014 to 2016 Model Year Land Rover Range Rover Sport vehicles – Vehicle Door may not Latch	

Main Message: A concern has been identified where customers have reported the door is unlatched when in the closed position and no indication provided of an unlatched condition. Some customers have reported that one door has opened while the vehicle was in motion. Vehicle doors not latched in either the primary or secondary state may, during driving, open. This can increase the risk of a vehicle crash or compromise the safety of vehicle occupants.

Question 1

Who do I contact if a member of the press contacts me about this recall?

Answer

Please ensure that any Press enquiries are referred to the Jaguar Land Rover Corporate Affairs office.

Question 2

Why is Jaguar Land Rover Limited recalling certain Land Rover vehicles?

Answer

Customers have reported doors opening whilst the vehicle is in motion and no warning of an unlatched condition on the instrument cluster. This is considered to be a safety issue and a recall is required to remedy the defect.

Question 3

Can you tell me more about what is wrong with the vehicles?

Answer

In late January 2015 an electrical system specification difference was identified where a short circuit was applied to the keyless vehicle release motor directly after energizing for a keyless vehicle passive entry actuation whereas the latch supplier specification stated a preference for open circuit. This short circuit effectively turns the motor into a brake, slowing or in some cases stopping the keyless vehicle lever from returning to its home position. If the keyless vehicle lever is held away from its home position then the pawl is constantly in a state of clearance to the claw – the claw is free to rotate, and release. This means that during a standard door closure operation the latch appears to take the striker and the door can be closed with the side of the vehicle but the door is not securely retained by the latch.

Question 4

How would the customer become aware of potentially having this concern?

Answer

It is possible that in the condition described, the door will not close and latch bouncing back so illuminating the door ajar switch. but there are cases where the door can appear closed although not latched at which point there is little obvious indication of the issue.

Question 5

Does this concern affect vehicle safety?

Answer

Yes, this recall is being conducted as the issue does pose a possible safety hazard.

Question 6

Has Jaguar Land Rover Limited received many complaints?

Answer

Jaguar Land Rover has received a number of customer complaints relating to this issue.

Question 7

Have there been any accidents or injuries or fires?

Answer

Jaguar Land Rover is unaware of any accident, injuries or fires which have been attributed to this issue.

Question 8

How was the condition discovered?

Answer

Jaguar Land Rover was alerted to this issue through retailer field reports.

Question 9

How long has Jaguar Land Rover known about this problem?

Answer

Jaguar Land Rover became aware of this issue in October 2014.

Question 10

Is the defect leading you to any concerns regarding the reliability of a system, which is supposed to be designed and engineered for the passengers' safety? What type of measures are you planning to take?

Answer

We have no concerns with the overall reliability of the vehicle. Jaguar Land Rover carefully monitors field data to ensure that any matters relating to safety and compliance are rigorously investigated.

Question 11

What has Jaguar Land Rover done in production?

Answer

Modifications have been made to remove the sensitivity of the door latch and associated mechanisms to the condition mentioned above.

Question 12

What is the repair for this issue?

Answer

Jaguar Land Rover will mail affected owners asking them to bring their vehicle to a Jaguar retailer of their choice to download the latest software making the motor open circuit in line with the latch manufacturers specification preference.

Question 13

Which vehicles are affected by this recall?

Answer

Certain 2013 to 2016 Model Year Land Rover Range Rover vehicles and certain 2014 to 2016 Model Year Land Rover Range Rover Sport vehicles built at the Solihull (UK) Assembly Plant from May 9, 2012 to March 12, 2015.

Question 14

Are other Jaguar Land Rover models affected by these actions?

Answer

No other models are known to be affected by this condition, other than those listed on this document.

Question 15

Are parts available to rework vehicles?

Answer

Parts are available for the rework.

Question 16

How much will the recall cost Jaguar Land Rover?

Answer

Cost was not a factor in deciding to recall these vehicles.

Question 17

How do I know if my Range Rover or Range Rover Sport vehicle is affected?

Answer

All owners of potentially affected vehicles will shortly receive a letter advising of this issue and requesting they make an appointment at the chosen Land Rover retailer for the repair to be completed.

Question 18

How long does it take for the vehicle to be inspected and repaired?

Answer

The work will be carried out as quickly and efficiently as possible in order to minimise inconvenience to customers and is expected to take no longer than between twenty and forty five minutes to complete. Naturally, due to retailer schedules, vehicles may be required for longer.

Question 19

Can I continue to drive my Land Rover vehicle safely until it has been recalled?

Answer

Until such time as your vehicle is repaired Jaguar Land Rover strongly recommend that all vehicle occupants are secured using the vehicle seat belts and that the driver observe any door open warnings displayed in the instrument pack.

Note: Please ensure that any Press enquiries are referred to the Jaguar Land Rover Corporate Affairs office.

SERVICE INSTRUCTION - P068v4

Parts Information

The parts below should be ordered through Land Rover Parts in the normal manner.

Description	Part No.	Qty	% of vehicles requiring this part*
Keyless Vehicle Module (KVM) - Passive Entry, Passive Start (PEPS)	LR071809	1	0.5



NOTE: * - when ordering parts, please order the expected percentage failure rate of parts identified only.

Warranty Information - SROs

Description	SRO	Time
Configure keyless vehicle module	86.90.84	0.2
Replace KVM module	86.80.08	0.7
Drive in/drive out	02.02.02	0.2

Warranty claims should be submitted quoting the program code P068 together with the relevant option code below. This will result in payment of the stated time and, where applicable, parts/miscellaneous expense codes.

Option Codes

Program Code	Option	Description	SRO	Time	Part No.	Qty
P068	B	Configure keyless vehicle module	86.90.84	0.2	n/a	n/a
P068	C	Configure keyless vehicle module Drive in/drive out	86.90.84 02.02.02	0.2 0.2	n/a	n/a
P068	F	Replace KVM module Configure keyless vehicle module	86.80.08 86.90.84	0.7 0.2	LR071809	1
P068	G	Replace KVM module Configure keyless vehicle module Drive in/drive out	86.80.08 86.90.84 02.02.02	0.7 0.2	LR071809	1



NOTE: The option that allows for the drive in/drive out allowance can only be claimed if the vehicle is brought back into the workshop for this action alone to be undertaken.

Warranty claims should be submitted in accordance with the current Jaguar Land Rover Warranty Policy and Procedures Manual and its amendments, unless stated otherwise in this Recall Action.

Important Information:

CAUTIONS:



Please refer to the VIN ranges detailed in the workshop procedure. If the KVM requires replacement then please make sure the following care points are followed.



Failure to follow these care steps can result in the application failing and the module becoming unusable.



There must be a minimum of two keys present before starting the application.



Make sure all existing keys are functioning correctly before the application is started. If not, this MUST be investigated and rectified, before continuing.



All keys must be labelled and numbered 1, 2, 3, 4, etc, before starting the workshop procedure.



The new KVM MUST be installed and connected.



The battery support unit must be connected to the vehicle.



SDD must be connected to the vehicle and a new session started.

After a new KVM has been installed in the vehicle, the ignition will NOT operate as normal until the keys have been programmed and verified. All SDD ignition prompts must be completed as instructed below:

- When the start/stop switch in the vehicle is pressed, the user will need to press the SDD on screen tick within 5 seconds. Failure to follow this instruction may result in part of the programming routine being repeated.



NOTE: This is normal behaviour for this application. The start/stop switch must be pressed to confirm that the vehicle is 'awake' and ready for programming. There is no need for the emergency Immobilizer Antenna Unit (IAU) start procedure to be used

When SDD instructs the user 'Set the ignition to ON (Position 2)' the user will need to press the start/stop switch. The Instrument Cluster (IC) will either:

1. Display a smart key warning message along with an audible tone.
2. Fully illuminate with the ignition lamps (battery warning light, engine malfunction indicator etc).

When SDD instructs the user 'Set the ignition to Off (Position 0)' then the user will need to check the IC to see if the ignition lamps are illuminated. The user will see either:

1. The ignition lights are already off; DO NOT press the start/stop switch on the vehicle, only follow the SDD on screen instructions.
2. The ignition lamps are illuminated (as per normal operation), press the start/stop switch to turn the ignition off before proceeding with the SDD on screen instructions.

Key Programming Care Points

- During the key programming application there are care points that must be followed to make sure the keys are successfully programmed to the vehicle.
- When SDD displays the message 'Make sure the key is inside the vehicle and the unlock button is pressed within 5 seconds after pressing tick', the key MUST remain in the vehicle.
- The key labelled as '1' should be held above the gear shift surround whilst the unlock button is pressed.
- This instruction may be repeated by SDD. There will be an audible tone when the key has been programmed.
- When SDD displays the message 'Have the next key ready', the key labelled '1' can be removed and the key labelled '2' can be put in the vehicle and the process repeated.
- Once all the keys have been programmed SDD will display 'Process completed', and move on to the key verification.

Workshop Procedure

1. NOTES:



You must complete the campaign P068 before attempting to run the Pre Delivery Inspection (PDI) or programming any keys to the vehicle.



Please be advised that you may see an 'Unknown' status on the software part confirmation screen. This is to be expected so select tick to proceed.



All existing keys and any new keys need to be present before continuing with the Workshop Procedure.



Some vehicles within the VIN ranges below may have had their KVM modules previously replaced with later hardware. It will not be possible to update the software on these later KVM modules. If SDD presents an error stating 'This application is not supported, contact dealer technical support' when the following application is run, then follow the instructions from Step 6 for vehicles that have had a previous KVM replacement.

Complete the instructions that are detailed in the P068 documentation.

For:

L405 VIN 000001 to 212942

L494 VIN 000001 to 516684

L494 VIN 600000 to 612444



2. **CAUTION:** This procedure requires SDD DVD142.06 and Calibration File 215 loaded.

If required, remove the transit relay.

1. Connect the JLR approved battery support unit.

3. Connect SDD to the vehicle and begin a new diagnostic session, SDD will read the correct VIN for the current vehicle.

4. Follow the SDD prompts.

- If the vehicle is in 'Transportation mode', set the vehicle to 'Normal operation mode'.

5. If the hyperlink is not available, the application can be found as follows:

Select 'Diagnosis' session type.

Select the following symptoms: Body - Security and locking - Handles locks and latches.

Select the 'Extras' tab.

Run 'Configure existing module - Keyless vehicle module'.

Continue to Step 8.

For:

L405 VIN 212942 to 223058

L494 VIN 516684 to 524055

L494 VIN 612444 to 620148

Or vehicles that have had previous KVM replacement

6. Install the new Keyless Vehicle Module (KVM) (see TOPIx Workshop Manual, section 419-10).

7. If the hyperlink is not available, the application can be found as

follows:

Select 'Service Functions' session type.

Run: Configure new modules - Keyless vehicle module.

- 8.** Follow all on-screen instructions to complete this task. When the task is completed, exit the current session.
- 9.** If required, reset the vehicle to 'Transportation mode'.
- 10.** Disconnect the JLR approved battery support unit.
- 11.** If required, install the transit relay.

Q584NAS1

TECHNICAL BULLETIN

07 APR 2016

© Jaguar Land Rover North America, LLC

NOTE: The information in Technical Bulletins is intended for use by trained, professional Technicians with the knowledge, tools, and equipment required to do the job properly and safely. It informs these Technicians of conditions that may occur on some vehicles, or provides information that could assist in proper vehicle service. The procedures should not be performed by 'do-it-yourselfers'. If you are not a Retailer, do not assume that a condition described affects your vehicle. Contact an authorized Land Rover service facility to determine whether this bulletin applies to a specific vehicle.

INFORMATION

SECTION:

419-10

SUBJECT/CONCERN:

Service Action: Remote Function Actuator Not Communicating

AFFECTED VEHICLE RANGE:

MODEL:	MODEL YEAR:	VIN:	ASSEMBLY PLANT:
Range Rover Evoque (LV)	2016	077912-120509	Halewood
Range Rover Sport (LW)	2016	542167-570313	Solihull
Range Rover Sport (LW)	2016	630155-643876	Solihull

MODEL:	MODEL YEAR:	VIN:	ASSEMBLY PLANT:
Range Rover (LG)	2016	243379-272740	Solihull

MARKETS:

NAS

CONDITION SUMMARY:

SITUATION:

An issue has been identified on a limited number of vehicles within the Affected Vehicle Range where the Passive Entry/Passive Unlock and Keyless Start features may be inoperative and the engine will not start normally. When this occurs, the Emergency Key Blade is needed to unlock the driver's door to enter the vehicle and the Smart key must then be held next to the Immobilizer Antenna Unit (IAU) and the engine START/STOP switch must be pressed to start the engine.

ACTION:

Retailers are required to **HOLD** only affected new vehicles that are within your control and refrain from releasing the vehicles for **new vehicle sale** pending completion of the Service Instruction detailed in this Technical Bulletin. Unsold vehicles should have this performed as part of the Pre-Delivery Inspection (PDI) process but **must** have it completed prior to vehicle handover to the customer.

Affected vehicles already in the hands of customers should be updated at the next available opportunity.

PARTS:

No parts required.

SPECIAL TOOLS:

NOTE:

this Active Bulletin will display a functional programming shortcut if accessed within a diagnostic session using the Jaguar Land Rover-approved diagnostic tool with latest DVD and Calibration File.

Jaguar Land Rover-approved diagnostic tool with latest DVD and Calibration File

Jaguar Land Rover-approved Midtronics Battery Power Supply

WARRANTY:

NOTE:

check DDW to ensure that a vehicle is affected by this program prior to undertaking any rework action.

At the time of confirming a booking for vehicle repair, ensure that all outstanding Recalls and Service Actions are identified to ensure the correct parts are available and adequate workshop time is allocated for repairs to be completed at one visit.

Warranty claims must be submitted quoting Program Code **Q584** together with the relevant Option Code from the table. SRO and parts information is included for information only. The Option Code(s) that allows for the drive in / drive out allowance can only be claimed if the vehicle is brought back into the workshop for this action alone to be undertaken.

This program is valid for a limited time only. Warranty claims with a repair date prior to the **31 March 2018** closure date must be submitted or payment within 30 calendar days of completion of the repair.

Repair procedures are under constant review and therefore times / prices are subject to change; those quoted here must be taken as guidance only. Refer to TOPIx to obtain the latest repair time.

NOTE:

the Remote Function Actuator (RFA) may also be referred to as Keyless Vehicle Module (KVM).

PROGRAM CODE	OPTION CODE	DESCRIPTION	SRO	TIME (HOURS)	PARTS/SUNDRY CODE	QTY./VALUE
--------------	-------------	-------------	-----	--------------	-------------------	------------

Q584	B	Configure the Remote Function Actuator (RFA)	86.90.84	0.20	-	-
Q584	C	Configure the Remote Function Actuator (RFA) Drive in/drive out	86.90.84 02.02.02	0.20 0.20	- -	- -

Normal Warranty policies and procedures apply.

SERVICE INSTRUCTION:

The Smart key contains an emergency key blade to be used in the event of failure of the Smart key or the vehicle battery to unlock the vehicle. The driver's door exterior handle contains a concealed mechanical key barrel which, with the emergency key blade, is used to unlock the driver's door and access the vehicle. This will not disable the perimeter or interior alarm systems which will be activated when the door is opened. To cancel the alarm, the Smart key must be held next to the Immobilizer Antenna Unit (IAU) and the engine START/STOP switch must be pressed (see TOPIx Workshop Manual section 501-14: Handles, Locks, Latches and Entry Systems > Description and Operation).

CAUTIONS:

- a Jaguar Land Rover-approved Midtronics battery power supply must be connected to the vehicle battery during diagnosis/module programming.
- ensure all ignition ON / OFF requests are carried out; failure to perform these steps may cause damage to control modules in the vehicle.

NOTES:

- the Jaguar Land Rover-approved diagnostic tool must be loaded with DVD145.00 v.235 or later.
- if the Remote Function Actuator (RFA) is offline at the start of the session, perform a hard reset or momentarily pull the power fuse for the RFA and re-insert. If the RFA is now responding on the network, continue with this Service Instruction. If the RFA is not responding on the network, diagnose as necessary and then continue with this Service Instruction.

1 Connect the Jaguar Land Rover-approved Midtronics battery power supply to the vehicle battery.

The Remote Function Actuator (RFA) may also be referred to as Keyless Vehicle Module (KVM).

2 Turn ignition ON (engine not running).

3 Connect the Jaguar Land Rover-approved diagnostic tool to the vehicle and begin a new session.

4 Follow the on-screen prompts, allowing the diagnostic tool to read the VIN and identify the vehicle and initiating the data collect sequence.

5 Select **Diagnosis** from the Session Type screen.

6 Select the **Selected Symptoms** tab, and then select the following:

- **Body - Security and locking - Handles locks and latches**

7 Read and close any publication from the list of recommended candidates to expose the **Extras** tab.

8 Select the **Extras** tab.

9 From the Recommendations tab, select **Run** to perform the **Configure existing module - Keyless vehicle module** option.

10 Follow all on-screen instructions to complete this task, ensuring all DTCs are cleared.

11 Exit the current session.

12

Disconnect the diagnostic tool and battery power supply from the vehicle.



ABOVE & BEYOND

OWNER-NOTIFIED SERVICE ACTION Q584: REMOTE FUNCTION ACTUATOR NOT COMMUNICATING

SERVICE BULLETIN

07-APR-16 | No.: SGI16-20 | SEC.: GENERAL INFORMATION | MKT.: CAN / USA

DESCRIPTION

A potential issue has been identified on a limited number of vehicles listed within the Affected Vehicle Range where the Passive Entry/Passive Unlock and Keyless Start features may be inoperative and the engine will not start normally. When this occurs, the Emergency Key Blade is needed to unlock the driver's door to enter the vehicle and the Smart key must then be held next to the Immobilizer Antenna Unit (IAU) and the engine START/STOP switch must be pressed to start the engine.

AFFECTED VEHICLE RANGE

The VIN ranges of affected vehicles are:

Range Rover Evoque (L538)

Model Year 2016
VIN: GH077912-GH120509

Range Rover Sport (L494)

Model Year 2016
VIN: GA542167-GA570313; GA630155-GA643876

Range Rover (L405)

Model Year 2016
VIN: GA243379-GA272740

Go to InfoTrail for a [list of affected unsold vehicles](#) (as of 7 April 2016).

OWNER NOTIFICATION

Mailing of owner notification letters will occur on or before the week of 25 April 2016.

ACTION TO BE TAKEN

Check DDW to ensure that the vehicle is affected by this program (**Q584**) prior to undertaking any rework action. Retailers are required to **HOLD** only affected **new vehicles** that are within your control and refrain from releasing the vehicles for new vehicle sale pending completion of the rework action. Refer to Technical Bulletin Q584NAS, *Service Action: Remote Function Actuator Not Communicating*, for detailed repair instructions.

PARTS

No parts required.

TOOLS

Refer to the Technical Bulletin noted above for any required tools.

WARRANTY

NOTE: check DDW to ensure that a vehicle is affected by this program prior to undertaking any rework action.

Jaguar Land Rover North America, LLC
ATTN: Customer Relationship Centre
555 MacArthur Boulevard
Mahwah, NJ 07430

Thank you again for selecting Land Rover; your ownership experience is very important to us. We recognize this service visit may be an inconvenience to you. Land Rover, in cooperation with your authorized Land Rover retailer, will strive to minimize any inconvenience to you caused by this program.

Sincerely,

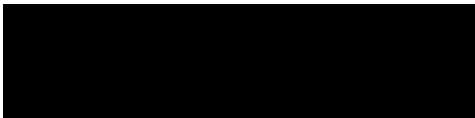

Peter Pochapsky
Customer Relationship Centre Manager

SERVICE ACTION Q584: SAMPLE OWNER LETTER – CANADA

April 2016

RE: Service Action: Remote Function Actuator Not Communicating

**Vehicles Affected: Range Rover Evoque, Range Rover Sport, Range Rover
Model Year: 2016**

Dear Land Rover Owner,

Jaguar Land Rover Canada ULC is conducting a no-charge Customer Satisfaction program (program code Q584) for owners of 2016 model year Range Rover Evoque, Range Rover Sport, and Range Rover models.

Your vehicle is included in this program.

What is the concern?

A Remote Function Actuator software issue may result in the Passive Entry/Passive Unlock or Keyless Start feature becoming inoperative.

If either of these concerns is present, the Emergency Key Blade would be needed to unlock the driver's door or the Smart key must be held next to the Immobilizer Antenna Unit (IAU) and the engine START/STOP switch must be pressed to start the engine.

What will Land Rover and your Land Rover retailer do?

An authorized Land Rover retailer will update the Remote Function Actuator software to the latest level.

What should you do?

Contact your preferred Land Rover retailer and provide the retailer with your Vehicle Identification Number (VIN) and request a service date to complete the work required under Program Code Q584.

How long will it take?

The work will be carried out as quickly and efficiently as possible in order to minimize inconvenience to customers and is expected to take approximately 30 minutes, although your retailer may need your vehicle for a longer time due to service scheduling requirements and vehicle conditioning.

Attention Leasing Agencies: please forward this notification to the lessee within ten (10) days.

Moved or no longer own a Land Rover?

If you are no longer the owner of this vehicle, Land Rover would appreciate the name and address of the new owner (if known); please fill out and return the enclosed return postage-paid card.

What should you do if you have further questions?

If you have any questions or concerns, please contact the Service Manager at your authorized Land Rover retailer for assistance. If you have any queries or concerns that your local retailer cannot address, please contact the Land Rover Customer Relationship Centre at 800-346-3493, Option 9, and one of our representatives will be happy to assist you.

You may also contact Land Rover by e-mail. Visit the web site <http://www.landrover.ca> and send an email from the 'Contact Us' section.

Should you have the need to contact Land Rover by mail, please use the following address:

Jaguar Land Rover Canada ULC
ATTN: Customer Relationship Centre

75 Courtneypark Drive West, Unit 3
Mississauga, ON L5W 0E3

Thank you again for selecting Land Rover; your ownership experience is very important to us. We recognize this service visit may be an inconvenience to you. Land Rover, in cooperation with your authorized Land Rover retailer, will strive to minimize any inconvenience to you caused by this program.

Sincerely,



Peter Pochapsky
Customer Relationship Centre Manager

Sample

At the time of confirming a booking for vehicle repair, ensure that all outstanding Service Actions are identified to ensure the correct parts are available and adequate workshop time is allocated for repairs to be completed at one visit.

Warranty claims must be submitted quoting Program Code '**Q584**' together with the relevant Option Code from the table. SRO and parts information is included for information only. The Option Code(s) that allows for the drive in / drive out allowance may only be claimed if the vehicle is brought into the workshop for this action alone to be undertaken. Repair procedures are under constant review and therefore times / prices are subject to change; those quoted here must be taken as guidance only. Refer to TOPIx to obtain the latest repair time.

This program is valid for a limited time only. Warranty claims with a repair date prior to the **31 March 2018** closure date must be submitted for payment within 30 calendar days of completion of the repair.

NOTE: the Remote Function Actuator (RFA) may also be referred to as Keyless Vehicle Module (KVM).

PROGRAM CODE	OPTION CODE	DESCRIPTION	SRO	TIME (HOURS)	PART No. / SUNDRY CODE	QTY. / VALUE
Q584	B	Configure the Remote Function Actuator (RFA)	86.90.84	0.20	-	-
Q584	C	Configure the Remote Function Actuator (RFA)	86.90.84	0.20	-	-
		Drive in/drive out	02.02.02	0.20	-	-

Normal Warranty policies and procedures apply.

Contact information

Lourdes Clemente
Field Actions Administrator
201.818.8015
lclemen4@jaguarlandrover.com

SERVICE ACTION Q584: SAMPLE OWNER LETTER – USA

April 2016

RE: Service Action: Remote Function Actuator Not Communicating

**Vehicles Affected: Range Rover Evoque, Range Rover Sport, Range Rover
Model Year: 2016**

Dear Land Rover Owner,

Jaguar Land Rover North America, LLC is conducting a no-charge Customer Satisfaction program (program code Q584) for owners of 2016 model year Range Rover Evoque, Range Rover Sport, and Range Rover models.

Your vehicle is included in this program.

What is the concern?

A Remote Function Actuator software issue may result in the Passive Entry/Passive Unlock or Keyless Start feature becoming inoperative.

If either of these concerns is present, the Emergency Key Blade would be needed to unlock the driver's door or the Smart key must be held next to the Immobilizer Antenna Unit (IAU) and the engine START/STOP switch must be pressed to start the engine.

What will Land Rover and your Land Rover retailer do?

An authorized Land Rover retailer will update the Remote Function Actuator software to the latest level.

What should you do?

Contact your preferred Land Rover retailer and provide the retailer with your Vehicle Identification Number (VIN) and request a service date to complete the work required under Program Code Q584.

How long will it take?

The work will be carried out as quickly and efficiently as possible in order to minimize inconvenience to customers and is expected to take approximately 30 minutes, although your retailer may need your vehicle for a longer time due to service scheduling requirements and vehicle conditioning.

Attention Leasing Agencies: please forward this notification to the lessee within ten (10) days.

Moved or no longer own a Land Rover?

If you are no longer the owner of this vehicle, Land Rover would appreciate the name and address of the new owner (if known); please fill out and return the enclosed return postage-paid card.

What should you do if you have further questions?

If you have any questions or concerns, please contact the Service Manager at your authorized Land Rover retailer for assistance. If you have any queries or concerns that your local Retailer cannot address, please contact the Land Rover Customer Relationship Centre at 800-637-6837, Option 9, and one of our representatives will be happy to assist you.

You can also contact Land Rover by email. Visit the website <http://www.landroverusa.com>, select 'Contact Us' and send an email from the 'Email Land Rover' link.

Should you have the need to contact Land Rover by mail, please use the following address:



ABOVE & BEYOND

**SERVICE
BULLETIN**

NOTIFICATION OF SAFETY RECALL P068 (NHTSA# 15V-385): VEHICLE DOOR MAY NOT LATCH - UPDATED

15-JUL-15	NO.: SRE15-12 [issue 2]	SECTION: RECALL	MARKET: USA
-----------	----------------------------	-----------------	-------------

Jaguar Land Rover North America, LLC has informed the National Highway Traffic Safety Administration (NHTSA) of its intent to perform a voluntary Safety Recall involving 2014-2016 model year Land Rover Range Rover Sport and 2013-2016 model year Range Rover vehicles imported into the United States market. Information relating to the proposed Recall will be posted on the NHTSA website.

United States Federal regulations require that retailers must be advised of this Recall notification within three working days after government notification.

United States Federal law requires retailers to complete any outstanding safety Recall service before a new vehicle is delivered to the buyer or lessee. Violation of this requirement by a retailer could result in a civil penalty of up to \$7,000.00 per vehicle.

This Recall Service Bulletin serves as notification to all Land Rover retailers in the United States that any affected new vehicles may not be sold and delivered for customer use until the Recall repair is completed.

AFFECTED VEHICLES

A total of 65,352 vehicles are affected. The VIN ranges of affected vehicles are:

- Range Rover Sport (L494) SALWR2WFOEA000002-SALWR2KF6GA619695
- Range Rover (L405) SALGS2DF4DA000157-SALGS3KFXGA222280

DESCRIPTION OF DEFECT

A concern has been identified on 2014-2016 model year Range Rover Sport (L494) and 2013-2016 model year Range Rover (L405) vehicles where customers have reported the door is unlatched when in the closed position and no indication provided of an unlatched condition. Some customers have reported that one door has opened while the vehicle was in motion.

EFFECT ON VEHICLE OPERATION

Vehicle doors not latched in either the primary or secondary state may, during driving, open. This can increase the risk of a vehicle crash or compromise the safety of vehicle occupants.

SERVICE PROGRAM / REWORK ACTION

Owners will be instructed to take their vehicle to an approved Land Rover retailer who will download the latest software. There will be no charge to owners for this repair.

Customers who have paid for a repair of this defect will be eligible for reimbursement subject to the Jaguar Land Rover reimbursement plan subject to meeting the current terms and conditions.

Further communication will be published once the necessary rework action required for affected vehicles is finalized.

Please find the Technical Q & A attached to assist with any customer inquiries.

OWNER NOTIFICATION

Mailing of owner notification letters will occur on or before 7 August 2015.

ACTION TO BE TAKEN

Check DDW to ensure that a vehicle is affected by this program **(P068)** prior to undertaking any rework action.

Retailers are required to HOLD only affected new vehicles that are within your control and refrain from releasing the vehicles for new vehicle sale pending completion of the rework action.

Sold vehicles will be subject to the standard Recall notification and Recall bulletin process detailing the action required for vehicles in the hands of owners.

Retailers are advised that the use of affected vehicles as Sales Demonstrator or Service Loaner vehicles may be considered a violation of Federal legislation. Jaguar Land Rover North America, LLC recommends against using affected vehicles for demonstrator or loaner purposes. Please consult your own legal counsel if you have questions in this regard.

Thank you for your cooperation in this matter. Jaguar Land Rover North America apologizes for any inconvenience this may cause.

SAFETY RECALL P068: TECHNICAL Q & A

Main Message: A concern has been identified where customers have reported the door is unlatched when in the closed position and no indication provided of an unlatched condition. Some customers have reported that one door has opened while the vehicle was in motion. Vehicle doors not latched in either the primary or secondary state may, during driving, open. This can increase the risk of a vehicle crash or compromise the safety of vehicle occupants.

Q1 Who do I contact if a member of the press contacts me about this recall?

A Please ensure that any Press enquiries are referred to the Jaguar Land Rover Corporate Affairs office.

Q2 Why is Jaguar Land Rover Limited recalling certain Land Rover vehicles?

A Customers have reported doors opening while the vehicle is in motion and no warning of an unlatched condition on the instrument cluster. This is considered to be a safety issue and a recall is required to remedy the defect.

Q3 Can you tell me more about what is wrong with the vehicles?

A In late January 2015 an electrical system specification difference was identified where a short circuit was applied to the keyless vehicle release motor directly after energizing for a keyless vehicle passive entry actuation whereas the latch supplier specification stated a preference for open circuit. This short circuit effectively turns the motor into a brake, slowing or in some cases stopping the keyless vehicle lever from returning to its home position. If the keyless vehicle lever is held away from its home position then the pawl is constantly in a state of clearance to the claw - the claw is free to rotate, and release. This means that during a standard door closure operation the latch appears to take the striker and the door can be closed with the side of the vehicle but the door is not securely retained by the latch.

Q4 How would the customer become aware of potentially having this concern?

A It is possible that in the condition described, the door will not close and latch bouncing back so illuminating the door ajar switch, but there are cases where the door can appear closed although not latched at which point there is little obvious indication of the issue.

Q5 Does this concern affect vehicle safety?

A Yes. Jaguar Land Rover has determined that this condition does pose a safety risk which is why a safety recall is being conducted.

Q6 Has Jaguar Land Rover Limited received many complaints?

A Jaguar Land Rover has received a number of customer complaints relating to this issue.

Q7 Have there been any accidents or injuries or fires?

A Jaguar Land Rover is unaware of any accident, injuries or fires which have been attributed to this issue.

Q8 How was the condition discovered?

A Jaguar Land Rover was alerted to this concern through quality data reporting systems.

Q9 How long has Jaguar Land Rover known about this problem?

A Jaguar Land Rover began investigating the issue in October 2014.

Q10 Is the defect leading you to any concerns regarding the reliability of a system, which is supposed to be designed and engineered for the passengers' safety? What type of measures are you planning to take?

A We have no concerns with the overall reliability of the vehicle. Jaguar Land Rover carefully monitors field data to ensure that any matters relating to safety and compliance are rigorously investigated.

Q11 What has Jaguar Land Rover done in production?

A Modifications have been made to remove the sensitivity of the door latch and associated mechanisms to the condition mentioned above.

Q12 What is the repair for this issue?

A Jaguar Land Rover will mail affected owners asking them to bring their vehicle to a Jaguar retailers of their choice to download the latest software making the motor open circuit in line with the latch manufacturers specification preference.

Q13 Which vehicles are affected by this recall?

A Certain 2013 to 2016 Model Year Land Rover Range Rover vehicles and certain 2014 to 2016 Model Year Land Rover Range Rover Sport vehicles built at the Solihull (UK) Assembly Plant from May 9, 2012 to March 12, 2015.

Q14 Are other Jaguar Land Rover models affected by these actions?

A No other models are known to be affected by this condition, other than those listed on this document.

Q15 Are parts available to rework vehicles?

A Vehicle software will be available for the rework when the repair instructions are issued.

Q16 How much will this recall cost Jaguar Land Rover?

A Cost was not a factor in deciding to recall these vehicles.

Q17 How do I know if my vehicle is affected?

A All owners of potentially affected vehicles will shortly receive a letter inviting them to contact a Land Rover authorized repairer for the work to be carried out.

Q18 How long does it take for the vehicle to be inspected and repaired?

A The work will be carried out as quickly and efficiently as possible in order to minimize inconvenience to customers and is expected to take 30 minutes to complete. Naturally, due to dealer schedules, vehicles may be required for longer.

Q19 Can I continue to drive my vehicle safely until it has been recalled?

A Customers are advised to contact a Land Rover authorized repairer should they have any concerns regarding their vehicles. Until such time as your vehicle is repaired, Jaguar Land Rover strongly recommend that all vehicle occupants are secured using the vehicle seat belts and that the driver observe any door open warnings displayed in the instrument pack.

Note: Please ensure that any Press enquiries are referred to the Jaguar Land Rover Corporate Affairs office.



ABOVE & BEYOND

NOTIFICATION OF SAFETY RECALL P068: VEHICLE DOOR MAY NOT LATCH

SERVICE BULLETIN

16-JUN-15

NO.: SRE15-12

SECTION: RECALL

MARKET: USA

Jaguar Land Rover North America, LLC has informed the National Highway Traffic Safety Administration (NHTSA) of its intent to perform a voluntary Safety Recall involving 2014-2016 model year Land Rover Range Rover Sport and 2013-2016 model year Range Rover vehicles imported into the United States market. Information relating to the proposed Recall will be posted on the NHTSA website.

United States Federal regulations require that retailers must be advised of this Recall notification within three working days after government notification.

United States Federal law requires retailers to complete any outstanding safety Recall service before a new vehicle is delivered to the buyer or lessee. Violation of this requirement by a retailer could result in a civil penalty of up to \$7,000.00 per vehicle.

This Recall Service Bulletin serves as notification to all Land Rover retailers in the United States that any affected new vehicles may not be sold and delivered for customer use until the Recall repair is completed.

AFFECTED VEHICLES

A total of 65,352 vehicles are affected. The VIN ranges of affected vehicles are:

- Range Rover Sport (L494) SALWR2WFO**EA000002**-SALWR2KF6**GA619695**
- Range Rover (L405) SALGS2DF4**DA000157**-SALGS3KFX**GA222280**

DESCRIPTION OF DEFECT

A concern has been identified on 2014-2016 model year Range Rover Sport (L494) and 2013-2016 model year Range Rover (L405) vehicles where customers have reported the door is unlatched when in the closed position and no indication provided of an unlatched condition. Some customers have reported that one door has opened while the vehicle was in motion.

EFFECT ON VEHICLE OPERATION

Vehicle doors not latched in either the primary or secondary state may, during driving, open. This can increase the risk of a vehicle crash or compromise the safety of vehicle occupants.

SERVICE PROGRAM / REWORK ACTION

Owners will be instructed to take their vehicle to an approved Land Rover retailer who will download the latest software. There will be no charge to owners for this repair.

Customers who have paid for a repair of this defect will be eligible for reimbursement subject to the Jaguar Land Rover reimbursement plan subject to meeting the current terms and conditions.

Further communication will be published once the necessary rework action required for affected vehicles is finalized.

OWNER NOTIFICATION

Mailing of owner notification letters will occur on or before 7 August 2015.

ACTION TO BE TAKEN

Check DDW to ensure that a vehicle is affected by this program (P068) prior to undertaking any rework action.

Retailers are required to **HOLD** only affected new vehicles that are within your control and refrain from releasing the vehicles for **new vehicle sale** pending completion of the rework action.

Sold vehicles will be subject to the standard Recall notification and Recall bulletin process detailing the action required for vehicles in the hands of owners.

Retailers are advised that the use of affected vehicles as Sales Demonstrator or Service Loaner vehicles may be considered a violation of Federal legislation. Jaguar Land Rover North America, LLC recommends against using affected vehicles for demonstrator or loaner purposes. Please consult your own legal counsel if you have questions in this regard.

Thank you for your cooperation in this matter. Jaguar Land Rover North America apologizes for any inconvenience this may cause.



ABOVE & BEYOND

SAFETY RECALL P068 (NHTSA# 15V-385): VEHICLE DOOR WILL NOT LATCH – UPDATE

SERVICE BULLETIN

31-JUL-15

NO.: SRE15-14
(issue 2)

SECTION: RECALL

MARKET: USA

CHANGES ARE HIGHLIGHTED IN GRAY

Jaguar Land Rover North America, LLC has informed the National Highway Traffic Safety Administration (NHTSA) of its intent to perform a voluntary Safety Recall involving 2014-2016 model year Land Rover Range Rover Sport and 2013-2016 model year Range Rover vehicles imported into the United States market. Information relating to the proposed Recall will be posted on the NHTSA website.

United States Federal regulations require that retailers must be advised of this Recall notification within three working days after government notification.

United States Federal law requires retailers to complete any outstanding safety Recall service before a new vehicle is delivered to the buyer or lessee. Violation of this requirement by a retailer could result in a civil penalty of up to \$7,000.00 per vehicle.

This Recall Service Bulletin serves as notification to all Land Rover retailers in the United States that any affected new vehicles may not be sold and delivered for customer use until the Recall repair is completed.

THIS BULLETIN UPDATES SRE15-12

AFFECTED VEHICLES

A total of 65,352 vehicles are affected. The model year and VIN ranges of affected vehicles are:

- Range Rover Sport (L494) 2014-2015 EA000002-FA524037
2015 FA600188-FA620146
2016 GA519971-GA523677
2016 GA617562-GA619965
- Range Rover (L405) 2013-2015 DA000157-FA223054
2016 GA216967-GA222280

DESCRIPTION OF DEFECT

A concern has been identified where customers have reported the door is unlatched when in the closed position and no indication provided of an unlatched condition. Some customers have reported that one door has opened while the vehicle was in motion.

EFFECT ON VEHICLE OPERATION

Vehicle doors not latched in either the primary or secondary state may, during driving, open. This can increase the risk of a vehicle crash or compromise the safety of vehicle occupants.

SERVICE PROGRAM / REWORK ACTION

Owners will be instructed to take their vehicle to an approved Land Rover retailer who will download the latest software. There will be no charge to owners for this repair.

Refer to Technical Bulletin P068NAS, *Safety Recall: Vehicle Door Will Not Latch*, for complete repair details.

OWNER NOTIFICATION

Mailing of owner notification letters will occur on or before 7 August 2015.

ACTION TO BE TAKEN

Check DDW to ensure that the vehicle is affected by this program (**P068**) prior to undertaking any rework action.

Retailers are required to **HOLD** only affected new vehicles that are within your control and refrain from releasing the vehicles for new vehicle sale pending completion of the rework action.

Sold vehicles will be subject to the standard Recall notification and Recall bulletin process detailing the action required for vehicles in the hands of owners.

Retailers are advised that the use of affected vehicles as Sales Demonstrator or Service Loaner vehicles may be considered a violation of Federal legislation. Jaguar Land Rover North America, LLC recommends against using affected vehicles for demonstrator or loaner purposes. Please consult your own legal counsel if you have questions in this regard.

Thank you for your cooperation in this matter. Jaguar Land Rover North America apologizes for any inconvenience this may cause.

PARTS

No parts required.

TOOLS

Refer to the Technical Bulletin noted above for any required tools.

WARRANTY

NOTE: check DDW to ensure that a vehicle is affected by this program prior to undertaking any rework action.

At the time of confirming a booking for vehicle repair, ensure that all outstanding Service Actions are identified to ensure the correct parts are available and adequate workshop time is allocated for repairs to be completed at one visit.

Warranty claims must be submitted quoting Program Code '**P068**' together with the relevant Option Code from the table. SRO information is included for information only. The Option Code(s) that allows for the drive in / drive out allowance may only be claimed if the vehicle is brought into the workshop for this action alone to be undertaken.

Repair procedures are under constant review and therefore times / prices are subject to change; those quoted here must be taken as guidance only. Refer to TOPIx to obtain the latest repair time.

Warranty claims must be submitted for payment within 30 calendar days of completion of the repair.

PROGRAM CODE	OPTION CODE	DESCRIPTION	SRO	TIME (HOURS)	PART No. / SUNDRY CODE	QTY. / VALUE
P068	B	Configure existing keyless vehicle module	86.90.84	0.20	-	-
P068	C	Configure existing keyless vehicle module	86.90.84	0.20	-	-
		Drive in/Drive out	02.02.02	0.20	-	-

Normal Warranty policies and procedures apply.

CUSTOMER RE-IMBURSEMENT FOR PREVIOUS REPAIRS

If a customer has indicated that they have already paid for a door not latching issue as a normal retail repair (vehicle outside normal warranty period), a copy of the repair invoice must be produced as proof of the repair. The retailer must directly reimburse the customer and a claim for recovery of this cost should be made using the related damage procedure.

Supplementary claims for related damages can only be made once this Recall claim has been paid and accepted. Only repairs performed using approved Land Rover parts are eligible for reimbursement.

Claims should be submitted quoting program code 'P068' and by clicking the 'Related Damage' radio button on the claim submission screen.

The warranty claim should be submitted using Option Code 'X' as detailed below and entering the cost to be reimbursed against the sundry code of 'ZZZ001'. All costs should be entered in local currency.

PROGRAM CODE	OPTION CODE	DESCRIPTION	TIME (HOURS)	SUNDRY ITEM CODE	MISCELLANEOUS EXPENSE (\$)
P068	X	Re-imbusement to owner	N/A	ZZZ001	Retailer Entered Value

A copy of the invoice must be appended to the repair order for Warranty Audit purposes and Warranty Specialist review. A brief comment should be entered in the 'Technician Comments' field on the claim to itemize and explain the charges.

Only vehicles eligible for Safety Recall P068 are included in this process. Only one claim per vehicle for related damages will be accepted.

SAFETY RECALL P068: SAMPLE OWNER LETTER

IMPORTANT SAFETY RECALL

This notice applies to your vehicle SALXXXXXXXXXXXXX

August 2015

RE: Safety Recall P068 – Vehicle Door Will Not Latch

Vehicle Affected: Range Rover, Range Rover Sport

Model Year: 2013–2016

National Highway Traffic Safety Administration Recall Number: 15V-385

Dear Land Rover Owner,

This notice is sent to you in accordance with the requirements of the National Traffic and Motor Vehicle Safety Act. Land Rover has decided that a defect which relates to motor vehicle safety exists in certain 2013-2016 model year Land Rover Range Rover and Range Rover Sport vehicles. Your vehicle is included in this Recall action.

What is the concern?

A concern has been identified where customers have reported the inability to secure the door in the closed position either on the primary or secondary latch. Some customers have reported that one of the vehicle doors has opened while the vehicle was in motion. Vehicle doors not securely latched in the closed condition may, during driving, open. This can increase the risk of a vehicle crash or compromise the safety of vehicle occupants.

What Jaguar Land Rover Limited and your Land Rover retailer will do?

Land Rover is carrying out a recall of the vehicles mentioned above. An authorized Land Rover retailer will download the latest software. There will be no charge for this repair.

What should you do?

Contact your preferred Land Rover retailer and provide the retailer with your Vehicle Identification Number (VIN) and request a service date to complete the work required under Program Code P068. Until such time as your vehicle is repaired, Jaguar Land Rover strongly recommend that all vehicle occupants are secured using the vehicle seat belts and that the driver observe any door open warnings displayed in the instrument pack.

How long will it take?

The work will be carried out as quickly and efficiently as possible in order to minimize inconvenience to customers and is expected to take approximately 30 minutes, although your retailer may need your vehicle for a longer time due to service scheduling requirements and vehicle conditioning.

What if I have previously paid for a door not latching issue for this concern?

If you have already paid for a door not latching issue before the date of this letter, Land Rover is offering a refund. In order to qualify for a refund, please provide your authorized Land Rover Retailer with the original paid receipt.

To avoid delays, please do not send the receipt to Land Rover North America.

Attention Leasing Agencies: Federal regulations require that you forward this recall notification to the lessee within TEN (10) days.

Moved or no longer own a Land Rover?

If you are no longer the owner of this vehicle, Land Rover would appreciate the name and address of the new owner (if known); please fill out and return the enclosed return postage-paid card.

What should you do if you have further questions?

If you have any questions or concerns, please contact the Service Manager at your authorized Land Rover retailer for assistance. If you have any queries or concerns that your local Retailer cannot address, please contact the Land Rover Customer Relationship Centre at 1-800-637-6837, Option 9, and one of our representatives will be happy to assist you.

You can also contact Land Rover by email. Visit the website <http://www.landroverusa.com>, select 'Contact Us' and send an email from the 'Email Land Rover' link.

Should you have the need to contact Land Rover by mail, please use the following address:

Jaguar Land Rover North America, LLC
ATTN: Customer Relationship Centre
555 MacArthur Boulevard
Mahwah, NJ 07430

If you are having difficulty getting your vehicle repaired in a reasonable time or without charge, you may write to:

Administrator, National Highway Traffic Safety Administration
1200 New Jersey Avenue, SE
Washington, D.C. 20510

Or you may call the toll-free Vehicle Safety Hotline at 1-888-327-4236 (TTY: 1-800-424-9153), or log on to <http://www.safercar.gov> to submit a complaint electronically.

Thank you again for selecting Land Rover; your ownership experience is very important to us. We recognize this service visit may be an inconvenience to you. Land Rover, in cooperation with your authorized Land Rover retailer, will strive to minimize any inconvenience to you caused by this program.

Sincerely,

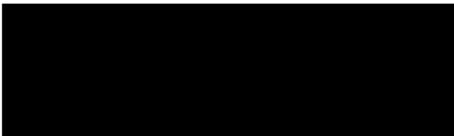

Peter Pochajsky
Customer Relationship Centre Manager

SAFETY RECALL P068: TECHNICAL Q & A

Main Message: a concern has been identified where customers have reported the door is unlatched when in the closed position and no indication provided of an unlatched condition. Some customers have reported that one door has opened while the vehicle was in motion. Vehicle doors not latched in either the primary or secondary state may, during driving, open. This can increase the risk of a vehicle crash or compromise the safety of vehicle occupants.

Q1 Who do I contact if a member of the press contacts me about this recall?

A Please ensure that any Press enquiries are referred to the Jaguar Land Rover Corporate Affairs office.

Q2 Why is Jaguar Land Rover Limited recalling certain Land Rover vehicles?

A Customers have reported doors opening while the vehicle is in motion and no warning of an unlatched condition on the instrument cluster. This is considered to be a safety issue and a recall is required to remedy the defect.

Q3 Can you tell me more about what is wrong with the vehicles?

A In late January 2015 an electrical system specification difference was identified where a short circuit was applied to the keyless vehicle release motor directly after energizing for a keyless vehicle passive entry actuation whereas the latch supplier specification stated a preference for open circuit. This short circuit effectively turns the motor into a brake, slowing or in some cases stopping the keyless vehicle lever from returning to its home position. If the keyless vehicle lever is held away from its home position then the pawl is constantly in a state of clearance to the claw - the claw is free to rotate, and release. This means that during a standard door closure operation the latch appears to take the striker and the door can be closed with the side of the vehicle but the door is not securely retained by the latch.

Q4 How would the customer become aware of potentially having this concern?

A It is possible that in the condition described, the door will not close and latch bouncing back so illuminating the door ajar switch, but there are cases where the door can appear closed although not latched at which point there is little obvious indication of the issue.

Q5 Does this concern affect vehicle safety?

A Yes. Jaguar Land Rover has determined that this condition does pose a safety risk which is why a safety recall is being conducted.

Q6 Has Jaguar Land Rover Limited received many complaints?

A Jaguar Land Rover has received a number of customer complaints relating to this issue.

Q7 Have there been any accidents or injuries or fires?

A Jaguar Land Rover is unaware of any accident, injuries or fires which have been attributed to this issue.

Q8 How was the condition discovered?

A Jaguar Land Rover was alerted to this concern through quality data reporting systems.

Q9 How long has Jaguar Land Rover known about this problem?

A Jaguar Land Rover began investigating the in October 2014.

Q10 Is the defect leading you to any concerns regarding the reliability of a system, which is supposed to be designed and engineered for the passengers' safety? What type of measures are you planning to take?

A We have no concerns with the overall reliability of the vehicle. Jaguar Land Rover carefully monitors field data to ensure that any matters relating to safety and compliance are rigorously investigated.

Q11 What has Jaguar Land Rover done in production?

A Modifications have been made to remove the sensitivity of the door latch and associated mechanisms to the condition mentioned above.

Q12 What is the repair for this issue?

A Jaguar Land Rover will mail affected owners asking them to bring their vehicle to a Land Rover retailer of their choice to download the latest software making the motor open circuit in line with the latch manufacturers specification preference.

Q13 Which vehicles are affected by this recall?

A Certain 2013 to 2016 Model Year Land Rover Range Rover vehicles and certain 2014 to 2016 Model Year Land Rover Range Rover Sport vehicles built at the Solihull (UK) Assembly Plant from May 9, 2012 to March 12, 2015.

Q14 Are other Jaguar Land Rover models affected by these actions?

A No other models are known to be affected by this condition, other than those listed on this document.

Q15 Are parts available to rework vehicles?

A Vehicle software is available for the rework.

Q16 How much will this recall cost Jaguar Land Rover?

A Cost was not a factor in deciding to recall these vehicles.

Q17 How do I know if my vehicle is affected?

A All owners of potentially affected vehicles will shortly receive a letter inviting them to contact a Land Rover authorized repairer for the work to be carried out.

Q18 How long does it take for the vehicle to be inspected and repaired?

A The work will be carried out as quickly and efficiently as possible in order to minimize inconvenience to customers and is expected to take 30 min to complete. Naturally, due to dealer schedules, vehicles may be required for longer.

Q19 Can I continue to drive my vehicle safely until it has been recalled?

A Customers are advised to contact a Land Rover authorized repairer should they have any concerns regarding their vehicles. Until such time as your vehicle is repaired, Jaguar Land Rover strongly recommend that all vehicle occupants are secured using the vehicle seat belts and that the driver observe any door open warnings displayed in the instrument pack.

Note: please ensure that any Press enquiries are referred to the Jaguar Land Rover Corporate Affairs office.



ABOVE & BEYOND

SAFETY RECALL P068 (NHTSA# 15V-385): VEHICLE DOOR MAY NOT LATCH

SERVICE BULLETIN

17-JUL-15 | NO.: SRE15-14 | SECTION: RECALL | MARKET: USA

Jaguar Land Rover North America, LLC has informed the National Highway Traffic Safety Administration (NHTSA) of its intent to perform a voluntary Safety Recall involving 2014-2016 model year Land Rover Range Rover Sport and 2013-2016 model year Range Rover vehicles imported into the United States market. Information relating to the proposed Recall will be posted on the NHTSA website.

United States Federal regulations require that retailers must be advised of this Recall notification within three working days after government notification.

United States Federal law requires retailers to complete any outstanding safety Recall service before a new vehicle is delivered to the buyer or lessee. Violation of this requirement by a retailer could result in a civil penalty of up to \$7,000.00 per vehicle.

This Recall Service Bulletin serves as notification to all Land Rover retailers in the United States that any affected new vehicles may not be sold and delivered for customer use until the Recall repair is completed.

THIS BULLETIN UPDATES SRE15-12

AFFECTED VEHICLES

A total of 65,352 vehicles are affected. The VIN ranges of affected vehicles are:

- Range Rover Sport (L494) **EA000002 - FA524037**
FA6000188 - FA620146
GA519971 - GA619695
- Range Rover (L405) **DA000157 - FA223025**
GA216967 - GA222280

DESCRIPTION OF DEFECT

A concern has been identified where customers have reported the door is unlatched when in the closed position and no indication provided of an unlatched condition. Some customers have reported that one door has opened while the vehicle was in motion.

EFFECT ON VEHICLE OPERATION

Vehicle doors not latched in either the primary or secondary state may, during driving, open. This can increase the risk of a vehicle crash or compromise the safety of vehicle occupants.

SERVICE PROGRAM / REWORK ACTION

Owners will be instructed to take their vehicle to an approved Land Rover retailer who will download the latest software. There will be no charge to owners for this repair.

Refer to Technical Bulletin P068NAS1, *Safety Recall: Vehicle Door May Not Latch*, for complete repair details.

OWNER NOTIFICATION

Mailing of owner notification letters will occur on or before 7 August 2015.

ACTION TO BE TAKEN

Check DDW to ensure that the vehicle is affected by this program (**P068**) prior to undertaking any rework action. Retailers are required to **HOLD** only affected new vehicles that are within your control and refrain from releasing the vehicles for new vehicle sale pending completion of the rework action.

Sold vehicles will be subject to the standard Recall notification and Recall bulletin process detailing the action required for vehicles in the hands of owners.

Retailers are advised that the use of affected vehicles as Sales Demonstrator or Service Loaner vehicles may be considered a violation of Federal legislation. Jaguar Land Rover North America, LLC recommends against using affected vehicles for demonstrator or loaner purposes. Please consult your own legal counsel if you have questions in this regard.

Thank you for your cooperation in this matter. Jaguar Land Rover North America apologizes for any inconvenience this may cause.

PARTS

No parts required

TOOLS

Refer to the Technical Bulletin noted above for any required tools

WARRANTY

NOTE: check DDW to ensure that a vehicle is affected by this program prior to undertaking any rework action.

At the time of confirming a booking for vehicle repair, ensure that all outstanding Service Actions are identified to ensure the correct parts are available and adequate workshop time is allocated for repairs to be completed at one visit.

Warranty claims must be submitted quoting Program Code '**P068**' together with the relevant Option Code from the table. SRO information is included for information only. The Option Code(s) that allows for the drive in / drive out allowance may only be claimed if the vehicle is brought into the workshop for this action alone to be undertaken. Repair procedures are under constant review and therefore times / prices are subject to change; those quoted here must be taken as guidance only. Refer to TOPIx to obtain the latest repair time.

Warranty claims must be submitted for payment within 30 calendar days of completion of the repair.

PROGRAM CODE	OPTION CODE	DESCRIPTION	SRO	TIME (HOURS)
P068	B	Configure existing keyless vehicle module	86.90.84	0.2
P068	C	Configure existing keyless vehicle module Drive in/Drive out	86.90.84 02.02.02	0.2 0.2

Normal Warranty policies and procedures apply

CUSTOMER RE-IMBURSEMENT FOR PREVIOUS REPAIRS

If a customer has indicated that they have already paid for a door not latching issue as a normal retail repair (vehicle outside normal warranty period), a copy of the repair invoice must be produced as proof of the repair. The retailer must directly reimburse the customer and a claim for recovery of this cost should be made using the related damage procedure.

Supplementary claims for related damages can only be made once this Recall claim has been paid and accepted. Only repairs performed using approved Land Rover parts are eligible for reimbursement.

Claims should be submitted quoting program code '**P068**' and by clicking the 'Related Damage' radio button on the claim submission screen.

The warranty claim should be submitted using option code '**X**' as detailed below and entering the cost to be reimbursed against the sundry code of '**ZZZ001**'. All costs should be entered in local currency.

PROGRAM CODE	OPTION CODE	DESCRIPTION	TIME (HOURS)	SUNDRY ITEM CODE	MISCELLANEOUS EXPENSE (\$)
P068	X	Re-imbusement to owner	N/A	ZZZ001	Retailer Entered Value

A copy of the invoice must be appended to the repair order for Warranty Audit purposes and Warranty Specialist review. A brief comment should be entered in the 'Technician Comments' field on the claim to itemize and explain the charges.

Only vehicles eligible for Safety Recall P068 are included in this process. Only one claim per vehicle for related damages will be accepted.

SAFETY RECALL P068: SAMPLE OWNER LETTER

IMPORTANT SAFETY RECALL

This notice applies to your vehicle SALXXXXXXXXXXXXX

August 2015

RE: Safety Recall P068 – Vehicle Door May Not Latch

Vehicle Affected: Range Rover, Range Rover Sport
Model Year: 2013-2016

National Highway Traffic Safety Administration Recall Number: 15V-385

Dear Land Rover Owner,

This notice is sent to you in accordance with the requirements of the National Traffic and Motor Vehicle Safety Act. Land Rover has decided that a defect which relates to motor vehicle safety exists in certain 2013-2016 model year Land Rover Range Rover and Range Rover Sport vehicles. Your vehicle is included in this Recall action.

What is the concern?

A concern has been identified where customers have reported the inability to secure the door in the closed position either on the primary or secondary latch. Some customers have reported that one of the vehicle doors has opened while the vehicle was in motion. Vehicle doors not securely latched in the closed condition may, during driving, open. This can increase the risk of a vehicle crash or compromise the safety of vehicle occupants.

What Jaguar Land Rover Limited and your Land Rover retailer will do?

Land Rover is carrying out a recall of the vehicles mentioned above. An authorized Land Rover retailer will download the latest software. There will be no charge for this repair.

What should you do?

Contact your preferred Land Rover retailer and provide the retailer with your Vehicle Identification Number (VIN) and request a service date to complete the work required under Program Code P068. Until such time as your vehicle is repaired, Jaguar Land Rover strongly recommend that all vehicle occupants are secured using the vehicle seat belts and that the driver observe any door open warnings displayed in the instrument pack.

How long will it take?

The work will be carried out as quickly and efficiently as possible in order to minimize inconvenience to customers and is expected to take approximately 30 minutes, although your retailer may need your vehicle for a longer time due to service scheduling requirements and vehicle conditioning.

What if I have previously paid for a door not latching issue for this concern?

If you have already paid for a door not latching issue before the date of this letter, Land Rover is offering a refund. In order to qualify for a refund, please provide your authorized Land Rover Retailer with the original paid receipt.

To avoid delays, please do not send the receipt to Land Rover North America.

Attention Leasing Agencies: Federal regulations require that you forward this recall notification to the lessee within TEN (10) days.

Moved or no longer own a Land Rover?

If you are no longer the owner of this vehicle, Land Rover would appreciate the name and address of the new owner (if known); please fill out and return the enclosed return postage-paid card.

What should you do if you have further questions?

If you have any questions or concerns, please contact the Service Manager at your authorized Land Rover retailer for assistance. If you have any queries or concerns that your local Retailer cannot address, please contact the Land Rover Customer Relationship Centre at 1-800-637-6837, Option 9, and one of our representatives will be happy to assist you.

You can also contact Land Rover by email. Visit the website <http://www.landroverusa.com>, select 'Contact Us' and send an email from the 'Email Land Rover' link.

Should you have the need to contact Land Rover by mail, please use the following address:

Jaguar Land Rover North America, LLC
ATTN: Customer Relationship Centre
555 MacArthur Boulevard
Mahwah, NJ 07430

If you are having difficulty getting your vehicle repaired in a reasonable time or without charge, you may write to:

Administrator, National Highway Traffic Safety Administration
1200 New Jersey Avenue, SE
Washington, D.C. 20590

Or you may call the toll-free Vehicle Safety Hotline at 1-888-327-4236 (TTY: 1-800-424-9153), or log on to <http://www.safercar.gov> to submit a complaint electronically.

Thank you again for selecting Land Rover; your ownership experience is very important to us. We recognize this service visit may be an inconvenience to you. Land Rover, in cooperation with your authorized Land Rover retailer, will strive to minimize any inconvenience to you caused by this program.

Sincerely,



Peter Pochapsky
Customer Relationship Centre Manager

SAFETY RECALL P068: TECHNICAL Q & A

Main Message: A concern has been identified where customers have reported the door is unlatched when in the closed position and no indication provided of an unlatched condition. Some customers have reported that one door has opened while the vehicle was in motion. Vehicle doors not latched in either the primary or secondary state may, during driving, open. This can increase the risk of a vehicle crash or compromise the safety of vehicle occupants.

Q1 Who do I contact if a member of the press contacts me about this recall?

A Please ensure that any Press enquiries are referred to the Jaguar Land Rover Corporate Affairs office.

Q2 Why is Jaguar Land Rover Limited recalling certain Land Rover vehicles?

A Customers have reported doors opening while the vehicle is in motion and no warning of an unlatched condition on the instrument cluster. This is considered to be a safety issue and a recall is required to remedy the defect.

Q3 Can you tell me more about what is wrong with the vehicles?

A In late January 2015 an electrical system specification difference was identified where a short circuit was applied to the keyless vehicle release motor directly after energizing for a keyless vehicle passive entry actuation whereas the latch supplier specification stated a preference for open circuit. This short circuit effectively turns the motor into a brake, slowing or in some cases stopping the keyless vehicle lever from returning to its home position. If the keyless vehicle lever is held away from its home position then the pawl is constantly in a state of clearance to the claw - the claw is free to rotate, and release. This means that during a standard door closure operation the latch appears to take the striker and the door can be closed with the side of the vehicle but the door is not securely retained by the latch.

Q4 How would the customer become aware of potentially having this concern?

A It is possible that in the condition described, the door will not close and latch bouncing back so illuminating the door ajar switch, but there are cases where the door can appear closed although not latched at which point there is little obvious indication of the issue.

Q5 Does this concern affect vehicle safety?

A Yes. Jaguar Land Rover has determined that this condition does pose a safety risk which is why a safety recall is being conducted.

Q6 Has Jaguar Land Rover Limited received many complaints?

A Jaguar Land Rover has received a number of customer complaints relating to this issue.

Q7 Have there been any accidents or injuries or fires?

A Jaguar Land Rover is unaware of any accident, injuries or fires which have been attributed to this issue.

Q8 How was the condition discovered?

A Jaguar Land Rover was alerted to this concern through quality data reporting systems.

Q9 How long has Jaguar Land Rover known about this problem?

A Jaguar Land Rover began investigating the in October 2014.

Q10 Is the defect leading you to any concerns regarding the reliability of a system, which is supposed to be designed and engineered for the passengers' safety? What type of measures are you planning to take?

A We have no concerns with the overall reliability of the vehicle. Jaguar Land Rover carefully monitors field data to ensure that any matters relating to safety and compliance are rigorously investigated.

Q11 What has Jaguar Land Rover done in production?

A Modifications have been made to remove the sensitivity of the door latch and associated mechanisms to the condition mentioned above.

Q12 What is the repair for this issue?

A Jaguar Land Rover will mail affected owners asking them to bring their vehicle to a Land Rover retailer of their choice to download the latest software making the motor open circuit in line with the latch manufacturers specification preference.

Q13 Which vehicles are affected by this recall?

A Certain 2013 to 2016 Model Year Land Rover Range Rover vehicles and certain 2014 to 2016 Model Year Land Rover Range Rover Sport vehicles built at the Solihull (UK) Assembly Plant from May 9, 2012 to March 12, 2015.

Q14 Are other Jaguar Land Rover models affected by these actions?

A No other models are known to be affected by this condition, other than those listed on this document.

Q15 Are parts available to rework vehicles?

A Vehicle software is available for the rework.

Q16 How much will this recall cost Jaguar Land Rover?

A Cost was not a factor in deciding to recall these vehicles.

Q17 How do I know if my vehicle is affected?

A All owners of potentially affected vehicles will shortly receive a letter inviting them to contact a Land Rover authorized repairer for the work to be carried out.

Q18 How long does it take for the vehicle to be inspected and repaired?

A The work will be carried out as quickly and efficiently as possible in order to minimize inconvenience to customers and is expected to take 30 min to complete. Naturally, due to dealer schedules, vehicles may be required for longer.

Q19 Can I continue to drive my vehicle safely until it has been recalled?

A Customers are advised to contact a Land Rover authorized repairer should they have any concerns regarding their vehicles. Until such time as your vehicle is repaired, Jaguar Land Rover strongly recommend that all vehicle occupants are secured using the vehicle seat belts and that the driver observe any door open warnings displayed in the instrument pack.

Note: Please ensure that any Press enquiries are referred to the Jaguar Land Rover Corporate Affairs office.

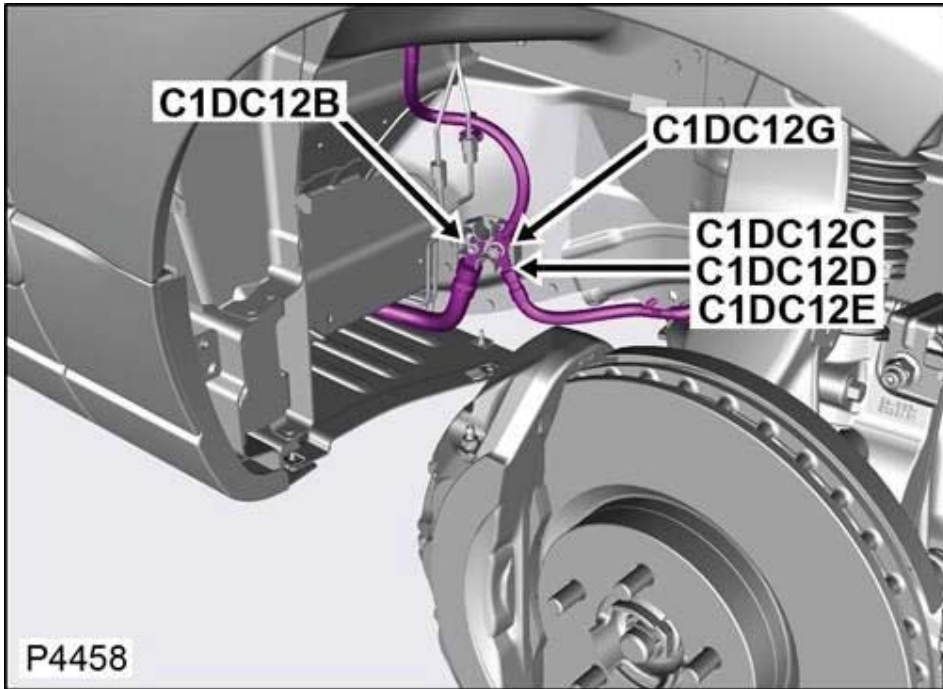



Special Service Message

NOTE: A Special Service Message is a formal communication issued by Land Rover and carries the same importance of a Technical Service Bulletin. An SSM is a quick method of communicating "Need To Know" information to the technical service community. SSM's may be issued in advance of a technical bulletin or may be the only communication on a given topic. All information contained in Land Rover technical communications are intended for use by trained, professional technicians with the knowledge, tools, and equipment required to complete the procedure correctly and safely. It informs the Technicians of conditions that may occur on some vehicles, or provides information that could assist in correct vehicle and diagnostic service.

SSM 60677 - Drivers door entry with vehicle in transport mode

Models : Range Rover / L405
Range Rover Sport / L494

Engineer :Richard Attwood

Date Last 26-05-2015 10:27:03

Updated :

Content :**ISSUE:** If the driver's door is closed at the exact time as the transit relay cuts power to the car and the door is 'soft closing', the soft close lever in the door latch may block the release of the latch claw from the door striker and thus prevent the door from opening externally.

As the vehicle will be in transport mode all doors except the driver's door will be locked, therefore if this issue occurs there will be no external access via any other door to allow access to the hazard warning switch to wake the car and allow the driver's door soft close motor to recover.

CAUSE: Transit relay cuts the power to the soft close motor causing the soft close lever in the door latch to block the release of the latch claw from the door striker and thus prevent the door from opening until the hazard warning switch is pressed. The soft close motor is a standalone module and therefore does not receive transport mode in order to inhibit operation during transport.

ACTION: All dealers and transport users are asked to ensure they have pressed the hazard switch and exited the vehicle, fully closing the door within 17 seconds to prevent the vehicle remaining in locked condition which then cannot manually be released.

Note: If the driver's door will not open and access to the vehicle is required carry out the following steps:

1. Carefully remove the lower external trim from the right hand front wing (see attachment step 1).
2. Carefully remove the fastenings from the lower rear section of the right hand front wheel arch liner and move the liner forward just enough to access the positive terminal post C1DC12B (see attachment step 2), open the plastic cover located on the terminal.
3. Using a suitable 12volt battery booster connect the positive lead to connector C1DC12B positive terminal post and connect the earth to a suitable earth point on the vehicle until the driver's door soft close motor has powered to its released position (this normally takes around 3 seconds) disconnect the battery booster from the vehicle, refit terminal cover and open the driver's door.
4. Carefully re-assemble wheel arch liner and exterior trim.

Version : 5

Attachments :



Special Service Message

NOTE: A Special Service Message is a formal communication issued by Land Rover and carries the same importance of a Technical Service Bulletin. An SSM is a quick method of communicating "Need To Know" information to the technical service community. SSM's may be issued in advance of a technical bulletin or may be the only communication on a given topic. All information contained in Land Rover technical communications are intended for use by trained, professional technicians with the knowledge, tools, and equipment required to complete the procedure correctly and safely. It informs the Technicians of conditions that may occur on some vehicles, or provides information that could assist in correct vehicle and diagnostic service.

SSM 68137 - 2014 Range Rover / Range Rover Sport Global Close Inoperative

Models : Range Rover / L405
Range Rover Sport / L494

Engineer :Stauss Ryan

Date Last 11-09-2013 15:57:25

Updated :

Content :[Concern](#)

A customer may complain that their Global Close feature is not working.

Cause

An inadvertent change to the vehicle has occurred which has disabled the feature. Engineering are currently investigating the concern.

Action

In the event of a customer concern their Global Close feature is not working, no further diagnostic action is necessary at this time. Engineering are working on a fix which will enable the Global Close feature to operate via the keyless locking sensor located on the exterior door handle as described in the Owner's Handbook. A fix communication will be issued shortly.

Version : 2

**Applicable to No
road side
assist? :**

Special Service Message

NOTE: A Special Service Message is a formal communication issued by Land Rover and carries the same importance of a Technical Service Bulletin. An SSM is a quick method of communicating "Need To Know" information to the technical service community. SSM's may be issued in advance of a technical bulletin or may be the only communication on a given topic. All information contained in Land Rover technical communications are intended for use by trained, professional technicians with the knowledge, tools, and equipment required to complete the procedure correctly and safely. It informs the Technicians of conditions that may occur on some vehicles, or provides information that could assist in correct vehicle and diagnostic service.

SSM 70758 - Keyless Vehicle Module updates and key replacement 13MY Only

Models : Range Rover / L405

Engineer : Richard Attwood

Date Last 06-01-2014 08:05:33

Updated :

Content : **Issue:** After programming (13MY only) Keyless Vehicle Module (KVM) using SDD DVD136 Patch 2, it will be noticed that the Passive Entry System operates only when the key is held close to the door handle, typically within a range of 10 centimetres. This is a default mode as a result of the software download.

In addition the smart key range within the vehicle may also be reduced and the 'Smart Key Not Found' message may appear on the Instrument Cluster. If this is the case, it will be necessary to follow the keyless start back up strategy with reference to the owner's handbook

Cause: Software compatibility issue now resolved with the release of DVD136; Patch file 4; Cal 160

Action: If the concern above is reported, re-configure the KVM software using DVD136; Patch file 4; Cal 160 or later.

Note: This SSM supersedes 70538 with immediate effect. All key programming and KVM software update activities may continue as normal (all model years) where necessary, using DVD136; Patch 4; Cal 160 or later.

Version : 2

Start

Please note down the answers to all questions in this flowchart and update the TA at the end of the process!

Note vehicle condition as delivered i.e.

- Mirrors folded in or out? (powerfold)
- Look through windows are the doors locked or not on the inside?
- Are the smart keys in the vehicle or outside? If possible photograph key location in vehicle before moving anything.

Confirm smart key is not being blocked by smart phone, laptop, phone chargers / invertors etc.
 NOTE:- You can do this by making sure that any of the above are turned off and removed from the vehicle.

To start the CAN Link Monitor without diagnostics in Symptom Driven Diagnostics (SDD):

1. Select 'START' (Windows 7) or the Windows icon (Windows XP) from bottom tool bar.
2. Select 'All Programs'.
3. Select 'JLR'.
4. Select 'SDD'.
5. Select 'CAN Link Monitor'. A pop-up box will show.
6. Select 'Capture'.
7. Select 'Configure'.
8. Select the vehicle from the Platform drop-down menu.
9. Make sure both the Low Speed and High Speed CAN Networks are selected.
10. Select 'MONITOR WITHOUT RUNNING DIAGNOSTICS' from the Filter range box
11. Insert USB Flash Drive into a USB port on the SDD machine.
12. Select the drive location for the USB Flash Drive from the Log File box.
13. Enter in the vehicle VIN as the File Name.
14. Select 'OK'.
15. Select 'CAPTURE'
16. Select 'START LOGGING'. A pop-up box will show 'Logging started successfully'.
17. Minimise the CAN Link Monitor window to the tool bar.
18. Start the vehicle function that needs to be monitored.
- ...

Press key fob button or Pull door handle on passive entry vehicles.
 (Please note what you have done.)

Doors unlock?
 Power fold Mirrors fold out? (if fitted)

If required, gain entry using key blade.

Does Alarm sound?
 Muffle sounder if required.

Check Battery Voltage and record it on the TA.
Do NOT disconnect the Battery.
 Connect Battery to a power source.

Do NOT press ignition/ Start button

Connect SDD machine

Start CAN link Monitor, start CAN log as per correct process.

Start SDD session

Check CAN integrity screen &
 Note any modules with a RED Cross.

Stop CAN Link Monitor and attach it to the TA.

Start another CAN link Monitor, start CAN log as per correct process.

Press start button without pressing brake pedal.
 NOTE:- this should be pressed for between 1-3s

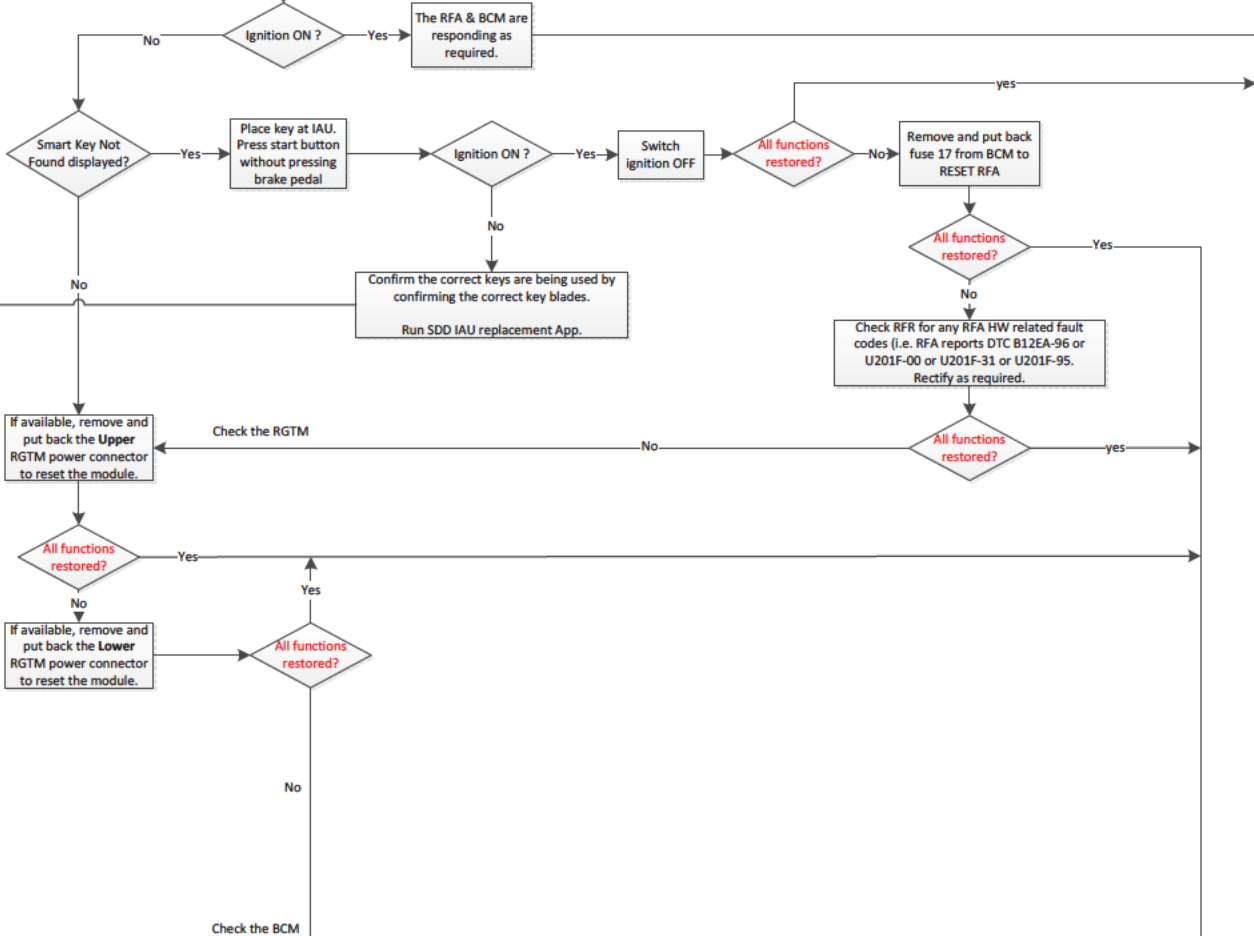

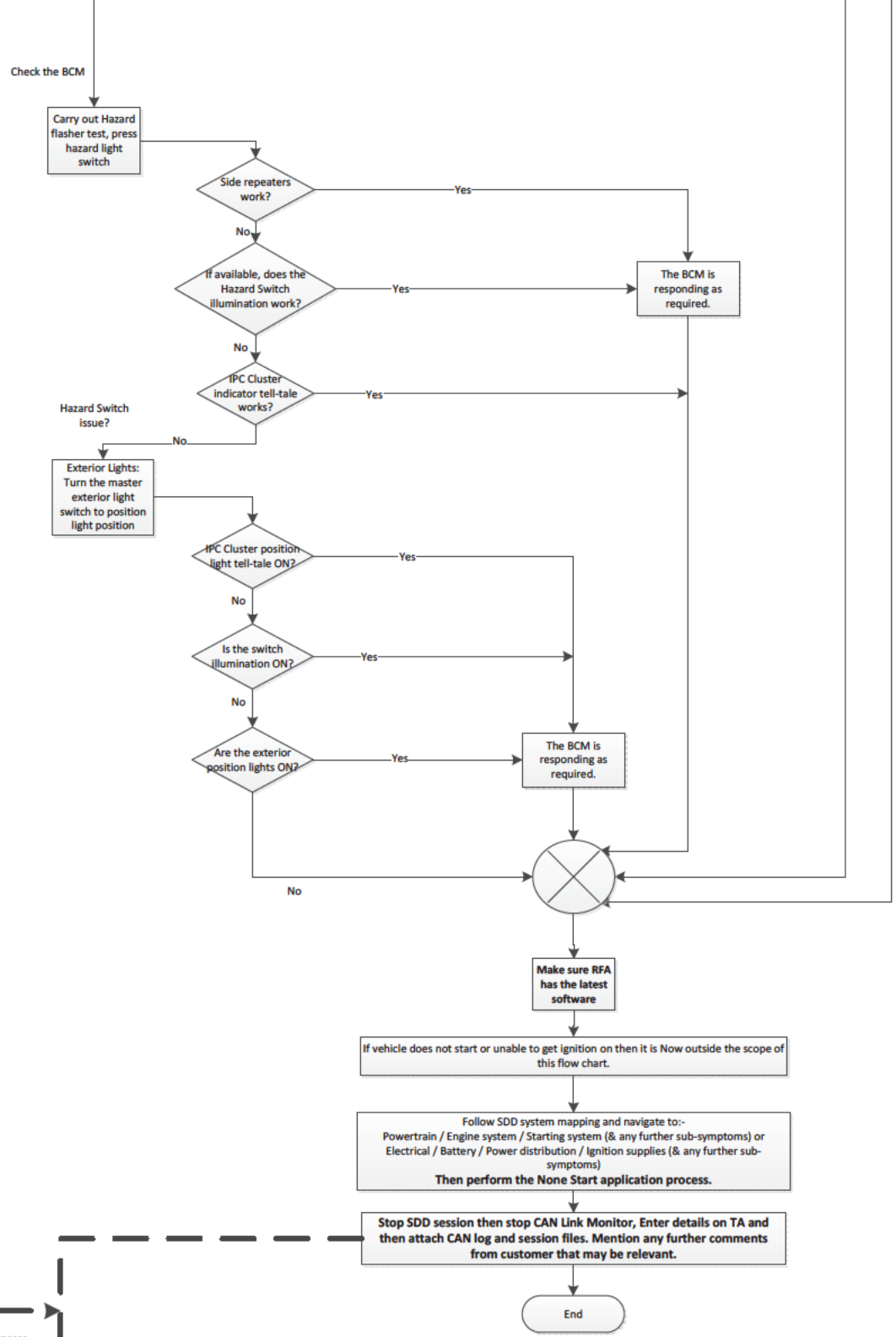

If the data is too large at the end of this process contact DTS for help in recovering this data. Or attach to TA.

- To stop the CAN Link Monitor :**
- ...
 - 19. When the vehicle function has completed, select CAN Link Monitor tab from the tool bar.
 - 20. Select 'CAPTURE'.
 - 21. Select 'STOP LOGGING'. A pop-up window will display 'Logging stopped successfully'.
 - 22. Locate the CAN Link Monitor file on the USB Flash Drive.
 - 23. Open file and make sure the data has recorded correctly.
 - 24. Close the file.
 - 25. Remove the USB flash drive from SDD machine.

Special Service Message

NOTE: A Special Service Message is a formal communication issued by Land Rover and carries the same importance of a Technical Service Bulletin. An SSM is a quick method of communicating "Need To Know" information to the technical service community. SSM's may be issued in advance of a technical bulletin or may be the only communication on a given topic. All information contained in Land Rover technical communications are intended for use by trained, professional technicians with the knowledge, tools, and equipment required to complete the procedure correctly and safely. It informs the Technicians of conditions that may occur on some vehicles, or provides information that could assist in correct vehicle and diagnostic service.

SSM 71870 - Unable To Unlock / Start Vehicle With Smart Key

Models : Discovery 4 / L319
Discovery Sport / L550
Evoque / L538
Freelander 2 / L359
Range Rover / L405
Range Rover Sport / L320
Range Rover Sport / L494

Engineer : Simon Bucknall

Date Last : 19-08-2015 15:27:58

Updated :

Content : Models affected

Discovery 4/LR4 - L319 -13MY onwards
Range Rover (All New) / L405 – 13MY onwards
Range Rover Evoque / L538 – 13MY onwards
Range Rover Sport / L320 – 13MY
Range Rover Sport L494 (All new) – 14MY onwards
Freelander 2/LR2- L359 – 13 and 14MY
Discovery Sport/L550-16MY onwards

Issue

Land Rover are currently investigating Body Control Modules (BCM) and Remote Function Actuators (RFA) and associated components replaced for a non-start condition.

Following supplier analysis the modules have been categorised as "No Fault Found".

Cause

Currently under analysis.

Action

If a vehicle is presented with the following symptoms please follow the test procedure outlined below before consideration is given to component replacement:
Vehicle does not lock or unlock using the key fob, or passive entry exit is not functioning.

After gaining entry to the car using key blade it does not start.

Even if entry is possible to the car, the car does not start when start button is pressed.

The vehicle has not had a software download immediately prior to the failure.

Test procedure:

Please follow the test procedure as detailed in the flowchart attached. Please note the details at all decision points. If this process is unsuccessful in resolving the issue please submit a Technical Assistance(TA) request.

Also attached is the process for obtaining a can trace.

Please Note:

1. Do not disconnect the battery or perform a hard reset on the vehicle at least until this flow chart has been followed.
2. Do not disconnect or move any connectors on the BCM
3. If entry is gained in the vehicle with the key blade the alarm may sound, do not press the ignition switch to shut the alarm off instead muffle the alarm sounder first then follow the test process in the flowchart.

Attachments :



Jaguar Land Rover Limited 2000 - 2017 (Rel. 2647)

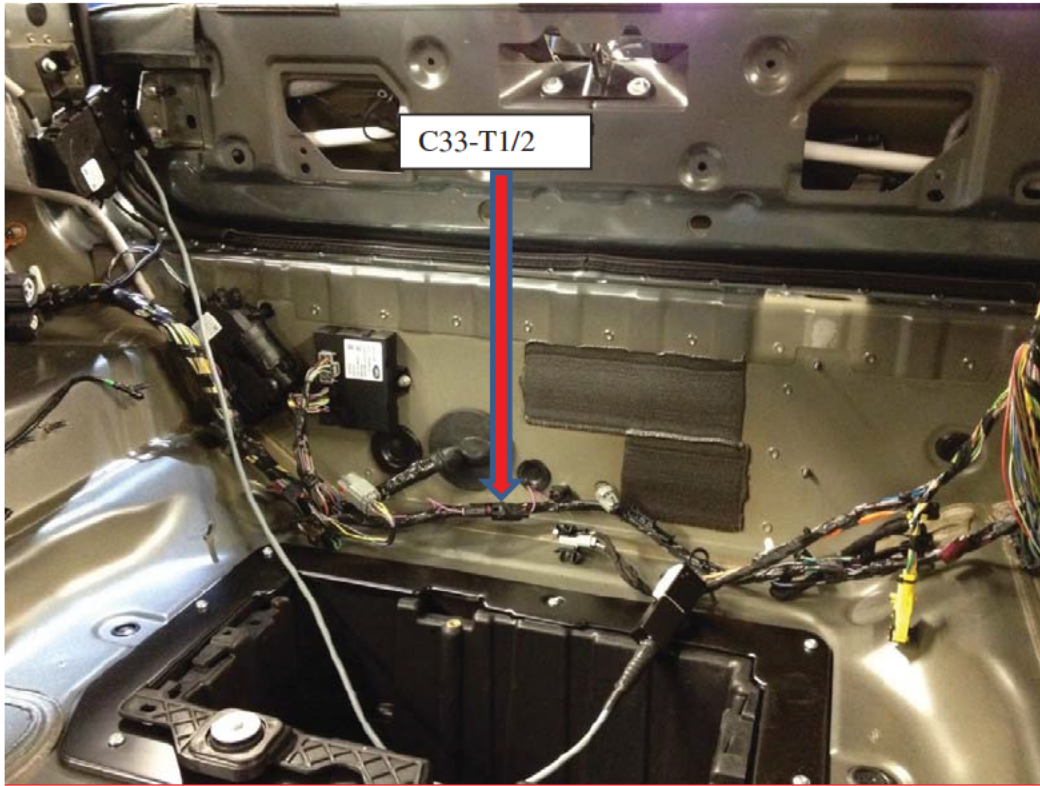

C33-T1/2

Special Service Message

NOTE: A Special Service Message is a formal communication issued by Land Rover and carries the same importance of a Technical Service Bulletin. An SSM is a quick method of communicating "Need To Know" information to the technical service community. SSM's may be issued in advance of a technical bulletin or may be the only communication on a given topic. All information contained in Land Rover technical communications are intended for use by trained, professional technicians with the knowledge, tools, and equipment required to complete the procedure correctly and safely. It informs the Technicians of conditions that may occur on some vehicles, or provides information that could assist in correct vehicle and diagnostic service.

SSM 71979 - 15MY Soft Close Feature Disabled For Drivers Door Only

Models : Range Rover / L405
Range Rover Sport / L494

Engineer : Richard Attwood

Date Last : 24-09-2014 16:20:11

Updated :

Content : **Issue:** The door soft close feature is found to be inoperative on the driver's door only during Pre Delivery Inspection (PDI).

Cause: At 15MY onwards a new feature is introduced that disables the driver's door soft close cinch motor (where fitted) for transportation purposes. As part of the PDI it will be necessary to reconnect C33-T1/2 (located at the rear of the spare wheel well) to enable the soft close feature.

Action: Whilst carrying out the transit relay removal step of the PDI and with the battery negative terminal disconnected:

1. Release the transit tape at connector C33-T1/2 (please see attachment for connector location)
2. Re-connect C33-T1/2
3. Check soft close operation for all closures.

Note: The PDI manual and check sheet will be updated in due course.

Version : 3

Attachments : 

Special Service Message

NOTE: A Special Service Message is a formal communication issued by Land Rover and carries the same importance of a Technical Service Bulletin. An SSM is a quick method of communicating "Need To Know" information to the technical service community. SSM's may be issued in advance of a technical bulletin or may be the only communication on a given topic. All information contained in Land Rover technical communications are intended for use by trained, professional technicians with the knowledge, tools, and equipment required to complete the procedure correctly and safely. It informs the Technicians of conditions that may occur on some vehicles, or provides information that could assist in correct vehicle and diagnostic service.

SSM 71984 - Second Generation `Smart Key Health Check` Function on SDD

Models : Discovery 3 / L319
Discovery 4 / L319
Evoque / L538
Freelander 2 / L359
Range Rover / L405
Range Rover / L322
Range Rover Sport / L320
Range Rover Sport / L494

Engineer : Bollettieri Thomas

Date Last : 01-10-2014 21:29:55

Updated :

Content : **UPDATED:** Version 2 of the PDF attachment has been expanded to include screenshots and text that further clarifies the functionality and behavior of this application.

Jaguar Land Rover North America Service Diagnostics urges all SDD users to become familiar with this advanced diagnostic aid for all vehicles equipped with Second Generation Smart Key technology.

Overview: The service function titled "Security - Smart Key Health Check" is a very comprehensive and interactive aid to quickly verify the status of the vehicle's smart key system.

This application can reliably verify many important details about this system.

- RF antenna functionality (receive data from keys)
- Key/Transmitters (send data from keys)
- LF antenna in center console (trigger keys to transmit data for passive starting)
- Key status (programmed, not programmed, programmed to another vehicle)
- Key Battery (state of charge)

For more details please see the attached PDF file.

Version : 4

**Applicable to No
road side
assist? :**

Attachments :

Special Service Message

NOTE: A Special Service Message is a formal communication issued by Land Rover and carries the same importance of a Technical Service Bulletin. An SSM is a quick method of communicating "Need To Know" information to the technical service community. SSM's may be issued in advance of a technical bulletin or may be the only communication on a given topic. All information contained in Land Rover technical communications are intended for use by trained, professional technicians with the knowledge, tools, and equipment required to complete the procedure correctly and safely. It informs the Technicians of conditions that may occur on some vehicles, or provides information that could assist in correct vehicle and diagnostic service.

SSM 71992 - Range Rover Soft Close Plunger Fitment Templates

Models : Range Rover / L405

Engineer : Adrian Pickard

Date Last 01-10-2014 09:53:28

Updated :

Content : Issue

Customers may report that the L405 Rear Soft Close (Door Lock) feature does not work or is intermittent in operation

Cause

Supplimentary information for TSB.

Action

Please follow the Instructions as detailed in TSB LTB00699. However the attached templates will be need to be printed in order for the Technician to drill the Hole for the Soft Close Plunger fixings for both rear doors. Guidelines on Printing are also attached

Please Note:-

It is extremely important that both the templates are set to "Print Actual Size" on your Printers and **not** "Fit to Page". The templates will need to be printed on A3 (11.7"x16.5") (297mm x 420mm) paper. Please validate that the Templates are the correct size by measuring the 100mm Line on the Template with a Ruler /Tape measure. Once you are certain you have printed off the correct size template it will need to be cut from the paper.

Caution:- Failure to any do any of the above will mean that the Holes for the Soft Close Plunger fixings could be drilled in the wrong position.

Version : 2

Applicable to No
road side

assist? :

Attachments :

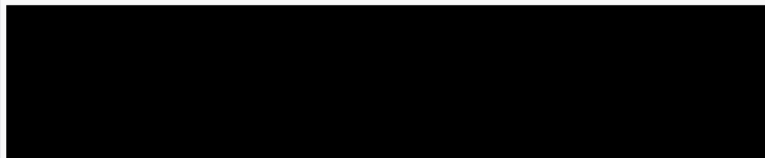

Special Service Message

NOTE: A Special Service Message is a formal communication issued by Land Rover and carries the same importance of a Technical Service Bulletin. An SSM is a quick method of communicating "Need To Know" information to the technical service community. SSM's may be issued in advance of a technical bulletin or may be the only communication on a given topic. All information contained in Land Rover technical communications are intended for use by trained, professional technicians with the knowledge, tools, and equipment required to complete the procedure correctly and safely. It informs the Technicians of conditions that may occur on some vehicles, or provides information that could assist in correct vehicle and diagnostic service.

SSM 72130 - Range Rover (LG) and Range Rover Sport (LW) Side Door latch concern

Models : Range Rover / L405
Range Rover Sport / L494

Engineer : Adrian Pickard

Date Last : 27-02-2015 10:40:19

Updated :

Content : Issue:

A customer may report that the side door latch is unable to retain the door in the closed position on their vehicle.

Cause:

Under investigation, updated SSM to replace only affected parts.

Action:

If your dealership lies within mainland UK (GBR), Germany (DEU), or the United Arab Emirates (ARE) please do not attempt to repair the vehicle. Raise a TA and retain the vehicle until your TA is responded to, provided it does not inconvenience the customer. If it will inconvenience the customer, take note of which door is failing to latch closed and only replace the affected latch on the vehicle.

It is important that you use latches from a known supplier batch with a date code after 171214, or have a paintmark in the area indicated in the attachment. If the paintmark is present, the latch is ok to use with any date code.

Do not use latches available at your dealership without the markings / date code highlighted in the attachment. New latches must be ordered from your Service Parts provider. Retain all the latches and be prepared to return them to Land Rover Engineering via the PRR process.

If your dealership does not lie within these regions, take note of which door is failing to latch closed and then replace only the affected latch on the vehicle with approved new parts as stated and report this action by submitting an EPQR.

Attached file lists the part numbers affected

Version : 4

**Applicable to No
road side**

assist? :

Attachments :

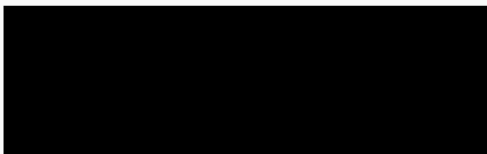

Special Service Message

NOTE: A Special Service Message is a formal communication issued by Land Rover and carries the same importance of a Technical Service Bulletin. An SSM is a quick method of communicating "Need To Know" information to the technical service community. SSM's may be issued in advance of a technical bulletin or may be the only communication on a given topic. All information contained in Land Rover technical communications are intended for use by trained, professional technicians with the knowledge, tools, and equipment required to complete the procedure correctly and safely. It informs the Technicians of conditions that may occur on some vehicles, or provides information that could assist in correct vehicle and diagnostic service.

SSM 72290 - L405 Range Rover & L494 Sport Squeaks & Creaks Diagnostic's

Models : Range Rover / L405
Range Rover Sport / L494

Engineer : Adrian Pickard

Date Last 01-06-2015 07:52:24

Updated :

Content : Issue

L405 Range Rover and L494 Range Rover Sport Customers may report a 'Creak' or 'Squeak' from either of the Front or Rear Doors

Cause

Possible causes could be :-

- Obstruction within door aperture or door latch
- Incorrect door striker- Alignment/adjustment
- Door frame seal coating
- Worn/damaged door frame seal(s)
- Worn/damaged door aperture seal(s)
- Paint wear

Action

Pinpoint diagnostics within Topix have been newly created to help the Technician diagnose the correct route cause and resolution. These can be found in the Workshop Manual -*Body & Paint – 501-00 – Diagnosis & Testing –Squeaks and Rattles.*

Version : 2

**Applicable to No
road side
assist? :**

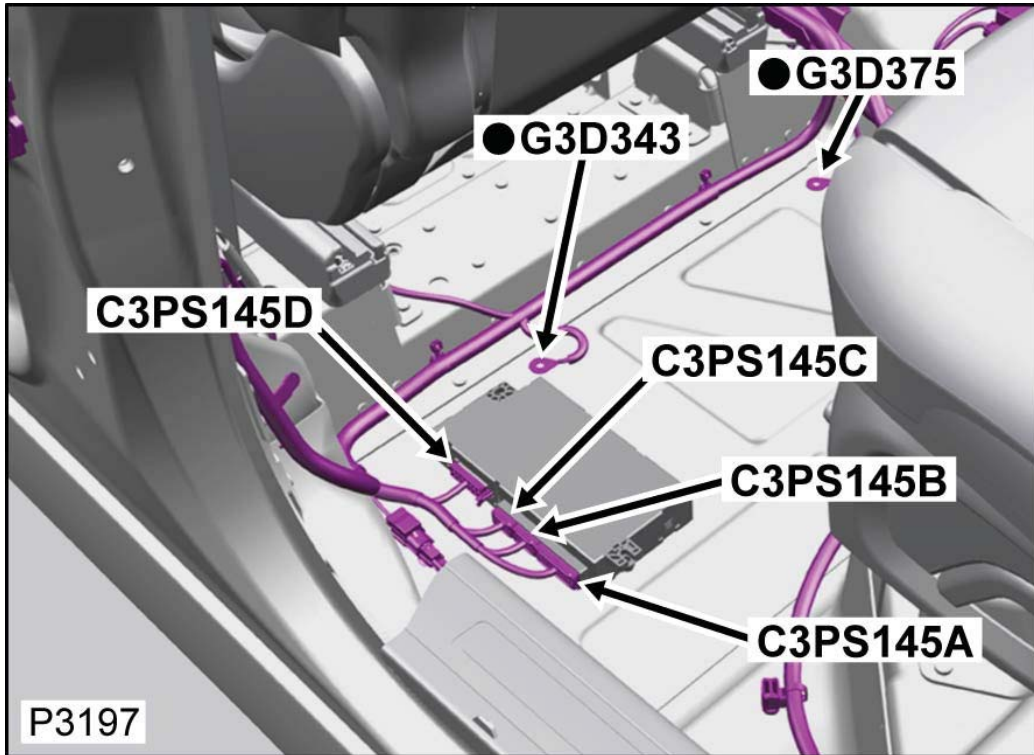

Special Service Message

NOTE: A Special Service Message is a formal communication issued by Land Rover and carries the same importance of a Technical Service Bulletin. An SSM is a quick method of communicating "Need To Know" information to the technical service community. SSM's may be issued in advance of a technical bulletin or may be the only communication on a given topic. All information contained in Land Rover technical communications are intended for use by trained, professional technicians with the knowledge, tools, and equipment required to complete the procedure correctly and safely. It informs the Technicians of conditions that may occur on some vehicles, or provides information that could assist in correct vehicle and diagnostic service.

SSM 72558 - New Remote Function Actuator (RFA) cannot communicate with SDD when programming as new.

Models : Discovery 4 / L319
Discovery Sport / L550
Evoque / L538
Range Rover / L405
Range Rover Sport / L494

Engineer :Umney Ade

Date Last :12-06-2017 09:33:47

Updated :

Content :Issue:

L405 – Range Rover: From 14MY onwards
L494 – Range Rover Sport: From 14MY onwards
L538 – Range Rover Evoque: From 14MY onwards
L550 – Discovery Sport: From 15MY onwards
L319 – LA- Discovery 4 - From 16MY onwards

When fitting a new RFA with a module part number of:

FK72-19H440 - AE
FK72-19H440 - BE
FK72-19H440 - AF
FK72-19H440 - BF

SDD cannot communicate with the RFA. This will be displayed as a red 'X' for the RFA in the SDD vehicle specification screen.

Note:

This concern does not apply to modules with a manufacturing date after **12 September 2016**, which can be identified by looking at the date stamp printed on the module.

Cause:

The new RFA module supplied is manufactured with pre-flashed software for 'DUAL CAN' vehicles. These vehicles are 'MULTICAN' and not 'DUAL CAN' and will not communicate with SDD for programming or update without completing the action instructions detailed below.

Action:

Complete the following steps when replacing an RFA:

1. Use TOPIx to identify the 5 Amp fuse that supplies the power to pin 20 of the RFA.
2. Set the vehicle ignition to 'ON' placing the Smart Key against the Immobilizer Antenna Unit (IAU).

3. Disengage the Electronic Parking Brake (EPB).
4. Locate the fuse box in the vehicle.
5. Remove and refit the 5 Amp fuse for the RFA.
6. Re-fresh the data collect and confirm if the RFA is now communicating.
7. Select Configure new modules - Keyless vehicle module and follow the on screen instructions in SDD.

NOTE: If the ignition cannot be switched on by placing the Smart Key against the IAU, complete the following steps:

1. Remove the 5 Amp fuse for the RFA.
2. Run the immobilization procedure.
3. When the ignition comes on, disengage the parking brake and immediately refit the RFA fuse.
4. Re-fresh the data collect and confirm if the RFA is now communicating.
5. Select Configure new modules - Keyless vehicle module and follow the on screen instructions in SDD.

Version : 8

Special Service Message

NOTE: A Special Service Message is a formal communication issued by Land Rover and carries the same importance of a Technical Service Bulletin. An SSM is a quick method of communicating "Need To Know" information to the technical service community. SSM's may be issued in advance of a technical bulletin or may be the only communication on a given topic. All information contained in Land Rover technical communications are intended for use by trained, professional technicians with the knowledge, tools, and equipment required to complete the procedure correctly and safely. It informs the Technicians of conditions that may occur on some vehicles, or provides information that could assist in correct vehicle and diagnostic service.

SSM 72738 - "Bonnet Open" Signal Showing on IPC

Models : Discovery 4 / L319
Discovery Sport / L550
Evoque / L538
Range Rover / L405
Range Rover Sport / L494

Engineer : Gary Payne

Date Last : 18-04-2016 11:11:28

Updated :

Content : **Issue:** The bonnet open warning light is on but the bonnet *appears* closed. This can cause the alarm to trigger or the vehicle to not lock.

Cause: The following key potential route causes have been identified:

- The bonnet appears closed but is actually not latched on one side – adjustment issue
- The incorrect signal is being received from the "bonnet ajar" micro switch – part electrical issue
- The latch is unable to close – part mechanical issue

Action: Please follow the below steps to rectify the customer concern:

Note: The bonnet latch system is designed to not require ANY lubrication to ANY part of the system. Lubrication can impact the performance and should not be done under any circumstances

1. Check IPC for the "Bonnet Open" warning light (see attachment, figure 1)
2. Check Message Centre for Alarm Trigger History (see attachment, figure 2)
- This will verify if an alarm is being triggered by the bonnet latch or a different part of the vehicle.
3. Check retention of BOTH Bonnet Latches (see attachment, figure 3)
- Lift both front corners of the bonnet *separately* to ensure both latches are fully engaged. If a latch is not latching adjust it upwards, close the bonnet and check for retention
4. Ensure the electrical harness connector is securely fitted (see attachment, figure 4)
- Reconnect if required
5. Verify routing, engagement with latch and operation of the bonnet release cable
Ensure that the micro switch lever is not damaged / deformed during this check
6. Check operation of the mechanical latching and correction of the customer complaint following the previous actions
7. If the fault persists replace the offending latch. If the vehicle is post the assured VIN below raise an EPQR with all relevant details included

Vehicle VIN List:

Discovery (L319) :- LA798397

Range Rover (L405) :- LG264004

Range Rover Sport (L494) :- LW562669 & 639143

Evoque (L538) :- LV103218

Discovery Sport (L550) :- LC571296

Version : 2

Applicable to Yes

road side

assist? :

Attachments 

Special Service Message

NOTE: A Special Service Message is a formal communication issued by Land Rover and carries the same importance of a Technical Service Bulletin. An SSM is a quick method of communicating "Need To Know" information to the technical service community. SSM's may be issued in advance of a technical bulletin or may be the only communication on a given topic. All information contained in Land Rover technical communications are intended for use by trained, professional technicians with the knowledge, tools, and equipment required to complete the procedure correctly and safely. It informs the Technicians of conditions that may occur on some vehicles, or provides information that could assist in correct vehicle and diagnostic service.

SSM 73296 - Exterior Door Handles

Models : Discovery Sport / L550
Discovery Sport / L550 (Brazil 99J)
Evoque / L538
Evoque / L538 (Brazil 99J)
Range Rover / L405
Range Rover Sport / L494

Engineer : Ian Cavanagh

Date Last : 21-03-2017 09:51:33

Updated :

Content : Issue:

Defective exterior door handles are being returned incomplete or dismantled.

Cause:

Exterior door handles are being dismantled at Retailers.

Action:

- Under no circumstance should the handle be dis-assembled.
- Disassembling the handle, then reassembling, will mean the lock/unlock module will not be fully bonded to the strap outer and inner which can lead to lock / unlock performance issues due to water ingress.
- Disassembling the handle can also damage the strap inner to outer clips leading to squeaks, rattles and poor feel during operation.
- These units are required to be returned in an assembled state.

Version : 2

Special Service Message

NOTE: A Special Service Message is a formal communication issued by Land Rover and carries the same importance of a Technical Service Bulletin. An SSM is a quick method of communicating "Need To Know" information to the technical service community. SSM's may be issued in advance of a technical bulletin or may be the only communication on a given topic. All information contained in Land Rover technical communications are intended for use by trained, professional technicians with the knowledge, tools, and equipment required to complete the procedure correctly and safely. It informs the Technicians of conditions that may occur on some vehicles, or provides information that could assist in correct vehicle and diagnostic service.

SSM 73399 - Key Programming Application Fails On Range Rover pre 17 MY With FK72 KVMs Fitted

Models : Range Rover / L405

Engineer : Ludlow Joe

Date Last : 26-05-2017 10:13:10

Updated :

Content : ISSUE:

When attempting to program vehicle keys either as a standalone application or as part of a module programming application, there may be an error noticed and the application aborts leaving the keys un-programmed.

CAUSE:

There has been a revision made to the Keyless Vehicle Module (KVM) which, in some cases, will cause an error during key programming.

Note: This issue will only affect vehicles fitted with KVM hardware with a prefix of **FK72**. The KVM hardware prefix can be checked by performing a 'Network Integrity Test' using the JLR Approved Diagnostic Equipment and looking at the information under the KVM heading on the row labelled 'F111'.

ACTION:

This workaround will load a software file to SDD using the Manual Patch Update process.

This Manual Patch will stay on the JLR Approved Diagnostic Equipment.

NOTE: When an SDD software update has been applied to the JLR Approved Diagnostic Equipment, this Manual Patch will need to be re-applied until the permanent corrective action is delivered.

1. Restart the JLR Approved Diagnostic Equipment.
2. Login to SDD.
3. Select 'Continue' on the SDD Warning screen.
4. Select 'Settings' tab.
5. Select 'System Utilities'.
6. Select 'Manual Patch Update'.
7. A pop-up will be displayed for Manual patch selection dialog box.
8. Enter **'MP_JLR_L0057'** in the Manual patch selection dialog box.
9. Select 'OK'.
10. The 'Software Management Wizard' will then download the fix file.
11. The Manual patch update information pop up will ask 'Do you want to install the update now?' Select 'OK'.
12. Select 'OK' when the message 'Please shut down SDD before continuing' is displayed. **DO NOT SHUT DOWN THE JLR APPROVED DIAGNOSTIC EQUIPMENT.**
13. 'Please wait' message is displayed.
14. Select 'OK' when the 'Package has been installed' message is displayed.
15. Select 'OK' in the Manual patch update information pop up.

16. Close the Internet Explorer Window where the SDD program runs.
17. Start a new SDD session.
18. Complete the Required Application.
19. Close the SDD session.
20. Restart the JLR Approved Diagnostic Equipment.

If this Manual patch fails to correct the concern then a Technical Assistance should be submitted to Local Technical Support (LTS).

Note: If this manual patch is not being installed on all SDD machines you may wish to consider labelling the machine.

PERMANENT CORRECTIVE ACTION:

The Information Bulletin and Manual Patch will be expired and an updated bulletin will be released advising the future SDD software level that a permanent solution is released on.

Version : 2

Applicable to No

road side assist? :

Special Service Message

NOTE: A Special Service Message is a formal communication issued by Land Rover and carries the same importance of a Technical Service Bulletin. An SSM is a quick method of communicating "Need To Know" information to the technical service community. SSM's may be issued in advance of a technical bulletin or may be the only communication on a given topic. All information contained in Land Rover technical communications are intended for use by trained, professional technicians with the knowledge, tools, and equipment required to complete the procedure correctly and safely. It informs the Technicians of conditions that may occur on some vehicles, or provides information that could assist in correct vehicle and diagnostic service.

SSM 73432 - Use of Inline Diagnostic Unit 2 (IDU2) and Noise, Vibration and Harness (NVH) Sensor

Models : Defender / L316
Discovery / L462
Discovery 1
Discovery 2 / L318
Discovery 3 / L319
Discovery 4 / L319
Discovery Sport / (China L2C)
Discovery Sport / L550
Discovery Sport / L550 (Brazil 99J)
Evoque / (China L2C)
Evoque / L538
Evoque / L538 (Brazil 99J)
Freelander / L314
Freelander 2 / L359
Range Rover / L405
Range Rover / L322
Range Rover / P38a
Range Rover Classic
Range Rover Sport / L320
Range Rover Sport / L494
Range Rover Velar / L560

Engineer :Knott Philip

Date Last 20-06-2017 14:02:20

Updated :

Content :**NOTE:** Please note that this Special Service Message has been issued to provide information about the Inline Diagnostic Unit 2 (IDU2) and Noise, Vibration and Harshness (NVH) Sensor only.

What is the IDU2 and the NVH Sensor?

The IDU2 and NVH Sensor are mandatory tools designed to be used with Jaguar Land Rover (JLR) diagnostic tools to assist in the diagnosis of 'hard to diagnose' components. The IDU2 and NVH Sensor provide clear Pass/Fail results to the technician.

How do I use the IDU2 and NVH Sensor?

The IDU2 and NVH Sensor can be used in conjunction with JLR diagnostic tools to complete multiple tests on the vehicle. The JLR diagnostic tool will prompt the technician when the IDU2 or NVH Sensor should be used during diagnosis. Step by step instructions will be displayed throughout the application for the technician to follow.

When should the IDU2 and NVH Sensor be used?

The diagnostic tool will present the IDU2 and NVH Sensor applications as recommendations when the relevant customer symptoms and DTCs are present. Please note that the diagnostic tool will only show the IDU2 and NVH Sensor applications when they are needed – if the diagnostic tool does not present applications for the IDU2 and NVH Sensor, these applications do not need to be used.

How should the IDU2 and NVH Sensor be set up?

Once the IDU2 or NVH Sensor application has been launched, detailed instructions on the connection and setup of the tools will be displayed to the technician.

The IDU2 is a 'plug and play' device. The IDU2 completes a cable test to confirm that the cable is working correctly before the diagnostic test begins. Each cable is digitally signed, meaning that the IDU2 can detect if the wrong cable has been plugged in and will advise the technician of the correct cable to connect.

The NVH Sensor connects to the Jaguar Land Rover (JLR) Approved Diagnostic Equipment by a Bluetooth connection. Instructions on how to connect the unit using Bluetooth are provided once an NVH Sensor application has been launched. Please note that the NVH Sensor requires charging before use.

Available applications for IDU2 and NVH sensor

The following applications are currently available for the IDU2 and NVH Sensor.

IDU2 Applications:

- **Turbocharger** – Allows objective diagnosis of turbocharger components. Managed through a combination of inline and independent component tests, the IDU2 is capable of distinguishing between wiring harness or component faults.
- **Exhaust Gas Recirculation valve** – Allows objective diagnosis of EGR components. Managed through a combination of inline and independent component tests, the IDU2 is capable of distinguishing between wiring harness or component faults.
- **Low pressure fuel pump (Diesel)** – Allows objective diagnosis of the fuel tank fuel pump through non-intrusive methods. The IDU2 will analyse the current draw of the fuel pump driver module (FPDM) through the easily accessible fuse panels to determine if the performance of the fuel pump is within specification.
- **Petrol fuel pump (Low pressure)** – Allows objective diagnosis of the fuel tank fuel pump through non-intrusive methods. The IDU2 will analyse the current draw of the fuel pump driver module (FPDM) through the easily accessible fuse panels to determine if the performance of the fuel pump is within specification.
- **Door latch (C1Latch, Unilatch)** – Allows objective diagnosis of door(s) latch operation through non-intrusive methods. The IDU2 will analyse the current draw from the door latches through the easily accessible fuse panels, this application provides the end user with a decision on whether or not an interior door trim must be removed for further investigation of the door latch.
- **Relative compression test (V6 3.0L S/C Petrol, GTDi 2.0L Petrol, V8 5.0L S/C Petrol, V8 5.0L Petrol)** – Allows objective compression checks for four, six and eight cylinder petrol engines. Connecting directly to the crankshaft position (CKP) sensor and ignition coil (or camshaft position (CMP) sensor), the IDU2 is capable of analysing characteristic variations in the engine speed as compression loss and identify the offending cylinder(s) (up to two faulty cylinders).
- **Remote function actuator** – Allows the user to test the remote function actuator motor on the latch from the Remote Function Actuator (RFA) module's fuse. By connecting the IDU2 to the RFA's fuse and following the instructions from the application, the user will be given a PASS/FAIL result at the end of the test depending on the Current (Amps) performance of the motor.
- **Closing motor** – Allows the user to test the closing door motor from the fuse of the door module. By connecting the IDU2 to the appropriate door module's fuse and following the instructions from the application, the user will be given a PASS/FAIL result at the end of the test depending on the Current (Amps) performance of the motor.
- **Powerfold mirror operation** – Allows the user to test the power fold motor of a suspect mirror from the fuse of the door module. By connecting the IDU2 to the appropriate door module's fuse and following the instructions from the application, the user will be given a PASS/FAIL result at the end of the test depending on the Current (Amps) performance of the motor.
- **Windshield wiper park switch diagnostic** – Allows the user to interrogate

the speed of the wiper park position switch on the wiper motor against the wipers and washers control switch. The user will be instructed to close the hood, have the engine running and actuate the front wipers and washers control switch to the maximum setting. The IDU2 will interrogate the switch's status against the feedback of the wiper park position switch on the motor. The user will be given a PASS/FAIL result at the end of the test depending on the speed of the motor.

- **Rear wiper park switch diagnostic** – Allows the user to interrogate the speed of the wiper park position switch on the wiper motor against the wipers and washers control switch. The user will be instructed to close the hood, have the engine running and actuate the rear wiper and washer control switch to the maximum setting. The IDU2 will interrogate the switch's status against the feedback of the wiper park position switch on the motor. The user will be given a PASS/FAIL result at the end of the test depending on the speed of the motor.
- **Roof opening panel** – Allows the use to interrogate the opening panel blind and the power glass panel if fitted to the vehicle from the fuses of the roof opening panels. By connecting the IDU2 to the appropriate fuse and following the instructions from the application, the user will be given a PASS/FAIL result at the end of the test depending on the Current (Amps) performance of the motor/s and the different switch status.

NVH Sensor Applications:

- **Accessory drive belt** – Allows objective diagnosis of accessory drive pulley balance. Out of balance pulleys are flagged for further investigation.
- **Transfer case** – Allows objective diagnosis of the transfer case noise through the measurement of vibrations on the outer casing. This vibration can be characterised and objectively analysed.
- **Turbocharger** – Allows objective diagnosis of turbocharger mechanical faults. The NVH Sensor analyses the noise levels to determine whether the component is faulty.
- **Differential Unit (Front and Rear)** – Allows objective diagnosis of the differential unit noise through the measurement of vibrations on its outer casing. This vibration can be characterised and objectively analysed.
- **Wheel imbalance** – Allows for repeatable objective tests which checks for wheel imbalances present in the front and rear wheels of the vehicle. By attaching the NVH sensor to the steering wheel using the steering wheel strap, the NVH sensor is capable of analysing the vibrations on the steering wheel to identify the location(s) of wheel imbalances that are present.

IDU2 and NVH Sensor Training

Personal Study Module (PSM) PDAX00777 – SDD Features and Functions Lesson 5 is available on Excellence for all technicians. This PSM introduces the IDU2 and NVH Sensor, focusing on how the tools can be used in conjunction with SDD to successfully diagnose faults. Detailed descriptions about the IDU2 and NVH Sensor applications are available within this PSM.

IDU2 and NVH Sensor Special Tool Release Notes

The following Special Tool Release Notes are available on TOPIx for the IDU2:

LSST067v2 – Inline Diagnostic Unit (IDU2) and Noise, Vibration and Harshness (NVH) Sensor

LSST104 – Additional IDU2 Diagnostic Cables

LSST106 – Additional IDU2 Diagnostic Cables

Version : 2

**Applicable to No
road side
assist? :**

Special Service Message

NOTE: A Special Service Message is a formal communication issued by Land Rover and carries the same importance of a Technical Service Bulletin. An SSM is a quick method of communicating "Need To Know" information to the technical service community. SSM's may be issued in advance of a technical bulletin or may be the only communication on a given topic. All information contained in Land Rover technical communications are intended for use by trained, professional technicians with the knowledge, tools, and equipment required to complete the procedure correctly and safely. It informs the Technicians of conditions that may occur on some vehicles, or provides information that could assist in correct vehicle and diagnostic service.

SSM 73451 - De-activation of keyless entry/ locking

Models : Discovery / L462
Range Rover / L405
Range Rover Sport / L494

Engineer :Richard Attwood

Date Last 29-06-2017 09:17:56

Updated :

Content :**Issue:** Land Rover has recently been made aware via aftersales clinic feedback that some customers are not aware of the range of vehicle security personalisation options available to them. In particular the feature 'keyless entry/ locking' (also known as 'passive entry/ exit') has an option to de-select functionality if required by the customer without the need of Symptom Driven Diagnostics or Pathfinder.

A customer may request the feature be de-selected for any of the following reasons:

1. Prefer not to have feature active as some customers assume incorrectly that the vehicle is not locked whilst they are out of range of the vehicle, even though the system is functioning correctly and the vehicle is secure. A customer may simply prefer to unlock/ lock the vehicle by pressing the appropriate button on the smart key.
2. In rare circumstances where the Radio Frequency (RF) signal sent from the smart key to the vehicle on approach may be intercepted by a 3rd party in an attempt to clone an additional key for unauthorised access to the vehicle.

Cause: Vehicle security options not conveyed during customer hand over.

Action: The steps to disable keyless entry/ locking using the smart key are as follows:-

1. **Open the driver's door.** To avoid inadvertent operation of the feature the driver door must be open. If other doors, including trunk and boot are open, the sequence will not work.
2. **Press 'approach light' key fob button 3 times** within 3 seconds.
3. **Press the 'lock or unlock' button** on the same smart key within 1 second.
 - a. 'Lock' will enable passive entry/ exit
 - b. 'Unlock' will disable passive entry/ exit

Note: If any other button is pressed at any point or if a valid button is pressed too late, the sequence will abort.

Note: Upon valid detection of the button press sequence, the vehicle will acknowledge the event by automatically flashing the headlamps. The number of flashes may vary depending on the age of the vehicle and the type of lights fitted.

Note: Following the process above will disable/ enable the passive entry/ exit only. The passive start will not be affected.

Version : 2

Jaguar Land Rover Limited 2000 - 2017 (Rel. 2647)

Special Service Message

NOTE: A Special Service Message is a formal communication issued by Land Rover and carries the same importance of a Technical Service Bulletin. An SSM is a quick method of communicating "Need To Know" information to the technical service community. SSM's may be issued in advance of a technical bulletin or may be the only communication on a given topic. All information contained in Land Rover technical communications are intended for use by trained, professional technicians with the knowledge, tools, and equipment required to complete the procedure correctly and safely. It informs the Technicians of conditions that may occur on some vehicles, or provides information that could assist in correct vehicle and diagnostic service.

SSM 72391 - Important information reference the location of both keys at PDI

Models : Discovery Sport / L550
Range Rover / L405
Range Rover Sport / L494

Engineer : Simon Bucknall

Date Last : 25-08-2015 12:17:12

Updated :

Content : Vehicle Lines affected

Range Rover-L405 15my onwards
Range Rover sport-L494 15my onwards
Discovery Sport- L550 16my

Note

This phenomenon can only happen under specific circumstances; it is only when both keys are in close proximity of each other in the vehicle and requires the exterior door handle lock button to be pressed.

Issue

It has been highlighted that it is possible to lock the vehicle with both keys inside. Keys are held together by cable ties when delivered to the retailer.

Cause

Software error.

Action

This issue is currently under investigation. Until a fix communication is issued you are requested to ensure that if there is a requirement to lock the vehicle that both keys are removed before pressing the exterior handle lock button.

Version : 2

**Applicable to No
road side
assist? :**

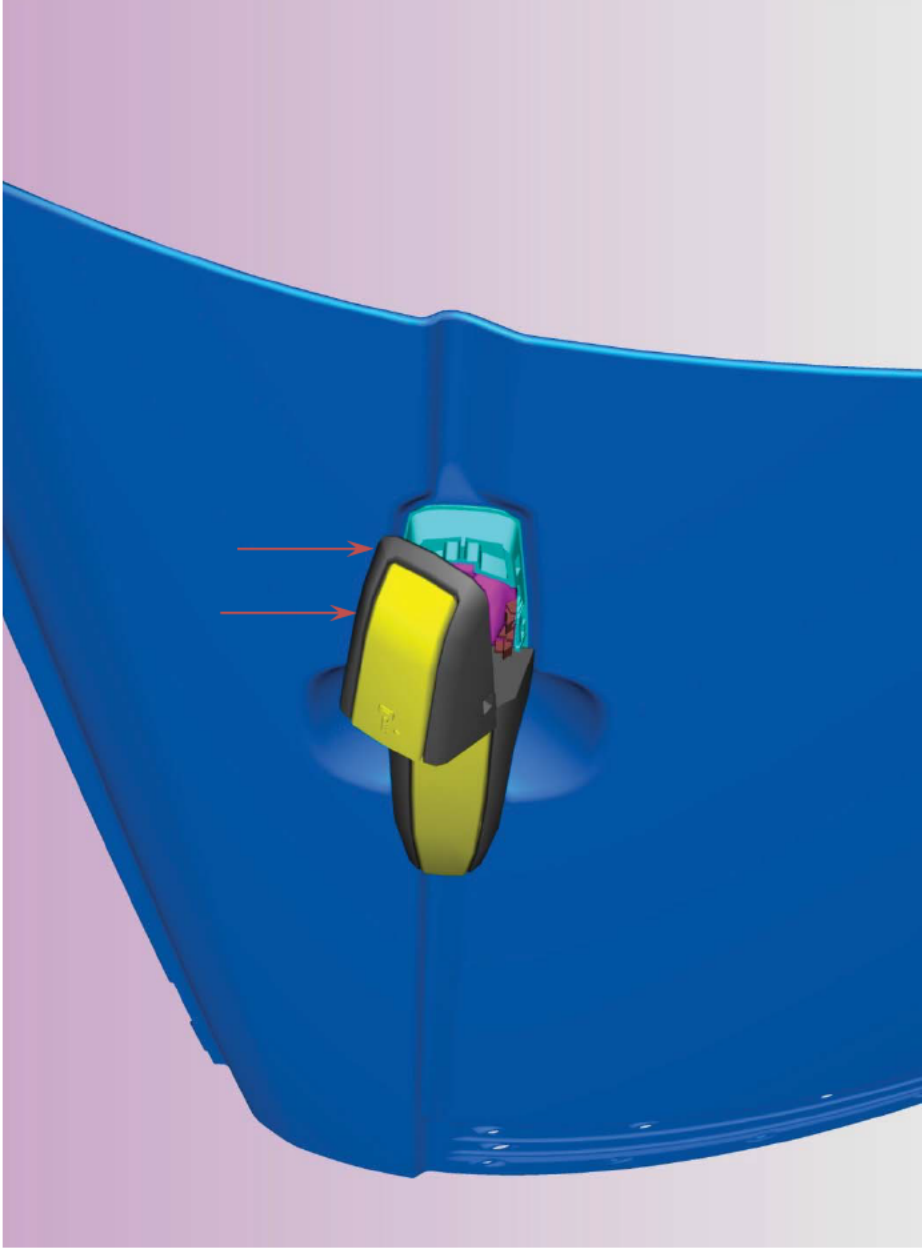

Approach the vehicle with the Door Lock Cover tilted upwards. There is a pair of clipping features that need to be carefully located into the gasket behind.

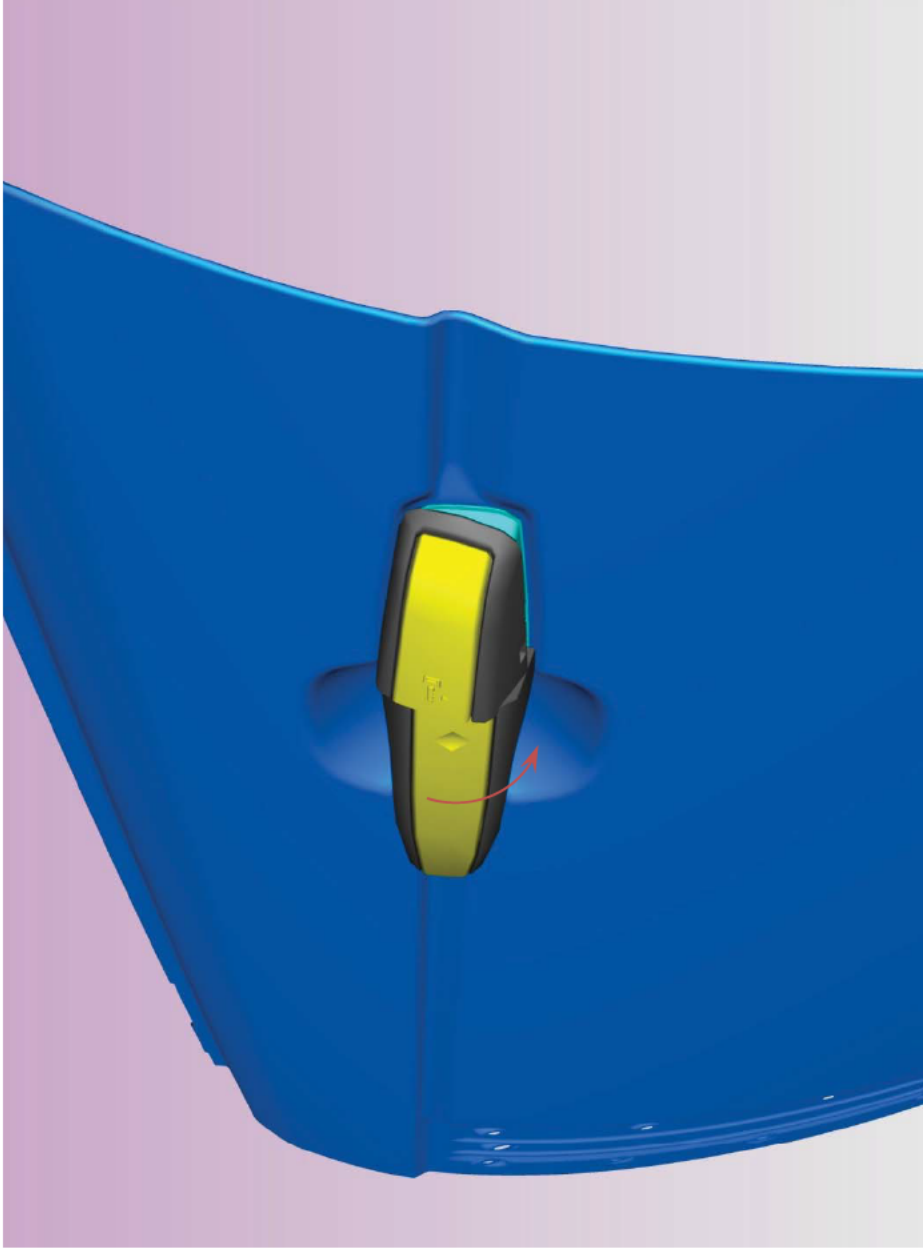

Located both of the clipping features into the gasket in a downwards motion. Once the upper retention lugs are located, rotated the Door Lock Cover downwards to engage the clip on the underside

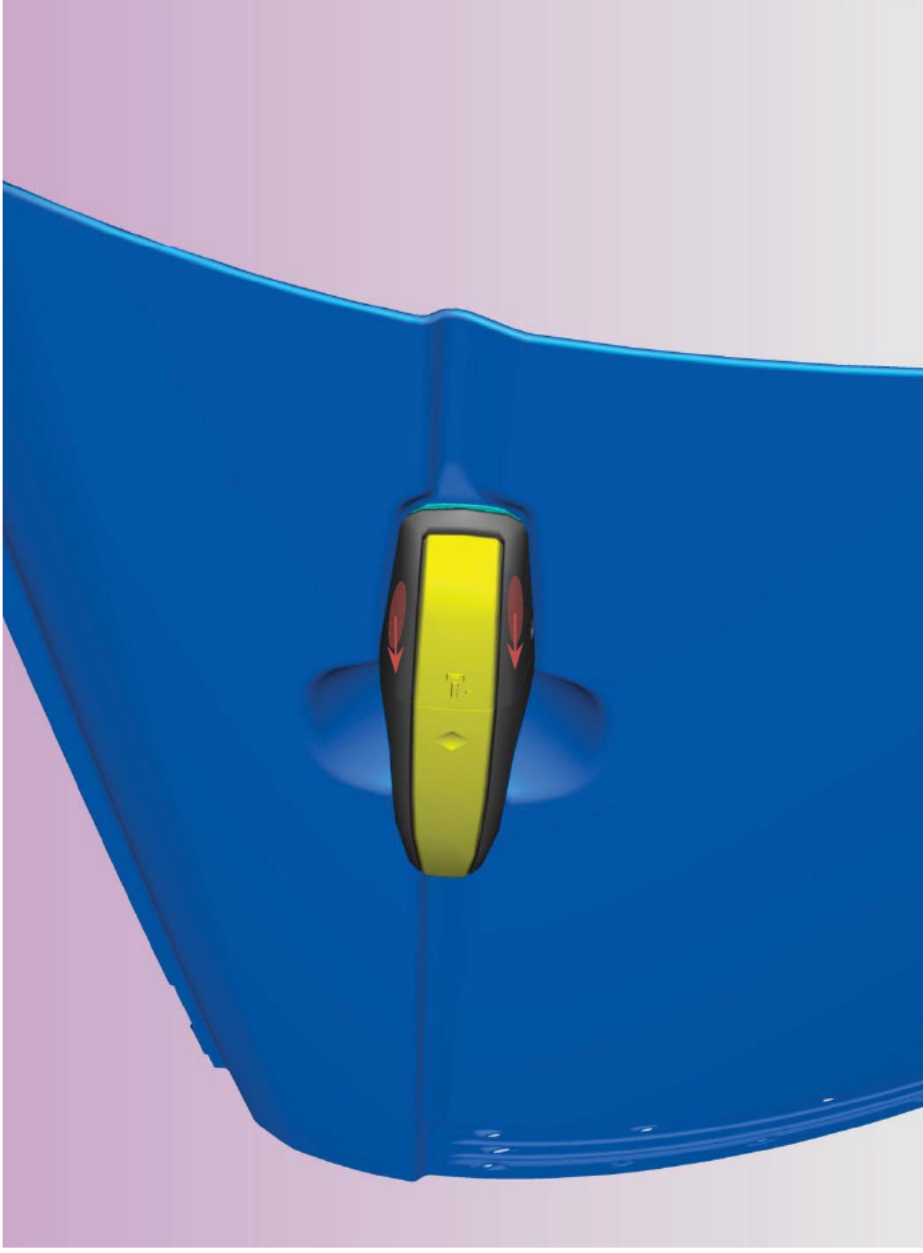

Rotate the Door Lock Cover downwards until a positive click is felt / heard, as the lower retention lug snaps into place in the gasket. Check the Door Lock Cover is secure by gently pulling it, it should remain securely in position on the vehicle.

Special Service Message

NOTE: A Special Service Message is a formal communication issued by Land Rover and carries the same importance of a Technical Service Bulletin. An SSM is a quick method of communicating "Need To Know" information to the technical service community. SSM's may be issued in advance of a technical bulletin or may be the only communication on a given topic. All information contained in Land Rover technical communications are intended for use by trained, professional technicians with the knowledge, tools, and equipment required to complete the procedure correctly and safely. It informs the Technicians of conditions that may occur on some vehicles, or provides information that could assist in correct vehicle and diagnostic service.

SSM 63857 - All New Range Rover Drivers Door Lock Covers not fitted correctly

Models : Range Rover / L405

Engineer : Adrian Pickard

Date Last 07-03-2013 07:16:15

Updated :

Content : **Concern**

A number of Dealers have reported that the Drivers Door Lock cover on the 'All New Range Rover' has either come adrift after fitment or has shown signs of cracking again after fitment by the Dealer

Action

It is important that the Dealer fit Driver's Door lock Cover is fitted correctly in order to prevent it coming adrift or cracking at a later date. Please refer to the attached file which details the fitting instructions.

Version : 2

Attachments 

Reference	SSM72130
Models	Range Rover / L405 Range Rover Sport / L494
Title	Range Rover (LG) and Range Rover Sport (LW) Side Door latch concern
Category	Body
Last modified	27-Feb-2015 00:00:00
Symptom	112000 Latches/Locks & Security
Attachments	11Latch codes.pdf (11Latch codes.pdf) 1Latch Part Numbers affected.pdf (1Latch Part Numbers affected.pdf) 1Paint Mark Location.pdf (1Paint Mark Location.pdf)

Content

Issue:
A customer may report that the side door latch is unable to retain the door in the closed position on their vehicle.

Cause:
Under investigation, updated SSM to replace only affected parts.

Action:
If your dealership lies within mainland UK (GBR), Germany (DEU), or the United Arab Emirates (ARE) please do not attempt to repair the vehicle. Raise a TA and retain the vehicle until your TA is responded to, provided it does not inconvenience the customer. If it will inconvenience the customer, take note of which door is failing to latch closed and only replace the affected latch on the vehicle. It is important that you use latches from a known supplier batch with a date code after 171214, or have a paintmark in the area indicated in the attachment. If the paintmark is present, the latch is ok to use with any date code. Do not use latches available at your dealership without the markings / date code highlighted in the attachment. New latches must be ordered from your Service Parts provider. Retain all the latches and be prepared to return them to Land Rover Engineering via the PRR process.

If your dealership does not lie within these regions, take note of which door is failing to latch closed and then replace only the affected latch on the vehicle with approved new parts as stated and report this action by submitting an EPQR.

Attached file lists the part numbers affected

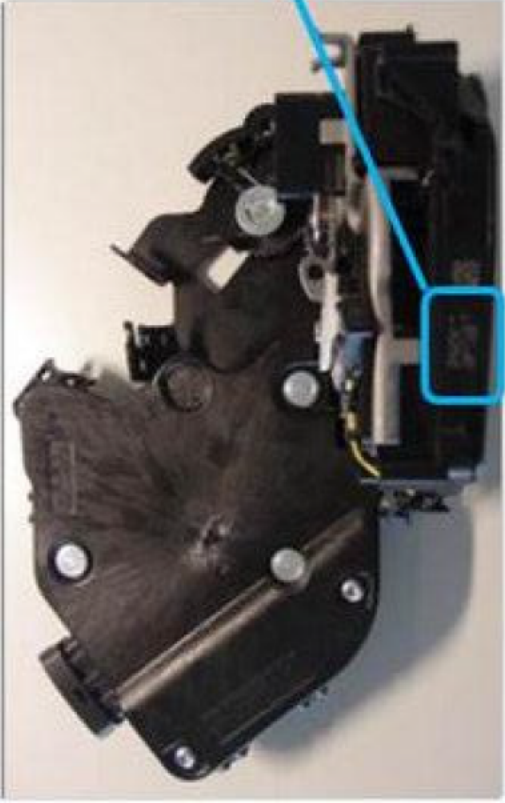

> 17th Dec 2014 (171214) OK

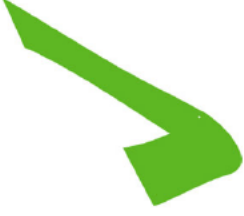

< (171214) NOK



Part Description

JLR Part Number

Land Rover Service Part Number

Front Right

LAT ASY FRT DR (DL PC PE)	CPLA-21812-AF	LR064791
LAT ASY FRT DR (DL PC PE)	CPLA-21812-AE	LR053668
LAT ASY FRT DR (DL PC PE)	CPLA-21812-AD	LR048233
LAT ASY FRT DR (DL PC PE)	CPLA-21812-AC	LR038389
LAT ASY FRT DR (CL PC PE)	CPLA-21812-BF	LR064792
LAT ASY FRT DR (CL PC PE)	CPLA-21812-BE	LR053669
LAT ASY FRT DR (CL PC PE)	CPLA-21812-BD	LR048234
LAT ASY FRT DR (CL PC PE)	CPLA-21812-BC	LR038393
LAT ASY FRT DR (DL PE)	CPLA-21812-EF	LR063627
LAT ASY FRT DR (DL PE)	CPLA-21812-EE	LR053670
LAT ASY FRT DR (DL PE)	CPLA-21812-ED	LR048235
LAT ASY FRT DR (DL PE)	CPLA-21812-EC	LR038407
LAT ASY FRT DR (CL PE)	CPLA-21812-FF	LR063609
LAT ASY FRT DR (CL PE)	CPLA-21812-FE	LR053671
LAT ASY FRT DR (CL PE)	CPLA-21812-FD	LR048236
LAT ASY FRT DR (CL PE)	CPLA-21812-FC	LR038409
LAT ASY FRT DR (DL PC PE LB)	CPLA-21812-JF	LR064793
LAT ASY FRT DR (DL PC PE LB)	CPLA-21812-JE	LR053674
LAT ASY FRT DR (DL PC PE LB)	CPLA-21812-JD	LR048239
LAT ASY FRT DR (DL PC PE LB)	CPLA-21812-JC	LR038415
LAT ASY FRT DR (CL PC PE LB)	CPLA-21812-KF	LR064794
LAT ASY FRT DR (CL PC PE LB)	CPLA-21812-KE	LR053675
LAT ASY FRT DR (CL PC PE LB)	CPLA-21812-KD	LR048240
LAT ASY FRT DR (CL PC PE LB)	CPLA-21812-KC	LR038419
LAT ASY FRT DR (DL PE LB)	CPLA-21812-NF	LR063617
LAT ASY FRT DR (DL PE LB)	CPLA-21812-NE	LR053676
LAT ASY FRT DR (DL PE LB)	CPLA-21812-ND	LR048241
LAT ASY FRT DR (DL PE LB)	CPLA-21812-NC	LR038421
LAT ASY FRT DR (CL PE LB)	CPLA-21812-PF	LR064795
LAT ASY FRT DR (CL PE LB)	CPLA-21812-PE	LR053677
LAT ASY FRT DR (CL PE LB)	CPLA-21812-PD	LR048242
LAT ASY FRT DR (CL PE LB)	CPLA-21812-PC	LR038424

Front Left

LAT ASY FRT DR (DL PC PE LB)	CPLA-21813-AF	LR064797
LAT ASY FRT DR (DL PC PE LB)	CPLA-21813-AE	LR053681
LAT ASY FRT DR (DL PC PE LB)	CPLA-21813-AD	LR048245
LAT ASY FRT DR (DL PC PE LB)	CPLA-21813-AC	LR039012
LAT ASY FRT DR (CL PC PE LB)	CPLA-21813-BF	LR064798
LAT ASY FRT DR (CL PC PE LB)	CPLA-21813-BE	LR053683
LAT ASY FRT DR (CL PC PE LB)	CPLA-21813-BD	LR048246
LAT ASY FRT DR (CL PC PE LB)	CPLA-21813-BC	LR039013
LAT ASY FRT DR (DL PE LB)	CPLA-21813-EF	LR063610
LAT ASY FRT DR (DL PE LB)	CPLA-21813-EE	LR053684
LAT ASY FRT DR (DL PE LB)	CPLA-21813-ED	LR048247
LAT ASY FRT DR (DL PE LB)	CPLA-21813-EC	LR038435
LAT ASY FRT DR (CL PE LB)	CPLA-21813-FF	LR063615

	LAT ASY FRT DR (CL PE LB)	CPLA-21813-FE	LR053685
	LAT ASY FRT DR (CL PE LB)	CPLA-21813-FD	LR048248
	LAT ASY FRT DR (CL PE LB)	CPLA-21813-FC	LR038438
	LAT ASY FRT DR (DL PC PE)	CPLA-21813-JF	LR064799
	LAT ASY FRT DR (DL PC PE)	CPLA-21813-JE	LR053688
	LAT ASY FRT DR (DL PC PE)	CPLA-21813-JD	LR048251
	LAT ASY FRT DR (DL PC PE)	CPLA-21813-JC	LR038445
	LAT ASY FRT DR (CL PC PE)	CPLA-21813-KF	LR064800
	LAT ASY FRT DR (CL PC PE)	CPLA-21813-KE	LR053689
	LAT ASY FRT DR (CL PC PE)	CPLA-21813-KD	LR048252
	LAT ASY FRT DR (CL PC PE)	CPLA-21813-KC	LR038447
	LAT ASY FRT DR (DL PE)	CPLA-21813-NF	LR063618
	LAT ASY FRT DR (DL PE)	CPLA-21813-NE	LR053690
	LAT ASY FRT DR (DL PE)	CPLA-21813-ND	LR048253
	LAT ASY FRT DR (DL PE)	CPLA-21813-NC	LR038451
	LAT ASY FRT DR (CL PE)	CPLA-21813-PF	LR064801
	LAT ASY FRT DR (CL PE)	CPLA-21813-PE	LR053691
	LAT ASY FRT DR (CL PE)	CPLA-21813-PD	LR048254
	LAT ASY FRT DR (CL PE)	CPLA-21813-PC	LR038454
Rear Right	LAT ASY RR DR (DL PC PE)	CPLA-26412-AF	LR064803
	LAT ASY RR DR (DL PC PE)	CPLA-26412-AE	LR053694
	LAT ASY RR DR (DL PC PE)	CPLA-26412-AD	LR048257
	LAT ASY RR DR (DL PC PE)	CPLA-26412-AC	LR038297
	LAT ASY RR DR (CL PC PE)	CPLA-26412-BF	LR064804
	LAT ASY RR DR (CL PC PE)	CPLA-26412-BE	LR053696
	LAT ASY RR DR (CL PC PE)	CPLA-26412-BD	LR048258
	LAT ASY RR DR (CL PC PE)	CPLA-26412-BC	LR038356
	LAT ASY RR DR (DL PE)	CPLA-26412-EF	LR063608
	LAT ASY RR DR (DL PE)	CPLA-26412-EE	LR053697
	LAT ASY RR DR (DL PE)	CPLA-26412-ED	LR048259
	LAT ASY RR DR (DL PE)	CPLA-26412-EC	LR038361
	LAT ASY RR DR (CL PE)	CPLA-26412-FF	LR063628
	LAT ASY RR DR (CL PE)	CPLA-26412-FE	LR053698
	LAT ASY RR DR (CL PE)	CPLA-26412-FD	LR048260
	LAT ASY RR DR (CL PE)	CPLA-26412-FC	LR038364
Rear Left	LAT ASY RR DR (DL PC PE)	CPLA-26413-AF	LR064805
	LAT ASY RR DR (DL PC PE)	CPLA-26413-AE	LR053703
	LAT ASY RR DR (DL PC PE)	CPLA-26413-AD	LR048263
	LAT ASY RR DR (DL PC PE)	CPLA-26413-AC	LR038372
	LAT ASY RR DR (CL PC PE)	CPLA-26413-BF	LR064806
	LAT ASY RR DR (CL PC PE)	CPLA-26413-BE	LR053704
	LAT ASY RR DR (CL PC PE)	CPLA-26413-BD	LR048264
	LAT ASY RR DR (CL PC PE)	CPLA-26413-BC	LR038374
	LAT ASY RR DR (DL PE)	CPLA-26413-EF	LR063622
	LAT ASY RR DR (DL PE)	CPLA-26413-EE	LR053706
	LAT ASY RR DR (DL PE)	CPLA-26413-ED	LR048265
	LAT ASY RR DR (DL PE)	CPLA-26413-EC	LR039086

LAT ASY RR DR (CL PE)	CPLA-26413-FF	LR063611
LAT ASY RR DR (CL PE)	CPLA-26413-FE	LR053707
LAT ASY RR DR (CL PE)	CPLA-26413-FD	LR048266
LAT ASY RR DR (CL PE)	CPLA-26413-FC	LR038380



Special Service Message

NOTE: A Special Service Message is a formal communication issued by Land Rover and carries the same importance of a Technical Service Bulletin. An SSM is a quick method of communicating "Need To Know" information to the technical service community. SSM's may be issued in advance of a technical bulletin or may be the only communication on a given topic. All information contained in Land Rover technical communications are intended for use by trained, professional technicians with the knowledge, tools, and equipment required to complete the procedure correctly and safely. It informs the Technicians of conditions that may occur on some vehicles, or provides information that could assist in correct vehicle and diagnostic service.

SSM 72241 - Exterior door handle keyless sensor inop

Models : Evoque / L538

Range Rover / L405

Engineer : Gary Payne

Date Last : 13-04-2015 09:10:37

Updated :

Content : Issue:

Exterior door handle keyless locking sensor does not operate when touched.

Cause:

Quality issue with the exterior door handle sensor.

Action:

Parts currently available have been modified to the latest condition,

If a vehicle is presented with the issue detailed above complete the normal diagnostics using SDD. If the keyless locking sensor is identified as the root cause, replace the door handle assembly

Assured VIN's as follows:-

Range Rover (L405) – LG167709

Evoque (L538) – LV955423

JLR engineering would like to thank everyone who submitted EPQR's highlighting and assisting this investigation. Please only submit further EPQR's for vehicles manufactured after the assured VIN's provided above

Version : 2

Special Service Message

NOTE: A Special Service Message is a formal communication issued by Land Rover and carries the same importance of a Technical Service Bulletin. An SSM is a quick method of communicating "Need To Know" information to the technical service community. SSM's may be issued in advance of a technical bulletin or may be the only communication on a given topic. All information contained in Land Rover technical communications are intended for use by trained, professional technicians with the knowledge, tools, and equipment required to complete the procedure correctly and safely. It informs the Technicians of conditions that may occur on some vehicles, or provides information that could assist in correct vehicle and diagnostic service.

SSM 72333 - Rear Doors Not Locking or Front Seats Inoperative

Models : Range Rover / L405

Engineer :Richard Attwood

Date Last 01-10-2015 15:44:56

Updated :

Content : **Issue:** A customer may report any of the following vehicle symptoms:

1. Intermittently the rear doors do not lock when the remote plip button is pressed.
2. Drivers seat switchpack inoperative
3. Rear doors show open on the Instrument Cluster when they are fully closed.
4. Remote central locking inoperative.
5. Window switchpack inoperative.
6. Interior compartment lights illuminated, when not required.
7. Rear doors make locking sound while driving.
8. Rear door soft close function inoperative.
9. Deployable side steps fail to retract.

Cause: Possible poor earth connection at ground point G3D375 (See attachment).

Action: If any of the above concerns have been reported by the customer, check ground point G3D375 for continuity and security of fastener. If the ground point is not the cause of the concern, then continue with diagnostics using Symptom Driven Diagnostics and with reference to TOPIx Workshop Manual.

Version : 4

Attachments : 

Special Service Message

NOTE: A Special Service Message is a formal communication issued by Land Rover and carries the same importance of a Technical Service Bulletin. An SSM is a quick method of communicating "Need To Know" information to the technical service community. SSM's may be issued in advance of a technical bulletin or may be the only communication on a given topic. All information contained in Land Rover technical communications are intended for use by trained, professional technicians with the knowledge, tools, and equipment required to complete the procedure correctly and safely. It informs the Technicians of conditions that may occur on some vehicles, or provides information that could assist in correct vehicle and diagnostic service.

SSM 72721 - Unilatch (Door) latch system diagnosis procedure

Models : Discovery Sport / L550
Range Rover / L405
Range Rover Sport / L494

Engineer : Ian Cavanagh

Date Last : 30-06-2016 12:31:11

Updated :

Content : Issue: Door latches are being replaced when a customer reports issues with the locking or latching function on one or more doors on their vehicle.

Cause: The correct diagnosis procedure is not being followed.

Action: Please perform the following diagnosis within TOPIx for Unilatch door systems:

TOPIx Workshop Manual

5: Body Paint

501: Body and Paint

501-14: Handles, Locks, Latches and Entry systems - Diagnosis and Testing (Lock's Latches and Entry Systems).

Version : 3

Reference	SSM73972
------------------	----------

Models	Discovery / L462 Discovery Sport / L550 Range Rover / L405 Range Rover Sport / L494 Range Rover Velar / L560
---------------	--

Title	Land Rover Door Latch Issues - Contamination with Silicon
--------------	---

Category	Body
-----------------	------

Last modified	24-Jul-2018 00:00:00
----------------------	----------------------

Symptom	112000 Latches/Locks & Security
----------------	---------------------------------

Content	<p><u>Issue:</u> Customers are reporting that side door latches do not operate correctly. Symptoms include latches that will not lock / will not unlock / will not open.</p> <p><u>Cause:</u> Migration of silicon based oils through the latch and onto the internal latch electric motors.</p> <p><u>Action:</u> Under no circumstances should silicon based grease or oils be applied to door latches.</p> <p>Technicians - Please rate this SSM and provide comments so that future communications can be improved.</p> <p>1 = Poor – Basic information provided – The SSM does not help me resolve the customer concern.</p> <p>3 = Average – Adequate information provided – The SSM partially helps me resolve the customer concern.</p> <p>5 = Excellent – All required information provided to resolve the customer concern.</p>
----------------	--