

Spell Check

CAC SR Data Share (Data Entry Page)

Clear Form

Customer's first name:	[REDACTED]
Customer's last name:	[REDACTED]
Customer's 1st choice phone#:	[REDACTED]
Alternate phone#:	n/a
Best time to contact the customer:	n/a
Description of the customer's concern, request, expectations:	The customer is seeking to have issue with headlights resolved. The customer states that recent repair was done with relay and that it didn't resolve issue. The customer is seeking to get the vehicle in and have concern resolved and is hoping no cost due to info on internet. The customer states that he is avaiab/ as early as after 2pm today(1/2/14)
Current status of the vehicle concern (described above)?	Unresolved - Customer has a current vehicle concern
Current status of vehicle diagnosis (for concern described)?	Not yet diagnosed
Current status of the vehicle repairs (for concern described)?	Repairs have not been scheduled
How many times has vehicle been in for service (for concern described)?	0
<i>(if the vehicle has been serviced for this concern previously)</i> Details regarding previous trips to service:	
Was the vehicle ever inoperable/down as a result of concern described?	Yes - Vehicle was inop/down for this concern
<i>(if the vehicle was ever inop/down for this concern)</i> How many days down?	0
Current status of the vehicle (operable or inoperable)?	Vehicle is operable (vehicle is being driven)
Has customer spent money out-of-pocket as a result of this concern?	No
<i>(if there are out-of-pocket expenses)</i> Provide the details:	

At this point let the customer know: To better assist them, you need to gather some additional information from them....

Is this the original vehicle owner?	No - Customer bought used
<i>(if bought used)</i> When was the vehicle purchased?	
<i>(if bought used)</i> How many miles were on the vehicle at time of purchase?	Unknown
<i>(if bought used)</i> Was vehicle bought at a GM Dealership?	N/A (Not purchased used)
What is the current mileage on the vehicle (estimate is fine)?	92,000
Is this the customer's first GM vehicle?	No

Any other key points from the customer (notes):	
---	--

**End conversation with the customer here. --> Complete the rest of the SR Data Share on your own (without the customer on the phone).**

CAC Case type (categorized):	Customer has a current vehicle operation concern (did NOT explicitly request cost assistance)
Today's date:	01/02/14
Service Request (SR) #:	[REDACTED]
Is this a reopened SR (SR was reopened for same VIN, same concern)?	No - This is a new SR
<i>(If this is a reopened SR)</i> What is the customer's reason for calling back (reopening the concern)?	
<i>(If reopened for some other reason)</i> What was the other reason?	
CAC Tier 2 Agent's first name:	Shanette
CAC Tier 2 Agent's last name:	Rose
CAC Tier 2 Agent's phone #:	(866) 790-5600
CAC Tier 2 Agent's phone extension #:	31405
BAC#:	132958
Involved dealer:	Coulter Motor Company, L.L.C.
Involved dealer phone #:	(480) 735-2399
CCS's first name:	[REDACTED]
CCS's preferred method of contact:	Phone
CCS's phone #:	[REDACTED]
CCS's email address:	[REDACTED]
VIN#:	2G4WD58286 [REDACTED] 5
Make:	Chevrolet
Model:	LaCrosse
Year:	2006
Is this a discontinued brand vehicle?	No
Is this a premium vehicle?	No
Has this customer owned non-GM vehicles? (conquest buyer)	Unknown - Customer did not provide this info
Total # of Required Field Actions listed for this VIN:	0
<i>(if there are any Required Field Actions listed)</i> How many are <b>still open</b> :	0
Total # of Special Coverage items listed for this VIN:	0
<i>(If customer bought used)</i> Is this a GM Certified Pre-owned used vehicle?	No
Does the vehicle have any Service Contracts?	No - This VIN has no service contracts
<b>(Validated data)</b> Total # of GM vehicles this customer has owned? (including the one customer is calling about) (also including vehicles purchased under a maiden/spouse name)  <i>(NOTE) Copy &amp; paste the list of GM vehicles owned in the cell below (B58)</i>	

# CAC SR Data Share (Report)

SR=Service Request

Report date: **01/02/14**

File version#/date: 10-29-13, v 1.0

## CAC Case Information:

Siebel Service Request (SR) #:	[REDACTED]
Is this a reopened SR (same VIN#, same concern)?	No - This is a new SR
<i>(if reopened)</i> Customer's reason for calling back (reopening)?	0
<b>(Validated)</b> Has goodwill / cost assistance been applied to this VIN?	0
<i>(if goodwill/cost assistance has been applied to VIN)</i> Details:	0
CAC Tier 2 (T2) Agent's name:	Shanette Rose
CAC agent's phone #:	(866) 790-5600
CAC T2 Agent's Extension#:	31405
Involved dealer:	Coulter Motor Company, L.L.C.
BAC#:	132958
Involved dealer's phone #:	(480) 735-2399
CCS's name:	[REDACTED]
CCS's phone #:	[REDACTED] 0
CCS's email address:	[REDACTED]
CCS's preferred method of contact:	Phone

## Customer Information:

Customer's [REDACTED]	[REDACTED]
Customer's phone#:	[REDACTED]
Customer's alternate phone#:	n/a
Best time to contact the customer:	n/a

## Vehicle Information:

VIN#:	2G4WD5828611 [REDACTED]
MY/Make/Model:	2006 Chevrolet LaCrosse
Original vehicle owner?:	No - Customer bought used
Is this a GM Certified Pre-owned vehicle?	No
<i>(if bought used)</i> Purchase date:	Jan-1900
<i>(if bought used)</i> Estimated mileage at time of purchase:	Unknown
Current mileage:	92,000
Total # of Special Coverage items listed (regardless of relevance):	0 Special Coverages
Are there Service Contracts for this vehicle? (regardless of relevance):	No - This VIN has no service contracts

## Description of the customer's concern, request, expectations:

The customer is seeking to have issue with headlights resolved. The customer states that recent repair was done with relay and that it didn't resolve issue. The customer is seeking to get the vehicle in and have concern resolved and is hoping no cost due to info on internet. The customer states that he is avaiab/ as early as after 2pm today(1/2/14)

## Any other key points made by the customer (notes):

0

## CAC Case type (categorized):

Customer has a current vehicle operation concern (did NOT explicitly request cost assistance)

## Current Status of the Vehicle (for the concern described):

Status of the original vehicle concern:	Unresolved - Customer has a current vehicle concern
Vehicle operation:	Vehicle is operable (vehicle is being driven)
Diagnosis:	Not yet diagnosed

Repairs: Repairs have not been scheduled

**Customer Inconvenience (for the concern described):**

# of times in for service (per customer):	0 time(s) in for this same concern
Details regarding previous service trips (per the customer):	0
Vehicle ever inop/down due to concern described (per the customer):	Yes - Vehicle was inop/down for this concern
How many days vehicle inop/down (per customer):	0 days
Has customer spent money out-of-pocket for concern described?	No
Details regarding any out-of-pocket expenses:	0
<b>(Validated)</b> # of Required Field Actions listed for this VIN:	0 Field Actions
<b>(Validated)</b> # of open Required Field Actions:	0 still open

**Customer Loyalty:**

Is this a discontinued brand vehicle?	No
Is this a premium vehicle?	No
Is this a conquest customer (has owned non-GM vehicles)?	Unknown - Customer did not provide this info
Is this the customer's first GM vehicle?	No
<b>(Validated)*</b> Customer has owned this # of GM vehicles:	0
<b>(Validated)*</b> List of GM vehicles owned by this customer:	0

\*Limited: Customer may not have provided maiden/spouse names

**Version #/date**

Pilot, 10-16-13

Pilot, 10-17-13

Pilot, 10-18-13

Pilot, 10-18-13 (2)

Draft, 10-21-13

Draft, 10-22-13

Draft, 10-23-13

Draft, 10-24-13

Draft, 10-25-13

Draft, 10-28-13 (AM)

Draft, 10-28-13 (PM)

10-29-13, v 1.0

## **Comments**

Pilot file (T2 Austin & T2 Warren)

Shoy's team in Warren found a problem! Fixed it.

Wording changes to clarify CAC case categorization choices, Added line item to call out conquest customer

Added place for CCS's phone # & email address b/c the agent is going to need it once they're ready to send this to

Changes made in response to feedback from Austin & the Field (RSM's & CAM's)

Changes per pilot group feedback

Changes per TL Training session & pilot group feedback

Home, Format, Auto Row Height & Protected Workbook

Reworded reopened list dropdown, minor corrections, added other key points section to the report tab

MCE 1.0 Launch file -- Chris Burger added reset, autofit macros

Added N/A's to several dropdowns per pilot feedback & moved other key points up into new spot in the report; G

Final edits per pre-Launch training session feedback

Looking forward, can we just spellcheck the free text cells?

the CCS. Made B4 bigger. Changed color of B4.

ot rid of the merged cells on the data entry tab

Spell Check

## CAC SR Data Share (Data Entry Page)

Clear Form

Customer's first name:	[REDACTED]
Customer's last name:	[REDACTED]
Customer's 1st choice phone#:	[REDACTED] 9
Alternate phone#:	
Best time to contact the customer:	Anytime
<b>Description of the customer's concern, request, expectations:</b>	Customer sts: -Veh is having an issue with the headlights going off which is having an issue especially at night -Customer took the veh in and the issue was not present and therefore the dlr could not properly diagnose the issue  Customer sks to have if there is another way repairs can be performed and the vehicle can be diagnosed
Current status of the vehicle concern (described above)?	Unresolved - Customer has a current vehicle concern
Current status of vehicle diagnosis (for concern described)?	Not yet diagnosed
Current status of the vehicle repairs (for concern described)?	Repairs have not been scheduled
How many times has vehicle been in for service (for concern described)?	2
<i>(if the vehicle has been serviced for this concern previously)</i> Details regarding previous trips to service:	
Was the vehicle ever inoperable/down as a result of concern described?	No
<i>(if the vehicle was ever inop/down for this concern)</i> How many days down?	N/A
Current status of the vehicle (operable or inoperable)?	Vehicle is operable (vehicle is being driven)
Has customer spent money out-of-pocket as a result of this concern?	Yes - Customer spent money out-of-pocket as a result of this concern
<i>(if there are out-of-pocket expenses)</i> Provide the details:	Diagnostic Test
<b>At this point let the customer know: To better assist them, you need to gather some additional information from them....</b>	
Is this the original vehicle owner?	Yes - Customer bought vehicle brand new
<i>(if bought used)</i> When was the vehicle purchased?	Mar-2007
<i>(if bought used)</i> How many miles were on the vehicle at time of purchase?	20
<i>(if bought used)</i> Was vehicle bought at a GM Dealership?	Yes - Bought used at a GM Dealership
What is the current mileage on the vehicle (estimate is fine)?	72,000
Is this the customer's first GM vehicle?	No

Any other key points from the customer (notes):	
---	--

**End conversation with the customer here. --> Complete the rest of the SR Data Share on your own (without the customer on the phone).**

CAC Case type (categorized):	Customer has a current vehicle operation concern (did NOT explicitly request cost assistance)
Today's date:	05/21/14
Service Request (SR) #:	██████████
Is this a reopened SR (SR was reopened for same VIN, same concern)?	No - This is a new SR
<b>(If this is a reopened SR)</b> What is the customer's reason for calling back (reopening the concern)?	N/A (Not a reopened case)
<b>(If reopened for some other reason)</b> What was the other reason?	N/A
CAC Tier 2 Agent's first name:	Asia
CAC Tier 2 Agent's last name:	Philpot
CAC Tier 2 Agent's phone #:	(866) 790-5700
CAC Tier 2 Agent's phone extension #:	21760
BAC#:	278140
Involved dealer:	Gordon Automotive LLC.
Primary Customer Experience Manager's first & last name:	Jeff Haze
Primary CE Manager's preferred contact method:	Email
Primary CE Manager's (office) phone # :	215-537-2377
Primary CE Manager's cell phone #:	
Primary CE Manager's email address:	jhaze@gordonchevroletpa.com
VIN#:	1GNDT13S3722 ██████████
Make:	Chevrolet
Model:	TrailBlazer
Year:	2007
Is this a discontinued brand vehicle?	No
Is this a premium vehicle?	No
Has this customer owned non-GM vehicles? (conquest buyer)	Unknown - Customer did not provide this info
Total # of Required Field Actions listed for this VIN:	1
<b>(if there are any Required Field Actions listed)</b> How many are <b>still open</b> :	0
Total # of Special Coverage items listed for this VIN:	1
<b>(If customer bought used)</b> Is this a GM Certified Pre-owned used vehicle?	N/A (Not purchased used)
Does the vehicle have any Service Contracts?	No - This VIN has no service contracts
<b>(Validated data)</b> Total # of GM vehicles this customer has owned? (including the one customer is calling about) (also including vehicles purchased under a maiden/spouse name)  <i>NOTE) Copy &amp; paste the list of GM vehicles owned in the cell below (B58)</i>	4

# CAC SR Data Share (Report)

SR=Service Request

Report date: **05/21/14**

File version#/date: 2-3-14, v 2

## CAC Case Information:

Siebel Service Request (SR) #:	[REDACTED]
Is this a reopened SR (same VIN#, same concern)?	No - This is a new SR
<i>(if reopened)</i> Customer's reason for calling back (reopening)?	N/A (Not a reopened case)
<b>(Validated)</b> Has goodwill / cost assistance been applied to this VIN?	No
<i>(if goodwill/cost assistance has been applied to VIN)</i> Details:	N/A
CAC Tier 2 (T2) Agent's name:	Asia Philpot
CAC agent's phone #:	(866) 790-5700
CAC T2 Agent's Extension#:	21760
Involved dealer:	Gordon Automotive Llc.
BAC#:	278140
Primary Customer Experience Manager's name:	Jeff Haze
Primary CE Manager's preferred method of contact:	Email
Primary CE Manager's (office) phone #:	215-537-2377
Primary CE Manager's cell phone#:	-
Primary CE Manager's email address:	jhaze@gordonchevroletpa.com

## Customer Information:

Customer's name:	[REDACTED]
Customer's phone#:	[REDACTED]
Customer's alternate phone#:	-
Best time to contact the customer:	Anytime

## Vehicle Information:

VIN#:	1GNDT13S372 [REDACTED]
MY/Make/Model:	2007 Chevrolet TrailBlazer
Original vehicle owner?:	Yes - Customer bought vehicle brand new
Is this a GM Certified Pre-owned vehicle?	N/A (Not purchased used)
<i>(if bought used)</i> Purchase date:	Mar-2007
<i>(if bought used)</i> Estimated mileage at time of purchase:	20
Current mileage:	72,000
Total # of Special Coverage items listed (regardless of relevance):	1 Special Coverages
Are there Service Contracts for this vehicle? (regardless of relevance):	No - This VIN has no service contracts

## Description of the customer's concern, request, expectations:

Customer sts:  
 -Veh is having an issue with the headlights going off which is having an issue especially at night  
 -Customer took the veh in and the issue was not present and therefore the dlr could not properly diagnose the issue  
  
 Customer sks to have if there is another way repairs can be performed and the vehicle can be diagnosed

## Any other key points made by the customer (notes):

0

## CAC Case type (categorized):

Customer has a current vehicle operation concern (did NOT explicitly request cost assistance)

## Current Status of the Vehicle (for the concern described):

Status of the original vehicle concern:	Unresolved - Customer has a current vehicle concern
Vehicle operation:	Vehicle is operable (vehicle is being driven)
Diagnosis:	Not yet diagnosed
Repairs:	Repairs have not been scheduled

**Customer Inconvenience (for the concern described):**

# of times in for service (per customer):	2 time(s) in for this same concern
Details regarding previous service trips (per the customer):	0
Vehicle ever inop/down due to concern described (per the customer):	No
How many days vehicle inop/down (per customer):	N/A days
Has customer spent money out-of-pocket for concern described?	Yes - Customer spent money out-of-pocket as a result of this concern
Details regarding any out-of-pocket expenses:	Diagnostic Test
<b>(Validated)</b> # of Required Field Actions listed for this VIN:	1 Field Actions
<b>(Validated)</b> # of open Required Field Actions:	0 still open

**Customer Loyalty:**

Is this a discontinued brand vehicle?	No
Is this a premium vehicle?	No
Is this a conquest customer (has owned non-GM vehicles)?	Unknown - Customer did not provide this info
Is this the customer's first GM vehicle?	No
<b>(Validated)*</b> Customer has owned this # of GM vehicles:	4
<b>(Validated)*</b> List of GM vehicles owned by this customer:	2007 CHEVROLET TRAILBLAZER 2005 CHEVROLET TRAILBLAZER 2002 CHEVROLET CAVALIER

\*Limited: Customer may not have provided maiden/spouse names

**Version #/date**

Pilot, 10-16-13

Pilot, 10-17-13

Pilot, 10-18-13

Pilot, 10-18-13 (2)

Draft, 10-21-13

Draft, 10-22-13

Draft, 10-23-13

Draft, 10-24-13

Draft, 10-25-13

Draft, 10-28-13 (AM)

Draft, 10-28-13 (PM)

10-29-13, v 1.0

2-3-14, v 2

## **Comments**

Pilot file (T2 Austin & T2 Warren)

Shoy's team in Warren found a problem! Fixed it.

Wording changes to clarify CAC case categorization choices, Added line item to call out conquest customer

Added place for CCS's phone # & email address b/c the agent is going to need it once they're ready to send this to

Changes made in response to feedback from Austin & the Field (RSM's & CAM's)

Changes per pilot group feedback

Changes per TL Training session & pilot group feedback

Home, Format, Auto Row Height & Protected Workbook

Reworded reopened list dropdown, minor corrections, added other key points section to the report tab

MCE 1.0 Launch file -- Chris Burger added reset, autofit macros

Added N/A's to several dropdowns per pilot feedback & moved other key points up into new spot in the report; G

Final edits per pre-Launch training session feedback

Changes made to make this file match new BAC Lookup tab in CE Mgr Lookup, Replaced CCS w/ CE Mgr, Add hint

the CCS. Made B4 bigger. Changed color of B4.

ot rid of the merged cells on the data entry tab

on how to paste special as a value

Spell Check

CAC SR Data Share (Data Entry Page)

Clear Form

Customer's first name	[REDACTED]
Customer's last name	[REDACTED]
Customer's 1st choice phone#:	[REDACTED]
Alternate phone#:	
Best time to contact the customer:	Anytime
<b>Description of the customer's concern, request, expectations:</b>	Customer opened file with us in regards to a headlight concern customer did not have Vin on hand but did advised has had his vehicle into dealership and they were unable to duplicate vehicles concern is the low beams turning off and on by themselves. At this time we are needing bring the vehicle back in.
Current status of the vehicle concern (described above)?	Unresolved - Customer has a current vehicle concern
Current status of vehicle diagnosis (for concern described)?	Diagnosed
Current status of the vehicle repairs (for concern described)?	Repairs have not been scheduled
How many times has vehicle been in for service (for concern described)?	1
<i>(if the vehicle has been serviced for this concern previously)</i> Details regarding previous trips to service:	
Was the vehicle ever inoperable/down as a result of concern described?	No
<i>(if the vehicle was ever inop/down for this concern)</i> How many days down?	
Current status of the vehicle (operable or inoperable)?	Vehicle is operable (vehicle is being driven)
Has customer spent money out-of-pocket as a result of this concern?	No
<i>(if there are out-of-pocket expenses)</i> Provide the details:	

**At this point let the customer know: To better assist them, you need to gather some additional information from them....**

Is this the original vehicle owner?	Yes - Customer bought vehicle brand new
<i>(if bought used)</i> When was the vehicle purchased?	
<i>(if bought used)</i> How many miles were on the vehicle at time of purchase?	
<i>(if bought used)</i> Was vehicle bought at a GM Dealership?	N/A (Not purchased used)
What is the current mileage on the vehicle (estimate is fine)?	75,000
Is this the customer's first GM vehicle?	No

Any other key points from the customer (notes):	
---	--

**End conversation with the customer here. --> Complete the rest of the SR Data Share on your own (without the customer on the phone).**

CAC Case type (categorized):	Customer has a current vehicle operation concern (did NOT explicitly request cost assistance)
Today's date:	06/09/14
Service Request (SR) #:	7 [REDACTED]
Is this a reopened SR (SR was reopened for same VIN, same concern)?	No - This is a new SR
<b>(If this is a reopened SR)</b> What is the customer's reason for calling back (reopening the concern)?	N/A (Not a reopened case)
<b>(If reopened for some other reason)</b> What was the other reason?	n/a
CAC Tier 2 Agent's first name:	Valerie
CAC Tier 2 Agent's last name:	Alvarado
CAC Tier 2 Agent's phone #:	(866) 790-5700
CAC Tier 2 Agent's phone extension #:	21386
BAC#:	112151
Involved dealer:	Gold Rush Chevrolet Inc.
Involved dealer phone #:	(530) 885-0471
CCS's first name:	Roger
CCS's last name:	Fong
CCS's preferred method of contact:	Email
CCS's phone #:	(530) 885-0471
CCS's email address:	rfong@goldrushchevy.com
VIN#:	2G1WF5EK6B1 [REDACTED]
Make:	Chevrolet
Model:	TrailBlazer
Year:	2009
Is this a discontinued brand vehicle?	No
Is this a premium vehicle?	No
Has this customer owned non-GM vehicles? (conquest buyer)	Unknown - Customer did not provide this info
Total # of Required Field Actions listed for this VIN:	0
<b>(if there are any Required Field Actions listed)</b> How many are <u>still open</u> :	N/A (There were no Required Field Actions for this VIN)
Total # of Special Coverage items listed for this VIN:	0
<b>(If customer bought used)</b> Is this a GM Certified Pre-owned used vehicle?	N/A (Not purchased used)
Does the vehicle have any Service Contracts?	No - This VIN has no service contracts
<b>(Validated data)</b> Total # of GM vehicles this customer has owned? (including the one customer is calling about) (also including vehicles purchased under a maiden/spouse name)  <i>NOTE) Copy &amp; paste the list of GM vehicles owned in the cell below (B58)</i>	

# CAC SR Data Share (Report)

SR=Service Request

Report date: **06/09/14**

File version#/date: 10-29-13, v 1.0

## CAC Case Information:

Siebel Service Request (SR)	[REDACTED]
Is this a reopened SR (same VIN#, same concern)? <i>(if reopened)</i> Customer's reason for calling back (reopening)?	No - This is a new SR N/A (Not a reopened case)
<b>(Validated)</b> Has goodwill / cost assistance been applied to this VIN? <i>(if goodwill/cost assistance has been applied to VIN)</i> Details:	0 n/a
CAC Tier 2 (T2) Agent's name:	Valerie Alvarado
CAC agent's phone #:	(866) 790-5700
CAC T2 Agent's Extension#:	21386
Involved dealer:	Gold Rush Chevrolet Inc.
BAC#:	112151
Involved dealer's phone #:	(530) 885-0471
CCS's name:	Roger Fong
CCS's phone #:	(530) 885-0471
CCS's email address:	rfong@goldrushchevy.com
CCS's preferred method of contact:	Email

## Customer Information:

Customer's name:	[REDACTED]
Customer's phone#:	[REDACTED]
Customer's alternate phone#:	-
Best time to contact the customer:	Anytime

## Vehicle Information:

VIN#:	2G1WF5EK6B12 [REDACTED]
MY/Make/Model:	2009 Chevrolet TrailBlazer
Original vehicle owner?:	Yes - Customer bought vehicle brand new
Is this a GM Certified Pre-owned vehicle? <i>(if bought used)</i> Purchase date:	N/A (Not purchased used) Jan-1900
<i>(if bought used)</i> Estimated mileage at time of purchase:	0
Current mileage:	75,000
Total # of Special Coverage items listed (regardless of relevance):	0 Special Coverages
Are there Service Contracts for this vehicle? (regardless of relevance):	No - This VIN has no service contracts

## Description of the customer's concern, request, expectations:

Customer opened file with us in regards to a headlight concern customer did not have Vin on hand but did advised has had his vehicle into dealership and they were unable to duplicate vehicles concern is the low beams turning off and on by themselves. At this time we are needing bring the vehicle back in.

## Any other key points made by the customer (notes):

0

## CAC Case type (categorized):

Customer has a current vehicle operation concern (did NOT explicitly request cost assistance)

## Current Status of the Vehicle (for the concern described):

Status of the original vehicle concern:	Unresolved - Customer has a current vehicle concern
Vehicle operation:	Vehicle is operable (vehicle is being driven)
Diagnosis:	Diagnosed
Repairs:	Repairs have not been scheduled

**Customer Inconvenience (for the concern described):**

# of times in for service (per customer):	1 time(s) in for this same concern
Details regarding previous service trips (per the customer):	0
Vehicle ever inop/down due to concern described (per the customer):	No
How many days vehicle inop/down (per customer):	days
Has customer spent money out-of-pocket for concern described?	No
Details regarding any out-of-pocket expenses:	0
<b>(Validated)</b> # of Required Field Actions listed for this VIN:	0 Field Actions
<b>(Validated)</b> # of open Required Field Actions:	N/A (There were no Required Field Actions for this VIN) still open

**Customer Loyalty:**

Is this a discontinued brand vehicle?	No
Is this a premium vehicle?	No
Is this a conquest customer (has owned non-GM vehicles)?	Unknown - Customer did not provide this info
Is this the customer's first GM vehicle?	No
<b>(Validated)*</b> Customer has owned this # of GM vehicles:	0
<b>(Validated)*</b> List of GM vehicles owned by this customer:	0

\*Limited: Customer may not have provided maiden/spouse names

**Version #/date**

Pilot, 10-16-13

Pilot, 10-17-13

Pilot, 10-18-13

Pilot, 10-18-13 (2)

Draft, 10-21-13

Draft, 10-22-13

Draft, 10-23-13

Draft, 10-24-13

Draft, 10-25-13

Draft, 10-28-13 (AM)

Draft, 10-28-13 (PM)

10-29-13, v 1.0

## **Comments**

Pilot file (T2 Austin & T2 Warren)

Shoy's team in Warren found a problem! Fixed it.

Wording changes to clarify CAC case categorization choices, Added line item to call out conquest customer

Added place for CCS's phone # & email address b/c the agent is going to need it once they're ready to send this to

Changes made in response to feedback from Austin & the Field (RSM's & CAM's)

Changes per pilot group feedback

Changes per TL Training session & pilot group feedback

Home, Format, Auto Row Height & Protected Workbook

Reworded reopened list dropdown, minor corrections, added other key points section to the report tab

MCE 1.0 Launch file -- Chris Burger added reset, autofit macros

Added N/A's to several dropdowns per pilot feedback & moved other key points up into new spot in the report; G

Final edits per pre-Launch training session feedback

Looking forward, can we just spellcheck the free text cells?

the CCS. Made B4 bigger. Changed color of B4.

ot rid of the merged cells on the data entry tab

Connecting...A live chat agent is now entering the chat.

Caller English

System:

Welcome to GMC

Connecting...A live chat agent is now entering the chat. [Angel]

System:

Welcome to chat.

Angel:

Good morning, [REDACTED] thank you for chatting with GMC. My name is Angel, and I'll be taking care of you today! May I ask what vehicle you are interested in?

[REDACTED]:

I HAVE A 2005ENVOY WITH PROBLEMS

[REDACTED]

HEADLIGHTS KEEP GOING OFF CAN SOMEONE HELP ME

Angel:

May I ask if you have spoken with your local GMC dealer about the headlights going on and off?

[REDACTED]:

YES NO ONE CAN FIND THE PROBLEM

Angel:

I'm sorry to hear that, [REDACTED].

Angel:

We thank you for bringing these concerns to our attention so that we may help you work towards a solution. As a Marketing Support Advisor, I am here to answer new vehicle product questions, however, our Customer Assistance Advisors are specifically trained to deal with vehicle issues like yours. If you don't mind, I'd like to transfer you to the Customer Assistance Center so GMC can properly assist you.

[REDACTED]:

THANK YOU

Connecting...A live chat agent is now entering the chat. [Stacy]

Agent Angel left the call

wendell:

HI

Stacy:

Thank you for contacting GM Customer Assistance. We here at Customer Service Center are not able, nor equipped to make any specific diagnosis on your vehicle. It is for this reason that we rely heavily on the service staff at your GM dealership to provide our customers with any type of mechanical diagnosis. Would you like me to locate another dealership on your behalf?

[REDACTED]

I HAVE TAKEN IT TO 4 DIFFERENT DEALERS NO ONE SEEMS TO BE ABLE TO FIND THE PROBLEM EXCEPY THAT THEY TELL ME ITS IN THE ELECTRICAL SYSTEM

[REDACTED]

I ALREADY NO MTHAT

Stacy:

I understand. However, we are not technically trained so I wouldn't be able to advise you on what the issue is. What it sounds like is that the dealership needs to contact their technical team at GM for assistance if they are not able to locate the exact cause of the issue.

wendell:

ARE THERE ANY RECALLS ON THE ELECTRIC SYSTEM THAT COULD CAUSE A FIRE THAT YOU KNOW OF

Stacy:

Recalls are VIN specific. I can check if you have your VIN. However, that should of been checked when your vehicle was at the GM dealership.

wendell:

VIN 1GKDS13S652 [REDACTED]

Stacy:

Thank you. I do not see any recalls on your vehicle.

[REDACTED]:

OK THANK YOU FOR THE HELP STACY

Stacy:

What would you like to do at this time with the issue with the vehicle? Is there a specific dealership that you wouldn't mind going back to and we can see if we can get more people involved with trying to find the issue?

[REDACTED]

NO I,LL HAVE THE ELECTRICAL WIRING HARNESS REPLACED MAYBE THAT WILL HELP THANK YOU

Stacy:

Thank you for contacting GM Customer Assistance. I hope you have a great day.

December 13, 2017

[REDACTED]  
Bay City, TX [REDACTED]

Dear [REDACTED]

We have received your request for assistance, but have been unable to contact you using the telephone number provided or any listed in our records.

If your situation has been resolved to your satisfaction, no further action is necessary. If it has not, we invite you call us at 1-800-222-1020. Please refer to the service request number listed below when you reach our representative.

Total customer satisfaction is important to us at Chevrolet. If we can be of any assistance, please don't hesitate to email us using the Contact Us link at [Chevrolet.com](http://Chevrolet.com) or call us at 1-800-222-1020.

Sincerely,

Chevrolet Customer Assistance Center

Service Request Number: [REDACTED] 4

Connecting...A live chat agent is now entering the chat. Caller English **System:** Welcome to chat. **Regina:** Thanks for contacting GM Customer Assistance. How can I assist? [REDACTED]  
[REDACTED]: I have a 2007 trailblaser and the headlights will not come on. **Regina:** Sorry to hear of this. We can assist with checking the VIN for possible recalls, refer you to your local GM dealership for technical assistance. We are unable to provide any technical recommendations.  
**Regina:** Do you have the VIN and approximate mileage? [REDACTED]: one second please  
[REDACTED] back [REDACTED]: I think there wre some notices about this problem  
[REDACTED] 1GNNDT135272 [REDACTED] 7 **Regina:** Mileage? [REDACTED]:  
1GNNDT13S272 [REDACTED] CORRECTION 61,000 MILES **Regina:** Thanks, is the contact information provided correct? We use it for documentation purposes. [REDACTED]: WHAT INFO DO YOU HAVE? **Regina:** No recall related to the concern. No warranty for coverage. I will provide you with the information for verification purposes. **Regina:**  
<https://recalls.gm.com/#/?vin=1GNNDT13S2722> [REDACTED] **Regina:** Is there anything else we can assist with? [REDACTED]: no, bye. **Regina:** Thanks for contacting GM Customer Assistance  
Caller Stephen Diebel left the call. You have been disconnected from the chat session. If you require further assistance, please start another chat session or visit [it.support.gm.com](http://it.support.gm.com) for more support options.

Connecting...A live chat agent is now entering the chat.

Caller English

System:

Welcome to chat.

Kelsey:

Thank you for contacting GM customer assistance, my name is Kelsey. To better assist can you please verify your basic contact information, your VIN and mileage?

[REDACTED]

Basic Information

[REDACTED]

vin 1gndt13s272 [REDACTED]

[REDACTED]:

Name [REDACTED]

[REDACTED]:

2007 Chev Balzer

Kelsey:

Okay Thank you, and how may I assist you today [REDACTED]

[REDACTED]

I am contacting G to find out about the recall covering 2007 chev blazers for headlight failures.

[REDACTED]:

my vehicle is in today to have this repaired and the dealership can not find out anything out about the recall

[REDACTED]

described int he recent usatoday articles

[REDACTED]:

both my low beam headlights failed, but the high beams worked

Kelsey:

As I bring up your vehicle's information Richard, there is a recall for the driver door short circuit, but there is not any recall on your vehicle pertaining to the headlamps.

[REDACTED]

[REDACTED]

Kelsey:

Recalls are certain to each VIN number and vehicle, it depends on what plant they are made in, what number in line of productions or where they get the parts from. I do apologize but that would be why they could not find the information on that recall.

[REDACTED]

my car is experiencing the same defect.

[REDACTED]:

how long does it take before the recall information is posted to the vehicles?

Kelsey:

I do see that article [REDACTED] but unfortunately at this time your vehicle isn't under that recall. If you would like to check up to date recalls, you are able to go to [recalls.gm.com](http://recalls.gm.com). It shows current recalls as well as upcoming recalls.

Kelsey:

If your vehicle does fall under this recall and does get added, if you pay for the repair, you will be able to file for reimbursement.

[REDACTED]

has this recall been posted to the GM website for covered vehicles?

[REDACTED]:

who can I talk to about the vehicles covered?

Kelsey:

It goes by VIN number, and if this was just released it could possibly not be added yet to all of them. But I would not be able to know if it is added to the vehicles until I have a VIN that is involved and added. Unfortunately, we would have to wait and see if you are one that will be added. You could get it

repaired and if your vehicle is involved you will be notified through the mail, and be able to file for reimbursement.

[REDACTED]

ok ill get the repair completed cant drive it the way it is today?

Kelsey:

I'm not technically trained sir that is something you need to ask the dealership on, they would be able to recommend on if they feel you are able to wait to see if your vehicle is involved or if you need the repair performed now.

Caller [REDACTED] left the call.

You have been disconnected from the chat session. If you require further assistance, please start another chat session or visit [it.support.gm.com](https://it.support.gm.com) for more support options.

**Customer**

██████████  
 ██████████  
 Call Unsure/Unknown

**Vehicle**

2006 Buick LaCrosse  
 2G4WD5825611 ██████████  
 Mileage now: 66000 mi

**Status of vehicle/concern**

A GM Dealer has NOT diagnosed current concern  
 Repairs have not been scheduled  
 Vehicle is currently operable & can be driven

**Key Points**

Customer advised the lights were not operable on the vehicle. The customer is seeking to have the problem diagnosed and repaired. The customer was advised that problem would have to be diagnosed to look further into any type of cost assistance if any.

Supporting Factors	Limiting Factors
Original owner (verified)  Loyal GM customer: 3 GM vehicles purchased (verified)	Vehicle is > 8 years old (verified)
<p><i>Please consider these additional questions:</i></p> <p><i>Close to any applicable expiration limit? (wrnty, spl covg, svc contrt)</i></p> <p><i>Did cust buy an extd svc contract, but it's expired or n/a?</i></p> <p><i>Is this a loyal service customer? (to involved dealer)</i></p> <p><i>Are high dollar customer-pay ROs on record for this cust?</i></p> <p><i>Is this a conquest buyer?</i></p>	<p><i>Please consider these additional questions:</i></p> <p><i>Is vehicle way beyond all applicable expiration limits?</i></p> <p><i>Does veh have an active <u>aftermarket</u> Extd Svc Contract?</i></p> <p><i>Did customer buy vehicle outside of warranty?</i></p> <p><i>Does it seem customer doesn't take care of the vehicle?</i></p> <p><i>Is cause not normally covered by warranty?</i></p> <p><i>Is cause due to an accident insurance won't cover?</i></p> <p><i>Is cause due to damage by independent repair facility?</i></p>

**Additional key points**

This customer has purchased these GM vehicles (verified): LaCrosse, Lasabre(2)

**Reference**

CAC SR#: ██████████  
 CAC advisor: Sheenette--> (866) 790-5700, Ext # 41115

**Customer**

██████████ d  
 ██████████  
 Call anytime

**Vehicle**

2004 GMC Envoy  
 1GKDS13S1422██████████  
 Mileage now: 162000 mi

**Status of vehicle/concern**

A GM Dealer has diagnosed the current concern  
 Repairs have not been scheduled  
 Vehicle is currently operable & can be driven

**Key Points**

Customer states the vehicle low beam headlights isn't working, been to 2 dealerships and neither will help him with the issue. I looked up a third dealership for the customer (Sunset Buick-GMC in Sarasota, FL BAC ██████████). I gave the customer the service phone number and hours to the dealership.

Customer seeks to get this fixed ASAP because he and his wife drive this vehicle back and forth from Florida and Georgia on a weekly basis.

I advised the customer to get the vehicle into the dealership that I provided for him so it can be diagnosed to get a resolution to the issue. I will get in contact with the CE Manager Chris Welter; Mr. Welter will get back with the customer within 24 to 48 hours with a resolution. As a courtesy can you or a service representative call Mr. Stannard to setup an appointment.

RandyCobb/CAC/WMI/T2

Supporting Factors	Limiting Factors
Original owner (verified)  First time GM buyer (verified)	Vehicle is > 8 years old (verified) Vehicle has > 100,000 miles
<p><i>Please consider these additional questions:</i></p> <p>Close to any applicable expiration limit? (wrnty, spl covg, svc contrt)</p> <p>Did cust buy an extd svc contract, but it's expired or n/a?</p> <p>Is this a loyal service customer? (to involved dealer)</p> <p>Are high dollar customer-pay ROs on record for this cust?</p> <p>Is this a conquest buyer?</p>	<p><i>Please consider these additional questions:</i></p> <p>Is vehicle way beyond all applicable expiration limits?</p> <p>Does veh have an active <u>aftermarket</u> Extd Svc Contract?</p> <p>Did customer buy vehicle outside of warranty?</p> <p>Does it seem customer doesn't take care of the vehicle?</p> <p>Is cause not normally covered by warranty?</p> <p>Is cause due to an accident insurance won't cover?</p> <p>Is cause due to damage by independent repair facility?</p>

**Additional key points**

This customer has purchased these GM vehicles (verified): 1GKDS13S142██████████ 2004 GMC ENVOY

**Reference**

CAC ██████████  
 CAC advisor: Randy Cobb--> (866) 790-5700, Ext # 41608

December 13, 2017

[REDACTED]  
Phisburg, MS [REDACTED]

Dear [REDACTED]

At Chevrolet, we take pride in the vehicles we produce and appreciate the time you took to contact us.

Because customer satisfaction is a top priority for us, please accept this letter worth up to \$100 towards your next maintenance service or repair on your 2007 Chevrolet TrailBlazer.

This offer is valid towards one service visit on VIN 1GNDT13S07 [REDACTED]. In the event the cost of your service exceeds the \$100 maximum value, you will be responsible for paying the difference. If the total cost of your services is less than \$100, a credit or refund will not be issued. This letter is not transferable and is valid for 12 months from the date of issue.

We hope this gesture demonstrates our appreciation of you as a valued customer. Simply present this letter to any Chevrolet dealership for redemption. If you have future questions, please don't hesitate to email us using the Contact Us link at Chevrolet.com or call us at 1-800-222-1020.

Sincerely,

Chevrolet Customer Assistance Center  
Service Request [REDACTED] 7

For more information regarding the maintenance and care of your vehicle, please visit [www.gm.com/vehicles/owner\\_advantages.html](http://www.gm.com/vehicles/owner_advantages.html). This free online service offers vehicle and ownership-related information and tools tailored to your specific vehicle.

---

ATTENTION: DEALERSHIP SERVICE MANAGER

When submitting the claim, please use labor op 0600046. Insert the amount in the net item column and insert the CAC Service Request number in your comments. This original letter must be surrendered by the customer and retained by the dealer for audit purposes.

# CAC SR Data Share

**Save PDF to Desktop**

**Clear Form**

**After completing the SRDS, do this:**

- 1) Grey 'Spellcheck' button to check spelling (at the bottom)
- 2) Green 'Save PDF to Desktop' button (at top)
- 3) Close the PDF file.
- 4) Copy 'Key Points' (pink cell) to new "SR Summary" Comments
- 5) Attach 'SRDS.pdf' to the SR.
- 6) Send 'SRDS.pdf' to the CE Mgr via the A02 email.
- 7) Red 'Clear Form' button (at the top)
- 8) Repeat (Save over the same generic 'SRDS.pdf' file all day long.)

Customer's name (for your reference): [REDACTED] 7

Key Points: Customer seeking head light concern to be addressed and repaired .  
Informed that head light shuts off while driving .

**What is the customer's concern?**  
**What help is the customer seeking?**  
**What expectations did you set for the customer?**

Customer's preferred phone [REDACTED]

Best time to call customer: open

Has the customer had the current concern diagnosed by a GM Dealer?	A GM Dealer has NOT diagnosed current concern
What is the status of the repairs (to address the current concern)?	Repairs have not been scheduled
How many times has vehicle been serviced for this same concern (at any svc location)?	0
How many <u>days</u> has vehicle been inoperable (down) because of this concern?	0
Current status of the vehicle (operable or inoperable)?	Vehicle is currently operable & can be driven
Has customer spent money out-of-pocket as a result of this concern?	No
Current mileage (in <u>miles</u> )?	175,000
Bought brand new?	No
<i>(if bought used)</i> Roughly how many <u>miles</u> were on the vehicle at time of purchase?	
<i>(if bought used)</i> Was vehicle bought (used) at a GM Dealership?	
Did customer purchase an Extended Service Contract (GM, Divisional, Aftermarket)?	No

**End conversation with the customer here.** Complete the rest of the SR Data Share in ACW (After Call Work).

Today's date:	1/23/2015
SR#:	
CAC advisor's name (first & last):	Stephanie
CAC advisor's phone #:	(866) 790-5700
CAC advisor's extension #:	41376
17-digit VIN#:	1GNDT13S07
Make:	Chevrolet
Model:	Trailblazer
Model Year:	2006
Is this a high-dollar or premium vehicle?	No
Does this VIN have any <u>active</u> Extended Service Contracts?	No
Does Order Type contain the word "FLEET"?	No
Branded Title?	No
Warranty Block?	No
Warranty Start Date for this VIN:	11/10/2006

*(if bought used)* Is this a GM Certified pre-owned used vehicle?

--

Is this the original owner? No

List of GM vehicles owned by this customer:  
*(including the vehicle they're calling about now)*

2007 CHEVROLET TRAILBLAZER

Total number of GM vehicles this customer has owned:  
*(including the vehicle they're calling about now)*

1
---

**Customer**

██████████7  
 (██████████)  
 Call open

**Vehicle**

2006 Chevrolet Trailblazer  
 1GNDT13S0721██████████  
 Mileage now: 175000 mi

**Status of vehicle/concern**

A GM Dealer has NOT diagnosed current concern  
 Repairs have not been scheduled  
 Vehicle is currently operable & can be driven

**Key Points**

Customer seeking head light concern to be addressed and repaired . Informed that head light shuts off while driving .

Supporting Factors	Limiting Factors
<p>First time GM buyer (verified)</p>	<p>Vehicle is &gt; 8 years old (verified)                      Vehicle has &gt; 100,000 miles</p>
<p><u>Please consider these additional questions:</u>                      Close to any applicable expiration limit? (wrnty, spl covg, svc contrt)                      Did cust buy an extd svc contract, but it's expired or n/a?                      Is this a loyal service customer? (to involved dealer)                      Are high dollar customer-pay ROs on record for this cust?                      Is this a conquest buyer?</p>	<p><u>Please consider these additional questions:</u>                      Is vehicle way beyond all applicable expiration limits?                      Does veh have an active <u>aftermarket</u> Extd Svc Contract?                      Did customer buy vehicle outside of warranty?                      Does it seem customer doesn't take care of the vehicle?                      Is cause not normally covered by warranty?                      Is cause due to an accident insurance won't cover?                      Is cause due to damage by independent repair facility?</p>

**Additional key points**

This customer has purchased these GM vehicles (verified): 2007 CHEVROLET TRAILBLAZER

**Reference**

CAC SR#: ██████████  
 CAC advisor: Stephanie--> (866) 790-5700, Ext # 41376

## **General Excel Tips:**

Right click on any cell with a comment & choose "Show/Hide Comments" to make the Comment stick (stay visible)  
When you're done, Right click the cell with the comment showing & choose "Show/Hide Comments" to make the

Ctrl+C to copy; Ctrl+V to paste; Ctrl+X to cut

If you leave & come back, click inside the cell & pick up at the blinking cursor (to prevent typing on top of what was

Alt+Enter lets you return to the next line inside a cell

Alt + down arrow key will show you the dropdown menu/choices list (do this if you don't like using a mouse)

even when you click away from that cell).  
Comment go away (become hidden from immediate view).

is already there)



Hummer

Yes - This V

Unresolved - Customer No - This is

Diagnosed

No

IN has received goodwill or cost assistance

a new SR



December 13, 2017

[REDACTED]  
Novi, MI [REDACTED]

[REDACTED],  
At Chevrolet, we take pride in the vehicles we produce and appreciate the time you took to contact us.

Because customer satisfaction is a top priority for us, please accept this letter worth up to \$100 towards your next maintenance service or repair on your 2005 Chevrolet TrailBlazer.

This offer is valid towards one service visit on VIN 1GNES16M05[REDACTED]. In the event the cost of your service exceeds the \$100 maximum value, you will be responsible for paying the difference. If the total cost of your services is less than \$100, a credit or refund will not be issued. This letter is not transferable and is valid for 12 months from the date of issue.

We hope this gesture demonstrates our appreciation of you as a valued customer. Simply present this letter to any Chevrolet dealership for redemption. If you have future questions, please don't hesitate to contact Wendy at our Executive Office at 1-855-880-1500 extension 21796. Please refer to your service request number listed below and we will be happy to assist you.

Sincerely,

Chevrolet Executive Office  
Service Request [REDACTED]

For more information regarding the maintenance and care of your vehicle, please visit [www.gm.com/vehicles/owner\\_advantages.html](http://www.gm.com/vehicles/owner_advantages.html). This free online service offers vehicle and ownership-related information and tools tailored to your specific vehicle.

---

ATTENTION: DEALERSHIP SERVICE MANAGER

When submitting the claim, please use labor op 0600046. Insert the amount in the net item column and insert the CAC Service Request number in your comments. This original letter must be surrendered by the customer and retained by the dealer for audit purposes.

Please assign to SEAL team for handling. This one looks like it slipped through the cracks and was never sent to us so we're behind the 8 ball a bit.

Aaron Charbonneau  
Business Process Leader, Executive Customer Assistance and Electric Vehicle Team  
GMNA Customer Experience  
Customer and Relationship Services (CARS)  
aaron.charbonneau@gm.com<mailto:aaron.charbonneau@gm.com>

  
[cid:image001.jpg@01CF533A.7F3E6D80]

From: Pamela Bushey (C) On Behalf Of Alicia S Boler Davis  
Sent: Thursday, January 29, 2015 1:19 PM  
To: Aaron Charbonneau  
Subject: FW: headlamp recall

Aaron,

It appears that this was not addressed.

From: Mary T. Barra  
Sent: Thursday, December 04, 2014 6:18 PM  
To: Alicia S Boler Davis  
Subject: FW: headlamp recall

Please investigate and respond to this employee on my behalf. Thanks.

From:   
Date: Thursday, December 4, 2014 10:59 AM  
To: "mary.barra@gm.com<mailto:mary.barra@gm.com>"  
<mary.barra@gm.com<mailto:mary.barra@gm.com>>  
Subject: headlamp recall

Mary Barra

This week GM announced a recall on selected GM vehicles, my 2005 trailblazer ext. is not included on this list of vehicles. The past three months the headlamps have quit working several times on my 2005

TB. My wife has been out driving at night, then out of no-where they go off. This is a very dangerous situation, especially my sub-division has no lights, and other roads have little lighting in Novi. I told her, not to drive it after dark, but sometimes that cant be prevented. I think the recall should include 2005 Trailblazers Ext.

[REDACTED]

[REDACTED]

Nothing in this message is intended to constitute an electronic signature unless a specific statement to the contrary is included in this message.

Confidentiality Note: This message is intended only for the person or entity to which it is addressed. It may contain confidential and/or privileged material. Any review, transmission, dissemination or other use, or taking of any action in reliance upon this message by persons or entities other than the intended recipient is prohibited and may be unlawful. If you received this message in error, please contact the sender and delete it from your computer.

[2:11:21 PM] Connecting...A live chat agent is now entering the chat.

[2:11:21 PM] Caller English

System:

[2:11:21 PM] Welcome to chat.

Aphifannie:

[2:11:25 PM] Hi! Thank you for visiting us today. How may I help you?

[REDACTED]:

[2:11:25 PM] hello

[REDACTED]r:

[2:11:56 PM] i have a 2008/2007 Trail Blazer tht has the head lamp problem

[REDACTED]

[2:12:31 PM] the vin is not on the recall list, but it has exact problems

[REDACTED]:

[2:13:35 PM] this suv seems to be more of a 2007 that has had many of those problems

Aphifannie:

[2:14:12 PM] I am sorry to hear that you are having this concern. Do you have the VIN and mileage available?

[REDACTED]:

[2:14:49 PM] 49.500 1GNLT13S882 [REDACTED]

Aphifannie:

[2:16:09 PM] I am not any open recalls at this time. I am unable to view recall information that has not been attached to a customers' VIN. Recalls are VIN specific and issued by NHTSA based on a number of different factors. A diagnosis will give our technicians a better idea as to how to approach the issue you are experiencing. I would recommend taking your vehicle to a GM dealership to get a diagnosis. If you would like I can locate one for you?

[REDACTED]

[2:17:40 PM] well i have looked up all recall info with nhtsa and the 2007/2009 are on the list.

[2:17:57 PM] i have the headlamp problem just as discribed

Aphifannie:

[2:19:03 PM] I am seeing that your vehicle is a 2008 model year. I am not seeing any recalls at this time. I would suggest getting a diagnoses at a GM dealer to see what is wrong with head lamp.

[REDACTED]:

[2:20:25 PM] my suv was manufactured in 2007 and has had all the recall problems of that year...now the headlamps....you tell me that the diagnostic assessment will be free of charge and i bring it in...

[REDACTED]:

[2:22:19 PM] silence!

[REDACTED]:

[2:24:06 PM] APHIFANNIE

Aphifannie:

[2:25:39 PM] What I can do is waive an hour on diagnostic fees. The recalls are VIN specific and I am not seeing any on your vehicle. Many vehicles that are produced in 2007 are the model year 2008. What I can do is locate a Gm dealer for you to get a diagnoses on your vehicle.

[2:26:58 PM] Caller [REDACTED] left the call.

[2:27:00 PM] You have been disconnected from the chat session. If you require further assistance, please start another chat session or visit [it.support.gm.com](http://it.support.gm.com) for more support options.

# CAC SR Data Share

**Save PDF to Desktop**

**Clear Form**

## After completing the SRDS, do this:

- 1) Grey 'Spellcheck' button to check spelling (at the bottom)
- 2) Green 'Save PDF to Desktop' button (at top)
- 3) Close the PDF file.
- 4) Attach 'SRDS.pdf' to the SR.
- 5) Send 'SRDS.pdf' to the CE Mgr via the A02 email.
- 6) Red 'Clear Form' button (at the top)
- 7) Repeat (Save over the same generic 'SRDS.pdf' file all day long.)

Customer's name (for your reference): Wayne Perkins

Key Points: Custome concern:

**What is the customer's concern?**  
**What help is the customer seeking?**  
**What expectations did you set for the customer?**

-the headlights are not working  
-they replaced something and then it worked for a while and now it is doing it again  
-took it back three weeks ago  
-I think that the head light system has some issues and that there is too much voltage running off of one thing  
-my car is stilling having the issue  
-GM only has a temp fix for the issue as of now

Customer seeks:

-permant or temp fix that works

< Caitlin Coker /CAC/ATX/T2/L2 empowered >

Customer's preferred phone #: ( [REDACTED] )

Best time to call customer: anytime

Has the customer had the current concern diagnosed by a GM Dealer?	A GM Dealer has diagnosed the current concern
What is the status of the repairs (to address the current concern)?	Repairs are all complete
How many times has vehicle been serviced for this same concern (at any svc location)?	2
How many <u>days</u> has vehicle been inoperable (down) because of this concern?	0
Current status of the vehicle (operable or inoperable)?	Vehicle is currently operable & can be driven
Has customer spent money out-of-pocket as a result of this concern?	No
Current mileage (in <u>miles</u> )?	162,000
Bought brand new?	Yes
<i>(if bought used)</i> Roughly how many <u>miles</u> were on the vehicle at time of purchase?	
<i>(if bought used)</i> Was vehicle bought (used) at a GM Dealership?	
Did customer purchase an Extended Service Contract (GM, Divisional, Aftermarket)?	No

**End conversation with the customer here.** Complete the rest of the SR Data Share in ACW (After Call Work).

Today's date:	2/16/2015
SR#:	
CAC advisor's name (first & last):	Caitlin Coker
CAC advisor's phone #:	(866) 790-5600
CAC advisor's extension #:	11331
17-digit VIN#:	1GNDT13S462
Make:	Chevrolet
Model:	Trailblazer
Model Year:	2006
Is this a high-dollar or premium vehicle?	
Does this VIN have any <u>active</u> Extended Service Contracts?	No
Does Order Type contain the word "FLEET"?	
Branded Title?	No
Warranty Block?	No
Warranty Start Date for this VIN:	11/23/2005

***(if bought used)*** Is this a GM Certified pre-owned used vehicle?

Is this the original owner? Yes

List of GM vehicles owned by this customer:  
*(including the vehicle they're calling about now)*

2006 Ttailblazer

Total number of GM vehicles this customer has owned:  
*(including the vehicle they're calling about now)*

1

**Customer**

[Redacted]

Call anytime

**Vehicle**

2006 Chevrolet Trailblazer

1GNDT13S462 [Redacted]

Mileage now: 162000 mi

**Status of vehicle/concern**

A GM Dealer has diagnosed the current concern

Repairs are all complete

Vehicle is currently operable & can be driven

**Key Points**

Customer concern:

- the headlights are not working
- they replaced something and then it worked for a while and now it is doing it again
- took it back three weeks ago
- I think that the head light system has some issues and that there is too much voltage running off of one thing
- my car is stilling having the issue
- GM only has a temp fix for the issue as of now

Customer seeks:

- permant or temp fix that works

Supporting Factors	Limiting Factors
<p>Original owner (verified)</p> <p>First time GM buyer (verified)</p> <p>Vehicle has been serviced for this concern: 2 time(s)</p>	<p>Vehicle is &gt; 8 years old (verified)</p> <p>Vehicle has &gt; 100,000 miles</p>
<p><u>Please consider these additional questions:</u></p> <p>Close to any applicable expiration limit? (wrnty, spl covg, svc contrt)</p> <p>Did cust buy an extd svc contract, but it's expired or n/a?</p> <p>Is this a loyal service customer? (to involved dealer)</p> <p>Are high dollar customer-pay ROs on record for this cust?</p> <p>Is this a conquest buyer?</p>	<p><u>Please consider these additional questions:</u></p> <p>Is vehicle way beyond all applicable expiration limits?</p> <p>Does veh have an active <u>aftermarket</u> Extd Svc Contract?</p> <p>Did customer buy vehicle outside of warranty?</p> <p>Does it seem customer doesn't take care of the vehicle?</p> <p>Is cause not normally covered by warranty?</p> <p>Is cause due to an accident insurance won't cover?</p> <p>Is cause due to damage by independent repair facility?</p>

**Additional key points**

This customer has purchased these GM vehicles (verified): 2006 Ttailblazer

**Reference**

CAC SR#: [Redacted]

CAC advisor: Caitlin Coker --> (866) 790-5600 , Ext # 11331

## **General Excel Tips:**

Right click on any cell with a comment & choose "Show/Hide Comments" to make the Comment stick (stay visible)  
When you're done, Right click the cell with the comment showing & choose "Show/Hide Comments" to make the

Ctrl+C to copy; Ctrl+V to paste; Ctrl+X to cut

If you leave & come back, click inside the cell & pick up at the blinking cursor (to prevent typing on top of what was

Alt+Enter lets you return to the next line inside a cell

Alt + down arrow key will show you the dropdown menu/choices list (do this if you don't like using a mouse)

even when you click away from that cell).  
Comment go away (become hidden from immediate view).

is already there)



Hummer

Yes - This V

Unresolved - Customer No - This is

Diagnosed

No

IN has received goodwill or cost assistance

a new SR



System:

[4:16:38 PM] Connecting...A live chat agent is now entering the chat.[4:16:38 PM] Welcome to chat.

[4:16:38 PM] Caller English

System:

[4:16:38 PM] [4:16:38 PM] Welcome to chat.

Stacy:

[4:16:45 PM] Thank you for contacting GM Customer Assistance. My name is Stacy. To better assist you; may I please have your VIN and approximate mileage on the vehicle to begin?

[REDACTED]:

[4:17:26 PM] I will have to go out to the vehicle and get the VIN.

Stacy:

[4:17:50 PM] Thank you very much.

T [REDACTED]

[4:23:34 PM] VIN 1GNET16S846 [REDACTED] mileage: 132,000.

Stacy:

[4:23:51 PM] Thank you very much, Terry. How may I help you today?

[REDACTED]

[4:26:41 PM] A couple of things. First, what are the part numbers of the OEM radio/single cd Players that will work in my 2004 Trailblazer. And I cannot get the Daytime Running Lights to come on. What is the secret? They were working Friday.

Stacy:

[4:28:01 PM] I am sorry to hear about the lights. With the lights, they should automatically come on, if they are the automatic daytime running lights. In regards to the part numbers, that is something that we do not have here at customer assistance.

[REDACTED]

[4:29:33 PM] Well the DRL lights are not coming on in the automatic mode. And who do I call about the Radios?

Stacy:

[4:30:08 PM] Do you have a preferred Chevrolet dealership? They would be able to assist with ordering parts.

[REDACTED]:

[4:31:28 PM] I think the DRL lights just need to be reset. Who do I call about this?

Stacy:

[4:32:55 PM] I can see if the information is in the owners manual. However, if it is not, the dealer would need to assist.

[REDACTED]:

[4:33:29 PM] I have looked at the manual. Thanks anyway.

Stacy:

[4:34:14 PM] If you have looked in the manual, did you see the section on the exterior lamps? In regards to the knob for the lamps, it should be turned on, instead of off.

Stacy:

[4:35:01 PM] I did create a case here for you. The number is [REDACTED]

[4:36:21 PM] Caller [REDACTED] left the call.

[4:36:22 PM] You have been disconnected from the chat session. If you require further assistance, please start another chat session or visit [it.support.gm.com](https://it.support.gm.com) for more support options.

**Customer**

██████████  
 ██████████  
 Call 0.5

**Vehicle**

2007 Chevrolet TrailBlazer  
 1GNDT13S2721██████████  
 Mileage now: 160000 mi

**Status of vehicle/concern**

A GM Dealer has diagnosed the current concern  
 Repairs have not been scheduled  
 Vehicle is currently operable & can be driven

**Key Points**

-i got a problem with my headlight; i understand there was a recall on that so i wanted to know if i had one  
 -sometimes they don't come on and then they'll come on and not to off for 2 hours

Supporting Factors	Limiting Factors
Loyal GM customer: 5 GM vehicles purchased (verified)  Vehicle has been serviced for this concern: 1 time(s)	Vehicle is > 8 years old (verified) Vehicle has > 100,000 miles Current or former fleet vehicle (verified)
<p><i>Please consider these additional questions:</i>                      Close to any applicable expiration limit? (wrnty, spl covg, svc contrt)                      Did cust buy an extd svc contract, but it's expired or n/a?                      Is this a loyal service customer? (to involved dealer)                      Are high dollar customer-pay ROs on record for this cust?                      Is this a conquest buyer?</p>	<p><i>Please consider these additional questions:</i>                      Is vehicle way beyond all applicable expiration limits?                      Does veh have an active <u>aftermarket</u> Extd Svc Contract?                      Did customer buy vehicle outside of warranty?                      Does it seem customer doesn't take care of the vehicle?                      Is cause not normally covered by warranty?                      Is cause due to an accident insurance won't cover?                      Is cause due to damage by independent repair facility?</p>

**Additional key points**

Per the customer, this vehicle was bought (used) at a GM Dealership  
 Approximate # of miles on the vehicle when customer purchased it (used): 49215 mi  
 This customer has purchased these GM vehicles (verified): 1GNDT13S272██████████, 1G4HD57236U1██████████7,  
 1GCEC19S4RE1██████████2GCEC19C1L1██████████ 1GBEG25K4K71██████████

**Reference**

████████████████████  
 CAC advisor: Amanda Jacaman--> (866) 790-5700, Ext # 21231

**Customer**

██████████  
 ██████████  
 Call Any Time

**Vehicle**

2005 Chevrolet Trail Blazer  
 1GNES16S6561 ██████████  
 Mileage now: 85000 mi

**Status of vehicle/concern**

A GM Dealer has NOT diagnosed current concern  
 Repairs have not been scheduled  
 Vehicle is currently operable & can be driven

**Key Points**

Customer states that he has issue on the low beam headlights. The customer said that his wife was driving at night that when the low beam would not work. He took the vehicle into the dealer who advised that he must paid his diagnostic fee. The customer is should be a recall issue because he found a lot of complaint on the internet. The customer knows he need a headlight relay switch for the low beams.

Customer seeks cost assistance

CRS advised the customer that his vehicle is out of warranty, so cost assistance is not guaranteed. I expressed my apology for any inconveniences this issue has caused. I also told the customer that I will be assigning his case to the dealership's customer experience manager. His name is Elizabeth Dwyer. She will be the eyes and ears at the dealer, she is in the best possible position to address your concern and will be your single point of contact throughout the resolution of this process. I will ask the CE Manager will reach out to you within a twenty-four (24) business hours to discuss the issue and deliver the resolution. Phone the service dept. to make an appointment with a service advisor. The call was then transferred to the CE Manager Elizabeth Dwyer. Knowing the customer and I was on a conference call, the CE Manager beginning to berated the S A regarding the GM customer care center policies. The customer interrupted the conversation and advised he will never

<b>Supporting Factors</b>	<b>Limiting Factors</b>
Original owner (verified)  First time GM buyer (verified)	Vehicle is > 8 years old (verified)
<p><i>Please consider these additional questions:</i>                      Close to any applicable expiration limit? (wrnty, spl covg, svc contrt)                      Did cust buy an extd svc contract, but it's expired or n/a?                      Is this a loyal service customer? (to involved dealer)                      Are high dollar customer-pay ROs on record for this cust?                      Is this a conquest buyer?</p>	<p><i>Please consider these additional questions:</i>                      Is vehicle way beyond all applicable expiration limits?                      Does veh have an active <u>aftermarket</u> Extd Svc Contract?                      Did customer buy vehicle outside of warranty?                      Does it seem customer doesn't take care of the vehicle?                      Is cause not normally covered by warranty?                      Is cause due to an accident insurance won't cover?                      Is cause due to damage by independent repair facility?</p>

**Additional key points**

This customer has purchased these GM vehicles (verified): 2005 Chevrolet Trailblazer

**Reference**

CAC SR#: ██████████

CAC advisor: Cheryl--> (866) 790-5700, Ext # 41597

*Some information in this report could not be verified/validated. Verified information is indicated as such, and was pulled from GM Databases.*



## 2007 Chevrolet TrailBlazer

Style: **LS Sport Utility 4D** ▾

[Edit options](#) | [Check specs](#)



Mileage: **110000**

[Change](#)

Like

32

[Trade In to a Dealer](#)

[Get an Instant Cash Offer](#) ⓘ

[Sell to a Private Party](#)

[Print report](#)

Trade-in Value

**\$5,182**



### Price a New Car

Then browse reviews, photos, specs and more.

[See what you should pay](#)

### Instant Cash Offer

Find local dealers ready to buy your car - today!

[Get your offer](#)

powered by AutoTrader

[Good Condition](#) ⓘ



# Cadillac

**HOEHN BUICK GMC**

THERE IS NO PLACE LIKE HOEHN

2015 **ATS** SEDAN

\*OFFER DETAILS



**Hoehn**  
CARLSBAD

[LEARN MORE](#)



The All-New 2  
Kia Sorento  
advertis

Advertisement

Why ads?

**FIND NEW ROADS**



[LEARN MORE](#)

**QUALITY CHEVROLET ESCONDIDO**

[www.QualityChevy.com](http://www.QualityChevy.com)

Fire Case template

Type of case	Melt Case	
Status	Closed	
SR Number	[REDACTED]	
Customer Name (Last name/First Name)	[REDACTED]	
Year/Make/Model	2007 Chevrolet Trailblazer	
VIN	1GNDT13SX722 [REDACTED]	
Incident Date	02/19/2015	
Purchase Date	Five years ago	
Titled in who's name	[REDACTED]	
Purchase Price	Unknown	
Open/Closed Recalls (If closed include closed Transaction History)	<p><i>Product Safety Recall 12180 DRIVER DOOR SWITCH SHORT CIRCUIT 02/18/2013 Closed by Watson Chevrolet, INC 625 W Auto Mall Dr Tucson, AZ 85705-6010</i></p>	
Mileage	110,000	
Purchased From	CarMax	
Vehicle Insured	Yes	
MSRP/KBB (Trade-in Good Value)	\$5,182.00	
Loaner Vehicle (yes/no from drop down and enter date issued)	No	

Additional Information as requested by TC/TL



**Susan Clark/Austin/GM1**

02/25/2015 04:42 PM

To rfoster@simpsongm.com

cc

bcc

Subject Fw: SR [REDACTED] - Cust: Zusman - 2007 Chevrolet Trailblazer - 72309769

Customer Relationship Specialist: Susan  
Telephone: 866-790-5600 x 11265

Good Afternoon, Ms. Foster,

I just wanted to do a quick follow up and ask where we are on this one? Were you able to assist the customer, or did the customer have to pay for the repair?

Thank You.

If you have further questions, please contact Customer Relationship Specialist Susan at 866-790-5600 x 11265, or by fax at 866-857-3112. You may also contact the Customer Engagement Center at 800-231-1841, Monday through Friday between 8:00 am and 5:00 pm, Eastern Time. Please refer to the service request number above.

Sincerely,

General Motors

----- Forwarded by Susan Clark/Austin/GM1 on 02/25/2015 04:41 PM -----



**Susan Clark/Austin/GM1**

02/24/2015 06:57 PM

To rfoster@simpsongm.com

cc

Subject Fw: SR [REDACTED] - Cust: Zusman - 2007 Chevrolet Trailblazer - 72309769

Ms. Foster,

I was doing some additional research on this concern, and I found a dealer message that I believe may be applicable. The message is G\_0000205389, dated January 21, 2015, the subject is "Upcoming Safety Recall 14291 - Update Customer Letter Mailing". I found this message in the archives in DealerWorld. This recall has not been released yet, but the description of the concern does seem to be the same as described by the customer. The message includes directions for a temporary repair until the recall is released.

You are probably already aware of this message, but I wanted to share this information, since it does appear to relate directly to this customer's vehicle concern.

If you have further questions, please contact Customer Relationship Specialist Susan at 866-790-5600 x 11265, or by fax at 866-857-3112. You may also contact the Customer Engagement Center at 800-231-1841, Monday through Friday between 8:00 am and 5:00 pm, Eastern Time. Please refer to the service request number above.

Sincerely,

General Motors

----- Forwarded by Susan Clark/Austin/GM1 on 02/24/2015 06:49 PM -----



**Susan Clark/Austin/GM1**

02/24/2015 06:08 PM

To rfoster@simpsongm.com

cc

Subject SR # [REDACTED] - Cust [REDACTED] 2007 Chevrolet  
Trailblazer - 72309769

Ms. Foster,

Just a quick follow up, as requested, customer is requesting estimate for diagnosis / repair of concern with the Daytime Running Lamps and headlamps being inoperative.

If you have further questions, please contact Customer Relationship Specialist Susan at 866-790-5600 x 11265, or by fax at 866-857-3112. You may also contact the Customer Engagement Center at 800-231-1841, Monday through Friday between 8:00 am and 5:00 pm, Eastern Time. Please refer to the service request number above.

Sincerely,

General Motors

Type of case	Fire Case	Case Summary
Status	Closed	<p>Allegation;Customer alleges the fuse box was defective, and it caused a fire. Customer seeks a repair of the vehicle.</p> <p>Customer has filed an insurance claim.</p> <p>Closing file, customer has made an insurance claim.</p>
SR Number	[REDACTED]	
Customer Name (Last name/First Name)	[REDACTED]	
Year/Make/Model	2002, Chevrolet, Trailblazer	
VIN	1GNDS13S92 [REDACTED]	
Incident Date	3/4/2015	
Purchase Date	12/20/2012	
Titled in who's name	customer's	
Purchase Price	\$6,000	
Open/Closed Recalls (If closed include closed Transaction History)	<p><i>Product Safety Recall 04005 WINDSHIELD WIPER MOTOR FAILURE 07/06/2004 Closed, 11/02/2004 ZFAT----Field Action Recall V1115 - 04005 - Inspect WSW Module and Install Seal Assembly 62,435 MI</i></p> <p><i>Noncompliance Recall 03012 TRANSMISSION SHIFT LOCK AND IGNITION KEY REMOVAL OVERRIDE COMPLIANCE 05/21/2003 Closed, 06/07/2003 015046 ZFAT----Field Action Recall V0994 - 03012-INSTALL PLUG AND REMOVE OVERRIDE LEVER 33,547 MI</i></p> <p><i>Product Safety Recall 04087 TAIL LAMPS/STOP LAMPS 11/16/2004 Closed, 02/11/2005 ZFAT----Field Action Recall V1265 - 04087 - Inspect and Replace One or Both Tail Lamp Circuit Boards and Lamps 66,858 MI</i></p> <p><i>Customer Satisfaction Program N030013 03013 INSTRUMENT PANEL CLUSTER GAUGES INOPERATIVE 05/22/2003 Closed, 06/07/2003 ZFAT----Field Action Recall V0995 - 03013-REPROGRAM IP CLUSTER 33,547 MI</i></p> <p><i>Product Safety Recall 02016 FUEL FILTER FITTING DISCONNECT 05/07/2002 Closed, 11/02/2004 ZFAT----Field Action Recall</i></p>	

	<i>V1115 - 04005 - Inspect WSW Module and Install Seal Assembly  62,435 MI  Noncompliance Recall 04037 FRONT SEAT BELT RETRACTOR  NONCOMPLIANCE 06/17/2004 Closed</i>	
Mileage	192,000	
Purchased From	<i>Used Car Lot</i>	
Vehicle Insured	Yes	
MSRP/KBB (Trade-in Good Value)	\$1,892.00	
Loaner Vehicle (yes/no from drop down and enter date issued)	No	
Additional Information as requested by TC/TL		

**Customer**

██████████  
 ██████████  
 Call Anytime

**Vehicle**

2008 Buick LaCrosse  
 2G4WD582981 ██████████  
 Mileage now: 80000 mi

**Status of vehicle/concern**

A GM Dealer has diagnosed the current concern  
 Repairs are in-progress (vehicle is in shop now)  
 Vehicle is currently operable & can be driven

**Key Points**

Customer sts:

I bought my car used not too long ago. My headlights went out and now I need a headlamp module. I was told it would cost me \$125 and I don't think I should pay for any of it.

Customer sks:

GM should fix it for free or at least give me cost assistance.

SA Adv:

We do have guidelines we need to follow just like the dealers. I can't promise anything but let me contact the CEM, Jessica Linder, together we'll see what options we have to possibly assist you.

LauraWalker/WRNMI/CAC-T2

Supporting Factors	Limiting Factors
<p>First time GM buyer (verified)</p> <p>High-dollar or premium vehicle</p> <p>Vehicle has been serviced for this concern: 1 time(s)                      Vehicle was inop/down due to this concern: 1 day(s)</p>	
<p><u>Please consider these additional questions:</u>                      Close to any applicable expiration limit? (wrrnty, spl covg, svc contrt)                      Did cust buy an extd svc contract, but it's expired or n/a?                      Is this a loyal service customer? (to involved dealer)                      Are high dollar customer-pay ROs on record for this cust?                      Is this a conquest buyer?</p>	<p><u>Please consider these additional questions:</u>                      Is vehicle way beyond all applicable expiration limits?                      Does veh have an active <u>aftermarket</u> Extd Svc Contract?                      Did customer buy vehicle outside of warranty?                      Does it seem customer doesn't take care of the vehicle?                      Is cause not normally covered by warranty?                      Is cause due to an accident insurance won't cover?                      Is cause due to damage by independent repair facility?</p>

**Additional key points**

Per the customer, this vehicle was bought (used) at a GM Dealership  
 Approximate # of miles on the vehicle when customer purchased it (used): 74000 mi  
 This customer has purchased these GM vehicles (verified): 08-LaCrosse

**Reference**

CAC ██████████  
 CAC advisor: Laura Walker--> (866) 790-5600 , Ext # 31551

Nancy Novak (C)

---

From: Nancy Novak (C)  
Sent: Friday, March 13, 2015 8:13 AM  
To: [REDACTED]  
Subject: PAC SR # [REDACTED]

I am so sorry to hear of your vehicle issue. We will need the fire department report (if applicable), a copy of your title, and the pictures listed below. You need to be the registered owner of this vehicle. If your vehicle is at a storage/tow yard, please make sure parts were not removed from the vehicle. Your vehicle needs to be in the original state after the fire/melt. The vehicle must have all four tires still on it. Unfortunately, GM will not reimburse storage fees incurred while your vehicle is at a storage/tow yard.

GM needs the following pictures:

- \* one picture showing the entire outside of driver side
- \* one picture showing the entire outside of passenger side
- \* one picture showing the entire outside of the front of the vehicle
- \* one picture showing the entire outside of the back of the vehicle
- \* one picture showing the engine area with melt damage clearly evident
- \* one close-up picture of the fuse box melt damage

Thank you,

**Nancy Novak**  
GM Product Assistance Claims  
Tel: 866.446.6963 ext 21628  
Fax: 866-255-3845  
[Nancy.Novak@GM.com](mailto:Nancy.Novak@GM.com)

Type of case	Melt Case	Case Summary
Status	Closed	Allegation;HDM fuse melted in my fuse block
SR Number	[REDACTED]	
Customer Name (Last name/First Name)	[REDACTED]	
Year/Make/Model	2005/Chevrolet/Trailblazer	
VIN	1GNDT13S6 [REDACTED]	
Incident Date	3/8/2015	
Purchase Date	Unknown	
Titled in who's name	[REDACTED]	
Purchase Price	Unknown	
Open/Closed Recalls (If closed include closed Transaction History)	None	
Mileage	129,000	
Purchased From	Unknown	
Vehicle Insured	No	
MSRP/KBB (Trade-in Good Value)	N/A	

Loaner Vehicle (yes/no from drop down and enter date issued)	No		
Additional Information as requested by TC/TL			



Has the customer had the current concern diagnosed by a GM Dealer?	A GM Dealer has diagnosed the current concern
What is the status of the repairs (to address the current concern)?	Repairs are all complete
How many times has vehicle been serviced for this same concern (at any svc location)?	0
How many <u>days</u> has vehicle been inoperable (down) because of this concern?	0
Current status of the vehicle (operable or inoperable)?	Vehicle is currently operable & can be driven
Has customer spent money out-of-pocket as a result of this concern?	Yes
Current mileage (in <u>miles</u> )?	99,000
Bought brand new?	Yes
<i>(if bought used)</i> Roughly how many <u>miles</u> were on the vehicle at time of purchase?	
<i>(if bought used)</i> Was vehicle bought (used) at a GM Dealership?	
Did customer purchase an Extended Service Contract (GM, Divisional, Aftermarket)?	No

**End conversation with the customer here. Complete the rest of the SR Data Share in ACW (After Call Work).**

Today's date:	3/19/2015
SR#:	██████████8
CAC advisor's name (first & last):	Janelle Wright
CAC advisor's phone #:	(866) 790-5700
CAC advisor's extension #:	41580
17-digit VIN#:	1GKDS33S892 ██████████
Make:	GMC
Model:	Envoy
Model Year:	2009
Is this a high-dollar or premium vehicle?	No
Does this VIN have any <u>active</u> Extended Service Contracts?	No
Does Order Type contain the word "FLEET"?	No
Branded Title?	No
Warranty Block?	No
Warranty Start Date for this VIN:	12/24/2008

*(if bought used)* Is this a GM Certified pre-owned used vehicle?

Is this the original owner? Yes

List of GM vehicles owned by this customer:  
*(including the vehicle they're calling about now)*

99-Regal, 03-Grand Am, 04-Envoy, 06-Cobalt, 09-Envoy

Total number of GM vehicles this customer has owned:  
*(including the vehicle they're calling about now)*

8

8+1

ZIP CODE: 77084 | Sign in (or Sign up)

Home | Car Values | Cars for Sale | Car Reviews | Awards & Top 10s | Research Tools

Popular at KBB.com

10 Most Fuel-Efficient SUVs

Advertisement

Why ads?

Home > Car Values > Chevrolet > TrailBlazer > 2007 > Style > Options > LT Sport Utility 4D

Chevrolet TrailBlazer 2007 Go

# Your Blue Book® Value [Show Used Car Prices](#) | [Price Your Next Car](#)



## 2007 Chevrolet TrailBlazer

Style: LT Sport Utility 4D

[Edit options](#) | [Check specs](#)

Mileage: 120000 [Change](#)

Like 19

[Trade In to a Dealer](#)

[Get an Instant Cash Offer](#)

[Sell to a Private Party](#)

[Print report](#)



Good Condition

Trade-in Values valid for your area through 4/2/2015  
[Track this car's values](#)

### Price a New Car

Then browse reviews, photos, specs and more.

[See what you should pay](#)

### Instant Cash Offer

Find local dealers ready to buy your car - today!

[Get your offer](#)

backed by

[See Special Offer](#)

Advertisement

Why ads?

### Tell Us About This Car

Owners like you rated the 2007 TrailBlazer 8.2 out of 10.

[Write your own review](#)

### Next Steps to Selling Your Car

#### Benchmark Local Prices

See what dealers and private sellers in your area are asking for your car.

[See listings](#)

#### Give Buyers Confidence

Show them a clean AutoCheck vehicle

[Go](#)

Advertisement

Why ads?

Recently Viewed Cars | My Saved Cars [Save car](#)



### List It for Sale

Reach millions of in-market shoppers on KBB.com and AutoTrader.com.

[Place your ad](#)

## Free Dealer Price Quote

Get the best price and be more prepared with your free, no-obligation price quote

ZIP Code

[Get your quote](#)

Advertisement

[Why ads?](#)

Search:

#### Popular Topics

- [New Cars for 2015](#)
- [Used Cars](#)
- [Car Classifieds](#)
- [Best Resale Value Awards](#)
- [5-Year Cost to Own Awards](#)

#### Car Reviews & News

- [Car Reviews](#)
- [Car Videos](#)
- [Auto Shows](#)
- [Car News](#)
- [Best Cars](#)

#### Help

- [FAQ](#)
- [Site Help](#)
- [Find a New Car](#)
- [What's My Car Worth?](#)
- [KBB Mobile](#)

#### Company

- [About Us](#)
- [Contact Us](#)
- [Careers](#)
- [Corporate Information](#)

#### Industry Relations

- [Advertising](#)
- [Media Center](#)
- [Linking Policy](#)
- [Business Solutions](#)

Follow KBB

[Facebook](#)

[Twitter](#)

[Google+](#)

[YouTube](#)

[LinkedIn](#)

[RSS](#)

Mobile Apps

[iPhone](#)

[Android](#)

© 1995-2015 Kelley Blue Book Co., Inc. All rights reserved. [Copyright & Trademarks](#) | [Terms of Service](#) | [Privacy Policy](#) | [Ad Choices](#)

Have comments about our Blue Book Values? [Give us your feedback.](#)

© 2015 Kelley Blue Book Co., Inc. All rights reserved. 3/27/2015-4/2/2015 Edition for Texas 77084. The specific information required to determine the value for this particular vehicle was supplied by the person generating this report. Vehicle valuations are opinions and may vary from vehicle to vehicle. Actual valuations will vary based upon market conditions, specifications, vehicle condition or other particular circumstances pertinent to this particular vehicle or the transaction or the parties to the transaction. This report is intended for the individual use of the person generating this report only and shall not be sold or transmitted to another party. Kelley Blue Book assumes no responsibility for errors or omissions. (v.15040)











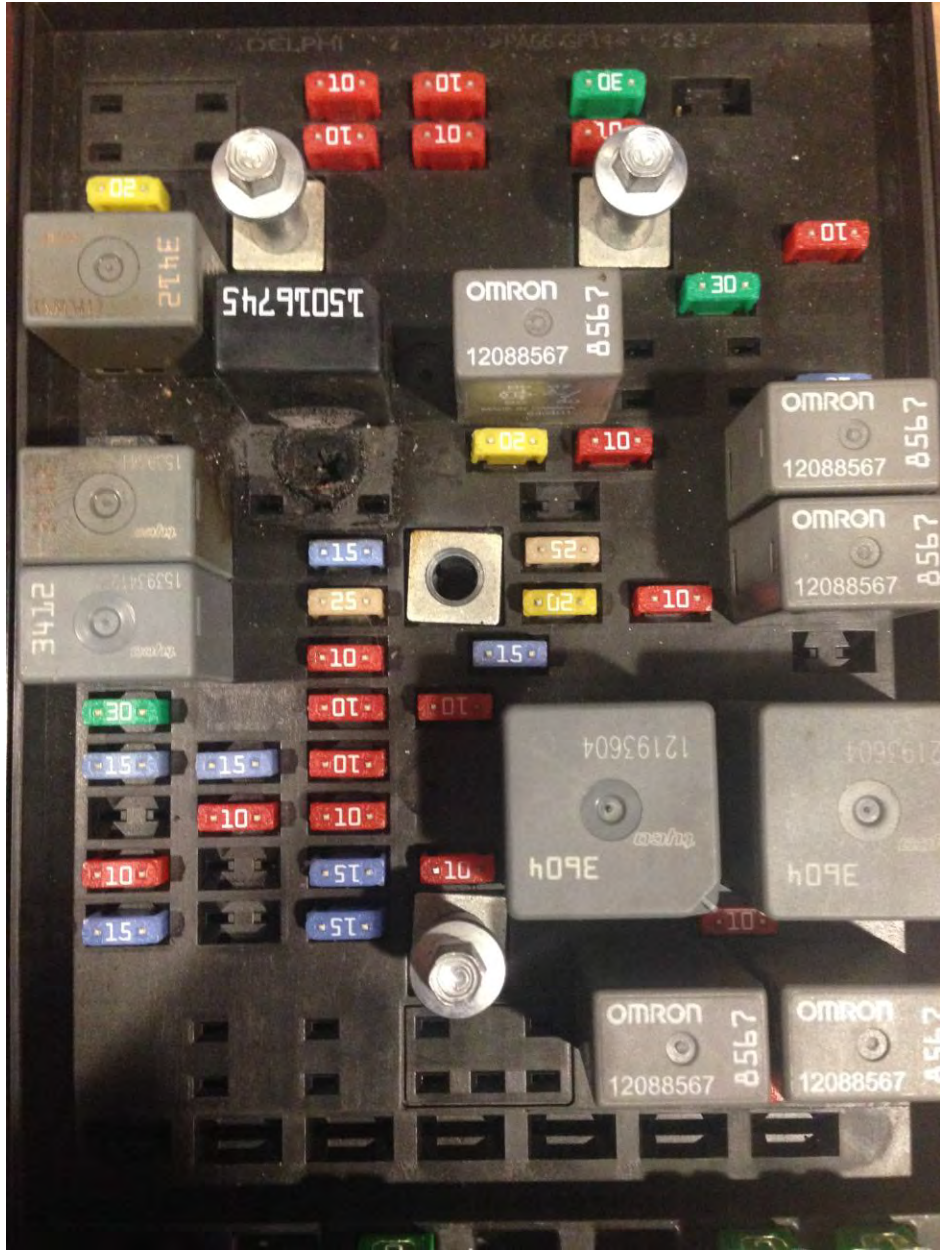

Product Assistance Center  
Preliminary Technical Consultant Report

Date: 3/27/2015

VIN: 1GNDS13S97 [REDACTED]

SR #: [REDACTED] 8

Customer Name: Dombrowski Luke

Case Matter # [REDACTED]

PAC Advisor: Nancy Novak

Report/Recommendation:

Based upon available information, the customer's statements, and photos, it appears that the origin of the fire is consistent with field action 14291. 14291 is not associated with this vehicle. The customer stated the incident occurred on 3/17/2015 and the vehicle mileage is stated as 120,000.

Based on the available information, it is recommended that the vehicle be repurchased or repaired as appropriate.

If any additional information becomes available, this report may be revised.

Mickey Sabol  
PAC Technical Consultant

Type of case	Melt Case	Case Summary
Status	New	Allegation;both headlights went out at once, it melted the fuse box and relay and I think that my car has a recall for this 3/27/15-Photolog attached to Siebel SR
SR Number	[REDACTED]	
Customer Name (Last name/First Name)	[REDACTED]	
Year/Make/Model	2007/Chevrolet/Trailblazer	
VIN	1GNDS13S9 [REDACTED]	
Incident Date	2/17/2015	
Purchase Date	3/1/2008	
Titled in who's name	[REDACTED]	
Purchase Price	Unknown	
Open/Closed Recalls (If closed include closed Transaction History)	<i>Product Safety Recall N140309 14309 DRIVER DOOR SWITCH SHORT CIRCUIT 11/05/2014 Open</i> <i>Product Safety Recall N120180 12180 DRIVER DOOR SWITCH SHORT CIRCUIT 02/18/2013 Closed</i>	
Mileage	124,000	
Purchased From	GM Dealer in Florida	
Vehicle Insured	No	
MSRP/KBB (Trade-in Good Value)	5723.00	

Loaner Vehicle (yes/no from drop down and enter date issued)	No		
Additional Information as requested by TC/TL			

Type of case	Fire Case	Case Summary
Status	Closed	<p>Allegation; Customer advised that on 3/17/2015 that his headlamps were not turning off while the vehicle was off. Customer advised that he lifted the hood and smelled a burning smell so he checked the fuse box and the headlamp relay was on fire. Customer advised that he put out the fire and on 3/18/2015 he repaired the vehicle and is still making repairs. Customer advised that he is not looking to file a claim . He is just wanted to report the issue to GM to alert them to a potential issue.</p> <p>CRS thanked customer for the information and advised that we submit the details to our engineering team for internal review. Case closed.</p>
SR Number	[REDACTED]	
Customer Name (Last name/First Name)	[REDACTED]	
Year/Make/Model	2003 Chevrolet Trailblazer	
VIN	1GNES16SX3 [REDACTED]	
Incident Date	3/17/2015	
Purchase Date	6/1/2008	
Titled in who's name	[REDACTED]	
Purchase Price	n/a	
Open/Closed Recalls (If closed include closed Transaction History)	<p><i>Product Safety Recall N040087 04087 TAIL LAMPS/STOP LAMPS 11/16/2004 Closed</i></p> <p><i>Product Safety Recall N040005 04005 WINDSHIELD WIPER MOTOR FAILURE 07/06/2004 Closed.</i></p>	
Mileage	193,613	
Purchased From	n/a	
Vehicle Insured	Yes	
MSRP/KBB (Trade-in Good Value)	\$2,290.00	

Loaner Vehicle (yes/no from drop down and enter date issued)	No		
Additional Information as requested by TC/TL			

Type of case	Fire Case	Case Summary
Status	Closed	<p>Allegation; Customer alleged the vehicle would have lasted longer if not for the fire in the fuse box assembly. Customer seeks to inform GMC about the fire.</p> <p>Customer has made an insurance claim.</p> <p>Closing file, customer satisfied.</p>
SR Number	[REDACTED]	
Customer Name (Last name/First Name)	[REDACTED]	
Year/Make/Model	2003, GMC, Envoy	
VIN	1GKDT13S832 [REDACTED]	
Incident Date	3/4/2015	
Purchase Date	9/2/2003	
Titled in who's name	customer's name	
Purchase Price	unknown	
Open/Closed Recalls (If closed include closed Transaction History)	<p><i>Product Safety Recall N040087 04087 TAIL LAMPS/STOP LAMPS 11/16/2004 Closed, 06/21/2005 154301 ZFAT----Field Action Recall V1265 - 04087 - Inspect and Replace One or Both Tail Lamp Circuit Boards and Lamps 61,628 MI</i></p> <p><i>Noncompliance Recall N030039 03039 CHILD RESTRAINT ANCHORAGE SYSTEM INFORMATION 08/11/2003 Closed, 08/27/2003 273197 ZFAT----Field Action Recall Add Credit V1043 - 03039 - COPY AND PLACE SUPPLEMENT IN THE OWNERS MANUAL 3 MI</i></p> <p><i>Special Coverages: 04017, 07076</i></p>	
Mileage	300,000	
Purchased From	dealership	
Vehicle Insured	Yes	

MSRP/KBB (Trade-in Good Value)	\$2,146.00	
Loaner Vehicle (yes/no from drop down and enter date issued)	No	
Additional Information as requested by TC/TL		





























Product Assistance Center  
Preliminary Technical Consultant Report

Date: 4/29/2015

VIN: 1GNDDT13S07222 [REDACTED]

SR #: 7 [REDACTED]

Customer Name: [REDACTED]

Case Matter #: 8 [REDACTED] 0

PAC Advisor: Denan Selimovic

Report/Recommendation:

Based upon available information, the customer's statements, and photos, it appears that the origin of the fire is consistent with field action 14291. 14291 is not associated with this vehicle. The customer stated the incident occurred on 4/7/2015 and the vehicle mileage is stated as 75,000.

Based on the available information, it is recommended that the vehicle be repurchased or repaired as appropriate.

If any additional information becomes available, this report may be revised.

Mickey Sabol  
PAC Technical Consultant

Denan Selimovic (C)

---

From: Denan Selimovic (C)  
Sent: Wednesday, April 29, 2015 5:32 PM  
To: 'klined1@autonation.com'  
Subject: Repair estimate for 2007 Chevrolet Trailblazer

Hey Derek,

Please provide us with a repair estimate for headlamp relay replacement and any other damages that might have been caused by headlamp relay catching on fire.

You can attach the repair estimate to this email.

Based upon available information and customer's statements, and photos, it appears that the origin of fire is consistent with field action 14291.

The customer information is:

Customer Name: [REDACTED]

Customer Phone [REDACTED]

Vehicle: 2007, Chevrolet, TrailBlazer

SR Number: [REDACTED]

VIN: 1GNDT13S07 [REDACTED]

Please call me if you have any questions.

**Denan Selimovic**

General Motors Business Resource Center  
Product Assistance Claims  
(866) 446-6963 ext. 11834

(866) 508-1973 (fax)

[denan.selimovic@gm.com](mailto:denan.selimovic@gm.com)



Customer And Relationship Services

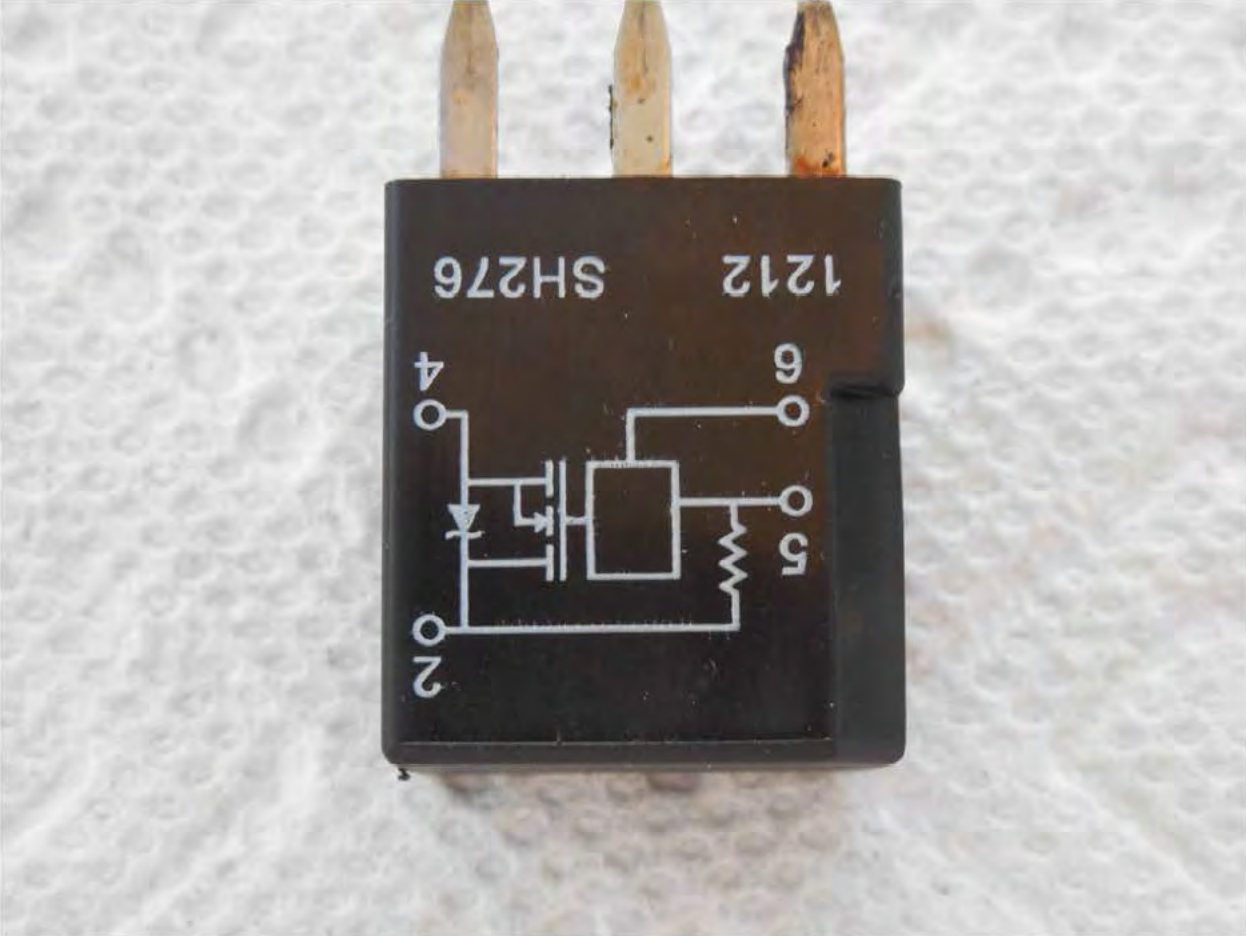

















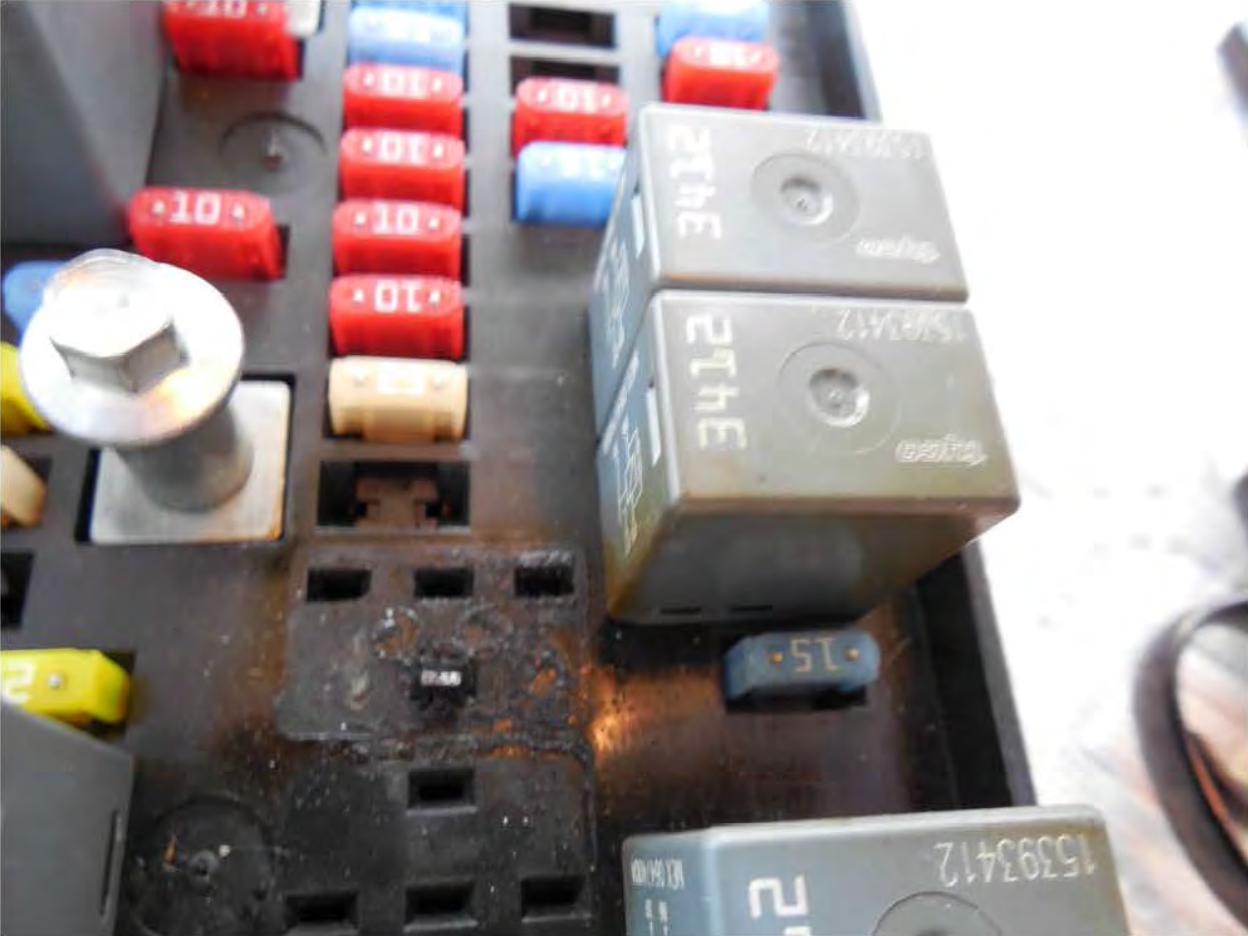

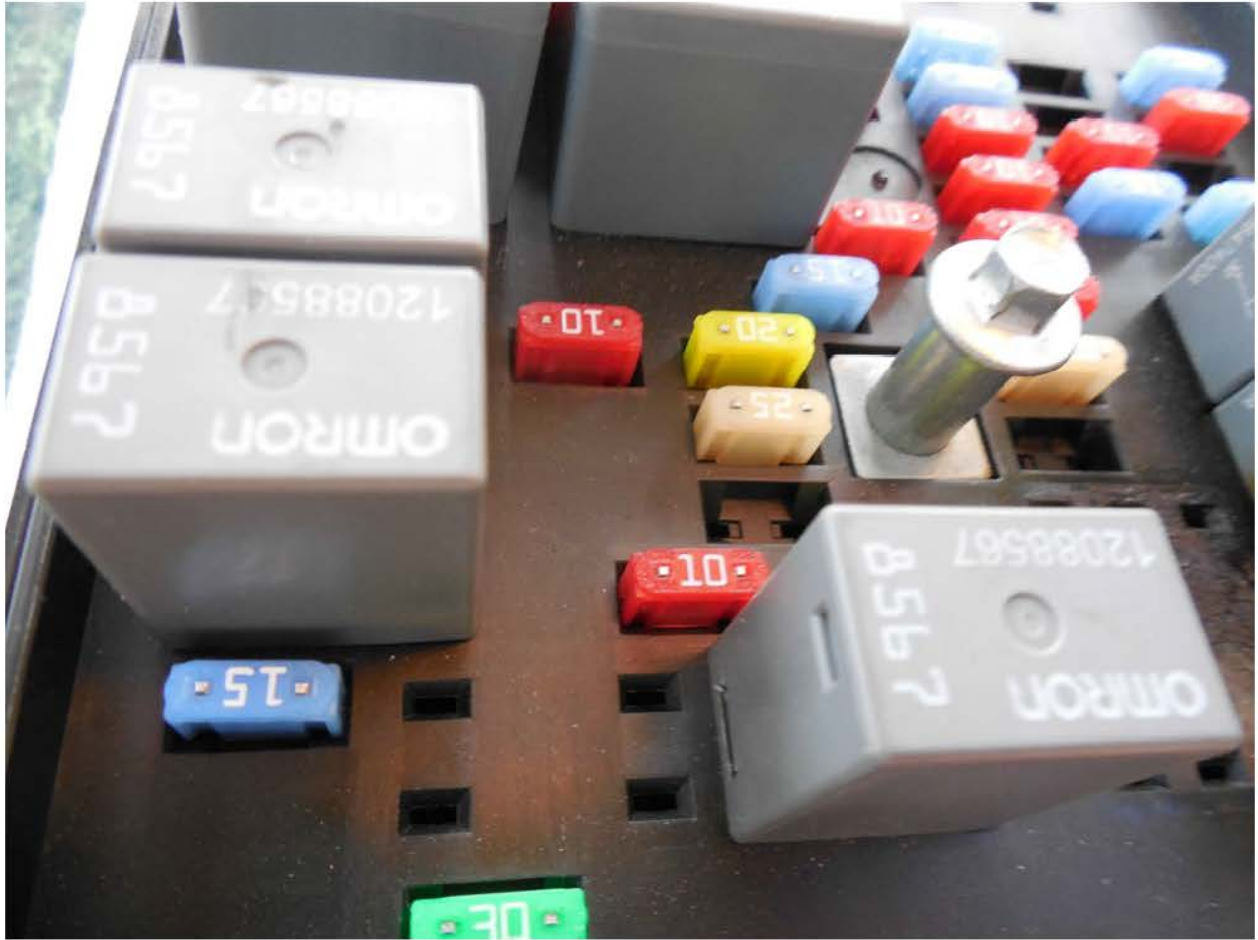







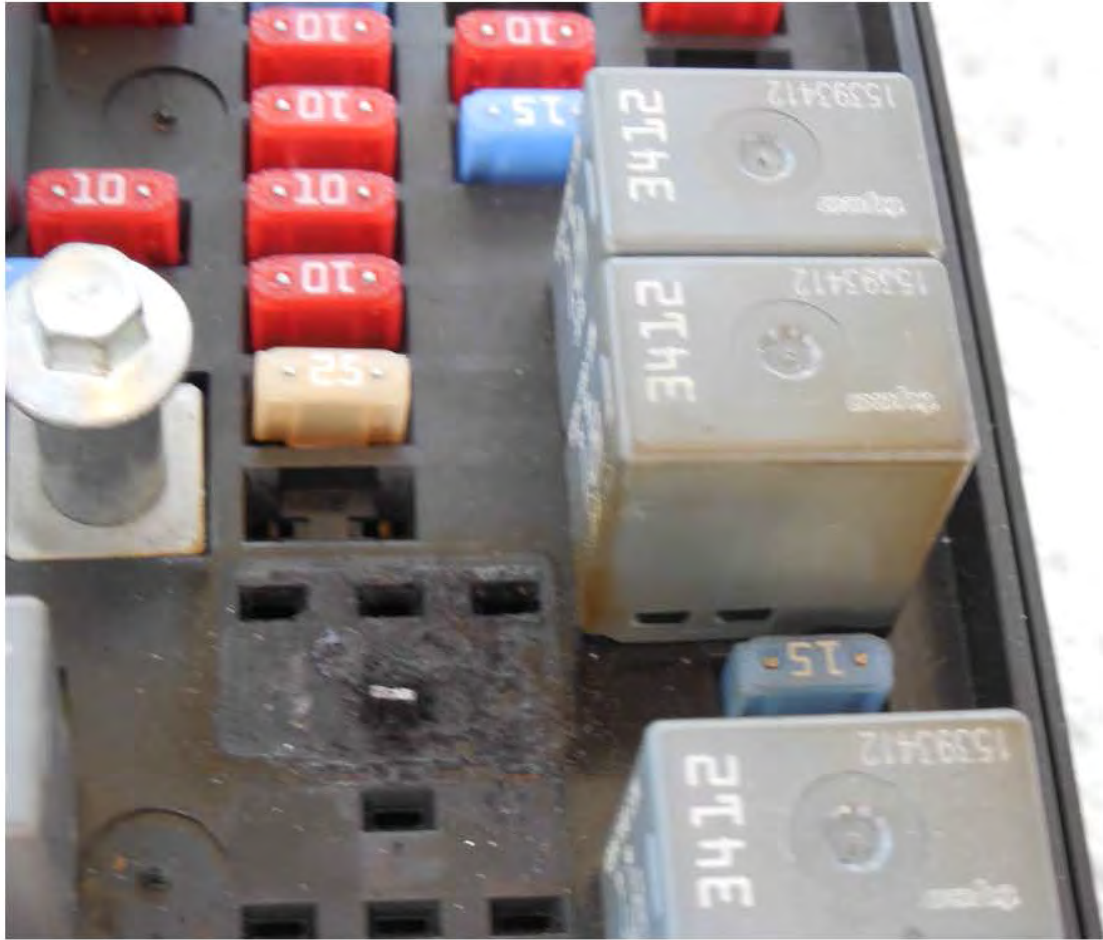

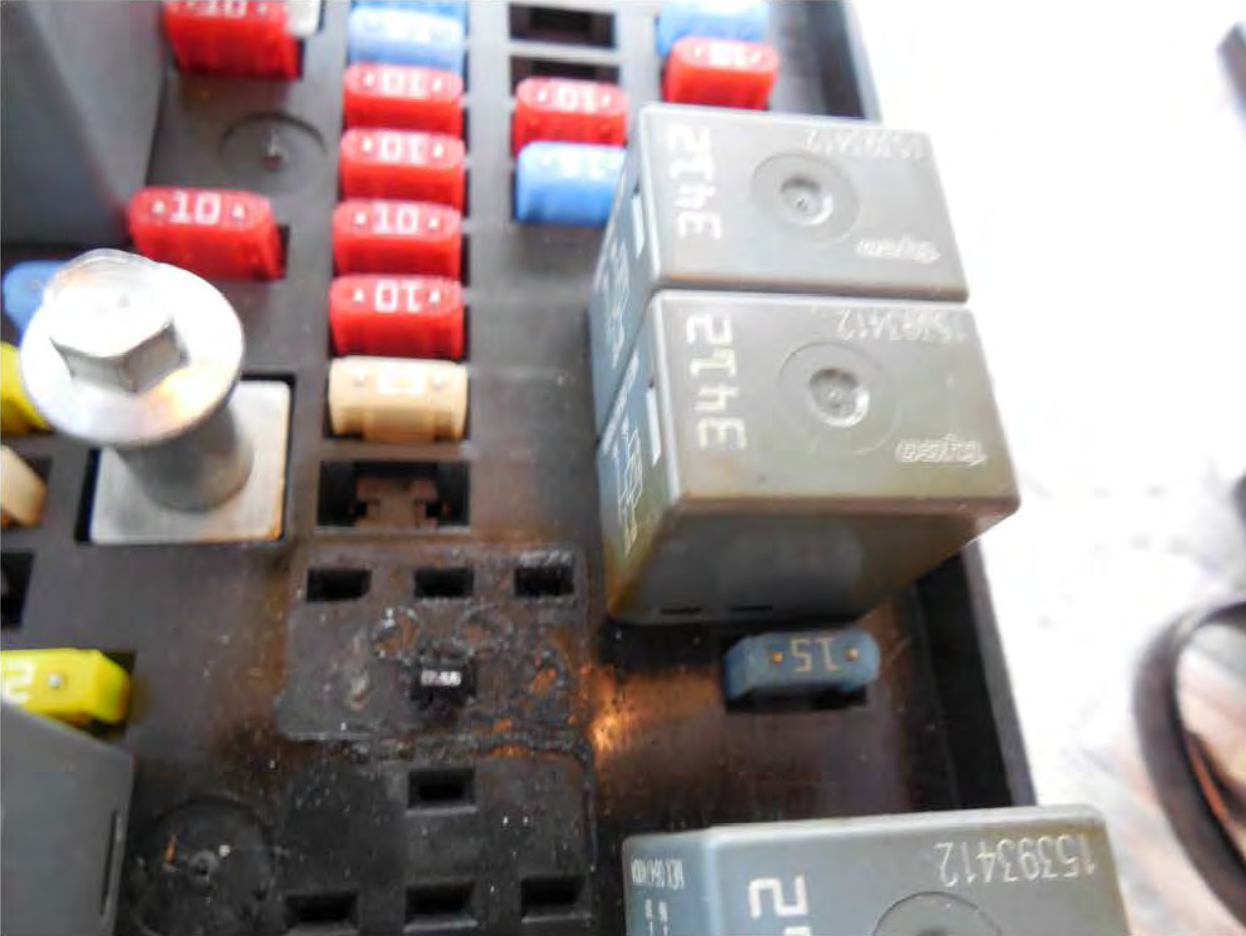

Denan Selimovic (C)

---

From: Giddings, Josh <GiddingsJ@autonation.com>  
Sent: Friday, May 01, 2015 3:23 PM  
To: Denan Selimovic (C)  
Subject: Don Olsen; 2007 Chevrolet Trailblazer

Good evening,

I received the estimate regarding Mr. Olsen's vehicle, it will need a new fuse block.

Parts= \$298.37  
Labor= \$235.98  
Tax= \$17.90

Total= \$552.25

Joshua Giddings  
AutoNation, Inc.  
Laurel, MD 20707  
301-483-7802

CONFIDENTIAL: This electronic mail (including any attachments) may contain information that is privileged, confidential, and/or otherwise protected from disclosure to anyone other than its intended recipient(s). Any dissemination or use of this electronic email or its contents (including any attachments) by persons other than the intended recipient(s) is strictly prohibited. If you have received this message in error, please notify us immediately by reply email so

that we may correct our internal records. Please then delete the original message (including any attachments) in its entirety. Thank you



Close Window

# Edit Transaction Pre-Repair Authorization

PRINT-FRIENDLY VERSION |

This screen allows the user to edit existing Pre-Repair Authorization.

Business Unit\*: GM - US

Transaction Type\*: ZREG—Regular Vehicle Transaction

Pre-Repair Type: Repair Authorization

## Pre-Repair Authorization

Pre-Repair Auth ID:

Original Author: Erica Jesse

New Author: Erica Jesse

\*Required Fields  
Disclaimer: All amounts are before taxes

BAC\*: 118112

Service Agent: AUTONATION BUICK GMC LAUREL

Contact Name: Derek Kline

Phone Number: 3017252700

Fax Number:

Contact Email Address: klined1@autonation.com

Job Card\*: 386068

Job Card Date: 05/11/2015

Reference Number:

VIN: 1GNDT13S072 [Investigate Vehicle History](#)

Odometer: 77609

- Transaction Flag:
- Customer Enthusiasm - Non Warrantable Repair
  - Special Coverage
  - Policy
  - None

Customer Complaint Category\*: 09—No Customer Complaint

Complaint Code\*: 0090—No Customer Complaint - Other issues

Description\*: No customer complaint-Other issues

Cause Code\*:

9090 , Other - Field Action / Tech Bulletin

Description: \* Other-Field Action/Tech Bulletin

Correction Description: \* Repair Vehicle

Labour Operation\*: 0600006

Labour Time: 2 Supp Time: 0 OLH Time: 0

Labour Rate: 99.02 Common GM Division - Mechanical

Labour Total: 198.04

Parts Total: 298.37

Part Numbers:

Net Item Type Amount

<Make Selection> + -

Net Item Total: 0.00

Tax: 0

Deductible: 0

Total Before Taxes: 496.41

Auth Code:

Accept  Reject

Comment:

Created By	Create Date/Time	Comment
Erica Jesse	Tue May 12 14:35:15 EDT 2015	Please include Pre Auth ID when you submit your claim.

Reassign Comments:	Created By	Comment	From	Assigned To
--------------------	------------	---------	------	-------------

Attachments:

No rows were found.

Attachment Id	Attachment Name	User Name
[Empty Row]		
<input type="button" value="Browse..."/>		<input type="button" value="ADD"/>
<input type="button" value="DELETE"/>		

Pre Repair Authorization History:

VIN	Pre-Repair Authorization ID	Create Date
1GNDT13S07[Redacted]	278145800000	2015-05-12

CUSTOMER #:

# AutoNation

AutoNation Chevrolet Laurel

\*WARRANTY\*

501 WASHINGTON BLVD.  
LAUREL, MD 20707  
(301) 725-2700

DUPLICATE 1  
PAGE 1

6384 BARKER ST  
COLUMBIA, MD 21047  
HOME: [REDACTED]  
BUS: [REDACTED]

SERVICE ADVISOR: 4279 JOSH GIDDINGS

COLOR	YEAR	MAKE/MODEL	VIN	LICENSE	MILEAGE IN / OUT	TAG	
	07	CHEVROLET TRAILBLAZE	1GNDT13S07		77609/77609		
DEL. DATE	PROD. DATE	WARR. EXP.	PROMISED	PO NO.	RATE	PAYMENT	INV. DATE
01JAN07 DE		01JAN2010	17:00 30APR15			CASH	11MAY15
R.O. OPENED	READY	OPTIONS:					
16:09 30APR15	15:35 11MAY15	DLR:14021 ENG:4.2_Liter_DOHC					

LINE	OPCODE	TECH	TYPE	HOURS	LIST	NET	TOTAL
------	--------	------	------	-------	------	-----	-------

A CUSTOMER STATES-PROVIDE ESTIMATE ON HEADLAMP RELAY REPLACEMENT AND THE DAMAGE CAUSED BY THE HEADLAMPY RELAY CATCHING ON FIRE-RECALL IS CONSISTANT WITH ISSUE-RECALL #14291-  
 BY001 CUSTOMER STATES-PROVIDE ESTIMATE ON HEADLAMP RELAY REPLACEMENT AND THE DAMAGE CAUSED BY THE HEADLAMPY RELAY CATCHING ON FIRE-RECALL IS CONSISTANT WITH ISSUE-RECALL #14291-OKD REPAIR AUTHORIZED BY PRODUCT ASSISTANCE CLAIMS -D. SELIMOVIC(ATTACHED)  
 2685 WCT 2.00 235.98 235.98  
 1 25790683 2483 (\$)BLOCK 298.37 298.37 298.37  
 16128 29837 TPARTS  
 6200 23598 TLABOR

SALE-LBR: 235.98 PTS: 298.37 MSC: 0.00 LUB: 0.00 SUB: 0.00 TOTAL 534.35

\*\*\*\*\*

Dealer is not authorized to perform recall repairs for non-Dealer brand vehicles and Dealer's Vehicle Safety and Condition inspection and/or service does not include a review of possible pending recalls or service campaigns issued by manufacturers of other makes and models.

SALE-LBR: 235.98 PTS: 298.37 MSC: 0.00 LUB: 0.00 SUB: 0.00 TOTAL 534.35

DATE	START	FINISH	DURATION	TYPE	TECH	LINE(S)	CHG
05-01-15	14:52	15:42	0.83	W	2685	A	

COST, SALE, & COMP TOTALS 22328 53435 0

OUR OTHER LOCATIONS		LIMITED WARRANTY	DESCRIPTION	TOTALS
AutoNation Chevrolet Security Blvd. 6633 SECURITY BLVD. BALTIMORE, MD 21207 (410) 285-7777	AutoNation Chevrolet Timonium 60 E. PADONIA RD. TIMONIUM, MD 21093 (410) 667-6666	THIS INVOICE MUST ACCOMPANY ANY AND ALL ADJUSTMENTS OR CLAIMS. CLAIMS MUST BE MADE WITHIN 90 DAYS OR 4000 MILES WHICHEVER OCCURS FIRST. YOUR SPECIFIC WARRANTY MAY VARY. SEE SERVICE ADVISOR RO DETAILS.	LABOR AMOUNT	235.98
			PARTS AMOUNT	298.37
			GAS, OIL, LUBE	0.00
			SUBLET AMOUNT	0.00
			MISC. CHARGES	0.00
			TOTAL CHARGES	534.35
			LESS INSURANCE	0.00
			SALES TAX	0.00
CASH ( ) VISA/MC ( ) DISCOVER ( ) AMEX ( ) PERSONAL CHECK ( ) CHK# ( ) MOST ( ) INS CHECK ( ) CHK# ( ) COMP. CHK# ( ) CHK# ( )		CUSTOMER SIGNATURE	PLEASE PAY THIS AMOUNT	534.35

**Denan Selimovic (C)**

---

**From:** Mickey Sabol  
**Sent:** Wednesday, April 29, 2015 2:27 PM  
**To:** Denan Selimovic (C)  
**Cc:** Kimberly Horvath (C)  
**Subject:** FW: Update - Fire Case SR# [REDACTED]

Hi Denan,

Just as an FYI – the Engineering Team has already reviewed the photos. The HDM relay is an aftermarket part so the customer is either very forgetful or lying. It doesn't matter to the TCR but I wanted you to be aware.

Mickey

---

**From:** Mickey Sabol  
**Sent:** Wednesday, April 29, 2015 12:39 PM  
**To:** Jeffrey Calderas  
**Subject:** FW: Update - Fire Case SR# [REDACTED]

FYI – from below

Customer stated that he bought his vehicle brand new, and he never replaced HDM relay for the low beam headlamps. Customer also stated that he never replaced DRL on his vehicle.

---

**From:** Denan Selimovic (C)  
**Sent:** Wednesday, April 29, 2015 11:54 AM  
**To:** Mickey Sabol  
**Cc:** Kimberly Horvath (C)  
**Subject:** Update - Fire Case SR# [REDACTED]

Type of case	Fire Case	Case Summary
Status	Update	Customer alleged that his wife was driving

SR Number	[REDACTED]	
Customer Name (Last name/First Name)	[REDACTED]	
Year/Make/Model	2007, Chevrolet, TrailBlazer	
VIN	1GNDT13S0722 [REDACTED]	
Incident Date	4/7/2015	
Purchase Date	10/1/2007	
Titled in who's name	[REDACTED]	
Purchase Price	\$27,000	
Open/Closed Recalls (If closed include closed Transaction History)	<i>DRIVER DOOR SWITCH SHORT CIRCUIT V2739-12180 - Functional Test and Verify Part Number - No Further Action Req'd (Closed</i>	
Mileage	75,000	
Purchased From	Koons Chevrolet, Inc. 10207 Philadelphia, White Marsh, MD	
Vehicle Insured	Yes	
MSRP/KBB (Trade-in Good Value)	\$6,780.00	
Loaner Vehicle (yes/no from drop down and enter date issued)	No	

the vehicle, and she noticed that headlights were not working. When customer's wife came home, there was a burning plastic smell coming from the vehicle. Therefore, customer took the vehicle to Computerized Car Care on 9225 Berger Rd, Columbia, MD., and was informed that the main relay for headlights had caught on fire, and the only reason the whole vehicle didn't burn down is because the headlamp relay is enclosed in a plastic cover and there wasn't enough oxygen to keep the flame burning. Customer believes that the headlamp relay caught on fire due to a defect with the headlamp relay.

Photos of the vehicle and headlamp relay are attached in Siebel.

Additional Information as requested by TC/TL

Customer stated that he bought his vehicle brand new, and he never replaced HDM relay for the low beam headlamps. Customer also stated that he never replaced DRL on his vehicle.

Additional photos requested of the relay are attached in Siebel.

**Denan Selimovic**

General Motors Business Resource Center

Product Assistance Claims

(866) 446-6963 ext. 11834

(866) 508-1973 (fax)

[denan.selimovic@gm.com](mailto:denan.selimovic@gm.com)



Customer And Relationship Services

Denan Selimovic (C)

---

From: Denan Selimovic (C)  
Sent: Wednesday, May 13, 2015 9:22 AM  
To: 'klined1@autonation.com'  
Subject: Subject: Pre-Repair Authorization ID for payment using labor op 0600006

Upon receipt of this pre-authorization for the above listed claim for payment, please verify that the information listed below is correct. Please make sure that it is the correct customer, VIN, mileage, BAC, Job Card#, Job Card close date and dollar amount.

If everything is correct, please submit a "Pre Authorization Claim" (NOT a GM Authorization claim). The system will then prompt the Service Agent to enter the Pre-Repair Authorization ID and list all of the associated part numbers, labor hours, and other expenses that may have been approved. Please utilize the appropriate Net item types as applicable (Car Rental/Hire, Towing, Sublet, etc). The pre-authorization # is listed below. If this claim rejects, please contact the Warranty Support Center at 1-866-446-5900.

Servicing Dealer BAC 118112

Dealer Contact Service Manager Derek Kline

Dealer Email [klined1@autonation.com](mailto:klined1@autonation.com)

Dealer Fax

Job Card number



Job Card Date 05/11/2015

VIN 1GNDT13S072



Odometer 77609

Labor Op 0600006

Labor Time (hrs) estimate 2

Dealer's mechanical warranty rate per hour 117.99

Total Labor Estimate 235.98

Parts total 298.37

Car Rental/Hire (if applicable) 0

Sublet (if applicable) 0

Claim total 534.35

Customer Compliant Category: 09

Complaint Code: 0090

Description: No customer complaint-Other issues

Cause Code: 9090

Description: Other-Field Action/Tech Bulletin

Correction Description: Repair Vehicle

\*\* Labor Rate in Template does not Match Labor Rate in GWM. GWM Labor rate is \$99.02

\*\*

Line Before Tax: \$496.41

Pre Authorization ID: 278145800000

Approved/Rejected: Approved

Date Entered: 5/12/15

Entered By: Erica Jesse

PAC CRS: Denan

If you have any other questions, please contact me

General Motors

Product Assistance Claims

**Denan Selimovic**

General Motors Business Resource Center

Product Assistance Claims

(866) 446-6963 ext. 11834

(866) 508-1973 (fax)

[denan.selimovic@gm.com](mailto:denan.selimovic@gm.com)



**Customer**

[REDACTED]  
[REDACTED]

**Vehicle**

2007 GMC Envoy  
1GKDT13S4722 [REDACTED]  
Mileage now: 167000 mi

**Status of vehicle/concern**

A GM Dealer has diagnosed the current concern  
Repairs have not been scheduled

**Key Points**

Seeking repair for headlamps. Customer stated she was advised that the headlamps cannot be replaced or repaired because there is no bulletin released. Customer is seeking gas gauge repair as well.

Supporting Factors	Limiting Factors
	Vehicle is > 8 years old (verified) Vehicle has > 100,000 miles
<p><i>Please consider these additional questions:</i>                      Close to any applicable expiration limit? (wrnty, spl covg, svc contrt)                      Did cust buy an extd svc contract, but it's expired or n/a?                      Is this a loyal service customer? (to involved dealer)                      Are high dollar customer-pay ROs on record for this cust?                      Is this a conquest buyer?</p>	<p><i>Please consider these additional questions:</i>                      Is vehicle way beyond all applicable expiration limits?                      Does veh have an active <u>aftermarket</u> Extd Svc Contract?                      Did customer buy vehicle outside of warranty?                      Does it seem customer doesn't take care of the vehicle?                      Is cause not normally covered by warranty?                      Is cause due to an accident insurance won't cover?                      Is cause due to damage by independent repair facility?</p>

**Additional key points**

[REDACTED]  
[REDACTED]

CAC advisor: Joe--> (866) 790-5700, Ext # 41570



AGREEMENT NUMBER

[REDACTED]
------------

**CUSTOMER INFORMATION**

CUSTOMER'S NAME [REDACTED]			
CUSTOMER'S STREET ADDRESS [REDACTED]		CITY Lakeside Marblehead	
STATE OH	ZIP CODE [REDACTED]	CUSTOMER'S PHONE [REDACTED]	CUSTOMER'S EMAIL ADDRESS [REDACTED]
YEAR 2009	MAKE GMC	MODEL ENVOY SLT	VEHICLE IDENTIFICATION NUMBER 1GKDT43S7 [REDACTED]
ODOMETER READING [REDACTED]	AGREEMENT PURCHASE DATE 5/26/2015	VEHICLE IN-SERVICE DATE 8/26/2014	SALESPERSON NAME
SELLING DEALER NAME General Motors Customer Assistance		ADDRESS 100 Renaissance Center Drive	
CITY Detroit	STATE MI	ZIP CODE [REDACTED]	FAX NUMBER [REDACTED]
LIENHOLDER (NEEDED ONLY WHEN AGREEMENT IS INCLUDED WITH VEHICLE FINANCING)			

**PROGRAM INFORMATION**

AGREEMENT TERM: 18 MONTHS 15000 MILES                      AGREEMENT COST: \$ 320

YOUR AGREEMENT EXPIRES ON 12/24/2016  
 OR WHEN YOUR VEHICLE'S ODOMETER READS 58982  
 OR WHEN ALL SERVICES LISTED ON THE VEHICLE MAINTENANCE  
 SERVICES CHECKLIST HAVE BEEN REDEEMED  
 (WHICHEVER OCCURS FIRST)

MAINTENANCE PACKAGE
PPMPlus

SERVICES SCHEDULE
Normal Schedule1

**ACKNOWLEDGEMENT**

Purchaser acknowledges that the service must be performed at the **Selling Chevrolet, Buick, GMC, Cadillac Dealer** or any Chevrolet, Buick, GMC, Cadillac dealer. Purchase of this Pre-Paid Vehicle Maintenance **Agreement** is not required in order to obtain **Vehicle** financing. Incidental or consequential damage or loss caused by breakdown of components (or otherwise) including property damage, personal injury, inconvenience, loss of vehicle use, and/or commercial loss and punitive damage is expressly excluded.

CUSTOMER SIGNATURE \_\_\_\_\_

AUTHORIZED SELLING DEALER REPRESENTATIVE \_\_\_\_\_ DATE 5/26/2015

The definition of "**We, Us and Our**" used frequently throughout the Pre-Paid Vehicle Maintenance **Agreement** is defined as AMT Warranty Corp., P.O. Box 927, Bedford, TX 76095, (877) 265-1072. Please refer to the Pre-Paid Vehicle Maintenance **Agreement** for additional definitions.

**Our** obligations and the performance to **You** under this **Agreement** are guaranteed and insured by a policy issued by Wesco Insurance Company (a California approved Insurance Company), 59 Maiden Lane, 43rd Floor, New York, NY 10038, (877) 528-7878. If a covered service is not paid within sixty (60) days (except Arizona thirty (30) days) after proof of maintenance has been filed, **You** may file a claim directly with Wesco Insurance Company. Please call (866) 505-4048 for instructions.

**Florida residents**, the Pre-Paid Vehicle Maintenance **Agreement** Obligor/Provider and **Administrator** is WESCO INSURANCE COMPANY, 59 Maiden Lane, 43rd Floor, New York, NY 10038, (866) 327-5818, LICENSE #01913.

# PRE-PAID VEHICLE MAINTENANCE AGREEMENT

## DEFINITIONS

The following definitions apply to words frequently used in this Pre-Paid Vehicle Maintenance Agreement and appear in **Bold Faced Type**:

**Agreement** – Means this Pre-Paid Vehicle Maintenance Agreement which You have purchased from Us.

**You, Your** – Means the customer identified on the Registration Page.

**We, Us, Our** – Means the party obligated to fulfill the services of this Agreement, as shown on the Registration Page.

**Administrator** – Means AMT Warranty Corp., P.O. Box 927, Bedford, TX 76095, (877) 265-1072, unless otherwise stated on the Registration Page.

**Registration Page** – Means Page 1 of this Agreement that identified information about You, the Selling Chevrolet, Buick, GMC, Cadillac Dealer, the Agreement Term and the covered Vehicle.

**Selling Chevrolet, Buick, GMC, Cadillac Dealer** – Means the authorized dealer from whom You purchased the Vehicle described on the Registration Page and who sold You this Agreement.

**Maintenance Package** – Means the list of services purchased by You for Your Vehicle as stated in this Agreement and as shown on the Registration Page.

**Vehicle** – Means the Vehicle described on the Registration Page.

## COVERAGE TERMS

THIS PRE-PAID VEHICLE MAINTENANCE AGREEMENT IS BETWEEN YOU AND US. ALL AGREEMENT SERVICES WILL BE PERFORMED BY AND PAID FOR BY THE SELLING OR ANY CHEVROLET, BUICK, GMC, CADILLAC DEALER. THIS AGREEMENT IS NOT AN INSURANCE POLICY, NOR SHOULD ANYTHING WITHIN THIS AGREEMENT BE CONSTRUED AS AN AGREEMENT TO PROVIDE INSURANCE.

Your Vehicle may require additional services that are not provided under this Agreement. Please refer to Your Vehicle's owner's manual for recommended services and intervals.

1. This Agreement is valid only for the Vehicle identified on the Registration Page.
2. The services provided in the Maintenance Package under this Agreement are available only at the Selling Chevrolet, Buick, GMC, Cadillac Dealer or any authorized Chevrolet, Buick, GMC, Cadillac dealer.
3. Parts, oil, fluids and lubricants used shall not deviate from quality types or quantities used by the manufacturer when the Vehicle was delivered new.
4. Genuine AC Delco / GM parts will be used where applicable unless otherwise authorized by You.
5. Shop and environmental fees are included.

## WHAT IS COVERED

### MAINTENANCE PACKAGES

PREPAID MAINTENANCE	PREPAID MAINTENANCE PLUS
Engine Oil & Filter Change *Tire Rotation	Engine Oil & Filter Change *Tire Rotation  See Vehicle Maintenance Services Checklist herein for additional items included in your purchase. The Vehicle Maintenance Services Checklist contains each of the maintenance services included in your package. You are entitled only to those maintenance services based on the number of times they are listed.

\*Some vehicles are equipped with unidirectional tires that cannot be rotated. These vehicles will not be charged for Tire Rotation maintenance services.

### SERVICES SCHEDULES

Engine Oil, Filter Change and Tire Rotation services listed in the Maintenance Package selected are recommended based on the Schedule shown on the Registration Page as follows:

**SCHEDULE 1:** 2 services for every 18 months or 15,000 miles.

**SCHEDULE 2:** 3 services for every 18 months or 15,000 miles.

**SCHEDULE 3:** 5 services for every 18 months or 15,000 miles.

**NOTE:** Many Vehicles are equipped with an engine oil life system that calculates engine oil life based on vehicle and, on most Vehicles, display a message when it is necessary to change the engine oil and filter.

## TERM OF PROGRAM

For Vehicles with manufacturer prepaid maintenance, Agreement expiration is measured in time from the Vehicle's in-service date and expiration mileage is reached when the Vehicle's odometer reaches the term miles shown on the Registration Page. Maintenance services provided by the manufacturer will not be reimbursed under the terms of this Agreement. The term of this Agreement runs concurrent with and may extend beyond the manufacturer prepaid maintenance based on the term selected.

For Vehicles that have not and/or do not have manufacturer prepaid maintenance, this Agreement begins on the Agreement Purchase Date and Odometer Mileage at Agreement Purchase Date. Expiration is measured in time from the Agreement Purchase Date and expiration mileage is derived by adding term miles as shown on the Registration Page to the Odometer Mileage at Agreement Purchase Date.

## DEALER STATUS

In the event that the Selling Chevrolet, Buick, GMC, Cadillac Dealer goes out of business or is unable to perform the services purchased, You may go to an alternate Chevrolet, Buick, GMC, Cadillac dealer. You may contact the Administrator for assistance in locating an alternate Chevrolet, Buick, GMC, Cadillac dealer to perform Your services. If the Administrator is unable to locate such a facility then We will reimburse You, the customer, reasonable and customary charges for services once proof of service has been received. Proof of service must be in the form of a receipt from a licensed service facility.

## TRANSFER OF YOUR AGREEMENT

- a. **Your Agreement** is transferable to the person **You** sell or otherwise transfer **Your Vehicle** to while this **Agreement** is still in force. This **Agreement** cannot be transferred if the title transfer of **Your Vehicle** passes through an entity other than the subsequent buyer, or **Your Vehicle** is sold or traded to a dealership, leasing agency or entity/individual in the business of selling vehicles. This **Agreement** can only be transferred once and the transfer must be made by the original **Agreement Holder**.
- b. To transfer, the following must be submitted to the **Administrator** within 30 days of the change of ownership to a subsequent individual purchaser:
  - A copy of **Your Registration Page**;
  - A completed transfer form; with
  - Name and Address of new owner, date of sale to new owner, current mileage; and
  - \$50.00 Transfer Fee (\$40.00 Florida Only) made payable to the **Administrator**.
- c. Any remaining manufacturer's warranty must also be transferred at the same time as **Vehicle** ownership transfer, if applicable.

## CANCELLATION OF YOUR AGREEMENT

- a. **You** may cancel this **Agreement** at any time, including when a loss of the **Vehicle** occurs or when **You** sell **Your Vehicle** without transfer of this **Agreement**. To cancel, **You** must submit a written request to the selling dealer or the **Administrator**. If **You** cancel this **Agreement**, it will not be reinstated. An odometer or notarized statement indicating the odometer reading on the date of the request will be required. This **Agreement** can only be cancelled by the original **Agreement Holder**.
- b. **We** may cancel this **Agreement** for non-payment of the **Agreement** cost, or for misrepresentation in the submission of a maintenance service redemption. **We** may cancel this **Agreement** if **Your Vehicle** is found to be modified in a manner not recommended by the manufacturer.
- c. If **Your Vehicle** and this **Agreement** have been financed, the lienholder shown on the **Registration Page** may cancel this **Agreement** for non-payment (except in the states of Utah, Washington and Wyoming), or if **Your Vehicle** is declared a total loss or is repossessed.
- d. If this **Agreement** is cancelled within the first sixty (60) days and no maintenance services have been redeemed, **We** will refund the entire **Agreement** cost paid. If this **Agreement** is cancelled after the first sixty (60) days or any maintenance services have been redeemed, **We** will refund an amount of the **Agreement** cost according to the pro-rata method reflecting the greater of the days in force or the miles driven based on the term/miles selected and the date coverage begins, less a fifty dollar (\$50.00) administrative fee and less any maintenance services redeemed. In the event of cancellation, the lienholder (if any) will be named on a cancellation refund check as their interest may appear.

## EXCLUSIONS

This **Agreement** will only cover those services listed under the **Maintenance Package** section based on the level selected that is indicated on the **Registration Page** of this **Agreement**. This **Agreement** does not cover any other maintenance items or services, nor will this **Agreement** pay for:

1. **Maintenance services performed by anyone other than the Selling or any Chevrolet, Buick, GMC, Cadillac dealer.**
2. **Any item not specifically listed on this Agreement for the Maintenance Package purchased as identified on the Registration Page and as detailed on the Vehicle Maintenance Services Checklist.**
3. **Any mechanical breakdowns, repairs, adjustments, alignments, improvements or upgrades of any kind.**
4. **Any costs You may incur for consequential or secondary damages; personal expenses; any parts, items, labor or fluids not listed.**
5. **Liability for damage to property or injury to, or death of any person arising out of the operation, maintenance, shipment, storage or use of the Vehicle whether or not related to the maintenance services or coverages.**
6. **Any maintenance services in excess of those provided by this Vehicle Maintenance Agreement.**

## LIMITS OF LIABILITY

The limit of **Our** liabilities is the services to which **You** would be entitled as listed herein and is the only remedy available to **You** not to exceed the term months/miles shown on the **Registration Page** as described in the Term of Program section of this **Agreement**. Services and related parts must be provided in accordance with the original manufacturer specifications.

## ARBITRATION PROVISIONS

**READ THE FOLLOWING ARBITRATION PROVISION ("PROVISION") CAREFULLY. IT LIMITS CERTAIN OF YOUR RIGHTS, INCLUDING YOUR RIGHT TO OBTAIN RELIEF OR DAMAGES THROUGH COURT ACTION.**

As used in this provision, "You" and "Your" means the person or persons named in this **Agreement**, and all of his/her heirs, survivors, assigns and representatives. And, "We" and "Us" shall mean the Obligor identified on the **Registration Page** and shall be deemed to include all of its agents, affiliates, predecessors in interest, successors and assigns, and any retailer or distributor of its products, and all of the dealers, licensees and employees of any of the foregoing entities.

**Please read this arbitration provision ("provision") carefully. It affects Your rights.**

Most customer concerns can be quickly and satisfactorily resolved by calling AMT Warranty Corp. at (877) 265-1072. **In the unlikely event that Your matter is not resolved or if We have been unable to resolve a dispute We have with You after attempting to do so informally, You and We each agree to resolve those disputes through binding arbitration or small claims court instead of in courts of general jurisdiction.** Arbitration is more informal than a lawsuit in court, it uses a neutral arbitrator instead of a judge or jury, it allows for more limited discovery than in court, and is subject to very limited review by courts. Arbitrators can award the same damages and relief as a court. **Any arbitration under this Agreement will take place on an individual basis; class arbitrations and class actions are not permitted. For any non-frivolous claim that does not exceed \$75,000, We will pay all costs of arbitration.** Moreover, in arbitration You are entitled to recover attorneys' fees to at least the same extent as You would in court. In addition, under certain circumstances (explained below), We will pay You more than the amount of the arbitrator's award and will pay Your attorney (if any) twice his/her reasonable attorneys' fees if the arbitrator awards You an amount that is greater than what We have offered You to settle the dispute.

- (1) We and You agree to arbitrate **all disputes and claims** that arise with respect to the other. This agreement to arbitrate is intended to be broadly interpreted. It includes, but is not limited to:
  - claims arising out of or relating to any aspect of the relationship, whether based in contract, tort, statute, fraud, misrepresentation or any other legal theory;
  - claims that arose before this or any prior contract (including, but not limited to, claims relating to marketing);
  - claims that are currently the subject of purported class action litigation in which You are not a member of a certified class; and
  - claims that may arise after the termination of this **Agreement**.

Notwithstanding the foregoing, either party may bring an individual action in small claims court. This arbitration agreement does not preclude You from bringing issues to the attention of federal, state, or local agencies. Such agencies can, if the law allows, seek relief against Us on Your behalf. **You agree that, by entering into this Agreement, You and We are each waiving the right to a trial by jury or to participate in a class action.** This **Agreement** evidences a transaction in interstate commerce, and thus the Federal Arbitration Act governs the interpretation and enforcement of this provision. This provision shall survive termination of the **Agreement**.

- (2) A party who intends to seek arbitration must first send to the other, by certified mail, a written notice of dispute ("Notice"). The Notice to Us should be addressed to: Legal Depart., AMT Warranty Corp., P.O. Box 927, Bedford, TX 76095 ("Notice Address"). The Notice must (a) describe the nature and basis of

the claim or dispute; and (b) set forth the specific relief sought ("Demand"). If We and You do not reach an agreement to resolve the claim within 30 days after Notice is received, You or We may commence an arbitration proceeding. During the arbitration, the amount of any settlement offer made by Us or You shall not be disclosed to the arbitrator until after the arbitrator determines the amount, if any, to which You or We is entitled. You may contact us to obtain a form to initiate arbitration.

- (3) After We receive notice at the Notice Address that You have commenced arbitration, We will promptly reimburse You for Your payment of the filing fee, unless Your claim is for greater than \$75,000. The arbitration will be governed by the Commercial Arbitration Rules and the Supplementary Procedures for Consumer Related Disputes (collectively, "AAA Rules") of the American Arbitration Association ("AAA"), as modified by this **Agreement**, and will be administered by the AAA. The AAA Rules are available online at [www.adr.org](http://www.adr.org), by calling the AAA at 1-800-778-7879, or by writing to the Notice Address. The arbitrator is bound by the terms of this **Agreement**. All issues are for the arbitrator to decide, except that issues relating to the scope and enforceability of the provision are for the court to decide. Unless We and You agree otherwise, any arbitration hearings will take place in the county of Your billing address. If Your claim is for \$10,000 or less, We agree that You may choose whether the arbitration will be conducted solely on the basis of documents submitted to the arbitrator, through a telephonic hearing, or by an in-person hearing as established by the AAA Rules. If Your claim exceeds \$10,000, the right to a hearing will be determined by the AAA Rules. Regardless of the manner in which the arbitration is conducted, the arbitrator shall issue a reasoned written decision sufficient to explain the essential findings and conclusions on which the award is based. Except as otherwise provided herein, We will pay all AAA filing, administration, and arbitrator fees for any arbitration initiated in accordance with the notice requirements above. If, however, the arbitrator finds that either the substance of Your claim or the relief sought in the Demand is frivolous or brought for an improper purpose (under the standards set forth in Federal Rule of Civil Procedure 11(b)), payment of all such fees will be governed by the AAA Rules. In such case, You agree to reimburse Us for all monies previously disbursed by Us that are otherwise Your obligation under the AAA Rules. In addition, if You initiate an arbitration in which you seek more than \$75,000 in damages, payment of these fees will be governed by the AAA rules.
- (4) If, after finding in Your favor in any respect on the merits of Your claim, the arbitrator issues You an award that is greater than the value of the last written settlement offer made by Us before an arbitrator was selected, We will:
- pay You the amount of the award or \$10,000 ("the alternative payment"), whichever is greater; and
  - pay Your attorney, if any, twice the amount of attorneys' fees, and reimburse any expenses (including expert witness fees and costs) that Your attorney reasonably accrues for investigating, preparing, and pursuing Your claim in arbitration ("the attorney premium").
- If We did not make a written offer to settle the dispute before an arbitrator was selected, You and Your attorney will be entitled to receive the alternative payment and the attorney premium, respectively, if the arbitrator awards You any relief on the merits. The arbitrator may make rulings and resolve disputes as to the payment and reimbursement of fees, expenses, and the alternative payment and the attorney premium at any time during the proceeding and upon request from either party made within 14 days of the arbitrator's ruling on the merits.
- (5) The right to attorneys' fees and expenses discussed in paragraph (4) supplements any right to attorneys' fees and expenses You may have under applicable law. Thus, if You would be entitled to a larger amount under the applicable law, this provision does not preclude the arbitrator from awarding You that amount. However, You may not recover duplicative awards of attorneys' fees or costs. Although under some laws We may have a right to an award of attorneys' fees and expenses if it prevails in an arbitration, We agree that We will not seek such an award.
- (6) The arbitrator may award declaratory or injunctive relief only in favor of the individual party seeking relief and only to the extent necessary to provide relief warranted by that party's individual claim. **YOU AND WE AGREE THAT EACH MAY BRING CLAIMS AGAINST THE OTHER ONLY IN YOUR/OUR INDIVIDUAL CAPACITY, AND NOT AS A PLAINTIFF OR CLASS MEMBER IN ANY PURPORTED CLASS OR REPRESENTATIVE PROCEEDING.** Further, unless both You and We agree otherwise, the arbitrator may not consolidate more than one person's claims, and may not otherwise preside over any form of a representative or class proceeding. If this provision is found to be unenforceable, then the entirety of this provision shall be null and void.
- (7) Notwithstanding any provision in this **Agreement** to the contrary, We agree that if We make any future change to this provision (other than a change to the Notice Address) during Your **Agreement**, You may reject any such change by sending us written notice within 30 days of the change to the Arbitration Notice Address provided above. By rejecting any such change, You are agreeing that You will arbitrate any dispute between us in accordance with the language of this provision.

## SPECIAL STATE REQUIREMENTS/DISCLOSURES

The following Special State Requirements and/or Disclosures apply if this Contract was purchased in one of the following states and supersede any other provision herein.

### CALIFORNIA

The **Agreement Administrator** and Obligor is AMT Warranty Corp. California License #0H18143.

**Our** obligations under this **Agreement** are insured by policy issued by Wesco Insurance Company, 59 Maiden Lane, 43rd Floor, New York, NY 10038, 800-927-4357. **You** may file a claim with this insurance company if any promise made in this Maintenance **Agreement** has been denied or has not been honored within sixty (60) days after the date the proof of loss was filed. If **You** are not satisfied with the insurance company's response, **You** may contact the California Department of Insurance at (800) 927-4357.

CANCELLATION OF **YOUR AGREEMENT** section is deleted and replaced with the following:

If **You** cancel this **Agreement** within sixty (60) days and no claims have been filed, the entire **Agreement** charge will be refunded. If **You** cancel this **Agreement** within sixty (60) days and have paid or approved claims, **We** will refund an amount of the **Agreement** price according to the pro-rata method reflecting the greater of the days in force or the miles driven based on the term/miles selected and the date the **Agreement** begins. If **You** cancel this **Agreement** after sixty (60) days, **We** will refund an amount of the **Agreement** price according to the pro-rata method reflecting the greater of the days in force or the miles driven based on the term/miles selected and the date the **Agreement** begins, an administrative fee not to exceed the lesser of twenty-five dollars (\$25.00) or 10% of the **Agreement** cost charged will be charged.

If **We** cancel this **Agreement** the cancellation refund will be paid within thirty (30) days of the cancellation and a notice of cancellation will be mailed to **You** listing the reason for cancellation. The **Agreement** ceases to be valid no less than five (5) days after the postmark date of such notice. If **We** cancel this **Agreement** within sixty (60) days, the entire **Agreement** price will be refunded, less any claims paid or approved for payment prior to the cancellation date. After sixty (60) days, **We** may only cancel this **Agreement** for non-payment, fraud, or material misrepresentation. If **We** cancel this **Agreement** after sixty (60) days, **We** will refund an amount of the **Agreement** price according to the pro-rata method reflecting the greater of the days in force or the miles driven based on the term/miles selected and the date **Agreement** begins. If **We** cancel this **Agreement**, no administrative fee will be charged. In the event of cancellation, any claim filed and/or approved prior to the cancellation date will be honored and/or reviewed for coverage under the terms of the **Agreement**.

Under the Arbitration Provision the following is added: This Provision shall inure to the benefit of and be binding on You and Us following exhaustion of Your right to file claims with the Insurance Company and/or the California Department of Insurance ("DOI") as specified on the **Registration Page**. However, if You choose to forego Your right to file Your claims with the Insurance Company and the DOI, You waive those rights and this Provision will be enforced and binding. The arbitrators shall not have the power to commit errors of law or legal reasoning, and the award may be vacated or corrected on appeal to a court of competent jurisdiction for any such error. Reference to the Federal Arbitration Act in the Arbitration Provision of this **Agreement** shall be replaced with the following citation: CAA (CCP § 1280 et seq). The reference to the class action waiver is hereby stricken from the ALL CAPS portion of the Arbitration Provision in this **Agreement**. The choice of law for all California residents is California. The fee provision in the Arbitration Provision of this **Agreement** shall be amended to include California Code of Civil Procedure, Title 9, Chapter 1 § 1284.3.









# CAC SR Data Share

**Save XLSM to Desktop**

**Save PDF to Desktop**

**Clear Form**

- After completing the SRDS, do this: (Revised 4/7/15!)**
- 1) Grey 'Spellcheck' button to check spelling (at the bottom)
  - 2) Blue 'Save XLSM to Desktop' button
  - 3) Green 'Save PDF to Desktop' button & CLOSE the PDF file (red x)
  - 4) Copy 'Key Points' (pink cell) to new "SR Summary" Comments
  - 5) Attach the Excel file (SRDS-Excel.xlsm) to the SR
  - 6) Attach the PDF file ('SRDS-PDF.pdf') to the A02 email for CEMs
  - 7) Red 'Clear Form' button
  - 8) Complete a new SRDS; Save over the PDF & Excel files all day

Customer's name (for your reference):

John Bauer

Key Points:

Customer states when my headlights are on low, they would go completely off and there was nothing you could do to get them back on. They would go off and in 3-4 minutes they would reset and come back on. Palm Auto Mall and they replaced the relay and that corrected the problem for 2 months. Then driving the other night it went off again and reset again exactly like it did before. I was told my one dealership that the headlight switch needs to be replaced. Customer seeks repairs. Advised customer we would waive 1hr of diagnostic fee to have vehicle looked at will notify the CE Manager Frank Sirse that you will be calling next week to setup an appointment

**What is the customer's concern?**

**What help is the customer seeking?**

**What expectations did you set for the customer?**

You are empowered to deliver **Exceptional Customer Experiences!**

Customer's preferred phone #:

[REDACTED]

Best time to call customer:

anytime

Has the customer had the current concern diagnosed by a GM Dealer?	A GM Dealer has diagnosed the current concern
What is the status of the repairs (to address the current concern)?	Repairs have not been scheduled
How many times has vehicle been serviced for this same concern (at any svc location)?	2
How many <u>days</u> has vehicle been inoperable (down) because of this concern?	1
Current status of the vehicle (operable or inoperable)?	Vehicle is currently operable & can be driven
Has customer spent money out-of-pocket as a result of this concern?	No
Current mileage (in <u>miles</u> )?	43,000
Bought brand new?	No
<i>(if bought used)</i> Roughly how many <u>miles</u> were on the vehicle at time of purchase?	
<i>(if bought used)</i> Was vehicle bought (used) at a GM Dealership?	
Did customer purchase an Extended Service Contract (GM, Divisional, Aftermarket)?	No

**End conversation with the customer here. Complete the rest of the SR Data Share in ACW (After Call Work).**

Today's date:	5/13/2015
SR#	
CAC advisor's name (first & last):	Willie Maddox
CAC advisor's phone #:	(866) 790-5600
CAC advisor's extension #:	31109
17-digit VIN#:	1GKDT43S792
Make:	GMC
Model:	envoy
Model Year:	2009
Is this a high-dollar or premium vehicle?	No
Does this VIN have any <u>active</u> Extended Service Contracts?	No
Does Order Type contain the word "FLEET"?	No
Branded Title?	No
Warranty Block?	No
Warranty Start Date for this VIN:	8/27/2009

*(if bought used)* Is this a GM Certified pre-owned used vehicle?

No

Is this the original owner?

No

List of GM vehicles owned by this customer:  
*(including the vehicle they're calling about now)*

1GKDT43S792 [REDACTED]

Total number of GM vehicles this customer has owned:  
*(including the vehicle they're calling about now)*

1

**Customer**

[Redacted]  
Call anytime

**Vehicle**

2009 GMC envoy  
1GKDT43S792 [Redacted]  
Mileage now: 43000 mi

**Status of vehicle/concern**

A GM Dealer has diagnosed the current concern  
Repairs have not been scheduled  
Vehicle is currently operable & can be driven

**Key Points**

Customer states when my headlights are on low, they would go completely off and there was nothing you could do to get them back on. They would go off and in 3-4 minutes they would reset and come back on. Palm Auto Mall and they replaced the relay and that corrected the problem for 2 months. Then driving the other night it went off again and reset again exactly like it did before. I was told my one dealership that the headlight switch needs to be replaced. Customer seeks repairs. Advised customer we would waive 1hr of diagnostic fee to have vehicle looked at will notify the CE Manager Frank Sirse that you will be calling next week to setup an appointment

Supporting Factors	Limiting Factors
<p>First time GM buyer (verified)</p> <p>Vehicle has been serviced for this concern: 2 time(s) Vehicle was inop/down due to this concern: 1 day(s)</p>	
<p><u>Please consider these additional questions:</u>                      Close to any applicable expiration limit? (wrnty, spl covg, svc contrt)                      Did cust buy an extd svc contract, but it's expired or n/a?                      Is this a loyal service customer? (to involved dealer)                      Are high dollar customer-pay ROs on record for this cust?                      Is this a conquest buyer?</p>	<p><u>Please consider these additional questions:</u>                      Is vehicle way beyond all applicable expiration limits?                      Does veh have an active <u>aftermarket</u> Extd Svc Contract?                      Did customer buy vehicle outside of warranty?                      Does it seem customer doesn't take care of the vehicle?                      Is cause not normally covered by warranty?                      Is cause due to an accident insurance won't cover?                      Is cause due to damage by independent repair facility?</p>

**Additional key points**

This customer has purchased these GM vehicles (verified): 1GKDT43S792 [Redacted]

**Reference**

CAC SR#: [Redacted] 7  
 CAC advisor: Willie Maddox--> (866) 790-5600 , Ext # 31109

## **General Excel Tips:**

Right click on any cell with a comment & choose "Show/Hide Comments" to make the Comment stick (stay visible)  
When you're done, Right click the cell with the comment showing & choose "Show/Hide Comments" to make the

Ctrl+C to copy; Ctrl+V to paste; Ctrl+X to cut

If you leave & come back, click inside the cell & pick up at the blinking cursor (to prevent typing on top of what was

Alt+Enter lets you return to the next line inside a cell

Alt + down arrow key will show you the dropdown menu/choices list (do this if you don't like using a mouse)

even when you click away from that cell).  
Comment go away (become hidden from immediate view).

is already there)



Hummer

Yes - This V

Unresolved - Customer No - This is

Diagnosed

No

IN has received goodwill or cost assistance

a new SR



December 13, 2017

[REDACTED]  
New Albany, IN [REDACTED]

[REDACTED],  
At Buick, we take pride in the vehicles we produce and appreciate the time you took to contact us.

Because customer satisfaction is a top priority for us, please accept this letter worth up to \$100 towards your next maintenance service or repair on your 2006 Buick Rainier CXL.

This offer is valid towards one service visit on VIN 5GAES13M8621 [REDACTED]. In the event the cost of your service exceeds the \$100 maximum value, you will be responsible for paying the difference. If the total cost of your services is less than \$100, a credit or refund will not be issued. This letter is not transferable and is valid for 12 months from the date of issue.

We hope this gesture demonstrates our appreciation of you as a valued customer. Simply present this letter to any Buick dealership for redemption. If you have future questions, please don't hesitate to email us using the Contact Us link at Buick.com or call us at 1-800-521-7300.

Sincerely,

Buick Customer Assistance Center  
Service Request [REDACTED]

For more information regarding the maintenance and care of your vehicle, please visit [www.gm.com/vehicles/owner\\_advantages.html](http://www.gm.com/vehicles/owner_advantages.html). This free online service offers vehicle and ownership-related information and tools tailored to your specific vehicle.

---

ATTENTION: DEALERSHIP SERVICE MANAGER

When submitting the claim, please use labor op 0600046. Insert the amount in the net item column and insert the CAC Service Request number in your comments. This original letter must be surrendered by the customer and retained by the dealer for audit purposes.



**Kelley Blue Book** The Trusted Resource<sup>®</sup>



Advertisement

Why ads?

# 2004 Chevrolet TrailBlazer Pricing Report



**Style:** LS Extended Sport Utility 4D  
**Mileage:** 206,000

Trade In to a Dealer



Trade-in Values valid for your area through 5/21/2015  
 Good Condition

## Vehicle Highlights

**Fuel Economy:**  
 City 14/Hwy 19/Comb 16 MPG

**Max Seating:** 7

**Doors:** 4

**Engine:** 6-Cyl, 4.2 Liter

**Drivetrain:** 4WD

**Transmission:** Automatic

**EPA Class:** Sport Utility Vehicles

**Body Style:** Extended Sport Utility

**Country of Origin:** United States

**Country of Assembly:** United States

## Your Configured Options

Our pre-selected options, based on typical equipment for this car.

✓ Options that you added while configuring this car.

### Engine

6-Cyl, 4.2 Liter

### Transmission

Automatic

### Drivetrain

4WD

### Braking and Traction

ABS (4-Wheel)

### Comfort and Convenience

Air Conditioning  
 Power Windows  
 Power Door Locks

### Steering

Power Steering  
 Tilt Wheel

### Entertainment and Instrumentation

AM/FM Stereo  
 CD (Single Disc)

### Safety and Security

Dual Air Bags

### Roof and Glass

Privacy Glass

### Cargo and Towing

✓ Roof Rack  
 Towing Pkg

### Wheels and Tires

Alloy Wheels

## Glossary of Terms

**Kelley Blue Book<sup>®</sup> Trade-in Value** - This is the amount you can expect to receive when you trade in your car to a dealer. This value is determined based on the style, condition, mileage and options indicated.

**Trade-In Range** - The Trade-In Range is Kelley Blue Book's estimate of what you can reasonably expect to receive this week based on the style, condition, mileage and options of your vehicle when you trade it in to a dealer. However, every dealer is different and values are not guaranteed.

**Kelley Blue Book<sup>®</sup> Private Party Value** - This is the starting point for negotiation of a used-car sale

### Tip:

It's crucial to know your car's true condition when you sell it, so that you can price it appropriately. Consider having your mechanic give you an objective report.

between a private buyer and seller. This is an "as is" value that does not include any warranties. The final price depends on the car's actual condition and local market factors.

**Private Party Range** - The Private Party Range is Kelley Blue Book's estimate of what you can reasonably expect to receive this week for a vehicle with stated mileage in the selected condition and configured with your selected options, excluding taxes, title and fees when selling to a private party.

**Excellent Condition** - 3% of all cars we value. This car looks new and is in excellent mechanical condition. It has never had paint or bodywork and has an interior and body free of wear and visible defects. The car is rust-free and does not need reconditioning. Its clean engine compartment is free of fluid leaks. It also has a clean title history, has complete and verifiable service records and will pass safety and smog inspection.

**Very Good Condition** - 23% of all cars we value. This car has minor wear or visible defects on the body and interior but is in excellent mechanical condition, requiring only minimal reconditioning. It has little to no paint and bodywork and is free of rust. Its clean engine compartment is free of fluid leaks. The tires match and have 75% or more of tread. It also has a clean title history, with most service records available, and will pass safety and smog inspection.

**Good Condition** - 54% of all cars we value. This car is free of major mechanical problems but may need some reconditioning. Its paint and bodywork may require minor touch-ups, with repairable cosmetic defects, and its engine compartment may have minor leaks. There are minor body scratches or dings and minor interior blemishes, but no rust. The tires match and have 50% or more of tread. It also has a clean title history, with some service records available, and will pass safety and smog inspection.

**Fair Condition** - 18% of all cars we value. This car has some mechanical or cosmetic defects and needs servicing, but is still in safe running condition and has a clean title history. The paint, body and/or interior may need professional servicing. The tires may need replacing and there may be some repairable rust damage.

---

© 1995-2015 Kelley Blue Book Co.®, Inc. All rights reserved.

© 2015 Kelley Blue Book Co., Inc. All rights reserved. 5/15/2015-5/21/2015 Edition for North Carolina 28080. The specific information required to determine the value for this particular vehicle was supplied by the person generating this report. Vehicle valuations are opinions and may vary from vehicle to vehicle. Actual valuations will vary based upon market conditions, specifications, vehicle condition or other particular circumstances pertinent to this particular vehicle or the transaction or the parties to the transaction. This report is intended for the individual use of the person generating this report only and shall not be sold or transmitted to another party. Kelley Blue Book assumes no responsibility for errors or omissions. (v.15052)

### Fire Case template

Type of case	Melt Case	
Status	New	
SR Number	[REDACTED]	
Customer Name (Last name/First Name)	[REDACTED]	
Year/Make/Model	2004 Chevrolet TrailBlazer	
VIN	1GNET16P24612 [REDACTED]	
Incident Date	5/16/2015	
Purchase Date	about 3 months ago	
Titled in who's name	[REDACTED]	
Purchase Price	[REDACTED]	
Open/Closed Recalls (If closed include closed Transaction History)	<p>[REDACTED] Transaction History)  <i>"Product Safety Recall N050044 05044 INTERMITTENT INCORRECT TURN SIGNAL OPERATION 07/28/2005 Closed 10/14/2005 653109 ZREG---Regular Vehicle Transaction L1281 - Fuel Tank Replacement - Left Side 22,202 MI  08/19/2005 647297 ZFAT---Field Action Recall V1388 - 05044 - Replace Flasher Relay 19,385 MI  04/11/2005 632198 ZREG---Regular Vehicle Transaction B8990 - Rear License Plate Pocket Replacement 12,384 MI</i></p>	
Mileage	206,000	
Purchased From	third party car lot	
Vehicle Insured	Yes	
MSRP/KBB (Trade-in Good Value)	\$2,512.00	
Loaner Vehicle (yes/no from drop down and enter date issued)	No	n/a
Additional Information as requested by TC/TL		

Verify before sending E-mail:

**IS THE FORM COMPLETE WITH ALL INFORMATION?**

**Have Photos been attached in Seibel**

please review to ensure photos are clear and show damage

Must include at least one close up showing damage/fire, Overall of damaged area, Broad view to show the envi

**One Call Handling: Please include in body of email why case is being closed on the first "new email".**

If necessary include copy of any additional fire/police reports, dealer inspections, and copy of title and registration.

If you are handling a case that requires ESISQFYI activity please confirm that this activity has been completed in the system.

All fire cases with ESISQFYI requires email notification to the TC and TCL regardless if case remains open or closed.

Case Summary

customer alleged her vehicle caught on fire in the fuse box; she and her husband were driving down the street when they smelled smoke and plastic burning; they pulled into an Autozone lot and opened the hood; there was a lot of smoke; once the smoke cleared they opened the fuse box and saw the relay switch and wiring had melted; the vehicle is currently located at Abernethy Chevrolet; photos are attached to SR

To: Mickey.sabol@gm.com

Cc: Kimberly.horvath@gm.com

Subject: New - Melt Case SR# [REDACTED]

PASTE TEMPLATI

ronment surrounding the area and a photo of all four sides of vehicle exterior.

on as necessary.

n Siebel prior to sending the Fire Case Initial Email to the Fire Team.  
ed on first contact.

E IN EMAIL USING CTRL+V



Fire Case  
Smoke Case  
Melt Case

New  
Reopen  
Photos  
Update  
Inspection received  
Question

Closed

*Estimate is*

Yes

No













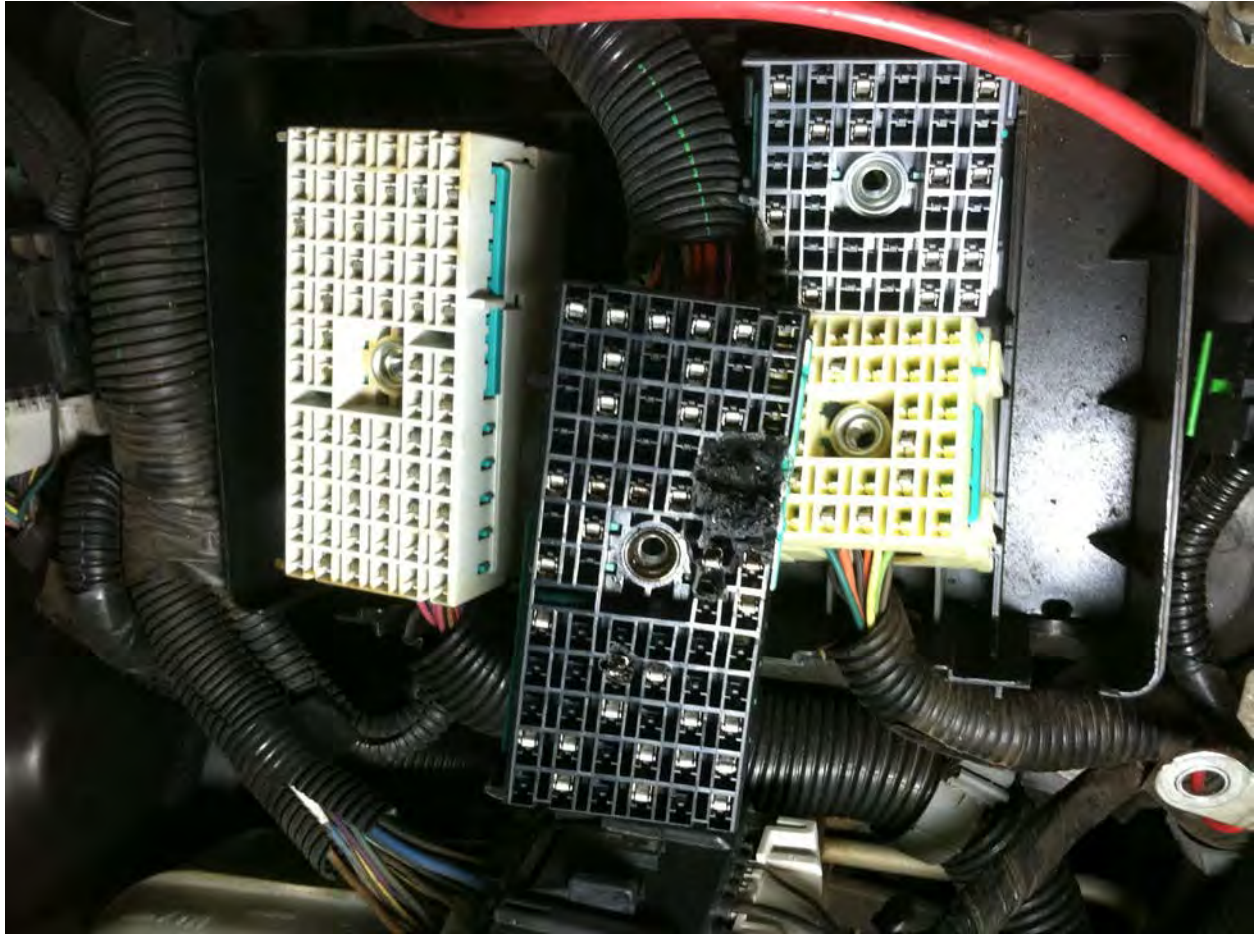





Product Assistance Center  
Preliminary Technical Consultant Report

Date: 5/21/2015

VIN: 1GNET16P246 [REDACTED]

SR #: [REDACTED]

Customer Name: [REDACTED]

Case Matter [REDACTED]

PAC Advisor: Shonda Love

Report/Recommendation:

Based upon available information, the customer's statements, and photos, it appears that the origin of the fire is consistent with field action 14291. 14291 is not associated with this vehicle. The customer stated the incident occurred on 5/16/2015 and the vehicle mileage is stated as 206,000.

Based on the available information, it is recommended that the vehicle be repurchased or repaired as appropriate.

If any additional information becomes available, this report may be revised.

Mickey Sabol  
PAC Technical Consultant















# V8



### MINIFUSES

- 1 - ECAS (30A)
- 2 - HI HOLD-UP-RT (10A)
- 3 - LOW HOLD-UP (10A)
- 4 - TRLR BAU (10A)
- 5 - HI HOLD-UP-LT (10A)
- 6 - LOW HOLD-UP-LT (10A)
- 7 - WASH (20A)
- 8 - REC (30A)
- 9 - W/S WASH (15A)
- 10 - PCM B (20A)
- 11 - FOG LP (15A)
- 12 - STLP (25A)
- 13 - O/GAR (25A)
- 14 - COILS (10A)
- 15 - CANISTER VENT (10A)
- 16 - TBC IGN1 (10A)
- 17 - CRANK (15A)
- 18 - BR (10A)

- 20 - FAN (10A)
- 21 - HORN (15A)
- 22 - IGN E (10A)
- 23 - TAC (15A)
- 24 - IPC/ONC (10A)
- 25 - BTG (10A)
- 26 - EMS 1 (10A)
- 27 - BACK-UP (15A)
- 28 - PCM 1 (10A)
- 30 - A/C (10A)
- 31 - TBC 1 (10A)
- 50 - TR L TRN (10A)
- 51 - TR L TRN (10A)
- 52 - PLASH (25A)
- 53 - O2 A (15A)
- 54 - O2 B (15A)
- 55 - INJ A (15A)
- 56 - INJ B (15A)
- 57 - EAP (15A)

### J-CASE FUSES

- 32 - TRALER (50A)
- 33 - ABS (50A)
- 34 - IGN A (40A)
- 35 - BLOWER (40A)
- 36 - IGN B (40A)

### MICRO RELAYS

- 37 - HELP WASH
- 38 - REAR WASH
- 39 - FOG LP
- 40 - HORN
- 41 - F/SMP
- 42 - W/S WASH
- 43 - HOLPH9
- 44 - A/C
- 45 - EAP

### SOLID STATE RELAYS

- 45 - FAN
- 46 - HOM

### MINI RELAYS

- 47 - STARTER
- 58 - IGN 1

### MISCELLANEOUS

- 48 - 12V BATT (125A)

PRINTED IN USA



15-42332B











Close Window

# Edit Transaction Pre-Repair Authorization

PRINT-FRIENDLY VERSION

This screen allows the user to edit existing Pre-Repair Authorization.

Business Unit\*: GM - US

Transaction Type\*: ZREG—Regular Vehicle Transaction

Pre-Repair Type: Repair Authorization

## Pre-Repair Authorization

Pre-Repair Auth ID:

Original Author: Erica Jesse

New Author: Erica Jesse

\*Required Fields  
Disclaimer: All amounts are before taxes

BAC\*: 113950

Service Agent: ABERNETHY CHEVROLET BUICK GMC

Contact Name: Greg Stroup

Phone Number: 7047350401

Fax Number:

Contact Email Address: cgstroup@abernethychevrolet.com

Job Card\*: 409875

Job Card Date: 05/28/2015

Reference Number:

VIN: 1GNET16P24 [Investigate Vehicle History](#)

Odometer: 173000

- Transaction Flag:
- Customer Enthusiasm - Non Warrantable Repair
  - Special Coverage
  - Policy
  - None

Customer Complaint Category\*: 09—No Customer Complaint

Complaint Code\*: 0090—No Customer Complaint - Other issues

Description\*: No customer complaint-Other issues

Cause Code\*:

9090 , Other - Field Action / Tech Bulletin

Description: \* Other-Field Action/Tech Bulletin

Correction Description: \* Repair Vehicle

Labour Operation\*: 0600006

Labour Time: 7.5 Supp Time: 0 OLH Time: 0

Labour Rate: 90.69 Common GM Division - Mechanical

Labour Total: 680.18

Parts Total: 987.67

Part Numbers:

Net Item Type

Amount

Car Rental / Hire 164

<Make Selection>

Net Item Total: 164.00

Tax: 0

Deductible: 0

Total Before Taxes: 1,831.85

Auth Code:

Accept Reject

Comment:

Created By Erica Jesse Create Date/Time Fri May 29 09:11:09 EDT 2015 Comment Please include Pre Auth ID when you submit your claim.

Reassign Comments: Created By Comment From Assigned To

Attachments:

No rows were found.

Attachment Id	Attachment Name	User Name
---------------	-----------------	-----------

Browse...

ADD

DELETE

Pre Repair Authorization History:

VIN	Pre-Repair Authorization ID	Create Date
1GNET16P246 [REDACTED]	[REDACTED]	2015-05-29

CANCEL

SAVE

# CAC SR Data Share

**Save XLSM to Desktop**

**Save PDF to Desktop**

**Clear Form**

- After completing the SRDS, do this: (Revised 4/7/15!)**
- 1) Grey 'Spellcheck' button to check spelling (at the bottom)
  - 2) Blue 'Save XLSM to Desktop' button
  - 3) Green 'Save PDF to Desktop' button & CLOSE the PDF file (red x)
  - 4) Copy 'Key Points' (pink cell) to new "SR Summary" Comments
  - 5) Attach the Excel file (SRDS-Excel.xlsm) to the SR
  - 6) Attach the PDF file ('SRDS-PDF.pdf') to the A02 email for CEMs
  - 7) Red 'Clear Form' button
  - 8) Complete a new SRDS; Save over the PDF & Excel files all day

Customer's name (for your reference): Eilene Russell

Key Points: Customer states that last year, the headlamps only worked in the high beam setting; they replaced the relay with an O'Reilly Auto Store part) & problem was corrected. Now the headlamp is out & they found that the relay is melted. Customer feels that this issue should be covered under Recall 14291-dealership has stated there is no recall on the vehicle.

**What is the customer's concern?**  
**What help is the customer seeking?**  
**What expectations did you set for the customer?**

Customer seeking repair coverage; states this is the exact same issue as stated in the recall & should be covered.

You are empowered to deliver **Exceptional Customer Experiences!**

SA advised the dealership will be requested to double check the VIN & contact her to discuss the recall & needed repair. SA advised that there no permanent repair at this time, but a temporary repair (replacement on the current model HDM).

Customer's preferred phone #: [REDACTED]

Best time to call customer: any time

Has the customer had the current concern diagnosed by a GM Dealer?	A GM Dealer has NOT diagnosed current concern
What is the status of the repairs (to address the current concern)?	Repairs have not been scheduled
How many times has vehicle been serviced for this same concern (at any svc location)?	0
How many <u>days</u> has vehicle been inoperable (down) because of this concern?	0
Current status of the vehicle (operable or inoperable)?	Vehicle is currently operable & can be driven
Has customer spent money out-of-pocket as a result of this concern?	Yes
Current mileage (in <u>miles</u> )?	107,000
Bought brand new?	No
<i>(if bought used)</i> Roughly how many <u>miles</u> were on the vehicle at time of purchase?	4,000
<i>(if bought used)</i> Was vehicle bought (used) at a GM Dealership?	Yes
Did customer purchase an Extended Service Contract (GM, Divisional, Aftermarket)?	No

**End conversation with the customer here.** Complete the rest of the SR Data Share in ACW (After Call Work).

Today's date:	6/1/2015
SR#	[REDACTED]
CAC advisor's name (first & last):	Margaret Quigley
CAC advisor's phone #:	(866) 790-5600
CAC advisor's extension #:	11710
17-digit VIN#:	1GNDS13S97 [REDACTED]
Make:	Chevrolet
Model:	TrailBlazer
Model Year:	2007
Is this a high-dollar or premium vehicle?	No
Does this VIN have any <u>active</u> Extended Service Contracts?	No
Does Order Type contain the word "FLEET"?	Yes
Branded Title?	No
Warranty Block?	No
Warranty Start Date for this VIN:	11/7/2006

*(if bought used)* Is this a GM Certified pre-owned used vehicle?

Yes

Is this the original owner?

No

List of GM vehicles owned by this customer:  
*(including the vehicle they're calling about now)*

2007 Chevrolet TrailBlazer

Total number of GM vehicles this customer has owned:  
*(including the vehicle they're calling about now)*

1

**Customer**

[Redacted]  
[Redacted]  
Call any time

**Vehicle**

2007 Chevrolet TrailBlazer  
1GNDS13S97 [Redacted]  
Mileage now: 107000 mi

**Status of vehicle/concern**

A GM Dealer has NOT diagnosed current concern  
Repairs have not been scheduled  
Vehicle is currently operable & can be driven

**Key Points**

Customer states that last year, the headlamps only worked in the high beam setting; they replaced the relay with an O'Reilly Auto Store part) & problem was corrected. Now the headlamp is out & they found that the relay is melted. Customer feels that this issue should be covered under Recall 14291-dealership has stated there is no recall on the vehicle.

Customer seeking repair coverage; states this is the exact same issue as stated in the recall & should be covered.

SA advised the dealership will be requested to double check the VIN & contact her to discuss the recall & needed repair. SA advised that there no permanent repair at this time, but a temporary repair (replacement on the current model HDM).

Supporting Factors	Limiting Factors
GM Certified Pre-Owned vehicle (verified) First time GM buyer (verified)  Customer has incurred costs due to this concern	Vehicle is > 8 years old (verified) Vehicle has > 100,000 miles Current or former fleet vehicle (verified)
<p><u>Please consider these additional questions:</u>                      Close to any applicable expiration limit? (wrnty, spl covg, svc contrt)                      Did cust buy an extd svc contract, but it's expired or n/a?                      Is this a loyal service customer? (to involved dealer)                      Are high dollar customer-pay ROs on record for this cust?                      Is this a conquest buyer?</p>	<p><u>Please consider these additional questions:</u>                      Is vehicle way beyond all applicable expiration limits?                      Does veh have an active <u>aftermarket</u> Extd Svc Contract?                      Did customer buy vehicle outside of warranty?                      Does it seem customer doesn't take care of the vehicle?                      Is cause not normally covered by warranty?                      Is cause due to an accident insurance won't cover?                      Is cause due to damage by independent repair facility?</p>

**Additional key points**

Per the customer, this vehicle was bought (used) at a GM Dealership  
 Approximate # of miles on the vehicle when customer purchased it (used): 4000 mi  
 This customer has purchased these GM vehicles (verified): 2007 Chevrolet TrailBlazer

**Reference**

CAC SR#: [Redacted]  
 CAC advisor: Margaret Quigley--> (866) 790-5600 , Ext # 11710

## **General Excel Tips:**

Right click on any cell with a comment & choose "Show/Hide Comments" to make the Comment stick (stay visible)  
When you're done, Right click the cell with the comment showing & choose "Show/Hide Comments" to make the

Ctrl+C to copy; Ctrl+V to paste; Ctrl+X to cut

If you leave & come back, click inside the cell & pick up at the blinking cursor (to prevent typing on top of what was

Alt+Enter lets you return to the next line inside a cell

Alt + down arrow key will show you the dropdown menu/choices list (do this if you don't like using a mouse)

even when you click away from that cell).  
Comment go away (become hidden from immediate view).

is already there)



Hummer

Yes - This V

Unresolved - Customer No - This is

Diagnosed

No

IN has received goodwill or cost assistance

a new SR



Connecting.....A live chat agent is now entering the chat.

Caller English

System [10:20:47 AM]:

Welcome to chat.

Shakevia [10:20:58 AM]:

Hi! Thank you for visiting us today. How may I help you?

[REDACTED] [10:23:16 AM]:

My 2007 Trailblazer is having a problem with low beam and daytime running lights. This problem is subject to a recall, but my dealer says they know nothing about the recall.

Shakevia [10:24:20 AM]:

I am sorry that you are having this issue with the vehicle. I am happy to look into your vehicle information for any possible recalls. Can you please provide your VIN and current mileage?

[REDACTED] [10:26:23 AM]:

GM has said that over 300,000 Suvs and sadans are to be recalled. When will the dealers be notified.

Shakevia [10:27:24 AM]:

I am happy to look into this for you. Although being as though recalls are VIN specific I would need your VIN to confirm that your vehicle has any recalls.

[REDACTED] [10:29:38 AM]:

My vehicle is already up for one recall but I never got a recall letter from GM. Vin #1gnds13s172 [REDACTED]

Shakevia [10:30:56 AM]:

Thank you for this information/.

Shakevia [10:33:17 AM]:

There is only one recall for your vehicle. That is the Driver Door Switch. I am unsure of why you would not have gotten the recall notice. Are you the original owner of the vehicle?

[REDACTED] [10:35:51 AM]:

Yes. And yes there is to be a recall on the Headlight module. So why can,t you tell me when that will be. Driving at night and your headlights stop working is a very dangerous situation. This needs to be fixed.

Shakevia [10:40:48 AM]:

If the recall has not been released we would not have any information of it. Recall information is only available once the recall has been released and is attached to the vehicles VIN that are included in the recall. I would advise taking your vehicle in to a GM Dealer to get your vehicle diagnosed and repaired. If a recall is released for this concern and your vehicle is included in the recall you will be able to submit for reimbursement to the cost that you paid for the repair.

Shakevia [10:42:25 AM]:

Can you please provide me with the source where you found this information. I am happy to document this information in our system.

[REDACTED] [10:46:06 AM]:

Thanks. But you have not provided any more information than I was able to find out for myself. This information is the subject of the 79th recall issued by GM. It can be found on several sites. Major networks and publications. You have to look very hard to find it. Just google Gm 79th recall.

Shakevia [10:48:13 AM]:

I am happy to document this information, Although I can not confirm that this information is correct as these are not certified GM websites. I would recommend visiting [media.gm.com](http://media.gm.com) for recall information.

Shakevia [10:50:04 AM]:

Is there anything else that I may assist you with at this time?

[REDACTED] [10:50:14 AM]:

Why would this not be correct if GM sent the memo? GM needs to step up and fix the problem. It might save someone's life.

[REDACTED] [10:51:22 AM]:

GM informed the National Safety Administration.

Shakevia [10:51:41 AM]:

GM is not affiliated with all sites and does not provide this information to them. I have provided you with the correct site to locate recall information that is Authorized by GM.

Shakevia [10:52:19 AM]:

Thank you this information. I will be sure to document your concerns.

[REDACTED] [10:52:47 AM]:

Have a nice day. You and GM were of no help.

Shakevia [10:52:54 AM]:

You're welcome. I'm glad I could help you today during your visit. Please don't hesitate to come back and chat with us. We are here to chat Monday through Friday from 8:00 a.m. to 11:00 p.m., Saturday from 9:00 a.m. to 11:00 p.m. and Sunday from 12:00 p.m. to 9:00 p.m. Eastern time.

You have been disconnected from the chat session. If you require further assistance, please start another chat session or visit [it.support.gm.com](https://it.support.gm.com) for more support options.



ZIP CODE: 43224 | Sign in (or Sign up)

- Home
- Car Values
- Cars for Sale
- Car Reviews
- Awards & Top 10s
- Research Tools

Popular at KBB.com

[Compact SUV Buyer's Guide](#)

Advertisement

Why ads?

Home > Car Values > Chevrolet > TrailBlazer > 2003 > Style > Options > LTZ Sport Utility 4D

Chevrolet TrailBlazer 2003 Go

# Your Blue Book® Value

[Show Used Car Prices](#) | [Price Your Next Car](#)



## 2003 Chevrolet TrailBlazer

Style: LTZ Sport Utility 4D

[Edit options](#) | [Check specs](#)

Mileage: 170000 [Change](#)

Like 6

Trade In to a Dealer

Get an Instant Cash Offer

Sell to a Private Party

[Print report](#)



Good Condition

Trade-in Values valid for your area through 6/11/2015  
[Track this car's values](#)

### Price a New Car

Then browse reviews, photos, specs and more.

[See what you should pay](#)

### Instant Cash Offer

Find local dealers ready to buy your car - today!

[Get your offer](#)

backed by

Advertisement

Why ads?

### Tell Us About This Car

Owners like you rated the 2003 TrailBlazer 8.2 out of 10.

[Write your own review](#)

Advertisement

Why ads?

## Next Steps to Selling Your Car

### Benchmark Local Prices

See what dealers and private sellers in your area are asking for your car.

[See listings](#)

### Give Buyers Confidence

Show them a clean AutoCheck vehicle

Enter VIN (optional)

[Go](#)

history report and close the deal fast.

List It for Sale

ON ROAD TO THE FUTURE

SHOPPING  TOYOTA?

SEARCH THE

Recently Viewed Cars

My Saved Cars

Save car

g+



OF INVENTORY



CLICK HERE

### Free Dealer Price Quote

Get the best price and be more prepared with your free, no-obligation price quote

Chevrolet

Model

ZIP Code 43224

Get your quote

Advertisement

Why ads?

SHOPPING  TOYOTA?

SEARCH THE  
LARGEST SELECTION  
OF INVENTORY



CLICK HERE

Advertisement

Why ads?

Search: Find car values or features

#### Popular Topics

- New Cars for 2015
- Used Cars
- Cars For Sale
- Best Resale Value Awards
- Brand Image Awards

#### Car Reviews & News

- Car Reviews
- Car Videos
- Auto Shows
- Car News
- Best Cars

#### Help

- FAQ
- Site Map
- Find a New Car
- What's My Car Worth
- KBB<sup>SM</sup> Mobile

#### Company

- About Us
- Contact Us
- Careers
- Corporate Information

#### Industry Relations

- Advertising
- Media Center
- Linking Policy
- Business Solutions

Follow KBB

Facebook

Twitter

Google+

YouTube

LinkedIn

RSS

Mobile Apps

iPhone

Android

© 1995-2015 Kelley Blue Book Co., Inc. All rights reserved. Copyright & Trademarks | Terms of Service | Privacy Policy | Ad Choices

Have comments about our Blue Book Values? Give us your feedback.

© 2015 Kelley Blue Book Co., Inc. All rights reserved. 6/5/2015-6/11/2015 Edition for Ohio 43224. The specific information required to determine the value for this particular vehicle was supplied by the person generating this report. Vehicle valuations are opinions and may vary from vehicle to vehicle. Actual valuations will vary based upon market conditions, specifications, vehicle condition or other particular circumstances pertinent to this particular vehicle or the transaction or the parties to the transaction. This report is intended for the individual use of the person generating this report only and shall not be sold or transmitted to another party. Kelley Blue Book assumes no responsibility for errors or omissions. (v.15061)











STATE OF OHIO - BUREAU OF MOTOR VEHICLE  
CERTIFICATE OF REGISTRATION

PLATE NO.: [REDACTED] REG. DATE: 12/08/2014 EXP. DATE: 12/08/2015 ISSUE DATE: 12/08/2014  
VALIDATION NO.: [REDACTED]  
OWNER NAME: [REDACTED] VEHICLE OWNERSHIP: SING

VEHICLE YEAR: 2003 VEHICLE CLASS: [REDACTED]  
BODY TYPE: SW ODOMETER READING: 165,990  
MAKE: CHEV

CERTIFICATE TITLE NO.: [REDACTED] PLATE TYPE: SUNBURST  
VEH. SERIAL NO.: 1GNND143399 [REDACTED] REG. TYPE: RENEWAL  
PURCHASE DATE: 09/18/2014

SUSPENSION/REVOCATION: NO  
PRIOR OPERATION: YES  
FEES PAID: YES

In Ohio, it is illegal to drive any motor vehicle without insurance or other financial responsibility (FR) coverage. It is also illegal for any motor vehicle owner to allow anyone else to drive the owner's vehicle without insurance. PROOF OF INSURANCE OR FR COVERAGE IS REQUIRED: Whenever a police officer issues a traffic ticket or citation, the driver must appear in court. Upon random checks by the Registrar of Motor Vehicles.

ANY DRIVER OR OWNER WHO FAILS TO SHOW PROOF OF INSURANCE OR OTHER COVERAGE WILL BE PENALIZED AS FOLLOWS: First offense, one year on second offense, and two years on third and subsequent offenses\* Lose his or her license, license plates, or registration AND\*Be required to maintain special FR coverage ("High-risk") for THREE or FIVE YEARS.

IF THIS SUSPENSION IS IN EFFECT: Any driver or owner who violates the suspension will have his or her license suspended for at least 30 DAYS first offense and 60 DAYS second offense. For third or subsequent offense, the driver will not be permitted to register any motor vehicle in Ohio for FIVE YEARS.

IF YOU ARE INVOLVED IN AN ACCIDENT WITHOUT INSURANCE OR OTHER FR COVERAGE, YOU WILL BE SUBJECT TO A SECURITY SUSPENSION for TWO YEARS or more and\*A JUDGEMENT SUSPENSION INDEFINITE. THESE PENALTIES ARE IN ADDITION TO ANY FINES OR PENALTIES IMPOSED BY A COURT. THERE IS ALWAYS THE POSSIBILITY THAT YOU MAY BE INVOLVED IN AN ACCIDENT WITH A PERSON WHO IS NOT INSURED. PROOF OF COVERAGE MAY BE SHOWN BY ANY OF THE FOLLOWING:\*



[Redacted]

[Redacted]

[Redacted]

[Redacted]

[Redacted]

12-08-2018

[Redacted]

SEX: F

BLU BRO



# OHIO CERTIFICATE OF TITLE

ISSUING CITY FRANKLIN  
RESIDENT CITY FRANKLIN

STATE OF OHIO No. 2  
ORIGINAL

IDENTIFICATION NUMBER  
1GNDT13S932 [REDACTED]

COMMENT 3

PURCHASE PRICE  
\$3,650.00

YEAR	MAKE	MAKE DESC
2003	CHEV	CHEVR
BODY TYPE	MODEL	MODEL DESC
SW	TRL	TRAILB

CONVERSION

TAX \$266.25  
REG BRAND ACTUAL

BRAND(S)  
OWNER

[REDACTED]  
COLUMBUS, OH [REDACTED]

PREVIOUS OWNER  
BILL LEGGETT AUTOMOTIVE INC  
4756 N HIGH ST  
COLUMBUS, OH 43214-0000

ECF  
Expires on \_\_\_\_\_  
Transfer \_\_\_\_\_  
Truck wt \_\_\_\_\_

2528

LIEN DISCHARGE

by \_\_\_\_\_

by \_\_\_\_\_  
Authorized Signature  
CLERK LIEN CANCELLATION

by \_\_\_\_\_  
Deputy Clerk

LIEN DISCHARGE

by \_\_\_\_\_

by \_\_\_\_\_  
Authorized Signature  
CLERK LIEN CANCELLATION

by \_\_\_\_\_  
Deputy Clerk

WITNESS MY HAND AND OFFICIAL SEAL THIS 10th DAY OF \_\_\_\_\_ (SEAL)  
%121372070

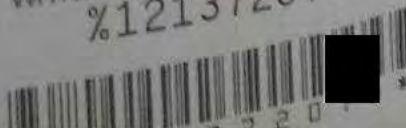

*Maryellen O'Shaughnessy*

MARYELLEN O'SHAUGHNESSY  
CLERK OF COURTS

QUALITY PEOPLE  
BUILD  
QUALITY PRODUCTS

MORaine  
OHIO



IUE-CWA  
A Union of World Trucks

Local  
798



**GM** MFD BY GENERAL MOTORS CORP 06/03  
GVWR 2608KG(5750LB) GAWR FRT 1338KG(2950LB) GAWR RR 1452KG(3200LB)  
THIS VEHICLE CONFORMS TO ALL APPLICABLE U.S. FEDERAL MOTOR  
VEHICLE SAFETY AND THEFT PREVENTION STANDARDS IN EFFECT ON  
THE DATE OF MANUFACTURE SHOWN ABOVE.  
1GNDT13S [REDACTED] TYPE: M.P.V.  
MODEL: T15506 PAYLOAD = 463KG(1021LB)  
TPMB TIRE SIZE SPEED RTG RIM COLD TIRE PRESSURE  
FRT P245/65R17 S 17X7J 220KPA(32PSI)  
RR P245/65R17 S 17X7J 220KPA(32PSI)  
SPA P245/65R17 S 17X7J 240KPA(35PSI)  
SEE OWNER'S MANUAL FOR MORE INFORMATION.

Product Assistance Center  
Preliminary Technical Consultant Report

Date: 6/16/2015

VIN: 1GNDDT13S93241 [REDACTED]

SR #: [REDACTED]

Customer Name: [REDACTED]

Case Matter [REDACTED]

PAC Advisor: Nancy Novak

Report/Recommendation:

Based upon available information, the customer's photos, it appears that the origin of the fire is consistent with field action 14291. The customer states they did not have any headlamp issues prior to the incident. 14291 is not associated with this vehicle. The customer stated the incident occurred on 6/6/2015 and the vehicle mileage is stated as 170,000.

Based on the available information, it is recommended that the vehicle be repurchased or repaired as appropriate.

If any additional information becomes available, this report may be revised.

Mickey Sabol  
PAC Technical Consultant

Nancy Novak (C)

---

From: Todd Bitzel <tbitzel@byersauto.com>  
Sent: Friday, June 19, 2015 8:24 AM  
To: Nancy Novak (C)  
Subject: RE: PAC SR # [REDACTED]

Hello Nancy,

\$623.00 plus tax is the preliminary estimate to replace the damaged part that I see in the pic. We will need to schedule the vehicle in for further inspection of the cause. The vehicle also has 2 outstanding recalls on it unrelated.

Todd Bitzel  
Byers Chevrolet  
Service Manager  
614-228-1551  
[tbitzel@byersauto.com](mailto:tbitzel@byersauto.com)  
[www.byerschevy.com](http://www.byerschevy.com)

---

From: Nancy Novak (C) [<mailto:nancy.novak@gm.com>]  
Sent: Thursday, June 18, 2015 10:19 AM  
To: Howard Bitzel (Byers Chevrolet Llc)  
Subject: PAC SR [REDACTED]

Hi Todd,

GM has performed a preliminary investigation on the fuse box for the customer below. I have attached the pictures showing her current vehicle issue. At this point, GM is looking for a dealer to work with on this PAC claim. Our next step is to obtain a repair estimate. The vehicle would be brought to your dealership for you to verify damage and create a repair estimate. Can you assist us with this claim? I can provide further information if necessary. Please call me.

Re [REDACTED]  
2003 Chevrolet TrailBlazer  
1GNDT13S932 [REDACTED]

Thank you,

**Nancy Novak**  
GM Product Assistance Claims  
Tel: 866.446.6963 ext 21628  
Fax: 866-255-3845  
[Nancy.Novak@GM.com](mailto:Nancy.Novak@GM.com)

Nothing in this message is intended to constitute an electronic signature unless a specific statement to the contrary is included in this message.

Confidentiality Note: This message is intended only for the person or entity to which it is addressed. It may contain confidential and/or privileged material. Any review, transmission, dissemination or other use, or taking of any action in reliance upon this message by persons or entities other than the intended recipient is prohibited and may be unlawful. If you received this message in error, please contact the sender and delete it from your computer.

Type of case	Fire Case	Case Summary
Status	New	<p>Allegation; I think it was the recalls on my vehicle that caused the smoke and melting then a small fire in the fuse box</p> <p>6/11/2015-Photos from the customer were added to SR.</p>
SR Number	[REDACTED]	
Customer Name (Last name/First Name)	[REDACTED]	
Year/Make/Model	2003/Chevrolet/Trailblazer	
VIN	1GNDT13S9324 [REDACTED]	
Incident Date	6/6/2015	
Purchase Date	9/1/2014	
Titled in who's name	[REDACTED]	
Purchase Price	unknown	
Open/Closed Recalls (If closed include closed Transaction History)	<p><i>Product Safety Recall N040087 04087 TAIL LAMPS/STOP LAMPS 11/16/2004 Open</i></p> <p><i>Noncompliance Recall N030039 03039 CHILD RESTRAINT ANCHORAGE SYSTEM INFORMATION 08/11/2003 Closed</i></p> <p><i>Product Safety Recall N050044 05044 INTERMITTENT INCORRECT TURN SIGNAL OPERATION 07/28/2005 Open</i></p>	
Mileage	170,000	
Purchased From	Non GM Dealer--Ford	
Vehicle Insured	Yes	
MSRP/KBB (Trade-in Good Value)	\$2,611.00	

Loaner Vehicle (yes/no from drop down and enter date issued)	No		
Additional Information as requested by TC/TL			



5887 N. Meadows Drive  
Grove City, OH 43123  
(614) 441-4912

www.byersauto.com Remit to: P.O. Box 16513 Columbus, OH 43216



CELL [REDACTED]

CUSTOMER NO. [REDACTED]	ADVISOR <b>BRIAN MILLER</b>	TAG NO. 493 1716	INVOICE DATE 07/14/15
[REDACTED]	LABOR RATE	LICENSE NO.	MILEAGE 168,774 /
[REDACTED]	YEAR / MAKE / MODEL 03/CHEVROLET TRUCK/TRAILBLAZER/4DR 4	VEHICLE I.D. NO. 1 G N D T 1 3 S 9 3 2	COLOR
[REDACTED]	F.T.E. NO.	P.D. NO.	R.O. DATE 06/23/15
RESIDENCE PHONE	BUSINESS PHONE	COMMENTS	

MO: 168775

**LABOR & PARTS**

JOB # 1 54CVZ

TECH#	DATE	START	FINISH	ACT	TIME	DESCRIPTION
405	06/23/15	13.80	14.00	0.20	0.00	HOLD AUTHORIZATION
405	06/26/15	8.50	9.30	0.80	0.00	HOLD OTHER
405	06/26/15	17.20	17.20	0.00	0.00	FINISHED
405	06/26/15	0.00	0.00	0.00	2.50	FINISHED
TOTAL TECH TIME				1.00	2.50	

CUSTOMER STATES VEHICLE CAUGHT FIRE UNDER HOOD, POSSIBLE HEADLIGHT FUSE BURNED. INSPECT FUSE PANEL BURNT AND MELTED AT HEADLAMP RELAY. UNKNOWN CAUSE. PER GM CHECK CONNECTION C2 PIN D5 ORANGE AND CIRCUIT 140 BATTERY POSITIVE VOLTAGE. ALL SEEM OK. NEED TO INSTALL NEW FUSE PANEL TO FURTHER TEST. REPLACE UNDER HOOD FUSE PANEL AND CHECK HEADLAMP AND TURN SIGNAL OPERATION-ALL GOOD AT THIS TIME. NOTE: OIL CHANGE MESSAGE, CEL ON, STEERING SHAKES WHILE DRIVING



www.byersauto.com

SEE REVERSE SIDE FOR IMPORTANT WARRANTY INFORMATION

PARTS	QTY	FP	NUMBER	DESCRIPTION	U/COST	E/COST	U/PRICE
JOB # 1	1		15196420	BLOCK Y 2.483	258.09	258.09	361.33
JOB # 1 COST TOTAL					258.09		
JOB # 1 TOTAL PARTS							361.33
JOB # 1 TOTAL LABOR & PARTS							516.56

JOB # 2 04CVZ

TECH#	DATE	START	FINISH	ACT	TIME	DESCRIPTION
405	06/23/15	14.00	14.10	0.10	0.00	HOLD AUTHORIZATION
405	06/26/15	17.20	17.20	0.00	0.00	FINISHED
405	06/26/15	0.00	0.00	0.00	0.30	FINISHED
TOTAL TECH TIME				0.10	0.30	

RECALL 04087. INSPECT CIRCUIT BOARDS, RIGHT SIDE LAMP BROKEN AT RETAINER SCREWS, NEEDS NEW LAMP HOUSING. RIGHT BACK UP OUT. REPLACE LEFT CIRCUIT BOARD AND STOP LAMP BULB, ALSO REPLACE RIGHT TAIL LAMP ASSEMBLY

PARTS	QTY	FP	NUMBER	DESCRIPTION	U/COST	E/COST	U/PRICE
JOB # 2	1		16532713	BOARD Y 2.694	17.78	17.78	24.89
JOB # 2	1		15231201	FLASHER Y 2.575	30.93	30.93	43.30
JOB # 2	1		12450108	BULB Y 2.679	2.04	2.04	2.86
JOB # 2	1		15131579	LAMP N 2.679	63.44	63.44	88.82
JOB # 2 COST TOTAL					114.19		
JOB # 2 TOTAL PARTS							159.87
JOB # 2 TOTAL LABOR & PARTS							188.98

JOB # 3 04CVZ10023

TECH#	DATE	START	FINISH	ACT	TIME	DESCRIPTION
405	06/23/15	14.10	14.10	0.00	0.00	HOLD AUTHORIZATION
405	06/26/15	17.20	17.20	0.00	0.00	FINISHED
405	06/26/15	0.00	0.00	0.00	0.20	FINISHED
TOTAL TECH TIME				0.00	0.20	

The Reynolds and Reynolds Company - EMEA - PHOENIX - DC3178210 (10/10)



5887 N. Meadows Drive  
Grove City, OH 43123  
(614) 441-4912

www.byersauto.com Remit to: P.O. Box 16513 Columbus, OH 43216



CUSTOMER NO.	ADVISOR <b>BRIAN MILLER</b>	TAG NO. <b>493 1716</b>	INVOICE DATE <b>07/14/15</b>
RESIDENCE PHONE	LABOR RATE	LICENSE NO.	MILEAGE <b>168,774</b>
BUSINESS PHONE	YEAR / MAKE / MODEL <b>03/CHEVROLET TRUCK/TRAILBLAZER/4DR 4</b>	DELIVERY DATE	DELIVERY MILES
COMMENTS	VEHICLE I.D. NO. <b>1 G N D T 1 3 S 9 3 2</b>	SELLING DEALER NO.	PRODUCTION DATE
	F.T.E. NO.	R.O. DATE <b>06/23/15</b>	

MO: 168775

LABOR & PARTS									
RECALL 05044									
REPLACE TURN SIGNAL FLASHER.									
								JOB # 3 TOTAL LABOR & PARTS	19.40
								R/O TAX	0.00
								R/O TOTALS	724.94
CLAIM TOTALS	0.00	0.00	0.00	0.00	0.00	0.00	0.00	0.00	0.00

www.byersauto.com

SEE REVERSE SIDE FOR IMPORTANT WARRANTY INFORMATION

APPROVED BY SIGNATURE  
\*\*\*\*\* PRE - INVOICE \*\*\*\*\*



www.byersauto.com

Doc U. Schwabert, Service M



www.byersauto.com



5887 N. Meadows Drive
Grove City, OH 43123
(614) 441-4912

RECOMMENDED SERVICES

Table with 8 columns: OPERATION, OPERATION DESCRIPTION, MO/MI, TOTAL, OPERATION, OPERATION DESCRIPTION, MO/MI, TOTAL. Row 1: 01CVZ100, 100K MINIMUM SERVICE, MI, 271.80

SERVICE HISTORY

Table with 8 columns: DATE, REPAIR ORDER, MILEAGE, ADVISOR, TECHNICIAN, TYPE, OPERATION, OPERATION DESCRIPTION

SALESPERSON NO. SERVICE STATE REG# 3

Vehicle information form including VIN (1GNDT13S932), Year/Make/Model (03/CHEVROLET TRUCK/TRAILBLAZER/4DR), Mileage (168,774), and Advisor (BRIAN MILLER)

Job description and estimate form. Job 1: C 54CVZ BODY ELECTRICAL. Job 2: W 04CVZ GM RECALLS. Job 3: W 04CVZ10023 RECALL 10023. Includes customer estimate and technician notes.

Reynolds and Reynolds ERM/NTV/D/GE C02616303 Q (06/06)

ST66724 Q (03/15)



Close Window

# Edit Transaction Pre-Repair Authorization

PRINT-FRIENDLY VERSION

This screen allows the user to edit existing Pre-Repair Authorization.

Business Unit\*: GM - US

Transaction Type\*: ZREG—Regular Vehicle Transaction

Pre-Repair Type: Repair Authorization

## Pre-Repair Authorization

Pre-Repair Auth ID: [Redacted]

Original Author: Megan Smith

New Author: Megan Smith

\*Required Fields  
Disclaimer: All amounts are before taxes

BAC\*: 112811

Service Agent: BYERS CHEVROLET, LLC

Contact Name: [Redacted]

Phone Number: [Redacted]

Fax Number: [Redacted]

Contact Email Address: [Redacted]

Job Card\*: [Redacted]

Job Card Date: 07/14/2015

Reference Number: [Redacted]

VIN: 1GNDT13S93 [Redacted] [Investigate Vehicle History](#)

Odometer: 168774

- Transaction Flag:
- Customer Enthusiasm - Non Warrantable Repair
  - Special Coverage
  - Policy
  - None

Customer Complaint Category\*: 09—No Customer Complaint

Complaint Code\*: 0090—No Customer Complaint - Other issues

Description: \* No customer complaint - Other issues

Cause Code\*: 9090 , Other - Field Action / Tech Bulletin

Description\*: Other - Field Action/Tech Bulletin

Correction Description\*: Repair Vehicle

Labour Operation\*: 0600006

Labour Time: 1.6 Supp Time: 0 OLH Time: 0

Labour Rate: 97.02 Common GM Division - Mechanical

Labour Total: 155.23

Parts Total: 361.33

Part Numbers:

Net Item Type	Amount
<Make Selection>	<input type="text"/> <input type="button" value="+"/> <input type="button" value="-"/>
Net Item Total:	<input type="text" value="0.00"/>
Tax:	<input type="text" value="0"/>
Deductible:	<input type="text" value="0"/>
Total Before Taxes:	<input type="text" value="516.58"/>
Auth Code:	<input type="text"/>

Accept  Reject

Comment\*:

Created By	Create Date/Time	Comment
Megan Smith	Wed Jul 15 09:48:16 EDT 2015	Please attach the Pre-Auth ID when submitting the claim.

Reassign Comments: Created By Comment From Assigned To

Attachments:

No rows were found.

Attachment Id	Attachment Name	User Name

Browse...

ADD

DELETE

Pre Repair Authorization History:

VIN	Pre-Repair Authorization ID	Create Date
1GNDT13S93 [REDACTED]	[REDACTED]	2015-07-15

CANCEL

SAVE

Nancy Novak (C)

---

From: Nancy Novak (C)  
Sent: Wednesday, July 15, 2015 10:23 AM  
To: 'tbitzel@byersauto.com'  
Subject: PAC SR # [REDACTED] //Pre-Repair Authorization ID for payment using labor op 0600006

Upon receipt of this pre-authorization for the above listed claim for payment, please verify that the information listed below is correct. Please make sure that it is the correct customer, VIN, mileage, BAC, Job Card#, Job Card close date and dollar amount.

If everything is correct, please submit a "Pre Authorization Claim" (NOT a GM Authorization claim). The system will then prompt the Service Agent to enter the Pre-Repair Authorization ID and list all of the associated part numbers, labor hours, and other expenses that may have been approved. Please utilize the appropriate Net item types as applicable (Car Rental/Hire, Towing, Sublet, etc). The pre-authorization # is listed below. If this claim rejects, please contact the Warranty Support Center at 1-866-446-5900.

Servicing Dealer BAC: 112811  
Dealer Contact: Todd Bitzel  
Email: Todd Bitzel <[tbitzel@byersauto.com](mailto:tbitzel@byersauto.com)>  
Dealer Fax: N/A  
Job Card number: [REDACTED]  
Job Card Date: 7/14/2015  
VIN: 1GNDT13S932 [REDACTED]  
Odometer: 168774  
Labor Op: 0600006  
Labor Time (hrs) estimate: 1.6  
Dealer's mechanical warranty rate per hr: 97.01  
Total labor estimate: 155.23  
Parts Total: 361.33  
Car Rental/Hire (if applicable): n/a  
Sublet (if applicable): n/a  
Claim total: 516.56

Customer Complaint Category: 09  
Complaint Code: 0090  
Description: No customer complaint – Other issues  
Cause Code: 9090  
Description: Other – Field Action/Tech Bulletin  
Correction Description: Repair Vehicle

Line before tax: \$516.56

Pre Authorization ID: [REDACTED]0

Please attach the Pre-Auth ID when submitting the claim.

Thank you for your help,

**Nancy Novak**

GM Product Assistance Claims

Tel: 866.446.6963 ext 21628

Fax: 866-255-3845

[Nancy.Novak@GM.com](mailto:Nancy.Novak@GM.com)

**Customer**

[Redacted]  
 [Redacted]  
 Call Anytime

**Vehicle**

2007 Chevrolet Trailblazer  
 1GNDT13S072 [Redacted]  
 Mileage now: 50000 mi

**Status of vehicle/concern**

A GM Dealer has diagnosed the current concern  
 Repairs have not been scheduled  
 Vehicle is currently operable & can be driven

**Key Points**

Cust sts: Took vehicle to dealership yesterday/ they stated we would have to pay for the repair/ and another hour of diagnostic/ they are stating that it is the backup light/ that my son hooked up/ may have caused and issue/ but he checked it and it is not wired to the main circuit harness/ there was a shortage in the wire/ that caused the relay to melt/ I think this should be covered/ there was nothing I did to cause this issue.

Cust sks: Repair to be covered/ or assistance to have repair made.

Supporting Factors	Limiting Factors
Original owner (verified)  Loyal GM customer: 5 GM vehicles purchased (verified)  Vehicle has been serviced for this concern: 1 time(s)	
<p><i>Please consider these additional questions:</i>                      Close to any applicable expiration limit? (wrnty, spl covg, svc contrt)                      Did cust buy an extd svc contract, but it's expired or n/a?                      Is this a loyal service customer? (to involved dealer)                      Are high dollar customer-pay ROs on record for this cust?                      Is this a conquest buyer?</p>	<p><i>Please consider these additional questions:</i>                      Is vehicle way beyond all applicable expiration limits?                      Does veh have an active <u>aftermarket</u> Extd Svc Contract?                      Did customer buy vehicle outside of warranty?                      Does it seem customer doesn't take care of the vehicle?                      Is cause not normally covered by warranty?                      Is cause due to an accident insurance won't cover?                      Is cause due to damage by independent repair facility?</p>

**Additional key points**

This customer has purchased these GM vehicles (verified): 1989 Grand AM/ 1989 Sierra/ 1996 C/K Pickup/ 2000 Blazer/ 2007 Trailblazer

**Reference**

[Redacted]  
 CAC advisor: Tracy--> (866) 790-5700, Ext # 21656

## Stephanie Washington (C)

---

From: Mickey Sabol  
Sent: Tuesday, June 23, 2015 12:22 PM  
To: Stephanie Washington (C)  
Cc: Kimberly Horvath (C)  
Subject: Smoke Case SR# [REDACTED] need more photos

Hi Stephanie,

I have reviewed the case and photos and the photos are insufficient. I need more photos. The photos of the fusebox do not actually shows the fuses and relays. I have provided an example photo of what I need below. While you are at it, please ask if they were experiencing any problems with their headlight.

Thanks,

Mickey



---

From: Stephanie Washington (C)  
Sent: Tuesday, June 23, 2015 11:58 AM

To: Mickey Sabol; Kimberly Horvath (C)  
 Subject: Smoke Case SR# 71-1489486821

Mickey,

Type of case	Smoke Case	Allegation/Synopsys
Status	Photos	Customer alleges his wife went to p their 18 month old and 4 year old g and had made it back home, he too year old to pick strawberry's his wi 18 month old in the house within 1 she saw where the vehicle was sm underneath the hood, she went ou the vehicle started by itself while it smoking and struggled to stay start the smoke started to lessen and wa its own. The fuse box is melted.
SR Number	[REDACTED]	
Customer Name	[REDACTED]	
Year/Make/Model	2002/Chevrolet Trailblazer	
VIN	1GNDT13S222 [REDACTED]	
Incident Date	6/16/2015	
Purchase Date	2/2/2002	
Titled in who's name	William Borer	
Purchase Price	25,000	
Open/Closed Recalls	<p><i>Customer Satisfaction Program N030013            03013 INSTRUMENT PANEL CLUSTER GAUGES            INOPERATIVE 05/22/2003 Closed</i></p> <p><i>Noncompliance Recall N030012 03012 TRANSMISSION            SHIFT LOCK AND IGNITION KEY REMOVAL OVERRIDE            COMPLIANCE 05/21/2003 Closed</i></p> <p><i>Product Safety Recall N040005 04005 WINDSHIELD            WIPER MOTOR FAILURE 07/06/2004 Closed</i></p> <p><i>Product Safety Recall N020016 02016 FUEL FILTER            FITTING DISCONNECT 05/07/2002 Closed</i></p> <p><i>Noncompliance Recall N040037 04037 FRONT SEAT            BELT RETRACTOR NONCOMPLIANCE 06/17/2004            Closed</i></p> <p><i>Customer Satisfaction Program N030013            03013 INSTRUMENT PANEL CLUSTER GAUGES            INOPERATIVE 05/22/2003 Closed</i></p> <p><i>Noncompliance Recall N030012 03012 TRANSMISSION            SHIFT LOCK AND IGNITION KEY REMOVAL OVERRIDE            COMPLIANCE 05/21/2003 Closed</i></p> <p><i>Product Safety Recall N040005 04005 WINDSHIELD            WIPER MOTOR FAILURE 07/06/2004 Closed</i></p> <p><i>Product Safety Recall N020016 02016 FUEL FILTER            FITTING DISCONNECT 05/07/2002 Closed</i></p> <p><i>Noncompliance Recall N040037 04037 FRONT SEAT            BELT RETRACTOR NONCOMPLIANCE 06/17/2004            Closed</i></p> <p><i>Customer Satisfaction Program N030013            03013 INSTRUMENT PANEL CLUSTER GAUGES            INOPERATIVE 05/22/2003 Closed</i></p> <p><i>Noncompliance Recall N030012 03012 TRANSMISSION</i></p>	

	<p>SHIFT LOCK AND IGNITION KEY REMOVAL OVERRIDE COMPLIANCE 05/21/2003 Closed</p> <p>Product Safety Recall N040005 04005 WINDSHIELD WIPER MOTOR FAILURE 07/06/2004 Closed</p> <p>Product Safety Recall N020016 02016 FUEL FILTER FITTING DISCONNECT 05/07/2002 Closed</p> <p>Noncompliance Recall N040037 04037 FRONT SEAT BELT RETRACTOR NONCOMPLIANCE 06/17/2004 Closed</p> <p>Customer Satisfaction Program N030013 03013 INSTRUMENT PANEL CLUSTER GAUGES INOPERATIVE 05/22/2003 Closed</p> <p>Noncompliance Recall N030012 03012 TRANSMISSION SHIFT LOCK AND IGNITION KEY REMOVAL OVERRIDE COMPLIANCE 05/21/2003 Closed</p> <p>Product Safety Recall N040005 04005 WINDSHIELD WIPER MOTOR FAILURE 07/06/2004 Closed</p> <p>Product Safety Recall N020016 02016 FUEL FILTER FITTING DISCONNECT 05/07/2002 Closed</p> <p>Noncompliance Recall N040037 04037 FRONT SEAT BELT RETRACTOR NONCOMPLIANCE 06/17/2004 Closed</p>
Mileage	116,000
Purchased From	Yark Chevrolet
Vehicle Insured	Yes
MSRP/KBB	\$2,366.00

Additional Information as requested by TC/TL

Thanks,

**Stephanie D. Washington**  
 General Motors Business Resource Center  
 Product Assistance Claims Department  
[stephanie.1.washington@gm.com](mailto:stephanie.1.washington@gm.com)  
 P 866.446.6963 ext. 11723  
 F 866.715.8521





Popular at KBB.com  
15 Best Family Cars of 2015

Advertisement

Why ads?

Home > Car Values > Chevrolet > TrailBlazer > 2002 > Style > Options > Sport Utility 4D

Chevrolet TrailBlazer 2002 Go

# Your Blue Book® Value

Show Used Car Prices | Price Your Next Car



## 2002 Chevrolet TrailBlazer

Style: Sport Utility 4D

Edit options | Check specs

Mileage: 116000 Change Live 64

Trade In to a Dealer

Get an Instant Cash Offer

Sell to a Private Party

Print report



Good Condition

Trade-in Values valid for your area through 6/25/2015  
Track this car's values

### Price a New Car

Then browse reviews, photos, specs and more.

See what you should pay

### Instant Cash Offer

Find local dealers ready to buy your car - today!

Get your offer

backed by

### Tell Us About This Car

Owners like you rated the 2002 TrailBlazer 8.2

Write your own review

Recently Viewed Cars | My Saved Cars Save car



## Next Steps to Selling Your Car

### Benchmark Local Prices

See what dealers and private sellers in your area are asking for your car.

See listings

### Give Buyers Confidence

Show them a clean AutoCheck vehicle history report and close the deal fast.

Enter VIN (optional) Go

### List It for Sale

Reach millions of in-market shoppers on KBB.com and AutoTrader.com.

Place your ad

Advertisement

Why ads?

### Free Dealer Price Quote

Get the best price and be more prepared with your free, no-obligation price quote

**SHOPPING TOYOTA?**  
 SEARCH THE  
**LARGEST SELECTION**  
 OF INVENTORY  
**CLICK HERE**

Advertisement

Why ads?

Search: Find car values or features

[Popular Topics](#)  
[New Cars for 2015](#)  
[Used Cars](#)  
[Cars for Sale](#)  
[Best Resale Value Awards](#)  
[Brand/Make Awards](#)

[Car Reviews & News](#)  
[Car Reviews](#)  
[Car Videos](#)  
[Auto Shows](#)  
[Car News](#)  
[Best Cars](#)

[Help](#)  
[FAQ](#)  
[Site Map](#)  
[Find a New Car](#)  
[What's My Car Worth](#)  
[KBB Mobile](#)

[Company](#)  
[About Us](#)  
[Contact Us](#)  
[Jobs](#)  
[Corporate Information](#)

[Industry Relations](#)  
[Advertising](#)  
[Media Center](#)  
[Linking Policy](#)  
[Business Solutions](#)

[Follow KBB](#)
[Facebook](#)
[Twitter](#)
[Google+](#)
[YouTube](#)
[LinkedIn](#)
[RSS](#)
[Mobile Apps](#)
[iPhone](#)
[Android](#)

© 1995-2015 Kelley Blue Book Co., Inc. All rights reserved. Copyright & Trademarks | Terms of Service | Privacy Policy | Ad Choices

Have comments about our Blue Book Values? Give us your feedback.

© 2015 Kelley Blue Book Co., Inc. All rights reserved. 6/19/2015-6/25/2015 Edition for Ohio 43623. The specific information required to determine the value for this particular vehicle was supplied by the person generating this report. Vehicle valuations are opinions and may vary from vehicle to vehicle. Actual valuations will vary based upon market conditions, specifications, vehicle condition or other particular circumstances pertinent to this particular vehicle or the transaction or the parties to the transaction. This report is intended for the individual use of the person generating this report only and shall not be sold or transmitted to another party. Kelley Blue Book assumes no responsibility for errors or omissions. (v.15063)





PRECAUTIONS  
DO NOT  
SMOKE  
OR  
FUMES  
DANGER  
ELECTRICITY  
WATER  
REPAIR  
INSTRUCTIONS

















ZIP CODE: 43623 | Sign in (or Sign up)

- Home
- Car Values
- Cars for Sale
- Car Reviews
- Awards & Top 10s
- Research Tools

Popular at KBB.com

Midsize SUV Buyer's Guide

See Special Offer

Advertisement

Why ads?

Home > Car Values > Chevrolet > TrailBlazer > 2002 > Style > Options > Sport Utility 4D

Chevrolet  TrailBlazer  2002

# Your Blue Book® Value

Show Used Car Prices | Price Your Next Car



## 2002 Chevrolet TrailBlazer

style:

[Edit options](#) | [Check specs](#)

Mileage:

[Change](#)

Like

[Trade In to a Dealer](#)

[Get an Instant Cash Offer](#)

[Sell to a Private Party](#)

[Print report](#)



### Next Step: Find a Car

**MONTH - LIFE INSURANCE**

The affordable-life-insu... tos,

New 2015

Discounts. Save d pay

5% - 75%. See if

You Qualify

Instantly (Free) er

Fin i buy

you

Advertisement

[Get your offer](#)

Advertisement

Why ads?

Advertisement

Why ads?

[START DOWNLOAD](#)

ugh 7/9/2015

Search Videos & Articles to Find How to Do it Yo

[Recently Viewed Cars](#)

[My Saved Cars](#)

[Save car](#)



### Tell Us About This Car

Owners like you rated the 2002 TrailBlazer 8.2 out of 10.

[Write your own review](#)

### Next Steps to Selling Your Car

#### Benchmark Local Prices

See what dealers and private sellers in your area are asking for your car.

[See listings](#)

#### Give Buyers Confidence

Show them a clean AutoCheck vehicle

history report and close the deal fast.

### List It for Sale

Reach millions of in-market shoppers on KBB.com and AutoTrader.com.

Place your ad

## Free Dealer Price Quote

Get the best price and be more prepared with your free, no-obligation price quote

Chevrolet

Model

ZIP Code 43623

Get your quote

Advertisement

Advertisement

Why ads?

Why ads?

Search: Find car values or features

#### Popular Topics

- New Cars for 2014
- Used Cars
- Cars For Sale
- Car Buying Guides
- Car Awards

#### Car Reviews & News

- Car Reviews
- Car Videos
- Auto Shows
- Car News
- Best Cars

#### Help

- FAQ
- Site Map
- Find a New Car
- What's My Car Worth
- KBB Mobile

#### Company

- About Us
- Contact Us
- Careers
- Corporate Information

#### Industry Relations

- Advertising
- Media Center
- Linking Policy
- Business Solutions

Follow KBB

Facebook

Twitter

Google+

YouTube

LinkedIn

RSS

Mobile Apps

iPhone

Android

© 1995-2015 Kelley Blue Book Co., Inc. All rights reserved. Copyright & Trademarks | Terms of Service | Privacy Policy | Ad Choices

Have comments about our Blue Book Values? Give us your feedback.

© 2015 Kelley Blue Book Co., Inc. All rights reserved. 7/2/2015-7/9/2015 Edition for Ohio 43623. The specific information required to determine the value for this particular vehicle was supplied by the person generating this report. Vehicle valuations are opinions and may vary from vehicle to vehicle. Actual valuations will vary based upon market conditions, specifications, vehicle condition or other particular circumstances pertinent to this particular vehicle or the transaction or the parties to the transaction. This report is intended for the individual use of the person generating this report only and shall not be sold or transmitted to another party. Kelley Blue Book assumes no responsibility for errors or omissions. (v.15071)



FedEx Kinko's is now FedEx Office

# Fax Cover Sheet

Date July 8<sup>th</sup> 2015

Number of pages 7 (including cover page)

To:

Name Stephanie

Company GM

Telephone 866-446-6963

Fax 866-476-8007

From:

Name 

Company 

Telephone 

Comments \_\_\_\_\_  
\_\_\_\_\_  
\_\_\_\_\_



fedex.com 1.800.GoFedEx 1.800.463.3339

**RELEASE AND INDEMNIFICATION OF ALL CLAIMS****FILE NUMBER:** [REDACTED]**KNOW ALL MEN BY THESE PRESENTS:**

The undersigned [REDACTED] being of lawful age, as buyer(s) of a certain **2002, Chevrolet, Trailblazer** bearing Vehicle Identification Number **1GNDT13S222** [REDACTED] (hereinafter referred to as "Vehicle"), for the sole consideration of **Three Thousand Five Hundred Dollars, \$3,500.00** to the undersigned in hand paid, receipt whereof is hereby acknowledged, does hereby and for my heirs, executors, administrators, successors and assigns, release, acquit, and forever discharge **General Motors LLC**, and its agents, servants, successors, heirs, executors, administrators and all other persons, firms, suppliers, corporations, associations or partnerships, the "Releases", of and from any and all claims, causes of action, demands, rights, damages, costs, loss of service, expenses and compensation whatsoever, which the undersigned now has/have, or which may hereafter accrue on account of, or in any way growing out of, any and all known and unknown, foreseen and unforeseen bodily, personal injury and property damage, and the consequences thereof resulting to or resulting from the accident, casualty or event which occurred on or about the **16, June, 2015** at or near **customers driveway, [REDACTED] in Toledo Ohio.**

It is understood and agreed that this settlement is the compromise of a doubtful and disputed claim, and that the payment made is not to be construed as an admission of liability on the part of the party or parties hereby released, and that said Releases deny liability therefore and intend merely to avoid litigation and buy their peace.

The undersigned hereby declare(s) and represent(s) that the injuries sustained are, or may be, permanent and progressive and that recovery therefrom is uncertain and indefinite, and in making this Release, it is understood and agreed, that the undersigned relies wholly upon the undersigned's own judgment, belief and knowledge of the nature, extent, affect and duration of said injuries and liability therefore, and it is made without reliance upon any statement or representation of the party or parties hereby released, or their representatives, or by any physician or surgeon by them employed.

It is understood and agreed that this Release is intended to cover, and does cover, without limitation, claims which are known and unknown, claims for known and unknown injuries, and/or damage claims for anticipated or unanticipated injuries and/or damage; and claims for expected or unexpected consequences of injuries and/or damages, which have resulted or may result from any alleged conduct, acts, or omissions of any of the Releases.

It is understood and agreed that the undersigned, his/her heirs, executors, administrators, and assigns does agree to indemnify, save harmless and defend the Releases from all claims and demands for damages, costs, expense or compensation on account of, or in any way arising out of the accident, casualty or event which occurred on or about **customers driveway, [REDACTED] in Toledo Ohio**, including actual damages, actual attorney's fees and all other costs arising out of claims for contribution and/or common law indemnification, and/or contractual indemnification brought against the Releases by any person whatsoever.

It is further understood that this settlement is a confidential settlement, the terms of which will not be disclosed to any third person except as required by law.

The undersigned further declare(s) and represent(s) that no promise, inducement or agreement not herein expressed has been made to the undersigned, and that this Release contains the entire agreement between the parties hereto, and that the terms of this Release are contractual and not mere recital.

FILE NUMBER: [REDACTED]

ANY PERSON WHO, WITH INTENT TO DEFRAUD OR KNOWING THAT HE IS FACILITATING A FRAUD AGAINST AN INSURER, SUBMITS AN APPLICATION OR FILES A CLAIM CONTAINING A FALSE OR DECEPTIVE STATEMENT, IS GUILTY OF INSURANCE FRAUD.

THE UNDERSIGNED HAS READ THE FOREGOING RELEASE AND FULLY UNDERSTANDS IT.

CAUTION: READ BEFORE SIGNING

[REDACTED]	[REDACTED]
CUSTOMER PRINTED NAME	CUSTOMER SIGNATURE
WITNESS	WITNESS

State of Ohio }

County of Lucas }

On the 8th day of July, 2015, before me personally appeared

[REDACTED] to me known to be the person(s) named herein and who executed the foregoing Release and he/she/they acknowledged to me that he/she/they voluntarily executed the same.

My term expires March 23, 2019

[Signature]  
Notary Public



AUTUM TORNAJ  
NOTARY PUBLIC - OHIO  
MY COMMISSION EXPIRES March 23, 2019



# OHIO CERTIFICATE OF TITLE

COUNTY OF LUCAS STATE OF OHIO No. 201501150001

IDENTIFICATION NUMBER [REDACTED] OWNER CHEVROLET CHEVROLET



VEHICLE MAKE AND MODEL CHEVROLET PONTIAC INC VIN 481262143 481262143 481262143

VOID IF ALTERED

VOID IF ALTERED

**LIEN CANCELLED**  
JAN 26 2007  
BERNIE QUILTER, Clerk

WITNESS MY HAND AND OFFICIAL SEAL



505336570

**DO NOT ACCEPT TITLE SHOWING ANY ERASURES, ALTERATIONS OR MUTILATIONS.**

BMV 3800 Rev. 8/98

VEHICLE INVOICE



Don Scott Chevrolet-Pontiac

9830 State Rte. 64 P. O. Box 2867

Telephone 878-9055 1-800-767-2688

Whitehouse, Ohio 43071



SOLD TO:



DATE 01/08/02

ADDRESS:

SALESMAN ANDREW J SZYMANSKI 397 TOLEDO OH 4

MAKE	MODEL	NEW OR USED	VIN	YEAR	KEY NO.															
2002 CHEVROLET	TRAILBLAZER TRUCK	N	1GNDT13S22234301X		S867															
<p><b>PRICE OF VEHICLE</b> 26293.95</p> <p><b>OPTIONAL EQUIP. &amp; ACCESS</b> N/A</p>																				
<p><b>INSURANCE COVERAGE INCLUDES:</b></p> <p><input type="checkbox"/> FIRE AND THEFT <input type="checkbox"/> PUBLIC LIABILITY - AMT.</p> <p><input type="checkbox"/> COLLISION - AMT. DEDUCT. <input type="checkbox"/> PROPERTY DAMAGE - AMT.</p>																				
<p><b>OPTIONAL EQUIPMENT AND ACCESSORIES</b></p> <table border="1"> <thead> <tr> <th>GROUP</th> <th>DESCRIPTION</th> <th>PRICE</th> </tr> </thead> <tbody> <tr> <td></td> <td>THE _____</td> <td></td> </tr> <tr> <td></td> <td>_____</td> <td></td> </tr> <tr> <td></td> <td>_____</td> <td></td> </tr> <tr> <td></td> <td>_____</td> <td></td> </tr> </tbody> </table> <p>ON THIS VEHICLE IS NOT SUPPLIED, MARKETED, OR WARRANTED BY GENERAL MOTORS.</p>						GROUP	DESCRIPTION	PRICE		THE _____			_____			_____			_____	
GROUP	DESCRIPTION	PRICE																		
	THE _____																			
	_____																			
	_____																			
	_____																			
<p><b>SALES TAX</b> 1643.37</p> <p><b>LICENSE AND TITLE</b> 24.75</p> <p><b>TOTAL CASH PRICE</b> 27962.07</p>																				
<p><b>EXTENDED WARRANTY</b> N/A</p> <p><b>FINANCING</b> N/A</p> <p><b>INSURANCE</b> N/A</p> <p><b>TOTAL TIME PRICE</b> 27962.07</p>																				
<p><b>SETTLEMENT:</b></p> <p><b>REBATE</b> 2002.00</p> <p><b>DEPOSIT</b> 100.00</p> <p><b>CASH ON DELIVERY</b> 100.00</p> <p><b>TRADE-IN</b> N/A</p> <p><b>LESS LIEN</b> N/A</p> <p><b>TYPE</b> N/A</p> <p><b>VIN</b> N/A</p> <p><b>PAYMENTS</b> 1 MOS @ N/A</p>																				
<p><b>TOTAL</b> 27962.07</p>																				

FORM SA-131N (1-97)  
Reynolds and Reynolds credit bureau: 800-368-6999 fax: 800-368-6999

THIS VEHICLE IS EQUIPPED WITH A GENERAL MOTORS ENGINE PRODUCED IN A GENERAL MOTORS PLANT OPERATED BY THE DIVISION.

OHIO BMV REGISTRATION CARD APPLICATION NO. [REDACTED]

LICENSE NO.	AGENCY NO.	ISSUE DATE	EXPIRATION DATE	WEIGHT	REG CODE (1)	
[REDACTED]	9995	07/23/2014	09/19/2015	0000000	CLASS PC	TYPE R
VEH. SERIAL NO.	VEH. YEAR	MAKE	VEH. TYPE	REG YEARS	CODE (2)	CODE (3)
1GNDY13S22[REDACTED]	2002	CHEV	SW	1	NR	
TITLE	DATE PURCHASED	SPECIAL PLATE		SEATING CAP.		
4801918605	01/11/2002					
ADDITIONAL NAME			TAXING DISTRICT	LOCAL TAX	TOTAL FEE	
[REDACTED]			4808	20.00	54.88	
OWNER ADDRESS			COUNTY	LEASE / TAX I.D. NO.		
[REDACTED]			LU48			
CITY / TOWNSHIP	POST OFFICE	STATE	ZIP	CONTROL NO.		
TOLEDO	TOLEDO	OH	[REDACTED]	[REDACTED]		
OLD APPLICATION	OLD PLATE					
[REDACTED]	AQ72UC					

OHIO BMV REGISTRATION CARD APPLICATION NO. 063139EL

LICENSE NO.	AGENCY NO.	ISSUE DATE	EXPIRATION DATE	WEIGHT	REG CODE (1)	
[REDACTED]	9995	07/23/2014	09/19/2015	0000000	CLASS PC	TYPE R
VEH. SERIAL NO.	VEH. YEAR	MAKE	VEH. TYPE	REG YEARS	CODE (2)	CODE (3)
1GNDY13S22[REDACTED]	2002	CHEV	SW	1	NR	
TITLE	DATE PURCHASED	SPECIAL PLATE		SEATING CAP.		
[REDACTED]	01/11/2002					
ADDITIONAL NAME			TAXING DISTRICT	LOCAL TAX	TOTAL FEE	
[REDACTED]			4808	20.00	54.88	
OWNER ADDRESS			COUNTY	LEASE / TAX I.D. NO.		
[REDACTED]			LU48			
CITY / TOWNSHIP	POST OFFICE	STATE	ZIP	CONTROL NO.		
TOLEDO	TOLEDO	OH	[REDACTED]	[REDACTED]		
OLD APPLICATION	OLD PLATE					
[REDACTED]	AQ72UC					

INSTRUCTIONS FOR APPLYING PLATE DECALS:

- 1) Verify plate number and decal match.
- 2) Do not moisten decal or apply at temperature less than 0 degrees F.
- 3) Clean and dry plate or previous decal before affixing new decal.
- 4) Remove decal by bending corner of card under decal along dotted line.
- 5) Next, lift up corner of decal where card is creased.
- 6) Decal is fragile, peel decal off slowly.
- 7) Place decal in lower right corner of rear plate. If plate has a previous decal attached, place new decal to cover old decal.
- 8) Rub or press firmly around edges of decal after applying.
- 9) See back side for further instructions.

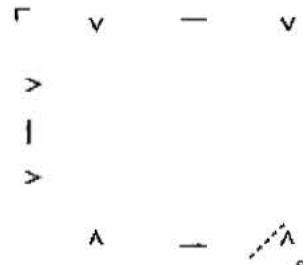

[REDACTED] 48 003714 T 01334 \*\*  
 TOLEDO OH [REDACTED]

OHIO CERTIFICATE OF TITLE

STATE OF OHIO

No. [REDACTED]

VEHICLE IDENTIFICATION NUMBER [REDACTED]

MAKE CHEVROLET

MODEL CHEVROLET

SALES TAX \$1,443.32

NET WEIGHT ACTUAL

OR REG - IN STATE



SELLER [REDACTED]

BUYER [REDACTED]

REGISTRATION FEE \$1.00

SALES TAX \$1,443.32

NET WEIGHT ACTUAL

4612624 - MOTORIST

LIEN CANCELLED

JAN 26 2007

Rec. No. BERNIE QUILTER, Clerk

WITNESS MY HAND AND OFFICIAL SEAL  
7052366520



[REDACTED]

*Bernie Quilter*

BERNIE QUILTER

CLERK OF COURTS

DO NOT ACCEPT TITLE SHOWING ANY ERASURES, ALTERATIONS OR

Ohio  
DRIVER LICENSE

TOLEDO, OH

CLASS: D EXPIRES: 09-19-2018

SEX: M HT: 5-00 WT: 180  
HAIR: BLU EYES: BLU

08-23

DRIVER





Friday, July 17, 2015

[Redacted]  
[Redacted]  
Toledo, OH [Redacted]

**Straight Settlement Letter**

Subject: Repurchase of 2002 Chevrolet TrailBlazer  
VIN: 1GN1T13S222 [Redacted]  
Ref SR [Redacted]

Dear [Redacted]:

We regret that you are dissatisfied with your 2002 Chevrolet TrailBlazer, VIN 1GN1T13S222 [Redacted] 8 and that our attempts to resolve your concerns have not met your expectations. Chevrolet will repurchase this vehicle in exchange for the release of liability stemming from warranties, express or implied, covering this vehicle.

This offer is being made in an effort to keep you a satisfied Chevrolet customer. Chevrolet will repurchase your vehicle for **\$3,500.00**. This offer was calculated by using the following figures:

Total Repurchase Amount	\$3,500.00
<b>Total Amount to Customer</b>	<b>\$3,500.00</b>

**\*\*AMOUNT IS SUBJECT TO CHANGE IF SIGNED PAPERWORK IS NOT RECEIVED BY DATE OUTLINED BELOW\*\***

**If you owe money to General Motors, please send certified check or money order made payable to General Motors.**

If this offer is acceptable, please sign this letter and return it to my attention via the fax number or address listed below. I will contact you to set up a signing date, at which time you will be required to complete the transaction.. I can be reached at **866-802-6625** x1203 if you have any questions or concerns.

---

Customer's and Co-Customer's Signature(s) and Date

---

Customer's and Co-Customer's Printed Name(s)

*The requirements of the straight repurchase are as follows:*

- ⇒ **Vehicle Damage** - vehicle is free from any abnormal damage, which impair its resale value. Vehicle must be inspected by a General Motors dealership at time of closing.
- ⇒ **Vehicle Alterations** - if this vehicle has been altered or modified from its original factory condition, it must be restored to its original condition before the scheduled repurchase appointment
- ⇒ **A "Power of Attorney" form** - supplied by General Motors must be signed and notarized at the time of repurchase (*used only for titling purposes*)
- ⇒ **An "Odometer Disclosure Statement" form** - supplied by General Motors must be signed at the time of the repurchase
- ⇒ **Factory installed equipment** – needs to be intact and functional.

\* [Redacted] \*



**CHEVROLET**

- ⇒ **Title** – if no lien, a free and clear title must be provided at time of repurchase.
- ⇒ **Cash backs rebates or incentives**– no cash backs rebates or incentives of any kind are applicable towards this transaction.

If all above requirements are met, the dealership will proceed with the repurchase and transfer of funds.

*Please return this signed document to fax number **866-802-6668** by Friday July 17, 2015*

Sincerely,

General Motors RVDC  
2717 Schust Rd  
Saginaw, MI 48603





July 14, 2015

**Dealer Confirmation Letter-Straight**

DAVE WHITE CHEVROLET, INC.  
5880 MONROE  
SYLVANIA, OH 43560

Subject: 2002 Chevrolet TrailBlazer

Customer: [REDACTED]

Ref SR [REDACTED]

Dear Darren Worth:

General Motors will issue a check in the amount of \$3,500.00 made payable to [REDACTED]. Please be sure to return the repurchase documents to General Motors RVDC immediately for completion of the repurchase. Do not wait for the final repair order. The repair order may be faxed once the repair has been completed.

Thank you for your cooperation.

Sincerely,

General Motors RVDC  
2717 Schust Rd  
Saginaw, MI 48603

**\*If you are aware of any modifications made to this vehicle, please contact your Repurchase Coordinator immediately. This vehicle must be restored to its original factory condition or the repurchase will be stopped and canceled.**

If you are in agreement with this offer, please sign and date below and return this agreement to my attention at the following fax # 866-802-6668 by Friday July 17, 2015. If you have any questions you may reach me at 866-802-6625 x1203.

---

DAVE WHITE CHEVROLET, INC. 115264 Management Agent's Signature and Title.

---

DAVE WHITE CHEVROLET, INC. 115264 Management Agent's Printed Name and Title.





**Case Number:** [REDACTED]

**Originator Name:** Stephanie Washington 866-790-5600 x 11723 stephanie.1.washington@gm.com

**Created Date:** 07/10/2015

**Vehicle Info**

**\*VIN:** 1GNDT13S22234 [REDACTED]

**Year:** 2002

**MSRP:** 0.0

**Make:** Chevrolet

**\*TAC #:** N/A

**Model:** TrailBlazer

**Vehicle Comments & TAC Explanation:**

**\*Date Reviewed with Customer:** 07/10/2015

**Original Purchase Date:** 01/01/1900

**\*Repurchase Mileage:** 116000

**\* Original Purchase Condition:** New

**Vehicle Owner(s)**

**Entity Type:** Person

**\* Names(s) on Title:** [REDACTED]

**\* Title State:** OH

**\* Primary Owner:** [REDACTED]

**\* Address:** [REDACTED]

**\* City:** Toledo

**\* State:** OH

**\* ZIP Code:** [REDACTED]

**\* Day Phone:** [REDACTED]

**\* Home Phone:**

**\* Cell Phone:** [REDACTED]

**\* E-mail:** [REDACTED]

**\* Fax Phone:**

**\* Reason Repurchase:** Fuse box caught fire

**UCC Codes** (N0409) Electrical - Fuse Block / Fuses / Relays - Fire

**Vehicle Lien Holder**

**Type of Secured Interest:** No Lien

**\* Company:**

**Account #:**

**Contact or Attention:**

**Address:**

**City:**

**State:**

**ZIP Code:**

**Day Phone:**

**Fax:**

**E-mail:**

**Original Selling Dealer**

**\* Dealer #:** 159204

**Dealer Name:** COLUMBIA CHEVROLET

**Region:** 50

**District:** 5112

**\* Phone:** (513) 891-7200

**Fax:** (513) 985-3511

**\* Contact Name:** Steve Minnich

**\* Contact Title:** Service Manager **E-Mail:** steve.minnich@jos..

**Repurchasing Dealer:**

**\* Dealer #:** 115264

**Dealer Name:** DAVE WHITE CHEVROLET, INC.

**Region:** 50

**District:** 5114

**\* Phone:** (419) 885-4444

**Fax:** (419) 824-7602

**\* Contact Name:** Darren Worth

**\* Contact Title:** Service Manager **E-Mail:** dworth@whitecars...

**Repair**

**\* Contact Name:**

**\* Contact Title:**

**Vehicle Location:**

**\* Dealer #:** 115264

**Dealer Name:** DAVE WHITE CHEVROL..

**Region:** 50

**District:** 5114

**\* Phone:** (419) 885-4444

**Fax:** (419) 824-7602

**\* Contact Name:** Darren Worth

**\* Contact Title:** Service Manager **E-Mail:** dworth@whitecars...



**Case Number:** 2 [REDACTED]  
**Originator Name:** Stephanie Washington 866-790-5600 x 11723 stephanie.1.washington@gm.com  
**Created Date:** 07/10/2015

**Transaction Details**

**Siebel Request #:** [REDACTED]      \* **Disposition:** Scrap  
**State:** OH      \* **Type:** Straight Repurchase  
**Source:** PAC Product Asst Claims Dept  
**Replacement VIN:** -  
**Compliance Date:**      \* **Compliance Type:**  
**MSRP:** 0.0      \* **Order #:**

**Repurchase:**      Srcap  
 \* **Processing Instructions:**

**Disposition:**      Scrap  
 \* **Processing Instructions:**

**Transaction Details**

<u>Group</u>	<u>Responsible</u>	<u>Formula</u>	<u>Additional Explanation</u>	<u>Value</u>
Usage	Use Lemon Law	NA	Usage per Lemon Law	0
Sales Tax	Customer	NA	Sales Tax	0
State/Gov Fees	Customer	NA	Fees	0
After Market Item(s)	Does Not Apply	NA	No Aftermarket Items	0
Negative Equity	Customer	NA	Negative Equity	0
Over Allowance Amount	Customer	NA	Over Allowance	0

**RELEASE AND INDEMNIFICATION OF ALL CLAIMS**

FILE NUMBER [REDACTED]

**KNOW ALL MEN BY THESE PRESENTS:**

The undersigned, [REDACTED] being of lawful age, as buyer(s) of a certain **2002, Chevrolet, Trailblazer** bearing Vehicle Identification Number **1GNDT13S22[REDACTED]** (hereinafter referred to as "Vehicle"), for the sole consideration of **Three Thousand Five Hundred Dollars, \$3,500.00** to the undersigned in hand paid, receipt whereof is hereby acknowledged, does hereby and for my heirs, executors, administrators, successors and assigns, release, acquit, and forever discharge **General Motors LLC**, and its agents, servants, successors, heirs, executors, administrators and all other persons, firms, suppliers, corporations, associations or partnerships, the "Releases", of and from any and all claims, causes of action, demands, rights, damages, costs, loss of service, expenses and compensation whatsoever, which the undersigned now has/have, or which may hereafter accrue on account of, or in any way growing out of, any and all known and unknown, foreseen and unforeseen bodily, personal injury and property damage, and the consequences thereof resulting to or resulting from the accident, casualty or event which occurred on or about the **16, June, 2015** at or near **customers driveway [REDACTED] in Toledo Ohio.**

It is understood and agreed that this settlement is the compromise of a doubtful and disputed claim, and that the payment made is not to be construed as an admission of liability on the part of the party or parties hereby released, and that said Releases deny liability therefore and intend merely to avoid litigation and buy their peace.

The undersigned hereby declare(s) and represent(s) that the injuries sustained are, or may be, permanent and progressive and that recovery therefrom is uncertain and indefinite, and in making this Release, it is understood and agreed, that the undersigned relies wholly upon the undersigned's own judgment, belief and knowledge of the nature, extent, affect and duration of said injuries and liability therefore, and it is made without reliance upon any statement or representation of the party or parties hereby released, or their representatives, or by any physician or surgeon by them employed.

It is understood and agreed that this Release is intended to cover, and does cover, without limitation, claims which are known and unknown, claims for known and unknown injuries, and/or damage claims for anticipated or unanticipated injuries and/or damage; and claims for expected or unexpected consequences of injuries and/or damages, which have resulted or may result from any alleged conduct, acts, or omissions of any of the Releases.

It is understood and agreed that the undersigned, his/her heirs, executors, administrators, and assigns does agree to indemnify, save harmless and defend the Releases from all claims and demands for damages, costs, expense or compensation on account of, or in any way arising out of the accident, casualty or event which occurred on or about **customers driveway, [REDACTED] in Toledo Ohio**, including actual damages, actual attorney's fees and all other costs arising out of claims for contribution and/or common law indemnification, and/or contractual indemnification brought against the Releases by any person whatsoever.

It is further understood that this settlement is a confidential settlement, the terms of which will not be disclosed to any third person except as required by law.

The undersigned further declare(s) and represent(s) that no promise, inducement or agreement not herein expressed has been made to the undersigned, and that this Release contains the entire agreement between the parties hereto, and that the terms of this Release are contractual and not mere recital.

FILE NUMBER [REDACTED]

ANY PERSON WHO, WITH INTENT TO DEFRAUD OR KNOWING THAT HE IS FACILITATING A FRAUD AGAINST AN INSURER, SUBMITS AN APPLICATION OR FILES A CLAIM CONTAINING A FALSE OR DECEPTIVE STATEMENT, IS GUILTY OF INSURANCE FRAUD.

THE UNDERSIGNED HAS READ THE FOREGOING RELEASE AND FULLY UNDERSTANDS IT.

CAUTION: READ BEFORE SIGNING

[REDACTED]	
CUSTOMER PRINTED NAME	CUSTOMER SIGNATURE
[REDACTED]	
WITNESS	WITNESS

State of Ohio }

County of Lucas }

On the 8th day of July, 2015, before me personally appeared

[REDACTED] to me known to be the person(s) named herein and who executed the foregoing Release and he/she/they acknowledged to me that he/she/they voluntarily executed the same.

My term expires March 23, 2019

[Signature]  
Notary Public



AUTUM TORNAJ  
NOTARY PUBLIC - OHIO  
MY COMMISSION EXPIRES March 23, 2019

# OHIO CERTIFICATE OF TITLE

COUNTY OF LUCAS

STATE OF OHIO

No. [REDACTED]

ISSUED TO  
01/17/2002

IDENTIFICATION NUMBER  
TGNDT13S23 [REDACTED]  
COMMENTS

PURCHASE PRICE  
\$25,255.95

YEAR MAKE MAKE DESCRIPTION  
2002 CHEV CHEVROLET  
SUB MODEL MODEL DESCRIPTION  
LAC TRAIL

CONVERSION

\$7,545.33  
MILES SHOWN ACTUAL

EXPIRES 196  
EVIDENCE OF REGISTRATION IN STATE

ISSUING

VEHICLE OF [REDACTED]

PREVIOUS OWNER  
DON SCOTT CHEVROLET PONTIAC INC

9630 SR 54  
WHITEHOUSE, OH 43574-0004

43126224 ND060087

FIRST LENDER DATE OF LEND 01/17/2002  
EIGHT FEDERAL CREDIT UNION

PO BOX 60349  
ROSSFORD OH 43450

LIEN DISCHARGE

LIEN DISCHARGE

Lienholder *Eight Federal Co*

Lienholder **LIEN CANCELLED**

by *Theresa Ann Quilter*  
Authorized signature

DATE JAN 26 2007  
Authorized signature

CLERK OF COURTS LIEN CANCELLATION

CLERK OF COURTS LIEN CANCELLATION

by *Bernie Quilter*  
Deputy Clerk

by **BERNIE QUILTER, Clerk**

WITNESS [REDACTED]

REAL SEAL THIS WILL EXPIRE JANUARY 2002 (SEAL)



\* [REDACTED] \*

J BERNIE QUILTER  
CLERK OF COURTS

DO NOT ACCEPT TITLE SHOWING ANY ERASURES, ALTERATIONS OR MUTILATIONS

VOID IF ALTERED

VOID IF ALTERED

ERASURES AND ALTERATIONS VOID THIS TITLE ASSIGNMENT. (Type or print in ink.)

**ASSIGNMENT OF OWNERSHIP**

I (we) certify the vehicle or watercraft or outboard motor described in this title was delivered on \_\_\_\_\_ for the price of \$\_\_\_\_\_ to: \_\_\_\_\_ Is Seller a Minor?  Yes  No

Transferee's/Buyer's printed name \_\_\_\_\_

Transferee's/Buyer's printed address \_\_\_\_\_

**ODOMETER CERTIFICATION**

Federal and state laws require that you state the mileage in connection with transfer of ownership. Failure to complete or providing false information may result in fines and/or imprisonment.

I (we) certify to the best of my (our) knowledge that the odometer now reads \_\_\_\_\_ and is the actual mileage of the vehicle unless one of the following statements is checked.

The mileage stated is in excess of the mechanical limits.  The odometer reading is not the actual mileage. **WARNING - ODOMETER DISCREPANCY**

This vehicle was a (if applicable):  Former Law Enforcement Vehicle  Former Taxi  Flood Vehicle

I (we) warrant the title to be free of all \_\_\_\_\_

Transferee's/Buyer's printed name \_\_\_\_\_ Transferee's/Buyer's signature \_\_\_\_\_

Transferee's/Buyer's printed address \_\_\_\_\_  
Toledo, Ohio \_\_\_\_\_

**NOTE: All blank spaces above must be completed before acknowledgement.**

Sworn to and subscribed in my presence by \_\_\_\_\_ this \_\_\_\_\_ day of \_\_\_\_\_ yr.

My commission expires \_\_\_\_\_ yr.  
(seal) Clerk, Deputy Clerk of Courts - Notary \_\_\_\_\_

**TRANSFEREE'S/BUYER'S ACKNOWLEDGMENT OF ABOVE ODOMETER CERTIFICATION**

Transferee's/Buyer's printed name \_\_\_\_\_ Transferee's/Buyer's signature \_\_\_\_\_

Warning to transferor and transferee (seller and buyer): You are required by law to state the true selling price. A false statement is in violation of section 2921.13 of the Ohio Revised Code and is punishable by six months imprisonment and a fine of up to one thousand dollars, or both. All transfers are audited by the Department of Taxation. The seller and buyer must provide any information requested by the Department of Taxation. The buyer may be assessed any additional tax found to be due.

**APPLICATION FOR CERTIFICATE OF TITLE (Type or Print in Ink)** Fee of \$5.00 for failure to apply for title within 30 days of assignment.

Check type of application(s):  Motor Vehicle  Memorandum  Watercraft  Outboard Motor  Salvage

Applicant's printed name \_\_\_\_\_ SSN/EIN \_\_\_\_\_

Applicant's printed address \_\_\_\_\_

Purchase Price \$ \_\_\_\_\_ Gross Tax Due \$ \_\_\_\_\_ Vendor's Discount \$ \_\_\_\_\_ Tax Paid \$ \_\_\_\_\_

Tax exemption:  Yes Reason \_\_\_\_\_ Dealer's Permit Number \_\_\_\_\_ Vendor's Number \_\_\_\_\_

Condition of vehicle or watercraft or outboard motor (check only one):  Good  Fair  Poor  Wrecked

**LIEN INFORMATION:** If no lien, state "none". If more than one lien, attach statement of all additional liens.

Lienholder \_\_\_\_\_ Address \_\_\_\_\_

I (we) state that all information contained in this application is true and correct. Is Applicant a Minor?  Yes  No

Applicant's signature \_\_\_\_\_

Sworn to and subscribed in my presence by \_\_\_\_\_ this \_\_\_\_\_ day of \_\_\_\_\_ yr.

My commission expires \_\_\_\_\_ yr.  
(seal) Clerk, Deputy Clerk of Courts - Notary \_\_\_\_\_

**STRAIGHT-PAYMENT-LEASE REPURCHASE WORKSHEET - BRC COMMON**

**File Number**  
[REDACTED]

**Customer Name**  
[REDACTED] r

**Worksheet Filled Out By:**

kate stertz

**Draft**-Add question marks beside category (not in dollar fields) to indicate incomplete information

**Vehicle VIN:**

1GNDT13S222 [REDACTED]

**Date:**

July 14, 2015

USAGE FORMULAS		STRAIGHT REPURCHASE - BASE		PAYMENT (CA, FL & WV) OR LEASE REPURCHASE				
1	<b>To calculate usage:</b>	1	Base Price	\$3,500.00	1	Down Pmt / Cap Cost Reduction	\$0.00	
2	Use ONLY one of the 4 methods in this column or follow applicable lemon law formula for your state	2	Conversion / Upfit cost	\$0.00	2	Pmts (includes 1st month if lease)	\$0.00	
3		3	Reg./Lic./Title Fees	\$0.00	3	Reg./Lic./Title Fees (leases only)	\$0.00	
4		4	State Fees	\$0.00	4	Tax (leases only)	\$0.00	
5		<b>A. USAGE USING L.L. FORMULA</b>	5	Aftermarket Items	\$0.00	5	Aftermarket Items	\$0.00
6	Base Price/Total Repurch Price	\$0.00	6	Sales Tax	\$0.00	6	Other-Explain	\$0.00
7	Mileage	0	7	Finance Charges	\$0.00	7	Other-Explain	\$0.00
8	Denominator	100,000	8	GMPP (* only for WI)	\$0.00	8	Other-Explain	\$0.00
9	<b>Usage</b>	<b>\$0.00</b>	9	Other-Explain	\$0.00	9	Other-Explain	\$0.00
10			10	<b>Total Purchase Price</b>	<b>\$3,500.00</b>	10	<b>Total Additions</b>	<b>\$0.00</b>
11	<b>B. USAGE - NEGOTIATED</b>	<b>\$0.00</b>	11			11		
12			12	<b>* Usage/Depreciation</b>	<b>\$0.00</b>	12	<b>* Usage/Depreciation</b>	<b>\$0.00</b>
13			13	Damage	\$0.00	13	Damage	\$0.00
14	<b>C. USAGE USING CENTS/MILE</b>		14	Late charges	\$0.00	14	Late charges	\$0.00
15	Mileage	0	15	Over-Allowance	\$0.00	15	Over-Allowance	\$0.00
16	Cents per mile	\$0.000	16	Negative Equity	\$0.00	16	Negative Equity	\$0.00
17	<b>Usage</b>	<b>\$0.00</b>	17	Incentives	\$0.00	17	Incentives	\$0.00
18			18	Other-Explain	\$0.00	18	Sec. Dep. (leases) if reimbursing above	\$0.00
19			19	Other-Explain	\$0.00	19	Extended Service Contract	\$0.00
20	<b>D. USAGE-CALIFORNIA ONLY</b>		20	Other-Explain	\$0.00	20	Gap Insurance	\$0.00
21	Base price section-Used when NOT financed.		21	Other-Explain	\$0.00	21	Over Mileage Penalty	\$0.00
22	<b>"Actual Price Paid" (Base)</b>	<b>\$3,500.00</b>	22	<b>Total Deductions</b>	<b>\$0.00</b>	22	<b>Total Deductions</b>	<b>\$0.00</b>
23	Mileage	0	23			23		
24	<b>Usage</b>	<b>\$0.00</b>	24	<b>Repurchase Subtotal</b>	<b>\$3,500.00</b>	24	<b>Total Refund to Customer</b>	<b>\$0.00</b>
25	<b>OR</b>		25	Loan Payoff good thru xx/xx/xx	\$0.00	25	Dlr Buyout (lease) or Loan Payoff	\$0.00
26	Payment/Lease-Used when financed.		26	<b>Total Refund to Customer</b>	<b>\$3,500.00</b>	26	(GMAC=DL quote) good thru xx/xx/xx	
27	<b>"Actual Price Paid" (Pmt/Lease)</b>	<b>\$0.00</b>	27	Attorney's Fees	\$0.00	27	Attorney's Fees	\$0.00
28	Mileage	0	28	<b>Total Repurchase</b>	<b>\$3,500.00</b>	28	<b>Total Repurchase</b>	<b>\$0.00</b>
29	Any ext service contract (CA only)	0	29	NADA (Legal Only)	\$0.00	29	NADA (Legal Only)	\$0.00
30	<b>Usage</b>	<b>\$0.00</b>	30	<b>Estimated Auction Value</b>	<b>\$0.00</b>	30	<b>Estimated Auction Value</b>	<b>\$0.00</b>
31			31	<b>Projected Loss</b>	<b>\$3,500.00</b>	31	<b>Projected Loss</b>	<b>\$0.00</b>
	PURCHASE PRICE (before t/t)	\$ 26,293.95		TRADE ALLOWANCE			PURCHASE PRICE	\$ -
	MSRP ( FROM BARS INVOICE)	\$ 29,870.00		PAYOFF OF TRADE	\$ -		INCENTIVE* (from BARS)	\$ -
	<b>DIFFERENCE</b>	<b>\$ (3,576.05)</b>		<b>DIFFERENCE</b>	<b>\$ -</b>		OVERALLOWANCE	\$ -
	if positive look for over allowance			if negative=negative equity			<b>ACTUAL PRICE</b>	<b>\$ -</b>
				<b>TRADE ALLOWANCE</b>	<b>\$ -</b>			
				ACV OF TRADE			Do not include fuel fill credit	
	Authorized Signature	Date		<b>DIFFERENCE</b>	<b>\$ -</b>		Include GM card points	
				ACV=actual cash value				

**Customer**

██████████  
 ██████████  
 Call Anytime

**Vehicle**

2007 GMC Envoy  
 1GKDT13S87██████████  
 Mileage now: 86000 mi

**Status of vehicle/concern**

A GM Dealer has NOT diagnosed current concern  
 Repairs have not been scheduled  
 Vehicle is currently operable & can be driven

**Key Points**

Customer stated, repeat repair concern with the headlamps, inoperable –do not come on, and it is a safety issues. Customer strongly stated, very frustrated and concern, recently received a ticket because of this same issue, and GM should be accountable for their products.

Customer expectations/ seeks; want GM assistance with the cost of repair and possible to get the TAC Support Team involved to inspect thoroughly to determine a definitive resolution.

CRS adv, the case will be sent over to the CEM/David Tausch, the CEM/is cust single point of contact, and the CEM will reach out to the cust w/in next 24 to 48 hour, to scheduled vehicle in for service, and discuss the Resolution with the customer.

Dorice Williams/CAC/WMI/T2

Supporting Factors	Limiting Factors
<p>First time GM buyer (verified)</p> <p>Vehicle has been serviced for this concern: 3 time(s)                      Vehicle was inop/down due to this concern: 7 day(s)                      Customer has incurred costs due to this concern</p>	<p>Vehicle is &gt; 8 years old (verified)</p>
<p><i>Please consider these additional questions:</i>                      Close to any applicable expiration limit? (wrnty, spl covg, svc contrt)                      Did cust buy an extd svc contract, but it's expired or n/a?                      Is this a loyal service customer? (to involved dealer)                      Are high dollar customer-pay ROs on record for this cust?                      Is this a conquest buyer?</p>	<p><i>Please consider these additional questions:</i>                      Is vehicle way beyond all applicable expiration limits?                      Does veh have an active <u>aftermarket</u> Extd Svc Contract?                      Did customer buy vehicle outside of warranty?                      Does it seem customer doesn't take care of the vehicle?                      Is cause not normally covered by warranty?                      Is cause due to an accident insurance won't cover?                      Is cause due to damage by independent repair facility?</p>

**Additional key points**

This customer has purchased these GM vehicles (verified): 1GKDT13S8721██████████  
 2007 GMC Envoy

**Reference**

CAC SR#: ██████████85  
 CAC advisor: Dorice Williams--> (866) 790-5700, Ext # 21774



ZIP CODE: 53214 | Sign in (or Sign up)

- Home
- Car Values
- Cars for Sale
- Car Reviews
- Awards & Top 10s
- Research Tools

Popular at KBB.com

[Compact SUV Buyer's Guide](#)

Advertisement

Why ads?

Home > Car Values > Chevrolet > TrailBlazer > 2003 > Style > Options > LS Sport Utility 4D

Chevrolet TrailBlazer 2003 Go

# Your Blue Book® Value

Show Used Car Prices | Price Your Next Car



## 2003 Chevrolet TrailBlazer

Style:

[Edit options](#) | [Check specs](#)

Mileage:

[Change](#)

Like

Trade In to a Dealer

Get an Instant Cash Offer

Sell to a Private Party



### CAR INSURANCE

Start at \$19 MONTH

Pr... report

The... tos,

spe... switch & Save on

ur Car Insurance

et a Free Quote

Today!

in... ar

Fin... buy

Advertisement

YOU... way:

[Get your offer](#)

Advertisement

Why ads?

Recently Viewed Cars | My Saved Cars [Save car](#)



### Good Condition

Trade-in Values valid for your area through 7/16/2015  
[Track this car's values](#)

### Tell Us About This Car

Owners like you rated the 2003 TrailBlazer 8.2 out of 10.

[Write your own review](#)

### Next Steps to Selling Your Car

#### Benchmark Local Prices

See what dealers and private sellers in your area are asking for your car.

[See listings](#)

#### Give Buyers Confidence

Show them a clean AutoCheck vehicle

[Go](#)

Advertisement

Why ads?

history report and close the deal fast.

### List It for Sale

Reach millions of in-market shoppers on KBB.com and AutoTrader.com.

Place your ad

## Free Dealer Price Quote

Get the best price and be more prepared with your free, no-obligation price quote

Chevrolet

Model

ZIP Code 53214

Get your quote

Advertisement



Why ads?

Advertisement

Why ads?

Search: Find car values or features

#### Popular Topics

- New Cars for 2014
- Used Cars
- Cars For Sale
- Car Buying Guides
- Car Awards

#### Car Reviews & News

- Car Reviews
- Car Videos
- Auto Shows
- Car News
- Best Cars

#### Help

- FAQ
- Site Map
- Find a New Car
- What's My Car Worth
- KBB® Mobile

#### Company

- About Us
- Contact Us
- Careers
- Corporate Information

#### Industry Relations

- Advertising
- Media Center
- Linking Policy
- Business Solutions

Follow KBB

Facebook

Twitter

Google+

YouTube

LinkedIn

RSS

Mobile Apps

iPhone

Android

© 1995-2015 Kelley Blue Book Co., Inc. All rights reserved. Copyright & Trademarks | Terms of Service | Privacy Policy | Ad Choices

Have comments about our Blue Book Values? Give us your feedback.

© 2015 Kelley Blue Book Co., Inc. All rights reserved. 7/10/2015-7/16/2015 Edition for Wisconsin 53214. The specific information required to determine the value for this particular vehicle was supplied by the person generating this report. Vehicle valuations are opinions and may vary from vehicle to vehicle. Actual valuations will vary based upon market conditions, specifications, vehicle condition or other particular circumstances pertinent to this particular vehicle or the transaction or the parties to the transaction. This report is intended for the individual use of the person generating this report only and shall not be sold or transmitted to another party. Kelley Blue Book assumes no responsibility for errors or omissions. (v.15072)

Templa

Type of case	
Status	IE. O
SR Number	
Customer Name (Last name/First Name)	
Year/Make/Model	
VIN	
Incident Date	
Purchase Date	Date vehic
Titled in who's name	
Purchase Price	
Open/Closed Recalls (If closed include closed Transaction History)	Product S Noncomplia - 09/09/2003 AND TORQU
Mileage	
Purchased From	Private part
Vehicle Insured	
MSRP/KBB (Trade-in Good Value)	
Loaner Vehicle (yes/no from drop down and enter date issued)	Yes/No
Information included in this:	
PARTS RETURN INFO	

Verify before sending E-mail:

**IS THE FORM COMPLETE WITH ALL INFORMATION?**

**Have Photos been attached in Seibel**

please review to ensure photos are clear and show c  
Must include at least one close up showing damage/

**One Call Handling: Please include in body of email v**

If necessary include copy of any additional fire/polic

If you are handling a case that requires **ESISQFYI act**

All fire cases with ESISQFYI requires email notificatio

te Instructions

Fire , Smoke , Melt	Case Summary
Open/Closed/Photos/Inspection/Escalate to ESIS/UTC	IE;
SR#*****	Customer allegation:
Doe, John	Photos in SIEBEL
2014 Chevrolet Cruze	Ordered Raytheon 11/11/2014
1ABC234DEF [REDACTED]	Ordered Dealer Inspection/diagnosis & Repair Estimate
Date that the incident occurred	Inspection Complete 11/21/2014 document in SIEBEL
Vehicle was purchased (If unknown, customers best judgement)	Case closed pending customer action
John Doe/Husband	Case closed UTC
\$10,000/Unknown/Estimate is fine.	
Safety Recall N140350 14350 UNINTENDED IGNITION KEY ROTATION 08/30/2014 Open	
Service Recall N030045 03045 RIGHT REAR BRAKE HOSE FITTING 08/28/2003 Closed	
3 067852 ZFAT----Field Action Recall V1056 - 03045 - INSPECT REAR RIGHT REAR BRAKE HOSE 1,841 MI (information available in Transaction History)	
10,000	
Location: Used Car Lot or GM Dealership. (specific names required)	
Yes or No	
\$7,800.00	
Date issued	

Additional Information as requested by TC/TL

This box is for information requested as the case progresses. With examples such as below

ADDITIONAL INFORMATION, EG: Job Card Number: 63172,BAC: 114850, Labor Op Code: 0600006

Or

Customer 360 information ETC.

Damage

Fire, Overall of damaged area, Broad view to show the environment surrounding the area and a photo of all four  
**why case is being closed on the first "new email".**  
e reports, dealer inspections, and copy of title and registration as necessary.

**ivity** please confirm that this activity has been completed in Siebel prior to sending the Fire Case Initial Email to the  
TC and TCL regardless if case remains open or closed on first contact.

To: Mickey.sabol@gm.com

Cc: Kimberly.horvath@gm.com

This button will copy the to, cc,  
subject

Subject: IE. Open/Closed/Photos/Inspection/Escalate to ESIS/UTC - Fire , Smoke , Melt SR# SR#\*\*\*\*\*

These buttons will copy and reset the  
template

**PASTE TEMPLATE IN EMAIL USING CTRL+V**

IT'S VERY IMPORTANT TO  
FOLLOW THIS STEP!

sides of vehicle exterior.

ne Fire Team.

, and

Fire Case

Smoke Case

Melt Case

New

Reopen

Photos

Update

Inspection received

Question

Closed

*Estimate is OK*

Yes

No



d

### Fire Case template

Type of case	Fire Case	
Status	Closed	
SR Number	[REDACTED]	
Customer Name (Last name/First Name)	[REDACTED]	
Year/Make/Model	2003 Chevrolet Trailblazer	
VIN	1GNDDT13S3323 [REDACTED]	
Incident Date	7/7/2015	
Purchase Date	1/1/2014	
Titled in who's name	Andrew Sonnenburg(lien on title)	
Purchase Price	\$7,500.00	
Open/Closed Recalls (If closed include closed Transaction History)	<p style="text-align: center;"><i>Product Safety Recall N040087 04087 TAIL LAMPS/STOP LAMPS 11/16/2004 Closed 06/20/2005 363042 ZFAT----Field Action Recall V1265 - 04087 - Inspect and Replace One or Both Tail Lamp Circuit Boards and Lamps 1 MI</i></p>	
Mileage	107,000	
Purchased From	used car dealer	
Vehicle Insured	Yes	
MSRP/KBB (Trade-in Good Value)	KBB \$2888	
Loaner Vehicle (yes/no from drop down and enter date issued)	No	
Additional Information as requested by TC/TL		

Verify before sending E-mail:

**IS THE FORM COMPLETE WITH ALL INFORMATION?**

**Have Photos been attached in Seibel**

please review to ensure photos are clear and show damage

Must include at least one close up showing damage/fire, Overall of damaged area, Broad view to show the envi  
**One Call Handling: Please include in body of email why case is being closed on the first "new email".**  
If necessary include copy of any additional fire/police reports, dealer inspections, and copy of title and registrati

If you are handling a case that requires **ESISQFYI activity** please confirm that this activity has been completed in  
All fire cases with ESISQFYI requires email notification to the TC and TCL regardless if case remains open or close

### Case Summary

Allegation; Customer states-says on 7/7 he was driving to work and his vehicle stalled out, he restarted it but when he made it to work he smelled burning plastic, he opened the hood and found a small flame near the fusebox, he disconnected the battery and the fire smoldered out, he has full insurance coverage so he made a claim and is supposed to hear from them today-they did ask him to call GM, the vehicle is at the dealership and he was given a repair estimate of \$2400 and he has authorized repairs, purchased vehicle from a used car dealer a year and a half ago for \$7500 and still has a lien on it for \$3000, says needs car so authorized the repairs and he hopes insurance will cover it

Environment surrounding the area and a photo of all fo

ion as necessary.

1 Siebel prior to sending the Fire Case Initial Email to  
ed on first contact.

To: Mickey.sabol@gm.com

Cc: Kimberly.horvath@gm.com

Subject: Closed - Fire Case SR# [REDACTED]

**PASTE TEMPLATE IN EMAIL USING CTRL+V**

ur sides of vehicle exterior.

the Fire Team.

Fire Case

Smoke Case

Melt Case

New

Reopen

Photos

Update

Inspection received

Question

Closed

*Estimate is*

Yes

*No*

# CAC SR Data Share

**Save XLSM to Desktop**

**Save PDF to Desktop**

**Clear Form**

## After completing the SRDS, do this:

- 1) Grey 'Spellcheck' button to check spelling (at the bottom)
- 2) Blue 'Save XLSM to Desktop' button
- 3) Green 'Save PDF to Desktop' button & CLOSE the PDF file (red x)
- 4) Copy 'Key Points' (pink cell) to new "SR Summary" Comments
- 5) Attach the Excel (.xlsm) file to the SR
- 6) Attach the PDF file (.pdf) to the A02 SRDS email to the CEMs
- 7) Red 'Clear Form' button
- 8) Complete a new SRDS. Be sure save using the buttons!!

Customer's name (for your reference):

Samantha Bryant

Key Points:

STS: door switch has gone bad and heated seats go on then the windows go up (not down) and the headlights flicker on and off. this started one week ago, suddenly

**What is the customer's concern?**

**What help is the customer seeking?**

**What expectations did you set for the customer?**

If I hit button to send window down, does not work, until I turn the heated seats off. Dealer stated that it is an internal switch. estimate 575.37.

You are empowered to deliver **Exceptional Customer Experiences!**

SKS: cost assistance

ADV: I explained that I am going to forward this information to the dealer, but due to mileage/years/bought used cannot promise assistance.

Eric Nustad\CAC\T2\WMI

Customer's preferred phone #:

(904) 294-9978

Best time to call customer:

any

Has the customer had the current concern diagnosed by a GM Dealer?	A GM Dealer has diagnosed the current concern
What is the status of the repairs (to address the current concern)?	Repairs have not been scheduled
How many times has vehicle been serviced for this same concern (at any svc location)?	1
How many <u>days</u> has vehicle been inoperable (down) because of this concern?	0
Current status of the vehicle (operable or inoperable)?	Vehicle is currently operable & can be driven
Has customer spent money out-of-pocket as a result of this concern?	No
Current mileage (in <u>miles</u> )?	191,454
Bought brand new?	No
<i>(if bought used)</i> Roughly how many <u>miles</u> were on the vehicle at time of purchase?	134,000
<i>(if bought used)</i> Was vehicle bought (used) at a GM Dealership?	No
Did customer purchase an Extended Service Contract (GM, Divisional, Aftermarket)?	

**End conversation with the customer here.** Complete the rest of the SR Data Share in ACW (After Call Work).

Today's date:	7/16/2015
SR#:	██████████
CAC advisor's name (first & last):	Eric Nustad
CAC advisor's phone #:	(866) 790-5700
CAC advisor's extension #:	21792
17-digit VIN#:	1GNDT13S352 ██████████
Make:	Chevrolet
Model:	TrailBlazer
Model Year:	2005
Is this a high-dollar or premium vehicle?	Yes
Does this VIN have any <u>active</u> Extended Service Contracts?	No
Does Order Type contain the word "FLEET"?	No
Branded Title?	No
Warranty Block?	No
Warranty Start Date for this VIN:	6/16/2005

*(if bought used)* Is this a GM Certified pre-owned used vehicle?

--

Is this the original owner?

No
----

List of GM vehicles owned by this customer:  
*(including the vehicle they're calling about now)*

2005 Chevrolet Trailblazer
----------------------------

Total number of GM vehicles this customer has owned:  
*(including the vehicle they're calling about now)*

1
---

**Customer**

[REDACTED]

Call any

**Vehicle**

2005 Chevrolet TrailBlazer

1GNDT13S3522 [REDACTED]

Mileage now: 191454 mi

**Status of vehicle/concern**

A GM Dealer has diagnosed the current concern

Repairs have not been scheduled

Vehicle is currently operable & can be driven

**Key Points**

STS: door switch has gone bad and heated seats go on then the windows go up (not down) and the headlights flicker on and off. this started one week ago, suddenly

If I hit button to send window down, does not work, until I turn the heated seates off. Dealer stated that it is an internal switch. estimate 575.37.

SKS: cost assitance

ADV: I explained that I am going to forward this information to the dealer, but due to mileage/years/bought used cannot promise assistance.

Eric Nustad\CAC\T2\WMI

Supporting Factors	Limiting Factors
<p>First time GM buyer (verified)</p> <p>High-dollar or premium vehicle</p> <p>Vehicle has been serviced for this concern: 1 time(s)</p>	<p>Vehicle is &gt; 8 years old (verified)</p> <p>Vehicle has &gt; 100,000 miles</p>
<p><u>Please consider these additional questions:</u></p> <p>Close to any applicable expiration limit? (wrnty, spl covg, svc contrt)</p> <p>Did cust buy an extd svc contract, but it's expired or n/a?</p> <p>Is this a loyal service customer? (to involved dealer)</p> <p>Are high dollar customer-pay ROs on record for this cust?</p> <p>Is this a conquest buyer?</p>	<p><u>Please consider these additional questions:</u></p> <p>Is vehicle way beyond all applicable expiration limits?</p> <p>Does veh have an active <u>aftermarket</u> Extd Svc Contract?</p> <p>Did customer buy vehicle outside of warranty?</p> <p>Does it seem customer doesn't take care of the vehicle?</p> <p>Is cause not normally covered by warranty?</p> <p>Is cause due to an accident insurance won't cover?</p> <p>Is cause due to damage by independent repair facility?</p>

**Additional key points**

Approximate # of miles on the vehicle when customer purchased it (used): 134000 mi

This customer has purchased these GM vehicles (verified): 2005 Chevrolet Trailblazer

**Reference**

CAC SR#: [REDACTED]

CAC advisor: Eric Nustad--> (866) 790-5700, Ext # 21792

## **General Excel Tips:**

Right click on any cell with a comment & choose "Show/Hide Comments" to make the Comment stick (stay visible)  
When you're done, Right click the cell with the comment showing & choose "Show/Hide Comments" to make the

Ctrl+C to copy; Ctrl+V to paste; Ctrl+X to cut

If you leave & come back, click inside the cell & pick up at the blinking cursor (to prevent typing on top of what was

Alt+Enter lets you return to the next line inside a cell

Alt + down arrow key will show you the dropdown menu/choices list (do this if you don't like using a mouse)

even when you click away from that cell).  
Comment go away (become hidden from immediate view).

is already there)



Hummer

Yes - This V

Unresolved - Customer No - This is

Diagnosed

No

IN has received goodwill or cost assistance

a new SR



December 13, 2017

[REDACTED]  
[REDACTED]  
Brainerd, MN [REDACTED]

Dear [REDACTED]

At Chevrolet, we take pride in the vehicles we produce and appreciate the time you took to contact us.

Because customer satisfaction is a top priority for us, please accept this letter worth up to \$100 towards your next maintenance service or repair on your 2007 Chevrolet TrailBlazer.

This offer is valid towards one service visit on VIN 1GNET13M372[REDACTED]8. In the event the cost of your service exceeds the \$100 maximum value, you will be responsible for paying the difference. If the total cost of your services is less than \$100, a credit or refund will not be issued. This letter is not transferable and is valid for 12 months from the date of issue.

We hope this gesture demonstrates our appreciation of you as a valued customer. Simply present this letter to any Chevrolet dealership for redemption. If you have future questions, please don't hesitate to email us using the Contact Us link at Chevrolet.com or call us at 1-800-222-1020.

Sincerely,

Chevrolet Customer Assistance Center  
Service Request [REDACTED]

For more information regarding the maintenance and care of your vehicle, please visit [www.gm.com/vehicles/owner\\_advantages.html](http://www.gm.com/vehicles/owner_advantages.html). This free online service offers vehicle and ownership-related information and tools tailored to your specific vehicle.

---

ATTENTION: DEALERSHIP SERVICE MANAGER

When submitting the claim, please use labor op 0600046. Insert the amount in the net item column and insert the CAC Service Request number in your comments. This original letter must be surrendered by the customer and retained by the dealer for audit purposes.

Type of case	Melt Case	Case Summary
Status	Closed	<p>Allegation; Customer alleges melting was a defect because the fuse did not trip to protect from an overload. Customer seeks to report the issue, and a vehicle repair. Customer also seeks a rental.</p> <p>After discussion, the customer decided not to pursue a PAC claim. The vehicle has been taken to an independent for a repair.</p> <p>Closing file, customer satisfied.</p>
SR Number	[REDACTED]	
Customer Name (Last name/First Name)	[REDACTED]	
Year/Make/Model	2003, Chevrolet, Trailblazer	
VIN	1GNDS13S432 [REDACTED]	
Incident Date	7/22/2015	
Purchase Date	11/29/2002	
Titled in who's name	customer's	
Purchase Price	unknown	
Open/Closed Recalls (If closed include closed Transaction History)	<p><i>Recalls: Product Safety Recall N040087 04087 TAIL LAMPS/STOP LAMPS 11/16/2004 Closed, 10/20/2005 - Inspect and Replace One or Both Tail Lamp Circuit Boards and Lamps 42,335 MI</i></p> <p><i>Special Coverages: 04017- Tail Lamps/Stop Lamps</i></p>	
Mileage	189,643	
Purchased From	dealership	
Vehicle Insured	Yes	
MSRP/KBB (Trade-in Good Value)	\$1,206.00	

Loaner Vehicle (yes/no from drop down and enter date issued)	No		
--	----	--	--

Additional Information as requested by TC/TL

--



ZIP CODE: 34945 | Sign In (or Sign up)

- Home
- Car Values
- Cars for Sale
- Car Reviews
- Awards & Top 10s
- Research Tools

Popular at KBB.com

10 Coolest Cars Under \$18,000

Advertisement

Why ads?

Home > Car Values > Chevrolet > TrailBlazer > 2003 > Style > Options > LS Sport Utility 4D

Chevrolet TrailBlazer 2003 Go

# Your Blue Book® Value | Find Your Next Car

Show Used Car Prices Print report



## 2003 Chevrolet TrailBlazer

Style: LS Sport Utility 4D

Mileage: 189643 [Change](#)

[Edit options](#) | [Check specs](#)

- Trade In to a Dealer
- Get an Instant Cash Offer
- Sell to a Private Party



### Next Step: Find a Car

Browse reviews, photos, specs and more.

[See what you should pay](#)

### Instant Cash Offer

Find dealers ready to buy your car - today!

[Get your offer](#)

Advertisement

Why ads?

**CAR INSURANCE - \$19 MONTH**  
Switch & Save on Your Car Insurance Get a Free Quote Today!

Recently Viewed Cars | My Saved Cars [Save car](#)



Good Condition

Trade-in Values valid for your area through 7/30/2015  
[Track this car's values](#)

### Tell Us About This Car

Owners like you rated the 2003 TrailBlazer 8.2 out of 10.

[Write your own review](#)

### Next Steps to Selling Your Car

#### Benchmark Local Prices

See what dealers and private sellers in your area are asking for your car.

[See listings](#)

#### Give Buyers Confidence

Show them a clean AutoCheck vehicle history report and close the deal fast.

Enter VIN (optional) [Go](#)

#### List It for Sale

Reach millions of in-market shoppers on KBB.com and AutoTrader.com.

[Place your ad](#)

Advertisement

Why ads?

Advertisement

Why ads?

### Free Dealer Price Quote

Get the best price and be more prepared with your free, no-obligation price quote

Advertisement

Why ads?

Search:

Popular Topics

- New Cars for 2016
- Used Cars
- Cars For Sale
- Car Buying Guide
- Car Awards

Car Reviews & News

- Car Reviews
- Car News
- Auto Shows
- Car News
- Best Cars

Help

- FAQ
- Site Map
- Try a New Car
- What's My Car Worth?
- KBB Mobile

Company

- About Us
- Contact Us
- Careers
- Company Information

Industry Solutions

- Advertising
- Media Center
- Business Solutions

- Follow KBB
- Facebook
- Twitter
- Google+
- YouTube
- LinkedIn
- RSS
- Mobile Apps
- iPhone
- Android

© 1995-2015 Kelley Blue Book Co., Inc. All rights reserved. Copyright & Trademarks | Terms of Service | Privacy Policy | Ad Choices

Have comments about our Blue Book Values? Give us your feedback.

© 2015 Kelley Blue Book Co., Inc. All rights reserved. 7/24/2015-7/30/2015 Edition for Florida 34945. The specific information required to determine the value for this particular vehicle was supplied by the person generating this report. Vehicle valuations are opinions and may vary from vehicle to vehicle. Actual valuations will vary based upon market conditions, specifications, vehicle condition or other particular circumstances pertinent to this particular vehicle or the transaction or the parties to the transaction. This report is intended for the individual use of the person generating this report only and shall not be sold or transmitted to another party. Kelley Blue Book assumes no responsibility for errors or omissions. (v.15074)

IMG\_7169.JPG



**Customer**

[REDACTED]  
[REDACTED]

**Vehicle**

2006 Chevrolet TrailBlazer  
1GNES16S06 [REDACTED]  
Mileage now: 177000 mi

**Status of vehicle/concern**

A GM Dealer has NOT diagnosed current concern  
Repairs have not been scheduled  
Vehicle is currently operable & can be driven

**Key Points**

Cust sts that his vehicles headlamps will go out intermittently while driving down the road at night. Cust has been to the dlr twice and the dealer has not been able to duplicate the issue.

Cust sts that he has paid the diagnosis twice and has not had any results. Cust sts that he does not want to keep on paying the diagnosis and keep getting the same answer.

Cust sts that this issue is dangerous and GM is not doing anything about it. Cust would like to get assistance to repair the vehicle.

Cust sks vehicle repair

SA Adv will reach out to the CE Manager to come to a resolution.

Supporting Factors	Limiting Factors
<p>Customer has incurred costs due to this concern</p>	<p>Vehicle is &gt; 8 years old (verified) Vehicle has &gt; 100,000 miles</p>
<p><i>Please consider these additional questions:</i>                      Close to any applicable expiration limit? (wrnty, spl covg, svc contrt)                      Did cust buy an extd svc contract, but it's expired or n/a?                      Is this a loyal service customer? (to involved dealer)                      Are high dollar customer-pay ROs on record for this cust?                      Is this a conquest buyer?</p>	<p><i>Please consider these additional questions:</i>                      Is vehicle way beyond all applicable expiration limits?                      Does veh have an active <u>aftermarket</u> Extd Svc Contract?                      Did customer buy vehicle outside of warranty?                      Does it seem customer doesn't take care of the vehicle?                      Is cause not normally covered by warranty?                      Is cause due to an accident insurance won't cover?                      Is cause due to damage by independent repair facility?</p>

**Additional key points**

**Reference**

CAC SR#: [REDACTED]  
[REDACTED]-5700, Ext # 5921543

From: [REDACTED]  
Sent: Friday, July 31, 2015 6:38 PM  
To: Mary T. Barra; dan.ammann@gm.com; Alan Batey; Alicia S Boler Davis  
Subject: What is a Customer's Life Worth?

Good evening.

I, a General Motors customer, am writing to you today to ask, "What is a customer's life worth at General Motors?".

I thought GM prided itself in providing quality vehicles, safe vehicles and outstanding service to its customers. However, after my recent experience, I now know that none of these are true.

Does GM care that it is endangering the lives of its customers by excluding certain VIN numbers from a safety recall? Is GM more concerned about saving a buck than helping its customers? My answer to both of these is a resounding yes.

I am writing to all of you, in a last ditch effort, to prove that you care about me and my family. I want to see that you care about our safety and whether or not our lives are worth the few dollars you need to spend to resolve this issue.

Please do the right thing and READ THIS LETTER. Please do the right thing and TAKE ACTION on this letter.

I own a 2007 Chevy Trailblazer, VIN 1GNDS13S972 [REDACTED], with approximately 86,000 miles on it. On 7/28/15, while we were driving home AT NIGHT AND IN COMPLETE DARKNESS, both headlamps simultaneously failed. All of the fuses are good. Both headlamps were tested by my husband and found to be good. We almost wrecked the vehicle and our entire family was in the car.

Thankfully, we were able to use the high beam headlamps to drive the rest of the way home. After returning home, we parked the vehicle for a few hours. We checked the headlamps and they still did not work while on low beam setting. They failed again on 7/29, 7/30, and again today.

After researching the issue on NHTSA'S website, because this is a SAFETY issue, I discovered that a recall exists for this same year, make and model. I also found MANY blogs online that indicate that this issue is on-going and has been a known issue with Trailblazers since before 2003. I also learned that MANY OTHER CUSTOMERS have made the same complaint on NHTSA and have been told, "sorry, your VIN isn't included in the recall".

So, what does it take for GM to do the right thing and GET THESE VEHICLES INCLUDED in this recall? Do you have to wait for a member of my family to be killed in a crash before you step up and do the right thing?

I have asked that GM do a formal diagnostic on my vehicle, at GM's cost, and to properly repair this vehicle.

Your Customer Care refuses. Your dealership refuses. Your managers at customer care refuse.

I guess our family is not worth the minute amount required for a diagnostic assessment (under \$100). I guess we're not worth the \$40 or so it takes to replace the HDM on this vehicle. I guess we are not worth anything.

I am so disgusted with the lack of commitment in this, to the point that I don't know whether or not I will ever buy another GM vehicle (and I've owned a Chevy since I was 16 years old--more than 24 years).

What are you going to do to help me?

Regards,

[REDACTED]

[REDACTED] >

Phone [REDACTED] (mobile)

Nothing in this message is intended to constitute an electronic signature unless a specific statement to the contrary is included in this message.

Confidentiality Note: This message is intended only for the person or entity to which it is addressed. It may contain confidential and/or privileged material. Any review, transmission, dissemination or other use, or taking of any action in reliance upon this message by persons or entities other than the intended recipient is prohibited and may be unlawful. If you received this message in error, please contact the sender and delete it from your computer.

# CAC SR Data Share

**Save XLSM to Desktop**

**Save PDF to Desktop**

**Clear Form**

## After completing the SRDS, do this:

- 1) Grey 'Spellcheck' button to check spelling (at the bottom)
- 2) Blue 'Save XLSM to Desktop' button
- 3) Green 'Save PDF to Desktop' button & CLOSE the PDF file (red x)
- 4) Copy 'Key Points' (pink cell) to new "SR Summary" Comments
- 5) Attach the Excel (.xslm) file to the SR
- 6) Attach the PDF file (.pdf) to the A02 SRDS email to the CEMs
- 7) Red 'Clear Form' button
- 8) Complete a new SRDS. Be sure save using the buttons!!

Customer's name (for your reference):

[Redacted]

Key Points:

**What is the customer's concern?**  
**What help is the customer seeking?**  
**What expectations did you set for the customer?**

[Large yellow text area for key points]

You are empowered to deliver **Exceptional Customer Experiences!**

Customer's preferred phone #:

[Redacted]

Best time to call customer:

anytime

Has the customer had the current concern diagnosed by a GM Dealer?	A GM Dealer has diagnosed the current concern
What is the status of the repairs (to address the current concern)?	Repairs have not been scheduled
How many times has vehicle been serviced for this same concern (at any svc location)?	1
How many <u>days</u> has vehicle been inoperable (down) because of this concern?	
Current status of the vehicle (operable or inoperable)?	Vehicle is currently operable & can be driven
Has customer spent money out-of-pocket as a result of this concern?	Unsure/Unknown
Current mileage (in <u>miles</u> )?	170,000
Bought brand new?	No
<i>(if bought used)</i> Roughly how many <u>miles</u> were on the vehicle at time of purchase?	
<i>(if bought used)</i> Was vehicle bought (used) at a GM Dealership?	
Did customer purchase an Extended Service Contract (GM, Divisional, Aftermarket)?	Unsure/Unknown

**End conversation with the customer here.** Complete the rest of the SR Data Share in ACW (After Call Work).

Today's date:	8/5/2015
SR#:	██████████
CAC advisor's name (first & last):	Christina Reyna
CAC advisor's phone #:	(866) 790-5600
CAC advisor's extension #:	31078
17-digit VIN#:	1GNDS13S332 ██████████
Make:	Chevrolet
Model:	Blazer
Model Year:	2003
Is this a high-dollar or premium vehicle?	No
Does this VIN have any <u>active</u> Extended Service Contracts?	No
Does Order Type contain the word "FLEET"?	No
Branded Title?	No
Warranty Block?	No
Warranty Start Date for this VIN:	6/30/2003

*(if bought used)* Is this a GM Certified pre-owned used vehicle?

--

Is this the original owner?

No
----

List of GM vehicles owned by this customer:  
*(including the vehicle they're calling about now)*

2003 CHEVROLET TRAILBLAZER BUSR
---------------------------------

Total number of GM vehicles this customer has owned:  
*(including the vehicle they're calling about now)*

1
---

**Customer**

cell  
Call anytime

**Vehicle**

2003 Chevrolet Blazer  
1GNDS13S332  
Mileage now: 170000 mi

**Status of vehicle/concern**

A GM Dealer has diagnosed the current concern  
Repairs have not been scheduled  
Vehicle is currently operable & can be driven

**Key Points**

Supporting Factors	Limiting Factors
<p><u>Please consider these additional questions:</u>                      Close to any applicable expiration limit? (wrnty, spl covg, svc contrt)                      Did cust buy an extd svc contract, but it's expired or n/a?                      Is this a loyal service customer? (to involved dealer)                      Are high dollar customer-pay ROs on record for this cust?                      Is this a conquest buyer?</p>	<p><u>Please consider these additional questions:</u>                      Is vehicle way beyond all applicable expiration limits?                      Does veh have an active <u>aftermarket</u> Extd Svc Contract?                      Did customer buy vehicle outside of warranty?                      Does it seem customer doesn't take care of the vehicle?                      Is cause not normally covered by warranty?                      Is cause due to an accident insurance won't cover?                      Is cause due to damage by independent repair facility?</p>

**Additional key points**

**Reference**

CAC SR#:  
Tier 2 CAC advisor:

## **General Excel Tips:**

Right click on any cell with a comment & choose "Show/Hide Comments" to make the Comment stick (stay visible)  
When you're done, Right click the cell with the comment showing & choose "Show/Hide Comments" to make the

Ctrl+C to copy; Ctrl+V to paste; Ctrl+X to cut

If you leave & come back, click inside the cell & pick up at the blinking cursor (to prevent typing on top of what was

Alt+Enter lets you return to the next line inside a cell

Alt + down arrow key will show you the dropdown menu/choices list (do this if you don't like using a mouse)

even when you click away from that cell).  
Comment go away (become hidden from immediate view).

is already there)



Hummer

Yes - This V

Unresolved - Customer No - This is

Diagnosed

No

IN has received goodwill or cost assistance

a new SR





## Attention Service Manager / Director:

General Motors has been working to improve the customer experience and case evaluation. Please keep in mind that we will work together to ensure GM customer loyalty, goodwill, retention and positive Dealership relations. By doing this, we can demonstrate the importance of our customers to GM and instill confidence in our GM products. Providing a timely fair and accurate evaluation of their claim is important to customer Satisfaction and Loyalty. As a result of this customer centric focus, we have revised the Dealer Inspection Process to facilitate these improvements.

## **YOU will be paid fully for your efforts and time in support of this Process:**

General Motors understands that each inspection is unique, and the time to complete the inspection, and this report, will vary case-by-case. GM will make sure that you are appropriately compensated for the time to complete this inspection, and accurately document your findings.

**IT IS IMPORTANT THAT YOU READ AND UNDERSTAND THE DIRECTIONS BELOW BEFORE BEGINNING THE CASE INSPECTION PROCESS.** The information gathered during the investigation is proprietary to GM and should not be provided to the customer.

Your support is critical to a fair evaluation of this case and we must have all questions and requirements answered fully. The PAC advisor will **NOT** be able to provide compensation or authorization until a thorough inspection, diagnosis and repair estimate. This must include the details for all diagnostic testing with test detailed test results as recommended by GM Service Information, Repair Manuals and other Technical resources. Timely receipt of this information is critical to expedite case resolution. (Would like a time line for completion communicated to your assigned PAC Advisor within 24hr if possible).

There may be other GM resources / people involved in the evaluation process for each PAC (Product Assistance Claims) Case. It may be necessary to compare statements, information or images from these other sources to ensure accuracy between the Allegation and actual incident descriptions. Therefore we rely on these inspection forms to be stand-alone documents. Information gathered while assisting a 3<sup>rd</sup> party inspector, Field Service Engineer, or other technical resources / investigators should not be relied upon for completing this inspection form.

GM will provide assistance as necessary to support you in vehicle diagnosis and completion of this Inspection form. Please contact the PAC advisor assigned to this case when assistance is needed.

These forms should not be used for any cases involving injury (which required professional medical attention), or property damage outside of the vehicle. Refer to the information provided in the current Service Policies and Procedures Manual.

**Please proceed by completing the attached documentation using the following guidelines:**

- Utilize the same job card/repair order that was created when the customer brought their vehicle in for this concern. If one was never created, please create one once the vehicle is at your dealership.
- The assigned Product Assistance Claims (PAC) Specialist will provide you (Service Manager/Director) with a Pre-Authorization ID number after the completed inspection reports and photos are received.
- It is important to properly document this information as part of the case history. The PAC advisor is required to obtain detailed inspection reports, diagnosis and repair estimates.
- Reports should include information such as the inspection process, diagnostic testing performed and what lead to diagnosis, part numbers, part and labor descriptions etc. All costs should be itemized at the dealership's current warranty rates. Please take photos of the concern, the areas surrounding the concern, an overall photo of all four sides of the vehicle exterior and document any other pertinent information which may be relevant to the customers claim. Please verify the photos are in focus, bright and clearly show the areas of concern, then, return the forms and photos via email. Please provide a photo log which indicates the photo ID # and a description of the photos being submitted with the report.

### Preliminary Inspection Form for Dealers

#### Complete Vehicle Inspection Report (TO BE COMPLETED BY DEALER SERVICE MANAGEMENT)

Customer's First & Last Name:	██████████	Customer Phone:	██████████
Year/Make:	2007/Chevrolet	Case Number:	██████████
VIN:	1GNDT13S472██████████	Inspected by:	
Model:	Trailblazer	Inspector's phone	
Mileage:		Dealer City/ST	Philipsburg, PA
Dlr. BAC	281058	Warranty Rate:	

Provide driver/claimant's complete description of incident including the location, date and time of incident. Ask the Customer to provide this written statement of the incident details if possible. Identify if information was provided by driver and/or claimant. This is a very important section of the report:



--

**3. DIAGNOSTIC TROUBLE CODES:**

**CONTROL MODULE COMMUNICATION and DTC CHECK:** Using a scan tool. Record any control module that is not communicating, any DTC including symptom byte, module set and enter “C” for current or “H” for history code. (Include a copy of the Freeze Frame Failure Records if applicable)

List all Modules not Communicating	DTC / Symptom H / C & Module	DTC / Symptom H / Current & Module

**4. Additional Information:**

Describe the overall vehicle condition; list any previous repairs which may be pertinent to the case. Include any undercarriage damage possibly related to the allegation or not related. Please note if due to prior incident or current allegation.







Body damage estimates should be independent of mechanical repair estimates. All body estimates should be performed at GM Flat Rate Manual and approved warranty rates NOT Insurance rates.

## PHOTO LOG AND PHOTOS

PHOTO #	DESCRIPTION ONLY	DAMAGE YES/NO
1	Driver (Left) side Exterior ( <b>required image</b> )	
2	Passenger (Right) Side Exterior ( <b>required image</b> )	
3	Front Exterior ( <b>required image</b> )	
4	Rear Exterior ( <b>required image</b> )	
5	Image of concern & affected area ( <b>required image</b> )	
6	Close-up image of concern ( <b>required image</b> )	
7	Vehicle Certification Label with VIN visible ( <b>required image</b> )	
8	Add additional photos as necessary.	

**Attach Photos to an email or add to this document below.**

Product Assistance Center  
Preliminary Technical Consultant Report

Date: 8/27/2015

VIN: 1GNDDT13S472 [REDACTED]

SR #: [REDACTED]

Customer Name: [REDACTED]

Case Matter #: [REDACTED]

PAC Advisor: Stephanie Washington

Report/Recommendation:

Based upon available information, the customer's statements, and photos, it appears that the origin of the fire is consistent with field action 14291. 14291 is not associated with this vehicle. The customer stated the incident occurred on 8/10/2015 and the vehicle mileage is stated as 121,000.

Based on the available information, it is recommended that the vehicle be repurchased or repaired as appropriate. All charges for the repair or repurchase are to be made against the Labor Code for Field Action 14291.

If any additional information becomes available, this report may be revised.

Mickey Sabol

PAC Technical Consultant

Stephanie Washington (C)

---

From: Stephanie Washington (C)  
Sent: Wednesday, August 26, 2015 3:32 PM  
To: 'ashimmel@blaisealexander.com'  
Subject: SR# [REDACTED]  
Attachments: [REDACTED] 7 Dealer Inspection Template.docx; SAMPLE Dealer Inspection v3.docx

Anthony,

I have attached the dealer inspection form as well as a sample as it has changed, we will pay you up to 2 hours your hourly warranty labor rate for your assistance. We are in need of a dealer inspection, diagnosis, and repair estimate. If you have any questions please contact me.

Customer Last [REDACTED]  
2007, Chevrolet, Trailblazer  
VIN: 1GNDDT13S472 [REDACTED]  
Blaise Alexander Chevrolet Buick Of Philipsburg, Philipsburg, PA (281058)  
Anthony Shimmel, Service Manager

Thanks,

**Stephanie D. Washington**  
*General Motors Business Resource Center  
Product Assistance Claims Department*  
[stephanie.l.washington@gm.com](mailto:stephanie.l.washington@gm.com)  
P 866.446.6963 ext. 5911723  
F 866.476.8227



## Stephanie Washington (C)

---

From: Stephanie Washington (C)  
Sent: Monday, August 31, 2015 9:46 AM  
To: 'Anthony Shimmel'  
Subject: RE: [REDACTED] Dealer Inspection Template

Wonderful! I will be leaving for vacation on Wednesday and will be returning on 9/9/15. I will process pay for the inspection and the repair once I return.

Thank you.....

**Stephanie D. Washington**  
*General Motors Business Resource Center  
Product Assistance Claims Department*  
[stephanie.1.washington@gm.com](mailto:stephanie.1.washington@gm.com)  
P 866.446.6963 ext. 5911723  
F 866.476.8227



---

From: Anthony Shimmel [<mailto:ashimmel@blaisealexander.com>]  
Sent: Friday, August 28, 2015 5:32 PM  
To: Stephanie Washington (C)  
Subject: Re: [REDACTED] Dealer Inspection Template

I already talked to the customer after our phone call. Thank you for all your help.

Sent from my iPhone

On Aug 28, 2015, at 5:08 PM, "Stephanie Washington (C)" <[stephanie.1.washington@gm.com](mailto:stephanie.1.washington@gm.com)> wrote:

Anthony,

Go ahead and give the customer a call we will repair the vehicle.

Thanks,

**Stephanie D. Washington**  
*General Motors Business Resource Center  
Product Assistance Claims Department*  
[stephanie.1.washington@gm.com](mailto:stephanie.1.washington@gm.com)  
P 866.446.6963 ext. 5911723  
F 866.476.8227  
<image003.jpg>

---

From: Anthony Shimmel [<mailto:ashimmel@blaisealexander.com>]  
Sent: Friday, August 28, 2015 2:37 PM  
To: Stephanie Washington (C)

Cc: ashimmel ([blaisealexander.com](mailto:blaisealexander.com))  
Subject: [REDACTED] Dealer Inspection Template

---

From: Anthony Shimmel [<mailto:ashimmel@blaisealexander.com>]  
Sent: Friday, August 28, 2015 8:32 AM  
To: '[stephanie.1.washington@gm.com](mailto:stephanie.1.washington@gm.com)' <[stephanie.1.washington@gm.com](mailto:stephanie.1.washington@gm.com)>  
Subject: [REDACTED] Dealer Inspection Template

Nothing in this message is intended to constitute an electronic signature unless a specific statement to the contrary is included in this message.

Confidentiality Note: This message is intended only for the person or entity to which it is addressed. It may contain confidential and/or privileged material. Any review, transmission, dissemination or other use, or taking of any action in reliance upon this message by persons or entities other than the intended recipient is prohibited and may be unlawful. If you received this message in error, please contact the sender and delete it from your computer.

## Stephanie Washington (C)

---

From: Stephanie Washington (C)  
Sent: Tuesday, August 18, 2015 4:44 PM  
To: Laura Dembeck  
Cc: 'ashimmel@blaisealexander.com'  
Subject: [REDACTED]

Laura Dembeck,

A product allegation claim has been made in your district. Customer alleges she went out started her car up and when she put the vehicle in drive the headlights did not come on so she shut her vehicle off and started it again and still no lights, she had high beams but no low beams so she went to work and on her first brake she called her husband and told him to go get her some headlights, so her husband told her that it is very unlikely for both lights to go out and that he would check it out when she gets home. After dinner her son who is a mechanic opened her hood and opened up her fuse box and you could smell the burn, the module was melted and melted part of the fuse box, it was the daytime running light module. The prongs stayed in the fuse box, it was all melted as well.

Customer Last Name: [REDACTED] n  
2007, Chevrolet, Trailblazer  
VIN: 1GNDDT13S472 [REDACTED]  
Blaise Alexander Chevrolet Buick Of Philipsburg, Philipsburg, PA (281058)  
Anthony Shimmel, Service Manager

**This is only a notification. No action is required on your part at this time.**

Thanks,

**Stephanie D. Washington**  
*General Motors Business Resource Center  
Product Assistance Claims Department*  
[stephanie.l.washington@gm.com](mailto:stephanie.l.washington@gm.com)  
P 866.446.6963 ext. 5911723  
F 866.476.8227





ZIP CODE: 16830 | Sign in (or Sign up)

Home | Car Values | Cars for Sale | Car Reviews | Awards & Top 10s | Research Tools

Popular at KBB.com

2015-16 New Car Buyer's Guide

Advertisement

Why ads?

Home > Car Values > Chevrolet > TrailBlazer > 2007 > Style > Options > LS Sport Utility 4D

Chevrolet TrailBlazer 2007 Go

# Your Blue Book® Value | Find Your Next Car

Show Used Car Prices Print report



## 2007 Chevrolet TrailBlazer

Style: **LS Sport Utility 4D**

Mileage: **121000**

[Edit options](#) | [Check specs](#)

Trade In to a Dealer

Get an Instant Cash Offer

Sell to a Private Party



### Next Step: Find a Car

Browse reviews, photos, specs and more.

### Have a vehicle in mind?

Make

Model

[Recently Viewed Cars](#) | [My Saved Cars](#)



### Good Condition

Trade-in Values valid for your area through 8/27/2015  
Track this car's values

### Instant Cash Offer

Find dealers ready to buy your car - today!

Advertisement

Why ads?

### Tell Us About This Car

Owners like you rated the 2007 TrailBlazer 8.2 out of 10.

## Next Steps to Selling Your Car

### Benchmark Local Prices

See what dealers and private sellers in your area are asking for your car.

### Give Buyers Confidence

Show them a clean AutoCheck vehicle history report and close the deal fast.

Enter VIN (optional)

### List It for Sale

Advertisement

Why ads?

Reach millions of in-market shoppers on KBB.com and AutoTrader.com.

### Free Dealer Price Quote

Get the best price and be more prepared with your free, no-obligation price quote



Advertisement

Why ads?

Advertisement

Why ads?

Search: Find car values or features

[Popular Topics](#)  
[New Cars for 2010](#)  
[Used Cars](#)  
[Cars For Sale](#)  
[Car Buying Guides](#)  
[Car Awards](#)

[Car Reviews & Ratings](#)  
[Car Reviews](#)  
[Car Videos](#)  
[Auto Shows](#)  
[Car News](#)  
[Best Cars](#)

[Help](#)  
[FAQ](#)  
[Site Map](#)  
[Find a New Car](#)  
[What's My Car Worth?](#)  
[KBB Mobile](#)

[Company](#)  
[About Us](#)  
[Contact Us](#)  
[Careers](#)  
[Corporate Information](#)

[Industry Relations](#)  
[Affiliates](#)  
[Media Center](#)  
[Linking Policy](#)  
[Business Solutions](#)

[Follow KBB](#)
[Facebook](#)
[Twitter](#)
[Google+](#)
[YouTube](#)
[LinkedIn](#)
[RSS](#)
[Mobile Apps](#)
[KBB.com](#)
[AutoTrader](#)

© 1995-2015 Kelley Blue Book Co., Inc. All rights reserved. Copyright & Trademarks | Terms of Service | Privacy Policy | Ad Choices

Have comments about our Blue Book Values? Give us your feedback.

© 2015 Kelley Blue Book Co., Inc. All rights reserved. 8/21/2015-8/27/2015 Edition for Pennsylvania 16830. The specific information required to determine the value for this particular vehicle was supplied by the person generating this report. Vehicle valuations are opinions and may vary from vehicle to vehicle. Actual valuations will vary based upon market conditions, specifications, vehicle condition or other particular circumstances pertinent to this particular vehicle or the transaction or the parties to the transaction. This report is intended for the individual use of the person generating this report only and shall not be sold or transmitted to another party. Kelley Blue Book assumes no responsibility for errors or omissions. (v.15083)

**Stephanie Washington (C)**

**From:** Stephanie Washington (C)  
**Sent:** Monday, August 24, 2015 11:55 AM  
**To:** Mickey Sabol; Kimberly Horvath (C)  
**Cc:** Patrick T. Macaluso  
**Subject:** Photos - Melt Case SR# [REDACTED]

Mickey,

Type of case	Melt Case	Allegation/Synopsis
Status	Photos	Customer alleges she went out sta car up and when she put the vehic the headlights did not come on so her vehicle off and started it again no lights, she had high beams but r beams so she went to work and on brake she called her husband and t go get her some headlights, so her told her that it is very unlikely for b to go out and that he would check when she gets home. After dinner who is a mechanic opened her hood opened up her fuse box and you co the burn, the module was melted a part of the fuse box, it was the day running light module. The prongs s the fuse box it was all melted as w
SR Number	[REDACTED]	
Customer Name	[REDACTED]	
Year/Make/Model	2007/Chevrolet/Trailblazer	
VIN	1GNDT13S472 [REDACTED]	
Incident Date	8/10/2015	
Purchase Date	10/1/2007	
Titled in who's name	[REDACTED]	
Purchase Price	18,000	
Open/Closed Recalls	<i>Recall Name/Description/Open or Closed</i>	
Mileage	121,000	
Purchased From	<i>Ken Long Motors who is now Blaise Alexander Chevrolet Buick Of Philipsburg</i>	
Vehicle Insured	Yes	
MSRP/KBB	\$3,783.00	
Additional Information as requested by TC/TL		

Thanks,

***Stephanie D. Washington***

*General Motors Business Resource Center*

*Product Assistance Claims Department*

[stephanie.l.washington@gm.com](mailto:stephanie.l.washington@gm.com)

*P 866.446.6963 ext. 5911723*

*F 866.476.8227*

























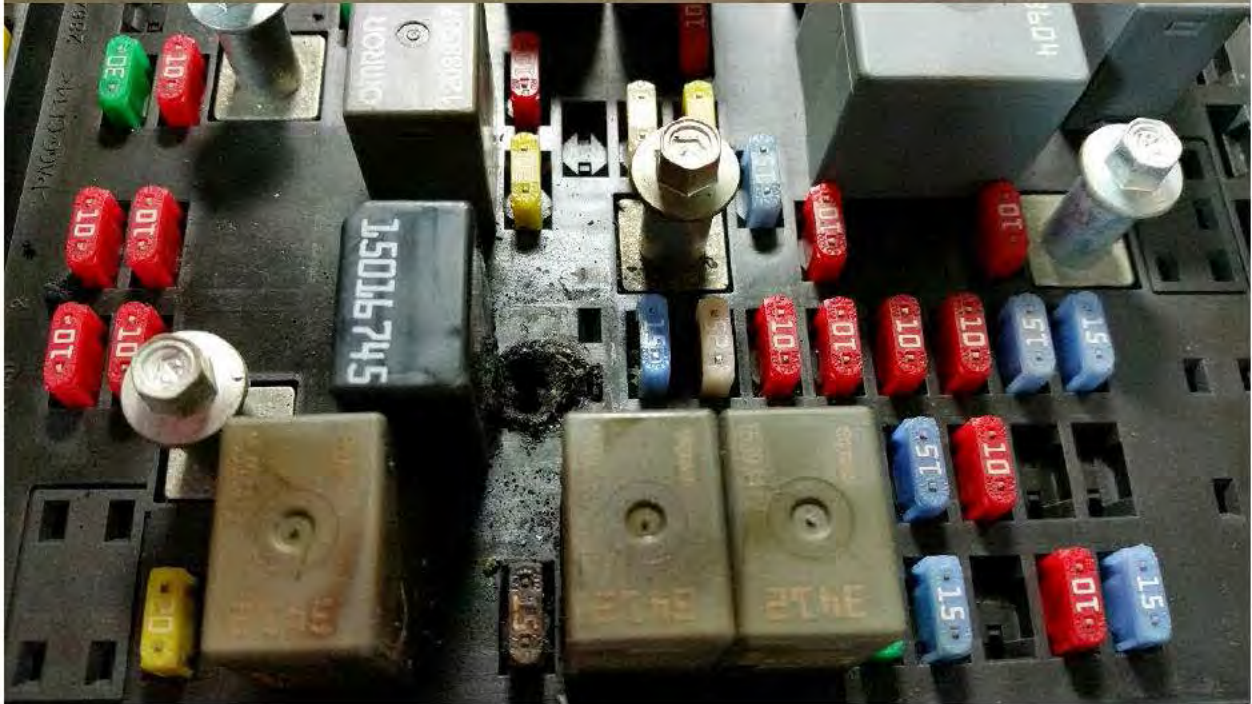





MADE BY GENERAL MOTORS CORP.

GVWR  
2608KG(5750LB)

GAWR FRT  
1338KG(2950LB)

GAWR RR  
1452KG(3200LB)

THIS VEHICLE CONFORMS TO ALL APPLICABLE U.S. FEDERAL MOTOR VEHICLE SAFETY AND THEFT PREVENTION STANDARDS IN EFFECT THE DATE OF MANUFACTURE SHOWN ABOVE.

1GNDT13S472 [REDACTED]

TYPE: M.P.V.

MODEL: T15506

TPNC	TIRE SIZE	SPEED RTG	RIM	COLD TIRE PRESSURE
FRT	P245/65R17	S	17X7J	210KPA(30PSI)
RR	P245/65R17	S	17X7J	240KPA(35PSI)
SPA	P235/75R16	S	16X7J	240KPA(35PSI)

SEE OWNER'S MANUAL FOR MORE INFORMATION.







**Customer**

██████████  
 ██████████  
 Call anytime

**Vehicle**

2007 Chevrolet Trailblazer  
 1GNDT13S47223██████  
 Mileage now: 121000 mi

**Status of vehicle/concern**

A GM Dealer has NOT diagnosed current concern  
 Repairs have not been scheduled  
 Vehicle is currently operable & can be driven

**Key Points**

.Cust I can not afford the cost of having the fuel line repaired. I was sitting in the driveway on Monday. I did not have any lights.. I had the issue with my head lamp module burnt out. I called the dealer and they said that I would have to pay for the diagnosis. I told them I can not afford that. The dealership told me to call you guys and gave me your number.

Customer seeks fuse box replacement.

CRS Advised Are you having any other vehicle issues?

Customer I need the diag waived.

CRS Thank you for sharing this information with me. I am sorry to hear about your vehicle issues. The process to resolution is as follows: The customer experience manager will contact you in 48 hours to touch base with you. If you do not hear from

Supporting Factors	Limiting Factors
Loyal GM customer: 2 GM vehicles purchased (verified)	Vehicle is > 8 years old (verified) Vehicle has > 100,000 miles
<p><i>Please consider these additional questions:</i>                      Close to any applicable expiration limit? (wrnty, spl covg, svc contrt)                      Did cust buy an extd svc contract, but it's expired or n/a?                      Is this a loyal service customer? (to involved dealer)                      Are high dollar customer-pay ROs on record for this cust?                      Is this a conquest buyer?</p>	<p><i>Please consider these additional questions:</i>                      Is vehicle way beyond all applicable expiration limits?                      Does veh have an active <u>aftermarket</u> Extd Svc Contract?                      Did customer buy vehicle outside of warranty?                      Does it seem customer doesn't take care of the vehicle?                      Is cause not normally covered by warranty?                      Is cause due to an accident insurance won't cover?                      Is cause due to damage by independent repair facility?</p>

**Additional key points**

This customer has purchased these GM vehicles (verified): 2007 Trailblazer, 2007 Equinox

**Reference**

CAC SR# ██████████  
 CAC advisor: Lachele--> (866) 790-5600 , Ext # 5911540

### Fire Case template

Type of case	Fire Case	
Status	New	
SR Number	[REDACTED]	
Customer Name (Last name/First Name)	[REDACTED]	
Year/Make/Model	2004 Chevrolet TrailBlazer	
VIN	1GNDS13S7423 [REDACTED]	
Incident Date	8/4/2015	
Purchase Date	a few years ago	
Titled in who's name	[REDACTED]	
Purchase Price	unknown	
Open/Closed Recalls (If closed include closed Transaction History)	<i>no recalls</i>	
Mileage	130,000	
Purchased From	<i>third party</i>	
Vehicle Insured	Yes	
MSRP/KBB (Trade-in Good Value)	\$2,264.00	
Loaner Vehicle (yes/no from drop down and enter date issued)	No	n/a
Additional Information as requested by TC/TL		

Verify before sending E-mail:

**IS THE FORM COMPLETE WITH ALL INFORMATION?**

**Have Photos been attached in Seibel**

please review to ensure photos are clear and show damage

Must include at least one close up showing damage/fire, Overall of damaged area, Broad view to show the envi

**One Call Handling: Please include in body of email why case is being closed on the first "new email".**

If necessary include copy of any additional fire/police reports, dealer inspections, and copy of title and registration.

If you are handling a case that requires ESISQFYI activity please confirm that this activity has been completed in the system.

All fire cases with ESISQFYI requires email notification to the TC and TCL regardless if case remains open or closed.

Case Summary

customer alleged the vehicle relay fuse box caught on fire; the vehicle has been repaired ; customer submitted a photo of the fuse relay and a receipt requesting reimbursement for review; advised customer I would submit and follow up; documents attached to SR

To: Mickey.sabol@gm.com

Cc: Kimberly.horvath@gm.com

Subject: New - Fire Case SR# [REDACTED]

PASTE TEMPLATI

ronment surrounding the area and a photo of all four sides of vehicle exterior.

on as necessary.

n Siebel prior to sending the Fire Case Initial Email to the Fire Team.  
ed on first contact.

E IN EMAIL USING CTRL+V



Fire Case  
Smoke Case  
Melt Case

New  
Reopen  
Photos  
Update  
Inspection received  
Question

Closed

*Estimate is*

Yes

No





**Kelley Blue Book** The Trusted Resource®



Advertisement

# 2004 Chevrolet TrailBlazer Pricing Report



**Style:** LS Sport Utility 4D  
**Mileage:** 130,000

Trade In to a Dealer



Trade-in Values valid for your area through 8/27/2015  
Good Condition

## Vehicle Highlights

- |   |                                    |
|---|------------------------------------|
| Fuel Economy:<br>City 14/Hwy 19/Comb 16 MPG | Max Seating: 5                     |
| Doors: 4                                    | Engine: 6-Cyl, 4.2 Liter           |
| Drivetrain: 4WD                             | Transmission: Automatic            |
| EPA Class: Sport Utility Vehicles           | Body Style: Sport Utility          |
| Country of Origin: United States            | Country of Assembly: United States |

## Your Configured Options

Our pre-selected options, based on typical equipment for this car.

✓ Options that you added while configuring this car.

### Engine

6-Cyl, 4.2 Liter

### Transmission

Automatic

### Drivetrain

4WD

### Braking and Traction

ABS (4-Wheel)

### Comfort and Convenience

- Air Conditioning
- Power Windows
- Power Door Locks

### Steering

- Power Steering
- Tilt Wheel

### Entertainment and Instrumentation

- AM/FM Stereo
- CD (Single Disc)

### Safety and Security

- Dual Air Bags

### Cargo and Towing

- Towing Pkg

### Wheels and Tires

- Alloy Wheels

## Glossary of Terms

**Kelley Blue Book® Trade-in Value** - This is the amount you can expect to receive when you trade in your car to a dealer. This value is determined based on the style, condition, mileage and options indicated.

**Trade-In Range** - The Trade-In Range is Kelley Blue Book's estimate of what you can reasonably expect to receive this week based on the style, condition, mileage and options of your vehicle when you trade it in to a dealer. However, every dealer is different and values are not guaranteed.

### Tip:

It's crucial to know your car's true condition when you sell it, so that you can price it appropriately. Consider having your mechanic give you an objective report.

**Kelley Blue Book® Private Party Value** - This is the starting point for negotiation of a used-car sale between a private buyer and seller. This is an "as is" value that does not include any warranties. The final price depends on the car's actual condition and local market factors.

**Private Party Range** - The Private Party Range is Kelley Blue Book's estimate of what you can reasonably expect to receive this week for a vehicle with stated mileage in the selected condition and configured with your selected options, excluding taxes, title and fees when selling to a private party.

**Excellent Condition** - 3% of all cars we value. This car looks new and is in excellent mechanical condition. It has never had paint or bodywork and has an interior and body free of wear and visible defects. The car is rust-free and does not need reconditioning. Its clean engine compartment is free of fluid leaks. It also has a clean title history, has complete and verifiable service records and will pass safety and smog inspection.

**Very Good Condition** - 23% of all cars we value. This car has minor wear or visible defects on the body and interior but is in excellent mechanical condition, requiring only minimal reconditioning. It has little to no paint and bodywork and is free of rust. Its clean engine compartment is free of fluid leaks. The tires match and have 75% or more of tread. It also has a clean title history, with most service records available, and will pass safety and smog inspection.

**Good Condition** - 54% of all cars we value. This car is free of major mechanical problems but may need some reconditioning. Its paint and bodywork may require minor touch-ups, with repairable cosmetic defects, and its engine compartment may have minor leaks. There are minor body scratches or dings and minor interior blemishes, but no rust. The tires match and have 50% or more of tread. It also has a clean title history, with some service records available, and will pass safety and smog inspection.

**Fair Condition** - 18% of all cars we value. This car has some mechanical or cosmetic defects and needs servicing, but is still in safe running condition and has a clean title history. The paint, body and/or interior may need professional servicing. The tires may need replacing and there may be some repairable rust damage.

---

© 1995-2015 Kelley Blue Book Co.<sup>®</sup>, Inc. All rights reserved.

© 2015 Kelley Blue Book Co., Inc. All rights reserved. 8/21/2015-8/27/2015 Edition for Texas 78245. The specific information required to determine the value for this particular vehicle was supplied by the person generating this report. Vehicle valuations are opinions and may vary from vehicle to vehicle. Actual valuations will vary based upon market conditions, specifications, vehicle condition or other particular circumstances pertinent to this particular vehicle or the transaction or the parties to the transaction. This report is intended for the individual use of the person generating this report only and shall not be sold or transmitted to another party. Kelley Blue Book assumes no responsibility for errors or omissions. (v.15083)

# GENE BROWN'S AABCO TRANSMISSIONS

9045 Grissom Road  
 San Antonio, TX 78251  
 (210) 647-4747

DATE INVOICE #

Date	Invoice #
8/13/2015	[REDACTED]



"An Independently Owned and Operated  
 Gene Brown's AABCO Transmission Center"

Bill To
[REDACTED]
[REDACTED] BEND S.A. TX. [REDACTED]
2004 CHEVY TRAILBLAZER
MI:201888 LP# AZO-[REDACTED]

Original Mileage			
Towing	YES	NO	Svc. Mgr.

Description	Amount
DIAGNOSTIC CHECK : ELECTRICAL PROBLEMS , FOUND THAT FUSE RELAY CENTER UNDER HOOD WAS SHORTING OUT AND CAUGHT ON FIRE WHICH COULD HAVE BURNED COMPLETE VEHICLE , CUSTOMER WAS INFORMED THAT COMPLETE ENGINE FUSE RELAY CENTER NEEDS BE REPLACED AND ALL ELECTRICAL WIRING NEEDS TO BE INSPECTED	145.00
TRACE AND REPAIR ELECTRICAL AND COMPUTER PROBLEMS GOING TO FUSE RELAY CENTER , REMOVE AND REPLACE FUSE RELAY CENTER	345.00
PARTS: FUSE RELAY CENTER PART# 15196419 SEE ATTACHED PICTURE	622.70
SHOP SUPPLIES : CLEANERS, ASSEMBLY GREASE , ASSEMBLY LUBE , PAINT , THREADLOCK SEAL, SILICONE, WASTE FEE'S	45.00
GAS	20.00
TAX	51.37
12 MO. OR 12,000 MILE LIMITED WARRANTY ON WORK PERFORMED ONLY , WARRANTY COVERS PARTS AND LABOR ONLY , NO TOWING	

I hereby authorize the above repair work to be done with necessary materials. You and your employees may operate above vehicle for purposes of testing, inspection or delivery at my risk. An express mechanic's lien is acknowledged on above vehicle to secure the amount of repairs thereto. You will not be held responsible for loss or damage to vehicle or articles left in vehicle in case of fire, theft, accident or any other cause beyond your control.

Authorized By \_\_\_\_\_

**Total**

<b>TOTAL:</b>	
CASH	\$1,229.07
CERT. CHECK	
CREDIT CARD	
CHARGE	

L - Light Truck >2004 >T - 56S - Trailblazer/Envoy/Rainier/Bravada (4WD/AWD) >02 - STARTER-GENERATOR-IGNITION-ELECTRICAL-  
LAMPS >(TS02-204) 2004-2005 ST(06-36) BLOCK/ACCESSORY WIRING JUNCTION >

TS02-204 10/28/2004

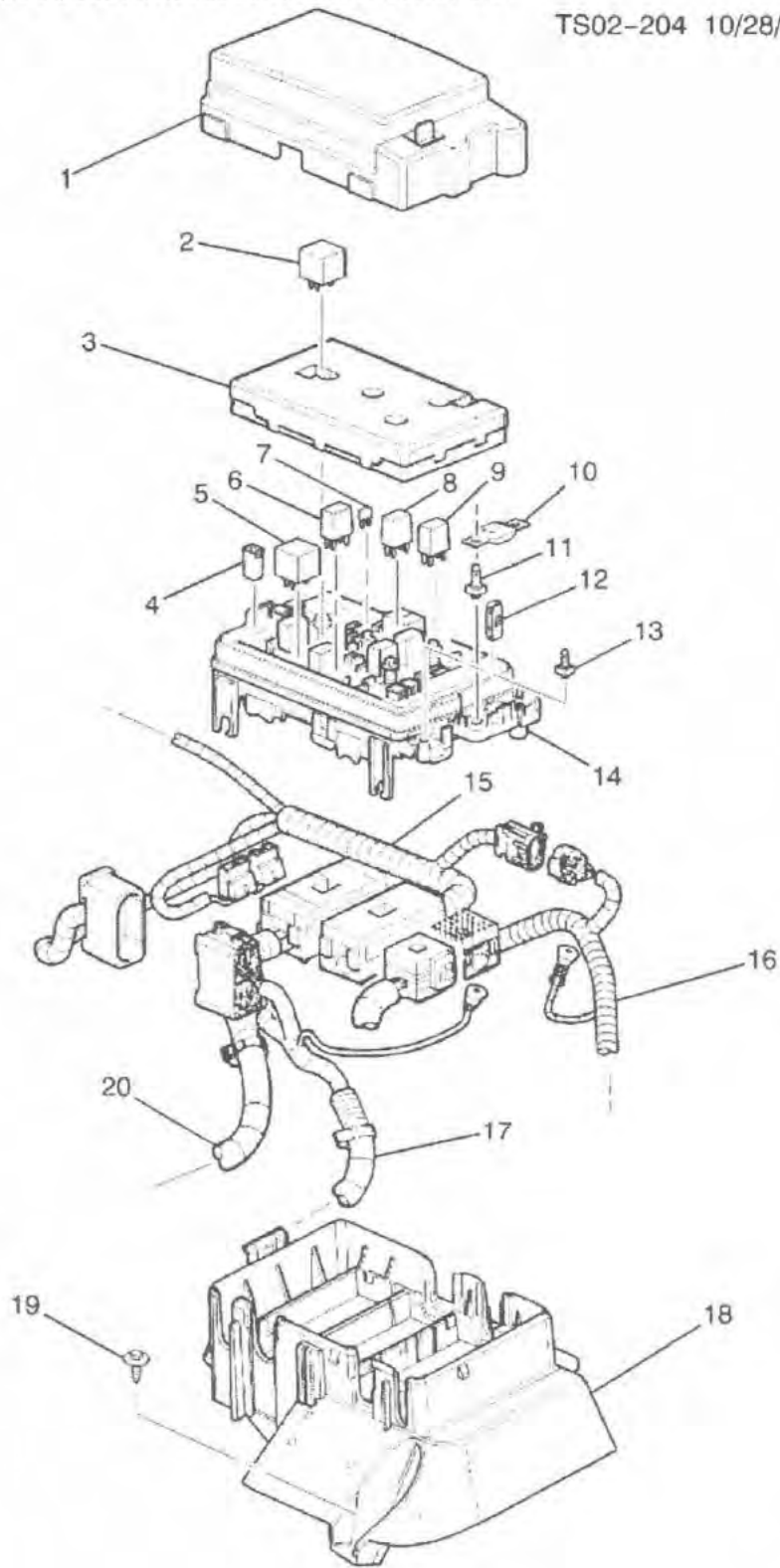

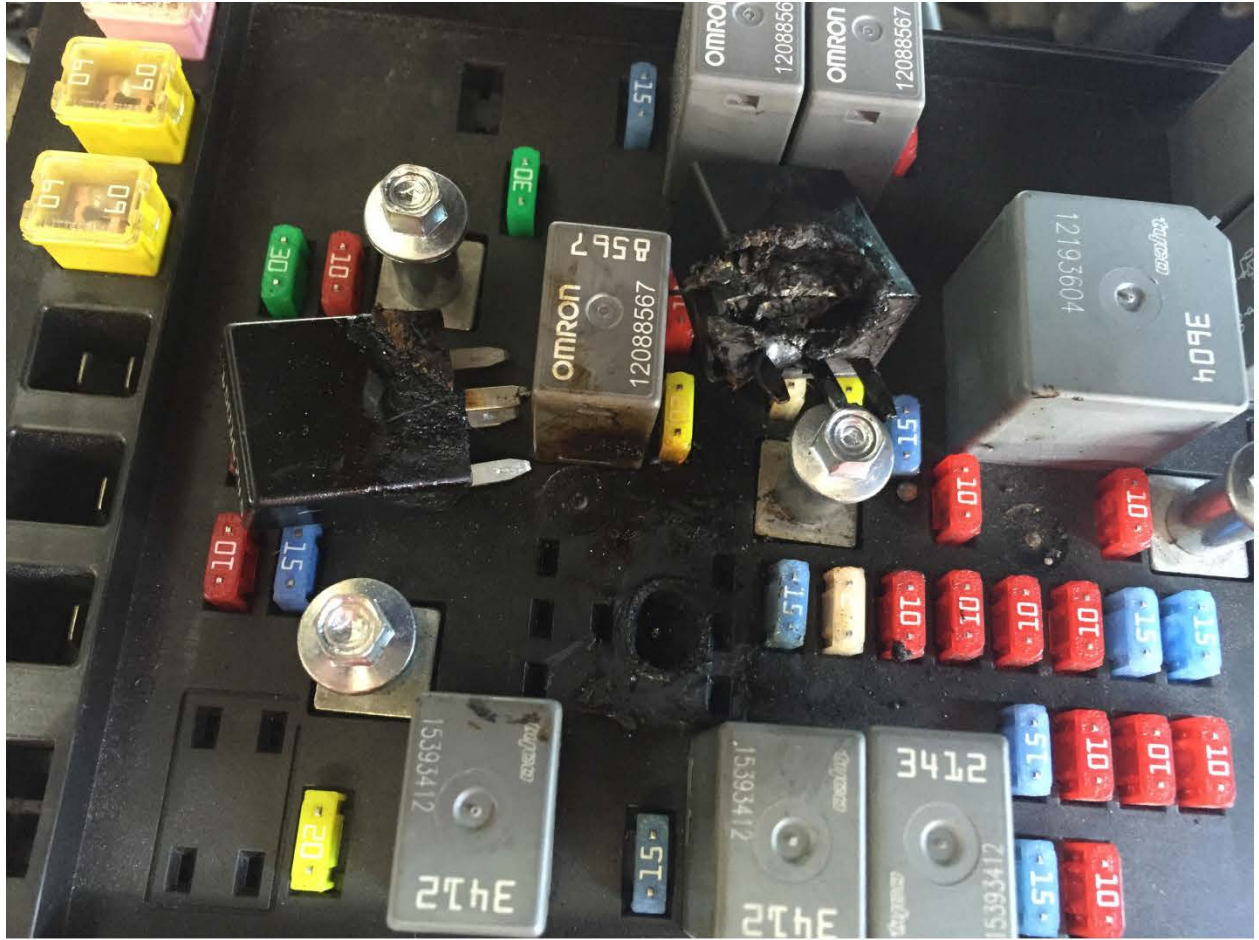

Connecting.....A live chat agent is now entering the chat.

Caller English

System [2:36:10 PM]:

Welcome to chat.

Akida [2:36:38 PM]:

Hello C [REDACTED]! Thank you for contacting Buick Customer Assistance, my name is Akida, how may I help you today?

[REDACTED] [2:37:03 PM]:

Do you have any idea when a recall schedule for the head lights shutting off on the Buick Lacrosse will be released?

Akida [2:38:15 PM]:

Thank you for taking the time to chat in with us today! I'm sorry, recalls are not on a schedule of any kind. Unfortunately, I don't know the parameters of how, if, nor when a recall will be released for a particular issue. However, if I may have your VIN, I can check for recalls on your vehicle if you would like?

[REDACTED] [2:40:15 PM]:

My VIN is 2G4WD582481 [REDACTED].

Akida [2:41:34 PM]:

Thank you. I do see a recall for your LaCrosse. It's for: UNINTENDED IGNITION KEY ROTATION. Here's a link with more information for you:

Akida [2:41:37 PM]:

[https://recalls.gm.com/#/?vin=2G4WD5824811\[REDACTED\]](https://recalls.gm.com/#/?vin=2G4WD5824811[REDACTED])

Akida [2:41:54 PM]:

I don't see a recall having to do with your headlights however.

[REDACTED] [2:43:30 PM]:

I know about that one. This is the recall I am talking about

<http://www.usatoday.com/story/money/cars/2014/12/01/gm-headlights-recall/19748153/>

Akida [2:45:10 PM]:

I'm sorry, that recall isn't attached to your LaCrosse so no, you don't have that.

[REDACTED] [2:46:16 PM]:

Well then I need to know how to fill a complaint because my car is doing this. It has been for a few months but last night it left me stranded out in the desert with two kids and no cell phone service.

Akida [2:48:44 PM]:

You're in the correct place to file a formal complaint. What specifically would you like your complaint to be? Meaning, would you prefer to complain that your LaCrosse doesn't have the recall, that your LaCrosse is having this particular issue, or both?

[REDACTED] [2:49:15 PM]:

Both I guess

Akida [2:49:35 PM]:

Thank you. Roughly how many miles do you have on your LaCrosse?

[REDACTED] [2:49:53 PM]:

55,000

Akida [2:51:14 PM]:

Thank you. I've documented your complaint regarding this issue. Your Service Request Number (also called an SR or Case number) is [REDACTED].

[REDACTED] [2:51:37 PM]:

Thank you very much. What do I need to do from here?

Akida [2:52:40 PM]:

When it comes to your complaint, there isn't anything else needed to be done. As for your headlight issue, I would recommend taking your LaCrosse to your local Buick dealership to have them diagnose what may be causing this issue for you.

[REDACTED] [2:53:37 PM]:

OK my concern being that if my car does in fact need to be in this recall I do not want to pay for the repairs.

Akida [2:55:07 PM]:

Unfortunately, as your LaCrosse doesn't have a recall attached to it regarding this issue as recalls are VIN specific, so it is already not included in that particular recall. With that being the case, you will be responsible for any cost associated with repairing this issue.

[REDACTED] [2:55:55 PM]:

Then what is the point of filing a complaint if GM is going to do anything?

Akida [2:56:16 PM]:

However, if you pay for this issue, and your LaCrosse is later added to the recall list, you will have the option to be reimbursed for the repairs.

[REDACTED] [2:56:30 PM]:

Thank you Akida.

[REDACTED] [2:56:42 PM]:

Have a great day!

Akida [2:56:54 PM]:

You're welcome! If you have any other questions, please don't hesitate to come back and chat with us. We are here to chat Monday through Friday from 8:00 a.m. to 11:00 p.m., Saturday from 9:00 a.m. to 11:00 p.m. and Sunday 12:00 p.m. to 9:00 p.m. Eastern time.

## PRTS Dynamics - Complete Report

Issue Number: US	Issue Age: 225	Issue (Aftersales) Product Type: Report	Issue Status: Closed
		Current Step: Solution Feedback	Current Step Status: Complete
			Current Step 21-Target: NOV-2003
Project: US-United States Program: TrailBlazer / GMNA Truck Subject: BCM SOFTWARE,Interior - DRL disable after BCM replacement* Product Line: STmidtruck-Global Midsize Truck Project Number: Current 305/360/370			
Associated Issues:		Tasks:	Attachments: 4
			Memos: 2

### REPORT

<b>Main</b>					
<i>User Role Assignments</i>					
Role	Assignment Date	Name	Department	Phone	
Originator	11-MAR-2003	Susan Anderson	General Motors *** Corp Strategy, Bus Dev & Global Plan'g & Program Mgmt. *** New Business Initiatives *** Saab *** Saab Cars NA *** Saab Cars NA Aftersales & Business Development *** P&A Aftersales		
<i>Step Dates</i>					
Step Start Date	Target Submit Date	Actual Submit Date	Target Close Date	Actual Close Date	
11-MAR-2003		11-MAR-2003		11-MAR-2003	
<i>Step Actions</i>					
Action	Date	Name	Department	Phone	Comment
Submitted	11-MAR-2003	Susan Anderson	General Motors *** Corp Strategy, Bus Dev & Global Plan'g & Program Mgmt. *** New Business Initiatives *** Saab *** Saab Cars NA *** Saab Cars NA Aftersales & Business Development *** P&A Aftersales		Submitted by migration
Approved	11-MAR-2003	Susan Anderson	General Motors *** Corp Strategy, Bus Dev & Global Plan'g & Program Mgmt. *** New Business Initiatives *** Saab *** Saab Cars NA *** Saab Cars NA Aftersales & Business Development *** P&A Aftersales		Approved by migration
Originated	11-MAR-2003	Susan Anderson	General Motors *** Corp Strategy, Bus Dev & Global Plan'g & Program Mgmt. *** New Business Initiatives *** Saab *** Saab Cars NA *** Saab Cars NA Aftersales & Business Development *** P&A Aftersales		

<b>Issue Definition</b>	
Vehicle Line/Engineering Source:	TrailBlazer / GMNA Truck
Product Line:	STmidtruck-Global Midsize Truck
Project Number:	Current 305/360/370
Country:	US-United States

## PRTS Dynamics - Complete Report

<b>Issue Title</b>	Part Name: BCM SOFTWARE Part Location: Interior Complaint: DRL disable after BCM replacement* Severity: 4-Annoyance / Continuous improvement. Restricted Issue: No
--------------------	--

<b>Affected Vehicles</b>					
Model Year(s): <input type="text" value="2002"/>	Other Potentially Affected Vehicle Lines: <table border="1" style="width: 100%; border-collapse: collapse;"> <tr><td>Envoy XL-GMC Extended SUV</td></tr> <tr><td>Envoy-GMC SUV</td></tr> <tr><td>Bravada-Oldsmobile SUV</td></tr> <tr><td>TrailBlazer EXT</td></tr> </table>	Envoy XL-GMC Extended SUV	Envoy-GMC SUV	Bravada-Oldsmobile SUV	TrailBlazer EXT
Envoy XL-GMC Extended SUV					
Envoy-GMC SUV					
Bravada-Oldsmobile SUV					
TrailBlazer EXT					
Steering Type: LHD-Left Hand Drive Body Style(s): Axles: Relevant Options:	Engine(s): Transmission(s): Transfer Case: Local Component PR: No				

<b>VIN Information</b>						
<i>Cases</i>						
No of Cases:	Recorded by/Originator			Recorded Date		
1	FIND-21 Migration			02-NOV-2007		
<i>VIN Information</i>						
Primary (VIN)	VIN	Build Date	Engine No	Odometer Reading	Odometer Units	Transmission No
Y	1GNDS13S12 [REDACTED]			0	Kilometers	

<b>Problem Description</b>	
<i>Symptoms/Complaints:</i>	
After replacing the BCM (using the VCI #) in an 02 Trailblazer, the ability to disable DRL & auto headlamps is lost. See TAC cas [REDACTED] After replacing the BCM (using the VCI #) in an 02 Trailblazer, the ability to disable DRL & auto headlamps is lost. See TAC cas [REDACTED]	
<i>Probable Cause:</i>	
Newer software used in the BCM currently does not allow the disable function. Newer software used in the BCM currently does not allow the disable function.	
<i>Corrective Action:</i>	
Daytime Running Lamp Feature Cannot Be Disabled After BCM Replacement (Update BCM Software) #03-08-42-010 - (09/11/2003) Daytime Running Lamp Feature Cannot Be Disabled After BCM Replacement (Update BCM Software) #03-08-42-010 - (09/11/2003)	
Driving Conditions: Road Surface: Success of Corrective Action: 100% Trouble Codes Affected:	Environmental Conditions: Action Requested: <input type="text" value="Field Remedy"/>
<i>Remarks:</i>	

## PRTS Dynamics - Complete Report

vppsl4\_t=Personalization FR  
Migrated Issue: Loaded

### Affected Parts

#### VPPS

1st Level (VPPS): 80-Electrical Function  
2nd Level (VPPS): 80.03-Body Interior & Exterior  
3rd Level (VPPS): 80.03.06-Electronic Body Module  
4th Level (VPPS):

#### Parts

Primary Part	Part Name	Part Number	Supplier Name	Part Year	DUNS Code	Catalog Number	Deck Code	Serial/Casting Number
--------------	-----------	-------------	---------------	-----------	-----------	----------------	-----------	-----------------------

Suspect Parts Available? No

#### Shipping Details:

#### Location of Parts:

#### Remarks:

### Labor Information

#### Labor Codes Information

Primary	Labor Code
Y	N4808

### Dealer and Field Contact Information

#### Dealer

Dealer Number:  
Dealer Name:  
Dealer Phone:  
Dealer Contact:  
Dealer Email Address:

#### Field Representative

Field Rep Contact Name:  
Field Rep Number:  
Field Rep Phone:  
Field Rep Email Address:

### Impact Info -> Impacted Product Lines

#### Impacted Product Lines

Product Line	Project Number	Bypass Prioritization	Prioritization Ranking By	Priority Value
STmidtruck	Current 305/360/370	N		

### External Systems

#### System References

## PRTS Dynamics - Complete Report

External System Name	External System Issue ID
Legacy FIND-21	0812/2003/US

<b>Issue Status</b>
<i>Issue Status</i>

<b>Next Step</b>				
<i>Next Step Role Assignments</i>				
Role Name	Assignment Date	Name	Department	Phone
Champion	11-MAR-2003	Donald Sherman	UNKNOWN ORG	
<i>Next Step Target Dates</i>				
Next Step Target Submit Date:			Next Step Target Approve/Close Date:	

## PRTS Dynamics - Complete Report

**SENT**

Main					
<i>User Role Assignments</i>					
Role	Assignment Date	Name	Department	Phone	
Champion	11-MAR-2003	Donald Sherman	UNKNOWN ORG		
<i>Step Dates</i>					
Step Start Date	Target Submit Date	Actual Submit Date	Target Close Date	Actual Close Date	
11-MAR-2003		11-MAR-2003		11-MAR-2003	
<i>Step Actions</i>					
Action	Date	Name	Department	Phone	Comment
Submitted	11-MAR-2003	Susan Anderson	General Motors *** Corp Strategy, Bus Dev & Global Plan'g & Program Mgmt. *** New Business Initiatives *** Saab *** Saab Cars NA *** Saab Cars NA Aftersales & Business Development *** P&A Aftersales		Submitted by migration
Approved	11-MAR-2003	Susan Anderson	General Motors *** Corp Strategy, Bus Dev & Global Plan'g & Program Mgmt. *** New Business Initiatives *** Saab *** Saab Cars NA *** Saab Cars NA Aftersales & Business Development *** P&A Aftersales		Approved by migration

Supporting Processes	
Trigger Question: Step when issue is flagged: Flagged by:	Trigger Answer: Date when issue was flagged:

Issue Status
<i>Issue Status:</i>

Next Step				
<i>Next Step Role Assignments</i>				
Role Name	Assignment Date	Name	Department	Phone
Champion	11-MAR-2003	Donald Sherman	UNKNOWN ORG	
<i>Next Step Target Dates</i>				
Next Step Target Submit Date:		Next Step Target Approve/Close Date: 10-JUN-2003		

## PRTS Dynamics - Complete Report

### ADD. INFO NEEDED

Main					
<i>User Role Assignments</i>					
Role	Assignment Date	Name	Department	Phone	
Champion	11-MAR-2003	Donald Sherman	UNKNOWN ORG		
<i>Step Dates</i>					
Step Start Date	Target Submit Date	Actual Submit Date	Target Close Date	Actual Close Date	
11-MAR-2003		27-MAY-2003	10-JUN-2003	27-MAY-2003	
<i>Step Actions</i>					
Action	Date	Name	Department	Phone	Comment
Approved	27-MAY-2003	Donald Sherman	UNKNOWN ORG		Approved by migration
Submitted	27-MAY-2003	Donald Sherman	UNKNOWN ORG		Submitted by migration

24 Hour Information	
24 Hour: No	Source of Information:
<i>24 Hour CDP Group Information</i>	
Natural owner of problem:	
Name of Natural owner of problem:	

Affected Vehicles					
Model Year(s): 2002  Steering Type: LHD-Left Hand Drive Body Style(s): Axles: Relavent Options:	Other Potentially Affected Vehicle Lines: <table border="1" style="width: 100%; border-collapse: collapse;"> <tr><td>Envoy XL-GMC Extended SUV</td></tr> <tr><td>Envoy-GMC SUV</td></tr> <tr><td>Bravada-Oldsmobile SUV</td></tr> <tr><td>TrailBlazer EXT</td></tr> </table> Engine(s): Transmission(s): Transfer Case: Local Component PR: No	Envoy XL-GMC Extended SUV	Envoy-GMC SUV	Bravada-Oldsmobile SUV	TrailBlazer EXT
Envoy XL-GMC Extended SUV					
Envoy-GMC SUV					
Bravada-Oldsmobile SUV					
TrailBlazer EXT					

VIN Information						
<i>Cases</i>						
No of Cases	Recorded by/Originator	Recorded Date				
1	FIND-21 Migration	02-NOV-2007				
<i>VIN Information</i>						
Primary (VIN)	VIN	Build Date	Odometer Reading	Odometer Units	Transmission No	Engine No
Y	1GNDS13S1 [REDACTED]		0	Kilometers		

Problem Description

## PRTS Dynamics - Complete Report

### Symptoms/Complaints:

After replacing the BCM (using the VCI #) in an 02 Trailblazer, the ability to disable DRL & auto headlamps is lost. See TAC case #6274902

After replacing the BCM (using the VCI #) in an 02 Trailblazer, the ability to disable DRL & auto headlamps is lost. See TAC case #6274902

### Probable Cause:

Newer software used in the BCM currently does not allow the disable function.

Newer software used in the BCM currently does not allow the disable function.

### Corrective Action:

Daytime Running Lamp Feature Cannot Be Disabled After BCM Replacement (Update BCM Software) #03-08-42-010 - (09/11/2003)

Daytime Running Lamp Feature Cannot Be Disabled After BCM Replacement (Update BCM Software) #03-08-42-010 - (09/11/2003)

Driving Conditions:

Environmental Conditions:

Road Surface:

Action Requested: Field Remedy

Success of Corrective Action: 100%

Trouble Codes Affected:

### Remarks:

vppsl4\_t=Personalization FR

Migrated Issue: Loaded

## Develop Solution

### Last Break Point

Date	VIN/Part Number	Comment

### General Answer/Comment:

VSSMBB article-----

Loss of Daytime Running Lights Disable Feature after BCM Replacement

All 2002 Chevrolet Trailblazer, Trailblazer EXT, GMC Envoy, Envoy XL, and Oldsmobile Bravada

Susan Anderson 586-575-8260

Some customers may mention they are unable to disable the DRL feature when following the procedure in the owner's manual. This condition may be present after having a BCM replaced during a previous service visit. In the 2002 models, DRL is disabled by pressing the dome override button four times within six seconds with the ignition in the run position. A chime sounds to confirm the system is off.

After replacing the BCM with new part number #15065293 the system will function as designed for the 2003 model year which has a 4 position headlight switch including a DRL disable position. Due to additional wiring harness changes between 2002 and 2003 models, the 4-position switch will not correct the DRL disable feature on 2002 models. Do not attempt to change the headlamp switch.

A calibration to restore the DRL disable feature is currently in process and a Service Bulletin will be released to inform you when it is available.

### Short Description:

VSSMBB - 3/13/2003

TAC PI - 3/13/2003

DLRVME 3/13/2003

### Field Service Information

PI Number:

## PRTS Dynamics - Complete Report

Bulletin Number:  
GM Messenger Date:

*Field Remedy:*

*Production Remedy:*

### Affected Parts

**VPPS**

1st Level (VPPS): 80-Electrical Function  
 2nd Level (VPPS): 80.03-Body Interior & Exterior  
 3rd Level (VPPS): 80.03.06-Electronic Body Module  
 4th Level (VPPS):

**Part**

Primary Part	Part Number	Part Name	Supplier Name	Part Year	DUNS Code	Catalog Number	Deck Code	Serial Casting Number
--------------	-------------	-----------	---------------	-----------	-----------	----------------	-----------	-----------------------

Suspect Parts Available? No

*Shipping Details:*

*Location of Parts:*

*Remarks:*

### Labor Information

**Labor Codes Information**

Primary	Labor Code
Y	N4808

### Dealer and Field Contact Information

**Dealer**

Dealer Number:  
 Dealer Name:  
 Dealer Phone:  
 Dealer Contact:  
 Dealer Email Address:

**Field Representative**

Field Rep Contact Name:  
 Field Rep Number:  
 Field Rep Phone:  
 Field Rep Email Address:

### Supporting Processes

Trigger Question:  
Step when issue is flagged:

Trigger Answer:  
Date when issue was flagged:

# PRTS Dynamics - Complete Report

Flagged by:

## Impact Info -> Impacted Product Lines

### Impacted Product Lines

Product Line	Project Number	Bypass Prioritization	Prioritization Ranking By	Priority Value
STmidtruck	Current 305/360/370	N		

## Impact Info -> Aftersales

### Aftersales Comments:

### Aftersales Impact Metrics Information

Metric	Number of Cases

## Customer Satisfaction

### Customer Satisfaction Question

Product Line	Project Number	Available Data
STmidtruck	Current 305/360/370	No

### Customer Survey Information

Product Line	Project Number	Impact Category	Survey	Survey Category	Wave	Total PPH	Option PPH	Reference PPH	Satisfaction	Satisfaction Reference	PPH	Model Year

Report Date:

### Customer Survey Comments

## Warranty

### Warranty Question

Product Line	Project Number	Available Data
STmidtruck	[REDACTED]	No

### Labor Codes Information

Primary	Labor Code
Y	N4808

### Warranty Measure Information

Product Line	Project Number	Impact Category	Warranty Measure	Sales Region	0 MIS	2 MIS	6MIS	12 MIS	24 MIS	36 MIS	Model Year	Calendar Year	Currency Type	Report Date

### Solution Effectiveness (%) Information

Product Line	Project Number	Solution Effectiveness (%)

Report Date:

### Warranty Comment

## Issue Status

### Issue Status

## Next Step

## *PRTS Dynamics - Complete Report*

### ***Next Step Role Assignments***

Role Name	Assignment Date	Name	Department	Phone
Champion	27-MAY-2003	Donald Sherman	UNKNOWN ORG	

### ***Next Step Target Dates***

Next Step Target Submit Date: 26-JUN-2003

Next Step Target Approve/Close Date: 10-OCT-2003

## PRTS Dynamics - Complete Report

### OPEN

Main					
<i>User Role Assignments</i>					
Role	Assignment Date	Name	Department		Phone
Champion	27-MAY-2003	Donald Sherman	UNKNOWN ORG		
<i>Step Dates</i>					
Step Start Date	Target Submit Date	Actual Submit Date	Target Close Date	Actual Close Date	
27-MAY-2003	26-JUN-2003	07-OCT-2003	10-OCT-2003	22-OCT-2003	
<i>Step Actions</i>					
Action	Date	Name	Department	Phone	Comment
Submitted	07-OCT-2003	Donald Sherman	UNKNOWN ORG		Submitted by migration
Approved	22-OCT-2003	Melissa Clifford	UNKNOWN ORG	+1 586 947 3475 No V	Approved by migration

24 Hour Information	
	24 Hour: No
Source of Information:	
<i>24 Hour CDP Group Information</i>	
Natural owner of problem:	
Name of Natural owner of problem:	

Affected Vehicles					
Model Year(s): <input type="text" value="2002"/>  Steering Type: LHD-Left Hand Drive Body Style(s): Axles: Relavent Options:	Other Potentially Affected Vehicle Lines: <table border="1" style="width: 100%; border-collapse: collapse; margin-top: 5px;"> <tr><td>Envoy XL-GMC Extended SUV</td></tr> <tr><td>Envoy-GMC SUV</td></tr> <tr><td>Bravada-Oldsmobile SUV</td></tr> <tr><td>TrailBlazer EXT</td></tr> </table> Engine(s): Transmission(s): Transfer Case: Local Component PR: No	Envoy XL-GMC Extended SUV	Envoy-GMC SUV	Bravada-Oldsmobile SUV	TrailBlazer EXT
Envoy XL-GMC Extended SUV					
Envoy-GMC SUV					
Bravada-Oldsmobile SUV					
TrailBlazer EXT					

VIN Information						
<i>Cases</i>						
No of Cases	Recorded by/Originator			Recorded Date		
1	FIND-21 Migration			02-NOV-2007		
<i>VIN Information</i>						
Primary (VIN)	VIN	Build Date	Engine No	Odometer Reading	Odometer Units	Transmission No
Y	1GNDS13S122			0	Kilometers	

## PRTS Dynamics - Complete Report

<b>Problem Description</b>	
<b>Symptoms/Complaints:</b>	
After replacing the BCM (using the VCI #) in an 02 Trailblazer, the ability to disable DRL & auto headlamps is lost. See TAC case # [REDACTED]	
After replacing the BCM (using the VCI #) in an 02 Trailblazer, the ability to disable DRL & auto headlamps is lost. See TAC case # [REDACTED]	
<b>Probable Cause:</b>	
Newer software used in the BCM currently does not allow the disable function.	
Newer software used in the BCM currently does not allow the disable function.	
<b>Corrective Action:</b>	
Daytime Running Lamp Feature Cannot Be Disabled After BCM Replacement (Update BCM Software) #03-08-42-010 - (09/11/2003)	
Daytime Running Lamp Feature Cannot Be Disabled After BCM Replacement (Update BCM Software) #03-08-42-010 - (09/11/2003)	
<b>Driving Conditions:</b> <b>Road Surface:</b> <b>Success of Corrective Action:</b> 100% <b>Trouble Codes Affected:</b>	<b>Environmental Conditions:</b> <b>Action Requested:</b> Field Remedy
<b>Remarks:</b>	
vppsl4_t=Personalization FR Migrated Issue: Loaded	

<b>Develop Solution</b>		
<b>Last Break Point</b>		
Date	VIN/Part Number	Comment
<b>General Answer/Comment:</b>		
VSSMBB article-----		
<p>Loss of Daytime Running Lights Disable Feature after BCM Replacement            All 2002 Chevrolet TrailBlazer, Trailblazer EXT, GMC Envoy, Envoy XL, and Oldsmobile Bravada            Susan Anderson 586-575-8260</p> <p>Some customers may mention they are unable to disable the DRL feature when following the procedure in the owner's manual. This condition may be present after having a BCM replaced during a previous service visit. In the 2002 models, DRL is disabled by pressing the dome override button four times within six seconds with the ignition in the run position. A chime sounds to confirm the system is off.</p> <p>After replacing the BCM with new part number #15065293 the system will function as designed for the 2003 model year which has a 4 position headlight switch including a DRL disable position. Due to additional wiring harness changes between 2002 and 2003 models, the 4-position switch will not correct the DRL disable feature on 2002 models. Do not attempt to change the headlamp switch.</p> <p>A calibration to restore the DRL disable feature is currently in process and a Service Bulletin will be released to inform you when it is available.</p>		
<b>Short Description:</b>		
VSSMBB - 3/13/2003 TAC PI - 3/13/2003 DLRVME 3/13/2003		
<b>Field Service Information</b>		

## PRTS Dynamics - Complete Report

PI Number: Bulletin Number: GM Messenger Date:
<i>Field Remedy:</i>
<i>Production Remedy:</i>

<b>Affected Parts</b>									
<i>VPPS</i>									
1st Level (VPPS): 80-Electrical Function									
2nd Level (VPPS): 80.03-Body Interior & Exterior									
3rd Level (VPPS): 80.03.06-Electronic Body Module									
4th Level (VPPS):									
<i>Part</i>									
Primary Part	Part Number	Part Name	Supplier Name	Part Year	DUNS Code	Catalog Number	Deck Code	Serial Casting Number	
Suspect Parts Available? No									
<i>Shipping Details:</i>									
<i>Location of Parts:</i>									
<i>Remarks:</i>									

<b>Labor Information</b>	
<i>Labor Codes Information</i>	
Primary	Labor Code
Y	N4808

<b>Dealer and Field Contact Information</b>
<i>Dealer</i>
Dealer Number:
Dealer Name:
Dealer Phone:
Dealer Contact:
Dealer Email Address:
<i>Field Representative</i>
Field Rep Contact Name:
Field Rep Number:
Field Rep Phone:
Field Rep Email Address:

<b>Supporting Process</b>
Trigger Question:
Trigger Answer:

## PRTS Dynamics - Complete Report

Step when issue is flagged:  
Flagged by:

Date when issue was flagged:

### Impact Info -> Impacted Product Lines

#### Impacted Product Lines

Product Line	Project Number	Bypass Prioritization	Prioritization Ranking By	Priority Value
STmidtruck	Current 305/360/370	N		

### Impact Info -> Aftersales

#### Aftersales Comments:

#### Aftersales Impact Metrics Information

Metric	Number of Cases

### Customer Satisfaction

#### Customer Satisfaction Question

Product Line	Project Number	Available Data
STmidtruck	Current 305/360/370	No

#### Customer Survey Information

Product Line	Project Number	Impact Category	Survey	Survey Category	Wave	Total PPH	Option PPH	Reference PPH	Satisfaction	Satisfaction Reference	PPH	Model Year

Report Date:

#### Customer Survey Comments

### Warranty

#### Warranty Question

Product Line	Project Number	Available Data
STmidtruck	Current 305/360/370	No

#### Labor Codes Information

Primary	Labor Code
Y	N4808

#### Warranty Measure Information

Product Line	Project Number	Impact Category	Warranty Measure	Sales Region	0 MIS	2 MIS	6MIS	12 MIS	24 MIS	36 MIS	Model Year	Calendar Year	Currency Type	Report Date

#### Solution Effectiveness (%) Information

Product Line	Project Number	Solution Effectiveness (%)

Report Date:

#### Warranty Comment

### Issue Status

#### Issue Status

## *PRTS Dynamics - Complete Report*

<b>Next Step</b>				
<b><i>Next Step Role Assignments</i></b>				
Role Name	Assignment Date	Name	Department	Phone
Champion	22-OCT-2003	Donald Sherman	UNKNOWN ORG	
<b><i>Next Step Target Dates</i></b>				
Next Step Target Submit Date:		Next Step Target Approve/Close Date: 21-NOV-2003		

## PRTS Dynamics - Complete Report

### SOLUTION FEEDBACK

Main					
<i>User Role Assignments</i>					
Role	Assignment Date	Name	Department	Phone	
Champion	22-OCT-2003	Donald Sherman	UNKNOWN ORG		
<i>Step Dates</i>					
Step Start Date	Target Submit Date	Actual Submit Date	Target Close Date	Actual Close Date	
22-OCT-2003		22-OCT-2003	21-NOV-2003	22-OCT-2003	
<i>Step Actions</i>					
Action	Date	Name	Department	Phone	Comment
Submitted	22-OCT-2003	Melissa Clifford	UNKNOWN ORG	+1 586 947 3475 No V	Submitted by migration
Approved	22-OCT-2003	Melissa Clifford	UNKNOWN ORG	+1 586 947 3475 No V	Approved by migration

### Solution Analysis

#### *Last Break Point*

Date	VIN/Part Number	Comment

### Develop Solution

#### *General Answer/Comment:*

VSSMBB article-----

Loss of Daytime Running Lights Disable Feature after BCM Replacement

All 2002 Chevrolet TrailBlazer, Trailblazer EXT, GMC Envoy, Envoy XL, and Oldsmobile Bravada

Susan Anderson: 586-575-8260

Some customers may mention they are unable to disable the DRL feature when following the procedure in the owner's manual. This condition may be present after having a BCM replaced during a previous service visit. In the 2002 models, DRL is disabled by pressing the dome override button four times within six seconds with the ignition in the run position. A chime sounds to confirm the system is off.

After replacing the BCM with new part number #15065293 the system will function as designed for the 2003 model year which has a 4 position headlight switch including a DRL disable position. Due to additional wiring harness changes between 2002 and 2003 models, the 4-position switch will not correct the DRL disable feature on 2002 models. Do not attempt to change the headlamp switch.

A calibration to restore the DRL disable feature is currently in process and a Service Bulletin will be released to inform you when it is available.

#### *Short Description:*

## ***PRTS Dynamics - Complete Report***

VSSMBB - 3/13/2003  
TAC PI - 3/13/2003  
DLRVME 3/13/2003

### ***Field Service Information***

PI Number:  
Bulletin Number:  
GM Messenger Date:

### ***Field Remedy:***

### ***Production Remedy:***

Solution Result:

### **Summary**

*Summary*

### **Supporting Process**

Trigger Question:  
Step when issue is flagged:  
Flagged by:

Trigger Answer:  
Date when issue was flagged:

### **Issue Status**

*Issue Status*

**Complete Report****FPR No: 0812/2003/US****GM Aftersales**Type: **GMNA Truck (US)**

Status:

Country / Region:

Champion:

**Closed** (in time)

US / GMNA

Donald B Sherman

PRTS No.:

FPRD No:

**TrailBlazer - BCM Software - Interior - DRL disable after BCM replacement\*****Affected Vehicles**

Main Carline: TrailBlazer	Other Potentially Affected Carlines: Bravada, Envoy, Envoy XL, Trailblazer EXT	Model Year: 2-02	Model:		
Engine:	Transmission:	Axle:	Transfer Case:		
Local Component FPR: No	Options:	Steering: LHD	No of Cases: 1		
Samples	VIN	Build Date	Engine No	Mileage (km)	Transm. No.
Youngest	1GNDS13S122 [REDACTED]				
Between					
Oldest					

**Problem Description**

Functional Group Level 1: 8 Electrical Function	Level 2: 3 Body Interior & Exterior	Level 3: 6 Electronic Body Modules	Level 4: 02 Personalization FR
--	--	--	--------------------------------------

Trouble Category: E - Electrics - Consuming Devices	Trouble: Mal Function		
Primary Labor Code N4808	Trouble Codes Affected:	Driving Condition:	Environment Condition:
2nd Labor Code	3rd Labor Code	4th Labor Code	5th Labor Code

**Symptoms / Complaints:**

After replacing the BCM (using the VCI #) in an 02 Trailblazer, the ability to disable DRL & auto headlamps is lost. See TAC case # [REDACTED]

**Probable Cause:**

Newer software used in the BCM currently does not allow the disable function.

Corrective Action: Daytime Running Lamp Feature Cannot Be Disabled After BCM Replacement (Update BCM Software) #03-08-42-010 - (09/11/2003)	Success of Corrective Action: Remark: 100%
--	---

**Attachment:****Affected Parts**

Part No:	(Catalog No only valid if OPEL report) Catalog No:	Parts name:	Sample Parts Available:  No
Shipping details:	Remark/ Location of Parts:		

Deck Code:

Serial No. / Casting No. / Component Date Code:

**Severity / Requested Action**

Severity: Action requested:  
4 - Annoyance Field Remedy

**Originator Information**

Originator: NSC:  
Susan M. Anderson USA

**Dealer and Field Contact Information**

Dealer Name: Dealer Number: Dealer Phone:

Dealer Contact Name: Dealer E-Mail Address:

Field Rep Contact Name: Field Rep. Number: Field Rep. Phone:

Field Rep. E-Mail Address:

**Champion Assignment**

Champion: Department: Location:  
Donald B Sherman Vehicle Sales Service & Marketing (VSSM)

E-Mail: Phone: Fax:  
Donald B Sherman/US/GM/GMC@GM

**Champion Designee Assignment**

Champion: Department: Location:

E-Mail: Phone: Fax:

**Visibility**

Access:  restricted  public

**Document Information**

Document created by: Susan M. Anderson/US/GM/GMC 03/11/2003 11:34:13 AM  
Last Modified by: Donald B Sherman/US/GM/GMC 10/07/2003 02:40:34 PM

**Solution**

GM Aftersales

**FPR No:** 0812/2003/US

Type:GMNA Truck

Status:

Closed (in time)

Country/Region:

US/GMNA

Champion:

Donald B Sherman

PRTS No.:

**TrailBlazer - BCM Software - Interior - DRL disable after BCM replacement\***

Affected Carlines:

**Solution Status**Release Status of Solution:  released  not released  refused**General Answer/Comment**

VSSMBB article-----

**Loss of Daytime Running Lights Disable Feature after BCM Replacement**

All 2002 Chevrolet TrailBlazer, Trailblazer EXT, GMC Envoy, Envoy XL, and Oldsmobile Bravada  
Susan Anderson 586-575-8260

Some customers may mention they are unable to disable the DRL feature when following the procedure in the owner's manual. This condition may be present after having a BCM replaced during a previous service visit. In the 2002 models, DRL is disabled by pressing the dome override button four times within six seconds with the ignition in the run position. A chime sounds to confirm the system is off.

After replacing the BCM with new part number #15065293 the system will function as designed for the 2003 model year which has a 4 position headlight switch including a DRL disable position. Due to additional wiring harness changes between 2002 and 2003 models, the 4-position switch will not correct the DRL disable feature on 2002 models. Do not attempt to change the headlamp switch.

A calibration to restore the DRL disable feature is currently in process and a Service Bulletin will be released to inform you when it is available.

**Short Description**

VSSMBB - 3/13/2003

TAC PI - 3/13/2003

DLRVME 3/13/2003

**Field Remedy****Production Remedy**

VIN-Breakpoints:

Breakpoint Date:

**Solution Result**

**PDT**

**Attachments**

**NSC Agreement**

Date	NSC	Refused By	Reason

**Document Information**

Last Modified by: Melissa Clifford/C/US/GM/GMC 10/22/2003 02:45:55 PM

**Communication**

GM Aftersales

**FPR No:** 0812/2003/US**Type:**GMNA Truck**Status:**

Closed (in time)

**Country/Region:**

US/GMNA

**Champion:**

Donald B Sherman

**PRTS No.:****TrailBlazer - BCM Software - Interior - DRL disable after BCM replacement\*****Messages**

Message	From	To	Date
01. Bulletin request	Susan M. Anderson	Frank J. Flees	05/30/2003
02. Daytime Running Lamp Feature Cannot Be Disable	03-08-42-010 - (09/1	Donald B Sherman	

**Document Information****Last Modified by:**

Melissa Clifford/C/US/GM/GMC

10/29/2007 12:49:14 PM

**Status**

GM Aftersales

**FPR No:** 0812/2003/US

Type: GMNA Truck

Status:

Closed (in time)

Country/Region:

US/GMNA

Champion:

Donald B Sherman

PRTS No.:

**TrailBlazer - BCM Software - Interior - DRL disable after BCM replacement\*****Status**

Status

Under Creation

Target Date

n/a

Status Date

03/11/2003

Name

Susan M. Anderson

Result

n/a

Sent

n/a

03/11/2003

Susan M. Anderson

n/a

Additional Info Needed

06/10/2003

05/27/2003

Donald B Sherman

in time

Open

06/26/2003

10/07/2003

Donald B Sherman

late 103 d

Waiting for Release

10/10/2003

10/22/2003

Melissa  
Clifford/C/US/GM/  
GMC

late 12 d

Feedback

11/21/2003

10/22/2003

Melissa Clifford

in time

**Closed**

Date Closed: 10/22/2003

Comment for status:

**PRTS Link****PRTS-Problemnumber:**

PRTS-Subject:

Number:

PRTS-Status:

PRTS - Target:

Champion:

Department:

**Document Information**

Last Modified by:

Melissa Clifford/C/US/GM/GMC

10/22/2003 02:46:00 PM

**Impact**  
GM Aftersales

**FPR No: 0812/2003/US**

Type: GMNA Truck

Status:  
Closed (in time)

Country/Region:  
US/GMNA

Champion:  
Donald B Sherman

PRTS No.:

**TrailBlazer - BCM Software - Interior - DRL disable after BCM replacement\***

**Supplier Information**

Supplier:

DUNS Code:

**Assessment of customer satisfaction impact**

Marketing Division / Vehicle Line	Customer Survey:			Customer Survey:		
	PPH	MY	Wave	PPH	MY	Wave

Report Date:

Customer Survey Specialist:

Customer Survey Comments:

**Assessment of impact on warranty**

Sales Region:

Marketing Division / Vehicle Line	Months in service						Model Year
	0	2	6	12	24	36	
Marketing Division / Vehicle Line	0	2	6	12	24	36	
PTV	0	0	0	0	0	0	
IP	0	0	0	0	0	0	

T V							
I P T V	0	0	0	0	0	0	
I P T V	0	0	0	0	0	0	
I P T V	0	0	0	0	0	0	
C o s t / V e h i c l e	0	0	0	0	0	0	
C o s t / V e h i c l e	0	0	0	0	0	0	
C o s t / V e h i c l e	0	0	0	0	0	0	
C o s t / V e h i c l e	0	0	0	0	0	0	
C o s t / V e h i c l e	0	0	0	0	0	0	

Solution Effectiveness (%):

Report Date: Warranty Specialist:

Warranty Comments:

**Regional Information**

Description	Value	Description	Value

**Document Information**

Last Modified by: 10/29/2007 12:49:14 PM

**FPI**  
GM Aftersales

**FPR No: 0812/2003/US**  
Type:GMNA Truck

Status: **Closed** (in time) Country/Region: US/GMNA Champion: Donald B Sherman PRTS No.:

**TrailBlazer - BCM Software - Interior - DRL disable after BCM replacement\***

Symptoms: After replacing the BCM (using the VCI #) in an 02 Trailblazer, the ability to disable DRL & auto headlamps is lost. See TAC case #6274902 Cases: 1 Mileage: (km)

**Tasks**

Due Date	Task / Action	Owner	Date Raised	Date Closed

**24 h Field Containment / Diagnostic Advice:**

Not sent yet!

**Document Information**

Last Modified by: 10/29/2007 12:49:14 PM



## Memo

To:

cc:

From:

Donald B Sherman/US/GM/GMC

10/07/2003 02:39:32 PM

Daytime Running Lamp Feature Cannot Be Disabled After BCM Replacement (Update BCM Software) #03-08-42-010 - (09/11/2003)

[<- Back](#) [Forward ->](#)

Document ID# 1380970

[Print](#)

---

# Daytime Running Lamp Feature Cannot Be Disabled After BCM Replacement (Update BCM Software) #03-08-42-010 - (09/11/2003)

Daytime Running Lamp Feature Cannot Be Disabled After BCM Replacement (Update BCM Software)

2002 Chevrolet TrailBlazer, TrailBlazer EXT

2002 GMC Envoy, Envoy XL

2002 Oldsmobile Bravada

### Condition

### **Important**

'GM of Canada' Dealers are not authorized to utilize this service bulletin.

Some customers may comment that they cannot disable the Daytime Running Lamps (DRL) feature after following the procedure in the Owner's Manual. This condition may be present after having a Body Control Module (BCM) replaced during a previous service visit. The DRL is disabled in 2002 vehicles by pressing the dome lamp override button four times within six seconds with the ignition switch in the RUN position. A chime sounds to confirm that the DRL system is turned off.

### Cause

The DRL system will function as designed for the 2003 model year after a BCM replacement. The headlight switch on 2003 model year vehicles has four positions with a DRL disable position. Due to wiring harness changes between 2002 and 2003 vehicles, the four position switch will not correct the DRL disable feature on 2002 vehicles. Do not replace the headlamp switch to correct this concern.

### Correction

Reprogram the BCM with updated calibrations to restore the DRL disable feature. The new calibrations will be available in TIS Version 9.5, scheduled for release on September 7, 2003. The calibrations are electronic calibrations and are NOT available from GMSPO.

### Warranty Information

For vehicles repaired under warranty, use:

Labor Operation	Description	Labor Time
N4808	Body Control Module-Reprogram	0.4 hr

GM bulletins are intended for use by professional technicians, NOT a "do-it-yourselfer". They are written to inform these technicians of conditions that may occur on some vehicles, or to provide information that could assist in the proper service of a vehicle. Properly trained technicians have the equipment, tools, safety instructions, and know-how to do a job properly and safely. If a condition is described, DO NOT assume that the bulletin applies to your vehicle, or that your vehicle will have that condition. See your GM dealer for information on whether your vehicle may benefit from the information.



WE SUPPORT  
VOLUNTARY  
TECHNICIAN  
CERTIFICATION

© Copyright General Motors Corporation. All Rights Reserved.

<- Back Forward ->

Document ID# 1380970

Print



# Memo

Sent on 05/30/2003 09:47:03 AM

**To:** Frank J. Flees/US/GM/GMC@GM, Edward P Laskowski/C/US/GM/GMC@GM  
Susan M. Anderson/US/GM/GMC  
05/30/2003 09:47:03 AM  
Bulletin request

**FPR No:** 0812/2003/US TrailBlazer - BCM Software - Interior - DRL disable after BCM replacement\*

Please process the attached bulletin request.....



SICT DRL Disable after BCM.DO

---

This memo was generated in FIND. You can do the following:

[Open Problem](#)

[Open FIND for Reply](#)

[Register FIND](#)

# SERVICE INFORMATION COMMUNICATION TEMPLATE

(Please refer to instruction sheet)

Date/Revision: 05/30/03 Issue/Concern: No ability to disable DRL  
FIND FPR # 24 Hour Case # File Name:  
Template Author: [REDACTED]  
Position: BQM Phone Number: 586-575-8260 VME Node: [REDACTED]

Type of Communication: (Check all that apply)

PI: [Click Here](#) [Click Here](#) [Click Here](#)  
(PI# )

Bulletin: New [Click Here](#) VME: [Click here](#)

Other:  Techlink Article  IDL  VSSM Library  Admin Msg  Talking Paper

Is FPE or legal approval required? (i.e., safety, emissions, compliance):  Yes  No

Divisions: (Check all that apply)

Chevrolet  Pontiac  Oldsmobile  Buick  Cadillac  GMC  Saturn  Isuzu  HUMMER

Model Year (s): 2002

Model(s) Involved: TrailBlazer, TrailBlazer EXT, Envoy, Envoy XL, Bravada

Specific Options/RPO Codes Involved: N/A

**Subject/Title: Unable to Disable Daytime Running Lamps after BCM rplacement**

**Customer Concern:** Some customers my mention they are unable to disable the DRL feature when following the procedure in the owner's manual. This condition may be present after having a BCM replaced during a previous service visit. In the 2002 models, DRL is disabled by pressing the dome override button four times within six seconds with the ignition in the run position. A chime sounds to confirm the system is off.

**Cause (Required for Bulletin):**

After replacing the BCM with new part number #15065293 the system will function as designed for the 2003 model year which has a 4 position headlight switch including a DRL disable position. Due to additional wiring harness changes between 2002 and 2003 models, the 4-positon switch will not correct the DRL disable feature on 2002 models. Do not attempt to change the headlamp switch

**Recommendation (Required for PI):**

**Correction (Required for Bulletin):** . Reprogram the BCM with new software to restore the disable feature.

Issue Champion: [REDACTED] Phone: [REDACTED] 60 VME Node: 58633-58260

Additional Name(s) for [REDACTED] Phone: 5 [REDACTED] 91 VME Node: 58633-32391

**\*\*\*THIS SECTION IS FOR BULLETIN REQUESTS ONLY\*\*\***

Estimated Total Number of Vehicles Involved: \_\_\_?\_\_\_\_\_

[Click here](#)

Is the Item on CPIT Single Issues List?  Yes  No

If yes, supply PRTS Number:

Is Fix Being Implemented into Production:  Yes  No

EWO Number: AVDBW

Date:

DRE: Alfred Adams 248-753-2983

Has stock disposition been communicated to GMSPO?  Yes  No

Are VIN Breakpoints Involved: Yes No

If yes, supply VIN breakpoints (for all plants)

If VIN breakpoints are unknown, supply contact; Name:

Phone:

Are parts required? Yes No

Old P/N (If applicable):

New P/N:

Parts supplier/contact:

Phone:

Issue Number: 0812/2003/US Issue Age: 225 days Issue Type: (Aftersales) Product Report Issue Status: Closed Actions: Available Issue Actions

Issue Events: 22-Oct-2003 - Approved [Solution Feedback] Current Step: Solution Feedback Current Step Status: Complete Current Step Target:

Project: US-United States Program: TrailBlazer / GMNA Truck

Subject: [REDACTED] Interior - DRL disable after BCM replacement\*

Product Line: STmidtruk-Global Midsize Truck Project Number: Current 305/360/370

Severity: 4-Annoyance / Continuous improvement. [!]

Associated Issues: 0 Tasks: 0 Attachments: 4 Memos: 2

Issue Memos -> View User Memo

Close

From: Susan Anderson

Sent To:

To: Frank J. Flees/US/GM/GMC/GM##Edward P Laskowski/C/US/GM/GMC/GM

cc ...

Memo:

Subject: Bulletin request

Text:

FPR No: [REDACTED] TrailBlazer - BCM Software - Interior - DRL disable after BCM replacement\*

Enter your message here:  
Please process the attached bulletin request.....

This memo was generated in FIND. You can do the following:  
If you can't use the buttons, please register FIND, by pressing this Doc-Link:

Attachment(s):

Action	View/Download Attachment	Attachment Title	File Size(MB)	Associated Step	Attach Date	Attached By
There are no items to display.						

Last Updated By: Susan Anderson Last Updated Date: 30-May-2003

\* indicates required field for this screen

© Copyright 2017 General Motors.

Close

No part of this information may be used without the written consent of General Motors.

February 11, 2002

[REDACTED]  
[REDACTED]  
El Paso, TX [REDACTED]

Request: [REDACTED]

Dear Mr. S [REDACTED]

We are sorry you continue to be dissatisfied with the decision made concerning your 2002 Chevrolet Trailblazer. We know you are sincere in the position you have taken, and hope you also understand our point of view.

General Motors, through the Better Business Bureau (BBB) Autoline, provides a service of mediation/arbitration for its customers regarding the new vehicle warranty. General Motors has committed itself to accept and abide by decisions made in this arbitration process.

The BBB Autoline is available to you at no cost. In certain circumstances, you may be required to use the BBB Autoline prior to participation in other resolution methods. This program is discussed in your vehicle's "Warranty and Owner Assistance Information Booklet."

Please call the Better Business Bureau at 1-800-955-5100 to utilize this service. They will provide you with full details of the program.

Thank you for the opportunity to review this matter.

Sincerely,

Jeanne Reed  
Customer Relationship Manager

MN0001-P/kaw

February 26, 2002

[REDACTED]  
Brunswick, GA 3 [REDACTED]

Request: [REDACTED]

Dear Mr [REDACTED]

Thank you for your recent comments regarding your 2002 Chevrolet Trailblazer. Feedback from customers, such as you, as to your experiences, allows us to improve our products and increase customer satisfaction.

Given that your comments indicated that you have concerns with your vehicle, we tried to call you to discuss how we can help. Unfortunately, we have been unable to reach you at the telephone number listed in our records.

We realize that you may already be working with someone at your dealership or our Chevrolet Customer Assistance Center to resolve your concern. If this is not the case and you have outstanding issues, please feel free to contact us at our Chevrolet Customer Assistance Center at 1-800-222-1020 Monday through Friday between 8:00 a.m. and 11:00 p.m., Eastern Time. Please refer to your request number above and any of our Customer Relationship Managers will be happy to assist you. If you have already contacted the Customer Assistance Center, please disregard this letter.

Chevrolet and your dealer's mutual goal is your total satisfaction with Chevrolet products and services. We look forward to talking with you soon.

Sincerely,

LaKesha Thomas  
Customer Relationship Manager

SU0003-A/bmw

May 10, 2002

[REDACTED]  
Kingston, NY [REDACTED]

Request [REDACTED]

Dear Ms [REDACTED]

We are sorry you continue to be dissatisfied with the decision made concerning your 2002 Chevrolet TrailBlazer. We know you are sincere in the position you have taken, and hope you also understand our point of view.

General Motors, through the Better Business Bureau (BBB) Autoline, provides a service of mediation/arbitration for its customers regarding the new vehicle warranty. General Motors has committed itself to accept and abide by decisions made in this arbitration process.

The BBB Autoline is available to you at no cost. In certain circumstances, you may be required to use the BBB Autoline prior to participation in other resolution methods. This program is discussed in your vehicle's "Warranty and Owner Assistance Information Booklet."

Please call the Better Business Bureau at 1-800-955-5100 to utilize this service. They will provide you with full details of the program.

Thank you for the opportunity to review this matter.

Sincerely,

Richard Perez  
Customer Relationship Manager

MN0001-T/waa