

From: Hall, Christopher (C.) <CHALL48@ford.com>
Sent: Thursday, August 15, 2013 12:04 PM
To: Hall, Christopher (C.) <chall48@ford.com>
Subject: Report Summary for the CQIS Report#DGPHZ002

Attachments : 0

Report# :	DGPHZ002 NHL	Received:	07/16/2013
CCRG/EPRC:		Date:	
Vehicle:	2013,EXPLORER 4X2 (U502) LIMITED,4 DOOR ,MPV ,1FM5K7F88D [REDACTED]	Build Date:	04/18/2013
Odometer :	2.637 M	Engine:	3.5L CYCLO
Transmission:	6F55	Axle:	
Dealer:	USA 04947 Walker Ford Company, Inc.	Calibration:	DUB1SN0A
City:	Clearwater	A/C:	YES
Originator:	TOM TWRIGHT	Phone#:	(727) 535-3673
Symptom:	1 14 2 02 COMF/ENT,INTERIOR ODOR ,CHEMICAL,ALWAYS	Country :	USA
Status:			
VFG:	V74 HARD TRIM/SOFT TRIM/OVERHEAD S		
Additional Symptom:	REPEAT ODOR AFTER TSB 12-12-04		
Fix:	Causal Component :		
Condition Code:			
Hotliner:	AMART521	Phone:	313 317-6313
Engineering:		Regn Cd:	S3 Orlando
Dlr Contact:		TAR:	0-30
		Title Cde:	SF

DTCs:
KOE0:
KOE1:
KOE2:

Comments :

REPAIR 07/16/2013 05:04PM ADAM MARTIN MSS - FCSD - TECH SVC HOTLINE
WEB FORM DATA - CONCERN: EXHAUST SMELL IN CAR MORE WITH REAR A/C
ON DIAGNOSTICS: PREFORMED TSB AND CHECKED TO MAKE SURE VENT IN LEFT
REAR IS CLOSED AFTER BEING REPLACED PARTS REPLACED: NONE TECH
QUESTION: LOOKING FOR INFORMATION

RECOMM 07/16/2013 05:04PM ADAM MARTIN MSS - FCSD - TECH SVC HOTLINE
TOM, REPEAT CONCERNS AFTER
HREF='HTTP://WWW.FORDTECHSERVICE.DEALERCONNECTION.COM/VDIRS/SPUBS/ANUM
Q.ASP?FLAVOR=DEALERS&SZARTICLE=12-12-4' TARGET='_BLANK'>TSB 12-12-4
ARE MOST OFTEN CAUSED BY NOT USING ENOUGH SEAM SEALER OR
UNDERCOATING SPRAY. PLEASE ENSURE THAT GENEROUS AMOUNTS OF EACH WERE
USED PER THE TSB. PLEASE ALSO VERIFY PROPER BODY SEALING AS OUTLINED

IN SECTION 501-00 > DIAGNOSIS AND TESTING. IF NONE OF THE SYMPTOMS LISTED IN THAT SECTION ARE RELEVANT, PLEASE INSPECT FOR DAMAGE OR IMPROPER SEALING AT THE AIR EXTRACTORS AND STEERING COLUMN SHAFT BOOT SEAL. BODY DAMAGE CAN ALSO CAUSE THIS CONCERN SO PLEASE ENSURE NONE IS PRESENT AND ENSURE THAT ALL BODY PLUGS ARE PRESENT AND WELL SEATED IN THE FLOOR PAN AND BULKHEAD. PLEASE ALSO INSPECT THE LIFTGATE FOR PROPER SEALING AND PROPERLY SEATED PLUGS IN THE DRAIN HOLES. IF NO ISSUES ARE FOUND, ISOLATE THE SOURCE OF THE LEAK USING THE ROTUNDA 134-R0135 LEAK DETECTOR AND/OR AN ULTRASONIC LEAK DETECTOR. ONCE THE SOURCE IS ISOLATED, REPAIRS SHOULD BE MADE AS NECESSARY. IF THE TSB HAS BEEN COMPLETED CORRECTLY AND NONE OF THE CONCERNS LISTED ABOVE ARE PRESENT, PLEASE BE ADVISED THAT THIS CONCERN IS CURRENTLY UNDER INVESTIGATION. MONITOR OASIS FOR UPDATES./ISM 13-07-010

ADD-ON 08/15/2013 11:56AM CHRIS HALL(FSE) MSS - FCSD - REG ATL-ORLAND-MI
SM CONTACTING FSE BECAUSE CUSTOMER STILL COMPLAINS OF EXHAUST SMELL IN THE VEHICLED WITH AC IN MAX OR RICIRC UNDER HARD ACCELL AND TSB WAS DONE ON FIRST REPAIR AND MORE SEALER AND UNDERCOATING ON THE SECOND REPAIR AND THE SM IS TRYING TO AVOID A LEMON LAW FOR THE THIRD REPAIR.

AUDIT 08/15/2013 11:56AM CHRIS HALL(FSE) MSS - FCSD - REG ATL-ORLAND-MI
TECH ASSIST REFERRAL HAS BEEN OPENED

ADD-ON 08/15/2013 12:03PM CHRIS HALL(FSE) MSS - FCSD - REG ATL-ORLAND-MI
MET CUSTOMER AT DEALER TODAY AND EXPLAINED HOW THE HVAC SYSTEM DRAWS AIR INTO THE VEHICLE IN AC, MAX AC, RICIRC AND EXPLAINED HOW SEALING THE BODY AND INSTALLING ONE AIR RETRACTOR ON ONE SIDE BASICALLY WILL CUT HALF THE SMELL DOWN, BUT NOT 100% AND TO AVOID THE CONCERN UPDER HEAVY THROTTLE THE SYSTEM WILL AHVE TO BE USED IN AC AND NOT IN MAX AC OR RICIRC BECAUSE IN THE LAST TWO POSTIONS THIS IS THE ONLY WAY OUTSIDE AIR CAN BE DRAWN INTO THE VEHICLE. I ROAD TESTED THE VEHICLE WITH THE CUSTOMER AND SHOWED HIM HOW NO SMELL COMES IN IN AC MODE AND DID VERIFY IT DOES COME IN ON MAX AC OR RICIRC. I ADVISED THE CUSTOMER I WOULD INSPECT THE DRIVER SIDE AIR EXTRACTOR TO MAKE SURE THE GLUE WAS HOLDING ON THE TOP ROW AND WHEN I DID THE GLUE IS NOT HOLDING THE RUBBER FLAP SHUT. I ALSO FOUND THE DRAIN FLAP ON THE RIGHT SIDE TAILGATE DRAIN MISSING. I OBTAINED A NEW EXTRACTOR AND USED MOTORCRAFT SILICONE TO GLUE AND COVER THE ENTIR TOP FLAP ON THE BACK SIDE AND WILL ADD THE PICS TO THIS REPORT OF BOTH THE NEW EXTRACTOR GLUED SHUT AND THE OLD ONE HOW THE GLUE IS NOT HOLDING. ONCE THE SILICONE DRIES I WILL INSTALL THE EXTRACTOR AND DRAIN AND RETEST THE VEHICLE. IF THE SMELL IS STILL PRESENT I WILL REMOVE THE ENTIRE REAR BUMPER TO CHECK THE REST OF THE BODY SEALING.

From: CHALL48@ford.com
Sent: Friday, June 22, 2012 2:33 PM
To: Hall, Christopher (C.) <chall48@ford.com>
Subject: Report Summary for the CQIS Report#CEWD8002

Attachments : 9

Report# : CEWD8002 NHL
CCRG/EPRC: **Reviewed Status:**
Vehicle: 2013,EXPLORER 4X2 (U502) XLT 4 DOOR ,MPV ,1FM5K7D90DG [REDACTED]
Odometer : 929 M **Engine:** 2.0L GTDI
Transmission: 6SP 6F MID **Axle:**
Dealer: USA 04947 Walker Ford Company, Inc. **Phone#:** (727) 535-3673
City: Clearwater **State:** Florida **Country :** USA
Originator: GEORGE PFANNSCHMIDT
Symptom: 1 14 2 00 COMF/ENT,INTERIOR ODOR ,CHEMICAL,UNKNOWN
Status:
VFG: V74 HARD TRIM/SOFT TRIM/OVERHEAD S
Additional Symptom: EXHAUST ODOR AFTER HARD ACCEL
Fix:Y **Causal Component :** EXTRACTOR AIR -- RPL
Condition Code:
Hotliner: JSWINDL3 **Phone:** 313 317-9122 **Regn Cd:** S3 Orlando
Engineering: **Phone:** **TAR:** CLD
Dlr Contact: GEORGE PFANNSCHMIDT **Phone:** 727 535-3673 **Title Cde:** T

DTCs:

KOEO:
KOEC:
KOER:

Comments :

REPAIR 05/23/2012 01:12PM JEFF SWINDLEHURST MSS - FCSD - TECH SVC HOTLINE
WEB FORM DATA - CONCERN:AFTER HARD ACCEL THEN CRUISING SPEED HAS
EXHAUST FUMES IN CAR. DIAGNOSTICS: ROAD TEST. PARTS
REPLACED:NONE TECH QUESTION:HOW CAN I STOP THIS????

**RECOMM 05/23/2012 01:12PM JEFF SWINDLEHURST MSS - FCSD - TECH SVC
HOTLINE**

GEORGE, THIS TYPE OF CONCERN IS KNOWN. HOWEVER THIS IS
CURRENTLY
UNDER INVESTIGATION. AT THIS TIME IT IS RECOMMENDED TO MONITOR
OASIS
FOR ANY UPDATES.

ADD-ON 06/06/2012 08:22AM CHRIS HALL(FSE) MSS - FCSD - REG - ORLANDO
OPENING TAR TO DOCUMENT FSE INVOLVEMENT WITH VEHICLE.

AUDIT 06/06/2012 08:22AM CHRIS HALL(FSE) MSS - FCSD - REG - ORLANDO
TECH ASSIST REFERRAL HAS BEEN OPENED

ADD-ON 06/22/2012 02:32PM CHRIS HALL(FSE) MSS - FCSD - REG - ORLANDO
ENGINEERING SENT PARTS AND PROCEDURES TO CORRECT EXHUAST
CONCERN AND
FSE PERFORMED REPAIRS BY HAVING REAR BUMPER REMOVED AND
SEALING REAR
BODY SEAMS WITH 2 PART EPOXY AND SEALING REAR AC LINES TO
CABIN WITH
RUBBERIZED UNDERCOATING AND BY REPLACING BOTH WHEEL WELL
MOLDINGS WITH
UPDATED MOLDINGS AND SEALING BOTH WHEEL WELL BODY SEAMS
AND REPLACING
CABIN VENT ON DRIVER SIDE WITH NEW SPRING LOADED VENTS AND
INSTALLING
SEALS/ONE WAY DRAIN ON REAR LIFTGATE DRAINS.PICS ATTACHED TO
REPORT.

AUDIT 06/22/2012 02:32PM CHRIS HALL(FSE) MSS - FCSD - REG - ORLANDO
TECH ASSIST REFERRAL HAS BEEN CLOSED

Please click on the link below to view the attachments associated with this report
[https://www.gcqis.dealerconnection.com/gcqis/asp/DIViewAttachment_Mainx.asp?
ReportNumber=CEWD8002](https://www.gcqis.dealerconnection.com/gcqis/asp/DIViewAttachment_Mainx.asp?ReportNumber=CEWD8002)

Planet Equipment

Five Gas Emission Analyzer

Model 5G-10

Operator Manual

1215 North Acacia Drive
Gilbert, Arizona 85233

Voice 480-844-1437

Fax 480-844-1457

sales@planet-equipment.com

www.planet-equipment.com

Introduction

Planet Equipment thanks you for your purchase of the 5G-10 Emission Analyzer.

The 5G-10 five gas emission analyzer is accurate, versatile and easy to use. It also has many features. Please read and become familiar with the material in this manual in order to get the best service from your new analyzer. We have provided a Quick Start section for those who would like to start using the 5G-10 immediately.

The 5G-10 was conceived, designed, and proudly built in the United States of America for discerning users worldwide.

Contents

Quick Start	4
Attach Filter Assembly	4
Attach Sample Hose	4
Power Switch	5
Insert Probe into Tailpipe	5
Begin Reading Gas Values	5
Operating Instructions	6
Initial Setup	6
Starting the 5G-10	6
Emission Testing	6
Reading the Display	7
Shutting Down	7
Power Options	7
Battery Charging	8
Keypad	8
Menu System	9
Saving Records	9
Viewing Records	10
Printing Records	11
Deleting Records	11
Recording Live Readings	11
Viewing Recorded Live Data	12
Zero Bench	12
Toggle Automatic Zero	12
Display Backlighting	12
Oil Temperature	12
Engine RPM	13
Battery Level	13
Utilities Menu	13

Calibration Gas Pressure Warning	14
Calibration Check with Gases	14
Gas Calibration with Gases	14
Operator Name	15
New Password	16
Network to PC	16
Maintenance	17
Filter Assembly	17
General Cleaning	18
Support	18
Parts and Accessories	19
Filter Assembly	19
Exhaust Hose and Probe	20
RPM and Oil Temperature Probes	21
Adapters and Harnesses	22
Calibration Fixture and Gas	23
Printer and Battery	23
Specifications	24
Notes	27

Quick Start

Attach Filter Assembly

The filter assembly must be attached to the analyzer before operation. See figure 1.

Analyzer Rear View

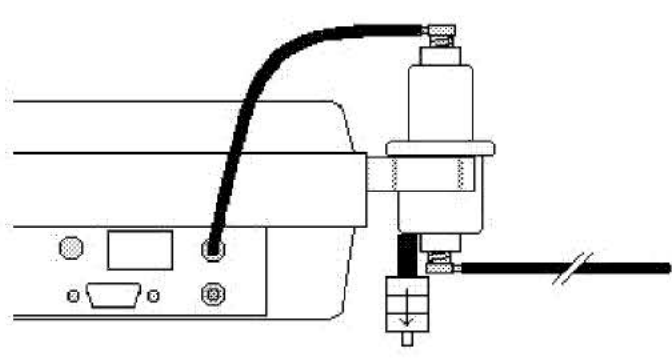

Figure 1

Connect the hose from the UPPER hose barb fitting on the rear panel of the analyzer to the UPPER hose barb fitting fitting on the filter housing. The water drain check valve must also be in place on the filter bowl housing.

Attach Sample Hose

Attach the sample hose from the exhaust probe to the LOWER fitting on the filter bowl housing.

Power Switch

The power switch is located on the rear panel. Press the switch in the upper position to turn the analyzer on. The center position is off. The lower position turns the internal battery charger on when external power is applied to the DC power connector. See battery charging section for more information.

Insert Exhaust Probe into Tailpipe

Insert the exhaust probe fully into the tailpipe. The tubing coil on the exhaust probe can serve as clamp to attach the probe to the edge of the tailpipe. See Figure 2.

Vehicle Tailpipe

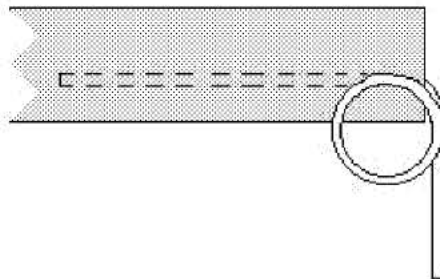

Figure 2

Begin Reading Gas Values

That's it! Begin reading gas values on the display.

Operating Instructions

Initial Setup

Place the filter assembly in the bracket on the side of the analyzer and connect the hoses as shown in Figure 1. The hose on the UPPER hose barb fitting of the filter housing connects to the UPPER (inlet) hose barb fitting on the rear panel of the analyzer. The hose from the exhaust probe connects to the LOWER hose barb fitting on the filter bowl housing. The water drain check valve must be in place on the filter bowl housing.

The LOWER hose barb fitting on the rear panel of the analyzer is the outlet port. A hose is not connected to this fitting unless it is necessary to vent the spent exhaust gases out of an enclosed area, such as when operating inside a vehicle.

Never operate the 5G-10 without a properly functioning filter system. Do not attempt to bypass the filter assembly by connecting the exhaust sample hose directly to the inlet port on the rear panel. Damage caused by contamination is not a warranty matter and will not be covered under the warranty.

Starting the 5G-10

The rocker switch on the rear panel is a three position switch. The upper position is ON. The center position is OFF. The lower position is CHARGE. Press the switch in the upper position to turn the 5G-10 on. The analyzer will perform a self test and will zero itself. It will be ready for operation in approximately 40 seconds.

Emission Testing

When the 5G-10 has completed its initialization routine, the gas reading screen will appear on the display. Insert the exhaust probe into the vehicle tailpipe to obtain exhaust emission readings.

Reading the Display

Gas values and other data will be displayed numerically. At times, some of the values may appear as "xx". This can occur when the values are not within a predetermined range. Please see figure 3.

HC	0	CO	.00
O2	21.33	NOx	0
CO2	.00	RPM	xx
LDA	xx	A/F	xx

Figure 3

HC and NOx are displayed in parts per million (ppm). CO, O2, and CO2 are displayed in percentage (%).

Shutting Down

When vehicle testing is completed, allow the analyzer to run long enough to clear any residual gases or moisture. Press the switch on the rear panel to the center position.

Power Options

The primary source of power for the 5G-10 is its own internal battery. The 5G-10 can also be powered by the supplied AC wall adapter. The adapter will be either a 120VAC or 240VAC wall adapter, depending on the country of use. If yours is a 240VAC adapter, you may have to provide a conversion plug for your area.

The 5G-10 can be powered from the 12VDC battery of the vehicle in test or another 12VDC battery. A DC harness is provided that will connect directly to a vehicle battery, or plug into a vehicle cigarette lighter socket. The DC harness plug or the AC wall adapter plug connects to the 12VDC power jack on the rear panel of the analyzer.

Caution: Observe the correct polarity when connecting to an external battery. The RED clip is POSITIVE. The BLACK clip is NEGATIVE. Use only the wall adapter supplied with the 5G-10. Other adapters can damage the analyzer.

Battery Charging

A message will be displayed when the internal battery needs to be recharged. *Allowing the battery to discharge below this level can cause damage.* When the low battery message appears, recharge the battery. If you need to continue operating the 5G-10, connect an external 12VDC power source to the DC power jack on the rear panel. This can be a vehicle battery or the AC wall adapter.

Please note: The battery does not charge while the analyzer is operating. To charge the battery, supply external power to the DC power jack on the rear panel. Press the rocker switch to its lower position. A discharged battery will charge in 10 to 14 hours. The battery does not need to be completely discharged before recharging.

Keypad

There are six keys on the keypad. They are **MENU**, **ENTER**, and four directional cursor control keys. Please see figure 4. Depending on the current function of the analyzer, not all keys may be operational at all times.

Figure 4

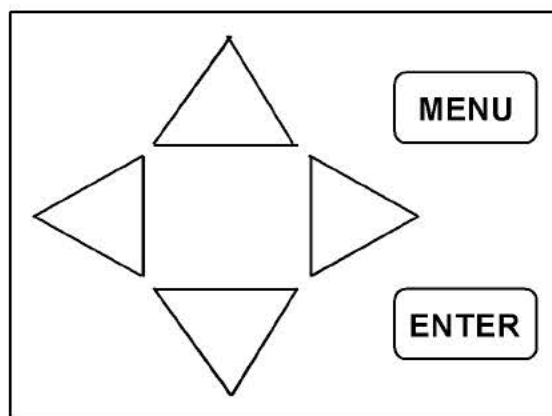

Menu System

The many features of the 5G-10 are available by an easy to use menu system. The menu can be accessed whenever the the gas reading screen is being displayed.

Press the **MENU** key on the keypad until a beep is heard. The menu selections will be displayed.

Scroll up or down through the menu selections using the up/down cursor control keys. An arrow on the display will indicate if there are additional menu choices above or below the currently displayed portion of the menu. When the menu item you wish to select is indicated, press the **ENTER** key. Please see figure 5.

0	Exit MAIN Menu
1	Memory Menu
2	Utilities Menu
3 ↓	Zero Bench

Figure 5

Note that in figure 5 the cursor is on menu selection one, **Memory Menu**. To exit from a menu, scroll up to selection "0" which is always the uppermost line in the menu, then press the **ENTER** key.

Saving Records

Gas readings that are currently on the display screen can be recorded. To save the current readings, press the **ENTER** key when the gas readings you wish to record are being displayed. The readings are recorded the moment the **ENTER** key is pressed.

Another screen will appear that will allow you to add an identification to the record. The ID can be a customer name, license number, VIN number, etc. To make an entry, scroll with the cursor control keys to the number or letter you wish to select. When the cursor is over the selection, press **ENTER**. Up to 20 letters, numbers, or spaces can be entered in any combination. If you make a

mistake, select the back space arrow (the arrow pointing to the left) and press **ENTER**. The last character that was selected will be erased.

When the ID is complete, press the down cursor key until the cursor is on the bottom line of the display. Scroll left or right to either **Print**, **Save**, or **Exit**. Press **ENTER** when the arrow indicates your choice. *It is not necessary to enter an ID in order to save a record.*

Selecting **Print** from this screen will print the data without saving the record to memory. Please note: **Print** is functional only if the optional printer is attached to the analyzer. *If you attempt to print without the printer attached, the analyzer will have to be restarted.*

Save retains the record in memory. Up to 250 individual records can be saved.

Exit returns to normal operation without saving the record.

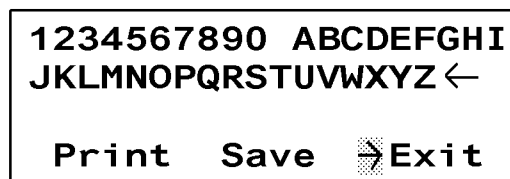

Figure 6

Viewing Records

Access the Main Menu by pressing the **MENU** key until the beep is heard. Scroll to the **Memory Menu** selection. Press **ENTER**. The **Memory Menu** will appear. Select **Recall Records**. If there are no records to display, the message "Memory Empty" will be displayed. Otherwise, the record number and ID (if available) will be shown. Select **View** to see the saved readings. Note that when viewing a record from memory, an asterisk will appear in the top middle of the screen. This indicates that you are viewing previously recorded information. Please see figure 7.

HC	215*	CO	1.24
O2	3.15	NOx	277
CO2	11.08	RPM	755
LDA	1.101	A/F	14.31

Figure 7

Printing Records

To print individual records, access the record as described in the previous section (Viewing Records). When the appropriate record is accessed, press **Print**.

To print all of the records retained in memory, select **Memory Menu** from the **Main Menu**. From the **Memory Menu**, select **Print Records**. The records will be printed in numerical sequence.

It is essential that the printer be connected before selecting any print functions.

Deleting Records

To delete records from memory, select **Memory Menu** from the **Main Menu**. From the **Memory Menu**, select **Delete Records**. This selection deletes all of the individual records from memory.

Recording Live Readings

Select **Memory Menu** from the **Main Menu**. From the **Memory Menu**, select **Record Live Data**. Live readings will be recorded until a key is pressed. a live reading of up to approximately 1/2 hour can be recorded. Only one live reading can be stored at a time. Each new live recording will erase the previous live recording.

Viewing Recorded Live Data

Select **Memory Menu** from the **Main Menu**. From the **Memory Menu**, select **View Live Data**. When viewing recorded data, an asterisk will appear at the top middle of the screen. The recorded data will play back as it was recorded. When completed, the word "Finished" will display and the analyzer will then revert to normal operation. Please see figure 7.

Zero Bench

The analyzer will zero itself when initially turned on. It will also zero itself periodically. The bench can also be zeroed manually. Select **Zero Bench** from the **Main Menu**. The bench will perform a zero routine then return to normal operation.

Toggle Automatic Zero

There may be times that you may wish to disable the automatic zero function. To do this, select **Toggle Auto Zero** from the **Main Menu**. The bench will not zero unless another function is selected that causes it to zero. To re-enable automatic zeroing, select **Toggle Auto Zero** again. Each time **Toggle Auto Zero** is selected, automatic zeroing reverts to its previous state.

Display Backlighting

To turn the display backlight on, select **Backlight** from the **Main Menu**. To turn the backlight off, select **Backlight** again. Each time **Backlight** is selected, the backlight reverts to its previous state.

Oil Temperature

To measure engine oil temperature, remove the engine oil dipstick. Measure the length of the dipstick that is inserted into the dipstick tube. Set the stop on the 5G-10 temperature probe to the length measured. Insert the temperature probe into the dipstick tube the proper distance. Select **Temperature** from the

Main Menu. The engine oil temperature will be displayed in both Celsius and Fahrenheit.

Engine RPM

Clamp the inductive RPM pickup around any spark plug wire. RPM will be displayed on the gas reading screen. In some cases it may be necessary to move the clamp on the spark plug wire to obtain a proper reading or turn the clamp over. On two cycle engines and some DIS vehicles, it may be necessary to select **DIS/2Cycle** from the **Main Menu**. It is possible on these vehicles for the RPM to read higher than its actual value.

Battery Level

To determine the state of charge of the battery, select **Battery Level** from the **Main Menu**. The battery voltage will be displayed along with a battery status indication. Note that the battery voltage is being monitored under load. A fully charged battery will indicate approximately 12.60 volts. The battery will need to be recharged when the level drops to approximately 10.50 volts.

If the battery test is performed while the analyzer is connected to an external power source, the external power source voltage will be indicated in place of the internal battery voltage.

Utilities Menu

The utilities menu is password protected to prevent unauthorized tampering with the analyzer settings. Select **Utilities Menu** from the **Main Menu**. A password must be entered. The default password is the numeral "1". Place the cursor on the numeral **1** and press **ENTER**. An asterisk will be displayed in the first position of the password area. Move the cursor the bottom row of the display with the down cursor control key. The arrow will automatically point at the **OK**. Press **ENTER**. The **Utilities Menu** will now be displayed.

Note that the password you enter will not actually be displayed. Asterisks will be displayed for any character you enter. This prevents on lookers from seeing your password.

Calibration Gas Pressure Warning

Pressurized calibration gas is used to calibrate the analyzer and to perform calibration checks on the analyzer. *Excessive pressure applied to the analyzer ports will cause severe damage to the analyzer.* Calibration gas must be metered at 800 ml/min to the inlet port of the analyzer. It is strongly recommended that only the Planet Calibration Fixture, part number 5GP-1122 be used when calibrating or checking calibration. It has been designed to deliver the calibration gas to the 5G-10 at the proper pressure and flow.

Calibration Check With Gases

Note: See the Calibration Gas Pressure Warning above before continuing.

This selection allows the calibration of the analyzer to be verified. It does not calibrate the analyzer. Select **Cal Check W/Gas** from the **Utilities Menu**. You will be asked if the gas you are using to check the calibration has propane or hexane as its hydrocarbon element. Use the cursor to point the arrow to the correct gas, then press **Enter**. You have the choice to run the pump or turn it off while checking calibration. Make the desired selection. A screen will be displayed showing the current gas readings.

After the analyzer finishes zeroing, disconnect the hose from the filter assembly at the inlet port of the analyzer. Connect the hose of the 5GP-1122 calibration fixture to the inlet port on the rear panel of the 5G-10. Turn the calibration gas bottle valve on. The gauge pressure should be adjusted to 15psi. *Note: 15psi pressure from any other calibration fixture assembly should NEVER be applied directly to the 5G-10. Severe damage will occur.* Read the gas values on the screen.

Turn off the calibration gas bottle valve and remove the hose from the inlet of the analyzer. Reconnect the hose from the filter assembly. Then press any key to exit the calibration check routine.

Gas Calibration With Gases

Note: See the Calibration Gas Pressure Warning above before continuing.

Select **Gas Calibration** from the **Utilities Menu**. You will be asked to name

the hydrocarbon type of the calibration gas you are using. Next you will be asked the concentration of the gas blends you are using to calibrate with (HC, CO, CO₂, and NO_x). Use the up/down cursor controls to modify the values as necessary. Use the left/right cursor controls to move to the appropriate digit. When the values for the particular gas match those from your gas container, press **ENTER**. Continue using the same procedure until all of the gas values are entered.

The analyzer will zero itself. When the following prompt "Attach hose to inlet; Turn gas on (15psi)" appears, disconnect the hose from the filter assembly at the inlet port on the rear panel. Connect the hose from the calibration fixture to the analyzer inlet port. Turn the calibration gas bottle valve on and adjust the regulator pressure to 15psi.

The calibration will be performed automatically. When it is completed, you will be prompted to turn the gas off and disconnect the hose. Remember to reconnect the hose from the filter assembly to the analyzer inlet port.

If a new NO_x sensor has just been installed, answer **Yes** when prompted. Otherwise, answer **No**. The default is **No**.

Operator Name

An operator identification name can be entered. It will be saved in memory. It will be attached to each record saved. When records are printed, the operator ID will be printed with each record. The operator ID can be the name of the technician, the name of the repair shop or facility, the government inspector identification number, etc.

To enter the operator name, select **Operator Name** from the **Utilities Menu**. Scroll with the cursor control keys to the number or letter you wish to select. When the cursor is over the selection, press **ENTER**. Up to 20 letters, numbers, or spaces can be entered in any combination. If you make a mistake, select the back space arrow (the arrow pointing to the left) and press **ENTER**. The last character that was selected will be erased.

When the operator name entry is complete, press the down cursor key until the cursor is on the bottom line of the display. Use the left/right cursor controls to select **Save** or **Exit**. If you select **Exit**, the ID will not be saved.

New Password

The default password is the numeral "1". It can be changed to any combination of letters and numbers up to 20 characters in length. If you change the password, be sure to remember it (or write it down). If you forget your password, you will not be able to access the **Utilities** menu. The analyzer will have to be returned to the factory to be reconfigured.

Select **New Password** from the **Utilities Menu**. Enter the new password in the same manner as entering the Operator ID as described in the previous section. You will be asked to verify the new password.

Network to PC

This selection allows the 5G-10 to communicate with a PC. Connect an RS232 serial communication cable from the DB9 connector on the rear panel of the 5G-10 to a PC. Select **Network to PC** from the **Main Menu**. Start the Planet 5G-10 PC software program on the PC.

Maintenance

Filter Assembly

Filter Operation

The 5G-10 incorporates a high performance filtration/water removal system. The filter housing contains two filters. The lower filter is a metal mesh screen that removes large particles from the exhaust sample. The upper filter is a fiber element that filters the fine particles from the exhaust sample. The lower metal screen filter can be cleaned with soap and water. The upper fiber filter must be replaced when dirty.

Attached to the lower portion of the filter bowl is a water drain check valve. Any water that accumulates in the lower portion of the filter bowl is emptied automatically via a flow reversal/pressure change controlled by the microprocessor. Please see figure 8.

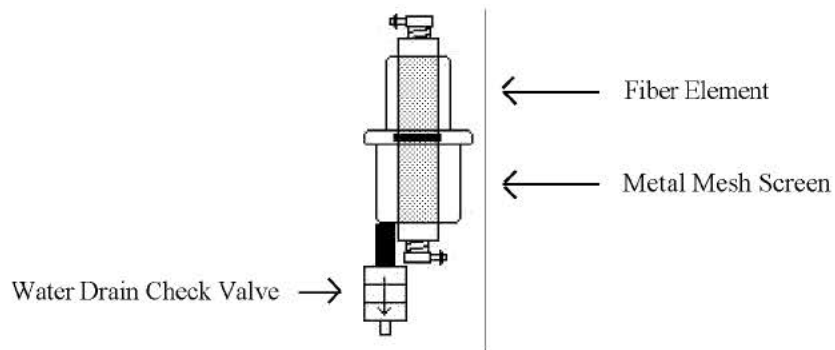

Figure 8

Filter Maintenance

Remove the filter assembly from the analyzer. Disassemble the filter bowl assembly by twisting apart at the center joint. Remove the upper and lower filter elements.

The lower metal screen element can usually be cleaned using soapy water and a small brush. If the screen filter is extremely dirty or restricted, it must be replaced. The upper fiber element must be replaced when dirty.

Verify that the filter bowl gasket and the rubber filter divider are in good condition.

To reassemble, place the rubber filter divider between the fiber and screen filter elements, insert into the filter bowls and twist the filter bowl housings together until they lock.

Check Valve

Verify that the water drain check valve operates properly. It is a one way check valve that must open with very little pressure allowing water to drain from the filter bowl. It must seal against air entering into the filter bowl.

General Cleaning

The case and plastic panels can be cleaned with a damp cloth using mild soap and water. Be sure that liquid is not allowed to enter the interior of the analyzer.

The exhaust sample hose and probe can be removed and blown out with compressed air. This helps to remove any debris or water that may have collected in the hose and probe assembly.

Support

If you have questions concerning your 5G-10, please contact us.

Telephone	480-844-1437
Fax	480-844-1457
E-mail	support@planet-equipment.com.

Parts and Accessories

Filter Assembly

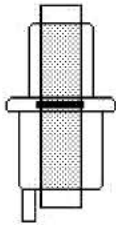

5GP-1014 Filter Assembly (w/o fittings)



5GP-1010 Filter, Secondary (fiber)



5GP-1011 Filter, Primary (metal screen)



5GP-1070 Check Valve, Water Drain



5GP-1012 O-Ring, Filter bowl



5GP-1013 Divider, Filter

Exhaust Hose and Probe

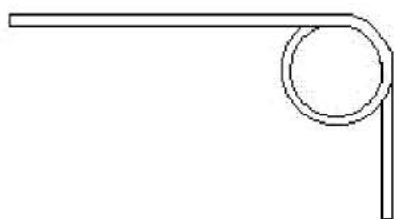

5GP-1095 Exhaust Probe



5GP-1072 Exhaust Hose (Viton)

RPM and Oil Temperature Probes



5GP-1111 RPM Probe



5GP-1123 Oil Temperature Probe

Adapters and Harnesses



5GP-1019 Adapter, 220 VAC

5GP-1020 Adapter, 110 VAC

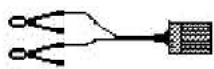

5GP-1112 Harness, DC Battery

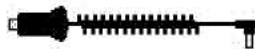

5GP-1114 Harness, Cigarette Lighter

Calibration Fixture and Gas

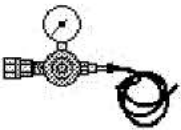

5GP-1122 Calibration Fixture

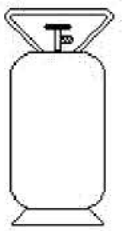

5GP-1125 Calibration Gas

Printer and Battery

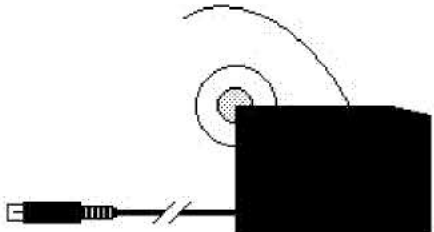

5GP-1120 Printer



5GP-1121 Printer Battery

Specifications

Measurement Method

NDIR (Non-Dispersive Infrared) for HC, CO, CO2
Electrochemical for NO, O2

Program Accuracy Adherence

EPA ASM
ASM/BAR97
OIML Class 0 and OIML Class 1

Gases Measured

HC (Hydrocarbon)
CO (Carbon Monoxide)
CO2 (Carbon Dioxide)
O2 (Oxygen)
NO (Nitric Oxide)

Displayed Data

HC	0-30,000ppm
CO	0-15%
O2	0-20%
NOx	0-5000ppm
O2	0-25%
Lambda	0.200-1.800%
A/F	3:1-30:1
RPM	300-15,000rpm
Temperature	0-302F (0-150C)

Size

10" x 7.5" x 3.5" (26cm x 19cm x 9cm)

5 G - 1 0

Weight

Instrument 7lbs (3.1 kg)

Power Supply

Internal gel cell battery (rechargeable)
External 12 VDC supply (vehicle battery or cigarette lighter)
120 VAC (240 VAC) wall adapter

Battery Operating Time

Up to 6 1/2 hours continuous

Battery Charge Time

10 hours (approximate)

Operating Environment

32 to 122 Degrees Fahrenheit (0 to 50 Celsius)
To 95% Humidity
Minus 1,000 to 8,000 ft (-300 to 2,500 m)

Measurement Resolution

HC: 1 ppm
CO: 0.01%
CO2: 0.01%
O2: 0.01%
NO: 1 ppm

Measurement Accuracy

HC:	0 to 2,000 ppm	+/- 4ppm abs or +/- 3% rel
	2,001 to 15,000	+/- 5% rel
	15,001 to 30,000	+/- 8% rel
CO:	0.00 to 10.00%	+/- 0.02 abs / +/- 3% rel
	10.01 to 15.00%	+/- 5% rel
CO2:	0.00 to 16.00%	+/- 0.3 abs / +/- 3% rel
	16.01 to 20.00%	+/- 5% rel

O2:	0.00 to 25.00%	+/- 0.1% abs / +/- 3% rel
NO:	0 to 4,000 ppm	+/- 25 ppm abs / +/- 3% rel
	4,000 to 5,000 ppm	+/- 5% rel

Sample Acquisition Time

Approximately 6 seconds

Warm Up Time

40 seconds

Memory

Stores up to 250 individual records with ID
Records up to 1/2 hour of live data

PC Communication

RS232 port
5G-10 can be operated from PC
Records can be downloaded to PC

Optional Printer

Operates by AC adapter or optional battery

Specifications and data in this manual are subject to change without notice.

Notes

FORD:

2011-2015 Explorer

This article supersedes TSB 14-04-NA and 14-14-NA to update the service procedure and parts.

ISSUE:

Some 2011-2015 Explorer vehicles may exhibit an exhaust odor in the vehicle while the climate control system is in auto or recirculation mode. This may be more pronounced after hard acceleration, driving in hilly conditions and/or towing a trailer. Customers may indicate the odor smells like sulfur.

NOTE: This procedure should be used only for vehicles which involve a customer complaint of exhaust odor and/or exhaust odor verified through a road test by a Ford trained technician. The odor concern is affected by many factors, including road conditions, driving style, climate, HVAC settings, trailer towing, and the particular customer's sensitivity to odor. Most customers have not complained of this exhaust odor problem. There are trade-offs associated with this TSB procedure, and those trade-offs could lead to complaints of increased noise from exhaust air rush.

ACTION

Follow the Service Procedure steps to correct the condition.

SERVICE PROCEDURE

1. Remove the rear lip moldings (vehicles built prior to February 1, 2013 only) and remove bumper cover. Refer to Workshop Manual (WSM), Section 501-19.
2. Replace the left side rear air extractor. (Figure 1)



Figure 1 - Article 14-16-NA

3. Open the liftgate and install a new drain valve in each of the two (2) drain holes on the left and right side of the liftgate. Apply a slight amount of sealant on the drain valves used in the liftgate drain holes to keep them from coming loose. (Figure 2)

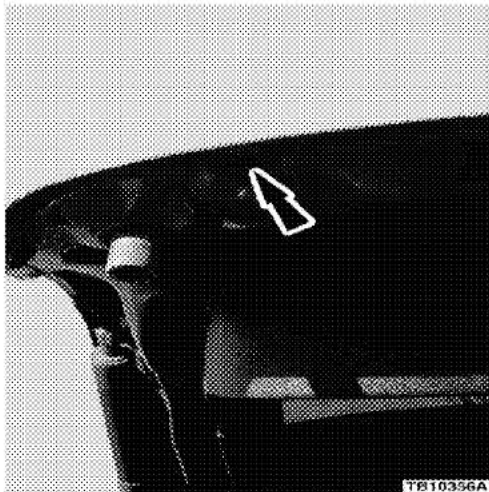

Figure 2 – Article 14-16-NA

- 4. Raise vehicle on hoist. Refer to WSM, Section 100-02.
- 5. Lower and support rear section of the exhaust system.
- 6. Clean areas on underside of vehicle where seam sealer will be applied. (Figures 3-5 below)

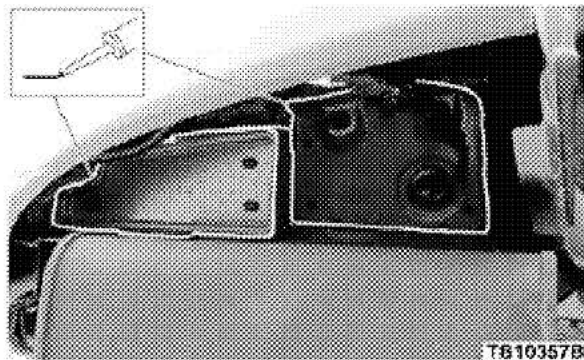

Figure 3 – Article 14-16-NA

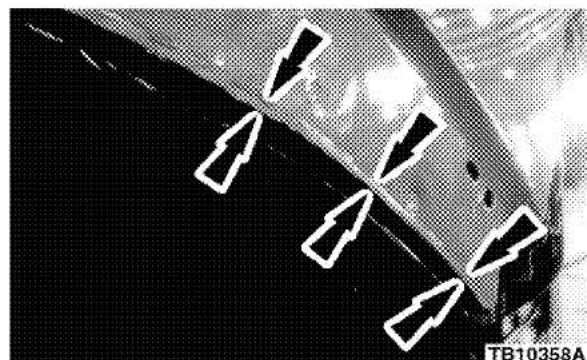

Figure 4 Article – 14-16-NA

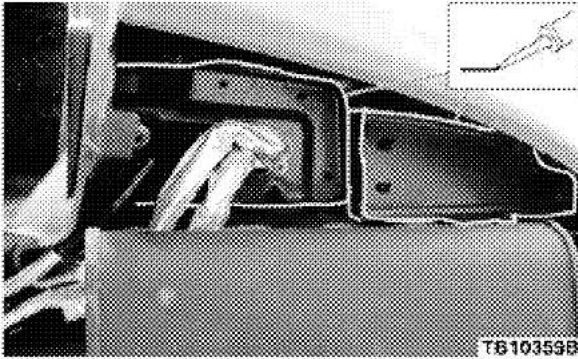

Figure 5 – Article 14-16-NA

7. Cover the exhaust system and auxiliary climate control drain to prevent the seam sealer from getting on these parts or clogging the drain during sealer application.
8. Apply a generous amount of Motorcraft Seam Sealer to rear horizontal sheet metal lap joints on left and right sides of the vehicle, and the rear sheet metal overlap flange across the rear of the vehicle. Make sure the sealant has sealed the openings and remove if any excessive sealant applied. (Figures 3-5 above)
9. Spray generous amount of 3M Rubberized Undercoating around auxiliary air conditioning lines and seam sealer areas. (Figure 6)



Figure 6 – Article 14-16-NA

10. Allow seam sealer to dry. (May take up to 20 minutes)
11. Perform a pressure test and confirm there is no leak in the rear side of the vehicle.

Pressure Test Procedure

- a. Using masking tape, seal the rear air extractors and areas marked in red. Do not need to mask the rear lip molding for vehicle that do not have the rear lip molding removed (Figure 7-8)



Figure 7 – Article 14-16-NA

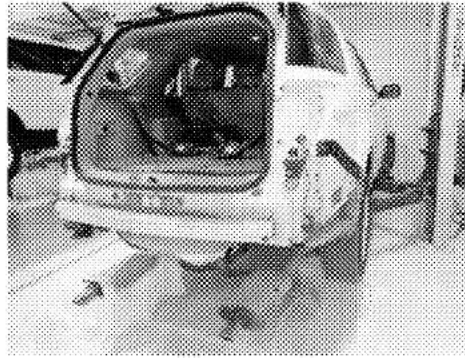

Figure 8 – Article 14-16-NA

- b. Start vehicle, set A/C to fresh air mode and set blower speed to max.
- c. Close all doors and ensure windows are fully closed.
- d. Use soapy water in a spray bottle to help locate air leaks.
- e. Spray around the following areas:
 - ❖ Under body seams
 - ❖ Underbody rubber grommet (Figure 10)
 - ❖ Rear wheel well seams
 - ❖ Rear tail light seams
 - ❖ Rear deck lid seals
 - ❖ Side panel glass seals
 - ❖ License plate area
- f. Air leaks can be identified by the presence of air bubbles.
- g. Mark all areas identified to have air leaks. Common areas shown below. (Figure 9-12)



Figure 9 – Article 14-16-NA

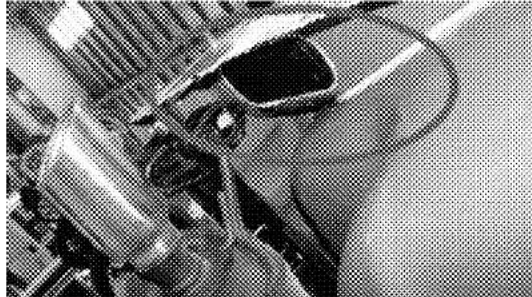

Figure 10 – Article 14-16-NA

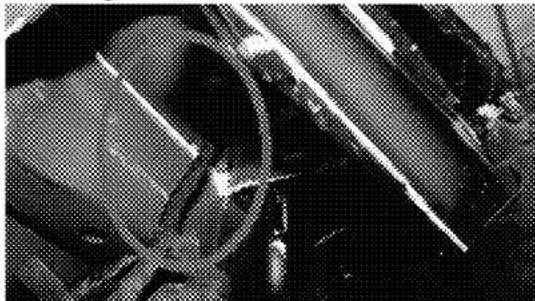

Figure 11 – Article 14-16-NA



Figure 12 – Article 14-16-NA

- h. Turn off A/C
- i. Turn off vehicle
- j. Clean and dry all areas marked earlier
- k. Seal using Motorcraft seam sealer
- l. Allow sealant to dry and retest (May take up to 20 minutes)
- m. Remove the masking tape used in step (a) of the pressure test

12. Spray Wurth Gravel Throw And Underbody Protection over the sealant applied areas for better appearance. (underbody only)

13. Install rear bumper cover. Refer to WSM, Section 501-19.

14. Install the left hand and right hand rear lip moldings. Refer to WSM, Section 501-08. Vehicles built prior to February 1, 2013 replace the wheel lip molding with revised part.

15. Using a suitable exhaust cutting tool, remove the existing tailpipe/tip 5mm (.19 inches) to the rear of the factory weld as shown. Be careful not to cut or damage the exhaust hanger bracket. (Figure 13-14)

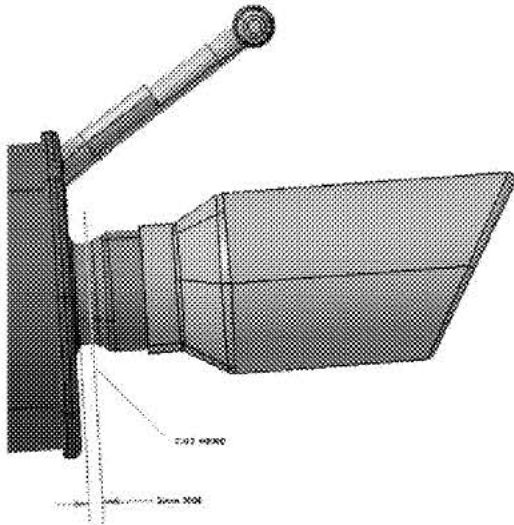

Figure 13 – Article 14-16-NA

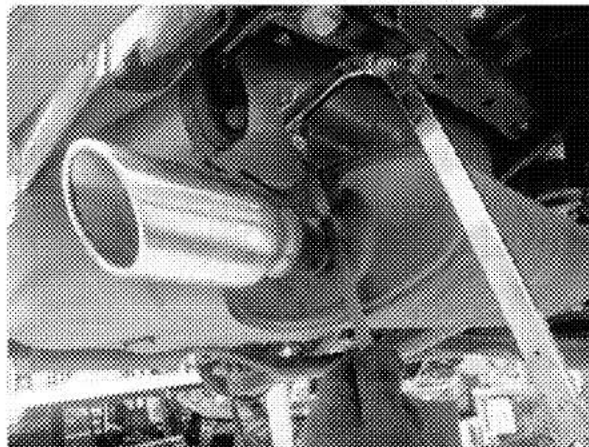

Figure 14 – Article 14-16-NA

16. Remove the existing exhaust tip. Grind down enough of the original weld to remove the rest of the exhaust tip that was left over in the muffler. Remove any remaining sharp edges and/or burrs produced during the cutting process. (Figure 15-16).

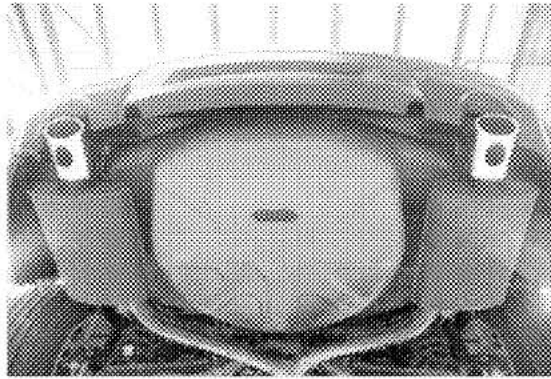

Figure 21 – Article 14-16-NA



Figure 22 – Article 14-16-NA

Obtain Parts Locally	
Part Number	Part Name
08882	3M Rubberized Undercoating
Würth 0892 075 250	Würth Gravel Throw And Underbody Protection

PART NUMBER	PART NAME
Obtain locally sourced part	Exhaust Tip (2 required)
BB5Z-61280B62-B	Dual Rate Air Extractor (1 required)
BB5Z-7829164-AA	Wheel Lip Molding Right Hand (Vehicles built prior to February 1, 2013 only)
BB5Z-7829165-AA	Wheel Lip Molding Left Hand (Vehicles built prior to February 1, 2013 only)
4M8Z-54280B62-A	Valve Assembly Auto Drain
TA-2	Motorcraft Seam sealer

OPERATION	DESCRIPTION	TIME
	2011-2015 Explorer: Seal Body Includes Time To Replace Air Extractors, Replace Both Rear Fender Moldings, and Install Liftgate Drain Valves (Do Not Use With Any Other Labor Operations)	1.9 Hrs.
	2011-2015 Explorer: Perform Pressure Test To Identify And Mark Any Further Leak Areas	0.7 Hrs.
	2011-2015 Explorer: Seal Additional Identified Leak Areas (If Any)	0.2 Hrs.
	2011-2015 Explorer: Install New Exhaust Tip	1.8 Hrs.

Dealer Coding

BASIC PART NO.	CONDITION CODE
54280B62	07

WARRANTY STATUS: Eligible Under Provisions Of New Vehicle Limited Warranty Coverage
 Warranty/ESP coverage limits/policies/prior approvals are not altered by a TSB. Warranty/ESP coverage limits are determined by the identified causal part and verified using the OASIS part coverage tool.

