

EA16-002

FLAT CHRYSLER

5-12-2016

ENCLOSURE 04

CAIR Backup



**Francine Elliott**

---

**From:** John Mingay  
**Sent:** Tuesday, April 15, 2014 11:39 AM  
**To:** Francine Elliott  
**Cc:** Christopher Lupton; Lindsay Denomme  
**Subject:** FW: Chrysler 300 - reverse issue, VIN - CH134991  
**Attachments:** Screen Shot 2014-04-15 at 11.27.16 AM.png

RECEIVED

APR 15 2014

CUSTOMER SERVICE

29S please.

**From:** Madeline McEachern [<mailto:madeline.mceachern@publicis.ca>]  
**Sent:** Tuesday, April 15, 2014 11:37 AM  
**To:** Dana Oglan; John Mingay  
**Cc:** Samantha Parici; [laurie.freeman@publicis.ca](mailto:laurie.freeman@publicis.ca)  
**Subject:** Chrysler 300 - reverse issue

Hi Dana,

This customer posted on Chryslers FB. She's already spoken to your team and provided a ref # but I want to pass along anyway.

Thanks – let me know if there are any concerns.

Maddie

Madeline McEachern

Junior Community Manager | Account Coordinator

Publicis Canada | 1 Riverside Drive West

Windsor Ontario, N9A 5K3 | Canada

1-519-252-9479 Ext. 18210 (office) | 1-519-551-2321 (cell)

[madeline.mceachern@publicis.ca](mailto:madeline.mceachern@publicis.ca)

---

Disclaimer The information in this email and any attachments may contain proprietary and confidential information that is intended for the addressee(s) only. If you are not the intended recipient, you are hereby notified that any disclosure, copying, distribution, retention or use of the contents of this information is prohibited. When addressed to our clients or vendors, any

information contained in this e-mail or any attachments is subject to the terms and conditions in any governing contract. If you have received this e-mail in error, please immediately contact the sender and delete the e-mail.



My husband and I have been loyal Chrysler owners for most of our adult lives. I own a 2012 Chrysler 300. I have noticed that on occasion when put in to park it starts to reverse so immediately that can be rectified because as soon as you open the door it reverses. To my horror I parked the car on the main street of our town , put it into park and pressed the button to turn it off. I exited the vehicle and went into the shopping mall. The car reversed after a minute or two aft...

See More

Like · Comment · about an hour ago



Write a comment...



**Chrysler Canada** Hi [redacted] that must have been scary and we are glad to hear you're okay. Could you please email your VIN#, daytime phone number and dealer name to: [welisten@chryslercanada.ca](mailto:welisten@chryslercanada.ca)? We'll have Customer Care contact you. Thank you.

Like · Reply · 34 minutes ago



[redacted] Thank you - I have already spoken to customer care - the case # is [redacted]. I post this only so others will be aware of this safety problem and be super vigilant so that this does not occur to anyone else.

Like · 2 minutes ago



Write a reply...

EA16-002

FLAT CHRYSLER

5-12-2016

ENCLOSURE 04

CAIR Backup

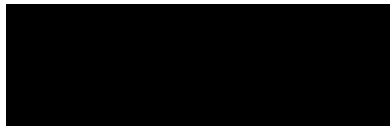

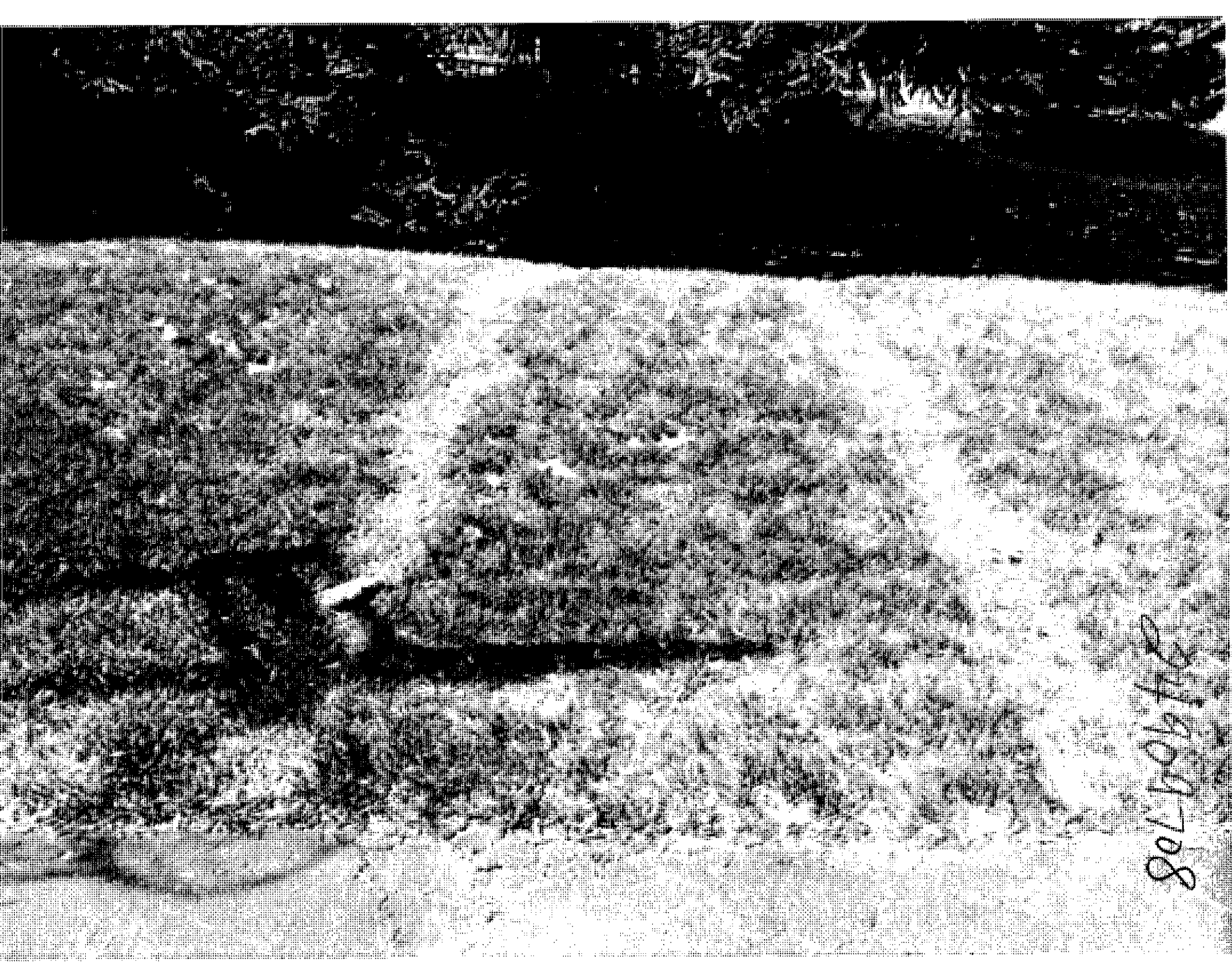

214904708



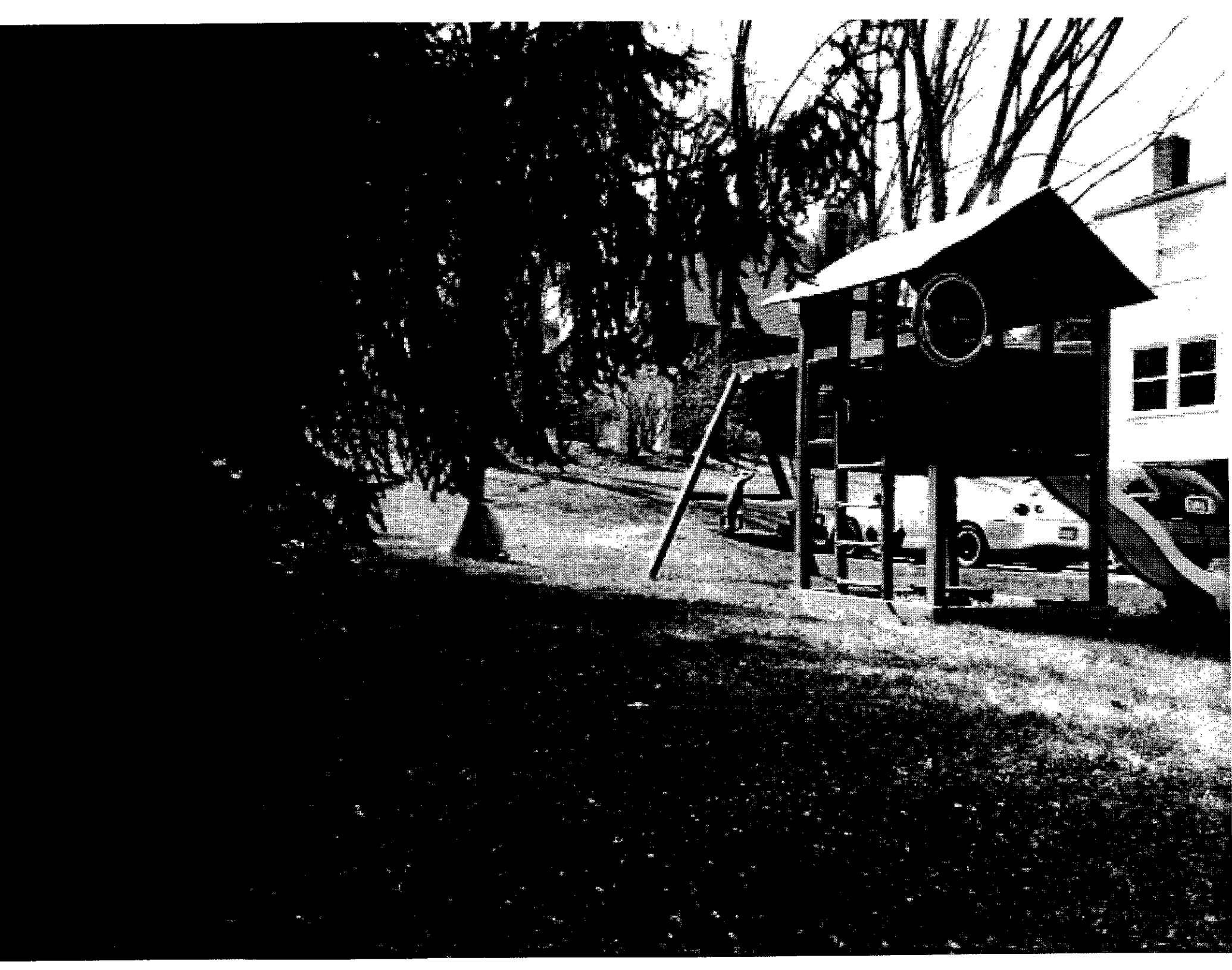

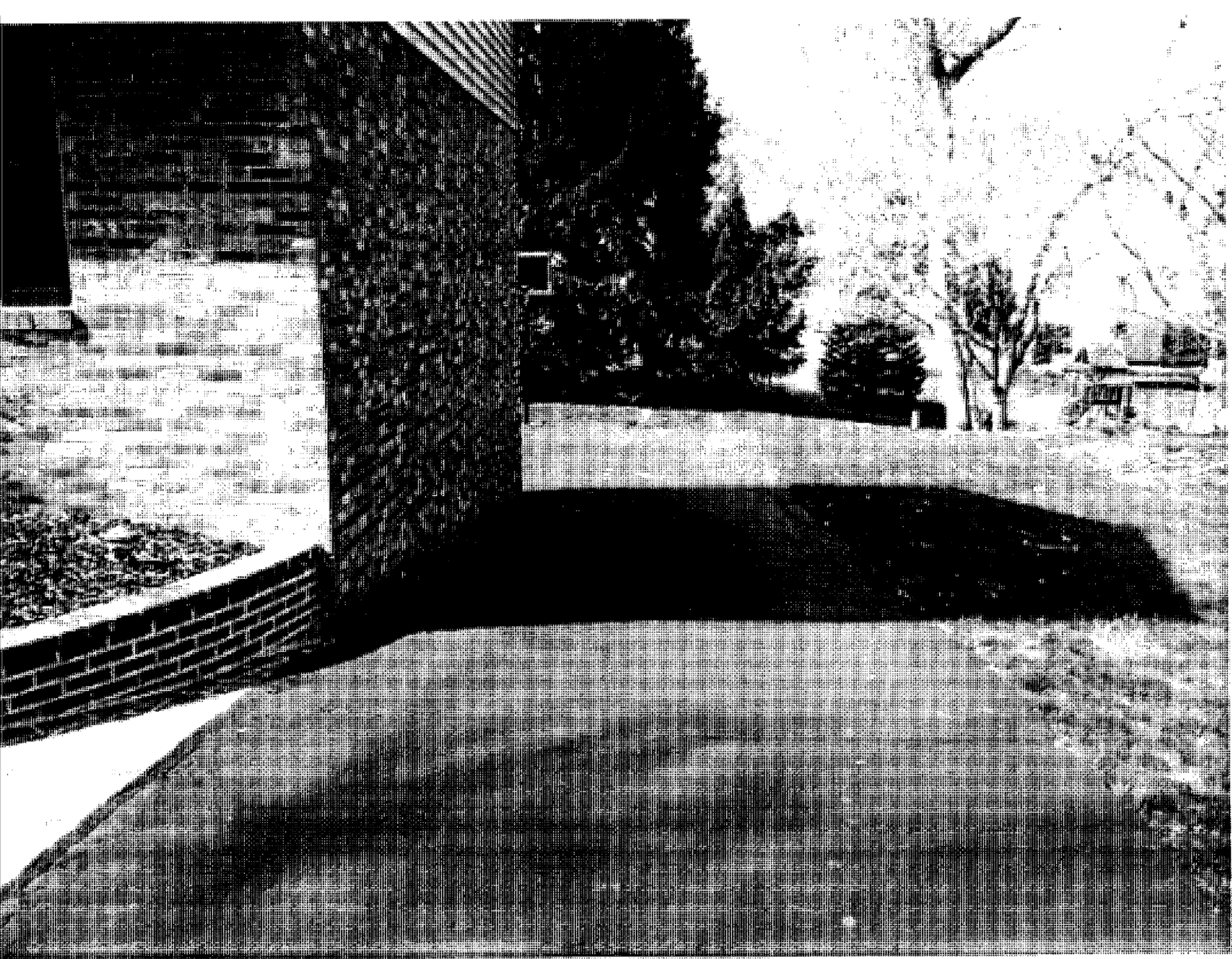



**Recall ID # 100823 - POWER TRAIN:AUTOMATIC  
TRANSMISSION**

 [Hide Details](#)

**Recall Date:**  
DEC 06, 2013

**Model Affected:**  
2013 Dodge Charger

**Summary:**

Chrysler Group LLC (Chrysler) is recalling certain model year 2013 Chrysler 300 AWD, Dodge Charger AWD, and Dodge Ram 1500 4x4 vehicles equipped with ZF all wheel drive ("AWD") 8HP45 transmissions. In the affected vehicles, the transmission output shaft may fracture.

**Consequences:**

The transmission output shaft fracture could result in a loss of power, increasing the risk of a crash. Additionally, if the parking brake is not applied *before exiting the vehicle*, the vehicle may roll away despite the transmission being placed in 'Park'.

**Remedy:**

Chrysler will notify owners, and dealers will inspect and replace the transmissions, as necessary, free of charge. The recall is to begin in January 2014. Customers may contact Chrysler at 1-800-853-1403. Chrysler's recall number is N65.

## Maggie Gentry

---

**From:** Mark Frawley  
**Sent:** Monday, April 21, 2014 9:54 AM  
**To:** Maggie Gentry  
**Cc:** Randall Dusek; Zulfiqar Zafar  
**Subject:** FW: Dodge Charger Safety Issue  
**Attachments:** photo 1.JPG; photo 2.JPG; photo 3.JPG; photo 4.JPG; photo 5.JPG; Charger Recall.JPG

Maggie,

This is a follow-up to my voice message... Please have someone contact the customer and handle on merits.

Please let me know if there is anything you need from me and if you could let both Randy and I know the corresponding Legal CAIR numbers just in case the customer calls and is looking for an update.

Thanks

Mark

---

**From:** [Michelle.Hire@us.vesuvius.com](mailto:Michelle.Hire@us.vesuvius.com) [<mailto:Michelle.Hire@us.vesuvius.com>]  
**Sent:** Monday, April 21, 2014 09:35 AM  
**To:** Randall Dusek  
**Subject:** Fw: Dodge Charger Safety Issue

Hi Randy,  
Please see the email below from one of my drivers. We have 7 employees currently driving 2013 Dodge Charger AWD. I have told the drivers to stop driving these Chargers immediately, until they can be repaired. I need to know why recall notices were not sent to these drivers. Also, I want to make sure that the drivers are given a loaner car to use until the repairs can be made.

Please call me as soon as possible to discuss.

Thanks,  
Michelle

**VESUVIUS**

**Michelle Hire**  
Financial Analyst

Vesuvius CP  
1404 Newton Drive  
Champaign, IL 61822  
Tel: 217-402-9824  
Fax: 217-351-5834  
[michelle.hire@us.vesuvius.com](mailto:michelle.hire@us.vesuvius.com)

---

[www.vesuvius.com](http://www.vesuvius.com)



----- Forwarded by Michelle Hire/CP/VESUVIUS on 04/21/2014 08:28 AM -----

**From:** Tom Roche/MOBILE/VESUVIUS  
**To:** Dan Flint/CP/VESUVIUS  
**Cc:** Michelle Hire/CP/VESUVIUS

Date: 04/17/2014 01:48 PM  
Subject: Dodge Charger Safety Issue

---

Dan,

I wanted to bring something to your attention regarding my company car, which is a 2013 Dodge Charger. Last night it jumped out of gear and rolled down our driveway into a pine tree that was approx 10-15 ft from a swing set that children were playing on. I emailed 3 of our other salesmen who have the same car and all 3 said they have experienced the same thing just not as serious as mine was. One of them said his car rolled into another car in a parking lot and would have rolled into a busy intersection had it not hit the other car..

I am going to attach some pictures from what happened to my car along with some info I found regarding a recall on 2013 Dodge Chargers. Right now 4 of us have experienced the same problem that when you think the car is in park it might drift on you or jump out of park. My car didn't drift when I got out to go back in the house and when I returned a minute later it was down in the pine tree.

-

Tom CONFIDENTIALITY NOTICE AND DISCLAIMER This message, including any attachments, contains confidential information which may also be privileged or otherwise protected by work product immunity or other legal rules. It is intended solely for the use of the individual or entity to whom they are addressed. If you have received this message in error, please notify the sender and remove it from your system. Any unauthorized review, disclosure, copying, distribution or use of this information is strictly prohibited. The Company accepts no liability for the content of this email or for the consequences of any actions taken on the basis of the information it contains.





















WARNING: CLEAN FILLER CAP BEFORE REMOVING. USE ONLY  
LIQUID FROM A SEALED CONTAINER.  
ATTENTION: NETTOYER LE BOUCHON DE REMPLISSAGE  
AVANT D'UTILISER LE LIQUIDE.  
NE PAS UTILISER UN LIQUIDE NON  
SCÉLÉ.



REMOVING - BEFORE REMOVING - AVANT DE L'ENLEVER - AVANT DE L'ENLEVER  
BEFORE REMOVING - AVANT DE L'ENLEVER - AVANT DE L'ENLEVER



















































































WARNING: CLEAN FILLER CAP BEFORE REMOVING. USE ONLY  
LIQUID FROM A SEALED CONTAINER.  
NETTOYER LE BOUCHON DE REMPLISSAGE  
UNIQUEMENT AVEC UN LIQUIDE  
D'UN CONTAINER SCELLE.  
NE PAS UTILISER D'AUTRE LIQUIDE.



REMOVING - MAINTENIR LE BOUCHON DE REMPLISSAGE AVANT DE L'ENLEVER - NE PAS UTILISER D'AUTRE LIQUIDE































































SE 45747mi 64°  
Press Brake  
and Push  
Button to  
Start

START STOP

P  
R  
N  
D  
L



BRAKE

48747mi 64°  
Start Engine  
to shift  
into gear

P  
R  
N  
D  
L





SE 48747mi 64°

Vehicle Speed

0 mph

change to km/h

LOW RPP

The central display shows vehicle information including SE, 48747mi, and 64°. The speed is 0 mph. A yellow car icon is visible below the speed. The text 'LOW RPP' is displayed vertically on the right side of the screen.





SE 48747mi 64°  
Vehicle Speed  
0 mph  
change to km/h  
L D N R P



**BRAKE**



SE 48747mi 64°  
Press Brake and  
Push Button to  
Shift into Gear

P  
R  
N  
D  
L

The central display shows a gear shift diagram with a yellow car icon and a highlighted 'P' gear. The text 'Press Brake and Push Button to Shift into Gear' is displayed above the diagram.



BRAKE





SE 48747mi 64°  
Press Brake and  
Push Button to  
Shift into Gear

P  
R  
N  
D

The image shows a central digital display with a red background. At the top, it displays 'SE 48747mi 64°'. Below that, it says 'Press Brake and Push Button to Shift into Gear'. In the center, there is a diagram of a gear shift lever with a red car icon below it. To the right of the diagram, the letters 'P R N D' are arranged vertically, with a white line indicating the current gear position is in 'P'.



**BRAKE**

order table elements.

Graph	Name	Value	Unit
<input type="checkbox"/>	Brake Pedal State	Pedal Pressed	
<input type="checkbox"/>	Brake Intervention by ESP Active	False	
<input type="checkbox"/>	Brake intervention by assistance system active	False	
<input type="checkbox"/>	Master cylinder pressure	822	psi
<input type="checkbox"/>	Wheel RPM Front Left	0.0	rpm
<input type="checkbox"/>	Wheel RPM Front Right	0.0	rpm
<input type="checkbox"/>	Wheel RPM Rear Left	0.0	rpm
<input type="checkbox"/>	Wheel RPM Rear Right	0.0	rpm
<input type="checkbox"/>	Transfer Case Status	Two Wheel Drive	
<input type="checkbox"/>	Oil Temperature	115	°F
<input type="checkbox"/>	Current Gear	Current Gear "P"	
<input type="checkbox"/>	Trans A/C Converter Clutch Slipping	False	
<input type="checkbox"/>	PRND Status	Lever in position "P"	
<input type="checkbox"/>	MIL on Request From the Transmission	False	
<input type="checkbox"/>	Engine Coolant Temperature	136	°F

odule

6.00

Online

wi



<input type="checkbox"/>	Brake Inhibition by ABS		
<input type="checkbox"/>	Master cylinder pressure	988	psi
<input type="checkbox"/>	Wheel RPM Front Left	0.0	rpm
<input type="checkbox"/>	Wheel RPM Front Right	0.0	rpm
<input type="checkbox"/>	Wheel RPM Rear Left	0.0	rpm
<input type="checkbox"/>	Wheel RPM Rear Right	0.0	rpm
<input type="checkbox"/>	Transfer Case Status	Two Wheel Drive	
<input type="checkbox"/>	Oil Temperature	115	°F
<input type="checkbox"/>	Current Gear	Current Gear "R"	
<input type="checkbox"/>	Trans A/C Converter Clutch Slipping	False	
<input type="checkbox"/>	PRND Status	Lever in Position "R"	
<input type="checkbox"/>	MIL on Request From the Transmission	False	
<input type="checkbox"/>	Engine Coolant Temperature	136	°F

A A

wi



Graph	Name	Value	Unit
<input type="checkbox"/>	Brake Pedal State	Pedal Pressed	
<input type="checkbox"/>	Brake Intervention by ESP Active	False	
<input type="checkbox"/>	Brake Intervention by assistance system active	False	
<input type="checkbox"/>	Master cylinder pressure	985	psi
<input type="checkbox"/>	Wheel RPM Front Left	0.0	rpm
<input type="checkbox"/>	Wheel RPM Front Right	0.0	rpm
<input type="checkbox"/>	Wheel RPM Rear Left	0.0	rpm
<input type="checkbox"/>	Wheel RPM Rear Right	0.0	rpm
<input type="checkbox"/>	Transfer Case Status	Two Wheel Drive	
<input type="checkbox"/>	Oil Temperature	115	°F
<input type="checkbox"/>	Current Gear	Current gear "N"	
<input type="checkbox"/>	Trans A/C Converter Clutch Slipping	False	
<input type="checkbox"/>	PRND Status	Lever in Position "N"	
<input type="checkbox"/>	MIL on Request From the Transmission	False	
<input type="checkbox"/>	Engine Coolant Temperature	136	°F

A A

wi



Brake Intervention by assistance system active	False
Master cylinder pressure	90
wheel RPM front Left	0.0
wheel RPM front Right	0.0
wheel RPM rear Left	0.0
wheel RPM rear Right	0.0
Transfer Case Status	Two wheel drive
Oil Temperature	110
Current Gear	Current gear 'D'
Trunk A/C Converter Output Warning	False
Wheel Status	Low in position 'D'
MS as Request from the Transmission	False
Engine Coolant Temperature	110

<input type="checkbox"/>	Brake Pedal State	Pedal Pressed
<input type="checkbox"/>	Brake Intervention by ESP Active	False
<input type="checkbox"/>	Brake intervention by assistance system active	False
<input type="checkbox"/>	Master cylinder pressure	995
<input type="checkbox"/>	Wheel RPM Front Left	0.0
<input type="checkbox"/>	Wheel RPM Front Right	0.0
<input type="checkbox"/>	Wheel RPM Rear Left	0.0
<input type="checkbox"/>	Wheel RPM Rear Right	0.0
<input type="checkbox"/>	Transfer Case Status	Two Wheel Drive
<input type="checkbox"/>	Oil Temperature	115
<input type="checkbox"/>	Current Gear	Current Gear "1"
<input type="checkbox"/>	Trans A/C Converter Clutch Slipping	False
<input type="checkbox"/>	PRND Status	Lever in position "D"
<input type="checkbox"/>	MIL on Request From the Transmission	False
<input type="checkbox"/>	Engine Coolant Temperature	136

A A

wi



Master Cylinder Pressure	0.0
Wheel RPM Front Left	0.0
Wheel RPM Front Right	0.0
Wheel RPM Rear Left	0.0
Wheel RPM Rear Right	0.0
Transfer Case Status	Two Wheel Drive
Oil Temperature	117
Current Gear	Current Gear 'P'
Trans & E Converter Check Warning	False
WMS Status	Lower In position 'P'
Oil as Request from the Transmission	False
Engine Coolant Temperature	118

<input type="checkbox"/>	Brake Intervention by ESP Active	False	
<input type="checkbox"/>	Brake Intervention by assistance system active	False	
<input type="checkbox"/>	Master cylinder pressure	985	psi
<input type="checkbox"/>	Wheel RPM Front Left	0.0	rpm
<input type="checkbox"/>	Wheel RPM Front Right	0.0	rpm
<input type="checkbox"/>	Wheel RPM Rear Left	0.0	rpm
<input type="checkbox"/>	Wheel RPM Rear Right	0.0	rpm
<input type="checkbox"/>	Transfer Case Status	Two Wheel Drive	
<input type="checkbox"/>	Oil Temperature	117	'F
<input type="checkbox"/>	Current Gear	Current Gear "P"	
<input type="checkbox"/>	Trans A/C Converter Clutch Slipping	False	
<input type="checkbox"/>	PRND Status	Lever in position "P"	
<input type="checkbox"/>	MIL on Request From the Transmission	False	
<input type="checkbox"/>	Engine Coolant Temperature	138	'F

A A

wi







<input type="checkbox"/>	Master cylinder pressure	1047
<input type="checkbox"/>	Wheel RPM Front Left	0.0
<input type="checkbox"/>	Wheel RPM Front Right	0.0
<input type="checkbox"/>	Wheel RPM Rear Left	0.0
<input type="checkbox"/>	Wheel RPM Rear Right	0.0
<input type="checkbox"/>	Transfer Case Status	Two Wheel Drive
<input type="checkbox"/>	Oil Temperature	124
<input type="checkbox"/>	Current Gear	Current Gear "1"
<input type="checkbox"/>	Trans A/C Converter Clutch Slipping	False
<input type="checkbox"/>	PRND Status	Lever in position "D"
<input type="checkbox"/>	MIL on Request From the Transmission	False
<input type="checkbox"/>	Engine Coolant Temperature	162

A A



Graph	Name	Value	Unit
<input type="checkbox"/>	Brake Pedal State	Pedal Pressed	Unit
<input type="checkbox"/>	Brake Intervention by ESP Active	False	
<input type="checkbox"/>	Brake Intervention by assistance system active	False	
<input type="checkbox"/>	Master cylinder pressure	1043	psi
<input type="checkbox"/>	Wheel RPM Front Left	0.0	rpm
<input type="checkbox"/>	Wheel RPM Front Right	0.0	rpm
<input type="checkbox"/>	Wheel RPM Rear Left	0.0	rpm
<input type="checkbox"/>	Wheel RPM Rear Right	0.0	rpm
<input type="checkbox"/>	Transfer Case Status	Two Wheel Drive	
<input type="checkbox"/>	Oil Temperature	126	°F
<input type="checkbox"/>	Current Gear	Current Gear "1"	
<input type="checkbox"/>	Trans A/C Converter Clutch Slipping	False	
<input type="checkbox"/>	PRND Status	Lever in position "D"	
<input type="checkbox"/>	MIL on Request From the Transmission	False	
<input type="checkbox"/>	Engine Coolant Temperature	165	°F

A A

wi



Click row selection to graph data element, or check multiple elements and press "New Graph" to add to data element table elements.

ch	Name	Units	Min	Max	Graph	Table
<input type="checkbox"/>	Brake Pedal State	0/1				
<input type="checkbox"/>	Brake Intervention by ESP Active	0/1				
<input type="checkbox"/>	Brake Intervention by assistance system active	0/1				
<input type="checkbox"/>	Master cylinder pressure	bar				
<input type="checkbox"/>	Wheel RPM Front Left	rpm				
<input type="checkbox"/>	Wheel RPM Front Right	rpm				
<input type="checkbox"/>	Wheel RPM Rear Left	rpm				
<input type="checkbox"/>	Wheel RPM Rear Right	rpm				
<input type="checkbox"/>	Transfer Case Status	Transfer Case				
<input type="checkbox"/>	Oil Temperature	°C				
<input type="checkbox"/>	Current Gear	Current Gear				
<input type="checkbox"/>	Trans A/C Converter Clutch Slipping	False				
<input type="checkbox"/>	PRND Status	PRND				
<input type="checkbox"/>	MIL on Request From the Transmission	0/1				
<input type="checkbox"/>	Engine Coolant Temperature	°C				

A



SE 48747mi 64°  
Press Brake and  
Push Button to  
Shift into Gear



P  
R  
N  
D  
L



**BRAKE**



order table elements

Graph	Name	Value	Unit
<input type="checkbox"/>	Brake Pedal State	Pedal Up/Stopped	
<input type="checkbox"/>	Brake Intervention by ESP Active	False	
<input type="checkbox"/>	Brake Intervention by assistance system active	False	
<input type="checkbox"/>	Master cylinder pressure	0	psi
<input type="checkbox"/>	Wheel RPM Front Left	0.0	rpm
<input type="checkbox"/>	Wheel RPM Front Right	0.0	rpm
<input type="checkbox"/>	Wheel RPM Rear Left	0.0	rpm
<input type="checkbox"/>	Wheel RPM Rear Right	0.0	rpm
<input type="checkbox"/>	Transfer Case Status	Two Wheel Drive	
<input type="checkbox"/>	Oil Temperature	115	°F
<input type="checkbox"/>	Current Gear	Current Gear "P"	
<input type="checkbox"/>	Trans A/C Converter Clutch Slipping	False	
<input type="checkbox"/>	PRND Status	Lever in position "P"	
<input type="checkbox"/>	MIL on Request From the Transmission	False	
<input type="checkbox"/>	Engine Coolant Temperature	136	°F

A A



	Value	
Pedal Pressed	False	
False	False	
Drive intervention by ESP Active	False	
Drive intervention by assistance system active	False	
Water cylinder pressure	1043	psi
Wheel RPM Front Left	0.0	rpm
Wheel RPM Front Right	0.0	rpm
Wheel RPM Rear Left	0.0	rpm
Wheel RPM Rear Right	0.0	rpm
Transfer Case Status	Two Wheel Drive	
Oil Temperature	127	°F
Current Gear	Current Gear "1"	
Trans A/C Converter Clutch Slipping	False	
PRND Status	Lever in position "D"	
MIL on Request From the Transmission	False	
Engine Coolant Temperature	165	°F



SE 48750mi 49°  
Press Brake and  
Push Button to  
Shift into Gear



P  
R  
N  
D  
L



SE 48750mi 49°  
Press Brake and  
Push Button to  
Shift into Gear



P  
R  
N  
D  
L

































DODGE













































WARNING: CLEAN FILLER CAP BEFORE REMOVING. USE ONLY  
LIQUID FROM A SEALED CONTAINER.  
NETTOYER LE BOUCHON DE REMPLISSAGE  
UNIQUEMENT AVEC UN LIQUIDE  
D'UN CONTAINER SCHEMATEMENT  
SCHEMATEMENT





















04627731AB-A











# Vehicle View

Roll over an ECU to see full name. Click on an ECU for complete details.

2013 LD 3.6L

VIN: 2C3CDXJG9DH

Battery: 11.92 volts

### Legend

- Active ECU
- Non-responsive ECU
- DTCs Present
- ECU Not built
- ↻ Scanning ECU
- + New Flash Available
- CAN-C
- CAN-HS

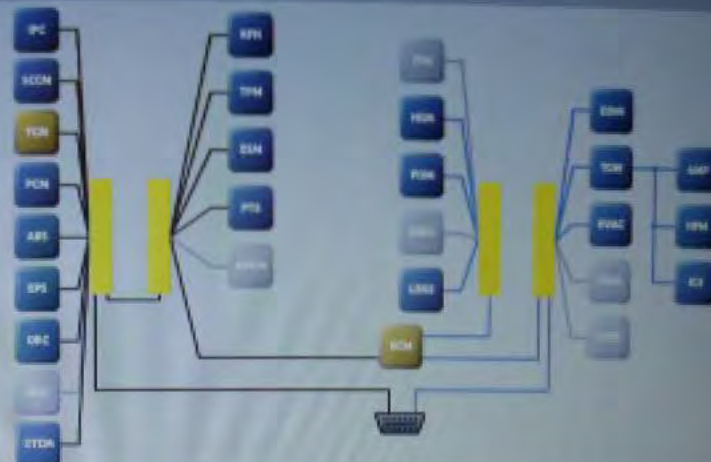

All DTCs Diagnostic Procedures Customer Preferences Vehicle Preparations

Double-click row selection to view environmental data. Click on column heading to sort table.

All Active Stored Pending

View Event Data

ECU	Code	Status	Description
TCM	P10C7-00	Stored	Clutch Temp Threshold Achieved - Shift Time Reduction
TCM	P1915-00	Stored	Transmission Inhibited Remote Start
BCM	R1673-15	Active	Driver Shift Solenoid/Kick Lamps Control Circuit Short to Battery/Chassis

Knowledge Base Articles

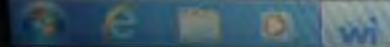

Double-click row selection to view environmental data. Click on column heading to sort table.

All | Active | Stored | Pending

ECU	Code	Status	Description
There are no DTCs present			

View Error Codes View Error Codes



Double-click row selection to view environmental data. Click on column heading to sort table.

 View Freeze Frame

 View Event

All | Active | Stored | Pending

	ECU	Code	Status	Description
There are no DTCs present				

1 A





# Vehicle View

Click on an ECU to see full name. Click on an ECU for complete details.

Search Service Information

2013 LD 3.6L  
 VIN: 2C3CDXJG9DH511999  
 Battery: 13.08 volts

**Legend**

- Active ECU
- Non-responsive ECU
- DTCs Present
- ECU Not Built
- Scanning ECU
- New Flash Available
- CAN-C
- CAN-HS

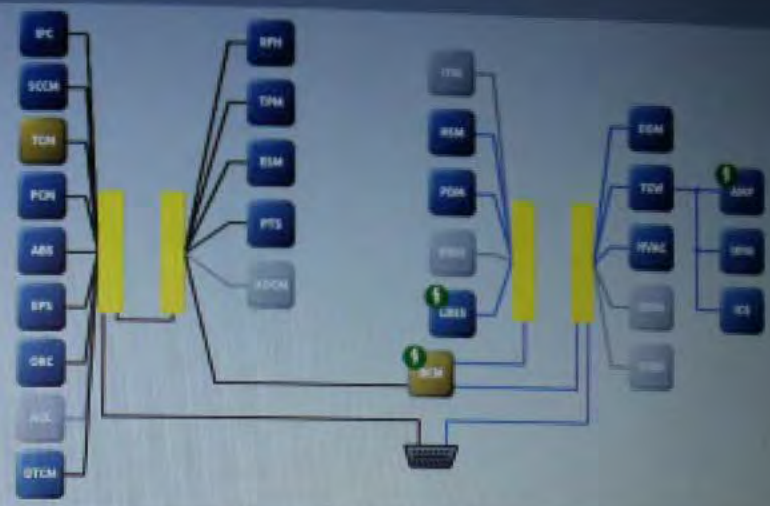

All DTCs Diagnostic Procedures Customer Preferences Vehicle Preparations

Double-click row selection to view environmental data. Click on column heading to sort table.

All Active Stored Pending

ECU View Freeze Frame View Events

ECU	Code	Status	Description
TCM	P1DC7-00	Stored	Clutch Temp Threshold Achieved - Shift Time Reduction
TCM	P1915-00	Stored	Transmission Inhibited Remote Start
PCM	B16C3-15	Active	Front Right Side-ackler Lamp Control Circuit Short to Battery or Gnd

Knowledge Base Articles

Online

Windows taskbar with icons for Internet Explorer, File Explorer, and Wi-Fi.







Component

Name

Transmission Control Module

Part Part Number

XXXXXXXXXX

Part Type

ECU

Hardware Version

10.20.07

Software Version

40 10.20.00, 40 10.20.00

Spec Part Number

Not Available

Alt Code

Software Number

Not Available

Hardware Number

Not Available

Original P/N

10.20.00.0000

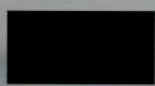

Three Rivers

Jeep



[Redacted information]

(W-89-A)

ESTIMATE BY LAW YOU RECEIVE FIRST TO AN ESTIMATE OF THE EXPECTED COST OF REPAIRS OR SERVICES

INITIAL YOUR CHOICE

- \_\_\_\_\_ WRITTEN ESTIMATE
- \_\_\_\_\_ ORAL ESTIMATE
- \_\_\_\_\_ NO ESTIMATE

DAN

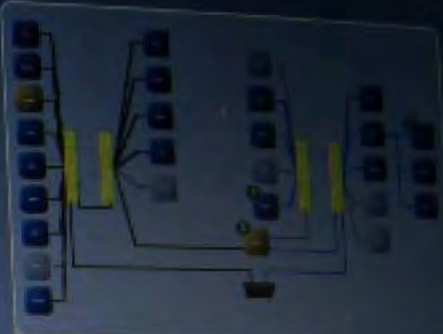

Overview

**Name:** Transmission Control Module  
**Flash Part Number:** 68046525AL  
**Bus Type:** CAN C  
**Hardware Version:** 0A.03.1F  
**Software Version:** #0: 12.26.00, #1: 12.26.00  
**Spare Part Number:** Not Available  
**ISO Code:**  
**Software Number:** Not Available  
**Hardware Number:** Not Available  
**Original VIN:** 2C3CDXJG9DHS [Redacted]

Knowledge Base Articles

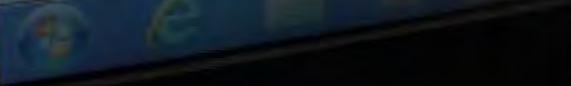





SE 48750mi 49°  
Press Brake and  
Push Button to  
Shift into Gear



P  
R  
N  
D  
L





SE 48750mi 49°  
Press Brake and  
Push Button to  
Shift into Gear



P  
R  
N  
D  
L









MFD BY CHRYSLER GROUP LLC

DATE OF MFR/BUILT: OCT 12

GWR: 02495 KG

GAWR: 01275 KG

GAWR: 01275 KG

05500 LB

FRONT: 02010 LB

REAR: 02010 LB



THIS VEHICLE CONFORMS TO ALL APPLICABLE U.S.A. FEDERAL MOTOR VEHICLE SAFETY,  
BUMPER AND THEFT PREVENTION STANDARDS IN EFFECT ON  
THE DATE OF MANUFACTURE SHOWN ABOVE.

VIN: 2C3CDKJG90

NM: 002917 033AA

VEHICLE MADE IN CANADA

PAINT: PA0

TWO-PASSENGER CAR

1000: BT0F

443300473

10  
A

10  
A

ZC3CDXJG9D [REDACTED]

MFD BY CHRYSLER GROUP LLC

DATE OF MFR (BUILT): 5-13

GWR: 01944 KG

GWR: 01076 KG

GWR: 00901 KG

04285 LB

FRONT: 02370 LB

REAR: 01985 LB

THIS VEHICLE CONFORMS TO ALL APPLICABLE U.S.A. FEDERAL MOTOR VEHICLE SAFETY,  
BUMPER AND THEFT PREVENTION STANDARDS IN EFFECT ON  
THE DATE OF MANUFACTURE SHOWN ABOVE.



VIN: 1C3CDFCH

TYPE: PASSENGER CAR

KM: 052187 02640

PLANT: AIG

DRIVE: 2WD

VEHICLE MADE IN U.S.A.

40088413



Key In  
Ignition

0220



16441 ml















DODGE

CHARGER  
RWD

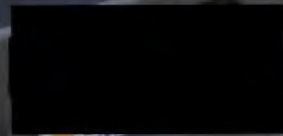



DODGE

CHARGER  
SUV





















MFD BY CHRYSLER GROUP LLC

DATE OF MFR (BUILT): 5-13

GWR: 01944 KG

GWR: 01076 KG

GWR: 00901 KG

04285 LB

FRONT: 02370 LB

REAR: 01985 LB

THIS VEHICLE CONFORMS TO ALL APPLICABLE U.S.A. FEDERAL MOTOR VEHICLE SAFETY,  
BUMPER AND THEFT PREVENTION STANDARDS IN EFFECT ON  
THE DATE OF MANUFACTURE SHOWN ABOVE.



VIN: 1C3CDFCH

TRUCK PASSENGER CAR

KM: 052187 02648

PLANT: AIG

0800 0707

VEHICLE MADE IN U.S.A.

40208413



Key In  
Ignition

0220



16441 ml















DODGE

CHARGER  
S&P

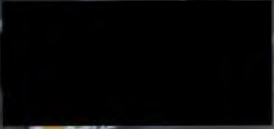



DODGE

CHARGER  
S&W





















**⚠ WARNING**

**EVEN WITH ADVANCED AIRBAGS**

- CHILDREN CAN BE KILLED OR SERIOUSLY INJURED BY THE AIRBAG.
- THE BACK SEAT IS THE SAFEST PLACE FOR CHILDREN.
- NEVER PUT A REAR-FACING CHILD SEAT IN THE FRONT.
- ALWAYS USE SEATBELTS AND CHILD RESTRAINTS.
- SEE OWNER'S MANUAL FOR MORE INFORMATION ABOUT AIRBAGS.



05108 114AA

**⚠ MISE EN GARDE**

**MÊME AVEC DES SACS GONFLABLES PERFECTION**

- LES ENFANTS PEUVENT ÊTRE TUÉS OU GRAVEMENT BLESSÉS PAR UN SAC GONFLABLE.
- LA BANQUETTE ARRIÈRE EST LA PLACE LA PLUS SÛRE POUR LES ENFANTS.
- NE JAMAIS PLACER UN SIÈGE POUR ENFANT ORIENTÉ VERS L'ARRIÈRE À L'AVANT DU VÉHICULE.
- ÉVITONS D'UTILISER LES CRÉATIONS DE SÉCURITÉ ET LES SYSTÈMES DE RETENUE POUR ENFANT.
- CONSULTEZ LE GUIDE DE L'ACTUOBSCALISTE POUR OBTENIR PLUS DE RENSEIGNEMENTS SUR LES SACS GONFLABLES.

## **⚠ WARNING**

### **EVEN WITH ADVANCED AIRBAGS**

- CHILDREN CAN BE KILLED OR SERIOUSLY INJURED BY THE AIRBAG.
- THE BACK SEAT IS THE SAFEST PLACE FOR CHILDREN.
- NEVER PUT A REAR-FACING CHILD SEAT IN THE FRONT.
- ALWAYS USE SEATBELTS AND CHILD RESTRAINTS.
- SEE OWNER'S MANUAL FOR MORE INFORMATION ABOUT AIRBAGS.



05108 114AA

## **⚠ MISE EN GARDE**

### **MÊME AVEC DES SACS GONFLABLES PERFECTIENNÉS**

- LES ENFANTS PEUVENT ÊTRE TUÉS OU GRAVEMENT BLESSÉS PAR UN SAC GONFLABLE.
- LA BANQUETTE ARRIÈRE EST LA PLACE LA PLUS SÛRE POUR LES ENFANTS.
- NE JAMAIS PLACER UN SIÈGE POUR ENFANT ORIENTÉ VERS L'ARRIÈRE À L'AVANT DU VÉHICULE.
- NE JAMAIS UTILISER LES CONTENES DE SÉCURITÉ ET LES SIÈGES DE BÉBÉ POUR ENFANT.
- CONSULTER LE MANUEL DE L'AUTOMOBILE POUR OBTENIR PLUS DE RENSEIGNEMENTS SUR LES SACS GONFLABLES.



## ▲ WARNING

### EVEN WITH ADVANCED AIRBAGS

- CHILDREN CAN BE KILLED OR SERIOUSLY INJURED BY THE AIRBAG.
- THE REAR SEAT IS THE SAFEST PLACE FOR CHILDREN.
- NEVER PUT A REAR-FACING CHILD SEAT IN THE FRONT.
- ALWAYS USE SEATBELTS AND CHILD RESTRAINTS.
- SEE OWNER'S MANUAL FOR MORE INFORMATION ABOUT AIRBAGS.



05108114AA

## ▲ MISE EN GARDE

### MÊME AVEC DES SACS GONFLABLES PERFECTIONNÉS

- LES ENFANTS PEUVENT ÊTRE TUÉS OU GRAVEMENT BLESSÉS PAR UN SAC GONFLABLE.
- LA BANQUETTE ARRIÈRE EST LA PLACE LA PLUS SÛRE POUR LES ENFANTS.
- NE JAMAIS PLACER UN SIÈGE POUR ENFANT ORIENTÉ VERS L'ARRIÈRE À L'AVANT DU VÉHICULE.
- TOUJOURS UTILISER LES CEINTURES DE SÛRETÉ ET LES SYSTÈMES DE RETENUE POUR ENFANT.
- CONSULTER LE GUIDE DE L'AUTOMOBILISTE POUR OBTENIR PLUS DE RENSEIGNEMENTS SUR LES SACS GONFLABLES.

© 2005 GM Corp. All rights reserved. Airbag use is restricted. See Owner's Manual for details. Airbag use is restricted. See Owner's Manual for details. Airbag use is restricted. See Owner's Manual for details. Airbag use is restricted. See Owner's Manual for details.





05 40000 04  
Transmission  
0  
000000  
P



ABS



**BRAKE**



**BRAKE**







SE 48747mi 64°  
Vehicle  
Not in  
Park

DRIVEN



**BRAKE**





AIRBAG















AIR BAG



**HILNOS**

118 Avenue Kasselberg  
Boulevard Humber 811

**ESTABLISHED**

RETAILER

















































EA16-002

FLAT CHRYSLER

5-12-2016

ENCLOSURE 04

CAIR Backup



**CHRYSLER**

---

June 6, 2014

[REDACTED]  
Berwyn, PA [REDACTED]

CAIR: [REDACTED]

Dear Mr. [REDACTED]

I have had the opportunity to review the inspection report generated by our engineering firm and must advise you that we have been unable to determine a problem with your 2013 Dodge Charger.

The transmission, linkage, parking pawl, and all related systems were checked very carefully. Also, a test drive, as well as a physical and electronic inspection of the unit indicates that the transmission is operating properly.

As stated in your owner's manual, Chrysler Group LLC recommends that the gear selector be placed in park with an automatic transmission and first gear with a manual transmission, the parking brake fully set, the ignition turned off, and the keys removed whenever the vehicle is left unattended. Therefore, we must respectfully decline participation with any costs associated with this incident.

We also suggest you refer to your owner's manual regarding the eight speed transmission and proper shifting procedure.

Thank you for giving us the opportunity to inspect, review and advise you in this matter.

Sincerely,

M. Gentry  
Special Investigations  
586-274-8160

MG/ss

Phone 800.992.1997

Chrysler Group LLC | CIMS 484-04-04 | P.O. Box 21-8004 | Auburn Hills, MI USA | 48321



YOUR SURPRISE COST

SALES & SERVICE



AIR  
FORCE  
AIR TITLES

Insurance & Plans



**YOUR  
SOURCE  
FOR TIRES**



PUSH  
ON/OFF







CHARGER





















YOUR













E 48970mi 57°

Press Brake and  
Push Button to  
Shift into Gear



P  
R  
N  
D  
L



P  
R  
N  
D/L

W

48971mi

57°

Park  
Assist



Ready



P  
R  
N  
D  
L

MPH  
km/h



A close-up photograph of a black, leather-like gear shifter knob. The knob is mounted on a silver-colored metal base. On the top surface of the knob, there is a silver-colored oval plate with a gear pattern. The letters 'P', 'R', 'N', and 'D/L' are printed vertically in white on this plate. To the right of the knob, a portion of a silver-colored metal handbrake is visible. The background is a dark, textured surface, likely the car's interior floor or console.

P  
R  
N  
D/L



Overview

Name:

Transmission Control Module

Flash Part Number:

68046525AL

Bus Type:

CAN C

Hardware Version:

0A.03.1F

Software Version:

#0: 12.26.00, #1: 12.26.00

Spare Part Number:

Not Available

ISO Code:

Software Number:

Not Available

Hardware Number:

Not Available

Original VIN

2C3CDXJG5DH [REDACTED]

Current VIN

2C3CDXJG5DH [REDACTED]

Variant & Year

68 - 08

Country Code

USA

DTC Count

0

ECU

Group

Overview

**Name:**

Electronic Shifter

**Flash Part Number:**

68140727AD

**Bus Type:**

CAN C

**Hardware Version:**

08.17.00

**Software Version:**

#0: 11.47.00, #1: 11.47.00

**Spare Part Number:**

Not Available

**ISO Code:**

**Software Number:**

Not Available

**Hardware Number:**

Not Available

**Original VIN**

Invalid

**Current VIN**

Invalid

**Variant & Version:**

42-01

**Country Code:**

N/A

**DTC Count:**

0

ECU

ECU

Overview

Name:  
Powertrain Control Module  
Flash Part Number:  
68171336AC  
Bus Type:  
CAN C  
Hardware Version:  
12.47  
Software Version:  
11.02.00  
Spare Part Number:  
not available  
ISO Code:  
  
Software Number:  
not available  
Hardware Number:  
not available  
Original VIN  
1C3CDXJG5DH [REDACTED]  
Current VIN  
1C3CDXJG5DH [REDACTED]  
Variant & Version  
23 - A6  
Country Code  
USA  
BTC Count:  
0















0.0



F58046525AL

0.1X





0



X1.2



Heavy Duty



X1.2

0.0

056297684



17783

OF NFR(BUILT): OCT 12

GAAR: 01275 KG

REAR: 02810 LB

ALL MOTOR VEHICLE SAFETY,  
EFFECT ON



VIN: 2C3CDKJG5 [REDACTED]

TYPE: PASSENGER CAR

MDH: 101510 033AA

PAINT: PK3

TRIM: 07X3

VEHICLE MADE IN CANADA

4000040

MFD BY CHRYSLER GROUP LLC DATE OF MFG/BUILD: OCT 12

GAW: 02495 KG  
05500 LB

GAW: 01275 KG  
FRONT: 02810 LB

GAW: 01275 KG  
REAR: 02810 LB



THIS VEHICLE CONFORMS TO ALL APPLICABLE U.S.A. FEDERAL MOTOR VEHICLE SAFETY,  
BUMPER AND THEFT PREVENTION STANDARDS IN EFFECT ON  
THE DATE OF MANUFACTURE SHOWN ABOVE.

VIN: 2C3CDKJ...  
YOM: 101510 02399  
VEHICLE NO. IN CHINA

















W 48971mi 57°

Press Brake and  
Push Button to  
Shift into Gear



P  
R  
N  
D  
L

MPH  
km/h



W 48971 mi 57°

Vehicle Speed

0 mph

change to km/h



P  
R  
N  
D  
L





P  
R  
N  
D/L

W 42971 mi 57°

Vehicle Speed

0 mph

change to km/h



P  
R  
N  
L  
D



P  
R  
N  
D/L

SE 48976mi 59°

Press Brake and  
Push Button to  
Shift into Gear



P  
R  
N





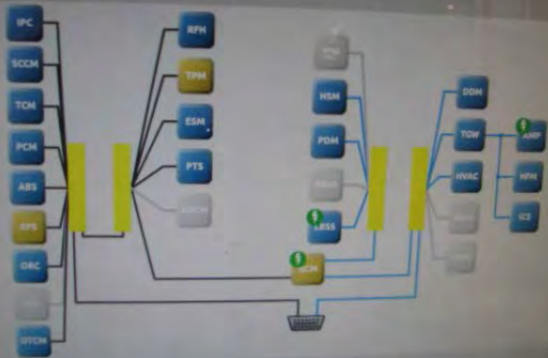

- Non-responsive ECU
- DTCs Present
- ECU Not Built
- Scanning ECU

All DTCs Diagnostic Procedures Customer Preferences Vehicle Preparations

Double-click row selection to view environmental data. Click on column heading to sort table.

All Active Stored Pending

Clear Stored DTCs

ECU	Code	Status	Description
BCM	U0232-00	Stored	Lost Communication with Blind Spot Detection Module
EPS	00415-00	Stored	Implausible Data Received from ABS
TPM	C1501-06	Stored	Tire Pressure Sensor 1-Component Internal Failure