

EA16-002

FLAT CHRYSLER

5-12-2016

ENCLOSURE 04

CAIR Backup

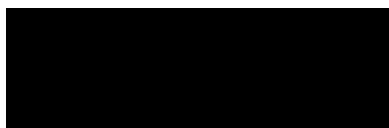



August 6, 2013

[REDACTED]  
Waldorf, MD [REDACTED]

RE: Our File: [REDACTED]  
VIN: 2C3CDXHG2CH [REDACTED]

Dear Ms. [REDACTED]

This is in regard to the inspection that was performed on your 2012 Dodge Charger.

Naturally, we were sorry to learn of this incident, especially in view of the inconvenience involved. We appreciate the opportunity to look into this matter.

As stated in your owner's manual, Chrysler Group LLC recommends that the gear selector be placed in park, the parking brake set, the ignition turned off, and the keys removed whenever the driver exits the vehicle. This provides for two methods of securing the vehicle against unintended movement, and is consistent with the laws of most States. It is our understanding that all of these conditions were not met during this occurrence. We encourage you to follow these steps at all times.

The transmission, linkage, parking brake, and all other related systems on your vehicle were checked very carefully. The inspection revealed that when all of the above steps were followed, the vehicle would not move by itself. In view of this, we must respectfully decline participation with any costs associated with this incident.

Based on this information, we can only suggest that you refer this matter to your insurance carrier. Should they feel a manufacturing responsibility exists, they have full subrogation rights under the terms of your policy.

Thank you for allowing us the opportunity in reviewing this matter with you.

Sincerely,

J. S. Susalla  
Special Investigations  
(586) 274-8171



CHRYSLER GROUP LLC  
JS SUSALLA  
PO BOX 218004  
AUBURN HILLS MI, 48321-8004

Date Printed: 9/24/2013 12:28:47 PM

subject: Your File Number: [REDACTED] Case Docketed; Your Insured: CHRYSLER GROUP LLC; AF Case Number: [REDACTED]

This is your notice that arbitration has been filed.

**Case Information:**

AF Case Number: [REDACTED]

Related AF Case Number

Your File Number: [REDACTED]

Your Insured: CHRYSLER GROUP LLC

Injured Party:

Your Representative: JS SUSALLA

Date of Loss: 7/27/2013

Loss State: ME

**Schedule Information:**

Materials Due Date: 10/25/2013

Ready To Hear Date: 11/11/2013

**Please note that all responses, amendments, and evidence must be received by 10/25/2013.**

Please visit [www.arbfile.org](http://www.arbfile.org) or email us at [status@arbfile.org](mailto:status@arbfile.org) with specific inquiries.

Sincerely,  
Arbitration Forums, Inc.  
Industry Created. Membership Driven.

AF has revised Rules 2-9 and 2-10, based on member feedback, to eliminate unwarranted delays in resolving claims. These revisions became effective June 15, 2013, and apply to all legacy cases (pending cases previously filed) and new filings. For more information and to review the rules, visit the AF Web site.

This message and any attachments are to be considered confidential and legally privileged. If you are not the intended recipient, or if this message has been addressed to you in error, kindly advise us by emailing [status@arbfile.org](mailto:status@arbfile.org) or calling 1-866-977-3434. Thank you for your assistance.

9-25  
**RECEIVED**  
OCT 01  
**SPECIAL INVESTIGATIONS**



**ARBITRATION FORUMS, INC.**

*Industry created. Membership driven.*

Member Service Department  
3350 Buschwood Park Drive, Suite 295  
Tampa, FL 33618

POSTNET  
018-13503473  
0933634  
**\$00.38<sup>4</sup>**  
09 25 2013  
FIRST-CLASS MAIL

# ARBITRATION APPLICATION

115 HM1B436 48321

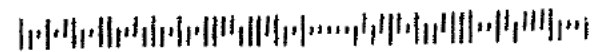

**CONFIDENTIAL - Prior Approval Required Before Duplicating**  
**Preliminary Vehicle Investigation Report(PVIR)**

CAIR# [REDACTED]

YEAR	BRAND	VEHICLE IDENTIFICATION NUMBER	MO/DY-HR	ODOMETER	IN-SERVICE
2012	DODGE CHARGER RALLYE RWD FOUR DOOR SEDAN	2C3CDXHG2CH154371	10-24 08	3847	12/15/2012
NAME OF OWNER		ADDRESS/LOCATION	CITY	STATE	COUNTRY
[REDACTED]		[REDACTED]	WALDORF	MD	USA
ZIP	COLOR	MODEL	HOME PHONE	BUSINESS PHONE	
[REDACTED]	Bright Silver Metallic Clear Coat	LDD	[REDACTED]		
SELLING DEALER NAME		BUSINESS CENTER	DLR. CODE	CITY	STATE
WALDORF DODGE		35	44519	WALDORF	MD
INSPECTOR - NAME FIRST, LAST, MIDDLE		INSPECTOR'S COMPANY		INSPECTOR'S PHONE NO.	
David Goldiner		EAA		215-275-8755	
DAMAGE ESTIMATE			REPAIR ESTIMATE		
<input checked="" type="radio"/> MINOR <input type="radio"/> MODERATE <input type="radio"/> TOTAL LOSS			\$ 1500.00		

**INTERVIEW**

INTERVIEW WITH:                       DRIVER    OWNER    OTHER    DRIVER/OWNER

NAME: LAST, FIRST, MIDDLE              Reynolds Kathryn

INTERVIEW DATE:              DATE OF INCIDENT:              TIME OF INCIDENT              INSPECTION DATE:  
**07/30/2013**                      **07/24/2013**                      **11:45**  AM    PM                      **07/31/2013**

1. DRIVER'S DESCRIPTION OF EVENT:              **Vehicle will roll forward when the gear shifter is in park position. The vehicle rolled in park twice once at home impacting the garage and another time at the Target parking lot. Both times the vehicle gear shifter was in the park position when the vehicle rolled. The parking brake was not applied. The customer is requesting Chrysler to be responsible for repairs repair the vehicle as necessary. No personal injuries, minor front bumper damage, airbags did not deploy, and seat belt(s) pretensioners did not activate.**

Insurance Company Name:  
 Personal Injury:                      Were there Personal Injuries?                      If Yes, complete section "B"  
 Yes    No  
 Any Indicator/Warning Lights on Prior?                      If Yes, What light:  
 Yes    No

**IMPORTANT: SHOW THIS REPORT TO NO ONE & ONLY STATE FACTS (DRAW NO CONCLUSIONS)**

Help Key

**PART A- GENERAL**

<p><b>REQUIRED PHOTOGRAPHS:</b>  <input checked="" type="checkbox"/> ALL FOUR SIDE VIEWS  <b>IF CRASH DAMAGED:</b>                  PERSPECTIVE FROM EVERY CORNER OF VEHICLE DOWN BOTH ORIGINAL LATERAL SIGHT LINES(8 TOTAL)                  - ANY RECENT VEHICLE SERVICE</p>	<p><b>INFORMATION:</b>  <input checked="" type="checkbox"/> POLICE/AGENCY REPORT #: <b>N/A</b>  <input checked="" type="checkbox"/> ALL REPORTS/PHOTOS BY OTHERS                  - ADDRESS OF INSPECTION                  Address <b>2450 Crain Highway</b>  <b>1</b>                  Address</p>	<p>- EVIDENCE OF TAMPERING OR PRIOR DISASSEMBLY   <input type="radio"/> YES   <input checked="" type="radio"/> NO                  - IF YES, DESCRIBE AND PHOTOGRAPH</p>
--	---	--

YES  NO  
 UNKNOWN  
IF YES, ENCLOSE COPIES OF  
REPAIR ORDERS

2  
City **Waldorf**  
State **MD**  
Zip **20601**  
Phone **301-843-2400**

---

**PART B - EXTERIOR/INTERIOR VEHICLE DAMAGE**

---

**REQUIRED PHOTOGRAPHS:** Exterior damage to from bumper cover from the impact. No other damage to the vehicle. No injuries to driver or occupants.

- WINDSHIELD
- ALL AREAS OF DAMAGE  
MARKINGS ON INTERIOR  
AND EXTERIOR
- CLOSE UPS OF STAINS,  
SKIN, HAIR, CLOTH
- EXTERIOR AND INTERIOR  
DAMAGE INCLUDING  
UNDERCARRIAGE

**INFORMATION:**

- DESCRIBE ANY INJURIES TO  
DRIVER AND/OR OTHER  
OCCUPANTS
  - SEE SEAT BELT/SEATS  
SECTION IF APPLICABLE
- 

Next

**PART C - AIRBAG(S)**

**REQUIRED PHOTOGRAPHS**

- STEERING WHEEL
- AIRBAG(S)
- KNEE BLOCKERS
- ALL POSSIBLE LOCATIONS OF CONTACT

**AECM INFORMATION**

- SOFTWARE VERSION:

**0B.0B.00**

- SERIAL NUMBER :

**T52md229101431**

- PART NUMBER :

**56054077A1**

- DOES AIRBAG WARNING LIGHT CYCLE ON?

YES  NO  N/A

- ARE WARNING LABELS PRESENT (PHOTO)

YES  NO  N/A

- RECORD LABEL PART NUMBER

**05108-114AA**

**COMPLETE PART D**

- PHOTOGRAPH REQUIRED FOR DRB SCREENS & RECORD FAULTS  
 - WERE THERE DRB READINGS TAKEN?

YES  NO IF NO, EXPLAIN

<b>- RECORD ACTIVE DTC'S EXACTLY AS APPEAR :</b>	<b>MIN</b>	<b>COUNT</b>
none		
<b>- RECORD STORED DTC'S (MINUTES/COUNTS) :</b>	<b>MIN</b>	<b>COUNT</b>
none		

- WAS AIRBAG DEPLOYED?

DRIVER  YES  NO

IF NO, EXPLAIN **UNKNOWN**

PASSENGER  YES  NO

IF NO, EXPLAIN **UNKNOWN**

SIDE AIRBAG  YES  NO  N/A

IF NO, EXPLAIN **UNKNOWN**

- WHICH SIDE DEPLOYED?

LEFT  RIGHT  N/A  BOTH

- TYPE OF SIDE AIRBAG

SEAT  CURTAIN  N/A

- TYPE OF STEERING WHEEL

TILT  STANDARD

- ANY DAMAGE TO STEERING WHEEL

YES  NO

IF YES, EXPLAIN

**DO NOT ERASE DRB READINGS**

IS VEHICLE EQUIPPED WITH PASSENGER AIRBAG DEFAULT SWITCH?

YES  NO

IF YES,

NOTE POSITION OF PASSENGER A/B SWITCH

ON  OFF  N/A

- EVIDENCE OF TAMPERING OR DISASSEMBLY?

YES  NO  N/A

IF YES, EXPLAIN

CHECK ENTIRE UNDERBODY FOR HIDDEN DAMAGE INCLUDING FRONT AND REAR SUSPENSION COMPONENTS

- UNDERBODY DAMAGED?

YES  NO

IF YES, EXPLAIN

PHOTOGRAPH REQUIRED

**PART D - SEATS/SHOULDER BELTS**

**REQUIRED PHOTOGRAPHS:**

- OVERALL SEAT BELTS I/B & O/B
- CLOSE UP OF ANY IRREGULARITIES
- LATCHPLATE WEAR
- CLOSE UP D-RING TO SHOW LOADING
- OVERALL OF SEAT
- CLOSE UP OF DAMAGE
- RECORD DTC'S:

**INFORMATION:**

- LOCATE SEAT BELT LABELS AND RECORD ALL INFORMATION (SOME LABELS ARE SEWN TO WEBBING, OTHER LABELS ARE ON THE RETRACTOR FRAME: INBOARD SEAT BELT LABELS ARE NEAR THE FLOOR):

**n/a**

- RECORD ALL INFORMATION STAMPED ON LATCHPLATE

**PP5660654B LS PP6156774B RS**

- PRETENSION DEPLOYED?

YES  NO  UNKNOWN

- EXISTING LOCATION OF RECLINER -

DESCRIBE THE LOCATION AND PICTURE OF SEAT BACK WITH B

PILLOR AS REFERENCE AND INCLINOMETER READING

**15 DEGREES REARWARD**

EXISTING LOCATION OF HEAD RESTRAINT (MEASURE GAP UNDER HEAD RESTRAINT):

**1.5 INCHES**

IF ALLOWED. FUNCTION BELTS TO INSURE THEY **FUNCTION PROPERLY**

NOTE RESULTS

- DOES THE BUCKLE LATCH?

YES  NO

IF NO, EXPLAIN

- DO THEY RELEASE?

YES  NO

IF NO, EXPLAIN

- DO THEY RETRACT?

YES  NO

IF NO, EXPLAIN

- ANY LOOSENESS OR BROKEN PARTS

YES  NO

IF YES, EXPLAIN?

- CHECK FOR SEAT RETAINING BOLTS

NORMAL

BROKEN

LOOSE

MISSING

NOTE AND RECORD APPROX. SEAT TRACK OVERLAP

**1 INCH REARWARD TOP TO BOTTOM TRACK**

**PART E - TRANSMISSION**

**REQUIRED****PHOTOGRAPHS:**

- ENTIRE TRANSMISSION WITH PICTURES AND CLOSE-UP OF LEAKS, IF ANY
- SHIFT LEVER AND CABLE AT TRANSMISSION-GEAR SHIFT LEVER
- SHIFT INDICATOR WITH LEVER IN EACH GATED GEAR POSITION.
- SHOW INDICATOR ALIGNMENT
- PHOTO SHIFT LINKAGE ADJUSTMENT CONNECTOR

**INFORMATION:**

- TEST SHIFT INTERLOCK OPERATION
- TEST KEY INTERLOCK FUNCTION
- TEST NEUTRAL START INTERLOCK
- CLUTCH AND LINKAGE INSPECTION
- FLUID LEVEL AND CONDITION

**INFORMATION:**

- TRANSMISSION TYPE?  
 MANUAL  AUTOMATIC
- HOW MANY SPEEDS?  
 3  4  5  6
- TRANSMISSION IDENTIFICATION NUMBER:  
**3T3071525KL103T**
- RECORD GEAR SHIFT POSITION AT TIME OF INSPECTION:  
PARK
- RUN SHIFT LEVER THRU ALL SHIFT POSITIONS AND RECORD "FEEL OF GATING":  
**NO ABNORMALITIES**

- DOES THE PARKING BRAKE WORK?  
 YES  NO  
IF NO, EXPLAIN
- IS SHIFT INDICATOR PROPERLY ALIGNED AT ALL GATES?  
 YES  NO  
IF NO, EXPLAIN
- SHIFT TYPE  
 COLUMN  CENTER CONSOLE
- IF SAFE AND PERMITTED TO DRIVE:  
DRIVE VEHICLE AND RECORD FEEL OF GEAR DURING EACH SHIFT:  
**NO ABNORMALITIES**
- DOES PARKING PAWL ENGAGE?  
 YES  NO  
IF NO, EXPLAIN
- IF LOCKUP IS ALLEGED - CHECK ROTATION OF TRANSMISSION IN ALL GEARS  
**NO LOCKUP**  
DOES THE VEHICLE START IN PARK AND NEUTRAL  
 YES  NO  
DOES THE VEHICLE START IN OTHER POSITIONS  
 YES  NO  
IF YES, EXPLAIN
- IS VEHICLE EQUIPPED WITH BTSI  
 YES  NO  
IF YES, EXPLAIN  
**EQUIPPED**  
IF EQUIPPED WITH BTSI CAN YOU SHIFT OUT OF "P" WITHOUT DEPRESSING SERVICE BRAKE  
 YES  NO  
IF YES, EXPLAIN
- DOES KEY ROTATE TO "LOCK" WITH SHIFT LEVER IN ANY POSITION OTHER THAN PARK.  
 YES  NO  
IF YES, EXPLAIN  
**PUSH BUTTON START**  
CAN KEY BE REMOVED FROM IGNITION IN ANY POSITION OTHER THAN PARK  
 YES  NO  
IF YES, IS KEY OEM OR AFTERMARKET  
 OEM  AFTERMARKET  N/A  
WITH KEY OUT CAN SHIFT LEVER BE MOVED FROM "PARK"?  
 YES  NO  
IF YES, EXPLAIN

Previous

Next

**PART F - UNINTENDED ACCELERATION****REQUIRED****PHOTOGRAPHS:**

AT FIRST ARRIVAL  
WHAT WAS POSITION  
OF CC POWER  
SWITCH

ON  OFF

N/A

AT FIRST ARRIVAL  
RECORD WHETHER  
BATTERY IS  
CONNECTED OR  
CHARGED

CONNECTED/  
CHARGED

DISCONNECTED

CONNECTED/  
DEAD

ACCELERATOR PEDAL

THROTTLE

RETURN SPRING

FLOOR MATS

BRAKE PEDAL -

COMBINATION  
ACCELERATOR/BRAKE

PCM

PCM CONNECTOR'S

SPEED CONTROL

SERVO - (CABLE)

SPEED CONTROL

SERVO -

(ELECTRICAL

CONNECTORS)

THROTTLE CABLES

CRUISE CONTROL

VACUUM RESERVOIR

CRUISE CONTROL

VACUUM HOSES

COMPLETE PART G

**INFORMATION:**

DESCRIBE ANY ACCELERATOR PEDAL  
INTERFERENCE WITH THE  
FLOORMAT/CARPETING

**NO INTERFERENCE**

READ AND RECORD ENGINE AND  
CRUISE CONTROL DTC'S

**NONE**

DISCONNECT CABLE AT THROTTLE BODY  
LEVER

- OPERATE:  THROTTLE BODY  CABLE

- ANY RESTRICTED MOTION?:  YES  NO  
IF YES, EXPLAIN

IF SAFE AND PERMITTED TO DRIVE  
ATTEMPT TO DUPLICATE AND CHECK  
SERVICE BRAKES AT VARIOUS SPEEDS:

- DO SERVICE BRAKES OPERATE NORMALLY?

YES  NO

IF NOT, EXPLAIN

**PART G - BRAKES****REQUIRED****PHOTOGRAPHS:**

ITEMS IN  
INFORMATION  
SECTION

BRAKE PADS/SHOES

BRAKE  
ROTORS/DRUMS

BRAKE CALIPERS

MASTER CYLINDER  
CONNECTIONS

VACUUM BOOSTER

HYDRAULIC LINKS

ABS MODULE  
CONNECTORS

ABS SERVO

BRAKE PEDAL

BRAKE PEDAL  
CONNECTORS

PARKING BRAKES

PARK BRAKE  
CABLES

**INFORMATION:**

CHECK AND RECORD BRAKE FLUID LEVEL:

**FULL**

OBSERVE AND RECORD IF VACUUM  
BOOSTER HOSE IS CONNECTED

YES  NO

CHECK AND RECORD BRAKE FLUID LEAKS

YES  NO

IF YES, EXPLAIN **NO LEAKS**

CHECK LININGS AND RECORD CONDITION

IF YES, EXPLAIN **FRONT 13/32'S REAR  
10/32'S LINING REMAINING**

CHECK BRAKE PEDAL DOES IT SET FIRM?

YES  NO

IF NO, EXPLAIN

CHECK OPERATION OF PARKING BRAKE:

**HOLDS VEHICLE**

CHECK OPERATION OF ABS SYSTEM:

**OPERATIONAL**

ADDITIONAL OBSERVATIONS

WITH ENGINE OFF:

APPLY BRAKE FULLY 3 TO 4 TIMES

WITH LIGHT FORCE HELD TO PEDAL,  
START THE ENGINE

- NOTE REACTION OF PEDAL AND RECORD

**HOLDS FIRM**

NO ABS SYSTEM AVAILABLE

ABS SYSTEM DRB TEST READOUTS

**NONE**

NOT "RWAL" EQUIPPED

IF "RWAL" EQUIPPED, RECORD FLASH  
CODES:

**NONE**

**INFORMATION**

- RACE ENGINE WITH VEHICLE IN DRIVE AND BRAKES APPLIED

**PART H - STEERING/SUSPENSION/TIRES**

**REQUIRED PHOTOGRAPHS:**

- COMPLETE STEERING SYSTEM
- RACK & PINION
- LINKAGE
- C/V & UNIVERSAL JOINTS
- COLUMN
- BELTS & PULLEYS
- STEERING GEAR
- EACH TIRE WITH VISIBLE LOCATION LABEL, INSURING ALL TIRE IDENTIFICATION AND TREAD WEAR IS DOCUMENTED
- ALL DAMAGED WHEEL AND RIM AREA INCLUDING IMPACTED FOREIGN MATERIAL

**INFORMATION:**

- STEERING TYPE?  MANUAL  POWER
- CHECK AND RECORD FLUID LEVEL: **FULL**
- RECORD COLOR OF FLUID: **GOOD**
- IS DRIVE BELT TIGHT?
  - YES  NO
  - IF NO, EXPLAIN
- CHECK FOR HOSE/SYSTEM LEAKS
  - YES  NO
  - IF YES, EXPLAIN **NO LEAKS**
- CHECK CONDITION OF STEERING LINKAGE FROM WHEELS TO STEERING COLUMN. RECORD INFORMATION OR LOOSE CONNECTIONS **NO ABNORMALITIES**

- UNLOCK KEY AND TURN WHEEL FULLY RIGHT TO LEFT

**OPERATES SMOOTHLY**

- IF SAFE, START ENGINE AND TURN WHEEL FULLY RIGHT TO LEFT AND LIST OBSERVATIONS

**NO ABNORMALITIES**

- ADDITIONAL OBSERVATIONS

RECORD:	FRONT LEFT	FRONT RIGHT	REAR LEFT	REAR RIGHT	SPARE
TIRE SIZE:	245/45R20	245/45R20	245/45R20	245/45R20	
BRAND:	FIRESTONE	CONTINENTAL		FIRESTONE	
	other :	other :	other :	other :	other :
RATING:	99V	99V	99V	99V	
DOT NO.:	W208BTO3111	W208BTO3111	W208BTO3111	W208BTO3111	
TREAD DEPTH	9/32'S	9/32'S	9/32'S	9/32'S	
PRESSURE:	35.9PSI	36.2PSI	35.3PSI	35.6PSI	

**PART I - AXLE/DIFFERENTIAL**

**REQUIRED PHOTOGRAPHS:**

- ENTIRE AXLE AND CLOSE UP OF LEAKS

**INFORMATION:**

- VEHICLE ON HOIST:
- REAR WHEEL DRIVE:
- RECORD AMOUNT OF LATERAL AXLE MOVEMENT OF EACH SIDE AND WILL WHEELS TURN: **NONE**
- TRANS. AXLE - ROTATE WHEELS
- NOTE FUNCTION:

**PART J - ADDITIONAL COMMENTS (DO NOT DRAW ANY CONCLUSIONS)**

Vehicle inspection, exterior damage only to the front bumper cover. No underbody or interior damage. Airbags did not deploy, seat belt(s) pretensioners did not activate. No personal injury to driver or occupant. Brake system inspected and tested. Vehicle does have aftermarket accessory all weather floor mats installed. No obstructions to accelerator pedal. Parking brake holds vehicle. This vehicle is equipped with 8 speed auto 8hp45 transmission. Electronic shift by wire gear shift selector. This vehicle is equipped with push button start and remote starter system. The engine will only start when the gear shift is in park position. You can not start the engine in any other gear or turn off the engine in any other gear, you can only turn the engine off in park position. This vehicle had 2 DTC`s stored in the ESM module U175-00 & P1C86-14.

Previous

Form Approved

Returned for corrections































DODGE



DODGE







## **⚠ WARNING**

### **EVEN WITH ADVANCED AIRBAGS**

- CHILDREN CAN BE KILLED OR SERIOUSLY INJURED BY THE AIRBAG.
- THE BACK SEAT IS THE SAFEST PLACE FOR CHILDREN.
- NEVER PUT A REAR-FACING CHILD SEAT IN THE FRONT.
- ALWAYS USE SEATBELTS AND CHILD RESTRAINTS.
- SEE OWNER'S MANUAL FOR MORE INFORMATION ABOUT AIRBAGS.



05108 114AA

## **⚠ MISE EN GARDE**

### **MÊME AVEC DES SACS GONFLABLES PARFAITS**

- LES ENFANTS PEUVENT ÊTRE TUÉS OU GRAVEMENT BLESSÉS PAR UN SAC GONFLABLE.
- LA BANQUETTE ARRIÈRE EST LA PLACE LA PLUS SÛRE POUR LES ENFANTS.
- NE JAMAIS PLACER UN SIÈGE POUR ENFANT ORIENTÉ VERS L'ARRIÈRE À L'AVANT DU VÉHICULE.
- TOUJOURS UTILISER LES CEINTURES DE SÉCURITÉ ET LES SYSTÈMES DE RETENUE POUR ENFANT.
- CONSULTER LE GUIDE DE L'AUTOMOBILISTE POUR OBTENIR PLUS DE RENSEIGNEMENTS SUR LES SACS GONFLABLES.

**⚠ WARNING**

**EVEN WITH ADVANCED AIRBAGS**

- CHILDREN CAN BE KILLED OR SERIOUSLY INJURED BY THE AIRBAG.
- THE BACK SEAT IS THE SAFEST PLACE FOR CHILDREN.
- NEVER PUT A REAR-FACING CHILD SEAT IN THE FRONT.
- ALWAYS USE SEATBELTS AND CHILD RESTRAINTS.
- SEE OWNER'S MANUAL FOR MORE INFORMATION ABOUT AIRBAGS.

05108114AA



**⚠ MISE EN GARDE**

**MÊME AVEC DES SACS GONFLABLES PER**

- LES ENFANTS PEUVENT ÊTRE TUÉS OU GRAVEMENT BLESSÉS PAR UN SAC GONFLABLE.
- LA BANQUETTE ARRIÈRE EST LA PLACE LA PLUS SÛRE POUR LES ENFANTS.
- NE JAMAIS PLACER UN SIÈGE POUR ENFANT ORIENTÉ VERS L'ARRIÈRE À L'AVANT DU VÉHICULE.
- TOUJOURS UTILISER LES CEINTURES DE SÉCURITÉ ET LES PROTECTEURS DE RETENUE POUR ENFANT.
- CONSULTER LE GUIDE DE SÉCURITÉ POUR PLUS D'INFORMATIONS SUR LES SACS GONFLABLES.













RFE

PP 6156774 B



RF













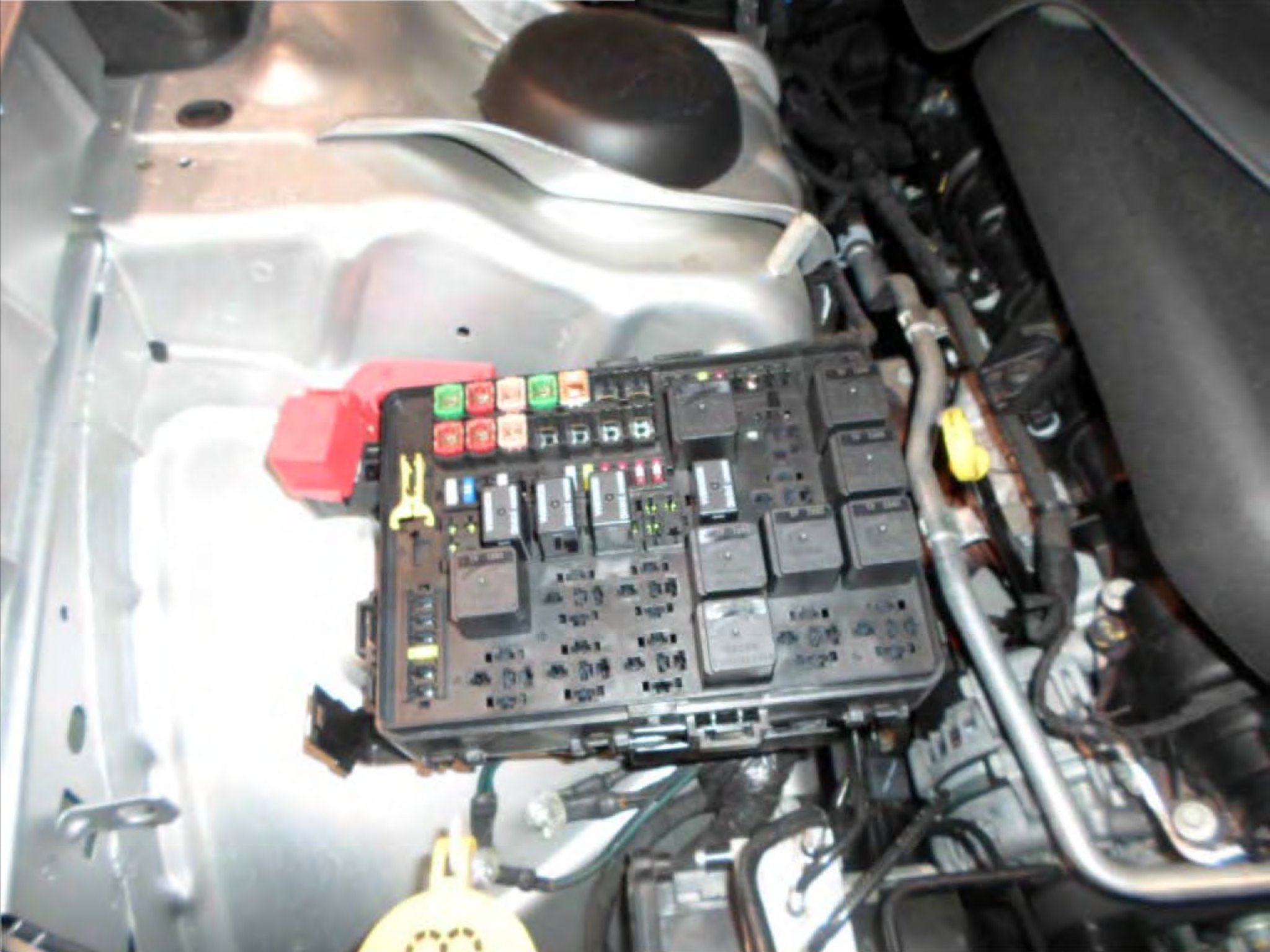









012











959200









USE ONLY CHRYSLER 8-SPEED TRANS FLUID 5285A2B3  
PER SERVICE MANUAL. USE CHRYSLER TOOL TO DETERMINE  
TRANS FLUID TEMPERATURE.  
ONLY CHECK FILL LEVEL AT FLUID TEMP 66-122°F (19-50°C).  
OTHERWISE DO NOT OPEN!



110718980592900001260080

# FLOOR SHIFT

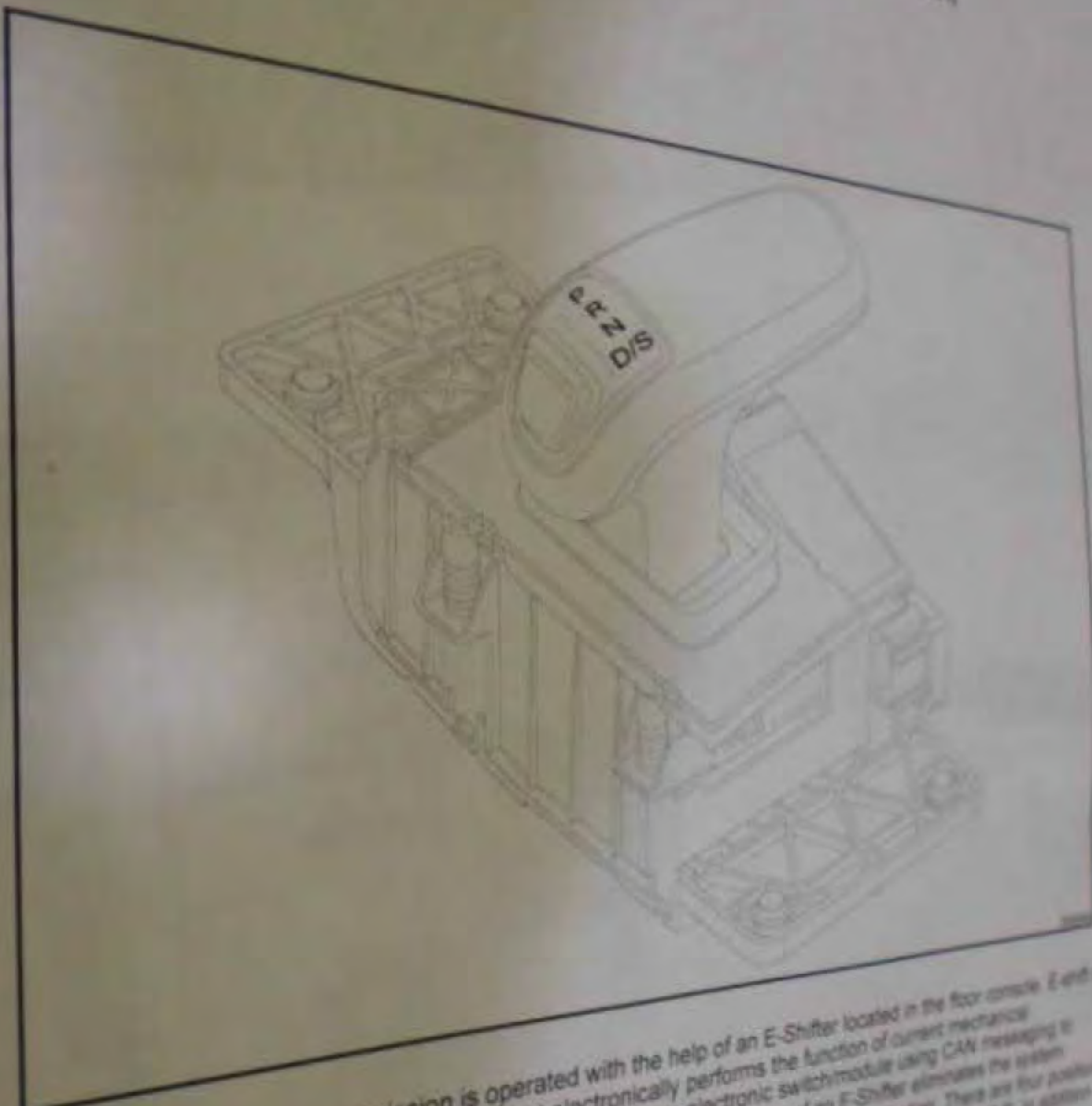

The 8HP45 automatic transmission is operated with the help of an E-Shifter located in the floor console. E-shift is "Shift by Wire" is a vehicle level system that electronically performs the function of current mechanical shifter/linkage/transmission hardware. The E-Shifter is an electronic switch/module using CAN messaging to communicate driver requests for transmission gear changes. The use of an E-Shifter eliminates the system linkage & mechanical connection to transmission park pawl & sprag for normal operation. There are four positions to which the selection lever can be shifted: P, R, N, D/L. With the Sport option package P, R, N, D/S in addition the Sport option package integrates paddle shifters at the steering wheel with allows the operator to manually chose gears as long as they comply with engine speed parameters.



1/2" DIA  
1/2" WT. 3.0000.000  
11/27/11



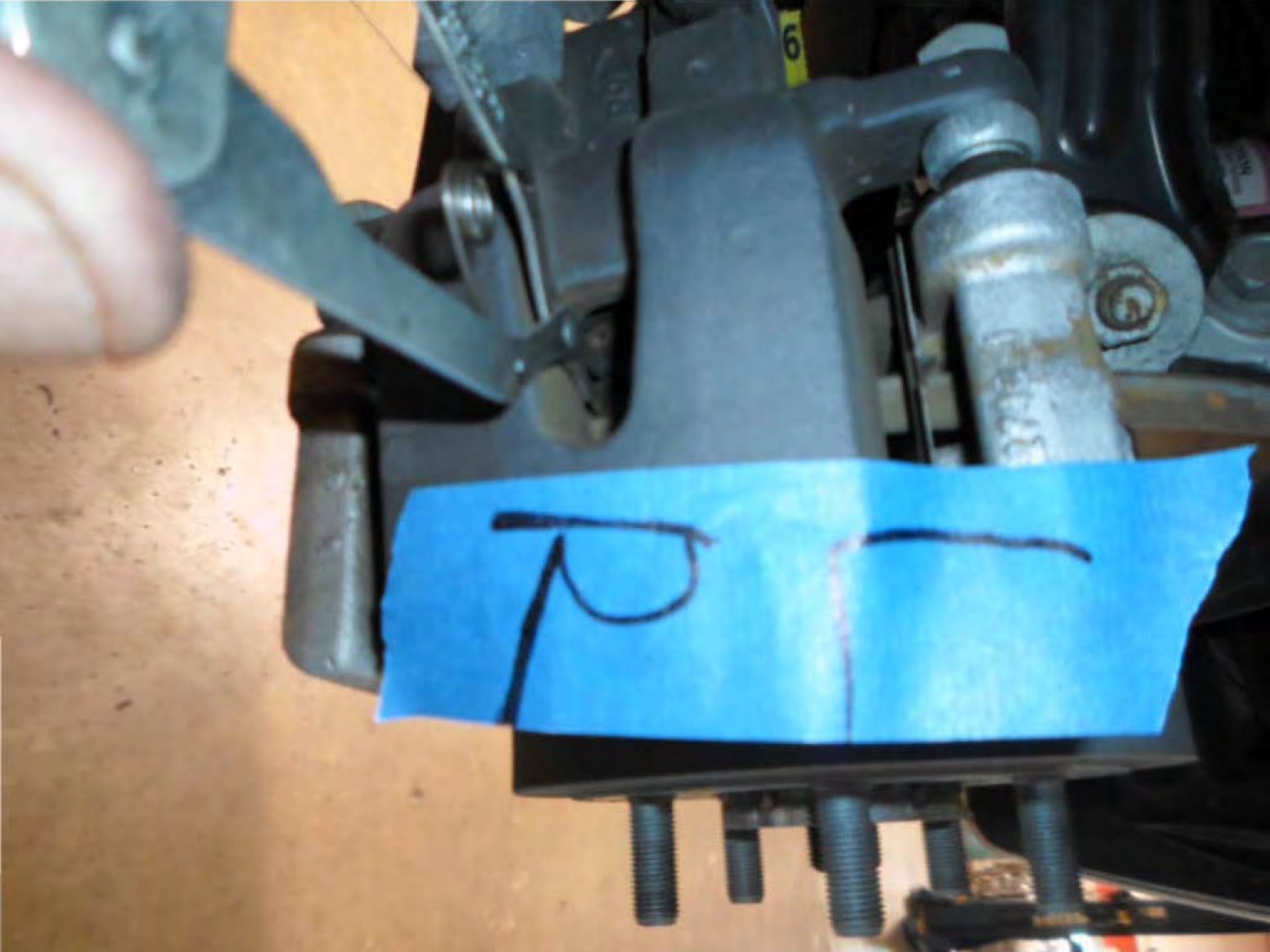

R

6

# Vehicle View

Full view on ECU for the full system. Click on an ECU for complete details.

2012 LD 3.6L  
VIN 2C3CD9H2C  
Battery 12.02 volts

- Legend
- Active ECU
  - Non-responsive ECU
  - DTCs Present
  - ECU Not Built
  - Scanning ECU
  - New Flash Available
  - CAN-C
  - CAN-HS

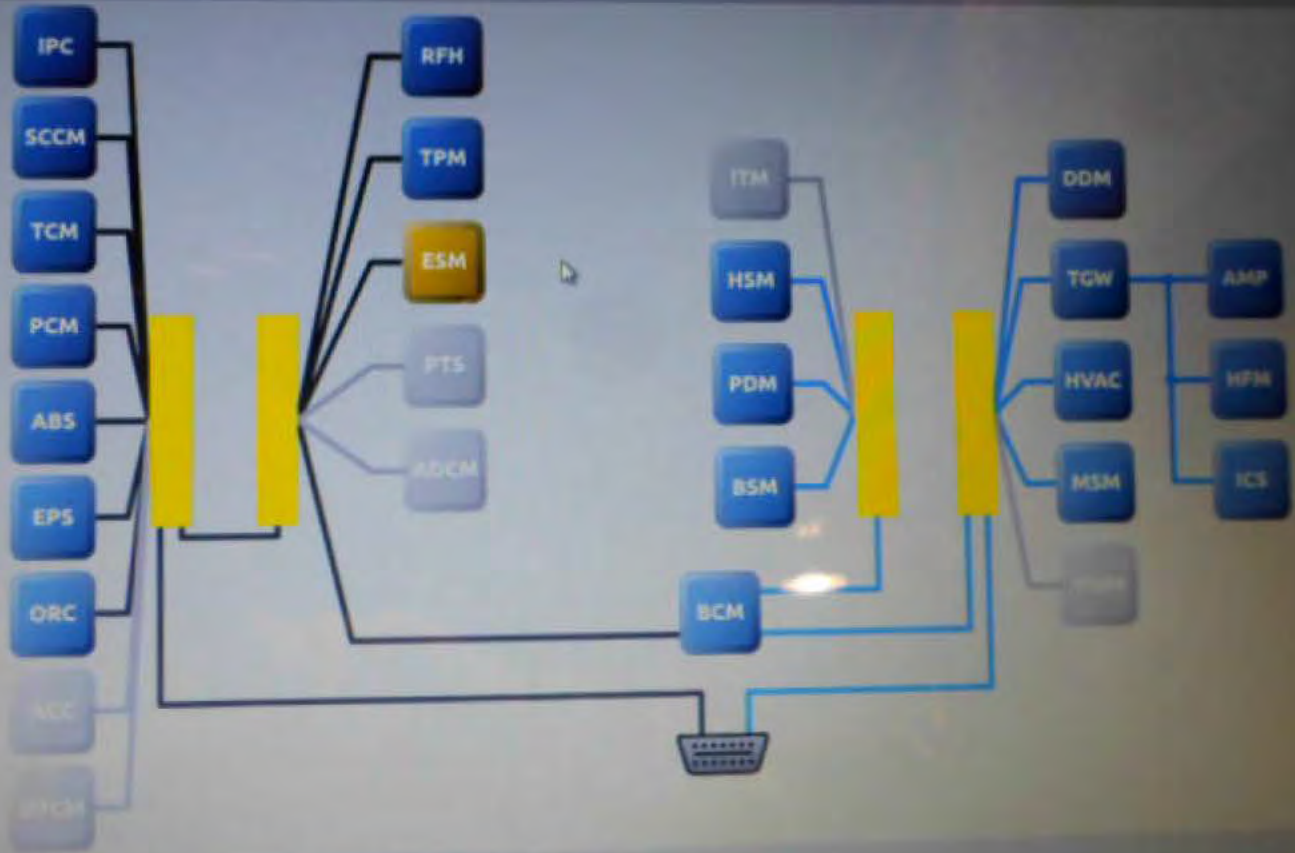

There are several knowledge base articles available below



# Vehicle View

Full view on ECU's see full items. Click on an ECU for complete details.

2012 LD 3.6L  
VIN 2C3CDXHG2CH  
Battery 12.02 volts

- Legend
- Active ECU
  - Non-responsive ECU
  - DTCs Present
  - ECU Not Built
  - Scanning ECU
  - New Flash Available
  - CAN-C
  - CAN-BD

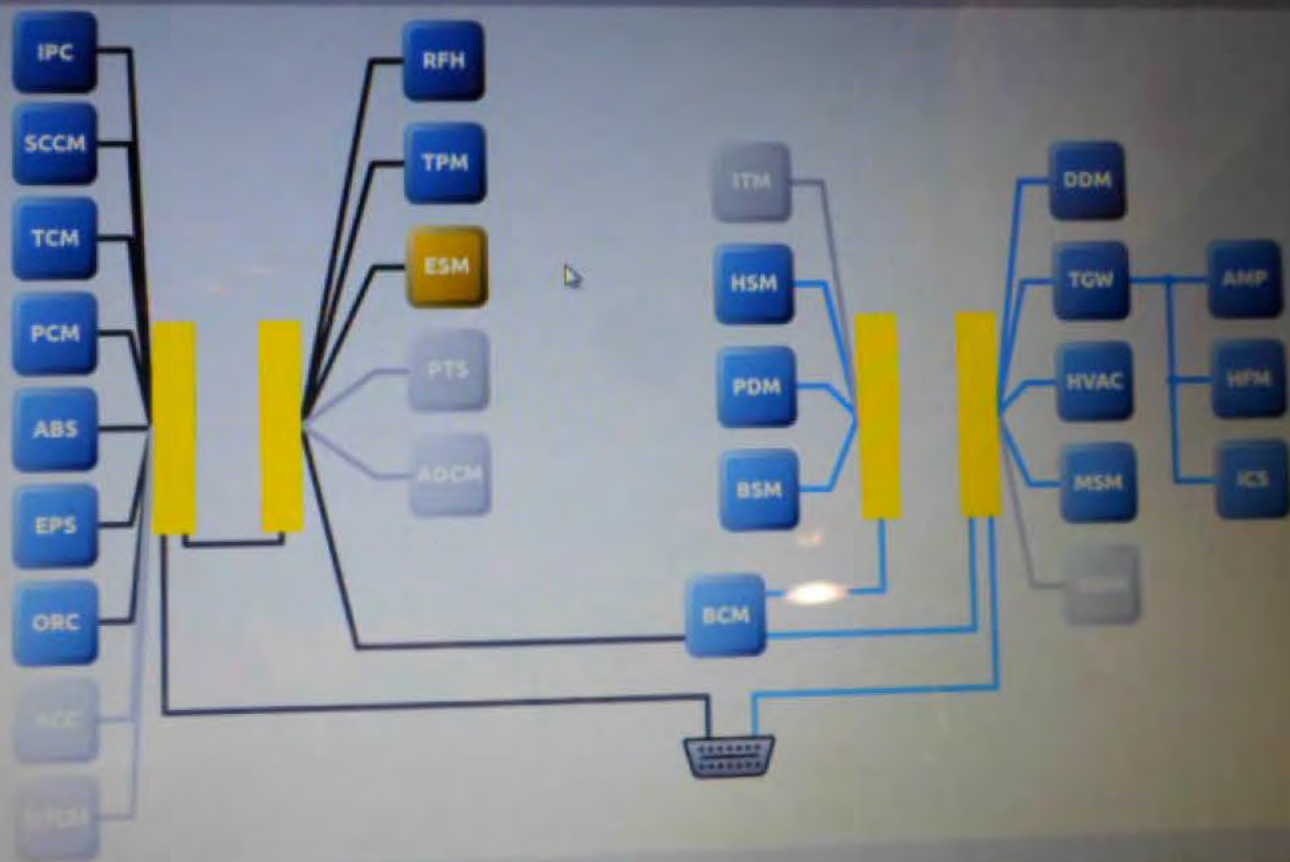

There are several knowledge items without available items.

# Vehicle View

Click on an ECU to see full name. Click on an ECU for complete details.

2012 LD 3.4L  
VIN: 2C3CDXHG2CH [REDACTED]

- Legend
- Active ECU
  - Non-responsive ECU
  - DTCs Present
  - ECU Not Built
  - Scanning ECU
  - New Flash Available
  - CAN-C
  - CAN-HS

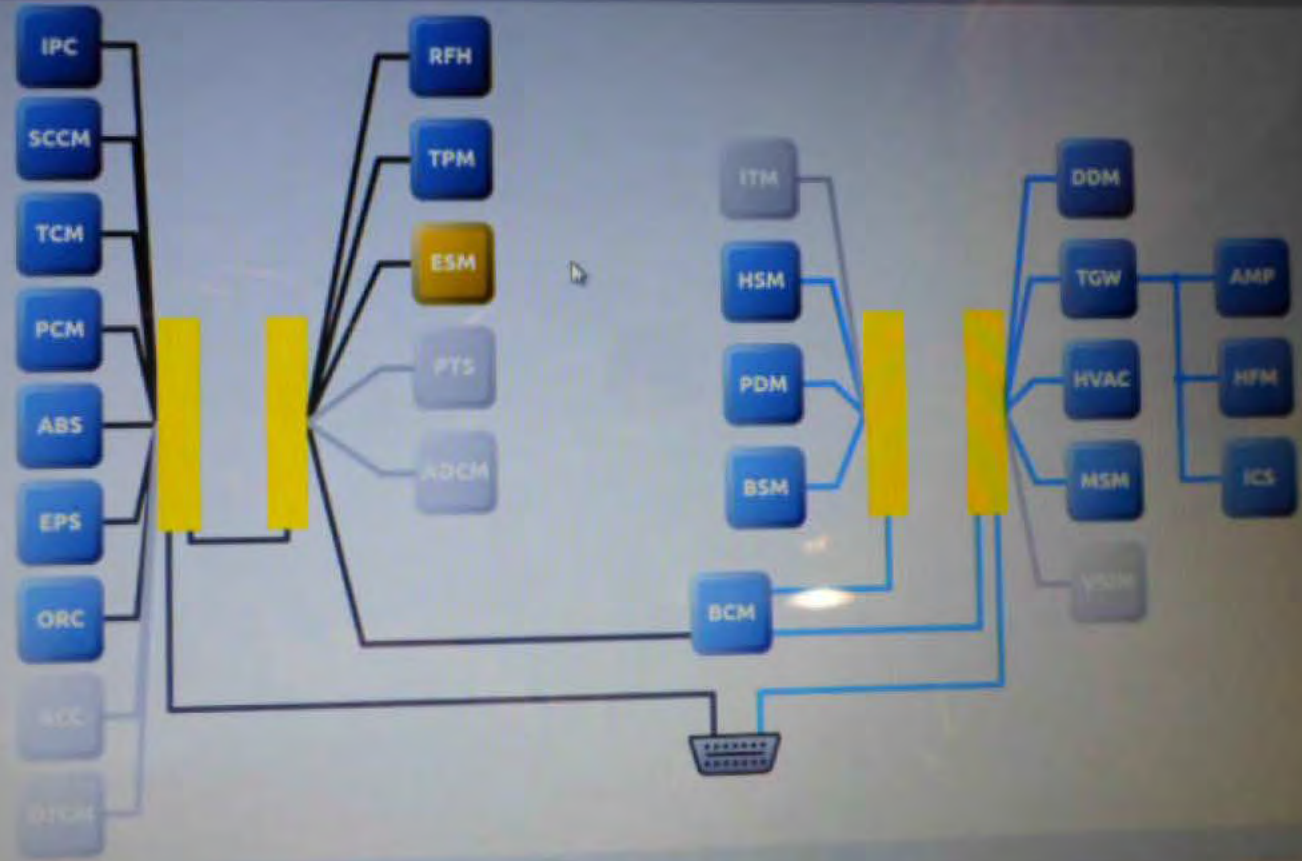

There are several unread messages in your inbox. Click here to view them.





# View

Access various ECU operations and information for the selected ECU.

- Flash
- Data
- DTCs**
- Actuators
- System Tests
- Misc Functions
- ECU Details

Double-click row selection to view environmental data. Click on column heading to sort table.

All Active Stored Pending

View Freeze Frame  View Data List

ECU	Code	Status	Description
ESM	U1175-00	Stored	Lost Ignition Status Message
ESM	P1C86-14	Stored	PRNDL Display-Circuit Short to Ground or Open

# ECM View

View or write various ECU operations and information for the selected ECU.

- Flash
- Data
- DTCs
- Actuators
- System Tests
- Misc Functions
- ECU Details**

Click on the buttons to view the desired information. Click on column heading to sort table.

Name	Value
Hardware Part Number	68140727AA
ECU Part Number	68140727AD
HW - year	11
HW - week	23
HW - patch level	00
SW - year	11
SW - week	47
SW - patch level	5
Model Year	2012
Vehicle Line	LD
Body Style	4-Door Sedan
Country Code	USA
ECU Serial Number	TU129110022
ECU File Name	ESM/ESM_394/42
ECU Database ID	6231





# TCM View

Click on tabs to access various ECU operations and information for the selected ECU.

- Flash
- Data
- DTCs
- Actuators
- System Tests
- Misc Functions
- ECU Details

Click on the buttons to view the desired information. Click on column heading to sort table.

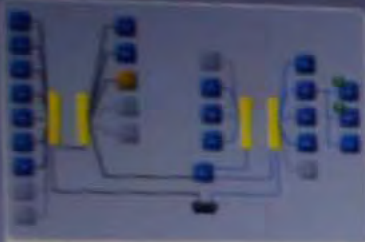

## Overview

### Transmission Control Module

Flash Part Number:

68046526AL

Bus Type:

CAN C

Hardware Version:

0A.03.1F

Software Version:

#0: 12.26.00, #1: 12.26.00

Spare Part Number:

Not Available

ISO Code:

Software Number:

Not Available

Hardware Number:

Not Available

Original VIN

2C3CDXHG20

Current VIN

2C3CDXHG20

Variant & Version:

40-06

Country Code

N/A

DTC Count:

0

Name	Value
Active Diagnostic Variant	40
Active Diagnostic Version	6
ECU Part Number	68046526AL
HW - year	0A
HW - week	3
HW - patch level	1F
VIN Original	2C3CDXHG20
VIN Current	2C3CDXHG20
ECU File Name	TCM/TCM/01
ECU Database ID	6344

# ORC View

Click on tabs to access various ECU operations and information for the selected ECU

- Flash
- Data
- DTCs
- Actuators
- System Tests
- Misc Functions
- ECU Details

Click on the buttons to view the desired information. Click on column heading to sort table.

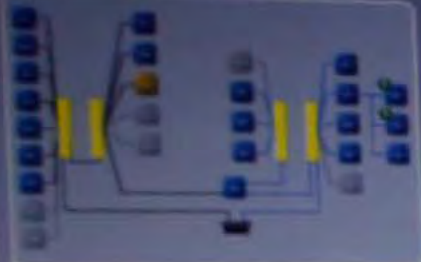

### Overview

Occupant Restraint  
Flash Part Number:  
56054077A1  
Bus Type:  
CAN C  
Hardware Version:  
08.08.00  
Software Version:  
#0: 11.11.00, #1: 11.19.29, #2: 00.00.00  
Spare Part Number:  
Not Available  
ISO Code:  
  
Software Number:  
Not Available  
Hardware Number:  
Not Available  
Original VIN [REDACTED]  
Current VIN [REDACTED]  
Variant & Version:  
40-05  
Country Code  
USA  
DTC Count:

Name	Value
Original VIN	2C3CD3HG2[REDACTED]
Current VIN	2C3CD3HG2[REDACTED]
Model Year	2012
Vehicle Line	Rest Initia201
Body Style	4-Door Sedan
Country Code	USA
ECU Serial Number	T12MG229101431
Chrysler ECU Identification: ECU Part Number	56054077A1
Sw Version Year for Logical Block 0	11
Sw Version Week for Logical Block 0	11
Sw Version Patch Level for Logical Block 0	0
Sw Version Year for Logical Block 1	11
Sw Version Week for Logical Block 1	19
Sw Version Patch Level for Logical Block 1	29
Sw Version Year for Logical Block 2	0
Sw Version Week for Logical Block 2	0
Sw Version Patch Level for Logical Block 2	0
Software Supplier for Logical Block 0	Bosch
Software Supplier for Logical Block 1	Bosch
Hardware Supplier	Bosch
Diagnostic Variant	40



# PCM View

Click on tabs to access various ECU operations and information for the selected ECU.

- Flash
- Data
- DTCs
- Actuators
- System Tests
- Misc Functions
- ECU Details

Click on the buttons to view the desired information. Click on column heading to sort table.



**Overview**

Powertrain Control Module

**Flash Part Number:**  
68078633AH

**Bus Type:**  
CAN C

**Hardware Version:**  
12.47

**Software Version:**  
11.02.00

**Spare Part Number:**  
Not Available

**ISO Code:**

**Software Number:**  
Not Available

**Hardware Number:**  
Not Available

**Original VIN:** [REDACTED]

**Current VIN:** [REDACTED]

**Variant & Version:**  
23 - A8

**Country Code:**  
USA

**DTC Count:**

Name	Value
Model Year	2017
ECU Part Number	68078633AH
Body Style	4-Door Sedan
Vehicle Line	29
VIN - Original	2C3CD8HG2CH [REDACTED]
VIN - Current	2C3CD8HG2CH [REDACTED]
Software Version (Major/Middle/Minor)	11.02.00
Hardware Version (Major/Minor)	12.47
Serial Number	108848214308
Supplier ID	Motorola
Diagnostic Version	44
Variant ID	23
Country Code	USA
ECU File Name	PCM078633
ECU Database ID	6300

1 2 A



# BCM View

Click on tabs to access various ECU operations and information for the selected ECU.

- Flash
- Data
- DTCs
- Actuators
- System Tests
- Misc Functions
- ECU Details**

Click on the buttons to view the desired information. Click on column heading to sort table.



Overview

name:

Body Controller

Flash Part Number:  
68154473AB

Bus Type:  
CAN C

Hardware Version:  
GA\_14.00

Software Version:  
#0: 11.23.01

Spare Part Number:  
Not Available

ISO Code:

Software Number:  
Not Available

Hardware Number:  
Not Available

Original VIN [REDACTED]  
2C3CD9HG2CH

Current VIN [REDACTED]  
2C3CD9HG2Y

Variant & Version:  
40-08

Country Code  
USA

DTC Count:

Name	Value
Model Year	2013
Vehicle Line	LD
Body Style	4-Door Sedan
Country Code	USA
ECU Part Number	68154473AB
Hardware Part Number	68154473AB
Software Logical Block #0 Part Number	68154473AB
VIN Current	2C3CD9HG [REDACTED]
VIN Original	40 [REDACTED]
Active Diagnostic Variant	08
Active Diagnostic Version	10
HW - year	20
HW - week	8
HW - patch level	11
SW - year	23
SW - week	1
SW - patch level	10
Boot SW - Year	20
Boot SW - Week	8
Boot SW - Patch Level	11
Hardware Supplier Identification	2C3CD9HG



# ABS View

Click on tabs to access various ECU operations and information for the selected ECU.

- Flash
- Data
- DTCs
- Actuators
- System Tests
- Misc Functions
- ECU Details

Click on the buttons to view the desired information. Click on column heading to sort table.



## Overview

name:  
Anti Lock Brakes  
Flash Part Number:  
04779737AC  
Bus Type:  
CAN C  
Hardware Version:  
08.04.4A  
Software Version:  
80-11.14.71  
Spare Part Number:  
Not Available  
ISO Code:  
  
Software Number:  
Not Available  
Hardware Number:  
Not Available  
Original VIN  
2C3CDRHG2C3 [REDACTED]  
Current VIN  
2C3CDRHG2C3 [REDACTED]  
Variant & Version:  
40-00  
Country Code  
N/A  
DTC Count:

Name	Value
Active Diagnostic Variant	40
Active Diagnostic Version	5
Hardware Part Number	04779737AC
Software Part Number	8019030AC
ECU Part Number	04779737AC
HW - year	08
HW - week	4
HW - patch level	40
SW - year	11
SW - week	14
SW - patch level	71
ECU Serial Number	782010K7 [REDACTED]
VIN Original	2C3CDRHG [REDACTED]
VIN Current	2C3CDRHG [REDACTED]
ECU File Name	ABSABS_Pump
ECU Database ID	430



# ESM View

Click on tabs to access various ECU operations and information for the selected ECU

- Flash
- Data
- DTCs
- Actuators
- System Tests
- Misc Functions
- ECU Details

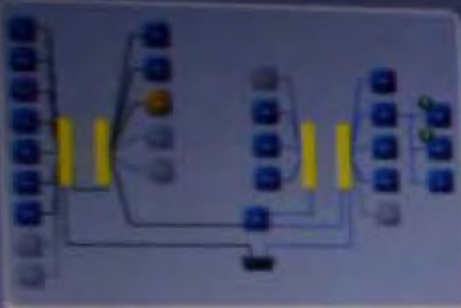

## Overview

Electronic Shifter  
**Flash Part Number:**  
 68140727AD  
**Bus Type:**  
 CAN C  
**Hardware Version:**  
 08.17.00  
**Software Version:**  
 #0: 11.47.00, #1: 11.47.00  
**Spare Part Number:**  
 Not Available  
**ISO Code:**  
  
**Software Number:**  
 Not Available  
**Hardware Number:**  
 Not Available  
**Original VIN**  
 Invalid  
**Current VIN**  
 Invalid  
**Variant & Version:**  
 22-01  
**Country Code**  
 null  
**DTC Count:**

Click on the buttons to view the desired information. Click on column heading to sort table

Name	Value
Hardware Part Number	68140727AD
ECU Part Number	68140727AD
HW - year	08
HW - week	39
HW - patch level	00
SW - year	11
SW - week	47
SW - patch level	00
Model Year	2012
Vehicle Line	4-Door Sedan
Body Style	4DR
Country Code	USA
ECU Serial Number	XXXXXXXXXX
ECU File Name	XXXXXXXXXX
ECU Database ID	XXXX

https://www.connect.com/.../.../...

fastSearchResults.jsp

File Edit View Favorites Tools Help

Page Safety Tools

### Service Information

#### U1175-00-LOST IGNITION STATUS MESSAGE

28 - DTC-Based Diagnostics / MODULE, Electronic Shift (ESM), 8HP70 / Diagnosis and Testing

#### U1175-00-LOST IGNITION STATUS MESSAGE

28 - DTC-Based Diagnostics / MODULE, Steering Control (SCM) / Diagnosis and Testing

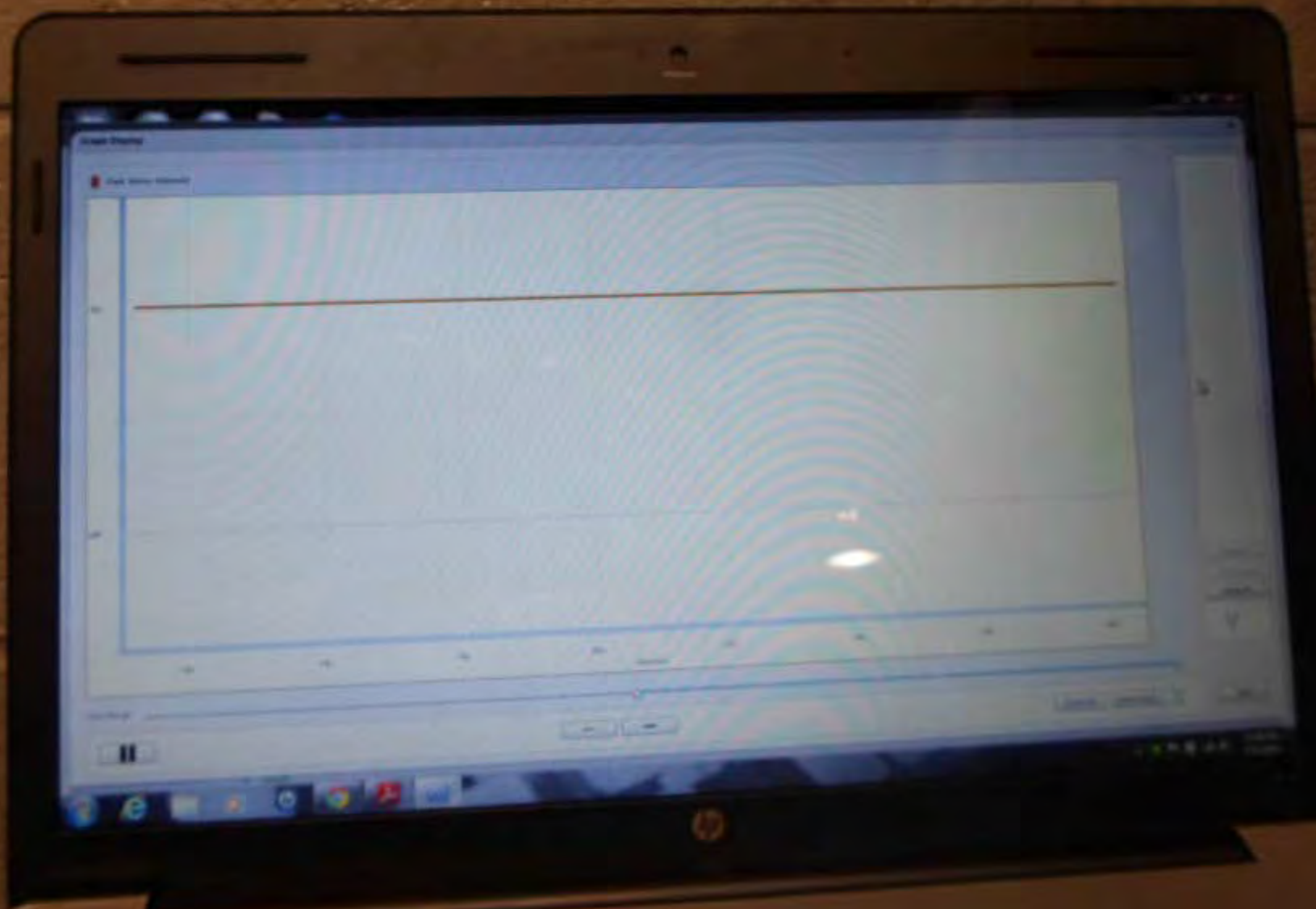

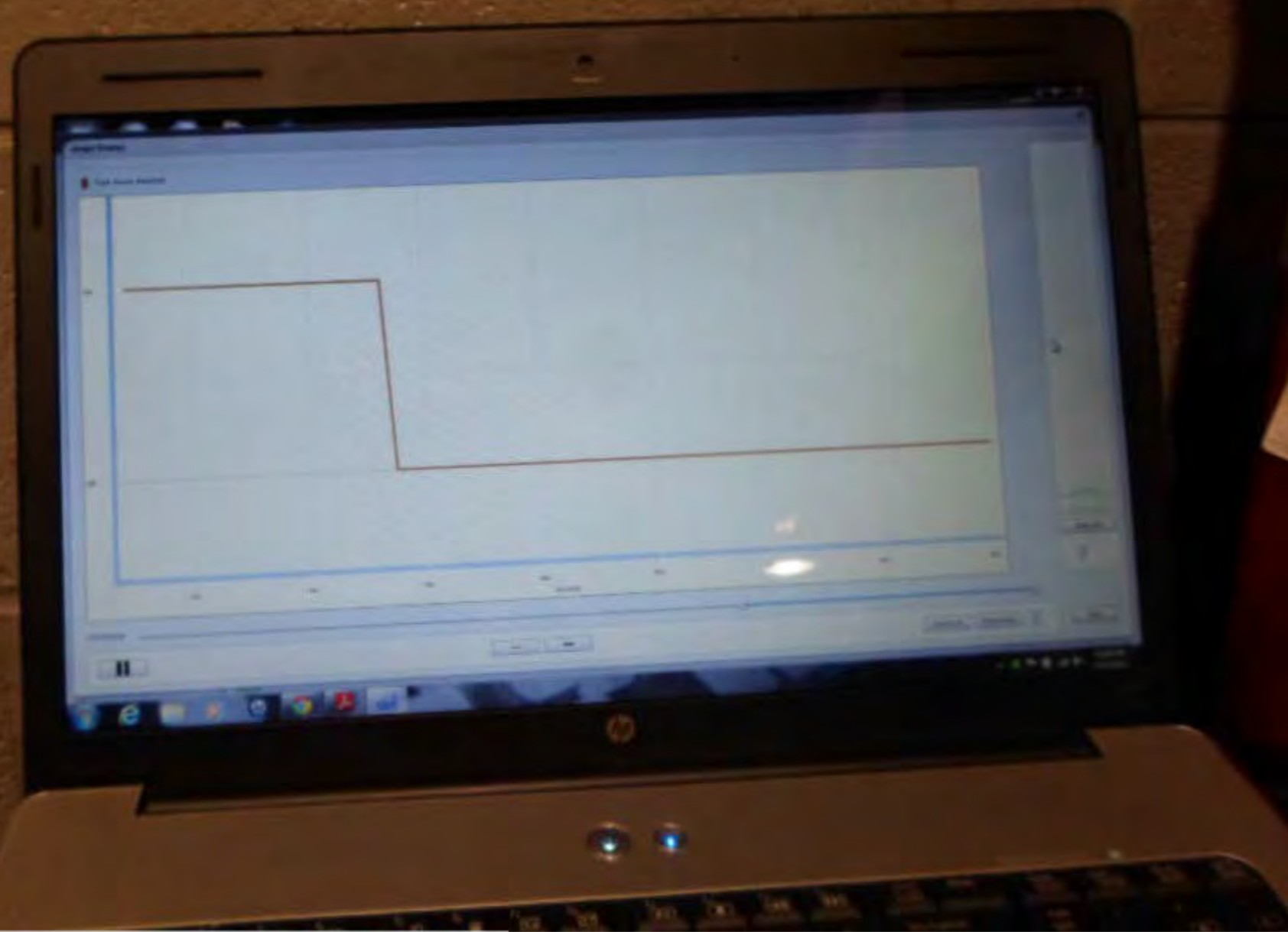

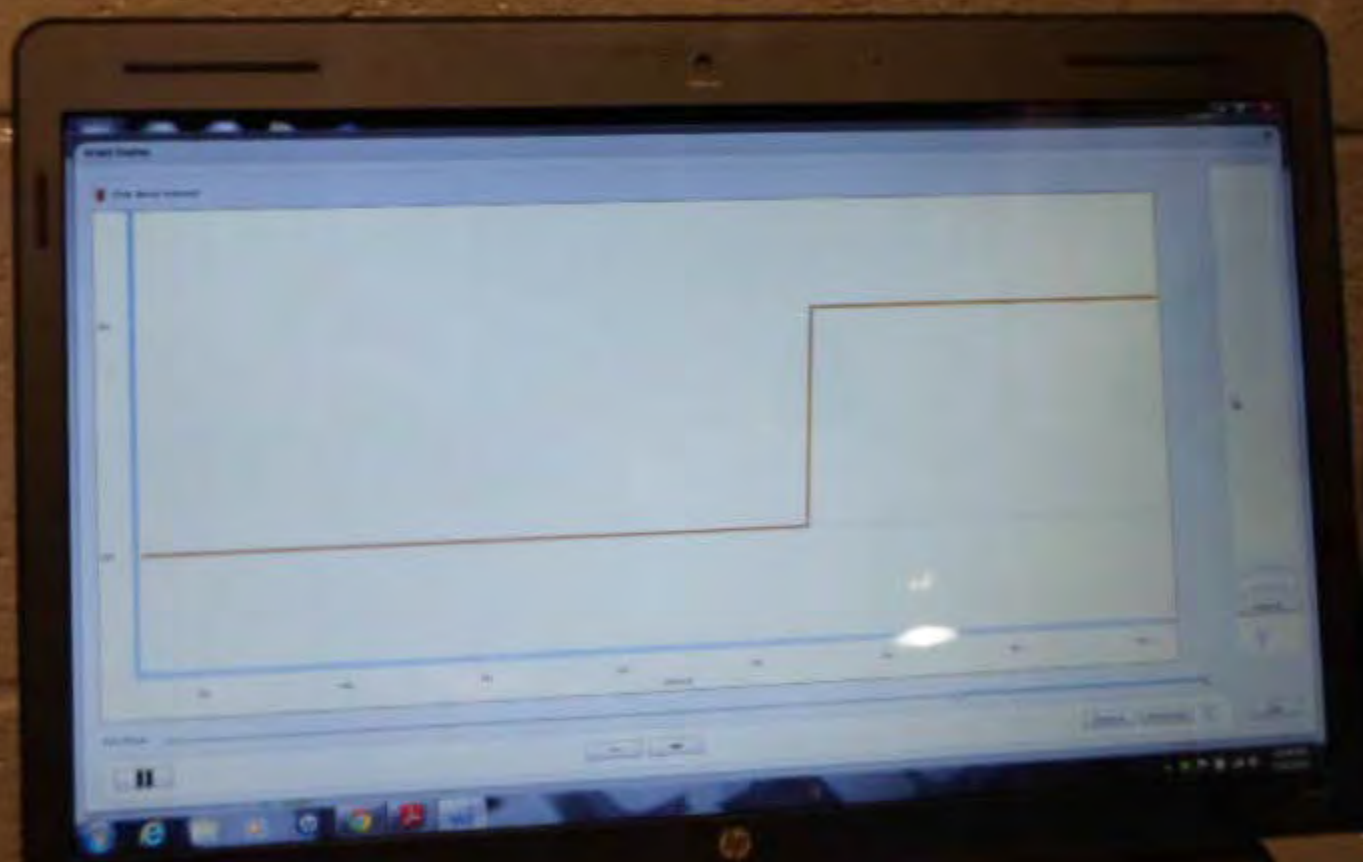

STUDENT ID: 123456789  
NAME: [Name]  
[Other text]



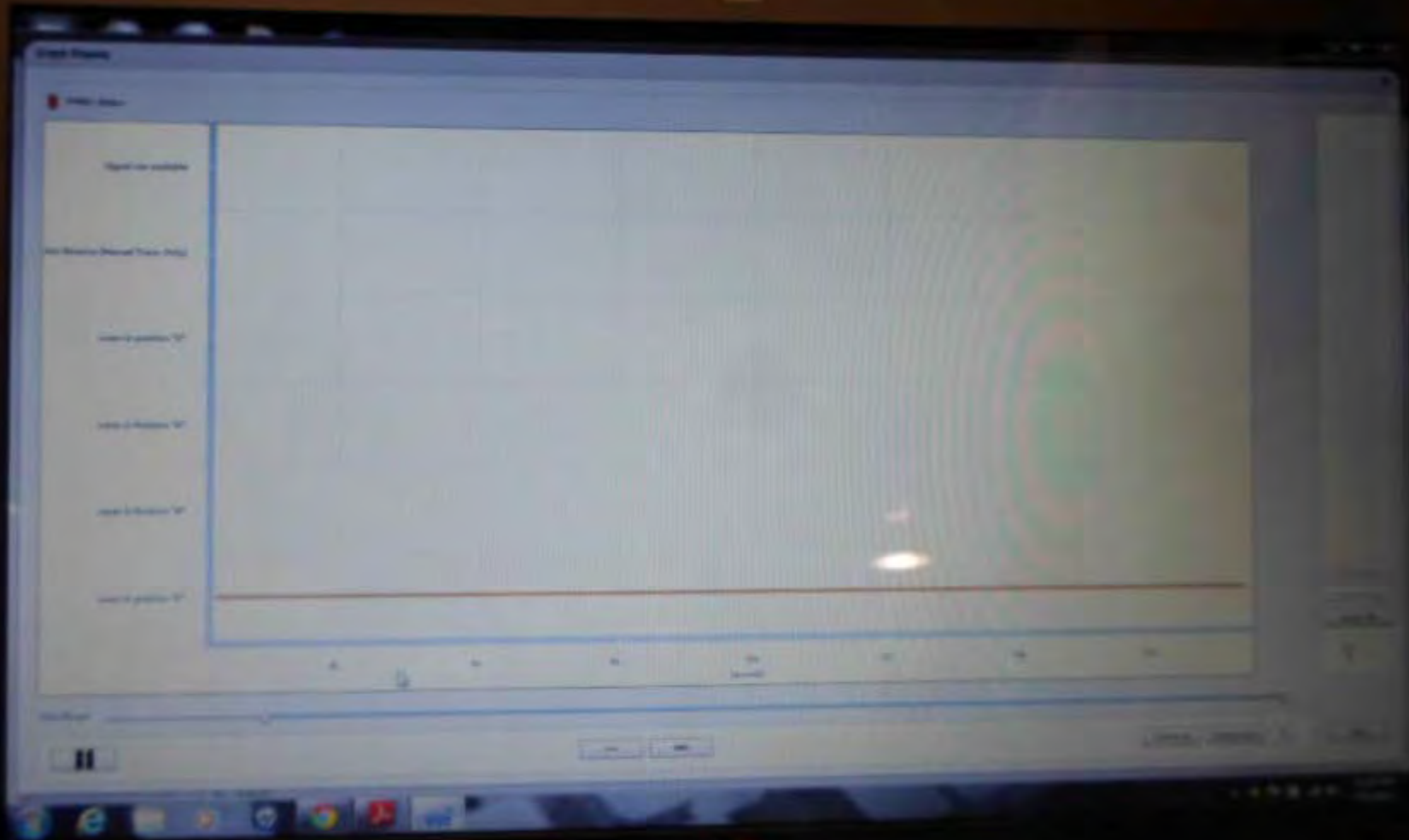



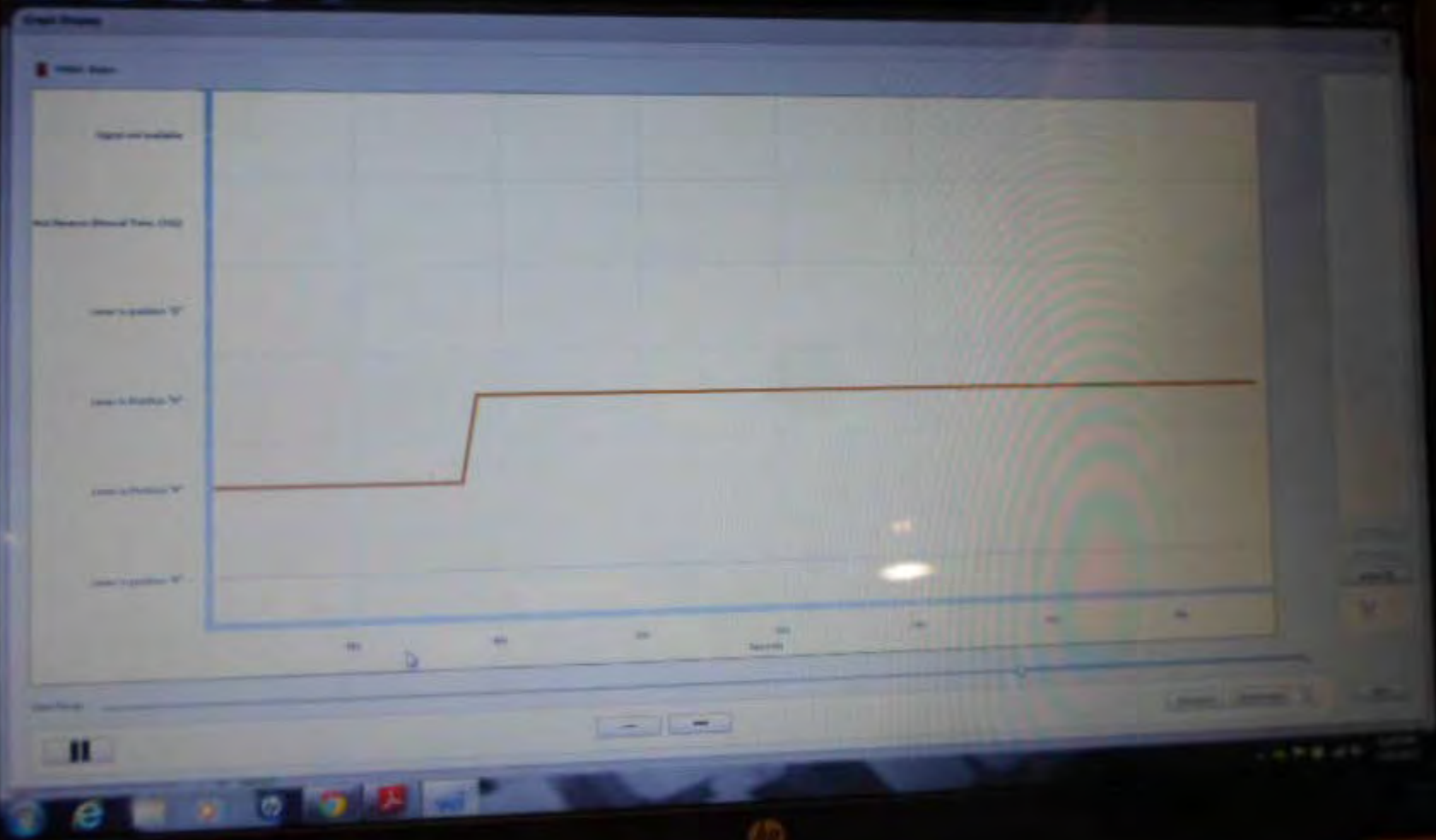

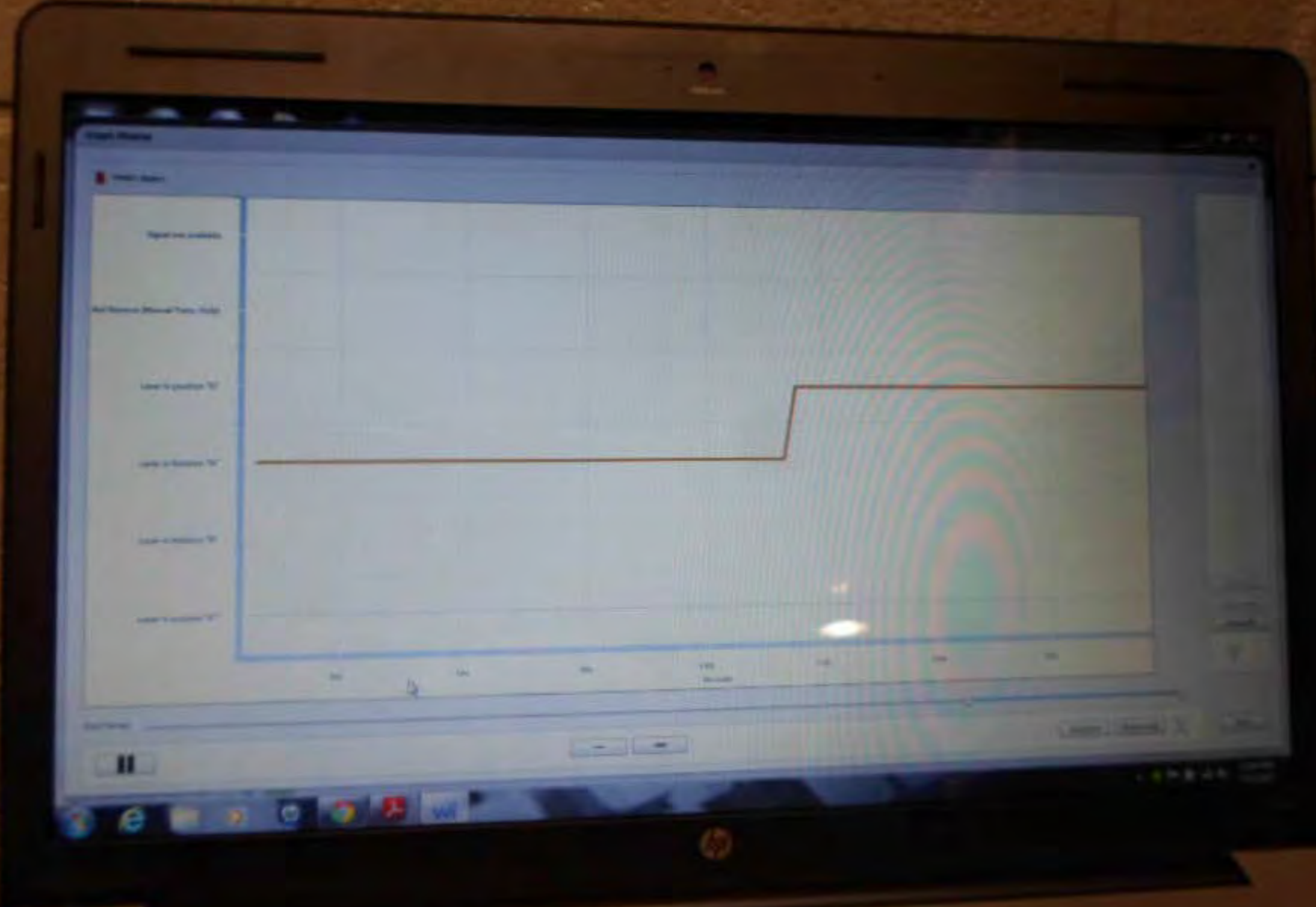





GH154371

P68140727AC

140727AC



CHRYSLER CORPORATION

SUPPLIER 64481



ISSUE 1  
DATE CODE 2311  
SN

T U1 231 1 00222



3847mi

82°

Start Engine  
to Shift  
into Gear

P

R

N

D

S

3847mi

82°

Start Engine  
to Shift  
into Gear

P  
R  
N  
D  
S

MPH  
km/h

2C3CDXHG2CH

MFD BY **CHRYSLER GROUP LLC**

GWR: 02314 KG

05100 LB

GWR: 01275 KG

FRONT: 02810 LB

DATE OF MFR: 10-11

GWR: 01275 KG

REAR: 02810 LB

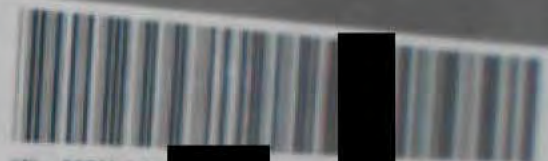

THIS VEHICLE CONFORMS TO ALL APPLICABLE U.S.A. FEDERAL MOTOR VEHICLE SAFETY,  
BUMPER AND THEFT PREVENTION STANDARDS IN EFFECT ON  
THE DATE OF MANUFACTURE SHOWN ABOVE.

VIN: 2C3CDXHG2

MDH: 102400 60400

VEHICLE MADE IN CANADA

PAINT: REE

TRM: CLR



VIN: 2C3CDXHG2CH [REDACTED]

TYPE: PASSENGER

MDH: 102408 664AA

PAINT: PS2

TRIM: CLY9

VEHICLE MADE IN CANADA

4658













LF



LF





LF



LF



LF



AIRBAG

RF

RFE





RT



RR



TT 70



775









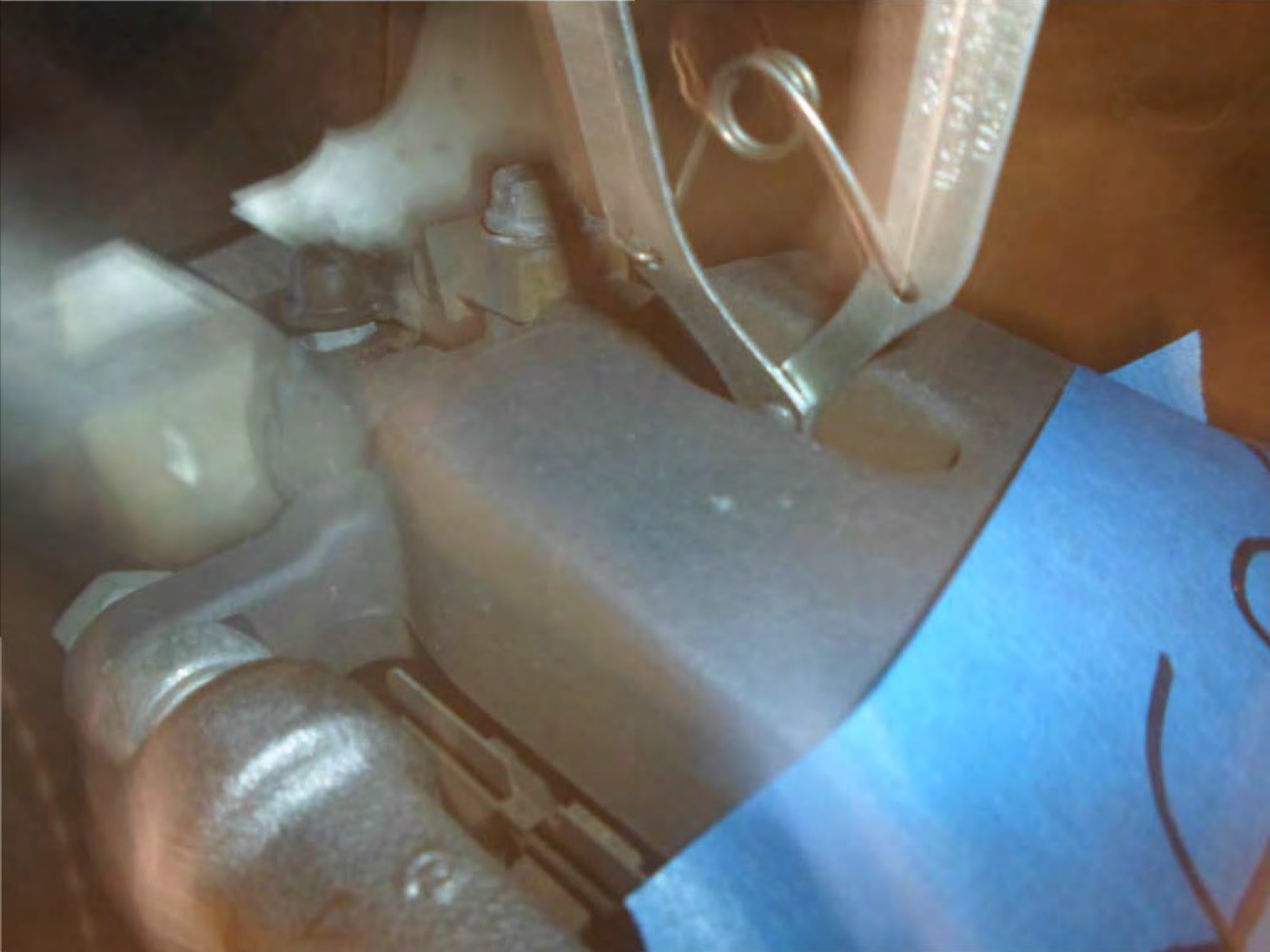





DEGREES

MLR-10326-2

MADE IN USA

NO. 798

DEGREES



MLR-10326-2

MADE IN USA

DEGREE

EA16-002

FLAT CHRYSLER

5-12-2016

ENCLOSURE 04

CAIR Backup

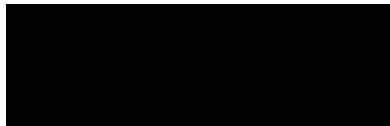

Job/User : T5631MA  
 Report Name : ZGRFI\_GAP\_CANCEL\_PAY  
 Source Area : SU - SU - C.A.I.R. United States

Page #: 1  
 Date : 12/10/2013  
 Time : 09:23:53

PAYMENT	ORIGINAL	VENDOR			PAYMENT	VOID	VOID	NEW CHECK # /	
MTHD	CURR	PYMT #	ID	VENDOR NAME	VENDOR ADDRESS	AMOUNT	DATE	CODE	REVERSAL DOCUMENT #
C	USD	0008920884	SU00000001	MR ABHIJEET A VELASKAR	9100 WESTHEIMER RD #337 HOUSTON TX 77063-355U	1,935.97-	12/05/2013	17	NO REISSUE - 23500949
C	USD	0008932524	SU00000001	MRS SUSAN NICHOLS	1 COLE LN SANTA FE NM 87508-598US	619.79-	12/05/2013	17	NO REISSUE - 23983434
C	USD	0008936609	SU00000001	MR KYTTLE KYTTLE	10 RAILROAD AVE MADISON CT 08443-312US	568.55-	12/05/2013	17	NO REISSUE - 23912192
C	USD	0008954965	SU00000001	MR SHANNON BRYANT	7726 HWY 165 COLUMBIA LA 71418 US	735.12-	12/05/2013	17	NO REISSUE - 23805120
C	USD	0008965674	SU00000001	MISS LISETTE LOPEZ	17230 NW 77TH CT HIALEAH FL 33015-381US	325.76-	12/05/2013	17	NO REISSUE - 24010682
C	USD	0008969914	SU00000001	MR CALE IORG	4152 CLARK HILL CT BUFORD GA 30519-371US	66.57-	12/06/2013	17	NO REISSUE - 24142347
C	USD	0008973113	SU00000002	CHRYSLER FINANCIAL	SUITE 213 NORCROSS GA 30092 US	16,694.72-	12/05/2013	17	NO REISSUE

\*\*\*\*\* Total for source SU in USD: 20,946.48-

\*\*\*\*\* Number of invoices ==> 7

\*\*\*\*\* TOTAL OF ALL SOURCE AREAS FOR USD: 20,946.48-

\*\*\*\*\* TOTAL NUMBER OF INVOICES: 7

**Document Recieved from Customer**

**Cair Number:** [REDACTED]

**Date Received: 2013-10-09 14:20:46.047271**

**Files Not Recieved: 0**



FACSIMILE TRANSMITTAL SHEET

△ HAVEN NURSING CENTER, INC.  
TELEPHONE (318) 649-9800 EXT. \_\_\_\_\_  
FAX (318) 649-9875 OR (318) 649-9825

△ HAVEN REHABILITATION CENTER, INC  
TELEPHONE (318) 649-9826 EXT. \_\_\_\_\_  
FAX (318) 649-9827

To: Kekey Clay FROM: 318-649-9813  
FAX: 1-868-849-3869 PAGES (INCLUDING COVER SHEET): 2  
PHONE: DATE: 10-06-13  
RE: CC:

△ URGENT △ PLEASE VERIFY RECEIPT (SEE BELOW) △ PLEASE COMMENT △ PLEASE REPLY △ FOR REVIEW

Comments: IS this what you needed sorry it took so long my wife got it for me.

NOTICE REGARDING CONFIDENTIAL INFORMATION

THIS FAX TRANSMITTAL AND ANY ATTACHMENTS ARE FOR THE SOLE USE OF THE INTENDED RECIPIENT AND MAY CONTAIN PROPRIETARY, CONFIDENTIAL, TRADE SECRET, OR PRIVILEGED INFORMATION, BELONGING TO THE SENDER, THAT IS LEGALLY PRIVILEGED.

THE AUTHORIZED RECIPIENT OF THIS INFORMATION IS PROHIBITED FROM DISCLOSING THIS INFORMATION TO ANY OTHER PARTY AND IS REQUIRED TO DESTROY THE INFORMATION AFTER ITS STATED NEED HAS BEEN FULFILLED.

IF YOU ARE NOT THE INTENDED RECIPIENT, YOU ARE HEREBY NOTIFIED THAT ANY REVIEW, USE, DISCLOSURE, DISTRIBUTION OR ACTION TAKEN IN RELIANCE ON THE CONTENTS OF THESE DOCUMENTS IS STRICTLY PROHIBITED AND MAY BE A VIOLATION OF LAW. IF YOU HAVE RECEIVED THIS TRANSMISSION IN ERROR, PLEASE CONTACT THE SENDER TO ARRANGE FOR RETURN OF THESE DOCUMENTS.

**Open-End Disbursement  
 Receipt Plus**

BORROWER INFORMATION		
BORROWER 1 NAME	ACCOUNT NUMBER	DATE
		01/18/2013
BORROWER 2 NAME	PURPOSE: <input type="checkbox"/> FD	
	1 Year Old Vehicle Fixed Stan.	

SECURITY OFFERED					CONSUMERS' CLAIMS AND DEFENSES -- IF CHECKED, SEE NOTICE BELOW				
THE ADVANCE IS SECURED BY YOUR SHARES, ALL PROPERTY SECURING OTHER PLAN ADVANCES AND LOANS RECEIVED IN THE PAST OR IN THE FUTURE, AND THE FOLLOWING PROPERTY:									
PROPERTY/MODEL	YEAR	I.D. NUMBER	VALUE	KEY NUMBER					
2012 CHRYSLER 300		245523	MSRP 26825.00						

PLEDGE OF SHARES AND/OR DEPOSITS \$	ACCOUNT NUMBER	PLEDGE OF SHARES AND/OR DEPOSITS \$	ACCOUNT NUMBER

REPAYMENT TERMS						
DAILY PERIODIC RATE	ANNUAL PERCENTAGE RATE	MARGIN	OTHER FEES (Amount and Description)	PREVIOUS BALANCE		
0.0116154	4.24 %					
NEW BALANCE THIS SUBACCOUNT	AMOUNT ADVANCED	PAYMENT AMOUNT	DATE DUE	PAYMENT FREQUENCY	LINE OF CREDIT LIMIT	REMAINING LIMIT
\$ 24890.84	\$	\$ 735.12	03/03/2013	M	\$	\$

By endorsing the proceeds check for the advance described above, or by having the proceeds deposited into your share/share draft account or paid to a third party, you agree: (1) that the property described in the Security Offered section above ("Property") is security under the terms of the LOANLINER Credit and Security Agreement (the "Plan") for all amounts you owe under the Plan and that the property description is incorporated into and a part of the Plan; (2) that the Property is also security for any other loans, including but not limited to, any credit card account that you have with the credit union now or in the future; and (3) to make payments as disclosed above and in accordance with the terms of the Plan.

**CONSUMERS' CLAIMS AND DEFENSES NOTICE**

The following paragraph applies to the Advance only if the box is checked.

**NOTICE: ANY HOLDER OF THIS CONSUMER CREDIT CONTRACT IS SUBJECT TO ALL CLAIMS AND DEFENSES WHICH THE DEBTOR COULD ASSERT AGAINST THE SELLER OF GOODS OR SERVICES OBTAINED PURSUANT HERETO OR WITH THE PROCEEDS HEREOF. RECOVERY HEREUNDER BY THE DEBTOR SHALL NOT EXCEED AMOUNTS PAID BY THE DEBTOR HEREUNDER.**