

PE15-032

ISUZU

12-18-2015

ENCLOSURE 8 - 1

1 Owner's Manual

## Maintenance Schedule

Make sure the vehicle is inspected at regular intervals. Inspections and maintenance enable you to use the vehicle with peace of mind. They also extend the vehicle's service life.

For safe and economical driving, we recommend that you have your vehicle inspected and serviced regularly according to the schedule indicated in this chapter.

To drive your vehicle safely and at minimum cost, it is essential to have your vehicle regularly inspected and serviced at your Isuzu Dealer as per the specified maintenance schedule.

Contact your Isuzu Dealer for inspection that requires disassembly and/or special equipment.

The Maintenance Schedule in this manual and a Warranty Information Booklet are supplied with your vehicle. Read all publications for a full understanding of your vehicle's maintenance needs.

The quality of maintenance your new vehicle receives is as important as the regularity with which it is serviced. Isuzu, in cooperation with authorized dealers, provides nationwide quality in customer service. The program includes the training of dealer technicians throughout the country and is supported with a continuous follow-up of publications and other service information. The use of Isuzu genuine parts and accessories, which have the same high quality standards as original equipment parts, and the use of factory approved tools developed and tested for use by the authorized dealer also contribute to the high quality of service.

If you have any questions on how to keep your truck or chassis in good condition, see your authorized dealer, the place many Isuzu truck owners choose to have their maintenance work done. Your authorized dealer can be relied upon to use proper parts and practices.

Some of these services can be complex, so unless you are technically qualified and have the necessary equipment, you should let your authorized dealer's service department or another qualified service center do these jobs.

The schedule includes general maintenance which you or a qualified technician should perform periodically.

### Explanation of Vehicle Maintenance and Log

The following is a brief explanation of normal vehicle use.

**NORMAL VEHICLE USE**—The maintenance instructions contained in this section are based on the assumption that your vehicle will be used as designed:

- To carry passengers and cargo with the limitations indicated on the "Vehicle Certification and Greenhouse Gas (GHG) Emissions Plate".
- On reasonable road surfaces within legal operating limits.
- On a daily basis, as a general rule, for at least several miles/kilometers.

Unusual operating conditions, such as driving in dusty areas (sweeper, agricultural or off-road vehicles), extended idling (refrigeration vehicles), or vehicles operated for frequent short trips, will require more frequent vehicle maintenance.

The log groups items according to mile/kilometer service intervals. Use the item codes (letter and number) to find the description of the maintenance and the time intervals.

Follow whichever interval comes first, time or miles/kilometers.

After the maintenance services are performed, insert the month, day and mileage/kilometers in the area provided next to the serviced item.

The services shown up to 110,000 miles (176,000 km) are to be repeated after the initial 110,000 miles (176,000 km) at the same intervals.

## Preventive Maintenance

As any mechanical device operates, a certain amount of wear occurs. The amount of wear depends on certain variables – type and method of operation and the schedule of maintenance. These variables may be emphasized as critical to malfunction but each is dependent upon the other. For example, if a vehicle is repeatedly overloaded, driven at excessive speed or improperly shifted, no schedule of maintenance can prevent malfunction. Also, if a preventive maintenance schedule is not followed, or is improperly carried out, no amount of correct vehicle operation will prevent malfunction. If vehicle application, operation and preventive maintenance schedules and procedures are followed and properly carried out, the life of the vehicle will be greatly extended. For example, regular attention to the engine oil is essential. The oil level must be periodically checked and oil added whenever needed. Also, the oil should be changed at the intervals specified with the proper quality and viscosity of oil. If your engine should run excessively low on oil or if the oil has lost its lubricating qualities because of old age, serious engine damage could occur.

### Letters Used to Indicate Maintenance Service Types

- I : Inspect then clean, repair or replace as necessary
- A: Adjust
- R: Replace
- T: Tighten to the specified torque
- L: Lubricate
- C: Clean

**Maintenance Schedule (No. 1)**

I : Inspect then clean, repair or replace as necessary A: Adjust R: Replace  
T: Tighten to the specified torque L: Lubricate C: Clean

No.	Service interval	x1,000 km	16	24	32	48	64	72
		x1,000 miles	10	15	20	30	40	45
1	Engine noise check		I	-	I	I	I	-
2	Valve lash		-	-	-	-	-	-
3	Engine oil & oil filter <sup>2</sup>		R	-	R	R	R	-
4	Fuel filter		-	R	-	R	-	R
5	Pre-fuel filter/water separator		-	R	-	R	-	R
6	Air cleaner filter		-	-	-	-	-	-
7	Damage to air intake ducts and hoses		-	I	-	I	-	I
8	Drive belts		I	-	I	I	I	-
9	Engine bolt torques		-	-	-	-	-	-
10	Rotate tires							
11	Engine cooling system		I	-	I	I	I	-
12	Engine coolant							
13	Exhaust system		I	-	I	I	I	-
14	DPF (clean filter)		-	-	-	-	-	-
15	DPF (pressure difference sensor 0 point adjustment)		-	-	-	-	-	-
16	DPF (pressure difference sensor hose)							
17	Fuel line system		I	-	I	I	I	-
18	Brake lining and pad for wear		I	-	I	I	I	-
19	Brake drum and rotor for wear and damage		-	-	I	-	I	-
20	<input type="checkbox"/> Brake electric vacuum pump for NPR-HD/NPR-XD models		I	-	I	I	I	-
21	Brake fluid		I	-	I	R	I	-
22	<input type="checkbox"/> Hydraulic brake booster (HBB) fluid		-	-	-	R	-	-
23	Brake line and hoses		-	-	I	-	I	-
24	Parking brake cable		I	-	I	I	I	-
25	Automatic transmission fluid		I	-	I	R	I	-
26	<input type="checkbox"/> External automatic transmission filter		-	-	-	R	-	-
27	Differential gear oil		I	-	I	R	I	-
28	Power steering fluid		-	-	-	R	-	-

Remarks: <sup>1</sup> In case this column is blank, follow miles (kilometers).

<sup>2</sup> Use of oils other than CJ-4 may require shorter maintenance intervals and may cause nonconformity to regulations. Use of oils with other viscosity than \*W-40 may also require shorter maintenance intervals and may cause a problem with engine durability.

80	96	112	120	128	144	160	168	176	Service intervals months or miles (kilometers) whichever occurs first <sup>1</sup>
50	60	70	75	80	90	100	105	110	
I	I	I	-	I	I	I	-	I	
A	-	-	-	-	-	A	-	-	or every 12 months
R	R	R	-	R	R	R	-	R	or every 12 months
-	R	-	R	-	R	-	R	-	or every 24 months
-	R	-	R	-	R	-	R	-	or every 24 months
-	-	-	-	-	-	-	-	-	indicator <sup>3</sup>
-	I	-	I	-	I	-	I	-	or every 12 months
I	I	I	-	I	I	I	-	I	or every 12 months
I	-	-	-	-	-	I	-	-	
Every 6,500 miles (10,400 km)									
I	I	I	-	I	I	I	-	I	or every 12 months
Every 12 months: I Every 24 months: R (when Isuzu recommended coolant is used)									
I	I	I	-	I	I	I	-	I	
-	-	-	-	-	-	C	-	-	or every 3,000 hours
-	-	-	-	-	-	A	-	-	or every 3,000 hours
Every 100,000 miles (160,000 km): I Every 250,000 miles (400,000 km): R									
I	I	I	-	I	I	I	-	I	or every 3,000 hours: I
I	I	I	-	I	I	I	-	I	or every 12 months
-	I	-	-	I	-	I	-	I	or every 12 months
I	I	I	-	I	I	I	-	I	or every 12 months
I	R	I	-	I	R	I	-	I	or every 12 months: I or every 24 months: R
-	R	-	-	-	R	-	-	-	or every 24 months
-	I	-	-	I	-	I	-	-	or every 12 months
I	I	I	-	I	I	I	-	I	or every 12 months
I	R	I	-	I	R	I	-	I	or every 12 months
-	R	-	-	-	R	-	-	-	or every 24 months
I	R	I	-	I	R	I	-	I	or every 24 months
-	R	-	-	-	R	-	-	-	or every 24 months

Remarks: <sup>3</sup> Refer to "Air Cleaner Indicator Light" on page 2-24.

**Maintenance Schedule (No. 2)**

I : Inspect then clean, repair or replace as necessary A: Adjust R: Replace  
T: Tighten to the specified torque L: Lubricate C: Clean

No.	Service interval	x1,000 km	16	24	32	48	64	72
		x1,000 miles	10	15	20	30	40	45
29	Power steering oil hoses		-	-	-	-	-	-
30	Steering wheel free play <sup>4</sup>							
31	Steering gear box torque		-	-	T	-	T	-
32	Driveshaft flange torque		T	-	T	T	T	-
33	Driveshaft lubrication		L	-	L	L	L	-
34	Leaf spring U-bolt torque <sup>4</sup>		T	-	T	T	T	-
35	Wheel nut torque <sup>4</sup>							
36	King pin		L	-	L	L	L	-
37	Wheel bearing grease <sup>5</sup>		-	-	-	R	-	-
38	Air conditioner blower filter							
39	Exhaust injector							
40	DEF supply pump filter element							
41	Starter							

Remarks: <sup>\*1</sup> In case this column is blank, follow miles (kilometers).

<sup>\*4</sup> Initial check at 650 miles (1,040 km) is required.

<sup>\*5</sup> Be sure to discard used grease seal, and always use new grease seal for installation.

80	96	112	120	128	144	160	168	176	Service intervals months or miles (kilometers) whichever occurs first <sup>1</sup>
50	60	70	75	80	90	100	105	110	
R	-	-	-	-	-	R	-	-	or every 24 months
<b>Every 6,500 miles (10,400 km): I</b>									
-	T	-	-	T	-	T	-	-	or every 12 months
T	T	T	-	T	T	T	-	T	or every 12 months
L	L	L	-	L	L	L	-	L	or every 12 months
T	T	T	-	T	T	T	-	T	
<b>Every 6,500 miles (10,400 km)</b>									
L	L	L	-	L	L	L	-	L	or every 12 months
-	R	-	-	-	R	-	-	-	or every 24 months
<b>Cleaned once a month</b>									
<b>Cleaned every 110,000 miles (176,000 km)</b>									
<b>Every 120,000 miles (192,000 km): R</b>									or every 24 months
<b>When the starter indicator light (amber) comes on: R</b>									

### Explanation of Complete Vehicle Maintenance Schedule

The following is a brief explanation of each of the services listed in the preceding Complete Vehicle Maintenance Schedule.

1. Engine Noise — These components have an effect on the control of noise emissions.

Service interval	Maintenance procedure
Engine (Every 10,000 miles or 16,000 km)	Inspect sound absorption materials for tears, broken out sections or attachment. Repair or replace as necessary.
Cooling system (Every 10,000 miles or 16,000 km)	Inspect fan, shroud and radiator for attachment, tears or cleanliness. Repair or replace as necessary.
Air intake system (Every 15,000 miles or 24,000 km)	Inspect all ducts, hoses and intake silencers for leaks or chafing. Repair or replace as necessary.
Exhaust system (Every 10,000 miles or 16,000 km)	Inspect silencer, pipes, gaskets, clamps and mounting for exhaust gas leaks or looseness. Repair or replace as necessary.
Cab (Every 10,000 miles or 16,000 km)	Inspect sound absorption materials for tears, broken out sections or attachment. Repair or replace as necessary.

2. Valve Lash — Incorrect valve clearance will result in increased engine noise and lower engine output, thereby adversely affecting engine performance. Retorque rocker shaft bracket nuts before checking and adjusting valve clearance. Check and adjust valve clearance every 50,000 miles (80,000 km) or 12 months whichever occurs first.
3. Engine Oil and Oil Filter — Change at interval noted below depending upon driving conditions.
  - Normal Service — Change every 10,000 miles (16,000 km) or 12 months whichever occurs first.
  - Severe Service — Change every 5,000 miles (8,000 km) or 3 months if you often drive under one or more of these conditions: (a) driving in dusty areas, (b) frequent idling or idling for long periods, (c) driving 4 miles (6 km) or less in freezing weather, or other short trips in cold weather, where the engine does not thoroughly warm up. Change oil and filter as soon as you can after driving in a dust storm. When recommended oil is used, it conforms to this maintenance schedule. (Recommended oil: CJ-4 (API designations))
4. Fuel Filter — Replace the fuel filter every 15,000 miles (24,000 km) or more frequently if clogged, or replace when the fuel filter indicator light comes on.

5. **Pre-Fuel Filter/Water separator** — Replace the fuel filter every 15,000 miles (24,000 km) or more frequently if clogged, or replace when the fuel filter indicator light comes on.
6. **Air Cleaner Filter** — The level of dirt in the air cleaner element can be checked against the indicator.  
Replace the air cleaner filter when the multi-information display (MID) shows "CHECK AIR FILTER".
7. **Damage to Air Intake Ducts and Hoses** — Check if air cleaner hoses and ducts are connected and correctly installed every 15,000 miles (24,000 km) or 12 months.
8. **Drive Belts** — Check belt driving the fan, alternator or A/C compressor every 10,000 miles (16,000 km).  
Look for cracks, fraying, wear, and proper tension.
9. **Engine Bolt Torques** — Loosened bolts result in lower engine output.  
Check and adjust manifold mounting, and injectors to correct torque every 50,000 miles (80,000 km).

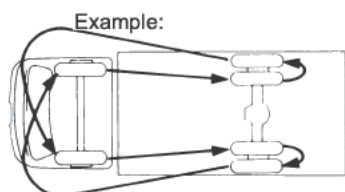

10. **Rotate Tires** — To equalize wear, rotate tires as shown in the figure and adjust tire pressures every 6,500 miles (10,400 km).

11. **Engine Cooling System** — At 12 months or 10,000 miles (16,000 km) intervals, wash radiator cap and filler neck with clean water, pressure test system and radiator cap for proper pressure holding capacity, tighten hose clamps and inspect condition of all cooling and heater hoses. Replace hoses if cracked, swollen or otherwise deteriorated. Have the hoses replaced by your authorized dealer.  
Also each 24 months, clean exterior of radiator core and charge air cooler.
12. **Engine Coolant** — Inspect the engine coolant every 12 months. Replace the engine coolant every 24 months, when Isuzu recommended coolant is used drain the engine coolant by opening the drain plug at the bottom of the radiator core, flush and refill the engine cooling system with a new engine coolant. Refer to "Preparing Engine Coolant" on page 5-49 in this section. Have the engine coolant replaced by your authorized dealer.
13. **Exhaust System** — Check the complete exhaust system every 10,000 miles (16,000 km). Check body areas near the exhaust system. Look for broken, damaged, missing, or out-of-position parts. Also inspect for open seams, holes, loose connections, or other conditions which could cause heat build-up at the rear body floor pan, or could let exhaust fumes seep into the passenger compartment. Dust or water in the cabin may indicate a leak in that area. Required repairs should be made at once.

14. DPF (Clean Filter) — Clean the filter every 100,000 miles (160,000 km) or 3,000 hours whichever occurs first.
15. DPF (Pressure Difference Sensor 0 Point Adjustment) — Adjust the sensor every 100,000 miles (160,000 km) or 3,000 hours whichever occurs first.
16. DPF (Pressure Difference Sensor Hose) — Inspect the sensor hose every 100,000 miles (160,000 km) or 3,000 hours whichever occurs first. Replace the sensor hose every 250,000 miles (400,000 km).
17. Fuel Line System — Inspect the fuel tank, cap and lines for damage which could cause leakage every 10,000 miles (16,000 km). Inspect fuel cap for correct sealing ability and indications of physical damage. Replace any damaged or malfunctioning parts.
18. Brake Lining and Pad for Wear — Check drum brake lining and disc brake pad for wear or cracks every 10,000 miles (16,000 km). Check brakes (including parking brake) more often if operating conditions or driving habits result in frequent braking.  
Front disc brakes have built-in wear noise indicators which are designed to make a high pitched squeal or cricket-like warning sound when the brake pads are worn to the point where new pads are needed.  
When the truck is in motion, the sound may be constant or it may come and go. Pressing the brake pedal firmly may cause the sound to stop.  
Have the brake linings or the brake pads replaced by your authorized dealer as soon as possible after the warning first becomes evident.  
Failure to do so can result in expensive damage to the brake system or a serious accident.
19. Brake Drum and Rotor for Wear and Damage — Check brake drums (rear and parking) and rotors (front) for wear or damage every 20,000 miles (32,000 km) or 12 months whichever occurs first.
20. Brake Electric Vacuum Pump (NPR-HD, NPR-XD models) — Inspect the brake electric vacuum pump operation every 10,000 miles (16,000 km) or 12 months, whichever occurs first.
21. Brake Fluid — Check the fluid in the brake fluid reservoir every 10,000 miles (16,000 km). Replace the fluid every 30,000 miles (48,000 km).
22. HBB Fluid (NQR, NRR models) — Replace ATF Dexron®-III fluid every 24 months or 30,000 miles (48,000 km), whichever occurs first.
23. Brake Line and Hoses — Check lines and hoses for proper hook-up, binding, leaks, cracks, chafing, etc. every 20,000 miles (32,000 km).  
Any questionable parts should be replaced or repaired at once.  
When rubbing or wear is noted on lines or hoses, the cause must be corrected at once.
24. Parking Brake Cable — Check the parking brake cable every 10,000 miles (16,000 km) or 12 months whichever occurs first.
25. Automatic Transmission Fluid — Check the automatic transmission fluid level at each engine oil change and replace fluid every 30,000 miles (48,000 km). Do not overfill.

26. External Automatic Transmission Filter (if equipped) — Replace external filter every 30,000 miles (48,000 km).
27. Differential Gear Oil — Replace lubricant every 30,000 miles (48,000 km). Check lubricant level every 10,000 miles (16,000 km) or every 12 months, and add lubricant to within 0 to 10 mm (0 to 0.4 inch) of the bottom edge of the filler hole if necessary.
28. Power Steering Fluid — Replace power steering fluid every 24 months or 30,000 miles (48,000 km), whichever occurs first.
29. Power Steering Oil Hoses — Replace power steering oil hoses every 24 months or 50,000 miles (80,000 km), whichever occurs first.
30. Steering wheel free play — Check steering wheel free play after the first 650 miles (1,040 km) and then every 6,500 miles (10,400 km).

Steering wheel free play

10 - 50 mm (0.39 - 1.97 in)

31. Steering Gear Box Torque — Retighten the attaching bolts of the steering gear box to the specified torque every 12 months or every 20,000 miles (32,000 km) whichever occurs first.

Steering gear box tightening torque

**103 N·m (10.5 kgf-m/76 lb·ft)**

32. Driveshaft Flange Torque — Check the fixing bolts of driveshaft flange for looseness or damage after the first 10,000 miles (16,000 km).

Driveshaft flange tightening torque

**103 N·m (10.5 kgf-m/76 lb·ft)**

33. Driveshaft Lubrication — Lubricate the grease fitting on the center bearing, as well as each universal joint and spline coupling every 12 months or 10,000 miles (16,000 km) whichever occurs first.
34. Leaf Spring U-bolt Torque — Tighten the U-Bolt nuts to the specified torque after the first 650 miles (1,040 km), thereafter every 10,000 miles (16,000 km).

Model	Leaf spring U-bolt nut tightening torque	
	Front	Rear
NPR-HD	<b>127 N·m (13.0 kgf-m/94 lb·ft)</b>	<b>177 N·m (18.0 kgf-m/131 lb·ft)</b>
NPR-XD, NQR, NRR	<b>196 N·m (20.0 kgf-m/145 lb·ft)</b>	<b>284 N·m (29.0 kgf-m/209 lb·ft)</b>

35. **Wheel Nut Torque** — Check tires for excessive or abnormal wear, or damage. Also check tire inflation pressures and adjust. Be sure wheels are not bent or cracked and that wheel nuts have been tightened to the specified torque after the first 650 miles (1,040 km) and then every 6,500 miles (10,400 km). Note that there are left and right hand threads.

Wheel nut tightening torque
<b>500 N·m (50 kgf·m/362 lb·ft)</b>

36. **King Pin** — Lubricate the grease fitting on the king pins every 12 months or 10,000 miles (16,000 km) whichever occurs first.
37. **Wheel Bearing Grease** — Clean and repack front wheel bearings every 24 months or 30,000 miles (48,000 km) whichever occurs first.
38. **Air Conditioner Blower Filter** — The air conditioner blower filter should be removed and cleaned once a month.
39. **Exhaust Injector** — Clean the exhaust injector every 110,000 miles (176,000 km).
40. **DEF Supply Pump Filter Element** — Replace the DEF supply pump filter element every 120,000 miles (192,000 km) or 24 months whichever occurs first.
41. **Starter** — The color displayed by the starter indicator light will change from green to amber when the number of times remaining is 0 or below and the screen is selected. When the indicator light (amber) comes on, have the vehicle inspected/serviced at the nearest Isuzu Dealer.

## Owner Safety and Routine Maintenance

Listed below are vehicle checks which should be made periodically by either the owner or a qualified technician to ensure proper performance and safety of your vehicle. Take any problems promptly to a technician for service advice.

For your safety and that of others, any of the safety-related components that may have been damaged in an accident should be checked and necessary repairs performed before operating your vehicle.

At the minimum, these routine checks should be made every 6 months or 10,000 miles (16,000 km), whichever comes first. Whenever repairs are necessary, have them completed before operating the vehicle.

### A: Parking Brake —

Park on a fairly steep hill and hold the vehicle with the parking brake only. This checks holding ability.

Before checking item (B) below, be sure to have enough room around the vehicle. Then firmly apply both the parking brake (see "Parking Brake" Section 5 for procedure) and the regular brakes. Do not use the accelerator pedal. If the engine starts, be ready to turn off the engine control switch at once. Take these precautions because the vehicle could move without warning and possibly cause injury or property damage.

### B: Starter Safety Switch —

Check by trying to start the engine in each gear. The starter should crank only at selector position "P" or "N".

### C: Transmission Shift Indicator —

Check that the indicator points to the gear chosen.

### D: Steering —

Be alert for any changes in steering action. An inspection or service is needed when: the steering wheel is harder to turn or has too much free play, or when there are strange sounds when turning or parking.

### E: Wheel Alignment, Balance, and Tires —

Check tires for abnormal wear or damage. Also, check for damaged wheels. A pull right or left on a straight and level road may show the need for a wheel alignment. A vibration of the steering wheel or seat at normal highway speeds may mean a wheel balancing is needed. Check tire pressure when the tires are "cold," at least monthly, and whenever the vehicle is serviced.

Check the pressure more often if daily checks show it's needed. (Refer to "Recommended Daily (Pre-operation) Inspections" on page 1-32.) Change tire pressure as needed when changing loads.

**F: Brakes —**

Be alert to illumination of the brake system warning light or brake low vacuum warning light (NPR-HD, NPR-XD models) or brake booster warning light (NQR, NRR models), or the tone alarm, or changes in braking action, such as repeated pulling to one side, unusual sounds when braking, increased brake pedal travel or harder pedal. The front and rear brakes are attached to an auto adjuster mechanism. If there are no defects, as the pedal travel is properly maintained, adjustments are not necessary. Check regularly that the brake fluid reservoir (left-hand side of the instrument panel) or HBB reservoir (NQR, NRR models: left side behind the cab) is properly filled and check for fluid leaks. Any of these conditions could indicate the need for brake system inspection and/or service.

**G: Exhaust System —**

Be alert for any changes in the sound of the exhaust system or any smell of fumes. These are signs the system may be leaking. Have it checked and/or repaired at once. (Refer to "Engine Exhaust Emissions Caution (Carbon Monoxide)" on page 3-4.)

**H: Windshield Wipers and Washers —**

Check operation and condition of the wiper blades. Check the flow of the washer spray.

**I: Defroster —**

Turn the outlet selector knob to "Defroster" and the fan speed control knob to the fully clockwise position. Then check the airflow from the ducts at the inside base of the windshield.

**J: Rearview Mirrors and Sun Visors —**

Check that friction joints hold mirrors and sun visors in place.

**K: Horn —**

Sound the horn, now and then, to be sure it works.

**L: Lap-Shoulder Belts —**

Check the seat belt system (including webbing, buckles, latch plates and anchors) for proper operation, and for damage.

**M: Seat Adjusters —**

When adjusting the driver's manual seat, be sure the seat adjusters latch by pushing the seat forward and backward. Do not attempt to adjust the seat when the vehicle is in motion.

**N: Lamps —**

Check panel lighting, warning lamps, indicator lamps and interior lamps. On the outside, check: license plate lamps, side marker lamps, reflectors on outside mirrors, headlamps, parking lamps, identification and clearance lamps, taillights, brake lamps, turn signals, cornering lamps, backup lamps and hazard warning flashers. Have headlamp aim checked immediately if beams seem improperly aimed.

**O: Glass, Mirrors, Lights and/or Reflectors Condition —**

Look for broken, scratched, dirty or damaged glass, mirrors, lamps or reflectors that could reduce the view or visibility, or cause injury. Replace, clean or repair promptly.

**P: Door Latches —**

Check that doors close, latch and lock tightly. Check for broken, damaged or missing parts that might prevent tight latching.

**Q :Tilt Cab (Driving Position) —**

Be sure the tilt lever is down and locked.

**R: Fluid Leaks —**

Check for fuel, water, oil or other fluid leaks by looking at the surface beneath the vehicle after it has been parked for a while. If you notice diesel fumes or fluid at any time, have the cause found and corrected at once.

**S: Underbody —**

Corrosive materials used for ice removal, snow removal and dust control can collect on the underbody. If these materials are not removed, accelerated corrosion (rust) can occur on underbody parts such as fuel lines, frame, floor pan and exhaust system. At least every spring, flush these materials from the underbody with plain water. Take care to clean well any areas where mud and other debris can collect. Sediment packed in closed areas of the frame should be loosened before being flushed.

### Checking Components that Showed Abnormalities during Previous Operation

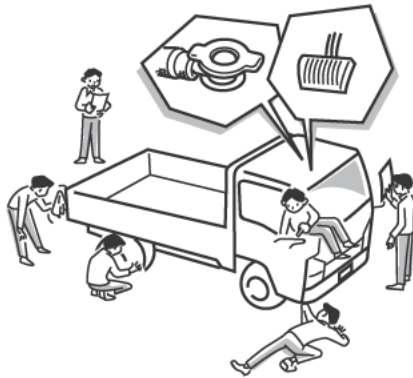

Check the components that showed abnormalities during the previous operation. Have any abnormalities repaired by your Isuzu Dealer before using the vehicle.

## Recommended Fluids, Lubricants and Diesel Fuels

It is extremely important to select correct lubricants and diesel fuels so that your Isuzu vehicle demonstrates its full performance over years.

Fill up the lubricants in accordance with the Maintenance Schedule specified for your vehicle. Use lubricants recommended in the list below.

The lubricant change intervals specified in the Maintenance Schedule and the terms and conditions of the new vehicle warranty assume the use of recommended lubricants listed below.

The following engine oil recommendations are based on operating your engine with the fuels recommended under "Diesel Fuel Requirement and Fuel System".

USAGE	FLUIDS/LUBRICANTS
Engine Oil	Quality recommended CJ4 (API designation). To determine the viscosity required *W-40 for your vehicle's diesel engine, see "Engine Oil and Gear Oil Viscosity Charts" on page 5-31.
Automatic Transmission Fluid	Genuine ISUZU SCS Transmission Fluid. (Do not use Dexron®-III)
Power Steering Fluid Hydraulic Brake Booster (HBB) Fluid (NQR, NRR models)	ATF Dexron®-III
Rear Axle	Multi purpose gear oil SAE80W-90 GL-5, SAE90 GL-5
Rear Axle (Limited slip differential (LSD))	Multi purpose gear oil SAE80W-90 GL-5, SAE90 GL-5 for limited slip differential together with limited slip differential lubricant additive (Part No. 8-88900-330-0) or equivalent.
Chassis Lubricant	Multi purpose grease with high temperature, good quality, lithium soap, extreme pressure grease.
Battery Terminals	Petroleum Jelly (outer surfaces)
Brake Fluid	Brake fluid DOT 3 or equivalent
Cab-Door Hinges and Latches Lubricant	A semi-fluid grease having extreme pressure properties and containing zinc oxide (Lubricant or equivalent)
Coolant	GENERAL MOTORS ENGINEERING STANDARDS GM6277M or equivalent. Mixture of water and good quality ethylene glycol base type anti-freeze conforming to Isuzu Factory Fill Long Life Coolant Part No 2-90531-809-0
Windshield Washer Solvent	Washer solvent
Driveshaft, Universal Joints and Sliding Sleeve Lubricant	NLGI #1 or #2 multi-purpose type grease
Driveshaft Center Bearing, Wheel Hub Bearing Lubricant	NLGI #2 or #3
Diesel Exhaust Fluid (DEF)	American Petroleum Institute (API) certified diesel exhaust fluid (DEF) International Organization for Standardization (ISO): AUS 32 ISO 22241

**ADVICE**

- Be sure to use the LSD gear oil additive mentioned above in vehicles equipped with limited slip differentials, and ensure there is an appropriate amount of the LSD gear oil additive, otherwise a chattering noise and/or excessive vibration may occur when turning.
- If abnormal noises occur despite having used the specified LSD gear oil additive, have it inspected and serviced at your Isuzu Dealer.

**Diesel Fuel Requirement and Fuel System** → Refer to page 1-35

**Engine Oil****Choosing the Right Quality Oil****ADVICE**

- If you do not use the oil intended for a vehicle equipped with a DPF, both the engine and the DPF may break down and fuel economy may decrease. Be sure, therefore, to use the oil intended for vehicles equipped with DPF.

**NOTE**

- Isuzu recommends engine oil that supports DPF (Low ash oil). Use of engine oil that does not support low ash will increase the PM produced by engine combustion. Consequently, the maintenance interval of the DPF filter will be reduced.



### Oil Identification Logo

A logo (symbol) is used on most oil containers to help you select the oil you should use. The top portion of the logo shows the oil quality by API designations such as CJ4 or others. The center portion of the logo shows the SAE viscosity grade, such as SAE \*W-40 (\* indicates viscosity on the low temperature side.). You should look for this logo on the oil container, and use ONLY oil containing the logo.

### Change Intervals

The oil and oil filter change intervals for your engine are based on the use of recommended oil quality and viscosity, as well as high-quality filters such as Isuzu genuine oil filters. Using oil other than recommended, or oil and filter change intervals longer than recommended, could reduce engine life. Damage to engines due to improper maintenance or use of incorrect oil quality and/or viscosity is not covered by the new vehicle warranty.

Your engine was filled with a high-quality engine oil when it was built. You do not have to change this oil before the first recommended change interval. Oil and filter change intervals depend on how you use your vehicle. For information on the proper oil and filter change intervals, refer to "Maintenance Schedule" in this section.

### Engine Oil Additives

Engine oils contain a variety of additives. Your engine should not need any extra additives if you use the recommended oil quality and change intervals.



### CAUTION

[Used Engine Oil]

- Used engine oil contains harmful contaminants that have caused skin cancer in laboratory animals. Avoid prolonged skin contact. Clean skin and nails thoroughly using soap and water—not mineral oil, fuels or solvents. Launder or discard clothing, shoes or rags containing used engine oil.

## Engine Oil and Gear Oil Viscosity Charts

Select appropriate engine and gear oils in accordance with the tables below. It is also important to select the viscosity appropriate for the temperature at which your vehicle operates. Use the following tables for making correct selections.

### Engine Oil

Engine oil viscosity (thickness) has an effect on fuel economy and cold-weather starting. Lower viscosity engine oils can provide better fuel economy; however, higher temperature weather conditions require higher viscosity engine oils for satisfactory lubrication.

When choosing an oil, consider the range of temperature your vehicle will be operated in before the next oil change. Then, select the recommended oil viscosity from the chart.

Do not use any viscosity of oil not recommended. Such oils could cause engine damage.

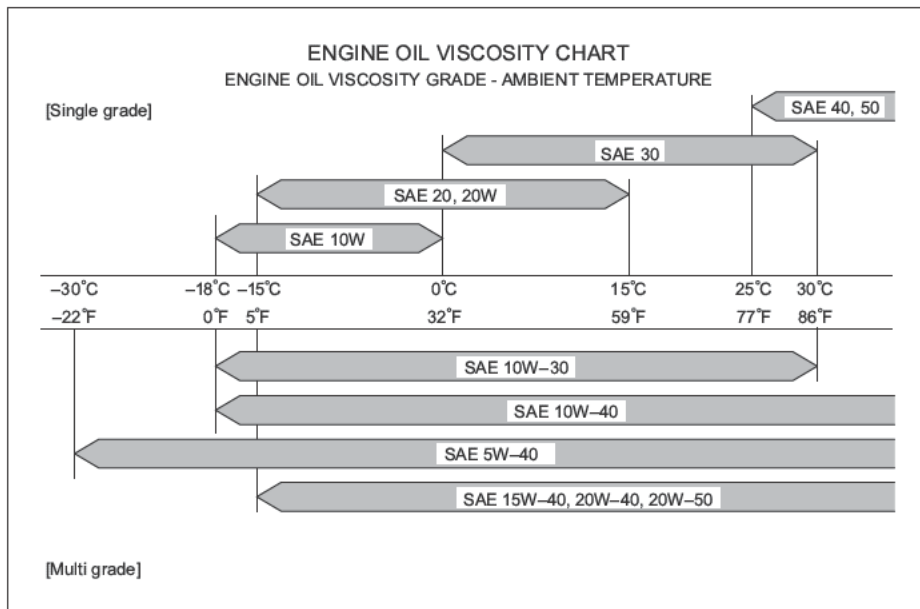

This Engine Oil Viscosity Grade Chart shows general information. For this vehicle, oil with \*W-40 viscosity is recommended.

**Gear Oil**

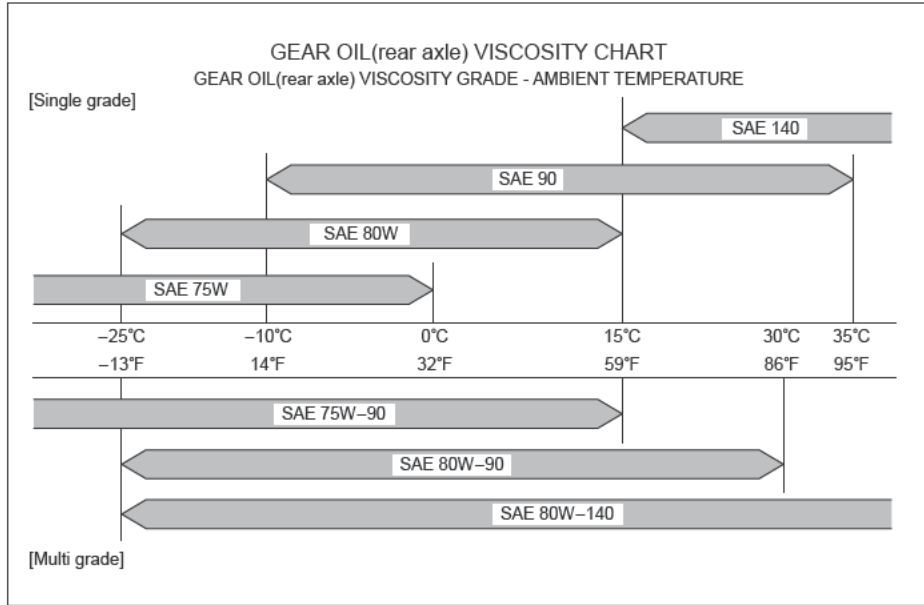

Lubrication Chart

- ⊙ : Change
- : Check and Replenish or Lubricate
- E : Engine oil
- G : Gear oil
- W : Wheel bearing grease
- C : Multipurpose type grease
- M : MoS<sub>2</sub> contained type grease
- B : Brake fluid
- A : Automatic transmission fluid

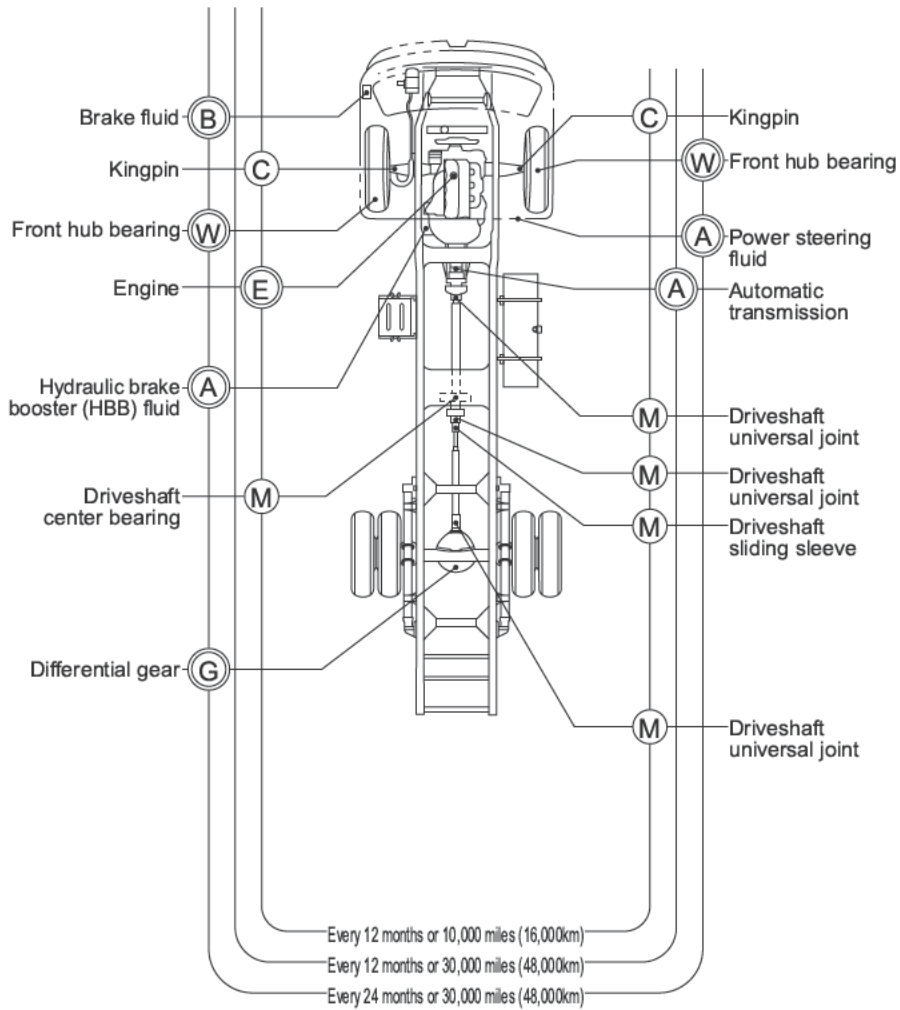

PE15-032

ISUZU

12-18-2015

ENCLOSURE 8 - 2

Service Manual



## Repair Instructions

### Front Hubs and Discs

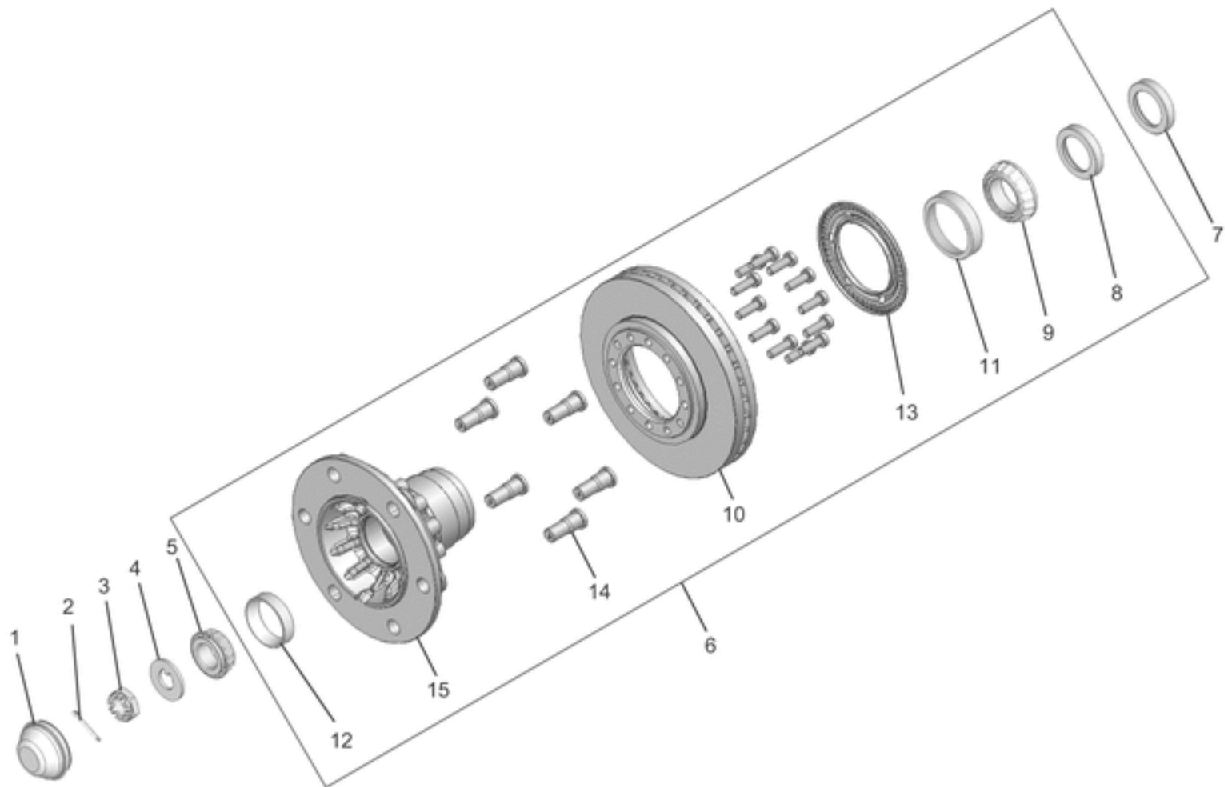

LNWG3CMF000101

#### Legend

- (1) Hub Cap
- (2) Cotter Pin
- (3) Nut
- (4) Washer
- (5) Outer Bearing
- (6) Hub and Disc Assembly
- (7) Spacer
- (8) Oil Seal
- (9) Inner Bearing
- (10) Disc
- (11) Inner Bearing Race
- (12) Outer Bearing Race
- (13) Speed Sensor Rotor
- (14) Stud
- (15) Hub

#### Removal Procedure

1. Tire and wheel assembly, refer to [Wheels and Tires](#) in this manual.
2. Disc Brake assembly, refer to [Hydraulic Foundation Brakes](#) in this manual.
3. Hub cap.

#### **Important:**

- **When removing the hub cap, be careful not to scratch or distort the cap sealing face.**

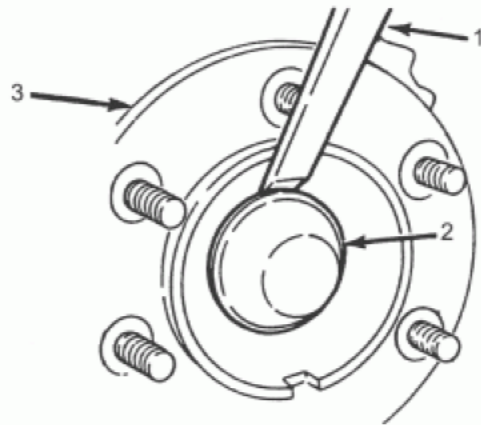

LNW33CSH002101

**Legend**

- (1) Pry Bar
- (2) Hub Cap
- (3) Hub and Disc Assembly

4. Cotter pin from nut and knuckle.

5. Nut and washer from knuckle.

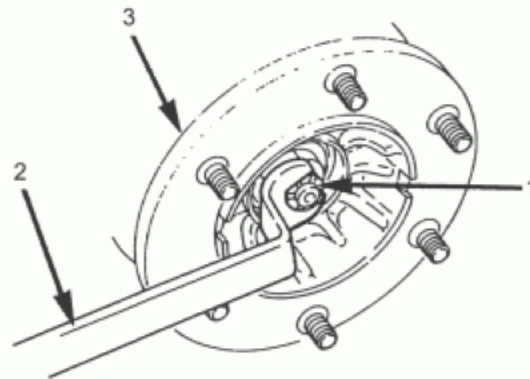

LNW33CSH002201

**Legend**

- (1) Nut
- (2) Wrench
- (3) Hub and Disc Assembly

6. Remove front hub and disc assembly.

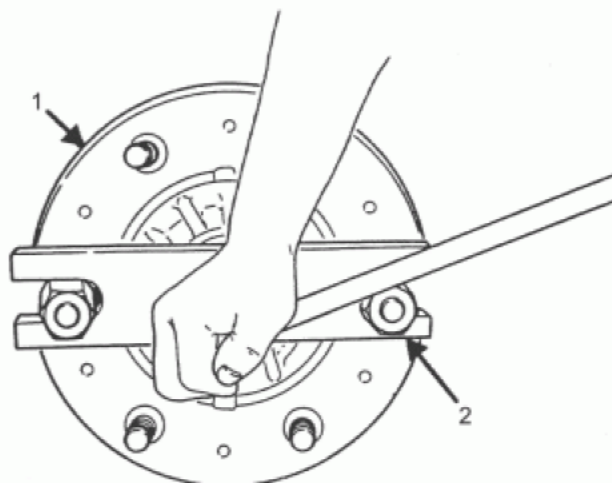

LNW33CSH002301

**Legend**

(1) Hub

(2) J 36429

**Important:**

- Do not drop the outer bearing as it comes off of the knuckle.

**Installation Procedure**

1. Remove excess grease from bearing and race area of hub.
2. Drive the inner and outer bearing races out of the hub. The bearing, oil seal and spacer will come out as the race is removed.
3. Drive the outer race out from the opposite side.

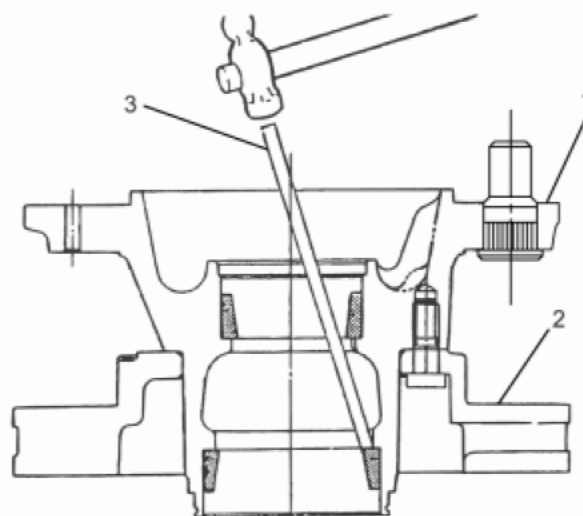

LNW43CSH000201

**Legend**

(1) Hub

- (2) Disc
- (3) Brass Bar

### Clean

- Spray the hub, bearings and races with non-flammable solvent and wipe dry.

### Inspection Procedure

1. Bearing races- check the fit of the bearing cups in the hub. If the bearing cups are loose or can be rotated in the bore, the hub must be replaced. If the bearing cups are cracked or pitted, they must be replaced.
2. Bearings- inspect the bearings for excessive wear, chipped edges and other damage. Refer to [Tapered Roller Bearing Diagnosis](#), previously covered in this section. Slowly roll the rollers around the cone to detect any flat or rough spots. Replace damaged parts.

### Assembly

1. Lightly grease the bearing races. Using tools J 8092, J 35712 and J 35713, seat them completely into the hub.

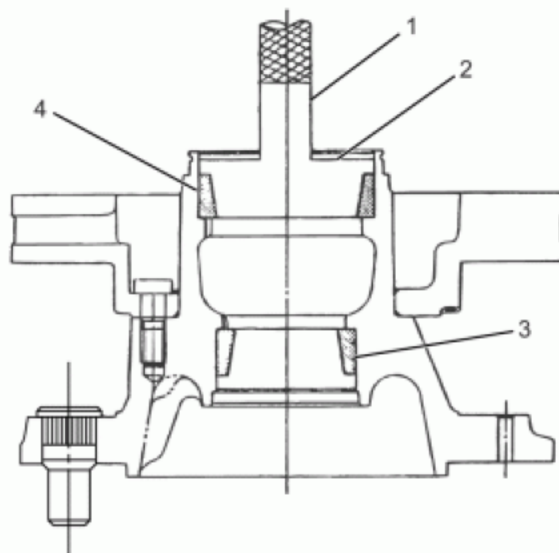

LNW43CSH000301

### Legend

- (1) Tool Grip J 8092
- (2) Tool J 35712 (Inner Bearing), J 35713 (Outer Bearing)
- (3) Outer Bearing Race
- (4) Inner Bearing Race

2. Apply an approved wheel bearing grease into the bearing rollers. The total amount of grease that should be in the hub cavity is 110 grams (3.9 oz) and in the hubcap (excluding the NRR model), 35 grams (1.2 oz), NRR model 65 grams (2.3 oz).

3. Install the inner bearing and the oil seal with the hollow side of the oil seal facing the bearing. See [Speed Sensor Replacement](#).

### Disc Replacement

1. Remove the speed sensor rotor. See [Speed Sensor Replacement](#).

***Do not reuse the sensor rotor because as it is removed, the sensor rotor may become warped or bent and ABS operation will be affected.***

2. Remove the disc. Use an inner hex wrench to loosen the disc fixing bolts.

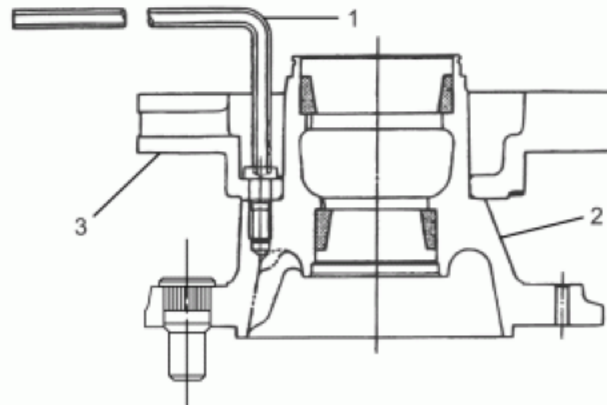

LNW43CSH000401

**Legend**

- (1) Inner Hex Wrench
- (2) Hub
- (3) Disc

3. Separate the hub and disc.
4. Inspect for disc excessive disc wear, warped condition and cracks.
5. Measure the disc thickness.

- Disc diameter: 293 mm (11.54 in)  
Standard 40.0 mm (1.57 in)  
Limit 37.0 mm (1.46 in)

- Disc diameter: 363 mm (14.30 in)  
Standard 42.0 mm (1.65 in)  
Limit 39.0 mm (1.54 in)

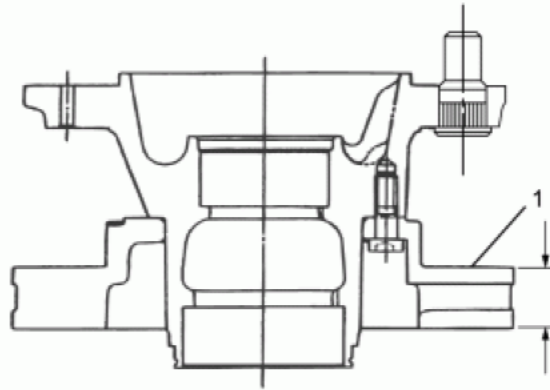

LNW43CSH000501

**Legend**

(1) Disc

6. Assemble hub and disc.

*For steps 5 and 6, refer to [Description and Operation](#) in this section.*

**Tighten**

- Bolts 103 N·m (76 lb ft).

7. Using a bench press, install speed sensor rotor.

**Front Wheel Stud Replacement****Important:**

*• If any wheel experiences damage to a single stud caused by a loose-running wheel, all the studs should be replaced. A loose-running wheel may cause only one stud to break, but the other studs could have internally fatigued to the point of being damaged. Replacing only the broken stud and remounting the wheel may cause further damage and personal injury. If the stud holes in the wheels become larger in size or distorted, replace the wheel.*

1. Remove wheel, hub, and disc as described earlier in this section.
2. Place hub on a suitable work surface and remove the studs, as required, using a hammer.
3. Inspect hub for warped condition, cracks, and enlarged stud holes.
4. Place the hub on a wood workbench or a block of wood approx. 6' by 6' to protect the wheel stud ends and threads.
5. Insert a new wheel stud using hammer.  
Be sure the wheel stud is stood squarely and seats completely.

**Notice:** Refer to [Description and Operation](#) in this section.

**Install or Connect**

6. Install the spacer, hub, and disc assembly onto the knuckle.

7. Install the outer bearing washer and nut onto the knuckle.

## Adjust

• Adjustment of hub bearing preload via wheel bolt tangential preload.

If adjusting the hub bearing preload while the wheel is not attached, refer to the following.

1. Turn the front hub to the left and right several times to stabilize the bearing.
2. Tighten the hub nut by turning the front hub by hand until the front hub does not turn.

**Notice:** Make sure to turn the hub when tightening as this will prevent the bearing from becoming damaged. Also, make sure to gently tighten the hub nut, and never use an air tool for tightening.

3. Loosen the hub nut and check that the hub rotates smoothly.

**Notice:** Make sure to fully loosen the bearing lock nut. If loosening is insufficient, a correct check will not be possible.

4. Put a string around the wheel bolts, hang a spring balancer on the string end, and gently pull it in a tangent direction. Then adjust while tightening the hub nut until the preload reaches the specified value.

**Notice:**

- If the preload is unstable, rotate the hub several times, stop the rotation completely and carry out measurement again.
- If it still does not become stable, re-perform the procedure from procedure "a".
- Check the hub for looseness, resistance, or abnormal heaviness.

Preload:

New Hub bearing = 10 - 34 N·m (2.2 - 7.7 lb·ft)

Re-used Hub bearing = 5 - 20 N·m (1.1 - 4.4 lb·ft)

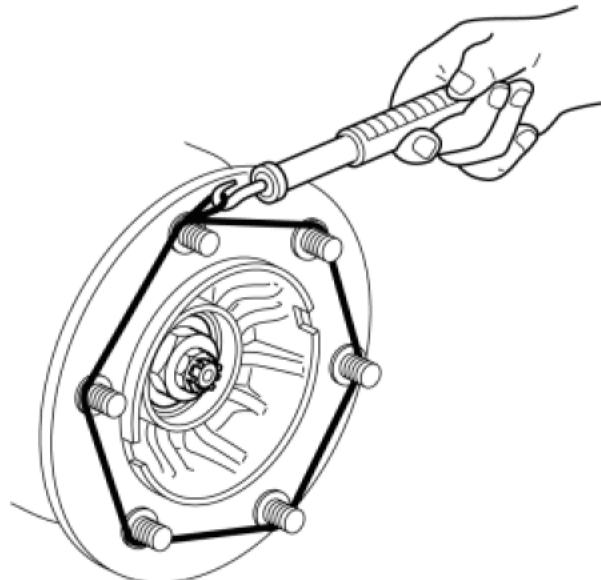

LNW93CSH003001

5. Sufficiently bend the cotter pin when installing. If the hub nut groove and the cotter pin hole do not align, align the hole by turning the hub nut in the minimum tightening direction.

**Notice:** Use a new cotter pin.

6. Apply grease into the hub cap and install it.
7. Return the caliper assembly to its original position.

#### Tighten

- Lock Pin Bolt 137 N·m (101 lb ft).

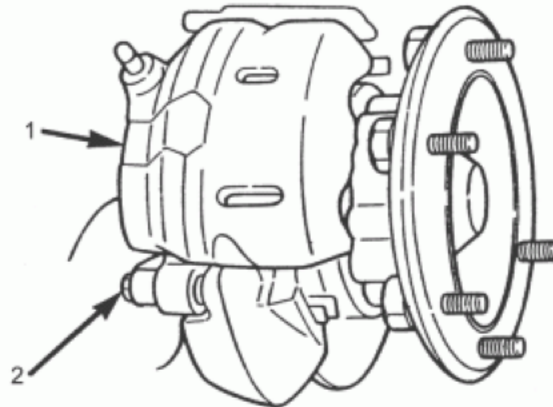

LNW33CSH003101

#### Legend

- (1) Caliper Assembly  
(2) Lock Pin Bolt

- Adjustment of hub bearing preload via hub nut tightening torque.

If adjusting the hub bearing preload while the wheel is attached, refer to the following.

8. After assembling the front hub and the outer bearing, assemble the hub nut and turn the hub to the left and right several times to stabilize the bearing.

9. Tighten the hub nut to the specified torque.

**Tightening torque:** 110 N·m (81 lb·ft)

**Important:** The tightening torque for both new bearings and reused bearings is the same.

**Notice:** Gently tighten the bearing lock nut, and never use an air tool for tightening.

10. Rotate the hub 3 times in the forward direction.

11. Loosen the hub nut. (Target: Approximately 90°)

**Notice:**

- Do not loosen the nut to the point where the hub becomes loose.
- Start the procedure again from the beginning if the nut is excessively loosened.

12. Tighten the hub nut to the specified torque.

**Tightening torque:** 15 N·m (11 lb·ft)

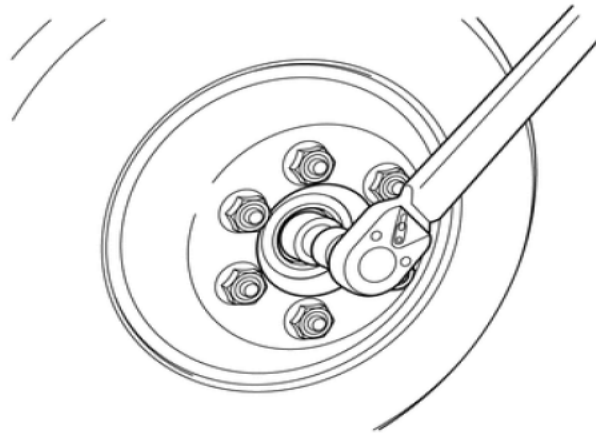

LNWE3CSH004001

**Notice:** Start the procedure again from the beginning if the hub nut does not rotate.

**Important:** The tightening torque for both new bearings and reused bearings is the same.

13. Turn the hub 3 times in the forward direction.

**Notice:**

- Rotate the hub several times in the forward direction and verify that there is no looseness, resistance, or abnormal heaviness.
- Start the procedure again from the beginning if there is any looseness, resistance, or abnormal heaviness.

14. Install the cotter pin and bend it firmly.

**Notice:**

- If the hub nut groove and the cotter pin hole do not align, align the hole by turning the hub nut in the minimum tightening direction.
- Start the procedure again from the beginning if tightening is performed with the hole positions inaccurately aligned.
- Use a new cotter pin.

15. Apply grease into the hub cap and install it.

16. Return the caliper assembly to its original position.

**Tighten**

- Lock Pin Bolt 137 N·m (101 lb ft).

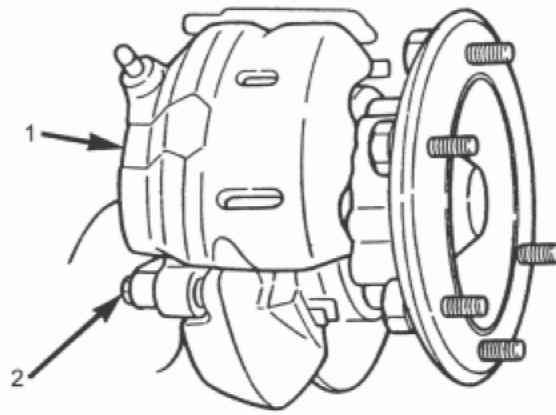

LNW33CSH003101

- Legend**  
(1) Caliper Assembly  
(2) Lock Pin Bolt