

RQ14-004
FOREST RIVER'S
5-22-2015
ENCLOSURE 8
AXLE ASSEMBLY - AL KO
AXLE

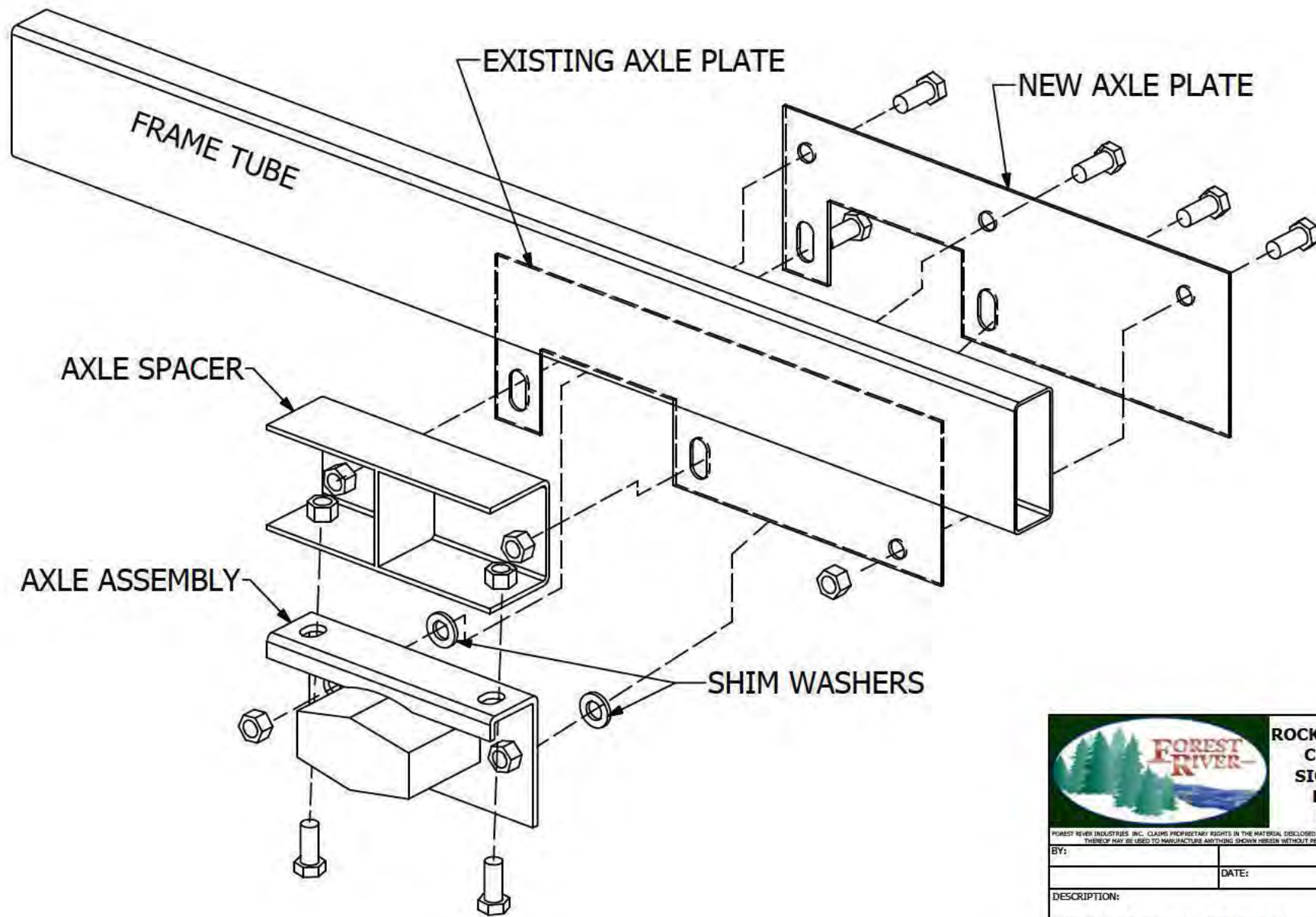

**ROCKWOOD/FLAGSTAFF
CLASSIC SUPER/
SIGNATURE ULTRA
LITE DIVISION
PLANT #10-C**

FOREST RIVER INDUSTRIES, INC. CLAIMS PROPRIETARY RIGHTS IN THE MATERIAL DISCLOSED HEREIN. NEITHER THIS DRAWING NOR ANY REPRODUCTION THEREOF MAY BE USED TO MANUFACTURE ANYTHING SHOWN HEREIN WITHOUT PERMISSION IN WRITING FROM FOREST RIVER INDUSTRIES, INC.

BY:	DATE:	ANGULAR TOLERANCE: ±1°
		FRACTIONAL TOLERANCE: ±1/16

DESCRIPTION:

ALKO AXLE ASSEMBLY

GAUGE:	FR PART NO.:	DWG NO.:	REV. X
SIZE C	APPROVED BY:	VENDOR:	SHEET 1 OF 1

RQ14-004
FOREST RIVER'S
5-22-2015
ENCLOSURE 8
AXLE ASSEMBLY -
DEXTER AXLE

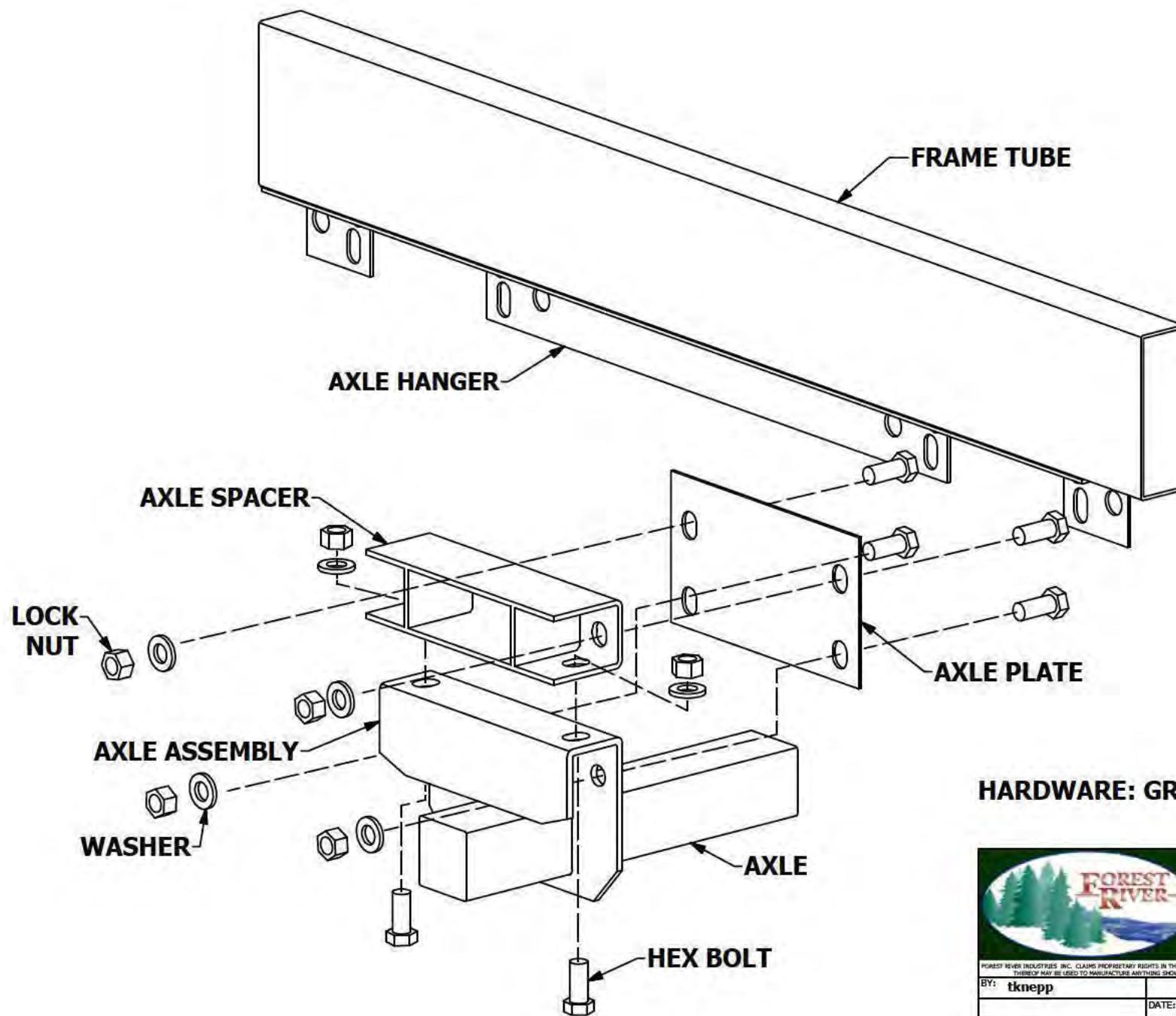

HARDWARE: GRADE 5



**ROCKWOOD/FLAGSTAFF
CLASSIC SUPER/
SIGNATURE ULTRA
LITE DIVISION
PLANT #10-C**

FOREST RIVER INDUSTRIES, INC. CLAIMS PROPRIETARY RIGHTS IN THE MATERIAL DISCLOSED HEREIN. NEITHER THIS DRAWING NOR ANY REPRODUCTION THEREOF MAY BE USED TO MANUFACTURE ANYTHING SHOWN HEREIN WITHOUT PERMISSION IN WRITING FROM FOREST RIVER INDUSTRIES, INC.

BY: tknepp	DATE: 10/16/2013	ANGULAR TOLERANCE: ±1°
		FRACTIONAL TOLERANCE: ±1/16

DESCRIPTION:

AXLE ASSEMBLY

C:\Vault Working Folder\Designs\Millersburg\PROJECTS\KARL AXLE ASSEMBLY

GAUGE:	FR PART NO.	DWG NO.	REV. X
SIZE C	APPROVED BY:	VENDOR:	SHEET 1 OF 1

RQ14-004

FOREST RIVER'S

5-22-2015

ENCLOSURE 8

LETTER TO CANADIAN

DEALERS no merge



Forest River, Inc.

55470 County Road 1, P.O. Box 3030, Elkhart, Indiana 46515-3030 • 574-389-4600 • Fax 574-296-7558

RE: TRANSPORT CANADA Safety Recall# 2014-003

Dear Forest River Dealer:

This notice is sent to you in accordance with the requirements of the Canadian Motor Vehicle Safety Act. Forest River Inc has decided that a defect that relates to motor vehicle safety exists in 2012 and 2013 Flagstaff, Rockwood, V-Lite and Windjammer Travel Trailers manufactured between February 3, 2012 and February 4, 2013.

On affected units under full GVWR and upon hitting a road bump or pot hole, the tire may strike the bottom of the floor, thereby potentially resulting in a tire blowout which may cause loss of control, property damage, personal injury and death.

This month, we have mailed out letters to customers who have been affected by Recall# **2014-003**. We are sending this information to you as a courtesy so that you will be informed about it when customers need the repair made. Attached you will find letters for each VIN affected that has been sold to you so that you will have a copy for their file. If it's still a stock unit, you will need to perform the repairs prior to selling the unit.

The solution for the problem is the addition of a riser kit. This is a simple repair, and ***when ordered, there will be instructions and a diagram included with the parts.*** If it's an Alko-Kober axle, you will need to order part# 10-FT-22; if it's a Dexter axle, you will need to order part# 10-19080A. The parts representatives are also aware of this information to ensure that you get the correct kit for the customer's unit.

When you file the claim for this repair, you will need to use repair code, 10-001820 and indicate that this is for the Recall# **2014-003**. The time allowed will be 1 hour per axle.

If you need any further assistance, please contact the following warranty reps:

Roger Beiler	rbeiler@forestriverinc.com	574-642-8931
Chris Hollowell	chollowell@forestriverinc.com	574-642-8943
Fred Yoder	fyoder@forestriverin.com	574-642-5166

Thank you for your assistance on this matter.

Sincerely,
Rockwood/Flagstaff Warranty Department

RQ14-004

FOREST RIVER'S

5-22-2015

ENCLOSURE 8

Letter to Dealers



Forest River, Inc.

55470 County Road 1, P.O. Box 3030, Elkhart, Indiana 46515-3030 • 574-389-4600 • Fax 574-296-7558

January 13, 2014

Address

Re: Inadequate clearance for affected units under **NHTSA Recall Campaign #: 13V554**

Selling/Serviceing Dealer,

This month, we have mailed out letters to customers who have been affected by Recall# 13V554. We are sending this information to you as a courtesy so that you will be informed about it when customers need the repair made.

The solution for the problem is the addition of a riser kit. This is a simple repair, and when ordered, there will be instructions and a diagram included with the parts. If it's an Alko axle, you will need to order part# 10-FT-22; if it's a Dexter axle, you will need to order part# 10-19080A. The parts representatives are also aware of this information to ensure that you get the correct kit for the customer's unit.

When you file the claim for this repair, you will need to use repair code, 10-001820 and indicate that this is for the Recall# 13V554. The time allowed will be 1 hour per axle.

If you need any further assistance, please contact the following warranty reps:

Roger Beiler	rbeiler@forestriverinc.com	574-642-8931
Chris Hollowell	chollowell@forestriverinc.com	574-642-8943
Fred Yoder	fyoder@forestriverin.com	574-642-5166

Thank you for your assistance on this matter.

Sincerely,

Rockwood/Flagstaff Warranty Department

RQ14-004
FOREST RIVER'S
5-22-2015
ENCLOSURE 8
US Owner Letter

April 11, 2017

IMPORTANT SAFETY RECALL CAMPAIGN ANNOUNCEMENT

NHTSA Recall Campaign #: 13V554

Unit Vehicle Identification Number:

Dear Forest River Trailer Owner,

This notice is sent to you in accordance with the requirements of the National Traffic and Motor Vehicle Safety Act.

Forest River Inc has decided that a defect that relates to motor vehicle safety exists in the Rockwood or Flagstaff travel trailers with the VIN number indicated above.

SAFETY DEFECT

There is not adequate clearance between the tire and the bottom of the floor at full GVWR. The tire may hit the bottom of the floor in the event that the travel trailer should hit a bump or pot hole in the road. This contact may cause the tire to blow out unexpectedly, thereby potentially resulting in loss of control, property damage, personal injury or death.

REPAIRS

PLEASE TAKE YOUR UNIT PROMPTLY TO YOUR FOREST RIVER DEALER. At no charge to you, the dealer will perform the necessary repairs. The required repair procedure will require the removal of the axles so that a lift kit may be installed between the frame and the axles and the re-installation of the axles to the lift kit. Please contact your dealer and set up an appointment, this procedure may take more than a few hours.

REFUNDS

If you have paid to have this service performed prior to receiving this notice you can receive a full refund. Please mail your paid original invoice or receipt to attention Rockwood or Flagstaff Warranty Forest River, Inc. P.O. Box 3030 Elkhart, Indiana 46515-3030.

CHANGED ADDRESS OR SOLD THE VEHICLE?

Any vehicle lessor receiving this recall notice must forward a copy of the notice to the lessee within 10 days.

If your dealer does not make the required repair promptly and without charge, you may contact Forest River Customer Service at 574-642-2640. You also may contact the National Highway Traffic Safety Administration, 1200 New Jersey Ave. SE, Washington, DC 20590; or call the toll free Vehicle Safety Hotline at 1-888-327-4236 (TTY: 1-800-424-9153); or go to <http://www.safecar.gov>.

We regret the inconvenience this situation may have caused you. However, Forest River, Inc. believes in the early detection and immediate correction of potential concerns.

Thank you for your understanding.

Sincerely,

Forest River Inc.
Warranty and Service