

PE14-027

FORD

11/7/2014

APPENDIX F

ILUSTRATIONS

AND

Engineering Review PAGE 5

PE14-027

FORD

11/7/2014

APPENDIX F

Illustrations

## Brake Flexible Hose

## Material

Item	Specification
Motorcraft® DOT 4 LV High Performance Motor Vehicle Brake Fluid PM-20	WSS-M6C65-A2 and ISO 4925 Class 6

## Removal

**⚠ WARNING:** Before beginning any service procedure in this section, refer to Safety Warnings in [Section 100-00](#). Failure to follow this instruction may result in serious personal injury.

**NOTICE:** Do not spill brake fluid on painted or plastic surfaces or damage to the surface may occur. If brake fluid is spilled onto a painted or plastic surface, immediately wash the surface with water.

**NOTICE:** Do not allow grease, oil, brake fluid or other contaminants to contact the pad lining material, or damage to components may occur. Do not install contaminated pads.

**NOTE:** Removal steps in this procedure may contain installation details.

## NOTE:

1. With the vehicle in NEUTRAL, position it on a hoist. For additional information, REFER to [Section 100-02](#).
2. **NOTICE:** Make sure to protect the brake pads from contamination from the brake fluid during the brake flexible hose installation and the brake caliper bleeding.
  - To install, tighten the brake tube fitting to 17 Nm (150 lb-in).
  - To install, tighten the brake flexible hose bracket bolt to 30 Nm (22 lb-ft).

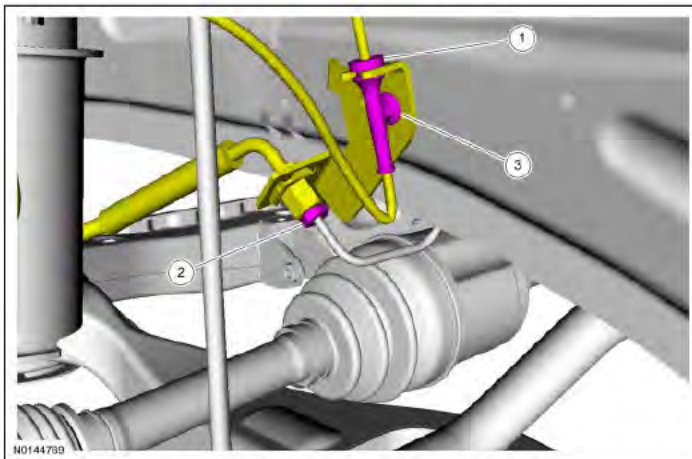

3. Discard the specified component. Follow local disposal regulations.
  - To install, tighten to 47 Nm (35 lb-ft).

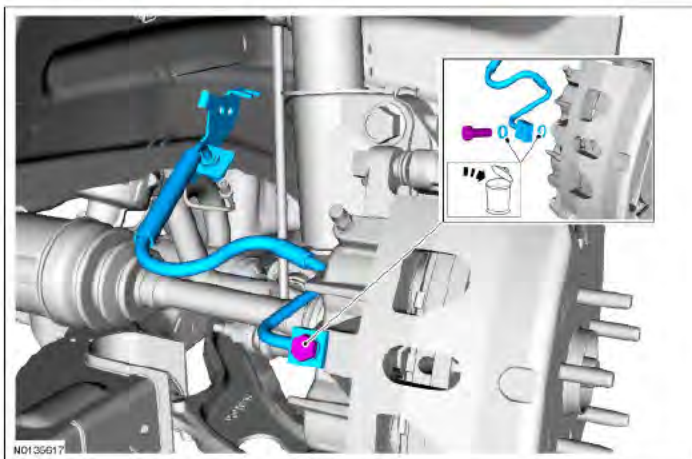

## Installation

1. To install, reverse the removal procedure.
  - Lubricate the brake caliper flow bolt threads and new washers with clean brake fluid before installing the brake caliper flow bolt into the brake caliper.
  - Bleed the brake caliper. For additional information, REFER to [Section 206-00](#) for Component Bleeding.

---

Copyright © 2014 Ford Motor Company

Figure 1: 2016 U502 Front Brake Routing Change

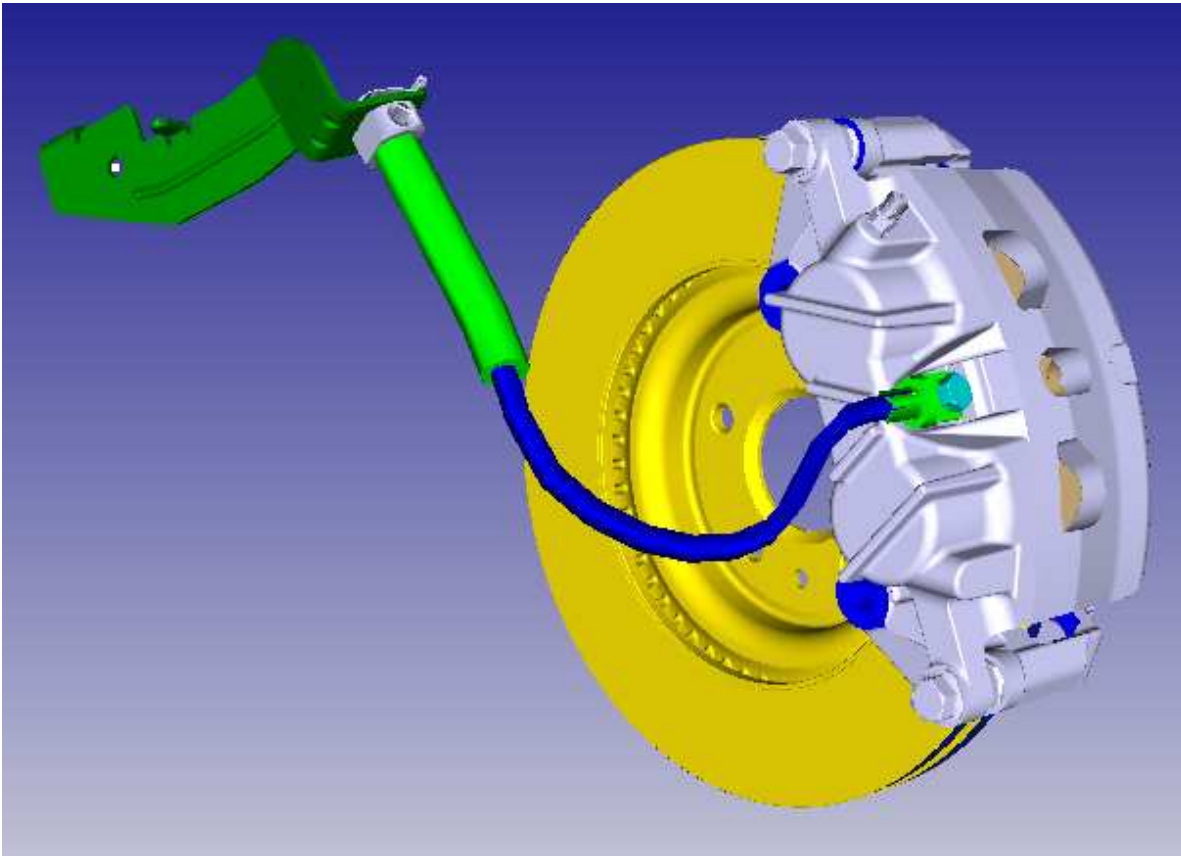
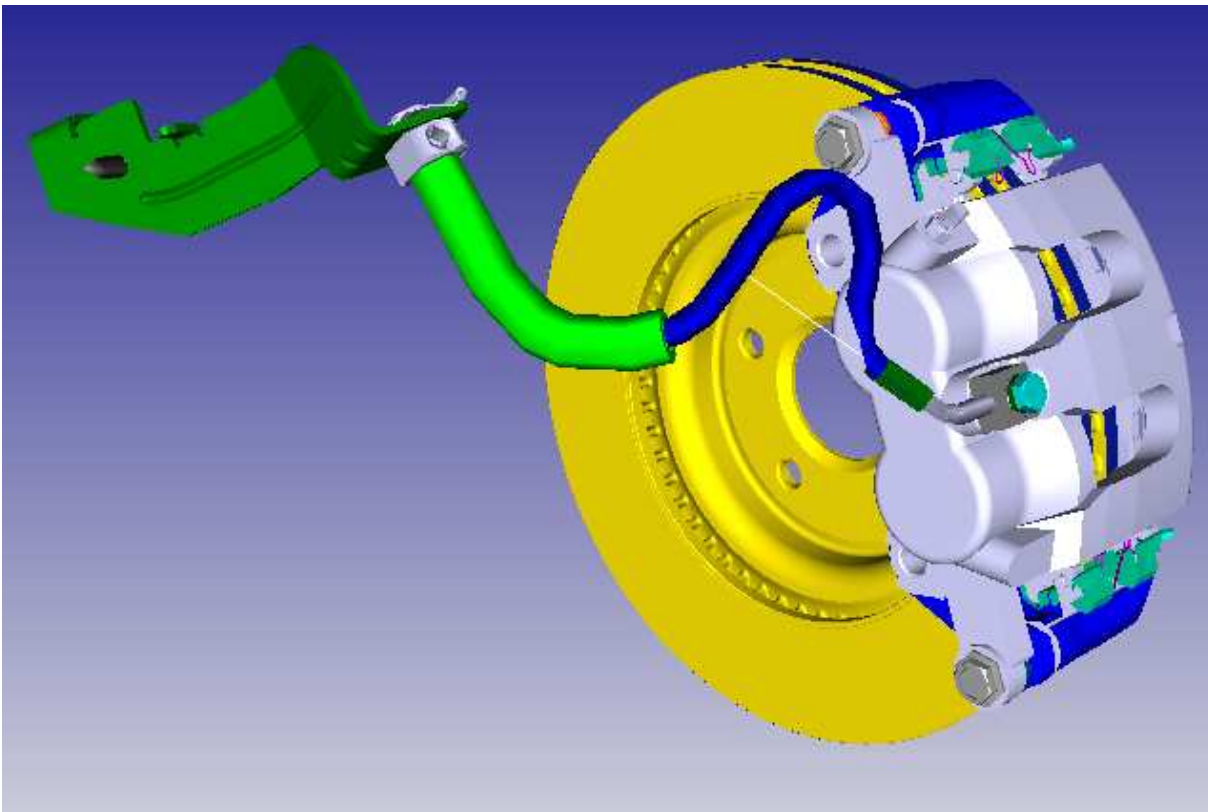

Figure 2: 2013 U502 Front Brake



PE14-027

FORD

11/7/2014

APPENDIX F

Engineering Review

---

**From:** [REDACTED]  
**Sent:** Tuesday, August 05, 2014 10:44 AM  
**To:** [REDACTED]  
**Subject:** 2011-2014 Explorer Brake Jounce Hose

Attached to this file is an update/revised version of the 2011-2014 Explorer Brake Jounce Hose excel file I was using this morning. Please discard previously received versions.



---

**From:** [REDACTED]  
**Sent:** Monday, August 04, 2014 1:26 PM  
**To:** [REDACTED]  
**Subject:** Emailing: 2011 thru 2014 Explorer Alleged Leak at Jounce Hose Comm Symp search from CDR on 07232014.xlsx  
**Attachments:** 2011 thru 2014 Explorer Alleged Leak at Jounce Hose Comm Symp search from CDR on 07232014.xlsx

Attached is an excel file with the 2010-2014 Explorer Alleged Jounce Hose Leak data. Please call me if you have any questions regarding this data file. A copy has been sent to Mark Tuneff for his reference as well.

[REDACTED]  
Product Concern Analyst  
Automotive Safety Office  
[REDACTED]



# 2011-2014 Explorer Alleged Brake Line "Jounce" Hose Leaks

Fleet Service Hotline received approximately 10-12 reports from a Police fleet in the Baltimore/Washington DC area which indicated they had several 2013 Explorer vehicles in their fleet that had developed leaks in the jounce hoses.

CDR search of 2011-2014 Explorer; Chassis service brakes with symptoms; "bulging/swollen line or hose; damage-chafed/excessive wear; damage-cracked/fractured/split; damage-cut/torn/frayed; leak-fluid;"

Read the reports with key words that included; leak, brake, fluid, hose, line, etc.

I attempted to identify the alleged leaking component. e.g. caliper, master cylinder, jounce hose, etc.

Sort Field 3 attempts to identify the location of the alleged leaking component, e.g. lf, rf, lr, rr, as applicable and discernable based on the customer and technician comments and not necessarily based on alleged causal base part number.

No VOQ reports of alleged leaking brake jounce hoses on 2010-2011 explorer were located.

Reports where Customer or Technician **comments** indicate a leak in the brake system (not vacuum)

Count of ECI Record ID		Model Year				Grand Total
Sort Field One	Source Code	2011	2012	2013	2014	
1	AWS	185	134	224	71	614
	FMC360	1	3		2	6
	GCQIS Ford	14	5	25	2	46
	MORS\CUDL	1				1
<b>1 Total</b>		<b>201</b>	<b>142</b>	<b>249</b>	<b>75</b>	<b>667</b>
<b>Grand Total</b>		<b>201</b>	<b>142</b>	<b>249</b>	<b>75</b>	<b>667</b>

Component/source of the alleged brake fluid leak (not vacuum)

Count of ECI Record ID		Model Year				Grand Total	
Sort Field One	Description of leak	2011	2012	2013	2014		
1	at caliper	63	84	93	25	265	
	into booster	46	17	57	10	130	
	(blank)	13	18	31	3	65	
	at hcu	31	13	10	7	61	
	at mc	36	4	12	1	53	
	at jounce hose	6	2	22	13	43	
	at jounce hose fitting	2	1	8	11	22	
	not stated	1	2	2	2	7	
	at cap		1	3	1	5	
	bulge in hose			4		4	
	at banjo bolt			2	1	3	
	hard line in engine compartment				2	1	3
	hose split				1		1
	rub on toc line	1					1
	jounce hose stretch				1		1
	at brake pipe	1					1
	Brake line	1					1
no part number provided							
pin hole leak				1		1	
<b>1 Total</b>		<b>201</b>	<b>142</b>	<b>249</b>	<b>75</b>	<b>667</b>	
<b>Grand Total</b>		<b>201</b>	<b>142</b>	<b>249</b>	<b>75</b>	<b>667</b>	

74 reports on 64 unique VINs

**Alleged Brake line/hose leak (not vacuum)**

Count of ECI Record ID		Model Year				Grand Total
Sort Field One	Description of leak or	2011	2012	2013	2014	
1	hose split			1		1
	jounce hose stretch			1		1
	at banjo bolt			2	1	3
	bulge in hose			4		4
	at jounce hose fitting	2	1	8	11	22
	at jounce hose	6	2	22	13	43
<b>1 Total</b>		<b>8</b>	<b>3</b>	<b>38</b>	<b>25</b>	<b>74</b>
<b>Grand Total</b>		<b>8</b>	<b>3</b>	<b>38</b>	<b>25</b>	<b>74</b>

**By hose location**

Sort Field One	1
Dupe Vin 2	OK

Count of ECI Record ID	Description of leak or	Location of hose					Grand Total	
		at banjo bolt	at jounce hose	at jounce hose fitting	bulge in hose	hose split		jounce hose stretch
?			2					2
both								1
lf			7	2			1	10
lr			5	3				8
not stated		1	2					3
rf		1	14	10	3			28
rr			5	5				10
(blank)				2				2
<b>Grand Total</b>		<b>2</b>	<b>35</b>	<b>22</b>	<b>3</b>	<b>1</b>	<b>1</b>	<b>64</b>

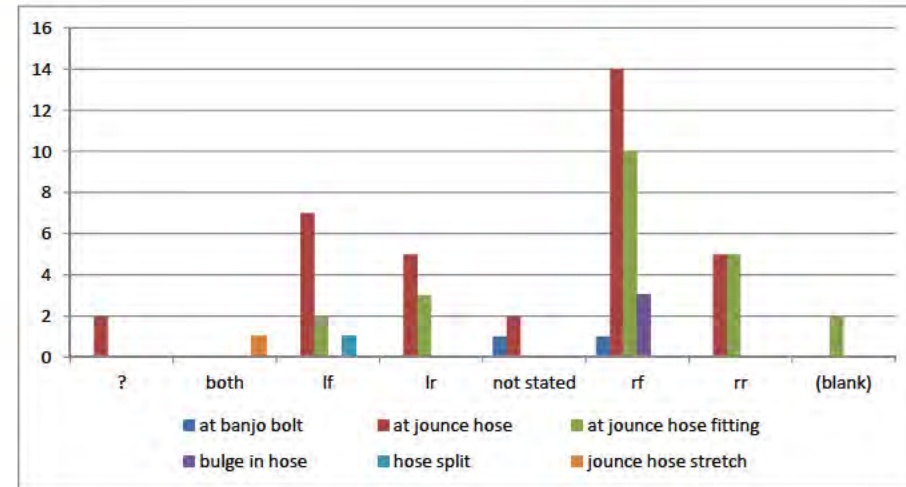

**By Production Date**

Description of leak or source (Multiple Items)

Count of ECI Record ID		Production Date	Total
Dupe Vin 2	Years		
OK	2011	Jan	1
		Feb	2
		Mar	2
		Apr	2
		May	1
		Jun	1
		Jul	1
		Aug	1

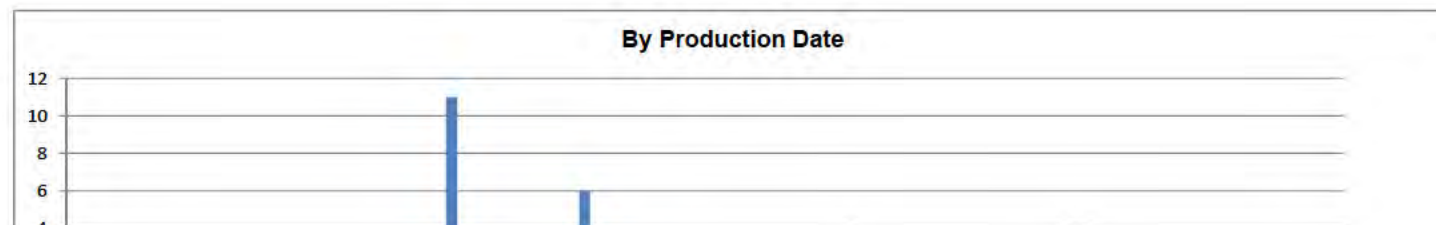

OK	2011	Sep	2
		Oct	
Nov			
Dec			
2012	Jan		
	Feb		
	Mar	11	
	Apr	1	
	May		
	Jun	1	
	Jul	1	
	Aug	6	
	Sep	2	
	Oct	2	
	Nov		
	Dec		
2013	Jan	1	
	Feb	1	
	Mar	2	
	Apr		
	May	2	
	Jun	4	
	Jul	3	
	Aug	2	
	Sep	1	
	Oct	1	
	Nov	2	
	Dec	1	
2014	Jan	2	
	Feb	4	
	Mar	4	
	Apr		
	May		
	Jun		
	Jul		
	Aug		
	Sep		
	Oct		
	Nov		
	Dec		
<b>OK Total</b>			<b>64</b>
<b>Grand Total</b>			<b>64</b>

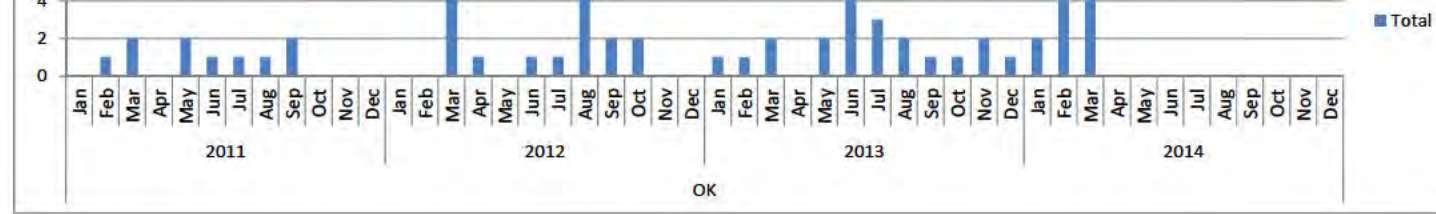

By Mileage at Time of Repair/Report	
Sort Field One	1
Description of leak or source	(Multiple Items)

Count of ECI Record ID Dupe Vin 2	Mileage	Model Year				Grand Total
		2011	2012	2013	2014	
OK	0-9999	2		12	22	36
	10000-19999	2		5	2	9
	20000-29999	2	1	4		7
	30000-39999	1	1	6		8
	40000-49999			3		3
	50000-59999		1			1
<b>OK Total</b>		<b>7</b>	<b>3</b>	<b>30</b>	<b>24</b>	<b>64</b>
<b>Grand Total</b>		<b>7</b>	<b>3</b>	<b>30</b>	<b>24</b>	<b>64</b>

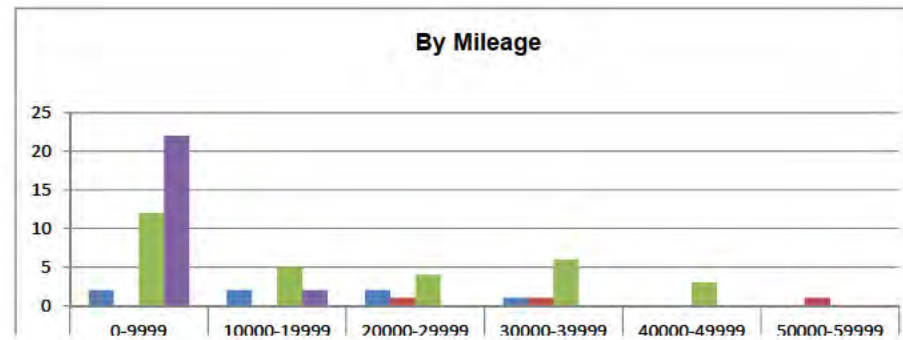

**Time In Service**  
 Sort Field One 1  
 Description of leak or source (Multiple Items)

Count of ECI Record ID Dupe Vin 2	Time In Service	Model Year				Grand Total
		2011	2012	2013	2014	
OK	0	1		1	4	6
	1			2	5	7
	2				3	3
	3			5	3	8
	4				3	3
	5				1	1
	6			2		2
	7	1			1	2
	8	1			1	2
	9			2	1	3
	10				1	1
	11	1		1		2
	12					
	13			2		2
	14			1		1
	15			1		1
	16					
	17					
	18					
	19		1			1
	20					
	21			2		2
	22					
	23		1	1		2
	24					
	25					
	26	1		1		2
	27			1		1
	28					
	29					
	30		1			1
	31					
	32					
	33					
	34					
	35					
	36	1				1
	37	1				1
	(blank)			8	1	9
<b>OK Total</b>		<b>7</b>	<b>3</b>	<b>30</b>	<b>24</b>	<b>64</b>
<b>Grand Total</b>		<b>7</b>	<b>3</b>	<b>30</b>	<b>24</b>	<b>64</b>

**By State/Province**

This information can be misleading as several of the GCQIS reports indicate the dealer name/address as Ford Fleet Services in Dearborn, MI (as Dealer Name; FORD MOTOR CO. FPSDGO FLT SVC)

Sort Field One 1  
 Description of leak or source (Multiple Items)

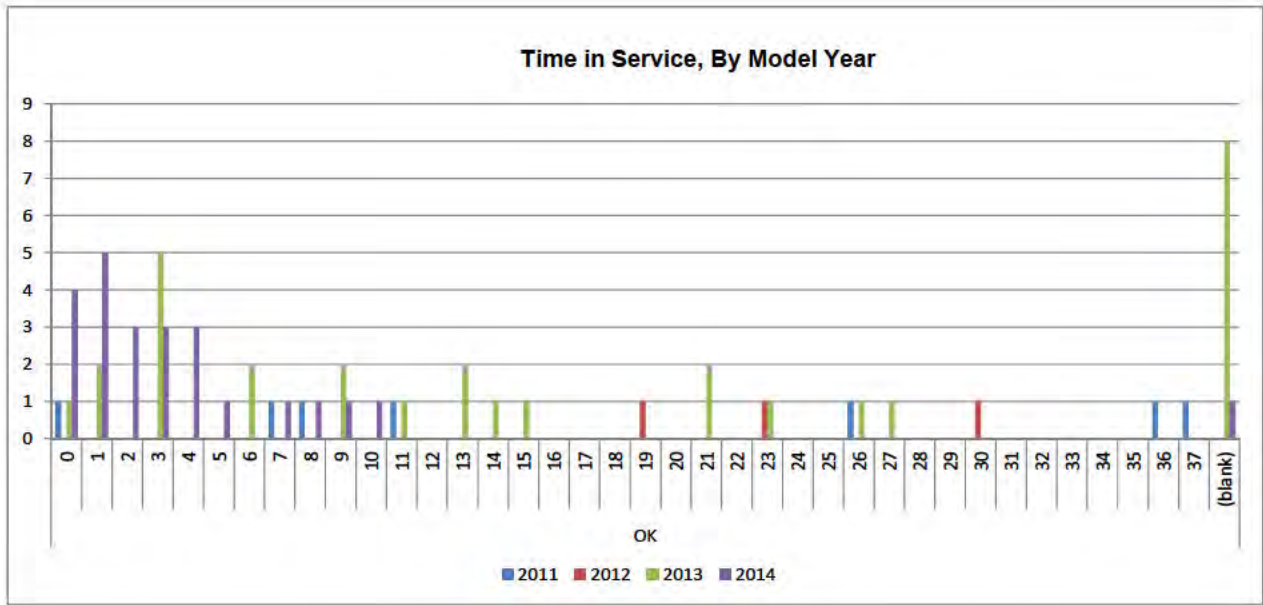
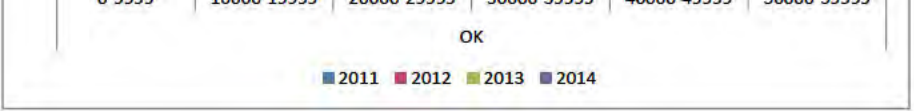

Count of ECI Record ID		Model Year				
Dupe Vin 2	Dealer State/Provi	2011	2012	2013	2014	Grand Total
OK	MI			7	1	8
	CA		1		6	7
	NJ			2	3	5
	MD	1		4		5
	NY			3	1	4
	MN			3	1	4
	GA			1	2	3
	AZ			1	2	3
	PA	1		1	1	3
	NC			1	1	2
	QC			1	1	2
	IL	1		1		2
	AL	1				2
	ID				1	1
	CO		1			1
	TN			1		1
	WV				1	1
	ON	1				1
	MA			1		1
	KS			1		1
BC		1			1	
TX				1	1	
NL	1				1	
FL				1	1	
MO				1	1	
<b>OK Total</b>		<b>7</b>	<b>3</b>	<b>30</b>	<b>24</b>	<b>64</b>
<b>Grand Total</b>		<b>7</b>	<b>3</b>	<b>30</b>	<b>24</b>	<b>64</b>

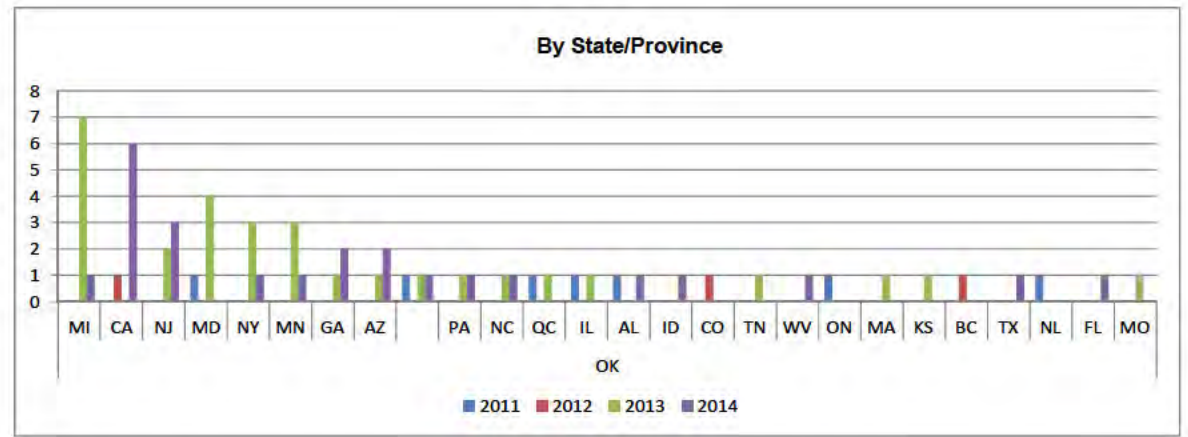

From GCQIS report EFQCB003

Dealer believes the jounce hoses maybe too short on extreme left/right turns





Report Summary Page 1 of 1

---

GCQIS Report Analysis  
**Report Summary**  
 Report 1 of 1  
 Query Name: REPORT RETRIEVAL

Folder Number:  [Report To This Folder](#) [Report To A Folder](#) [Print As Folder\(s\)](#)

[Add Comments](#) [Print](#) [Email](#) [Save](#) [Add Report](#)

Report Detail Section : [View Details](#) [Attachments: 2](#)

Report# :	EFQC8003 FLEET	Received:	06/17/2014
CCRG/EPRC:	S	Date:	06/17/2014
Vehicle:	2013 EXPLORER 4X4 (US02) POLICE ,4 DOOR ,MPV ,1FMSK8AR00G	Build Date:	05/10/2013
Odometer :	9,981 M	Engine:	3.7L DOHC
Transmission:	6F35	Axle:	A/C: YES
Dealers:	USA 60347 Ford Motor Co. Fordgo Flt Svc	Phone#:	
City:	Dearborn	State:	Michigan
Originator:		Country :	USA
Symptom:	6 66 2 87 SP/ST/RO,FLUIDS,BRAKE FLUID,VISIBLE LEAK		
Status:			
VFG:	V86 SUSPENSION & FRAME		
Additional Symptom:			
Fix:	Causal Component :		
Condition Code:			
Fleet Nbr:	NOFIN 00	Fleet Name:	
Phone: ( )	City:	State:	
Spec: KEN MEIER	Spec Phone: ( -317)867 )		
KOED:			
KOEC:			
KOER:			
Comments:	<p><b>CONCER 06/17/2014 08:38AM KEN MEIER M55 - FCSD - FSO</b></p> <p>FLEET CUSTOMER, CALIFORNIA HIGHWAY PATROL, REPORTING CONCERN OF WHEN THE TIRES ARE TURNED OT THE EXTREME LIMITS IN EITHER DIRECTION IT APPEARS TO STRETCH THE BRAKE LINES. DURING NORMAL ROUTINE SERVICE AND INSPECTION, FLEET FOUND BOTH BRAKE LINES STARTING TO LEAK. VEHICLE HAS BEEN SENT TO SUNLAND FORD (SO, CAL.) FOR REPAIR.</p>		

Folder Number:  [Report To This Folder](#) [Report To A Folder](#) [Print As Folder\(s\)](#)

[Add Comments](#) [Print](#) [Email](#) [Save](#) [Add Report](#)

Requester: SMATTHE2 1-Aug-2014  
 Report Summary Ford Proprietary, Private Retention: None  
 Server: FCVWS962 Copyright © 2013 Ford Motor Company. All Rights Reserved.

<https://www.gcqis.dealerconnection.com/gcqi/asp/ReportSummaryMain.asp?pageName=RRR> 8/1/2014

Article Number: 21974  
 Article Type: S  
 Author: SBUELOW  
 Global Concern Number:

## Market(s):

Area Code	Geo Sales Area	Date of Activation	Date of Deactivation
NA	***	07/29/2011	03/14/2012
WD	***	07/29/2011	03/14/2012

## Title:

2011 EXPLORER BUZZ/WHINE NOISE DURING SHIFTS

## Text:

SOME 2011 EXPLORER VEHICLES BUILT BEFORE 6/21/11 MAY EXHIBIT A CONTACT CONDITION BETWEEN THE TRANSMISSION OIL COOLING (TOC) TUBE AND THE BRAKE TUBE NEAR THE DRIVER SIDE FRONT WHEEL WELL CAUSING A BUZZING/HUMMING/WHINING POWERTRAIN NOISE WHILE DRIVING ESPECIALLY DURING TRANSMISSION SHIFTS). INSPECT THE BLACK PLASTIC CLIP ON THE BRAKE TUBE AND VERIFY THAT IT IS FULLY SEATED INTO THE FRAME (THE CLIP IS LOCATED APPROXIMATELY 3.5 INCHES ABOVE AND APPROXIMATELY 6 INCHES BEHIND THE POINT WHERE THE BRAKE TUBE ROUTES NEAR THE TOC TUBE). WITH THE CLIP IN PLACE THERE SHOULD BE APPROXIMATELY 15/16" (24.5 MM) CLEARANCE BETWEEN THE LINES.

## Vehicles:

2011 EXPLORER 4DR (00134)

## Symptom Code:

600000 DRIVELINE  
 601000 DRIVELINE AUTO TRANS UPSHIFT CONCERNS  
 604000 DRIVELINE OTHER AUTO TRANS CONCERNS  
 697997 DRIVELINE NOISE CONCERNS  
 700000 NOISE AND VIBRATION  
 702000 NVH OTHER NOISE CONCERNS  
 702100 NVH NOISE CONCERN - FRONT

## Global Customer Symptom Codes:

Category	Q1	Q2	Q3	Full Code
Start/Run/Move				4***
Start/Run/Move	Noise			449***
Start/Run/Move	Noise	Running/Stopping		4481**
Start/Run/Move	Noise	Running/Stopping	Intermittent	448129
Start/Run/Move	Noise	Moving/Driving		4482**
Start/Run/Move	Noise	Moving/Driving	Intermittent	448239
Stop/Steer/Ride				6***
Stop/Steer/Ride	Noise			668***
Stop/Steer/Ride	Noise	Front		6683**
Stop/Steer/Ride	Noise	Front	Intermittent	668339

## Audit Comments:

Area Code	Geo Sales Area	Comments	Old Date of Deactivation	New Date of Deactivation	CSMD
NA	***	THIS MESSAGE WAS SUPERCEDED BY 22256	07/29/2011	03/14/2012	GSMITH43
WD	***	THIS MESSAGE WAS SUPERCEDED BY 22256	07/29/2011	03/14/2012	GSMITH43



Article Number: 22266  
 Article Type: S  
 Author: SBUELOW  
 Global Concern Number: 074-2012-0005

## Market(s):

Area Code	Geo Sales Area	Date of Activation	Date of Deactivation
NA	***	09/15/2012	09/23/2012
WD	***	09/15/2012	09/23/2012

## Title:

2011-2013 EXPLORER BUZZ/WHINE NOISE DURING SHIFTS

## Text:

SOME 2011-2013 EXPLORER VEHICLES MAY EXHIBIT A CONTACT CONDITION BETWEEN THE TRANSMISSION OIL COOLING (TOC) TUBE AND THE BRAKE TUBE NEAR THE DRIVER SIDE FRONT WHEEL WELL CAUSING A BUZZING/HUMMING/WHINING POWERTRAIN NOISE WHILE DRIVING(ESPECIALLY DURING TRANSMISSION SHIFTS). INSPECT THE BLACK PLASTIC CLIP ON THE BRAKE TUBE AND VERIFY THAT IT IS FULLY SEATED INTO THE FRAME (THE CLIP IS LOCATED APPROXIMATELY 3.5 INCHES ABOVE AND APPROXIMATELY 6 INCHES BEHIND THE POINT WHERE THE BRAKE TUBE ROUTES NEAR THE TOC TUBE), WITH THE CLIP IN PLACE THERE SHOULD BE APPROXIMATELY 15/16" (24.5 MM) CLEARANCE BETWEEN THE LINES.

## Vehicle(s):

2011-2013 EXPLORER 4DR (00134)

## Symptom Code:

700000 NOISE AND VIBRATION  
 700000 NVH OTHER NOISE CONCERNS  
 702100 NVH NOISE CONCERN - FRONT

## Global Customer Symptom Codes:

Category	Q1	Q2	Q3	Full Code
Start/Run/Move				4***
Start/Run/Move	Noise			448***
Start/Run/Move	Noise	Running/Stopping		4481**
Start/Run/Move	Noise	Running/Stopping	Intermittent	448129
Start/Run/Move	Noise	Moving/Driving		4482**
Start/Run/Move	Noise	Moving/Driving	Intermittent	448299
Stop/Steer/Ride				6***
Stop/Steer/Ride	Noise			668***
Stop/Steer/Ride	Noise	Front		6683**
Stop/Steer/Ride	Noise	Front	Intermittent	668399

## Audit Comments:

Area Code	Geo Sales Area	Comments	Old Date of Deactivation	New Date of Deactivation	CSRID
NA	***	THIS MESSAGE WAS SUPERCEDED BY 22519	09/15/2012	09/23/2012	GSMITH63
WD	***	THIS MESSAGE WAS SUPERCEDED BY 22519	09/15/2012	09/23/2012	GSMITH63

**Article Number:** 22519  
**Article Type:** S  
**Author:** PCAMPAU  
**Global Concern Number:** 074-2012-0005

**Market(s):**

Area Code	Geo Sales Area	Date of Activation	Date of Deactivation
EU	RUS	07/29/2012	09/24/2016
NA	***	09/24/2012	09/24/2016
WD	***	09/24/2012	09/24/2016

**Title:**

2011-2013 EXPLORER BUILT ON OR BEFORE 08/31/2012 - BUZZ/WHINING/MOANING NOISE DURING SHIFTS AND IN 3RD-6TH GEARS

**Text:**

SOME 2011-2013 EXPLORER VEHICLES BUILT ON OR BEFORE 08/31/2012 MAY EXHIBIT A CONTACT CONDITION BETWEEN THE TRANSMISSION OIL COOLING (TOC) TUBE AND THE BRAKE TUBE NEAR THE DRIVER SIDE FRONT WHEEL WELL CAUSING A BUZZING/HUMMING/WHINING/MOANING POWERTRAIN NOISE WHILE DRIVING 3RD THROUGH 6TH GEAR/ESPECIALLY DURING TRANSMISSION SHIFTS). INSPECT THE BLACK PLASTIC CLIP ON THE BRAKE TUBE AND VERIFY THAT IT IS FULLY SEATED INTO THE FRAME (THE CLIP IS LOCATED APPROXIMATELY 3.5 INCHES ABOVE AND APPROXIMATELY 6 INCHES BEHIND THE POINT WHERE THE BRAKE TUBE ROUTES NEAR THE TOC TUBE). WITH THE CLIP IN PLACE THERE SHOULD BE APPROXIMATELY 15/16" (24.5 MM) CLEARANCE BETWEEN THE LINES.

**Vehicles:**

2011-2013 EXPLORER 4DR (00134)

**Symptom Code:**

500000 DRIVELINE  
 501000 DRIVELINE AUTO TRANS UPSHIFT CONCERNS  
 502000 DRIVELINE AUTO TRANS DOWNSHIFT CONCERNS  
 503000 DRIVELINE AUTO TRANS ENGAGEMENT CONCERNS  
 503200 DRIVELINE AUTO TRANS SHIFT LEVER/LINKAGE  
 504000 DRIVELINE OTHER AUTO TRANS CONCERNS  
 507997 DRIVELINE NOISE CONCERNS  
 700000 NOISE AND VIBRATION  
 702000 NVH OTHER NOISE CONCERNS  
 702100 NVH NOISE CONCERN - FRONT

**Global Customer Symptom Codes:**

Category	Q1	Q2	Q3	Full Code
Start/Run/Move				448***
Start/Run/Move	Noise			448***
Start/Run/Move	Noise	Running/Standing		4481**
Start/Run/Move	Noise	Running/Standing	Always	448100
Start/Run/Move	Noise	Running/Standing	Cold	448112
Start/Run/Move	Noise	Running/Standing	Hot	448134
Start/Run/Move	Noise	Running/Standing	Intermittent	448139
Start/Run/Move	Noise	Moving/Driving		4482**
Start/Run/Move	Noise	Moving/Driving	Always	448200
Start/Run/Move	Noise	Moving/Driving	Cold	448212
Start/Run/Move	Noise	Moving/Driving	Hot	448234
Start/Run/Move	Noise	Moving/Driving	Intermittent	448239
Stop/Steer/Idle				668***
Stop/Steer/Idle	Noise			668***

Illustration of part from on-line parts catalog

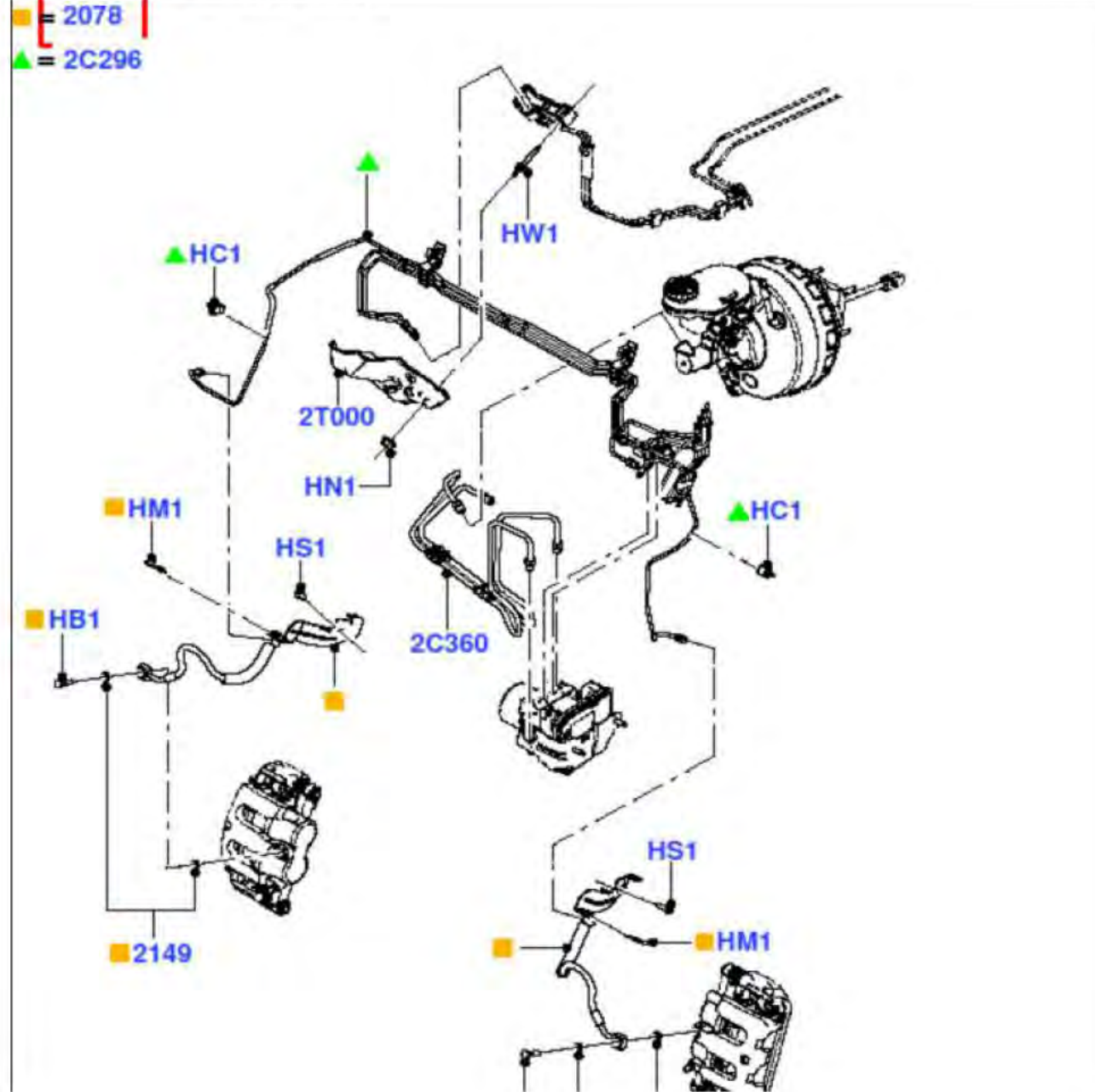



2060615  
11-2010  
UB  
F0225001-02

© Copyright, 2010, Ford Motor Company Limited

Useage/application per on-line parts catalog

Ford Catalog Advantage Application - Welcome smathe 2 - Textual Search Page 1 of 1

Shortcut Search    Language: English | Currency: USD

[DMS](#) [Home](#) [Find Price](#) [Bookmark](#) [Links](#) [Settings](#) [Support](#) [About](#) [Help](#) [Log Out](#)

Textual Search **Illustrated Index** **Shopping** TUB Explorer 2013 ??????????????????

**Search TUB Explorer**

Base  Description  SPN  Motorcraft  
 Associated Part No.

Search:

**Cross Reference Search**

EPN:  -  -

**VIN Results** Search Results

Results 1- 1 out of 1 Result Pages: [1]

Callout No.	Description	Section
2078	Hose Assy - Brake	15 FRONT BRAKE LINES, 2011/ From: 11/01/2010

| Price: FCA Retail

Hide Columns

**Results 1 - 2 out of 2**      **Result Pages :** [ 1 ]

<input type="checkbox"/> SPN	Motorcraft	Application Info	Model Year	Price	Qty	Indicators
<input type="checkbox"/> CBSZ-2078-B		LH, From: 11/01/2010 To: 06/23/2014 2011/2015	2011/2015	48.25	1	
<input type="checkbox"/> CBSZ-2078-A		RH, From: 11/01/2010 2011/	2011/	48.25	1	

<http://web.fcac.dealerconnection.com/Ford/VehicleSelector.do?action=setVehicleByModel&CategoryId=2&C...> 7/23/2014

## 2011-2014 Explorer

Fleet Service Hotline received approximately 10-12 reports from a Police fleet in the Baltimore/Washington DC area which indicated they had several 2013 Explorer vehicles in their fleet that had developed leaks in the jounce hoses.

CDR search of 2011-2014 Explorer; Chassis service brakes with symptoms; "bulging/swollen line or hose; damage-chafed/excessive wear; damage-cracked/fractured/split; damage-cut/torn/frayed; leak-fluid;"

Read the reports with key words that included; leak, brake, fluid, hose, line, etc.

I attempted to identify the alleged leaking component. e.g. caliper, master cylinder, jounce hose, etc.

Sort Field 3 attempts to identify the location of the alleged leaking component, e.g. lf, rf, lr, rr, as applicable and discernable based on the customer and technician comments and not necessarily based on alleged causal base part number.

Reports where Customer or Technician comments indicate a leak in the brake system (not vacuum)

Count of ECI Record ID Sort Field One	Source Code	Model Year				Grand Total
		2011	2012	2013	2014	
1	AWS	185	134	224	71	614
	FMC360	1	3	2		6
	GCQIS Ford	14	5	25	2	46
	MORSICUDL	1				1
<b>1 Total</b>		<b>201</b>	<b>142</b>	<b>249</b>	<b>75</b>	<b>667</b>
<b>Grand Total</b>		<b>201</b>	<b>142</b>	<b>249</b>	<b>75</b>	<b>667</b>

FLUID  
LEAKS

Component/source of the alleged brake fluid leak (not vacuum)

Count of ECI Record ID Sort Field One	Description of leak	Model Year				Grand Total
		2011	2012	2013	2014	
1	at caliper	63	84	93	25	265
	into booster	46	17	57	10	130
	(blank)	13	18	31	3	65
	at hcu	31	13	10	7	61
	at mc	36	4	12	1	53
	at jounce hose	6	2	22	13	43
	at jounce hose fitting	2	1	8	11	22
	not stated	1	2	2	2	7
	at cap		1	3	1	5
	bulge in hose			4		4
	at banjo bolt			2	1	3
	hard line in engine compartment			2	1	3
	hose split			1		1
	rub on toc line	1				1
	jounce hose stretch			1		1
	at brake pipe	1				1
	Brake line	1				1
	no part number provided					
	pin hole leak				1	1
	<b>1 Total</b>		<b>201</b>	<b>142</b>	<b>249</b>	<b>75</b>
<b>Grand Total</b>		<b>201</b>	<b>142</b>	<b>249</b>	<b>75</b>	<b>667</b>

FLUID LEAKS

74 reports on 64 unique VINs

Alleged Brake line/hose leak (not vacuum)

Count of ECI Record ID Sort Field One	Description of leak or source/cause	Model Year				Grand Total
		2011	2012	2013	2014	
1	hose split			1		1
	jounce hose stretch			1		1
	at banjo bolt			2	1	3
	bulge in hose			4		4
	at jounce hose fitting	2	1	8	11	22
	at jounce hose	6	2	22	13	43
<b>1 Total</b>		<b>8</b>	<b>3</b>	<b>38</b>	<b>25</b>	<b>74</b>
<b>Grand Total</b>		<b>8</b>	<b>3</b>	<b>38</b>	<b>25</b>	<b>74</b>

FLUID LEAKS  
FROM AROUND  
JOUNCE  
HOSE

**By Production Date**

Description of leak or source/cause (Multiple Items)

Count of ECI Record ID

Dupe Vin 2	Years	Production Date	Total	
OK	2011	Jan	1	
		Feb	2	
		Mar	2	
		Apr	1	
		May	2	
		Jun	1	
		Jul	1	
		Aug	1	
		Sep	2	
		Oct		
		Nov		
		Dec		
	2012	Jan	11	
		Feb	1	
		Mar	1	
		Apr	1	
		May	6	
		Jun	2	
		Jul	2	
		Aug		
		Sep		
		Oct		
		Nov		
		Dec		
	2013	Jan	1	
		Feb	1	
		Mar	2	
		Apr	2	
		May	4	
		Jun	3	
		Jul	2	
		Aug	1	
		Sep	1	
		Oct	2	
		Nov	1	
		Dec	2	
	2014	Jan	2	
		Feb	4	
		Mar	4	
		Apr		
		May		
		Jun		
		Jul		
		Aug		
		Sep		
		Oct		
		Nov		
		Dec		
	OK Total			64
	Grand Total			64

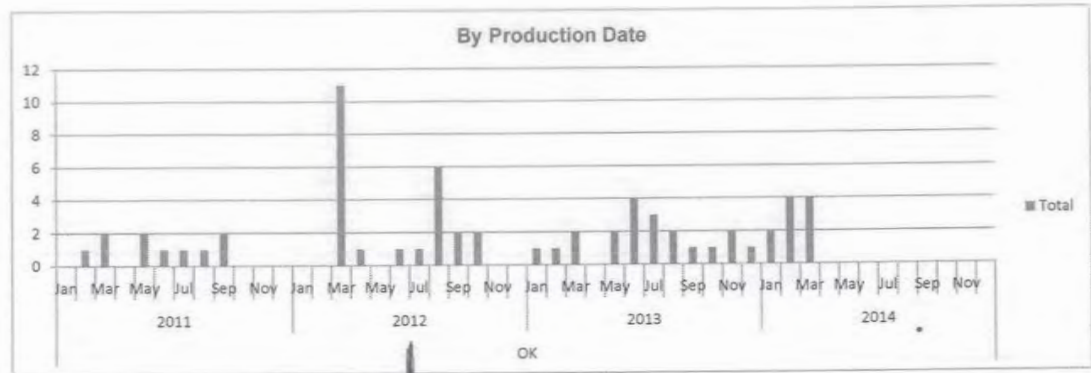

<b>By Mileage at Time of Repair/Report</b>	
Sort Field One	1
Description of leak or source/cause	(Multiple Items)

Count of ECI Record ID	Mileage	Model Year				Grand Total
		2011	2012	2013	2014	
OK	0-9999	2		12	22	36
	10000-19999	2		5	2	9
	20000-29999	2	1	4		7
	30000-39999	1	1	6		8
	40000-49999			3		3
	50000-59999		1			1
<b>OK Total</b>		<b>7</b>	<b>3</b>	<b>30</b>	<b>24</b>	<b>64</b>
<b>Grand Total</b>		<b>7</b>	<b>3</b>	<b>30</b>	<b>24</b>	<b>64</b>

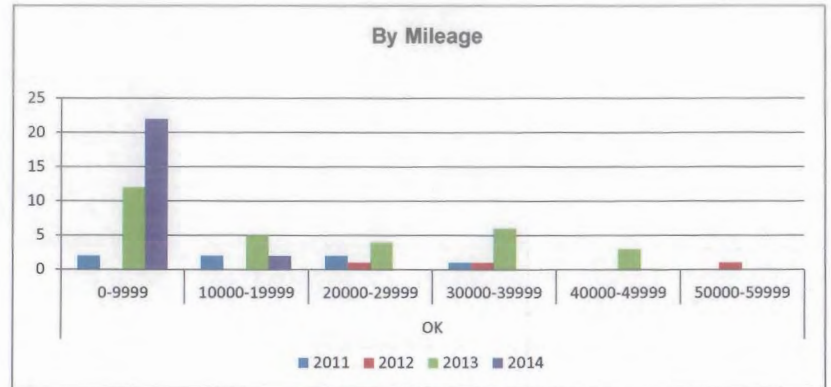



Time In Service	
Sort Field One	1
Description of leak or source/cause	(Multiple Items)

Count of Dupe Vin 2	ECI Record ID Time In Service	Model Year				Grand Total
		2011	2012	2013	2014	
OK	0	1		1	4	6
	1			2	5	7
	2				3	3
	3			5	3	8
	4				3	3
	5				1	1
	6			2		2
	7	1			1	2
	8	1			1	2
	9			2	1	3
	10				1	1
	11	1		1		2
	12					
	13			2		2
	14			1		1
	15			1		1
	16					
	17					
	18					
	19		1			1
	20					
	21			2		2
	22					
	23		1	1		2
	24					
	25					
	26	1		1		2
	27			1		1
	28					
	29			1		1
	30		1			1
	31					
	32					
	33					
	34					
	35					
	36	1				1
	37	1				1
	(blank)			8	1	9
OK Total		7	3	30	24	64
Grand Total		7	3	30	24	64

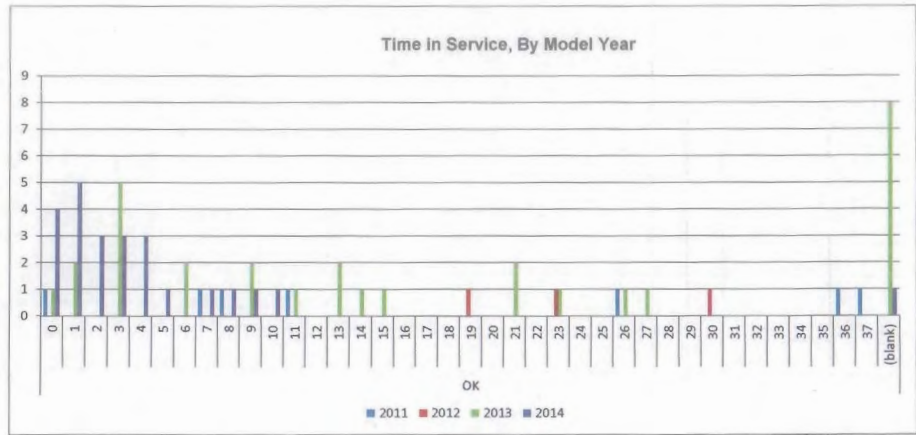

**By State/Province**

This information can be misleading as several of the GCQIS reports indicate the dealer name/address as Ford Fleet Services in Dearborn, MI (as Dealer Name; FORD MOTOR CO. FPSDGO FLT SVC)

Sort Field One 1  
Description of leak or source/cause (Multiple Items)

Dupe Vin 2	Dealer State/Prov	Count of ECI Record ID				Grand Total
		2011	2012	2013	2014	
OK	MI			7	1	8
	CA		1			1
	NJ			2	3	5
	MD	1		4		5
	NY			3	1	4
	MN			3	1	4
	GA			1	2	3
	AZ			1	2	3
	PA	1		1	1	3
	NC			1	1	2
	QC			1	1	2
	IL	1		1		2
	AL	1			1	2
	ID				1	1
	CO		1			1
	TN			1		1
	WV				1	1
	ON	1				1
	MA			1		1
	KS			1		1
	BC		1			1
	TX				1	1
	NL	1				1
	FL				1	1
	MO			1		1
<b>OK Total</b>		<b>7</b>	<b>3</b>	<b>30</b>	<b>24</b>	<b>64</b>
<b>Grand Total</b>		<b>7</b>	<b>3</b>	<b>30</b>	<b>24</b>	<b>64</b>

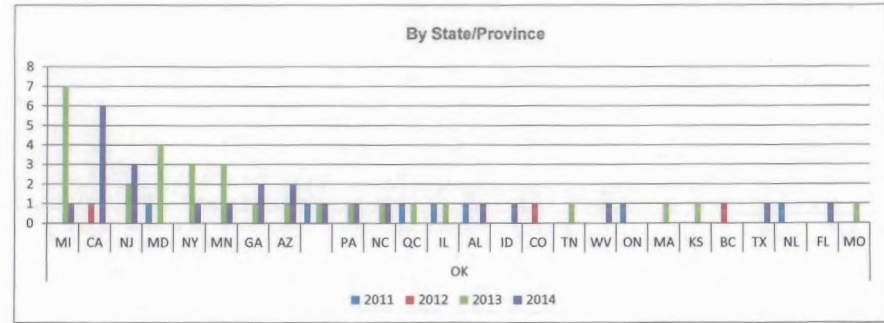

From GCQIS report EFQCB003

Dealer believes the jounce hoses maybe too short on extreme left/right turns



---

**From:** [REDACTED] s  
**Sent:** Monday, January 16, 2012 10:38 AM  
**To:** [REDACTED]  
**Subject:** 2013 U502 Tire Package

[REDACTED]

Can you find out the DC for the 2013 composite wheel packages? Once we have this, Tony will overlay our design and determine that we are covered with our current wheel paddle.

We tried the 18" tires, and found no issues. It seems that the 18" wheels/tires that came with the vehicle are smaller than the paddle profile.

Thank You,

[REDACTED]

[REDACTED]

[REDACTED]



# Concern Driven Reporting

# Search Result

smatthe2 / Ford LM  
Release 12.0.1  
Release Date: Sept  
14, 2010

[Search](#) >> [Search Result](#) >> [Search Summary](#) >> [Report Detail](#) >> [Vehicle Report History](#)  
>> [Chart Analysis](#)

Welcome  
Search  
BO Adhoc Query

Selection Summary	
make	Ford LM;
model year	2014; 2013; 2012; 2011;
vehicle line	EXPLORER;
pnbb code	2078;

Global Folder Search  
My Inbox  
My Folders  
Manage CA Assignments  
Manage Folders

### Chart Analysis:

None

[Report List to Excel](#)

[Report Summary](#)

Tread Act Early Warning Reporting  
View NHTSA Archive  
Create AI Extract

Commodity Category - LV1	Commodity Counts	Significant Events	CQIS Safety
<b>AWS (512) UNIQUE ECI RECORD COUNTS</b>			
chassis - service brakes	<input checked="" type="checkbox"/> 512		
<b>chassis - Subtotal</b>	<input checked="" type="checkbox"/> <b>512</b>		

Triggers  
Dashboard  
Create/Update

Commodity Category - LV1	Commodity Counts	Significant Events	CQIS Safety
<b>Across All Source Systems (512) UNIQUE ECI RECORD COUNTS</b>			
<b>Total - Total</b>	<input checked="" type="checkbox"/> <b>512</b>	<b>0</b>	<b>0</b>

[Report List to Excel](#)

[Report Summary](#)

[Print to PDF](#)

Hazard Request Manager  
Hazard Result Manager

IRIS  
WPRC  
Feedback  
Help Docs

21801  
line 10842  
2822

SSM 22519  
21924  
21974  
22266  
BROADCAST MSA → 5128

Disclaimer: This data is for use as one of several potential "awareness" indicators for the Ford Motor Co. Enhanced Concern Identification System. It is unverified, draft, summary data generated from a computer "word search" of customer and technician symptom comments. Supplier data, technician and customer comments are unverified and actual root cause of any potential issue is not established by this summary.

Contact: CDR HELP
Copyright © 2001 Ford Motor Co. All Rights Reserved.
Major Release 12.0.1
Release Date: Sept 14,2010



**Concern Driven Reporting**

**Search Result**

smatthe2 / Ford LM  
Release 12.0.1  
Release Date: Sept  
14,2010

[Search](#) >> [Search Result](#) >> [Search Summary](#) >> [Report Detail](#) >> [Vehicle Report History](#)  
>> [Chart Analysis](#)

Welcome  
Search  
BO Adhoc Query

Global Folder  
Search  
My Inbox  
My Folders  
Manage CA  
Assignments  
Manage Folders

Tread Act Early  
Warning  
Reporting  
View NHTSA  
Archive  
Create AI Extract

Triggers  
Dashboard  
Create/Update

Hazard Request  
Manager  
Hazard Result  
Manager

IRIS  
WPRC  
Feedback  
Help Docs

Selection Summary	
make	Ford LM;
vehicle line	EXPLORER;
model year	2014; 2013; 2012; 2011;
commodity category	chassis;
commodity level1	service brakes;
symptoms	bulging/swollen line or hose; damage-chafed/excessive wear; damage-cracked/fractured/split; damage-cut/torn/frayed ; leak-fluid;

**Chart Analysis:**

None

[Report List to Excel](#)

[Report Summary](#)

Commodity Category - LV1	Commodity Counts	Significant Events	CQIS Safety
<b>AWS (10626) UNIQUE ECI RECORD COUNTS</b>			
chassis - service brakes	<input checked="" type="checkbox"/> 10626	<input type="checkbox"/> 263	
<b>chassis - Subtotal</b>	<input checked="" type="checkbox"/> <b>10626</b>	<input type="checkbox"/> <b>263</b>	
<b>GCQIS Ford (368) UNIQUE ECI RECORD COUNTS</b>			
chassis - service brakes	<input checked="" type="checkbox"/> 368	<input type="checkbox"/> 10	<input type="checkbox"/> 25
<b>chassis - Subtotal</b>	<input checked="" type="checkbox"/> <b>368</b>	<input type="checkbox"/> <b>10</b>	<input type="checkbox"/> <b>25</b>
<b>MORS\CUDL (68) UNIQUE ECI RECORD COUNTS</b>			
chassis - service brakes	<input checked="" type="checkbox"/> 68	<input type="checkbox"/> 2	
<b>chassis - Subtotal</b>	<input checked="" type="checkbox"/> <b>68</b>	<input type="checkbox"/> <b>2</b>	
<b>FMC360 (149) UNIQUE ECI RECORD COUNTS</b>			
chassis - service brakes	<input checked="" type="checkbox"/> 149	<input type="checkbox"/> 8	
<b>chassis - Subtotal</b>	<input checked="" type="checkbox"/> <b>149</b>	<input type="checkbox"/> <b>8</b>	
<b>QQRS Ford (12) UNIQUE ECI RECORD COUNTS</b>			
chassis - service brakes	<input checked="" type="checkbox"/> 12		

<b>chassis - Subtotal</b>	<input checked="" type="checkbox"/> 12		
<b>Commodity Category - LV1</b>	<b>Commodity Counts</b>	<b>Significant Events</b>	<b>CQIS Safety</b>
<b>VOQ Ford (5) UNIQUE ECI RECORD COUNTS</b>			
chassis - service brakes	<input checked="" type="checkbox"/> 5	<input type="checkbox"/> 1	
<b>chassis - Subtotal</b>	<input checked="" type="checkbox"/> 5	<input type="checkbox"/> 1	
<b>Commodity Category - LV1</b>	<b>Commodity Counts</b>	<b>Significant Events</b>	<b>CQIS Safety</b>
<b>Across All Source Systems (11228) UNIQUE ECI RECORD COUNTS</b>			
<b>Total - Total</b>	<input checked="" type="checkbox"/> 11228	<input type="checkbox"/> 284	<input type="checkbox"/> 25

[Report List to Excel](#)

[Report Summary](#)

[Print to PDF](#)

Disclaimer: This data is for use as one of several potential "awareness" indicators for the Ford Motor Co. Enhanced Concern Identification System. It is unverified, draft, summary data generated from a computer "word search" of customer and technician symptom comments. Supplier data, technician and customer comments are unverified and actual root cause of any potential issue is not established by this summary.

Contact: CDR HELP
Copyright © 2001 Ford Motor Co. All Rights Reserved.
Major Release 12.0.1
Release Date: Sept 14,2010



---

**From:** [REDACTED]  
**Sent:** Thursday, January 12, 2012 4:20 PM  
**To:** [REDACTED]  
**Subject:** COMMON DURABILITY INCIDENT REPORTING

Is this the TVM hose that Hitachi presented yesterday? If so, Wendy this is why I stressed the importance of the Ford D&R buying off on the jounce study. If you watch the video, the brake hose bracket is flexing at the body. This hose is pulled tight. Either the jounce study missed something or suspension/steering travel changed after the study and brakes was not notified. Must find out asap to correct the right thing. On Dave's durability review tomorrow.

<http://www.duris.ford.com/pls/duris/incident.report?incidentcode=695520>

[REDACTED]  
Supervisor - Flexible Components  
Ford Global Core Brake Engineering

[REDACTED]  
"The trouble with quotes on the Internet is that it's difficult to determine whether or not they are genuine" - Abraham Lincoln

---

**From:** [REDACTED]  
**Sent:** Wednesday, July 30, 2014 2:03 PM  
**To:** [REDACTED]  
**Subject:** DC trip

Nothing unique we could determine with the DC fleet. I talked to the NHTSA investigators too. I will debrief when I return.

Thank You

[REDACTED]  
Brake Supervisor, V363, B299, D258, D385, D47X, U502, Econoline, C489  
FN3 – HS015  
3 [REDACTED]



*10/25  
2012/2015*

Count of Claim Key CCC	VIN	Produced On	Model Year 2011
L63 - BRAKE FLUID LEAK	1FM5K7B81EGC	5/22/2014	
	1FM5K7B8XDGC	2/17/2013	
	1FM5K7D82EGA	8/26/2013	
	1FM5K7D83DGB	9/29/2012	
	1FM5K7D83EGA	7/15/2013	
	1FM5K7D89DGB	8/9/2012	
	1FM5K7D93DGA	7/14/2012	
	1FM5K7F81EGB	1/26/2014	
	1FM5K7F89EGA	6/18/2013	
	1FM5K8AR3DGA	3/21/2012	
	1FM5K8AR5DGA	3/22/2012	
	1FM5K8ARXDGA	3/15/2012	
	1FM5K8B83DGA	6/13/2012	
	1FM5K8B85EGB	3/4/2014	
	1FM5K8B88EGC	3/26/2014	
	1FM5K8D81DGA	3/29/2012	
	1FM5K8D82EGA	7/14/2013	
	1FM5K8D83DGA	3/5/2012	
	1FM5K8D83EGB	3/21/2014	
	1FM5K8D86DGA	5/23/2012	
	1FM5K8D86DGC	3/1/2013	
	1FM5K8D87EGA	9/9/2013	
	1FM5K8F85DGA	7/28/2012	
	1FM5K8F88EGA	6/27/2013	
	1FM5K8GT9EGB	2/26/2014	
	1FMHK7F86CGA	11/9/2011	
	1FMHK8D84BGA	7/13/2011	1
	1FMHK8D85BGA	4/5/2011	1
	1FMHK8D86BGA	1/18/2011	1
	1FMHK8F80BGA	5/4/2011	1
	1FMHK8F83BGA	5/24/2011	1
	1FMHK8F85BGA	4/11/2011	1
L63 - BRAKE FLUID LEAK Total			6
Grand Total			6

Dir Code 60347

Count of ECI Record ID	
ECI Record ID	Total
750554593 ✓	1
750554594 ✓	1
750554595 ✓	1
750554596 -	1
750554597 ✓	1
750554598 ✓	1
750554599 ✓	1
750554600 -	1
750554601 -	1
750554602 -	1
<b>Grand Total</b>	<b>10</b>

---

**From:** [REDACTED]  
**Sent:** Monday, July 21, 2014 9:36 AM  
**To:** [REDACTED]  
**Subject:** FW: Brake hose- Need Resolution  
**Attachments:** FR 284 Utilities-.xlsx  
**Importance:** High

[REDACTED],  
Pete Williams and his team are responsible for the brakes on these programs now.

Regards,

[REDACTED],  
Supervisor, Unibody Brake Systems Engineering

Cell Phone # [REDACTED]  
[REDACTED]

[REDACTED] [REDACTED]  
[REDACTED] [REDACTED]  
**Sent:** Monday, July 21, 2014 8:42 AM

**To:** [REDACTED]  
**Subject:** FW: Brake hose- Need Resolution  
**Importance:** High

Please review.

**-The Customer Defines Quality-**

[REDACTED] - *Ford Motor Company*

FCSD Program Manager-  
Taurus/SHO/MKS/Explorer/Police  
Chicago Assembly PVT Office  
[REDACTED]

"If I had asked people what they wanted, they would have said faster horses."  
— [REDACTED]

---

**From:** [REDACTED]  
**Sent:** Friday, July 18, 2014 7:55 AM  
**To:** [REDACTED] (E.)

**Subject:** FW: Brake hose- Need Resolution  
**Importance:** High

What are you seeing on your end regarding this?

**From:** [REDACTED]

**Sent:** Friday, July 18, 2014 7:43 AM

**To:** [REDACTED]

**Subject:** RE: Brake hose- Need Resolution  
**Importance:** High

Folks,

Need this escalated so we can get a resolution- before someone is injured or worse. This is a major safety issue – particularly with this type of vehicle application- No brakes, unable to stop the vehicle is the result after the hose failure--

MPD is continuing to have brake hose failures on the Ford PI Utility units, the 2 part numbers affected are: DB5Z-2078B RF --- DB5Z-2078A LF.

I have looped Ford in on this before, sent hoses to Ford to analyze-

**Has there been a reason identified as the failure ?? and I so, what is the plan of action ?**

The failures started in Dec 2013, and are continuing to fail, as of yesterday another unit towed in for no brakes- pedal goes to the floor-- I now have 2 vehicles, that both RF and LF hoses that have failed— VINS:

1FM5K8ARXDC [REDACTED] & 1FM5K8AR7D [REDACTED]

**What has been the part issue for these hoses-- DB5Z-2078B RF --- DB5Z-2078A LF ??**

Info I have found:

- Looking at the vin sequence --- these were all produced under RPN- FR-284, the MSO were all received March 20<sup>th</sup> -27<sup>th</sup>, looks like production was all in March 2012-- vehicles arrived to MPD on April 9<sup>th</sup> – 23<sup>rd</sup> .
- My 2<sup>nd</sup> order of Utilities in 2012, RPN- GP-129 were received in Sept- to date no hose failures on these Utilities/vins

Extremely High Potential for a vendor supply issue for any produce in this time frame—I am attaching all the vins for this RPN-

MPD has been inspecting these hoses at the pm service- yet we continue to have hose failures -

*Before someone is involved in and accident- injury or other-, during a chase or normal operation, I am pulling these into the shop to replace both brake hoses (if hasn't been completed already)*

- **I will be asking Ford for assistance on the replacement of these hoses---**  
What other information do you need from MPD ?

**VIN'S-Date location & miles for brake hoses:**

- 1FM5K8AR7DG [REDACTED] LF brake hose-- miles 34,194 Date 4-23-14 - TOW IN NO BRAKES / LEAKING – LF brake hose
- 1FM5K8AR3DG [REDACTED] -- brake hose –date 4-9-14 mi 33,302 (this was not warranty-per Ford dealer, hose was twisted)
- 1FM5K8AR5DG [REDACTED] —LF brake hose—date 12-17-13 mi 26,147—Complaint was brakes low -cause was LEFT FRONT BRAKE HOSE LEAKING
- 1FM5K8AR0DG [REDACTED] —RF Brake hose —date -12-24-13 mi 16,511 - Complaint was brakes was fading – cause send To the dealer for right front brake hose leaking, lower radiator hose leaking. Correction dealer replaced rf hose and lower radiator hose
- 1FM5K8AR1DG [REDACTED] -- RF brake hose –date 2-24-14- mi- 30,872 Complaint : VEHICLE TOWED IN, BRAKES GO TO THE FLOOR Cause: right brake hose leaking

- 1FM5K8AR0DG [REDACTED] —LF brake hose-Date - 2-25-14 mi 39,369 Complaint : tow in in- No start- Cause : found l/f brake hose leaking during safety inspection of the vehicle
- 1FM5K8ARXDG [REDACTED] date 4-28-14, DC8218-DGA27064 Mi 45430 100471 DB5Z2078A LEFT hose , Complaint : BRAKES ARE VERY LOW AND NEED TO BE REPLACED Cause : NEEDS A BRAKE HOSE....WFP. checked for no brake split in brake hose leaking . replaced
- 1FM5K8ARXDG [REDACTED] - Date 5-14-14 miles 46,525 - same vehicle RF hose was replaced- on 5-14-14 Complaint: PM Service due- found bubble in hose during inspection – Cause PASSDOWN: RIGHT FRONT BRAKE HOSE HAS BUBBLE correction: send to dealer for r/f brake hose / P.T. U NOISE
- 1FM5K8AR6DG [REDACTED] DC87213 7-7-14 miles 39,075- towed in No brakes- rf brake hose leaking- loss of fluid no brakes
- 1FM5K8AR7DG [REDACTED] Ro102219 Date 7/1/14- found during PM service- LF brake hose leaking, miles 42.802
- 1FM5K8AR7DG [REDACTED] RO# 102595, Date- 7-17-14, miles- 43,891,— towed in no brakes- pedal goes to the floor RF brake hose blown, leaking fluid
- 1FM5K8AR6DG [REDACTED] RO100829 date 5-9-14 miles 41,504 -- tow in No brakes -- replaced RF hose
- 1FM5K8AR3DG [REDACTED] date 6-14-14-- LF brake hose-- Dealer replaced Cheaseake Ford replaced towed in no brakes--29,789- towed in miles 29,789

[REDACTED]  
 DC Metropolitan Police Department  
 Fleet Manager

[REDACTED] cell

*"If I had asked people what they wanted, they would have said faster horses." — Henry Ford*

---

**From:** [REDACTED]  
**Sent:** Thursday, June 05, 2014 10:21 AM  
**To:** [REDACTED]  
**Cc:** [REDACTED]  
**Subject:** RE: Brake hose

[REDACTED] – Thank you!  
 [REDACTED] - Please let us know if you need further info

[REDACTED]  
 PVT Police Quality Program Management  
 Chicago Assembly Plant /Ford Police Programs  
 Cell: [REDACTED]  
 [REDACTED]

---

**From:** [REDACTED]  
**Sent:** Thursday, June 05, 2014 7:53 AM  
**To:** [REDACTED]  
**Subject:** RE: Brake hose

[REDACTED]  
 Here is what I can pull from the repair orders hope this helps –



We are checking every vehicle now for the brake hose conditions

1FM5K8AR3DG [REDACTED] -- brake hose – 4-9-14 mi 33,302 (this was not warranty-per Ford dealer, hose was twisted by techs installing brake pads)

1FM5K8AR5DG [REDACTED] —LF brake hose—12-17-13 mi 26,147— **Complaint was brakes low** -cause was LEFT FRONT BRAKE HOSE LEAKING

1FM5K8AR0DG [REDACTED] —RF Brake hose --12-24-13 mi 16,511 - **Complaint was brakes was fading** —cause send To the dealer for right front brake hose leaking, lower radiator hose leaking. Correction dealer replaced rf hose and lower radiator hose

1FM5K8AR1DG [REDACTED] -- RF brake hose --2-24-14- mi- 30,872 **Complaint : VEHICLE TOWED IN, BRAKES GO TO THE FLOOR** Cause: right brake hose leaking

1FM5K8AR0DG [REDACTED] —LF brake hose-- 2-25-14 mi 39,369 **Complaint : tow in in- No start- Cause : found l/f brake hose leaking during safety inspection of the vehicle**

1FM5K8ARXDG [REDACTED] - DC8218 DGA27064 Mi 45430 100471 DB5Z2078A LEFT hose 4-28-14

**Complaint** : BRAKES ARE VERY LOW AND NEED TO BE REPLACED **Cause** : NEEDS A BRAKE HOSE....WFP. checked for no brake split in brake hose leaking . replaced

1FM5K8ARXDG [REDACTED] - 5-14-14 miles 46,525 - same vehicle

RF hose was replaced- on 5-14-14 Complaint: PM Service due- found bubble in hose during inspection – Cause PASSDOWN: RIGHT FRONT BRAKE HOSE HAS BUBBLE correction: send to dealer for r/f brake hose / P.T. U NOISE

Greg Hester

DC Metropolitan Police Department

Fleet Manager

[REDACTED]

*"If I had asked people what they wanted, they would have said faster horses." — Henry Ford*

---

**From:** [REDACTED]

**Sent:** Wednesday, June 04, 2014 10:01 AM

**To:** [REDACTED]

**Cc:** [REDACTED]

**Subject:** RE: Brake hose

[REDACTED]

Thank you for sending in the brake hoses. Our team in Dearborn has been reviewing and evaluating the hoses the last couple of weeks.

Can you provide further information regarding the duty cycle, driving/roads conditions, at failure what was noticed/observed, etc? Any further info will help regarding the analysis.

[REDACTED] Program Management  
Chicago Assembly Plant /Ford Police Programs  
Cell: 3 [REDACTED]  
Email: [REDACTED]

---

**From:** [REDACTED]

**Sent:** Friday, May 02, 2014 11:28 AM

**To:** [REDACTED]

Cc: [REDACTED]  
Subject: RE: Brake hose

Thank you!

Thomas Daavettila  
Mobil [REDACTED]

---

From: [REDACTED]  
Sent: Friday, May 02, 2014 10:53 AM  
To: [REDACTED]  
Subject: RE: Brake hose

**Delivered**

Tracking Number: 1Z9V3E750192 [REDACTED]  
Service: UPS Next Day Air®  
Weight: 4.00 lbs  
Shipped/Billed On: 05/01/2014  
Delivered On: 05/02/2014 9:54 A.M.  
Delivered To: D [REDACTED]  
Signed By: HILL  
Left At: Inside Delivery

Greg Hester  
DC Metropolitan Police Department  
Fleet Manager  
[REDACTED]

*"If I had asked people what they wanted, they would have said faster horses." — Henry Ford*

---

From: [REDACTED]  
Sent: Friday, May 02, 2014 10:41 AM  
To: [REDACTED]  
Subject: RE: Brake hose  
Importance: High

Greg- thank you

Thomas- Part are on their way. Tracking info below.

[REDACTED]  
PVT Police Quality Program Management  
Chicago Assembly Plant /Ford Police Programs  
Cell [REDACTED]  
[REDACTED]

---

**From:** [REDACTED]

**Sent:** Friday, May 02, 2014 5:49 AM

**To:** [REDACTED]

**Subject:** RE: Brake hose

**Importance:** High

All-

These 2 vins make 7 units total for the brake hoses-

VIN'S-Date location & miles for brake hoses:

1FM5K8AR7DG [REDACTED] LF brake hose-- miles 34,194 4-23-14

1FM5K8ARXDG [REDACTED] LF brake hose--miles- 45,430 4-28-14

**UPS TRACKING # 1Z9V3E750192655641 OVERNIGHT to this address**

Ford Motor Company  
Attn: Thomas Daavettila  
6200 Mercury Drive  
Dearborn, MI 48126

These- were replaced prior- parts were not called for by Ford warranty to review.  
Due to the date of repair these aren't available.

1FM5K8AR3DG [REDACTED] -- brake hose -- 4-9-14 mi 33,302 (this was not warranty-per Ford, hose was twisted by techs installing brake pads)

1FM5K8AR5DG [REDACTED] --LF brake hose--12-17-13 mi 26,147

1FM5K8AR0DG [REDACTED] --RF Brake hose --12-24-13 mi 16,511

1FM5K8AR1DG [REDACTED] -- RF brake hose --2-24-14- mi- 30,872

1FM5K8AR0DG [REDACTED] --LF brake hose-- 2-25-14 mi 39,369

Greg Hester  
DC Metropolitan Police Department  
Fleet Manager  
202 576 5388 office  
202 497 0397 cell

*"If I had asked people what they wanted, they would have said faster horses." — Henry Ford*

---

**From:** [REDACTED]

**Sent:** Thursday, May 01, 2014 3:55 PM

**To:** [REDACTED]

**Subject:** RE: Brake hose

[REDACTED]

Full VIN Numbers:

1FM5K8AR3DG [REDACTED]  
1FM5K8AR5DG [REDACTED]  
1FM5K8AR0DG [REDACTED]

1FM5K8ARXDG  
1FM5K8AR1DG  
1FM5K8AR0DG

PVT Police Quality Program Management  
Chicago Assembly Plant /Ford Police Programs  
Cell:

---

**From:** [REDACTED].)  
**Sent:** Thursday, May 01, 2014 2:34 PM  
**To:** [REDACTED]  
**Subject:** RE: Brake hose

Would you be able to send me the full VIN numbers for the six vehicles?

Regards,

---

**From:** [REDACTED]  
**Sent:** Wednesday, April 30, 2014 10:43 AM  
**To:** [REDACTED]  
**Subject:** RE: Brake hose

Copy

Greg Hester  
DC Metropolitan Police Department  
Fleet Manager

*"If I had asked people what they wanted, they would have said faster horses." — Henry Ford*

---

**From:** [REDACTED] [com](#)]  
**Sent:** Wednesday, April 30, 2014 10:42 AM  
**To:** [REDACTED]  
**Subject:** RE: Brake hose

Mailing address to send:

Ford Motor Company  
Attn: Thomas Daavettila  
6200 Mercury Drive  
Dearborn, MI 48126

*Tom MacDonald  
Ford Police Programs  
Explorer, Taurus, MKS, MKT  
H-567 Heavy Truck and Transit  
Foundation Brake Engineering*



---

**From:** [REDACTED]

**Sent:** Wednesday, April 30, 2014 10:35 AM

**To:** [REDACTED]

**Subject:** RE: Brake hose

[REDACTED]  
OK, Where do you want the old parts to go ?? Just need the location—so we can send -- Makes no difference to me  
LeeAnn asked for these to be shipped as below—

Hey- maybe I can cut them in half and send each of you a section of the hose –LOL

Mailing address to send:

Ford Motor Company  
Attn: Thomas Daavettila

**From:** [REDACTED] [

**Sent:** Tuesday, April 29, 2014 03:53 PM

**To:** [REDACTED]

**Subject:** FW: Brake hose

Hi [REDACTED]g

Is it possible to ship back any of the brake hoses? Our engineering team in Dearborn would like to evaluate them. I will need each hose identified with VIN.

Mailing address to send:

Ford Motor Company  
Attn: Thomas Daavettila

Thanks

LeeAnn Kirma

Greg Hester  
DC Metropolitan Police Department  
Fleet Manager

*"If I had asked people what they wanted, they would have said faster horses." — Henry Ford*

---

**From:** [REDACTED]  
**Sent:** Wednesday, April 30, 2014 7:21 AM  
**To:** [REDACTED]  
**Subject:** RE: Brake hose

I am in the middle of moving offices so if we can ship to Link Engineering that would be great, if possible can I get the hose overnight shipped please.

Ford Fedex account# 4586-9364-1  
Link Engineering

Attn: Tom MacDonald / Greg Shell

*Tom MacDonald  
Ford Police Programs  
Explorer, Taurus, MKS, MKT  
H-567 Heavy Truck and Transit  
Foundation Brake Engineering*



---

**From:** [REDACTED]  
**Sent:** Wednesday, April 30, 2014 1:16 AM  
**To:** [REDACTED]

Greg,  
Would it be possible to get any of the parts for analysis?

Best Regards,

Randy Freiburger  
Police/Ambulance/QVM, Supervisor  
PDC Bldg. / 1H-J21  
Phone: [REDACTED]

Share the Ford story at [www.TheFordStory.com](http://www.TheFordStory.com)

---

**From:** [REDACTED]  
**Sent:** Tuesday, April 29, 2014 11:13 AM  
**To:** [REDACTED]  
**Subject:** FW: Brake hose  
**Importance:** High

All,  
This is the 6<sup>th</sup> unit with a blown brake hose - vins are below for the others  
1FM5K8ARXDG [REDACTED] with 45,408 miles DC8218 DGA27064 45430 100471 DB5Z2078A LEFT

Here are the VINS and mileages of vehicles with brake hose problems.

TAG	VIN	MILEAGE	RO#	PART #	
DC8230	DG [REDACTED]	26147	96998	DB5Z2078A	LEFT
DC8210	DG [REDACTED]	16511	97137	DB5Z2078B	RIGHT
DC8260	DG [REDACTED]	30872	98684	BB5Z2078B	RIGHT
DC8265	DG [REDACTED]	39369	98738	DB5Z2078A	LEFT
DC8226	DG [REDACTED]	33302	99997	DB5Z2078B	RIGHT
DC8218	DG [REDACTED]	45430	100471	DB5Z2078A	LEFT

Greg Hester  
DC Metropolitan Police Department  
Fleet Manager  
202 576 5388 office  
202 497 0397 cell

*"If I had asked people what they wanted, they would have said faster horses." — Henry Ford*

---

**From:** [REDACTED]  
**Sent:** Tuesday, April 29, 2014 8:59 AM  
**To:** [REDACTED]  
**Subject:** Brake hose

Greg,  
Here are the pictures on the most recent brake hose failure left front utility. We are saving the hose.

Thank You,

Stephen Ferguson  
Operations Manager  
First Vehicle Services  
DC MPD



**April is National Financial Capability Month!**

Evaluate your financial well-being with a [free personal financial health assessment](#) provided by the D.C. Dept. of Insurance, Securities and Banking.

[DISB.DC.gov](http://DISB.DC.gov)



---

**From:** [REDACTED]  
**Sent:** Friday, July 18, 2014 8:43 AM  
**To:** [REDACTED]  
**Subject:** FW: Brake hose- Need Resolution  
**Attachments:** FR 284 Utilities-.xlsx  
  
**Importance:** High

FYI.. This is for the BB53 brake hose.

**From:** [REDACTED]  
**Sent:** Friday, July 18, 2014 8:11 AM  
**To:** [REDACTED]  
**Subject:** RE: Brake hose- Need Resolution

LeeAnn,

Who has looked at this and can you give a status update?

Thanks,

[REDACTED]  
North American Fleet, Lease and Remarketing Operations  
*Fleet Brand Marketing Manager Car/CUV/SUV/Police*  
Office: [REDACTED]

---

**From:** [REDACTED]  
**Sent:** Friday, July 18, 2014 7:43 AM  
**To:** [REDACTED]  
**Subject:** RE: Brake hose- Need Resolution  
**Importance:** High

Folks,

Need this escalated so we can get a resolution- before someone is injured or worse. This is a major safety issue – particularly with this type of vehicle application- No brakes, unable to stop the vehicle is the result after the hose failure--

MPD is continuing to have brake hose failures on the Ford PI Utility units, the 2 part numbers affected are: DB5Z-2078B RF --- DB5Z-2078A LF.

I have looped Ford in on this before, sent hoses to Ford to analyze-

Has there been a reason identified as the failure ?? and I so, what is the plan of action ?

The failures started in Dec 2013, and are continuing to fail, as of yesterday another unit towed in for no brakes- pedal goes to the floor-- I now have 2 vehicles, that both RF and LF hoses that have failed— VINS:

1FM5K8ARXDG [REDACTED] & 1FM5K8AR7D [REDACTED]

What has been the part issue for these hoses-- DB5Z-2078B RF --- DB5Z-2078A LF ??

Info I have found:

- Looking at the vin sequence --- these were all produced under RPN- FR-284, the MSO were all received March 20<sup>th</sup> -27<sup>th</sup>, looks like production was all in March 2012-- vehicles arrived to MPD on April 9<sup>th</sup> - 23<sup>rd</sup>.
- My 2<sup>nd</sup> order of Utilities in 2012, RPN- GP-129 were received in Sept- to date no hose failures on these Utilities/vins

Extremely High Potential for a vendor supply issue for any produce in this time frame—I am attaching all the vins for this RPN-

MPD has been inspecting these hoses at the pm service- yet we continue to have hose failures -

*Before someone is involved in and accident- injury or other-, during a chase or normal operation, I am pulling these into the shop to replace both brake hoses (if hasn't been completed already)*

- **I will be asking Ford for assistance on the replacement of these hoses---**  
What other information do you need from MPD ?

VIN'S-Date location & miles for brake hoses:

- 1FM5K8AR7DG [REDACTED] LF brake hose-- miles 34,194 Date 4-23-14 - TOW IN NO BRAKES / LEAKING -- LF brake hose
- 1FM5K8AR3DG [REDACTED] - brake hose --date 4-9-14 mi 33,302 (this was not warranty-per Ford dealer, hose was twisted)
- 1FM5K8AR5DG [REDACTED] --LF brake hose--date 12-17-13 mi 26,147--Complaint was brakes low -cause was LEFT FRONT BRAKE HOSE LEAKING
- 1FM5K8AR0DG [REDACTED] --RF Brake hose --date -12-24-13 mi 16,511 - Complaint was brakes was fading -- cause send To the dealer for right front brake hose leaking, lower radiator hose leaking. Correction dealer replaced rf hose and lower radiator hose
- 1FM5K8AR1DG [REDACTED] -- RF brake hose --date 2-24-14- mi- 30,872 Complaint : VEHICLE TOWED IN, BRAKES GO TO THE FLOOR Cause: right brake hose leaking
- 1FM5K8AR0DG [REDACTED] --LF brake hose-Date - 2-25-14 mi 39,369 Complaint : tow in in- No start- Cause : found l/f brake hose leaking during safety inspection of the vehicle
- 1FM5K8ARXDG [REDACTED] date 4-28-14, DC8218-DGA27064 Mi 45430 100471 DB5Z2078A LEFT hose , Complaint : BRAKES ARE VERY LOW AND NEED TO BE REPLACED Cause : NEEDS A BRAKE HOSE....WFP. checked for no brake split in brake hose leaking . replaced
- 1FM5K8ARXDG [REDACTED] - Date 5-14-14 miles 46,525 - same vehicle RF hose was replaced- on 5-14-14 Complaint: PM Service due- found bubble in hose during inspection -- Cause PASSDOWN: RIGHT FRONT BRAKE HOSE HAS BUBBLE correction: send to dealer for r/f brake hose / P.T. U NOISE
- 1FM5K8AR6DG [REDACTED] DC87213 7-7-14 miles 39,075- towed in No brakes- rf brake hose leaking- loss of fluid no brakes
- 1FM5K8AR7DG [REDACTED] - Ro102219 Date 7/1/14- found during PM service- LF brake hose leaking, miles 42.802
- 1FM5K8AR7DG [REDACTED] RO# 102595, Date- 7-17-14, miles- 43,891,-- towed in no brakes- pedal goes to the floor RF brake hose blown, leaking fluid
- 1FM5K8AR6DG [REDACTED] RO100829 date 5-9-14 miles 41,504 -- tow in No brakes -- replaced RF hose
- 1FM5K8AR3DG [REDACTED] - date 6-14-14-- LF brake hose-- Dealer replaced Cheaseake Ford replaced towed in no brakes--29,789- towed in miles 29,789

Greg Hester  
DC Metropolitan Police Department  
Fleet Manager



*"If I had asked people what they wanted, they would have said faster horses." — Henry Ford*

---

**From:** [REDACTED] [com]

**Sent:** Thursday, June 05, 2014 10:21 AM

**To:** [REDACTED]

**Cc:** [REDACTED]

**Subject:** RE: Brake hose

Greg – Thank you!

Tom - Please let us know if you need further info

[REDACTED]  
PVT Police Quality Program Management  
Chicago Assembly Plant /Ford Police Programs  
[REDACTED]

---

**From:** [REDACTED] ]

**Sent:** Thursday, June 05, 2014 7:53 AM

**To:** [REDACTED]

**Subject:** RE: Brake hose

Leeann,

Here is what I can pull from the repair orders hope this helps –

We are checking every vehicle now for the brake hose conditions

1FM5K8AR3DG [REDACTED] - brake hose – 4-9-14 mi 33,302 (this was not warranty-per Ford dealer, hose was twisted by techs installing brake pads)

1FM5K8AR5DG [REDACTED] –LF brake hose–12-17-13 mi 26,147– **Complaint was brakes low** -cause was LEFT FRONT BRAKE HOSE LEAKING

1FM5K8AR0DG [REDACTED] –RF Brake hose --12-24-13 mi 16,511 - **Complaint was brakes was fading** –cause send To the dealer for right front brake hose leaking, lower radiator hose leaking. Correction dealer replaced rf hose and lower radiator hose

1FM5K8AR1DG [REDACTED] -- RF brake hose --2-24-14- mi- 30,872 **Complaint : VEHICLE TOWED IN, BRAKES GO TO THE FLOOR** Cause: right brake hose leaking

1FM5K8AR0DG [REDACTED] –LF brake hose-- 2-25-14 mi 39,369 **Complaint : tow in in- No start- Cause : found l/f brake hose leaking during safety inspection of the vehicle**

1FM5K8ARXDG [REDACTED] - DC8218 DGA27064 Mi 45430 100471 DB5Z2078A LEFT hose 4-28-14

**Complaint :** BRAKES ARE VERY LOW AND NEED TO BE REPLACED **Cause :** NEEDS A BRAKE HOSE....WFP. checked for no brake split in brake hose leaking . replaced

1FM5K8ARXDG [REDACTED] - 5-14-14 miles 46,525 - same vehicle

RF hose was replaced- on 5-14-14 Complaint: PM Service due- found bubble in hose during inspection – Cause PASSDOWN: RIGHT FRONT BRAKE HOSE HAS BUBBLE correction: send to dealer for r/f brake hose / P.T. U NOISE

Greg Hester

DC Metropolitan Police Department

Fleet Manager

[REDACTED] cell

*"If I had asked people what they wanted, they would have said faster horses." — Henry Ford*

---

**From:** [REDACTED]

**Sent:** Wednesday, June 04, 2014 10:01 AM

**To:** [REDACTED]

**Subject:** RE: Brake hose

Greg

Thank you for sending in the brake hoses. Our team in Dearborn has been reviewing and evaluating the hoses the last couple of weeks.

Can you provide further information regarding the duty cycle, driving/roads conditions, at failure what was noticed/observed, etc? Any further info will help regarding the analysis.

**LeeAnn Kirma**

PVT Police Quality Program Management

Chicago Assembly Plant /Ford Police Programs

Cell: [REDACTED]

---

**From:** [REDACTED]

**Sent:** Friday, May 02, 2014 11:28 AM

**To:** [REDACTED]

**Subject:** RE: Brake hose

Thank you!

[REDACTED]

---

**From:** [REDACTED]

**Sent:** Friday, May 02, 2014 10:53 AM

**To:** [REDACTED]

**Subject:** RE: Brake hose

**Delivered**

**Tracking Number:** 1Z9V3E750192 [REDACTED]

**Service:** UPS Next Day Air®

**Weight:** 4.00 lbs

**Shipped/Billed On:** 05/01/2014

**Delivered On:** 05/02/2014 9:54 A.M.

**Delivered To:** DEARBORN, MI, US

**Signed By:** HILL

**Left At:** Inside Delivery

Greg Hester

DC Metropolitan Police Department  
Fleet Manager

*"If I had asked people what they wanted, they would have said faster horses." — Henry Ford*

---

**From:** [REDACTED]

**Sent:** Friday, May 02, 2014 10:41 AM

**To:** [REDACTED]

**Subject:** RE: Brake hose

**Importance:** High

Greg- thank you

Thomas- Part are on their way. Tracking info below.

**LeeAnn Kirma**

PVT Police Quality Program Management

Chicago Assembly Plant /Ford Police Programs

Cell: [REDACTED]

---

**From:** [REDACTED]

**Sent:** Friday, May 02, 2014 5:49 AM

**To:** [REDACTED]

**Subject:** RE: Brake hose

**Importance:** High

All-

These 2 vins make 7 units total for the brake hoses-

VIN'S-Date location & miles for brake hoses:

1FM5K8AR7DG [REDACTED] LF brake hose-- miles 34,194 4-23-14

1FM5K8ARXDG [REDACTED] LF brake hose--miles- 45,430 4-28-14

**UPS TRACKING # 1Z9V3E750192655641 OVERNIGHT to this address**

Ford Motor Company  
Attn: Thomas Daavettila  
6200 Mercury Drive  
Dearborn, MI 48126

These- were replaced prior- parts were not called for by Ford warranty to review.

Due to the date of repair these aren't available.

1FM5K8AR3DG [REDACTED] - brake hose – 4-9-14 mi 33,302 (this was not warranty-per Ford, hose was twisted by techs installing brake pads)

1FM5K8AR5DG [REDACTED] —LF brake hose—12-17-13 mi 26,147

1FM5K8AR0DG [REDACTED] —RF Brake hose --12-24-13 mi 16,511

1FM5K8AR1DG [REDACTED] -- RF brake hose --2-24-14- mi- 30,872

1FM5K8AR0DG [REDACTED] —LF brake hose-- 2-25-14 mi 39,369

Greg Hester  
DC Metropolitan Police Department  
Fleet Manager

[REDACTED]  
[REDACTED] cell

*"If I had asked people what they wanted, they would have said faster horses." — Henry Ford*

---

**From:** [REDACTED]  
**Sent:** Thursday, May 01, 2014 3:55 PM  
**To:** [REDACTED]  
**Subject:** RE: Brake hose

Thomas

Full VIN Numbers:

1FM5K8AR3DG [REDACTED]  
1FM5K8AR5DG [REDACTED]  
1FM5K8AR0DG [REDACTED]  
1FM5K8ARXDG [REDACTED]  
1FM5K8AR1DG [REDACTED]  
1FM5K8AR0DG [REDACTED]

**LeeAnn Kirma**  
PVT Police Quality Program Management  
Chicago Assembly Plant /Ford Police Programs  
Cell: [REDACTED]  
[REDACTED]

---

**From:** [REDACTED]  
**Sent:** Thursday, May 01, 2014 2:34 PM  
**To:** [REDACTED]  
**Subject:** RE: Brake hose

Greg,

Would you be able to send me the full VIN numbers for the six vehicles?

Regards,  
[REDACTED]  
Mobil: [REDACTED]

---

**From:** [REDACTED]

**Sent:** Wednesday, April 30, 2014 10:43 AM

**To:** [REDACTED]

**Subject:** RE: Brake hose

Copy

Greg Hester  
DC Metropolitan Police Department  
Fleet Manager  
202 576 5388 office  
202 497 0397 cell

*"If I had asked people what they wanted, they would have said faster horses." — Henry Ford*

---

**From:** [REDACTED]

**Sent:** Wednesday, April 30, 2014 10:42 AM

**To:** [REDACTED]

**Subject:** RE: Brake hose

Mailing address to send:  
Ford Motor Company  
Attn: Thomas Daavettila

[REDACTED]

*Tom MacDonald  
Ford Police Programs  
Explorer, Taurus, MKS, MKT  
H-567 Heavy Truck and Transit  
Foundation Brake Engineering*

[REDACTED]



---

**From:** [REDACTED]

**Sent:** Wednesday, April 30, 2014 10:35 AM

**To:** [REDACTED]

**Subject:** RE: Brake hose

Tom,

OK, Where do you want the old parts to go ?? Just need the location—so we can send -- Makes no difference to me  
LeeAnn asked for these to be shipped as below—

Hey- maybe I can cut them in half and send each of you a section of the hose –LOL

Mailing address to send:

**Ford Motor Company**

**Attn: Thomas Daavettila**

[REDACTED]

**From:** [REDACTED]

**Sent:** Tuesday, April 29, 2014 03:53 PM

**To:** [REDACTED]

[REDACTED]

**Subject:** FW: Brake hose

Hi Greg

Is it possible to ship back any of the brake hoses? Our engineering team in Dearborn would like to evaluate them. I will need each hose identified with VIN.

Mailing address to send:

Ford Motor Company

Attn: Thomas Daavettila

[REDACTED]

Thanks

**LeeAnn Kirma**

**Greg Hester**

**DC Metropolitan Police Department**

**Fleet Manager**

[REDACTED] cell

*"If I had asked people what they wanted, they would have said faster horses." — Henry Ford*

---

**From:** [REDACTED]

**Sent:** Wednesday, April 30, 2014 7:21 AM

**To:** [REDACTED]

**Subject:** RE: Brake hose

I am in the middle of moving offices so if we can ship to Link Engineering that would be great, if possible can I get the hose overnight shipped please.



Ford Fedex account# 4586-9364-1  
Link Engineering



Attn: Tom MacDonald / Greg Shell

*Tom MacDonald  
Ford Police Programs  
Explorer, Taurus, MKS, MKT  
H-567 Heavy Truck and Transit  
Foundation Brake Engineering  
313-805-4765*



---

**From:** [REDACTED]  
**Sent:** Wednesday, April 30, 2014 1:16 AM  
**To:** [REDACTED]  
**Subject:** RE: Brake hose

Greg,  
Would it be possible to get any of the parts for analysis?

Best Regards,

Randy Freiburger  
Police/Ambulance/QVM, Supervisor  
PDC Bldg. / 1H-J21  
Phone: [REDACTED]  
[REDACTED]

---

**From:** [REDACTED]  
**Sent:** Tuesday, April 29, 2014 11:13 AM  
**To:** [REDACTED]  
**Subject:** FW: Brake hose  
**Importance:** High

All,  
This is the 6<sup>th</sup> unit with a blown brake hose - vins are below for the others  
1FM5K8ARXDG [REDACTED] with 45,408 miles DC8218 DGA27064 45430 100471 DB5Z2078A LEFT

Here are the VINS and mileages of vehicles with brake hose problems.

TAG	VIN	MILEAGE	RO#	PART #
-----	-----	---------	-----	--------

DC8230	DGAA27053	26147	96998	DB5Z2078A	LEFT
DC8210	DGA27056	16511	97137	DB5Z2078B	RIGHT
DC8260	DGA31570	30872	98684	BB5Z2078B	RIGHT
DC8265	DGA31575	39369	98738	DB5Z2078A	LEFT
DC8226	DGA27049	33302	99997	DB5Z2078B	RIGHT
DC8218	DGA27064	45430	100471	DB5Z2078A	LEFT

Greg Hester  
DC Metropolitan Police Department  
Fleet Manager

[REDACTED]  
cell

*"If I had asked people what they wanted, they would have said faster horses." — Henry Ford*

---

**From:** [REDACTED]  
**Sent:** Tuesday, April 29, 2014 8:59 AM  
**To:** [REDACTED]  
**Subject:** Brake hose

Greg,  
Here are the pictures on the most recent brake hose failure left front utility. We are saving the hose.

Thank You,  
Stephen Ferguson  
Operations Manager  
First Vehicle Services  
DC MPD

[REDACTED]

**April is National Financial Capability Month!**

Evaluate your financial well-being with a [free personal financial health assessment](#) provided by the D.C. Dept. of Insurance, Securities and Banking.  
[DISB.DC.gov](http://DISB.DC.gov)

RPN #	Type	VIN #	MSO Rcvd	Vehicle Rcvd	Invoice	Date	
FR284	Utility	1FM5K8AR7DG	21-Mar	12-Apr	E0412305	04/17/12	1
FR284	Utility	1FM5K8AR9DG	20-Mar	13-Apr	E0412305	04/17/12	2
FR284	Utility	1FM5K8AR0DG	20-Mar	13-Apr	E0412305	04/17/12	3
FR284	Utility	1FM5K8AR2DG	20-Mar	9-Apr	E0412305	04/17/12	4
FR284	Utility	1FM5K8AR4DG	20-Mar	9-Apr	E0412305	04/17/12	5
FR284	Utility	1FM5K8AR6DG	20-Mar	13-Apr	E0412305	04/17/12	6
FR284	Utility	1FM5K8AR2DG	20-Mar	13-Apr	E0412305	04/17/12	7
FR284	Utility	1FM5K8AR4DG	20-Mar	13-Apr	E0412305	04/17/12	8
FR284	Utility	1FM5K8AR6DG	20-Mar	9-Apr	E0412305	04/17/12	9
FR284	Utility	1FM5K8AR8DG	20-Mar	17-Apr	E0412305	04/17/12	10
FR284	Utility	1FM5K8ARxDG	20-Mar	17-Apr	E0412305	04/17/12	11
FR284	Utility	1FM5K8AR1DG	20-Mar	9-Apr	E0412305	04/17/12	12
FR284	Utility	1FM5K8AR4DG	21-Mar	17-Apr	E0417740	4/25/2012	13
FR284	Utility	1FM5K8AR1DG	21-Mar	17-Apr	E0417740	4/25/2012	14
FR284	Utility	1FM5K8AR3DG	21-Mar	23-Apr	E0417741	4/25/2012	15
FR284	Utility	1FM5K8ARxDG	21-Mar	12-Apr	E0417742	4/25/2012	16
FR284	Utility	1FM5K8AR1DG	21-Mar	25-May	E0417743	4/25/2012	17
FR284	Utility	1FM5K8AR3DG	21-Mar	13-Apr	E0417744	4/25/2012	18
FR284	Utility	1FM5K8AR5DG	21-Mar	12-Apr	E0417745	4/25/2012	19
FR284	Utility	1FM5K8AR3DG	20-Mar	9-Apr	E0417746	4/25/2012	20
FR284	Utility	1FM5K8AR5DG	20-Mar	9-Apr	E0417747	4/25/2012	21
FR284	Utility	1FM5K8AR7DG	20-Mar	13-Apr	E0417748	4/25/2012	22
FR284	Utility	1FM5K8AR9DG	20-Mar		E0417749	4/25/2012	23
FR284	Utility	1FM5K8AR1DG	26-Mar	17-Apr	E0417750	4/25/2012	24
FR284	Utility	1FM5K8AR3DG	26-Mar	17-Apr	E0417751	4/25/2012	25
FR284	Utility	1FM5K8AR5DG	26-Mar	17-Apr	E0417752	4/25/2012	26
FR284	Utility	1FM5K8AR7DG	26-Mar	17-Apr	E0417753	4/25/2012	27
FR284	Utility	1FM5K8AR9DG	26-Mar	17-Apr	E0417754	4/25/2012	28
FR284	Utility	1FM5K8AR0DG	26-Mar	17-Apr	E0417755	4/25/2012	29
FR284	Utility	1FM5K8AR2DG	27-Mar	23-Apr	E0417756	4/25/2012	30
FR284	Utility	1FM5K8AR9DG	27-Mar	23-Apr	E0417757	4/25/2012	31
FR284	Utility	1FM5K8AR0DG	27-Mar	23-Apr	E0417758	4/25/2012	32
FR284	Utility	1FM5K8AR2DG	27-Mar	20-Apr	E0417759	4/25/2012	33
FR284	Utility	1FM5K8AR4DG	27-Mar	20-Apr	E0417760	4/25/2012	34
FR284	Utility	1FM5K8AR6DG	27-Mar	20-Apr	E0417761	4/25/2012	35
FR284	Utility	1FM5K8AR8DG	27-Mar	25-Apr	E0417762	4/25/2012	36
FR284	Utility	1FM5K8ARxDG	27-Mar	25-Apr	E0417763	4/25/2012	37
FR284	Utility	1FM5K8AR1DG	27-Mar	25-Apr	E0417764	4/25/2012	38
FR284	Utility	1FM5K8AR3DG	27-Mar	3-May	E0417765	4/25/2012	39
FR284	Utility	1FM5K8AR5DG	27-Mar	17-Apr	E0417766	4/25/2012	40
FR284	Utility	1FM5K8AR1DG	27-Mar	17-Apr	E0417767	4/25/2012	41
FR284	Utility	1FM5K8AR3DG	27-Mar	25-Apr	E0417768	4/25/2012	42
FR284	Utility	1FM5K8AR5DG	27-Mar	3-May	E0417769	4/25/2012	43
FR284	Utility	1FM5K8AR7DG	27-Mar	17-Apr	E0417770	4/25/2012	44
FR284	Utility	1FM5K8AR9DG	27-Mar	17-Apr	E0417771	4/25/2012	45

FR284	Utility	1FM5K8AR1DG		27-Mar	17-Apr	E0417772	4/25/2012	46
-------	---------	-------------	--	--------	--------	----------	-----------	----

---

**From:** [REDACTED] (J.)  
**Sent:** Friday, May 02, 2014 7:09 AM  
**To:** [REDACTED] (M.)  
**Subject:** FW: Brake hose  
  
**Importance:** High

FYI.

*Tom MacDonald  
Ford Police Programs  
Explorer, Taurus, MKS, MKT  
H-567 Heavy Truck and Transit  
Foundation Brake Engineering*



---

**From:** [REDACTED]  
**Sent:** Friday, May 02, 2014 6:49 AM  
**To:** [REDACTED]  
**Subject:** RE: Brake hose  
**Importance:** High

All-

These 2 vins make 7 units total for the brake hoses-

VIN'S-Date location & miles for brake hoses:

1FM5K8AR7DG [REDACTED] LF brake hose-- miles 34,194 4-23-14

1FM5K8ARXDG [REDACTED] LF brake hose--miles- 45,430 4-28-14

**UPS TRACKING # 1Z9V3E750192655641 OVERNIGHT to this address**

Ford Motor Company

Attn: Thomas Daavettila

[REDACTED]  
These- were replaced prior- parts were not called for by Ford warranty to review.  
Due to the date of repair these aren't available.

1FM5K8AR3DG [REDACTED] -- brake hose - 4-9-14 mi 33,302 (this was not warranty-per Ford, hose was twisted by techs installing brake pads)

1FM5K8AR5DG [REDACTED] --LF brake hose--12-17-13 mi 26,147

1FM5K8AR0DG [REDACTED] --RF Brake hose --12-24-13 mi 16,511

1FM5K8AR1DG [REDACTED] -- RF brake hose --2-24-14- mi- 30,872

1FM5K8AR0DG [REDACTED] --LF brake hose-- 2-25-14 mi 39,369

Greg Hester  
DC Metropolitan Police Department  
Fleet Manager

[Redacted] cell

*"If I had asked people what they wanted, they would have said faster horses." — Henry Ford*

---

**From:** [Redacted]  
**Sent:** Thursday, May 01, 2014 3:55 PM  
**To:** [Redacted]  
**Subject:** RE: Brake hose

Thomas

Full VIN Numbers:

- 1FM5K8AR3DG [Redacted]
- 1FM5K8AR5DG [Redacted]
- 1FM5K8AR0DG [Redacted]
- 1FM5K8ARXDG [Redacted]
- 1FM5K8AR1DG [Redacted]
- 1FM5K8AR0DG [Redacted]

**LeeAnn Kirma**  
PVT Police Quality Program Management  
Chicago Assembly Plant /Ford Police Programs  
Cell: [Redacted]  
[Redacted]

---

**From:** [Redacted]  
**Sent:** Thursday, May 01, 2014 2:34 PM  
**To:** [Redacted] .)  
**Subject:** RE: Brake hose

Greg,  
  
Would you be able to send me the full VIN numbers for the six vehicles?

Regards,  
[Redacted]

---

**From:** [Redacted]  
**Sent:** Wednesday, April 30, 2014 10:43 AM  
**To:** [Redacted]  
(T.W.)  
**Subject:** RE: Brake hose

Copy

Greg Hester  
DC Metropolitan Police Department  
Fleet Manager

cell

*"If I had asked people what they wanted, they would have said faster horses." — Henry Ford*

---

**From:** [REDACTED]

**Sent:** Wednesday, April 30, 2014 10:42 AM

**To:** [REDACTED]

**Subject:** RE: Brake hose

Mailing address to send:

**Ford Motor Company**  
**Attn: Thomas Daavettila**

*Tom MacDonald*  
*Ford Police Programs*  
*Explorer, Taurus, MKS, MKT*  
*H-567 Heavy Truck and Transit*  
*Foundation Brake Engineering*



---

**From:** [REDACTED]

**Sent:** Wednesday, April 30, 2014 10:35 AM

**To:** [REDACTED]

**Subject:** RE: Brake hose

[REDACTED],  
OK, Where do you want the old parts to go ?? Just need the location—so we can send -- Makes no difference to me  
LeeAnn asked for these to be shipped as below—

Hey- maybe I can cut them in half and send each of you a section of the hose –LOL

Mailing address to send:

**Ford Motor Company**  
**Attn: Thomas Daavettila**

[REDACTED]

**From:** [REDACTED] [  
**Sent:** Tuesday, April 29, 2014 03:53 PM  
**To:** [REDACTED]  
**Cc:** [REDACTED]

**Subject:** FW: Brake hose

Hi Greg

Is it possible to ship back any of the brake hoses? Our engineering team in Dearborn would like to evaluate them. I will need each hose identified with VIN.

Mailing address to send:

Ford Motor Company  
Attn: Thomas Daavettila

[REDACTED]

Thanks

**LeeAnn Kirma**

**Greg Hester**  
**DC Metropolitan Police Department**  
**Fleet Manager**

[REDACTED]

*"If I had asked people what they wanted, they would have said faster horses." — Henry Ford*

---

**From:** [REDACTED]  
**Sent:** Wednesday, April 30, 2014 7:21 AM  
**To:** [REDACTED]  
**Subject:** RE: Brake hose

I am in the middle of moving offices so if we can ship to Link Engineering that would be great, if possible can I get the hose overnight shipped please.

Ford Fedex account# [REDACTED]  
Link Engineering

[REDACTED]



Attn: Tom MacDonald / Greg Shell

*Tom MacDonald  
Ford Police Programs  
Explorer, Taurus, MKS, MKT  
H-567 Heavy Truck and Transit  
Foundation Brake Engineering*

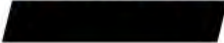

---

**From:** [Redacted]  
**Sent:** Wednesday, April 30, 2014 1:16 AM  
**To:** [Redacted]  
**Subject:** RE: Brake hose

[Redacted],  
Would it be possible to get any of the parts for analysis?

Best Regards,

Randy Freiburger  
Police/Ambulance/QVM, Supervisor  
PDC Bldg. / 1H-J21  
Phone: [Redacted]

---

**From:** [Redacted]  
**Sent:** Tuesday, April 29, 2014 11:13 AM  
**To:** [Redacted]  
**Subject:** FW: Brake hose  
**Importance:** High

All,  
This is the 6<sup>th</sup> unit with a blown brake hose - vins are below for the others  
1FM5K8ARXDG [Redacted] with 45,408 miles DC8218 DGA27064 45430 100471 DB5Z2078A LEFT

Here are the VINS and mileages of vehicles with brake hose problems.

TAG	VIN	MILEAGE	RO#	PART #	
DC8230	DG [Redacted]	26147	96998	DB5Z2078A	LEFT
DC8210	DG [Redacted]	16511	97137	DB5Z2078B	RIGHT
DC8260	DG [Redacted]	30872	98684	BB5Z2078B	RIGHT
DC8265	DG [Redacted]	39369	98738	DB5Z2078A	LEFT
DC8226	DG [Redacted]	33302	99997	DB5Z2078B	RIGHT
DC8218	DG [Redacted]	45430	100471	DB5Z2078A	LEFT

Greg Hester  
DC Metropolitan Police Department  
Fleet Manager

[REDACTED]  
cell

*"If I had asked people what they wanted, they would have said faster horses." — Henry Ford*

---

**From:** Ferguson, Stephen (MPD)  
**Sent:** Tuesday, April 29, 2014 8:59 AM  
**To:** [REDACTED]  
**Subject:** Brake hose

Greg,  
Here are the pictures on the most recent brake hose failure left front utility. We are saving the hose.

Thank You,  
Stephen Ferguson  
Operations Manager  
First Vehicle Services  
DC MPD

[REDACTED]

**April is National Financial Capability Month!**

Evaluate your financial well-being with a [free personal financial health assessment](#) provided by the D.C. Dept. of Insurance, Securities and Banking.

[DISB.DC.gov](http://DISB.DC.gov)

---

**From:** [REDACTED] J.)  
**Sent:** Friday, July 25, 2014 10:22 AM  
**To:** [REDACTED] )  
**Subject:** FW: Explorer PI brake hose  
**Attachments:** ODI\_2013 Explorer PI\_hose sample.jpg; ODI\_hose sample\_4.jpg

Pete, for your information.

*Eric Britton*  
Government Investigations  
Tel. [REDACTED]  
[REDACTED]

---

**From:** [REDACTED]  
**Sent:** Friday, July 25, 2014 10:14 AM  
**To:** [REDACTED]  
**Subject:** FW: Explorer PI brake hose

Eric, photos of the Explorer jounce hose as discussed.

Please forward to Pete Williams, and then please help facilitate his review next week at the DC fleet with Chris Lash from ODI.

Thanks,  
[REDACTED]

---

**From:** [REDACTED]  
**Sent:** Friday, July 25, 2014 9:35 AM  
**To:** [REDACTED]  
**Subject:** FW: Explorer PI brake hose

[REDACTED]  
Chief, Vehicle Control Division  
National Highway Traffic Safety Administration  
Office of Defects Investigation  
NVS-213 Room W48-312  
[REDACTED]  
[REDACTED]

---

IMPORTANT WARNING: This email (and any attachments) is only intended for the use of the person or entity to which it is addressed, and may contain information that is privileged and confidential. You, the recipient, are obligated to maintain it in a safe, secure and confidential manner. Unauthorized redisclosure or failure to maintain confidentiality

may subject you to federal and state penalties. If you are not the recipient, please immediately notify us by return email, and delete this message from your computer.

-----

---

**From:** [REDACTED]  
**Sent:** Thursday, July 24, 2014 11:56 AM  
**To:** [REDACTED]  
**Subject:** Explorer PI brake hose

Its small, down in between 2 ribs and oddly diagonal across the groove. Even knowing generally were it was it was hard to find. This is magnified 50x.

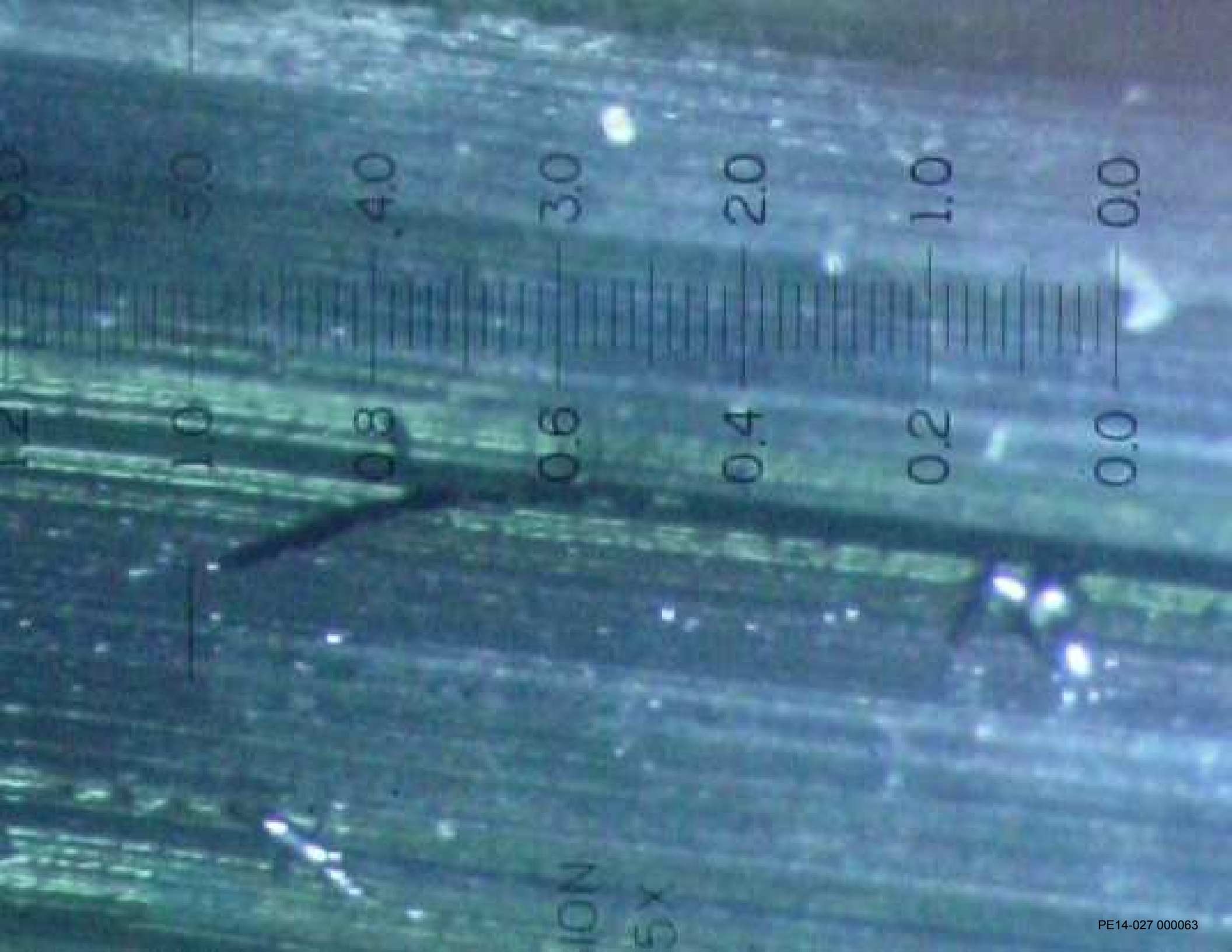

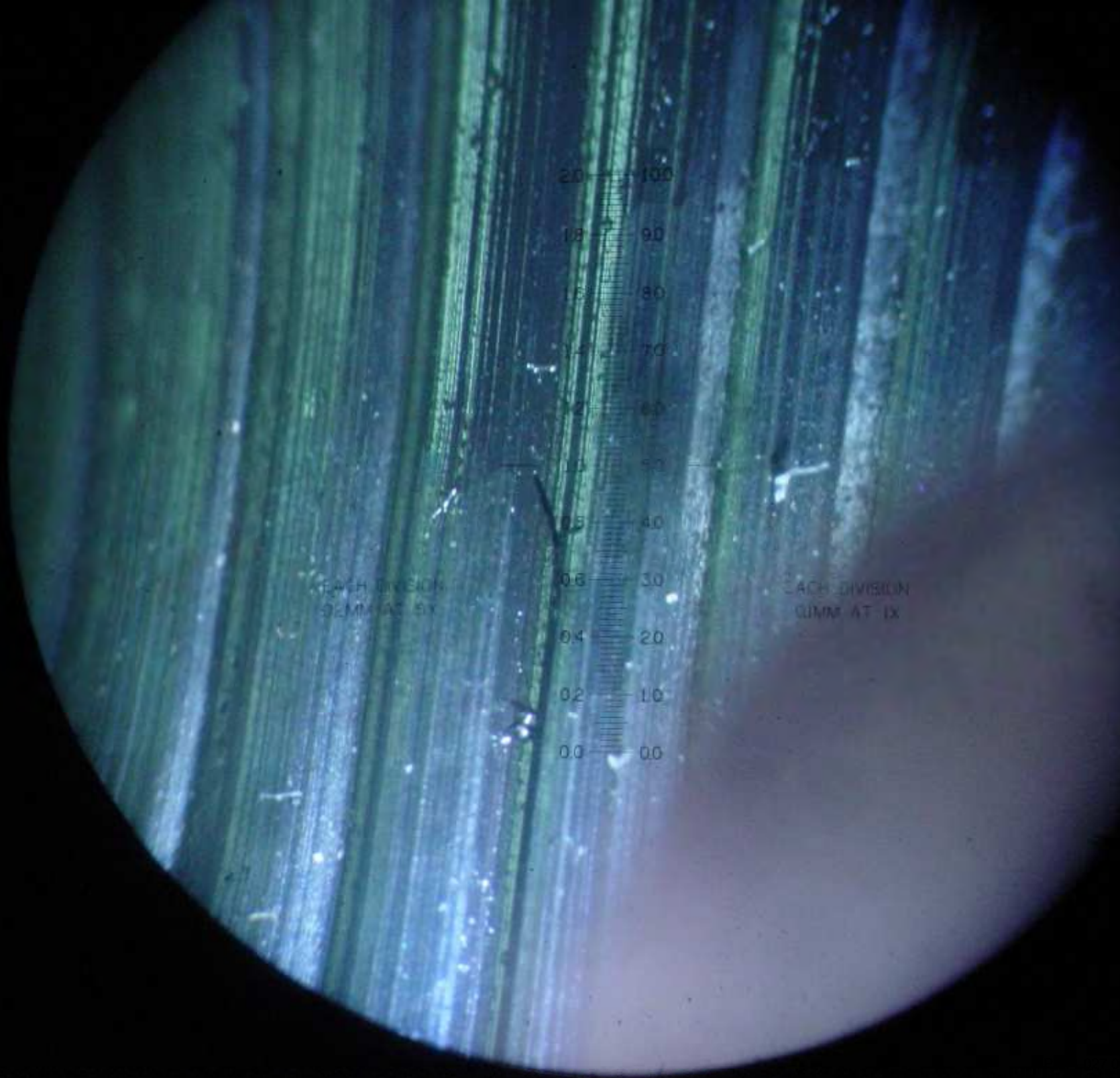

EACH DIVISION  
0.2MM AT 5X

EACH DIVISION  
0.1MM AT 1X

2.0 100  
1.8 90  
1.6 80  
1.4 70  
1.2 60  
1.0 50  
0.8 40  
0.6 30  
0.4 20  
0.2 10  
0.0 00

---

**From:** [REDACTED]  
**Sent:** Monday, August 04, 2014 8:08 AM  
**To:** [REDACTED]  
**Cc:** [REDACTED]  
**Subject:** FW: Explorer Police steering question

**Importance:** High

Pete the 2014 & 2015 Police and base vehicle gears have the same rack travel. The sport model has a restricted travel because of the larger wheels.

[REDACTED] *Supervisor*  
*Office/Cell Phone:* [REDACTED]

---

**From:** [REDACTED] J.)  
**Sent:** Monday, August 04, 2014 7:50 AM  
**To:** [REDACTED]  
**Subject:** RE: Explorer Police steering question  
**Importance:** High

Steve, please check into and respond.  
Thanks.

[REDACTED]  
Manager, Chassis – EPAS and Upper Steering, Features, Systems & Core  
Fairlane North, Building 3, GT-004  
cell [REDACTED]  
[REDACTED]

---

**From:** [REDACTED]  
**Sent:** Monday, August 04, 2014 7:17 AM  
**To:** [REDACTED]  
**Subject:** Explorer Police steering question

[REDACTED]

Do the Explorer Police vehicles have a different steering rack travel than a retail Explorer?

Thank You

Pete Williams  
Brake Supervisor, V363, B299, D258, D385, D47X, U502, Econoline, C489  
FN3 – HS015  
313-805-4797





---

**From:** [REDACTED] s  
**Sent:** Tuesday, August 19, 2014 7:42 PM  
**To:** Vandeyar, Christine (C.A.)  
**Cc:** [REDACTED] )  
**Subject:** Fw: Returned parts from DC police

Please see below:

Sincerely,

[REDACTED]

Hitachi Cable America, Inc.  
[REDACTED]

Cell: [REDACTED]  
[REDACTED]

— Forwarded by Tom-HCIDET Castaldi/hapdet on 08/19/2014 07:41 PM —

**From:** [REDACTED]  
**Date:** 08/19/2014 04:12 PM  
**Subject:** RE: Returned parts from DC police

Tom,

I analyzed all the parts and only found 1 vehicle that had the DB53. Only one the right side. All others were the BB53's.

22 DB53-2078-AB 1FM5K8AR3DG [REDACTED] 39463  
BB53-2B557-AD 1FM5K8AR3DG [REDACTED] 39463

Thanks,

CC

**From:** [REDACTED]  
[REDACTED]  
**Subject:** Fw: Returned parts from DC police

Can you guys review the hoses to see if they returned any of the DB53 parts.

Sincerely,

Tom Castaldi

[REDACTED]

[REDACTED]

----- Forwarded by Tom-HCIDET Castaldi/hapdet on 08/19/2014 03:07 PM -----

From: [REDACTED]  
Date: 08/19/2014 02:55 PM  
Subject: Returned parts from DC police

---

[REDACTED]

Can you work with Tom Castaldi and identify any hoses that may have been returned that were the current design hose? Possibly the garage could have replaced parts a second time if an issue was only on one side.

Thank You

Pete Williams  
Brake Supervisor, V363, B299, D258, D385, D47X, U502, Econoline, C489  
FN3 – HS015  
313-805-4797

---

**From:** [REDACTED] (D.)  
**Sent:** Wednesday, August 27, 2014 10:47 AM  
**To:** [REDACTED]  
**Subject:** FW: 2011-2014 Explorer Brake Jounce Hose

FYI; I failed to CC you guys on this not

I advised Pete to use the VINs in the data file to access the info he is seeking thru AWS

---

**From:** [REDACTED]  
**Sent:** Wednesday, August 27, 2014 10:23 AM  
**To:** [REDACTED]  
**Subject:** RE: 2011-2014 Explorer Brake Jounce Hose

The file I sent has the VINs so you can access the data thru AWS for the actual claims info.

[REDACTED]

---

**From:** [REDACTED]  
**Sent:** Wednesday, August 27, 2014 9:47 AM  
**To:** [REDACTED]  
**Subject:** RE: 2011-2014 Explorer Brake Jounce Hose

Can I get the actual claims that were used to create this document?

Thank You

[REDACTED]  
Brake Supervisor, V363, B299, D258, D385, D47X, U502, Econoline, C489  
FN3 – HS015  
313-805-4797

---

**From:** [REDACTED]  
**Sent:** Tuesday, August 05, 2014 10:44 AM  
**To:** [REDACTED]  
**Subject:** 2011-2014 Explorer Brake Jounce Hose

Attached to this file is an update/revised version of the 2011-2014 Explorer Brake Jounce Hose excel file I was using this morning. Please discard previously received versions.

<< File: 2011 thru 2014 Explorer Alleged Leak at Jounce Hose Comm Symp search from CDR on 07232014.xlsx >>

Steve Matthews  
Product Concern Analyst  
Automotive Safety Office  
[REDACTED]

---

**From:** [REDACTED]  
**Sent:** Friday, January 20, 2012 3:07 PM  
**To:** [REDACTED]  
**Subject:** FW: AIMS #3220464 - Jounce hose

Wendy, please input words into AIMS per below to close this issue. Thanks.

---

**From:** [REDACTED]  
**Sent:** Friday, January 20, 2012 1:27 PM  
**To:** [REDACTED]  
**Subject:** RE: AIMS #3220464 - Jounce hose

OK

[REDACTED]  
Manager, Brake Applications Engineering  
[REDACTED]

---

**From:** [REDACTED]  
**Sent:** Friday, January 20, 2012 1:20 PM  
**To:** [REDACTED]  
**Subject:** FW: AIMS #3220464 - Jounce hose  
**Importance:** High

Dave, we just confirmed through a complete jounce test that the current hose meets all of our specifications but is right at the spec limit for one condition. As a robustness action we will tighten the tolerance on the hose length to include only the upper-end of the spec (nominal to max).

[REDACTED]  
Brake System Supervisor  
D-Car / U502 / V363N / VN127 Platforms  
Chassis Engineering  
(313) 805-0431

---

**From:** [REDACTED]  
**Sent:** Wednesday, January 18, 2012 9:45 AM  
**To:** [REDACTED]  
**Subject:** Issue #3220464 - Added to Team

\*\*\*\*\* PLEASE DO NOT REPLY TO THIS MESSAGE  
\*\*\*\*\* This message was generated by the Ford AIM system.

You have been added to the team for Issue # [3220464](#) in the Ford AIM system.

Issue #: [3220464](#)

Issue Title: FNA Durability - 2013 PP DGA00047 - Front brake hoses in tension at rebound - Incident 695520

LVMY: U502-2013

Risk: (not yet specified)

Added by: Cavin Daniel (CDANIEL7)

The Ford AIM system can be accessed at 

Generated from AIM

Generated by CDANIEL7 on 18-JAN-2012

Ford Confidential

Printed Copies are Uncontrolled

---

**From:** [REDACTED]  
**Sent:** Thursday, April 12, 2012 2:37 PM  
**To:** [REDACTED]  
**Subject:** FW: Brake Hoses

[Pictures of the ZF tool.](#)

---

**From:** [REDACTED]  
**Sent:** Tuesday, April 03, 2012 11:33 AM  
**To:** [REDACTED]  
**Subject:** FW: Brake Hoses

Brad  
See Sergio's explanation below.

[REDACTED]  
Senior Manufacturing Engineer  
ZF Lemforder  
Chicago IL  
[REDACTED]

---

**From:** [REDACTED]  
**Sent:** Tuesday, April 03, 2012 11:06 AM  
**To:** [REDACTED]  
**Subject:** RE: Brake Hoses

[REDACTED],  
The picture below describes my issue. The top portion of the pictures shows the current production brake hose. The lower portion shows the bottom portion of the new brake hose.

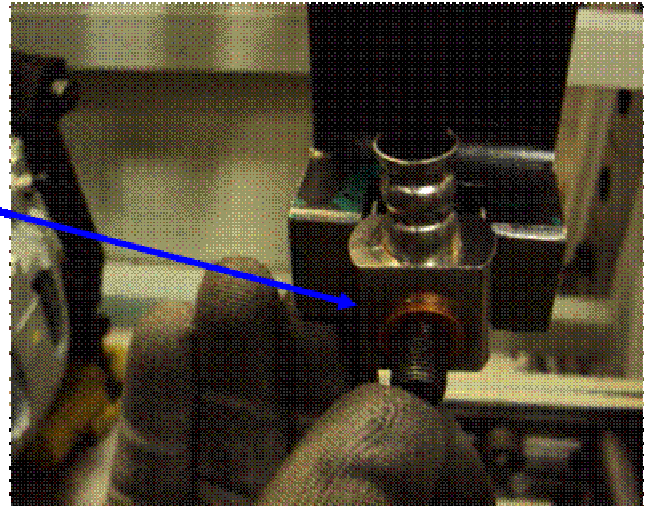
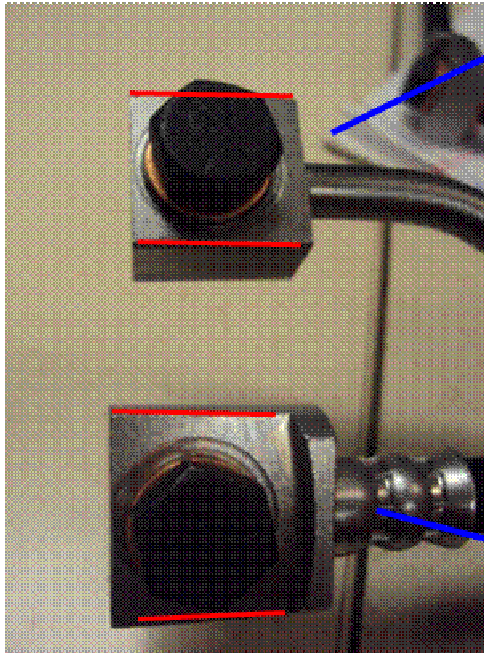
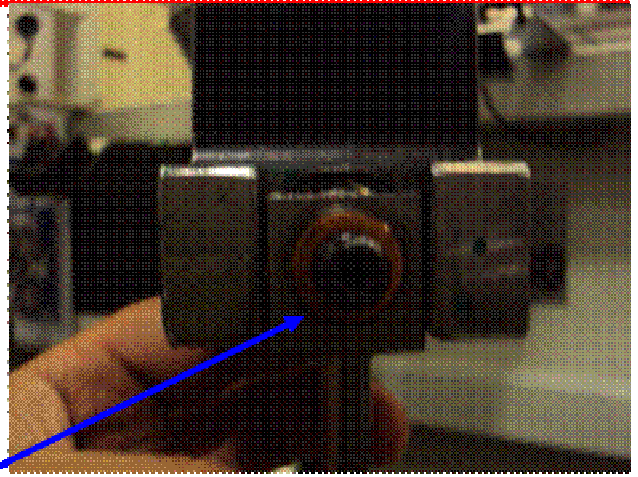

**Block is wider on new U502 part. Is this change permanent for the U? Are we also doing this for the D? If we use both the thinner block and the wider block, we would almost certainly need two torque guns at this station**



---

**From:** [REDACTED]

**Sent:** Tuesday, April 03, 2012 9:54 AM

**To:** [REDACTED]

**Subject:** Brake Hoses

[REDACTED],

Attached are the hose drawings for the ole & new versions. Per my earlier voicemail I checked the dimensions of the brackets and they all appear to be the same so what was the issue with the brackets not fitting the poke yoke check fixture?

Regards,

[REDACTED]

**Senior Engineer**  
**ZF Lemforder Chassis Systems**

[REDACTED]

---

**From:** [REDACTED]  
**Sent:** Thursday, January 12, 2012 4:09 PM  
**To:** [REDACTED]  
**Subject:** FW: DURIS DEFECT Incident - EXPLORER DGA00047 (S2CG\_1): Frt brake hose (#695520)  
**Attachments:** DGA00047\_FrtBrakeLine\_01-12-12.wmv; DGA00047\_001.jpg; DGA00047\_002.jpg

---

**From:** [REDACTED].)  
**Sent:** Thursday, January 12, 2012 4:07 PM  
**To:** [REDACTED]  
**Subject:** DURIS DEFECT Incident - EXPLORER DGA00047 (S2CG\_1): Frt brake hose (#695520)

DURIS Incident 695520 is available via the link below:

CPSC: 06.08.02

Program and Sub Program: U502 - 2013 U502 POLICE INTERCEPTOR LQOS DURABILITY

Originator: GINFANTE Date Issued: 12-JAN-2012 04:05:53

Security Classification: Confidential Record Type: Transient/Unofficial

The data in these reports should be treated as confidential and protected accordingly. This is a transient/unofficial record when extracted to Excel or Printed.

[REDACTED] [0](#)

[REDACTED] [REDACTED]

*MPG Chassis System Engineering*

[REDACTED]



**DGA000**

PE14-027 000077



**DGA000**

PE14-027-000078

---

**From:** [REDACTED]  
**Sent:** Monday, February 13, 2012 9:39 AM  
**To:** [REDACTED]  
**Subject:** FW: FW: U502 Proposed Banjo Block Thickness Change for Big/Small Brake

We have an issue on threaded inlet for further bolt engagement due to thinner MCR banjo block.

Can't perform TTS/TTF study with the parts I provided.

Requesting cost/timing from Akebono to increase thread engagement. As well as prototype parts for sealing study.

[REDACTED]

---

**From:** [REDACTED]  
**Sent:** Friday, February 10, 2012 2:42 PM  
**To:** [REDACTED]  
**Subject:** RE: FW: U502 Proposed Banjo Block Thickness Change for Big/Small Brake

[REDACTED]  
I was given wrong information from the plant. The inlet on both big & small brake are not threaded the full length. We will need to change the depth of the thread to accommodate the proposed banjo block.  
ABG is working up numbers for the increase in cycle time as this is one of the bottle-neck operations.

Don't quote me on this, but I can't imagine that it would be enough of an increase to warrant a cost increase. We would also need to make new gages (about \$xxxx, again not a firm number)  
ABG is working up a cost estimate.

have a nice weekend

[REDACTED]

---

**From:** [REDACTED]  
**Date:** 02/10/2012 12:51 PM  
**Subject:** RE: FW: U502 Proposed Banjo Block Thickness Change for Big/Small Brake

---

Brian, you gave me feed back on big brake threaded through hole, is it the same on small brake? Will thinner block work with carryover bolt?

[REDACTED]

**From:** [REDACTED]  
**Sent:** Thursday, February 02, 2012 12:52 PM  
**To:** [REDACTED]  
**Subject:** RE: FW: U502 Proposed Banjo Block Thickness Change for Big/Small Brake

Brian, I'll punt to Wendy to answer your questions.

[REDACTED]

---

**From:** [REDACTED]  
**Sent:** Thursday, February 02, 2012 12:51 PM  
**To:** [REDACTED]  
**Subject:** Re: FW: U502 Proposed Banjo Block Thickness Change for Big/Small Brake

[REDACTED]

Need to confirm a couple of things

1. Flow bolt length. From Bottom to head to the end of the bolt. Best information I have (from a recent Mustang stack-up) is 28.2 - 28.7
2. Is it the Ford requirement that there needs to be enough thread length in the caliper to accommodate the length of the flow bolt is assembled without the two copper washers.  
(This is what was assumed recently for Mustang caliper)

thanks

[REDACTED] \*\*\*\*\* Please consider the environment before printing this message! This e-mail message and any attachments may contain legally privileged, confidential or proprietary information, or information otherwise protected by law, of Akebono Brake Corporation, its affiliates or third parties. This notice serves as marking of its "Confidential" status as defined in any confidentiality agreements concerning the sender and recipient. If you are not the intended recipient(s), or the employee or agent responsible for delivery of this message to the intended recipient(s), you are hereby notified that any dissemination, distribution or copying of this e-mail message is strictly prohibited. If you have received this message in error, please immediately notify the sender and delete this e-mail message from your computer.

\*\*\*\*\* Please consider the environment before printing this message! This e-mail message and any attachments may contain legally privileged, confidential or proprietary information, or information otherwise protected by law, of Akebono Brake Corporation, its affiliates or third parties. This notice serves as marking of its "Confidential" status as defined in any confidentiality agreements concerning the sender and recipient. If you are not the intended recipient(s), or the employee or agent responsible for delivery of this message to the intended recipient(s), you are hereby notified that any dissemination, distribution or copying of this e-mail message is strictly prohibited. If you have received this message in error, please immediately notify the sender and delete this e-mail message from your computer.

---

**From:** [REDACTED]  
**Sent:** Friday, May 02, 2014 11:28 AM  
**To:** [REDACTED]  
**Subject:** Hose  
**Attachments:** 0502141126a.jpg

Sent from my Verizon Wireless 4G LTE Smartphone.





---

**From:** [REDACTED]  
**Sent:** Monday, January 16, 2012 6:12 PM  
**To:** [REDACTED]  
**Subject:** Hoses to Caliper  
**Attachments:** U502 MCR.jpg; U502 Current.jpg; Dcar.jpg

Thank You,

[REDACTED]

Hitachi Cable Florida

[REDACTED]

Phone: [REDACTED]

[REDACTED]



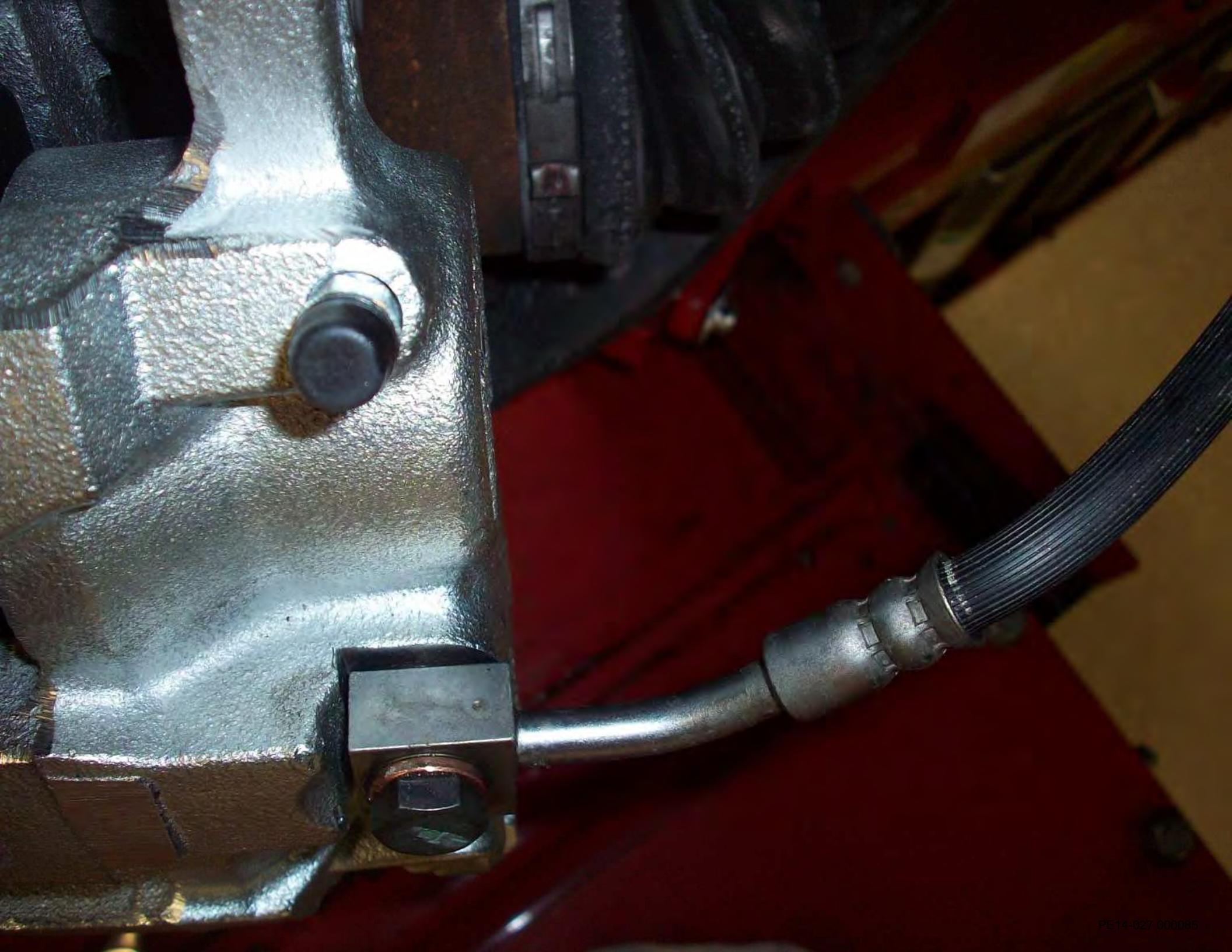

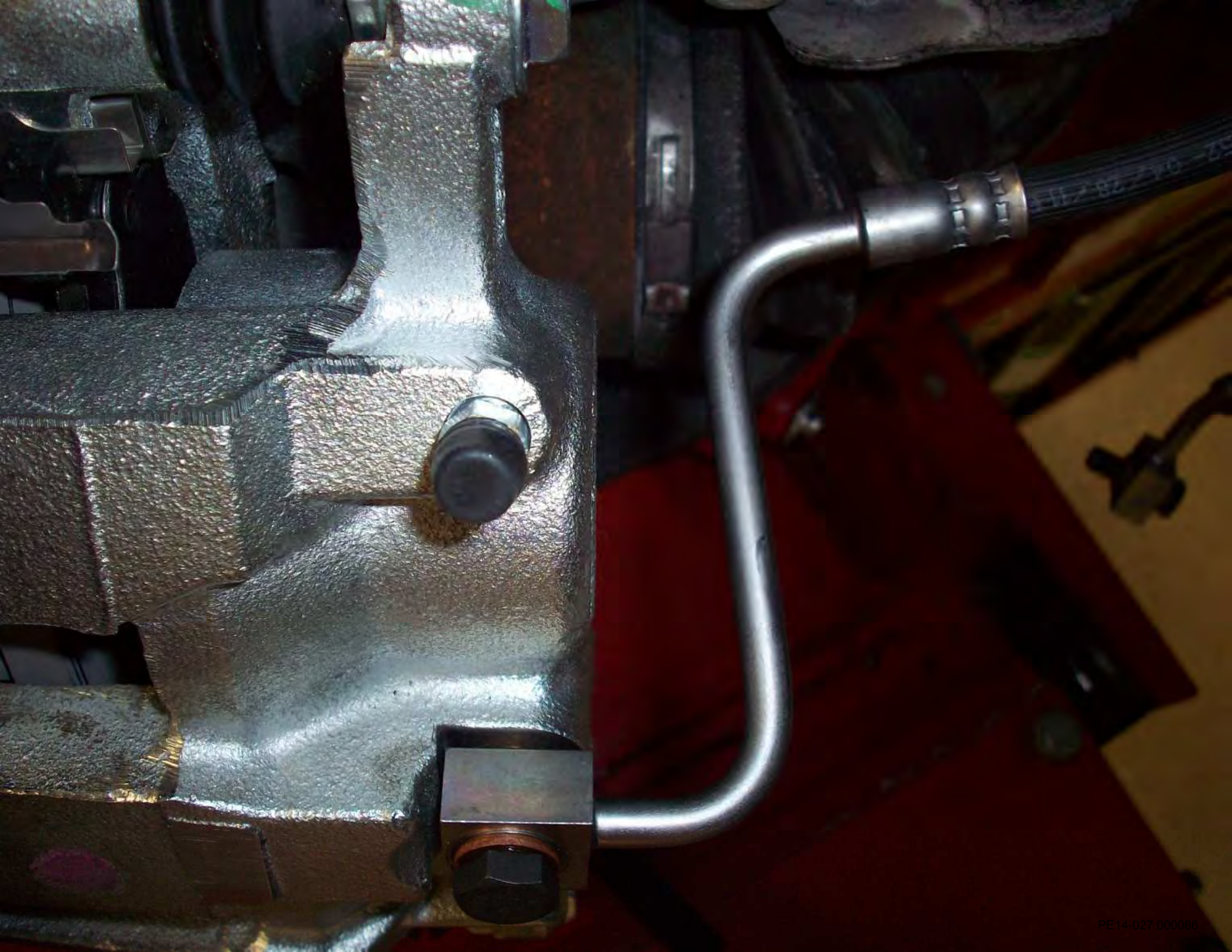

6 vehicles 3L/3R

2 parts back - both failed outside crimp still

\* Pete Williams visited the fleet

Chris Lush  
Jeff Grant

DC police fleet April 2012 has issues  
vehicles w/ later prod date have no

BB level part 1.0 mil cycle test  
DB 1.3 mil cycles test

\* Same hose used on police & non police application

\* NHTSA had visited the fleet some time as Ford engineer

\* New level hose has eliminated the short  
braided end of the caliper end

\* Failure appears to occur at the body  
side / end of the hose; not the  
caliper end of the hose

\* No loss of brakes, tell-tale light comes on

BB53 2018  
DB53 revised hose

---

**From:** [REDACTED]  
**Sent:** Friday, August 22, 2014 5:17 PM  
**To:** [REDACTED]  
**Subject:** Opening Ford PE Resume #PE14-027: Front Brake Line Leaks on 2013 Explorer Police Interceptor Vehicles  
**Attachments:** INOA-PE14027-5708.pdf

Please find an advanced copy of NHTSA's new PE investigation #PE14-027 into 2013 MY Explorer police interceptor vehicles. The Agency opened this PE based on a communication with a D.C. police fleet that reported replacing 13 front brake jounce lines due to leaks. It is scheduled to be posted to the NHTSA website on Monday, August 25.

NOTE: GASC Internal Investigations became aware of this issue a day or two before the Agency originally contacted us. Since that time, Ford ASO and Engineering have had technical discussions with the Agency and our supplier, and participated in a joint inspection of the D.C. fleet. It is unclear when Ford will receive an information request, but our internal investigation, part analysis, and work with Engineering and our brake line supplier is ongoing.

Best Regards,

*Todd Fronckowiak*

Assistant Director  
Global Automotive Safety and Compliance  
Automotive Safety Office  
Ford Motor Company  
Phone: [REDACTED]

---

**From:** [REDACTED]  
**Sent:** Friday, August 22, 2014 4:46 PM  
**To:** [REDACTED]  
**Subject:** Opening Resume #PE14-027

Attached please find an advanced copy of the Opening Resume for investigation #PE14-027. The investigation was opened on August 22, 2014 with the following subject: Front Brake Hose Failure, and involving the following makes and models: 2013 Ford Explorer Police Interceptor. This is an uncertified copy, and it is not to be distributed publicly. Please be advised that there may be revisions or edits made to this resume between today's date and the publication date of the certified version on NHTSA's public website.

ODI requests that you embargo this document until the certified copy, available for public distribution, appears on NHTSA's public website, [REDACTED], on August 25, 2014.

Thank you,

[REDACTED]  
Administrative Staff Assistant, Office of Defects Investigation  
National Highway Traffic Safety Administration (NHTSA)

---

**From:** [REDACTED]  
**Sent:** Tuesday, August 05, 2014 1:38 PM  
**To:** [REDACTED]  
**Subject:** Police Explorer jounce hose

Outcome of the CCRG meeting is that I need to go back in 3 weeks. I had 3 follow up items that were requested.

- 1) MKT hose same as Explorer?
- 2) Any prior brake repairs done on the police units?
- 3) Rubber analysis done at central labs?

Thank You

Pete Williams  
Brake Supervisor, V363, B299, D258, D385, D47X, U502, Econoline, C489  
FN3 – HS015  
313-805-4797

# Police Fleet VINS

VIN	Description of leak or source/cause	Total
1FM5K8AR0DG	jounce hose stretch	1
1FM5K8AR0DG	at jounce hose - 2 lines (1 AWS, 16 GPs) 16511/33302	1
1FM5K8AR1DG	at jounce hose - 2 lines (1 AWS, 16 GPs) 30883/30787	1
1FM5K8AR0DG	at jounce hose - NO AWS, LOGS DOWN	1
1FM5K8ARXDG	hose split ← NO AWS 2 GPs	1
1FM5K8AR6DG	at jounce hose ← NO AWS	1
1FM5K8AR7DG	at jounce hose ← NO AWS	1
1FM5K8AR7DG	at jounce hose ← NO AWS	1
1FM5K8AR6DG	at jounce hose - NO AWS	1
1FM5K8AR5DG	at jounce hose - 2 lines (1 AWS, 16 GPs)	1
1FM5K8ARXDG	bulge in hose ←	1
		11
		11
		11

NO AWS CLAIM



EGREMOD5  
EGREMOD11

> SAME VIN

1FM5K8ARXDG

SAME REPORT DATE

- 2 Diff mileage

45430 005 ✓ 46525 011

- One had "hose split in it" 005  
other "bubble in hose" 011

EGREMOD7 SAME VIN  
EGREMOD8

1FM5K8AR7DG

- 2 Diff mileage  
42802 (007)  
16511 (008)

- One report LF (007)  
other RF (008)

74 reports  
64 unique VINS



Sort Field One 1

Count of ECI	Record ID	Model Year	Source Code	Dealer Name	Source Claim Key
		2013	GCQIS Ford	FORD MOTOR CO. FPSDGO FLT SVC	EFQCB003
					EGREM002
					EGREM003
					EGREM004
					EGREM005
					EGREM006
					EGREM007
					EGREM008
					EGREM009
					EGREM010
					EGREM011
				FORD MOTOR CO. FPSDGO FLT SVC Total	
			<b>GCQIS Ford Total</b>		
<hr/>					
		<b>2013 Total</b>			
<hr/>					
		<b>Grand Total</b>			

EFQCB003

- ✓ hose split
- ✓ joune hose stretch
- ✓ @ benjo bolt
- ✓ bulge in hose
- ✓ at joune hose fitting
- ✓ at joune hose

---

**From:** [REDACTED]  
**Sent:** Wednesday, August 27, 2014 11:30 AM  
**To:** [REDACTED]  
**Subject:** RE: Big Brakes  
**Attachments:** Re: U502 hose date

Hitachi started shipping new U502 hoses to the plant on 6/19/2012. There were no D-car hose changes around that time.

---

**From:** [REDACTED]  
**Sent:** Wednesday, August 27, 2014 8:49 AM  
**To:** [REDACTED]  
**Subject:** FW: Big Brakes

Below are the dates that big brake launched. Now need to determine when the MCR hose came into production at the plant.

Wendy, I am not sure if you were the tube and hose D&R at that time.

Thank You

[REDACTED]  
Brake Supervisor, V363, B299, D258, D385, D47X, U502, Econoline, C489  
FN3 – HS015  
313-805-4797

---

**From:** [REDACTED].)  
**Sent:** Tuesday, August 26, 2014 6:17 PM  
**To:** [REDACTED]  
**Subject:** RE: Big Brakes

Job2 do you mean 2012 and not 2014

[REDACTED]  
PVT Police Quality Program Management  
Ford Motor Company  
Chicago Assembly Plant  
Cell [REDACTED]  
[REDACTED]

---

**From:** [REDACTED]  
**Sent:** Tuesday, August 26, 2014 4:06 PM  
**To:** [REDACTED]  
**Subject:** RE: Big Brakes

LeeAnn,

2013 Job 1 = 2/6/2012

2013 Job 2 = 9/3/2014

Hope this helps!

[REDACTED]  
PPM Material Planning & Logistics  
U502 Explorer Program Timer  
[REDACTED]

---

**From:** [REDACTED]  
**Sent:** Tuesday, August 26, 2014 4:39 PM  
**To:** [REDACTED]  
**Subject:** Big Brakes

[REDACTED]  
Can you confirm actual dates?

Heavy Duty Brakes – Police at 2013MY J1

Heavy Duty Brakes – Retail at 2013MY J2 (Base (with 18" tires), XLT, LTD, Sport)

[REDACTED]  
PVT Police Quality Program Management  
Ford Motor Company  
Chicago Assembly Plant  
Cell: [REDACTED]  
[REDACTED]

---

**From:** [REDACTED]  
**Sent:** Wednesday, August 06, 2014 7:57 AM  
**To:** [REDACTED]  
**Cc:** [REDACTED]  
**Subject:** RE: Brake hose- Need Resolution

FYI Tracking numbers – package was shipped Aug 5<sup>th</sup>  
Master track # 805915895941 , package # 803336345265 & 803336345276  
[https://www.fedex.com/fedextrack/html/index.html?tracknumbers=805915895941&cntry\\_code=us&r=g&cntry\\_code=us](https://www.fedex.com/fedextrack/html/index.html?tracknumbers=805915895941&cntry_code=us&r=g&cntry_code=us)

<https://www.fedex.com/fedextrack/html/index.html?tracknu...>

[MPDC Inside](#)
[Registratio...](#)

[My Profile](#)

**FedEx**
[Ship](#)
[Track](#)
[Manage](#)
[Learn](#)
[FedEx Office](#)

## FedEx® Tracking

★
✎
803336345276

Ship (P/U) date :  
**Tues 8/05/2014 4:22 pm**

WAS US

In transit

WASHINGTON, DC

📦 3 Piece shipment

Tracking Number or Nick...	Shipper city, st...	Ship (P/U) date	Status
805915895941(master)	WAS, DC	8/05/2014	
803336345265	WAS, DC	8/05/2014	
803336345276	WAS, DC	8/05/2014	

[Hold at FedEx Location](#)
[Request Notifications](#)
[Obtain Proof of Delivery](#)

Let us tell you when your shipment arrives. Sign up for delivery notifica

### Travel History

▲Date/Time	Activity
- 8/05/2014 - Tuesday	
9:26 pm	Left FedEx origin facility
4:22 pm	Picked up

**Greg Hester**  
 DC Metropolitan Police Department  
 Fleet Manager  
[REDACTED] cell

*"If I had asked people what they wanted, they would have said faster horses." — Henry Ford*

---

**From:** [REDACTED]  
**Sent:** Friday, August 01, 2014 9:56 AM  
**To:** [REDACTED]  
**Subject:** RE: Brake hose- Need Resolution

Greg,

Please ship the parts using the address and FedEx account below:

FedEx Account: 458902860

[REDACTED]

Thank You,

[REDACTED]

---

**From:** [REDACTED]  
**Sent:** Friday, August 01, 2014 9:27 AM  
**To:** [REDACTED]  
**Subject:** RE: Brake hose- Need Resolution

Yes, I have one of my Engineers working on getting you a Fed Ex account number and the ship to location.

Tom, please get this done today.

[REDACTED]  
Brake Supervisor, V363, B299, D258, D385, D47X, U502, Econoline, C489  
FN3 – HS015  
[REDACTED] 7

---

**From:** [REDACTED]  
**Sent:** Friday, August 01, 2014 9:26 AM  
**To:** [REDACTED].)  
**Subject:** RE: Brake hose- Need Resolution  
**Importance:** High

[REDACTED]  
Does Ford want the hoses shipped ?? and if so, can you provide a ship to location.

Greg Hester  
DC Metropolitan Police Department  
Fleet Manager

[REDACTED] cell

*"If I had asked people what they wanted, they would have said faster horses." — Henry Ford*

---

**From:** [REDACTED]  
**Sent:** Friday, July 25, 2014 1:58 PM  
**To:** [REDACTED]  
**Subject:** RE: Brake hose- Need Resolution

[REDACTED]

What time Wednesday morning works best for you for me to be there?

Thank You

[REDACTED]  
Brake Supervisor, V363, B299, D258, D385, D47X, U502, Econoline, C489  
FN3 – HS015  
313-805-4797

---

**From:** [REDACTED]  
**Sent:** Wednesday, July 23, 2014 9:34 AM  
**To:** [REDACTED]  
**Subject:** Re: Brake hose- Need Resolution

Thanks

---

**From:** [REDACTED]  
**Sent:** Wednesday, July 23, 2014 09:30 AM  
**To:** [REDACTED]  
**Subject:** RE: Brake hose- Need Resolution

No you don't need to update the A-B parts. As long as the part prefix is the DB5Z those are the latest released parts and the parts you want to use.

[REDACTED]  
Brake Supervisor, V363, B299, D258, D385, D47X, U502, Econoline, C489  
FN3 – HS015  
313-805-4797

DC Public Schools' Beautification Day is on Saturday, August 23! Roll up your sleeves and help beautify our schools. [Sign up](#) to volunteer.

---

**From:** [REDACTED]  
**Sent:** Wednesday, July 23, 2014 8:27 AM  
**To:** [REDACTED]  
**Subject:** RE: Brake hose- Need Resolution  
**Importance:** High

All,  
The replacement hose's came t the dealer mixed--the part numbers have changed – these are now D/Dog- C/Charlie parts numbers -  
Should we be replacing all A-B hoses with D-C hose numbers???

**Left side hose - DB5Z-2078 A is now D**  
**Right side hose -DB5Z-2078 B is now C**

**Greg Hester**  
**DC Metropolitan Police Department**  
**Fleet Manager**

[REDACTED]  
cell

*"If I had asked people what they wanted, they would have said faster horses." — Henry Ford*

---

**From:** [REDACTED]  
**Sent:** Tuesday, July 22, 2014 1:58 PM  
**To:** [REDACTED]  
**Subject:** RE: Brake hose- Need Resolution

Greg,  
Can you get me address of your location? I need to make travel plans, current plan is to be there morning of July 29<sup>th</sup> and return August 1<sup>st</sup>.

Thank You

[REDACTED]  
Brake Supervisor, V363, B299, D258, D385, D47X, U502, Econoline, C489  
FN3 – HS015  
[REDACTED]

---

**From:** [REDACTED ]  
**Sent:** Tuesday, July 22, 2014 10:37 AM  
**To:** [REDACTED]  
**Subject:** RE: Brake hose- Need Resolution

Sure can

- What part number was used when the hoses were replaced? **DB5Z-2078B RF --- DB5Z-2078A LF**
- Have there been any repeat failures once the hoses were replaced- **So far. No replacements have failed —as of this date**
- Are any of the parts still available to send to us, again we were able to get only 2 hoses.—**Yes I have 1 hose now, I have ordered new hoses for all the units (45) in this vin sequence, that have not been changed- I can't take the chance- Those will be replaced, starting tomorrow, so I will have plenty of hoses shortly. .**
- Is it possible to send people out and what dates would you be able to support a visit? **Yes anytime is fine –**

I have attached a vin list of the units we have had the brake hose failures— all have failed in approx. the same location- RS or LS

The 2<sup>nd</sup> order of Utilities we received in Sept of 2012- to date **Have NOT** had any hose failures --



Greg Hester  
DC Metropolitan Police Department  
Fleet Manager

cell

*"If I had asked people what they wanted, they would have said faster horses." — Henry Ford*

---

**From:** [REDACTED]  
**Sent:** Tuesday, July 22, 2014 10:07 AM  
**To:** [REDACTED]  
**Subject:** RE: Brake hose- Need Resolution

Greg,

Can you provide some additional info. We have the 2 parts that have been returned and can set up a meeting to review the current status, I would even like to come out and review the vehicles in DC to better understand any unique duty cycles, environments, etc. that could help us in this investigation. If you could provide some feed back to the below questions it would be helpful.

- What part number was used when the hoses were replaced?
- Have there been any repeat failures once the hoses were replaced.
- Are any of the parts still available to send to us, again we were able to get only 2 hoses.
- Is it possible to send people out and what dates would you be able to support a visit?

Thank You

[REDACTED]  
Brake Supervisor, V363, B299, D258, D385, D47X, U502, Econoline, C489  
FN3 – HS015  
313-805-4797

---

**From:** [REDACTED]  
**Sent:** Friday, July 18, 2014 7:55 AM  
**To:** [REDACTED].)  
**Subject:** FW: Brake hose- Need Resolution  
**Importance:** High

Steve,

What are you seeing on your end regarding this?

---

**From:** [REDACTED]  
**Sent:** Friday, July 18, 2014 7:43 AM  
**To:** [REDACTED]  
**Subject:** RE: Brake hose- Need Resolution  
**Importance:** High

Folks,

Need this escalated so we can get a resolution- before someone is injured or worse. This is a major safety issue – particularly with this type of vehicle application- No brakes, unable to stop the vehicle is the result after the hose failure--

MPD is continuing to have brake hose failures on the Ford PI Utility units, the 2 part numbers affected are: DB5Z-2078B RF --- DB5Z-2078A LF.

I have looped Ford in on this before, sent hoses to Ford to analyze-

**Has there been a reason identified as the failure ?? and I so, what is the plan of action ?**

The failures started in Dec 2013, and are continuing to fail, as of yesterday another unit towed in for no brakes- pedal goes to the floor-- I now have 2 vehicles, that both RF and LF hoses that have failed— VINS:

1FM5K8ARXDG [REDACTED] & 1FM5K8AR7DG [REDACTED]

**What has been the part issue for these hoses-- DB5Z-2078B RF --- DB5Z-2078A LF ??**

Info I have found:

- Looking at the vin sequence --- these were all produced under RPN- FR-284, the MSO were all received March 20<sup>th</sup> -27<sup>th</sup>, looks like production was all in March 2012-- vehicles arrived to MPD on April 9<sup>th</sup> – 23<sup>rd</sup> .
- My 2<sup>nd</sup> order of Utilities in 2012, RPN- GP-129 were received in Sept- to date no hose failures on these Utilities/vins

Extremely High Potential for a vendor supply issue for any produce in this time frame—I am attaching all the vins for this RPN-

MPD has been inspecting these hoses at the pm service- yet we continue to have hose failures -

*Before someone is involved in and accident- injury or other-, during a chase or normal operation, I am pulling these into the shop to replace both brake hoses (if hasn't been completed already)*

- **I will be asking Ford for assistance on the replacement of these hoses---**

**What other information do you need from MPD ?**

**VIN'S-Date location & miles for brake hoses:**

- 1FM5K8AR7DG [REDACTED] LF brake hose-- miles 34,194 Date 4-23-14 - TOW IN NO BRAKES / LEAKING – LF brake hose
- 1FM5K8AR3DG [REDACTED] -- brake hose –date 4-9-14 mi 33,302 (this was not warranty-per Ford dealer, hose was twisted)
- 1FM5K8AR5DG [REDACTED] —LF brake hose—date 12-17-13 mi 26,147—Complaint was brakes low -cause was LEFT FRONT BRAKE HOSE LEAKING
- 1FM5K8AR0DG [REDACTED] —RF Brake hose —date -12-24-13 mi 16,511 - Complaint was brakes was fading – cause send To the dealer for right front brake hose leaking, lower radiator hose leaking. Correction dealer replaced rf hose and lower radiator hose
- 1FM5K8AR1DG [REDACTED] - RF brake hose –date 2-24-14- mi- 30,872 Complaint : VEHICLE TOWED IN, BRAKES GO TO THE FLOOR Cause: right brake hose leaking
- 1FM5K8AR0DG [REDACTED] —LF brake hose-Date - 2-25-14 mi 39,369 Complaint : tow in in- No start- Cause : found l/f brake hose leaking during safety inspection of the vehicle
- 1FM5K8ARXDG [REDACTED] date 4-28-14, DC8218-DGA27064 Mi 45430 100471 DB5Z2078A LEFT hose , Complaint : BRAKES ARE VERY LOW AND NEED TO BE REPLACED Cause : NEEDS A BRAKE HOSE....WFP. checked for no brake split in brake hose leaking . replaced
- 1FM5K8ARXDG [REDACTED] - Date 5-14-14 miles 46,525 - same vehicle RF hose was replaced- on 5-14-14 Complaint: PM Service due- found bubble in hose during inspection – Cause PASSDOWN: RIGHT FRONT BRAKE HOSE HAS BUBBLE correction: send to dealer for r/f brake hose / P.T. U NOISE
- 1FM5K8AR6DG [REDACTED] - DC87213 7-7-14 miles 39,075- towed in No brakes- rf brake hose leaking- loss of fluid no brakes
- 1FM5K8AR7DG [REDACTED] - Ro102219 Date 7/1/14- found during PM service- LF brake hose leaking, miles 42.802
- 1FM5K8AR7DG [REDACTED] RO# 102595, Date- 7-17-14, miles- 43,891,— towed in no brakes- pedal goes to the floor RF brake hose blown, leaking fluid
- 1FM5K8AR6DG [REDACTED] RO100829 date 5-9-14 miles 41,504 -- tow in No brakes -- replaced RF hose

· 1FM5K8AR3DG [REDACTED] - date 6-14-14-- LF brake hose-- Dealer replaced Cheaseake Ford replaced towed in no brakes--29,789- towed in miles 29,789

Greg Hester  
DC Metropolitan Police Department  
Fleet Manager

[REDACTED] cell

*"If I had asked people what they wanted, they would have said faster horses." — Henry Ford*

---

**From:** [REDACTED]  
**Sent:** Thursday, June 05, 2014 10:21 AM  
**To:** [REDACTED]  
**Subject:** RE: Brake hose

Greg – Thank you!

Tom - Please let us know if you need further info

### LeeAnn Kirma

PVT Police Quality Program Management  
Chicago Assembly Plant /Ford Police Programs  
Cell: [REDACTED]

---

**From:** [REDACTED]  
**Sent:** Thursday, June 05, 2014 7:53 AM  
**To:** [REDACTED]  
**Subject:** RE: Brake hose

Leeann,

Here is what I can pull from the repair orders hope this helps –

We are checking every vehicle now for the brake hose conditions

1FM5K8AR3DG [REDACTED] - brake hose – 4-9-14 mi 33,302 (this was not warranty-per Ford dealer, hose was twisted by techs installing brake pads)

1FM5K8AR5DG [REDACTED] —LF brake hose—12-17-13 mi 26,147— **Complaint was brakes low** -cause was LEFT FRONT BRAKE HOSE LEAKING

1FM5K8AR0DG [REDACTED] —RF Brake hose --12-24-13 mi 16,511 - **Complaint was brakes was fading** —cause send To the dealer for right front brake hose leaking, lower radiator hose leaking. Correction dealer replaced rf hose and lower radiator hose

1FM5K8AR1DG [REDACTED] - RF brake hose --2-24-14- mi- 30,872 **Complaint : VEHICLE TOWED IN, BRAKES GO TO THE FLOOR** Cause: right brake hose leaking

1FM5K8AR0DG [REDACTED] —LF brake hose-- 2-25-14 mi 39,369 **Complaint : tow in in- No start- Cause : found l/f brake hose leaking during safety inspection of the vehicle**

1FM5K8ARXDG [REDACTED] - DC8218 DGA27064 Mi 45430 100471 DB5Z2078A LEFT hose 4-28-14

**Complaint : BRAKES ARE VERY LOW AND NEED TO BE REPLACED Cause : NEEDS A BRAKE HOSE....WFP. checked for no brake split in brake hose leaking . replaced**

1FM5K8ARXDG [REDACTED] - 5-14-14 miles 46,525 - same vehicle

RF hose was replaced- on 5-14-14 Complaint: PM Service due- found bubble in hose during inspection – Cause PASSDOWN: RIGHT FRONT BRAKE HOSE HAS BUBBLE correction: send to dealer for r/f brake hose / P.T. U NOISE

Greg Hester  
DC Metropolitan Police Department  
Fleet Manager

[REDACTED]  
[REDACTED] cell

*"If I had asked people what they wanted, they would have said faster horses." — Henry Ford*

---

**From:** [REDACTED]

**Sent:** Wednesday, June 04, 2014 10:01 AM

**To:** [REDACTED]

**Subject:** RE: Brake hose

Greg

Thank you for sending in the brake hoses. Our team in Dearborn has been reviewing and evaluating the hoses the last couple of weeks.

Can you provide further information regarding the duty cycle, driving/roads conditions, at failure what was noticed/observed, etc? Any further info will help regarding the analysis.

**LeeAnn Kirma**

PVT Police Quality Program Management  
Chicago Assembly Plant /Ford Police Programs

Cell: [REDACTED]  
Email: [REDACTED]

---

**From:** [REDACTED]

**Sent:** Friday, May 02, 2014 11:28 AM

**To:** [REDACTED]

**Subject:** RE: Brake hose

Thank you!

Thomas Daavettila  
Mobil [REDACTED]

---

**From:** [REDACTED]

**Sent:** Friday, May 02, 2014 10:53 AM

**To:** [REDACTED]

**Subject:** RE: Brake hose

**Delivered**

Tracking Number: 1Z9V3E750192655641  
Service: UPS Next Day Air®  
Weight: 4.00 lbs  
Shipped/Billed On: 05/01/2014  
**Delivered On: 05/02/2014 9:54 A.M.**  
Delivered To: DEARBORN, MI, US  
Signed By: HILL  
Left At: Inside Delivery

Greg Hester  
DC Metropolitan Police Department  
Fleet Manager

[REDACTED]  
[REDACTED] cell

*"If I had asked people what they wanted, they would have said faster horses." — Henry Ford*

---

**From:** [REDACTED]  
**Sent:** Friday, May 02, 2014 10:41 AM  
**To:** [REDACTED]  
**Subject:** RE: Brake hose  
**Importance:** High

Greg- thank you

Thomas- Part are on their way. Tracking info below.

**LeeAnn Kirma**

PVT Police Quality Program Management  
Chicago Assembly Plant /Ford Police Programs  
Cell [REDACTED]  
[REDACTED]

---

**From:** [REDACTED]  
**Sent:** Friday, May 02, 2014 5:49 AM  
**To:** [REDACTED]  
**Subject:** RE: Brake hose  
**Importance:** High

All-  
These 2 vins make 7 units total for the brake hoses-  
VIN'S-Date location & miles for brake hoses:  
1FM5K8AR7DG [REDACTED] LF brake hose-- miles 34,194 4-23-14  
1FM5K8ARXDG [REDACTED] LF brake hose--miles- 45,430 4-28-14

**UPS TRACKING # 1Z9V3E750192655641 OVERNIGHT to this address**

Ford Motor Company  
Attn: Thomas Daavettila  
6200 Mercury Drive  
Dearborn, MI 48126

These- were replaced prior- parts were not called for by Ford warranty to review.  
Due to the date of repair these aren't available.

1FM5K8AR3DG [REDACTED] -- brake hose -- 4-9-14 mi 33,302 (this was not warranty-per Ford, hose was twisted by techs installing brake pads)  
1FM5K8AR5DG [REDACTED] --LF brake hose--12-17-13 mi 26,147  
1FM5K8AR0DG [REDACTED] --RF Brake hose --12-24-13 mi 16,511  
1FM5K8AR1DG [REDACTED] -- RF brake hose --2-24-14- mi- 30,872  
1FM5K8AR0DG [REDACTED] --LF brake hose-- 2-25-14 mi 39,369

Greg Hester  
DC Metropolitan Police Department  
Fleet Manager

[REDACTED]  
[REDACTED] cell

*"If I had asked people what they wanted, they would have said faster horses." — Henry Ford*

---

**From:** [REDACTED]  
**Sent:** Thursday, May 01, 2014 3:55 PM  
**To:** [REDACTED]  
**Subject:** RE: Brake hose

Thomas

Full VIN Numbers:

1FM5K8AR3DG [REDACTED]  
1FM5K8AR5DG [REDACTED]  
1FM5K8AR0DG [REDACTED]  
1FM5K8ARXDG [REDACTED]  
1FM5K8AR1DG [REDACTED]  
1FM5K8AR0DG [REDACTED]

**LeeAnn Kirma**  
PVT Police Quality Program Management  
Chicago Assembly Plant /Ford Police Programs  
Cell: [REDACTED]  
[REDACTED]

---

**From:** [REDACTED]  
**Sent:** Thursday, May 01, 2014 2:34 PM  
**To:** [REDACTED]  
**Subject:** RE: Brake hose

Greg,

Would you be able to send me the full VIN numbers for the six vehicles?

Regards,  
Thomas Daavettila  
Mobil [REDACTED]

---

**From:** [REDACTED]  
**Sent:** Wednesday, April 30, 2014 10:43 AM  
**To:** [REDACTED]  
**Subject:** RE: Brake hose

Copy

Greg Hester  
DC Metropolitan Police Department  
Fleet Manager  
[REDACTED] cell

*"If I had asked people what they wanted, they would have said faster horses." — Henry Ford*

---

**From:** [REDACTED]  
**Sent:** Wednesday, April 30, 2014 10:42 AM  
**To:** [REDACTED]  
**Subject:** RE: Brake hose

Mailing address to send:  
Ford Motor Company  
Attn: Thomas Daavettila  
[REDACTED]

*Tom MacDonald  
Ford Police Programs  
Explorer, Taurus, MKS, MKT  
H-567 Heavy Truck and Transit  
Foundation Brake Engineering*



**From:** [REDACTED]

**Sent:** Wednesday, April 30, 2014 10:35 AM

**To:** [REDACTED]

**Subject:** RE: Brake hose

Tom,  
OK, Where do you want the old parts to go ?? Just need the location—so we can send -- Makes no difference to me  
LeeAnn asked for these to be shipped as below—

Hey- maybe I can cut them in half and send each of you a section of the hose –LOL

Mailing address to send:

Ford Motor Company

Attn: Thomas Daavettila

**From:** [REDACTED]

**Sent:** Tuesday, April 29, 2014 03:53 PM

**To:** [REDACTED]

**Subject:** FW: Brake hose

Hi Greg

Is it possible to ship back any of the brake hoses? Our engineering team in Dearborn would like to evaluate them. I will need each hose identified with VIN.

Mailing address to send:

Ford Motor Company

Attn: Thomas Daavettila

Thanks

**LeeAnn Kirma**

**Greg Hester**  
DC Metropolitan Police Department  
Fleet Manager



cell

*"If I had asked people what they wanted, they would have said faster horses." — Henry Ford*

---

**From:** [REDACTED]  
**Sent:** Wednesday, April 30, 2014 7:21 AM  
**To:** [REDACTED]  
**Subject:** RE: Brake hose

I am in the middle of moving offices so if we can ship to Link Engineering that would be great, if possible can I get the hose overnight shipped please.

Ford Fedex account# 4586-9364-1  
Link Engineering

Attn: Tom MacDonald / Greg Shell

*Tom MacDonald  
Ford Police Programs  
Explorer, Taurus, MKS, MKT  
H-567 Heavy Truck and Transit  
Foundation Brake Engineering*



---

**From:** [REDACTED]  
**Sent:** Wednesday, April 30, 2014 1:16 AM  
**To:** [REDACTED]  
**Subject:** RE: Brake hose

Greg,  
Would it be possible to get any of the parts for analysis?

Best Regards,

[REDACTED]

email: [REDACTED]

**From:** [REDACTED]

**Sent:** Tuesday, April 29, 2014 11:13 AM

**To:** [REDACTED]

**Subject:** FW: Brake hose

**Importance:** High

All,  
This is the 6<sup>th</sup> unit with a blown brake hose - vins are below for the others  
1FM5K8ARXDG [REDACTED] with 45,408 miles DC8218 DGA27064 45430 100471 DB5Z2078A LEFT

Here are the VINS and mileages of vehicles with brake hose problems.

TAG	VIN	MILEAGE	RO#	PART #	
DC8230	DG [REDACTED]	26147	96998	DB5Z2078A	LEFT
DC8210	DG [REDACTED]	16511	97137	DB5Z2078B	RIGHT
DC8260	DG [REDACTED]	30872	98684	BB5Z2078B	RIGHT
DC8265	DG [REDACTED]	39369	98738	DB5Z2078A	LEFT
DC8226	DG [REDACTED]	33302	99997	DB5Z2078B	RIGHT
DC8218	DG [REDACTED]	45430	100471	DB5Z2078A	LEFT

Greg Hester  
DC Metropolitan Police Department  
Fleet Manager

[REDACTED] cell

*"If I had asked people what they wanted, they would have said faster horses." — Henry Ford*

**From:** [REDACTED]

**Sent:** Tuesday, April 29, 2014 8:59 AM

**To:** [REDACTED]

**Subject:** Brake hose

[REDACTED]  
Here are the pictures on the most recent brake hose failure left front utility. We are saving the hose.

Thank You,  
Stephen Ferguson  
Operations Manager  
First Vehicle Services  
DC MPD

April is National **Financial Capability Month!**

Evaluate your financial well-being with a [free personal financial health assessment](#) provided by the D.C. Dept. of Insurance, Securities and Banking.

[DISB.DC.gov](http://DISB.DC.gov)

---

**From:** [REDACTED]  
**Sent:** Wednesday, July 23, 2014 10:10 AM  
**To:** [REDACTED]  
**Cc:** [REDACTED]  
**Subject:** RE: Brake hose- Need Resolution

Pete,

I am happy to assist...looks like you plan to be at the address below on the 29<sup>th</sup> Thru August 1st.

[REDACTED]

Stephen Ferguson  
Operations Manager  
First Vehicle Services  
DC MPD  
[REDACTED]

Please let me know when you would like me to be available.

Thanks!

*Darrell Huff (FSE)*

[REDACTED]

---

**From:** [REDACTED]  
**Sent:** Wednesday, July 23, 2014 9:02 AM  
**To:** [REDACTED]  
**Subject:** RE: Brake hose- Need Resolution

Darrell – you received the TFOAMS assignment for this.

Thanks!

*Pat*

---

**From:** [REDACTED]  
**Sent:** Tuesday, July 22, 2014 11:06 PM  
**To:** [REDACTED]  
**Subject:** FW: Brake hose- Need Resolution

Glenn

Please contact the Engineer per process and advise of field visit protocol and approve as appropriate.

Once you approve we will assign a Field Service Engineer to accompany.  
Pat once approved please issue TFOAMS for Huff.

Thanks!

[REDACTED]  
Manager, Technical Support Operations  
Ford Motor Company  
Mid Atlantic Area - USA

---

Phone: [REDACTED]  
[REDACTED]

-----Original Message-----

**From:** [REDACTED]  
**Sent:** Tuesday, July 22, 2014 03:24 PM Eastern Standard Time  
**To:** [REDACTED]  
**Subject:** RE: Brake hose- Need Resolution

**Pete,**  
**I suggest we contact the TSOM- Technical Service Operations Manager, Dave Dodds as a professional courtesy. Dave is a member in good standing in the “good guy” club and may be of assistance if requested.**

[REDACTED]

---

**From:** [REDACTED]  
**Sent:** Tuesday, July 22, 2014 2:10 PM  
**To:** [REDACTED]  
**Subject:** FW: Brake hose- Need Resolution

Chris,

Who would be the FCSD service engineer in the Washington DC area? I would like to coordinate my visit to the DC police department related to this issue. The visit would take place next week.

Thank You

[REDACTED]  
Brake Supervisor, V363, B299, D258, D385, D47X, U502, Econoline, C489  
FN3 – HS015  
313-805-4797

---

**From:** [REDACTED]  
**Sent:** Tuesday, July 22, 2014 2:02 PM

**To:** [REDACTED]

**Subject:** Re: Brake hose- Need Resolution

Ok

[REDACTED]

Greg Hester

---

**From:** [REDACTED]

**Sent:** Tuesday, July 22, 2014 01:57 PM

**To:** [REDACTED]

**Subject:** RE: Brake hose- Need Resolution

Greg,

Can you get me address of your location? I need to make travel plans, current plan is to be there morning of July 29<sup>th</sup> and return August 1<sup>st</sup>.

Thank You

[REDACTED]

Brake Supervisor, V363, B299, D258, D385, D47X, U502, Econoline, C489  
FN3 – HS015  
313-805-4797

DC Public Schools' Beautification Day is on Saturday, August 23! Roll up your sleeves and help beautify our schools. [Sign up](#) to volunteer.

---

**From:** [REDACTED]

**Sent:** Tuesday, July 22, 2014 10:37 AM

**To:** [REDACTED]

**Subject:** RE: Brake hose- Need Resolution

Sure can

- What part number was used when the hoses were replaced? **DB5Z-2078B RF --- DB5Z-2078A LF**
- Have there been any repeat failures once the hoses were replaced- **So far. No replacements have failed —as of this date**
- Are any of the parts still available to send to us, again we were able to get only 2 hoses.—**Yes I have 1 hose now, I have ordered new hoses for all the units (45) in this vin sequence, that have not been changed- I can't take the chance- Those will be replaced, starting tomorrow, so I will have plenty of hoses shortly. .**
- Is it possible to send people out and what dates would you be able to support a visit? **Yes anytime is fine –**

I have attached a vin list of the units we have had the brake hose failures— all have failed in approx. the same location- RS or LS

The 2<sup>nd</sup> order of Utilities we received in Sept of 2012- to date **Have NOT** had any hose failures --

[REDACTED]

**DC Metropolitan Police Department**

[REDACTED]  
cell

*"If I had asked people what they wanted, they would have said faster horses." — Henry Ford*

---

**From:** [REDACTED]  
**Sent:** Tuesday, July 22, 2014 10:07 AM  
**To:** [REDACTED]  
**Subject:** RE: Brake hose- Need Resolution

[REDACTED],

Can you provide some additional info. We have the 2 parts that have been returned and can set up a meeting to review the current status, I would even like to come out and review the vehicles in DC to better understand any unique duty cycles, environments, etc. that could help us in this investigation. If you could provide some feed back to the below questions it would be helpful.

- What part number was used when the hoses were replaced?
- Have there been any repeat failures once the hoses were replaced.
- Are any of the parts still available to send to us, again we were able to get only 2 hoses.
- Is it possible to send people out and what dates would you be able to support a visit?

Thank You

[REDACTED]  
Brake Supervisor, V363, B299, D258, D385, D47X, U502, Econoline, C489  
FN3 – HS015  
[REDACTED]

---

**From:** [REDACTED]  
**Sent:** Friday, July 18, 2014 7:55 AM  
**To:** [REDACTED]  
**Subject:** FW: Brake hose- Need Resolution  
**Importance:** High

[REDACTED],

What are you seeing on your end regarding this?

---

**From:** [REDACTED ]  
**Sent:** Friday, July 18, 2014 7:43 AM  
**To:** [REDACTED]  
**Subject:** RE: Brake hose- Need Resolution  
**Importance:** High

Folks,  
Need this escalated so we can get a resolution- before someone is injured or worse. This is a major safety issue – particularly with this type of vehicle application- No brakes, unable to stop the vehicle is the result after the hose failure--

MPD is continuing to have brake hose failures on the Ford PI Utility units, the 2 part numbers affected are: DB5Z-2078B RF --- DB5Z-2078A LF.

I have looped Ford in on this before, sent hoses to Ford to analyze-

Has there been a reason identified as the failure ?? and I so, what is the plan of action ?

The failures started in Dec 2013, and are continuing to fail, as of yesterday another unit towed in for no brakes- pedal goes to the floor-- I now have 2 vehicles, that both RF and LF hoses that have failed— VINS:

1FM5K8ARXDG [REDACTED] & 1FM5K8AR7DG [REDACTED]

What has been the part issue for these hoses-- DB5Z-2078B RF --- DB5Z-2078A LF ??

Info I have found:

- Looking at the vin sequence --- these were all produced under RPN- FR-284, the MSO were all received March 20<sup>th</sup> -27<sup>th</sup>, looks like production was all in March 2012-- vehicles arrived to MPD on April 9<sup>th</sup> – 23<sup>rd</sup> .
- My 2<sup>nd</sup> order of Utilities in 2012, RPN- GP-129 were received in Sept- to date no hose failures on these Utilities/vins

Extremely High Potential for a vendor supply issue for any produce in this time frame—I am attaching all the vins for this RPN-

MPD has been inspecting these hoses at the pm service- yet we continue to have hose failures -

*Before someone is involved in and accident- injury or other-, during a chase or normal operation, I am pulling these into the shop to replace both brake hoses (if hasn't been completed already)*

- **I will be asking Ford for assistance on the replacement of these hoses---**  
What other information do you need from MPD ?

VIN'S-Date location & miles for brake hoses:

- 1FM5K8AR7DG [REDACTED] LF brake hose-- miles 34,194 Date 4-23-14 - TOW IN NO BRAKES / LEAKING – LF brake hose
- 1FM5K8AR3DG [REDACTED] -- brake hose –date 4-9-14 mi 33,302 (this was not warranty-per Ford dealer, hose was twisted)
- 1FM5K8AR5DG [REDACTED] —LF brake hose—date 12-17-13 mi 26,147—Complaint was brakes low -cause was LEFT FRONT BRAKE HOSE LEAKING
- 1FM5K8AR0DG [REDACTED] —RF Brake hose –date -12-24-13 mi 16,511 - Complaint was brakes was fading – cause send To the dealer for right front brake hose leaking, lower radiator hose leaking. Correction dealer replaced rf hose and lower radiator hose
- 1FM5K8AR1DG [REDACTED] -- RF brake hose –date 2-24-14- mi- 30,872 Complaint : VEHICLE TOWED IN, BRAKES GO TO THE FLOOR Cause: right brake hose leaking
- 1FM5K8AR0DG [REDACTED] —LF brake hose-Date - 2-25-14 mi 39,369 Complaint : tow in in- No start- Cause : found l/f brake hose leaking during safety inspection of the vehicle
- 1FM5K8ARXDG [REDACTED] date 4-28-14, DC8218-DGA27064 Mi 45430 100471 DB5Z2078A LEFT hose , Complaint : BRAKES ARE VERY LOW AND NEED TO BE REPLACED Cause : NEEDS A BRAKE HOSE....WFP. checked for no brake split in brake hose leaking . replaced
- 1FM5K8ARXDG [REDACTED] - Date 5-14-14 miles 46,525 - same vehicle RF hose was replaced- on 5-14-14 Complaint: PM Service due- found bubble in hose during inspection – Cause PASSDOWN: RIGHT FRONT BRAKE HOSE HAS BUBBLE correction: send to dealer for r/f brake hose / P.T. U NOISE
- 1FM5K8AR6DG [REDACTED] - DC87213 7-7-14 miles 39,075- towed in No brakes- rf brake hose leaking- loss of fluid no brakes
- 1FM5K8AR7DG [REDACTED] - Ro102219 Date 7/1/14- found during PM service- LF brake hose leaking, miles 42.802
- 1FM5K8AR7DG [REDACTED] RO# 102595, Date- 7-17-14, miles- 43,891,— towed in no brakes- pedal goes to the floor RF brake hose blown, leaking fluid
- 1FM5K8AR6DG [REDACTED] RO100829 date 5-9-14 miles 41,504 -- tow in No brakes -- replaced RF hose
- 1FM5K8AR3DG [REDACTED] - date 6-14-14-- LF brake hose-- Dealer replaced Cheaseake Ford replaced towed in no brakes--29,789- towed in miles 29,789

Greg Hester

DC Metropolitan Police Department



Fleet Manager

cell

*"If I had asked people what they wanted, they would have said faster horses." — Henry Ford*

---

**From:** [REDACTED]  
**Sent:** Thursday, June 05, 2014 10:21 AM  
**To:** [REDACTED]  
**Subject:** RE: Brake hose

Greg – Thank you!

Tom - Please let us know if you need further info

**LeeAnn Kirma**

PVT Police Quality Program Management  
Chicago Assembly Plant /Ford Police Programs  
Cell: [REDACTED]  
[REDACTED]

---

**From:** [REDACTED]  
**Sent:** Thursday, June 05, 2014 7:53 AM  
**To:** [REDACTED]  
**Subject:** RE: Brake hose

Leeann,

Here is what I can pull from the repair orders hope this helps –  
We are checking every vehicle now for the brake hose conditions

1FM5K8AR3DG [REDACTED] - brake hose – 4-9-14 mi 33,302 (this was not warranty-per Ford dealer, hose was twisted by techs installing brake pads)

1FM5K8AR5DG [REDACTED] –LF brake hose–12-17-13 mi 26,147— **Complaint was brakes low** -cause was LEFT FRONT BRAKE HOSE LEAKING

1FM5K8AR0DG [REDACTED] –RF Brake hose --12-24-13 mi 16,511 - **Complaint was brakes was fading** –cause send To the dealer for right front brake hose leaking, lower radiator hose leaking. Correction dealer replaced rf hose and lower radiator hose

1FM5K8AR1DG [REDACTED] -- RF brake hose --2-24-14- mi- 30,872 **Complaint : VEHICLE TOWED IN, BRAKES GO TO THE FLOOR** Cause: right brake hose leaking

1FM5K8AR0DG [REDACTED] –LF brake hose-- 2-25-14 mi 39,369 **Complaint : tow in in- No start- Cause : found** If brake hose leaking during safety inspection of the vehicle

1FM5K8ARXDG [REDACTED] - DC8218 DGA27064 Mi 45430 100471 DB5Z2078A LEFT hose 4-28-14

**Complaint :** BRAKES ARE VERY LOW AND NEED TO BE REPLACED **Cause :** NEEDS A BRAKE HOSE....WFP. checked for no brake split in brake hose leaking . replaced

1FM5K8ARXDG [REDACTED] - 5-14-14 miles 46,525 - same vehicle

RF hose was replaced- on 5-14-14 Complaint: PM Service due- found bubble in hose during inspection – Cause PASSDOWN: RIGHT FRONT BRAKE HOSE HAS BUBBLE correction: send to dealer for r/f brake hose / P.T. U NOISE

[REDACTED]  
DC Metropolitan Police Department

Fleet Manager

cell

*"If I had asked people what they wanted, they would have said faster horses." — Henry Ford*

---

**From:** [REDACTED]

**Sent:** Wednesday, June 04, 2014 10:01 AM

**To:** [REDACTED]

(L.M.)

**Subject:** RE: Brake hose

Greg

Thank you for sending in the brake hoses. Our team in Dearborn has been reviewing and evaluating the hoses the last couple of weeks.

Can you provide further information regarding the duty cycle, driving/roads conditions, at failure what was noticed/observed, etc? Any further info will help regarding the analysis.

**LeeAnn Kirma**

PVT Police Quality Program Management

Chicago Assembly Plant /Ford Police Programs

Cell: [REDACTED]

---

**From:** [REDACTED]

**Sent:** Friday, May 02, 2014 11:28 AM

**To:** [REDACTED]

**Subject:** RE: Brake hose

Thank you!

[REDACTED]

---

**From:** [REDACTED]

**Sent:** Friday, May 02, 2014 10:53 AM

**To:** [REDACTED]

**Subject:** RE: Brake hose

**Delivered**

Tracking Number: 1Z9V3E750192655641

Service: UPS Next Day Air®

Weight: 4.00 lbs

Shipped/Billed On: 05/01/2014  
Delivered On: 05/02/2014 9:54 A.M.  
Delivered To: DEARBORN, MI, US  
Signed By: HILL  
Left At: Inside Delivery

Greg Hester  
DC Metropolitan Police Department  
Fleet Manager  
[REDACTED]  
[REDACTED] cell

*"If I had asked people what they wanted, they would have said faster horses." — Henry Ford*

---

**From:** [REDACTED]  
**Sent:** Friday, May 02, 2014 10:41 AM  
**To:** [REDACTED]  
**Subject:** RE: Brake hose  
**Importance:** High

Greg- thank you

Thomas- Part are on their way. Tracking info below.

**LeeAnn Kirma**  
PVT Police Quality Program Management  
Chicago Assembly Plant /Ford Police Programs  
Cell: [REDACTED]  
[REDACTED]

---

**From:** [REDACTED ]  
**Sent:** Friday, May 02, 2014 5:49 AM  
**To:** [REDACTED]  
**Subject:** RE: Brake hose  
**Importance:** High

All-  
These 2 vins make 7 units total for the brake hoses-  
VIN'S-Date location & miles for brake hoses:  
1FM5K8AR7DG [REDACTED] LF brake hose-- miles 34,194 4-23-14  
1FM5K8ARXDG [REDACTED] LF brake hose--miles- 45,430 4-28-14  
**UPS TRACKING # 1Z9V3E750192655641 OVERNIGHT to this address**

Ford Motor Company  
Attn: Thomas Daavettila  
6200 Mercury Drive  
Dearborn, MI 48126

These- were replaced prior- parts were not called for by Ford warranty to review.  
Due to the date of repair these aren't available.

1FM5K8AR3DG [redacted] -- brake hose – 4-9-14 mi 33,302 (this was not warranty-per Ford, hose was twisted by techs installing brake pads)

1FM5K8AR5DG [redacted] —LF brake hose—12-17-13 mi 26,147

1FM5K8AR0DG [redacted] —RF Brake hose --12-24-13 mi 16,511

1FM5K8AR1DG [redacted] -- RF brake hose --2-24-14- mi- 30,872

1FM5K8AR0DG [redacted] —LF brake hose-- 2-25-14 mi 39,369

Greg Hester  
DC Metropolitan Police Department  
Fleet Manager

[redacted]  
[redacted] cell

*"If I had asked people what they wanted, they would have said faster horses." — Henry Ford*

---

**From:** [redacted]

**Sent:** Thursday, May 01, 2014 3:55 PM

**To:** [redacted]

**Subject:** RE: Brake hose

Thomas

Full VIN Numbers:

1FM5K8AR3DG [redacted]

1FM5K8AR5DG [redacted]

1FM5K8AR0DG [redacted]

1FM5K8ARXDG [redacted]

1FM5K8AR1DG [redacted]

1FM5K8AR0DG [redacted]

**LeeAnn Kirma**

PVT Police Quality Program Management  
Chicago Assembly Plant /Ford Police Programs

Cell: [redacted]  
[redacted]

---

**From:** [redacted]

**Sent:** Thursday, May 01, 2014 2:34 PM

**To:** [redacted]

**Subject:** RE: Brake hose

Greg,

Would you be able to send me the full VIN numbers for the six vehicles?

Regards,

[REDACTED]

---

**From:** [REDACTED]

**Sent:** Wednesday, April 30, 2014 10:43 AM

**To:** [REDACTED]

(T.W.)

**Subject:** RE: Brake hose

Copy

**Greg Hester**

**DC Metropolitan Police Department**

**Fleet Manager**

[REDACTED]  
cell

*"If I had asked people what they wanted, they would have said faster horses." — Henry Ford*

---

**From:** MacDonald, Thomas (J.) [<mailto:tmacdon1@ford.com>]

**Sent:** Wednesday, April 30, 2014 10:42 AM

**To:** Hester, Greg (MPD); Freiburger, Randy (R.M.)

**Cc:** Kirma, LeeAnn (L.M.); Keady, Christopher (C.M.); Honeycutt, Jonathan (J.C.); Brown, Jude (J.); Daavettala, Thomas (T.W.)

**Subject:** RE: Brake hose

Mailing address to send:

**Ford Motor Company**

**Attn: Thomas Daavettala**

**6200 Mercury Drive**

**Dearborn, MI 48126**

*Tom MacDonald*

*Ford Police Programs*

*Explorer, Taurus, MKS, MKT*

*H-567 Heavy Truck and Transit*

*Foundation Brake Engineering*

[REDACTED]



---

**From:** [REDACTED]

**Sent:** Wednesday, April 30, 2014 10:35 AM

**To:** [REDACTED]

**Subject:** RE: Brake hose

[REDACTED],  
OK, Where do you want the old parts to go ?? Just need the location—so we can send -- Makes no difference to me  
LeeAnn asked for these to be shipped as below—  
Hey- maybe I can cut them in half and send each of you a section of the hose –LOL

Mailing address to send:

Ford Motor Company

Attn: Thomas Daavettila

[REDACTED]

**From:** [REDACTED] [

**Sent:** Tuesday, April 29, 2014 03:53 PM

**To:** [REDACTED]

**Subject:** FW: Brake hose

Hi Greg

Is it possible to ship back any of the brake hoses? Our engineering team in Dearborn would like to evaluate them. I will need each hose identified with VIN.

Mailing address to send:

Ford Motor Company

Attn: Thomas Daavettila

[REDACTED]

Thanks

**LeeAnn Kirma**

**Greg Hester**

**DC Metropolitan Police Department**

**Fleet Manager**

[REDACTED] cell

*"If I had asked people what they wanted, they would have said faster horses." — Henry Ford*

---

**From:** [REDACTED]  
**Sent:** Wednesday, April 30, 2014 7:21 AM  
**To:** [REDACTED]  
**Subject:** RE: Brake hose

I am in the middle of moving offices so if we can ship to Link Engineering that would be great, if possible can I get the hose overnight shipped please.

Ford Fedex account# 4586-9364-1  
Link Engineering  
[REDACTED]

Attn: Tom MacDonald / Greg Shell

*Tom MacDonald  
Ford Police Programs  
Explorer, Taurus, MKS, MKT  
H-567 Heavy Truck and Transit  
Foundation Brake Engineering*  
[REDACTED]



---

**From:** [REDACTED]  
**Sent:** Wednesday, April 30, 2014 1:16 AM  
**To:** [REDACTED]  
**Subject:** RE: Brake hose

[REDACTED],  
Would it be possible to get any of the parts for analysis?

Best Regards,

[REDACTED]  
Police/Ambulance/QVM, Supervisor  
PDC Bldg. / 1H-J21  
Phone: [REDACTED]  
[REDACTED]

---

**Sent:** Tuesday, April 29, 2014 11:13 AM  
**To:** [REDACTED]  
[REDACTED]

**Subject:** FW: Brake hose  
**Importance:** High

All,  
This is the 6<sup>th</sup> unit with a blown brake hose - vins are below for the others  
1FM5K8ARXDG [REDACTED] with 45,408 miles DC8218 DG [REDACTED] 45430 100471 DB5Z2078A LEFT

Here are the VINS and mileages of vehicles with brake hose problems.

TAG	VIN	MILEAGE	RO#	PART #	
DC8230	DG [REDACTED]	26147	96998	DB5Z2078A	LEFT
DC8210	DG [REDACTED]	16511	97137	DB5Z2078B	RIGHT
DC8260	DG [REDACTED]	30872	98684	BB5Z2078B	RIGHT
DC8265	DG [REDACTED]	39369	98738	DB5Z2078A	LEFT
DC8226	DG [REDACTED]	33302	99997	DB5Z2078B	RIGHT
DC8218	DG [REDACTED]	45430	100471	DB5Z2078A	LEFT

Greg Hester  
DC Metropolitan Police Department  
Fleet Manager  
[REDACTED] office  
[REDACTED] cell

*"If I had asked people what they wanted, they would have said faster horses." — Henry Ford*

---

**From:** [REDACTED]  
**Sent:** Tuesday, April 29, 2014 8:59 AM  
**To:** [REDACTED]  
**Subject:** Brake hose

Greg,  
Here are the pictures on the most recent brake hose failure left front utility. We are saving the hose.

Thank You,  
Stephen Ferguson  
Operations Manager  
First Vehicle Services  
DC MPD  
[REDACTED]

**April is National **Financial Capability Month!****

Evaluate your financial well-being with a [free personal financial health assessment](#) provided by the D.C. Dept. of Insurance, Securities and Banking.

[DISB.DC.gov](http://DISB.DC.gov)



---

**From:** [REDACTED]  
**Sent:** Thursday, July 31, 2014 12:54 PM  
**To:** [REDACTED]  
**Subject:** RE: Brake hose- Need Resolution

You can use CAP's Fed Ex account number 4589 3552 1 or I can e-mail the label directly.  
If you need any additional help , let me know.



Joe Cassata  
Warranty Parts Expediter

[REDACTED]



---

[REDACTED]  
**Sent:** Thursday, July 31, 2014 11:49 AM  
**To:** [REDACTED]  
**Subject:** RE: Brake hose- Need Resolution

Fed ex label.

[REDACTED]  
Brake Supervisor, V363, B299, D258, D385, D47X, U502, Econoline, C489  
FN3 – HS015

---

**From:** [REDACTED]  
**Sent:** Thursday, July 31, 2014 12:40 PM  
**To:** [REDACTED]  
**Subject:** RE: Brake hose- Need Resolution

Are you looking for a request form shipper or Fed Ex label .....or do you want to try to tag them?



Warranty Parts Expediter

Taurus, SHO, Explorer, Lincoln MKS & Police Interceptor



**From:** [Redacted]  
**Sent:** Thursday, July 31, 2014 10:51 AM  
**To:** [Redacted]  
**Subject:** RE: Brake hose- Need Resolution

Joe

We have parts at an agency that we need parts back. They are all at the DC Metro Police. What is the best way to get these returned?

**LeeAnn Kirma**  
PVT Police Quality Program Management  
Ford Motor Company  
Chicago Assembly Plant  
Cell: [Redacted]

**From:** [Redacted]  
**Sent:** Thursday, July 31, 2014 10:15 AM  
**To:** [Redacted]  
**Subject:** RE: Brake hose- Need Resolution

I could use some help getting all the jounce hoses back from the DC police. They saved them and just need a tag to ship against. We would like to get all those part for analysis.

Thank You

[Redacted]  
Brake Supervisor, V363, B299, D258, D385, D47X, U502, Econoline, C489  
FN3 – HS015  
313-805-4797

---

**From:** [REDACTED]  
**Sent:** Thursday, July 31, 2014 11:02 AM  
**To:** [REDACTED]  
**Subject:** RE: Brake hose- Need Resolution

Great. Please keep me posted.

**LeeAnn Kirma**

PVT Police Quality Program Management  
Ford Motor Company  
Chicago Assembly Plant  
Cell: [REDACTED]  
[REDACTED]

---

**From:** [REDACTED]  
**Sent:** Thursday, July 31, 2014 10:01 AM  
**To:** [REDACTED]  
**Subject:** RE: Brake hose- Need Resolution

Next Tuesday.

[REDACTED]  
Brake Supervisor, V363, B299, D258, D385, D47X, U502, Econoline, C489  
FN3 – HS015  
313-805-4797

---

**From:** [REDACTED].)  
**Sent:** Thursday, July 31, 2014 11:00 AM  
**To:** [REDACTED]  
**Subject:** RE: Brake hose- Need Resolution

Do you know when that will take place?

**LeeAnn Kirma**

PVT Police Quality Program Management  
Ford Motor Company  
Chicago Assembly Plant  
Cell: [REDACTED]  
[REDACTED]

---

**From:** [REDACTED]  
**Sent:** Thursday, July 31, 2014 9:58 AM  
**To:** [REDACTED]  
**Subject:** RE: Brake hose- Need Resolution

I can't right now. It needs to go thru CCRG review first.

[REDACTED]  
Brake Supervisor, V363, B299, D258, D385, D47X, U502, Econoline, C489

FN3 – HS015

---

**From:** [REDACTED]  
**Sent:** Thursday, July 31, 2014 10:57 AM  
**To:** [REDACTED] (E.)  
**Subject:** RE: Brake hose- Need Resolution

Pete

Any info you can update us with?

**LeeAnn Kirma**

PVT Police Quality Program Management  
Ford Motor Company  
Chicago Assembly Plant  
Cell: [REDACTED]

---

**From:** [REDACTED]  
**Sent:** Thursday, July 24, 2014 8:33 AM  
**To:** [REDACTED]  
**Subject:** RE: Brake hose- Need Resolution

Yes please hold them for me and I will take back with me. If you could please record VINS and mileage on the vehicle when they were replaced that would be helpful.

Thank You

[REDACTED]  
Brake Supervisor, V363, B299, D258, D385, D47X, U502, Econoline, C489  
FN3 – HS015  
313-805-4797

---

**From:** [REDACTED]  
**Sent:** Thursday, July 24, 2014 9:29 AM  
**To:** [REDACTED]  
**Subject:** RE: Brake hose- Need Resolution

[REDACTED],  
Due to the failures of these front brake hoses, MPD will be replacing the left & right front brake hose's on the remaining vehicles in this vin sequence, (if it hasn't already been replaced), all these failure's appear to be in this related vin sequence of units built in March 2012.

**Do you want me to hold these hoses for you to review or take back to Ford??**

There are 45 vehicles involved – to date, 12 hoses have failed and been replaced.

[REDACTED]  
**DC Metropolitan Police Department**  
**Fleet Manager**  
[REDACTED] office  
[REDACTED] cell

*"If I had asked people what they wanted, they would have said faster horses." — Henry Ford*

DC Public Schools' Beautification Day is on Saturday, August 23! Roll up your sleeves and help beautify our schools. [Sign up](#) to volunteer.

---

**From:** [REDACTED]  
**Sent:** Wednesday, July 23, 2014 9:30 AM  
**To:** [REDACTED]  
**Subject:** RE: Brake hose- Need Resolution

No you don't need to update the A-B parts. As long as the part prefix is the DB5Z those are the latest released parts and the parts you want to use.

[REDACTED]  
Brake Supervisor, V363, B299, D258, D385, D47X, U502, Econoline, C489  
FN3 – HS015  
[REDACTED]

---

**From:** [REDACTED]  
**Sent:** Wednesday, July 23, 2014 8:27 AM  
**To:** [REDACTED]  
**Subject:** RE: Brake hose- Need Resolution  
**Importance:** High

All,  
The replacement hose's came t the dealer mixed--the part numbers have changed – these are now D/Dog- C/Charlie parts numbers -  
Should we be replacing all A-B hoses with D-C hose numbers???

**Left side hose - DB5Z-2078 A is now D**  
**Right side hose -DB5Z-2078 B is now C**

Greg Hester  
DC Metropolitan Police Department  
Fleet Manager

[REDACTED] office  
[REDACTED] cell

*"If I had asked people what they wanted, they would have said faster horses." — Henry Ford*

---

**From:** [REDACTED]  
**Sent:** Tuesday, July 22, 2014 1:58 PM

**To:** [REDACTED] (W.)  
**Subject:** RE: Brake hose- Need Resolution

Greg,

Can you get me address of your location? I need to make travel plans, current plan is to be there morning of July 29<sup>th</sup> and return August 1<sup>st</sup>.

Thank You

[REDACTED]  
Brake Supervisor, V363, B299, D258, D385, D47X, U502, Econoline, C489  
FN3 – HS015  
[REDACTED]

---

**From:** [REDACTED]  
**Sent:** Tuesday, July 22, 2014 10:37 AM  
**To:** [REDACTED] (W.)  
**Subject:** RE: Brake hose- Need Resolution

Sure can

- What part number was used when the hoses were replaced? **DB5Z-2078B RF --- DB5Z-2078A LF**
- Have there been any repeat failures once the hoses were replaced- **So far. No replacements have failed —as of this date**
- Are any of the parts still available to send to us, again we were able to get only 2 hoses.—**Yes I have 1 hose now, I have ordered new hoses for all the units (45) in this vin sequence, that have not been changed- I can't take the chance- Those will be replaced, starting tomorrow, so I will have plenty of hoses shortly. .**
- Is it possible to send people out and what dates would you be able to support a visit? **Yes anytime is fine –**

I have attached a vin list of the units we have had the brake hose failures— all have failed in approx. the same location- RS or LS

The 2<sup>nd</sup> order of Utilities we received in Sept of 2012- to date **Have NOT** had any hose failures --

**Greg Hester**  
**DC Metropolitan Police Department**  
**Fleet Manager**

[REDACTED] office  
[REDACTED] cell

*"If I had asked people what they wanted, they would have said faster horses." — Henry Ford*

---

**From:** [REDACTED]  
**Sent:** Tuesday, July 22, 2014 10:07 AM  
**To:** [REDACTED]  
**Subject:** RE: Brake hose- Need Resolution

Greg,

Can you provide some additional info. We have the 2 parts that have been returned and can set up a meeting to review the current status, I would even like to come out and review the vehicles in DC to better understand any unique duty



Extremely High Potential for a vendor supply issue for any produce in this time frame—I am attaching all the vins for this RPN-

MPD has been inspecting these hoses at the pm service- yet we continue to have hose failures -

***Before someone is involved in and accident- injury or other-, during a chase or normal operation, I am pulling these into the shop to replace both brake hoses (if hasn't been completed already)***

- **I will be asking Ford for assistance on the replacement of these hoses---**  
What other information do you need from MPD ?

**VIN'S-Date location & miles for brake hoses:**

- 1FM5K8AR7DG [REDACTED] LF brake hose-- miles 34,194 Date 4-23-14 - TOW IN NO BRAKES / LEAKING – LF brake hose
- 1FM5K8AR3DG [REDACTED] -- brake hose –date 4-9-14 mi 33,302 (this was not warranty-per Ford dealer, hose was twisted)
- 1FM5K8AR5DG [REDACTED] –LF brake hose—date 12-17-13 mi 26,147—Complaint was brakes low -cause was LEFT FRONT BRAKE HOSE LEAKING
- 1FM5K8AR0DG [REDACTED] –RF Brake hose –date -12-24-13 mi 16,511 - Complaint was brakes was fading – cause send To the dealer for right front brake hose leaking, lower radiator hose leaking. Correction dealer replaced rf hose and lower radiator hose
- 1FM5K8AR1DG [REDACTED] -- RF brake hose –date 2-24-14- mi- 30,872 Complaint : VEHICLE TOWED IN, BRAKES GO TO THE FLOOR Cause: right brake hose leaking
- 1FM5K8AR0DG [REDACTED] –LF brake hose-Date - 2-25-14 mi 39,369 Complaint : tow in in- No start- Cause : found l/f brake hose leaking during safety inspection of the vehicle
- 1FM5K8ARXDG [REDACTED] date 4-28-14, DC8218-DGA27064 Mi 45430 100471 DB5Z2078A LEFT hose , Complaint : BRAKES ARE VERY LOW AND NEED TO BE REPLACED Cause : NEEDS A BRAKE HOSE....WFP. checked for no brake split in brake hose leaking . replaced
- 1FM5K8ARXDG [REDACTED] - Date 5-14-14 miles 46,525 - same vehicle RF hose was replaced- on 5-14-14 Complaint: PM Service due- found bubble in hose during inspection – Cause PASSDOWN: RIGHT FRONT BRAKE HOSE HAS BUBBLE correction: send to dealer for r/f brake hose / P.T. U NOISE
- 1FM5K8AR6DG [REDACTED] - DC87213 7-7-14 miles 39,075- towed in No brakes- rf brake hose leaking- loss of fluid no brakes
- 1FM5K8AR7DG [REDACTED] - Ro102219 Date 7/1/14- found during PM service- LF brake hose leaking, miles 42.802
- 1FM5K8AR7DG [REDACTED] RO# 102595, Date- 7-17-14, miles- 43,891,– towed in no brakes- pedal goes to the floor RF brake hose blown, leaking fluid
- 1FM5K8AR6DG [REDACTED] RO100829 date 5-9-14 miles 41,504 -- tow in No brakes -- replaced RF hose
- 1FM5K8AR3DG [REDACTED] date 6-14-14-- LF brake hose-- Dealer replaced Cheaseake Ford replaced towed in no brakes--29,789- towed in miles 29,789

Greg Hester  
DC Metropolitan Police Department  
Fleet Manager

[REDACTED]  
[REDACTED] cell

***"If I had asked people what they wanted, they would have said faster horses." — Henry Ford***

---

**From:** [REDACTED]

**Sent:** Thursday, June 05, 2014 10:21 AM

**To:** [REDACTED]

**Subject:** RE: Brake hose



Greg – Thank you!

Tom - Please let us know if you need further info

## LeeAnn Kirma

PVT Police Quality Program Management  
Chicago Assembly Plant /Ford Police Programs

Cell: [REDACTED]  
[REDACTED]

---

**From:** [REDACTED]

**Sent:** Thursday, June 05, 2014 7:53 AM

**To:** [REDACTED]

**Subject:** RE: Brake hose

Leeann,

Here is what I can pull from the repair orders hope this helps –

We are checking every vehicle now for the brake hose conditions

1FM5K8AR3DG [REDACTED] - brake hose – 4-9-14 mi 33,302 (this was not warranty-per Ford dealer, hose was twisted by techs installing brake pads)

1FM5K8AR5DG [REDACTED] –LF brake hose—12-17-13 mi 26,147— **Complaint was brakes low** -cause was LEFT FRONT BRAKE HOSE LEAKING

1FM5K8AR0DG [REDACTED] –RF Brake hose --12-24-13 mi 16,511 - **Complaint was brakes was fading** –cause send To the dealer for right front brake hose leaking, lower radiator hose leaking. Correction dealer replaced rf hose and lower radiator hose

1FM5K8AR1DG [REDACTED] -- RF brake hose --2-24-14- mi- 30,872 **Complaint : VEHICLE TOWED IN, BRAKES GO TO THE**

**FLOOR Cause:** right brake hose leaking

1FM5K8AR0DG [REDACTED] –LF brake hose-- 2-25-14 mi 39,369 **Complaint : tow in in- No start- Cause : found l/f brake hose leaking during safety inspection of the vehicle**

1FM5K8ARXDG [REDACTED] - DC8218 DGA27064 Mi 45430 100471 DB5Z2078A LEFT hose 4-28-14

**Complaint :** BRAKES ARE VERY LOW AND NEED TO BE REPLACED **Cause :** NEEDS A BRAKE HOSE....WFP. checked for no brake split in brake hose leaking . replaced

1FM5K8ARXDG [REDACTED] - 5-14-14 miles 46,525 - same vehicle

RF hose was replaced- on 5-14-14 Complaint: PM Service due- found bubble in hose during inspection – Cause PASSDOWN: RIGHT FRONT BRAKE HOSE HAS BUBBLE correction: send to dealer for r/f brake hose / P.T. U NOISE

Greg Hester

DC Metropolitan Police Department

Fleet Manager

[REDACTED]  
[REDACTED] cell

*"If I had asked people what they wanted, they would have said faster horses." — Henry Ford*

---

**From:** [REDACTED]

**Sent:** Wednesday, June 04, 2014 10:01 AM

**To:** [REDACTED]

**Subject:** RE: Brake hose

Greg

Thank you for sending in the brake hoses. Our team in Dearborn has been reviewing and evaluating the hoses the last couple of weeks.

Can you provide further information regarding the duty cycle, driving/roads conditions, at failure what was noticed/observed, etc? Any further info will help regarding the analysis.

**LeeAnn Kirma**

PVT Police Quality Program Management  
Chicago Assembly Plant /Ford Police Programs

Cell: [REDACTED]  
[REDACTED]

---

**From:** [REDACTED]  
**Sent:** Friday, May 02, 2014 11:28 AM  
**To:** [REDACTED]  
**Subject:** RE: Brake hose

Thank you!

Thomas Daavettla  
Mobil: [REDACTED]

---

**From:** [REDACTED]  
**Sent:** Friday, May 02, 2014 10:53 AM  
**To:** [REDACTED]  
**Subject:** RE: Brake hose

**Delivered**

Tracking Number: 1Z9V3E750192655641  
Service: UPS Next Day Air®  
Weight: 4.00 lbs  
Shipped/Billed On: 05/01/2014  
**Delivered On: 05/02/2014 9:54 A.M.**  
Delivered To: DEARBORN, MI, US  
**Signed By: HILL**  
**Left At: Inside Delivery**

Greg Hester  
DC Metropolitan Police Department  
Fleet Manager

[REDACTED] cell

*"If I had asked people what they wanted, they would have said faster horses." — Henry Ford*

---

**From:** [REDACTED]

**Sent:** Friday, May 02, 2014 10:41 AM

**To:** [REDACTED]

**Subject:** RE: Brake hose

**Importance:** High

Greg- thank you

Thomas- Part are on their way. Tracking info below.

**LeeAnn Kirma**

PVT Police Quality Program Management

Chicago Assembly Plant /Ford Police Programs

Cell: [REDACTED]  
[REDACTED]

---

**From:** [REDACTED]

**Sent:** Friday, May 02, 2014 5:49 AM

**To:** [REDACTED]

**Subject:** RE: Brake hose

**Importance:** High

All-

These 2 vins make 7 units total for the brake hoses-

VIN'S-Date location & miles for brake hoses:

1FM5K8AR7DG [REDACTED] LF brake hose-- miles 34,194 4-23-14

1FM5K8ARXDG [REDACTED] LF brake hose--miles- 45,430 4-28-14

**UPS TRACKING # 1Z9V3E750192655641 OVERNIGHT to this address**

Ford Motor Company  
Attn: Thomas Daavettila

[REDACTED]

These- were replaced prior- parts were not called for by Ford warranty to review.

Due to the date of repair these aren't available.

1FM5K8AR3DG [REDACTED] -- brake hose -- 4-9-14 mi 33,302 (this was not warranty-per Ford, hose was twisted by techs installing brake pads)

1FM5K8AR5DG [REDACTED] --LF brake hose--12-17-13 mi 26,147

1FM5K8AR0DG [REDACTED] --RF Brake hose --12-24-13 mi 16,511

1FM5K8AR1DG [REDACTED] -- RF brake hose --2-24-14- mi- 30,872

1FM5K8AR0DG [REDACTED] --LF brake hose-- 2-25-14 mi 39,369

Greg Hester

DC Metropolitan Police Department

Fleet Manager

[REDACTED] office  
[REDACTED] cell

*"If I had asked people what they wanted, they would have said faster horses." — Henry Ford*

---

**From:** [REDACTED]

**Sent:** Thursday, May 01, 2014 3:55 PM

**To:** [REDACTED]

**Subject:** RE: Brake hose

Thomas

Full VIN Numbers:

1FM5K8AR3DG [REDACTED]

1FM5K8AR5DG [REDACTED]

1FM5K8AR0DG [REDACTED]

1FM5K8ARXDG [REDACTED]

1FM5K8AR1DG [REDACTED]

1FM5K8AR0DG [REDACTED]

**LeeAnn Kirma**

PVT Police Quality Program Management

Chicago Assembly Plant /Ford Police Programs

Cell: [REDACTED]

---

**From:** [REDACTED]

**Sent:** Thursday, May 01, 2014 2:34 PM

**To:** [REDACTED]

**Subject:** RE: Brake hose

Greg,

Would you be able to send me the full VIN numbers for the six vehicles?

Regards,

[REDACTED]

---

**From:** [REDACTED]

**Sent:** Wednesday, April 30, 2014 10:43 AM

**To:** [REDACTED]

[REDACTED]: RE: Brake hose

Copy

Greg Hester  
DC Metropolitan Police Department  
Fleet Manager

[REDACTED]  
[REDACTED] cell

*"If I had asked people what they wanted, they would have said faster horses." — Henry Ford*

---

**From:** [REDACTED]  
**Sent:** Wednesday, April 30, 2014 10:42 AM  
**To:** [REDACTED]  
**Subject:** RE: Brake hose

Mailing address to send:  
**Ford Motor Company**  
**Attn: Thomas Daavettila**  
[REDACTED]

*Tom MacDonald*  
*Ford Police Programs*  
*Explorer, Taurus, MKS, MKT*  
*H-567 Heavy Truck and Transit*  
*Foundation Brake Engineering*  
[REDACTED]



---

**From:** [REDACTED]  
**Sent:** Wednesday, April 30, 2014 10:35 AM  
**To:** [REDACTED]  
**Cc:** [REDACTED]  
**Subject:** RE: Brake hose

Tom,  
OK, Where do you want the old parts to go ?? Just need the location—so we can send -- Makes no difference to me  
LeeAnn asked for these to be shipped as below—  
Hey- maybe I can cut them in half and send each of you a section of the hose –LOL

Mailing address to send:  
**Ford Motor Company**  
**Attn: Thomas Daavettila**  
[REDACTED]

**From:** [REDACTED]  
**Sent:** Tuesday, April 29, 2014 03:53 PM  
**To:** [REDACTED]

**Subject:** FW: Brake hose

Hi Greg

Is it possible to ship back any of the brake hoses? Our engineering team in Dearborn would like to evaluate them. I will need each hose identified with VIN.

Mailing address to send:

Ford Motor Company  
Attn: Thomas Daavetila

[REDACTED]

Thanks

**LeeAnn Kirma**

**Greg Hester**  
**DC Metropolitan Police Department**  
**Fleet Manager**

[REDACTED]

*"If I had asked people what they wanted, they would have said faster horses." — Henry Ford*

---

**From:** [REDACTED]  
**Sent:** Wednesday, April 30, 2014 7:21 AM  
**To:** [REDACTED])  
**Subject:** RE: Brake hose

I am in the middle of moving offices so if we can ship to Link Engineering that would be great, if possible can I get the hose overnight shipped please.

Ford Fedex account# 4586-9364-1  
Link Engineering

[REDACTED]

Attn: Tom MacDonald / Greg Shell

*Tom MacDonald  
Ford Police Programs  
Explorer, Taurus, MKS, MKT  
H-567 Heavy Truck and Transit  
Foundation Brake Engineering*



---

**From:** [REDACTED]  
**Sent:** Wednesday, April 30, 2014 1:16 AM  
**To:** [REDACTED]

Greg,  
Would it be possible to get any of the parts for analysis?

Best Regards,

Randy Freiburger  
Police/Ambulance/QVM, Supervisor  
PDC Bldg. / 1H-J21  
Phone: [REDACTED]

---

**From:** [REDACTED]  
**Sent:** Tuesday, April 29, 2014 11:13 AM  
**To:** [REDACTED]  
**Subject:** FW: Brake hose  
**Importance:** High

All,  
This is the 6<sup>th</sup> unit with a blown brake hose - vins are below for the others  
1FM5K8ARXDG [REDACTED] with 45,408 miles DC8218 DGA27064 45430 100471 DB5Z2078A LEFT

Here are the VINS and mileages of vehicles with brake hose problems.

TAG	VIN	MILEAGE	RO#	PART #	
DC8230	DGA [REDACTED]	26147	96998	DB5Z2078A	LEFT
DC8210	DG [REDACTED]	16511	97137	DB5Z2078B	RIGHT
DC8260	DG [REDACTED]	30872	98684	BB5Z2078B	RIGHT
DC8265	DG [REDACTED]	39369	98738	DB5Z2078A	LEFT
DC8226	DG [REDACTED]	33302	99997	DB5Z2078B	RIGHT
DC8218	DG [REDACTED]	45430	100471	DB5Z2078A	LEFT

Greg Hester  
DC Metropolitan Police Department

Fleet Manager

cell

*"If I had asked people what they wanted, they would have said faster horses." — Henry Ford*

---

**From:** [REDACTED]  
**Sent:** Tuesday, April 29, 2014 8:59 AM  
**To:** [REDACTED]  
**Subject:** Brake hose

Greg,  
Here are the pictures on the most recent brake hose failure left front utility. We are saving the hose.

Thank You,  
Stephen Ferguson  
Operations Manager  
First Vehicle Services  
DC MPD

**April is National **Financial Capability Month!****

Evaluate your financial well-being with a [free personal financial health assessment](#) provided by the D.C. Dept. of Insurance, Securities and Banking.

[DISB.DC.gov](http://DISB.DC.gov)



---

**From:** [REDACTED]  
**Sent:** Friday, July 18, 2014 12:23 PM  
**To:** [REDACTED]  
**Subject:** RE: Brake hose- Need Resolution

This is the Pre-MCR hose(effected out 04/09/2012), We have been running with the DB53 part since 04/09/2012

[REDACTED]

---

**From:** [REDACTED]  
**Sent:** Friday, July 18, 2014 12:06 PM  
**To:** [REDACTED]  
**Subject:** RE: Brake hose- Need Resolution

Is this the Mcr hose?

Sent with Good ([www.good.com](http://www.good.com))

-----Original Message-----

**From:** [REDACTED]  
**Sent:** Friday, July 18, 2014 08:43 AM Eastern Standard Time  
**To:** [REDACTED]  
**Subject:** FW: Brake hose- Need Resolution

FYI.. This is for the BB53 brake hose.

**From:** [REDACTED]  
**Sent:** Friday, July 18, 2014 8:11 AM  
**To:** [REDACTED]  
**Subject:** RE: Brake hose- Need Resolution

[REDACTED]

Who has looked at this and can you give a status update?

Thanks,

Jonathan Honeycutt  
North American Fleet, Lease and Remarketing Operations  
*Fleet Brand Marketing Manager Car/CUV/SUV/Police*

Office: [REDACTED]

**From:** [REDACTED]

**Sent:** Friday, July 18, 2014 7:43 AM

**To:** [REDACTED]

**Subject:** RE: Brake hose- Need Resolution

**Importance:** High

Folks,

Need this escalated so we can get a resolution- before someone is injured or worse. This is a major safety issue – particularly with this type of vehicle application- No brakes, unable to stop the vehicle is the result after the hose failure--

MPD is continuing to have brake hose failures on the Ford PI Utility units, the 2 part numbers affected are: DB5Z-2078B RF --- DB5Z-2078A LF.

I have looped Ford in on this before, sent hoses to Ford to analyze-

**Has there been a reason identified as the failure ?? and I so, what is the plan of action ?**

The failures started in Dec 2013, and are continuing to fail, as of yesterday another unit towed in for no brakes- pedal goes to the floor-- I now have 2 vehicles, that both RF and LF hoses that have failed— VINS:

1FM5K8ARXDG [REDACTED] & 1FM5K8AR7DG [REDACTED]

**What has been the part issue for these hoses-- DB5Z-2078B RF --- DB5Z-2078A LF ??**

Info I have found:

- Looking at the vin sequence --- these were all produced under RPN- FR-284, the MSO were all received March 20<sup>th</sup> -27<sup>th</sup>, looks like production was all in March 2012-- vehicles arrived to MPD on April 9<sup>th</sup> – 23<sup>rd</sup> .
- My 2<sup>nd</sup> order of Utilities in 2012, RPN- GP-129 were received in Sept- to date no hose failures on these Utilities/vins

Extremely High Potential for a vendor supply issue for any produce in this time frame—I am attaching all the vins for this RPN-

MPD has been inspecting these hoses at the pm service- yet we continue to have hose failures -

*Before someone is involved in and accident- injury or other-, during a chase or normal operation, I am pulling these into the shop to replace both brake hoses (if hasn't been completed already)*

- **I will be asking Ford for assistance on the replacement of these hoses---**  
What other information do you need from MPD ?

**VIN'S-Date location & miles for brake hoses:**

- 1FM5K8AR7DG [REDACTED] LF brake hose-- miles 34,194 Date 4-23-14 - TOW IN NO BRAKES / LEAKING – LF brake hose
- 1FM5K8AR3DG [REDACTED] -- brake hose –date 4-9-14 mi 33,302 (this was not warranty-per Ford dealer, hose was twisted)
- 1FM5K8AR5DG [REDACTED] —LF brake hose—date 12-17-13 mi 26,147—Complaint was brakes low -cause was LEFT FRONT BRAKE HOSE LEAKING
- 1FM5K8AR0DG [REDACTED] —RF Brake hose –date -12-24-13 mi 16,511 - Complaint was brakes was fading – cause send to the dealer for right front brake hose leaking, lower radiator hose leaking. Correction dealer replaced rf hose and lower radiator hose
- 1FM5K8AR1DG [REDACTED] -- RF brake hose –date 2-24-14- mi- 30,872 Complaint : VEHICLE TOWED IN, BRAKES GO TO THE FLOOR Cause: right brake hose leaking
- 1FM5K8AR0DG [REDACTED] —LF brake hose-Date - 2-25-14 mi 39,369 Complaint : tow in in- No start- Cause : found l/f brake hose leaking during safety inspection of the vehicle

- 1FM5K8ARXDG [REDACTED] date 4-28-14, DC8218-DGA27064 Mi 45430 100471 DB5Z2078A LEFT hose , Complaint : BRAKES ARE VERY LOW AND NEED TO BE REPLACED Cause : NEEDS A BRAKE HOSE....WFP. checked for no brake split in brake hose leaking . replaced
- 1FM5K8ARXDG [REDACTED] - Date 5-14-14 miles 46,525 - same vehicle RF hose was replaced- on 5-14-14 Complaint: PM Service due- found bubble in hose during inspection – Cause PASSDOWN: RIGHT FRONT BRAKE HOSE HAS BUBBLE correction: send to dealer for r/f brake hose / P.T. U NOISE
- 1FM5K8AR6DG [REDACTED] - DC87213 7-7-14 miles 39,075- towed in No brakes- rf brake hose leaking- loss of fluid no brakes
- 1FM5K8AR7DG [REDACTED] Ro102219 Date 7/1/14- found during PM service- LF brake hose leaking, miles 42.802
- 1FM5K8AR7DG [REDACTED] RO# 102595, Date- 7-17-14, miles- 43,891,– towed in no brakes- pedal goes to the floor RF brake hose blown, leaking fluid
- 1FM5K8AR6DG [REDACTED] RO100829 date 5-9-14 miles 41,504 -- tow in No brakes -- replaced RF hose
- 1FM5K8AR3DG [REDACTED] - date 6-14-14-- LF brake hose-- Dealer replaced Cheeseake Ford replaced towed in no brakes--29,789- towed in miles 29,789

Greg Hester  
 DC Metropolitan Police Department  
 Fleet Manager

[REDACTED]  
 [REDACTED] cell

*"If I had asked people what they wanted, they would have said faster horses." — Henry Ford*

**From:** [REDACTED]

**Sent:** Thursday, June 05, 2014 10:21 AM

**To:** [REDACTED]

**Subject:** RE: Brake hose

Greg – Thank you!

Tom - Please let us know if you need further info

**LeeAnn Kirma**

PVT Police Quality Program Management  
 Chicago Assembly Plant /Ford Police Programs

Cell: [REDACTED]  
 [REDACTED]

**From:** [REDACTED]

**Sent:** Thursday, June 05, 2014 7:53 AM

**To:** [REDACTED]

**Subject:** RE: Brake hose

Leeann,  
 Here is what I can pull from the repair orders hope this helps –  
 We are checking every vehicle now for the brake hose conditions

1FM5K8AR3DG [REDACTED] -- brake hose -- 4-9-14 mi 33,302 (this was not warranty-per Ford dealer, hose was twisted by techs installing brake pads)  
1FM5K8AR5DG [REDACTED] -- LF brake hose -- 12-17-13 mi 26,147 -- **Complaint was brakes low** -cause was LEFT FRONT BRAKE HOSE LEAKING  
1FM5K8AR0DG [REDACTED] -- RF Brake hose -- 12-24-13 mi 16,511 - **Complaint was brakes was fading** --cause send To the dealer for right front brake hose leaking, lower radiator hose leaking. Correction dealer replaced rf hose and lower radiator hose  
1FM5K8AR1DG [REDACTED] -- RF brake hose -- 2-24-14- mi- 30,872 **Complaint : VEHICLE TOWED IN, BRAKES GO TO THE FLOOR** Cause: right brake hose leaking  
1FM5K8AR0DG [REDACTED] -- LF brake hose-- 2-25-14 mi 39,369 **Complaint : tow in in- No start- Cause : found l/f brake hose leaking during safety inspection of the vehicle**  
1FM5K8ARXDG [REDACTED] - DC8218 DGA27064 Mi 45430 100471 DB5Z2078A LEFT hose 4-28-14  
**Complaint : BRAKES ARE VERY LOW AND NEED TO BE REPLACED Cause : NEEDS A BRAKE HOSE....WFP. checked for no brake split in brake hose leaking . replaced**  
1FM5K8ARXDG [REDACTED] - 5-14-14 miles 46,525 - same vehicle  
RF hose was replaced- on 5-14-14 Complaint: PM Service due- found bubble in hose during inspection -- Cause PASSDOWN: RIGHT FRONT BRAKE HOSE HAS BUBBLE correction: send to dealer for r/f brake hose / P.T. U NOISE

Greg Hester  
DC Metropolitan Police Department  
Fleet Manager  
202 576 5388 office  
202 497 0397 cell

*"If I had asked people what they wanted, they would have said faster horses." — Henry Ford*

---

**From:** [REDACTED]  
**Sent:** Wednesday, June 04, 2014 10:01 AM  
**To:** [REDACTED]  
**Subject:** RE: Brake hose

Greg

Thank you for sending in the brake hoses. Our team in Dearborn has been reviewing and evaluating the hoses the last couple of weeks.

Can you provide further information regarding the duty cycle, driving/roads conditions, at failure what was noticed/observed, etc? Any further info will help regarding the analysis.

**LeeAnn Kirma**  
PVT Police Quality Program Management  
Chicago Assembly Plant /Ford Police Programs  
Cell: [REDACTED]

---

**From:** [REDACTED]  
**Sent:** Friday, May 02, 2014 11:28 AM  
**To:** [REDACTED]

Cc: [REDACTED] J.)

Subject: RE: Brake hose

Thank you!

---

From: [REDACTED]

Sent: Friday, May 02, 2014 10:53 AM

To: [REDACTED]

Subject: RE: Brake hose

**Delivered**

Tracking Number: 1Z9V3E750192655641

Service: UPS Next Day Air®

Weight: 4.00 lbs

Shipped/Billed On: 05/01/2014

Delivered On: 05/02/2014 9:54 A.M.

Delivered To: DEARBORN, MI, US

Signed By: HILL

Left At: Inside Delivery

Greg Hester

DC Metropolitan Police Department

Fleet Manager

[REDACTED]  
cell

*"If I had asked people what they wanted, they would have said faster horses." — Henry Ford*

---

From: [REDACTED]

Sent: Friday, May 02, 2014 10:41 AM

To: [REDACTED]

Subject: RE: Brake hose

Importance: High

Greg- thank you

Thomas- Part are on their way. Tracking info below.

**LeeAnn Kirma**

PVT Police Quality Program Management

Chicago Assembly Plant /Ford Police Programs

Cell: [REDACTED]

---

**From:** [REDACTED]

**Sent:** Friday, May 02, 2014 5:49 AM

**To:** [REDACTED]

**Subject:** RE: Brake hose

**Importance:** High

All-

These 2 vins make 7 units total for the brake hoses-

VIN'S-Date location & miles for brake hoses:

1FM5K8AR7DG [REDACTED] LF brake hose-- miles 34,194 4-23-14

1FM5K8ARXDG [REDACTED] LF brake hose--miles- 45,430 4-28-14

**UPS TRACKING # 1Z9V3E750192655641 OVERNIGHT to this address**

Ford Motor Company  
Attn: Thomas Daavettila

[REDACTED]

These- were replaced prior- parts were not called for by Ford warranty to review.  
Due to the date of repair these aren't available.

1FM5K8AR3DG [REDACTED] -- brake hose -- 4-9-14 mi 33,302 (this was not warranty-per Ford, hose was twisted by techs installing brake pads)

1FM5K8AR5DG [REDACTED] --LF brake hose--12-17-13 mi 26,147

1FM5K8AR0DG [REDACTED] --RF Brake hose --12-24-13 mi 16,511

1FM5K8AR1DG [REDACTED] -- RF brake hose --2-24-14- mi- 30,872

1FM5K8AR0DG [REDACTED] --LF brake hose-- 2-25-14 mi 39,369

Greg Hester  
DC Metropolitan Police Department  
Fleet Manager

[REDACTED] cell

*"If I had asked people what they wanted, they would have said faster horses." — Henry Ford*

---

**From:** [REDACTED]

**Sent:** Thursday, May 01, 2014 3:55 PM

**To:** [REDACTED]

**Subject:** RE: Brake hose

Thomas

Full VIN Numbers:

1FM5K8AR3DG [REDACTED]  
1FM5K8AR5DG [REDACTED]  
1FM5K8AR0DG [REDACTED]

1FM5K8ARXDG  
1FM5K8AR1DG  
1FM5K8AR0DG

**LeeAnn Kirma**

PVT Police Quality Program Management  
Chicago Assembly Plant /Ford Police Programs  
Cell [REDACTED]

---

**From:** [REDACTED]  
**Sent:** Thursday, May 01, 2014 2:34 PM  
**To:** [REDACTED]  
**Subject:** RE: Brake hose

Greg,

Would you be able to send me the full VIN numbers for the six vehicles?

Regards,

---

**From:** [REDACTED]  
**Sent:** Wednesday, April 30, 2014 10:43 AM  
**To:** [REDACTED]  
(T.W.)  
**Subject:** RE: Brake hose

Copy

Greg Hester  
DC Metropolitan Police Department  
Fleet Manager

[REDACTED] cell

*"If I had asked people what they wanted, they would have said faster horses." — Henry Ford*

---

**From:** [REDACTED]  
**Sent:** Wednesday, April 30, 2014 10:42 AM  
**To:** [REDACTED]  
(T.W.)  
**Subject:** RE: Brake hose

Mailing address to send:

Ford Motor Company  
Attn: Thomas Daavettila  
6200 Mercury Drive  
Dearborn, MI 48126

*Tom MacDonald*  
*Ford Police Programs*  
*Explorer, Taurus, MKS, MKT*  
*H-567 Heavy Truck and Transit*  
*Foundation Brake Engineering*



---

**From:** [REDACTED]

**Sent:** Wednesday, April 30, 2014 10:35 AM

**To:** [REDACTED]

**Subject:** RE: Brake hose

Tom,  
OK, Where do you want the old parts to go ?? Just need the location—so we can send -- Makes no difference to me  
LeeAnn asked for these to be shipped as below—  
Hey- maybe I can cut them in half and send each of you a section of the hose –LOL

Mailing address to send:

Ford Motor Company  
Attn: Thomas Daavettila



**From:** [REDACTED]

**Sent:** Tuesday, April 29, 2014 03:53 PM



**Subject:** FW: Brake hose

Hi Greg

Is it possible to ship back any of the brake hoses? Our engineering team in Dearborn would like to evaluate them. I will need each hose identified with VIN.

Mailing address to send:

Ford Motor Company  
Attn: Thomas Daavettila





Thanks

**LeeAnn Kirma**

**Greg Hester**  
**DC Metropolitan Police Department**  
**Fleet Manager**

[REDACTED] cell

*"If I had asked people what they wanted, they would have said faster horses." — Henry Ford*

---

**From:** [REDACTED] ]  
**Sent:** Wednesday, April 30, 2014 7:21 AM  
**To:** [REDACTED]  
[REDACTED] RE: Brake hose

I am in the middle of moving offices so if we can ship to Link Engineering that would be great, if possible can I get the hose overnight shipped please.

Ford Fedex account# 4586-9364-1  
[Link Engineering](#)

[REDACTED]

Attn: Tom MacDonald / Greg Shell

*Tom MacDonald*  
*Ford Police Programs*  
*Explorer, Taurus, MKS, MKT*  
*H-567 Heavy Truck and Transit*  
*Foundation Brake Engineering*

[REDACTED]



---

**From:** [REDACTED]  
**Sent:** Wednesday, April 30, 2014 1:16 AM  
**To:** [REDACTED]  
**Subject:** RE: Brake hose

Greg,  
Would it be possible to get any of the parts for analysis?

Best Regards,

Randy Freiburger  
Police/Ambulance/QVM, Supervisor  
PDC Bldg. / 1H-J21  
Phone: [REDACTED]

---

**From:** [REDACTED]

April 29, 2014 11:13 AM

**To:** [REDACTED]

**Importance:** High

All,  
This is the 6<sup>th</sup> unit with a blown brake hose - vins are below for the others  
1FM5K8ARXDG [REDACTED] with 45,408 miles DC8218 DGA27064 45430 100471 DB5Z2078A LEFT

Here are the VINS and mileages of vehicles with brake hose problems.

TAG	VIN	MILEAGE	RO#	PART #	
DC8230	DG [REDACTED]	26147	96998	DB5Z2078A	LEFT
DC8210	DG [REDACTED]	16511	97137	DB5Z2078B	RIGHT
DC8260	DG [REDACTED]	30872	98684	BB5Z2078B	RIGHT
DC8265	DG [REDACTED]	39369	98738	DB5Z2078A	LEFT
DC8226	DG [REDACTED]	33302	99997	DB5Z2078B	RIGHT
DC8218	DG [REDACTED]	45430	100471	DB5Z2078A	LEFT

Greg Hester  
DC Metropolitan Police Department  
Fleet Manager  
[REDACTED]  
[REDACTED] cell

*"If I had asked people what they wanted, they would have said faster horses." — Henry Ford*

---

**From:** [REDACTED]  
**Sent:** Tuesday, April 29, 2014 8:59 AM  
**To:** [REDACTED]  
**Cc:** [REDACTED]  
**Subject:** Brake hose

Greg,  
Here are the pictures on the most recent brake hose failure left front utility. We are saving the hose.

Thank You,

Stephen Ferguson  
Operations Manager  
First Vehicle Services  
DC MPD

[REDACTED]  
[REDACTED]  
[REDACTED]  
Email: s [REDACTED]

**April is National Financial Capability Month!**

Evaluate your financial well-being with a [free personal financial health assessment](#) provided by the D.C. Dept. of Insurance, Securities and Banking.

[DISB.DC.gov](http://DISB.DC.gov)

---

**From:** [REDACTED]  
**Sent:** Tuesday, July 22, 2014 10:37 AM  
**To:** [REDACTED]  
**Subject:** RE: Brake hose- Need Resolution  
**Attachments:** 1FM5K8AR7DG [REDACTED] brake hose RF 001.JPG; 1FM5K8AR7DG [REDACTED] brake hose RF 006.JPG; 1FM5K8AR7DG [REDACTED] brake hose RF 007.JPG; 1FM5K8AR7DG [REDACTED] brake hose RF 008.JPG; Ford Utility Vins FR284 builds .docx

Sure can

- What part number was used when the hoses were replaced? **DB5Z-2078B RF --- DB5Z-2078A LF**
- Have there been any repeat failures once the hoses were replaced- **So far. No replacements have failed —as of this date**
- Are any of the parts still available to send to us, again we were able to get only 2 hoses.—**Yes I have 1 hose now, I have ordered new hoses for all the units (45) in this vin sequence, that have not been changed- I can't take the chance- Those will be replaced, starting tomorrow, so I will have plenty of hoses shortly. .**
- Is it possible to send people out and what dates would you be able to support a visit? **Yes anytime is fine –**

I have attached a vin list of the units we have had the brake hose failures— all have failed in approx. the same location- RS or LS

The 2<sup>nd</sup> order of Utilities we received in Sept of 2012- to date **Have NOT** had any hose failures --

**Greg Hester**  
**DC Metropolitan Police Department**  
**Fleet Manager**

*"If I had asked people what they wanted, they would have said faster horses." — Henry Ford*

---

**From:** [REDACTED]  
[REDACTED] July 22, 2014 10:07 AM  
**To:** [REDACTED]  
**Subject:** RE: Brake hose- Need Resolution

Greg,

Can you provide some additional info. We have the 2 parts that have been returned and can set up a meeting to review the current status, I would even like to come out and review the vehicles in DC to better understand any unique duty cycles, environments, etc. that could help us in this investigation. If you could provide some feed back to the below questions it would be helpful.

- What part number was used when the hoses were replaced?
- Have there been any repeat failures once the hoses were replaced.
- Are any of the parts still available to send to us, again we were able to get only 2 hoses.
- Is it possible to send people out and what dates would you be able to support a visit?

Thank You

██████████  
Brake Supervisor, V363, B299, D258, D385, D47X, U502, Econoline, C489  
FN3 – HS015  
313-805-4797

---

**From:** ██████████  
**Sent:** Friday, July 18, 2014 7:55 AM  
**To:** ██████████  
**Subject:** FW: Brake hose- Need Resolution  
**Importance:** High

██████████  
What are you seeing on your end regarding this?

---

**From:** ██████████ ]  
**Sent:** Friday, July 18, 2014 7:43 AM  
**To:** ██████████  
██████████  
**Subject:** RE: Brake hose- Need Resolution  
**Importance:** High

Folks,

Need this escalated so we can get a resolution- before someone is injured or worse. This is a major safety issue – particularly with this type of vehicle application- No brakes, unable to stop the vehicle is the result after the hose failure--

MPD is continuing to have brake hose failures on the Ford PI Utility units, the 2 part numbers affected are: DB5Z-2078B RF --- DB5Z-2078A LF.

I have looped Ford in on this before, sent hoses to Ford to analyze-

**Has there been a reason identified as the failure ?? and I so, what is the plan of action ?**

The failures started in Dec 2013, and are continuing to fail, as of yesterday another unit towed in for no brakes- pedal goes to the floor-- I now have 2 vehicles, that both RF and LF hoses that have failed— VINS:

1FM5K8ARXDG██████████ & 1FM5K8AR7DG██████████

**What has been the part issue for these hoses-- DB5Z-2078B RF --- DB5Z-2078A LF ??**

Info I have found:

- Looking at the vin sequence --- these were all produced under RPN- FR-284, the MSO were all received March 20<sup>th</sup> -27<sup>th</sup>, looks like production was all in March 2012-- vehicles arrived to MPD on April 9<sup>th</sup> – 23<sup>rd</sup> .
- My 2<sup>nd</sup> order of Utilities in 2012, RPN- GP-129 were received in Sept- to date no hose failures on these Utilities/vins

Extremely High Potential for a vendor supply issue for any produce in this time frame—I am attaching all the vins for this RPN-

MPD has been inspecting these hoses at the pm service- yet we continue to have hose failures -

*Before someone is involved in and accident- injury or other-, during a chase or normal operation, I am pulling these into the shop to replace both brake hoses (if hasn't been completed already)*

- **I will be asking Ford for assistance on the replacement of these hoses---**  
What other information do you need from MPD ?

**VIN'S-Date location & miles for brake hoses:**

- 1FM5K8AR7DG [REDACTED] LF brake hose-- miles 34,194 Date 4-23-14 - TOW IN NO BRAKES / LEAKING – LF brake hose
- 1FM5K8AR3DG [REDACTED] -- brake hose –date 4-9-14 mi 33,302 (this was not warranty-per Ford dealer, hose was twisted)
- 1FM5K8AR5DG [REDACTED] —LF brake hose—date 12-17-13 mi 26,147—Complaint was brakes low -cause was LEFT FRONT BRAKE HOSE LEAKING
- 1FM5K8AR0DG [REDACTED] —RF Brake hose —date -12-24-13 mi 16,511 - Complaint was brakes was fading – cause send To the dealer for right front brake hose leaking, lower radiator hose leaking. Correction dealer replaced rf hose and lower radiator hose
- 1FM5K8AR1DG [REDACTED] -- RF brake hose –date 2-24-14- mi- 30,872 Complaint : VEHICLE TOWED IN, BRAKES GO TO THE FLOOR Cause: right brake hose leaking
- 1FM5K8AR0DG [REDACTED] —LF brake hose-Date - 2-25-14 mi 39,369 Complaint : tow in in- No start- Cause : found l/f brake hose leaking during safety inspection of the vehicle
- 1FM5K8ARXDG [REDACTED] date 4-28-14, DC8218-DGA27064 Mi 45430 100471 DB5Z2078A LEFT hose , Complaint : BRAKES ARE VERY LOW AND NEED TO BE REPLACED Cause : NEEDS A BRAKE HOSE....WFP. checked for no brake split in brake hose leaking . replaced
- 1FM5K8ARXDG [REDACTED] - Date 5-14-14 miles 46,525 - same vehicle RF hose was replaced- on 5-14-14 Complaint: PM Service due- found bubble in hose during inspection – Cause PASSDOWN: RIGHT FRONT BRAKE HOSE HAS BUBBLE correction: send to dealer for r/f brake hose / P.T. U NOISE
- 1FM5K8AR6DG [REDACTED] - DC87213 7-7-14 miles 39,075- towed in No brakes- rf brake hose leaking- loss of fluid no brakes
- 1FM5K8AR7DG [REDACTED] - Ro102219 Date 7/1/14- found during PM service- LF brake hose leaking, miles 42.802
- 1FM5K8AR7DG [REDACTED] RO# 102595, Date- 7-17-14, miles- 43,891,— towed in no brakes- pedal goes to the floor RF brake hose blown, leaking fluid
- 1FM5K8AR6DG [REDACTED] RO100829 date 5-9-14 miles 41,504 -- tow in No brakes -- replaced RF hose
- 1FM5K8AR3DG [REDACTED] - date 6-14-14-- LF brake hose-- Dealer replaced Cheaseake Ford replaced towed in no brakes--29,789- towed in miles 29,789

**Greg Hester**  
**DC Metropolitan Police Department**  
**Fleet Manager**

[REDACTED]  
[REDACTED] cell

*"If I had asked people what they wanted, they would have said faster horses." — Henry Ford*

---

**From:** [REDACTED]  
**Sent:** Thursday, June 05, 2014 10:21 AM  
**To:** [REDACTED]  
**Cc:** [REDACTED]  
[REDACTED] Brake hose

Greg – Thank you!

Tom - Please let us know if you need further info

**LeeAnn Kirma**  
PVT Police Quality Program Management  
Chicago Assembly Plant /Ford Police Programs  
Cell: [REDACTED]

Email: [REDACTED]

---

**From:** [REDACTED]

**Sent:** Thursday, June 05, 2014 7:53 AM

**To:** [REDACTED]

**Cc:** [REDACTED]

**Subject:** RE: Brake hose

Leeann,

Here is what I can pull from the repair orders hope this helps –

We are checking every vehicle now for the brake hose conditions

1FM5K8AR3DG [REDACTED] -- brake hose – 4-9-14 mi 33,302 (this was not warranty-per Ford dealer, hose was twisted by techs installing brake pads)

1FM5K8AR5DG [REDACTED] –LF brake hose–12-17-13 mi 26,147– **Complaint was brakes low** -cause was LEFT FRONT BRAKE HOSE LEAKING

1FM5K8AR0DG [REDACTED] –RF Brake hose --12-24-13 mi 16,511 - **Complaint was brakes was fading** –cause send To the dealer for right front brake hose leaking, lower radiator hose leaking. Correction dealer replaced rf hose and lower radiator hose

1FM5K8AR1DG [REDACTED] -- RF brake hose --2-24-14- mi- 30,872 **Complaint : VEHICLE TOWED IN, BRAKES GO TO THE**

**FLOOR** Cause: right brake hose leaking

1FM5K8AR0DG [REDACTED] –LF brake hose-- 2-25-14 mi 39,369 **Complaint : tow in in- No start- Cause : found l/f brake hose leaking during safety inspection of the vehicle**

1FM5K8ARXDG [REDACTED] - DC8218 DGA27064 Mi 45430 100471 DB5Z2078A LEFT hose 4-28-14

**Complaint :** BRAKES ARE VERY LOW AND NEED TO BE REPLACED **Cause :** NEEDS A BRAKE HOSE....WFP. checked for no brake split in brake hose leaking . replaced

1FM5K8ARXDG [REDACTED] - 5-14-14 miles 46,525 - same vehicle

RF hose was replaced- on 5-14-14 Complaint: PM Service due- found bubble in hose during inspection – Cause PASSDOWN: RIGHT FRONT BRAKE HOSE HAS BUBBLE correction: send to dealer for r/f brake hose / P.T. U NOISE

Greg Hester

DC Metropolitan Police Department

Fleet Manager

[REDACTED] office

[REDACTED] cell

*"If I had asked people what they wanted, they would have said faster horses." — Henry Ford*

---

**From:** [REDACTED]

**Sent:** Wednesday, June 04, 2014 10:01 AM

**To:** [REDACTED]

**Subject:** RE: Brake hose

Greg

Thank you for sending in the brake hoses. Our team in Dearborn has been reviewing and evaluating the hoses the last couple of weeks.

Can you provide further information regarding the duty cycle, driving/roads conditions, at failure what was noticed/observed, etc? Any further info will help regarding the analysis.

**LeeAnn Kirma**

PVT Police Quality Program Management  
Chicago Assembly Plant /Ford Police Programs

Cell: [REDACTED]

---

**From:** [REDACTED]  
**Sent:** Friday, May 02, 2014 11:28 AM  
**To:** [REDACTED]  
**Subject:** RE: Brake hose

Thank you!

Thomas Daavettila  
Mobil: [REDACTED]

---

**From:** [REDACTED]  
**Sent:** Friday, May 02, 2014 10:53 AM  
**To:** [REDACTED]  
**Subject:** RE: Brake hose

**Delivered**

Tracking Number: 1Z9V3E750192655641  
Service: UPS Next Day Air®  
Weight: 4.00 lbs  
Shipped/Billed On: 05/01/2014  
**Delivered On: 05/02/2014 9:54 A.M.**  
Delivered To: DEARBORN, MI, US  
**Signed By: HILL**  
**Left At: Inside Delivery**

Greg Hester  
DC Metropolitan Police Department  
Fleet Manager  
[REDACTED] cell

*"If I had asked people what they wanted, they would have said faster horses." — Henry Ford*

---

**From:** [REDACTED]  
**Sent:** Friday, May 02, 2014 10:41 AM  
**To:** [REDACTED]  
**Subject:** RE: Brake hose  
**Importance:** High



Greg- thank you

Thomas- Part are on their way. Tracking info below.

**LeeAnn Kirma**

PVT Police Quality Program Management  
Chicago Assembly Plant /Ford Police Programs  
Cell: [REDACTED]

---

**From:** [REDACTED]  
**Sent:** Friday, May 02, 2014 5:49 AM  
**To:** [REDACTED]  
**Subject:** RE: Brake hose  
**Importance:** High

All-  
These 2 vins make 7 units total for the brake hoses-  
VIN'S-Date location & miles for brake hoses:  
1FM5K8AR7DG [REDACTED] LF brake hose-- miles 34,194 4-23-14  
1FM5K8ARXDG [REDACTED] LF brake hose--miles- 45,430 4-28-14  
**UPS TRACKING # 1Z9V3E750192655641 OVERNIGHT to this address**

Ford Motor Company  
Attn: Thomas Daavettila  
6200 Mercury Drive  
Dearborn, MI 48126

These- were replaced prior- parts were not called for by Ford warranty to review.  
Due to the date of repair these aren't available.  
1FM5K8AR3DG [REDACTED] -- brake hose -- 4-9-14 mi 33,302 (this was not warranty-per Ford, hose was twisted by techs installing brake pads)  
1FM5K8AR5DG [REDACTED] --LF brake hose--12-17-13 mi 26,147  
1FM5K8AR0DG [REDACTED] --RF Brake hose --12-24-13 mi 16,511  
1FM5K8AR1DG [REDACTED] -- RF brake hose --2-24-14- mi- 30,872  
1FM5K8AR0DG [REDACTED] --LF brake hose-- 2-25-14 mi 39,369

Greg Hester  
DC Metropolitan Police Department  
Fleet Manager  
202 576 5388 office  
202 497 0397 cell

*"If I had asked people what they wanted, they would have said faster horses." — Henry Ford*

---

**From:** [REDACTED]  
**Sent:** Thursday, May 01, 2014 3:55 PM

**To:** [REDACTED]

**Subject:** RE: Brake hose

Thomas

Full VIN Numbers:

1FM5K8AR3DG [REDACTED]  
1FM5K8AR5DG [REDACTED]  
1FM5K8AR0DG [REDACTED]  
1FM5K8ARXDG [REDACTED]  
1FM5K8AR1DG [REDACTED]  
1FM5K8AR0DG [REDACTED]

**LeeAnn Kirma**

PVT Police Quality Program Management  
Chicago Assembly Plant /Ford Police Programs  
Cell: [REDACTED]  
[REDACTED]

---

**From:** [REDACTED].)  
**Sent:** Thursday, May 01, 2014 2:34 PM  
**To:** [REDACTED]  
**Subject:** RE: Brake hose

[REDACTED]

Would you be able to send me the full VIN numbers for the six vehicles?

Regards,  
[REDACTED]

---

**From:** [REDACTED]  
**Sent:** Wednesday, April 30, 2014 10:43 AM  
**To:** [REDACTED]  
**Subject:** RE: Brake hose

Copy

Greg Hester  
DC Metropolitan Police Department  
Fleet Manager  
[REDACTED] office  
[REDACTED] cell

*"If I had asked people what they wanted, they would have said faster horses." — Henry Ford*

---

**From:** [REDACTED]  
**Sent:** Wednesday, April 30, 2014 10:42 AM  
**To:** [REDACTED]

**Subject:** RE: Brake hose

Mailing address to send:  
Ford Motor Company  
Attn: Thomas Daavettila  
6200 Mercury Drive  
Dearborn, MI 48126

*Tom MacDonald  
Ford Police Programs  
Explorer, Taurus, MKS, MKT  
H-567 Heavy Truck and Transit  
Foundation Brake Engineering*

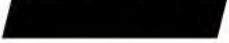

---

**From:** [REDACTED]  
**Sent:** Wednesday, April 30, 2014 10:35 AM  
**To:** [REDACTED]

**Subject:** RE: Brake hose

Tom,  
OK, Where do you want the old parts to go ?? Just need the location—so we can send -- Makes no difference to me  
LeeAnn asked for these to be shipped as below—  
Hey- maybe I can cut them in half and send each of you a section of the hose –LOL

Mailing address to send:  
Ford Motor Company  
Attn: Thomas Daavettila



---

**From:** [REDACTED]  
**Sent:** Tuesday, April 29, 2014 03:53 PM  
**To:** [REDACTED]

**Subject:** FW: Brake hose

Hi Greg

Is it possible to ship back any of the brake hoses? Our engineering team in Dearborn would like to evaluate them. I will need each hose identified with VIN.

Mailing address to send:

Ford Motor Company  
Attn: Thomas Daavettala

[REDACTED]

Thanks

**LeeAnn Kirma**

**Greg Hester**  
**DC Metropolitan Police Department**  
**Fleet Manager**

[REDACTED] office  
[REDACTED] cell

*"If I had asked people what they wanted, they would have said faster horses." — Henry Ford*

---

**From:** [REDACTED]  
**Sent:** Wednesday, April 30, 2014 7:21 AM  
**To:** [REDACTED]  
**Subject:** RE: Brake hose

I am in the middle of moving offices so if we can ship to Link Engineering that would be great, if possible can I get the hose overnight shipped please.

Ford Fedex account# 4586-9364-1  
Link Engineering

[REDACTED]

Attn: Tom MacDonald / Greg Shell

*Tom MacDonald*  
*Ford Police Programs*  
*Explorer, Taurus, MKS, MKT*  
*H-567 Heavy Truck and Transit*  
*Foundation Brake Engineering*

[REDACTED]



**From:** [REDACTED]  
**Sent:** Wednesday, April 30, 2014 1:16 AM  
**To:** [REDACTED]  
**Subject:** RE: Brake hose

Greg,  
 Would it be possible to get any of the parts for analysis?

Best Regards,

Randy Freiburger  
 Police/Ambulance/QVM, Supervisor  
 PDC Bldg. / 1H-J21  
 Phone: [REDACTED]  
 [REDACTED]

Share the Ford story at [www.TheFordStory.com](http://www.TheFordStory.com)

**Sent:** Tuesday, April 29, 2014 11:13 AM  
**To:** [REDACTED]  
**Subject:** FW: Brake hose  
**Importance:** High

All,  
 This is the 6<sup>th</sup> unit with a blown brake hose - vins are below for the others  
 1FM5K8ARXDG [REDACTED] with 45,408 miles DC8218 DGA27064 45430 100471 DB5Z2078A LEFT

Here are the VINS and mileages of vehicles with brake hose problems.

TAG	VIN	MILEAGE	RO#	PART #	
DC8230	DGA [REDACTED]	26147	96998	DB5Z2078A	LEFT
DC8210	DG [REDACTED]	16511	97137	DB5Z2078B	RIGHT
DC8260	DG [REDACTED]	30872	98684	BB5Z2078B	RIGHT
DC8265	DG [REDACTED]	39369	98738	DB5Z2078A	LEFT
DC8226	DG [REDACTED]	33302	99997	DB5Z2078B	RIGHT
DC8218	DG [REDACTED]	45430	100471	DB5Z2078A	LEFT

Greg Hester  
 DC Metropolitan Police Department  
 Fleet Manager  
 [REDACTED] office  
 [REDACTED] cell

*"If I had asked people what they wanted, they would have said faster horses." — Henry Ford*

---

**From:** [REDACTED]  
**Sent:** Tuesday, April 29, 2014 8:59 AM  
**To:** [REDACTED]  
**Subject:** Brake hose

Greg,  
Here are the pictures on the most recent brake hose failure left front utility. We are saving the hose.

Thank You,  
[REDACTED]  
Operations Manager  
First Vehicle Services  
DC MPD  
[REDACTED]

**April is National **Financial Capability Month!****

Evaluate your financial well-being with a [free personal financial health assessment](#) provided by the D.C. Dept. of Insurance, Securities and Banking.

[DISB.DC.gov](http://DISB.DC.gov)

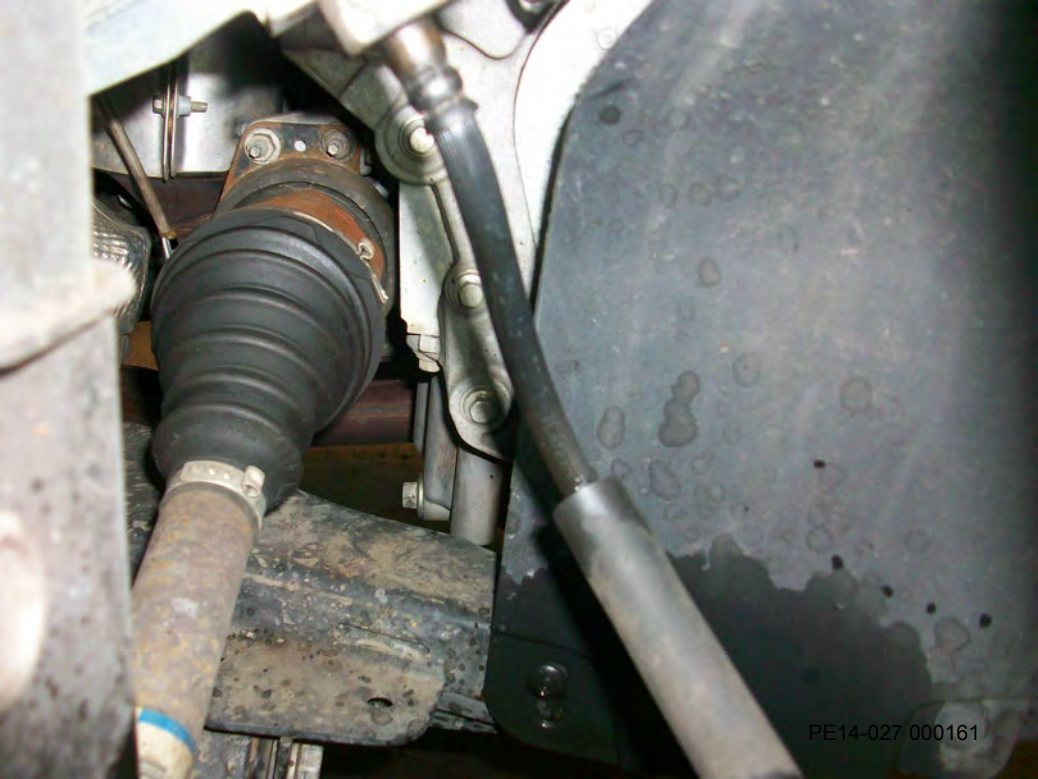

PE14-027 000161



PE14-027 000162





PE14-027 000163



PE14-027 000164

VIN #	Last 6	LF Hose	RF Hose
1FM5K8AR3D			
1FM5K8AR2D		Surveyed	7/2/2013
1FM5K8AR9D			
1FM5K8AR3D			
1FM5K8AR2D			
1FM5K8AR2D			
1FM5K8AR3D			
1FM5K8AR2D			
1FM5K8AR7D		7/1/2014	7/17/2014
1FM5K8AR6D			
1FM5K8AR4D			
1FM5K8AR4D			
1FM5K8AR0D			
1FM5K8AR9D			
1FM5K8AR1D			
1FM5K8AR8D			
1FM5K8AR0D			12/24/2013
1FM5K8AR1D			
1FM5K8ARxD			
1FM5K8AR6D			5/9/2014
1FM5K8AR0D			
1FM5K8AR1D			
1FM5K8AR3D			
1FM5K8ARXD			
1FM5K8AR8D			
1FM5K8AR5D			
1FM5K8AR9D			
1FM5K8AR3D			
1FM5K8AR5D			
1FM5K8AR1D			
		Out of vin sequence	
1FM5K8AR4D			
1FM5K8AR1D		2/25/2014	
1FM5K8AR9D			
1FM5K8AR3D			
1FM5K8AR5D			
1FM5K8AR7D			
1FM5K8AR7D			
1FM5K8AR5D			
1FM5K8AR1D			2/24/2014
1FM5K8AR4D			
1FM5K8AR7D		4/23/2014	
1FM5K8ARXD		4/28/2014	5/14/2014
1FM5K8AR6D			7/7/2014
1FM5K8AR5D			
1FM5K8AR1D			
1FM5K8AR9D			



---

**From:** [REDACTED]  
**Sent:** Monday, August 25, 2014 11:12 AM  
**To:** [REDACTED]  
**Subject:** RE: Brake hose- Need Resolution

Great. Thanks, Greg!

[REDACTED]  
Brake Engineer, PD  
Ford Motor Company USA  
[REDACTED]

---

**From:** [REDACTED ]  
**Sent:** Monday, August 25, 2014 11:05 AM  
**To:** [REDACTED]  
**Subject:** RE: Brake hose- Need Resolution

Thanks OK- We will pull 2 from the 1<sup>st</sup> vins [REDACTED] thru [REDACTED] and 2 from the 2<sup>nd</sup> vins [REDACTED] thru [REDACTED]

**Greg Hester**  
**DC Metropolitan Police Department**  
**Fleet Manager**  
[REDACTED] cell

*"If I had asked people what they wanted, they would have said faster horses." — Henry Ford*

---

**From:** [REDACTED ]  
**Sent:** Monday, August 25, 2014 11:02 AM  
**To:** [REDACTED]  
**Subject:** RE: Brake hose- Need Resolution

Greg,

4 sets of hoses were sent out today. Fedex tracking number is 7709 2639 4491. They should arrive tomorrow. You can just pull 4 random sets out of the whole group. Is that okay Pete?

Regards,  
**Christine Vandeyar**  
Brake Engineer, PD  
Ford Motor Company USA  
[REDACTED]

From: [REDACTED]

Sent: Monday, August 25, 2014 10:46 AM

To: [REDACTED]

Subject: RE: Brake hose- Need Resolution

Importance: High

[REDACTED]

How many units do you want to replace the hose's on ??

Any idea on timeframe when the parts will be sent ??

There are 45 total in the 2<sup>nd</sup> batch of vehicles--here are the vins -

32 units- [REDACTED] thru [REDACTED]

13 units [REDACTED] thru [REDACTED]

If you want - send 5 sets- I will pull 3 in the 1<sup>st</sup> set of vins [REDACTED] thru [REDACTED] & pull 2 units in the 2<sup>nd</sup> vin spread

[REDACTED] thru [REDACTED]

Eg	Yr - Make	Vins
[REDACTED]	2013 FORD UTILITY	1FM5K8AR1DG
[REDACTED]	2013 FORD UTILITY PT	1FM5K8AR8DG
[REDACTED]	2013 FORD UTILITY	1FM5K8ARXDG
[REDACTED]	2013 FORD UTILITY	1FM5K8AR1DG
[REDACTED]	2013 FORD UTILITY	1FM5K8AR3DG
[REDACTED]	2013 FORD UTILITY	1FM5K8AR5DG
[REDACTED]	2013 FORD UTILITY PT	1FM5K8AR7DG
[REDACTED]	2013 FORD UTILITY PT	1FM5K8AR9DG
[REDACTED]	2013 FORD UTILITY	1FM5K8AR0DG
[REDACTED]	2013 FORD UTILITY PT	1FM5K8AR2DG
[REDACTED]	2013 FORD UTILITY PT	1FM5K8AR4DG
[REDACTED]	2013 FORD UTILITY PT	1FM5K8AR0DG
[REDACTED]	2013 FORD UTILITY PT	1FM5K8AR2DG
[REDACTED]	2013 FORD UTILITY PT	1FM5K8AR4DG
[REDACTED]	2013 FORD UTILITY PT	1FM5K8AR6DG
[REDACTED]	2013 FORD UTILITY PT	1FM5K8AR8DG
[REDACTED]	2013 FORD UTILITY PT	1FM5K8ARXDG
[REDACTED]	2013 FORD UTILITY PT	1FM5K8AR1DG
[REDACTED]	2013 FORD UTILITY	1FM5K8AR3DG
[REDACTED]	2013 FORD UTILITY	1FM5K8AR5DG
[REDACTED]	2013 FORD UTILITY PT	1FM5K8AR7DG
[REDACTED]	2013 FORD UTILITY PT	1FM5K8AR3DG
[REDACTED]	2013 FORD UTILITY PT	1FM5K8AR5DG
[REDACTED]	2013 FORD UTILITY	1FM5K8AR7DG
[REDACTED]	2013 FORD UTILITY PT	1FM5K8AR9DG
[REDACTED]	2013 FORD UTILITY PT	1FM5K8AR0DG
[REDACTED]	2013 FORD UTILITY PT	1FM5K8AR2DG
[REDACTED]	2013 FORD UTILITY PT	1FM5K8AR4DG
[REDACTED]	2013 FORD UTILITY PT	1FM5K8AR6DG
[REDACTED]	2013 FORD UTILITY PT	1FM5K8AR8DG
[REDACTED]	2013 FORD UTILITY PT	1FM5K8ARXDG
[REDACTED]	2013 FORD UTILITY PT	1FM5K8AR6DG
[REDACTED]	2013 FORD UTILITY PT	1FM5K8AR5DG
[REDACTED]	2013 FORD UTILITY	1FM5K8AR7DG
[REDACTED]	2013 FORD UTILITY	1FM5K8AR0DG
[REDACTED]	2013 FORD UTILITY	1FM5K8AR2DG
[REDACTED]	2013 FORD UTILITY	1FM5K8AR9DG
[REDACTED]	2013 FORD UTILITY	1FM5K8AR0DG

2013 FORD UTILITY PT	1FM5K8AR2DG
2013 FORD UTILITY	1FM5K8AR4DG
2013 FORD UTILITY	1FM5K8AR6DG
2013 FORD UTILITY	1FM5K8AR8DG
2013 FORD UTILITY	1FM5K8ARXDG
2013 FORD UTILITY	1FM5K8AR1DG
2013 FORD UTILITY	1FM5K8AR3DG

Greg Hester  
DC Metropolitan Police Department  
Fleet Manager

office  
cell

*"If I had asked people what they wanted, they would have said faster horses." — Henry Ford*

---

**From:** [REDACTED]

**Sent:** Wednesday, August 20, 2014 11:48 AM

**To:** [REDACTED]

**Subject:** RE: Brake hose- Need Resolution

Christine,

Please work with Greg and his team to get him some replacement parts to support a part swap from a couple of the Explorer units. Address below to ship.

[REDACTED]  
Greg Hester

Pete Williams  
Brake Supervisor, V363, B299, D258, D385, D47X, U502, Econoline, C489  
FN3 – HS015  
313-805-4797

---

**From:** [REDACTED]

**Sent:** Tuesday, August 19, 2014 3:19 PM

**To:** [REDACTED]

**Subject:** RE: Brake hose- Need Resolution

Yes Pete, we sure can  
Let me know the details.

Sent from my Verizon Wireless 4G LTE smartphone

----- Original message -----

From: "[REDACTED]"  
Date: 08/19/2014 2:51 PM (GMT-05:00)  
To: "[REDACTED]"  
Subject: RE: Brake hose- Need Resolution

Greg,

Would you be willing to remove some of the jounce hoses off the second batch of Explorers that have not experienced any leaks and return to Ford to help with the investigation? I can arrange to ship you the replacement parts.

Thank You

[REDACTED]  
Brake Supervisor, V363, B299, D258, D385, D47X, U502, Econoline, C489  
FN3 – HS015  
[REDACTED]

Help DC become an [Age-Friendly](#) city by participating in the Block-by-Block Walk on Saturday, September 6. Sign up [here](#) to volunteer.

---

**From:** [REDACTED] ]  
**Sent:** Friday, August 01, 2014 9:26 AM  
**To:** [REDACTED]  
**Subject:** RE: Brake hose- Need Resolution  
**Importance:** High

Pete  
Does Ford want the hoses shipped ?? and if so, can you provide a ship to location.

[REDACTED]  
DC Metropolitan Police Department  
Fleet Manager  
[REDACTED] cell

*"If I had asked people what they wanted, they would have said faster horses." — Henry Ford*

---

**From:** [REDACTED]  
**Sent:** Friday, July 25, 2014 1:58 PM  
**To:** [REDACTED]  
**Subject:** RE: Brake hose- Need Resolution

Greg,



What time Wednesday morning works best for you for me to be there?

Thank You

██████████  
Brake Supervisor, V363, B299, D258, D385, D47X, U502, Econoline, C489  
FN3 – HS015  
██████████

---

**From:** ██████████  
**Sent:** Wednesday, July 23, 2014 9:34 AM  
**To:** ██████████  
**Subject:** Re: Brake hose- Need Resolution

Thanks

---

**From:** ██████████  
**Sent:** Wednesday, July 23, 2014 09:30 AM  
**To:** ██████████  
**Cc:** ██████████  
**Subject:** RE: Brake hose- Need Resolution

No you don't need to update the A-B parts. As long as the part prefix is the DB5Z those are the latest released parts and the parts you want to use.

██████████  
Brake Supervisor, V363, B299, D258, D385, D47X, U502, Econoline, C489  
FN3 – HS015  
██████████

DC Public Schools' Beautification Day is on Saturday, August 23! Roll up your sleeves and help beautify our schools. [Sign up](#) to volunteer.

---

**From:** ██████████  
**Sent:** Wednesday, July 23, 2014 8:27 AM  
**To:** ██████████  
**Subject:** RE: Brake hose- Need Resolution  
**Importance:** High

All,  
The replacement hose's came t the dealer mixed--the part numbers have changed – these are now D/Dog- C/Charlie parts numbers -  
Should we be replacing all A-B hoses with D-C hose numbers???

**Left side hose - DB5Z-2078 A is now D**  
**Right side hose -DB5Z-2078 B is now C**

Greg Hester  
DC Metropolitan Police Department

Fleet Manager

cell

*"If I had asked people what they wanted, they would have said faster horses." — Henry Ford*

---

**From:** [REDACTED]  
**Sent:** Tuesday, July 22, 2014 1:58 PM  
**To:** [REDACTED]  
**Subject:** RE: Brake hose- Need Resolution

Greg,

Can you get me address of your location? I need to make travel plans, current plan is to be there morning of July 29<sup>th</sup> and return August 1<sup>st</sup>.

Thank You

[REDACTED]  
Brake Supervisor, V363, B299, D258, D385, D47X, U502, Econoline, C489  
FN3 – HS015  
[REDACTED]

---

**From:** [REDACTED]  
**Sent:** Tuesday, July 22, 2014 10:37 AM  
**To:** [REDACTED]  
**Subject:** RE: Brake hose- Need Resolution

Sure can

- What part number was used when the hoses were replaced? DB5Z-2078B RF --- DB5Z-2078A LF
- Have there been any repeat failures once the hoses were replaced- So far. No replacements have failed —as of this date
- Are any of the parts still available to send to us, again we were able to get only 2 hoses.—Yes I have 1 hose now, I have ordered new hoses for all the units (45) in this vin sequence, that have not been changed- I can't take the chance- Those will be replaced, starting tomorrow, so I will have plenty of hoses shortly. .
- Is it possible to send people out and what dates would you be able to support a visit? Yes anytime is fine –

I have attached a vin list of the units we have had the brake hose failures— all have failed in approx. the same location- RS or LS

The 2<sup>nd</sup> order of Utilities we received in Sept of 2012- to date Have NOT had any hose failures --

Greg Hester  
DC Metropolitan Police Department  
Fleet Manager

cell

*"If I had asked people what they wanted, they would have said faster horses." — Henry Ford*

---

**From:** [REDACTED]  
**Sent:** Tuesday, July 22, 2014 10:07 AM  
**To:** [REDACTED]  
**Subject:** RE: Brake hose- Need Resolution

Greg,

Can you provide some additional info. We have the 2 parts that have been returned and can set up a meeting to review the current status, I would even like to come out and review the vehicles in DC to better understand any unique duty cycles, environments, etc. that could help us in this investigation. If you could provide some feed back to the below questions it would be helpful.

- What part number was used when the hoses were replaced?
- Have there been any repeat failures once the hoses were replaced.
- Are any of the parts still available to send to us, again we were able to get only 2 hoses.
- Is it possible to send people out and what dates would you be able to support a visit?

Thank You

[REDACTED]  
Brake Supervisor, V363, B299, D258, D385, D47X, U502, Econoline, C489  
FN3 – HS015  
[REDACTED]

---

**From:** [REDACTED]  
**Sent:** Friday, July 18, 2014 7:55 AM  
**To:** [REDACTED]  
**Subject:** FW: Brake hose- Need Resolution  
**Importance:** High

Steve,

What are you seeing on your end regarding this?

---

**From:** [REDACTED]  
**Sent:** Friday, July 18, 2014 7:43 AM  
**To:** [REDACTED]  
**Subject:** RE: Brake hose- Need Resolution  
**Importance:** High

Folks,

Need this escalated so we can get a resolution- before someone is injured or worse. This is a major safety issue – particularly with this type of vehicle application- No brakes, unable to stop the vehicle is the result after the hose failure--

MPD is continuing to have brake hose failures on the Ford PI Utility units, the 2 part numbers affected are: DB5Z-2078B RF --- DB5Z-2078A LF.

I have looped Ford in on this before, sent hoses to Ford to analyze-

Has there been a reason identified as the failure ?? and I so, what is the plan of action ?

The failures started in Dec 2013, and are continuing to fail, as of yesterday another unit towed in for no brakes- pedal goes to the floor-- I now have 2 vehicles, that both RF and LF hoses that have failed— VINS:

1FM5K8ARXDG [REDACTED] & 1FM5K8AR7DG [REDACTED]

What has been the part issue for these hoses-- DB5Z-2078B RF --- DB5Z-2078A LF ??

Info I have found:

- Looking at the vin sequence --- these were all produced under RPN- FR-284, the MSO were all received March 20<sup>th</sup> -27<sup>th</sup>, looks like production was all in March 2012-- vehicles arrived to MPD on April 9<sup>th</sup> – 23<sup>rd</sup>.
- My 2<sup>nd</sup> order of Utilities in 2012, RPN- GP-129 were received in Sept- to date no hose failures on these Utilities/vins

Extremely High Potential for a vendor supply issue for any produce in this time frame—I am attaching all the vins for this RPN-

MPD has been inspecting these hoses at the pm service- yet we continue to have hose failures -

*Before someone is involved in and accident- injury or other-, during a chase or normal operation, I am pulling these into the shop to replace both brake hoses (if hasn't been completed already)*

- **I will be asking Ford for assistance on the replacement of these hoses---**  
What other information do you need from MPD ?

VIN'S-Date location & miles for brake hoses:

- 1FM5K8AR7DG [REDACTED] LF brake hose-- miles 34,194 Date 4-23-14 - TOW IN NO BRAKES / LEAKING – LF brake hose
- 1FM5K8AR3DG [REDACTED] -- brake hose –date 4-9-14 mi 33,302 (this was not warranty-per Ford dealer, hose was twisted)
- 1FM5K8AR5DG [REDACTED] —LF brake hose—date 12-17-13 mi 26,147—Complaint was brakes low -cause was LEFT FRONT BRAKE HOSE LEAKING
- 1FM5K8AR0DG [REDACTED] —RF Brake hose —date -12-24-13 mi 16,511 - Complaint was brakes was fading – cause send To the dealer for right front brake hose leaking, lower radiator hose leaking. Correction dealer replaced rf hose and lower radiator hose
- 1FM5K8AR1DG [REDACTED] - RF brake hose –date 2-24-14- mi- 30,872 Complaint : VEHICLE TOWED IN, BRAKES GO TO THE FLOOR Cause: right brake hose leaking
- 1FM5K8AR0DG [REDACTED] —LF brake hose-Date - 2-25-14 mi 39,369 Complaint : tow in in- No start- Cause : found l/f brake hose leaking during safety inspection of the vehicle
- 1FM5K8ARXDG [REDACTED] date 4-28-14, DC8218-DGA27064 Mi 45430 100471 DB5Z2078A LEFT hose , Complaint : BRAKES ARE VERY LOW AND NEED TO BE REPLACED Cause : NEEDS A BRAKE HOSE....WFP. checked for no brake split in brake hose leaking . replaced
- 1FM5K8ARXDG [REDACTED] - Date 5-14-14 miles 46,525 - same vehicle RF hose was replaced- on 5-14-14 Complaint: PM Service due- found bubble in hose during inspection – Cause PASSDOWN: RIGHT FRONT BRAKE HOSE HAS BUBBLE correction: send to dealer for r/f brake hose / P.T. U NOISE
- 1FM5K8AR6DG [REDACTED] - DC87213 7-7-14 miles 39,075- towed in No brakes- rf brake hose leaking- loss of fluid no brakes
- 1FM5K8AR7DG [REDACTED] Ro102219 Date 7/1/14- found during PM service- LF brake hose leaking, miles 42,802
- 1FM5K8AR7DG [REDACTED] RO# 102595, Date- 7-17-14, miles- 43,891,— towed in no brakes- pedal goes to the floor RF brake hose blown, leaking fluid
- 1FM5K8AR6DG [REDACTED] RO100829 date 5-9-14 miles 41,504 -- tow in No brakes -- replaced RF hose
- 1FM5K8AR3DG [REDACTED] - date 6-14-14-- LF brake hose-- Dealer replaced Cheaseake Ford replaced towed in no brakes--29,789- towed in miles 29,789

Greg Hester

DC Metropolitan Police Department

Fleet Manager

[REDACTED] office  
[REDACTED] cell

**"If I had asked people what they wanted, they would have said faster horses." — Henry Ford**

---

**From:** [REDACTED]

**Sent:** Thursday, June 05, 2014 10:21 AM

**To:** [REDACTED]

**Subject:** RE: Brake hose

Greg – Thank you!

Tom - Please let us know if you need further info

### LeeAnn Kirma

PVT Police Quality Program Management

Chicago Assembly Plant /Ford Police Programs

Cell: [REDACTED]

---

**From:** [REDACTED]

**Sent:** Thursday, June 05, 2014 7:53 AM

**To:** [REDACTED]

**Subject:** RE: Brake hose

Leeann,

Here is what I can pull from the repair orders hope this helps –

We are checking every vehicle now for the brake hose conditions

1FM5K8AR3DG [REDACTED] -- brake hose – 4-9-14 mi 33,302 (this was not warranty-per Ford dealer, hose was twisted by techs installing brake pads)

1FM5K8AR5DG [REDACTED] —LF brake hose—12-17-13 mi 26,147— **Complaint was brakes low** -cause was LEFT FRONT BRAKE HOSE LEAKING

1FM5K8AR0DG [REDACTED] —RF Brake hose --12-24-13 mi 16,511 - **Complaint was brakes was fading** —cause send To the dealer for right front brake hose leaking, lower radiator hose leaking. Correction dealer replaced rf hose and lower radiator hose

1FM5K8AR1DG [REDACTED] -- RF brake hose --2-24-14- mi- 30,872 **Complaint : VEHICLE TOWED IN, BRAKES GO TO THE FLOOR** Cause: right brake hose leaking

1FM5K8AR0DG [REDACTED] —LF brake hose-- 2-25-14 mi 39,369 **Complaint : tow in in- No start- Cause : found If brake hose leaking during safety inspection of the vehicle**

1FM5K8ARXDG [REDACTED] - DC8218 DGA27064 Mi 45430 100471 DB5Z2078A LEFT hose 4-28-14

**Complaint :** BRAKES ARE VERY LOW AND NEED TO BE REPLACED **Cause :** NEEDS A BRAKE HOSE....WFP. checked for no brake split in brake hose leaking . replaced

1FM5K8ARXDG [REDACTED] - 5-14-14 miles 46,525 - same vehicle

RF hose was replaced- on 5-14-14 Complaint: PM Service due- found bubble in hose during inspection – Cause PASSDOWN: RIGHT FRONT BRAKE HOSE HAS BUBBLE correction: send to dealer for r/f brake hose / P.T. U NOISE

Greg Hester

DC Metropolitan Police Department

Fleet Manager

[REDACTED] office  
[REDACTED] cell

***"If I had asked people what they wanted, they would have said faster horses." — Henry Ford***

---

**From:** [REDACTED]

**Sent:** Wednesday, June 04, 2014 10:01 AM

**To:** [REDACTED]

**Subject:** RE: Brake hose

Greg

Thank you for sending in the brake hoses. Our team in Dearborn has been reviewing and evaluating the hoses the last couple of weeks.

Can you provide further information regarding the duty cycle, driving/roads conditions, at failure what was noticed/observed, etc? Any further info will help regarding the analysis.

**LeeAnn Kirma**

PVT Police Quality Program Management

Chicago Assembly Plant /Ford Police Programs

Cell: [REDACTED]  
[REDACTED]

---

**From:** [REDACTED]

**Sent:** Friday, May 02, 2014 11:28 AM

**To:** [REDACTED]

**Subject:** RE: Brake hose

Thank you!

[REDACTED]

---

**From:** [REDACTED]

**Sent:** Friday, May 02, 2014 10:53 AM

**To:** [REDACTED]

**Subject:** RE: Brake hose

**Delivered**

Tracking Number: 1Z9V3E750192655641

Service: UPS Next Day Air®

Weight: 4.00 lbs

Shipped/Billed On: 05/01/2014

**Delivered On: 05/02/2014 9:54 A.M.**

Delivered To: DEARBORN, MI, US

Signed By: HILL

Left At: Inside Delivery

Greg Hester  
DC Metropolitan Police Department  
Fleet Manager  
[redacted] office  
[redacted] cell

*"If I had asked people what they wanted, they would have said faster horses." — Henry Ford*

---

**From:** [redacted]  
**Sent:** Friday, May 02, 2014 10:41 AM  
**To:** [redacted]  
**Subject:** RE: Brake hose  
**Importance:** High

Greg- thank you

Thomas- Part are on their way. Tracking info below.

**LeeAnn Kirma**

PVT Police Quality Program Management  
Chicago Assembly Plant /Ford Police Programs  
Cell: [redacted]  
[redacted]

---

**From:** [redacted]  
**Sent:** Friday, May 02, 2014 5:49 AM  
**To:** [redacted]  
**Subject:** RE: Brake hose  
**Importance:** High

All-

These 2 vins make 7 units total for the brake hoses-

VIN'S-Date location & miles for brake hoses:

1FM5K8AR7DG [redacted] LF brake hose-- miles 34,194 4-23-14

1FM5K8ARXDG [redacted] LF brake hose--miles- 45,430 4-28-14

**UPS TRACKING # 1Z9V3E750192655641 OVERNIGHT to this address**

Ford Motor Company  
Attn: Thomas Daavettila

[redacted]

These- were replaced prior- parts were not called for by Ford warranty to review.  
Due to the date of repair these aren't available.

1FM5K8AR3DG [redacted] -- brake hose – 4-9-14 mi 33,302 (this was not warranty-per Ford, hose was twisted by techs installing brake pads)

1FM5K8AR5DG [redacted] —LF brake hose—12-17-13 mi 26,147

1FM5K8AR0DG [redacted] —RF Brake hose --12-24-13 mi 16,511

1FM5K8AR1DG [REDACTED] -- RF brake hose --2-24-14- mi- 30,872

1FM5K8AR0DG [REDACTED] -- LF brake hose-- 2-25-14 mi 39,369

Greg Hester  
DC Metropolitan Police Department  
Fleet Manager

[REDACTED]  
[REDACTED] cell

*"If I had asked people what they wanted, they would have said faster horses." — Henry Ford*

---

**From:** [REDACTED]

**Sent:** Thursday, May 01, 2014 3:55 PM

**To:** [REDACTED]

**Subject:** RE: Brake hose

Thomas

Full VIN Numbers:

1FM5K8AR3D [REDACTED]  
1FM5K8AR5D [REDACTED]  
1FM5K8AR0D [REDACTED]  
1FM5K8ARXD [REDACTED]  
1FM5K8AR1D [REDACTED]  
1FM5K8AR0D [REDACTED]

**LeeAnn Kirma**

PVT Police Quality Program Management  
Chicago Assembly Plant /Ford Police Programs

Cell: [REDACTED]  
[REDACTED]

---

**From:** [REDACTED]

**Sent:** Thursday, May 01, 2014 2:34 PM

**To:** [REDACTED]

**Subject:** RE: Brake hose

Greg,

Would you be able to send me the full VIN numbers for the six vehicles?

Regards,  
[REDACTED]



Mobil: [REDACTED]

---

**From:** [REDACTED]

**Sent:** Wednesday, April 30, 2014 10:43 AM

**To:** [REDACTED]

**Subject:** RE: Brake hose

Copy

Greg Hester  
DC Metropolitan Police Department  
Fleet Manager

[REDACTED] office  
[REDACTED] cell

*"If I had asked people what they wanted, they would have said faster horses." — Henry Ford*

---

**From:** [REDACTED]

**Sent:** Wednesday, April 30, 2014 10:42 AM

**To:** [REDACTED]

**Subject:** RE: Brake hose

Mailing address to send:  
**Ford Motor Company**  
Attn: Thomas Daavettila

[REDACTED]

*Tom MacDonald  
Ford Police Programs  
Explorer, Taurus, MKS, MKT  
H-567 Heavy Truck and Transit  
Foundation Brake Engineering*

[REDACTED]



---

**From:** [REDACTED]

**Sent:** Wednesday, April 30, 2014 10:35 AM

**To:** [REDACTED]

**Subject:** RE: Brake hose

[REDACTED],  
OK, Where do you want the old parts to go ?? Just need the location—so we can send -- Makes no difference to me  
LeeAnn asked for these to be shipped as below—  
Hey- maybe I can cut them in half and send each of you a section of the hose –LOL

Mailing address to send:

Ford Motor Company  
Attn: Thomas Daavettila

[REDACTED]

**From:** [REDACTED]  
**Sent:** Tuesday, April 29, 2014 03:53 PM  
**To:** [REDACTED]

[REDACTED]

**Subject:** FW: Brake hose

Hi Greg

Is it possible to ship back any of the brake hoses? Our engineering team in Dearborn would like to evaluate them. I will need each hose identified with VIN.

Mailing address to send:

Ford Motor Company  
Attn: Thomas Daavettila

[REDACTED]

Thanks

**LeeAnn Kirma**

**Greg Hester**  
DC Metropolitan Police Department  
Fleet Manager

[REDACTED] office  
[REDACTED] cell

*"If I had asked people what they wanted, they would have said faster horses." — Henry Ford*

---

**From:** [REDACTED]  
**Sent:** Wednesday, April 30, 2014 7:21 AM  
**To:** [REDACTED])  
**Subject:** RE: Brake hose

I am in the middle of moving offices so if we can ship to Link Engineering that would be great, if possible can I get the hose overnight shipped please.

Ford Fedex account# 4586-9364-1  
Link Engineering



Attn: Tom MacDonald / Greg Shell

*Tom MacDonald  
Ford Police Programs  
Explorer, Taurus, MKS, MKT  
H-567 Heavy Truck and Transit  
Foundation Brake Engineering*

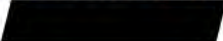

---

**From:** [REDACTED]  
**Sent:** Wednesday, April 30, 2014 1:16 AM  
**To:** [REDACTED]  
**Subject:** RE: Brake hose

Greg,  
Would it be possible to get any of the parts for analysis?

Best Regards,

Randy Freiburger  
Police/Ambulance/QVM, Supervisor  
PDC Bldg. / 1H-J21  
Phone: [REDACTED]

Share the Ford story at [www.TheFordStory.com](http://www.TheFordStory.com)

---

**From:** [REDACTED]  
[REDACTED]  
**Subject:** FW: Brake hose  
**Importance:** High

All,  
This is the 6<sup>th</sup> unit with a blown brake hose - vins are below for the others  
1FM5K8ARXDG [REDACTED] with 45,408 miles DC8218 DG [REDACTED] [REDACTED] [REDACTED] DB5 [REDACTED] LEFT

Here are the VINS and mileages of vehicles with brake hose problems.

TAG	VIN	MILEAGE	RO#	PART #	
DC8230	DGA [REDACTED]	26147	96998	DB5Z2078A	LEFT
DC8210	DG [REDACTED]	16511	97137	DB5Z2078B	RIGHT
DC8260	DG [REDACTED]	30872	98684	BB5Z2078B	RIGHT
DC8265	DG [REDACTED]	39369	98738	DB5Z2078A	LEFT
DC8226	DG [REDACTED]	33302	99997	DB5Z2078B	RIGHT
DC8218	DG [REDACTED]	45430	100471	DB5Z2078A	LEFT

Greg Hester  
DC Metropolitan Police Department  
Fleet Manager

[REDACTED]  
[REDACTED] cell

*"If I had asked people what they wanted, they would have said faster horses." — Henry Ford*

---

**From:** [REDACTED]  
**Sent:** Tuesday, April 29, 2014 8:59 AM  
**To:** [REDACTED]  
**Subject:** Brake hose

Greg,  
Here are the pictures on the most recent brake hose failure left front utility. We are saving the hose.

Thank You,  
Stephen Ferguson  
Operations Manager  
First Vehicle Services  
DC MPD

[REDACTED]  
[REDACTED]

**April is National Financial Capability Month!**

Evaluate your financial well-being with a [free personal financial health assessment](#) provided by the D.C. Dept. of Insurance, Securities and Banking.

[DISB.DC.gov](http://DISB.DC.gov)

---

**From:** [REDACTED]  
**Sent:** Thursday, November 07, 2013 3:24 PM  
**To:** [REDACTED]  
**Subject:** RE: (No Subject)

No to all the only thing I can say is it had track time prior to this test, will bring the parts home for root cause analysis we will owe them an answer ASAP

[REDACTED]  
Chassis Foundation  
Brake Engineering  
[REDACTED]

-----Original Message-----

**From:** [REDACTED]  
**Sent:** Thursday, November 07, 2013 03:18 PM Eastern Standard Time  
**To:** [REDACTED]  
**Subject:** RE: (No Subject)

Were the temps high or a different failure mode? Are the hoses typically replaced prior to an event?

[REDACTED]  
Brake Supervisor, V363, B299, D258, D385, D47X, U502, Econoline, C489  
FN3 – HS015  
[REDACTED]

---

**From:** [REDACTED]  
**Sent:** Thursday, November 07, 2013 3:04 PM  
**To:** [REDACTED]  
**Subject:** FW: (No Subject)

We just failed a brake hose on the utility during the cert, we are scrambling to find one to finish the event nod good news or press  
Ecoboost explorer

[REDACTED]  
Chassis Foundation  
Brake Engineering  
[REDACTED]





-----Original Message-----

**From:**

**To:** MacDonald, Thomas (J.)

**Subject:**



---

**From:** [REDACTED]  
**Sent:** Thursday, March 08, 2012 4:20 PM  
**To:** [REDACTED]  
**Subject:** RE: 502508-1 - Simulated Pomona on U502 (579W477) - New Jounce Prelim Data

Finally got the second sim Pomona test data with MCR hose, let me review and provide comparison, In my past discussions with Hitachi regarding heat exposure/aging effect here is what he provided.

[REDACTED]

---

**From:** [REDACTED]  
**Sent:** Thursday, March 08, 2012 7:15 AM  
**To:** [REDACTED]  
**Subject:** FW: 502508-1 - Simulated Pomona on U502 (579W477) - New Jounce Prelim Data

[REDACTED]  
*Chassis Brake Engineering  
Explorer, Taurus, MKS, MKT  
Ford Police Brake Platforms  
Product Development Center  
Cube 2CD47*

**ONE FORD**  
ONE TEAM • ONE PLAN • ONE GOAL

---

**From:** [REDACTED]  
**Sent:** Wednesday, March 07, 2012 2:22 PM  
**To:** [REDACTED]  
**Subject:** 502508-1 - Simulated Pomona on U502 (579W477) - New Jounce Prelim Data

Tom,

Attached is the prelim data for Sim Pomona test that included the new jounce hoses. The bottom right columns of data include max jounce block temp, max jounce hose temp and max bleed screw temp for both the left and right front corners. I also included temp profile graphs for each of the post fade cool downs w/ soaks.

Please review and let me know if there is anything you want me to change or update based on your needs.

Thank you,

[Redacted] Company  
[Redacted]

---

**From:** [REDACTED]  
**Sent:** Wednesday, August 27, 2014 11:30 AM  
**To:** [REDACTED]  
**Subject:** RE: Big Brakes  
**Attachments:** Re: U502 hose date

Hitachi started shipping new U502 hoses to the plant on 6/19/2012. There were no D-car hose changes around that time.

[REDACTED]

---

**From:** [REDACTED]  
**Sent:** Wednesday, August 27, 2014 8:49 AM  
**To:** [REDACTED]  
**Subject:** FW: Big Brakes

Below are the dates that big brake launched. Now need to determine when the MCR hose came into production at the plant.

Wendy, I am not sure if you were the tube and hose D&R at that time.

Thank You

[REDACTED]  
Brake Supervisor, V363, B299, D258, D385, D47X, U502, Econoline, C489  
FN3 – HS015  
[REDACTED]

---

**From:** [REDACTED]  
**Sent:** Tuesday, August 26, 2014 6:17 PM  
**To:** [REDACTED]  
**Subject:** RE: Big Brakes

Job2 do you mean 2012 and not 2014

---

**From:** [REDACTED]  
**Sent:** Tuesday, August 26, 2014 4:06 PM  
**To:** [REDACTED]  
**Subject:** RE: Big Brakes

[REDACTED]

2013 Job 1 = 2/6/2012

2013 Job 2 = 9/3/2014

Hope this helps!

[REDACTED]

---

**From:** [REDACTED]  
**Sent:** Tuesday, August 26, 2014 4:39 PM  
**To:** [REDACTED]  
**Subject:** Big Brakes

[REDACTED]

Can you confirm actual dates?

Heavy Duty Brakes – Police at 2013MY J1

Heavy Duty Brakes – Retail at 2013MY J2 (Base (with 18" tires), XLT, LTD, Sport)

[REDACTED]

---

**From:** [REDACTED]  
**Sent:** Wednesday, June 13, 2012 10:07 AM  
**To:** [REDACTED]  
**Cc:** [REDACTED]  
**Subject:** Re: U502 hose date

[REDACTED]

I confirmed with Pensacola that we will begin shipping the new level MCR hoses on June 18 and June 19.

Thank You,

[REDACTED]

[REDACTED]

[REDACTED]

[REDACTED]

06/11/2012 10:39 AM

To [REDACTED]  
cc  
Subject U502 hose date

Hi Tom,  
I heard the CMMS date for the new U502 hoses was July 17th. I thought we were pulling ahead to June 22nd? Please confirm the SOP date. The MCR trackers are on me. They want the change in for this quarter.

Thanks,  
[REDACTED]  
D Car Brake Systems Engineer  
[REDACTED]

---

**From:** [REDACTED]  
**Sent:** Wednesday, April 30, 2014 6:50 AM  
**To:** [REDACTED]  
**Subject:** RE: Brake hose (TOP-SECRET)

Fully agree. We will be walking this into hot topics.

[REDACTED]  
Brake Supervisor, V363, B299, D258, D385, D47X, U502, Econoline, C489  
FN3 – HS015  
3 [REDACTED]

---

**From:** [REDACTED]  
**Sent:** Tuesday, April 29, 2014 6:14 PM  
**To:** [REDACTED]  
**Subject:** FW: Brake hose (TOP-SECRET)

Classification: TOP-SECRET

Pete we need to get our hands around this one ASAP, I have asked for the latest failure to be returned to me but the ## is a little bothersome

Sent with Good ([www.good.com](http://www.good.com))

-----Original Message-----

**From:** [REDACTED]  
**Sent:** Tuesday, April 29, 2014 02:51 PM Eastern Standard Time  
**To:** [REDACTED]  
**Subject:** FW: Brake hose

Tom,  
Have you seen this before?

Best Regards,

---

[REDACTED]  
**Sent:** Tuesday, April 29, 2014 11:13 AM  
**To:** [REDACTED]

**Subject:** FW: Brake hose  
**Importance:** High

All,  
This is the 6<sup>th</sup> unit with a blown brake hose - vins are below for the others  
1FM5K8ARXDG [REDACTED] with 45,408 miles DC8218 DG [REDACTED] [REDACTED] [REDACTED] DB5 [REDACTED] LEFT

Here are the VINS and mileages of vehicles with brake hose problems.

TAG	VIN	MILEAGE	RO#	PART #	
DC8230	DGA [REDACTED]	26147	96998	DB5Z2078A	LEFT
DC8210	DG [REDACTED]	16511	97137	DB5Z2078B	RIGHT
DC8260	DG [REDACTED]	30872	98684	BB5Z2078B	RIGHT
DC8265	DG [REDACTED]	39369	98738	DB5Z2078A	LEFT
DC8226	DG [REDACTED]	33302	99997	DB5Z2078B	RIGHT
DC8218	DG [REDACTED]	45430	100471	DB5Z2078A	LEFT

Greg Hester  
DC Metropolitan Police Department  
Fleet Manager  
[REDACTED]  
[REDACTED] cell

*"If I had asked people what they wanted, they would have said faster horses." — Henry Ford*

---

**From:** [REDACTED]  
**Sent:** Tuesday, April 29, 2014 8:59 AM  
**To:** [REDACTED]  
**Subject:** Brake hose

Greg,  
Here are the pictures on the most recent brake hose failure left front utility. We are saving the hose.

Thank You,  
[REDACTED]  
Operations Manager  
First Vehicle Services  
DC MPD  
[REDACTED]@dc.gov

**April is National Financial Capability Month!**  
Evaluate your financial well-being with a [free personal financial health assessment](#) provided by the D.C. Dept. of Insurance, Securities and Banking.  
[DISB.DC.gov](http://DISB.DC.gov)

---

**From:** [REDACTED]  
**Sent:** Tuesday, April 29, 2014 4:00 PM  
**To:** [REDACTED]  
[REDACTED]  
**Subject:** Re: Brake hose

I will reach out to the Ford dealer and have any they replaced returned. Will Do the same for our shop.

---

**From:** [REDACTED]  
**Sent:** Tuesday, April 29, 2014 03:53 PM  
**To:** [REDACTED]  
[REDACTED]  
**Subject:** FW: Brake hose

Hi Greg

Is it possible to ship back any of the brake hoses? Our engineering team in Dearborn would like to evaluate them. I will need each hose identified with VIN.

Mailing address to send:

Ford Motor Company  
Attn: Thomas Daavettila

[REDACTED]  
Thanks

**LeeAnn Kirma**

PVT Police Quality Program Management  
Chicago Assembly Plant /Ford Police Programs

Cell: [REDACTED]  
[REDACTED]

---

**From:** [REDACTED]  
**Sent:** Tuesday, April 29, 2014 10:58 AM  
**To:** [REDACTED]  
**Subject:** FW: Brake hose  
**Importance:** High

[REDACTED]  
See Greg's Note below.



Thanks,

Jonathan Honeycutt  
North American Fleet, Lease and Remarketing Operations  
Fleet Brand Marketing Manager Car/CUV/SUV/Police

Office: [REDACTED]

---

**From:** [REDACTED]

**Sent:** Tuesday, April 29, 2014 11:13 AM

**To:** [REDACTED]

**Subject:** FW: Brake hose

**Importance:** High

All,  
This is the 6<sup>th</sup> unit with a blown brake hose - vins are below for the others  
1FM5K8ARXDG [REDACTED] with 45,408 miles DC8218 DG [REDACTED] 45430 100471 DB5Z2078A LEFT

Here are the VINS and mileages of vehicles with brake hose problems.

TAG	VIN	MILEAGE	RO#	PART #	
DC8230	DGA [REDACTED]	26147	96998	DB5Z2078A	LEFT
DC8210	DG [REDACTED]	16511	97137	DB5Z2078B	RIGHT
DC8260	DG [REDACTED]	30872	98684	BB5Z2078B	RIGHT
DC8265	DG [REDACTED]	39369	98738	DB5Z2078A	LEFT
DC8226	DG [REDACTED]	33302	99997	DB5Z2078B	RIGHT
DC8218	DG [REDACTED]	45430	100471	DB5Z2078A	LEFT

Greg Hester  
DC Metropolitan Police Department  
Fleet Manager

[REDACTED]  
[REDACTED] cell

*"If I had asked people what they wanted, they would have said faster horses." — Henry Ford*

---

**From:** [REDACTED]

**Sent:** Tuesday, April 29, 2014 8:59 AM

**To:** [REDACTED]

**Subject:** Brake hose

Greg,  
Here are the pictures on the most recent brake hose failure left front utility. We are saving the hose.

Thank You,  
[REDACTED]  
Operations Manager

First Vehicle Services  
DC MPD

[Redacted]  
[Redacted]  
[Redacted] Fax

Email: [Redacted]

**April is National Financial Capability Month!**

Evaluate your financial well-being with a [free personal financial health assessment](#) provided by the D.C. Dept. of Insurance, Securities and Banking.

[DISB.DC.gov](http://DISB.DC.gov)

---

**From:** [REDACTED]  
**Sent:** Thursday, June 05, 2014 10:25 AM  
**To:** [REDACTED]  
**Subject:** RE: Brake hose

[REDACTED]  
Any word/update on the Utility door panels— Geez we are getting crushed with the failures –of the panel separations, arm area cracking --

**Greg Hester**  
DC Metropolitan Police Department  
Fleet Manager  
[REDACTED] cell

*"If I had asked people what they wanted, they would have said faster horses." — Henry Ford*

---

**From:** [REDACTED] ]  
**Sent:** Thursday, June 05, 2014 10:21 AM  
**To:** [REDACTED]  
**Subject:** RE: Brake hose

Greg – Thank you!

Tom - Please let us know if you need further info

**LeeAnn Kirma**  
PVT Police Quality Program Management  
Chicago Assembly Plant /Ford Police Programs  
Cell: [REDACTED]  
[REDACTED]

---

**From:** [REDACTED]  
**Sent:** Thursday, June 05, 2014 7:53 AM  
**To:** [REDACTED]  
**Subject:** RE: Brake hose

Leeann,  
Here is what I can pull from the repair orders hope this helps –  
We are checking every vehicle now for the brake hose conditions

1FM5K8AR3DG [REDACTED] -- brake hose – 4-9-14 mi 33,302 (this was not warranty-per Ford dealer, hose was twisted by techs installing brake pads)  
1FM5K8AR5DG [REDACTED] —LF brake hose—12-17-13 mi 26,147— **Complaint was brakes low** -cause was LEFT FRONT BRAKE HOSE LEAKING  
1FM5K8AR0DG [REDACTED] —RF Brake hose --12-24-13 mi 16,511 - **Complaint was brakes was fading** —cause send To the dealer for right front brake hose leaking, lower radiator hose leaking. Correction dealer replaced rf hose and lower radiator hose  
1FM5K8AR1DG [REDACTED] -- RF brake hose --2-24-14- mi- 30,872 **Complaint : VEHICLE TOWED IN, BRAKES GO TO THE FLOOR** Cause: right brake hose leaking  
1FM5K8AR0DG [REDACTED] —LF brake hose-- 2-25-14 mi 39,369 **Complaint : tow in in- No start- Cause : found l/f brake hose leaking during safety inspection of the vehicle**  
1FM5K8ARXDG [REDACTED] - DC8218 DGA27064 Mi 45430 100471 DB5Z2078A LEFT hose 4-28-14  
**Complaint** : BRAKES ARE VERY LOW AND NEED TO BE REPLACED **Cause** : NEEDS A BRAKE HOSE....WFP. checked for no brake split in brake hose leaking . replaced  
1FM5K8ARXDG [REDACTED] - 5-14-14 miles 46,525 - same vehicle  
RF hose was replaced- on 5-14-14 Complaint: PM Service due- found bubble in hose during inspection – Cause PASSDOWN: RIGHT FRONT BRAKE HOSE HAS BUBBLE correction: send to dealer for r/f brake hose / P.T. U NOISE

**Greg Hester**  
**DC Metropolitan Police Department**  
**Fleet Manager**  
[REDACTED] office  
[REDACTED] cell

*"If I had asked people what they wanted, they would have said faster horses." — Henry Ford*

---

**From:** [REDACTED]  
**Sent:** Wednesday, June 04, 2014 10:01 AM  
**To:** [REDACTED]  
[REDACTED]  
**Subject:** RE: Brake hose

Thank you for sending in the brake hoses. Our team in Dearborn has been reviewing and evaluating the hoses the last couple of weeks.

Can you provide further information regarding the duty cycle, driving/roads conditions, at failure what was noticed/observed, etc? Any further info will help regarding the analysis.

**LeeAnn Kirma**  
PVT Police Quality Program Management  
Chicago Assembly Plant /Ford Police Programs  
Cell: [REDACTED]  
[REDACTED]

---

**From:** [REDACTED]  
**Sent:** Friday, May 02, 2014 11:28 AM  
**To:** [REDACTED]

[REDACTED]  
**Subject:** RE: Brake hose

Thank you!

Thomas Daavettila

Mobil: 3 [REDACTED]

---

**From:** [REDACTED]

**Sent:** Friday, May 02, 2014 10:53 AM

**To:** [REDACTED]

**Subject:** RE: Brake hose

**Delivered**

Tracking Number: 1Z9V3E750192655641

Service: UPS Next Day Air®

Weight: 4.00 lbs

Shipped/Billed On: 05/01/2014

Delivered On: 05/02/2014 9:54 A.M.

Delivered To: DEARBORN, MI, US

Signed By: HILL

Left At: Inside Delivery

Greg Hester

DC Metropolitan Police Department

Fleet Manager

[REDACTED] office

[REDACTED] cell

*"If I had asked people what they wanted, they would have said faster horses." — Henry Ford*

---

**From:** [REDACTED]

**Sent:** Friday, May 02, 2014 10:41 AM

**To:** [REDACTED]

**Subject:** RE: Brake hose

**Importance:** High

Greg- thank you

Thomas- Part are on their way. Tracking info below.

**LeeAnn Kirma**

PVT Police Quality Program Management

Chicago Assembly Plant /Ford Police Programs

Cell: [REDACTED]  
[REDACTED]

Friday, May 02, 2014 5:49 AM

**To:** [REDACTED]

**Subject:** RE: Brake hose

**Importance:** High

All-

These 2 vins make 7 units total for the brake hoses-

VIN'S-Date location & miles for brake hoses:

1FM5K8AR7DG [REDACTED] LF brake hose-- miles 34,194 4-23-14

1FM5K8ARXDG [REDACTED] LF brake hose--miles- 45,430 4-28-14

**UPS TRACKING # 1Z9V3E750192655641 OVERNIGHT to this address**

Ford Motor Company  
Attn: Thomas Daavettila

[REDACTED]

These- were replaced prior- parts were not called for by Ford warranty to review.  
Due to the date of repair these aren't available.

1FM5K8AR3DG [REDACTED] - brake hose - 4-9-14 mi 33,302 (this was not warranty-per Ford, hose was twisted by techs installing brake pads)

1FM5K8AR5DG [REDACTED] - LF brake hose - 12-17-13 mi 26,147

1FM5K8AR0DG [REDACTED] - RF Brake hose --12-24-13 mi 16,511

1FM5K8AR1DG [REDACTED] - RF brake hose --2-24-14- mi- 30,872

1FM5K8AR0DG [REDACTED] - LF brake hose-- 2-25-14 mi 39,369

Greg Hester  
DC Metropolitan Police Department  
Fleet Manager

[REDACTED]  
cell

*"If I had asked people what they wanted, they would have said faster horses." — Henry Ford*

**Sent:** Thursday, May 01, 2014 3:55 PM

**To:** [REDACTED]

**Subject:** RE: Brake hose

Thomas

Full VIN Numbers:

1FM5K8AR3DG [REDACTED]

1FM5K8AR5DG [REDACTED]

1FM5K8AR0DG [REDACTED]

1FM5K8ARXDG  
1FM5K8AR1DG  
1FM5K8AR0DG

**LeeAnn Kirma**

PVT Police Quality Program Management  
Chicago Assembly Plant /Ford Police Programs  
Cell: [REDACTED]

---

**From:** [REDACTED]  
**Sent:** Thursday, May 01, 2014 2:34 PM  
**To:** [REDACTED]  
**Subject:** RE: Brake hose

Greg,  
  
Would you be able to send me the full VIN numbers for the six vehicles?

Regards,  
[REDACTED]

---

**From:** [REDACTED]  
**Sent:** Wednesday, April 30, 2014 10:43 AM  
**To:** [REDACTED]  
**Subject:** RE: Brake hose

Copy  
  
**Greg Hester**  
DC Metropolitan Police Department  
Fleet Manager  
[REDACTED] office  
[REDACTED] cell

*"If I had asked people what they wanted, they would have said faster horses." — Henry Ford*

---

**From:** [REDACTED]  
**Sent:** Wednesday, April 30, 2014 10:42 AM  
**To:** [REDACTED]  
**Subject:** RE: Brake hose

Mailing address to send:

Ford Motor Company  
Attn: Thomas Daavettila

*Tom MacDonald  
Ford Police Programs  
Explorer, Taurus, MKS, MKT  
H-567 Heavy Truck and Transit  
Foundation Brake Engineering*



---

**From:** [REDACTED]

**Sent:** Wednesday, April 30, 2014 10:35 AM

**To:** [REDACTED]

**Subject:** RE: Brake hose

Tom,  
OK, Where do you want the old parts to go ?? Just need the location—so we can send -- Makes no difference to me  
LeeAnn asked for these to be shipped as below—  
Hey- maybe I can cut them in half and send each of you a section of the hose –LOL

Mailing address to send:

Ford Motor Company  
Attn: Thomas Daavettila

**From:** Kirma, LeeAnn (L.M.) [REDACTED]

**Sent:** [REDACTED]

**Subject:** FW: Brake hose

Hi Greg

Is it possible to ship back any of the brake hoses? Our engineering team in Dearborn would like to evaluate them. I will need each hose identified with VIN.

Mailing address to send:

Ford Motor Company  
Attn: Thomas Daavettila



Thanks

## LeeAnn Kirma

Greg Hester  
DC Metropolitan Police Department  
Fleet Manager

[REDACTED] office  
[REDACTED] cell

*"If I had asked people what they wanted, they would have said faster horses." — Henry Ford*

---

**From:** [REDACTED]  
**Sent:** Wednesday, April 30, 2014 7:21 AM  
**To:** [REDACTED]  
**Subject:** RE: Brake hose

I am in the middle of moving offices so if we can ship to Link Engineering that would be great, if possible can I get the hose overnight shipped please.

Ford Fedex account# 4586-9364-1  
[Link Engineering](#)

[REDACTED]

Attn: Tom MacDonald / Greg Shell

*Tom MacDonald  
Ford Police Programs  
Explorer, Taurus, MKS, MKT  
H-567 Heavy Truck and Transit  
Foundation Brake Engineering*

[REDACTED]



---

**From:** [REDACTED]  
**Sent:** Wednesday, April 30, 2014 1:16 AM  
**To:** [REDACTED]  
**Subject:** RE: Brake hose

Greg,

Would it be possible to get any of the parts for analysis?

Best Regards,

[REDACTED]  
Police/Ambulance/QVM, Supervisor  
PDC Bldg. / 1H-J21  
Phone: [REDACTED]

Share the Ford story at [www.TheFordStory.com](http://www.TheFordStory.com)

---

**From:** [REDACTED]

**Sent:** Tuesday, April 29, 2014 11:13 AM

**To:** [REDACTED]

**Subject:** FW: Brake hose

**Importance:** High

All,  
This is the 6<sup>th</sup> unit with a blown brake hose - vins are below for the others  
1FM5K8ARXDG [REDACTED] with 45,408 miles DC8218 DG [REDACTED] 45430 100471 DB5Z2078A LEFT

Here are the VINS and mileages of vehicles with brake hose problems.

TAG	VIN	MILEAGE	RO#	PART #	
DC8230	DGA [REDACTED]	26147	96998	DB5Z2078A	LEFT
DC8210	DG [REDACTED]	16511	97137	DB5Z2078B	RIGHT
DC8260	DG [REDACTED]	30872	98684	BB5Z2078B	RIGHT
DC8265	DG [REDACTED]	39369	98738	DB5Z2078A	LEFT
DC8226	DG [REDACTED]	33302	99997	DB5Z2078B	RIGHT
DC8218	DG [REDACTED]	45430	100471	DB5Z2078A	LEFT

Greg Hester  
DC Metropolitan Police Department  
Fleet Manager

[REDACTED]  
[REDACTED] cell

*"If I had asked people what they wanted, they would have said faster horses." — Henry Ford*

---

**From:** [REDACTED]

**Sent:** Tuesday, April 29, 2014 8:59 AM

**To:** [REDACTED]

**Subject:** Brake hose

Greg,  
Here are the pictures on the most recent brake hose failure left front utility. We are saving the hose.

Thank You,  
[REDACTED]  
Operations Manager  
First Vehicle Services

DC MPD



**April is National Financial Capability Month!**

Evaluate your financial well-being with a [free personal financial health assessment](#) provided by the D.C. Dept. of Insurance, Securities and Banking.

[DISB.DC.gov](http://DISB.DC.gov)

---

**From:** [REDACTED]  
**Sent:** Tuesday, August 19, 2014 8:34 AM  
**To:** [REDACTED]  
**Subject:** RE: Central labs report

We have some other parts coming that we would like to get an analysis of the braid material. If there is a way to expedite the test and report I would like to do that to support the discussions.

[REDACTED]  
Brake Supervisor, V363, B299, D258, D385, D47X, U502, Econoline, C489  
FN3 – HS015  
313-805-4797

---

**From:** [REDACTED]  
**Sent:** Monday, August 18, 2014 11:25 AM  
**To:** [REDACTED]  
**Subject:** RE: Central labs report

The Lab request was submitted on Aug. 12 for IR, TGA, and DSC analysis with a completion date of Sept. 12. I've just returned from vacation and have not been able to determine if preliminary results were scheduled to be available for an Aug. 19 meeting.

*Regards,*

[REDACTED]  
Materials Engineering and Standards  
[REDACTED]

---

**From:** [REDACTED]  
**Sent:** Monday, August 18, 2014 11:03 AM  
**To:** [REDACTED]  
**Subject:** RE: Central labs report

Yes it is required to support a NHSTA report out tomorrow.

[REDACTED]  
Brake Supervisor, V363, B299, D258, D385, D47X, U502, Econoline, C489

FN3 – HS015  
[REDACTED]

---

**Sent:** Monday, August 18, 2014 10:56 AM  
**To:** [REDACTED]  
**Subject:** RE: Central labs report

Andy said he'll look into it. I told him I'll call back this afternoon because we need to the report asap.

*Christine Vandeyar*

Brake Engineer, PD  
[REDACTED]

---

**From:** [REDACTED]  
**Sent:** Monday, August 18, 2014 10:55 AM  
**To:** [REDACTED]  
**Subject:** Central labs report

[REDACTED]

Have you received the report from central labs yet on the rubber analysis?

Thank You

[REDACTED]  
Brake Supervisor, V363, B299, D258, D385, D47X, U502, Econoline, C489  
FN3 – HS015  
[REDACTED]

---

**From:** [REDACTED]  
**Sent:** Tuesday, May 06, 2014 12:49 PM  
**To:** [REDACTED]  
**Subject:** RE: Explorer Police Unit

I need to take my parts off before we do this, so give me a day to do so, then it will be ready. So plan for Thursday please.

*Tom MacDonald  
Ford Police Programs  
Explorer, Taurus, MKS, MKT  
H-567 Heavy Truck and Transit  
Foundation Brake Engineering*



---

**From:** [REDACTED]  
**Sent:** Tuesday, May 06, 2014 12:03 PM  
**To:** [REDACTED]  
**Subject:** Explorer Police Unit



I am looking to see if that police explorer unit would be available to do a full jounce study on, we would need to remove the wheel and the spring so that a complete jounce study could be done. If this vehicle is not available do we have another police unit? Also, I believe we could run the test at Hitachi if Link is too busy.

Regards,  
**Thomas Daavettila**  
Ford Motor Company  
Brake Engineer  
Mobil: 313-348-6355  
Desk: FN3 HM-015

---

**From:** [REDACTED]  
**Sent:** Monday, August 11, 2014 12:27 PM  
**To:** [REDACTED]  
**Subject:** RE: Jounce hose to central labs

Sorry hit send before I was ready.

Do you know if Hitachi got the rest of the parts from the DC police? Have they reviewed any of them?

Thank You

[REDACTED]  
Brake Supervisor, V363, B299, D258, D385, D47X, U502, Econoline, C489  
FN3 – HS015  
[REDACTED]

---

**From:** [REDACTED]  
**Sent:** Monday, August 11, 2014 12:20 PM  
**To:** [REDACTED]  
**Subject:** RE: Jounce hose to central labs

[REDACTED]  
The hose is with central labs. The testing on the hose should be complete today.

Regards,  
Thomas Daavettila  
Mobil: [REDACTED]

---

**From:** [REDACTED]  
**Sent:** Monday, August 11, 2014 12:14 PM  
**To:** [REDACTED]  
**Subject:** Jounce hose to central labs

Has the hose been delivered to central labs yet for analysis? Need to keep this moving so we can provide updates. I am starting to get allot of phone calls.

Thank You

[REDACTED]  
Brake Supervisor, V363, B299, D258, D385, D47X, U502, Econoline, C489  
FN3 – HS015  
313-805-4797

---

**From:** [REDACTED]  
**Sent:** Thursday, May 01, 2014 7:37 AM  
**To:** [REDACTED]  
**Subject:** RE: Police Explorer.

Sorry I got tied with the Voice of the Customer transit fleet yesterday afternoon so I could not assist Tom on this one. Bill to my PO.

Thanks for helping Tom out, let me know if you need anything else.

Please do not remove the front calipers for any reason without my knowledge the parts on this vehicle are being evaluated for NVH foxes for Police.

Let me know when you are completed.

*Tom MacDonald  
Ford Police Programs  
Explorer, Taurus, MKS, MKT  
H-567 Heavy Truck and Transit  
Foundation Brake Engineering*



---

**From:** [REDACTED]  
**Sent:** Wednesday, April 30, 2014 2:20 PM  
**To:** [REDACTED]  
**Subject:** RE: Police Explorer.

Tom,

Good afternoon. I've attached the paperwork needed on our end to get this going. I'll have to hand this off to Don Kujat (the interim Greg Shell) and let him respond with that time will work for the shop tomorrow. Is the vehicle already here?

Regards,

**Brian Nycek**  
Link Engineering Company

---

**From:** [REDACTED]  
**Sent:** Wednesday, April 30, 2014 1:54 PM  
**To:** [REDACTED]



**Cc:** [REDACTED]  
**Subject:** FW: Police Explorer.

Greg, Brian,

Could one of you help me with the request below since Greg is out of the office?

Regards,

Mobil: [REDACTED]

---

**From:** [REDACTED]  
**Sent:** Wednesday, April 30, 2014 1:51 PM  
**To:** 'Greg Shell'  
**Cc:** [REDACTED]  
**Subject:** RE: Police Explorer.

Greg,

I would like to set up a Front brake hose hoist review on the Explorer 567W297 for tomorrow. What we are looking to do is, get the vehicle in the Air and then review the front brake hoses, No tear apart of the vehicle expected except for removing the front wheels. Could you let me know if it is possible, and what time we could set up the review tomorrow?

Regards,

Thomas Daavettila

Mobil: [REDACTED]

---

**From:** [REDACTED]  
**Sent:** Monday, April 28, 2014 2:09 PM  
**To:** [REDACTED]  
**Subject:** RE: Police Explorer.

Tom  
Sounds good

**Greg Shell**  
**Link Engineering Company**

---

**From:** [REDACTED]  
**Sent:** Monday, April 28, 2014 1:57 PM  
**To:** [REDACTED]  
**Subject:** Police Explorer.

Greg,  
Tom is going to pick up the Explorer this afternoon 567W297 to evaluate for me.

*Ford Police Programs  
Explorer, Taurus, MKS, MKT  
H-567 Heavy Truck and Transit  
Foundation Brake Engineering*



---

**From:** [REDACTED]  
**Sent:** Thursday, August 25, 2011 8:49 AM  
**To:** [REDACTED]  
**Subject:** Re: Ship date for inner ply change to CSAP

Not yet, I will check to see if the trial hose has been delivered to my distribution center. It shouldn't take long to get the parts once I have the hose.

George McKinney  
Program Manager  
Hitachi Cable Indiana  
34500 Grand River Ave  
[REDACTED]  
[REDACTED]

[REDACTED]  
08/25/2011 08:38 AM

To [REDACTED] >  
cc  
Subject Ship date for inner ply change to CSAP

George,  
Has Hitachi started shipping the inner ply change for hoses going to Cuautitlan? What day did they start shipping?

CSAP wanted to perform a quick trial before using for production.

Thanks,  
[REDACTED]  
[REDACTED]  
[REDACTED]

---

**From:** [REDACTED]  
**Sent:** Wednesday, June 13, 2012 10:07 AM  
**To:** [REDACTED]  
**Subject:** Re: U502 hose date

[REDACTED]

I confirmed with Pensacola that we will begin shipping the new level MCR hoses on June 18 and June 19.

Thank You,

[REDACTED]

[REDACTED]

[REDACTED]

Phone: [REDACTED]

[REDACTED]

[REDACTED] >

06/11/2012 10:39 AM

To [REDACTED] >

cc

Subject U502 hose date

[REDACTED]

I heard the CMMS date for the new U502 hoses was July 17th. I thought we were pulling ahead to June 22nd? Please confirm the SOP date. The MCR trackers are on me. They want the change in for this quarter.

[REDACTED]

[REDACTED]

[REDACTED]

[REDACTED]

---

**From:** [REDACTED]  
**Sent:** Friday, January 20, 2012 9:27 AM  
**To:** [REDACTED]  
**Cc:** [REDACTED]  
**Subject:** Re: U502 Jounce

[REDACTED]

We have a solution for Big Brake package that uses the old banjo tube and can be implemented relatively quickly. This would not work on the Small Brake package, however. We are trying to develop a design common for both, but this would most likely involve a longer lead-time banjo change.

The most likely outcome is that we would have to ship unique Big and Small brake parts to ZF Lemforder until the MCR design can be validated on the Big brakes.

Thank You,

[REDACTED]

Hitachi Cable Florida  
[REDACTED]  
[REDACTED]

[REDACTED]

01/19/2012 09:54 PM

[REDACTED]

[REDACTED]

Subject U502 Jounce

Where are we at with the U502 Jounce Study, what are we going to do?

Regards,  
[REDACTED]

---

**From:** [REDACTED]  
**Sent:** Tuesday, August 26, 2014 6:39 PM  
**To:** [REDACTED]  
**Cc:** [REDACTED]  
**Subject:** U502 Interceptor Brake Hose Failures

Hi J.L.,

I ran into a piece of news on internet today (see the link below). It seems there is an on-going investigation by Ford and now the government agency involving U502 police car. I don't know if you're aware of but I couldn't find any e-mail in my inbox on the subject. Anyway, I talked to Hitachi folks and here is a summary:

- All failures are from U502 police Interceptor, 18" brake disk.
- Majority of failures are from DC police department, very few from Wisconsin.
- Failure occurred about half an inch away from crimp on the same spot.
- About 30 – 50 failures so far. Hitachi has four (4) on hand.
- All failures are from March – June 2012 build dates.
- Crimps are ok.
- Hitachi Indiana office leads the investigation.
- There is daily meeting going on between Ford and Hitachi.
- Simulation by Hitachi was able to recreate the failure but 180 degree opposite from the failures from the field. The simulation was performed by up and down motion.
- Further tests by simulating steering wheel turns are being conducted.
- Rubber hoses are from Hitachi's sister plant in Thailand.
- Tests will be completed by end of this week.

Steve, Buche & Christine, Please add or correct.

<https://finance.yahoo.com/news/us-probes-ford-explorer-police-122504162.html>

Thank you.

[REDACTED]

**From:** [REDACTED]  
**Sent:** Wednesday, August 20, 2014 2:07 PM  
**To:** [REDACTED]  
**Subject:** warranty data by build month

This is the info I got from ASO in their warranty review. Since the DC cars were not repaired at a dealer they are not included in this data and they were all built in March 2012. I still need to confirm as the spreadsheet did not contain full VINS to make sure no double counting is happening. But interesting trend.

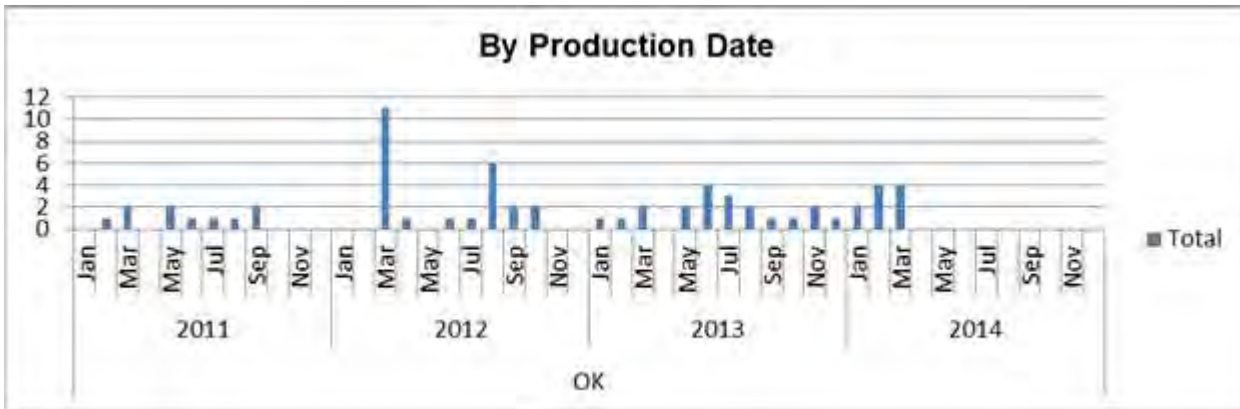

[REDACTED]  
Brake Supervisor, V363, B299, D258, D385, D47X, U502, Econoline, C489  
FN3 – HS015  
313-805-4797



LASD Simulated Pomona Police Vehicle Evaluation Test  
1st 8 Lap Cycle

Link Section: 100 -- Fade #1 (new hose)

Stop #	INITIAL SPEED	ACTUAL MEAS DIST	MAXIMUM PEDAL FORCE	AVERAGE PEDAL FORCE	MAXIMUM DECEL	AVERAGE DECEL	MAXIMUM PEDAL TRAVEL	AVERAGE PEDAL TRAVEL	
#	AT APPLY	FINAL SPEED							
1	115.4 mph	31.3 mph	690.7 ft	33.6 lb	23.1 lb	0.93 g	0.67 g	2.6 in	2.1 in
2	106.1 mph	27.1 mph	626.4 ft	28.9 lb	16.7 lb	0.78 g	0.61 g	2.5 in	2.1 in
3	80.3 mph	29.8 mph	298.3 ft	24.9 lb	19.2 lb	0.82 g	0.66 g	2.5 in	2.2 in
4	112.7 mph	31.9 mph	521.0 ft	99.6 lb	51.4 lb	0.92 g	0.78 g	3.2 in	2.8 in
5	104.5 mph	29.3 mph	524.0 ft	33.1 lb	24.2 lb	0.76 g	0.67 g	2.8 in	2.6 in
6	79.1 mph	28.0 mph	315.1 ft	38.4 lb	25.1 lb	0.78 g	0.62 g	3.1 in	2.5 in
7	107.4 mph	31.7 mph	473.3 ft	125.9 lb	84.1 lb	0.89 g	0.78 g	3.7 in	3.3 in
8	105.2 mph	30.4 mph	481.7 ft	53.6 lb	29.9 lb	0.81 g	0.73 g	3.3 in	3.0 in
9	84.3 mph	46.9 mph	237.7 ft	36.7 lb	26.7 lb	0.85 g	0.71 g	3.1 in	2.8 in
10	111.0 mph	28.3 mph	497.2 ft	111.9 lb	83.2 lb	0.99 g	0.82 g	3.7 in	3.4 in
11	104.3 mph	31.8 mph	507.9 ft	40.8 lb	22.9 lb	0.84 g	0.67 g	3.1 in	2.7 in
12	86.2 mph	35.3 mph	308.3 ft	37.4 lb	26.2 lb	0.82 g	0.69 g	2.9 in	2.7 in
13	109.8 mph	27.2 mph	511.5 ft	143.0 lb	106.5 lb	1.02 g	0.80 g	3.9 in	3.5 in
14	104.7 mph	29.4 mph	478.6 ft	61.4 lb	40.1 lb	0.86 g	0.74 g	3.3 in	3.1 in
15	85.0 mph	35.9 mph	284.9 ft	48.3 lb	35.1 lb	0.86 g	0.72 g	3.1 in	2.9 in
16	108.6 mph	29.3 mph	495.6 ft	162.9 lb	127.2 lb	0.97 g	0.78 g	3.8 in	3.5 in
17	104.7 mph	31.1 mph	474.2 ft	103.4 lb	68.2 lb	0.84 g	0.73 g	3.6 in	3.3 in
18	84.9 mph	27.6 mph	308.9 ft	54.4 lb	34.9 lb	0.85 g	0.72 g	3.2 in	2.9 in
19	110.5 mph	31.0 mph	539.1 ft	186.5 lb	160.4 lb	0.86 g	0.72 g	4.0 in	3.7 in
20	108.7 mph	29.6 mph	562.5 ft	152.4 lb	107.6 lb	0.80 g	0.68 g	4.0 in	3.7 in
21	104.2 mph	37.7 mph	517.7 ft	55.4 lb	41.1 lb	0.75 g	0.64 g	3.6 in	3.2 in
22	106.8 mph	29.0 mph	546.5 ft	159.1 lb	122.2 lb	0.79 g	0.68 g	4.0 in	3.7 in
23	104.4 mph	30.2 mph	545.9 ft	145.4 lb	92.2 lb	0.80 g	0.65 g	4.1 in	3.7 in
24	85.5 mph	28.6 mph	336.8 ft	125.5 lb	70.5 lb	0.85 g	0.68 g	3.9 in	3.4 in

Stop #	MAX LF OUTER PAD TEMP	MAX RF OUTER PAD TEMP	MAX LR OUTER PAD TEMP	MAX RR OUTER PAD TEMP	MAX LF BLOCK TEMP	MAX RF BLOCK TEMP	MAX LF HOSE TEMP	MAX RF HOSE TEMP	MAX LF BLEEDER TEMP	MAX RF BLEEDER TEMP
1	410 °F	420 °F	487 °F	530 °F	69 °F	68 °F	64 °F	64 °F	75 °F	73 °F
2	538 °F	522 °F	610 °F	633 °F	73 °F	74 °F	68 °F	66 °F	76 °F	74 °F
3	541 °F	555 °F	535 °F	584 °F	75 °F	79 °F	70 °F	67 °F	77 °F	75 °F
4	741 °F	725 °F	702 °F	773 °F	76 °F	84 °F	72 °F	69 °F	79 °F	77 °F
5	864 °F	829 °F	787 °F	801 °F	79 °F	85 °F	73 °F	71 °F	82 °F	80 °F
6	828 °F	795 °F	806 °F	800 °F	82 °F	89 °F	75 °F	72 °F	86 °F	85 °F
7	969 °F	914 °F	934 °F	918 °F	83 °F	92 °F	75 °F	73 °F	91 °F	89 °F
8	1067 °F	1009 °F	1016 °F	1036 °F	82 °F	90 °F	72 °F	72 °F	96 °F	95 °F
9	1009 °F	971 °F	987 °F	1001 °F	86 °F	92 °F	75 °F	73 °F	101 °F	100 °F
10	1187 °F	1117 °F	1088 °F	1087 °F	92 °F	96 °F	77 °F	72 °F	108 °F	107 °F
11	1244 °F	1211 °F	1150 °F	1161 °F	95 °F	102 °F	81 °F	75 °F	116 °F	114 °F
12	1218 °F	1201 °F	1152 °F	1145 °F	96 °F	109 °F	79 °F	77 °F	124 °F	121 °F
13	1364 °F	1317 °F	1213 °F	1201 °F	102 °F	110 °F	82 °F	76 °F	132 °F	129 °F
14	1420 °F	1347 °F	1222 °F	1216 °F	104 °F	108 °F	81 °F	76 °F	140 °F	136 °F
15	1366 °F	1316 °F	1178 °F	1180 °F	105 °F	111 °F	79 °F	75 °F	147 °F	143 °F
16	1463 °F	1445 °F	1209 °F	1231 °F	102 °F	112 °F	76 °F	75 °F	153 °F	151 °F
17	1488 °F	1466 °F	1196 °F	1229 °F	110 °F	113 °F	80 °F	76 °F	160 °F	158 °F
18	1450 °F	1438 °F	1151 °F	1184 °F	114 °F	123 °F	82 °F	77 °F	169 °F	167 °F
19	1552 °F	1526 °F	1197 °F	1231 °F	118 °F	129 °F	84 °F	81 °F	178 °F	176 °F
20	1606 °F	1584 °F	1225 °F	1246 °F	118 °F	128 °F	82 °F	77 °F	185 °F	183 °F
21	1618 °F	1585 °F	1212 °F	1231 °F	126 °F	134 °F	86 °F	81 °F	194 °F	192 °F
22	1643 °F	1637 °F	1241 °F	1246 °F	126 °F	139 °F	84 °F	84 °F	201 °F	199 °F
23	1631 °F	1622 °F	1249 °F	1261 °F	125 °F	137 °F	81 °F	79 °F	207 °F	206 °F
24	1574 °F	1559 °F	1206 °F	1226 °F	126 °F	141 °F	81 °F	83 °F	213 °F	215 °F
	<b>Maximum:</b>				126 °F	141 °F	86 °F	84 °F	213 °F	215 °F
	<b>Average:</b>				99 °F	106 °F	77 °F	75 °F	133 °F	131 °F

Notes:  
All averages calculated from initial apply to unapply  
Apply is the point in time when the pedal force is greater than 3 (lb)  
Ambient temperature during the section was 56 °F



## Post Fade 1: Cool Down & Soak Temperature Curves

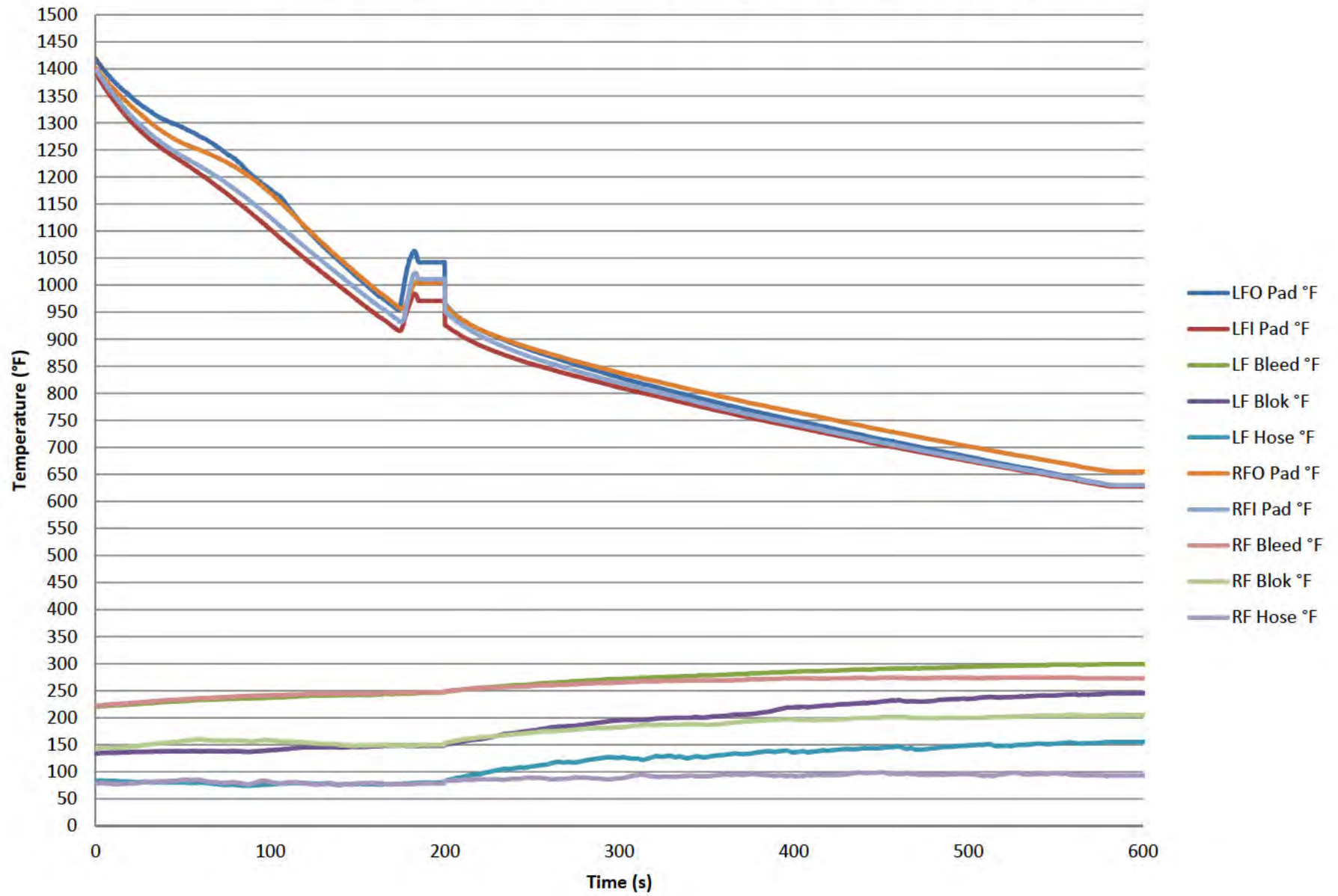

Test procedure: Simulated Pomona Testing (New Jounce)  
 Test number: 502508  
 Front lining: PFC 49  
 Rear lining: PFC 42

Vehicle #: 579W477  
 Vehicle Description: 2013 Ford  
 Vehicle Model: Explorer Police AWD  
 Platform: U502



Testing date: 03/07/2012  
 Printed date: 3/07/2012

LASD Simulated Pomona Police Vehicle Evaluation Test  
 2nd 8 Lap Cycle

Link Section: 200 – Fade #2 (new hose)

Stop #	INITIAL SPEED		ACTUAL MEAS DIST	MAXIMUM PEDAL FORCE	AVERAGE PEDAL FORCE	MAXIMUM DECEL	AVERAGE DECEL	MAXIMUM PEDAL TRAVEL	AVERAGE PEDAL TRAVEL
	AT APPLY	FINAL SPEED							
1	115.9 mph	30.8 mph	539.9 ft	95.1 lb	62.8 lb	1.00 g	0.83 g	3.7 in	3.4 in
2	104.2 mph	32.1 mph	492.7 ft	41.2 lb	23.2 lb	0.82 g	0.70 g	3.0 in	2.7 in
3	85.5 mph	31.4 mph	312.8 ft	32.6 lb	22.7 lb	0.83 g	0.71 g	2.8 in	2.6 in
4	113.4 mph	29.0 mph	543.4 ft	112.4 lb	77.1 lb	0.99 g	0.78 g	3.5 in	3.2 in
5	103.6 mph	31.9 mph	477.2 ft	68.6 lb	41.8 lb	0.87 g	0.71 g	3.3 in	3.1 in
6	85.3 mph	32.0 mph	299.6 ft	50.4 lb	36.8 lb	0.86 g	0.73 g	3.2 in	3.0 in
7	109.3 mph	25.8 mph	524.7 ft	175.4 lb	141.8 lb	1.02 g	0.78 g	4.0 in	3.6 in
8	106.7 mph	27.2 mph	515.3 ft	124.6 lb	79.0 lb	0.92 g	0.73 g	3.7 in	3.4 in
9	86.0 mph	29.8 mph	317.7 ft	101.2 lb	64.4 lb	0.89 g	0.72 g	3.7 in	3.4 in
10	111.3 mph	26.8 mph	580.2 ft	244.8 lb	155.8 lb	0.93 g	0.73 g	4.3 in	3.8 in
11	103.7 mph	32.1 mph	492.2 ft	126.8 lb	86.8 lb	0.84 g	0.70 g	3.8 in	3.5 in
12	85.4 mph	26.5 mph	320.0 ft	109.3 lb	81.5 lb	0.89 g	0.72 g	3.8 in	3.6 in
13	108.9 mph	31.3 mph	560.0 ft	173.5 lb	133.3 lb	0.86 g	0.69 g	4.2 in	3.8 in
14	105.4 mph	34.8 mph	541.2 ft	136.9 lb	98.9 lb	0.79 g	0.65 g	4.1 in	3.7 in
15	84.8 mph	30.9 mph	319.9 ft	98.9 lb	70.7 lb	0.83 g	0.68 g	4.0 in	3.6 in
16	107.9 mph	29.5 mph	555.5 ft	181.6 lb	160.1 lb	0.83 g	0.68 g	4.5 in	4.1 in
17	105.1 mph	28.8 mph	565.0 ft	170.9 lb	122.6 lb	0.80 g	0.64 g	4.4 in	4.0 in
18	85.9 mph	32.2 mph	327.4 ft	142.8 lb	111.7 lb	0.81 g	0.67 g	4.5 in	4.1 in
19	111.6 mph	30.6 mph	627.7 ft	176.6 lb	148.1 lb	0.80 g	0.65 g	4.8 in	4.3 in
20	108.6 mph	27.0 mph	614.0 ft	155.1 lb	131.0 lb	0.81 g	0.63 g	4.8 in	4.3 in
21	82.8 mph	34.7 mph	297.5 ft	116.5 lb	87.8 lb	0.77 g	0.66 g	4.4 in	3.9 in
22	110.5 mph	33.9 mph	628.2 ft	159.8 lb	116.9 lb	0.77 g	0.63 g	4.7 in	4.1 in
23	105.3 mph	26.0 mph	555.5 ft	177.7 lb	152.5 lb	0.82 g	0.66 g	4.8 in	4.4 in
24	85.6 mph	30.1 mph	323.4 ft	159.0 lb	135.9 lb	0.82 g	0.69 g	4.6 in	4.2 in

Stop #	MAX LF OUTER PAD TEMP		MAX RF OUTER PAD TEMP		MAX LF BLOCK TEMP	MAX RF BLOCK TEMP	MAX LF HOSE TEMP	MAX RF HOSE TEMP	MAX LF BLEEDER TEMP	MAX RF BLEEDER TEMP
	LF OUTER PAD TEMP	RF OUTER PAD TEMP	LR OUTER PAD TEMP	RR OUTER PAD TEMP						
1	983 °F	1056 °F	621 °F	654 °F	180 °F	158 °F	90 °F	76 °F	277 °F	254 °F
2	983 °F	1023 °F	666 °F	707 °F	173 °F	147 °F	90 °F	76 °F	267 °F	243 °F
3	967 °F	1001 °F	671 °F	698 °F	168 °F	150 °F	91 °F	80 °F	260 °F	236 °F
4	1210 °F	1243 °F	825 °F	838 °F	159 °F	147 °F	90 °F	77 °F	253 °F	229 °F
5	1238 °F	1256 °F	832 °F	843 °F	155 °F	141 °F	90 °F	78 °F	245 °F	221 °F
6	1177 °F	1201 °F	809 °F	811 °F	152 °F	141 °F	90 °F	79 °F	240 °F	217 °F
7	1348 °F	1359 °F	918 °F	911 °F	146 °F	134 °F	87 °F	77 °F	233 °F	211 °F
8	1386 °F	1404 °F	989 °F	989 °F	135 °F	128 °F	82 °F	77 °F	227 °F	207 °F
9	1319 °F	1346 °F	955 °F	950 °F	137 °F	130 °F	85 °F	78 °F	223 °F	205 °F
10	1462 °F	1493 °F	1048 °F	1048 °F	138 °F	133 °F	87 °F	78 °F	222 °F	205 °F
11	1478 °F	1507 °F	1077 °F	1064 °F	140 °F	132 °F	91 °F	79 °F	223 °F	206 °F
12	1437 °F	1482 °F	1057 °F	1033 °F	138 °F	140 °F	89 °F	81 °F	224 °F	209 °F
13	1545 °F	1605 °F	1142 °F	1110 °F	139 °F	141 °F	90 °F	84 °F	225 °F	211 °F
14	1576 °F	1622 °F	1175 °F	1134 °F	141 °F	137 °F	89 °F	80 °F	227 °F	212 °F
15	1505 °F	1560 °F	1124 °F	1090 °F	140 °F	137 °F	88 °F	79 °F	228 °F	213 °F
16	1596 °F	1653 °F	1179 °F	1163 °F	131 °F	133 °F	83 °F	79 °F	227 °F	215 °F
17	1628 °F	1683 °F	1210 °F	1200 °F	136 °F	137 °F	86 °F	81 °F	228 °F	218 °F
18	1562 °F	1602 °F	1152 °F	1153 °F	139 °F	139 °F	87 °F	78 °F	232 °F	223 °F
19	1661 °F	1687 °F	1240 °F	1239 °F	140 °F	142 °F	91 °F	83 °F	235 °F	225 °F
20	1691 °F	1708 °F	1293 °F	1283 °F	141 °F	145 °F	90 °F	82 °F	238 °F	229 °F
21	1601 °F	1609 °F	1222 °F	1219 °F	145 °F	150 °F	92 °F	85 °F	242 °F	233 °F
22	1639 °F	1662 °F	1252 °F	1244 °F	146 °F	146 °F	90 °F	84 °F	244 °F	235 °F
23	1635 °F	1682 °F	1275 °F	1263 °F	140 °F	142 °F	85 °F	82 °F	244 °F	237 °F
24	1583 °F	1614 °F	1213 °F	1212 °F	139 °F	146 °F	86 °F	83 °F	245 °F	241 °F
<b>Maximum:</b>					<b>180 °F</b>	<b>158 °F</b>	<b>92 °F</b>	<b>85 °F</b>	<b>277 °F</b>	<b>254 °F</b>
<b>Average:</b>					<b>146 °F</b>	<b>141 °F</b>	<b>88 °F</b>	<b>80 °F</b>	<b>238 °F</b>	<b>222 °F</b>

Notes:  
 All averages calculated from initial apply to unapply  
 Apply is the point in time when the pedal force is greater than 3 (lb)  
 Ambient temperature during the section was 58 °F

## Post Fade 2: Cool Down & Soak Temperature Curves

