

**Customer Assistance Inquiry Record (CAIR)#** [REDACTED]

<b>VIN</b>	3B7HC12Y2	WM [REDACTED]	<b>Open Date</b>	01/13/1998	<b>Built Date</b>	09/23/1997
<b>Model Year</b>	1998	<b>Body</b>	BE1L31	DODGE RAM 1500 P/U CLUB CAB		
<b>In Service Dt</b>	12/14/1997	<b>Mileage</b>	440	<b>Dealer Zone</b>	61	ATLANTA
<b>Plant</b>	M	MEXICO CITY ASSEMBLY PLANT	<b>Market</b>	U	US	
<b>Dealer</b>	65074	HAYES CHRY-DODGE-JEEP INC				
<b>Dealer Address</b>	719 W PIKE STREET					
<b>Dealer City</b>	LAWRENCEVILLE	<b>Dealer State</b>	GA	<b>Dealer Zip</b>	30045	
<b>Owner</b>	[REDACTED]	<b>Contact Type</b>	TELEPHONE			
<b>Address</b>	[REDACTED]	<b>Home Phone</b>	[REDACTED]			
	SUWANEE GA [REDACTED]	<b>Country</b>	UNITED STATES			

Product - Clutch - Unknown - Binds, Sticks, Seized - Default	Clutch safety switch.
--	-----------------------

Owner states that truck keeps breaking down and being towed to dealer.  
 Owner states that clutch safety switch keeps failing and that every time it gets fixed the truck breaks down again. Owner states that dlr doesn't know what to do.  
 Left message/ext with SM Harrold. I will document his concern and advise that I will address issue further when Harrold calls back.  
 Harrold left message stating he will not be available until morning. I will call back then.  
 Called Harrold left message/ext.  
 Second clutch switch installed last week. Harrold states that owner hasn't called back with further concerns.  
 SM states switch was replace twice- last time 1-7-98.  
 SM states that he will call owner to see if he is still having problems with vehicle. SM has my ext so will call if necessary.  
 2/3/98 Owner calls back with same concern. Owner stated that he has contacted selling dealer to ask them to take vehicle back. Writer contacted Harold(SM) who stated that selling dealer installed an after market starter kill type device that is failing(security device). Harold stated that he traced the wires back and found that the failure is in the after market starter. Harold has left a message for his DM regarding this situation.  
 Harold will take the ignition device off of the truck with the owner's permission, but the owner stated that he will not pick up the truck. Writer advised owner that he would need to contact selling dealer to take this matter up with them and provided him with the name of the dealer principle.  
 Writer suggested owner pick up vehicle from servicing dealer because they are not involved in this situation and if he abandons vehicle on their lot they could charge him a storage charge. stm3

**Customer Assistance Inquiry Record (CAIR)#** [REDACTED]

<b>VIN</b>	3B7MF366X XM [REDACTED]	<b>Open Date</b>	06/22/1999	<b>Built Date</b>	01/12/1999
<b>Model Year</b>	1999	<b>Body</b>	BR8L62	DODGE RAM 3500 PICKUP	
<b>In Service Dt</b>	05/26/1999	<b>Mileage</b>	2,000	<b>Dealer Zone</b>	64 MEMPHIS
<b>Plant</b>	M	MEXICO CITY ASSEMBLY PLANT	<b>Market</b>	U	US
<b>Color</b>	PW7	BRIGHT WHITE CLEAR COAT			
<b>Engine</b>	ETC	5.9L I6 CUMMINS 24V DIESEL ENGINE			
<b>Transmission</b>	DDX	5-SPEED HD MANUAL TRANSMISSION			
<b>Dealer</b>	43561	DAVIS MOTOR COMPANY			
<b>Dealer Address</b>	209 INGRAM				
<b>Dealer City</b>	CLINTON	<b>Dealer State</b>	AR	<b>Dealer Zip</b>	72031
<b>Owner</b>	[REDACTED]	<b>Contact Type</b>	TELEPHONE		
<b>Address</b>	[REDACTED]	<b>Home Phone</b>			
	CLINTON AR [REDACTED]	<b>Country</b>	UNITED STATES		

Product - Unknown - Unknown - Accident - Default	Customer states vehicle started and accelerated without clutch engaged.
--	---

6/22/99 Request inspection of vehicle . Customer states the 3500 truck he recently purchased, Manual Trans, started and accelerated when he turned the ignition to use the radio. Customer stated that he was out of the vehicle reached in turned the key without the clutch engaged and the truck moved forward and hit a shop window.  
vehicle is located at DAVIS MOTOR COMPANY 209 INGRAM ST. CLINTON AR.  
PHONE [REDACTED] CONTACT PERSONS L.J. DAVIS OR DEAN MCKINNEY  
6/22/99-Pls inspect...photos, police report, pvir, area of concern park brake/throttle components/ignition and any other info...Return report to Art Gilbert  
CAIR NUMBER [REDACTED] REQUEST EAA INSPECTION 06-22-1999 11:38  
CAIR NUMBER [REDACTED] 7 FAX SENT TO EAA 06-22-1999 11:45  
6-28-99 eaa report rec'd. could no duplicate owner's concern. dealer did replace cluth safety switch before inspector left the dealership. alg  
6-28-99 no manufacturing responsibility. requested letter to owner. alg  
6-28-99 letter mailed. alg  
PHOTOGRAPHIC IMAGES POSTED TO THIS CAIR ON 07/08/99 AT 00:00 05915427  
cust states unhappy w/ decision. states will contact his attorney to pursue further legal avenues. seeks to document comments.

**Customer Assistance Inquiry Record (CAIR)#** [REDACTED]

<b>VIN</b>	1B7KC2363 WJ [REDACTED]	<b>Open Date</b>	07/30/1999	<b>Built Date</b>	02/09/1998
<b>Model Year</b>	1998	<b>Body</b>	BE2L33	DODGE RAM 2500 P/U QUAD CAB	
<b>In Service Dt</b>	09/19/1998	<b>Mileage</b>	3,300	<b>Dealer Zone</b>	65 NEW ORLEANS
<b>Plant</b>	J	ST. LOUIS ASSEMBLY II - NORTH	<b>Market</b>	U	US
<b>Dealer</b>	44107	ACADIANA DODGE INCORPORATED			
<b>Dealer Address</b>	1700 SOUTHEAST EVANGELINE HIGHWAY				
<b>Dealer City</b>	LAFAYETTE	<b>Dealer State</b>	LA	<b>Dealer Zip</b>	70508
<b>Owner</b>	[REDACTED]	<b>Contact Type</b>	TELEPHONE		
<b>Address</b>	[REDACTED]	<b>Home Phone</b>	[REDACTED]		
	GLENMORA LA [REDACTED]	<b>Country</b>	UNITED STATES		

Product - Electrical - Starter - Other - Default

Owner alleges that engine started upon key turn, clutch was not engaged, caused truck to run into propane tank, no explosion or fire, but truck is damaged. Vehicle not covered by insurance.

Vehicle located at  
ACADIANA DODGE INCORPORATED DT

LAFAYETTE CNTY OWNER: [REDACTED]

Contact at dealer [REDACTED].

Please contact and arrange for inspection of unit to determine if owners allegations are correct. Provide writer with full PVIR, photos, DRB codes, starter inspection, police reports if written, and all other information.

CAIR NUMBER [REDACTED] REQUEST EAA INSPECTION 07-30-1999 14:58

CAIR NUMBER [REDACTED] FAX SENT TO EAA 07-30-1999 15:00

\*\*\*\*\*

Inspection indicates that vehicle is operating normally, dictated response.

PHOTOGRAPHIC IMAGES POSTED TO THIS CAIR ON 09/24/99 AT 00:00 [REDACTED]

**Customer Assistance Inquiry Record (CAIR)#**

[REDACTED]

<b>VIN</b>	1B7FL26X1 1S [REDACTED]	<b>Open Date</b>	09/18/2001	<b>Built Date</b>	03/13/2001
<b>Model Year</b>	2001	<b>Body</b>	AN1L61	DODGE DAKOTA PICKUP	
<b>In Service Dt</b>	03/23/2001	<b>Mileage</b>	2,299	<b>Dealer Zone</b>	54 ST. LOUIS
<b>Plant</b>	S	WARREN TRUCK ASSEMBLY PLANT 1	<b>Market</b>	U	US
<b>Color</b>	PSB	BRIGHT SILVER METALLIC CLEAR COAT			
<b>Engine</b>	EHC	3.9L V6 SMPI ENGINE			
<b>Transmission</b>	DDC	5-SPEED HD MANUAL TRANSMISSION			

<b>Dealer</b>	67416	WESTPORT AUTO SALES INC
---------------	-------	-------------------------

<b>Dealer Address</b>	RURAL ROUTE 2 BOX #39
-----------------------	-----------------------

<b>Dealer City</b>	LAWRENCEVILLE	<b>Dealer State</b>	IL	<b>Dealer Zip</b>	62439
--------------------	---------------	---------------------	----	-------------------	-------

<b>Owner</b>	[REDACTED]	<b>Contact Type</b>	TELEPHONE
--------------	------------	---------------------	-----------

<b>Address</b>	[REDACTED]	<b>Home Phone</b>	[REDACTED]
----------------	------------	-------------------	------------

VINCENNES IN [REDACTED]	<b>Country</b>	UNITED STATES
-------------------------	----------------	---------------

Product - Engine - Oiling System / Pan / Pump - Low Oil Pressure - Default	States vehicle has been to the dealer three times in less than 3000 miles
--	---

Owner's father calls to document a complaint about the vehicle as it has had to be towed three times now. All three repairs have been different concerns. The first was a clutch master cylinder, the second was a starter/safety switch, and the third is this oil pump shaft. Advised owner his concerns have been noted.

U011205  
U011205

**Customer Assistance Inquiry Record (CAIR)#** [REDACTED]

<b>VIN</b>	1B7MF3373 1J [REDACTED]	<b>Open Date</b>	03/01/2002	<b>Built Date</b>	02/16/2000
<b>Model Year</b>	2001	<b>Body</b>	BE8L34	DODGE RAM 3500 P/U QUAD CAB	
<b>In Service Dt</b>	03/13/2000	<b>Mileage</b>	73,000	<b>Dealer Zone</b>	66 ORLANDO
<b>Plant</b>	J	ST. LOUIS ASSEMBLY II - NORTH	<b>Market</b>	U	US
<b>Color</b>	PW7	BRIGHT WHITE CLEAR COAT			
<b>Engine</b>	ETH	5.9L I6 HO CUMMINS TD ENGINE			
<b>Transmission</b>	DEE	6-SPEED HD MANUAL TRANSMISSION			
<b>Dealer</b>	41562	RALLYE MOTORS INC			
<b>Dealer Address</b>	1749 S W COLLEGE ROAD				
<b>Dealer City</b>	OCALA	<b>Dealer State</b>	FL	<b>Dealer Zip</b>	34474
<b>Owner</b>	[REDACTED]	<b>Contact Type</b>	TELEPHONE		
<b>Address</b>	[REDACTED]	<b>Home Phone</b>	[REDACTED]		
	FORT MC COY FL [REDACTED]	<b>Country</b>	UNITED STATES		

Corporate - Warranty Coverage - Default - Default - Default	clutch switch is not covered under contract
---	---

Customer wants to know if a clutch switch is covered under his service contract. States vehicle is currently at Dealer 41562. Writer contacts Service Advisor Robby - unable to get through at this time. Writer leaves message. Service offered to pay for Labor & Customer pay for parts (89.00) due to past records of complaint (concerns were never duplicated upon those visits). Customer gave authorizations. Writer concurs with offer - Customer is not paying 100.00 deductible, instead is paying 89.00.

**Customer Assistance Inquiry Record (CAIR)#**

[REDACTED]

<b>VIN</b>	1B7KF236X 1J [REDACTED]	<b>Open Date</b>	04/03/2002	<b>Built Date</b>	02/13/2001
<b>Model Year</b>	2001	<b>Body</b>	BE7L34	DODGE RAM 2500 P/U QUAD CAB	
<b>In Service Dt</b>	04/26/2001	<b>Mileage</b>	35,000	<b>Dealer Zone</b>	62 HOUSTON
<b>Plant</b>	J	ST. LOUIS ASSEMBLY II - NORTH	<b>Market</b>	U	US
<b>Color</b>	PR4	FLAME RED CLEAR COAT			
<b>Engine</b>	ETC	5.9L I6 CUMMINS 24V DIESEL ENGINE			
<b>Transmission</b>	DDX	5-SPEED HD MANUAL TRANSMISSION			
<b>Dealer</b>	23855	ARCHER MOTOR SALES CORP			
<b>Dealer Address</b>	8711 N FREEWAY				
<b>Dealer City</b>	HOUSTON	<b>Dealer State</b>	TX	<b>Dealer Zip</b>	77037
<b>Owner</b>	[REDACTED]	<b>Contact Type</b>	TELEPHONE		
<b>Address</b>	[REDACTED]	<b>Home Phone</b>	[REDACTED]		
	ALBANY OK [REDACTED]	<b>Country</b>	UNITED STATES		

Product - Clutch - Unknown - Other - Default

vehicle starts without depressing clutch

4/3/02- First owner contacts DCCAC stating that his vehicle starts without depressing the clutch. Customer states that he had a concern with this previously under warranty. Customer states that he will probably need a new clutch starter interlock switch. Customer states that he is travelling and seeking to find out if any dealers in the area have this part in stock. Contacted dealer 23855 who verified that they had the part in stock. Spoke to service advisor Bryan Bray who advised that he would see what he could do to get the customer in and out of the dealer asap. Advised customer of above. Advised customer that without a proper diagnosis, dealer could not determine how long the repairs would take. Customer understood.

**Customer Assistance Inquiry Record (CAIR)#**

<b>VIN</b>	1B7GG42N3	2S	<b>Open Date</b>	08/26/2002	<b>Built Date</b>	10/19/2001
<b>Model Year</b>	2002	<b>Body</b>	AN5H31	DODGE DAKOTA P/U CLUB CAB-SLT 4X4		
<b>In Service Dt</b>	10/30/2001	<b>Mileage</b>	15,000	<b>Dealer Zone</b>	74	DENVER
<b>Plant</b>	S	WARREN TRUCK ASSEMBLY PLANT 1	<b>Market</b>	U	US	
<b>Color</b>	PDR	GRAPHITE METALLIC CLEAR COAT				
<b>Engine</b>	EVA	4.7L V8 MPI ENGINE				
<b>Transmission</b>	DDC	5-SPEED HD MANUAL TRANSMISSION				
<b>Dealer</b>	38356	PERKINS MOTOR COMPANY INC				
<b>Dealer Address</b>	1205 MOTOR CITY DRIVE					
<b>Dealer City</b>	COLORADO SPRINGS			<b>Dealer State</b>	CO	<b>Dealer Zip</b> 80906
<b>Owner</b>	[REDACTED]				<b>Contact Type</b>	TELEPHONE
<b>Address</b>	[REDACTED]				<b>Home Phone</b>	[REDACTED]
	COLORADO SPRINGS CO [REDACTED]				<b>Country</b>	UNITED STATES

Corporate - Maintenance Requirements - Default - Default - Default

8/26/02 Owner inquires about axle fluid type. Writer advised the owner of the fluid type per the owner's manual. KMC14  
9-20-02 Customer asks if vehicle's transmission has neutral detection, does not, has a clutch safety switch. BAS73

**Customer Assistance Inquiry Record (CAIR)#**

[REDACTED]

<b>VIN</b>	1B7GL2AN7	YS [REDACTED]	<b>Open Date</b>	09/09/2002	<b>Built Date</b>	01/14/2000
<b>Model Year</b>	2000	<b>Body</b>	AN1L84	DODGE DAKOTA P/U QUAD CAB		
<b>In Service Dt</b>	03/28/2000	<b>Mileage</b>	40,000	<b>Dealer Zone</b>	73	SAN FRANCISCO
<b>Plant</b>	S	WARREN TRUCK ASSEMBLY PLANT 1	<b>Market</b>	U	US	
<b>Color</b>	PR4	FLAME RED CLEAR COAT				
<b>Engine</b>	EVA	4.7L V8 MPI ENGINE				
<b>Transmission</b>	DDC	5-SPEED HD MANUAL TRANSMISSION				
<b>Dealer</b>	25024	FIRESIDE DODGE				
<b>Dealer Address</b>	4620 NORTH MCHENRY					
<b>Dealer City</b>	MODESTO	<b>Dealer State</b>	CA	<b>Dealer Zip</b>	95351	
<b>Owner</b>	[REDACTED]				<b>Contact Type</b>	TELEPHONE
<b>Address</b>	[REDACTED]				<b>Home Phone</b>	[REDACTED]
	MODESTO CA [REDACTED]				<b>Country</b>	UNITED STATES

Service Contract - New Contract Coverage - Added Coverage - Component Coverage - Default	Coverage on manual transmission
--	---------------------------------

9/9/02 Owner states that she was advised by dealer 25024 that component that has failed is not covered by her service contract. States that the start interlock clutch switch needs to be replaced. Writer warm transfers owner to service contracts. MAS189

**Customer Assistance Inquiry Record (CAIR)#**

[REDACTED]

<b>VIN</b>	1B7GL12X3 2S [REDACTED]	<b>Open Date</b>	10/21/2002	<b>Built Date</b>	09/18/2001
<b>Model Year</b>	2002	<b>Body</b>	AN1E31	DODGE DAKOTA P/U CLUB CAB 4X2	
<b>In Service Dt</b>	11/15/2001	<b>Mileage</b>	16,386	<b>Dealer Zone</b>	69 PHOENIX
<b>Plant</b>	S	WARREN TRUCK ASSEMBLY PLANT 1	<b>Market</b>	U	US
<b>Color</b>	PW7	BRIGHT WHITE CLEAR COAT			
<b>Engine</b>	EHC	3.9L V6 SMPI ENGINE			
<b>Transmission</b>	DDC	5-SPEED HD MANUAL TRANSMISSION			
<b>Dealer</b>	43389	EARNHARDT'S GILBERT DODGE INC			
<b>Dealer Address</b>	1301 NORTH ARIZONA AVENUE				
<b>Dealer City</b>	GILBERT	<b>Dealer State</b>	AZ	<b>Dealer Zip</b>	85233
<b>Owner</b>	[REDACTED]	<b>Contact Type</b>	TELEPHONE		
<b>Address</b>	[REDACTED]	<b>Home Phone</b>	[REDACTED]		
	APACHE JUNCTION AZ [REDACTED]	<b>Country</b>	UNITED STATES		

Product - Clutch - Unknown - Noisy - Default

10/21/02 1st owner calls stating he has been told by the dealership that he would have to live with the problem he is having. Owner states when he depresses the clutch, there is a squeaking noise. Owner states the vehicle has been back to the dealership about five times. Owner states 43389 has replaced the cylinder clutch and now states there is no repair. Called 43389 and spoke to Jeff, Service Manager (SM). SM states a clutch interlock switch was installed in July. SM referred call to Mike. Mike states clutch master cylinders collect air bubbles in them causes the noise after a few days of driving. Mike states there isn't anything that can be done to repair because this is a normal characteristic of the vehicle. Advised owner of above and that if he disagrees with the diagnosis, he is welcome to seek a second opinion from another DCX dealership. HLM14

**Customer Assistance Inquiry Record (CAIR)#**

[REDACTED]

<b>VIN</b>	1B7FL22P1	WS [REDACTED]	<b>Open Date</b>	04/02/2003	<b>Built Date</b>	10/14/1997
<b>Model Year</b>	1998	<b>Body</b>	AN1L31	DODGE DAKOTA P/U CLUB CAB		
<b>In Service Dt</b>	12/13/1997	<b>Mileage</b>	76,000	<b>Dealer Zone</b>	71	LOS ANGELES
<b>Plant</b>	S	WARREN TRUCK ASSEMBLY PLANT 1	<b>Market</b>	U	US	

<b>Dealer</b>	42947	AUTOWEST CHRYSLER JEEP DODGE
---------------	-------	------------------------------

<b>Dealer Address</b>	230 AUTOMALL DR	
-----------------------	-----------------	--

<b>Dealer City</b>	ROSEVILLE	<b>Dealer State</b>	CA	<b>Dealer Zip</b>	95661
--------------------	-----------	---------------------	----	-------------------	-------

<b>Owner</b>	[REDACTED]	<b>Contact Type</b>	TELEPHONE
--------------	------------	---------------------	-----------

<b>Address</b>	[REDACTED]	<b>Home Phone</b>	[REDACTED]
----------------	------------	-------------------	------------

ROSEVILLE CA [REDACTED]	<b>Country</b>	UNITED STATES
-------------------------	----------------	---------------

Dealer - Parts - Transaction - Excessive Cost - Default	Order whole system to replace a safety switch
Product - Transmission / Transaxle - Manual Trans / Transaxle - Other - Default	safety switch will not work and allow the vehicle to start

04/02/03 Original owner called regarding a concern with not being able to order the safety switch for the clutch. Owner advised that only the switch has failed and he is being told that he will have to order the entire system. Owner advised that he feels that this is not reasonable. Writer advised that the concern has been documented. Writer advised that the owner can check salvage yards to see if he can find the switch. Writer advised that through Mopar only the whole unit can be purchased.

**Customer Assistance Inquiry Record (CAIR)#** [REDACTED]

<b>VIN</b>	3B7KF2677	1M [REDACTED]	<b>Open Date</b>	09/18/2003	<b>Built Date</b>	04/04/2000
<b>Model Year</b>	2001	<b>Body</b>	BR7L62	DODGE RAM 2500 PICKUP		
<b>In Service Dt</b>	08/28/2000	<b>Mileage</b>	51,000	<b>Dealer Zone</b>		
<b>Plant</b>	M	MEXICO CITY ASSEMBLY PLANT	<b>Market</b>	U	US	
<b>Color</b>	PW7	BRIGHT WHITE CLEAR COAT				
<b>Engine</b>	ETH	5.9L I6 HO CUMMINS TD ENGINE				
<b>Transmission</b>	DEE	6-SPEED HD MANUAL TRANSMISSION				

<b>Owner</b>	[REDACTED]	<b>Contact Type</b>	TELEPHONE
<b>Address</b>	[REDACTED]	<b>Home Phone</b>	[REDACTED]
	DEMING NM [REDACTED]	<b>Country</b>	UNITED STATES

---

Product - Drivability - Unknown - No Start - Default
--

---

Diesel engine won't start.
----------------------------

---

Original owner called stating that she contacted roadside to get her vehicle towed with the Cummins diesel engine, and roadside informed customer that vehicle is outside of warranty. Spoke to Ken at roadside, and informed him of the five year 100,000 mile diesel warranty. Per supervisor, vehicle is outside of warranty, and roadside would not cover this tow. MFP is looking into this matter to see if this should be covered by roadside.

Customer can be reached at [REDACTED].

Per MFP customer can have vehicle towed to Dodge dealer, and if the failure is due to one of the covered components under the Cummins diesel warranty, dealer can charge this to warranty. Left message for customer informing her of this.

---

**Customer Assistance Inquiry Record (CAIR)#** [REDACTED]

<b>VIN</b>	1D7FL16X1 3S [REDACTED]	<b>Open Date</b>	11/12/2003	<b>Built Date</b>	06/16/2003
<b>Model Year</b>	2003	<b>Body</b>	AN1E61	DODGE DAKOTA P/U REGULAR CAB 4X2	
<b>In Service Dt</b>	06/26/2003	<b>Mileage</b>	8,523	<b>Dealer Zone</b>	35 WASHINGTON
<b>Plant</b>	S	WARREN TRUCK ASSEMBLY PLANT 1	<b>Market</b>	U	US
<b>Color</b>	PRV	DK. GARNET RED PEARL COAT			
<b>Engine</b>	EHC	3.9L V6 SMPI ENGINE			
<b>Transmission</b>	DDC	5-SPEED HD MANUAL TRANSMISSION			

<b>Dealer</b>	42483	VIRGINIA BEACH DODGE INC			
<b>Dealer Address</b>	3443 VIRGINIA BEACH BLVD				
<b>Dealer City</b>	VIRGINIA BEACH	<b>Dealer State</b>	VA	<b>Dealer Zip</b>	23452

<b>Owner</b>	[REDACTED]	<b>Contact Type</b>	TELEPHONE
<b>Address</b>	[REDACTED]	<b>Home Phone</b>	
	NORFOLK VA [REDACTED]	<b>Country</b>	UNITED STATES

Product - Clutch - Unknown - Other - Default	Customer states that vehicle can be started without clutch in.
Recall - C35: HEADLAMP AND DASH WIRING HARNESS - Information Request	Customer wanted information on what this affects.
Corporate - Warranty Coverage - Default - Default - Default	Customer wanted warranty information.

CF169 11/12/03 The customer received recall C35 and wanted to know what this recall included. Writer advised customer of what the recall includes and advised customer to contact the dealership to make an appointment. The customer stated that when she starts her vehicle the clutch does not need to be pressed for the vehicle to start and the customer wanted to know if this was alright. Writer advised customer to have dealership look at the vehicle. The customer wanted to know what was covered under her warranty so writer provided warranty number.

**Customer Assistance Inquiry Record (CAIR)#**

[REDACTED]

<b>VIN</b>	3D7LU38C7 3G [REDACTED]	<b>Open Date</b>	06/07/2004	<b>Built Date</b>	03/12/2003
<b>Model Year</b>	2003	<b>Body</b>	DR8H42	DODGE RAM 3500 QUAD CAB PICKUP	
<b>In Service Dt</b>	09/23/2003	<b>Mileage</b>	15,000	<b>Dealer Zone</b>	63 DALLAS
<b>Plant</b>	G	SALTILLO TRUCK ASSEMBLY PLANT	<b>Market</b>	U	US
<b>Color</b>	PW7	BRIGHT WHITE CLEAR COAT			
<b>Engine</b>	ETH	5.9L I6 HO CUMMINS TD ENGINE			
<b>Transmission</b>	DEE	6-SPEED HD MANUAL TRANSMISSION			
<b>Dealer</b>	44524	JIM MCNATT DODGE			
<b>Dealer Address</b>	4100 I-35 SOUTH				
<b>Dealer City</b>	DENTON	<b>Dealer State</b>	TX	<b>Dealer Zip</b>	76210
<b>Owner</b>	[REDACTED]	<b>Contact Type</b>	TELEPHONE		
<b>Address</b>	[REDACTED]	<b>Home Phone</b>	[REDACTED]		
	DENTON TX [REDACTED]	<b>Country</b>	UNITED STATES		

Product - Drivability - Unknown - Other - Default

Recurring problems with vehicle

Original owner calls regarding vehicle currently being towed to dealer 44524. Vehicle has not been diagnosed yet. Owner is seeking assistance for a loaner vehicle. Advised owner to get a diagnosis before any decision from DCX can be made. Owner agreed.  
6/9/04 Owner is calling back seeking rental. Owner alleges dealer 44524 told him that the part has not come in yet for a relay switch for clutch. Writer tried to call service manager. Service manager is not in and service advisor (SA) will not be back from lunch until an hour. Writer will call SA back in an hour. Writer informed owner of above and will give owner a call back at [REDACTED] after speaking with SA.  
Writer called owner back and informed that vehicle is ready to be picked up.

**Customer Assistance Inquiry Record (CAIR)#**

[REDACTED]

<b>VIN</b>	1D7HL38X3 3S [REDACTED]	<b>Open Date</b>	06/06/2006	<b>Built Date</b>	02/11/2003
<b>Model Year</b>	2003	<b>Body</b>	AN1M84	DODGE DAKOTA P/U QUAD CAB-SPORT 4X2	
<b>In Service Dt</b>	04/05/2003	<b>Mileage</b>	30,400	<b>Dealer Zone</b>	63 DALLAS
<b>Plant</b>	S	WARREN TRUCK ASSEMBLY PLANT 1	<b>Market</b>	U	US
<b>Color</b>	PSB	BRIGHT SILVER METALLIC CLEAR COAT			
<b>Engine</b>	EHC	3.9L V6 SMPI ENGINE			
<b>Transmission</b>	DDC	5-SPEED HD MANUAL TRANSMISSION			
<b>Dealer</b>	66605	TUPELO AUTO SALES LTD			
<b>Dealer Address</b>	1608 SOUTH GLOSTER				
<b>Dealer City</b>	TUPELO	<b>Dealer State</b>	MS	<b>Dealer Zip</b>	38801
<b>Owner</b>	[REDACTED]	<b>Contact Type</b>	TELEPHONE		
<b>Address</b>	[REDACTED]	<b>Home Phone</b>	[REDACTED]		
	BALDWYN MS [REDACTED]	<b>Country</b>	UNITED STATES		

Product - Clutch - Unknown - Complete Failure - Default

Customer states that the clutch pedal switch has gone out.

Customer states that his clutch pedal switch has gone out. Customer is seeking assistance with the repairs. Customer states that the vehicle is at dealer66605. Transferred customer for further assistance.

\*\*\*\*\* Internal Transfer \*\*\*\*\*

Customer states that the clutch switch has failed on the vehicle. Customer states that the vehicle is currently at dealership and has been diagnosed. Agent contacted dealership 66605 and spoke with David - Service Manager who states that the vehicle is at the dealership with a clutch pedal switch failure. Agent advised customer that no assistance will be provided due to manual clutch components are not covered under any warranty and considered a wear item.

**Customer Assistance Inquiry Record (CAIR)#** [REDACTED]

<b>VIN</b>	1D7HA18K9 3J [REDACTED]	<b>Open Date</b>	07/13/2006	<b>Built Date</b>	05/21/2003
<b>Model Year</b>	2003	<b>Body</b>	DR1L41	DODGE RAM 1500 QUAD CAB PICKUP	
<b>In Service Dt</b>	12/11/2003	<b>Mileage</b>	27,000	<b>Dealer Zone</b>	63 DALLAS
<b>Plant</b>	J	ST. LOUIS ASSEMBLY II - NORTH	<b>Market</b>	U	US
<b>Color</b>	PKJ	LT. ALMOND PEARL METALLIC CLEAR COAT			
<b>Engine</b>	EKG	3.7L V6 ENGINE			
<b>Transmission</b>	DDC	5-SPEED HD MANUAL TRANSMISSION			
<b>Dealer</b>	44990	ALLEN SAMUELS DODGE			
<b>Dealer Address</b>	21777 KATY FREEWAY				
<b>Dealer City</b>	KATY	<b>Dealer State</b>	TX	<b>Dealer Zip</b>	77450
<b>Owner</b>	[REDACTED]	<b>Contact Type</b>	ROADSIDE		
<b>Address</b>	[REDACTED]	<b>Home Phone</b>			
	HOUSTON TX [REDACTED]	<b>Country</b>	UNITED STATES		

Corporate - Roadside Services - Warranty - Towing - Default

Roadside Assistance Contacted - DATE : 2006-07-11  
Road Side File Created 07-13-06 FOR WARRANTYCALLER\_COMMENTS 01-CLUTCH SWITCH BROKE TOW\_COMMEN  
DEALER CODE : [REDACTED]

**Customer Assistance Inquiry Record (CAIR)#** [REDACTED]

<b>VIN</b>	3B7MC33C52M [REDACTED]	<b>Open Date</b>	09/18/2006	<b>Built Date</b>	04/03/2002
<b>Model Year</b>	2002	<b>Body</b>	BE3L34	DODGE RAM 3500 P/U QUAD CAB	
<b>In Service Dt</b>	06/30/2002	<b>Mileage</b>	69,000	<b>Dealer Zone</b>	66 ORLANDO
<b>Plant</b>	M	MEXICO CITY ASSEMBLY PLANT	<b>Market</b>	U	US
<b>Color</b>	PW7	BRIGHT WHITE CLEAR COAT			
<b>Engine</b>	ETH	5.9L I6 HO CUMMINS TD ENGINE			
<b>Transmission</b>	DEE	6-SPEED HD MANUAL TRANSMISSION			
<b>Dealer</b>	43654	JERRY ULM DODGE CHRYSLER JEEP			
<b>Dealer Address</b>	2966 NORTH DALE MABRY HIGHWAY				
<b>Dealer City</b>	TAMPA	<b>Dealer State</b>	FL	<b>Dealer Zip</b>	33607
<b>Owner</b>	[REDACTED]	<b>Contact Type</b>	TELEPHONE		
<b>Address</b>	[REDACTED]	<b>Home Phone</b>	[REDACTED]		
	TAMPA FL [REDACTED]	<b>Country</b>	UNITED STATES		

Referral - Tier Three - Default - Default - Default	Tier three support referral.
Product - Clutch - Unknown - Other - Default	clutch/starter interlock
Corporate - Property Damage - Default - Default - Default	
Product - Transmission / Transaxle - Manual Trans / Transaxle - Improper Shift - Default	
Product - Unknown - Unknown - Accident - Default	

Customer states that in the owner s manual it states that the vehicle can not be started without the clutch fully depressed. Customer states that his brother started the vehicle from outside with the door open. Customer states that the vehicle went backwards and took the door off and damaged the front panel. Customer states that the vehicle hit his brothers Ford F250 and pushed it 7 feet while in park. Customer states that it caused front bumper damage to the Ford. Customer states it also caused damage to the back bumper of his vehicle. Customer states he is filing with his insurance.

Agent transferred to Tier 3 for further review.

Insurance Co: Geico Insurance

Claim # [REDACTED] 4

Agent: [REDACTED]

No Police report

No physical injuries.

Vehicle location: [REDACTED]

\*\*\*\*\*

VEHICLE IS LOCATED AT:

[REDACTED]

Per OGC Matrix, reassigned to 82T. JSS15.

9/18/06 sending back to SI for F/I/P Codes thanks jlg117

9-18-06 Assigned to TK27/SSS8

CAIR NUMBER [REDACTED] REQUEST EAA INSPECTION 09-18-2006 11:39

CAIR NUMBER [REDACTED] E-MAIL SENT TO EAA 09-18-2006 11:39

Inspection Requested: 9/18/2006 (KThornton)

inspection Conducted: 9/21/2006 (KSmolinski)

Inspection Report Received: 9/21/2006 (KSmolinski)

Resolution Letter Sent: 9/22/2006 (KSmolinski)

Customer states the letter he received letter stating that the inspector determined no malfunction. Customer seeking if the inspector tried starting the vehicle without pressing the clutch. Agent referred customer to Customer Claims Resolution Group (CCRG) [REDACTED] receive an update. Customer understood.  
3/25/08 VCW2 updated car image from pending to X.  
Image may not be available due to technical issue.

---

**Customer Assistance Inquiry Record (CAIR)#**

[REDACTED]

<b>VIN</b>	3D7KS26C0	7G [REDACTED]	<b>Open Date</b>	05/18/2007	<b>Built Date</b>	10/16/2006
<b>Model Year</b>	2007	<b>Body</b>	DH7H62	DODGE RAM SLT 4X4 2500 REG. CAB		
<b>In Service Dt</b>	12/28/2006	<b>Mileage</b>	7,596	<b>Dealer Zone</b>	71	LOS ANGELES
<b>Plant</b>	G	SALTILLO TRUCK ASSEMBLY PLANT	<b>Market</b>	U	US	
<b>Color</b>	PW7	BRIGHT WHITE CLEAR COAT				
<b>Engine</b>	ETH	5.9L HO CUMMINS TURBO DIESEL ENGINE				
<b>Transmission</b>	DEG	6-SPEED MANUAL G56 TRANSMISSION				

<b>Dealer</b>	43231	RON TONKIN DODGE INC				
<b>Dealer Address</b>	19300 MCLOUGHLIN BLVD					
<b>Dealer City</b>	GLADSTONE	<b>Dealer State</b>	OR	<b>Dealer Zip</b>	97027	

<b>Owner</b>	[REDACTED]	<b>Contact Type</b>	TELEPHONE
<b>Address</b>	[REDACTED]	<b>Home Phone</b>	[REDACTED]
	CLACKAMAS OR [REDACTED]	<b>Country</b>	UNITED STATES

Product - Clutch - Unknown - Defective - Default	Customer needs clutch switch.
Corporate - Rental Vehicle - Default - Default - Default	Customer seeks rental assistance.

\*\*\*\*Begin structured narrative CL-RENTAL

Is the vehicle still under warranty?

yes

Does the vehicle have any service contract that covers rental?

no

What repairs are currently being completed?

a clutch switch

Why has the vehicle not been repaired and returned to the owner?

the part is unavailable

What is the estimated date that the repair will be completed?

05/21/2007

Is this a recall repair?

no

Is this a pre-authorization or a request for reimbursement?

reimbursement

DCX authorizes rental? Explain why or why not...

yes, vehicle is down at dealer

How many days are being authorized and at what dollar amount?

3 days per Warranty Bulletin D-04-26

\*\*\*\*End structured narrative CL-RENTAL

Purchased New or Used? New

If Used, date purchased? Mileage?

From whom did customer purchase used vehicle?

Other dealer

Customer is calling in seeking rental assistance. The vehicle is down at dealer waiting on a part due in monday. Agent contacted dealer and spoke with [REDACTED], the advisor on the vehicle. Tom advised the vehicle will be in for the weekend and the part will be in Monday and expects it to be replaced then.

Customer calls seeking rental assistance because the servicing dealer will not have the part until Monday, the 21st. Contacted Service Manager, Tom at 43231 to discuss the customer s request for rental assistance. Confirmed customer s concern and with Service Manager concurrence, authorized 3 of daysU days of rental per guidelines in Warranty Bulletin D-04-26.

per MLB92

---

**Customer Assistance Inquiry Record (CAIR)#**

[REDACTED]

<b>VIN</b>	1D7HE22K6 6S [REDACTED]	<b>Open Date</b>	12/03/2007	<b>Built Date</b>	04/26/2006
<b>Model Year</b>	2006	<b>Body</b>	ND1L33	DODGE DAKOTA ST CLUB CAB 4X2	
<b>In Service Dt</b>	05/28/2006	<b>Mileage</b>	35,582	<b>Dealer Zone</b>	71 LOS ANGELES
<b>Plant</b>	S	WARREN TRUCK ASSEMBLY PLANT 1	<b>Market</b>	U	US
<b>Color</b>	PW7	BRIGHT WHITE CLEAR COAT			
<b>Engine</b>	EKG	"MAGNUM" 3.7L V6 ENGINE			
<b>Transmission</b>	DEJ	6-SPEED MANUAL GETRAG 238 TRANS			

<b>Dealer</b>	44544	AVONDALE DODGE			
<b>Dealer Address</b>	10101 W PAPAGO FWY				
<b>Dealer City</b>	AVONDALE	<b>Dealer State</b>	AZ	<b>Dealer Zip</b>	85323

<b>Owner</b>	[REDACTED]	<b>Contact Type</b>	D2D NO CASE MANAGER
<b>Address</b>	[REDACTED]	<b>Home Phone</b>	[REDACTED]
	BUCKEYE AZ [REDACTED]	<b>Country</b>	UNITED STATES

Corporate - Rental Vehicle - Default - Default - Default	Customer requesting rental vehicle.
--	-------------------------------------

Purchased New or Used? new

If Used, date purchased? N/A Mileage? N/A

From whom did customer purchase used vehicle?

N/A

Agent contacted dealership and spoke with Mike and he verified the repair, and then transferred agent to parts. Agent asked Jose what the order status was on the parts and he stated that it was on daily.

Agent advised Jose to put the parts on VOR and he stated that he will do it now. Part #5134623ae order #1203dd.

Agent asked if it could be arranged for the customer to get a rental vehicle.

\*\*\*\*Begin structured narrative T2 - RENTAL

Is the vehicle still under warranty?

yes

Does the vehicle have any service contract that covers rental?

no

What repairs are currently being completed?

clutch switch

Why has the vehicle not been repaired and returned to the owner?

parts are on order

What is the estimated date that the repair will be completed?

12/05/07

Is this a recall repair?

no

Is this a pre-authorization or a request for reimbursement?

pre authorized

Chrysler authorizes rental? Explain why or why not...

yes, the parts are on order and vehicle should be ready 12/05/07

How many days are being authorized and at what dollar amount?

3 days at \$40 pre day for a total of \$120.

\*\*\*\*End structured narrative T2 - RENTAL

\$\$\$\$\$ DIRECT-TO-DEALER 4B \$\$\$\$\$\$\$\$\$\$

ATTENTION SERVICE DIRECTOR OR SERVICE MANAGER

This Direct-to-Dealer CAIR is being sent for the following reason:

Vehicle off road

Please update this CAIR as required.

Agent called dealer and spoke to Russ to inform that CAIR was being sent.

\$

REASSIGNED TO BC/DLR 71 44544 12/04/07 10:38 R 1 [REDACTED]

\*Contact Date:12/12/2007

Service Director at the dealership has closed the Cair# [REDACTED]

Warranty repair has been documented on Repair Order [REDACTED]

CAIR RETURNED FROM DEALER ON 12/12/2007 AT 01:20:413 R [REDACTED]

---

**Customer Assistance Inquiry Record (CAIR)#**

[REDACTED]

<b>VIN</b>	1D7HA16K9 6 [REDACTED]	<b>Open Date</b>	03/10/2008	<b>Built Date</b>	12/06/2005
<b>Model Year</b>	2006	<b>Body</b>	DR1L61	DODGE RAM 1500 ST REG CAB 4X2	
<b>In Service Dt</b>	01/12/2006	<b>Mileage</b>	11,700	<b>Dealer Zone</b>	63 DALLAS
<b>Plant</b>	J	ST. LOUIS ASSEMBLY II - NORTH	<b>Market</b>	U	US
<b>Color</b>	PW7	BRIGHT WHITE CLEAR COAT			
<b>Engine</b>	EKG	"MAGNUM" 3.7L V6 ENGINE			
<b>Transmission</b>	DEJ	6-SPEED MANUAL GETRAG 238 TRANS			
<b>Dealer</b>	45107	DODGE CITY OF MCKINNEY			
<b>Dealer Address</b>	700 S CENTRAL EXPY				
<b>Dealer City</b>	MCKINNEY	<b>Dealer State</b>	TX	<b>Dealer Zip</b>	75070
<b>Owner</b>	[REDACTED]	<b>Contact Type</b>	TELEPHONE		
<b>Address</b>	[REDACTED]	<b>Home Phone</b>	[REDACTED]		
	MIDLOTHIAN TX [REDACTED]	<b>Country</b>	UNITED STATES		

Recall - F40: PASSENGER AIRBAG CUSHION - Advise Owner/Incomplete Recall	Advised of incomplete recall F40
Recall - F41: FRONT PASSENGER SEAT BELT - Advise Owner/Incomplete Recall	Advised of incomplete recall F41
Recall - G02: 06-DR HUB BEARINGS - Advise Owner/Incomplete Recall	Advised of incomplete recall G03
Corporate - Warranty Coverage - Default - Default - Default	Customer seeking reimbursement for clutch switch
Product - Electrical - Lamps and Switches - Intermittent or Inoperative - Default	Customer stated clutch switch went out

Purchased New or Used? Used

If Used, date purchased? 09/04/07 Mileage? Not sure

From whom did customer purchase used vehicle? Independent

Customer stated clutch switch went out and an independent did the repair because he could not get to a dealer. Customer seeking reimbursement for clutch switch that was replaced at independent. Advised warranty work must be done at CDJ dealer so no reimbursement will be offered for work done at independent. Advised of incomplete recalls F40, F41, and G02 that need to be taken care of at local Dodge dealer.

**Customer Assistance Inquiry Record (CAIR)#** [REDACTED]

<b>VIN</b>	3D7KS28CX 7G [REDACTED]	<b>Open Date</b>	02/06/2009	<b>Built Date</b>	10/18/2006
<b>Model Year</b>	2007	<b>Body</b>	DH7H42 DODGE RAM SLT 4X4 2500 QUAD CAB		
<b>In Service Dt</b>	07/31/2007	<b>Mileage</b>	1	<b>Dealer Zone</b>	63 DALLAS
<b>Plant</b>	G	SALTILLO TRUCK ASSEMBLY PLANT	<b>Market</b>	U	US
<b>Color</b>	PB7 PATRIOT BLUE PEARL COAT				
<b>Engine</b>	ETH 5.9L HO CUMMINS TURBO DIESEL ENGINE				
<b>Transmission</b>	DEG 6-SPEED MANUAL G56 TRANSMISSION				
<b>Dealer</b>	44565	FRANK FLETCHER DODGE-CHRYSLER-JEEP			
<b>Dealer Address</b>	5922 WARDEN RD.				
<b>Dealer City</b>	SHERWOOD	<b>Dealer State</b>	AR	<b>Dealer Zip</b>	72120
<b>Owner</b>	[REDACTED]	<b>Contact Type</b>	TELEPHONE		
<b>Address</b>	[REDACTED]	<b>Home Phone</b>	[REDACTED]		
	KEMP TX [REDACTED]	<b>Country</b>	UNITED STATES		

Product - Transmission / Transaxle - Manual Trans / Transaxle - Jumps Out of Gear/Park - Default	jumper forward during repairs
Corporate - Property Damage - Default - Default - Default	
Product - Drivability - Unknown - Sudden Acceleration - Default	
Product - Unknown - Unknown - Accident - Default	

Complaint forwarded by SW business Center via dealer SM:

THIS IS [REDACTED] SHOP FOREMAN DEALER CODE 44565 FLETCHER DODGE IN SHERWOOD AR  
 WE HAD AN INCIDENT OCURR MONDAY AFTERNOON THAT I THINK SOMEONE AT CHRYSLER NEEDS TO BE AWARE OF  
 I HAD A TECHNICIAN REPROGRAM AN ECM ON A 2006 2500 LAST 9 OF VIN ARE X7G [REDACTED] WHEN THE STARS SCAN WAS THROUGH FLASHING HE HAD TO REPROGRAM SKREEM PIN SO HE DID SO STARS SCAN INSTRUCTS YOU TO CYCLE THE KEY BEFORE ATTEMPTING TO START TO AVOID A START AND STALL CONDITION HE DID SO AND AS SOON AS THE KEY WAS ROLLED BACK ON THE TRUCK STARTED AND TOOK OFF LITERALLY IT WAS IN 1ST GEAR AND PARK BRAKE WAS ON WITH [REDACTED] ANGING ON FOR DEAR LIFE. THIS TRUCK IS A 6 SPEED MANUAL AND HE WAS STANDING OUTSIDE TRUCK WHEN THIS OCCURED WITH NO INPUT TO THE CLUTCH PEDAL THERE IS NO WAY THIS TRUCK SHOULD HAVE EVEN ENGAGED THE STARTER WITHOUT CLUTCH PEDAL DEPRESSED AFTER I MADE SURE EVERYBODY WAS OK I JUMPED IN TRUCK TO ATTEMPT TO DUPLICATE AND COULD NOT AND STILL CANT NEEDLESS TO SAY IT MADE A PRETTY GOOD MESS OF THE TRUCK AND OUR SHOP WALL I DONT KNOW IF THE CLUTCH SWITCH WAS MOMENTARILY STUCK (I DID CHECK IT ) EVERYTHING SEEMS NORMAL THERE ARE NO AFTERMARKET FEATURES ON THIS TRUCK EXCEPT SOME SORT OF IGNITION INTERRUPTOR I CONTACTED STAR AND THEY HAVE NO REPORTS OF SOMETHNG LIKE THIS HAPPENING NOW THE CUSTOMER KNOWS WHAT HAPPENED I DONT KNOW WHAT (IF ANY ) RECOURSE WILL HAPPEN I JUST THOUGHT I WOULD LET YOU KNOW IN CASE SOMTHING DOES HAPPEN I WOULD STILL LIKE TO KNOW WHY IT HAPPENED BUT THAT MAY NEVER HAPPEN THANKS AND IF YOU SHOULD NEED MORE INFOOR HAVE QUESTIONS MY NUMBERS ARE [REDACTED] DIRECT TO MY DESK THANKS AGAIN

VEHICLE IS LOCATED AT:  
 [REDACTED]

Per OGC Matrix, reassigned to 82T. JSS15.

2-6-09 Assigned to TNT16. MJK

CAIR NUMBER [REDACTED] REQUEST EAA INSPECTION 02-06-2009 12:06

CAIR NUMBER [REDACTED] E-MAIL SENT TO EAA 02-06-2009 12:06

CCRG Open Date: 02/06/2009 10:12:54

PHOTOGRAPHIC IMAGES POSTED TO THIS CAIR ON 02/09/09 AT 16:40:18 1 [REDACTED]

Letter Sent: Acknowledgement 02/09/2009 10:52:18

---

**Customer Assistance Inquiry Record (CAIR)#** [REDACTED]

<b>VIN</b>	3D6WH48A6	7G [REDACTED]	<b>Open Date</b>	02/23/2009	<b>Built Date</b>	03/09/2007
<b>Model Year</b>	2007	<b>Body</b>	DC8L43	DODGE RAM 4X4 3500 QUAD CAB CHASSIS		
<b>In Service Dt</b>	10/16/2007	<b>Mileage</b>	19,500	<b>Dealer Zone</b>	63	DALLAS
<b>Plant</b>	G	SALTILLO TRUCK ASSEMBLY PLANT	<b>Market</b>	U	US	
<b>Color</b>	PR4	FLAME RED CLEAR COAT				
<b>Engine</b>	ETJ	6.7L CUMMINS TURBO DIESEL ENGINE				
<b>Transmission</b>	DEG	6-SPEED MANUAL G56 TRANSMISSION				
<b>Dealer</b>	57984	SPRINGDALE DODGE CHRYSLER				
<b>Dealer Address</b>	3709 SOUTH THOMPSON					
<b>Dealer City</b>	SPRINGDALE	<b>Dealer State</b>	AR	<b>Dealer Zip</b>	72764	
<b>Owner</b>	[REDACTED]			<b>Contact Type</b>	E-MAIL	
<b>Address</b>	[REDACTED]			<b>Home Phone</b>		
	HUNTSVILLE AR [REDACTED]			<b>Country</b>	UNITED STATES	

Product - Unknown - Unknown - Fire - Engine Compartment	.
Product - Unknown - Unknown - Poor Idle Quality - Default	Customer complains about the product quality.
Dealer - Service/Body Shop - Transaction - Other - Default	Customer complains about the services of the dealership (57984)
Dealer - Sales - Transaction - Incorrectly Equipped - Default	Customer complains of the vehicle being ill equipped (no trailer brakes).
Dealer - Service/Body Shop - Transaction - Problem Not Resolved - Default	Customer complains that dealership denied services.
Referral - Tier Three - Default - Default - Default	Customer complains that the vehicle started on its own & caught fire.
Recall - H34: DASH SHIELD - Other	To inform the customer about the incomplete recall.
Corporate - Property Damage - Default - Default - Default	
Product - Unknown - Unknown - Fire - Unknown	

\*\*\*\*\* EMAIL BRIEF DESCRIPTION CONTENT \*\*\*\*\*

Dealership and truck are pieces of junk.

\*\*\*\*\* END EMAIL BRIEF DESCRIPTION CONTENT \*\*\*\*\*

Purchased New or Used? New

Is the vehicle at a Chrysler/Dodge/Jeep dealer now? No

\*\*\*\*\* BEGIN CUSTOMER EMAIL \*\*\*\*\*

I purchased the truck in October 2007. The truck had a flat bed already on it. The first time I pulled a trailer, I realized, I did not have any trailer brakes. I returned it to the dealer to have it repaired. They told me I would have to take it elsewhere, they would not make the repairs. There has been numerous things I have requested to be done regarding the vehicle and Springdale dodge is of no help. I was warned not to go there by other people. It seems all they are concerned with is selling a vehicle. They will not stand behind the product. The last incident was last week when the truck was trying to start by itself and caught on fire. I was on top of a house working at the time. Springdale Dodge would not send someone out to tow the vehicle to them. I had to call Chrysler roadside assistance to get them to send someone to tow the truck. The truck has been at the dealership for almost a week now, and they have yet to contact me. I do not want the vehicle back and I need to talk to someone about this problem. If someone would please call me at

[REDACTED] home, or [REDACTED] cell. I would greatly appreciate it.

RESPONSE \*\*\*\*\*

Escalated to Tier 3. There is an incomplete recall on the vehicle (Recall Campaign # H34 - Dash Shield). (Consulted GK222)

\*\*\*\*\* END RESPONSE \*\*\*\*\*

Customer is not happy with dealer 57984.

COIN Updated & CAIR reassigned to 82S

Contact: [REDACTED]

Telephone # [REDACTED]

LOCATION OF VEHICLE - INCLUDING THE ADDRESS: SPRINGDALE DODGE CHRYSLER,

[REDACTED]  
What happened?: Customer states insert summary of event(s)U Customer was up on his roof on either 2/16 or 17/09 and a neighbor asked what was wrong with his vehicle because it was trying to start by itself. Customer got off roof and the only reason the vehicle did not start was because the parking brake was on. Customer states that he had to disconnect battery to stop the fire.

REASSIGNED TO BC/DLR 63 57984 02/23/09 15:59 R [REDACTED]

Email states:

Dear [REDACTED]: Thank you for contacting the Chrysler Customer Assistance Center regarding your 2007 Dodge Ram. Our records show that you have contacted us by telephone and we have forwarded your file to our special investigations department for further review. We have updated your file to reflect the latest information you provided in the email message.

Our records indicate that the following recall campaign was just issued and has not been performed by an authorized dealer: H34 DASH SHIELD Please take a copy of this message with you at the time of service to aid the process. Please note that your dealership does not require a copy of the recall notice to perform the needed service. If you wish to obtain further information, please contact our Recall Assistance Center at [REDACTED]

Thanks again for your email.

\*\*\* File was not sent to 82S as stated on line 28 \*\*\*

\*\*\*\*\*

03.03.09

Per OGC Matrix, reassigned to 82T. MG17.

3.3.09 Assigned to RLG92. MJK

3.3.09 One Open Recall:

\_ H34 57984 OPEN DASH SHIELD SAFETY

CAIR NUMBER 1 [REDACTED] REQUEST EAA INSPECTION 03-03-2009 15:09

CAIR NUMBER 1 [REDACTED] E-MAIL SENT TO EAA 03-03-2009 15:09

CCRG Open Date: 03/03/2009 11:44:34

Letter Sent: Acknowledgement 03/04/2009 12:07:59

PHOTOGRAPHIC IMAGES POSTED TO THIS CAIR ON 03/06/09 AT 09:32:30 [REDACTED]

PHOTOGRAPHIC IMAGES POSTED TO THIS CAIR ON 03/11/09 AT 18:41:06 [REDACTED]

---

**Customer Assistance Inquiry Record (CAIR)#** [REDACTED]

<b>VIN</b>	1D7HA16KX 6J [REDACTED]	<b>Open Date</b>	12/22/2009	<b>Built Date</b>	09/01/2005
<b>Model Year</b>	2006	<b>Body</b>	DR1L61	DODGE RAM 1500 ST REG CAB 4X2	
<b>In Service Dt</b>	11/07/2006	<b>Mileage</b>	39,059	<b>Dealer Zone</b>	63 DALLAS
<b>Plant</b>	J	ST. LOUIS ASSEMBLY II - NORTH	<b>Market</b>	U	US
<b>Color</b>	PW7	BRIGHT WHITE CLEAR COAT			
<b>Engine</b>	EKG	"MAGNUM" 3.7L V6 ENGINE			
<b>Transmission</b>	DEJ	6-SPEED MANUAL GETRAG 238 TRANS			
<b>Dealer</b>	67879	WOLFCHASE CHRYSLER DODGE JEEP			
<b>Dealer Address</b>	8170 U S HIGHWAY 64				
<b>Dealer City</b>	BARTLETT	<b>Dealer State</b>	TN	<b>Dealer Zip</b>	38133
<b>Owner</b>	[REDACTED]	<b>Contact Type</b>	E-MAIL		
<b>Address</b>	[REDACTED]	<b>Home Phone</b>	[REDACTED]		
	LAKELAND TN [REDACTED]	<b>Country</b>	UNITED STATES		

Corporate - Complaint Contact - Default - Default - Default	
Dealer - Service/Body Shop - Personnel - Lack of Product Knowledge - Unknown	
Dealer - Service/Body Shop - Transaction - Problem Not Resolved - Default	
Product - Clutch - Unknown - Noisy - Default	
Product - Electrical - Unknown - Defective - Default	

\*\*\*\*\* EMAIL BRIEF DESCRIPTION CONTENT \*\*\*\*\*

I still have that same problem in addition to another one  
 \*\*\*\*\* END EMAIL BRIEF DESCRIPTION CONTENT \*\*\*\*\*

Email states:

I had to take my truck back into the dealership Wednesday afternoon for the same thing yet again and they didn't want to give me a loner until I told them the truck was under extended warranty and this was a preexisting

condition. They called me on Thursday afternoon and said they couldn't duplicate the problem and that I needed to come get it and return the rental, as they couldn't rent it for another day. The problem still exists.

In addition, they were to repair my clutch safety switch. They fixed the switch but now when I change gears it sometimes makes a very audible noise

and I am afraid the clutch is not going to work when I need it. I have never seen a company that has so many people that don't know their job.. They can't or won't fix my truck. I truly hate to take my vehicles there. They fix one thing only to mess something else up.. I am beginning to think the lemon law would apply in this case.. Please, Can I

have someone call me so we can discuss this matter.

\*\*\*\*\*See file # 19150923 \*\*\*\*\*

ALM30 addressed the above concern for owner. NAN

Customer states that the customer just wants the vehicle to be fixed.

Customer states that the problem started with noise under the dash.

Customer alleges that the noise was fixed, but afterward the vehicle has had some electrical problems. Customer alleges that the horn will blare, the lights will flash on their own and that last night the customer was

at a dead stop when the gas gauge went to empty and the speedometer went to 70 mph then went back to normal. Customer states that the customer does not believe the dealer personnel do not know what they are doing.

Customer again mentioned considering the Lemon Law and alleges to have spoken with attorneys. Writer informed the customer that Chrysler would look into the situation and inform the customer about what can be done. Customer was advised that due to the nature of their contact a call back is required and will take place within one business day Preferred call back number is [REDACTED] (home). Customer also provided [REDACTED] (cell).

Who has possession of the vehicle? Owner  
Has the vehicle been diagnosed by a CDJ dealer? Yes  
Reassigned to 88F

\*\*\*\*\* SENIOR RESOLUTION TEAM \*\*\*\*\*

Per line 25 customer just wants the vehicle fixed. Unresolved concern can help in this situation. Writer only handles rentals, and lemon law requests. Customer did not request lemon law. Writer is going to reassign to 88F.

CONTACT UPDATE - Customer was contacted today at 9:27 am. Customer was provided with agent s extension: 66177. Customer stated that if the dealership is unable to fix the problem this time, he will not take the vehicle back. Writer informed customer unresolved concern would be sent to the dealership.

##### DIRECT-TO-DEALER #####  
ATTENTION SERVICE DIRECTOR OR SERVICE MANAGER  
Please follow your Business Center guidelines in an attempt to resolve this customers concern(s). If needed, seek assistance from your District Manager, Business Center or STAR.

The unresolved concern is electrical issues with the vehicle  
Agent called dealer and left SA Chad voice message, informed that CAIR was being sent. Please update this CAIR with resolution.

#####  
REASSIGNED TO BC/DLR 63 67879 12/24/09 09:32 R [REDACTED]

\*Contact Date:12/29/2009  
Service Manager at the dealership has updated the Cair# [REDACTED]  
An appointment has been set with the customer.

\*Contact Date:12/30/2009  
Service Manager at the dealership has closed the Cair# [REDACTED]  
Complaint could not be duplicated and explanation has been provided to customer.  
CAIR RETURNED FROM DEALER ON 12/30/2009 AT 02:15:758 R 19 [REDACTED]

---

**Customer Assistance Inquiry Record (CAIR)#** [REDACTED]

<b>VIN</b>	3D7KS28A1 8G [REDACTED]	<b>Open Date</b>	07/09/2010	<b>Built Date</b>	02/05/2008
<b>Model Year</b>	2008	<b>Body</b>	DH7L41 DODGE RAM 2500 ST QUAD CAB 4X4		
<b>In Service Dt</b>	02/23/2009	<b>Mileage</b>	40,000	<b>Dealer Zone</b>	66 ORLANDO
<b>Plant</b>	G	SALTILLO TRUCK ASSEMBLY PLANT	<b>Market</b>	U	US
<b>Color</b>	PDM	MINERAL GRAY MET. CLEAR COAT			
<b>Engine</b>	ETJ	6.7L CUMMINS TURBO DIESEL ENGINE			
<b>Transmission</b>	DEG	6-SPEED MANUAL G56 TRANSMISSION			
<b>Dealer</b>	68513	DALLAS DODGE CHRYSLER JEEP			
<b>Dealer Address</b>	1246 OLD GRIFFEN ROAD				
<b>Dealer City</b>	DALLAS	<b>Dealer State</b>	GA	<b>Dealer Zip</b>	30132
<b>Owner</b>	[REDACTED]	<b>Contact Type</b>	TELEPHONE		
<b>Address</b>	[REDACTED]	<b>Home Phone</b>			
	DALLAS GA [REDACTED]	<b>Country</b>	UNITED STATES		

Corporate - Property Damage - Default - Default - Default	
Corporate - Recall - Default - Default - Default	
Dealer - By-Pass - Default - Default - Default	
Product - Brakes - Parking Brake Assy - Other - Default	
Product - Unknown - Unknown - Accident - Default	

1. Who is calling and what is their contact information [REDACTED] calling, but can speak with Mr. or Mrs. [REDACTED]  
 Preferred: [REDACTED] Cell phone number  
 Alternate: [REDACTED] Cell phone number

2. What happened?  
 Customer alleges that vehicle was in Neutral with parking brake engaged and engine engaged when parking brake ceased to function. Customer states no one was in vehicle when accident occurred. Customer alleges that trailer and truck started to roll backward, gaining speed, went in between the houses in the culdesac, down an embankment, and into a creek at 25-35 MPH. Customer alleges that vehicle was towed out of dry creek bed. Customer alleges that property damaged occurred in an empty lot. Customer states that no one was injured. Customer alleges that there is a picture of vehicles parking brake still engaged when vehicle was towed out of embankment. Customer alleges that there was significant damage done to vehicle and property

3. What is the current location of the vehicle? [REDACTED]

Reassigned to IL502  
 Customer calls seeking recall information. Advised the customer there are no incomplete recalls for this vehicle. The customer was also advised a notification letter will be mailed to the address on file in the event their vehicle is involved in a future recall.

\*\*\*\*\*  
 VEHICLE IS LOCATED AT:  
 [REDACTED]  
 \*\*\*\*\*

Per OGC Matrix, reassigned to 82T.

7.13.10 Assigned to TNT16. MJK

CAIR NUMBER [REDACTED] REQUEST EAA INSPECTION 07-13-2010 11:25

CAIR NUMBER [REDACTED] E-MAIL SENT TO EAA 07-13-2010 11:26

CCRG Open Date: 07/13/2010 09:08:56

Letter Sent: Acknowledgement 07/14/2010 09:50:14

Customer is asking for a supervisors, customer is waiting a the investigator.Call was dropped.

Letter Sent: Denial 08/17/2010

---

**Customer Assistance Inquiry Record (CAIR)#**

[REDACTED]

<b>VIN</b>	3D7MX46A5	7G [REDACTED]	<b>Open Date</b>	07/21/2010	<b>Built Date</b>	03/30/2007
<b>Model Year</b>	2007	<b>Body</b>	D18H62	DODGE RAM SLT 4X4 3500 REG CAB		
<b>In Service Dt</b>	10/31/2007	<b>Mileage</b>	62,000	<b>Dealer Zone</b>	74	DENVER
<b>Plant</b>	G	SALTILLO TRUCK ASSEMBLY PLANT	<b>Market</b>	U	US	
<b>Color</b>	PW7	BRIGHT WHITE CLEAR COAT				
<b>Engine</b>	ETJ	6.7L CUMMINS TURBO DIESEL ENGINE				
<b>Transmission</b>	DEG	6-SPEED MANUAL G56 TRANSMISSION				
<b>Dealer</b>	67064	SPIELER'S INC				
<b>Dealer Address</b>	HIGHWAY 50 WEST					
<b>Dealer City</b>	CALIFORNIA	<b>Dealer State</b>	MO	<b>Dealer Zip</b>	65018	
<b>Owner</b>	[REDACTED]				<b>Contact Type</b>	TELEPHONE
<b>Address</b>	[REDACTED]				<b>Home Phone</b>	
	BUNCETON MO [REDACTED]				<b>Country</b>	UNITED STATES

Product - Electrical - Power/Engine Control Module - Defective - Default

Briefly summarize why the customer is contacting Chrysler: Customer s vehicle was at a construction job site and the vehicle started by itself and started to drive off. There was no one in the vehicle when this occurred but this is not the first time customer has been having problems with the vehicle. Previously, the vehicle has caught on fire while driving. Customer chose not to participate with having an attorney due to customer always gets vehicles from there dealership as in trading in the vehicle.

Briefly summarize what the customer is expecting: Customer wants something to be done to resolve the issues that are occurring. Customer was advised that due to the nature of their contact a call back is required and will take place within one business day by COB their time Preferred Morning/Midday call back number is [REDACTED] Preferred Afternoon/Evening call back number is [REDACTED] Who has possession of the vehicle? Dealer Has the vehicle been diagnosed by a CDJ dealer? Yes If a CDJ dealer has diagnosed, what is the dealer name or code? 67064 Reassigned to 88F

\*\*\*\*\* CASE MANAGER TEAM \*\*\*\*\*

Writer called dealer spoke to Justin SM, SM stated that the vehicle did start and move by itself. SM stated Tipen module is melted and this can happen. SM stated we should help customer.

CONTACT UPDATE - 1st Contact attempt, phone number dialed, [REDACTED] at 7:32. Writer left message.

Customer calls requesting to speak with KH457 Customer/Caller transferred to extension # 66386

Writer contacted dealer, SM Justin is at lunch.

Writer called dealer Justin SM self authorized.

CONTACT UPDATE - 1st Contact attempt, phone number dialed, [REDACTED] at 1:16. Writer Left message.

2nd attempt made to contact customer on 07/29/10 at 9:05.

Left message indicating another attempt will be made.

Customer was provided with agent s name and Brand number.

CLOSED LOOP UPDATE - no need for additional follow-up.

Customer called to speak with case manager.

Writer transferred to KH457.



**Customer Assistance Inquiry Record (CAIR)#** [REDACTED]

<b>VIN</b>	3D7MX48L5 9G [REDACTED]	<b>Open Date</b>	08/23/2010	<b>Built Date</b>	04/20/2009
<b>Model Year</b>	2009	<b>Body</b>	D18H42	DODGE RAM SLT 4X4 3500 QUAD CAB	
<b>In Service Dt</b>	10/23/2009	<b>Mileage</b>	9,020	<b>Dealer Zone</b>	63 DALLAS
<b>Plant</b>	G	SALTILLO TRUCK ASSEMBLY PLANT	<b>Market</b>	U	US
<b>Color</b>	PXR	BRILLIANT BLACK CRYSTAL PEARL COAT			
<b>Engine</b>	ETJ	6.7L CUMMINS TURBO DIESEL ENGINE			
<b>Transmission</b>	DEG	6-SPEED MANUAL G56 TRANSMISSION			
<b>Dealer</b>	43665	LEWIS CHRYSLER-DODGE INC			
<b>Dealer Address</b>	3311 NORTH COLLEGE AVENUE				
<b>Dealer City</b>	FAYETTEVILLE	<b>Dealer State</b>	AR	<b>Dealer Zip</b>	72703
<b>Owner</b>	[REDACTED]	<b>Contact Type</b>	TELEPHONE		
<b>Address</b>	[REDACTED]	<b>Home Phone</b>	[REDACTED]		
	WINSLOW AR [REDACTED]	<b>Country</b>	UNITED STATES		

Corporate - Property Damage - Default - Default - Default	
Dealer - By-Pass - Default - Default - Default	
Product - Transmission / Transaxle - Unknown - Jumps Out of Gear/Park - Default	
Product - Unknown - Unknown - Accident - Default	
Recall - J35: REPROGRAM ECM - REGENERATION STRATEGY - Advise Owner/Incomplete Recall	

Briefly summarize why the customer is contacting Chrysler: vehicle started in gear and ran through a fence.  
 Briefly summarize what the customer is expecting: wants to know where to go and what to do from here.

1. Who is calling and what is their contact information? [REDACTED]

Preferred [REDACTED]

2. What happened? customer attempted to start the truck with the clutch engaged and the truck started and ran through a fence

3. What is the current location of the vehicle? [REDACTED]

WINSLOW, AR [REDACTED]

Agent informed of open recall.

\*\*\*\*\*

08.24.10

>> case is being forwarded to Chrysler Legal (CCRG) (2-5 days contact)

VEHICLE LOCATED AT: RESIDENCE

MRS [REDACTED]

WINSLOW AR [REDACTED]

8.24.10 One Open Recall:

J35 REPROGRAM ECM - REGENERATION STRATEGY 04/16/2010 INCOMPLETE

8.24.10 Assigned to TNT16. MJK

CAIR NUMBER [REDACTED] REQUEST EAA INSPECTION 08-24-2010 17:00

CAIR NUMBER [REDACTED] E-MAIL SENT TO EAA 08-24-2010 17:00

Letter Sent: Acknowledgement 08/25/2010 10:21:07

PHOTOGRAPHIC IMAGES POSTED TO THIS CAIR ON 08/28/10 AT 16:08:22 19863447

Letter Sent: Denial 08/30/2010

**Customer Assistance Inquiry Record (CAIR)#**

[REDACTED]

<b>VIN</b>	1D7HA16K2 6J [REDACTED]	<b>Open Date</b>	09/04/2010	<b>Built Date</b>	06/07/2006
<b>Model Year</b>	2006	<b>Body</b>	DR1L61	DODGE RAM 1500 ST REG CAB 4X2	
<b>In Service Dt</b>	10/31/2006	<b>Mileage</b>	17,002	<b>Dealer Zone</b>	35 WASHINGTON
<b>Plant</b>	J	ST. LOUIS ASSEMBLY II - NORTH	<b>Market</b>	U	US
<b>Color</b>	PJC	LIGHT KHAKI METALLIC CLEAR COAT			
<b>Engine</b>	EKG	"MAGNUM" 3.7L V6 ENGINE			
<b>Transmission</b>	DEJ	6-SPEED MANUAL GETRAG 238 TRANS			
<b>Dealer</b>	42436	CUMBERLAND VALLEY MOTORS INC			
<b>Dealer Address</b>	6720 CARLISLE PIKE				
<b>Dealer City</b>	MECHANICSBURG	<b>Dealer State</b>	PA	<b>Dealer Zip</b>	17050
<b>Owner</b>	[REDACTED]	<b>Contact Type</b>	TELEPHONE		
<b>Address</b>	[REDACTED]	<b>Home Phone</b>	[REDACTED]		
	NEW CUMBERLAND PA [REDACTED]	<b>Country</b>	UNITED STATES		

Product - Electrical - Cruise Control - Defective - Default	Cruise control not working
Dealer - By-Pass - Default - Default - Default	Repair cost assistance

Customer called because of an issue he is having with the cruise control not working. Customer purchased the vehicle used on Aug 19th 2010 at Buchanan Auto Park Inc. Phone number [REDACTED]. Customer brought the vehicle in to have it diagnosed, however the dealership could not identify the problem. Customer is returning to the dealership on Thursday to have it looked at again. Customer stated that the problem is a clutch pedal switch. Customer would like to receive at least some assistance with these repairs and does not expect full coverage. Customer has owned 1 new and 1 used vehicle. The customer can be reached at the numbers in coin. Agent Advised customer that due to the nature of the concern his case will need to be sent to a case management team. Agent is reassigning case to 88F.

\*\*\*\*\*CASE MANAGER TEAM\*\*\*\*\*

CONTACT UPDATE - 1st Contact attempt, phone number dialed, [REDACTED] at 11:39.

Customer stated that the truck had been unable to diagnose the issue with his truck after having it for the day, but that he was able to figure out what the problem was after looking at it for 20 minutes.

Customer stated he has another appointment to have the truck looked at this Thursday and that the dealer is an hour and a half away from him. Writer advised customer that a call would be made to the Service Manager (SM) at the dealer and that I would call him back after we spoke today.

Left message with SM Tony to call back concerning customer s issue.

2nd Contact attempt, phone number dialed, [REDACTED] at 12:44.

Writer called customer and advised him that I would check back with him tomorrow after I speak with SM Tony Nell.

Customer called in asking for case manager. Writer transferred to 66020 US Customer Service - Dodge Brand Site

Brief Description:

Ref# [REDACTED]

Comments:

update please also, please read following strig of communication between dealer service and myself. The last of which they did not respond to.

[REDACTED], I have isolated the problem to the clutch switch, which is

obviously broken. It must be made to start the truck but open for the cruise to work. When a switch comes apart it stays in a closed state which allows the truck to start and run but does not allow the cruise function. I

first noticed a problem when I was able to start the truck without the clutch being depressed which could be dangerous. I currently have it rigged

to be bypassed with a toggle switch, which allows both functions as once the truck is started the circuit can be broken and the cruise function works fine. What should be the plan moving forward? Thanks, [REDACTED]

-----Original Message----- From: [REDACTED] es To:

service Sent: Wed, Aug 25, 2010 4:13 pm

Subject: Re: Service Concern Tony, Thanks, you are correct, i had gone to Chrysler s recall site and they told me this truck had 4 recalls and their records showed i was ok on all 4. I am having another issue though, the cruise doesn t work. Guess I should have thought to check it before i bought it but i never took it on the highway during the test drive

and i did not question it as the truck only has 14k mi. on it. the lights

work on the wheel and dash it just doesn t engage. The used car warranty box is checked on my paperwork, i just bought it, 8/19. Any chance it is covered? What would be the best way to proceed? thanks, [REDACTED]

-----Original Message----- From: Service

[REDACTED] Sent: Wed, Aug 25, 2010 2:39 pm

Subject: Service Concern [REDACTED], I just wanted to email you back and let you know that we did receive your email here at the

store. I also did check your vin. # through the Chrysler recall system.

I

am familiar with the recall that you mentioned, however your vehicle DOES

NOT APPLY. If you are still having a concern with a vibration in the vehicle I will be happy to check out the truck for you. Please let me know if I can be of any assistance and we will be happy to check things out

for you. Thanks [REDACTED] Nally Service Manager Buchanan Auto Park

[REDACTED] . 237 [REDACTED] fax

\*\*\*\*\* END OF CUSTOMER EMAIL \*\*\*\*\*

Dear [REDACTED]

Thank you for contacting the Chrysler Customer Assistance Center regarding your open case - Re [REDACTED].

I have updated your file with the information from your latest email.

Your Case Manager will be in contact with you as soon as possible.

Thanks again for your email.

\*\*\*\*\* END OF CAC EMAIL \*\*\*\*\*

Writer spoke with SM Tony Nally who stated that there is a part on order for the customer, but no repair has been done as of yet.

SM stated this is an issue for the used car dept for assistance rather than goodwill.

Writer advised SM I will call and speak with customer to touch base and call back if needed.

CONTACT UPDATE - Contact attempt, phone number dialed,

[REDACTED] at 11:35.

Customer was not available.

Left a message indicating another attempt would be made.

Customer called in asking for case manager. Writer transferred to 66020

Customer called trying to reach CM MM1628, writer tried ext: 66020, received VM, writer left a call back note for CM.

CONTACT UPDATE - Contact attempt, phone number dialed,

[REDACTED] at 2:33.

Customer was not available.

Left a message indicating another attempt would be made.

Customer requesting to speak with their Case Manager. Call-back note

completed and delivered to floor support for distribution to Case

Manager. Customer was ok with leavigna VM. Agent transfered to ext.

66020.

Writer spoke with SA Gary who stated that the last they heard from the customer was that he was going to schedule an appointment for further

diagnosis.

SA stated that the part has not been ordered as of yet because the truck needs to be diagnosed.

CONTACT UPDATE - Contact attempt, phone number dialed, [REDACTED] at 9:42.

Customer was not available.

Left a message indicating another attempt would be made.

Customer says the dealer is over 50 miles away. Customer says the issue is about the cruise control not working. Customer says he saw a switch on the clutch peddle is broken. Customer says the dealer has seen a problem from the switch making the vehicle surge. Customer says the dealer has not diagnosed the vehicle yet. Customer is asking for goodwill on the cost of repair. Because of the distance to the dealer customer would like to be sure the dealer will be able to fix it when he brings it in. Customer is concerned about what it will cost.

Customer requesting to speak with their Case Manager. Call-back note completed and delivered to floor support for distribution to Case Manager.

Writer contacted customer at 2:43.

Customer stated he doesn't want to make a 100 mile trip to have something diagnosed that he already knows what the issue is.

Writer advised customer he is free to go wherever to have his vehicle diagnosed.

Customer stated he would rather go to dealer 42436.

Customer stated that the switch on the clutch slave piston (clutch switch for the cruise control).

Customer stated he will be back from vacation on 10/10 and will call dealer 42436 for an appt.

Writer will follow up with dealer and customer by Monday.

Writer contacted dealer 42436 at [REDACTED] to inquire on an appointment being scheduled. Service Manager, Troy, is not available. Service Advisor, Doug, states there is an appointment scheduled. He then advised the part has just been received, so there is not an actual appointment scheduled at this time. Writer asked the SA for the diagnosis. He states the vehicle has not been diagnosed. The customer self diagnosed the vehicle and came to the dealership for the first time, wanting the repair to be covered by goodwill. SA advised the customer authorized the dealership to order the part and will pay for it. He is not sure if he is going to pay for the repair or if he is still going to request assistance from RAM. SA advised the vehicle has 17,002 miles. SA states it is his opinion the repair should not be covered by goodwill as he understands the customer has messed with wiring and bypassed it. Writer has reviewed the subsequent owner's request for assistance. There is no service contract for the vehicle to cover mechanical failures.

Although the customer has had 3 vehicles in the household, one being new and still owned, Goodwill is not merited.

The customer stated in an email documented in CAIR 19916333 on 09/08/10 and again documented on lines 35 through 46, within the current CAIR, that he has self diagnosed the vehicle and has bypassed the system to a toggle switch. It is also noted on lines 85 and 86 that the SM advised the concern is for the used car department and not goodwill.

\*\*\* GOODWILL ASSISTANCE HAS BEEN DECLINED \*\*\*

Informed customer that RAM will not participate in the repair due to vehicle modification from original manufacturer specifications which may have

contributed to the failure of the clutch switch. In addition, the vehicle warranty expired on 10/31/09.

Unless the customer offers new information, decision remains unchanged.

\*\*\*\*\*

Writer contacted the customer at [REDACTED] at 10:30 to discuss the updated information. Writer disclosed the mileage. The customer states the vehicle just turned 15,000.

Writer advised the customer RAM is unable to assist with the repair, it was suggested he contacts the selling dealership for assistance with the needed repair.

Customer accepted the information, and states he suggested that the concern should be handled by the dealership from the beginning, but he states he was told by the case manager that Chrysler will help.

Customer became upset and advised the vehicle will start without having the clutch depressed and it lurches forward. It is dangerous. He states

the vehicle should not have been sold like that.  
He feels the dealership has given the run around and false promises from Chrysler. He feels he should have called the police and the concern may have been resolved. He is disgusted with everybody but Cumberland Dodge. He advised they are willing to repair the vehicle. He will repair the vehicle and case closed. He will consider this when he goes to purchase another vehicle.

Writer advised his concerns are understood and have been documented.  
CLOSED LOOP UPDATE - no need for additional follow-up.

\*\*\* GOODWILL ASSISTANCE HAS BEEN DECLINED \*\*\*

Informed customer that RAM will not participate in the repair due to vehicle modification from original manufacturer specifications which may have

contributed to the failure of the clutch switch. In addition, the vehicle warranty expired on 10/31/09.

Unless the customer offers new information, decision remains unchanged.

\*\*\*\*\*

Writer contacted the customer at [REDACTED] at 10:30 to discuss the updated information. Writer disclosed the mileage. The customer states the vehicle just turned 15,000.

Writer advised the customer RAM is unable to assist with the repair, it was suggested he contacts the selling dealership for assistance with the needed repair.

Customer accepted the information, and states he suggested that the concern should be handled he dealership from the beginning, but he states he was told by the case manager that Chrysler will help.

Customer became upset and advised the vehicle will start without having the clutch depressed and It lunges forward. It is dangerous. He states the vehicle should not have been sold like that.

He feels the dealership has given the run around and false promises from Chrysler. He feels he should have called the police and the concern may have been resolved. He is disgusted with everybody but Cumberland Dodge. He advised they are willing to repair the vehicle. He will repair the vehicle and case closed. He will consider this when he goes to purchase another vehicle.

Writer advised his concerns are understood and have been documented.

CLOSED LOOP UPDATE - no need for additional follow-up.

---

**Customer Assistance Inquiry Record (CAIR)#**

[REDACTED]

<b>VIN</b>	1D7HA16K26J [REDACTED]	<b>Open Date</b>	09/10/2010	<b>Built Date</b>	06/07/2006
<b>Model Year</b>	2006	<b>Body</b>	DR1L61	DODGE RAM 1500 ST REG CAB 4X2	
<b>In Service Dt</b>	10/31/2006	<b>Mileage</b>	14,750	<b>Dealer Zone</b>	
<b>Plant</b>	J	ST. LOUIS ASSEMBLY II - NORTH	<b>Market</b>	U	US
<b>Color</b>	PJC	LIGHT KHAKI METALLIC CLEAR COAT			
<b>Engine</b>	EKG	"MAGNUM" 3.7L V6 ENGINE			
<b>Transmission</b>	DEJ	6-SPEED MANUAL GETRAG 238 TRANS			

<b>Owner</b>	[REDACTED]	<b>Contact Type</b>	E-MAIL
<b>Address</b>	[REDACTED]	<b>Home Phone</b>	[REDACTED]
	NEW CUMBERLAND PA [REDACTED]	<b>Country</b>	UNITED STATES

Corporate - Complaint Contact - Default - Default - Default

Case # 19906613 update

\*\*\*\*\* EMAIL BRIEF DESCRIPTION CONTENT \*\*\*\*\*

Ref# 1: [REDACTED]

\*\*\*\*\* END EMAIL BRIEF DESCRIPTION CONTENT \*\*\*\*\*

update please also, please read following strig of communication between dealer service and myself. The last of which they did not respond to.

Tony, I have isolated the problem to the clutch switch, which is obviously broken. It must be made to start the truck but open for the cruise to work. When a switch comes apart it stays in a closed state which allows the truck to start and run but does not allow the cruise function. I

first noticed a problem when I was able to start the truck without the clutch being depressed which could be dangerous. I currently have it rigged

to be bypassed with a toggle switch, which allows both functions as once the truck is started the circuit can be broken and the cruise function works fine. What should be the plan moving forward? Thanks, [REDACTED]

-----Original Message----- From [REDACTED]

service Sent: Wed, Aug 25, 2010 4:13 pm

Subject: Re: Service Concern Tony, Thanks, you are correct, i had gone to Chrysler s recall site and they told me this truck had 4 recalls and their records showed i was ok on all 4. I am having another issue though, the cruise doesn t work. Guess I should have thought to check it before i bought it but i never took it on the highway during the test drive

and i did not question it as the truck only has 14k mi. on it. the lights

work on the wheel and dash it just doesn t engage. The used car warranty box is checked on my paperwork, i just bought it,8/19. Any chance it is covered? What would be the best way to proceed? thanks, [REDACTED]

-----Original Message----- From: Service

To: bobholjes Sent: Wed, Aug 25, 2010 2:39 pm

Subject: Service Concern Hi [REDACTED], I just wanted to email you back and let you know that we did receive your email here at the

store. I also did check your vin. # through the Chrysler recall system. I

am familiar with the recall that you mentioned, however your vehicle DOES

NOT APPLY. If you are still having a concern with a vibration in the vehicle I will be happy to check out the truck for you. Please let me know if I can be of any assistance and we will be happy to check things out

for you. Thanks. Tony Nally Service Manager Buchanan Auto Park

[REDACTED] fax  
\*\*\*\*\* END OF CUSTOMER EMAIL \*\*\*\*\*

Dear [REDACTED]:

Thank you for contacting the Chrysler Customer Assistance Center regarding your open case - Ref#1 [REDACTED]

I have updated your file with the information from your latest email. Your Case Manager will be in contact with you as soon as possible.

Thanks again for your email.

\*\*\*\*\* END OF CAC EMAIL \*\*\*\*\*

\*\*\*\*\* SEE LINKED CAIR # [REDACTED] \*\*\*\*\*

---

**Customer Assistance Inquiry Record (CAIR)#** [REDACTED]

<b>VIN</b>	1D7HA18K5 6J [REDACTED]	<b>Open Date</b>	10/22/2010	<b>Built Date</b>	03/28/2006
<b>Model Year</b>	2006	<b>Body</b>	DR1L41	DODGE RAM 1500 ST QUAD CAB 4X2	
<b>In Service Dt</b>	04/30/2006	<b>Mileage</b>	49,280	<b>Dealer Zone</b>	71 LOS ANGELES
<b>Plant</b>	J	ST. LOUIS ASSEMBLY II - NORTH	<b>Market</b>	U	US
<b>Color</b>	PW7	BRIGHT WHITE CLEAR COAT			
<b>Engine</b>	EKG	"MAGNUM" 3.7L V6 ENGINE			
<b>Transmission</b>	DEJ	6-SPEED MANUAL GETRAG 238 TRANS			
<b>Dealer</b>	26550	BOB BAKER CHRYSLER JEEP			
<b>Dealer Address</b>	5555 CAR COUNTRY DR				
<b>Dealer City</b>	CARLSBAD	<b>Dealer State</b>	CA	<b>Dealer Zip</b>	92008
<b>Owner</b>	[REDACTED]	<b>Contact Type</b>	LETTER		
<b>Address</b>	[REDACTED]	<b>Home Phone</b>	[REDACTED]		
	OCEANSIDE CA [REDACTED]	<b>Country</b>	UNITED STATES		

Dealer - By-Pass - Default - Default - Default	Previous agent promise
Corporate - Reimbursement - Default - Default - Default	Reimbursement request
Product - Transmission / Transaxle - Manual Trans / Transaxle - Improper Installation/Missing - Default	Vehicles clutch switch has failed and is not covered under the csc.

\*\*\*\*Begin structured narrative T2 - Beginning Narrative

Briefly summarize why the customer is contacting Chrysler:

The customer is calling seeking to check the coverage of the customers clutch switch. Writer verified as per lop provided by the dealer 08805901 Switch, clutch/starter interlock/pedal position-Clutch/starter interlock is not a plan covered repair under the CSC. Writer forwarding the case onto 88f for possible assistance.

Briefly summarize what the customer is expecting:

The customer is seeking any assistance with the cost of the repair the customer states it is almost \$300.00 in repairs.

\*\*\*\*End structured narrative T2 - Beginning Narrative

Customer was advised that due to the nature of their contact a call back is required and will take place within one business day by COB their time Preferred Anytime call back number is [REDACTED]

Who has possession of the vehicle? Dealer

Has the vehicle been diagnosed by a CDJ dealer? Yes

If a CDJ dealer has diagnosed, what is the dealer name or code? 26550

Reassigned to 88F

\*\*\*\*\* CASE MANAGER TEAM \*\*\*\*\*

(SA) Mike stated the part was not covered under the customer s SC. (SA) stated they determined that the part was not covered because it is related to the clutch. (SA) stated the customer had never been to the dealership before.

CONTACT UPDATE - 1st Contact attempt, phone number dialed,

[REDACTED] at 2:14 pm ET.

Customer was not available.

Left a message indicating another attempt would be made.

Customer may submit for reimbursement.

As a onetime good will gesture writer will reimburse the customer for the repair with \$100.00 deductible.

Advised customer to submit original repair order & proof of payment to:

Chrysler Customer Assistance Center

[REDACTED]

██████████  
Advised customer to make a copy of these documents for their records. Asked the customer to include a brief letter of explanation & request, including their name, address, phone number, VIN, & reference number (CAIR). Advised customer the goodwill offer is dependent upon verification of all documents requested.

Writer will reimburse the customer \$241.47.

Customer paid \$341.47 for the repair.

Customer was contacted on 10/25/10 and was advised to send in documentation for reimbursement. If documentation is not received by 11/15/10 writer will follow up with customer.

CONTACT UPDATE - 1st Contact attempt, phone number dialed, ██████████ at 10:26 AM.

Customer stated that documents will be mailed as soon as customer gets the receipt. Writer explained the process and customer will understand. Documentation for reimbursement has been sent in by customer. Documents have not yet been attached to CAIR. Writer will be closing CAIR until documentation has been attached. Once attached, CAIR will be reopened and writer will process reimbursement.

POSTMARK DATE: 112910; DATE RECEIVED: 112910

Customer submitted documents for request for reimbursement for repair to the clutch switch on their vehicle, on lines 29 and 30 in this CAIR #20072049 for reimbursement in the amount of the full repair minus a \$100.00 deductible (approximately \$241.47).

Customer's proof of payment is: Debit receipt attached to dealership invoice

Date of repair: October 22nd, 2010

Labor \$102.26

Parts \$128.01

Tax \$11.20

Misc. Charges \$100.00

Total \$341.47

Minus Deductible -\$100.00

Total Reimbursement \$241.47.

Writer reviewed documents submitted by customer for reimbursement and Writer accepts copy of Debit receipt as valid proof of payment. Writer will contact customer to advise of reimbursement amount and to verify address.

The number the CSR called ██████████

CSR Spoke to and their Title: no answer, no machine.

Customer/ Dealer States: n/a

Dealer Code/or name of IRF: n/a

Writer will try again later to contact customer to verify mailing address and advise of reimbursement amount.

2nd Contact Attempt

The number the CSR called: ██████████

CSR Spoke to and their Title: Line busy

Customer/ Dealer States: n/a

Dealer Code/or name of IRF: n/a

Writer has tried twice unsuccessfully to contact customer. Writer notes that address in system matches address in documentation submitted by customer.

Writer is submitting check for approval in the amount of \$241.47

Approved.

---

**Customer Assistance Inquiry Record (CAIR)#**

[REDACTED]

<b>VIN</b>	1B7FL36N2 2S [REDACTED]	<b>Open Date</b>	12/02/2010	<b>Built Date</b>	06/08/2002
<b>Model Year</b>	2002	<b>Body</b>	AN1M61	DODGE DAKOTA P/U REGULAR CAB-SPORT 4X2	
<b>In Service Dt</b>	01/02/2003	<b>Mileage</b>	137,735	<b>Dealer Zone</b>	63 DALLAS
<b>Plant</b>	S	WARREN TRUCK ASSEMBLY PLANT 1	<b>Market</b>	U	US
<b>Color</b>	PX8	BLACK CLEAR COAT			
<b>Engine</b>	EVA	4.7L V8 MPI ENGINE			
<b>Transmission</b>	DDC	5-SPEED HD MANUAL TRANSMISSION			
<b>Dealer</b>	41067	COMMUNITY MOTORS INC			
<b>Dealer Address</b>	500 WESTIN OAKS				
<b>Dealer City</b>	HAMMOND	<b>Dealer State</b>	LA	<b>Dealer Zip</b>	70403
<b>Owner</b>	[REDACTED]	<b>Contact Type</b>	TELEPHONE		
<b>Address</b>	[REDACTED]	<b>Home Phone</b>			
	HOLDEN LA [REDACTED]	<b>Country</b>	UNITED STATES		

Product - Electrical - Lamps and Switches - Intermittent or Inoperative - Default	
Recall - D22: WINDSHIELD WIPER MODULE - Advise Owner/Incomplete Recall	

Customer called seeking recall information because interior and exterior lights do not turn on and the key is in. The vehicle will start even when the key is not turned by pressing hard on the clutch. Agent verified COIN information. Agent advised the customer of incomplete recall D22U for this vehicle. Customer was advised to contact a Dodge dealer to schedule an appointment to complete recall repair. Agent provided customer with dealership phone number. Agent advised the customer to have the vehicle diagnosed at his Dodge dealership to diagnose the vehicle.

\*\*\*\*\*END OF NARRATIVE\*\*\*\*\*

**Customer Assistance Inquiry Record (CAIR)#** [REDACTED]

<b>VIN</b>	3D7MX38AX 8G [REDACTED]	<b>Open Date</b>	12/27/2010	<b>Built Date</b>	04/11/2008
<b>Model Year</b>	2008	<b>Body</b>	D18H42 DODGE RAM 3500 SLT QUAD CAB 4X4		
<b>In Service Dt</b>	08/25/2008	<b>Mileage</b>	60,000	<b>Dealer Zone</b>	74 DENVER
<b>Plant</b>	G	SALTILLO TRUCK ASSEMBLY PLANT	<b>Market</b>	U	US
<b>Color</b>	PXR	BRILLIANT BLACK CRYSTAL PEARL COAT			
<b>Engine</b>	ETJ	6.7L CUMMINS TURBO DIESEL ENGINE			
<b>Transmission</b>	DEG	6-SPEED MANUAL G56 TRANSMISSION			
<b>Dealer</b>	44642	STEAMBOAT MOTORS, LLC			
<b>Dealer Address</b>	2310 LINCOLN AVENUE				
<b>Dealer City</b>	STEAMBOAT SPRINGS	<b>Dealer State</b>	CO	<b>Dealer Zip</b>	80487
<b>Owner</b>	[REDACTED]	<b>Contact Type</b>	TELEPHONE		
<b>Address</b>	[REDACTED]	<b>Home Phone</b>	[REDACTED]		
	OAK CREEK CO [REDACTED]	<b>Country</b>	UNITED STATES		

Product - Electrical - Power/Engine Control Module - Other - Default	power control module was smoking
Product - Electrical - Ignition System - Other - Default	starter was engaged
Corporate - Property Damage - Default - Default - Default	
Product - Unknown - Unknown - Accident - Default	

Customer called about his vehicle. Caller states that on Dec, 24th 2010 he parked his vehicle in the garage and a hour and a half later he heard his horn going off. Caller states that when he exited the vehicle the one headlight was on so he turned the light off. Caller states that when he went to the garage the vehicle s starter was engaged and the vehicle drove forward and damaged the skidoos and a heater and some other parts he had in the garage before stopping at the concrete wall. Caller states that their were skid marks on the floor. Caller states that that the control module was smoking. Customer states that he could smell wires burning. Customer states that he had Victory Motors [REDACTED] replace the power control module back in Nov. 11th 2009. Caller can be reached at cell-[REDACTED] before 9 AM or after 6:30 PM or leave a message. Caller states that he had the vehicle towed to STEAMBOAT MOTORS, LLC, Dealer Code: 44642, Deal [REDACTED] caller states that he called his insurance for vehicle and homeowners insurance also.

\*\*\*\*\* END OF CUSTOMER NARRATIVE\*\*\*

Escalating to 88S for assistance

\*\*\*\*\*END OF ESCALATING NARRATIVE\*\*\*

1. Who is calling and what is their contact information?

Preferred: - [REDACTED] before 9 AM or after 6:30 PM or leave a message

2. What happened? Please see lines 1-17.

3. What is the location of the vehicle? STEAMBOAT MOTORS LLC,

Dealer Code [REDACTED] er Phon [REDACTED]

VEHICLE IS [REDACTED]

Per OGC Matrix, reassigned to 82T.

[REDACTED] Home

Customer called wanting to know what is going on with his vehicle as it is still at the dealership and he needs to know what is going on. The above listed numbers are the best to contact customer at, trying the cell

phone first. The customer would like an update ASAP and is very upset, would like to know what Dodge/Chrysler is going to do to help him. Agent advised customer I would request that someone contact him at earliest convenience.

12.30.10 Assigned to RLG92. MJK

CAIR NUMBER [REDACTED] REQUEST EAA INSPECTION 12-30-2010 11:52

CAIR NUMBER [REDACTED] E-MAIL SENT TO EAA 12-30-2010 11:53

CCRG Open Date: 12/30/2010 08:22:20

Letter Sent: Acknowledgement 01/03/2011 13:54:21

Customer called back in seeking an update on his file. Writer apologized and advised him that a letter of acknowledgement was mailed out on 01/03/2011 but writer is unable to locate any information pertaining to this letter. Customer states his vehicle is still at the dealership.

Writer advised him to allow time to receive the letter and that should answer a lot of questions. Customer is not happy about haven t to wait for the letter. Writer apologized again and advised him that we do not have a number to transfer to legal but advised customer to please allow more time to receive the letter. Customer said he will wait for the letter.

PHOTOGRAPHIC IMAGES POSTED TO THIS CAIR ON 01/07/11 AT 14:36:43 [REDACTED]

Customer called in to find out the status of his vehicle. Advised customer that this issue was with the Special Investigation group.

The AnswerCONNECT article that was referenced to provide the answer to the

customer was # 18819

Letter Sent: Denial 01/10/2011

Owner leaves message requesting status. [REDACTED]

Per OGC Matrix, reassigned to 82T.

1.11.11 Updated Law Manager and Case Manager. MJK

Customer requesting a case manager transfered to the case manager line

[REDACTED]  
Customer is upset because he is unable to get in touch with his CM. He is upset because he cannot reach anyone to speak to regarding his case.

Writer told customer that there was no Supervisors around at the moment but if I seen one I would flag one down and have them give him a call.

Customer calling to find out status of case. Writer provided number for SI to call. Customer stated he called already and asked to be transferred to SC.

Briefly summarize why the customer is contacting Chrysler: Customer stated that vehicle should be covered by his Service Contract.

Briefly summarize what the customer is expecting:

Writer provided phone # [REDACTED] and transferred customer.

\*\*\*\*\*

Both the customer and the SM at dealer 44642 have called and left messages requesting contact regarding details of denial.

SM Brian, or Service Writer [REDACTED]

Customer [REDACTED]

Per OGC Matrix, reassigned to 82T.

1/19/11 UPDATED CCRG FILE. RLG92/LSE6

---

**Customer Assistance Inquiry Record (CAIR)#** [REDACTED]

<b>VIN</b>	1D7HA16K1 6J [REDACTED]	<b>Open Date</b>	05/28/2014	<b>Built Date</b>	04/12/2006
<b>Model Year</b>	2006	<b>Body</b>	DR1L61	DODGE RAM 1500 ST REG CAB 4X2	
<b>In Service Dt</b>	10/19/2006	<b>Mileage</b>	70,545	<b>Dealer Zone</b>	
<b>Plant</b>	J	ST. LOUIS ASSEMBLY II - NORTH	<b>Market</b>	U	US
<b>Color</b>	PBJ	ATLANTIC BLUE PEARL COAT			
<b>Engine</b>	EKG	"MAGNUM" 3.7L V6 ENGINE			
<b>Transmission</b>	DEJ	6-SPEED MANUAL GETRAG 238 TRANS			

<b>Owner</b>	[REDACTED]	<b>Contact Type</b>	E-MAIL
<b>Address</b>	[REDACTED]	<b>Home Phone</b>	
	WEST PARK FL [REDACTED]	<b>Country</b>	UNITED STATES

Corporate - CNA Change - Default - Default - Default	Updated information
Product - Drivability - Unknown - Other - Default	Vehicle starts without pressing clutch

\*\*\*\*\* EMAIL BRIEF DESCRIPTION CONTENT \*\*\*\*\*

Clutch safety switch

\*\*\*\*\* END EMAIL BRIEF DESCRIPTION CONTENT \*\*\*\*\*

My vehicle starts without pressing the clutch. Why was I never notified by Dodge/Ram etc... about this recall.

\*\*\*\*\*END OF CUSTOMER EMAIL \*\*\*\*\*

VIN: 6J [REDACTED]

Mileage: 70545

Servicing Dealer:

Title:

First Name: [REDACTED]

Address 2:

City: West Park

State: FL

Zip: [REDACTED]

Dea [REDACTED]:

Thank you for contacting the RAM Customer Assistance Center.

I regret the problem your vehicle has experienced and appreciate the time and effort you took to bring this matter to our attention.

Unfortunately, we are unable to diagnose your vehicle's problem via email. We recommend contacting your authorized dealership to arrange an appointment for proper diagnosis and repair.

Our dealerships have the factory training, equipment and information available to them to diagnose and correct problems with our vehicles. Should your dealer require technical assistance they may contact our Technical Operations Resource Group or contact their regional Business Center.

Finding a dealer is simple;

You can find a dealership by visiting our Ram brand website at Ram - [REDACTED]

Thank you again for your email. Should you require additional assistance, or have any new information to provide, please reply to this email message or call [REDACTED]

Sincerely,

Melissa

Customer Service Representative

RAM Customer Assistance Center

\*\*\*\*\*END OF CAC EMAIL\*\*\*\*\*

Is the repair going to be free of charge

\*\*\*\*\*END OF CUSTOMER EMAIL\*\*\*\*\*

Dear [REDACTED]

Thank you for contacting the RAM Customer Assistance Center.

In regards to your vehicle, we fully appreciate your concern, particularly in view of the expense and inconvenience involved, however, we are unable to accommodate your request for out-of-warranty consideration. The vehicle has exceeded the time and/or mileage limitations of the warranty (or warranties) we offered on the vehicle at the time it was purchased. Although we are unable to provide a more favorable reply, we appreciate the opportunity to review your request. We re sorry we cannot provide a more favorable reply.

Thank you again for your email. Should you require additional assistance, or have any new information to provide, please reply to this email message or cal [REDACTED]).

Sincerely,

[REDACTED]  
Customer Service Representative  
RAM Customer Assistance Center

\*\*\*\*\*END OF CAC EMAIL\*\*\*\*\*

---

PE14-013

CHRYSLER

8-11-2014

ENCLOSURE 6

Field Reports PUBLIC

CUSTOMER COMPLAINTS

PEER VEHICLE REPORTS

JEEP

CAIR

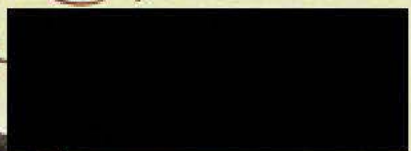

6.23.99

6 23 '99

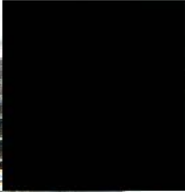

6.23.99





8 23 '99



8 23 '98

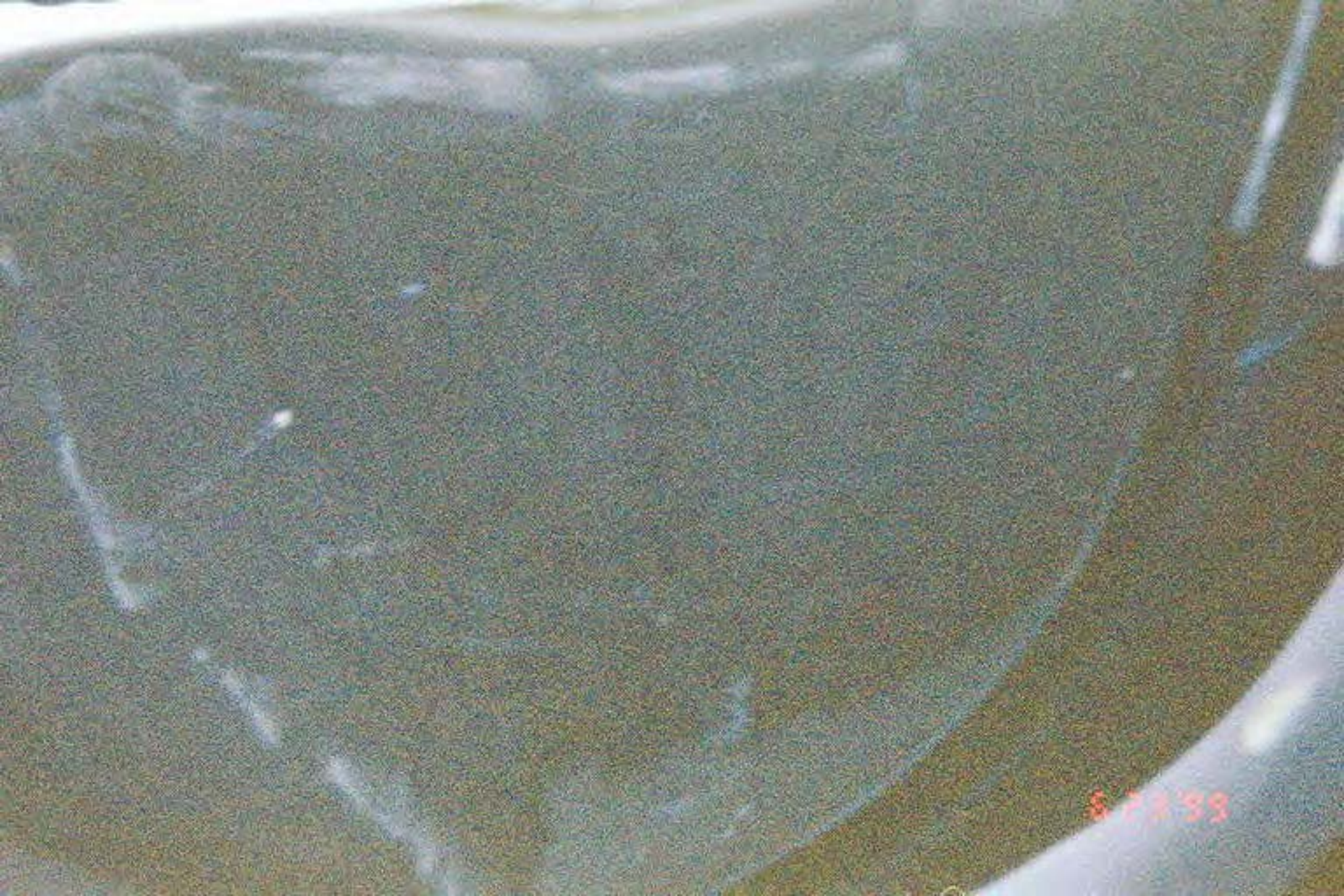

6.23.99





6.23 '99





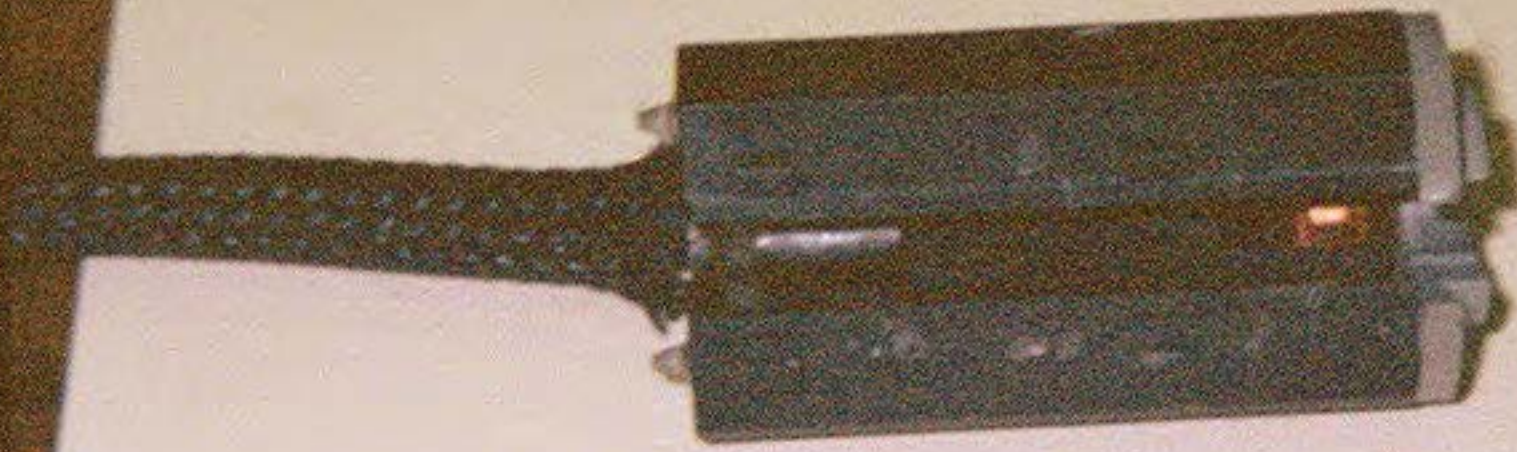

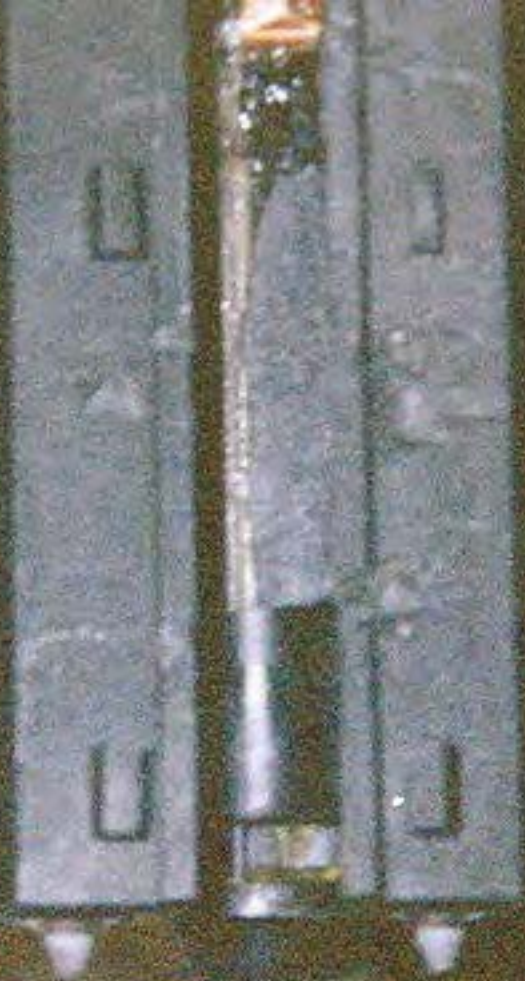

6 23 '99



5 23 '99







PLEASE RESUME FAXING REPORTS TO THE NEW DAIMLERCHRYSLER FAX #313-369-7306. IF YOU EXPERIENCE ANY DIFFICULTIES PLEASE CONTACT ME BY PHONE OR FAX. THANK YOU!

Facsimile Cover Sheet DaimlerChrysler Vehicle Investigation Report (VIR)

Owner: [redacted]
EAA No: [redacted]
CAIR No: [redacted]

Transmitting 2 pages. If transmission not complete, please call the above phone number.

To: [redacted]
PH: [redacted]
Fa: [redacted]

From: Tina Martin
Date Faxed: 6-22
Due Date: 6-25

Please acknowledge promptly by FAX or phone.

Receipt of CAIR and Accepting case for investigation YES NO DATE 6-22-99

Fax Coversheet for DaimlerChrysler (Service Associate Use Only) (also fax to EAA for closure)

Date: 6-24-99 Fax Number: 313-369-7306

Number of pages (incl. Cover) 6

- TO: [Bennis (248) 944-7036, Bott (248) 944-7056, Gilbert (248) 944-7037, Martell (248) 944-7038, Mucci (248) 944-7039, Porterfield (248) 944-7134]

Comments:



# Confidential Preliminary Vehicle Investigation Report

REF. # [REDACTED]

YEAR 99	MODEL Dodge 3500 Ram	VEHICLE IDENTIFICATION NUMBER 3B7MF366XIM [REDACTED]	ODOMETER 1517	M.D.M. [REDACTED]	DELIVERY DATE 5/26/99
NAME OF OWNER [REDACTED]		ADDRESS/LOCATION [REDACTED]			
STATE AR		ZIP [REDACTED]	BUSINESS PHONE ( ) [REDACTED]	HOME PHONE ( ) [REDACTED]	
SELLING DEALER NAME Davis Motor Co		ZONE 61113151611	CITY Clinton	STATE AR	
CHRYSLER REPRESENTATIVE - PRINT Curtis Patton EA		ZONE Memphis	PHONE [REDACTED]	MINOR MODERATE MAJOR [REDACTED]	

### INTERVIEW

INTERVIEW WITH: <input checked="" type="checkbox"/> DRIVER <input type="checkbox"/> OWNER <input type="checkbox"/> OTHER	NAME [REDACTED]	INTERVIEW DATE 6/23/99	DATE OF INCIDENT 6/15/99	TIME OF INCIDENT approx 1:30 PM	INSPECTION DATE 6/23/99
---	--------------------	---------------------------	-----------------------------	------------------------------------	----------------------------

DESCRIPTION OF EVENT: (INCLUDING WEATHER CONDITIONS AND ROAD SURFACE)  
 Vehicle parked.

Driver's and/or occupant's description of incident  
 I had opened left door and reached into vehicle to turn on the ignition.

What? When? Where? How?  
 Vehicle was hot inside and I wanted to roll windows down. When I accidentally

Exact order of events  
 turned ignition switch to crank position the engine started and transmission

Did this happen before?  
 was in gear. The vehicle moved forward into building damaging bumper & grille

Personal Injury: Were there Personal Injuries?  Yes  No If yes, complete section "L."

### IMPORTANT: SHOW TO NO ONE & DRAW NO CONCLUSIONS

**DIRECTIONS:** FILL OUT UPPER PART OF FORM.  
 FOR "FIRE" USE FORM 84-130-6950.  
 FOLLOW INSTRUCTIONS FOR SECTION "A" ON ALL VEHICLES.  
 FOLLOW INSTRUCTIONS FOR SPECIFIC ALLEGATIONS FOR THIS VEHICLE.  
 ATTACH ANY ADDENDUMS TO REPORT AND STATE SECTION IT PERTAINS TO.

**COMMENTS:** • NOTE ANY MISSING COMPONENTS AND WHO REMOVED THEM.  
 • NOTE ANY AFTERMARKET EQUIPMENT INSTALLED AND BY WHOM.

ALLEG.	PHOTOGRAPH REQUIRED	INFORMATION	EVALUATION	
<b>A</b>	<input checked="" type="checkbox"/> From center of vehicle front every 45 degree (8 total) <input checked="" type="checkbox"/> If crash damaged — perspective from every corner of vehicle down both original lateral sight lines. (8 total)  <input type="checkbox"/> Send neg. & 2 sets of prints	<input checked="" type="checkbox"/> Police report none <input checked="" type="checkbox"/> Vehicle service file <input checked="" type="checkbox"/> Any reports/photos by others <input checked="" type="checkbox"/> Location of inspection	<input checked="" type="checkbox"/> Driver's and/or occupant's description of incident <input checked="" type="checkbox"/> What? When? Where? How? <input checked="" type="checkbox"/> Exact order of events <input checked="" type="checkbox"/> Did this happen before?	<input checked="" type="checkbox"/> Complete exterior damage diagram and measurements on last page.

<b>B</b>	<input type="checkbox"/> Steering Wheel <input type="checkbox"/> Airbag(s) <input type="checkbox"/> Knee Blockers <input type="checkbox"/> All possible body contact areas <input type="checkbox"/> All code readings using DRB II	<input type="checkbox"/> Record: <input type="checkbox"/> Was Airbag deployed? Driver <input type="checkbox"/> Yes <input type="checkbox"/> No Passenger <input type="checkbox"/> Yes <input type="checkbox"/> No <input type="checkbox"/> Type of Steering Wheel <input type="checkbox"/> Tilt <input type="checkbox"/> Std. <input type="checkbox"/> Condition of Steering Wheel _____ <input type="checkbox"/> Condition of Steering Wheel Mounting (measure column collapse) _____	<input type="checkbox"/> Evidence of tampering or disassembly? <input type="checkbox"/> Yes <input type="checkbox"/> No <input type="checkbox"/> Use DRB II <input type="checkbox"/> Record Existing Readings 1 _____ 2 _____ <input type="checkbox"/> Record Stored Readings 1 _____ 2 _____ 3 _____ <input type="checkbox"/> Important: DO NOT ERASE DRB II READINGS.
----------	--	---	--

ALLEG. PHOTOGRAPH REQUIRED INFORMATION EVALUATION

Sudden Acceleration or Throttle Hold

- Accelerator Pedal
Throttle Cable
Return Springs
Floor Mats

Describe any Accelerator Pedal interference with Carpet/Mat

DOES NOT APPLY TO THIS SITUATION

- DRB II Tests
Disconnect Cable at Throttle Body/Carburetor lever; operate:
Lever Cable
Any restricted motion?
Yes No
If safe and permitted to drive - attempt to duplicate and check Service Brakes at reported speed.

C

Brakes

Items in Information Block.

- Check and record Brake Fluid Level.
Check and record if Vacuum Hose is connected. Yes No
Check and record for Brake Line Leaks. Yes No
Pull Wheels, check Linings and record condition.
Check Brake Pedal, does it set firm? Yes No
Check operation of Parking Brake.
Check operation of ABS System.

- With Engine off:
Apply Brake fully 3 or 4 times.
With light force held to Pedal, start the Engine.
Note reaction of Pedal and record:
ABS System DRB II test results

D

Steering

- Complete Steering System Including as required:
Rack & Pinion
Linkage
CV & Universal Joints
Column
Belts & Pulleys

- Record if:
Manual Steering Power Steering
Check Fluid Level
Record if Drive Belt is tight Yes No
Check for Hose/System leaks Yes No Leaks
Check condition of Steering Linkage from Wheels to Steering Column, record deformation or loose connections.

- Unlock key and turn Wheels fully right and left.
If safe, start Engine and turn Wheels fully right and left.
Record Steering function.

E

Transmission

Entire Transmission with pictures and closeup of leaks, if any.

- Record:
Type of Transmission?
Auto Std.
How many Speeds? 3 4 5 with 4 wheel drive.
Record Gear Shift location at time of inspection
Run Shift Lever thru all shift positions and record "Feel of Gating"
Is Shift Indicator properly aligned? Yes No

- If safe and permitted to drive vehicle:
Drive Vehicle and record feel of Gear during each Gear Shift
Does Parking Pawl engage? Yes No
If lockup is alleged - check rotation of Transmission in all Gears.
Check starting ability in park or 1 neutral. Check to see that start does not occur in other selector positions.

F

Engine Stall/Drivability

- Complete Engine Compartment Including as required:
Underhood Emissions Label
Engine Wiring/Connections
Vacuum Hoses
Fuel Lines
Exhaust System
Spark Plugs
Connections

Record type of Spark Plugs (location of unique plugs).

- If safe and permitted to:
Try to duplicate Allegation Off Highway
DRB II or I/P Fault Code Test

G

### Confidential

REF. #

ALLEG. PHOTOGRAPH REQUIRED INFORMATION EVALUATION

Seat/Shoulder Belts

H

- Overall of seat belts I/B and O/B.
- Close ups of any irregularities on belts.
- Shoulder Belt Pendulum
- Latchplate wear
- Close up of D-ring to show belt loading.

- Locate seat belt labels and record ALL information (Some labels are sewn to webbing, other labels are on retractor frame. Inboard seat belt labels are near floor.)

- Record ALL information stamped on latchplate.

If allowed, function belts to insure they FUNCTION PROPERLY, note results:

- Do they latch?  Yes  No
- Do they release?  Yes  No
- Do they retract?  Yes  No
- Does Inertia Pendulum System run freely?  Yes  No

Seat

I

- Overall of seat
- Close ups of damage

- Existing location of recliner - number of teeth from rear of sector gear to rear edge of Pawl (crayon mark location).

- Existing location of seat adjuster (window or tooth location from rear of adjuster).

- Existing location of head restraint (measure gap under head restraint).

- If allowed, adjust all functions of seat and return to original location

- Describe functions

- Note any irregular orientations

Tires

J

- Each Tire with visible location label, insuring all Tire identification and Tread wear is documented.
- All damaged Wheel and Rim area including impacted foreign material.

Record:

- Tire Size
- Brand
- Ratings
- DOT No. (I/B Side)
- Rim Size
- Tread Depth

	Front Left	Front Right	Rear Left	Rear Right

Axle Lockup

K

- Entire Axle and close up of Leaks

While on hoist:

- Rear Wheel Drive Record amount of Lateral Axle Movement on each side and will Wheels turn

- Trans. Axle - rotate Wheels
- Note function

Occupant Contact

L

- Windshield
- All areas of occupant contact on Interior and exterior.
- Close ups of stains, skin, hair, cloth
- Exterior and interior damage

- See Seat Belt/Seats if applicable
- Occupant contact description

#### ADDITIONAL COMMENTS

Drivers concerns could not be duplicated. The design of clutch safety switch renders it near impossible for the condition to exist that would allow the engine to start. Even though the driver said he could produce witnesses to verify what happened, it appears the true facts of what caused the vehicle to move forward has not surfaced. The dealer had special ordered new clutch switch and installed it before I left the dealership. This is mocho truck, 3500 series Ram dually with 5 speed transmission with 4 wheel drive. with 6cyl cummings diesel. This truck is definately not for everyone.

**Exterior Damage Diagram and Measurements**

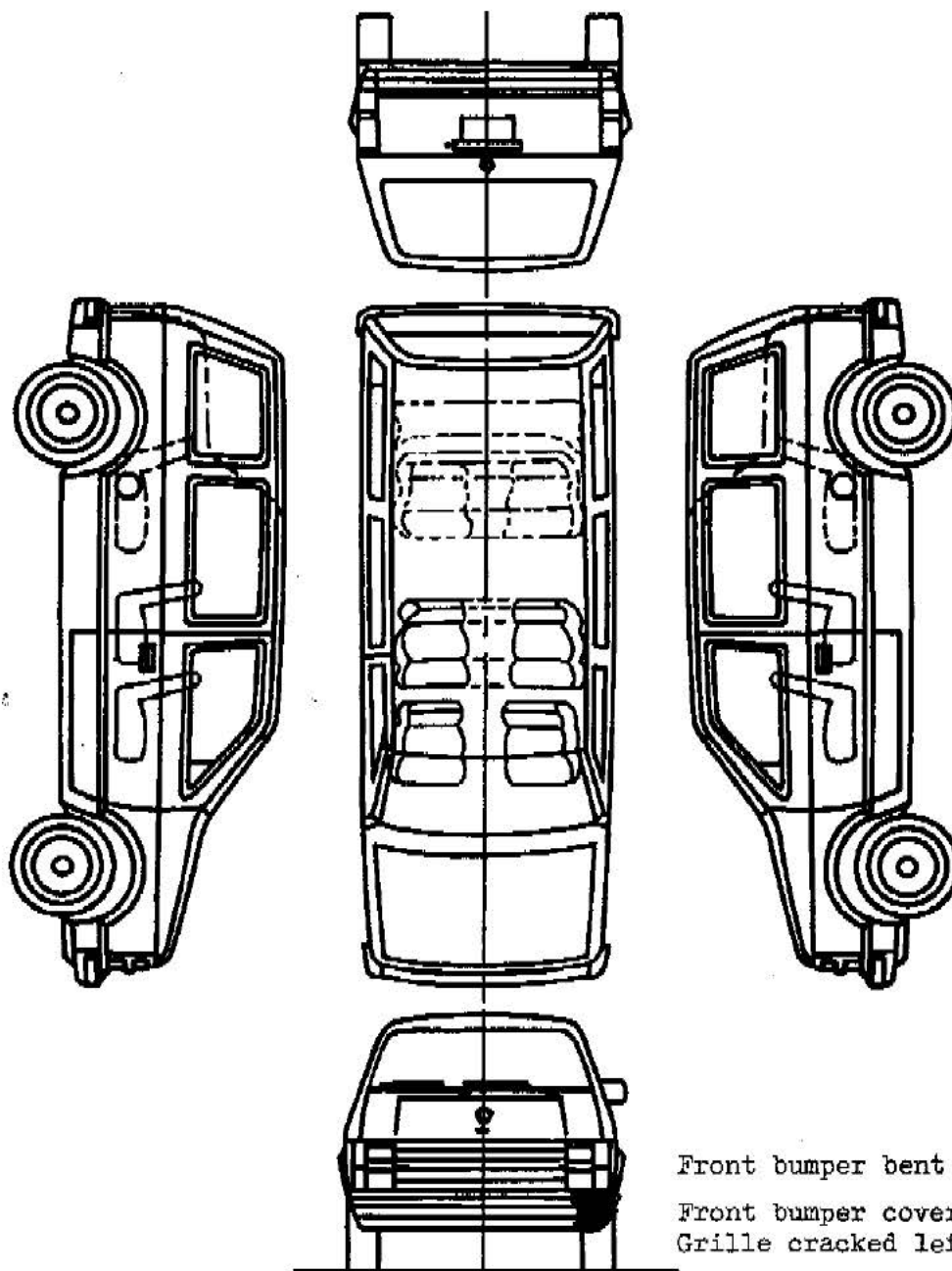

Front bumper bent back 1 1/2 "  
 Front bumper cover torn loose  
 Grille cracked left side 2"

**Sketch damage on all views. Include dimensions to describe and locate each damaged area and maximum depth of penetration for each impact. Annotate observations which might be useful in reconstructing the accident (e.g., direction of scrapes, markings on tires and wheels, etc.). Take photographs.**

~~1035~~  
miles  
1517

File Terminal Goto Find Information PartInfo Image Review List Help  
USER ID: TRAN CATALOG: "97-99 BR" GRP: 6 PARTS TRN: SACTION:

SELECTED PARTS INFORMATION													
PART	PART NAME	QTY	RTH	SYM	PARTTYPE	NIN	CHG	UNIT/M	LIST	DEALER	WHL SL	FLEET	STKORD
* 55076 599RD	BUMPER	001	E	B	23-34-4	001			305.00	183.00			123.85
* 55076 614AD	PANEL	001	E	B	23-34-7	001			97.00	58.00			55.10
* 55076 610	FASCIA	001	E	B	23-34-7	001			71.50	42.75			40.61
* 55076 350	GRILLE	001	E	B	23-33-41	001			245.00	147.00			139.65
* 53007 944AD	SWITCH	001	E	B	8-58-60	001			63.00	37.75			35.86

==== END OF LIST =====

476.50 PARTS  
30.92 TAX  
507.47  
93.00 LABOR  
\$600.47 TOTAL

Flashing line indicates history for this part  
Press ENTER to exit

F1 Inv	F2 NoIn	F3 Catx	F4 Grpx	F5 I11x	F6 Name	F7 Numx	F8 Cat Info	F9 Find	F10 Hist	F11 All	F12 Ins/text	CF1 Zoom	CF2 Note	CF3 Help	CF4 View List	CF5 Memo	CF6 VIN	CF7 List Util	CF8 View Vin	CF9 Add Part	CF10 Qty	CF11 Rt.	CF12 Chrt C
--------	---------	---------	---------	---------	---------	---------	-------------	---------	----------	---------	--------------	----------	----------	----------	---------------	----------	---------	---------------	--------------	--------------	----------	----------	-------------

1.4 hr. Bumper,  
.7 hr. Lower Cover,  
.7 hr. upper Cover,  
.3 hr. Grill.

labor 30.00 per hr.

3.1 hr. 93.00

PE14-013

CHRYSLER

8-11-2014

ENCLOSURE 6

Field Reports PUBLIC

CUSTOMER COMPLAINTS

PEER VEHICLE REPORTS

[REDACTED]



[REDACTED]

UNITED STATES POSTAL SERVICE  
FIRST CLASS PERMIT NO. 1000 NEW YORK, NY 10108

TO	FROM	WEIGHT	POSTAGE	INSURANCE
1000	1000	1.00	0.00	0.00
1000	1000	1.00	0.00	0.00
1000	1000	1.00	0.00	0.00
1000	1000	1.00	0.00	0.00



















140 190 240

18 1 2 3 4

DIESEL FUEL ONLY

RPM X 1000

22166



166



ENGINEERING ANALYSIS ASSOCIATES, INC.

PLEASE RESUME FAXING REPORTS TO THE NEW DAIMLERCHRYSLER FAX #313-369-7306. IF YOU EXPERIENCE ANY DIFFICULTIES PLEASE CONTACT ME BY PHONE OR FAX. THANK YOU!

Facsimile Cover Sheet DaimlerChrysler Vehicle Investigation Report (VIR)

Owner: [redacted]
EAA No: D [redacted]
CAIR No: [redacted]

Transmitting 27/30 pages. If transmission not complete, please call the above phone number.

To: [redacted]
Phone: [redacted]
Fax: [redacted]

From: Tina Martin
Date Faxed: 7/30
Due Date: 8/4

Please acknowledge promptly by FAX or phone.
Receipt of CAIR and Accepting case for investigation YES NO DATE 8-2

Fax Coversheet for DaimlerChrysler (Service Associate Use Only)
Date: 8-4-99 Fax Number: 313-369-7306
Number of pages (incl. Cover) 7
TO:
Bennis (248) 944-7036
Bott (248) 944-7056
Gilbert (248) 944-7037
Martell (248) 944-7038
Mucci (248) 944-7039
Porterfield (248) 944-7134
Comments:



**Confidential**  
**Preliminary Vehicle Investigation Report**

REF. # [REDACTED]

YEAR 98	MODEL RAM 2500	VEHICLE IDENTIFICATION NUMBER 1 B 7 R C 2 3 6 3 W J [REDACTED]	ODOMETER 0 2 2 1 6 6	M.I.H. [REDACTED]	DELIVERY DATE 9/19/98
[REDACTED]		ADDRESS [REDACTED]	[REDACTED]		
[REDACTED]		STATE LA	[REDACTED]		
[REDACTED]		ZONE 65	DUR. CODE 4 4 1 0 7	CITY [REDACTED]	STATE LA
CHRYSLER REPRESENTATIVE — PRINT BEN LOVE - ENGINEERING ANALYSIS ASSO		ZONE NEW ORLEANS	PHONE [REDACTED]	MINOR MODERATE MAJOR	REPAIR ESTIMATE \$ 2837.68

**INTERVIEW**

INTERVIEW WITH: <input type="checkbox"/> DRIVER <input checked="" type="checkbox"/> OWNER <input type="checkbox"/> OTHER	NAME MR SUTTON	INTERVIEW DATE 0 8   0 4   9 9	DATE OF INCIDENT 0 7   2 9   9 9	TIME OF INCIDENT 12 :05 AM PM	INSPECTION DATE 0 8   0 3   9 9
---	-------------------	-----------------------------------	-------------------------------------	--	------------------------------------

DESCRIPTION OF EVENT (INCLUDING WEATHER CONDITIONS AND ROAD SURFACE)  
MR [REDACTED] STATED THAT HIS HELPER AND HE WERE GETTING READY TO GO TO LUNCH AND HIS HELPER WAS IN THE TRUCK ON THE PASSENGER SIDE. AS HE APPROACHED THE TRUCK TO GET INTO THE DRIVERS DOOR HIS HELPER REACHED ACROSS AND TURNED THE IGNITION SWITCH TO THE ON POSITION AND THE TRUCK STATED. IT WAS IN 2nd GEAR AT THE TIME AND IT PROCEEDED FORWARD AND STRUCK A 1000 GAL. PROPANE TANK AND RAN INTO A 750 GAL. WATER TANK AND STOPPED.

Personal Injury: Were there Personal Injuries?  Yes  No If yes, complete section "L."

**IMPORTANT: SHOW TO NO ONE & DRAW NO CONCLUSIONS**

- DIRECTIONS:**
- FILL OUT UPPER PART OF FORM.
  - FOR "FIRE" USE FORM 84-130-8850.
  - FOLLOW INSTRUCTIONS FOR SECTION "A" ON ALL VEHICLES.
  - FOLLOW INSTRUCTIONS FOR SPECIFIC ALLEGATIONS FOR THIS VEHICLE.
  - ATTACH ANY ADDENDUMS TO REPORT AND STATE SECTION IT PERTAINS TO.

- COMMENTS:**
- NOTE ANY MISSING COMPONENTS AND WHO REMOVED THEM.
  - NOTE ANY AFTERMARKET EQUIPMENT INSTALLED AND BY WHOM.

ALLEG.	PHOTOGRAPH REQUIRED	INFORMATION	EVALUATION
<b>A</b>	<input checked="" type="checkbox"/> From center of vehicle front every 45 degrees (8 total) <input checked="" type="checkbox"/> If crash damaged — perspective from every corner of vehicle down both original lateral sight lines. (8 total)  <input checked="" type="checkbox"/> Send neg. & 2 sets of prints	<input checked="" type="checkbox"/> Police report <input checked="" type="checkbox"/> Vehicle service file <input checked="" type="checkbox"/> Any reports/photos by others <input checked="" type="checkbox"/> Location of inspection ACADIANA DODGE 1700 SE EVANGELINE THRUWAY LAFAYETTE, LA	<input checked="" type="checkbox"/> Driver's and/or occupant's description of incident <input checked="" type="checkbox"/> What? When? Where? How? <input checked="" type="checkbox"/> Exact order of events <input checked="" type="checkbox"/> Did this happen before? <input checked="" type="checkbox"/> Complete exterior damage diagram and measurements on last page.
	<b>B</b>	<input type="checkbox"/> Steering Wheel <input type="checkbox"/> Airbag(s) <input type="checkbox"/> Knee Blockers <input type="checkbox"/> All possible body contact areas <input type="checkbox"/> All code readings using DRB II	<input type="checkbox"/> Record: <input type="checkbox"/> Was Airbag deployed? Driver <input type="checkbox"/> Yes <input type="checkbox"/> No Passenger <input type="checkbox"/> Yes <input type="checkbox"/> No <input type="checkbox"/> Type of Steering Wheel <input type="checkbox"/> TR <input type="checkbox"/> Std. <input type="checkbox"/> Condition of Steering Wheel <input type="checkbox"/> Condition of Steering Wheel Mounting (measure column collapse)

Confidential

REF. [REDACTED]

ALLEG.	PHOTOGRAPH REQUIRED	INFORMATION	EVALUATION
<b>C</b> Sudden Acceleration or Throttle Hold	<input type="checkbox"/> Accelerator Pedal <input type="checkbox"/> Throttle Cable <input type="checkbox"/> Return Springs <input type="checkbox"/> Floor Mats	<input type="checkbox"/> Describe any Accelerator Pedal Interference with Carpet/Mat <hr/> <hr/> <hr/> <hr/> <hr/> <hr/>	<input type="checkbox"/> DRB II Tests <input type="checkbox"/> Disconnect Cable at Throttle Body/Carburetor lever; operate: <input type="checkbox"/> Lever <input type="checkbox"/> Cable <input type="checkbox"/> Any restricted motion? <input type="checkbox"/> Yes <input type="checkbox"/> No <input type="checkbox"/> If safe and permitted to drive - attempt to duplicate and check Service Brakes at reported speed.
<b>D</b> Brakes	<input type="checkbox"/> Items in Information Block.	<input type="checkbox"/> Check and record Brake Fluid Level. _____ <input type="checkbox"/> Check and record if Vacuum Hose is connected. <input type="checkbox"/> Yes <input type="checkbox"/> No <input type="checkbox"/> Check and record for Brake Line Leaks. <input type="checkbox"/> Yes <input type="checkbox"/> No <input type="checkbox"/> Pull Wheels, check Linings and record condition. <hr/> <input type="checkbox"/> Check Brake Pedal, does it set firm? <input type="checkbox"/> Yes <input type="checkbox"/> No <input type="checkbox"/> Check operation of Parking Brake. <input type="checkbox"/> Check operation of ABS System.	With Engine off: <input type="checkbox"/> Apply Brake fully 3 or 4 times. <input type="checkbox"/> With light force held to Pedal, start the Engine. <input type="checkbox"/> Note reaction of Pedal and record: <hr/> <hr/> <input type="checkbox"/> ABS System DRB II test readouts <hr/> <hr/>
<b>E</b> Steering	<input type="checkbox"/> Complete Steering System including as required: • Rack & Pinion • Linkage • CV & Universal Joints • Column • Belts & Pulleys	<input type="checkbox"/> Record if: <input type="checkbox"/> Manual Steering <input type="checkbox"/> Power Steering <input type="checkbox"/> Check Fluid Level _____ <input type="checkbox"/> Record if Drive Belts tight <input type="checkbox"/> Yes <input type="checkbox"/> No <input type="checkbox"/> Check for Hose/System leaks <input type="checkbox"/> Yes <input type="checkbox"/> No Leaks <input type="checkbox"/> Check condition of Steering Linkage from Wheels to Steering Column, record deformation or loose connections. <hr/> <hr/> <hr/>	<input type="checkbox"/> Unlock key and turn Wheels fully right and left. <input type="checkbox"/> If safe, start Engine and turn Wheels fully right and left. <input type="checkbox"/> Record Steering function.
<b>F</b> Transmission	<input checked="" type="checkbox"/> Entire Transmission with pictures and closeup of leaks, if any.  5-sp STANDARD TRANS.  NO DRB INFORMATION FOR TRANS AVAILABLE  NO ENGINE DTC's DETECTED STARTS SINCE CLEARED =255	<input checked="" type="checkbox"/> Record: Type of Transmission? <input type="checkbox"/> Auto <input checked="" type="checkbox"/> Std. How many Speeds? <input type="checkbox"/> 3 <input type="checkbox"/> 4 <input checked="" type="checkbox"/> 5 <input checked="" type="checkbox"/> Record Gear Shift location at time of inspection <u>NEUTRAL WITH THE PARKING BRAKE SET</u> <hr/> <input checked="" type="checkbox"/> Run Shift Lever thru all shift positions and record "Feel of Clating" <u>TRANS GEAR SHIFT ENGAGES ALL GEAR POSITIONS SOLIDLY</u> <hr/> <input checked="" type="checkbox"/> Is Shift Indicator properly aligned? <input checked="" type="checkbox"/> Yes <input type="checkbox"/> No	If safe and permitted to drive vehicle: <input checked="" type="checkbox"/> Drive Vehicle and record feel of Gear during each Gear Shift <u>UNIT SHIFTS IN &amp; OUT OF ALL GEARS PROPERLY. VEH WILL NOT START IN ANY GEAR WITHOUT CLUTCH PEDAL FULLY DEPRESSED</u> <input checked="" type="checkbox"/> Does Parking Pawl engage? <input type="checkbox"/> Yes <input type="checkbox"/> No <input type="checkbox"/> If lockup is alleged - check rotation of Transmission in all Gears. <input checked="" type="checkbox"/> Check starting ability in park and neutral. Check to see that start does not occur in other selector positions.
<b>G</b> Engine Start/Driveability	<input type="checkbox"/> Complete Engine Compartment including as required: • Underhood Emissions Label • Engine Wiring/Connections • Vacuum Hoses • Fuel Lines • Exhaust System • Spark Plugs • Connectors	<input type="checkbox"/> Record type of Spark Plugs (location of unique plugs). <hr/> <hr/> <hr/> <hr/> <hr/> <hr/>	If safe and permitted to: <input type="checkbox"/> Try to duplicate Allegation Off Hwy <input type="checkbox"/> DRB II or VP Fault Code Test <hr/> <hr/> <hr/> <hr/> <hr/>

\*\*\*\*\* NEUTRAL SAFETY SWITCH IS PROPERLY ALIGNED AND FUNCTIONAL \*\*\*\*\*

Confidential

REF. #

ALLEG.	PHOTOGRAPH REQUIRED	INFORMATION	EVALUATION																								
H Seat/Shoulder Belts	<input type="checkbox"/> Overall of seat belts I/B and O/B <input type="checkbox"/> Close ups of any irregularities on belts. <input type="checkbox"/> Shoulder Belt Pendulum <input type="checkbox"/> Latchplate wear <input type="checkbox"/> Close up of D-ring to show belt loading.	<input type="checkbox"/> Locate seat belt labels and record ALL information (Some labels are sewn to webbing, other labels are on retractor frame. Inboard seat belt labels are near floor.) <input type="checkbox"/> Record ALL information stamped on latchplate.	If allowed, function belts to insure they FUNCTION PROPERLY, note results: Do they latch? <input type="checkbox"/> Yes <input type="checkbox"/> No Do they release? <input type="checkbox"/> Yes <input type="checkbox"/> No Do they retract? <input type="checkbox"/> Yes <input type="checkbox"/> No <input type="checkbox"/> Does Inertia Pendulum System run freely? <input type="checkbox"/> Yes <input type="checkbox"/> No																								
			Seat <input type="checkbox"/> Overall of seat <input type="checkbox"/> Close ups of damage	<input type="checkbox"/> Existing location of recliner - number of teeth from rear of sector gear to rear edge of Pawl (crayon mark location). <input type="checkbox"/> Existing location of seat adjuster (window or tooth location from rear of adjuster). <input type="checkbox"/> Existing location of head restraint (measure gap under head restraint).	<input type="checkbox"/> If allowed, adjust all functions of seat and return to original location <input type="checkbox"/> Describe functions <input type="checkbox"/> Note any irregular orientations																						
J Tires	<input type="checkbox"/> Each Tire with visible location label, insuring all Tire identification and Tread wear is documented. <input type="checkbox"/> All damaged Wheel and Rim area including impacted foreign material.	Record: <input type="checkbox"/> Tire Size <input type="checkbox"/> Brand <input type="checkbox"/> Ratings <input type="checkbox"/> DOT No. (I/B Side) <input type="checkbox"/> Rim Size <input type="checkbox"/> Tread Depth	<table border="1"> <thead> <tr> <th>Front Left</th> <th>Front Right</th> <th>Rear Left</th> <th>Rear Right</th> </tr> </thead> <tbody> <tr><td> </td><td> </td><td> </td><td> </td></tr> <tr><td> </td><td> </td><td> </td><td> </td></tr> <tr><td> </td><td> </td><td> </td><td> </td></tr> <tr><td> </td><td> </td><td> </td><td> </td></tr> <tr><td> </td><td> </td><td> </td><td> </td></tr> </tbody> </table>	Front Left	Front Right	Rear Left	Rear Right																				
			Front Left	Front Right	Rear Left	Rear Right																					
Axle Lookup <input type="checkbox"/> Entire Axle and close up of Leaks	While on hoist: <input type="checkbox"/> Rear Wheel Drive Record amount of Lateral Axle Movement on each side and will Wheels turn <input type="checkbox"/> Trans. Axle - rotate Wheels <input type="checkbox"/> Note function	K <input type="checkbox"/> Windshield <input type="checkbox"/> All areas of occupant contact on interior and exterior. <input type="checkbox"/> Close ups of stains, skin, hair, cloth <input type="checkbox"/> Exterior and interior damage	<input type="checkbox"/> See Seat Belts/Seats if applicable <input type="checkbox"/> Occupant contact description																								

ADDITIONAL COMMENTS

NOTE: AIRBAG STORED DTC's =1, "CLUSTER MESSAGE MISMATCH", MIN=3, IGN CNTS=10

VEHICLE ENGINE WOULD NOT TURN OVER AND START DURING INSPECTION UNLESS THE CLUTCH PEDAL WAS FULLY DEPRESSED TO THE FLOOR. THE NEUTRAL SAFETY SWITCH WAS PROPERLY ADJUSTED AND DID NOT SHOW ANY SIGNS OF BEING TAMPERED WITH.

REFERANCE: DEALERS REPAIR ORDER FOR INSPECTION AND REPAIR IS RO#75478 FOR BOTH BODY AND MECHANICAL.

**Confidential**

REF. #

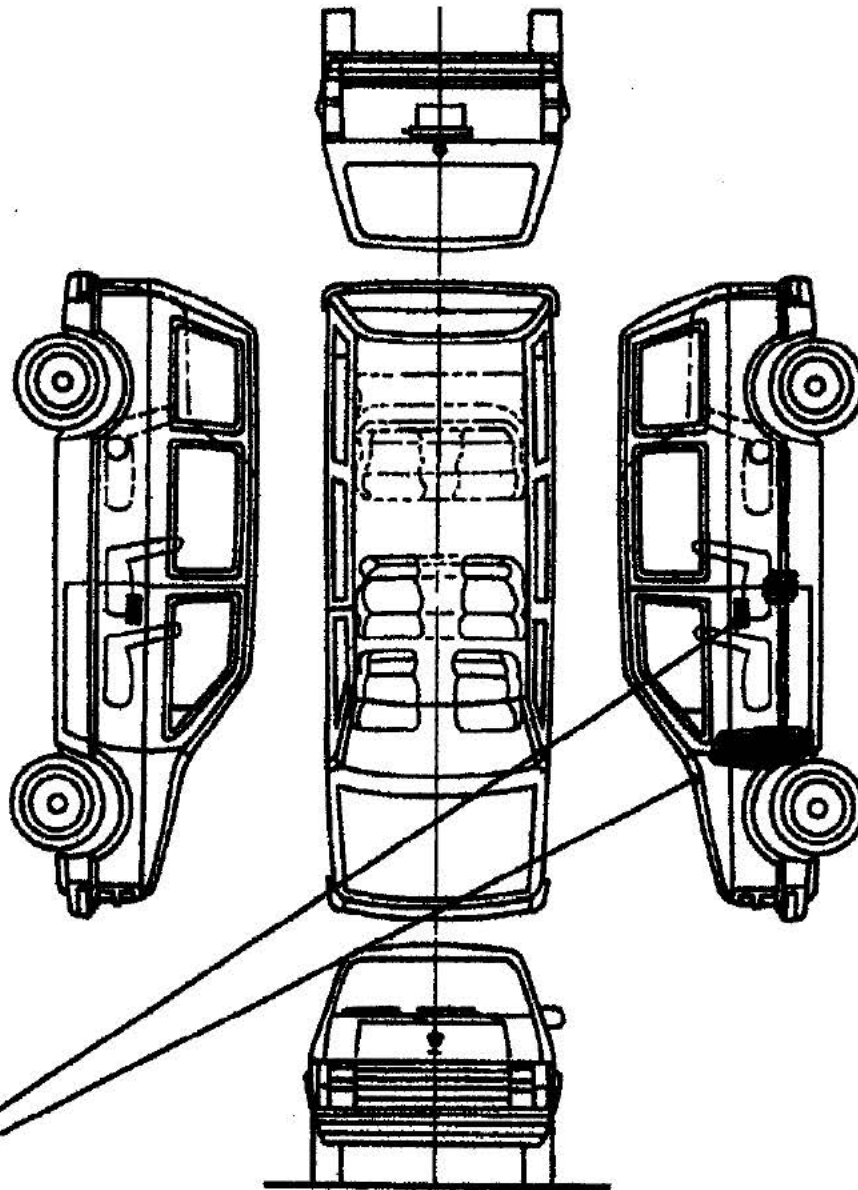
**Exterior Damage Diagram and Measurements**

LEFT FRONT FENDER AND DRIVERS DOOR PANEL DENTED AS WELL AS AREA NEAR DRIVERS DOOR AND CAB. DOOR HINGES ARE SPRUNG AND DOOR INNER PANEL WARPED. MOLDING ALONG THE ENTIRE SIDE OF THE UNIT WAS SCRATCHED.

**Sketch damage on all views. Include dimensions to describe and locate each damaged area and maximum depth of penetration for each impact. Annotate observations which might be useful in reconstructing the accident (e.g., direction of scrapes, markings on tires and wheels, etc.). Take photographs.**

Date: 8/2/99 08:46 AM  
Estimate ID:  
Estimate Version:  
Committed  
Profile ID:

STATE FARM INSURANCE COMPANIES

2435 W. Congress St. LaFayette, LA 70506  
(318) 261-3400  
Fax: (318) 261-3451

FOR ANY QUESTIONS REGARDING THIS ESTIMATE,  
PLEASE CONTACT THE INDICATED CLAIMS HANDLER

\*\*\*\*\*  
\* BODY SHOP: TO REQUEST A SUPPLEMENT TO THIS ESTIMATE, \*  
\* PLEASE FAX YOUR REQUEST TO (318) 261-3431 \*  
\*\*\*\*\*

Damage Assessed By: Billy Comeaux

Claims Rep: Team 3 Processor  
(800) 448-4587

Type of Loss:  
Date of Loss:  
Deductible:  
Claim Number:

CAIR

Insured:  
Address: GLENMORA, LA  
Telephone: Work Phone: ( )

Home Phone:

Mitchell Service: 914527

Description:  
Body Style:  
VIN:  
OEM/ALT: A  
Color: BLK

Drive Train: 5.9L Turbo Inj 6 Cyl Dsl 2WD  
License:  
Search Code: SFLFT

Line Item	Entry Number	Labor Type	Operation	Line Item Description	Part Type/ Part Number	Dollar Amount	Labor Units
1	407310	BDY	REPAIR	L FENDER PANEL	Existing		4.0* #
2	AUTO	REF	REFINISH	L FENDER OUTSIDE			C 1.7
3				BLEND COLOR W/IN PANEL			
4	400622	BDY	REMOVE/INSTALL	L FENDER SKIRT	Existing		0.4* #
5				TO AID FENDER REPAIR			
6	407510	BDY	REMOVE/REPLACE	L FENDER RIVET	34201631	1.25	
7	402064	BDY	REPAIR	L CAB SIDE PANEL	Existing		2.0* #
8				LFT HINGE PILLAR AREA			
9		REF	REFINISH/REPAIR	L CAB SIDE PANEL			1.0*
10	402515	BDY	REPAIR	L CAB CORNER PANEL	-S Existing		2.0* #
11	AUTO	REF	REFINISH	L CAB CORNER PANEL			C 1.4
12	402093	BDY	REMOVE/REPLACE	L CAB MOULDING	55076543	19.75	
13	401553	BDY	REMOVE/REPLACE	L FRT DOOR SHELL	55023573AD	545.00	3.0 #
14	AUTO	REF	REFINISH	L FRT DOOR OUTSIDE			C 2.0

ESTIMATE RECALL NUMBER: 8/ 2/99 08:46:26 18-0256-88301

Mitchell Data Version:

JUL\_99\_B

UltraMate is a Trademark of Mitchell International  
Copyright (C) 1994 - 1999 Mitchell International  
All Rights Reserved



PE14-013

CHRYSLER

8-11-2014

ENCLOSURE 6

Field Reports PUBLIC

CUSTOMER COMPLAINTS

PEER VEHICLE REPORTS

MADE BY DAIMLERCHRYSLER CORPORATION

DATE OF MFG 4-82

GAWR 4763 KG (10500 LB)

GAWR FRONT 2042 KG (4500 LB)

WITH TIRES LT235/85R16-E

RIMS AT 16X6

COLD 379 KPA (55 PSI)

GAWR REAR 3402 KG (7500 LB)

WITH TIRES [REDACTED]

RIMS AT 16X6

COLD 344 KPA (50 PSI)

[REDACTED]

FEDERAL MOTOR VEHICLE SAFETY AND THEFT  
OF MANUFACTURE SHOWN ABOVE.

CY SINGLE DUAL X

IN MEXICO 101-3442 4048507







TODAY WE REMOVE ONLY PAPER AND GLASS







TOW-IN  
VEHICLES  
PARKING ONLY























PAINT

THAN 12 2000

PERFORM

PAINT THIS 24







WANT THE SIDE UP  
MMA PERFORMANCE  
ESTE LADO HACIA ARRIBA

WANT THE SIDE UP  
MMA PERFORMANCE  
ESTE LADO HACIA ARRIBA















ESTE LADO HACIA ARRIBA

PERFORMAN

POINT THIS SIDE

ESTE LADO







ARGO  
HOME  
OFF



100 13









1. 1990 - 2007 Systems  
2. 1989 - 1997 Diagnostics  
3. Vehicle Module Scan  
4. Customer Preference  
5. Junction Port Tool  
6. TechCONNECT Database order

Page 1 of 1

HELP

F1 F2 F3 F4

Clipboard with a document containing text, including a name and address, and a yellow sticky note.



1. Engine  
2. Transmission & Clutch  
3. Body Interior  
4. Chassis & Body Exterior  
5. Anti-lock Brakes  
6. Passive Restraints  
7. Theft Alarm  
8. System Monitor

Page 1 of 1

HELP

SVS

49.1

F1

F2

F3

F4

ENTER

Clipboard with a document containing text, including a name field and a list of items.

Name: \_\_\_\_\_  
Address: \_\_\_\_\_  
City: \_\_\_\_\_  
State: \_\_\_\_\_  
Zip: \_\_\_\_\_

1. Radio  
2. Cassette  
3. CD Player  
4. Power Windows  
5. Power Locks  
6. Power Mirrors  
7. Power Seats  
8. Power Steering  
9. Power Sunroof  
10. Power Windows

Engine Control Module  
2007 GMZelle 5.9L Turbo Diesel, Diesel Fuel  
Federal/Canadian Module  
Man. Trans, AV Drive, Heavy Duty  
Cummins Engine, Cummins  
No Electric Fan  
FCM Part# 9108363893  
Homologation TD  
EPA OBD Vehicle

F1 F2 F3 F4

1. System Tests  
2. **ECU's & Related Components**  
3. Module Display  
4. Sensor Display  
5. Input/Output Display  
6. Monitor Display  
7. Custom Display  
8. Actuator Tests  
9. OBD II Monitors

Page 1 of 2

HELP

SYS

MAIN

F1 F2 F3 F4

ENTER

Clipboard with a document containing text, possibly a repair order or diagnostic report, partially visible in the background.



















YEAR 02  
MAKE Dodge  
MODEL Ram 3500  
BODY W  
COLOR W

1 Home's  
 NEW  
 USED



PE14-013

CHRYSLER

8-11-2014

ENCLOSURE 6

Field Reports PUBLIC

CUSTOMER COMPLAINTS

PEER VEHICLE REPORTS

MFD BY DAIMLERCHRYSLER CORPORATION DATE OF MFR 10-06 GVWR 4083 KG(9000 LB)

GVWR FRONT	WITH TIRES	RIMS AT	COLD
2359 KG(5200 LB)	LT265/70R17E	17X8.0	410 KPA( 60 PSI)
GVWR REAR	WITH TIRES	RIMS AT	COLD
2727 KG(6010 LB)	LT265/70R17E	17X8.0	485 KPA( 70 PSI)

THIS VEHICLE CONFORMS TO ALL APPLICABLE FEDERAL MOTOR VEHICLE SAFETY AND THEFT PREVENTION STANDARDS IN EFFECT ON THE DATE OF MANUFACTURE SHOWN ABOVE.

VIN: 3D7KS28CX7G [REDACTED] TYPE: TRUCK SINGLE X [REDACTED]



MDH: 101809 PNT:PB7 VEHICLE MADE IN MEXICO TRM:M9J3 4648507



28970













RAM  
HEAVY DUTY

RAM



























ALL INFORMATION CONTAINED HEREIN IS UNCLASSIFIED  
DATE 08/11/2010 BY 60322 UCBAW/STP

  
MOPAC  
**MaxPro SAE 5W-30**  
SAE 5W-30  
SAE 5W-30  
SAE 5W-30



Heavy Duty Road

Snap-on

MOPAR  
MaxPro SAE 5W-30  
MAXPRO SAE 5W-30





Controller Name	Active	DTCs	Bus
PCM Powertrain Control Module	<input checked="" type="checkbox"/>	0	CAN C
ABS Anti Lock Brakes	<input checked="" type="checkbox"/>	0	CAN C
CCN Instrument Cluster/Cabin Compartment	<input checked="" type="checkbox"/>	0	CAN B
EOM Electronic Overhead	<input checked="" type="checkbox"/>	0	CAN B
HVAC Heat, Ventilation and A/C	<input checked="" type="checkbox"/>	0	CAN B
ORC Occupant Restraint	<input checked="" type="checkbox"/>	0	CAN B
RADIO Radio	<input checked="" type="checkbox"/>	0	CAN B
TIPMCGW Central Gateway	<input checked="" type="checkbox"/>	0	DIAG CAN C

Back

Controller Name	Active	DTCs	Bus
CCM Instrument Cluster/Cabin Compartment	<input checked="" type="checkbox"/>	0	CAN B
EOM Electronic Overhead	<input checked="" type="checkbox"/>	0	CAN B
HVAC Heat, Ventilation and A/C	<input checked="" type="checkbox"/>	0	CAN B
ORC Occupant Restraint	<input checked="" type="checkbox"/>	0	CAN B
RADIO Radio	<input checked="" type="checkbox"/>	0	CAN B
TIPMCGW Central Gateway	<input checked="" type="checkbox"/>	0	DIAG CAN C
WCM Wireless Control	<input checked="" type="checkbox"/>	0	CAN B

Check PCM VIN

This VIN is valid. Press "Finish" to exit.

VIN: 3D7KS28CX7G [REDACTED]

< Back

Next >

Finish

Cancel

2007 DR

### ECU Details

9.04

Show Shortcuts

ack

5.9L 3D7KS28CX7G [REDACTED]



Name	Value
Model Year	07
ECU Part Number	45325751AG
Body Style	4-Door Pickup
Vehicle Line	DR
Country Code	USA
VIN (Original)	[REDACTED]
VIN (Current)	3D7KS28CX7G [REDACTED]
Software Version (Major/Middle/M	45 01 07
Hardware Version (Major/Minor)	00 03
Serial Number	7636
Supplier ID	Cummins
Variant ID	05
Diagnostic Version	04
VMM Version	0443
Software (Boot) Part Number	00000000AA
Software Version (Major/Middle/M	01 03 52

Config Info

Toggle Row Height

Back

2007 DR

5.9L 3D7KS28CX7G [REDACTED]

### ECU Details

9.04

Show Shortcuts



Name	Value
Country Code	USA
VIN (Original)	[REDACTED]
VIN (Current)	3D7KS28CX7G [REDACTED]
Software Version (Major/Middle/M	45 01 07
Hardware Version (Major/Minor)	00 03
Serial Number	7636
Supplier ID	Cummins
Variant ID	05
Diagnostic Version	04
VMM Version	0443
Software (Boot) Part Number	00000000AA
Software Version (Major/Middle/M	01 03 52
ECU File Name	PCM/PCM/05
ECU ID	16
ECU Database ID	1764

Config Info

Toggle Row Height







PE14-013

CHRYSLER

8-11-2014

ENCLOSURE 6

Field Reports PUBLIC

CUSTOMER COMPLAINTS

PEER VEHICLE REPORTS











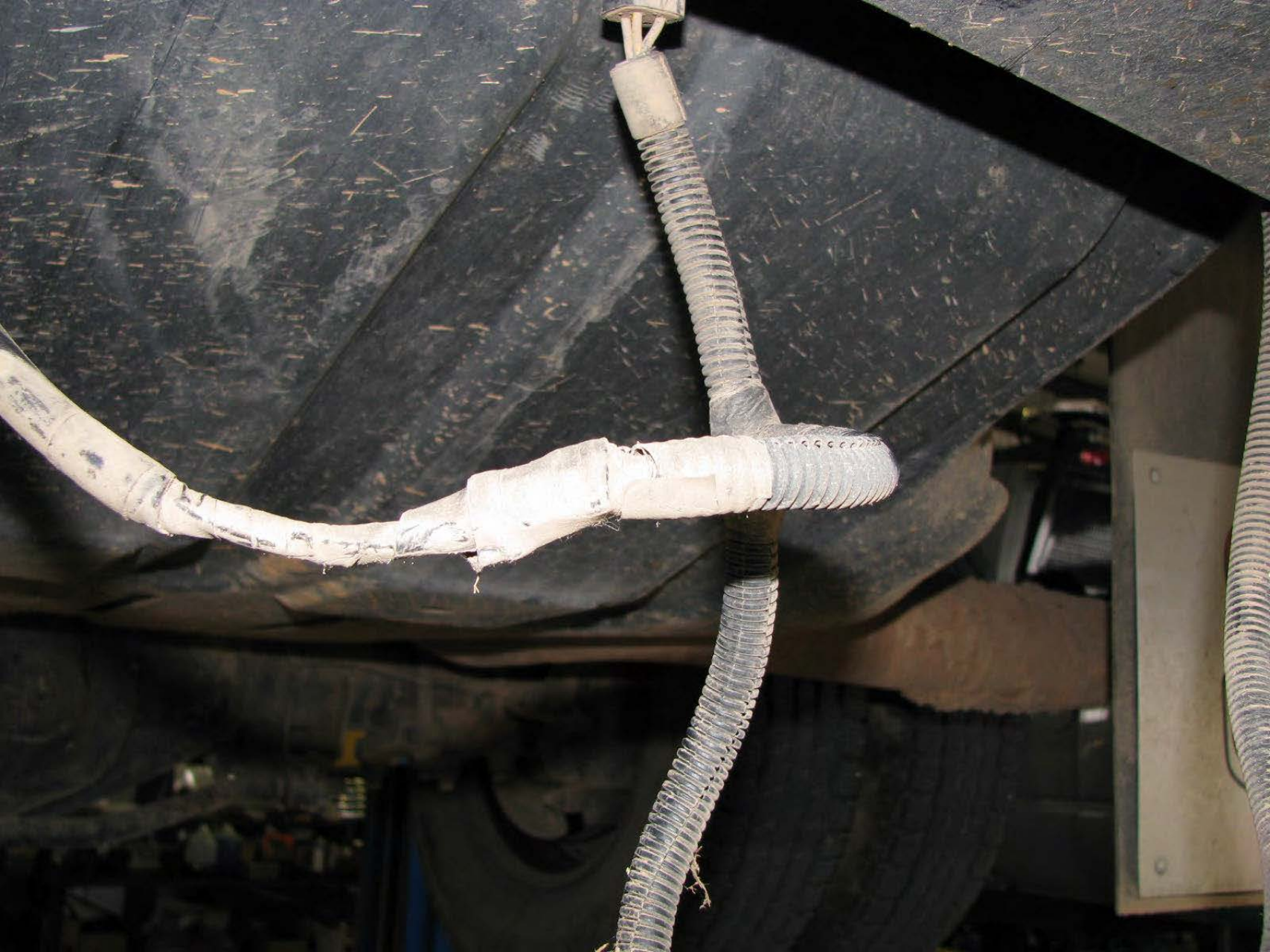

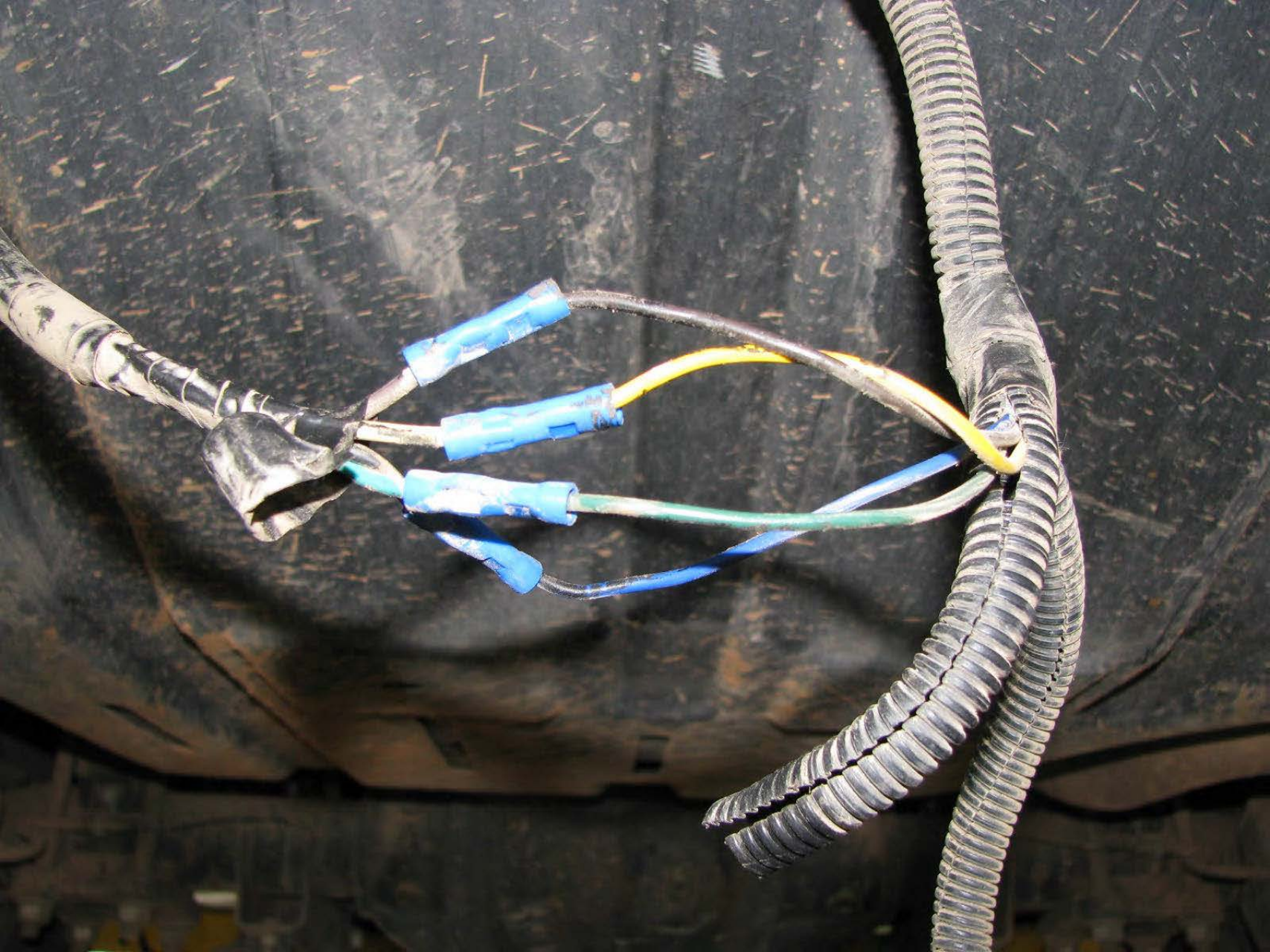

















RPM x 1000

4  
5

30 60 90 120 150 180 200  
20 40 60 80 100 110  
10 20 30  
0  
MPH km/h

19630

0 40 110

140 200 245







GOT MILK?



GOT MLK?



RAM  
3500  
LIBERTY (4x4)







CM  
Truck Beds

SPRINGDALE  
DODGE

cmtruckbeds.com

SPRINGDALE  
DODGE  
SPRINGDALE, AR

SPRINGDALE  
DODGE  
SPRINGDALE, AR



MOPAR®



MOPAR



GENUINE  
MOPAR

GENERAL

GENERAL  
R1C100













SAFE  
2015

MP

PELICAN

PELICAN  
SAFE



428000-3330  
DENSO

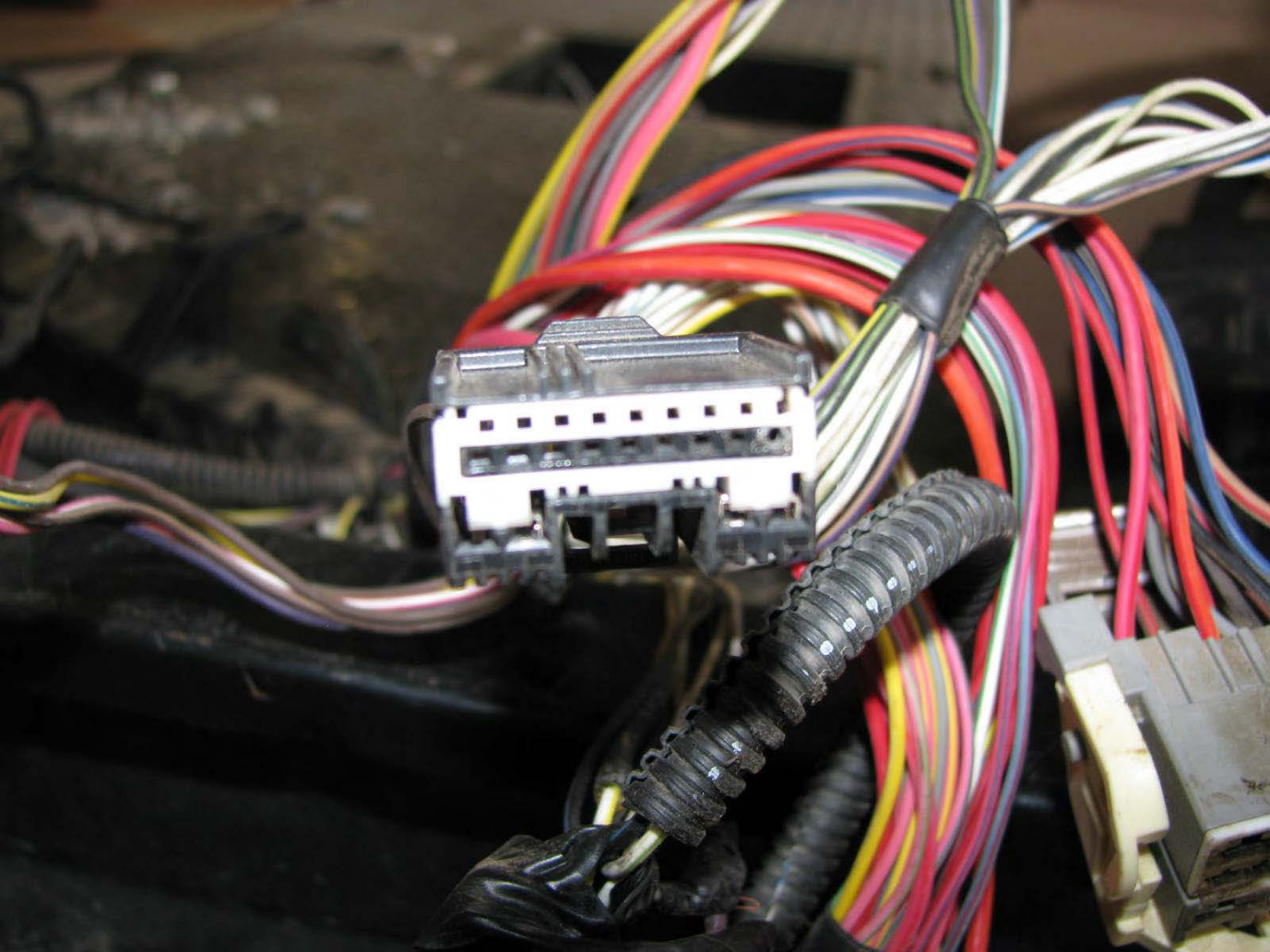

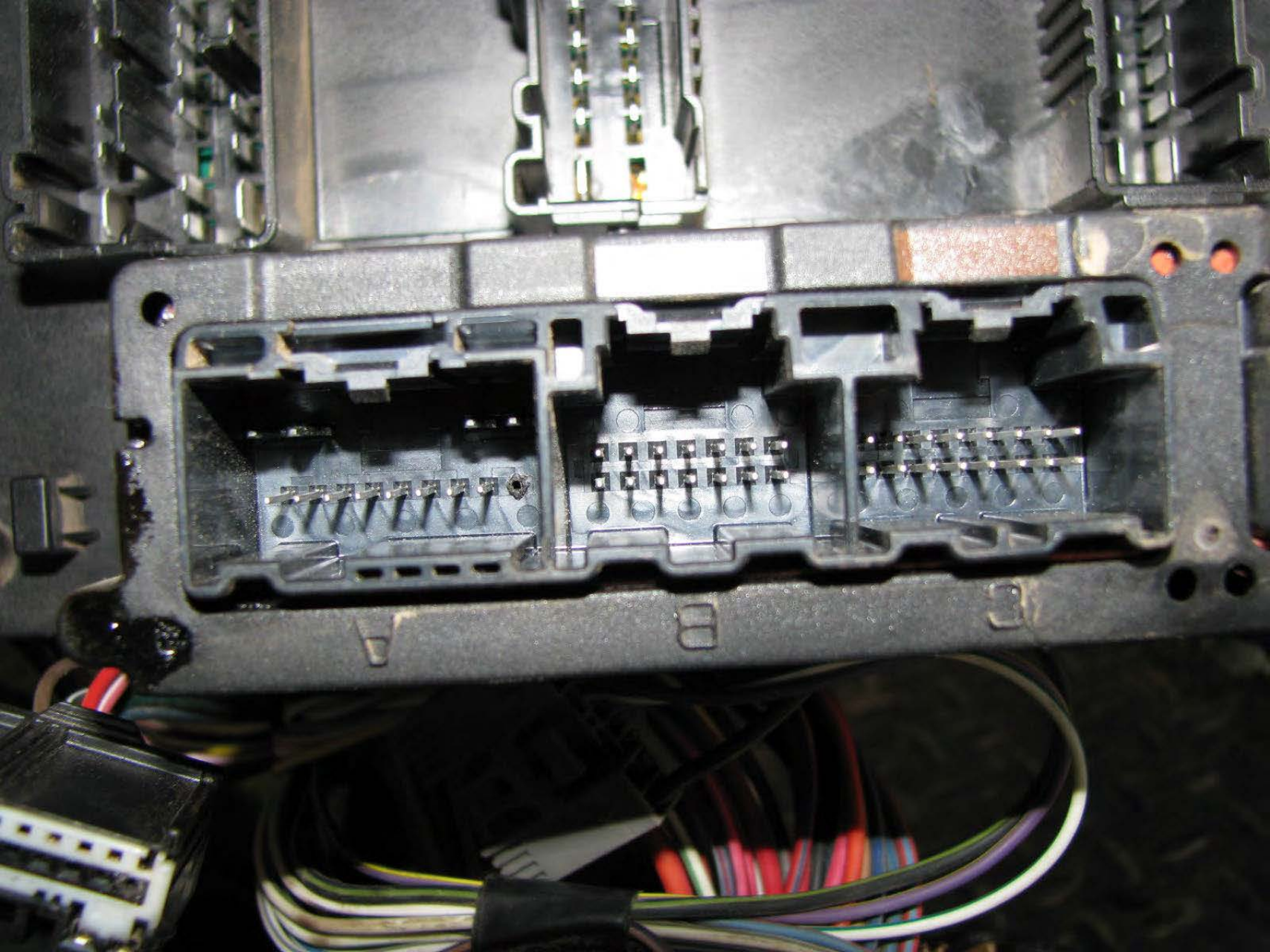

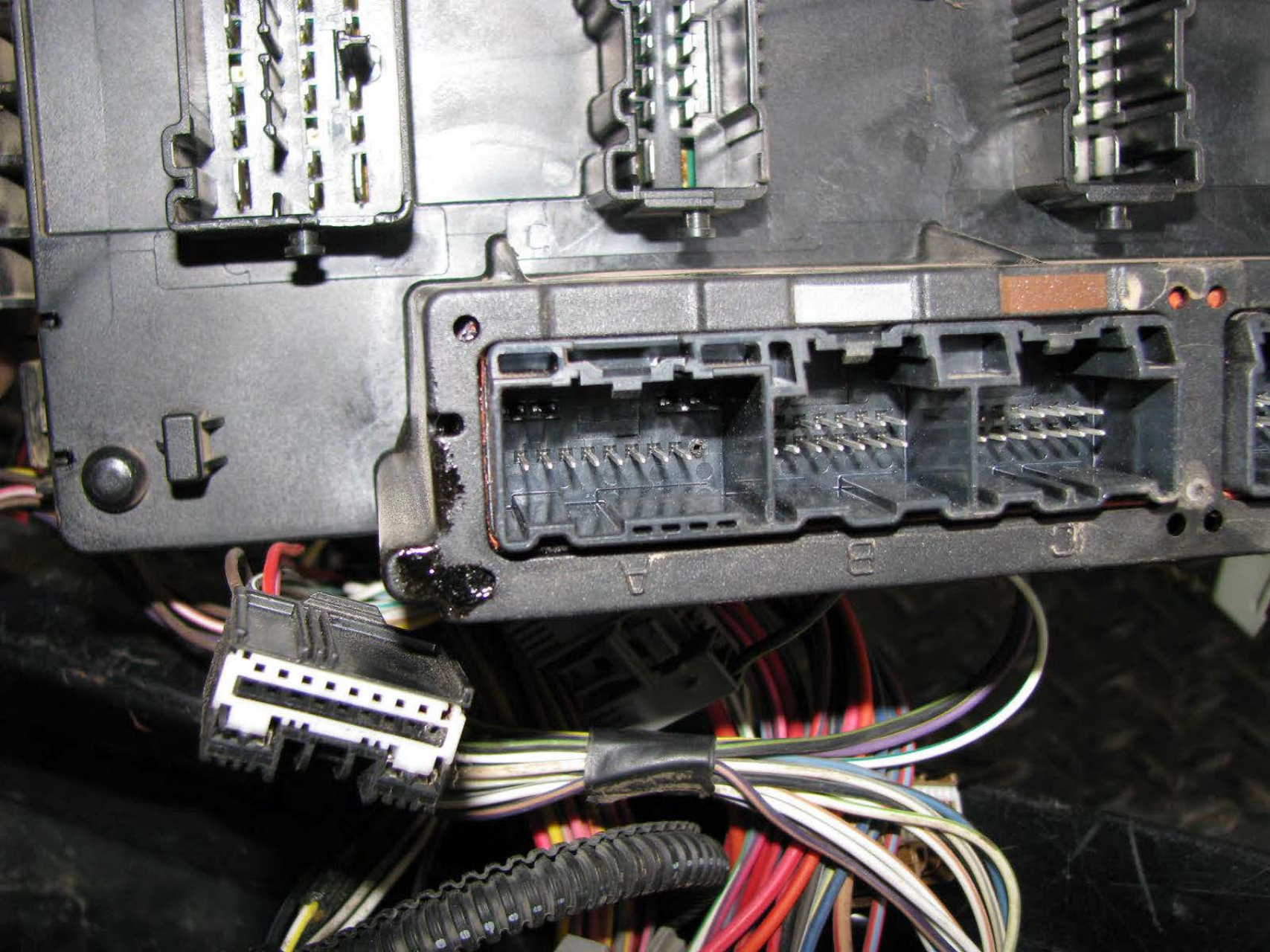

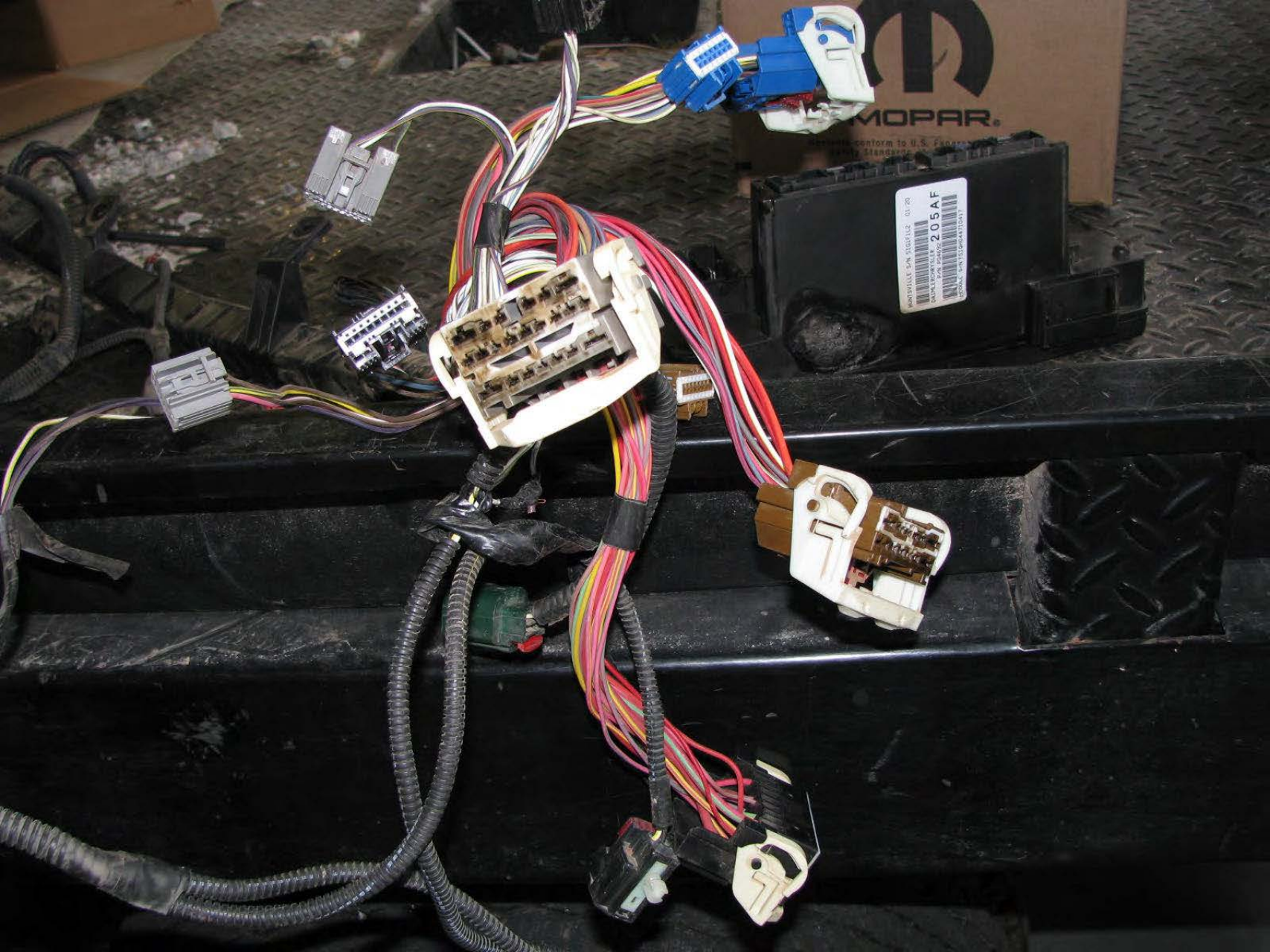

MOPAR

conform to U.S. Standards

ANDERVILLE PA 15016 LC 01 20  
MOPAR 205AF  
MOPAR 205AF  
CONTRACT PARTS CONTACT 1-800-4-A-MOPAR



REPAIRABLE AND REPAIRABLE  
DATE OF REPAIR: 205AF  
PART NUMBER: 205AF





ENGINE OIL

CAUTION  
SPECIFIC ENGINE  
OILS ARE ONLY  
USE GENERAL RANGE

WASHER FLUID

CAUTION  
[Warning symbol]  
[Additional text]





WARNING

405AA  
2003

DANGER / POISON  
AVOID CONTACT WITH EYES  
AVOID CONTACT WITH SKIN  
AVOID CONTACT WITH CLOTHING  
AVOID CONTACT WITH ELECTRICAL CONNECTIONS  
AVOID CONTACT WITH HOT SURFACES  
AVOID CONTACT WITH MOVING PARTS  
AVOID CONTACT WITH OPEN FLAMES  
AVOID CONTACT WITH SPARKING TOOLS  
AVOID CONTACT WITH ELECTRICAL WIRING  
AVOID CONTACT WITH ELECTRICAL COMPONENTS  
AVOID CONTACT WITH ELECTRICAL CONNECTIONS  
AVOID CONTACT WITH ELECTRICAL WIRING  
AVOID CONTACT WITH ELECTRICAL COMPONENTS







Manufactured by  
Contract Mfg., Inc.



ID# 16470

CM

Truck Beds





EDGE  
SPRINGDALE, AR



PE14-013

CHRYSLER

8-11-2014

ENCLOSURE 6

Field Reports PUBLIC

CUSTOMER COMPLAINTS

PEER VEHICLE REPORTS

From: [REDACTED]  
To: [REDACTED]  
Date: Thu Dec 10 22:56:38 EST 2009  
Subject: Chrysler Group LLC Customer Assistance  
Form Selected:

-----  
Category: US Customer Service  
Brief Description:  
-----

I still have that same problem in addition to another one

Comments:  
-----

I had to take my truck back into the dealership Wednesday afternoon for the same thing yet again and they didn't want to give me a loner until I told them the truck was under extended warranty and this was a preexisting condition. They called me on Thursday afternoon and said they couldn't duplicate the problem and that I needed to come get it and return the rental, as they couldn't rent it for another day. The problem still exists. In addition, they were to repair my clutch safety switch. They fixed the switch but now when I change gears it sometimes makes a very audible noise and I am afraid the clutch is not going to work when I need it. I have never seen a company that has so many people that don't know their job.. They can't or won't fix my truck. I truly hate to take my vehicles there. They fix one thing only to mess something else up.. I am beginning to think the lemon law would apply in this case.. Please, Can I have someone call me so we can discuss this matter..

Sender Information:  
-----

Title: Ms.  
First Name: [REDACTED]  
Middle Initial: [REDACTED]  
Last Name: [REDACTED]

PE14-013

CHRYSLER

8-11-2014

ENCLOSURE 6

Field Reports PUBLIC

CUSTOMER COMPLAINTS

PEER VEHICLE REPORTS

MFG BY CHRYSLER LLC

WHL R# 0-45

WGT 3534 KG 7790 LB

WHL FRNT 2100 KG 4625 LB WTR LT225/65R17C 1003

WHL RR 450 KG 990 LB WTR LT225/65R17C 1003

WHL REAR 450 KG 990 LB WTR LT225/65R17C 1003

WHL RR 450 KG 990 LB WTR LT225/65R17C 1003



THIS VEHICLE CONFORMS TO ALL APPLICABLE U.S.A. FEDERAL MOTOR VEHICLE SAFETY STANDARDS IN EFFECT ON THE DATE OF MANUFACTURE SHOWN ABOVE.

VIN: 2C3P046L5G [REDACTED] WTR: TRUCK  
WHEEL BASE IN MM: 3000 WTR: 118.1 WTR: 3000

























































SEE OWNER'S MANUAL FOR FUSE DETAILS





























HOOD

























G2704 127















**▲ WARNING**

**DEATH OR SERIOUS  
INJURY CAN OCCUR**



- CHILDREN 12 AND UNDER CAN BE KILLED BY THE AIR BAG.
- THE BACK SEAT IS THE SAFEST PLACE FOR CHILDREN.
- NEVER PUT A REAR-FACING CHILD SEAT IN THE FRONT.
- SIT AS FAR BACK AS POSSIBLE FROM THE AIR BAG.
- ALWAYS USE SEAT BELTS AND CHILD RESTRAINTS.



93261001AB



PE14-013

CHRYSLER

8-11-2014

ENCLOSURE 6

Field Reports PUBLIC

CUSTOMER COMPLAINTS

PEER VEHICLE REPORTS

From: [REDACTED]  
To: [REDACTED]  
Date: Wed Sep 08 16:10:48 EDT 2010  
Subject: Chrysler Group LLC Customer Assistance  
Form Selected:

-----  
Category: US Customer Service  
Brief Description:  
-----

Ref# 19906613

Comments:  
-----

update please

also, please read following strig of communication between dealer service and myself. The last of which they did not respond to.

[REDACTED]

I have isolated the problem to the clutch switch, which is obviously broken. It must be made to start the truck but open for the cruise to work. When a switch comes apart it stays in a closed state which allows the truck to start and run but does not allow the cruise function. I first noticed a problem when I was able to start the truck without the clutch being depressed which could be dangerous. I currently have it rigged to be bypassed with a toggle switch, which allows both functions as once the truck is started the circuit can be broken and the cruise function works fine. What should be the plan moving forward?

Thanks

[REDACTED]

To: [REDACTED]  
service [REDACTED]  
Sent: Wed, Aug 25, 2010 4:13  
pm  
Subject: Re: Service Concern

[REDACTED]

Thanks, you are correct, i had gone to Chrysler's recall site and they told me this truck had 4 recalls and their records showed i was ok on all 4.

I am having another issue though, the cruise doesn't work. Guess I should have thought to check it before i bought it but i never took it on the highway during the test drive and i did not question it as the truck only has 14k mi. on it. the lights work on the wheel and dash it just doesn't engage. The used car

warranty box is checked on my paperwork, i just bought it,8/19. Any chance it is covered? What would be the best way to proceed?

thanks,

-----Original Message-----

From: Service

To:

Sent:

Wed, Aug 25, 2010 2:39 pm

Subject: Service Concern

Hi

I just wanted to email you back and let you know that we did receive your email here at the store. I also did check your vin. # through the Chrysler recall system. I am familiar with the recall that you mentioned, however your vehicle DOES NOT APPLY. If you are still having a concern with a vibration in the vehicle I will be happy to check out the truck for you.

Please let me know if I can be of any assistance and we will be happy to check things out for you. Thanks.

Tony  
Nally  
Service Manager  
Buchanan Auto Park

Sender Information:

-----  
Title: Mr.  
First Name: [REDACTED]  
Middle Initial: [REDACTED]  
Last Name: [REDACTED]

From: [REDACTED]  
To: [REDACTED]  
Date: Fri Sep 10 16:01:21 EDT 2010  
Subject: Re: Chrysler Group LLC Customer Assistance  
Dear [REDACTED]:

Thank you for contacting the Chrysler Customer Assistance Center regarding your open case - Ref#19906613.

I have updated your file with the information from your latest email.

Your Case Manager will be in contact with you as soon as possible.

Thanks again for your email.

Sincerely,

[REDACTED]  
Customer Service Representative  
Chrysler Customer Assistance Center

For any future communications related to this email, please refer to the following information:

REFERENCE NUMBER: 19916333  
EMAIL CASE NUMBER: 2501988

Original Message Follows:  
-----

US Customer Service - Dodge Brand Site

Brief Description:

Ref# 19906613

Comments:

update please also, please read following strig of communication between

dealer service and myself. The last of which they did not respond to.

Tony, I have isolated the problem to the clutch switch, which is obviously broken. It must be made to start the truck but open for the

cruise to work. When a switch comes apart it stays in a closed state which

allows the truck to start and run but does not allow the cruise function. I

first noticed a problem when I was able to start the truck without the

clutch being depressed which could be dangerous. I currently have it rigged

to be bypassed with a toggle switch, which allows both functions as once

the truck is started the circuit can be broken and the cruise function

works fine. What should be the plan moving forward? Thanks, Bob

-----Original Message----- From: [REDACTED] To:

service Sent: Wed, Aug 25, 2010 4:13 pm

Subject: Re: Service Concern Tony, Thanks, you are correct, i had gone to Chrysler's recall site and they told me this truck had 4 recalls

and their records showed i was ok on all 4. I am having another

issue

though, the cruise doesn't work. Guess I should have thought to check it

before i bought it but i never took it on the highway during the test drive

and i did not question it as the truck only has 14k mi. on it. the lights

work on the wheel and dash it just doesn't engage. The used car warranty

box is checked on my paperwork, i just bought it,8/19. Any chance it is

covered? What would be the best way to proceed? thanks, Bob

-----Original Message----- From: Service

To: [REDACTED] Sent: Wed, Aug 25, 2010 2:39 pm

Subject: Service Concern Hi Bob, I just wanted to

email you back and let you know that we did receive your email here at the

store. I also did check your vin. # through the Chrysler recall system. I

am familiar with the recall that you mentioned, however your vehicle DOES

NOT APPLY. If you are still having a concern with a vibration in the vehicle I will be happy to check out the truck for you. Please let

me

know if I can be of any assistance and we will be happy to check things out

for you. Thanks [REDACTED] Service Manager Buchanan Auto Park

7

VIN:

60 [REDACTED]

Mileage:

14750

Servicing Dealer:

Title:

Mr.

First Name:

Middle

Last Name:

Address:

Address 2:

City:

New Cumberland

State:

PA

Zip:

Email:

Home P [REDACTED]

PE14-013

CHRYSLER

8-11-2014

ENCLOSURE 6

Field Reports PUBLIC

CUSTOMER COMPLAINTS

PEER VEHICLE REPORTS

RECEIVED DATE:

11/29/10

POSTED DATE:

\_\_\_\_\_

LAST NAME:

\_\_\_\_\_ [REDACTED] \_\_\_\_\_

VIN (LAST 8 DIGITS)

\_\_\_\_\_ 6J [REDACTED] \_\_\_\_\_

CAIR

\_\_\_\_\_ [REDACTED] \_\_\_\_\_

NON- SCANABLE ITEMS: CIRCLE ONE

NO

YES

Nov 18,, 2010

To Whom it may Concern

Re [REDACTED]

As per your request, enclosed please find the receipts for work done on my truck.

I submit them for reimbursement

Please send the approved reimbursement to

[REDACTED]  
Oceanside, CA [REDACTED]

Sincerely,  
[REDACTED]

CUSTOMER #: [REDACTED]

# Bob Baker

CHRYSLER-JEEP-DODGE

Car Country Carlsbad

\*INVOICE\*

5515 & 5555 CAR COUNTRY DRIVE  
CARLSBAD, CALIFORNIA 92008  
(760) 431-3000

CARLSBAD, CA [REDACTED]

PAGE 1

BAR # ARD170193 EPA # CAL0000197053-5555  
EPA # CAL287232-5515

HOME [REDACTED] CONT:N/A

BUS: [REDACTED] CELL:

SERVICE ADVISOR: [REDACTED]

COLOR	YEAR	MAKE/MODEL	VIN	LICENSE	MILEAGE IN / OUT	TAG	
	06	DODGE RAM15	1D7HA18K56J [REDACTED]		49280/49282	[REDACTED]	
DEL DATE	PROD DATE	WARR EXP.	PROMISED	PO NO.	RATE	PAYMENT	INV
01JAN06 DD			17:00 22OCT10			CASH	22OCT10

R/O OPENED READY OPTIONS: ENG:3.7 LITER MPI

08:11 20OCT10	14:37 22OCT10						
LINE	OPCODE	TECH	TYPE	HOURS	LIST	NET	TOTAL

A CUSTOMER STATES THAT WHEN USING THE RIGHT TURN THE LEFT WILL FLASH,  
CRUISE CONTROL INTERMITTANT OPERATION, BACK UP LIGHTS ARE INOP  
CAUSE: OPEN CIRCUIT

08808702 Switch, multifunction - Test and replace  
Left stalk (B)  
658 WC40

- 1 [REDACTED] MODULE-TOTALLY INTEGRATED
- 1 [REDACTED] SWITCH-MULTIFUNCTION

(N/C)  
(N/C)  
(N/C)

FC:  
PART#: 56049888AR  
COUNT: 1  
CLAIM TYPE: F  
AUTH CODE:

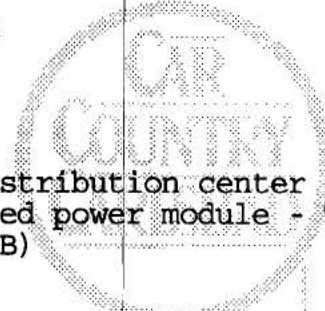

08890102 PDC Power distribution center / TIPM  
totally integrated power module - Test and  
replace Module (B)  
658 WC40

FC: PART#: COUNT:  
CLAIM TYPE: F  
AUTH CODE:

(N/C)

08890150 Power distribution center PDC / totally  
integrated power m  
658 WC40

FC: PART#: COUNT:  
CLAIM TYPE: F  
AUTH CODE:

(N/C)

PARTS: 0.00 LABOR: 0.00 OTHER: 0.00 TOTAL LINE A: 0.00

49280 OPEN CIRCUIT 08808702 (L3) D5 .2 08890102 UC .5 08890150 .3 1.00

CUSTOMER SATISFACTION IS OUR TOP PRIORITY!

We Feature:

- Rental Cars
- Latest in Diagnostic Equipment
- Expert Factory Trained Technicians

**MEMBERS OF BOB BAKER  
AUTOMOTIVE GROUP**

"Where it's so Nice to be Nice"

THANK YOU FOR THIS OPPORTUNITY TO SERVE YOU. WE  
TRUST YOU WERE SERVED IN A COURTEOUS AND  
PROFESSIONAL MANNER. IF YOU HAVE ANY QUESTIONS,  
PLEASE NOTIFY YOUR SERVICE ADVISOR IMMEDIATELY.

ORIGINAL ESTIMATE	REVISED ESTIMATE	DESCRIPTION	TOTALS
\$	\$	LABOR AMOUNT	
		PARTS AMOUNT	
I acknowledge notice and oral approval of an increase in the original estimated price.		GAS, OIL, LUBE	
X _____ CUSTOMER SIGNATURE		SUBLET AMOUNT	
SUBJECT TO THE CONDITIONS ON THE REVERSE SIDE OF THIS CONTRACT. CUSTOMER ACKNOWLEDGES RECEIPT OF A COPY HEREOF.		MISC. CHARGES	
NOTICE TO CUSTOMER: PLEASE READ IMPORTANT INFORMATION ON BACK.		TOTAL CHARGES	
CUSTOMER SIGNATURE		DISCOUNT	
X _____		SALES TAX	
		PLEASE PAY THIS AMOUNT	

WARNING Motor vehicles contain chemicals known to the State of California to cause cancer and birth defects or other reproductive harm. These chemicals are contained in many vehicle components and replacement parts, vehicle fluids, and paints and materials used to maintain vehicles, including, but not limited to, fuel, oil, batteries, brakes, and wheel balancing weights. When you service, clean or maintain your car, you will be exposed to listed chemicals contained in used oil, waste and replacement fluids, tuners, grease, grime, touch-up paint, certain replacement parts, and particulates from component wear. When we service your car, we will return used components to you upon request. Used parts and components contain chemicals known to the State of California to cause cancer and birth defects or other reproductive harm. To minimize your exposure when servicing, maintaining or cleaning your vehicle: 1) work in a well ventilated area; 2) do not eat, drink, or smoke; 3) wash your hands when finished or when taking a break; and 4) follow all manufacturer instructions pertaining to proper use and maintenance of motor vehicles and vehicle components. Posted in accordance with Proposition 65 in Cal. Health & Safety Code 25249.3(a) For further information about Proposition 65: <http://www.oehha.org/prop65.html>.

# Bob Baker

CHRYSLER-JEEP-DODGE

Car Country Carlsbad

5515 & 5555 CAR COUNTRY DRIVE  
CARLSBAD, CALIFORNIA 92008  
(760) 431-3000

CUSTOMER #: [REDACTED]

\*INVOICE\*

PAGE 2

BAR # ARD170193 EPA # CAL0000197053-5555  
EPA # CAL287232-5515

CARLSBAD, CA [REDACTED]  
HOME: [REDACTED] CONT: N/A  
BUS: [REDACTED] CELL: [REDACTED]

SERVICE ADVISOR: 6 [REDACTED]

COLOR	YEAR	MAKE/MODEL	VIN	LICENSE	MILEAGE IN / OUT	TAG	
	06	DODGE RAM15	1D7HA18K56J [REDACTED]		49280/49282	[REDACTED]	
DEL DATE	PROD. DATE	WARR. EXP.	PROMISED	PO NO.	RATE	PAYMENT	INV. DATE
01JAN06 DD			17:00 22OCT10			CASH	22OCT10
R.O. OPENED	READY	OPTIONS: ENG: 3.7 LITER MPI					
08:11 20OCT10	14:37 22OCT10						

LINE	OPCODE	TECH	TYPE	HOURS	LIST	NET	TOTAL
TURN SIGNALS WILL FLASH RIGHT AT TIMES WHEN LEFT TURN SIGNAL APPLIED-INTERNAL SWITCH FAILURE REMOVED AND INSTALLED NEW MULTIFUNCTION SWITCH--BACK UP LIGHTS IONP--INSPECTED CURRENT FLOW A BULB CONNECTOR -NO CURRENT -INSPECTED CONNECTOR C7 PIN 8 AT TIPM WHITE WIRE WITH GREEN TRACER NO OUT PUT FROM TIPM-REMOVED AND INSTALLED NEW TIPM AND RECONFIGURED.							

\*\*\*\*\*  
B PERFORM MANDATORY (ARB) TIRE INFLATION SERVICE, CHECK AND ADJUST TIRE PRESSURES TO RECOMMENDED PSI, DOCUMENT PSI SETTINGS WHEN COMPLETED.

CAUSE: MAINT  
TP PERFORM MANDATORY (ARB) TIRE INFLATION SERVICE, CHECK AND ADJUST TIRE PRESSURES TO RECOMMENDED PSI, DOCUMENT PSI SETTINGS WHEN COMPLETED.

PARTS: 658 IPOL 0.00 LABOR: 0.00 OTHER: 0.00 TOTAL LINE B: 0.00 (N/C)

49282 MAINT 0.00 TIRE PRESSER AT 35 PSI

\*\*\*\*\*  
C\*\* LUBE, OIL, OIL FILTER WITH CONVENTIONAL MOTOR OIL, WITH MULTI POINT INSPECTION, (a separate charge of \$1.66 for the storage and disposal of the hazardous waste generated by this service)

CAUSE: MAINT  
234 LUBE, OIL, OIL FILTER WITH CONVENTIONAL MOTOR OIL, WITH MULTI POINT INSPECTION, (a separate charge of \$1.66 for the storage and disposal of the hazardous waste generated by this service)

658 CJM		1.60	1.60
1 4781452BB FILTER-ENGINE OIL	7.30	4.45	4.45
6 68055890AA 5W20 MOTOR OIL	3.42	2.15	12.90
2 L0003057 BULB	3.60	3.60	7.20

CHW HAZARDOUS WASTE FEE

CUSTOMER SATISFACTION IS OUR TOP PRIORITY!		ORIGIAL ESTIMATE	REVISED ESTIMATE	DESCRIPTION	TOTALS
We Feature:		\$	\$	LABOR AMOUNT	
<ul style="list-style-type: none"> <li>Rental Cars</li> <li>Latest in Diagnostic Equipment</li> <li>Expert Factory Trained Technicians</li> </ul>				PARTS AMOUNT	
MEMBERS OF BOB BAKER AUTOMOTIVE GROUP				GAS, OIL, LUBE	
"Where it's so Nice to be Nice"				SUBLET AMOUNT	
THANK YOU FOR THIS OPPORTUNITY TO SERVE YOU. WE TRUST YOU WERE SERVED IN A COURTEOUS AND PROFESSIONAL MANNER. IF YOU HAVE ANY QUESTIONS, PLEASE NOTIFY YOUR SERVICE ADVISOR IMMEDIATELY.				MISC. CHARGES	
I acknowledge notice and oral approval of an increase in the original estimated price.				TOTAL CHARGES	
X _____ CUSTOMER SIGNATURE				DISCOUNT	
SUBJECT TO THE CONDITIONS ON THE REVERSE SIDE OF THIS CONTRACT. CUSTOMER ACKNOWLEDGES RECEIPT OF A COPY HEREOF. NOTICE TO CUSTOMER: PLEASE READ IMPORTANT INFORMATION ON BACK.				SALES TAX	
CUSTOMER SIGNATURE				PLEASE PAY THIS AMOUNT	
X _____					

WARNING Motor vehicles contain chemicals known to the State of California to cause cancer and birth defects or other reproductive harm. These chemicals are contained in many vehicle components and replacement parts, vehicle fluids, and paints and materials used to maintain vehicles, including, but not limited to, fuel, oil, batteries, brakes, and wheel balancing weights. When you service, clean or maintain your car, you will be exposed to listed chemicals contained in used oil, waste and replacement fluids, fumes, grease, grime, touch-up paint, certain replacement parts, and particulates from component wear. When we service your car, we will return used components to you upon request. Used parts and components contain chemicals known to the State of California to cause cancer and birth defects or other reproductive harm. To minimize your exposure when servicing, maintaining or cleaning your vehicle: 1) work in a well ventilated area; 2) do not eat, drink, or use hand tools for hands when finished or when taking a break; and 4) follow all manufacturer instructions pertaining to proper use and maintenance of motor vehicles and vehicle components. Posted in accordance with Proposition 65 in Cal. Health & Safety Code 25249.5 (2001). For further information about Proposition 65: <http://www.oehha.org/prop65.html>. Copyright 2004 ADP, Inc.

CUSTOMER #

**Bob Baker**

CHRYSLER-JEEP-DODGE

Car Country Carlsbad

\*INVOICE\*

5515 & 5555 CAR COUNTRY DRIVE  
CARLSBAD, CALIFORNIA 92008  
(760) 431-3000

CARLSBAD, CA

PAGE 3

HOME: CONT:N/A

BUS: CELL:

SERVICE ADVISOR

COLOR	YEAR	MAKE/MODEL	VIN	LICENSE	MILEAGE IN / OUT	TAG	
	06	DODGE RAM15	1D7HA18K56J		49280/49282		
DEL DATE	PROD DATE	WARR EXP.	PROMISED	PO NO.	RATE	PAYMENT	INV DATE
01JAN06 DD			17:00 22OCT10			CASH	22OCT10
R.O. OPENED	READY	OPTIONS: ENG:3.7 LITER MPI					
08:11 20OCT10	14:37 22OCT10						

LINE	OPCODE	TECH	TYPE	HOURS	LIST	NET	TOTAL
PARTS:		99	CHW			1.66	1.66
		24.55	LABOR:	3.26	OTHER:	0.00	27.81
TOTAL LINE C:							

49280 MAINT SERVICE 0.40 CHANGED OIL AND OIL FILTER

\*\*\*\*\*

D\*\* \$100.00 D/D CUST TO PAY

CAUSE: D/D

100D \$100.00 D/D CUST TO PAY

99 CJ

PARTS: 0.00 LABOR: 0.00 OTHER: 0.00 TOTAL LINE D: 0.00

\*\*\*\*\*

E\*\* ALTERNATE TRANSPORTATION, (ONE DAY)

CAUSE: RENTAL

99R ALTERNATE TRANSPORTATION, (ONE DAY)

99 WC40

FC: PART#: COUNT:

CLAIM TYPE: F

AUTH CODE:

(N/C)

SUBL ENTERPRISE INV-D088839

PO#121958

WC40

FC:

PARTS: 0.00 LABOR: 0.00 OTHER: 0.00 TOTAL LINE E: 0.00

\*\*\*\*\*

F\*\* CUSTOMER STATES THAT THE CRUISE CONTROL IS INOP

CAUSE: CRUISE WILL NOT SET

14200301 Servo motor, speed control - Test and

replace

658 WC40

(N/C)

CUSTOMER SATISFACTION IS OUR TOP PRIORITY!

We Feature:

- Rental Cars
- Latest in Diagnostic Equipment
- Expert Factory Trained Technicians

**MEMBERS OF BOB BAKER  
AUTOMOTIVE GROUP**

"Where it's so Nice to be Nice"

THANK YOU FOR THIS OPPORTUNITY TO SERVE YOU. WE TRUST YOU WERE SERVED IN A COURTEOUS AND PROFESSIONAL MANNER. IF YOU HAVE ANY QUESTIONS, PLEASE NOTIFY YOUR SERVICE ADVISOR IMMEDIATELY.

ORIGINAL ESTIMATE	REVISED ESTIMATE	DESCRIPTION	TOTALS
\$	\$	LABOR AMOUNT	
		PARTS AMOUNT	
I acknowledge notice and oral approval of an increase in the original estimated price.		GAS, OIL, LUBE	
x _____ CUSTOMER SIGNATURE		SUBLET AMOUNT	
SUBJECT TO THE CONDITIONS ON THE REVERSE SIDE OF THIS CONTRACT. CUSTOMER ACKNOWLEDGES RECEIPT OF A COPY HEREOF. NOTICE TO CUSTOMER: PLEASE READ IMPORTANT INFORMATION ON BACK.		MISC. CHARGES	
CUSTOMER SIGNATURE		TOTAL CHARGES	
x _____		DISCOUNT	
		SALES TAX	
		PLEASE PAY THIS AMOUNT	

WARNING Motor vehicles contain chemicals known to the State of California to cause cancer and birth defects or other reproductive harm. These chemicals are contained in many vehicle components and replacement parts, vehicle fluids, and paints and materials used to maintain vehicles, including, but not limited to, fuel, oil, batteries, brakes, and wheel balancing weights. When you service, clean or maintain your car, you will be exposed to listed chemicals contained in used oil, waste and replacement fluids, fumes, grease, grime, touch-up paint, certain replacement parts, and particulates from component wear. When we service your car, we will return used components to you upon request. Used parts and component repair chemicals known to the State of California to cause cancer and birth defects or other reproductive harm. To minimize your exposure when servicing, maintaining or cleaning your vehicle: 1) work in a well ventilated area; 2) do not eat or drink; 3) avoid contact with your hands when finished or when taking a break; and 4) follow all manufacturer instructions pertaining to proper use and maintenance of motor vehicles and vehicle components. (Posted in accordance with Proposition 65 in Cal. Health & Safety Code § 25249.5(b)(3)) For further information about Proposition 65: <http://www.oehha.org/prop65.html>

CUSTOMER #:

# Bob Baker

CHRYSLER-JEEP-DODGE

Car Country Carlsbad

5515 & 5555 CAR COUNTRY DRIVE  
CARLSBAD, CALIFORNIA 92008  
(760) 431-3000

\*INVOICE\*

PAGE 4

CARLSBAD, CA

HOME: [REDACTED] CONT: N/A

BUS: [REDACTED] CELL: [REDACTED]

SERVICE ADVISOR [REDACTED]

COLOR	YEAR	MAKE/MODEL	VIN	LICENSE	MILEAGE IN / OUT	TAG	
	06	DODGE RAM15	1D7HA18K56J [REDACTED]		49280/49282	[REDACTED]	
DEL DATE	PROD DATE	WARR EXP	PROMISED	PO NO	RATE	PAYMENT	INV DATE
01JAN06 DD			17:00 22OCT10			CASH	22OCT10
R.O. OPENED	READY	OPTIONS: ENG:3.7 LITER MPI					
08:11 20OCT10	14:37 22OCT10						

LINE	OPCODE	TECH	TYPE	HOURS	LIST	NET	TOTAL
1	56049379AC		SWITCH-SPEED CONTROL				(N/C)
1	4669979		SERVO-SPEED CONTROL				(N/C)
FC: X9 PART#: COUNT:							
CLAIM TYPE: F							
AUTH CODE:							

PARTS: 0.00 LABOR: 0.00 OTHER: 0.00 TOTAL LINE F: 0.00

49282 CRUISE WILL NOT SET 14200301 (L3) X9 .5 08853003 14 .3 0.80  
 CRUISE CONTROL WILL NOT SET -MONITOR ON WIE TECH OFF AND ON SWITCH NO  
 RRESPONSE -NO VOLTAGE CHANGE FROM 4.55 VOLTS -REMOVED AIR BAG AND  
 INSTALLED NEW OFF AND ON SWITCH-- SERVO WILL NOT HOLD VACUMN--WHEN  
 TESTED--WITH HAND PUMP--REMOVED LEFT WHEEL COVER AND INSTALLED NEW  
 CRUISE CONTROL SERVO

\*\*\*\*\*  
 G\*\* CLUTCH/STARTER INTERLOCK PEDAL POSITION SWITCH  
 CAUSE: STUCK  
 23 ELECTRICAL/QUICK SERVICE  
 658 CJ 99.00 99.00  
 1 53007944AB SWITCH-CLUTCH STARTER INT 103.46 103.46 103.46  
 PARTS: 103.46 LABOR: 99.00 OTHER: 0.00 TOTAL LINE G: 202.46

49282 CLUTCH SWITCH STUCK 1.00 VEHICLE STARTS IN GEAR WITHOUT USING  
 CLUTCH ---CLUTCH SWITCH BROKEN --INSTALL NEW CLUTCH SWITCH

EST: 330.95 22OCT10 10:26 SA: 600  
 CONTACT: OK

<b>CUSTOMER SATISFACTION IS OUR TOP PRIORITY!</b> We Feature: <ul style="list-style-type: none"> <li>Rental Cars</li> <li>Latest in Diagnostic Equipment</li> <li>Expert Factory Trained Technicians</li> </ul> <b>MEMBERS OF BOB BAKER AUTOMOTIVE GROUP</b> "Where it's so Nice to be Nice" THANK YOU FOR THIS OPPORTUNITY TO SERVE YOU. WE TRUST YOU WERE SERVED IN A COURTEOUS AND PROFESSIONAL MANNER. IF YOU HAVE ANY QUESTIONS, PLEASE NOTIFY YOUR SERVICE ADVISOR IMMEDIATELY.	ORIGINAL ESTIMATE	REVISED ESTIMATE	DESCRIPTION	TOTALS
	\$	\$	LABOR AMOUNT	
			PARTS AMOUNT	
	I acknowledge notice and oral approval of an increase in the original estimated price.		GAS, OIL, LUBE	
	X _____ CUSTOMER SIGNATURE		SUBLET AMOUNT	
	SUBJECT TO THE CONDITIONS ON THE REVERSE SIDE OF THIS CONTRACT. CUSTOMER ACKNOWLEDGES RECEIPT OF A COPY HEREOF.		MISC. CHARGES	
	NOTICE TO CUSTOMER: PLEASE READ IMPORTANT INFORMATION ON BACK.		TOTAL CHARGES	
	CUSTOMER SIGNATURE		DISCOUNT	
	X _____		SALES TAX	
			<b>PLEASE PAY THIS AMOUNT</b>	

WARNING Motor vehicles contain chemicals known to the State of California to cause cancer and birth defects or other reproductive harm. These chemicals are contained in many vehicle components and replacement parts, vehicle fluids, and paints and materials used to maintain vehicles, including, but not limited to, fuel, oil, batteries, brakes, and wheel balancing weights. When you service, clean or maintain your car, you will be exposed to listed chemicals contained in used oil, waste and replacement fluids, fumes, grease, grime, touch-up paint, certain replacement parts, and particulates from component wear. When we service your car, we will return used components to you upon request. Used parts and components contain chemicals known to the State of California to cause cancer and birth defects or other reproductive harm. To minimize your exposure when servicing, maintaining or cleaning your vehicle: 1) work in a well ventilated area; 2) do not inhale fumes; 3) avoid skin contact; 4) avoid contact with eyes; 5) follow all manufacturer instructions pertaining to proper use and maintenance of motor vehicles and vehicle components. Posted in accordance with Proposition 65 in Cal. Health & Safety Code, Section 25249. For further information about Proposition 65: <http://www.cdph.org/prop65.html>

# WARRANTY

CUSTOMER #: [REDACTED]

[REDACTED]

## Bob Baker

CHRYSLER-JEEP-DODGE

Car Country Carlsbad

5515 & 5555 CAR COUNTRY DRIVE  
CARLSBAD, CALIFORNIA 92008

\*INVOICE\*

PAGE 5

CARLSBAD, CA

HOME: [REDACTED] CONT: N/A

BUS: [REDACTED] CELL: [REDACTED]

SERVICE ADVISOR [REDACTED]

COLOR	YEAR	MAKE/MODEL	VIN	LICENSE	MILEAGE IN / OUT	TAG	
	06	DODGE RAM15	1D7HA18K56J [REDACTED]		49280/49282 [REDACTED]		
DEL. DATE	PROD. DATE	WARR. EXP.	PROMISED	PO NO.	RATE	PAYMENT	INV. DATE
01JAN06 DD			17:00 22OCT10			CASH	22OCT10
R.O. OPENED	READY	OPTIONS: ENG:3.7_LITER_MPI					
08:11 20OCT10	14:37 22OCT10						

LINE	OPCODE	TECH	TYPE	HOURS	LIST	NET	TOTAL
PROPER EXPLANATION OF REPAIR HAS BEEN COMPLETED.							

SERVICE HOURS 7:00am to 6:00PM MON thru FRI  
8:00am to NOON SATURDAY

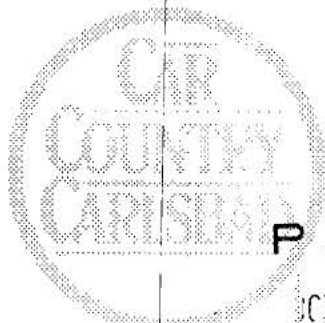

PAID

OCT 22 2008

*Asman*

CUSTOMER PAY DEDUCTIBLE FOR LINE A

100.00

CUSTOMER SATISFACTION IS OUR TOP PRIORITY!

We Feature:

- Rental Cars
- Latest in Diagnostic Equipment
- Expert Factory Trained Technicians

**MEMBERS OF BOB BAKER  
AUTOMOTIVE GROUP**

"Where it's so Nice to be Nice"

THANK YOU FOR THIS OPPORTUNITY TO SERVE YOU. WE TRUST YOU WERE SERVED IN A COURTEOUS AND PROFESSIONAL MANNER. IF YOU HAVE ANY QUESTIONS, PLEASE NOTIFY YOUR SERVICE ADVISOR IMMEDIATELY.

ORIGINAL ESTIMATE	REVISED ESTIMATE	DESCRIPTION	TOTALS
\$ 120 -	\$ 330 -	LABOR AMOUNT	102.26
		PARTS AMOUNT	128.01
		GAS, OIL, LUBE	0.00
		SUBLET AMOUNT	0.00
		MISC. CHARGES	100.00
		TOTAL CHARGES	330.27
		DISCOUNT	0.00
		SALES TAX	11.20
		PLEASE PAY THIS AMOUNT	341.47

WARNING Motor vehicles contain chemicals known to the State of California to cause cancer and birth defects or other reproductive harm. These chemicals are contained in many vehicle components and replacement parts; vehicle fluids, and paints and materials used to maintain vehicles, including, but not limited to, fuel, oil, batteries, brakes, and wheel balancing weights. When you service, clean or maintain your car, you will be exposed to listed chemicals contained in used oil, waste and replacement fluids, fumes, grease, grime, touch-up paint, certain replacement parts, and particulates from component wear. When we service your car, we will return used components to you upon request. Used parts and components contain chemicals known to the State of California to cause cancer and birth defects or other reproductive harm. To minimize your exposure when servicing, maintaining or cleaning your vehicle: 1) work in a well ventilated area; 2) do not eat or drink; 3) do not use open flames or sparks; 4) do not use compressed air to clean your face or clothing; 5) do not use compressed air to clean your skin; 6) do not use compressed air to clean your eyes; 7) do not use compressed air to clean your mouth; 8) do not use compressed air to clean your hair; 9) do not use compressed air to clean your clothes; 10) do not use compressed air to clean your shoes; 11) do not use compressed air to clean your hands when finished or when taking a break; and 12) follow all manufacturer instructions pertaining to proper use and maintenance of motor vehicles and vehicle components. Posted in accordance with Proposition 65 in Cal. Health & Safety Code, Section 25249.5. For more information about Proposition 65, visit <http://www.cdph.ca.gov/prop65.html>.

Oceanside, CA



RECEIVED  
NOV 29 2010  
By

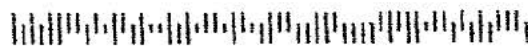
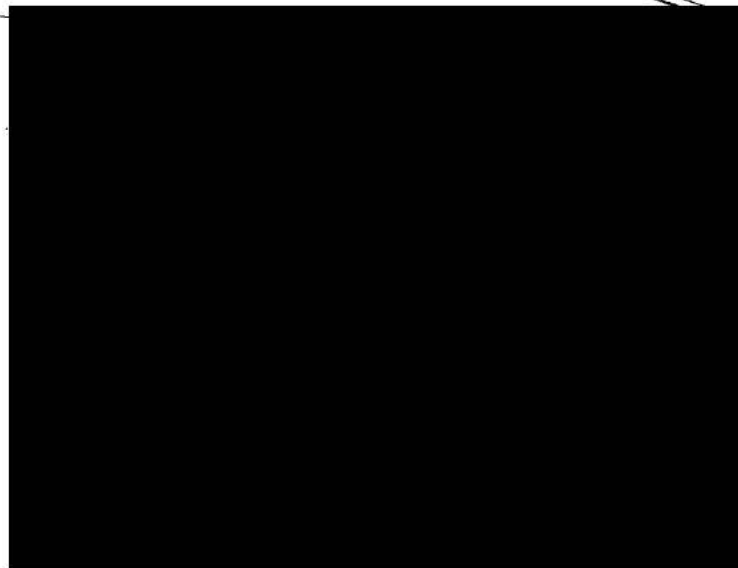

PE14-013

CHRYSLER

8-11-2014

ENCLOSURE 6

Field Reports PUBLIC

CUSTOMER COMPLAINTS

PEER VEHICLE REPORTS

73 BY CHRYSLER LLC

DATE OF MFG  
4-08

GVWR  
4522 KG (10100 LB)

DRIVE FRONT

2258 KG (5000 LB)

WITH TIRES

LT265/70R17E

RTWG WT

17X8.0

RTWS WT

17X8.0

CSL3

410 KPA (60 PSI)

CSL3

520 KPA (75 PSI)

DRIVE REAR

2813 KG (6200 LB)

WITH TIRES

LT265/70R17E

THIS VEHICLE COMPLIES TO ALL APPLICABLE U.S.A. FEDERAL MOTOR VEHICLE SAFETY STANDARDS IN EFFECT ON THE DATE OF MANUFACTURE SHOWN ABOVE.

VIN

3D7YK36A6E

TYPE

TRUCK

SINGLE N. TRAIL



MPN

041122 664PB PNT:NR

VEHICLE TYPE BY MANUFACTURER



 Bradford Built-























12V-30A











ARCTIC CAT

PATH OF TRUCK



**SKID MARKS MADE BY  
RIGHT REAR TIRE**

A photograph of asphalt pavement showing several dark, irregular skid marks. The marks are most prominent in the center-left area. There are also some white and red debris scattered on the surface. A concrete expansion joint runs horizontally across the upper portion of the image. In the bottom right corner, a portion of a black tire is visible.

**SKID MARKS MADE  
BY LEFT REAR TIRE**



**MINOR IMPACT  
DAMAGE**





























Bradford Built







PE14-013

CHRYSLER

8-11-2014

ENCLOSURE 6

Field Reports PUBLIC

CUSTOMER COMPLAINTS

PEER VEHICLE REPORTS

From: [REDACTED]  
To: [REDACTED]  
Date: Sat May 24 15:08:03 EDT 2014  
Subject: Chrysler Group LLC Customer Assistance  
Form Selected:

-----  
Category: Recall Information

Brief Description:

-----  
Clutch safety switch

Comments:

-----  
My vehicle starts without pressing the clutch. Why was I never notified by Dodge/Ram etc... about this recall.

Sender Information:

-----  
Title:

First Name: [REDACTED]  
[REDACTED]  
[REDACTED]

From: [REDACTED]

To: [REDACTED]

Date: Wed May 28 04:38:10 EDT 2014

Subject: Re: Chrysler Group LLC Customer Assistance

Dear [REDACTED]

Thank you for contacting the RAM Customer Assistance Center.

I regret the problem your vehicle has experienced and appreciate the time and effort you took to bring this matter to our attention.

Unfortunately, we are unable to diagnose your vehicle's problem via email. We recommend contacting your authorized dealership to arrange an appointment for proper diagnosis and repair. Our dealerships have the factory training, equipment and information available to them to diagnose and correct problems with our vehicles. Should your dealer require technical assistance they may contact our Technical Operations Resource Group or contact their regional Business Center.

Finding a dealer is simple;

You can find a dealership by visiting our Ram brand website at Ram - <http://www.ramtrucks.com>.

Thank you again for your email. Should you require additional assistance, or have any new information to provide, please reply to this email message or call [REDACTED]

Sincerely,

[REDACTED]  
Customer Service Representative  
RAM Customer Assistance Center

For any future communications related to this email, please refer to the following information:

REFERENCE NUMBER: [REDACTED]

EMAIL CASE NUMBER: [REDACTED]

REPLY LINK:  
[REDACTED]

Original Message Follows:

-----  
Recall Information - Ram Brand Site

Brief Description:

Clutch safety switch

Comments:

My vehicle starts without pressing the clutch. Why was I never notified by Dodge/Ram etc... about this recall.

VIN:

6J [REDACTED]

Mileage:

70545

Servicing Dealer:

Title:

First Name:

[REDACTED]  
[REDACTED]

[REDACTED]

[REDACTED]

[REDACTED]

[REDACTED]

Address 2:

City:

West Park

State:

FL

Zip:

[REDACTED]

[REDACTED]

[REDACTED]

[REDACTED]

[REDACTED]

From: [REDACTED]

To: [REDACTED]

[REDACTED]

Subject: Reply to Chrysler Group LLC ([REDACTED])

Reply Comments:

-----

Is the repair going to be free of charge

From: [REDACTED]

To: [REDACTED]

Date: Wed May 28 23:58:52 EDT 2014

Subject: Re: Reply to Chrysler Group LLC [REDACTED]

Dear [REDACTED]:

Thank you for contacting the RAM Customer Assistance Center.

In regards to your vehicle, we fully appreciate your concern, particularly in view of the expense and inconvenience involved, however, we are unable to accommodate your request for out-of-warranty consideration. The vehicle has exceeded the time and/or mileage limitations of the warranty (or warranties) we offered on the vehicle at the time it was purchased. Although we are unable to provide a more favorable reply, we appreciate the opportunity to review your request. We're sorry we cannot provide a more favorable reply.

Thank you again for your email. Should you require additional assistance, or have any new information to provide, please reply to this email message or call [REDACTED]

[REDACTED].

Sincerely,

[REDACTED]

Customer Service Representative

RAM Customer Assistance Center

For any future communications related to this email, please refer to the following information:

REFERENCE NUMBER: [REDACTED]

EMAIL CASE NUMBER: [REDACTED]

REPLY LINK:

[http://www.chrysler.com/wccs/brand\\_forms/us/reply.jsp?trk\\_ID=K\[REDACTED\]&](http://www.chrysler.com/wccs/brand_forms/us/reply.jsp?trk_ID=K[REDACTED]&)

Original Message Follows:

-----

Comments:

Is the repair going to be free of charge