



---

**From:** [REDACTED]  
**Sent:** Tuesday, May 06, 2014 2:22 PM  
**To:** [REDACTED]  
**Cc:**  
**Subject:**  
**Attachments:** [REDACTED]

[REDACTED] per our discussion, for customer care contact to retrieve the vehicle connectors. 2xNissan Leafs

---

**From:** [REDACTED]  
**Sent:** Tuesday, April 29, 2014 4:15 PM  
**To:** [REDACTED]  
**Subject:** Power Xpress - 148766

[REDACTED]

Here is some pictures from this customer claimed the plug is deformed. Let me know if you have a question.

Contact [REDACTED]  
Phone [REDACTED]  
Email: [REDACTED]

[REDACTED]  
Seattle, WA [REDACTED].

Sales Order Number: 774338 or ESS Request: 16046  
Make and Model of the Vehicle: 2013 NISSAN LEAF  
Serial Number of EVSE: [REDACTED]  
How is the vehicle responding (Dash LED or other charge indicator)?  
How are the EVSE LEDs responding: OFF

- Power: GREEN
- Status: AMBER
- If Flash red (PILOT CHARGING ERROR, GROUND MONITOR INTERRUPTED):NA

NOTE: SATURDAY WAS UNABLE TO REMOVE THE PLUG FROM THE VEHICLE, THEN HE WIGGLE IT, THE NIGHT BEFORE HIS WIFE TOLD HIM THE PLUG FEELS MORE HOT THAN USUAL. HE NOTICED THE PLUG IS DEFORMED, NOW HE HAD TO FORCE IT INTO THE 2ND NISSAN LEAF TO GET IT PLUGGED IN.

Is the EVSE on a dedicated circuit? NA  
Has the Reset button been reset? NA  
Has the breaker to the EVSE been reset? NA  
Can we confirm the circuit is good, 240V to the unit? NOT SURE (ISC INSTALL IT)  
Who Performed Installation? (Self-Install or their own "licensed" electrician or, Bosch Installer – Please list one) BOSCH INSTALLER  
Is it hardwired (Directly to the EVSE) or plug mount? HARDWIRED  
Is it a permitted install? – Only if self-install, Bosch install will be permitted. PERMITTED INSTALL  
Did this failure occur on new installation or was the unit working then failed? the unit working then failed  
Can they charge with another EVSE, Level 1 or another Level 2? YES.

---

**From:** AA-AS oetech (Automotive-Service-Solutions)  
**Sent:** Tuesday, April 29, 2014 4:15 PM  
**To:** [REDACTED]  
**Subject:** Power Xpress - 148766  
**Attachments:** photo1.jpg; photo2.jpg; photo3.jpg; photo4.jpg; photo5.jpg; photo6.jpg; photo7.jpg; photo8.jpg; photo9.jpg; photo10.jpg; photo11.jpg; photo12.jpg; photo13.jpg; photo14.jpg; photo15.jpg

[REDACTED]

Here is some pictures from this customer claimed the plug is deformed. Let me know if you have a question.

Contact [REDACTED]  
Phone [REDACTED]  
Email: [REDACTED]

[REDACTED]

Seattle, WA [REDACTED]

Sales Order Number: 774338 or ESS Request: 16046

Make and Model of the Vehicle: 2013 NISSAN LEAF

Serial Number of EVSE: [REDACTED]

How is the vehicle responding (Dash LED or other charge indicator)?

How are the EVSE LEDs responding: OFF

- Power: GREEN
- Status: AMBER
- If Flash red (PILOT CHARGING ERROR, GROUND MONITOR INTERRUPTED):NA

NOTE: SATURDAY WAS UNABLE TO REMOVE THE PLUG FROM THE VEHICLE, THEN HE WIGGLE IT, THE NIGHT BEFORE HIS WIFE TOLD HIM THE PLUG FEELS MORE HOT THAN USUAL. HE NOTICED THE PLUG IS DEFORMED, NOW HE HAD TO FORCE IT INTO THE 2ND NISSAN LEAF TO GET IT PLUGGED IN.

Is the EVSE on a dedicated circuit? NA

Has the Reset button been reset? NA

Has the breaker to the EVSE been reset? NA

Can we confirm the circuit is good, 240V to the unit? NOT SURE (ISC INSTALL IT)

Who Performed Installation? (Self-Install or their own "licensed" electrician or, Bosch Installer – Please list one) BOSCH INSTALLER

Is it hardwired (Directly to the EVSE) or plug mount? HARDWIRED

Is it a permitted install? – Only if self-install, Bosch install will be permitted. PERMITTED INSTALL

Did this failure occur on new installation or was the unit working then failed? the unit working then failed

Can they charge with another EVSE, Level 1 or another Level 2? YES.

# OUTPUT SPECIFICATIONS

MANUFACTURER: SPX CORPORATION  
CATALOG #: EL-50600-A  
PART#: EV20H25318U  
VOLTAGE: 208/240 VAC  
FREQUENCY: 50-60HZ (~)  
AMPERAGE: 30 AMP MAX  
WATTAGE: 7200W MAX  
MGF DATE CODE: 2012/01/28  
SERIAL NUMBER: [REDACTED]

REV. 4



US

CONFORMS TO  
UL STD. 2231-1,  
UL STD 2231-2,  
UL SUB 2594

CERTIFIED TO  
CSA STD. C22.2  
NO. 107.1

Intertek  
4002333

LOAD CURRENT DIRECTION





PE14-011BOSCH0777



PE14-011BOSCH0778

PE14-011BOSCH0778



PE14-Q11BOSCH0779



© 2014 Bosch Power Tools  
All rights reserved. Bosch Power Tools  
is a registered trademark of Robert Bosch  
GmbH. Bosch Power Tools is a registered  
trademark of Bosch Power Tools Inc.

PE14-011BOSCH0780



Small white label with illegible text, possibly a manufacturer's mark or identification tag.

PE14-011BOSCH0781



PE14-011BOSCH0782



PE14-011BOSCH0783



PE14-011BOSCH0784



PE14-011BOSCH0785

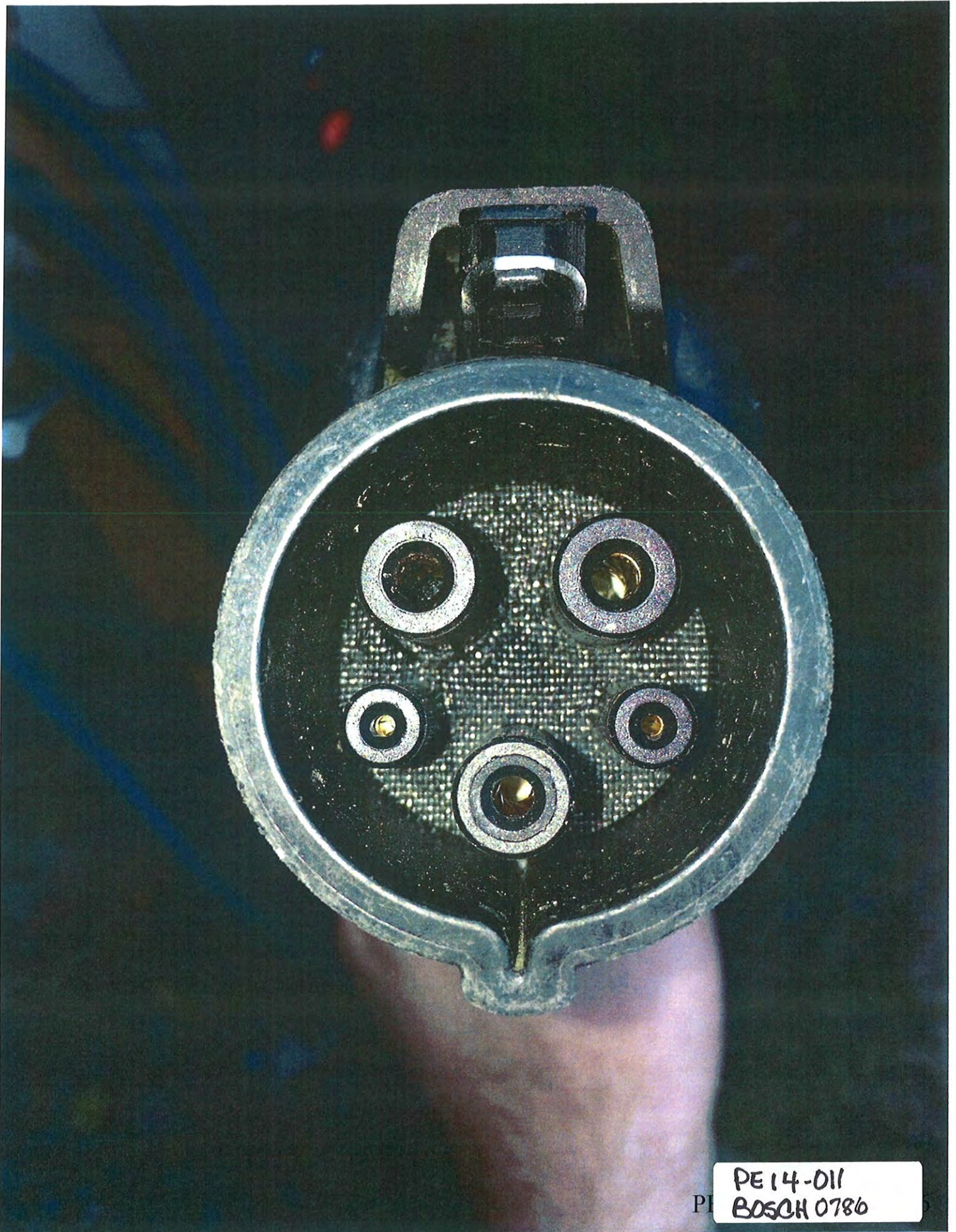

PE14-011  
BOSCH 0786

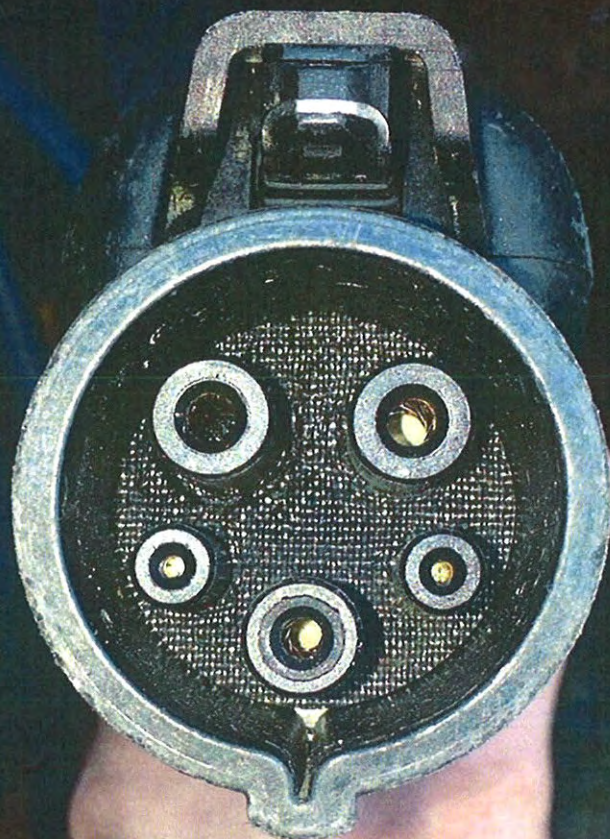

PE14-011BOSCH0787

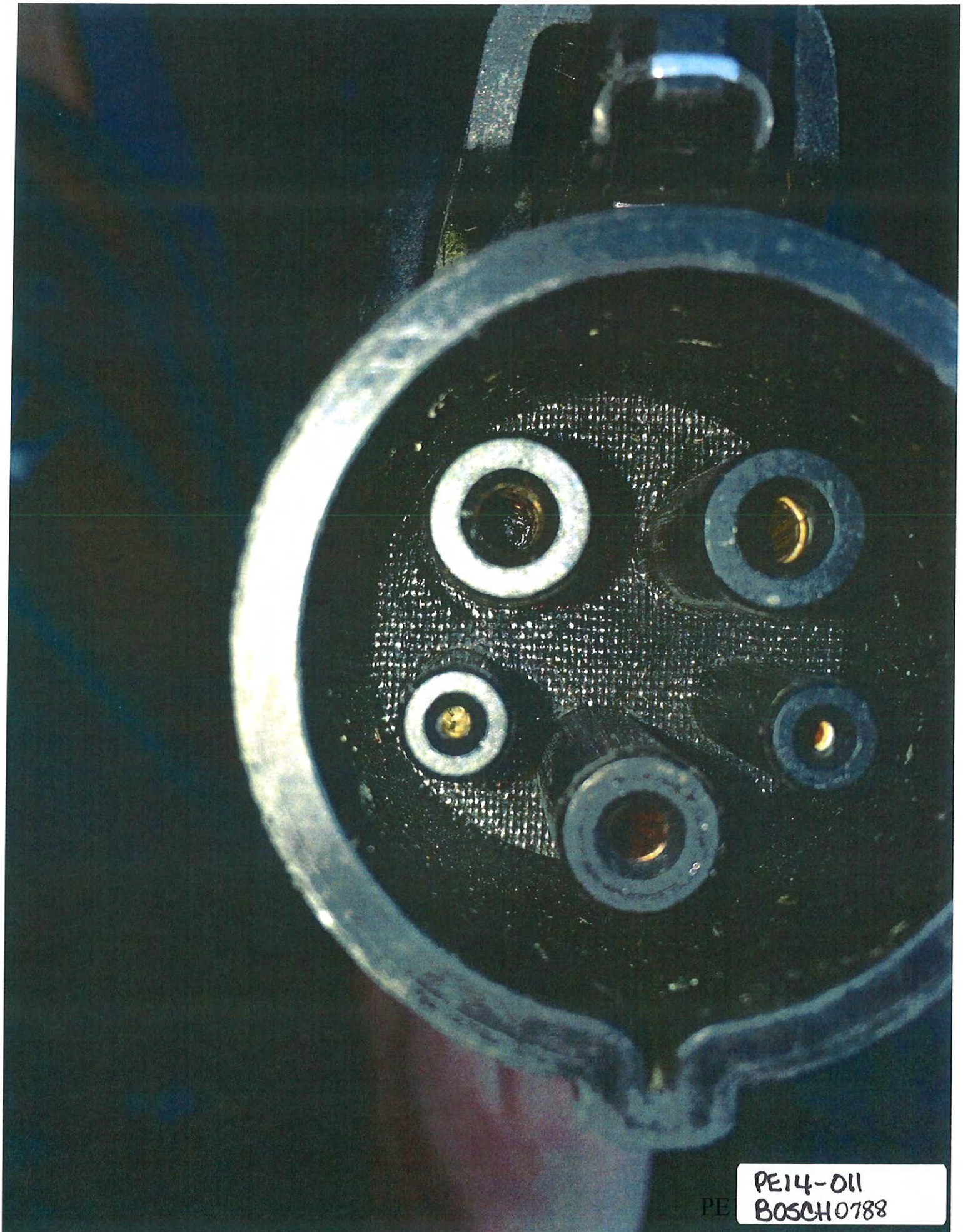

PE14-011  
PE BOSCH 0788



PE14-011  
BOSCH 0789

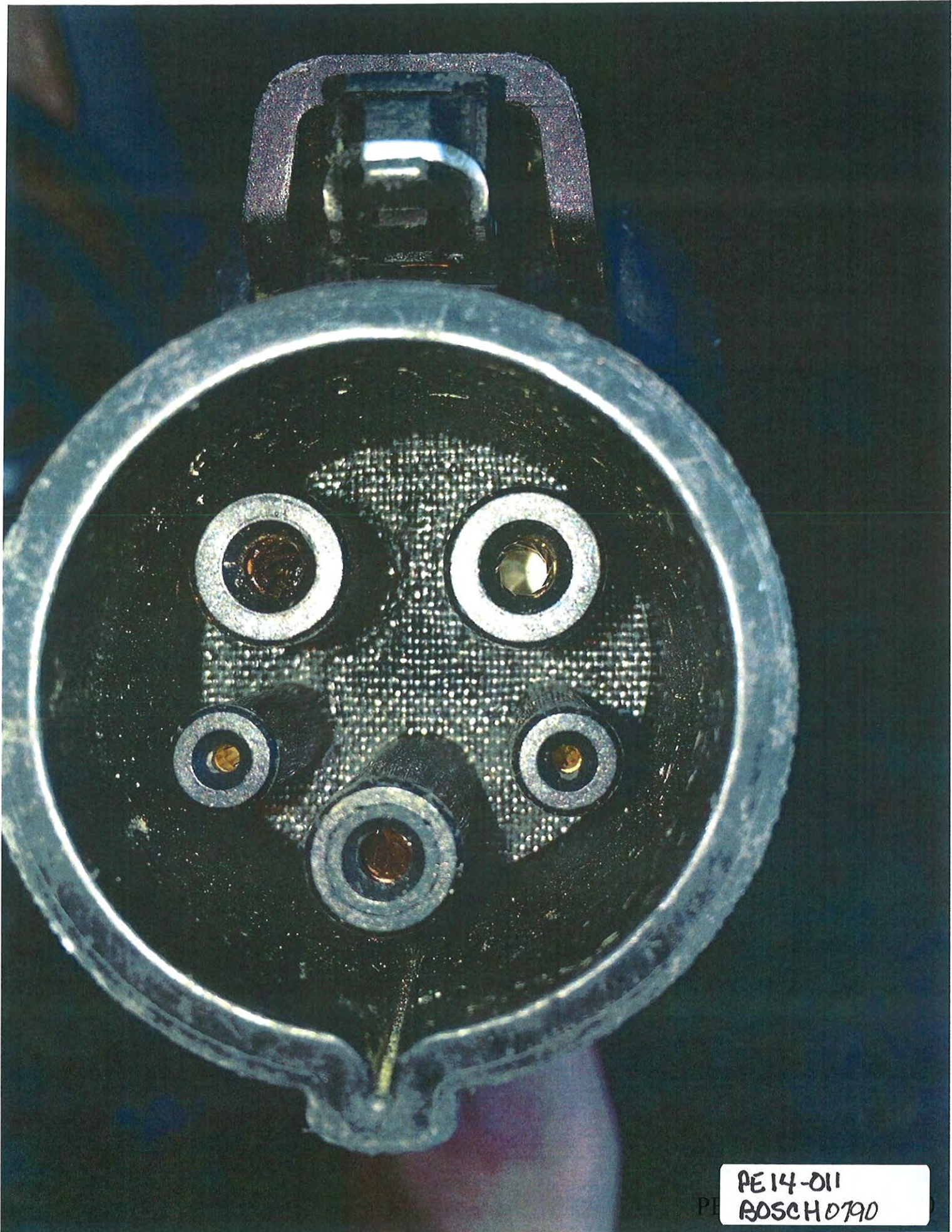

PE14-011  
BOSCH 0790



---

**From:** [REDACTED]  
**Sent:** Saturday, May 10, 2014 10:12 AM  
**To:** [REDACTED]  
**Cc:** [REDACTED]  
**Subject:** Re: SPX Power Xpress plug Issues

[REDACTED]

Thanks for repairing the charger yesterday. The new one looks great.

Bosch has asked that I return the old plug to them so that they may analyze it. I don't see it anywhere, though. Do you still have it? If so, could you keep it so that you or I could return it to them?

Thanks.

[REDACTED]

[REDACTED]



---

**From:** [REDACTED]  
**Sent:** Thursday, May 15, 2014 9:33 AM  
**To:** [REDACTED]  
**Subject:** RE: Summary of Agreements with Bosch  
**Attachments:** W-9 Form.pdf

Good morning [REDACTED]  
Attached is the W-9 Form I promised. We'll talk when you return next week.

Thanks!

Mit freundlichen Grüßen / Best regards,

[REDACTED]  
Program Manager - EV Solutions  
Bosch Automotive Service Solutions (AA-AS)

[REDACTED]

The information contained in this electronic mail transmission is intended by Robert Bosch GmbH for the use of the named individual or entity to which it is directed and may contain information that is confidential or privileged. If you have received this electronic mail transmission in error, please delete it from your system without copying or forwarding it, and notify the sender of the error by reply email so that the sender's address records can be corrected.

---

**From:** [REDACTED]  
**Sent:** Saturday, May 10, 2014 9:44 AM  
**To:** [REDACTED]  
**Subject:** Summary of Agreements with Bosch

Good morning [REDACTED]  
Per our conversation a few days back, the following denotes the agreements we discussed to ensure a timely resolution regarding the issue you encountered with the Power Xpress connector:

1. You will be receiving a replacement Power Xpress cord/connector within the next few days. We'll send you a shipping label so you can return the one you currently have in your possession.
2. Please provide us with a detailed quotation from your Nissan dealership for the repair/replacement of the vehicle inlet connectors on your two (2) Nissan Leaf vehicles. We'll pay the dealer direct via credit card within ten (10) days of the return of the signed Agreement that's attached for your review. We'll also send you a shipping label so you can return the replaced vehicle parts to us.
3. We will forward you the IRS W-9 form on Monday.

Looking forward to working with you and please contact me via the information below if you have any questions.

Thanks and have a great weekend.

Mit freundlichen Grüßen / Best regards,

  
Program Manager - EV Solutions  
Bosch Automotive Service Solutions (AA-AS)

  
The information contained in this electronic mail transmission is intended by Robert Bosch GmbH for the use of the named individual or entity to which it is directed and may contain information that is confidential or privileged. If you have received this electronic mail transmission in error, please delete it from your system without copying or forwarding it, and notify the sender of the error by reply email so that the sender's address records can be corrected.

## Request for Taxpayer Identification Number and Certification

**Give Form to the  
 requester. Do not  
 send to the IRS.**

Print or type See Specific Instructions on page 2.	Name (as shown on your income tax return)	
	Business name/disregarded entity name, if different from above	
	Check appropriate box for federal tax classification: <input type="checkbox"/> Individual/sole proprietor <input type="checkbox"/> C Corporation <input type="checkbox"/> S Corporation <input type="checkbox"/> Partnership <input type="checkbox"/> Trust/estate  <input type="checkbox"/> Limited liability company. Enter the tax classification (C=C corporation, S=S corporation, P=partnership) ▶ _____  <input type="checkbox"/> Other (see instructions) ▶ _____	Exemptions (see instructions):  Exempt payee code (if any) _____ Exemption from FATCA reporting code (if any) _____
	Address (number, street, and apt. or suite no.)	Requester's name and address (optional)
	City, state, and ZIP code	
List account number(s) here (optional)		

### Part I Taxpayer Identification Number (TIN)

Enter your TIN in the appropriate box. The TIN provided must match the name given on the "Name" line to avoid backup withholding. For individuals, this is your social security number (SSN). However, for a resident alien, sole proprietor, or disregarded entity, see the Part I instructions on page 3. For other entities, it is your employer identification number (EIN). If you do not have a number, see *How to get a TIN* on page 3.

Social security number								

**Note.** If the account is in more than one name, see the chart on page 4 for guidelines on whose number to enter.

Employer identification number								

### Part II Certification

Under penalties of perjury, I certify that:

1. The number shown on this form is my correct taxpayer identification number (or I am waiting for a number to be issued to me), and
2. I am not subject to backup withholding because: (a) I am exempt from backup withholding, or (b) I have not been notified by the Internal Revenue Service (IRS) that I am subject to backup withholding as a result of a failure to report all interest or dividends, or (c) the IRS has notified me that I am no longer subject to backup withholding, and
3. I am a U.S. citizen or other U.S. person (defined below), and
4. The FATCA code(s) entered on this form (if any) indicating that I am exempt from FATCA reporting is correct.

**Certification instructions.** You must cross out item 2 above if you have been notified by the IRS that you are currently subject to backup withholding because you have failed to report all interest and dividends on your tax return. For real estate transactions, item 2 does not apply. For mortgage interest paid, acquisition or abandonment of secured property, cancellation of debt, contributions to an individual retirement arrangement (IRA), and generally, payments other than interest and dividends, you are not required to sign the certification, but you must provide your correct TIN. See the instructions on page 3.

<b>Sign Here</b>	Signature of U.S. person ▶	Date ▶
------------------	----------------------------	--------

### General Instructions

Section references are to the Internal Revenue Code unless otherwise noted.  
**Future developments.** The IRS has created a page on [www.irs.gov/w9](http://www.irs.gov/w9) for information about Form W-9, at [www.irs.gov/w9](http://www.irs.gov/w9). Information about any future developments affecting Form W-9 (such as legislation enacted after we release it) will be posted on that page.

#### Purpose of Form

A person who is required to file an information return with the IRS must obtain your correct taxpayer identification number (TIN) to report, for example, income paid to you, payments made to you in settlement of payment card and third party network transactions, real estate transactions, mortgage interest you paid, acquisition or abandonment of secured property, cancellation of debt, or contributions you made to an IRA.

Use Form W-9 only if you are a U.S. person (including a resident alien), to provide your correct TIN to the person requesting it (the requester) and, when applicable, to:

1. Certify that the TIN you are giving is correct (or you are waiting for a number to be issued),
2. Certify that you are not subject to backup withholding, or
3. Claim exemption from backup withholding if you are a U.S. exempt payee. If applicable, you are also certifying that as a U.S. person, your allocable share of any partnership income from a U.S. trade or business is not subject to the

withholding tax on foreign partners' share of effectively connected income, and

4. Certify that FATCA code(s) entered on this form (if any) indicating that you are exempt from the FATCA reporting, is correct.

**Note.** If you are a U.S. person and a requester gives you a form other than Form W-9 to request your TIN, you must use the requester's form if it is substantially similar to this Form W-9.

**Definition of a U.S. person.** For federal tax purposes, you are considered a U.S. person if you are:

- An individual who is a U.S. citizen or U.S. resident alien,
- A partnership, corporation, company, or association created or organized in the United States or under the laws of the United States,
- An estate (other than a foreign estate), or
- A domestic trust (as defined in Regulations section 301.7701-7).

**Special rules for partnerships.** Partnerships that conduct a trade or business in the United States are generally required to pay a withholding tax under section 1446 on any foreign partners' share of effectively connected taxable income from such business. Further, in certain cases where a Form W-9 has not been received, the rules under section 1446 require a partnership to presume that a partner is a foreign person, and pay the section 1446 withholding tax. Therefore, if you are a U.S. person that is a partner in a partnership conducting a trade or business in the United States, provide Form W-9 to the partnership to establish your U.S. status and avoid section 1446 withholding on your share of partnership income.

In the cases below, the following person must give Form W-9 to the partnership for purposes of establishing its U.S. status and avoiding withholding on its allocable share of net income from the partnership conducting a trade or business in the United States:

- In the case of a disregarded entity with a U.S. owner, the U.S. owner of the disregarded entity and not the entity,
- In the case of a grantor trust with a U.S. grantor or other U.S. owner, generally, the U.S. grantor or other U.S. owner of the grantor trust and not the trust, and
- In the case of a U.S. trust (other than a grantor trust), the U.S. trust (other than a grantor trust) and not the beneficiaries of the trust.

**Foreign person.** If you are a foreign person or the U.S. branch of a foreign bank that has elected to be treated as a U.S. person, do not use Form W-9. Instead, use the appropriate Form W-8 or Form 8233 (see Publication 515, Withholding of Tax on Nonresident Aliens and Foreign Entities).

**Nonresident alien who becomes a resident alien.** Generally, only a nonresident alien individual may use the terms of a tax treaty to reduce or eliminate U.S. tax on certain types of income. However, most tax treaties contain a provision known as a "saving clause." Exceptions specified in the saving clause may permit an exemption from tax to continue for certain types of income even after the payee has otherwise become a U.S. resident alien for tax purposes.

If you are a U.S. resident alien who is relying on an exception contained in the saving clause of a tax treaty to claim an exemption from U.S. tax on certain types of income, you must attach a statement to Form W-9 that specifies the following five items:

1. The treaty country. Generally, this must be the same treaty under which you claimed exemption from tax as a nonresident alien.
2. The treaty article addressing the income.
3. The article number (or location) in the tax treaty that contains the saving clause and its exceptions.
4. The type and amount of income that qualifies for the exemption from tax.
5. Sufficient facts to justify the exemption from tax under the terms of the treaty article.

**Example.** Article 20 of the U.S.-China income tax treaty allows an exemption from tax for scholarship income received by a Chinese student temporarily present in the United States. Under U.S. law, this student will become a resident alien for tax purposes if his or her stay in the United States exceeds 5 calendar years. However, paragraph 2 of the first Protocol to the U.S.-China treaty (dated April 30, 1984) allows the provisions of Article 20 to continue to apply even after the Chinese student becomes a resident alien of the United States. A Chinese student who qualifies for this exception (under paragraph 2 of the first protocol) and is relying on this exception to claim an exemption from tax on his or her scholarship or fellowship income would attach to Form W-9 a statement that includes the information described above to support that exemption.

If you are a nonresident alien or a foreign entity, give the requester the appropriate completed Form W-8 or Form 8233.

**What is backup withholding?** Persons making certain payments to you must under certain conditions withhold and pay to the IRS a percentage of such payments. This is called "backup withholding." Payments that may be subject to backup withholding include interest, tax-exempt interest, dividends, broker and barter exchange transactions, rents, royalties, nonemployee pay, payments made in settlement of payment card and third party network transactions, and certain payments from fishing boat operators. Real estate transactions are not subject to backup withholding.

You will not be subject to backup withholding on payments you receive if you give the requester your correct TIN, make the proper certifications, and report all your taxable interest and dividends on your tax return.

### Payments you receive will be subject to backup withholding if:

1. You do not furnish your TIN to the requester,
2. You do not certify your TIN when required (see the Part II Instructions on page 3 for details),
3. The IRS tells the requester that you furnished an incorrect TIN,
4. The IRS tells you that you are subject to backup withholding because you did not report all your interest and dividends on your tax return (for reportable interest and dividends only), or
5. You do not certify to the requester that you are not subject to backup withholding under 4 above (for reportable interest and dividend accounts opened after 1983 only).

Certain payees and payments are exempt from backup withholding. See *Exempt payee code* on page 3 and the separate Instructions for the Requester of Form W-9 for more information.

Also see *Special rules for partnerships* on page 1.

**What is FATCA reporting?** The Foreign Account Tax Compliance Act (FATCA) requires a participating foreign financial institution to report all United States account holders that are specified United States persons. Certain payees are exempt from FATCA reporting. See *Exemption from FATCA reporting code* on page 3 and the Instructions for the Requester of Form W-9 for more information.

## Updating Your Information

You must provide updated information to any person to whom you claimed to be an exempt payee if you are no longer an exempt payee and anticipate receiving reportable payments in the future from this person. For example, you may need to provide updated information if you are a C corporation that elects to be an S corporation, or if you no longer are tax exempt. In addition, you must furnish a new Form W-9 if the name or TIN changes for the account, for example, if the grantor of a grantor trust dies.

## Penalties

**Failure to furnish TIN.** If you fail to furnish your correct TIN to a requester, you are subject to a penalty of \$50 for each such failure unless your failure is due to reasonable cause and not to willful neglect.

**Civil penalty for false information with respect to withholding.** If you make a false statement with no reasonable basis that results in no backup withholding, you are subject to a \$500 penalty.

**Criminal penalty for falsifying information.** Willfully falsifying certifications or affirmations may subject you to criminal penalties including fines and/or imprisonment.

**Misuse of TINs.** If the requester discloses or uses TINs in violation of federal law, the requester may be subject to civil and criminal penalties.

## Specific Instructions

### Name

If you are an individual, you must generally enter the name shown on your income tax return. However, if you have changed your last name, for instance, due to marriage without informing the Social Security Administration of the name change, enter your first name, the last name shown on your social security card, and your new last name.

If the account is in joint names, list first, and then circle, the name of the person or entity whose number you entered in Part I of the form.

**Sole proprietor.** Enter your individual name as shown on your income tax return on the "Name" line. You may enter your business, trade, or "doing business as (DBA)" name on the "Business name/disregarded entity name" line.

**Partnership, C Corporation, or S Corporation.** Enter the entity's name on the "Name" line and any business, trade, or "doing business as (DBA) name" on the "Business name/disregarded entity name" line.

**Disregarded entity.** For U.S. federal tax purposes, an entity that is disregarded as an entity separate from its owner is treated as a "disregarded entity." See Regulation section 301.7701-2(c)(2)(iii). Enter the owner's name on the "Name" line. The name of the entity entered on the "Name" line should never be a disregarded entity. The name on the "Name" line must be the name shown on the income tax return on which the income should be reported. For example, if a foreign LLC that is treated as a disregarded entity for U.S. federal tax purposes has a single owner that is a U.S. person, the U.S. owner's name is required to be provided on the "Name" line. If the direct owner of the entity is also a disregarded entity, enter the first owner that is not disregarded for federal tax purposes. Enter the disregarded entity's name on the "Business name/disregarded entity name" line. If the owner of the disregarded entity is a foreign person, the owner must complete an appropriate Form W-8 instead of a Form W-9. This is the case even if the foreign person has a U.S. TIN.

**Note.** Check the appropriate box for the U.S. federal tax classification of the person whose name is entered on the "Name" line (Individual/sole proprietor, Partnership, C Corporation, S Corporation, Trust/estate).

**Limited Liability Company (LLC).** If the person identified on the "Name" line is an LLC, check the "Limited liability company" box only and enter the appropriate code for the U.S. federal tax classification in the space provided. If you are an LLC that is treated as a partnership for U.S. federal tax purposes, enter "P" for partnership. If you are an LLC that has filed a Form 8832 or a Form 2553 to be taxed as a corporation, enter "C" for C corporation or "S" for S corporation, as appropriate. If you are an LLC that is disregarded as an entity separate from its owner under Regulation section 301.7701-3 (except for employment and excise tax), do not check the LLC box unless the owner of the LLC (required to be identified on the "Name" line) is another LLC that is not disregarded for U.S. federal tax purposes. If the LLC is disregarded as an entity separate from its owner, enter the appropriate tax classification of the owner identified on the "Name" line.

**Other entities.** Enter your business name as shown on required U.S. federal tax documents on the "Name" line. This name should match the name shown on the charter or other legal document creating the entity. You may enter any business, trade, or DBA name on the "Business name/disregarded entity name" line.

## Exemptions

If you are exempt from backup withholding and/or FATCA reporting, enter in the *Exemptions* box, any code(s) that may apply to you. See *Exempt payee code* and *Exemption from FATCA reporting code* on page 3.

**Exempt payee code.** Generally, individuals (including sole proprietors) are not exempt from backup withholding. Corporations are exempt from backup withholding for certain payments, such as interest and dividends. Corporations are not exempt from backup withholding for payments made in settlement of payment card or third party network transactions.

**Note.** If you are exempt from backup withholding, you should still complete this form to avoid possible erroneous backup withholding.

The following codes identify payees that are exempt from backup withholding:

- 1—An organization exempt from tax under section 501(a), any IRA, or a custodial account under section 403(b)(7) if the account satisfies the requirements of section 401(f)(2)
- 2—The United States or any of its agencies or instrumentalities
- 3—A state, the District of Columbia, a possession of the United States, or any of their political subdivisions or instrumentalities
- 4—A foreign government or any of its political subdivisions, agencies, or instrumentalities
- 5—A corporation
- 6—A dealer in securities or commodities required to register in the United States, the District of Columbia, or a possession of the United States
- 7—A futures commission merchant registered with the Commodity Futures Trading Commission
- 8—A real estate investment trust
- 9—An entity registered at all times during the tax year under the Investment Company Act of 1940
- 10—A common trust fund operated by a bank under section 584(a)
- 11—A financial institution
- 12—A middleman known in the investment community as a nominee or custodian
- 13—A trust exempt from tax under section 664 or described in section 4947

The following chart shows types of payments that may be exempt from backup withholding. The chart applies to the exempt payees listed above, 1 through 13.

IF the payment is for . . .	THEN the payment is exempt for . . .
Interest and dividend payments	All exempt payees except for 7
Broker transactions	Exempt payees 1 through 4 and 6 through 11 and all C corporations. S corporations must not enter an exempt payee code because they are exempt only for sales of noncovered securities acquired prior to 2012.
Barter exchange transactions and patronage dividends	Exempt payees 1 through 4
Payments over \$600 required to be reported and direct sales over \$5,000 <sup>1</sup>	Generally, exempt payees 1 through 5 <sup>2</sup>
Payments made in settlement of payment card or third party network transactions	Exempt payees 1 through 4

<sup>1</sup> See Form 1099-MISC, Miscellaneous Income, and its instructions.

<sup>2</sup> However, the following payments made to a corporation and reportable on Form 1099-MISC are not exempt from backup withholding: medical and health care payments, attorneys' fees, gross proceeds paid to an attorney, and payments for services paid by a federal executive agency.

**Exemption from FATCA reporting code.** The following codes identify payees that are exempt from reporting under FATCA. These codes apply to persons submitting this form for accounts maintained outside of the United States by certain foreign financial institutions. Therefore, if you are only submitting this form for an account you hold in the United States, you may leave this field blank. Consult with the person requesting this form if you are uncertain if the financial institution is subject to these requirements.

- A—An organization exempt from tax under section 501(a) or any individual retirement plan as defined in section 7701(a)(37)
- B—The United States or any of its agencies or instrumentalities
- C—A state, the District of Columbia, a possession of the United States, or any of their political subdivisions or instrumentalities
- D—A corporation the stock of which is regularly traded on one or more established securities markets, as described in Reg. section 1.1472-1(c)(1)(i)
- E—A corporation that is a member of the same expanded affiliated group as a corporation described in Reg. section 1.1472-1(c)(1)(i)
- F—A dealer in securities, commodities, or derivative financial instruments (including notional principal contracts, futures, forwards, and options) that is registered as such under the laws of the United States or any state

G—A real estate investment trust

H—A regulated investment company as defined in section 851 or an entity registered at all times during the tax year under the Investment Company Act of 1940

I—A common trust fund as defined in section 584(a)

J—A bank as defined in section 581

K—A broker

L—A trust exempt from tax under section 664 or described in section 4947(a)(1)

M—A tax exempt trust under a section 403(b) plan or section 457(g) plan

**Part I. Taxpayer Identification Number (TIN)**

**Enter your TIN in the appropriate box.** If you are a resident alien and you do not have and are not eligible to get an SSN, your TIN is your IRS individual taxpayer identification number (ITIN). Enter it in the social security number box. If you do not have an ITIN, see *How to get a TIN* below.

If you are a sole proprietor and you have an EIN, you may enter either your SSN or EIN. However, the IRS prefers that you use your SSN.

If you are a single-member LLC that is disregarded as an entity separate from its owner (see *Limited Liability Company (LLC)* on page 2), enter the owner's SSN or EIN, if the owner has one). Do not enter the disregarded entity's EIN. If the LLC is classified as a corporation or partnership, enter the entity's EIN.

**Note.** See the chart on page 4 for further clarification of name and TIN combinations.

**How to get a TIN.** If you do not have a TIN, apply for one immediately. To apply for an SSN, get Form SS-5, Application for a Social Security Card, from your local Social Security Administration office or get this form online at [www.ssa.gov](http://www.ssa.gov). You may also get this form by calling 1-800-772-1213. Use Form W-7, Application for IRS Individual Taxpayer Identification Number, to apply for an ITIN, or Form SS-4, Application for Employer Identification Number, to apply for an EIN. You can apply for an EIN online by accessing the IRS website at [www.irs.gov/businesses](http://www.irs.gov/businesses) and clicking on Employer Identification Number (EIN) under Starting a Business. You can get Forms W-7 and SS-4 from the IRS by visiting [IRS.gov](http://IRS.gov) or by calling 1-800-TAX-FORM (1-800-829-3676).

If you are asked to complete Form W-9 but do not have a TIN, apply for a TIN and write "Applied For" in the space for the TIN, sign and date the form, and give it to the requester. For interest and dividend payments, and certain payments made with respect to readily tradable instruments, generally you will have 60 days to get a TIN and give it to the requester before you are subject to backup withholding on payments. The 60-day rule does not apply to other types of payments. You will be subject to backup withholding on all such payments until you provide your TIN to the requester.

**Note.** Entering "Applied For" means that you have already applied for a TIN or that you intend to apply for one soon.

**Caution:** A disregarded U.S. entity that has a foreign owner must use the appropriate Form W-8.

**Part II. Certification**

To establish to the withholding agent that you are a U.S. person, or resident alien, sign Form W-9. You may be requested to sign by the withholding agent even if items 1, 4, or 5 below indicate otherwise.

For a joint account, only the person whose TIN is shown in Part I should sign (when required). In the case of a disregarded entity, the person identified on the "Name" line must sign. Exempt payees, see *Exempt payee code* earlier.

**Signature requirements.** Complete the certification as indicated in items 1 through 5 below.

1. **Interest, dividend, and barter exchange accounts opened before 1984 and broker accounts considered active during 1983.** You must give your correct TIN, but you do not have to sign the certification.
2. **Interest, dividend, broker, and barter exchange accounts opened after 1983 and broker accounts considered inactive during 1983.** You must sign the certification or backup withholding will apply. If you are subject to backup withholding and you are merely providing your correct TIN to the requester, you must cross out item 2 in the certification before signing the form.
3. **Real estate transactions.** You must sign the certification. You may cross out item 2 of the certification.
4. **Other payments.** You must give your correct TIN, but you do not have to sign the certification unless you have been notified that you have previously given an incorrect TIN. "Other payments" include payments made in the course of the requester's trade or business for rents, royalties, goods (other than bills for merchandise), medical and health care services (including payments to corporations), payments to a nonemployee for services, payments made in settlement of payment card and third party network transactions, payments to certain fishing boat crew members and fishermen, and gross proceeds paid to attorneys (including payments to corporations).
5. **Mortgage interest paid by you, acquisition or abandonment of secured property, cancellation of debt, qualified tuition program payments (under section 529), IRA, Coverdell ESA, Archer MSA or HSA contributions or distributions, and pension distributions.** You must give your correct TIN, but you do not have to sign the certification.

**What Name and Number To Give the Requester**

For this type of account:	Give name and SSN of:
1. Individual	The individual
2. Two or more individuals (joint account)	The actual owner of the account or, if combined funds, the first individual on the account <sup>1</sup>
3. Custodian account of a minor (Uniform Gift to Minors Act)	The minor <sup>2</sup>
4. a. The usual revocable savings trust (grantor is also trustee)	The grantor-trustee <sup>3</sup>
b. So-called trust account that is not a legal or valid trust under state law	The actual owner <sup>1</sup>
5. Sole proprietorship or disregarded entity owned by an individual	The owner <sup>3</sup>
6. Grantor trust filing under Optional Form 1099 Filing Method 1 (see Regulation section 1.671-4(b)(2)(i)(A))	The grantor*
For this type of account:	Give name and EIN of:
7. Disregarded entity not owned by an individual	The owner
8. A valid trust, estate, or pension trust	Legal entity <sup>4</sup>
9. Corporation or LLC electing corporate status on Form 8832 or Form 2553	The corporation
10. Association, club, religious, charitable, educational, or other tax-exempt organization	The organization
11. Partnership or multi-member LLC	The partnership
12. A broker or registered nominee	The broker or nominee
13. Account with the Department of Agriculture in the name of a public entity (such as a state or local government, school district, or prison) that receives agricultural program payments	The public entity
14. Grantor trust filing under the Form 1041 Filing Method or the Optional Form 1099 Filing Method 2 (see Regulation section 1.671-4(b)(2)(i)(B))	The trust

<sup>1</sup> List first and circle the name of the person whose number you furnish. If only one person on a joint account has an SSN, that person's number must be furnished.

<sup>2</sup> Circle the minor's name and furnish the minor's SSN.

<sup>3</sup> You must show your individual name and you may also enter your business or "DBA" name on the "Business name/disregarded entity" name line. You may use either your SSN or EIN (if you have one), but the IRS encourages you to use your SSN.

<sup>4</sup> List first and circle the name of the trust, estate, or pension trust. (Do not furnish the TIN of the personal representative or trustee unless the legal entity itself is not designated in the account title.) Also see *Special rules for partnerships* on page 1.

\*Note. Grantor also must provide a Form W-9 to trustee of trust.

**Note.** If no name is circled when more than one name is listed, the number will be considered to be that of the first name listed.

**Secure Your Tax Records from Identity Theft**

Identity theft occurs when someone uses your personal information such as your name, social security number (SSN), or other identifying information, without your permission, to commit fraud or other crimes. An identity thief may use your SSN to get a job or may file a tax return using your SSN to receive a refund.

To reduce your risk:

- Protect your SSN,
- Ensure your employer is protecting your SSN, and
- Be careful when choosing a tax preparer.

If your tax records are affected by identity theft and you receive a notice from the IRS, respond right away to the name and phone number printed on the IRS notice or letter.

If your tax records are not currently affected by identity theft but you think you are at risk due to a lost or stolen purse or wallet, questionable credit card activity or credit report, contact the IRS Identity Theft Hotline at 1-800-908-4490 or submit Form 14039.

For more information, see Publication 4535, Identity Theft Prevention and Victim Assistance.

Victims of identity theft who are experiencing economic harm or a system problem, or are seeking help in resolving tax problems that have not been resolved through normal channels, may be eligible for Taxpayer Advocate Service (TAS) assistance. You can reach TAS by calling the TAS toll-free case intake line at 1-877-777-4778 or TTY/TDD 1-800-829-4059.

**Protect yourself from suspicious emails or phishing schemes.** Phishing is the creation and use of email and websites designed to mimic legitimate business emails and websites. The most common act is sending an email to a user falsely claiming to be an established legitimate enterprise in an attempt to scam the user into surrendering private information that will be used for identity theft.

The IRS does not initiate contacts with taxpayers via emails. Also, the IRS does not request personal detailed information through email or ask taxpayers for the PIN numbers, passwords, or similar secret access information for their credit card, bank, or other financial accounts.

If you receive an unsolicited email claiming to be from the IRS, forward this message to [phishing@irs.gov](mailto:phishing@irs.gov). You may also report misuse of the IRS name, logo, or other IRS property to the Treasury Inspector General for Tax Administration at 1-800-366-4484. You can forward suspicious emails to the Federal Trade Commission at: [spam@uce.gov](mailto:spam@uce.gov) or contact them at [www.ftc.gov/idtheft](http://www.ftc.gov/idtheft) or 1-877-IDTHEFT (1-877-438-4338).

Visit [IRS.gov](http://IRS.gov) to learn more about identity theft and how to reduce your risk.

**Privacy Act Notice**

Section 6109 of the Internal Revenue Code requires you to provide your correct TIN to persons (including federal agencies) who are required to file information returns with the IRS to report interest, dividends, or certain other income paid to you; mortgage interest you paid; the acquisition or abandonment of secured property; the cancellation of debt; or contributions you made to an IRA, Archer MSA, or HSA. The person collecting this form uses the information on the form to file information returns with the IRS, reporting the above information. Routine uses of this information include giving it to the Department of Justice for civil and criminal litigation and to cities, states, the District of Columbia, and U.S. commonwealths and possessions for use in administering their laws. The information also may be disclosed to other countries under a treaty, to federal and state agencies to enforce civil and criminal laws, or to federal law enforcement and intelligence agencies to combat terrorism. You must provide your TIN whether or not you are required to file a tax return. Under section 3406, payers must generally withhold a percentage of taxable interest, dividend, and certain other payments to a payee who does not give a TIN to the payer. Certain penalties may also apply for providing false or fraudulent information.



---

**From:** [REDACTED]  
**Sent:** Thursday, May 29, 2014 9:27 PM  
**To:** [REDACTED]  
**Subject:** Re: NISSAN EST WORK SHEET.xls  
**Attachments:** [REDACTED].xlsx

----- Forwarded message -----

**From:** [REDACTED]  
**Date:** Thursday, May 29, 2014  
**Subject:** NISSAN EST WORK SHEET.xls  
**To:** [REDACTED]

Here is the revised est.

Hope that helps.

[REDACTED]

---

**From:** [REDACTED]  
**Sent:** Wednesday, May 28, 2014 1:17 PM  
**To:** [REDACTED]  
**Subject:** Re: NISSAN EST WORK SHEET.xls

Thanks [REDACTED]

Is there a chance of breaking down the estimate by parts and labor? I'm not sure Bosch will accept this as it's quite vague.

[REDACTED]

On Wed, May 28, 2014 at 12:02 PM, [REDACTED] te:

Hello,

Here is an est. to have the charge port replaced.

Sincerely,

[REDACTED]

[REDACTED]



Invoice No.



**ESTIMATE**

**Customer**

Name

Address \_\_\_\_\_

City \_\_\_\_\_ State \_\_\_\_\_ ZIP \_\_\_\_\_

Phone \_\_\_\_\_

**Misc**

Date 5.28.14

Order No. \_\_\_\_\_

Rep JOHN

VIN DC401959

Qty	Description	Unit Price	TOTAL
1	110/220 CHARGE PORT PART	\$ 872.00	\$ 872.00
4	LABOR	\$ 132.00	\$ 528.00
	HAZ FEE	\$ 19.26	\$ -
		SubTotal	\$ 1,400.00
		Shipping	
		TOTAL	\$ 1,533.00

**Payment** Select One...

Comments

Name \_\_\_\_\_

CC # \_\_\_\_\_

Expires \_\_\_\_\_

Tax Rate(s)

9.50%	\$ 133.00
<b>TOTAL</b>	<b>\$ 1,533.00</b>

Office Use Only

\_\_\_\_\_



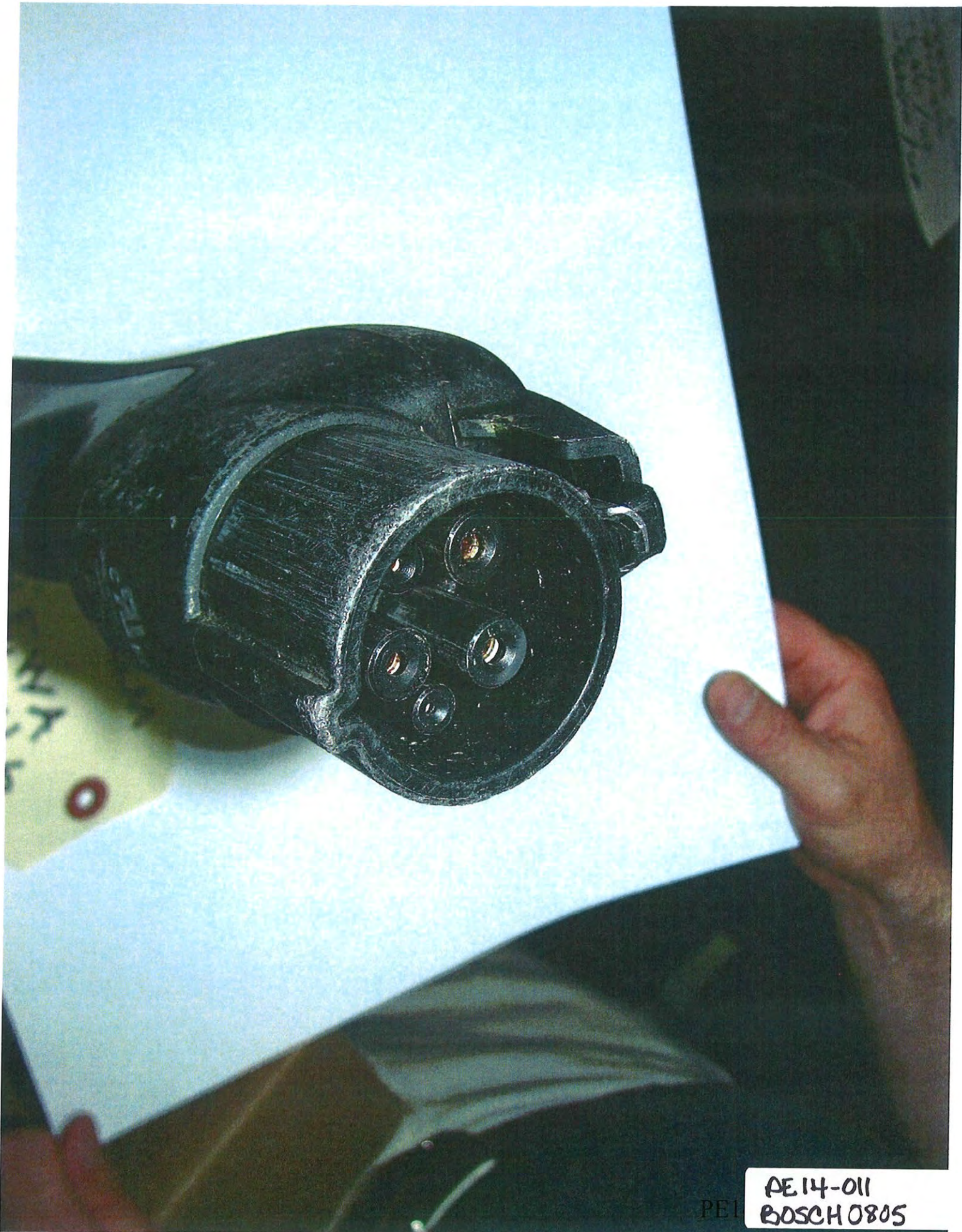

AE14-011  
BOSCH 0805

PEI

STUCK + WARM  
COUPLER  
SEATTLE, WA  
5/20/14



STUCK + WARM  
COUPLER  
SEATTLE, WA  
5/20/14 #6

P PE14-011  
BOSCH 0807

STUCK + WARM  
COUPLER  
SEATTLE, WA  
5/20/14 #6



STUCK + WARM  
COUPLER  
SEATTLE, WA  
5/20/14 #6



INM  
ATTLE, WA  
/14 #6



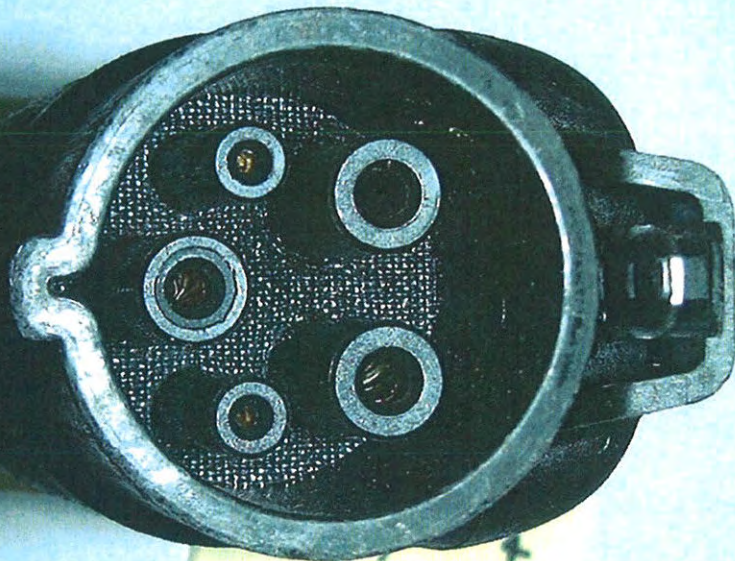

9#  
WA  
WARM

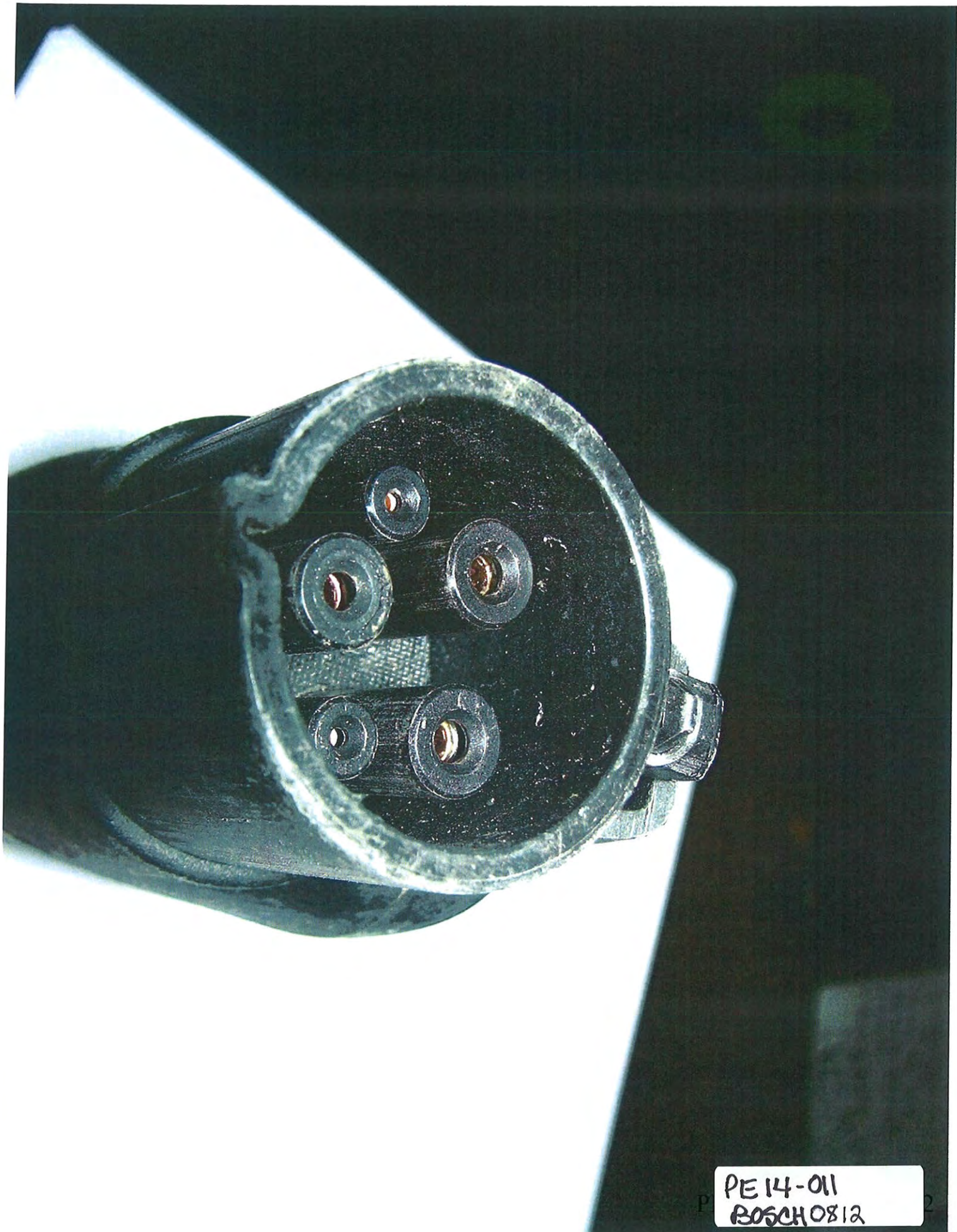

PE 14-011  
BOSCH 0812

TAB 7A

---

**From:** [REDACTED]  
**Sent:** Friday, April 11, 2014 9:09 AM  
**To:** [REDACTED]  
**Subject:** RE: Warranty Replacement - PX Cord

Sorry,

Let me clear that up. The charger started sticking and it didn't seem to be clicking in the button on the top seemed soft so I contact you. The pictures I sent on 3/31 were when the problem first started. On Tuesday 4/11/14 the charger fused to the car in the overnight charge. Then we called roadside and sent an email to you because we couldn't wait any longer.

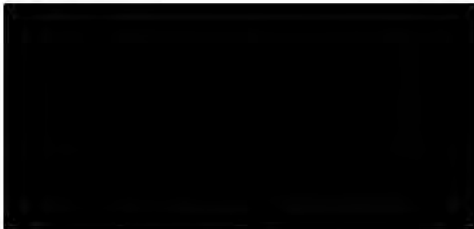

Visit our website at

This message is intended only for use by the named addressee and may contain privileged and/or confidential information. If you are not the named addressee, you should not disseminate, copy, or take any action in reliance on it. If you have received this message in error, please immediately notify the sender and delete this message and any attachment. Thank you.

---

**From:** [REDACTED]  
**Sent:** Friday, April 11, 2014 8:59 AM  
**To:** [REDACTED]  
**Subject:** RE: Warranty Replacement - PX Cord



Thank you for the information. It's fine that you continued to use the charger. We were just trying to determine what happened and how it broke and fused together because the notes in the ticket with technical support only stated that the handle was not locking or unlocking properly and the pictures you submitted showed it detached from the vehicle with nothing broken off. I assumed the other issues happened after speaking with technical support and I will add this information to the ticket.

Thank you,



Bosch Automotive Aftermarket  
Automotive Service Solutions  
EVSE Project Coordinator (AA-AS)



[REDACTED]

The information contained in this electronic mail transmission is intended by Robert Bosch GmbH for the use of the named individual or entity to which it is directed and may contain information that is confidential or privileged. If you have received this electronic mail transmission in error, please delete it from your system without copying or forwarding it, and notify the sender of the error by reply email so that the sender's address records can be corrected.

---

**From:** [REDACTED]  
**Sent:** Friday, April 11, 2014 8:40 AM  
**To:** [REDACTED]  
**Subject:** RE: Warranty Replacement - PX Cord

Hi [REDACTED]

The handle of the charging unit broke so part of it remained in the car. Mr Electric took what we could get free and the dealership has what we couldn't. If you saw a picture of the car without the charger piece attached then it was after the dealership removed it. But last I heard from them it was fused together and couldn't be removed. I did continue to use the charger but the reason I called for service was it started to stick.

I would hope that if there was any concern on you part about using the unit that it would be communicated. I was never told not to use the unit or that it could damage the unit or my car. I thought since there didn't seem to be a rush to replace the unit that there was no danger of further damage happening. I depend on this car. My only other option was to not use my car. I don't have another car waiting to take me to work when my Leaf can't. No one ever communicated that I should be concerned about using the unit. In fact I sent pictures of the unit to AA-AS service solutions on 3/31/14 and my appointment with Mr. Electric to replace my unit wasn't until 4/18. I would think if I shouldn't be using my charger that the response time would be much better.

Hope this helps,

[REDACTED]

[REDACTED]

Visit our website at  
<http://www.magnaelectronics.com>

This message is intended only for use by the named addressee and may contain privileged and/or confidential information. If you are not the named addressee, you should not disseminate, copy, or take any action in reliance on it. If you have received this message in error, please immediately notify the sender and delete this message and any attachment. Thank you.

---

**From:** [REDACTED]  
**Sent:** Friday, April 11, 2014 7:44 AM  
**To:** [REDACTED]  
**Subject:** RE: Warranty Replacement - PX Cord

Hi again [REDACTED]

I viewed the pictures that were sent to technical support and noticed the handle was not stuck to the vehicle. Did you continue to use the charger after calling into technical support and that's when it got stuck and had to be taken to the dealership?

We are just trying to gather some information to figure out what happened.

[REDACTED]

[REDACTED]

Bosch Automotive Aftermarket  
Automotive Service Solutions  
EVSE Project Coordinator (AA-AS)

[REDACTED]

[REDACTED]

The information contained in this electronic mail transmission is intended by Robert Bosch GmbH for the use of the named individual or entity to which it is directed and may contain information that is confidential or privileged. If you have received this electronic mail transmission in error, please delete it from your system without copying or forwarding it, and notify the sender of the error by reply email so that the sender's address records can be corrected.

---

**From:** [REDACTED]  
**Sent:** Friday, April 11, 2014 7:20 AM  
**To:** [REDACTED]  
**Subject:** RE: Warranty Replacement - PX Cord

Hi [REDACTED]

Please see my responses below in red.

Thank you,

[REDACTED]

Bosch Automotive Aftermarket  
Automotive Service Solutions  
EVSE Project Coordinator (AA-AS)

[REDACTED]

[REDACTED]

The information contained in this electronic mail transmission is intended by Robert Bosch GmbH for the use of the named individual or entity to which it is directed and may contain information that is confidential or privileged. If you have received this electronic mail transmission in error, please delete it from your system without copying or forwarding it, and notify the sender of the error by reply email so that the sender's address records can be corrected.

---

**From:** [REDACTED]  
**Sent:** Thursday, April 10, 2014 3:34 PM  
**To:** [REDACTED]  
**Subject:** RE: Warranty Replacement - PX Cord

[REDACTED]

I just called LaFontaine service they say the two parts won't separate. They are "fused" together. If they are unable to get us the part that will have to suffice. Thank you for contacting them.

Is there a problem with this style unit. Have you had problems with this charger? Do you have another style with a better track record?  
All of the Bosch chargers have a low volume of warranty claims. The Power Xpress is the most durable and only moveable Bosch charger we sell.

Can you give me another style?  
Chargers under warranty are replaced with the same style charger, not different chargers. If you are interested in a different charger and want me to speak with a manager to see if he will approve a different replacement, I'd be more than happy. However, I cannot guarantee anything.

Did the replacement get to Mr. Electric?  
Mr. Electric of Macomb has received the charger and will be reaching out to you soon, if they haven't already.

Sorry,

[REDACTED]

[REDACTED]

This message is intended only for use by the named addressee and may contain privileged and/or confidential information. If you are not the named addressee, you should not disseminate, copy, or take any action in reliance on it. If you have received this message in error, please immediately notify the sender and delete this message and any attachment. Thank you.

---

**Sent:** Thursday, April 10, 2014 3:16 PM  
**To:** [REDACTED]  
**Subject:** RE: Warranty Replacement - PX Cord

[Redacted]

We may need the part back that broke off inside the vehicle – if Nissan is able to get it out. I will let you know for sure if we need it once I have confirmation.

[Redacted]

Bosch Automotive Aftermarket  
Automotive Service Solutions  
EVSE Project Coordinator (AA-AS)

[Redacted]

[Redacted]

The information contained in this electronic mail transmission is intended by Robert Bosch GmbH for the use of the named individual or entity to which it is directed and may contain information that is confidential or privileged. If you have received this electronic mail transmission in error, please delete it from your system without copying or forwarding it, and notify the sender of the error by reply email so that the sender's address records can be corrected.

---

F [Redacted]

**Sent:** Tuesday, April 08, 2014 9:48 AM

**To:** [Redacted]

**Subject:** RE: warranty replacement - PX Cord

No, don't worry about it. You can scrap it. Thanks for asking though.

[Redacted]

[Redacted]

Bosch Automotive Aftermarket  
Automotive Service Solutions  
EVSE Project Coordinator (AA-AS)

[Redacted]

[Redacted]

The information contained in this electronic mail transmission is intended by Robert Bosch GmbH for the use of the named individual or entity to which it is directed and may contain information that is confidential or privileged. If you have received this electronic mail transmission in error, please delete it from your system without copying or forwarding it, and notify the sender of the error by reply email so that the sender's address records can be corrected.

---

**From:** [REDACTED]  
**Sent:** Tuesday, April 08, 2014 8:57 AM  
**To:** [REDACTED]  
**Subject:** RE: warranty replacement - PX Cord

I can get the part from the dealership once they remove. Do you need it?



This message is intended only for use by the named addressee and may contain privileged and/or confidential information. If you are not the named addressee, you should not disseminate, copy, or take any action in reliance on it. If you have received this message in error, please immediately notify the sender and delete this message and any attachment. Thank you.

---

**Sent:** Tuesday, April 08, 2014 8:55 AM  
**To:** [REDACTED]  
**Subject:** RE: Warranty Replacement - PX Cord

I will forward this information onto the electrician. Thanks!



Bosch Automotive Aftermarket  
Automotive Service Solutions  
EVSE Project Coordinator (AA-AS)



The information contained in this electronic mail transmission is intended by Robert Bosch GmbH for the use of the named individual or entity to which it is directed and may contain information that is confidential or privileged. If you have received this electronic mail transmission in error, please delete it.

from your system without copying or forwarding it, and notify the sender of the error by reply email so that the sender's address records can be corrected.

---

**From:** [REDACTED]  
**Sent:** Tuesday, April 08, 2014 8:52 AM  
**To:** [REDACTED]  
**Subject:** RE: Warranty Replacement - PX Cord

Just wanted to let you know that Nissan roadside is coming out to remove the part that is stuck in my car or my warranty is void. So the charging unit will need to be cut to free the car.

[REDACTED]

This message is intended only for use by the named addressee and may contain privileged and/or confidential information. If you are not the named addressee, you should not disseminate, copy, or take any action in reliance on it. If you have received this message in error, please immediately notify the sender and delete this message and any attachment. Thank you.

---

**Sent:** Tuesday, April 08, 2014 8:44 AM  
**Subject:** RE: Warranty Replacement - PX Cord

Never mind. I spoke with your husband just now and he spoke to Mr. Electric. All set!

Have a great day! ☺

T  
A  
[REDACTED]

Bosch Automotive Aftermarket  
Automotive Service Solutions  
EVSE Project Coordinator (AA-AS)

The information contained in this electronic mail transmission is intended by Robert Bosch GmbH for the use of the named individual or entity to which it is directed and may contain information that is confidential or privileged. If you have received this electronic mail transmission in error, please delete it from your system without copying or forwarding it, and notify the sender of the error by reply email so that the sender's address records can be corrected.

---

**From:** [REDACTED]  
**Sent:** Tuesday, April 08, 2014 8:42 AM  
**To:** [REDACTED]  
**Subject:** RE: Warranty Replacement - PX Cord

The electrician is heading out there right now. John said he tried to call you, but didn't get an answer. Are you going to be at your residence this morning?

Thank you,

[REDACTED]

Bosch Automotive Aftermarket  
Automotive Service Solutions  
EVSE Project Coordinator (AA-AS)

The information contained in this electronic mail transmission is intended by Robert Bosch GmbH for the use of the named individual or entity to which it is directed and may contain information that is confidential or privileged. If you have received this electronic mail transmission in error, please delete it from your system without copying or forwarding it, and notify the sender of the error by reply email so that the sender's address records can be corrected.

---

**From:** [REDACTED]  
**Sent:** Tuesday, April 08, 2014 8:38 AM  
**To:** [REDACTED]  
**Subject:** RE: Warranty Replacement - PX Cord

Thanks you have been so helpful!

[REDACTED]

Magna Electronics Technology Inc.  
10410 North Holly Rd, Holly, MI 48442 USA

[REDACTED]

Visit our website at [REDACTED]

This message is intended only for use by the named addressee and may contain privileged and/or confidential information. If you are not the named addressee, you should not disseminate, copy, or take any action in reliance on it. If you have received this message in error, please immediately notify the sender and delete this message and any attachment. Thank you.

[Redacted]

**Sent:** Tuesday, April 08, 2014 8:30 AM  
**To:** [Redacted]  
**Subject:** RE: Warranty Replacement - PX Cord

I just spoke with [Redacted]'s going to make some calls and let me know. You may hear from him before me. ☺

Thank you  
[Redacted]

Bosch Automotive Aftermarket  
Automotive Service Solutions  
EVSE Project Coordinator (AA-AS)

[Redacted]

The information contained in this electronic mail transmission is intended by Robert Bosch GmbH for the use of the named individual or entity to which it is directed and may contain information that is confidential or privileged. If you have received this electronic mail transmission in error, please delete it from your system without copying or forwarding it, and notify the sender of the error by reply email so that the sender's address records can be corrected.

---

**From:** [Redacted]  
**Sent:** Tuesday, April 08, 2014 8:26 AM  
**To:** [Redacted]  
**Subject:** RE: Warranty Replacement - PX Cord

Thanks I don't think they are in yet. I'll try at 9.

[Redacted]

This message is intended only for use by the named addressee and may contain privileged and/or confidential information. If you are not the named addressee, you should not disseminate, copy, or take any action in reliance on it. If you have received this message in error, please immediately notify the sender and delete this message and any attachment. Thank you.

[REDACTED]  
**Sent:** Tuesday, April 08, 2014 8:24 AM

**To:** [REDACTED]  
**Subject:** RE: Warranty Replacement - PX Cord

[REDACTED]

I will contact them and see if they can get out there today. If you would like to contact them as well, there contact information is below:

Phone [REDACTED]

Thank you  
[REDACTED]

Bosch Automotive Aftermarket  
Automotive Service Solutions  
EVSE Project Coordinator (AA-AS)

[REDACTED]

The information contained in this electronic mail transmission is intended by Robert Bosch GmbH for the use of the named individual or entity to which it is directed and may contain information that is confidential or privileged. If you have received this electronic mail transmission in error, please delete it from your system without copying or forwarding it, and notify the sender of the error by reply email so that the sender's address records can be corrected.

---

**From:** [REDACTED]  
**Sent:** Tuesday, April 08, 2014 8:19 AM  
**To:** [REDACTED]  
**Subject:** RE: warranty Replacement - PX Cord  
**Importance:** High

[REDACTED]

I have an emergency the plug broke off in my car this morning. Can you get someone out today? I really need the car my husband and I both work.

Thanks,

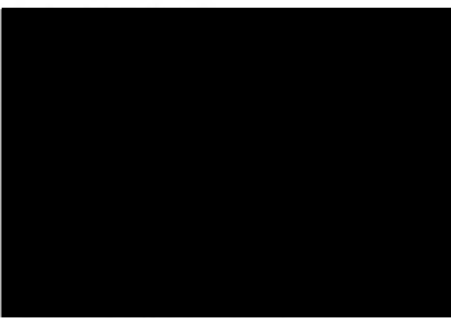

This message is intended only for use by the named addressee and may contain privileged and/or confidential information. If you are not the named addressee, you should not disseminate, copy, or take any action in reliance on it. If you have received this message in error, please immediately notify the sender and delete this message and any attachment. Thank you.



**Sent:** Tuesday, April 01, 2014 11:36 AM

**Subject:** Warranty Replacement - PX Cord



Preston asked that I email Mr. Electric of Macomb's contact information. They will be reaching out to you and Preston to schedule a date to swap out the cord as soon as they receive it. It should arrive in approximately 5 business days.



Thank you,



Bosch Automotive Aftermarket  
Automotive Service Solutions  
EVSE Project Coordinator (AA-AS)

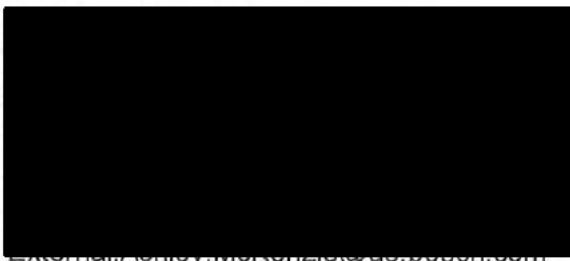

The information contained in this electronic mail transmission is intended by Robert Bosch GmbH for the use of the named individual or entity to which it is directed and may contain information that is confidential or privileged. If you have received this electronic mail transmission in error, please delete it from your system without copying or forwarding it, and notify the sender of the error by reply email so that the sender's address records can be corrected.



---

From:  
Sent:  
To:  
Subject:

[REDACTED]

Tuesday, April 22, 2014 10:12 AM

[REDACTED]



STUCK  
SWAGETE  
4/22/11

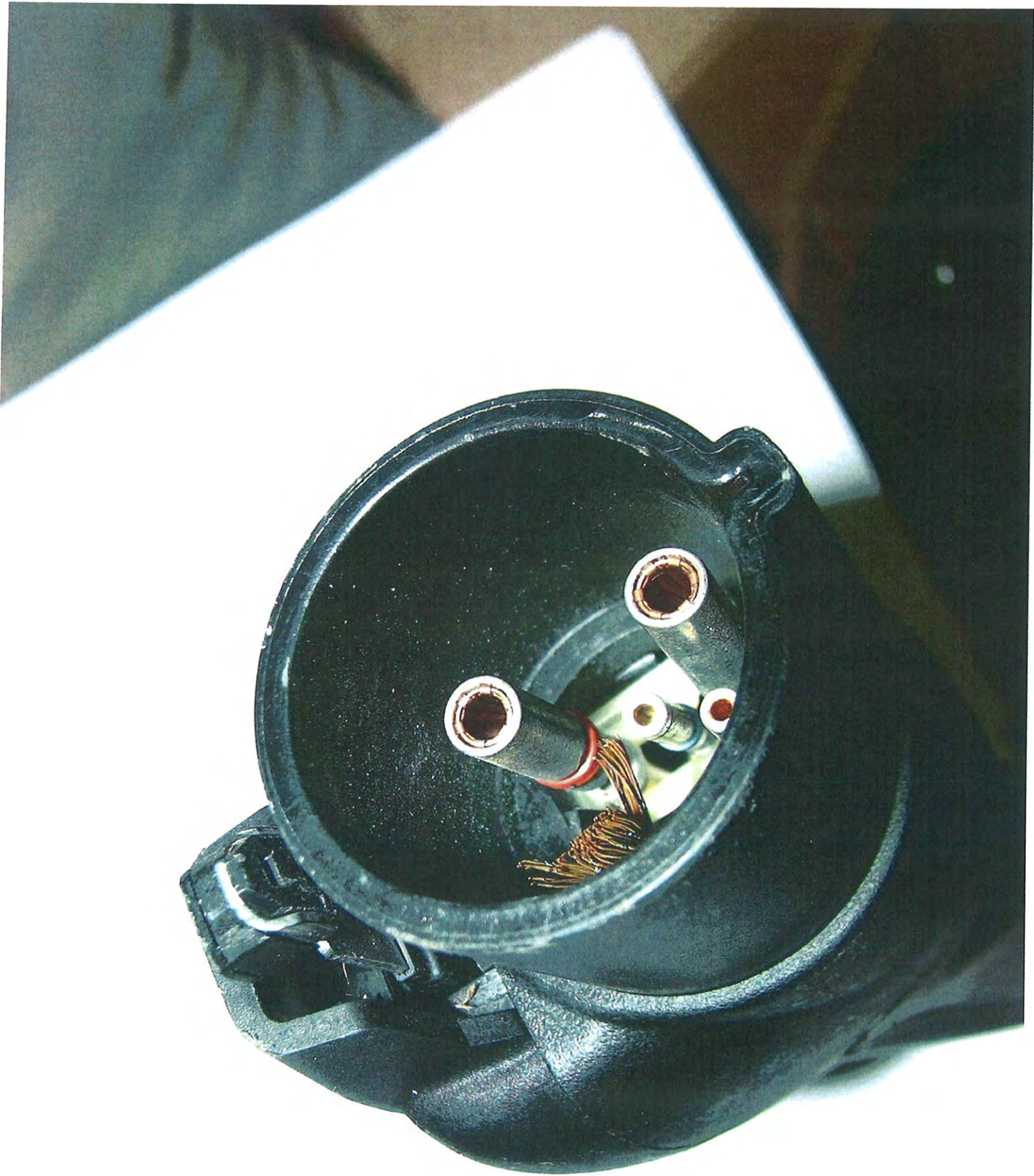

PE14-011BOSCH0849

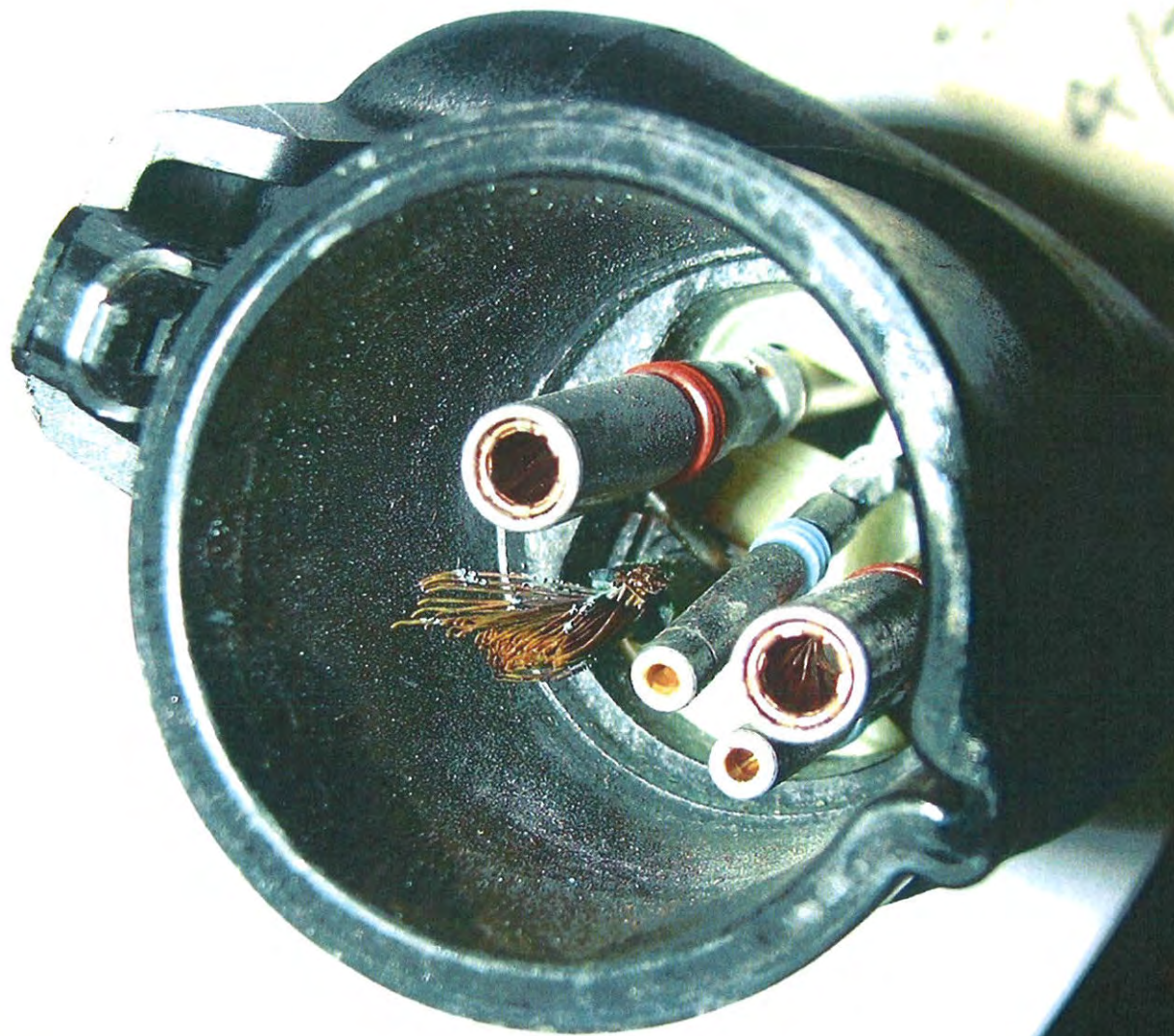

TRUCK  
2004  
9/22/10



Handwritten text on a yellow sticky note, oriented upside down relative to the handle. The text includes a red circle, a hash symbol (#), and the word "CREEK".

PE14-011BOSCH0851

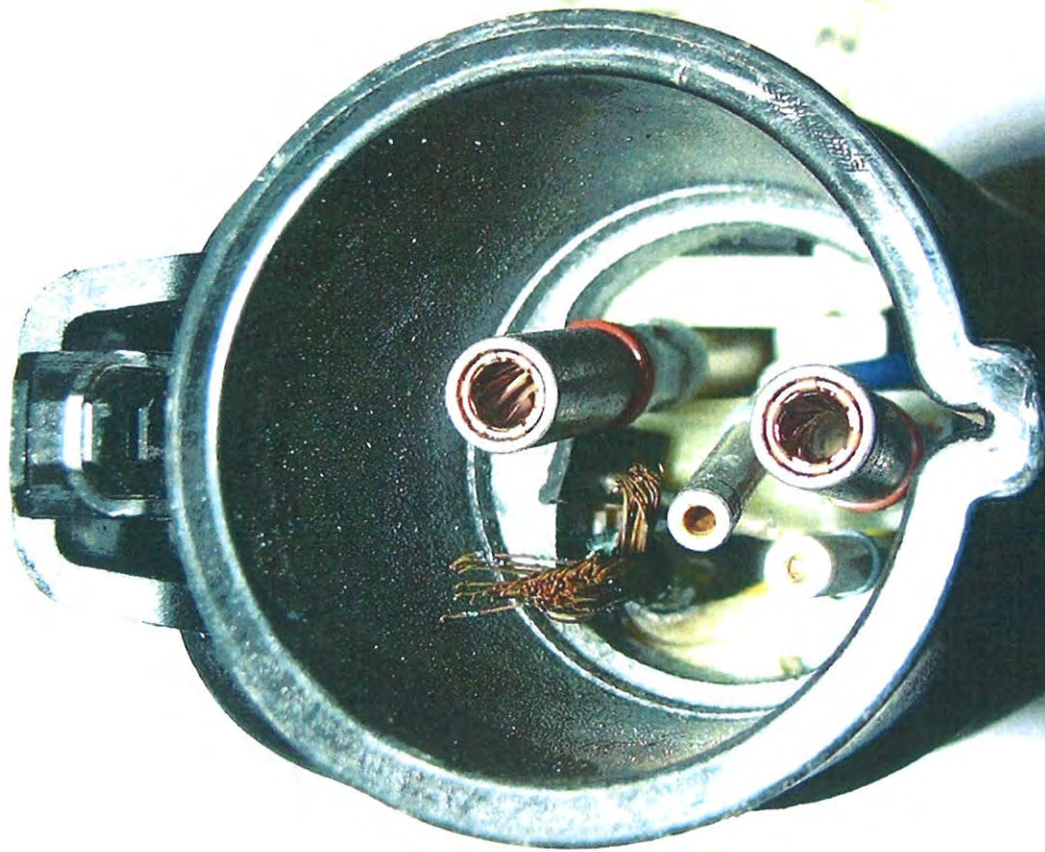

12 Coupler  
1332 REF  
2/1 + #7

P PE14-011  
BOSCH052

STUCK COUPLER  
SWARTZ CREEK  
4/22/14 #7



STUCK COUPLER  
SWARTZ CREEK

4/22/14 #7



PE14-011BOSCH0854

STUCK COUPLER  
SWARTZ CREEK  
4/22/14 # 7



TAB 8A

---

**From:**  
**Sent:**  
**To:**  
**Subject:**

[REDACTED]  
Monday, April 21, 2014 6:04 PM

[REDACTED]  
Nissan Leaf with stuck Power Express Nozzle

[REDACTED]

Can you please contact the following customer about Nissan Leaf with stuck Power Express nozzle.. We have tried many things and can not get it unplugged from the vehicle. We had the owner turn off the breaker. Please contact owner for

[REDACTED]

[REDACTED]

The information contained in this electronic mail transmission is intended by Robert Bosch GmbH for the use of the named individual or entity to which it is directed and may contain information that is confidential or privileged. If you have received this electronic mail transmission in error, please delete it from your system without copying or forwarding it, and notify the sender of the error by reply email so that the sender's address records can be corrected.



---

**From:** [REDACTED]  
**Sent:** Tuesday, April 22, 2014 9:54 AM  
**To:** [REDACTED]  
**Subject:** Power express nissan leaf

[REDACTED]

Per our conversation earlier this morning here is the information you were looking for.

[REDACTED]

[REDACTED]

The information contained in this electronic mail transmission is intended by Robert Bosch GmbH for the use of the named individual or entity to which it is directed and may contain information that is confidential or privileged. If you have received this electronic mail transmission in error, please delete it from your system without copying or forwarding it, and notify the sender of the error by reply email so that the sender's address records can be corrected.



---

**From:** [REDACTED]  
**Sent:** Tuesday, April 22, 2014 11:00 AM  
**To:** [REDACTED]  
**Cc:** [REDACTED]  
**Subject:** You Nissan Leaf / Charging Station issue

[REDACTED]

We have tried to call the phone number below several times this morning....no answer and voice mail for [REDACTED] is full.

Please call my mobile number [REDACTED] regarding your Nissan Leaf / Charging Station issue for further assistance.

[REDACTED]

With Best Regards,

[REDACTED]

Bosch Automotive Aftermarket  
Automotive Service Solutions  
Product Manager - Charging

[REDACTED]

The information contained in this electronic mail transmission is intended by Robert Bosch GmbH for the use of the named individual or entity to which it is directed and may contain information that is confidential or privileged. If you have received this electronic mail transmission in error, please delete it from your system without copying or forwarding it, and notify the sender of the error by reply email so that the sender's address records can be corrected.



---

**From:** [REDACTED]  
**Sent:** Friday, April 25, 2014 3:53 PM  
**To:** [REDACTED]  
**Subject:** Stuck charger in LEAF

H [REDACTED]

Thanks again for coming out to personally look at my charger and for all the knowledge you imparted. I took the LEAF in yesterday and they are ordering a new part which should be there by Monday. The dealer talked to Nissan corporate and they were saying something to the effect that they have seen issues with SPX charging stations and that they have melting issues inside of the charging station nozzle (where we saw that it was damaged.) Take that as you will but I wanted to relay any information that I got from them. Have you guys figured out why the nozzle was so difficult to disengage?

Thanks again, it was a pleasure to meet you

[REDACTED]



---

**From:** [REDACTED]  
**Sent:** Saturday, April 26, 2014 7:59 PM  
**To:** [REDACTED]  
**Subject:** RE: Stuck charge station coupler in LEAF

Hi [REDACTED]

Thank you for the below information, glad to hear your experience has been hassle free.

We have an analysis process to evaluate the suspect connector, including multiple people, our Quality & Engineering, parts suppliers, etc. so it will take some time. Therefore, to answer your question directly, no, we have not figured out why the handle may have gotten stuck, but we're working on it on it. As I mentioned to you the vehicle/inlet/coupler/charge station operate as a system. The best situation would be for us to have the vehicle Inlet back to root cause the fitment issue. I know it may be a lot to ask, especially if the dealer pays for the repair, but can you ask for the vehicle inlet back?

We'll do our best to root cause it without the vehicle inlet, but the most thorough investigation would include the mating inlet.

P.S. I am shipping your charge station back tomorrow, so you should see it on Tuesday.

Best Regards,

[REDACTED]  
Bosch Automotive Aftermarket  
Automotive Service Solutions  
Product Manager



The information contained in this electronic mail transmission is intended by Robert Bosch GmbH for the use of the named individual or entity to which it is directed and may contain information that is confidential or privileged. If you have received this electronic mail transmission in error, please delete it from your system without copying or forwarding it, and notify the sender of the error by reply email so that the sender's address records can be corrected.

---

**From:** [REDACTED]  
**Sent:** Friday, April 25, 2014 3:53 PM  
**To:** [REDACTED]  
**Subject:** Stuck charger in LEAF



---

**From:** [REDACTED]  
**Sent:** Monday, April 28, 2014 10:20 AM  
**To:** [REDACTED]  
**Subject:** Re: Stuck charge station coupler in LEAF

[REDACTED]

This morning I contacted the dealer requesting the inlet. Unfortunately, I was told that due to in being warranty work it would have be sent to Nissan. And since I'm leasing the vehicle I'm not sure how much pressure I can put on them to release the part to me. If you have any suggestions to try, I'd be open to that.

Thanks, [REDACTED]  
On Saturday, April 26, 2014 7:59 PM, [REDACTED] wrote:  
Hi [REDACTED]

Thank you for the below information, glad to hear your experience has been hassle free.

We have an analysis process to evaluate the suspect connector, including multiple people, our Quality & Engineering, parts suppliers, etc. so it will take some time. Therefore, to answer your question directly, no, we have not figured out why the handle may have gotten stuck, but we're working on it on it. As I mentioned to you the vehicle/inlet/coupler/charge station operate as a system. The best situation would be for us to have the vehicle inlet back to root cause the fitment issue. I know it may be a lot to ask, especially if the dealer pays for the repair, but can you ask for the vehicle inlet back?

We'll do our best to root cause it without the vehicle inlet, but the most thorough investigation would include the mating inlet.

P.S. I am shipping your charge station back tomorrow, so you should see it on Tuesday.

Best Regards,

[REDACTED]

Bosch Automotive Aftermarket  
Automotive Service Solutions  
Product Manager

[REDACTED]

The information contained in this electronic mail transmission is intended by Robert Bosch GmbH for the use of the named individual or entity to which it is directed and may contain information that is confidential or privileged. If you have received this electronic mail transmission in error, please delete it from your system without copying or forwarding it, and notify the sender of the error by reply email so that the sender's address records can be corrected.

---

**From:** [REDACTED]

**Sent:** Friday, April 25, 2014 3:53 PM

**To:** [REDACTED]

**Subject:** Stuck charger in LEAF

[REDACTED]

Thanks again for coming out to personally look at my charger and for all the knowledge you imparted. I took the LEAF in yesterday and they are ordering a new part which should be there by Monday. The dealer talked to Nissan corporate and they were saying something to the effect that they have seen issues with SPX charging stations and that they have melting issues inside of the charging station nozzle (where we saw that is was damaged.) Take that as you will but I wanted to relay any information that I got from them. Have you guys figured out why the nozzle was so difficult to disengage?

Thanks again, it was pleasure to meet you

[REDACTED]



STUCK Coupler  
MAYBEE  
ALSO

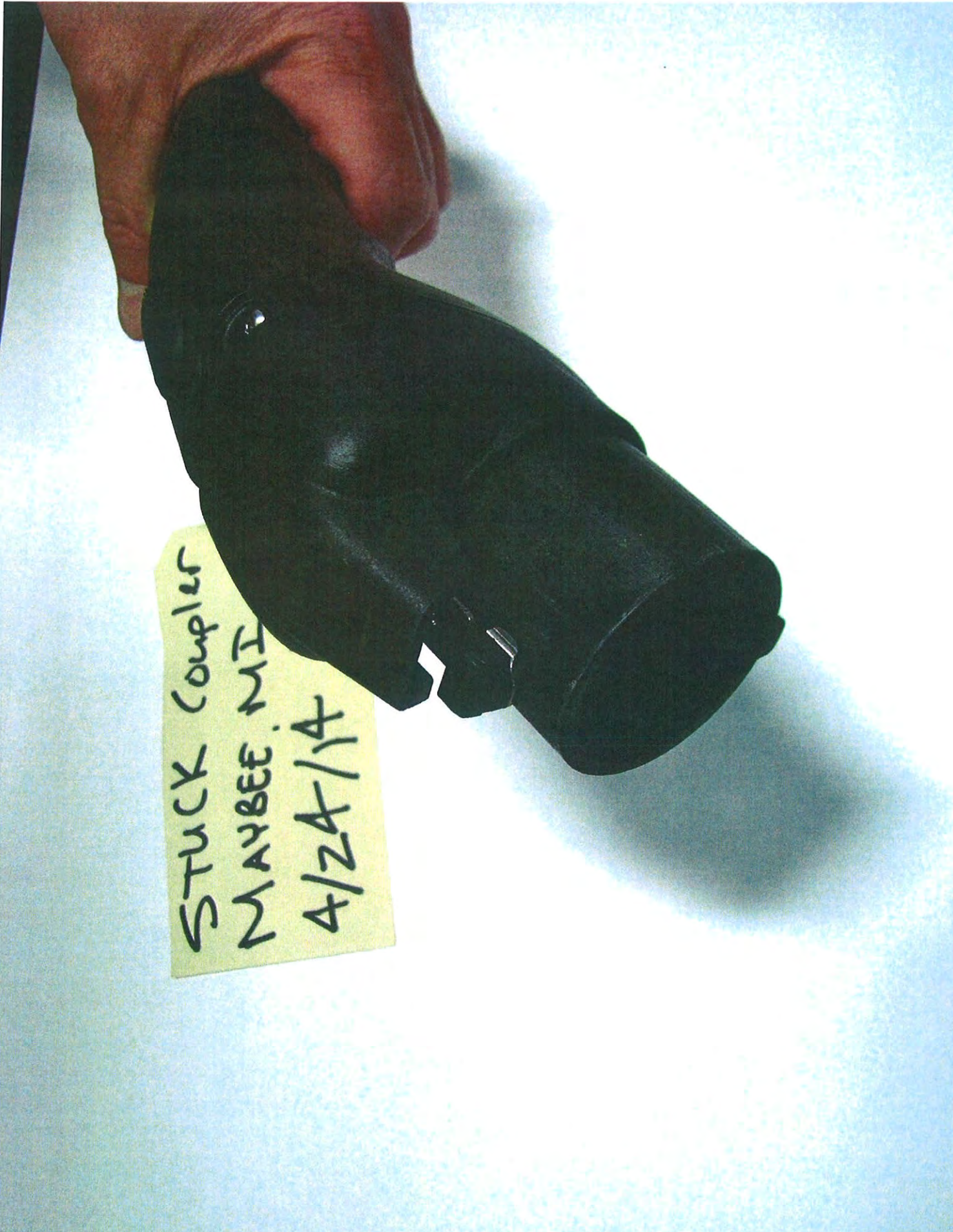

A hand is holding a black, cylindrical power tool handle. A yellow sticky note is attached to the handle with a small metal fastener. The note contains handwritten text. The background is a plain, light-colored surface.

STUCK Coupler  
MAYBE MI  
4/2A/1A

STUCK Coupler  
MAYBEE MI ○  
4/24/14 #8



STUCK Coupler  
MAYBE MI ○  
4/24/14 # 8

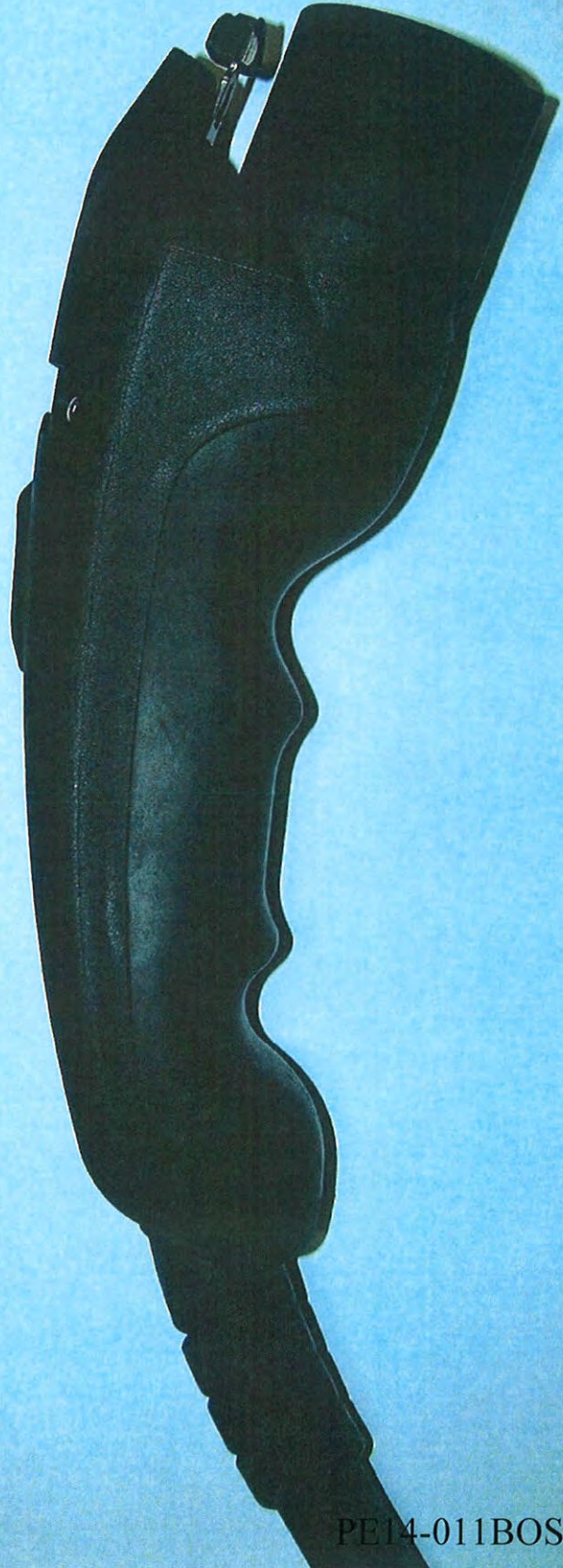

STUCK Coupler  
MAYBEE. MI ○  
4/24/14 #8

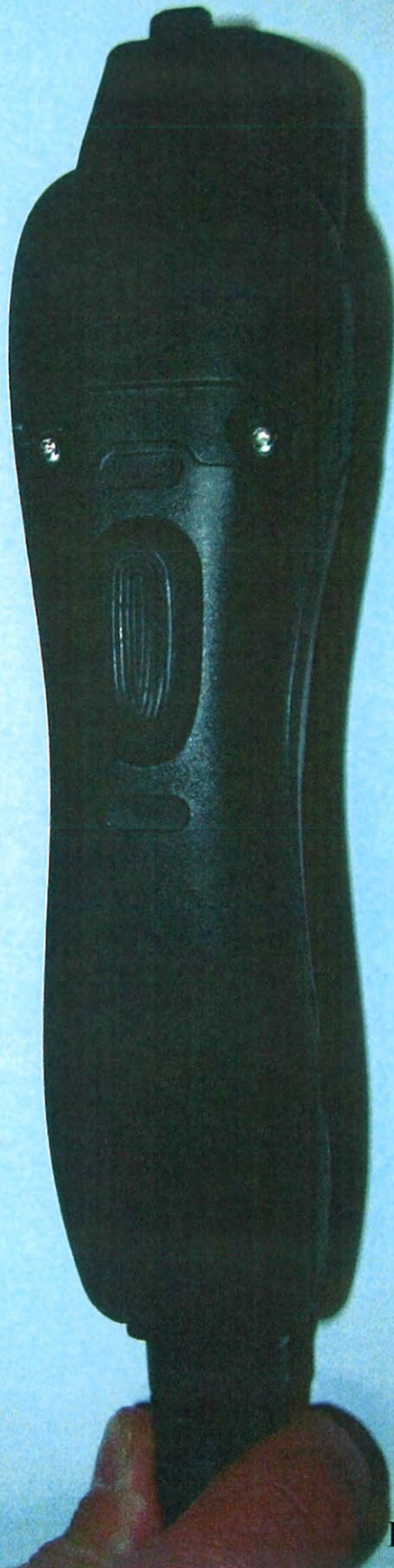

PE14-011BOSCH0878



PE14-011BOSCH0879

K Coupler  
see NH 33  
/14 #8

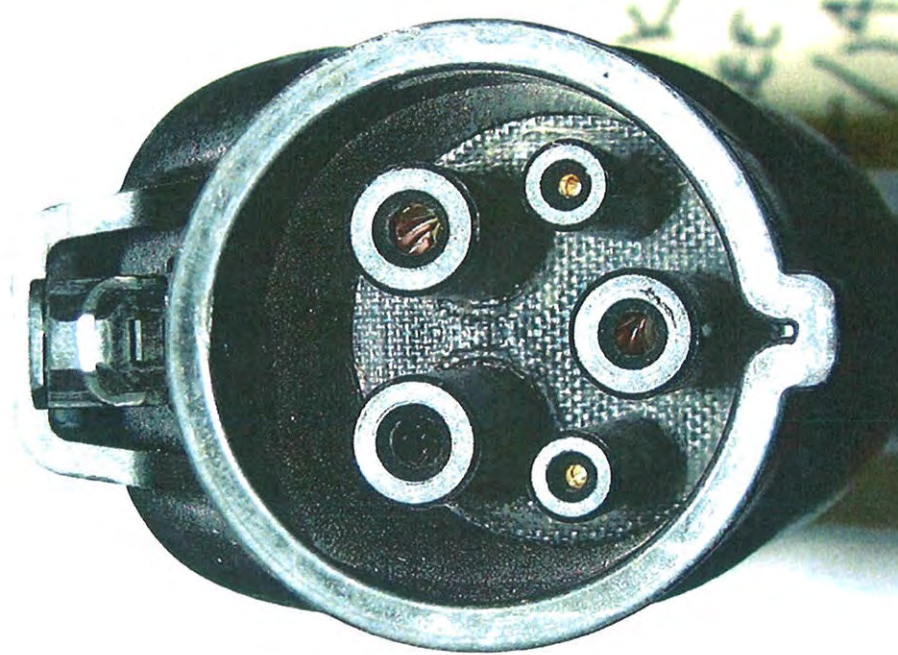

PE14-011  
BOSCH0880

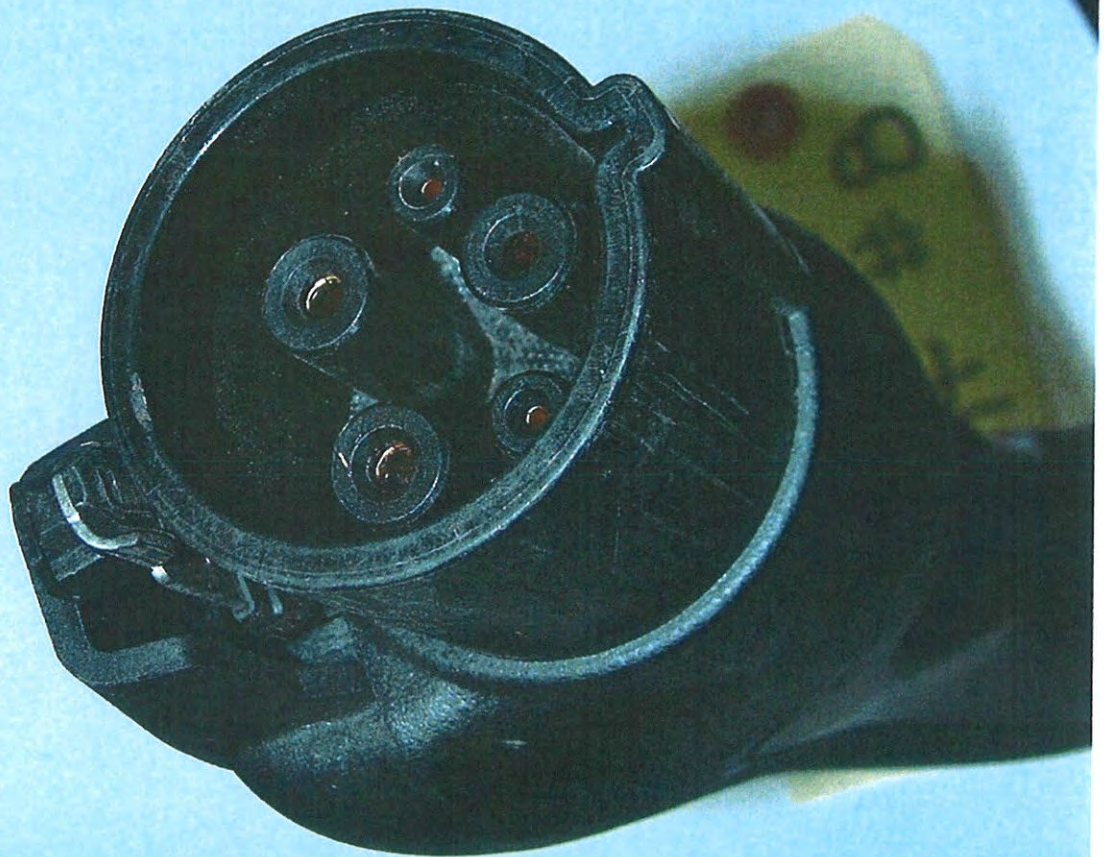

PE14-011BOSCH0881

STUCK  
MAYBEE  
24/14

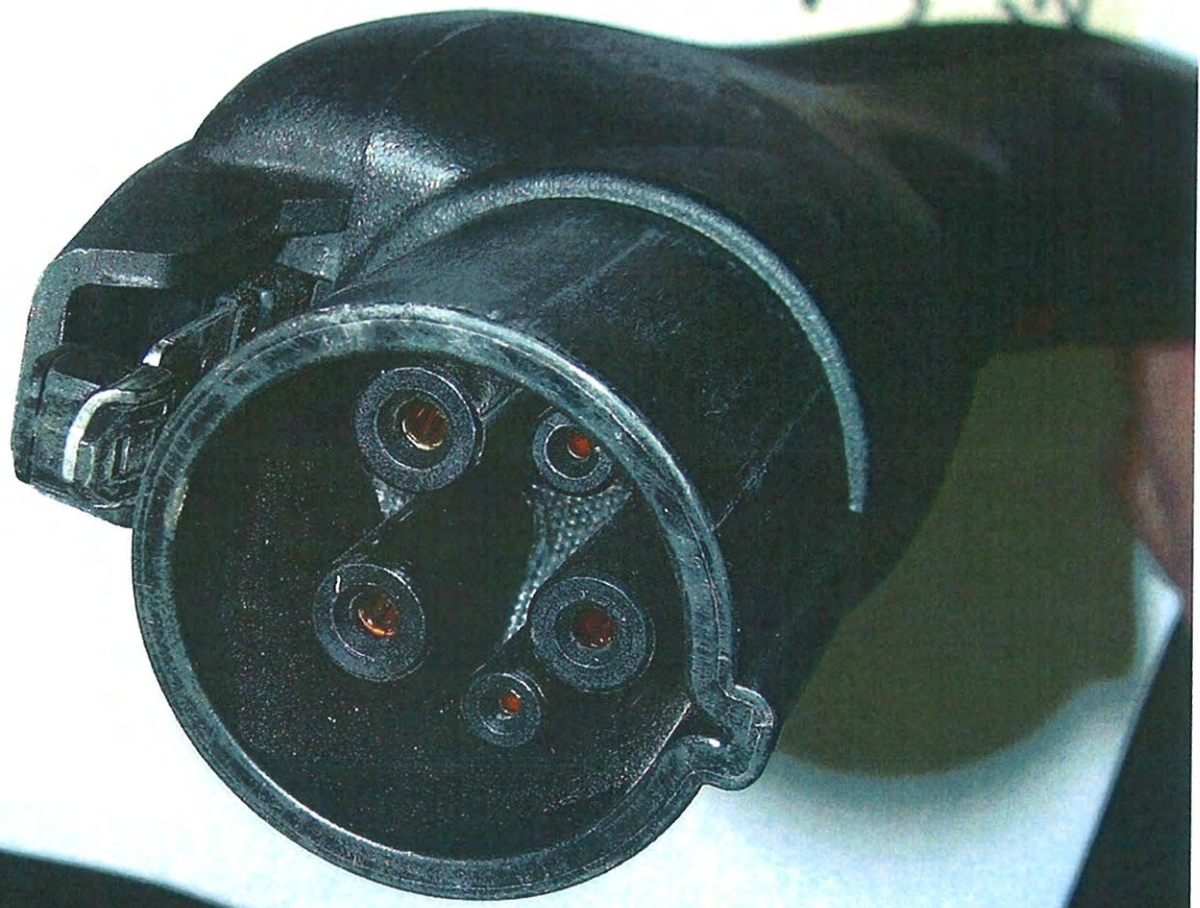

PE 14-011  
BOSCH 0882

STUCK Coupler  
MAYBEE, MI  
4/24-1/4 #8



PEI

PE 14-011  
BOSCH 0883

From:  
Sent:  
To:  
Cc:  
Subject:  
Attachments:

Thursday, April 24, 2014 10:29 AM

[REDACTED]  
[REDACTED]  
Power Xpress coupler stuck on Nissan Leaf resolution  
102\_2691.JPG; 102\_2690.JPG; 102\_2688.JPG; 102\_2687.JPG; 102\_2686.JPG; 102\_2685.JPG; 102\_2683.JPG; 102\_2679.JPG



PE14-011BOSCH0885

The information contained in this electronic mail transmission is intended by Robert Bosch GmbH for the use of the named individual or entity to which it is directed and may contain information that is confidential or privileged. If you have received this electronic mail transmission in error, please delete it from your system without copying or forwarding it, and notify the sender of the error by reply email so that the sender's address records can be corrected.

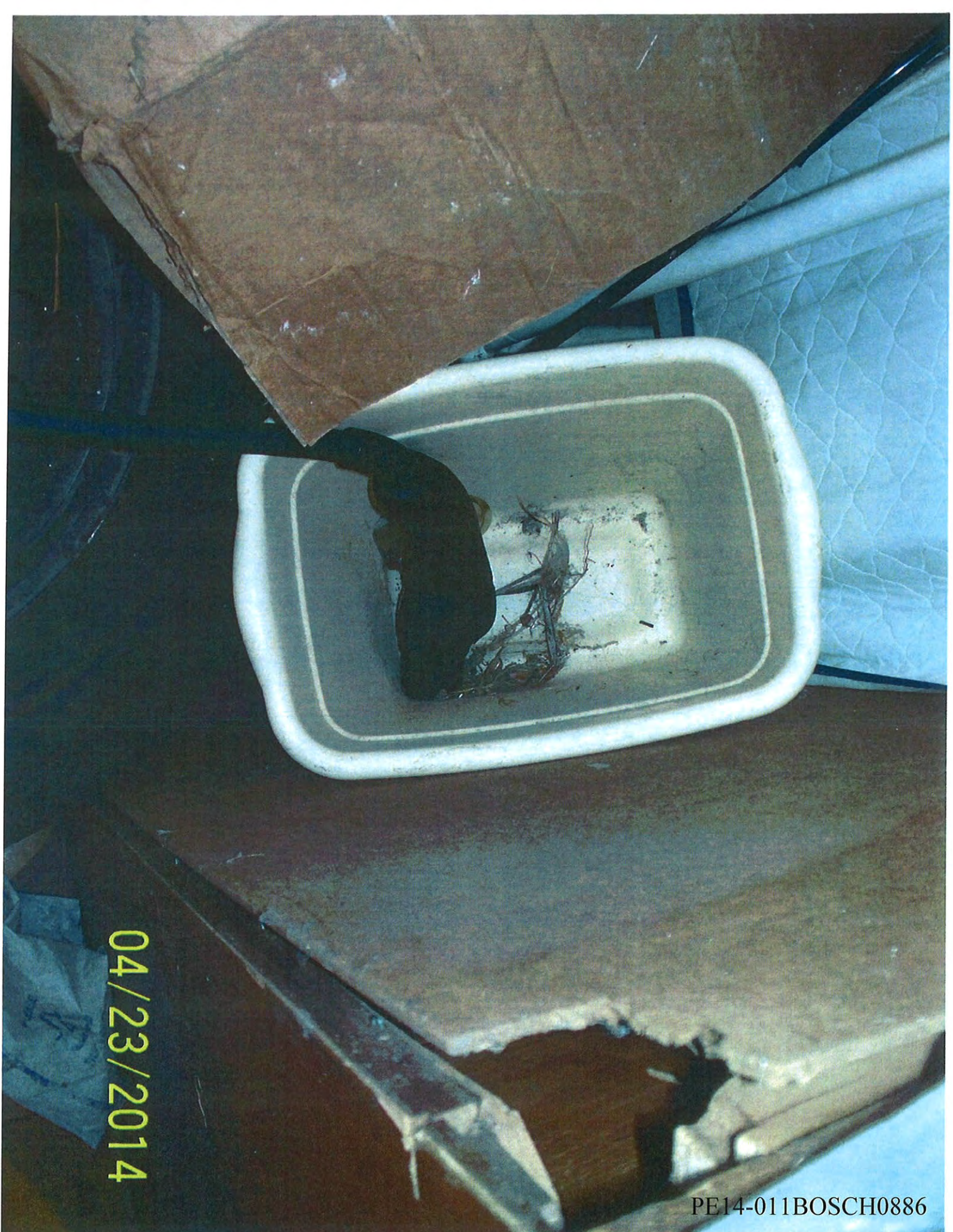

04/23/2014

PE14-011BOSCH0886



04/23/2014

PE14-011BOSCH0887

04/23/2014

PE 14-011  
BOSCH10888



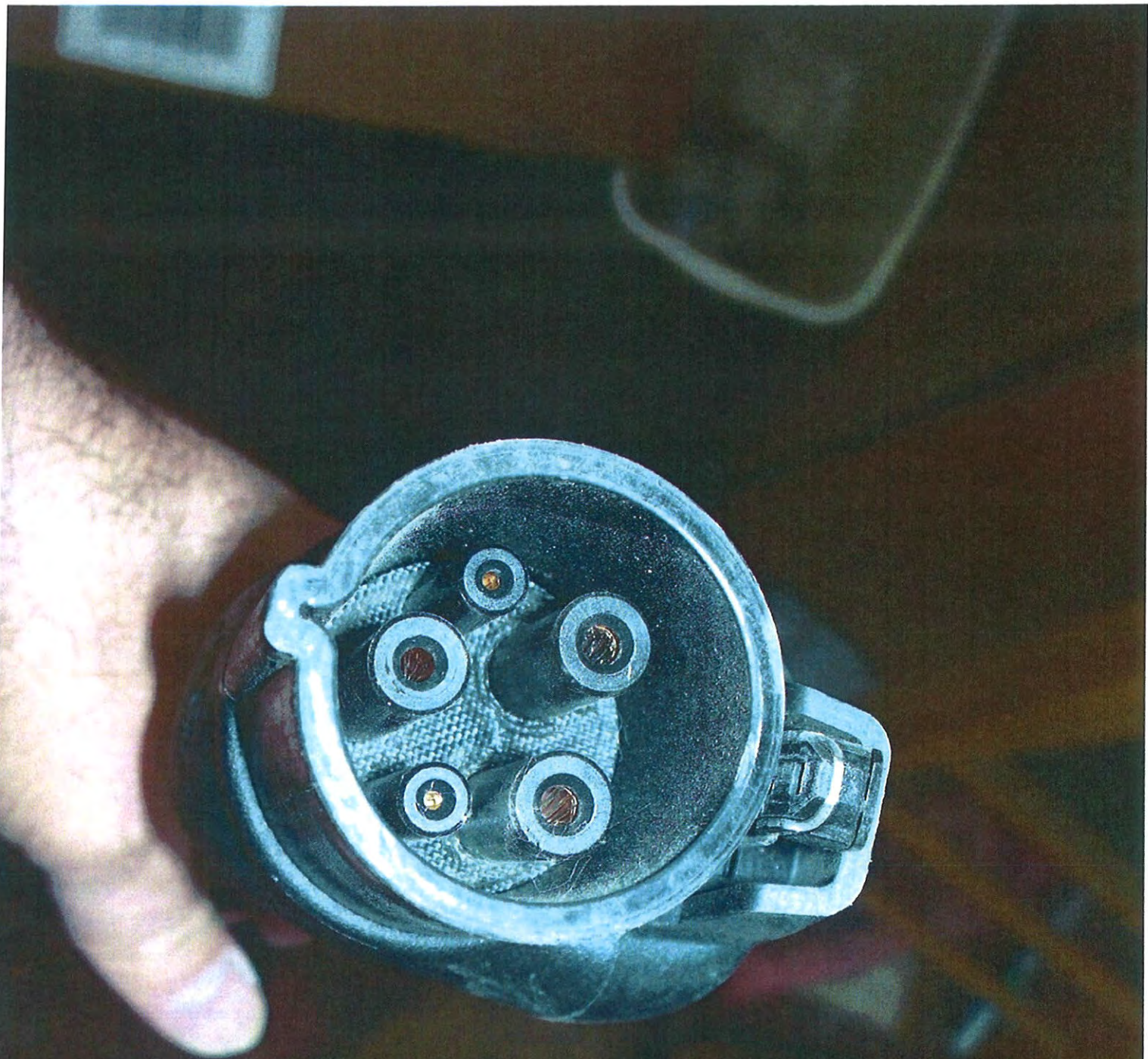

04/23/2014

PE1 PE14-011  
BOSCH0889

04/23/2014

PE14-01  
BOSCH 0890

90



04/23/2014



PE 14-011  
BOSCH 0892

04/23/2014

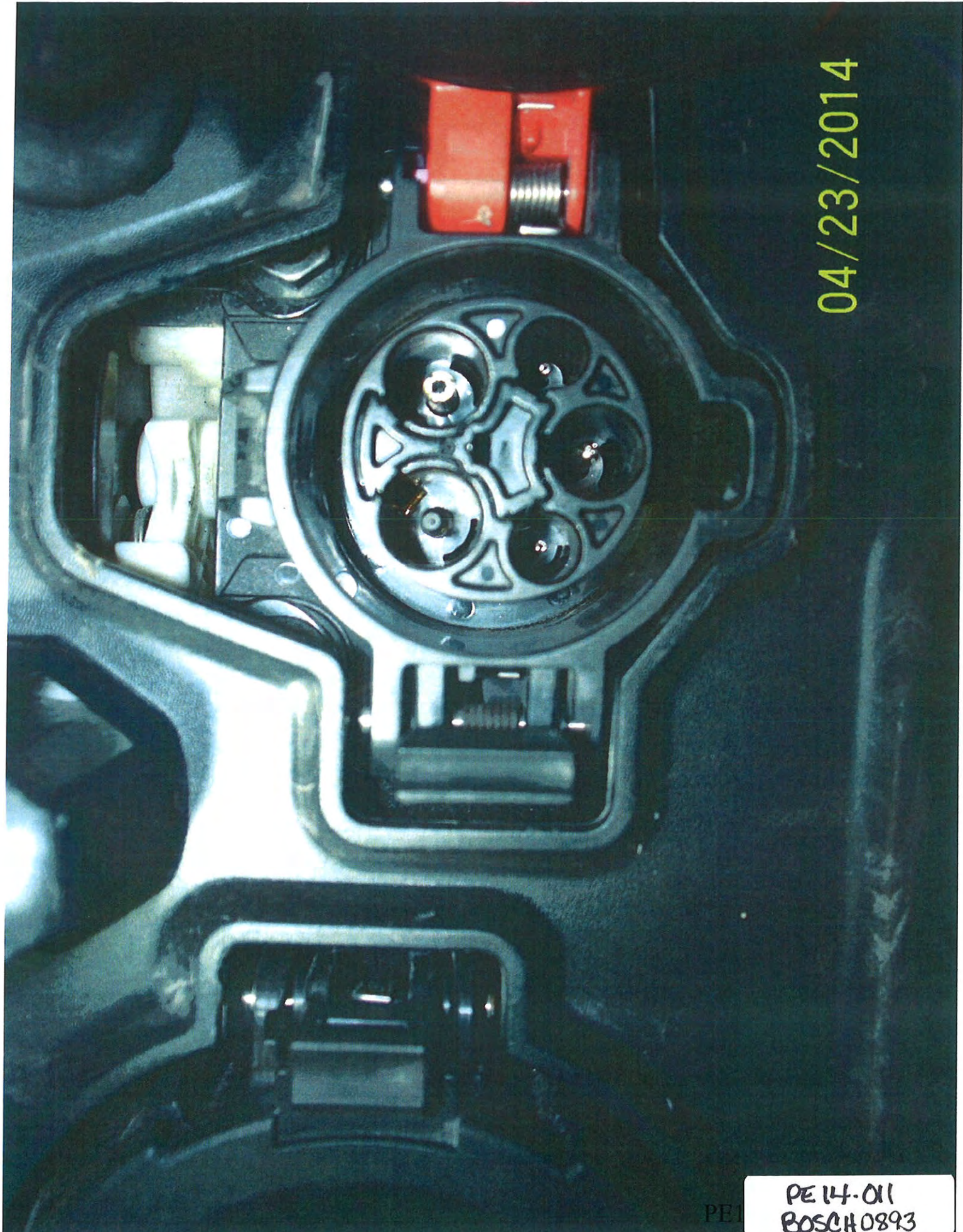

PE 1

PE 14-01  
BOSCH 0893

CAUTION / VORSICHT / ATTENTION  
/ CUIDADO / ATENCÃO / FEM / 5017

04/23/2014

PE  
PE 14-011  
BOSCH 0894

TAB 9A

STUCK COUPLER  
CITY OF MAGG  
5/20/14 # J1



STUCK COUPLER  
CITY OF MAGG

5/20/14 #J1



STUCK COMPLER  
CITY OF MAGGG

5/20/14 #J1



PE14-011BOSCH0918

#51

5/20/14



PE14-011BOSCH0919

STUCK COUPLER  
CITY OF MAGG  
5/20/14 #J1

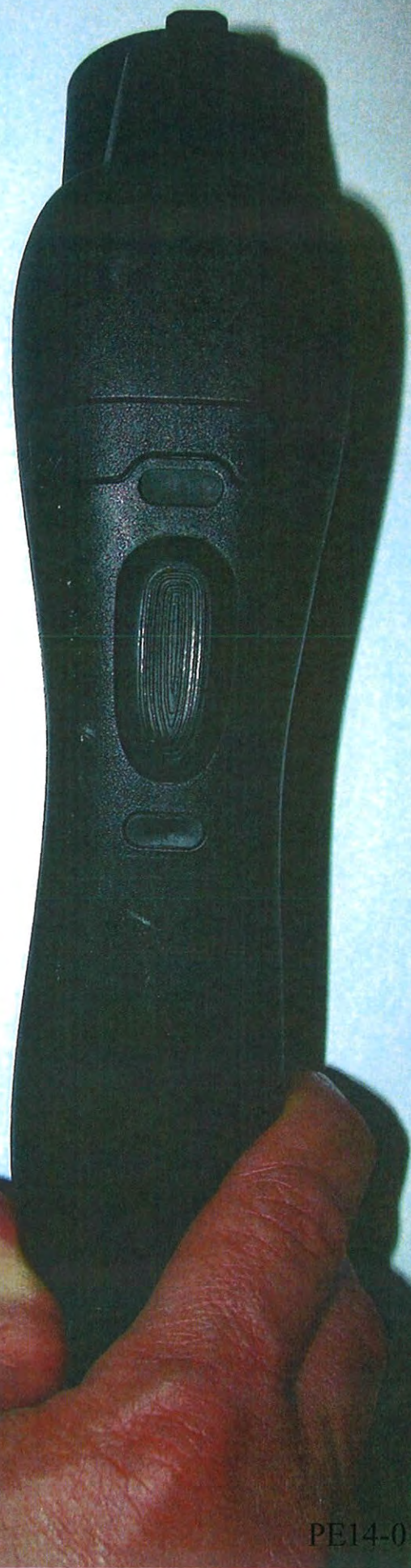

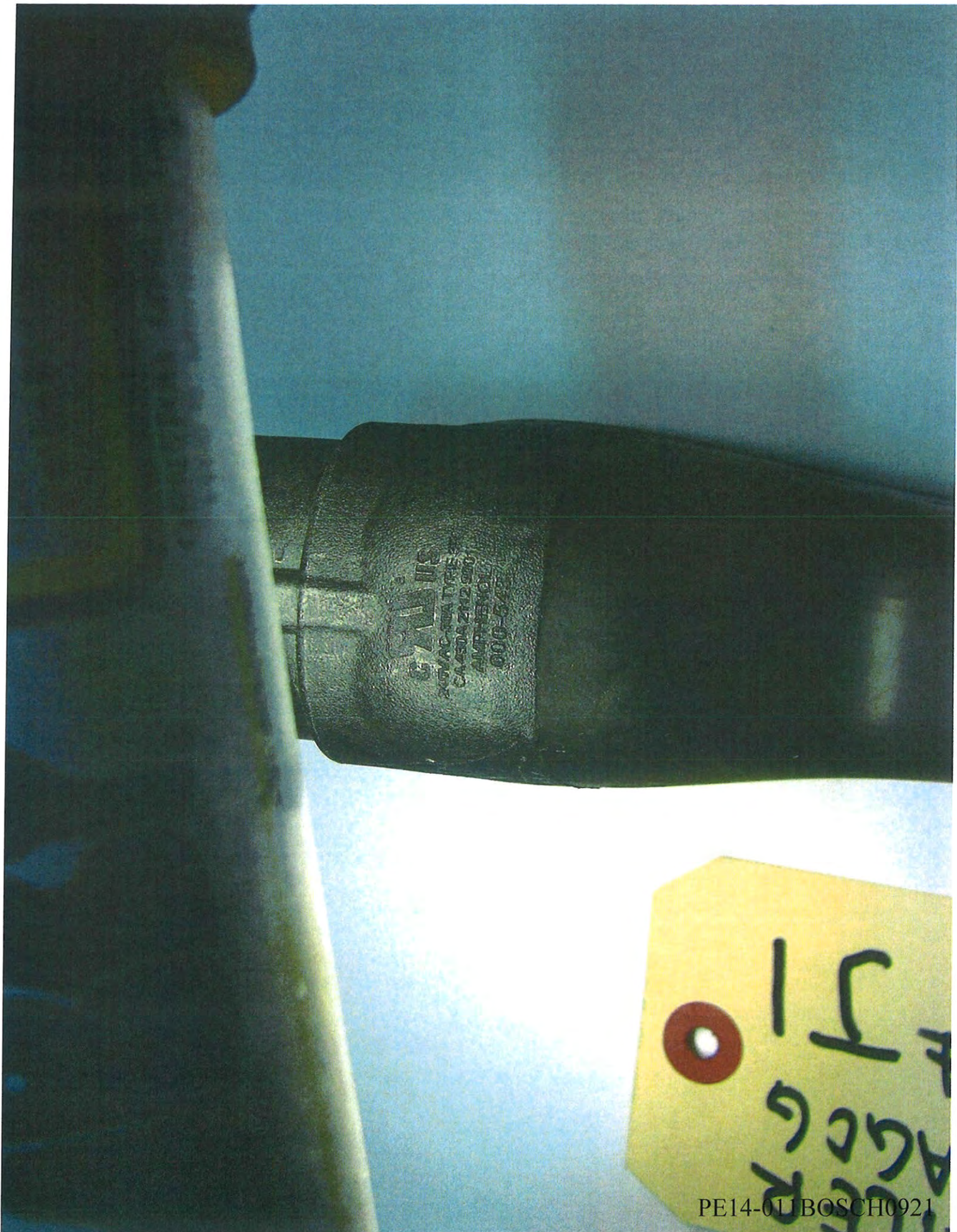

EVALIIS  
STAINLESS STEEL  
CALIBER 12 GA  
AMPHIBIOUS  
000-775

Handwritten text on a yellow tag:  
A  
G  
G  
1  
J  
A red hole is punched in the tag.

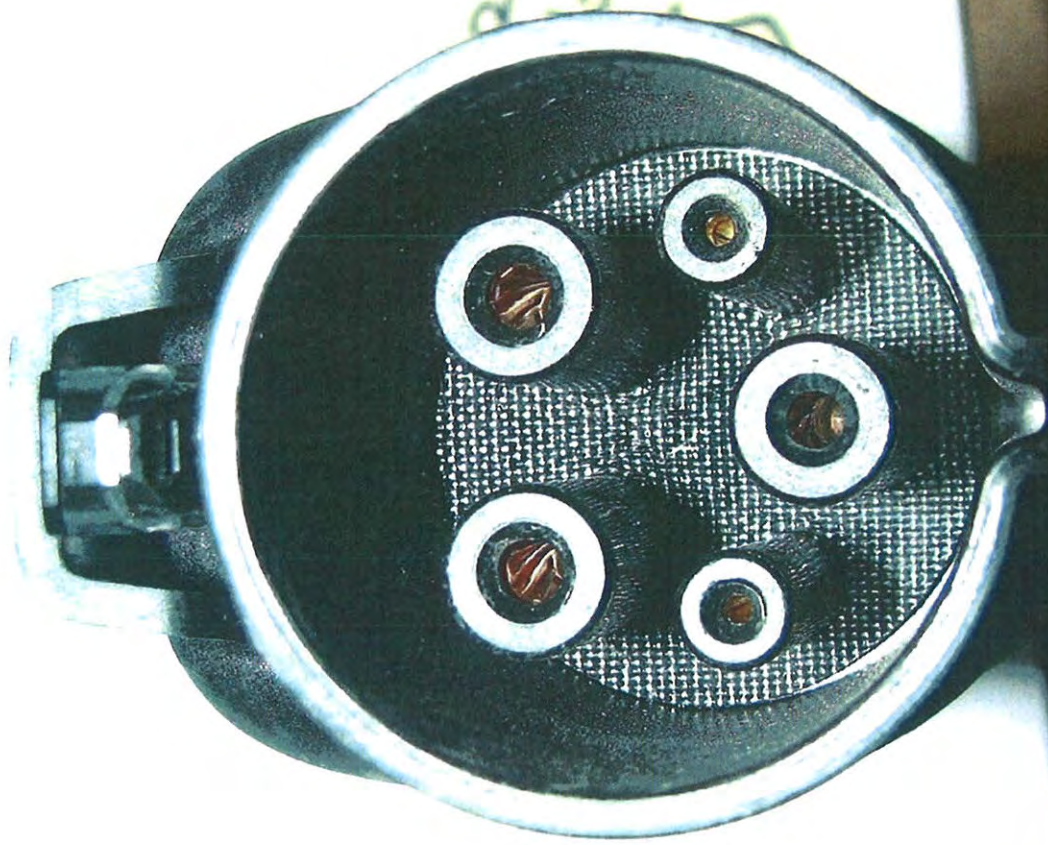

P PE 14-011  
BOSCH0922

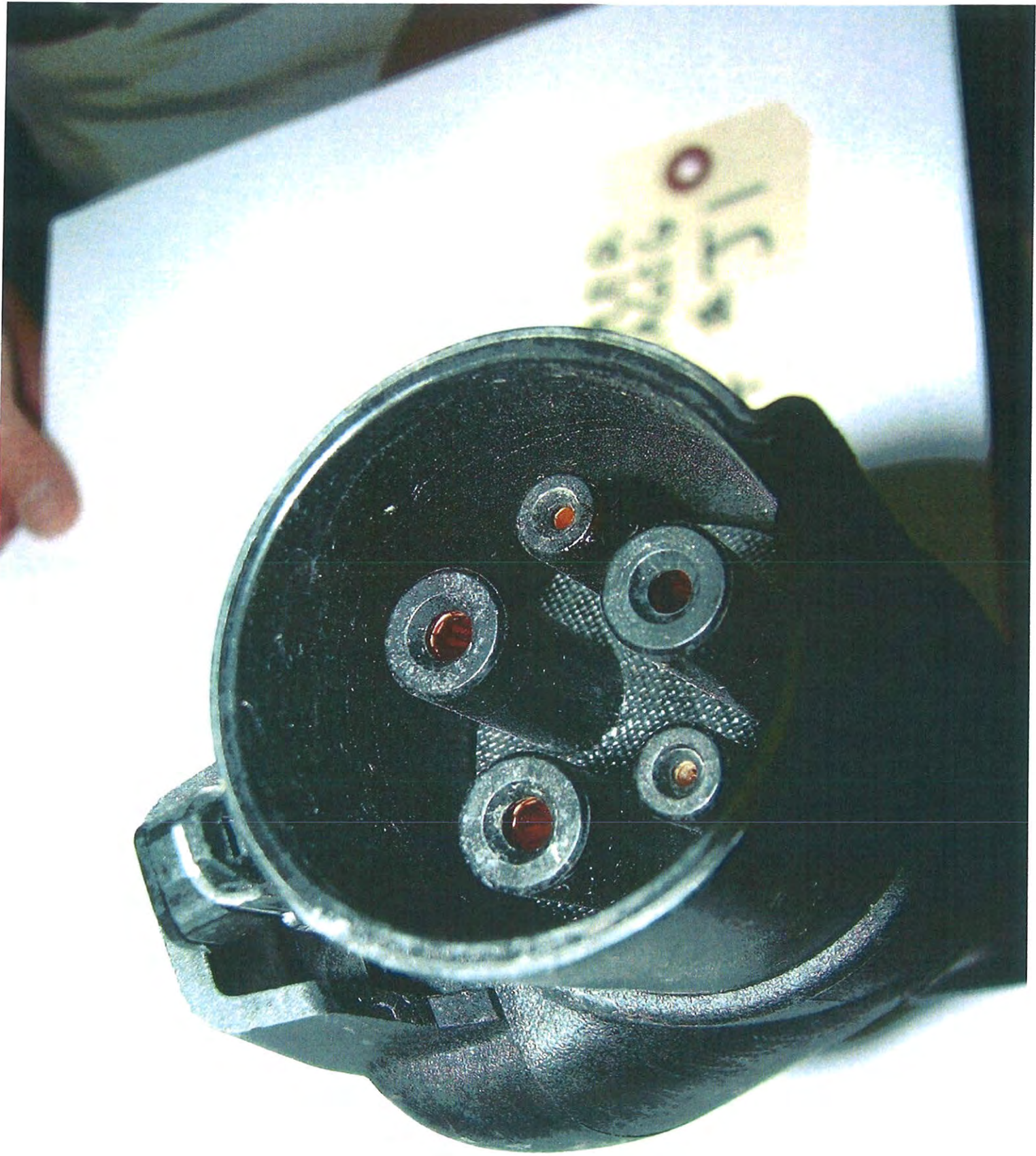

PE14-011BOSCH0923

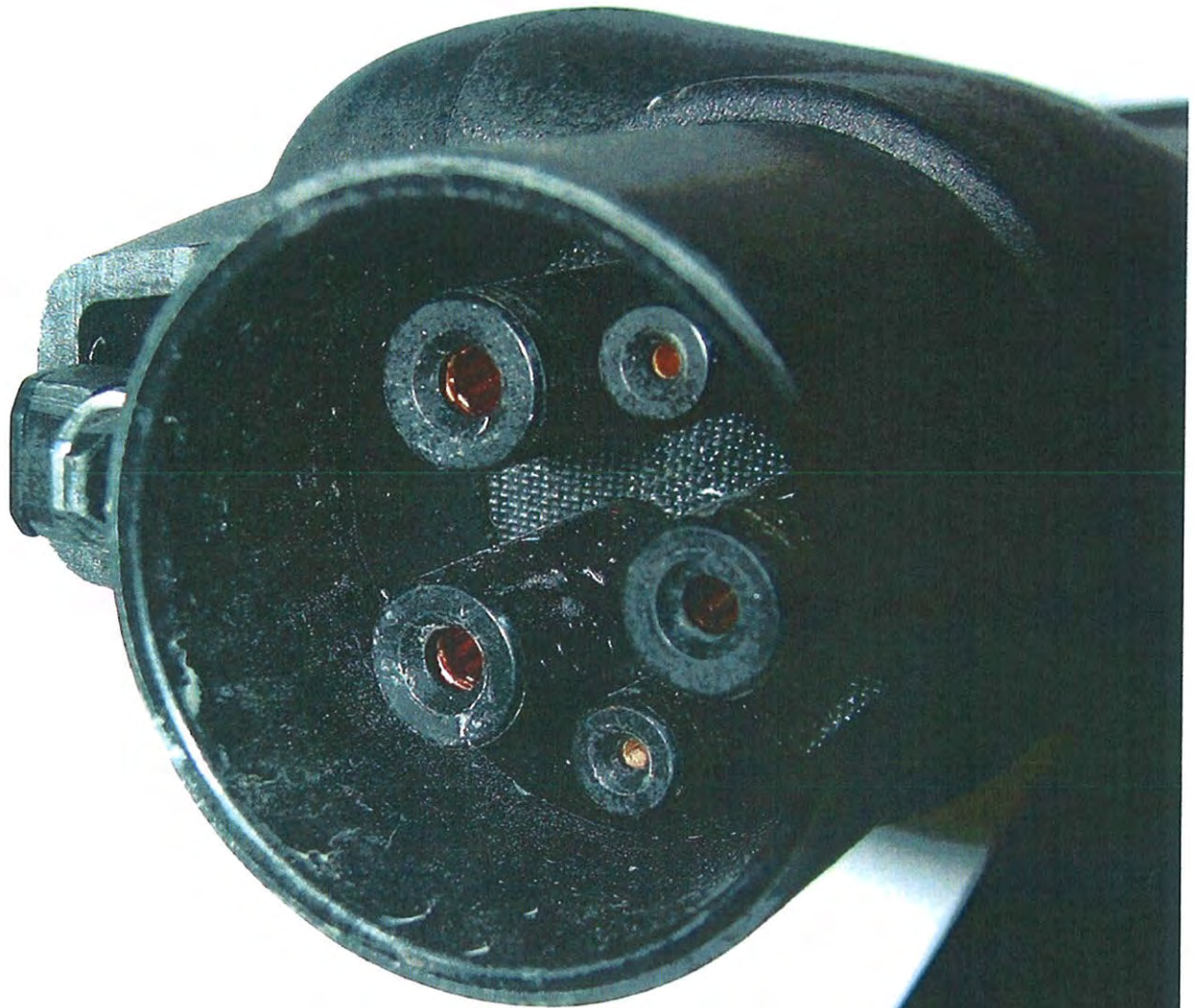

PEI

PE 14-011  
BOSCH 0924



## TAB 10

(See documents contained in TAB 9)

TAB 11

(See documents contained in TAB 9)

TAB 13A

---

**From:** [REDACTED]  
**Sent:** Wednesday, April 30, 2014 3:45 PM  
**To:** [REDACTED]  
**Subject:** RE: Another warranty claim for bad coupler

Have the customer call technical support at [REDACTED] option 4.

Thank you,

[REDACTED]

Bosch Automotive Aftermarket  
Automotive Service Solutions  
EVSE Project Coordinator (AA-AS)

[REDACTED]

The information contained in this electronic mail transmission is intended by Robert Bosch GmbH for the use of the named individual or entity to which it is directed and may contain information that is confidential or privileged. If you have received this electronic mail transmission in error, please delete it from your system without copying or forwarding it, and notify the sender of the error by reply email so that the sender's address records can be corrected.

**From:** [REDACTED]  
**Sent:** Wednesday, April 30, 2014 3:44 PM  
**To:** [REDACTED]  
**Subject:** Another warranty claim for bad coupler

H [REDACTED]

We have another customer with a Power Xpress vehicle coupler that went bad. This is an SPX one that we purchased and installed independently on 9/24/13, serial number 004339.

What do we need to do to initiate a claim?

Thanks!



SECRET



---

**From:** [REDACTED]  
**Sent:** Friday, May 09, 2014 12:04 PM  
**To:** [REDACTED]  
**Subject:** RE: High Importance

I recently sent Puget Sound Solar LLC a warranty replacement PX cord. They are going to be sending it back here to Mike Muller.

[REDACTED]

Thank you,

[REDACTED]  
[REDACTED]  
Bosch Automotive Aftermarket  
Automotive Service Solutions  
EVSE Project Coordinator (AA-AS)

[REDACTED]

The information contained in this electronic mail transmission is intended by Robert Bosch GmbH for the use of the named individual or entity to which it is directed and may contain information that is confidential or privileged. If you have received this electronic mail transmission in error, please delete it from your system without copying or forwarding it, and notify the sender of the error by reply email so that the sender's address records can be corrected.

-----  
**From:** [REDACTED]  
**Sent:** Friday, May 09, 2014 12:02 PM  
**To:** [REDACTED]  
**Subject:** High Importance

Can you please send me the address for Kaya Bekrioglu? He bought a power xpress from us.  
Sent from my iPhone



---

**From:** [REDACTED] (SS2.2-NA)  
**Sent:** Monday, May 12, 2014 12:26 PM  
**To:** [REDACTED] (AS/MK); [REDACTED] (AA-AS/PMS1)  
**Cc:**  
**Subject:** Ticket Number 148953 Contact Name [REDACTED]  
**Attachments:** Ticket Number148953Contact Name [REDACTED].tif; ticket 148953 - coupler front view.jpg;  
ticket 148953 - coupler side view.jpg



PE14-011  
BOSCH10942



PE 14-011  
BOSCH 0943



---

**From:** EXTERNA [REDACTED]  
**Sent:** Wednesday, May 14, 2014 9:19 AM  
**To:** [REDACTED] (AS/MK)  
**Cc:** [REDACTED] (S/SBD-NA) [REDACTED] (A-AS/SBD-NA)  
**Subject:** FW: [REDACTED] Replacement

[REDACTED]

Please see the below email from Jeremy Smithson at Puget Sound Solar. Puget Sound Solar is a Bosch Certified Electrical Contractor that purchased 15 of the EL-50600-X on April 17, 2013. They are now out of warranty and he's worried his customers could have the same issues with the connector.

Thank you,  
[REDACTED]  
[REDACTED]

Bosch Automotive Aftermarket  
Automotive Service Solutions  
EVSE Project Coordinator (AA-AS)

[REDACTED]

The information contained in this electronic mail transmission is intended by Robert Bosch GmbH for the use of the named individual or entity to which it is directed and may contain information that is confidential or privileged. If you have received this electronic mail transmission in error, please delete it from your system without copying or forwarding it, and notify the sender of the error by reply email so that the sender's address records can be corrected.

**From:** [REDACTED]  
**Sent:** [REDACTED]  
**To:** [REDACTED]  
**Subject:** [REDACTED] X Replacement

Yes, and we're sending the original cord back today.

We bought 15 of those Power Xpress units with 25' cords. I am concerned that other customers will have the same issue with the connector.

On Tue, May 13, 2014 at 8:01 AM, EXTERNA [REDACTED] (Adecco, Automotive-Service-Solutions)

Thanks. Did you swap out [REDACTED] cord?

Thank you,

[REDACTED]

Bosch Automotive Aftermarket

Automotive Service Solutions

EVSE Project Coordinator (AA-AS)

[REDACTED]

[REDACTED]

The information contained in this electronic mail transmission is intended by Robert Bosch GmbH for the use of the named individual or entity to which it is directed and may contain information that is confidential or privileged. If you have received this electronic mail transmission in error, please delete it from your system without copying or forwarding it, and notify the sender of the error by reply email so that the sender's address records can be corrected.

**From:** [REDACTED]  
**Sent:** Tuesday, May 13, 2014 10:56 AM  
**To:** [REDACTED]  
**Subject:** Re: Jeff Wells - PX Replacement

OK, got it.

[REDACTED] (Adecco, Automotive-Service-Solutions)

Hi [REDACTED]

I left a message with [REDACTED] at your company.

[REDACTED]

[REDACTED]

I just spoke with [REDACTED] regarding his Power Xpress charging station. He only needs the cord replaced, however we do not have any in stock currently. I will be sending a whole new charger to replace the other one. I informed him that this was not installed through Bosch and that we will not be covering any costs on swapping the charger out. Your company will need to invoice Jeff and not Bosch for the work being completed. I placed the order to have the replacement shipped to you, please contact him as soon as you receive it. You will also be responsible for returning the defective charger. Please see the below instructions for the return:

I have created Return Goods Authorization (RGA) number 251085. You will be receiving two emails. The first email is an RGA document, please print that out and place it inside the box you're returning. You may use the box the new charger comes in.

The second email will be a pre-paid shipping label. There will be a link within the email that says "Retrieve Your Label." Click that and a window will open, print that label and tape it on the outside of the box you're returning and take it to a UPS store.

Return the defective item within 14 business days of receiving the replacement to avoid any deductions of the hardware cost from payments on other jobs.

**It's imperative that we receive the defective charger back as soon as you swap it out. Please package the charger and cord very well to not damage the item any further. It needs to be inspected for cause of failure.**

Thank you,

[REDACTED]

[REDACTED]

Bosch Automotive Aftermarket

Automotive Service Solutions

EVSE Project Coordinator (AA-AS)

[REDACTED]

[REDACTED]

The information contained in this electronic mail transmission is intended by Robert Bosch GmbH for the use of the named individual or entity to which it is directed and may contain information that is confidential or privileged. If you have received this electronic mail transmission in error, please delete it from your system without copying or forwarding it, and notify the sender of the error by reply email so that the sender's address records can be corrected.





---

**From:** [REDACTED]  
**Sent:** Thursday, May 22, 2014 9:19 PM  
**To:** [REDACTED]  
**Subject:** Re: Jeff Wells - PX Replacement

Yes, that is happening tomorrow.

On Thu, May 22, 2014 at 11:29 AM, EXTERNAL ([REDACTED] Adecco, Automotive-Service-Solutions)

[REDACTED]

Have you scheduled [REDACTED] swap out?

Thank you,

[REDACTED]

Bosch Automotive Aftermarket  
Automotive Service Solutions  
EVSE Project Coordinator (AA-AS)

[Redacted]

The information contained in this electronic mail transmission is intended by Robert Bosch GmbH for the use of the named individual or entity to which it is directed and may contain information that is confidential or privileged. If you have received this electronic mail transmission in error, please delete it from your system without copying or forwarding it, and notify the sender of the error by reply email so that the sender's address records can be corrected.

---

**From:** [Redacted]  
**Sent:** Wednesday, May 21, 2014 3:19 PM  
**To:** [Redacted]  
**Subject:** RE: [Redacted] - PX Replacement

Please let me know the install date once you've scheduled it.

Thank you,

[Redacted]

Bosch Automotive Aftermarket  
Automotive Service Solutions  
EVSE Project Coordinator (AA-AS)

[Redacted]

[Redacted]

[REDACTED]

The information contained in this electronic mail transmission is intended by Robert Bosch GmbH for the use of the named individual or entity to which it is directed and may contain information that is confidential or privileged. If you have received this electronic mail transmission in error, please delete it from your system without copying or forwarding it, and notify the sender of the error by reply email so that the sender's address records can be corrected.

**From:** [REDACTED]

**Sent:** Wednesday, May 21, 2014 2:10 PM

**To:** [REDACTED]

**Subject:** [REDACTED] FX Replacement

Yes, we are scheduling this a.s.a.p., thanks.

On Wed, May 21, 2014 at 10:11 AM, EXTERNAL [REDACTED]

[REDACTED] wrote:

Please contact Jeff to schedule the swap out. We will also need you to return the defective charger right after swapping it out with the new one.

The charger was delivered to you Monday, May 19.

Please let me know once you have contacted Jeff and scheduled the installation.

Thank you,

[REDACTED]

[REDACTED]

Bosch Automotive Aftermarket

Automotive Service Solutions

EVSE Project Coordinator (AA-AS)

[REDACTED]

The information contained in this electronic mail transmission is intended by Robert Bosch GmbH for the use of the named individual or entity to which it is directed and may contain information that is confidential or privileged. If you have received this electronic mail transmission in error, please delete it from your system without copying or forwarding it, and notify the sender of the error by reply email so that the sender's address records can be corrected.

**From:** [REDACTED]

**Sent:** Tuesday, May 13, 2014 10:56 AM

**To:** [REDACTED]

**Subject:** Re: [REDACTED] - PX Replacement

OK, got it.

On Mon, May 12, 2014 at 1:24 PM, EXTERNAL [REDACTED]

Hi [REDACTED]

I left a message with [REDACTED] at your company.

[REDACTED]



I just spoke with [REDACTED] regarding his Power Xpress charging station. He only needs the cord replaced, however we do not have any in stock currently. I will be sending a whole new charger to replace the other one. I informed him that this was not installed through Bosch and that we will not be covering any costs on swapping the charger out. Your company will need to invoice Jeff and not Bosch for the work being completed. I placed the order to have the replacement shipped to you, please contact him as soon as you receive it. You will also be responsible for returning the defective charger. Please see the below instructions for the return:

I have created Return Goods Authorization (RGA) number 251085. You will be receiving two emails. The first email is an RGA document, please print that out and place it inside the box you're returning. You may use the box the new charger comes in.

The second email will be a pre-paid shipping label. There will be a link within the email that says "Retrieve Your Label." Click that and a window will open, print that label and tape it on the outside of the box you're returning and take it to a UPS store.

Return the defective item within 14 business days of receiving the replacement to avoid any deductions of the hardware cost from payments on other jobs.

**It's imperative that we receive the defective charger back as soon as you swap it out. Please package the charger and cord very well to not damage the item any further. It needs to be inspected for cause of failure.**

Thank you,



Bosch Automotive Aftermarket

Automotive Service Solutions

EVSE Project Coordinator (AA-AS)



The information contained in this electronic mail transmission is intended by Robert Bosch GmbH for the use of the named individual or entity to which it is directed and may contain information that is confidential or privileged. If you have received this electronic mail transmission in error, please delete it from your system without copying or forwarding it, and notify the sender of the error by reply email so that the sender's address records can be corrected.

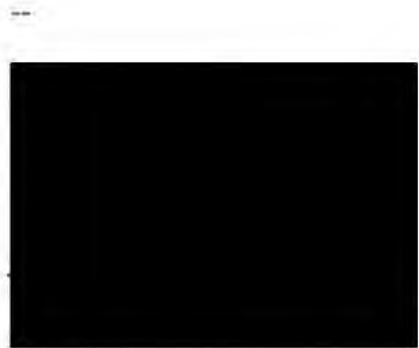

--



# ATTACHMENT D

TAB 2

---

**From:** [REDACTED]  
**Sent:** Tuesday, September 24, 2013 9:57 AM  
**To:** [REDACTED]  
**Cc:** [REDACTED] AA-AS/SBD-NA)  
**Subject:** Customer Concern

[REDACTED]  
Good morning,

Sorry for the delay in my response.

This was an isolated incident that Bosch decided to take immediate action on to satisfy our customer. To date we have distributed and/or installed over 5,000 Power Xpress Charge Stations and have very high rate of customer satisfaction and an extremely low rate of customer concerns. We do take every customer concern very seriously. We are fully investigating this incident and will implement corrective action if required.

Please consider this response as confidential between Honda and Bosch.

Thanks,

[REDACTED]  
Bosch Automotive Aftermarket  
Automotive Service Solutions  
Director, Business Development (AA-AS)

[REDACTED]

The information contained in this electronic mail transmission is intended by Robert Bosch GmbH for the use of the named individual or entity to which it is directed and may contain information that is confidential or privileged. If you have received this electronic mail transmission in error, please delete it from your system without copying or forwarding it, and notify the sender of the error by reply email so that the sender's address records can be corrected.

**From:** [REDACTED]  
**Sent:** Tuesday, September 24, 2013 1:16 AM  
**To:** [REDACTED]  
**Cc:** [REDACTED]  
**Subject:** Re: Connector overheating issue

Hello [REDACTED]  
I know this is a delicate topic, but it is also a serious issue for vehicle OEMs. It would be appreciated if you could provide update about it.  
Best regards,





## Power Xpress Charge Station



en Installation and Operating Instructions

PE14-011BOSCH1045



Copyright © 2013 Bosch Automotive Service Solutions LLC  
All rights reserved.

The information, specifications, and illustrations in this guide are based on the latest information available at the time of printing. Bosch Automotive Service Solutions LLC reserves the right to make changes at any time, without notice.

PE14-011BOSCH1046

## Table of Contents

<b>Safety</b>	<b>2</b>
<b>Regulatory Information</b>	<b>3</b>
Environmental Considerations	3
Product Specification	3
FCC Declaration of Conformity	3
Radio and Television Interference	3
Agency Approvals	3
<b>Features and Specifications</b>	<b>3</b>
Ground-fault protection	3
Automatic reset	3
Ground Assurance Monitoring	3
Self-testing	3
Product Features	4
Technical Specifications	4
<b>Package Contents</b>	<b>5</b>
Optional Kit #1 Contents (EL-50600-2)	5
Optional Kit #2 Contents (EL-50600-5)	5
Tools Suggested for Installation	5
Possible Materials Needed	5
<b>Applicable Electrical Systems</b>	<b>6</b>
220/240V Single Phase (North America)	6
208V 3-Phase Wye Connection (North America)	6
240V 3-Phase Delta Connection (North America)	7
230V Above Ground (Europe) 230V Single Phase	7
<b>Electrical Requirements for Battery Charging</b>	<b>8</b>
<b>Amperage and Breaker Parameters</b>	<b>8</b>
<b>Charge Station Mounting Instructions</b>	<b>8</b>
Mounting Template	8
Finished Wall Charge Station Installation	9
Masonry Wall Charge Station Installation	13
Molded Plug-Connected Charge Station Installation	16
<b>Operating Instructions</b>	<b>19</b>
Power and Status LED Indications	19
<b>Troubleshooting</b>	<b>20</b>
Ground Fault Circuit Interrupt (GFCI) Tripped	20
Missing Ground	20
<b>Maintenance</b>	<b>21</b>
<b>Cleaning</b>	<b>21</b>
<b>Storage and Moving</b>	<b>21</b>
<b>Limited Warranty</b>	<b>22</b>
Disclaimer	22
Legal Limitation of Liability	22
Copyrights, Trademarks	22

## Safety

Save these instructions. Read all instruction before installing or using the Power Xpress Charge Station.

- ▲ **WARNING:** Turn OFF the circuit breaker at the service or distribution panel before performing any electrical work or repairs.
- ▲ **WARNING:** The Charge Station must be installed by a licensed electrician in accordance with all local electrical codes, ordinances, and all authorities having jurisdiction.
- ▲ **WARNING:** Do not install the Charge Station near flammable, explosive, or combustible materials. Do not locate or store flammable, explosive, or combustible materials near the Charge Station.
- ▲ **WARNING:** The Charge Station contains no user-serviceable parts. Do not attempt to repair or service the Charge Station yourself. If the Charge Station requires servicing, contact Bosch.
- ▲ **WARNING:** Adult supervision is required when using the Charge Station around children.
- ▲ **WARNING:** Do not put fingers into the Charge Station electric vehicle connector.
- ▲ **WARNING:** Disconnect main service power to the Charge Station before cleaning the unit. Do not use cleaning solvents to clean any part of the Charge Station. Clean enclosure, cable and connector with a clean, dry cloth to remove dust and dirt accumulation.
- ▲ **WARNING:** If the device repeatedly trips, seek advice from Bosch.
- ▲ **WARNING:** Use/operate Charge Station: (1) In a well-lit area and away from high pedestrian traffic to avoid accidental tripping hazard. (2) away from areas of child activity to avoid potential shock hazards.
- ▲ **WARNING:** Disconnect main service supply or unplug unit to achieve electrical isolation.
- ▲ **WARNING:** Do not tamper with or modify this device.
- ▲ **WARNING:** If Charge Station fails to operate correctly in accordance with the operation manual, do not use this device. Contact Bosch for repair or replacement.
- ▲ **WARNING:** Improper installation of the Charge Station can result in personal injury or product damage.
- ▲ **WARNING:** This Charge Station installation guide is not a substitute for electrical safety precautions.
- ▲ **WARNING:** Use this Charge Station within the specified operating parameters. Failure to do so may result in injury or death.
- ▲ **WARNING:** Locate and install this Charge Station in a location where the charge cable will not be stepped on, tripped over, or subject to damage or stress.
- ▲ **WARNING:** The Charge Station must be connected to a grounded, metal, permanent wiring system, or an equipment-grounding conductor must be run with the circuit conductors and connected to the equipment grounding terminal on the Charge Station.
- ⚠ **CAUTION:** Incorrect installation of the Charge Station can result in damage to the vehicle's battery and to the Charge Station itself. These damages will void the warranty for the vehicle and the Charge Station.
- ⚠ **CAUTION:** Do not operate the Charge Station in temperatures beyond its operating range of -40°F to +122°F (-40°C to +50°C).

## Regulatory Information

### Environmental Considerations

At the end of service life, the Charge Station should be recycled according to local laws and regulations.



### Product Specification

All Charge Station specifications and descriptions are accurate at the time of this document's printing. We always strive to constantly improve and update our products, Bosch reserves the right to make changes at any time, without notice and without obligation.

### FCC Declaration of Conformity

This device complies with Part 15 Class-B of the FCC rules. Operation is subject to the following two conditions: 1) This device may not cause harmful interference, and 2) this device must accept any interference received, including interference that may cause undesired operation.



#### Note:

Non-authorized changes or modifications to this product could void its FCC compliance.

### Radio and Television Interference

The equipment described in this manual has been designed to protect against Radio Frequency Interference (RFI). However, there are some instances where high-powered radio signals or nearby RF-producing equipment (such as digital phones, RF communications equipment, etc.) could affect Charge Station operations. If interference to the Charge Station occurs during charging, contact Bosch.



### Agency Approvals

Standard Compliances through a National Registered Testing Lab (NRTL)

#### North American Operation

FCC Part 15 Class-B  
UL 2594  
UL 2251  
UL 62  
UL 60950-1  
UL 1998  
UL 2231-1 & -2  
CSA C22.2 #60950-1  
CSA C22.2 #107.1  
SAE J1772  
NEC Article 625

#### European Union Operation

IEC 61851-1  
IEC 61851-21 & -22  
IEC 60950-1  
IEC 61000-6-1 EMC Immunity  
IEC 61000-6-3 EMC Emissions  
IEC 62196 Coupler, Type 1, Type 2  
IEC 60204-1, Safety for servicing electronic equipment

## Features and Specifications

The Charge Station includes ground-fault protection, automatic reset upon grid power loss, ground assurance monitoring, and self-testing capabilities. Manual resetting of the Charge Station is not necessary. Exception: European models require manual resetting after ground fault condition.

### Ground-fault protection

Continually provides a safe power supply to the vehicle. If a ground fault is present, the Charge Station detects it and cuts power flow, protecting people and the vehicle from an electric shock hazard.

### Automatic reset

If main line side power supply is interrupted during charging, the Charge Station will reset itself automatically and re-attempt charging after main line side power supply is restored.

If the problem is associated with a ground fault, the Charge Station makes a total of 4 automatic reset attempts in sequential 15-minute periods. If the charging mode can not be restored, the appropriate failure indication will be shown on the unit's front panel. NOTE: Not applicable on European models; European models require pressing of the master clear "Reset" button on the front panel of the Charge Station to restore power.

See Table-A in Operating Instructions for LED status indications (page 11).

The automatic reset feature assures that your vehicle will be charged and ready to use by automatically restoring power after temporary interruptions (grid-power outages, temporary ground faults [US models only] and power surges).

### Ground Assurance Monitoring

A proper electrical ground is critical to reliable ground-fault protection, the Charge Station includes a ground monitoring circuit to assure presence of a safe electrical ground.

### Self-testing

To assure proper functionality and safety, the Charge Station includes self-testing and diagnostics circuitry, which is automatically performed prior to each charging cycle.

**Product Features**

<b>Voltage and Wiring (120V above ground)</b>	<ul style="list-style-type: none"> <li>• 240VAC single-phase: L1, L2, and safety ground. •</li> <li>• 208VAC 3-phase, wye-connected: Any 2 phases and safety ground.</li> <li>• 240VAC 3-phase, delta-connected: with center tap on one leg, use only the two phases on either side of the center tap. The two phases must both measure 120V AC to ground. Do not use the third leg (208V “stinger”)</li> </ul>
<b>Voltage and Wiring (230V above ground - Europe)</b>	230V AC single-phase: LINE, NEUTRAL, and EARTH
<b>Current and Frequency</b>	Current—Model dependent; see unit specification label 50/60Hz
<b>Cable Length and Connector</b>	Maximum 25 ft (7.6 m) per NEC 625—Model dependent; see unit specification label (18 ft (5.5 m) typical)
<b>Dimensions</b>	14.5 in. (368.3 mm) height × 5.2 in. (132 mm) width × 4.3 in. (109.2) depth
<b>Weight</b>	Approximately 16 pounds w/25 ft (7.6 m) cable and coupler
<b>Operating Temperature Storage Temperature</b>	-40°F to +122°F (-40°C to +50°C) -58°F to +176°F (-50°C to +80°C)
<b>Ratings and Agency Approvals</b>	Enclosure Type NEMA 4X – indoor/outdoor use, watertight <ul style="list-style-type: none"> <li>• ETL approved to UL and CSA standards•</li> <li>• CE compliant w/3rd-Party ETL testing•</li> <li>• FCC Part 15 Class-B compliant</li> </ul>

**Technical Specifications**

<b>Output Amperage</b>	32A Max, Model Dependent (see output spec. label on side of Charge Station)
<b>Input Voltage Range</b>	175 VAC – 264 VAC
<b>Frequency</b>	50/60Hz
<b>Ground Fault Trip Level</b>	17.5 mA (20mA Max)
<b>Ground Assurance</b>	50K ohm Max (North American), 100K ohm Max (Europe)
<b>Surge Protection</b>	6kV @3000A
<b>Operating Humidity</b>	Up to 95% non-condensing @1060hPa
<b>Operating Temperature</b>	-40°F to +122°F (-40°C to +50°C)
<b>Storage Temperature</b>	-58°F to +176°F (-50°C to +80°C)
<b>Ground Fault Test</b>	Automatic at startup (Firmware controlled)
<b>Ground Fault Retry</b>	4 automatic retries @ 15 min. intervals (per UL2231-2)—not applicable to European models
<b>Master Clear</b>	For System Reset (Overrides Ground Fault Retry and all other fault conditions)
<b>Power Indication</b>	Green LED
<b>Charge Status Indicators</b>	<ul style="list-style-type: none"> <li>• Amber (Ready)</li> <li>• Green (Plugged In)</li> <li>• Green Flashing (Charging)</li> <li>• Red Flashing (Fault)</li> </ul>
<b>Enclosure</b>	NEMA 4X & per UL 50E

## Package Contents

- (1) Charge Station (including attached cord and vehicle coupler) (EL-50600-1)
- (1) Wall-mounting bracket (EL-50600-1)
- (1) User Manual (EL-50600-7-2)
- (1) Wiring chamber cover (EL-50600-3)
- (1) Wiring chamber cover label (EL-50600-3)
- (4) 3/4-in. (20-mm) No.2 square-drive screws (EL-50600-5)
- (1) Rubber grommet (EL-50600-4)
- (1) Foam dust cover gasket (EL-50600-4)
- (1) 3/4-in. (20-mm) plastic bushing (EL-50600-4)
- (1) Small sealing plug (EL-50600-4)
- (1) Knockout plug

### Optional Kit #1 Contents (EL-50600-2)

- (1) Primary-side, 12-in. (305-mm) cable w/molded NEMA 6-30 plug
- (1) 3/4-in. (20-mm) NPT cable gland with nut and sealing washer

### Optional Kit #2 Contents (EL-50600-5)

- (6) #8 × 1 1/4-in. (32-mm) Phillips pan-head screws with plastic drywall anchors
- (3) 3/16 × 1 1/4-in. (5 × 32-mm) Phillips tapered-head masonry fastener screws

## Tools Suggested for Installation

- Stud finder
- Tape measure
- 2-ft (61-cm) level
- Chalk line
- Pencil
- Power drill
- #2 Phillips screwdriver
- #2 square-head screwdriver
- 3/16-in. (5-mm) flat-blade screwdriver
- 3/32-in. (2.5-mm) flat-blade screwdriver
- NM (non-metallic) wire stripper
- Wire cutters
- Wire stripper
- Needle-nose pliers
- Hammer
- Clear silicone
- 1/16-in. (2-mm) drill bit
- 1 1/16-in. (28-mm) hole-saw
- 1/8-in. (4-mm) masonry drill bit
- 3/16-in. (5-mm) drill bit
- Torque screwdriver with #2 Phillips-head bit and 3/16-in. (5-mm) slotted-head bit

## Possible Materials Needed

- (dependent upon installation type; not provided)
- 90° Fitting for liquid-tight flex conduit
- Male threaded EMT fitting with offset; 3/4-in. (20-mm)
- Locking nut for 3/4-in. (20-mm) male EMT with binding screw
- Sealing gasket for 3/4-in. (20-mm) male EMT fitting
- Male threaded PVC fitting; 3/4-in. (20-mm)
- Locking nut for 3/4-in. (20-mm) male PVC fitting
- Sealing gasket for 3/4-in. (20-mm) male PVC fitting
- PVC jake offset; 3/4-in. (20-mm)
- PVC coupler; 3/4-in. (20-mm)
- NM, UF, or 3G wire

## Applicable Electrical Systems

**IMPORTANT:** Identify the onsite service connection before installing the Charge Station. If you are unsure of the available service connection, consult the local utility company or contact Bosch Electric Vehicle Solutions at 1-877-805-EVSE (3873).

The L1, L2, and Ground outputs (H, N for Europe) in the following illustrations correspond to the inputs on the Charge Station.

For the (earth) ground connection, always connect the neutral at the service panel to earth ground. Ground fault protection is not possible unless the neutral (center tap on the service transformer) is connected to an earth ground.

### 220/240V Single Phase (North America)

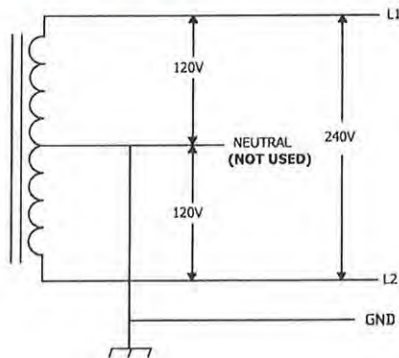

220/240V Single Phase

**⚠ WARNING:** The Charge Station is a single-phase device. Do not connect all three phases of a 3-phase feed. Only three wires are connected, take care that the service transformer secondary connection is known, and the three wires from the main-panel circuit breaker are correctly connected and labeled.

### 208V 3-Phase Wye Connection (North America)

Any two of the legs can be used to provide 208V to the Charge Station with a Wye-connected secondary. For example, L1 and L2, or L1 and L3, or L2 and L3. Reference the wiring diagram below.

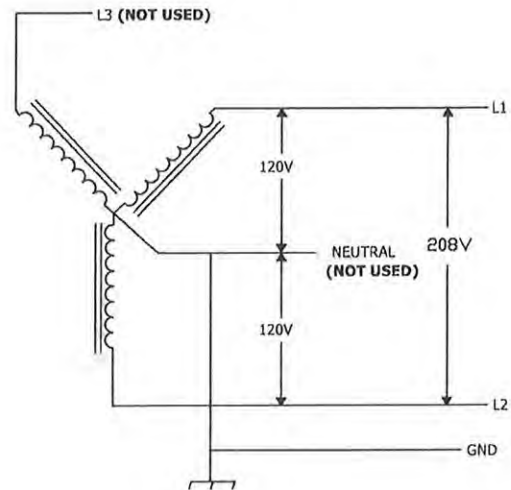

208V 3-Phase Wye Connection

**Note:**

A current-carrying neutral is not required for the Charge Station for 208V connections.

**⚠ WARNING:** The Charge Station must be installed by a licensed electrician and in accordance with all local electrical codes, ordinances, and all authorities having jurisdiction.

**⚠ WARNING:** Do not install the Charge Station near flammable, explosive, or combustible materials. Do not locate or store flammable, explosive, or combustible materials near the Charge Station.

### 240V 3-Phase Delta Connection (North America) with Center Tap on One Leg

One leg must be center-tapped, and only the two phases on either side of the center tap can be used with the delta connection.

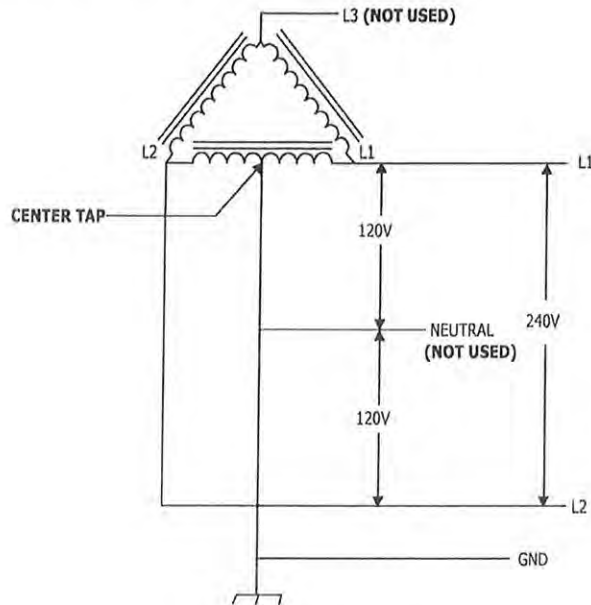

240V 3-Phase Delta Connection

**Note:**

The third line (L3 on the illustration of the delta) is 208V, with respect to the neutral, and is sometimes referred to as a “stinger.”

**⚠ WARNING: Do not use this third line.**

**Note:**

The two used phases must each measure 120V to neutral or ground.

**Note:**

Consult the utility company or the transformer manufacturer’s literature to verify that the single leg can supply the required power.

**Note:**

The Charge Station will only operate properly if it detects the presence of a ground wire connected to a neutral point on the transformer secondary.

**⚠ WARNING: Do not use a 3-phase delta-connected transformer secondary without a center tap on one leg and/or without a neutral point available for the required ground connection.**

### 230V Above Ground (Europe) 230V Single Phase

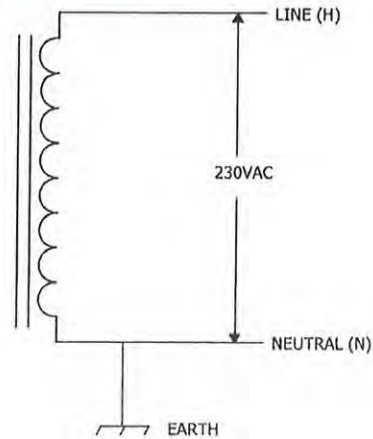

230V Single Phase

**⚠ WARNING: The Charge Station is a single-phase device. When connecting the line and neutral wires, take care that the service transformer secondary connection is known, and the wires from the main circuit breaker panel are correctly connected and labeled. The following service connections are primarily used in Europe and Australia (sometimes known as “TT Power Grid”). Please reference the following diagram. The line, neutral, and earth outputs on the illustration correspond to the inputs on the Charge Station.**

**⚠ WARNING: The line connection must measure 230V RMS to neutral. Earth must also be connected to the Charge Station.**

## Electrical Requirements for Battery Charging

**⚠ WARNING:** The Charge Station must be installed by a licensed electrician in accordance with all national and local electrical codes, ordinances, requirements, and all authorities having jurisdiction.

**⚠ CAUTION:** The AC electrical connection must have a grounded, dedicated service-main. No other loads shall be connected to the same circuit. Use of a non-dedicated circuit could exceed the current rating of the circuit breaker and cause it to trip or open.

**⚠ CAUTION:** Do not use portable or stationary backup generating equipment to charge the vehicle. This may cause damage to the vehicle's charging system. Only charge the vehicle from utility-supplied power.

## Amperage and Breaker Parameters

### Note:

The Charge Station has been factory set at 30-amp output for a 40-amp circuit. For all other amperages:

1. Remove the domed cap from the current-adjustment selector (positioned just above the reset button on the front of the Charge Station).

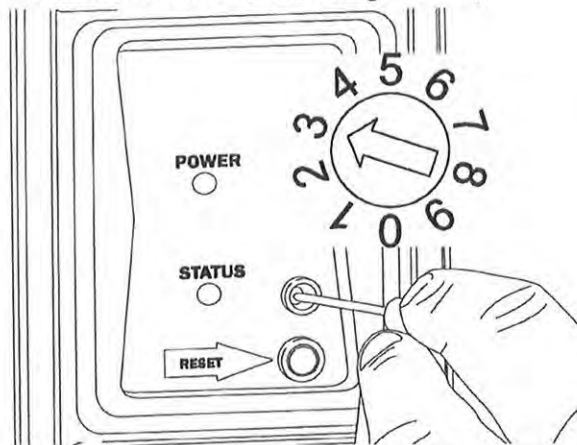

2. Using a small, flat-blade screwdriver, set the current-adjustment selector to the applicable output current-limiting setting, as indicated in Table 1 or Table 2.

**Table 1. North American Current-Adjustment Settings**

Charge Station Current-Adjustment Setting	Charge Station Output, Amp	Breaker Required, Amp	Wire Required, Gauge	NEMA Receptacle Required (plug-in version)
1	12	15	12	6-15
2	16	20	12	6-20
3	24	30	10	6-30
4	32	40	8	6-50
5	30	40	8	6-50

**Table 2. European Current-Adjustment Settings**

Charge Station Current-Adjustment Setting	Charge Station Output, Amp	Breaker Required, Amp	Wire Required, mm <sup>2</sup>
1	13	16	3.31
2	16	20	3.31
3	20	20*	5.26
4	32	40	8.36
5	30	40	8.36

\*Line service breaker; not appliance service breaker

### Note:

Only settings 1–5 are operational. Settings 6, 7, 8, 9, and 0 are not used, and the Charge Station will not function under these settings.

## Charge Station Mounting Instructions

**⚠ WARNING:** Read all instructions before installing the Charge Station.

Identify an approximate mounting location for the Charge Station that is within 10 feet (3 m) of the vehicle's charging inlet.

Determine the power source location.

**⚠ CAUTION:** Verify there is no existing infrastructure behind the selected wall (wiring, plumbing, ductwork, pipes, etc.)

Follow the appropriate instructions for your installation:

- "Finished Wall Charge Station Installation" on page 9
- "Masonry Wall Charge Station Installation" on page 13
- "Molded Plug-Connected Charge Station Installation (North America only)" on page 16

### Note:

If wall surface is unfinished (studs only), mount a 36 × 17.5 × 3/8-in. (90 × 45 × 1-cm) plywood surface between the studs and securely fasten in place. Follow "Finished Wall Charge Station Installation" for mounting and "Masonry Wall Charge Station Installation" for wiring.

## Mounting Template

See the back cover of this manual for the Charge Station mounting template.

## Finished Wall Charge Station Installation



1. Using a stud finder and tape measure, locate and mark a point equidistant between vertical studs and 45 in. (114.3 cm) above the floor surface.

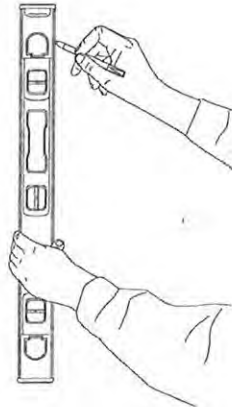

2. From this point, use a level to draw a true vertical line and a true horizontal line on the wall.
3. Retrieve the mounting template on the back cover of this manual.

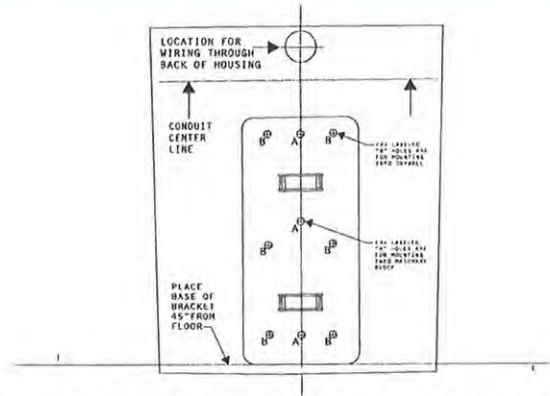

4. Align the hash-marked center and lower horizontal lines of the template to the lines drawn on the wall. Adhere the template to the wall with tape.

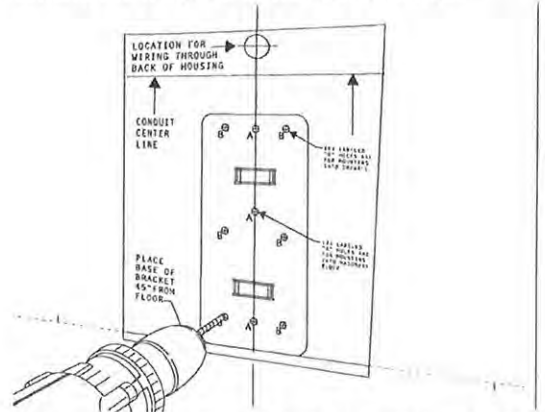

5. Using a 3/16-in. (5-mm) drill bit, drill the six (6) holes marked „B“ on the template.

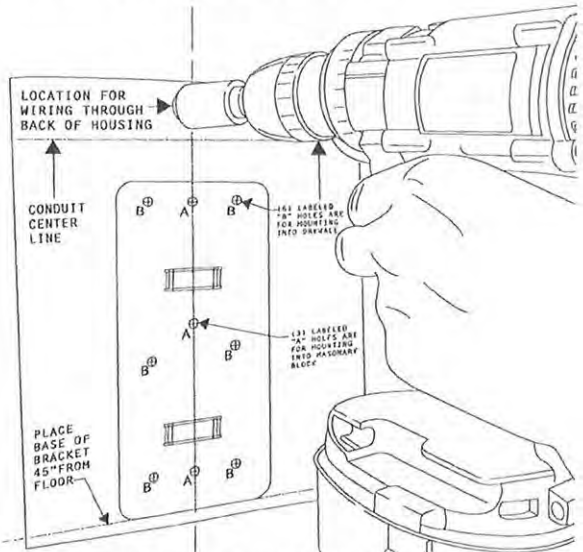

6. Using a 1 1/16-in. (28-mm) hole saw, drill a wiring-access hole at the location indicated at the top of the template.

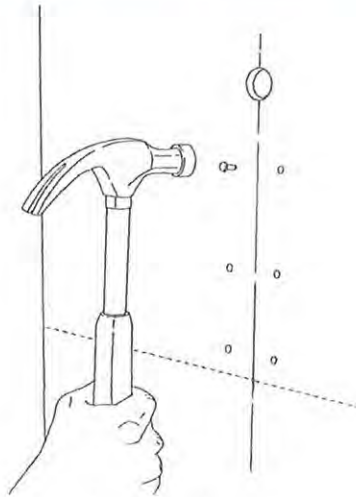

7. Remove the template from the wall. Using a hammer, install a plastic drywall anchor in each of the six (6) „B“ holes.

**Note:**

Charge Station support-strength requirement is based on a minimum 3/8-in. (1-cm) drywall thickness

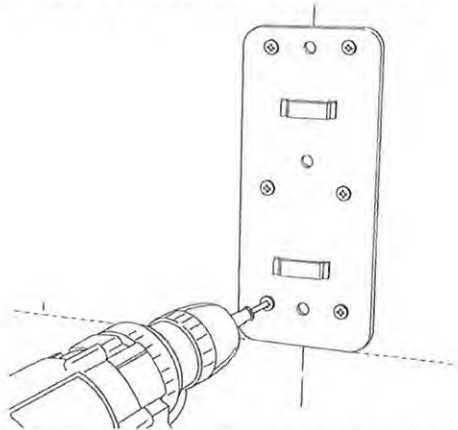

8. Align mounting plate with installed plastic anchors and secure with six (6) #8 pan-head screws.

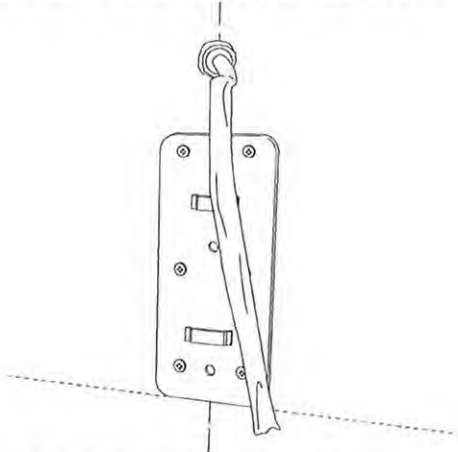

9. Feed sufficient wire from the service panel through the wire-access hole to make connections to the Charge Station terminal block.

**Note:**

To avoid damage to the front of the Charge Station, place it on a soft or cardboard surface.

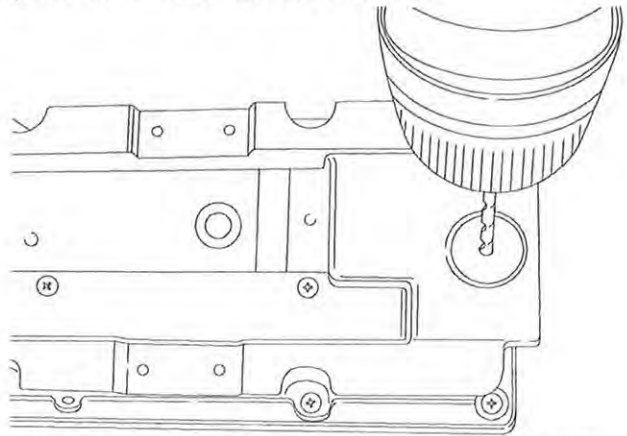

10. Drill a pilot hole in the center of the rear knockout on the Charge Station unit.

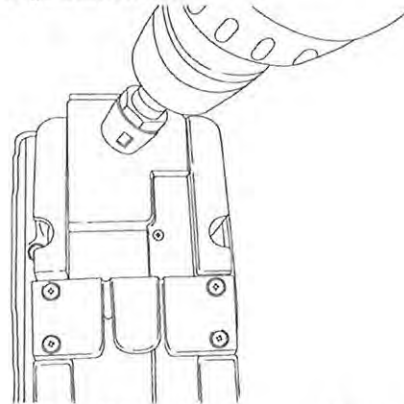

11. Using a 1 1/16-in. (28-mm) hole saw, with the pilot hole as a guide, drill out the rear knockout.

**⚠ CAUTION:** Use a mid-range speed setting and drill carefully to avoid punching through housing and damaging internal components.

12. Remove debris from wiring chamber.

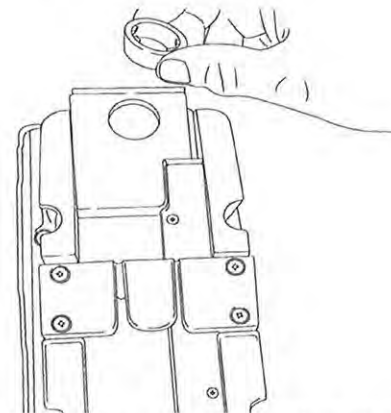

13. **For indoor installation,** assemble the plastic hole-bushing into the knockout and firmly snap into place.

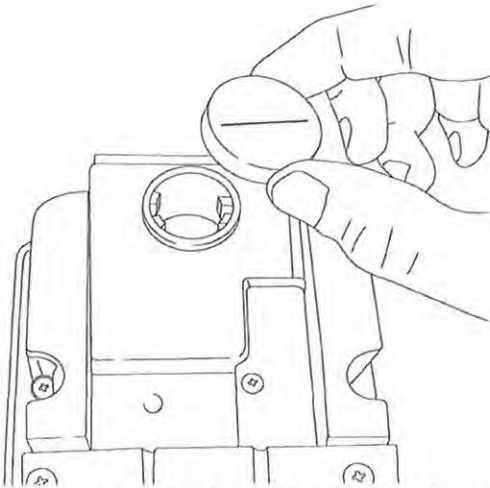

14. Cover the plastic bushing with the self-adhesive foam dust-cover gasket, with the center-slit oriented horizontally.

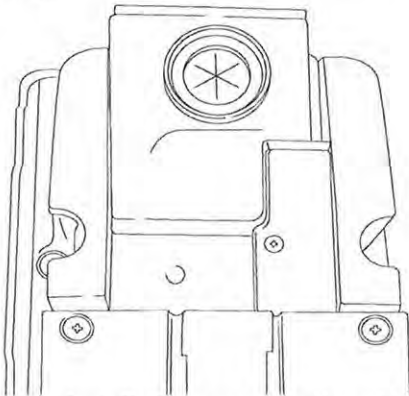

15. **For outdoor installation**, assemble the rubber grommet into the knockout and snap into place.  
 16. Feed the wire from the service panel, through the dust cover or grommet, and into the Charge Station wiring chamber.

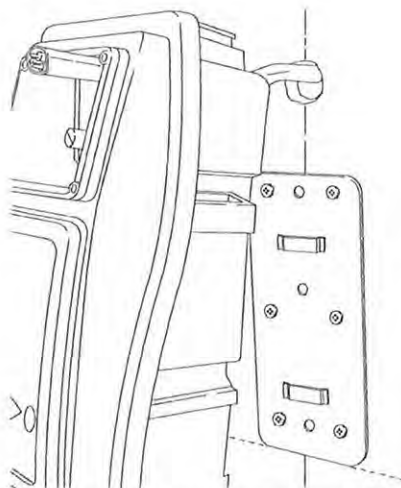

17. Secure the Charge Station to the mounted wall bracket by engaging the tabs on the Charge Station into the slots on the wall bracket. Press firmly and slide the Charge Station down until fully seated on the bracket.

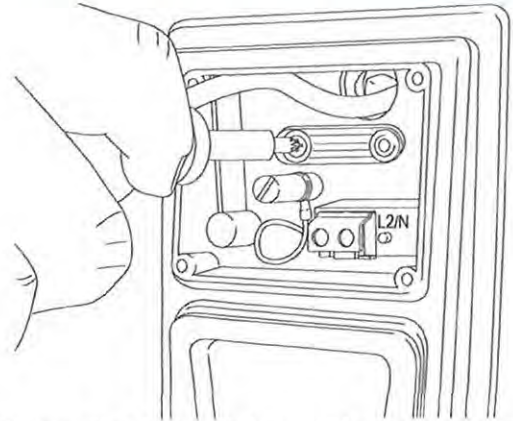

18. Remove the strain-relief assembly from the wiring chamber.

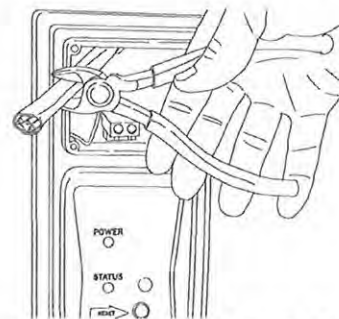

19. Trim the wire to a length sufficient to make the connections to the Charge Station terminal block.

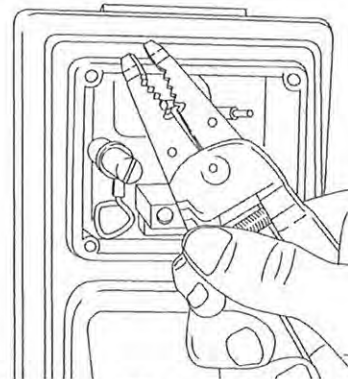

20. Strip back 1 1/4 in. (32 mm) of the wire jacket and 3/8 in. (10 mm) from the ends of the individual conductors.

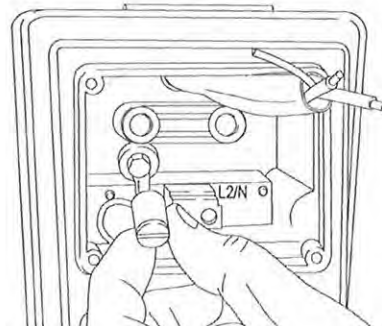

21. Remove threaded ground lug.

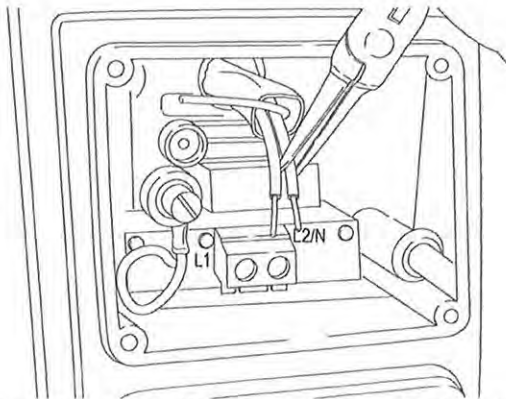

22. Feed the L1 (black) [Europe H (brown)] wire into the L1 [Europe H] terminal slot in the wiring chamber.
23. Feed the L2 (red) [Europe N (blue)] wire into the L2 [Europe N] terminal slot in the wiring chamber.
24. Attach safety ground wire through the slot on the ground terminal. Hand-tighten grounding lug.

**Note:**

See inside of wiring chamber cover for wiring schematic.

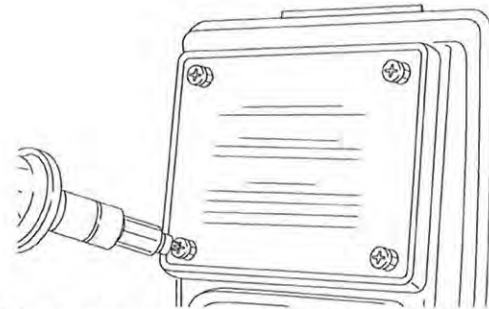

27. Attach the wiring chamber lid with four (4) 3/4-in. (20-mm) square-drive screws.
28. Apply the self-adhesive chamber lid label.

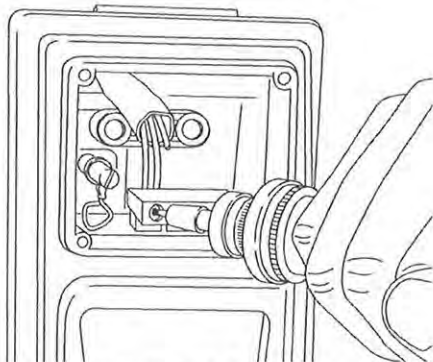

25. Tighten terminal screws to 1.2 Nm (10.62 in-lb).

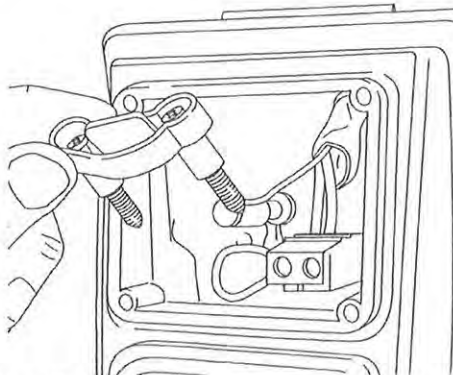

26. Reinstall strain relief.

**Note:**

Select appropriate orientation of insert to achieve proper clamping for wire size used.

**⚠ CAUTION:** Do not overtighten.

## Masonry Wall Charge Station Installation

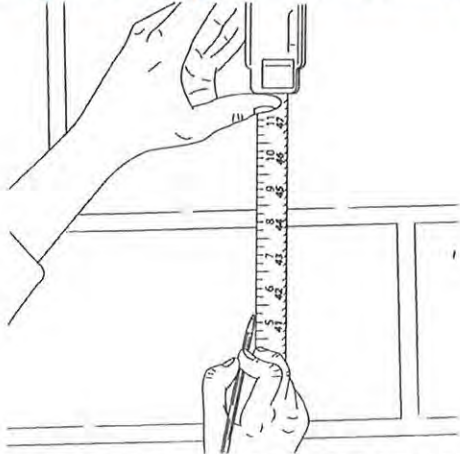

1. Locate and mark a point 45 in. (114.3 cm) above the floor surface.

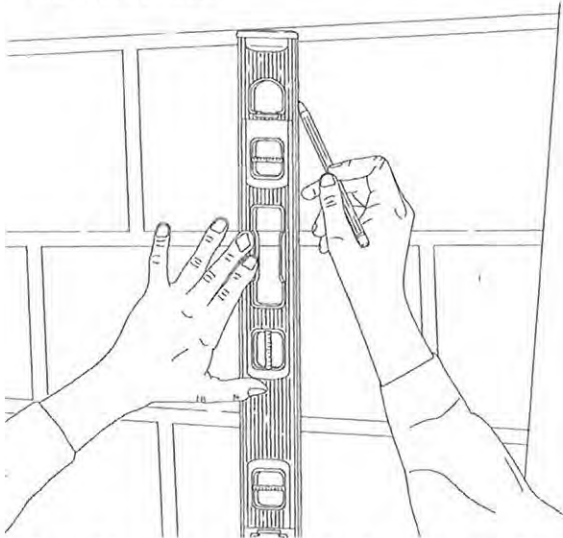

2. From this point, use a level to draw a true vertical line and a true horizontal line on the wall.
3. Retrieve the mounting template on the back cover of this manual.

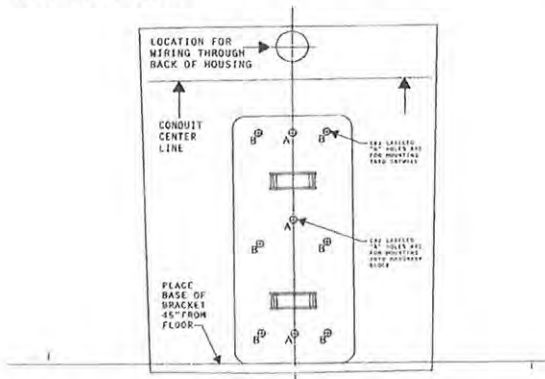

4. Align the hash-marked center and lower horizontal lines of the template to the lines drawn on the wall. Adhere the template to the wall with tape.

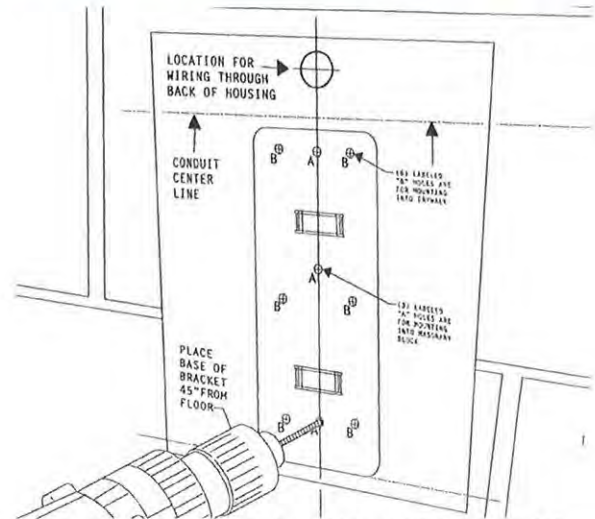

5. Using a 1/8-in. (3-mm) drill bit, drill the three (3) holes marked „A“ on the template.
6. Select a location on the template for entry of conduit into the Charge Station (top, upper left, or upper right).

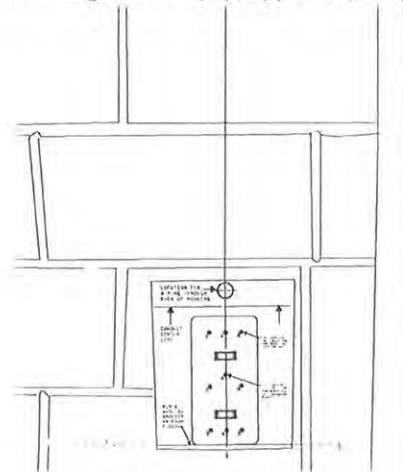

7. Snap a chalk line from the appropriate level line on the template in the direction of the incoming conduit.
8. Remove the template from the wall.

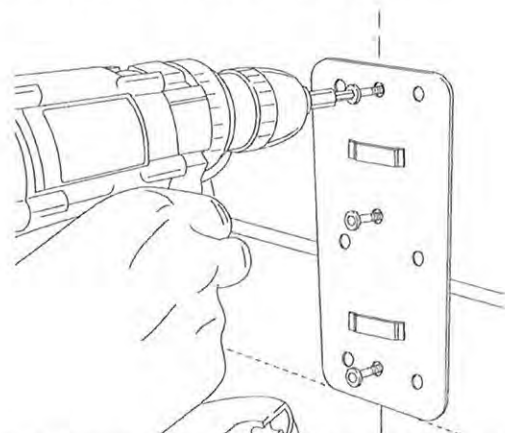

9. Align the mounting plate with the „A“ holes in the wall and secure with three (3) 3/16-in. (5-mm) tapered-head masonry screws.

**Note:**

To avoid damage to the Charge Station, place it on a soft or cardboard surface.

10. Locate the desired conduit-entry point on the Charge Station housing.

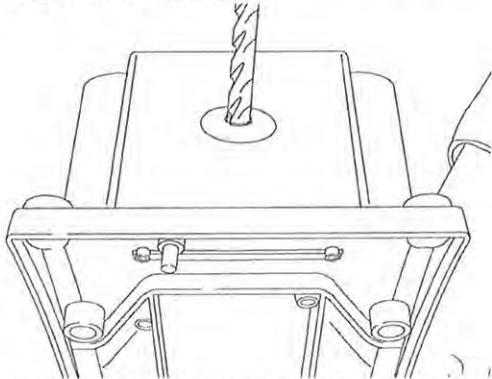

11. Drill a pilot hole in the center of the selected knock-out location.

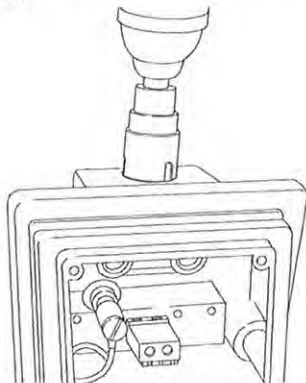

12. Using a 1 1/16-in. (28-mm) hole saw, with the pilot hole as a guide, drill out the knockout.

**⚠ CAUTION:** Use a mid-range speed setting and drill carefully to avoid punching through housing and damaging internal components.

13. Remove debris from wiring chamber.

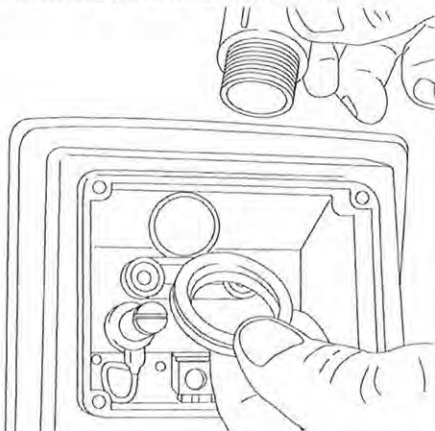

14. Install a 3/4-in. (19-mm) NPT female adaptor with nut and seal into the knockout and tighten securely.

15. Secure the Charge Station to the mounted wall bracket by engaging the tabs on the Charge Station into the slots on the wall bracket. Press firmly and slide the Charge Station down until fully seated on the bracket.
16. Feed the wire from the service panel through the conduit and into the Charge Station wiring chamber.

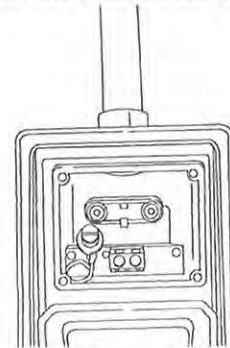

17. Attach offset conduit to NPT female adaptor.

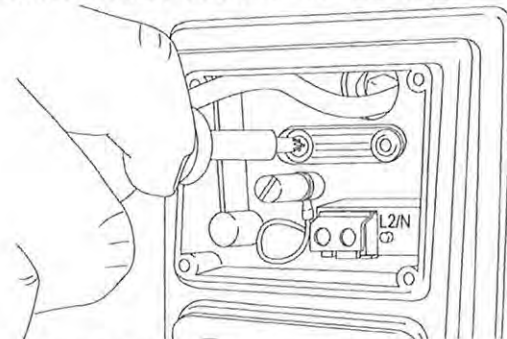

18. Remove the strain-relief assembly from the wiring chamber.

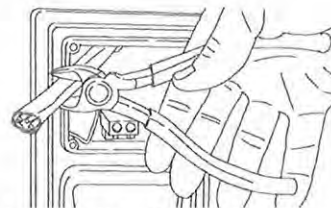

19. Trim the wire to a length sufficient to make the connections to the Charge Station terminal block.

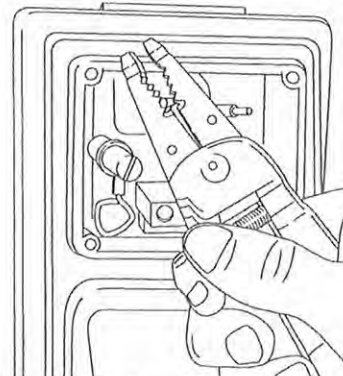

20. Strip back 1 1/4 in. (32 mm) of the wire jacket and 3/8 in. (10 mm) from the ends of the individual conductors.

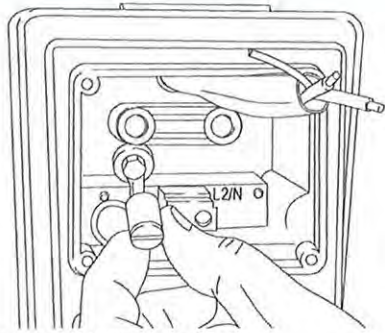

21. Remove threaded ground lug.

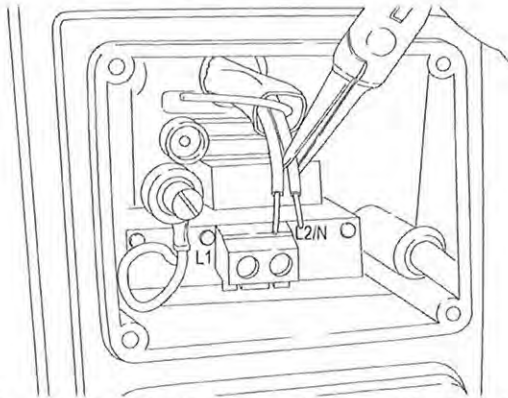

22. Feed the L1 (black) [Europe H (brown)] wire into the L1 [Europe H] terminal slot in the wiring chamber.  
 23. Feed the L2 (red) [Europe N (blue)] wire into the L2 [Europe N] terminal slot in the wiring chamber.

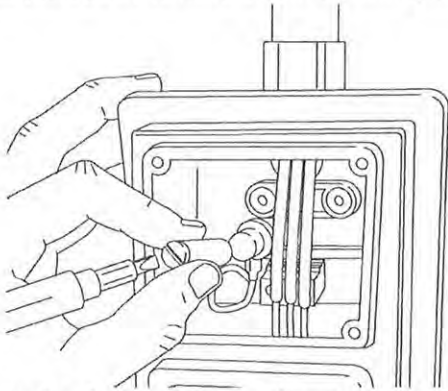

24. Attach safety ground wire through the slot on the ground terminal. Hand-tighten grounding lug.

**Note:**

See inside of wiring chamber cover for wiring schematic.

25. Tighten terminal screws to 1.2 Nm (10.62 in-lb).

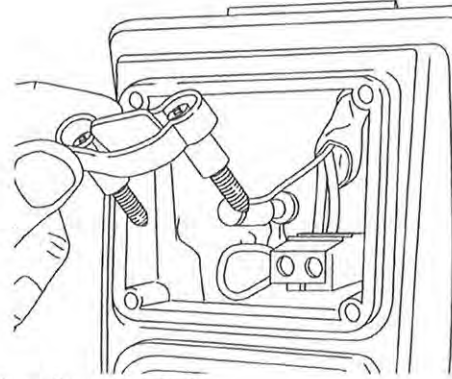

26. Reinstall strain relief.

**Note:**

Select appropriate orientation of insert to achieve proper clamping for wire size used.

⚠ CAUTION: Do not overtighten.

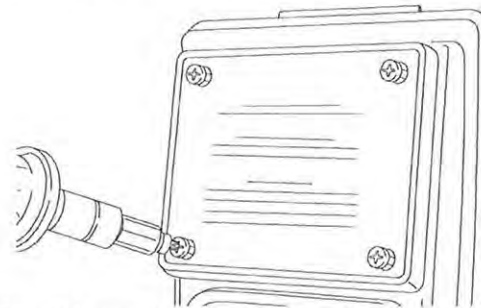

27. Attach the wiring chamber lid with four (4) 3/4-in. (20-mm) square-drive screws.

28. Apply the self-adhesive chamber lid label.

## Molded Plug-Connected Charge Station Installation (North America only)

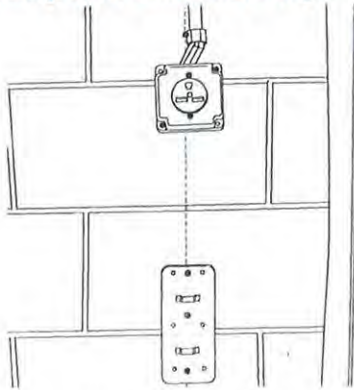

1. Install appropriate outlet box (ground-pin at 12-o'clock position) with top- or side-conduit feed.
- ⚠ **CAUTION:** Do not feed the outlet box from the bottom. This will interfere with the mounting of the Charge Station unit.
2. Place the outlet box between two (2) studs for finished-wall installation or any applicable location for masonry walls.
3. Install outlet box 61 in. (155 cm) from floor surface to the bottom of the outlet box.

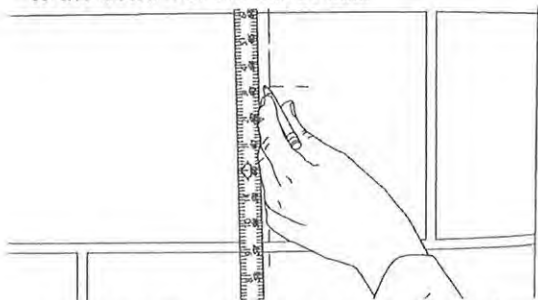

4. Locate and mark a point 16 in. (40.6 cm) down from the bottom-center of the outlet box.

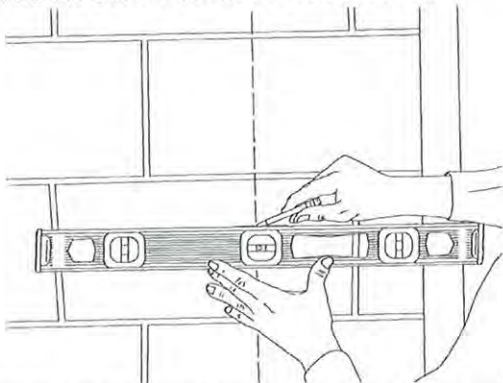

5. From this point, use a level to draw a true vertical line and a true horizontal line on the wall.
6. Retrieve the mounting template on the back cover of this manual.

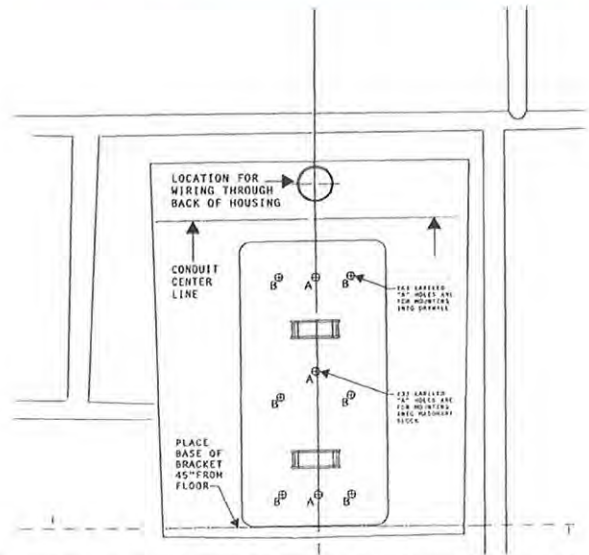

7. Align the hash-marked center and lower horizontal lines of the template to the lines drawn on the wall. Adhere the template to the wall with tape.
8. If installing on a masonry wall, using a 1/8-in. (3-mm) drill bit, drill the three (3) holes marked „A“ on the template.
9. If installing on a finished wall, using a 3/16-in. (5-mm) drill bit, drill the six (6) holes marked „B“ on the template.
10. Remove the template from the wall.
11. Align the mounting plate with the holes in the wall and secure with three (3) 3/16-in. (5-mm) tapered-head masonry screws for masonry walls or six (6) #8 pan-head screws with anchors for finished walls.

### Note:

To avoid damage to the Charge Station, place it on a soft or cardboard surface.

12. Locate the desired conduit-entry point on the Charge Station housing.

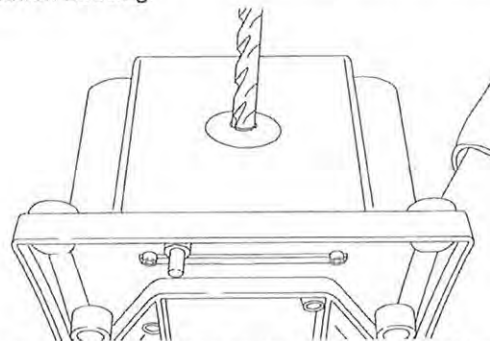

13. Drill a pilot hole in the center of the selected knock-out location.

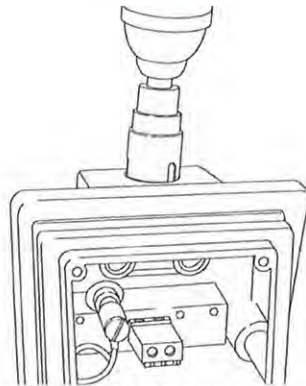

14. Using a 1 1/16-in. (28-mm) hole saw, with the pilot hole as a guide, drill out the knockout.

⚠ **CAUTION:** Use a mid-range speed setting and drill carefully to avoid punching through housing and damaging internal components.

15. Remove debris from wiring chamber.

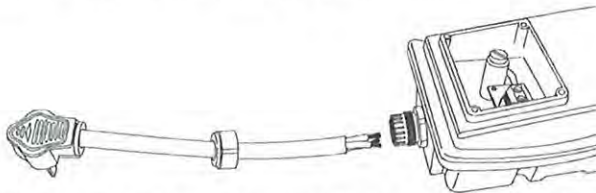

16. Install the 3/4-in. (19-mm) cable gland adaptor with nut and O-ring into drilled 1 1/16-in. (28-mm) hole in the Charge Station. Securely tighten.  
17. Assemble the 3/4-in. (19-mm) cable gland cap to the molded plug/cable assembly.

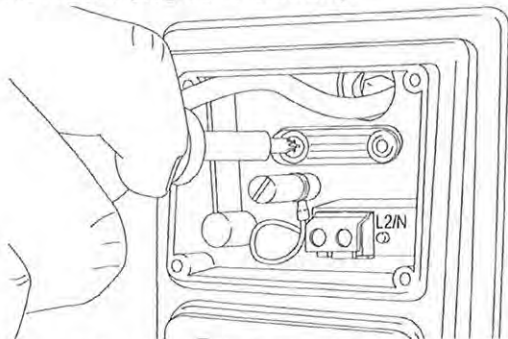

18. Remove the strain-relief assembly from the wiring chamber.

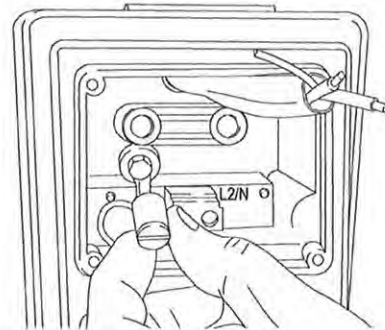

19. Remove threaded ground lug.

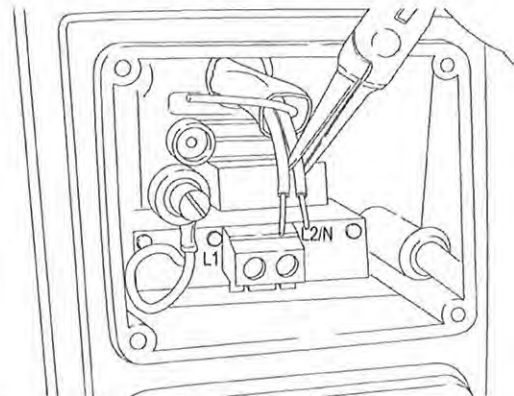

20. Feed molded plug/cable/cable gland assembly through the 1 1/16-in. (28-mm) hole in the housing and orient the conductor wire to the terminal block. Remove strip/retain insulation ends.

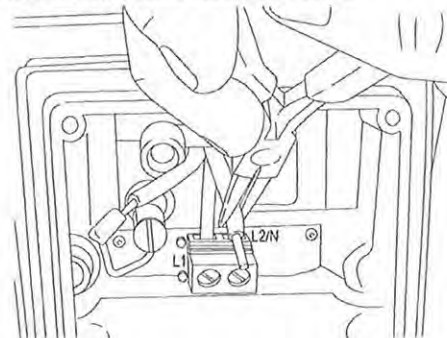

21. Feed the L1 (black) [Europe H (brown)] wire into the L1 [Europe H] terminal slot in the wiring chamber.  
22. Feed the L2 (red) wire into the L2 terminal slot in the wiring chamber.  
23. Attach safety ground wire through the slot on the ground terminal. Hand-tighten grounding lug.

**Note:**

See inside of wiring chamber cover for wiring schematic.

24. Tighten terminal screws to 1.2 Nm (10.62 in-lb).

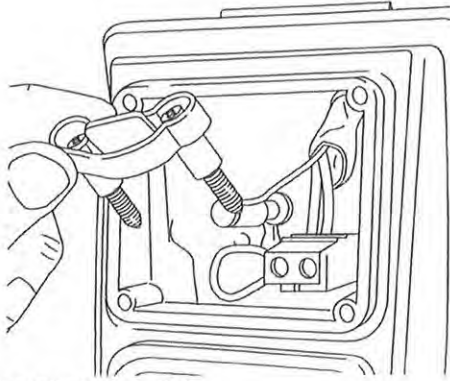

25. Reinstall strain relief.

**Note:**

Select appropriate orientation of insert to achieve proper clamping.

⚠ CAUTION: Do not overtighten.

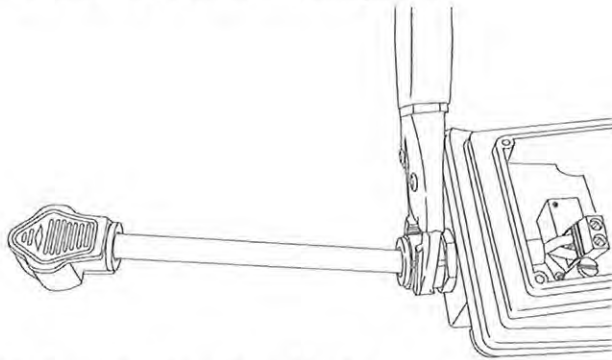

26. Securely tighten the cable gland.

27. Secure the Charge Station to the mounted wall bracket by engaging the tabs on the Charge Station into the slots on the wall bracket. Press firmly and slide the Charge Station down until fully seated on the bracket.

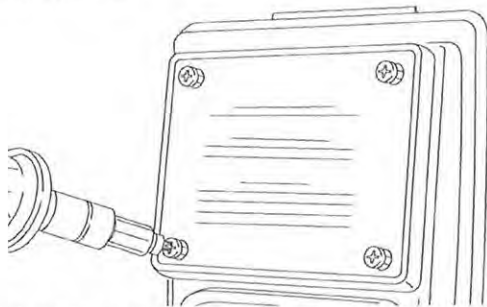

28. Attach the wiring chamber lid with four (4) 3/4-in. (20-mm) square-drive screws.

29. Apply the self-adhesive chamber lid label.

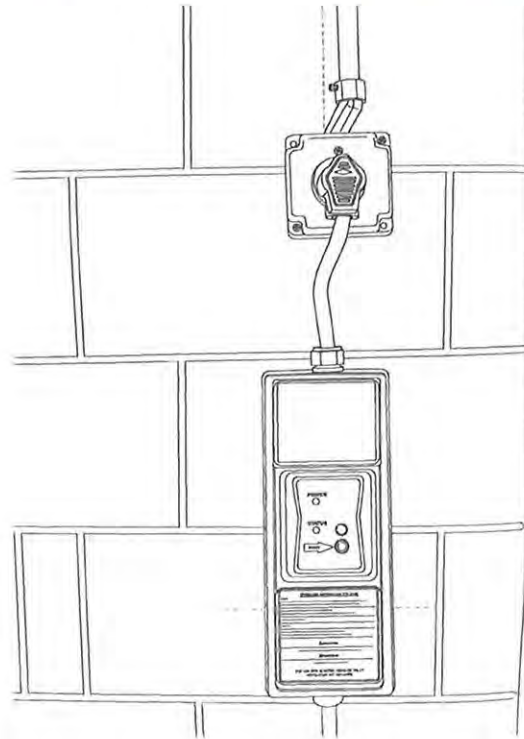

30. Plug Charge Station plug into NEMA outlet.



















## Operating Instructions

1. Verify service supply power is available; green POWER indicator LED is illuminated.
2. Retrieve Charge Station vehicle cable and coupler from rear-mounted holder (stowed position); amber STATUS indicator light is illuminated.
3. Connect Charge Station coupler to vehicle; STATUS indicator LED changes to solid green.
4. Charge Station performs safety self-test (audible mechanical clicking sounds); STATUS indicator begins to flash green, indicating vehicle is charging (vehicle may indicate charging with an audible signal or a light indicator; varies by vehicle model). When charge is complete, the STATUS LED will change from flashing green to solid green.
5. Disconnect Charge Station coupler from vehicle; STATUS indicator changes to amber.
6. Return cable and coupler to rear-mounted holder (stowed position) at Charge Station unit.



**Note:**

Charge Station will automatically resume charging upon restoration of lost service-supply power (US models only).

## Power and Status LED Indications

Power LED	Status LED	Condition
(Off) 	(Off) 	No service supply power
Green solid 	Amber solid 	Charge Station powered; vehicle coupler not connected
Green solid 	Green solid 	Waiting to charge
Green solid 	Green flashing 	Vehicle charging
Green solid 	1-2 red flashes every 2 seconds 	Pilot charging error*
Green solid 	Solid red, then green flash every 2 seconds 	Ground fault detected*
Green solid 	Red flashing 	Ground monitor interrupted*
Green solid 	Red solid 	Operation fault*
Green solid 	(Off) 	Operation fault*

\*See "Troubleshooting" on page 20 for suggested solutions.

-  - No illumination
-  - Solid illumination
-  - Flashing illumination

## Troubleshooting

If there is a charging issue proceed with the following steps. If the issue persists after three attempts call Bosch at 1-877-805-EVSE (3873) for assistance.

Problem Indicated by LED Status	Solution
Pilot charging error	<ol style="list-style-type: none"> <li>1. Verify supply-side power. The green POWER LED should be on. If green POWER LED is off, locate load center/panel and reset breaker.</li> <li>2. Press the master clear RESET button on the front panel of the Charge Station to attempt a charge-restart.</li> <li>3. If the red STATUS LED remains on, disconnect the Charge Station coupler from the vehicle charge port, wait 10 seconds, and reconnect the coupler.</li> </ol>
Ground fault detected	<ol style="list-style-type: none"> <li>1. Disconnect main service power at service panel.</li> <li>2. Disconnect the Charge Station coupler from the vehicle.</li> <li>3. Inspect the Charge Station connector and the vehicle charge port verifying both are clean and undamaged. If vehicle charge port needs cleaning, follow manufacturer instructions for cleaning. Clean Charge Station connector with a dry or damp cloth if necessary.</li> <li>4. Restore main service power.</li> <li>5. Reconnect the coupler to the vehicle port.</li> </ol>
Ground monitor interrupted	<ol style="list-style-type: none"> <li>1. Disconnect main service power at service panel.</li> <li>2. Disconnect the Charge Station coupler from the vehicle.</li> <li>3. Inspect the Charge Station connector and the vehicle charge port verifying both are clean and undamaged. If vehicle charge port needs cleaning, follow manufacturer instructions for cleaning. Clean Charge Station connector with a dry or damp cloth if necessary.</li> <li>4. Restore main service power.</li> <li>5. Reconnect the coupler to the vehicle port.</li> </ol>

Problem Indicated by LED Status	Solution
Operation fault	<ol style="list-style-type: none"> <li>1. Verify supply-side power. The green POWER LED should be on. If green POWER LED is off, locate load center/panel and reset breaker.</li> <li>2. Press the master clear RESET button on the front panel of the Charge Station to attempt a charge-restart.</li> <li>3. If the red STATUS LED remains on, disconnect the Charge Station coupler from the vehicle charge port, wait 10 seconds, and reconnect the coupler.</li> </ol>

### Ground Fault Circuit Interrupt (GFCI) Tripped

If the Charge Station detects a ground fault, power will be interrupted and the STATUS LED will illuminate (red flash with intermittent green). The Charge Station will attempt to reset automatically and re-attempt charging (see note below on European models). If the fault condition persists after an initial automatic attempt, per the code, the Charge Station waits 15 minutes before a second attempt is made. A total of four attempts will be made to restore vehicle charging. If the charging mode cannot be restored, the STATUS LED will illuminate solid red, and the unit will stay in fault mode.

**Note:**

European models—Automatic reset feature after ground fault (STATUS LED will be solid red) does not apply to European models. European standards dictate that user intervention is required by pressing the master clear RESET button on the front of the Charge Station housing. If ground fault condition clears, Charge Station will resume charging.

### Missing Ground

If the Charge Station detects a missing ground connection (rapid red flashing LED), power will be interrupted and the unit will not be capable of charging vehicle until a ground connection has been detected. Disconnect service power (breaker) and disconnect vehicle coupler from vehicle and contact a qualified Bosch technician to validate the presence of a proper ground.

## Maintenance

**⚠ WARNING: Do not attempt to service the Charge Station. The Charge Station has no user-serviceable components.**

If the unit is not operating properly, contact Bosch at 1-877-805-EVSE (3873) for assistance.

The Charge Station requires no scheduled maintenance, only periodic cleaning.

Always be sure to return the charging cable and coupler to its proper storage area to avoid potential damage to the unit and to prevent potential trip hazards.

Regularly inspect the Charge Station unit and charging cable for signs of damage. If the Charge Station unit or charging cable are damaged contact Bosch for service or repair.

## Cleaning

**⚠ CAUTION:** Always turn off service power (supply-side power at the main service panel) before cleaning the Charge Station and/or charging cable.

**⚠ CAUTION:** Never use cleaning solvents, abrasive powders/liquids or scouring pads to clean the Charge Station and cable/coupler.

Clean the Charge Station unit and cable/coupler with a soft damp or dry cloth to remove dust or dirt.

## Storage and Moving

Unit storage temperature range: -58°F to +176°F (-50°C to +80°C)

Contact Bosch for Charge Station relocation or storage requirements at 1-877-805-EVSE (3873).

## Limited Warranty

THIS WARRANTY IS EXPRESSLY LIMITED TO THE ORIGINAL PURCHASER OF Bosch Automotive Service Solutions LLC Charge Station product.

Power Xpress Charge Station is warranted against defects in materials and workmanship for one year from the date of installation.

Charge Station Cables and Connectors are warranted against defects in materials and workmanship for 90 days from the date of delivery.

This warranty is only valid to the original purchaser of the Charge Station and is not transferable. All warranty claims must be made within the warranty period and proof of purchase must be supplied. This warranty does not cover the cost of freight to return the Charge Station to Bosch Automotive Service Solutions LLC.

The sole and exclusive remedy for any Charge Station found to be defective is repair or replacement, at the option of Bosch Automotive Service Solutions LLC. The existence of a defect shall be determined by Bosch Automotive Service Solutions LLC in accordance with procedures established by Bosch Automotive Service Solutions LLC. No one is authorized to make any statement or representation altering the terms of this warranty. This warranty covers only those defects that arise as a result of normal use of the Charge Station and does not cover any other problems including those that arise as a result of abuse, neglect, improper maintenance, care or modification, operation outside of the Charge Station's specifications or in a manner inconsistent with instructions regarding use. Bosch Automotive Service Solutions LLC does not make any representation or warranty regarding the continuous availability of electrical service to the Charge Station.

This warranty gives the original purchaser specific legal rights. The original purchaser may also have other rights which vary from state to state. To the extent that this warranty is inconsistent with applicable law, this warranty will be deemed modified to be consistent with such local law.

## Disclaimer

TO THE EXTENT PERMITTED BY APPLICABLE LAW AND EXCEPT AS EXPRESSLY PROVIDED IN THE LIMITED WARRANTY, Bosch Automotive Service Solutions LLC MAKES NO WARRANTY WITH RESPECT TO THE EQUIPMENT OR THE SERVICES, WHETHER EXPRESS, IMPLIED, STATUTORY OR OTHERWISE. Bosch Automotive Service Solutions LLC EXPRESSLY DISCLAIMS ALL OTHER WARRANTIES, INCLUDING, BUT NOT LIMITED TO, THE IMPLIED WARRANTIES OF NON-INFRINGEMENT OF THIRD PARTY RIGHTS, MERCHANTABILITY AND FITNESS FOR A PARTICULAR PURPOSE. Bosch Automotive Service Solutions LLC DOES NOT WARRANT UNINTERRUPTED OR ERROR FREE OPERATION OF THE EQUIPMENT.

The Charge Station should be installed only by a licensed electrician and in accordance with all local and national codes and standards.

All information, illustrations, and specifications contained in this installation guide are based on the latest information available at the time of publication. The right is reserved to make changes at any time without obligation to notify any person or organization of such revisions or changes. Further, this Guide is provided "as is" and Bosch Automotive Service Solutions LLC shall not be liable for errors contained herein.

## Legal Limitation of Liability

TO THE EXTENT ALLOWED BY APPLICABLE LAW, IN NO EVENT SHALL Bosch Automotive Service Solutions LLC OR ITS SUPPLIERS BE LIABLE FOR DIRECT, INDIRECT, SPECIAL, INCIDENTAL OR CONSEQUENTIAL DAMAGES, WHETHER BASED ON CONTRACT, TORT, OR ANY OTHER LEGAL THEORY AND WHETHER ADVISED OF THE POSSIBILITY OF SUCH DAMAGES.

Some states do not allow the exclusion or limitation of incidental damages for some products, so the limitations or exclusions contained herein may not apply.

## Copyrights, Trademarks

No part of this guide may be reproduced, stored in a retrieval system, or transmitted, in any form or by any means, electronic, mechanical, photocopying, recording, or otherwise, without the prior written permission of Bosch Automotive Service Solutions LLC. Bosch Automotive Service Solutions LLC is a registered trademark of Bosch Automotive Service Solutions LLC. All third party trademarks are the property of their respective owners.

LOCATION FOR  
WIRING THROUGH  
BACK OF HOUSING

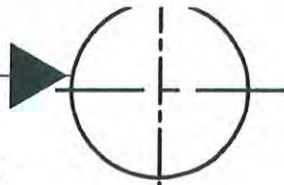

CONDUIT  
CENTER  
LINE

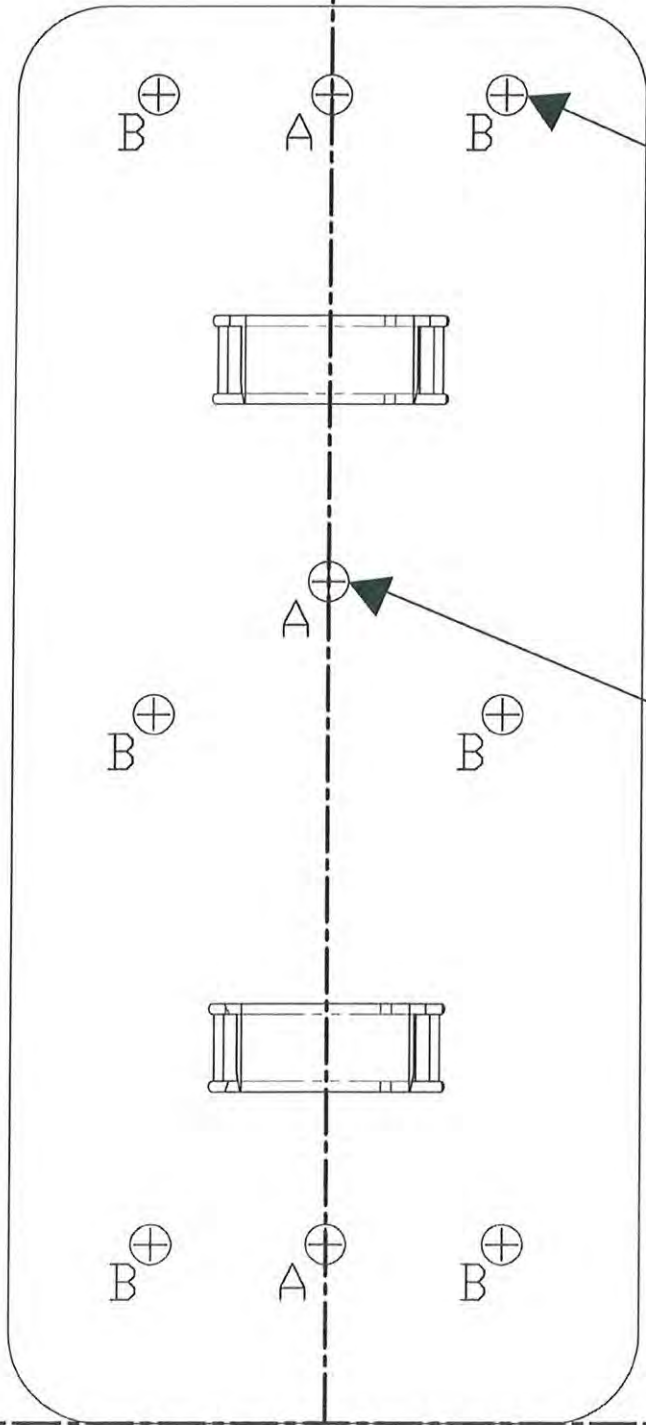

(6) LABELED  
"B" HOLES ARE  
FOR MOUNTING  
INTO DRYWALL

(3) LABELED  
"A" HOLES ARE  
FOR MOUNTING  
INTO MASONARY  
BLOCK

PLACE  
BASE OF  
BRACKET  
45" FROM  
FLOOR





**Bosch**  
Automotive Service Solutions LLC



W  n







# Level 2 EVSE

## Base Features

- Ground Fault Circuit Interrupter
- Ground Assurance Circuitry
- Auto Test & Reset
- Charge Current Limit Setting
- Expanded Functionality / UART port
- Exceeds NEMA 4X Wet Location Rating
- Encapsulated Circuits for Harsh Environment
- Multiple color LED's
- De-energized Cable upon strain
- Master Reset
- Complete Plastic Enclosure, nonconducting
- Finger Safe Field Wiring Blocks – Line side and Secondary side
- Standards driven design



## Technical Specifications

- Amperage ..... 32Amax (Field Adjustable)
- Voltage..... 95 VAC – 264 VAC
- Frequency ..... 50/60 Hz
- Ground Fault Trip Level ..... 17.5 mA (20mA Max)
- Ground Assurance..... 50K ohm Max
- Operating Temperature ..... -35°C to +66°C
- Storage Temperature ..... -40°C to +85°C
- Ground Fault Test..... Automatic at start-up (Firmware controlled)
- Ground Fault Retry..... 4 retries @15 min. intervals (per UL 2594/UL 2231)
- Master Clear ..... For System Reset (Overrides Ground Fault Retry)
- Power Indication..... Green LED
- Charge Status Indicators ..... Amber (Ready), Green (Plugged In), Green Flash (Charging) , Red Flash (Fault State)

# Level 2 EVSE

## Standard Compliances

### North America Operation

- UL 2594 ..... Electric Vehicle Supply Equipment
- UL 2251 ..... Plugs, Receptacles and Couplers for Electric Vehicles
- UL 1998 ..... Firmware Operation - Software in Programmable Components
- SAE J1772 ..... EV & PEV Hybrid Electric Vehicle Conductive Charge Coupler
- FCC Part 15..... EMI/RFI Subpart B Compliant

### Safety

- Safety Device ..... CCID20 with Ground Assurance
- NEC Article 625..... Electric Vehicle Supply Equipment
- UL 2231-1 & -2 ..... Personnel Protection Systems for Electric Vehicle (EV)  
Supply Circuits: General Requirements
- UL 62 ..... Standard for Safety of Flexible Cord

### European Union Operation

- IEC 61851-1
- IEC 61851-21 & 22
- IEC 62196 Coupler, Type 1, Type 2
- IEC 62196 Plug, Type 2, Type 3
- IEC 61000-4-2, Electrostatic Discharge
- IEC 60204-1, safety for servicing electronic equipment

## Detailed Features

- Ingress Protection .....NEMA 4X (IP 66) CCID entirely potted
- Sealing .....Weather Tight I/O glands
- Smart Charging.....Peripheral Control Expandable via Opto Coupled  
UART Interface (for EMS, HAN, etc. controller)
- Service Wire Chamber.....Inputs: left, right, top & back
- Field Wireable .....Service Side to NEC 312.6 and NEC 314.16
- Plug and Play.....Via NEMA Rated Power side Plug & Outlet
- Vehicle Cable/Coupler .....Field Service Replaceable
- Firmware Upgrades.....Field Reprogrammed
- Diagnostic Trouble Codes .....Field Accessible
- Mounting .....Via Slide Mounting to wall bracket
- Assembly.....UL, CE, CSA, ROHS, WEEE compliant
- Housing Material .....ABS-FR (fire retardant)
- EVSE Size .....5"wide x 14"high x 4"deep
- EVSE Weight.....CCID, Cable, Coupler ~ 16 lbs

**SPX**

Leading the HOME CHARGING evolution

28635 MOUND RD. • WARREN, MI 48092 • 1-877-805-EVSE (3873)

[www.evse.spx.com](http://www.evse.spx.com) • [www.homecharging.spx.com](http://www.homecharging.spx.com)

PE14-01 BOSCHI073



# SPX

# POWER XPRESS

## Level 2 EVSE

### Base Features

- Approved in Removeable (plug and cord connected) and Permanent (hardwired) Configurations
- Ground Fault Circuit Interrupter
- Ground Assurance Circuitry
- Auto Test & Reset
- Charge Current Limit Setting
- Expanded Functionality / UART port
- Exceeds NEMA 4X Wet Location Rating
- Encapsulated Circuits for Harsh Environment
- Multiple color LED Status Indicators
- Master Reset
- Complete Plastic Enclosure, nonconducting
- Finger Safe Field Wiring Blocks – Line side and Secondary side
- Standards driven design



Part No. EL-50600



### Technical Specifications

- Amperage .....24A\*
- Voltage.....95 VAC – 264 VAC
- Frequency .....50/60 Hz
- Ground Fault Trip Level .....17.5 mA (20mA Max)
- Ground Assurance .....50K ohm Max
- Operating Temperature.....-35°C to +66°C (-30°F to +150°F)
- Storage Temperature.....-40°C to +85°C (-40°F to +185°F)
- Ground Fault Test..... Automatic at start-up (Firmware controlled)
- Ground Fault Retry..... 4 retries @15 min. intervals (per UL 2594/UL 2231)
- Master Clear..... For System Reset (Overrides Ground Fault Retry)
- Power Indication..... Green LED
- Charge Status Indicators ..... Amber (Ready), Green (Plugged In), Green Flash (Charging) , Red Flash (Fault State)

\*Field adjustable 12-32A, 32A setting requires cable, connector, and plug assembly upgrade. \*\*Cable holder not included.

PE14-011BOSCH1075

# Level 2 EVSE

## Standard Compliances

### North America Operation

- UL 2594 ..... Electric Vehicle Supply Equipment
- UL 2251 ..... Plugs, Receptacles and Couplers for Electric Vehicles
- UL 1998 ..... Firmware Operation - Software in Programmable Components
- SAE J1772 ..... EV & PEV Hybrid Electric Vehicle Conductive Charge Coupler
- FCC Part 15 ..... EMI/RFI Subpart B Compliant

### Safety

- Safety Device ..... CCID20 with Ground Assurance
- NEC Article 625 ..... Electric Vehicle Supply Equipment
- UL 2231-1 & -2 ..... Personnel Protection Systems for Electric Vehicle (EV) Supply Circuits: General Requirements
- UL 62 ..... Standard for Safety of Flexible Cord

### European Union Operation

- IEC 61851-1
- IEC 61851-21 & 22
- IEC 62196 Coupler, Type 1, Type 2
- IEC 62196 Plug, Type 2, Type 3
- IEC 61000-4-2, Electrostatic Discharge
- IEC 60204-1, safety for servicing electronic equipment

## Detailed Features

- Ingress Protection ..... NEMA 4X (IP 66) CCID entirely potted
- Sealing ..... Weather Tight I/O glands
- Smart Charging ..... Peripheral Control Expandable via UART Interface (for EMS, HAN, etc. controller)
- Service Wire Chamber ..... Inputs: left, right, top & back
- Field Wireable ..... Service Side to NEC 312.6 and NEC 314.16
- Vehicle Cable/Coupler ..... Field Service Replaceable
- Firmware Upgrades ..... Field Reprogrammed
- Diagnostic Trouble Codes ..... Field Accessible
- Mounting ..... Via Slide Mounting to wall bracket
- Assembly ..... UL, CE, CSA, ROHS, WEEE compliant
- Housing Material ..... ABS-FR (fire retardant)
- EVSE Size ..... 5" wide x 14" high x 4" deep
- EVSE Weight ..... CCID, Cable, Coupler ~ 14 lbs



Promotion #  
SS10-283 REV C



# Bosch Statement



**If-Asked Media Statement in response to questions regarding NHTSA and the Bosch Power Xpress 240V battery charging station:**

May 19, 2014

Bosch is working cooperatively with NHTSA as we further examine the matter. This investigation was started based on one customer's report to NHTSA. Since being alerted of the investigation, Bosch has encouraged customers to contact us with any questions or further information. We have received a small number of responses, which we are reviewing. We will continue to review the information received. We can be contacted on the toll-free customer support number – 1-877-805-3873.



Corporate Communications  
Cheryl Kilborn  
[www.boschusa.com](http://www.boschusa.com)

# Bosch Statement



**If-Asked Media Statement in response to questions regarding NHTSA and the Bosch Power Xpress 240V charger:**

April 22, 2014

Bosch is reviewing the filing and will work cooperatively with NHTSA as we further investigate the matter. At this point, Bosch is aware of a singular event reported by a customer. To the extent a customer has any questions or information, Bosch is using its established toll-free customer support number – 1-877-805-3873.

**Contact:**



lations



Corporate Communications  
Cheryl Kilborn  
[www.boschusa.com](http://www.boschusa.com)