

PE14-004

HONDA

3/28/2014

Q6

LABOR OP AND DEFECT
CODES

Labor	Description
723505	retrieve or clear SRS codes w/ diagnostic system
723507	DTC codes for SRS - retrieve codes with SRS light, read data, trouble shoot and clear DTC, initialize SRS
751099	repair SRS unit
751100	replace SRS unit
751107	side airbag left - replace
751108	side airbag right - replace
751199	replace SRS
752199	replace SRS
7521A4	SRS crash (impact) sensor, left front - replace
7521A5	SRS side curtain airbag, left - replace
7521A8	SRS crash (impact) sensor, right front - replace
7521B5	OPDS unit - replace
7521B6	SRS side impact sensor (first), left front - replace
7521B7	SRS side impact sensor (first), right front - replace
7521C1	
7521C2	SRS side curtain airbag, right - replace
7521C3	SRS side impact sensor, left rear - replace
7521C4	SRS side impact sensor, right rear - replace
7521C9	SRS side curtain airbags, both - replace
7521D0	SRS satellite safing sensor - replace
823503	retrieve codes for SRS indicator light, read data, troubleshoot and clear DTC
823505	retrieve SRS codes w/test drive
842100	headliner - replace
842199	headliner - replace
8511C9	seat frame, driver's side - replace
8521B9	seat frame, passenger's side - replace
855185	front shoulder belt buckle, left (1st row) - replace
864175	front shoulder seatbelt/retractor ro retractor/tensioner, right (1st row) - replace

Defect	Category	Sub-category
00201	Broken, Worn, Distorted, Cut, and Deteriorated	Bent
00401	Distorted	
01101	Broken, Worn, Distorted, Cut, and Deteriorated	Permanent set-in fatigue
01801	Broken, Worn, Distorted, Cut, and Deteriorated	Broken
03214	Improper Operation	Erroneous operation
03217	Improper Operation	Not working properly or at all
06401	Short Circuit/Open Circuit	Short circuit
09999	Others	Other

PE14-004

HONDA

3/28/2014

Q7

Class Action Claim Form

UNITED STATES DISTRICT COURT
CENTRAL DISTRICT OF CALIFORNIA

HEATHER GUTIERREZ and CONNIE
KAUPA, on behalf of themselves and all
others similarly situated,

Plaintiffs,

vs.

AMERICAN HONDA MOTOR CO., INC., a
California corporation,

Defendant.

CASE NO: 5:09-cv-01517-JZ-OP

Judge Jack Zouhary

CLAIM FORM

SIDE AIRBAG SETTLEMENT

c/o Class Administrator

P.O. Box 2718

Torrance, CA 90509

**Your Signed Claim Form Must Be Mailed and Postmarked
No Later Than September 2, 2014**

**If You Do Not Submit A Claim Form By September 2,
2014, You Will Not Receive The Benefits Described In The
Class Notice. Please Read This Entire Form Carefully.**

If you experienced a Reimbursable Deployment prior to February 13, 2014, you must fill out this Claim Form to receive the settlement benefits. Members of the Injunctive Class do not need to fill out this Claim Form.

I. ELIGIBILITY AND INSTRUCTIONS

Please read the Class Notice (available at www.SideAirbagSettlement.com) regarding the Settlement carefully before filling out this form. Terms in this Claim Form are defined in the Class Notice and the Settlement Agreement, both of which are available at the Settlement Website.

If you purchased or leased, new or used, one of the following vehicles and you experienced a Reimbursable Deployment while owning or leasing such a vehicle and your vehicle is identified by VIN in the list available on the Settlement Website (see www.SideAirbagSettlement.com), you may be entitled to compensation if you complete and submit this Claim Form in a timely manner: (1) a 2003 Honda Accord Sedan or Coupe with Side Airbags; (2) a 2004 Accord Sedan with Side Airbags manufactured before April 8, 2004; (3) a 2004 Accord Coupe with Side Airbags; or (4) a 2008 Accord Sedan manufactured before June 12, 2008. For a full description of the benefits available under the Settlement and eligibility to claim them, please see Paragraphs 4 and 6 of the Class Notice.

All persons who are members of the Settlement Class and who do not timely request exclusion from the Settlement Class are bound by the terms of the judgment entered by the Court and release their claims against

American Honda Motor Co., Inc. (“AHM”) described in the Class Notice and Settlement Agreement whether or not they submit a Claim Form.

II. TO CLAIM BENEFITS

The benefit to which you may be entitled under the Settlement depends upon whether your Side Airbag has been previously repaired or replaced.

A. IF YOU EXPERIENCED A REIMBURSABLE DEPLOYMENT BUT YOUR SIDE AIRBAG HAS NOT BEEN REPAIRED OR REPLACED

If you experienced a Reimbursable Deployment of a Side Airbag and the Side Airbag has not been repaired or replaced, you are eligible to have AHM repair or replace (at its election) your Side Airbag free of charge. In order to obtain this benefit, you must:

- Fill out the Settlement Class Information (Section III) below;
- Sign the Verification at the end of the Claim Form;
- Return this completed Claim Form, by mail, no later than September 2, 2014; and
- Take your vehicle to an Authorized Honda Dealer in accordance with the instructions in the written acknowledgment of your claim that you will receive from AHM.

B. IF YOU EXPERIENCED A REIMBURSABLE DEPLOYMENT AND INCURRED EXPENSES TO REPAIR OR REPLACE YOUR SIDE AIRBAG

If you experienced a Reimbursable Deployment of a Side Airbag and incurred out-of-pocket expenses to have your vehicle’s Side Airbag repaired or replaced, pursuant to the Settlement, you are eligible for reimbursement of the out-of-pocket expenses that you incurred to replace or repair your vehicle’s Side Airbag. In order to obtain this benefit, you must:

- Fill out the Settlement Class Information (Section III) below;
- Sign the Verification at the end of the Claim Form;
- Submit documentation (in the form of receipts, work orders, repair orders or the like) providing proof of the amount of out-of-pocket expenses claimed, the work performed on your vehicle and who performed that work; and
- Submit documentation of any prior reimbursements or deductions from the out-of-pocket expenses claimed, including but not limited to any amounts paid by insurance, discounts given by the person who performed the work on your vehicle or “goodwill” or other credits from AHM or others; and return the completed Claim Form, by mail, no later than September 2, 2014.

CLAIM FORM FOR SIDE AIRBAG DEPLOYMENT



Name/Address Changes (if any):

Claim #: NNS2- 6000068380

First Name

Last Name

VIN: XXXXXXXXXXXXXXXXXXXX

Address

JOHN DOE

City

State

Zip

1334 STEPHEN COURT

ORANGE, CA 92867

NOTE: you will not be entitled to reimbursement from AHM for any amounts for which you have been previously reimbursed, including but not limited to, prior reimbursements by AHM or through an insurance claim.

III. SETTLEMENT CLASS MEMBER CONTACT INFORMATION

Please provide the information below for all claims so we may contact you if necessary or notify you of status:

Daytime Phone Evening Phone

Cell Phone e-mail

Select One:

I experienced a Reimbursable Deployment of a Side Airbag that has not been repaired or replaced.

I experienced a Reimbursable Deployment and incurred expenses in the amount of \$ to repair or replace the Side Airbag.

If You Are Seeking Reimbursement, Select One:

I have not received any reimbursement of the out-of-pocket expenses I incurred to repair or replace my Side Airbag.

I have received partial reimbursement in the amount of \$ for the out-of-pocket expenses I incurred to repair or replace my Side Airbag.

I have been fully reimbursed for all out-of-pocket expenses I incurred to repair or replace my Side Airbag.

If you are submitting this Claim Form on behalf of another person who is a Settlement Class Member, please explain why you have the authority to do so and attach a copy of any Power of Attorney or other documents that you may have.

NOTE: If there is evidence that abuse or misuse of your vehicle caused the Side Airbag to deploy or that the vehicle otherwise did not experience a Reimbursable Deployment, AHM reserves the right to deny reimbursement, repair or replacement. The process for addressing any disputes regarding the denial of

reimbursement, repair or replacement is described in Section IV, Paragraph 3 of the Settlement Agreement.

Documentation

If you are seeking reimbursement of expenses you incurred to repair or replace your Side Airbag, you must submit copies of documents and records you have that establish: (1) the amount of out-of pocket expenses you paid to repair or replace the Side Airbag of your vehicle; and (2) the amount of any reimbursement (even if it was only partial reimbursement) that you received for the repair or replacement of the Side Airbag of your vehicle. Such documents may include, but are not limited to: receipts, work orders, repair orders, canceled checks, credit card statements or other documents that may describe the work performed on your vehicle and who performed that work.

IV. VERIFICATION

I declare under penalty of perjury under the laws of the United States of America and the State of California that that I experienced a Reimbursable Deployment of one or more Side Airbags in a Class Vehicle and that the information in this Claim Form is true and correct and that if I am seeking reimbursement, I have provided copies of all of the documents and records within my possession that are requested in Section IV of this Claim Form.

This Claim Form was executed on _____ (month), _____
(year) in _____ (city, state, country).

SIGN YOUR NAME HERE

PRINT OR TYPE YOUR NAME HERE

PLEASE KEEP A COPY OF YOUR COMPLETED CLAIM FORM AND OTHER DOCUMENTATION. THE PROCESSING OF CLAIMS WILL TAKE TIME. NO MONEY WILL BE ISSUED UNTIL AFTER THE EFFECTIVE DATE OF THIS SETTLEMENT. AHM RESERVES THE RIGHT TO AUDIT ANY CLAIM FORMS SUBMITTED. PLEASE CHECK THE SETTLEMENT WEBSITE PERIODICALLY FOR UPDATES ON THE STATUS OF THE SETTLEMENT. THANK YOU FOR YOUR PATIENCE.

Please mail your completed claim form, along with your supporting documentation (if required), so that it is postmarked no later than September 2, 2014 to:

**SIDE AIRBAG SETTLEMENT
c/o Class Administrator
P.O. Box 2718
Torrance, CA 90509**

PE14-004

HONDA

3/28/2014

Q7

Class Action Notification

UNITED STATES DISTRICT COURT
CENTRAL DISTRICT OF CALIFORNIA

HEATHER GUTIERREZ and CONNIE KAUPA,
on behalf of themselves and all others similarly
situated,

Plaintiffs,

vs.

AMERICAN HONDA MOTOR CO., INC., a
California corporation,

Defendant.

Case No. 5:09-cv-01517-JZ-OP

Judge Jack Zouhary

NOTICE OF PROPOSED
CLASS ACTION SETTLEMENT

PLEASE READ THIS NOTICE CAREFULLY AS IT AFFECTS YOUR LEGAL RIGHTS.¹

If you purchased or leased, new or used, one of the following vehicles,

(1) a 2003 Honda Accord Sedan or Coupe with Side Airbags and identified by VIN on the Settlement Website (www.SideAirbagSettlement.com);

(2) a 2004 Accord Sedan with Side Airbags manufactured before April 8, 2004 and identified by VIN on the Settlement Website (www.SideAirbagSettlement.com);

(3) a 2004 Accord Coupe with Side Airbags and identified by VIN on the Settlement Website(www.SideAirbagSettlement.com); or

(4) a 2008 Accord Sedan manufactured before June 12, 2008 (the "Class Vehicles")

then you may be entitled to one of the benefits described below.

A judge has approved and authorized the mailing of this Notice to you because you are a potential member of the Settlement Class. This is not a solicitation from a lawyer.

The purpose of this Notice is to: (a) provide a brief description of the Litigation; (b) inform you of the proposed Settlement; and (c) discuss your rights and options as a member of the Settlement Class. All Settlement Class Members who do not elect to exclude themselves from the Settlement, will release American Honda Motor Co., Inc. ("AHM") and others from claims that were alleged or that could have been alleged in the Litigation ("Released Claims") and will be bound by the Settlement.

SUMMARY OF SETTLEMENT		
	<u>Deployment Class</u>	<u>Injunctive Class</u>
Class Eligibility	You may be a member of the Deployment Class if you purchased or leased, new or used, a Class Vehicle that experienced a Reimbursable Deployment of a Side Airbag and is identified by VIN on the Settlement Website (www.SideAirbagSettlement.com)	You may be a member of the Injunctive Class, if you purchased or leased, new or used, a 2008 Honda Accord Sedan, manufactured before June 12, 2008.

¹ Capitalized terms not otherwise defined herein shall have the meaning ascribed to them in the Class Action Settlement Agreement and Release ("Agreement") available at www.SideAirbagSettlement.com.

Class Benefits	Members of the Deployment Class are eligible to receive one of two benefits: <ul style="list-style-type: none"> • Reimbursement of all expenses incurred, but not previously reimbursed, to repair or replace the Side Airbag following a Reimbursable Deployment; or • Repair or replacement (at AHM's election) at no charge of a Side Airbag that experienced a Reimbursable Deployment <u>prior</u> to the Preliminary Approval Date but had not been previously repaired. 	Members of the Injunctive Class who experience a Reimbursable Deployment of a Side Airbag are eligible to have the Side Airbag repaired or replaced (at AHM's election) at no charge provided that they present a claim for a Reimbursable Deployment to an Authorized Honda Dealer within two (2) years of the Effective Date.
Your Legal Options	<ul style="list-style-type: none"> • Participate in the Settlement; • Opt Out of the Settlement; or • Object to the Settlement. 	<ul style="list-style-type: none"> • Participate in the Settlement; • Opt Out of the Settlement; or • Object to the Settlement.
What You Must Do To Participate In The Settlement	Submit a timely and valid Claim Form by September 2, 2014 along with the required documentation supporting your claim. See Section 10(a) below for more information.	Nothing at this time. If you experience a Reimbursable Deployment within two (2) years of the Effective Date, you must take your vehicle to an Authorized Honda Dealer.
What You Must Do To Opt Out Of The Settlement	You must act by September 2, 2014 . See Section 10(b) Below.	You must act by September 2, 2014 . See Section 10(b) Below.
What You Must Do To Object To The Settlement	You must act by September 2, 2014 . See Section 10(c) Below.	You must act by September 2, 2014 . See Section 10(c) Below.
What You Must Do To Attend The Hearing On November 19, 2014	You must act by October 10, 2014 . See Section 11 Below.	You must act by October 10, 2014 . See Section 11 Below.
What Happens If You Do Nothing	If you do not sign and return a Claim Form, you will not be able to claim benefits under the Settlement, but you will be bound by the Court's judgment.	You are not required to take any action at this time. If you experience a Reimbursable Deployment within two (2) years of the Effective Date, you must take your vehicle to an Authorized Honda Dealer. If you do nothing, you will not receive any benefits and will be bound by the Court's judgment.

1. **SETTLEMENT SCOPE:** Upon final approval of this Settlement, all claims asserted in Gutierrez, et al. v. American Honda Motor Co., Inc., Case No. 5:09-cv-01517-JZ-OP (C.D. Cal., filed Aug. 10, 2009) will be fully and finally resolved.

2. **NATURE OF THE LITIGATION:** Plaintiffs filed a complaint in the United States District Court for the Central District of California, alleging on behalf of themselves and a proposed class that AHM markets, distributes and sells vehicles allegedly equipped with a defective side airbag system in that the side airbags are purportedly prone to inadvertently deploying while the vehicle is being driven under normal conditions. Plaintiffs assert causes of action for violation of Cal. Bus. & Prof. Code § 17200, et seq. and Cal. Civ. Code § 1750, et seq.

AHM expressly denies the allegations in the Litigation and all claims asserted therein and specifically denies that it has engaged in any wrongdoing whatsoever, that the side airbags in Honda Accords are in any sense defective and that it has made any false or misleading statements whatsoever.

On February 13, 2014, the Hon. Jack Zouhary preliminarily approved a proposed Settlement of all of the claims in the Litigation, preliminary certified the Settlement Classes described below and directed Notice as provided for in the Settlement.

3. **NOTICE:** This Notice informs members of the Settlement Class of the Litigation and the proposed Settlement and describes their rights, options and choices. This Notice and the Agreement in its entirety are posted on the Settlement Website at www.SideAirbagSettlement.com and are also available from AHM. Other documents available on the website include the operative complaint filed in the Litigation, the papers that are or will be filed with the Court requesting preliminary and final approval of the Settlement described in this Notice, a copy of this Notice and a Claim Form.

4. **SETTLEMENT CLASSES:** The classes described below have been conditionally certified by the Court. If you are a member of the Settlement Class described in this Notice, the proposed Settlement will affect your legal rights.

Injunctive Class: All Persons in the United States and the District of Columbia who purchased or leased a new or used 2008 Accord Sedan manufactured before June 12, 2008.

Specifically excluded from the Injunctive Class are the following Persons:

- (i) Class Counsel;
- (ii) AHM; AHM's officers, directors and employees; the officers, directors and employees of AHM's affiliated companies; issuers of extended vehicle warranties; and
- (iii) The judges who have presided over this Litigation.

Deployment Class: All Persons in the United States and the District of Columbia who purchased or leased: (1) a 2003 Honda Accord Sedan or Coupe with Side Airbags for which the owner or lessee complained to AHM or an Authorized Honda Dealer about a Reimbursable Deployment of a Side Airbag and identified by VIN in an Exhibit that is to be filed with the Court prior to the Notice Date; (2) a 2004 Accord Sedan with Side Airbags manufactured before April 8, 2004 which the owner or lessee complained to AHM or an Authorized Honda Dealer about a Reimbursable Deployment of a Side Airbag and identified by VIN in an Exhibit that is to be filed with the Court prior to the Notice Date; (3) a 2004 Accord Coupe with Side Airbags which the owner or lessee complained to AHM or an Authorized Honda Dealer about a Reimbursable Deployment of a Side Airbag and identified by VIN in an Exhibit that is to be filed with the Court prior to the Notice Date; and (4) a 2008 Accord Sedan manufactured before June 12, 2008 with Side Airbags for which the owner or lessee complained to AHM or an Authorized Honda Dealer about a Reimbursable Deployment of a Side Airbag and identified by VIN in an Exhibit that is to be filed with the Court prior to the Notice Date.

Specifically excluded from the Deployment Class are the following Persons:

- (i) Class Counsel;
- (ii) AHM; AHM's officers, directors and employees; the officers, directors and employees of AHM's affiliated companies; issuers of extended vehicle warranties; and
- (iii) The judges who have presided over this Litigation.

5. **CLASS COUNSEL:** The Court has appointed the following as counsel for the Injunctive Class and the Deployment Class:

Mike Arias, Esq.
Alfredo Torrijos, Esq.
Arias, Ozzello & Gignac, LLP
6701 Center Drive West, 14th Floor
Los Angeles, California 90045
Telephone: (310) 670-1600
Facsimile: (310) 670-1231
E-mail: marias@aogllp.com
atorrijos@aogllp.com

Jordan S. Esensten, Esq.
Wasserman, Comden, Casselman & Esensten, L.L.P.
5567 Reseda Boulevard, Suite 330
P.O. Box 7033
Tarzana, California 91357
Telephone: (818) 705-6800
Facsimile: (818) 996-8266
E-mail: jesensten@wccelaw.com

Brian D. Chase, Esq.
Bisnar Chase
One Newport Place
1301 Dove Street, Suite 120
Newport Beach, California 92660
Telephone: (949) 752-2999
Facsimile: (949) 752-2777
E-mail: bchase@bisnarchase.com

6. **AN EXPLANATION OF THE PROPOSED SETTLEMENT:** If the Court approves the proposed Settlement at the Final Approval Hearing and the Settlement becomes Final (in other words, no longer subject to appeal and therefore in effect (the date on which this occurs being the "Effective Date")), AHM will provide the following benefits to eligible members of the Injunctive Class and Deployment Class:

a. **The Deployment Class.** A member of the Deployment Class may be entitled to reimbursement of expenses incurred but not previously reimbursed to repair or replace a Side Airbag that experienced a Reimbursable Deployment. A member of the Deployment Class will not be entitled to reimbursement for any amounts for which he or she has been previously reimbursed in any manner whatsoever, including but not limited to, any amounts paid by insurance, discounts given by the Person who performed work on the Side Airbag and vehicle or "goodwill" or other credits from AHM or others.

A member of the Deployment Class who experienced a Reimbursable Deployment of a Side Airbag, but who has not yet had the Side Airbag repaired or replaced may be entitled to bring his or her vehicle to an Authorized Honda Dealer for repair or replacement (at AHM's election) at no charge.

To obtain reimbursement, you must timely submit a completed Claim Form on or before **September 2, 2014**. Depending upon your claim, you may also be required to submit documentation supporting your claim that you experienced a Reimbursable Deployment and the amount of out-of-pocket expenses you incurred to repair or replace the Side Airbag. If you do not already have such documentation, you may obtain such documents from the Authorized Honda Dealer or other automotive repair shop that repaired your vehicle. AHM reserves the right to audit all Claim Forms and to deny reimbursement, repair or

replacement if there is evidence that abuse or misuse of the vehicle caused the Side Airbag to deploy or that the vehicle otherwise did not experience a Reimbursable Deployment. The process for addressing any disputes regarding denial of reimbursement is set forth in the Settlement Agreement. **Please note that Claim Forms for reimbursement will not be processed until after the Effective Date, and reimbursement will not be provided until after the Effective Date. Claim Forms for members of the Deployment Class who have not yet had their Side Airbags repaired or replaced will be processed upon receipt so that the class members may present their vehicles to an Authorized Honda Dealer as soon as possible.**

b. **The Injunctive Class.** For two (2) years after the Effective Date and subject to the terms of the Settlement Agreement, AHM agrees to repair or replace (at AHM's election) the Side Airbag for members of the Injunctive Class who experience a Reimbursable Deployment of a Side Airbag, provided that the member of the Injunctive Class presents his or her vehicle to an Authorized Honda Dealer within the two (2) years of the Effective Date. AHM has the right to deny, in its discretion, repair or replacement to a member of the Injunctive Class if there is evidence that abuse or misuse of his or her vehicle caused the Side Airbag to deploy or that the vehicle otherwise did not experience a Reimbursable Deployment. The process for addressing any disputes regarding denial of repair is set forth in the Settlement Agreement. **Members of the Injunctive Class are encouraged to present their vehicles to an Authorized Honda Dealer as soon as possible after experiencing a Reimbursable Deployment.**

7. **CLASS COUNSEL'S FEES, EXPENSES AND NAMED PLAINTIFF INCENTIVE AWARDS:** Class Counsel will collectively request, as part of the final approval of the Settlement, that the Court approve a payment of up to \$1,180,000 in Attorneys' Fees and Expenses and an aggregate payment of \$15,000 to the class representatives in consideration for their participation and the time each devoted to this litigation. **These payments will not reduce the benefits that the Settlement Class may receive.**

8. **ADMINISTRATIVE COSTS:** All administrative costs of settlement, including the cost of notice, claims administration, cost of the Settlement Administrator, and any other costs of settlement shall be paid by AHM and will not reduce any potential benefits to the Settlement Class Members.

9. **RESULT IF COURT APPROVES SETTLEMENT:** If the Court approves the proposed Settlement, the Litigation will be dismissed, and AHM will provide the benefits described above to Settlement Class Members. After the Litigation is dismissed, no Settlement Class Member who did not request exclusion will be able to file his or her own lawsuit for recovery for any of the Released Claims.

10. **YOUR CHOICES:**

a. **Participate In The Settlement.** If the Court approves the Settlement, you will automatically become eligible to receive some or all of the benefits described above. If you are a member of the Deployment Class, you must timely complete and submit a Claim Form. If you are a member of the Injunctive Class, you need not do anything at this time. Unless you exclude yourself from the Settlement, you are staying in the Settlement Class, and that means that you cannot sue, continue to sue, or be part of any other lawsuit against AHM about the legal issues in this case. It also means that all of the Court's orders will apply to you and legally bind you. A description of the "Released Claims," which explains exactly the legal claims that you give up if you do not exclude yourself from the Settlement, is set forth in the Settlement Agreement available at www.SideAirbagSettlement.com. If you wish to comment in favor of the proposed Settlement, you may mail your comment to SIDE AIRBAG SETTLEMENT c/o Class Administrator, P.O. Box 2718, Torrance, CA 90509, and your comment will be forwarded to Class Counsel and the Court. Alternatively, you may send your comments directly to any Class Counsel at the addresses listed in Paragraph 5.

b. **Exclude Yourself From The Settlement.** If you are a member of the Settlement Class and wish to be excluded from the Settlement, you must mail an Opt Out request, postage prepaid, postmarked no later than **September 2, 2014** to the following address: SIDE AIRBAG SETTLEMENT c/o Class Administrator, P.O. Box 2718, Torrance, CA 90509. A request to exclude yourself from the Settlement must include (i) your name, address, telephone number, (ii) the model year and VIN of your Accord, and (iii) a

signed statement indicating your wish to be excluded from the Settlement Class. If you do not timely submit an Opt Out request including all of the above information, you will be bound by the Settlement and all of your claims for any of the Released Claims will be released. If you validly and timely request exclusion from the Settlement Class, you will not be bound by the Final Order and Judgment entered in this Litigation. Excluding yourself means you cannot receive any of the benefits of the Settlement or comment upon the Settlement, but you will be able to file a lawsuit on your own behalf. If you have any questions concerning these procedures, please contact Class Counsel.

c. **Filing Written Objections.** If you are a member of the Settlement Class and you do not Opt Out, you may object to the terms of the Settlement, the Attorneys' Fees and Expenses, and/or the incentive awards to the class representatives. If you object and the Settlement is approved, you will be barred from bringing your own lawsuit, and you will be bound by the Final Order and Judgment entered in this Litigation. You may, but need not, enter an appearance through counsel of your choice. If you do retain counsel, however, you will be responsible for your own counsel's fees and costs, and in any event, AHM will bear no responsibility for such fees and costs. If you object to the Settlement, you or your counsel must on or before **September 2, 2014** file with the Court and serve on Class Counsel and AHM (to the respective addresses listed on this Notice) a written objection including: (i) your name, address and telephone number and, if represented by counsel, of your counsel; (ii) the model year and VIN of your vehicle; (iii) a written statement of all grounds for the objection accompanied by any legal support for such objection; (iv) copies of any papers, briefs or other documents upon which the objection is based; (v) a statement of whether you intend to appear at the Final Approval Hearing; and (vi) if you intend to appear at the Final Approval Hearing through counsel, the objection must also identify the attorney(s) who is representing you and who will appear at the Final Approval Hearing. In addition, any Settlement Class Member who intends to appear and address the Court at the Final Approval Hearing (including through counsel) must on or before **October 10, 2014** file with the Clerk of the Court a notice of appearance and, if necessary, a *pro hac vice* application. The address for filing any documents with the Court is George E. Brown, Jr. Federal Building and United States Courthouse, 3470 Twelfth Street, Riverside, CA 92501-3801. **Settlement Class Members who do not timely make their objections in accordance with the procedures set forth above waive all objections and may not be heard at the Final Approval Hearing or have the right to appeal approval of the Settlement.** If you have any questions concerning these procedures, please contact any Class Counsel.

11. **FINAL APPROVAL HEARING:** A hearing will be held at the Ninth Circuit Court of Appeals, Richard H. Chambers Courthouse, 125 South Grand Avenue, Pasadena, California 91105 on November 19, 2014 at 9:00 a.m., Judge Jack Zouhary presiding. At the Final Approval Hearing, the Court will decide whether the proposed Settlement is fair, reasonable and adequate and should be approved and, if so, approve the Attorneys' Fees and Expenses and Plaintiffs' Incentive Awards. The time, date and location of this Final Approval Hearing may be changed by the Court without further notice to you. Any member of the Settlement Class may attend the Final Approval Hearing. Any member of the Settlement Class who does not request exclusion may also enter an appearance through counsel, but all fees and costs of such counsel are the responsibility of the member of the Settlement Class. If you wish to attend or have your attorney attend the hearing on your behalf, you may do so, but if you or your attorney would like to address the Court during the hearing, you must follow the procedures set forth in Paragraph 10(c) above. If you plan to attend the hearing, you should confirm its time, date and location. Any updates or changes on the time, date or location of this hearing will be posted on the Settlement Website at www.SideAirbagSettlement.com.

12. **ADDITIONAL INFORMATION:** For additional information, you may call 1-888-888-3082 or visit www.SideAirbagSettlement.com.

Please do not call or write the Court or the Office of the Clerk except as directed by this Notice.

PE14-004

HONDA

3/28/2014

Q9

a	The date or approximate date on which the modification or change was incorporated into vehicle production;	Css Production: June 30th, 2008 HAM Production: June 5th, 2008
b	A detailed description of the modification or change;	Changing of the crash parameters
c	The reason(s) for the modification or change;	Product improvement
d	The part number(s) (service and engineering) of the original component;	77960-TA0-A01 UNIT ASSY,SRS 77960-TA0-L01 UNIT ASSY,SRS
e	The part number(s) (service and engineering) of the modified component;	77960-TA0-A02 UNIT ASSY,SRS 77960-TA0-L02 UNIT ASSY,SRS
f	Whether the original unmodified component was withdrawn from production and/or sale, and if so, when;	77960-TA0-A01: withdrawn date 07/06/2009 77960-TA0-L01: withdrawn date 11/12/2008
g	When the modified component was made available as a service component;	77960-TA0-A02: available date 06/09/2008 77960-TA0-L02: available date 06/24/2008
h	Whether the modified component can be interchanged with earlier production components.	Yes

PE14-004

HONDA

3/28/2014

Q9

Mass Production Spec Notice
Supplemental Sheet

仕様通知附表

DESIGN CHANGE NOTICE

製作所
C PLANT

作成

08-06-23 AS OF

FAMILY
C42

通知
D/C
C48-2-1702

PAGE
2

CTL.BLOCK

LEVEL	NEW PART No.		SP	SN	BLOCK	派生機種 TYPE										派生機種 TYPE										適用指示 APPL-INSTRUC.				
	OLD PART No.		互換 I/C.ABILITY		SECTION	LOC.GR. 基本 E 派生										LOC.GR. 基本 E 派生										順位 本 切換年月 等級				
	PART NAME		概略 REASON		ITEM No.	NEW/OLD S/MODEL OP TYPE										NEW/OLD S/MODEL OP TYPE										SEQ/T/F EFFECTIVE RANK/LOT				
A	1	77960-TA0 -K020-M4		4	S	**SEPPEN TEKIYO*** "APPLICATION/QUANTITY CHANGE"***										**SEPPEN TEKIYO*** "APPLICATION/QUANTITY CHANGE"***										1 2 080616Y				
B	U	77960-TA0 -K011-M4			NY	F47	BB	1TA5A2	KA	1		1						BB	1TA5A2	KB	1		1							
C		UNIT ASSY,SRS		01		77960	BB	1TA5A2	KC	1		1						BB	1TA5A2	KD	1		1							
D				S	M	M	BB	1TA5A2	KE	1		1						BB	1TA5A2	KF	1		1							
A	2	7796Z-TA0 -A020-M4		4	N		BB	1TA5Z2	KA	1		1						BB	1TA5Z2	KB	1		1							
B	U	7796Z-TA0 -A011-M4			NY		BB	1TA5Z2	KC	1		1						BB	1TA5Z2	KD	1	1	1							
C		SPEC UNIT ASSY SRS		01			BB	1TA5Z2	KE	1		1						BB	1TA5Z2	KF	1		1							
D				Z		4	BB	1TA6A2	KA			1						BB	1TA6A2	KB			1							
A	2	77960-TA0 -ZZ12-M4		4	N		BB	1TA6Z2	KA			1						BB	1TA6Z2	KB			1							
B	U	77960-TA0 -ZZ11-M4			YY																									
C		DWG UNIT ASSY SRS		02																										
D				S	Z	5																								

手配系列
PROCESS LOCATION

D/C PART	LOC.GR.	連依存度	実施年月日	手配記号	P属色	M	段	手配記号	P属色	M	段	手配記号	P属色	M	段	手配記号	P属色	M	段	手配記号	P属色	M	段	手配記号	P属色	M	段	手配記号	P属色	M	段
77960-TA0 -K020-M4	C	BB1100	080424	LP	4		*																								
7796Z-TA0 -A020-M4	C	AA1100	080424	LP	4		*																								
77960-TA0 -ZZ12-M4	C	CC1100	080424	LP	4		*																								

概略コード D/C REASON 01変更 02改訂 03新設新図 04流用 05量試 06暫定 07部番変更 08材質変更 09名 10廃止 11設変中止 12旧図復活 13整備図 14適用変更 15個数変更 17管理修正 18未出図発行 25部番統合
 31廃止部品の変更 32廃止部品の改訂 33割込新設 40構成変更 41構成流用復活 50次変A-B 60改廃設変 70親離れ 71親新設 72ケ/親変更 73Cマーク新設 74Cマーク廃止 802/4/汎内廃止 81SS/2/4/汎内廃止 82色別親変更 83素材共用新設
 84素材共用廃止 85適用機種指定 86使用先親設定 90手配系列変更 91内外作変更 92色別適用変更 93KD現調変更 94ベース機種適用流用 95機種廃止 96適用日親変更 97M/L変更 98OP適用変更 99部番区分変更 【700】

仕様通知附表

DESIGN CHANGE NOTICE

製作所
C PLANT 08-06-23 AS OF

FAMILY	通知 D/C	PAGE
C42	C48-2-1702	3

CTL.BLOCK

LEVEL	NEW PART No. OLD PART No. PART NAME	S P : S N : C 互換 I/C.ABILITY 概略 REASON 種類 DRW.ID:SIZE	BLOCK SECTION ITEM No. 個/親 QTY.	手配区分 LOC.GR. 新:旧	切 換 順 位	基 本 機 種	E / F	派 生 上 桁 T Y P E	派生機種 TYPE										手配区分 LOC.GR. 新:旧	切 換 順 位	基 本 機 種	E / F	派 生 上 桁 T Y P E	派生機種 TYPE										適用指示 APPL-INSTRUC.			
									0	1	2	3	4	5	6	7	8	9						0	1	2	3	4	5	6	7	8	9	順位 SEQ/T/F	版本 EFFECTIVE	切換年月	等級 RANK
1 A B C D	77960-TA0 -L020-M4 77960-TA0 -L010-M4 UNIT ASSY,SRS	4 S NY S Z 5	F47 77960	**SEPPEN		TEKIYO			"APPLICATION/QUANTITY CHANGE"																								1	2	080714	D	
2 A B C D	7796Z-TA0 -L020-M4 7796Z-TA0 -L010-M4 SPEC.UNIT ASSY SRS	4 N NY Z 4	1M	**KYUU		TEKIYO			"PREVIOUS APPLICATION"																								2	2	080721	Y	
3 A B C D																																					
4 A B C D			F47 77960																																		
5 A B C D																																					
6 A B C D																																					
7 A B C D																																					

手配系列
PROCESS LOCATION

概略コード D/C REASON 01変更 02改訂 03新設新図 04流用 05量試 06暫定 07部番変更 08材質変更 09名 10廃止 11設変中止 12旧図復活 13整備図 14適用変更 15個数変更 17管理修正 18未出図発行 25部番統合
 31廃止部品の変更 32廃止部品の改訂 33割込新設 40構成変更 41構成流用復活 50次変A-B 60改廃設変 70親離れ 71親新設 72ケ/親変更 73Cマーク新設 74Cマーク廃止 802/4/汎内廃止 81SS/2/4/汎内廃止 82色別親変更 83素材共用新設
 84素材共用廃止 85適用機種指定 86使用先親設定 90手配系列変更 91内外作変更 92色別適用変更 93KD現調変更 94ベース機種適用流用 95機種廃止 96適用日親変更 97M/L変更 98OP適用変更 99部番区分変更 【700】

仕様通知附表

DESIGN CHANGE NOTICE

製作所 作成
C PLANT 08-06-23 AS OF

FAMILY	通知 D/C	PAGE
C42	C48-2-1702	4

CTL.BLOCK

LEVEL	NEW PART No. OLD PART No. PART NAME	S P : S N : C 互換 I/C.ABILITY 概略 REASON 種類 DRW.ID:SIZE	BLOCK SECTION ITEM No. 個/親 QTY.	手配区分 LOC.GR. 新:旧 NEW:OLD	切 換 順 位 機 種 S MODEL	E / F O P	派生 上 桁 T Y P E	派生機種 TYPE										手配区分 LOC.GR. 新:旧 NEW:OLD	切 換 順 位 機 種 S MODEL	E / F O P	派生 上 桁 T Y P E	派生機種 TYPE										適用指示 APPL-INSTRUC.				
								0	1	2	3	4	5	6	7	8	9					0	1	2	3	4	5	6	7	8	9	順位 SEQ/T/F	本 切 換 年 月 EFFECTIVE	等級 RANK	引 出 欄 外 LOT	
1	77960-TA0 -X020-M4 77960-TA0 -X011-M4 UNIT ASSY,SRS	4 S NY F47 77960		**SE	BB		TEKIYO***	"APPLICATION/QUANTITY CHANGE"***										BB													1	2	080616	Y		
2	7796Z-TA0 -A020-M4 7796Z-TA0 -A011-M4 SPEC,UNIT ASSY SRS	4 N NY 01 Z 4 1M		BB														BB																		
3	77960-TA0 -ZZ12-M4 77960-TA0 -ZZ11-M4 DWG,UNIT ASSY SRS	4 N YY 02 S Z 5 1M																																		
4																																				
5																																				
6																																				
7																																				

手配系 列	D/C PART	LOC.GR.	連 依 存 度 PT	量 試 SHR%	実 施 年 月 日 BEING DATE	手 配 記 号 LOCATION	P 属 色 T	M 段 L	G	手 配 記 号 LOCATION	P 属 色 T	M 段 L	G	手 配 記 号 LOCATION	P 属 色 T	M 段 L	G	手 配 記 号 LOCATION	P 属 色 T	M 段 L	G	手 配 記 号 LOCATION	P 属 色 T	M 段 L	G	手 配 記 号 LOCATION	P 属 色 T	M 段 L	G	
			77960-TA0 -X020-M4	C	BB	1100	080424	LP	4		*																			
	7796Z-TA0 -A020-M4	C	AA	1100	080424	LP	4		*																					
	77960-TA0 -ZZ12-M4	C	CC	1100	080424	LP	4		*																					

概略コード D/C REASON 01変更 02改訂 03新設新図 04流用 05量試 06暫定 07部番変更 08材質変更 09名 10廃止 11設変中止 12旧図復活 13整備図 14適用変更 15個数変更 17管理修正 18未出図発行 25部番統合
 31廃止部品の変更 32廃止部品の改訂 33割込新設 40構成変更 41構成流用復活 50次変A-B 60改廃設変 70親離れ 71親新設 72ケ/親変更 73Cマーク新設 74Cマーク廃止 802/4/汎内廃止 81SS/2/4/汎内廃止 82色別親変更 83素材共用新設
 84素材共用廃止 85適用機種指定 86使用先親設定 90手配系列変更 91内外作変更 92色別適用変更 93KD現調変更 94ベース機種適用流用 95機種廃止 96適用日親変更 97M/L変更 98OP適用変更 99部番区分変更
【700】
END

PE14-004

HONDA

3/28/2014

Q9

Q9-1 Mass Production Spec
Notice English_Redacted

Revision No.

48-2-1702

2/2

SUPPLEMENTAL

No.	Part Name	Description												
	SPEC, UNIT ASSY SRS 77962-TAO-A020 L020 -H9	<p>P276</p> <p>8.2.2.1 Parameters in SRS.</p> <ul style="list-style-type: none"> parameter version. a2PX-ECU17S. Par ⇒ a2PX-ECU21S. Par parameter ID [REDACTED] ⇒ [REDACTED] B-pillar SIS HS-PATH-min. [REDACTED] ⇒ [REDACTED] <p>P 270 Table 8-3</p> <table border="1" data-bbox="592 976 1372 1081"> <tr> <td>14</td> <td>Front ; a2pxu-12f- ECU. Par Side ; a2pxu-ECUY-17s. Par</td> </tr> </table> <p style="text-align: center;">↓</p> <table border="1" data-bbox="592 1155 1356 1354"> <tr> <td>14</td> <td>Front ; a2pxu-12f- ECU. Par Side ; a2pxu-ECUY-17s. Par</td> </tr> <tr> <td>15</td> <td>Front ; a2pxu-14f- ECU Par Side ; a2pxu-ECUY-21s. Par</td> </tr> </table> <p>Table 8-4</p> <table border="1" data-bbox="592 1575 1323 1680"> <tr> <td>24</td> <td>Front ; a2pxu-12f- ECU. Par Side ; a2pxu-ECUY-17s. Par</td> </tr> </table> <p style="text-align: center;">↓</p> <table border="1" data-bbox="592 1764 1323 1953"> <tr> <td>24</td> <td>Front ; a2pxu-12f- ECU. Par Side ; a2pxu-ECUY-17s. Par</td> </tr> <tr> <td>25</td> <td>Front ; a2pxu-12f- ECU. Par Side ; a2pxu-ECUY-21s. Par</td> </tr> </table>	14	Front ; a2pxu-12f- ECU. Par Side ; a2pxu-ECUY-17s. Par	14	Front ; a2pxu-12f- ECU. Par Side ; a2pxu-ECUY-17s. Par	15	Front ; a2pxu-14f- ECU Par Side ; a2pxu-ECUY-21s. Par	24	Front ; a2pxu-12f- ECU. Par Side ; a2pxu-ECUY-17s. Par	24	Front ; a2pxu-12f- ECU. Par Side ; a2pxu-ECUY-17s. Par	25	Front ; a2pxu-12f- ECU. Par Side ; a2pxu-ECUY-21s. Par
14	Front ; a2pxu-12f- ECU. Par Side ; a2pxu-ECUY-17s. Par													
14	Front ; a2pxu-12f- ECU. Par Side ; a2pxu-ECUY-17s. Par													
15	Front ; a2pxu-14f- ECU Par Side ; a2pxu-ECUY-21s. Par													
24	Front ; a2pxu-12f- ECU. Par Side ; a2pxu-ECUY-17s. Par													
24	Front ; a2pxu-12f- ECU. Par Side ; a2pxu-ECUY-17s. Par													
25	Front ; a2pxu-12f- ECU. Par Side ; a2pxu-ECUY-21s. Par													

PE14-004

HONDA

3/28/2014

Q9

Q9-1 Mass Production Spec
Notice Japanese_Redacted

SUPPLEMENTAL

No.	Part Name	Description																
	SPEC, UNIT ASSY SRS 77962-TAO-A020 L020 -M4	<p>P276</p> <p>8.2.2.1 Parameters in SRS.</p> <ul style="list-style-type: none"> • parameter version. a2PX-ECU17S.Par ⇒ a2PX-ECU21S.Par • parameter ID █████ ⇒ █████ • B-pillar SIS HS-Path-min. █████ ⇒ █████ <p>P270 Table 8-3</p> <table border="1" style="margin-left: 20px; border-collapse: collapse;"> <tr> <td style="width: 10%; text-align: center;">14</td> <td style="padding: 5px;"> Front ; a2pxu-12f-ECU.Par Side ; a2pxu-ECUY-17s.Par </td> </tr> <tr> <td colspan="2" style="text-align: center;">↓</td> </tr> <tr> <td style="text-align: center;">14</td> <td style="padding: 5px;"> Front ; a2pxu-12f-ECU.Par Side ; a2pxu-ECUY-17s.Par </td> </tr> <tr> <td style="text-align: center;">15</td> <td style="padding: 5px;"> Front ; a2pxu-12f-ECU.Par Side ; a2pxu-ECUY-21s.Par </td> </tr> </table> <p>Table 8-4</p> <table border="1" style="margin-left: 20px; border-collapse: collapse;"> <tr> <td style="width: 10%; text-align: center;">24</td> <td style="padding: 5px;"> Front ; a2pxu-12f-ECU.Par Side ; a2pxu-ECUY-17s.Par </td> </tr> <tr> <td colspan="2" style="text-align: center;">↓</td> </tr> <tr> <td style="text-align: center;">24</td> <td style="padding: 5px;"> Front ; a2pxu-12f-ECU.Par Side ; a2pxu-ECUY-17s.Par </td> </tr> <tr> <td style="text-align: center;">25</td> <td style="padding: 5px;"> Front ; a2pxu-12f-ECU.Par Side ; a2pxu-ECUY-21s.Par </td> </tr> </table>	14	Front ; a2pxu-12f-ECU.Par Side ; a2pxu-ECUY-17s.Par	↓		14	Front ; a2pxu-12f-ECU.Par Side ; a2pxu-ECUY-17s.Par	15	Front ; a2pxu-12f-ECU.Par Side ; a2pxu-ECUY-21s.Par	24	Front ; a2pxu-12f-ECU.Par Side ; a2pxu-ECUY-17s.Par	↓		24	Front ; a2pxu-12f-ECU.Par Side ; a2pxu-ECUY-17s.Par	25	Front ; a2pxu-12f-ECU.Par Side ; a2pxu-ECUY-21s.Par
14	Front ; a2pxu-12f-ECU.Par Side ; a2pxu-ECUY-17s.Par																	
↓																		
14	Front ; a2pxu-12f-ECU.Par Side ; a2pxu-ECUY-17s.Par																	
15	Front ; a2pxu-12f-ECU.Par Side ; a2pxu-ECUY-21s.Par																	
24	Front ; a2pxu-12f-ECU.Par Side ; a2pxu-ECUY-17s.Par																	
↓																		
24	Front ; a2pxu-12f-ECU.Par Side ; a2pxu-ECUY-17s.Par																	
25	Front ; a2pxu-12f-ECU.Par Side ; a2pxu-ECUY-21s.Par																	

PE14-004

HONDA

3/28/2014

Q10

Q10 Explanation

SRS System Overview

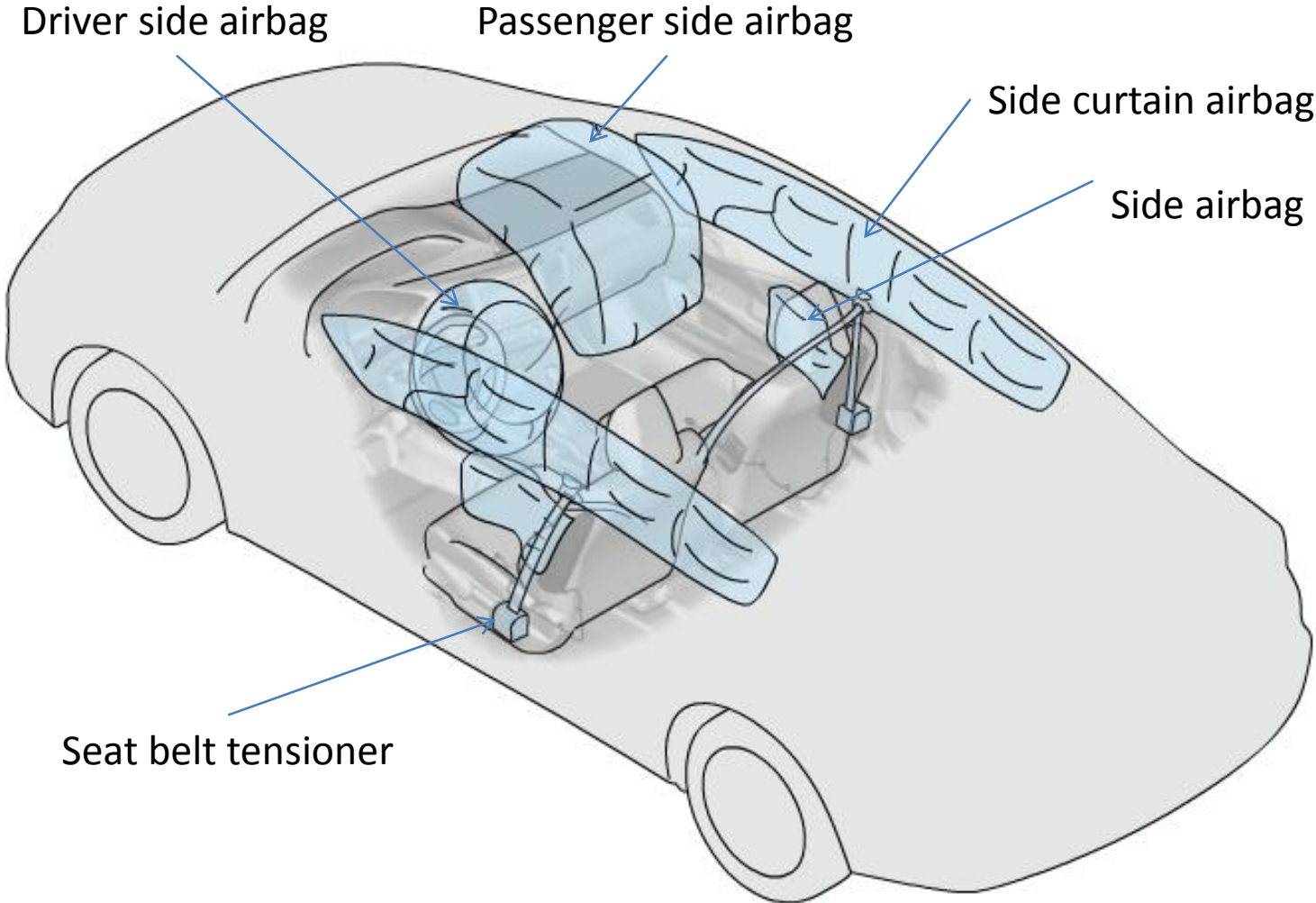

SRS System Overview

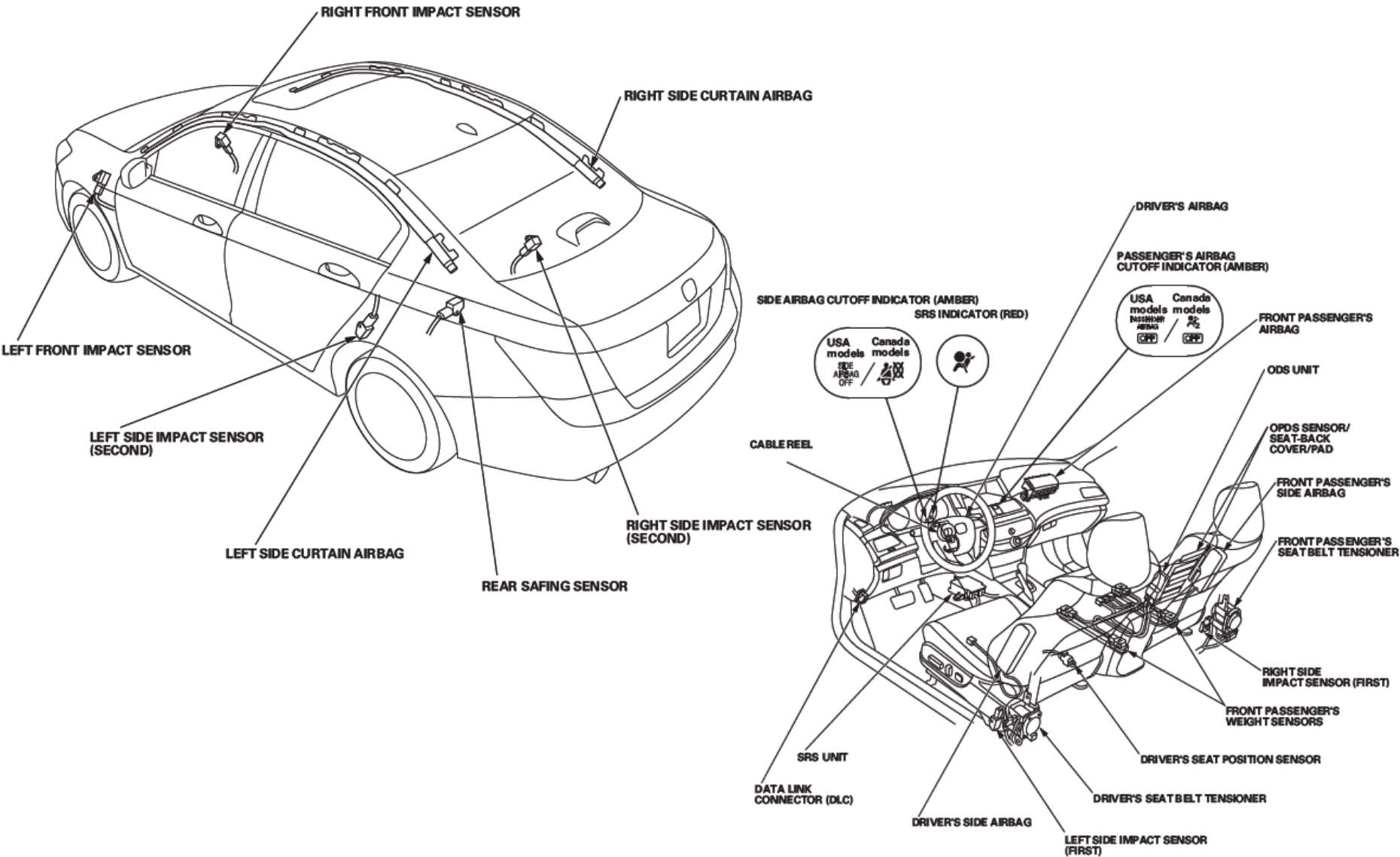

System Block Diagram (Simplified)

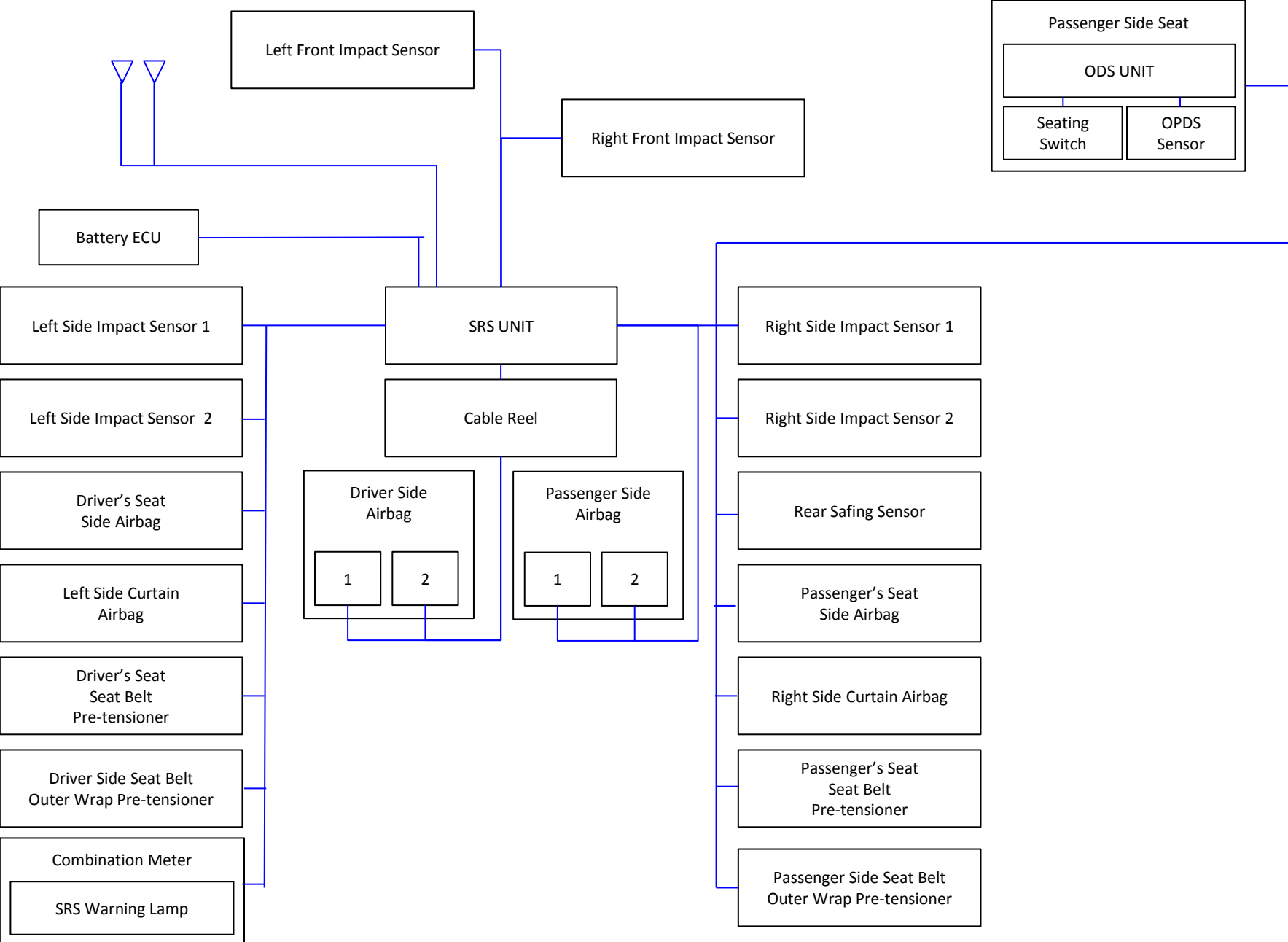

System Block Diagram (ACCORD 4-Door)

4-Door

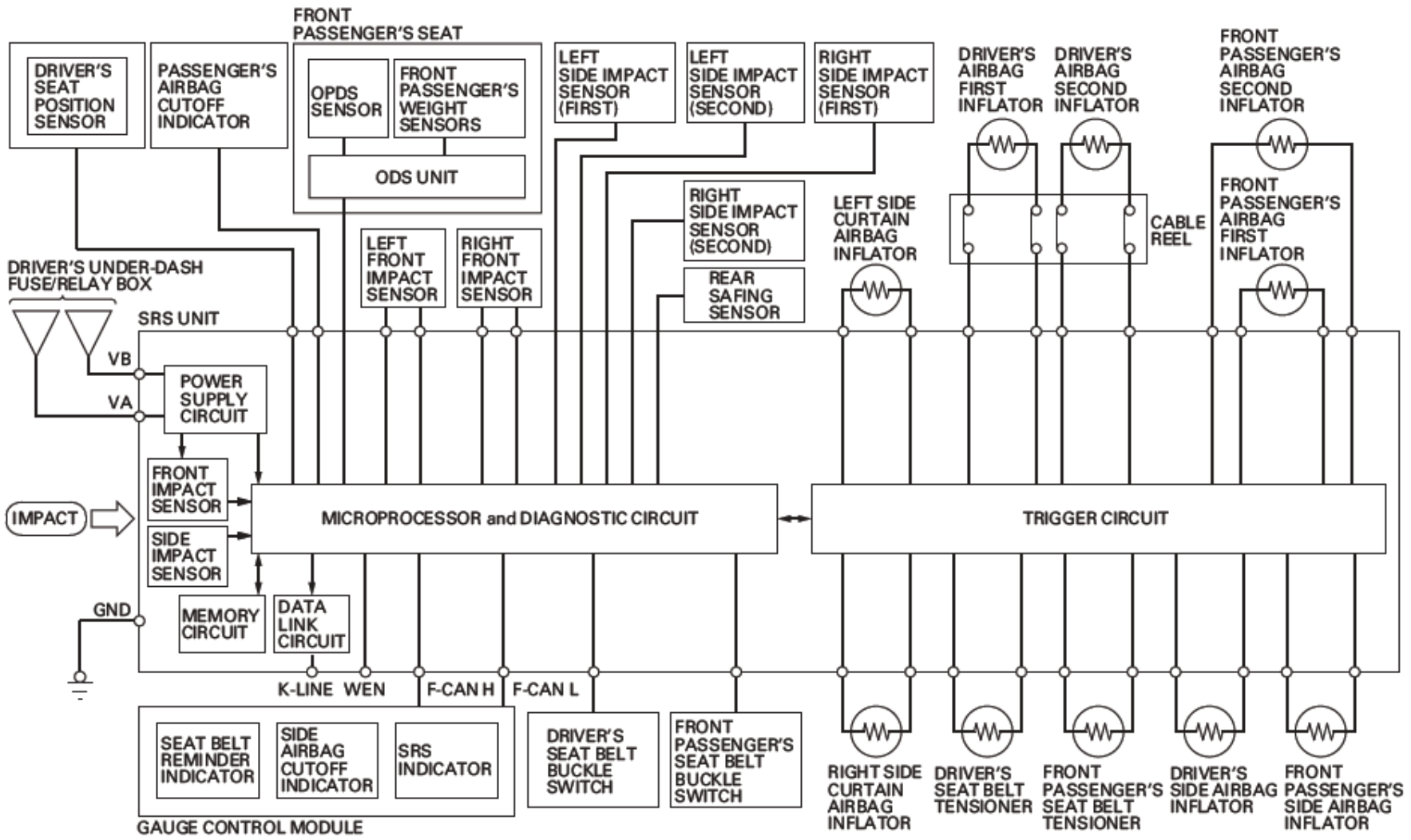

System Block Diagram (ACCORD 2-Door)

2-Door

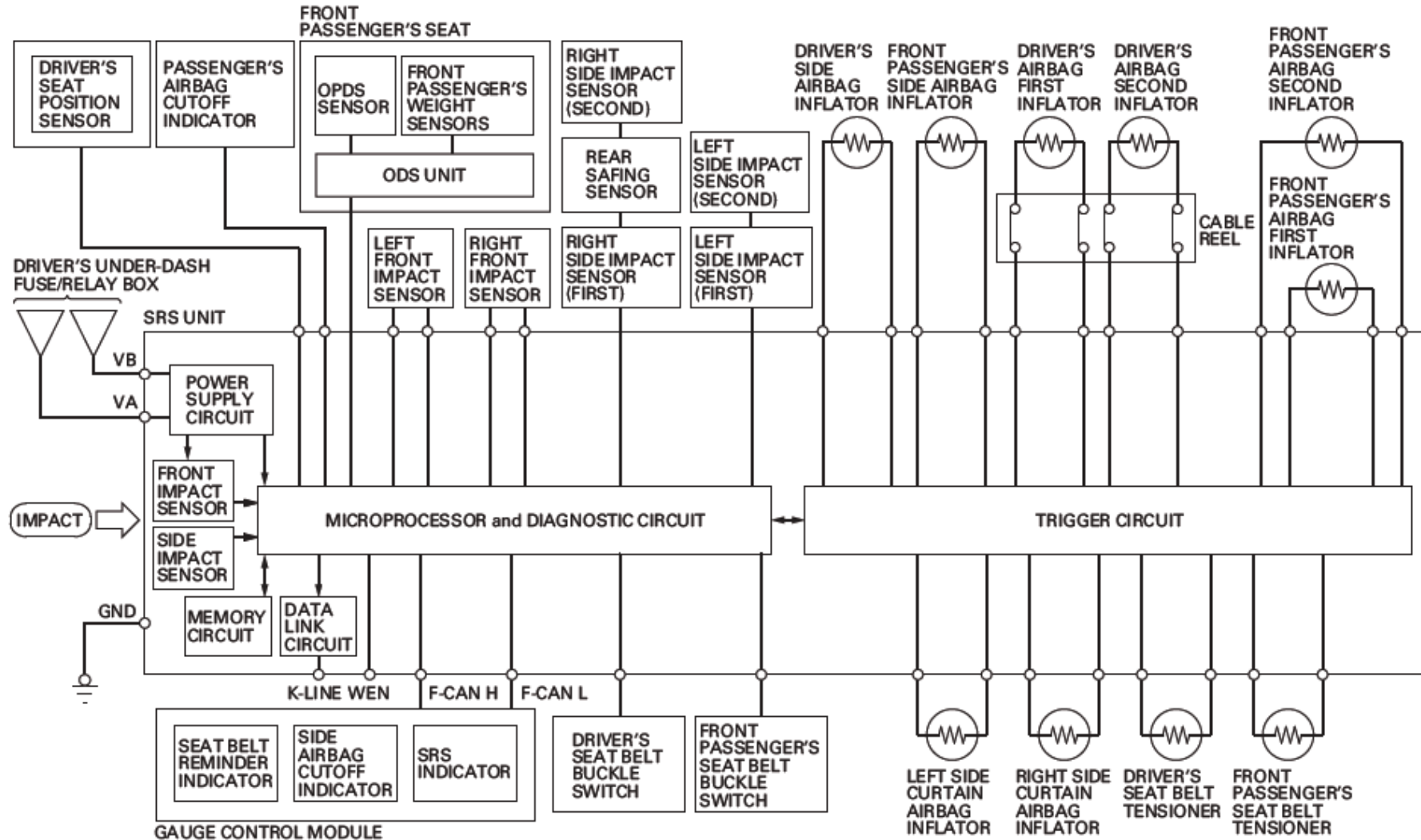

Side Airbag and Side Curtain Airbag Operation Process

The impact generated by side collision will be transmitted to side impact sensor, airbag sensor, and SRS unit.

The collision judgment circuit, inside of the SRS unit, determines if the output from the side impact sensor and airbag sensor exceed the threshold, and then sends a command signal if the output exceeds the threshold.

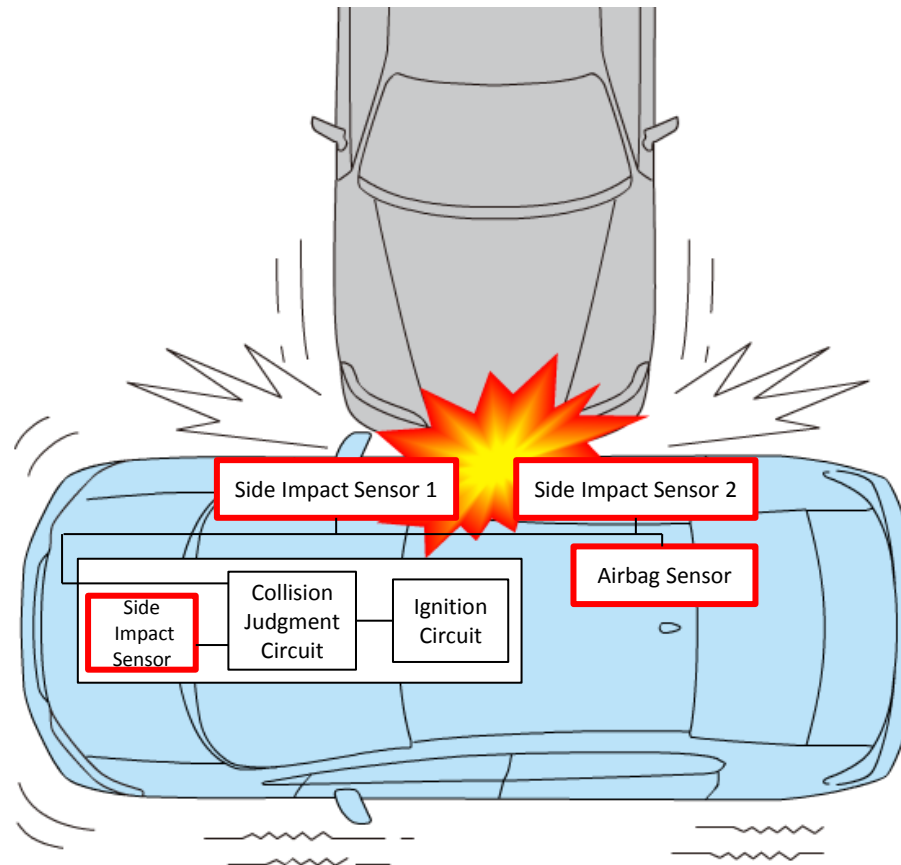

The collision judgment circuit sends a command signal to the ignition circuit, which deploys the side airbag and side curtain airbag.

The side airbag is designed to be inflated by two different pressures in order to reduce the risk of injury to the passenger by deployment.

The side airbag and side curtain airbag are deployed on the side of the vehicle where the impact is detected.

However, to protect the head of the passenger, the side airbag and side curtain airbag may be deployed even with a frontal collision if/when certain lateral force is applied.

SRS System Overview

Driver's Seat Side Airbag

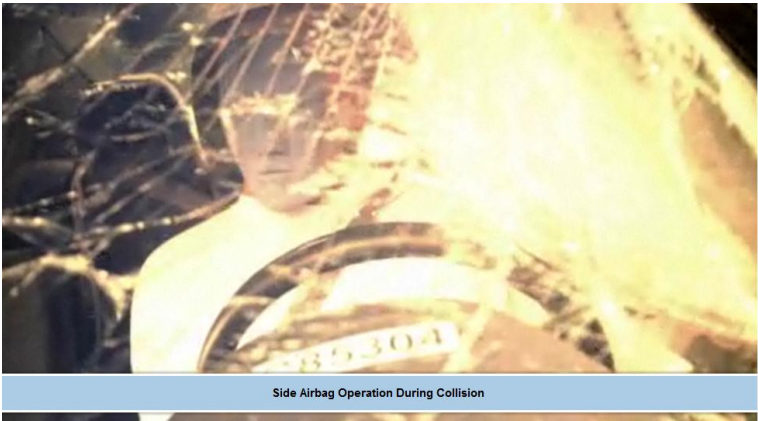

Rear Left Seat Side Airbag

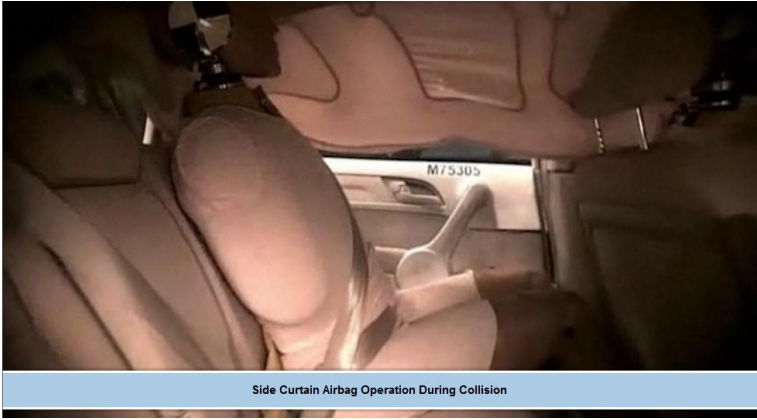

OPDS System Overview

In order to help prevent passenger airbag deployment injuries (mainly children), when a side impact is detected, the OPDS detects the seating situation and judges whether the passenger side airbag can or cannot deploy through use of the OPDS sensors (consisting of a seating height sensor and a cephalic position sensor) and ODS Unit, then transmit the signal to SRS unit.

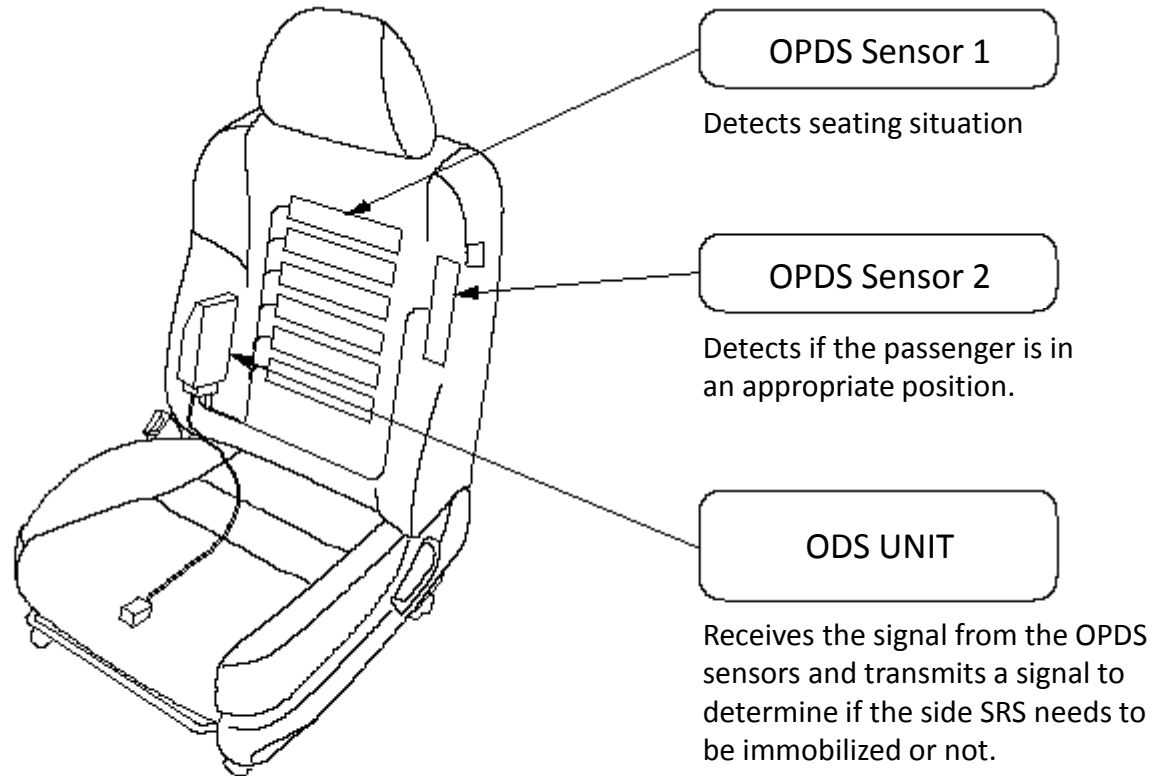

PE14-004

HONDA

3/28/2014

Q10

Q10 Parts List

MY	Model	Code	Development (HGT/HRAO)	Parts No.				Applied device			
				SRS		Side Impact Sensor (SIS)	Satellite Safing Sensor (SSS)	Front A/B	Retractor P/T	Side A/B	Curtain A/B
				M/P Start	After DC"L48-2-1702"	no design change	no design change				
08	US Accord 4Dr	TA0A	HGT	77960-TA0-A011-M4	77960-TA0-A020-M4	77970-TA0-A111-M4	77975-TA0-A111-M4	L (Dual) + R (Dual)	L+R	L+R	L+R
				77960-TA0-L010-M4	77960-TA0-L020-M4	77970-TA0-A111-M4	77975-TA0-A111-M4	L (Dual) + R (Dual)	L+R	L+R	L+R
09		TA0A	HGT	77960-TA0-A020-M4	-	77970-TA0-A111-M4	77975-TA0-A111-M4	L (Dual) + R (Dual)	L+R	L+R	L+R
				77960-TA0-L010-M4	77960-TA0-L020-M4	77970-TA0-A111-M4	77975-TA0-A111-M4	L (Dual) + R (Dual)	L+R	L+R	L+R
10		TA0A	HGT	77960-TA0-A020-M4	-	77970-TA0-A111-M4	77975-TA0-A111-M4	L (Dual) + R (Dual)	L+R	L+R	L+R
				77960-TA0-L020-M4	-	77970-TA0-A111-M4	77975-TA0-A111-M4	L (Dual) + R (Dual)	L+R	L+R	L+R
11		TA0Z	HGT	77960-TA0-A031-M4	-	77970-TA0-A111-M4	77975-TA0-A111-M4	L (Dual) + R (Dual)	L+R	L+R	L+R
12		TA0Z	HGT	77960-TA0-A031-M4	-	77970-TA0-A111-M4	77975-TA0-A111-M4	L (Dual) + R (Dual)	L+R	L+R	L+R

08	US Accord 2Dr	TE0A	HGT	77960-TE0-A012-M1	-	77970-TC0-A111-M1	77975-TE0 -A110-M1	L (Dual) + R (Dual)	L+R	L+R	L+R
09		TE0A	HGT	77960-TE0-A012-M1	-	77970-TC0-A111-M1	77975-TE0 -A110-M1	L (Dual) + R (Dual)	L+R	L+R	L+R
10		TE0A	HGT	77960-TE0-A012-M1	-	77970-TC0-A111-M1	77975-TE0 -A110-M1	L (Dual) + R (Dual)	L+R	L+R	L+R
11		TE1A	HGT	77960-TE1-A010-M1	-	77970-TC0-A111-M1	77975-TE0 -A110-M1	L (Dual) + R (Dual)	L+R	L+R	L+R
12		TE1A	HGT	77960-TE1-A010-M1	-	77970-TC0-A111-M1	77975-TE0 -A110-M1	L (Dual) + R (Dual)	L+R	L+R	L+R

77970-TA0-A111-M4 12M ACURA TL

77970-TC0-A111-M1 09,10,11M FIT and 09,10,11M ACURA TL

77975-TA0-A111-M4 12M ACURA TL

77975-TE0 -A110-M1 09,10,11M ACURA TL and 09,10,11M TSX

PE14-004

HONDA

3/28/2014

Q11

Q11 Supplier Contact and Parts
Demand

SUPPLIER CONTACT INFORMATION

Name: Alberto Ramirez-Mendez

Company: Passive Safety & Sensorics - NAFTA
Continental Automotive Systems, Inc.

Address: One Continental Drive
Auburn Hills, MI 48326

Contact: Tel: 248 391-5665
Fax: 248 764-7112
Mobile: 248 890-9510

E-mail: alberto.ramirez-mendez@continental-corporation.com

Home Page: www.continental-corporation.com

PE14-004

Q1
PARTS DEMAND HISTORY
AS OF 03/20/2014

PART DESCRIPTION	SERVICE PART NO.	MODEL APPLICATION	PART RELEASE DATE	CALENDAR YEAR					
				2009	2010	2011	2012	2013	2014
SRS UNIT	77960-TA0-A01	2008 ACCORD	9/5/2007	N/A	N/A	N/A	N/A	N/A	N/A
SRS UNIT	77960-TA0-A02 (SUPERSEDES 77960-TA0-A01)	2008-2010 ACCORD	6/9/2008	2262	3399	3792	3410	3326	610
SRS UNIT	77960-TA0-L01	2008 ACCORD	9/5/2007	N/A	N/A	N/A	N/A	N/A	N/A
SRS UNIT	77960-TA0-L02 (SUPERSEDES 77960-TA0-L01)	2008-2010 ACCORD	6/24/2008	639	581	575	663	533	99
SIDE IMPACT SENSOR	77970-TA0-A11	2008-2012 ACCORD	9/5/2007	1943	2341	2704	2655	2500	462
SATELLITE SAFING SENSOR	77975-TA0-A11	2008-2012 ACCORD	9/5/2007	320	433	520	553	541	98

Q11
PARTS DEMAND HISTORY
AS OF 03/20/2014

	24-MONTH HISTORY			
	SRS UNIT 77960-TA0-A02	SRS UNIT 77960-TA0-L02	SIDE IMPACT SENSOR 77970-TA0-A11	SATELLITE SAFING SENSOR 77965-TA0-A11
MARCH 2012	249	49	203	43
APRIL 2012	264	49	230	54
MAY 2012	294	45	258	57
JUNE 2012	262	41	188	50
JULY 2012	298	50	177	29
AUGUST 2012	310	69	238	50
SEPTEMBER 2012	296	63	197	45
OCTOBER 2012	304	74	263	60
NOVEMBER 2012	296	67	200	43
DECEMBER 2012	231	35	223	41
JANUARY 2013	317	46	273	57
FEBRUARY 2013	274	40	232	65
MARCH 2013	262	47	227	54
APRIL 2013	243	39	237	54
MAY 2013	279	48	220	41
JUNE 2013	284	46	187	34
JULY 2013	307	56	175	36
AUGUST 2013	319	62	185	41
SEPTEMBER 2013	257	36	194	37
OCTOBER 2013	285	48	219	44
NOVEMBER 2013	221	37	143	30
DECEMBER 2013	278	28	208	48
JANUARY 2014	295	53	212	39
FEBRUARY 2014	204	29	164	32

PE14-004

HONDA

3/28/2014

QQ13a c e_Redacted13

Q13 a, c and e Response

Q13a) The causal or contributory factor(s);

The threshold setting for side impacts did not have enough margin for typical market use, therefore if the door is slammed shut the airbags may deploy.

Q13c) The failure mode(s);

When driver or passenger side door are slammed shut (with over ██████'s force), the side airbag and side curtain airbag can deploy.

Q13e) In the event of the claimed defect or the subject component became inoperative, how the operator and the other passengers are warned inside or outside of the cabin?

1) In the event of claimed defect:

Neither the driver or passengers are warned in advance.

Once the event occurs, the SRS unit detects the airbag deployment and the SRS warning lamp will illuminate on the vehicle instrument panel.

2) In the event the subject component became inoperative:

The self-diagnostic function of the SRS system will detect the failure and the SRS warning lamp will illuminate on the vehicle's instrument panel.

PE14-004

HONDA

3/28/2014

Q13b_Redacted

Failure Mechanism

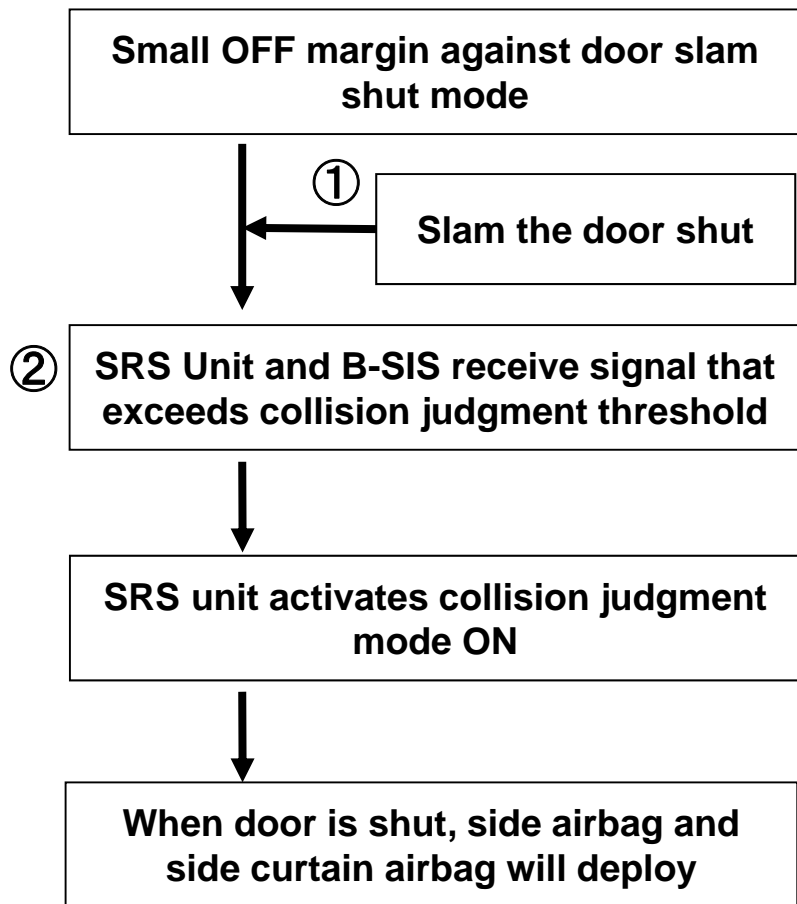

① Slam the door shut

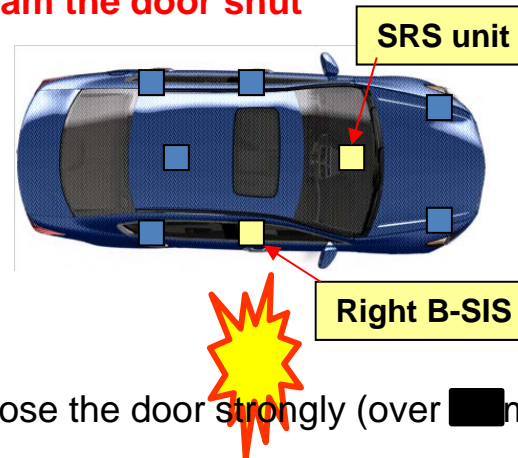

② Collision exceeds collision judgment threshold

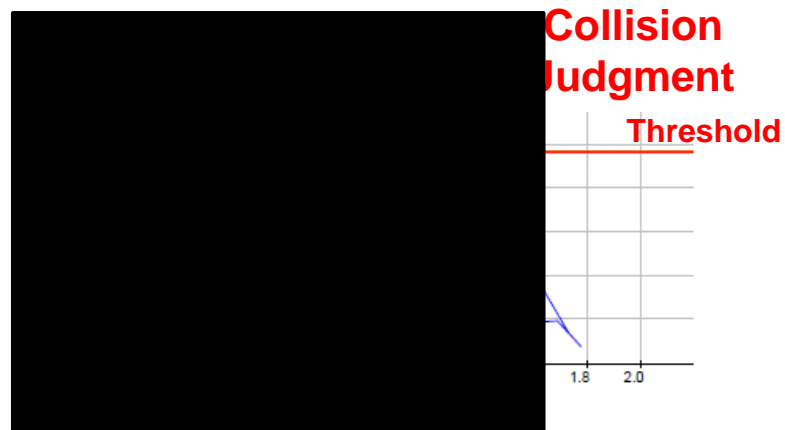

SRS Unit Record G Data

PE14-004

HONDA

3/28/2014

Q13d

North America 08M Accord side curtain airbag deployment test results

Side curtain airbag-related passenger injury test performed following the evaluation method proposed by the Technical Working Group (TWG) in North America.

- Test conditions
 - Dummy used:** SID-IIIs
 - Test Mode:** Forward facing SID-IIIs on raised seat (driver and passenger positions with roof-rail-mounted airbags, first row)
 - TWG Test:** 3.3.5.2

- Injury degree results

Items	Criteria values	Results
HIC (Head Injury Criteria)	Below 779	8.4
Nij (Neck Injury Criteria)	Below 1.0	0.34
Neck Tension [N]	Below 2070	75.7
Neck Compression [N]	Below 2520	966.6

- Image before/after test

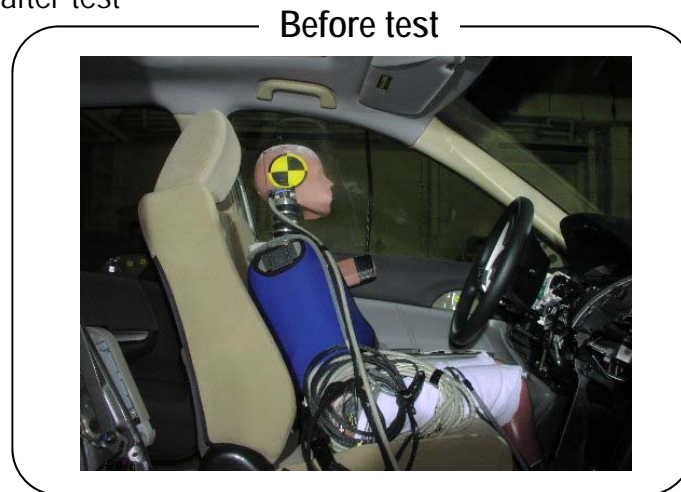

The results fall far below the criteria values with no serious injury to passengers.

North America 08M Accord side curtain airbag deployment test results

Side curtain airbag-related passenger injury test performed following the evaluation method proposed by the Technical Working Group (TWG) in North America.

- Test conditions
 - Dummy used:** Hybrid III 6-Year-Old Child Dummy
 - Test Mode:** Inboard Facing Hybrid III 6-Year-Old Child Dummy on Booster Block (Passenger Positions with Roof-Rail-Mounted Airbags, First Row)
 - TWG Test:** 3.3.5.1

- Injury degree results

Items	Criteria values	Results
HIC (Head Injury Criteria)	Below 723	9.1
Nij (Neck Injury Criteria)	Below 1.0	0.43
Neck Tension [N]	Below 1490	62.7
Neck Compression [N]	Below 1820	713.0

- Image before/after test

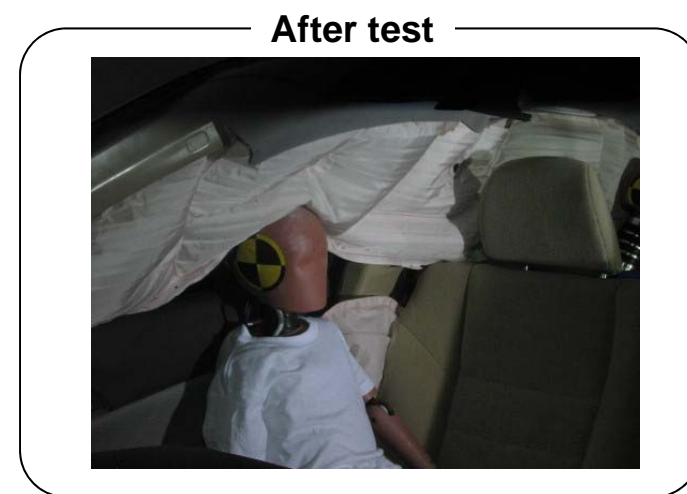
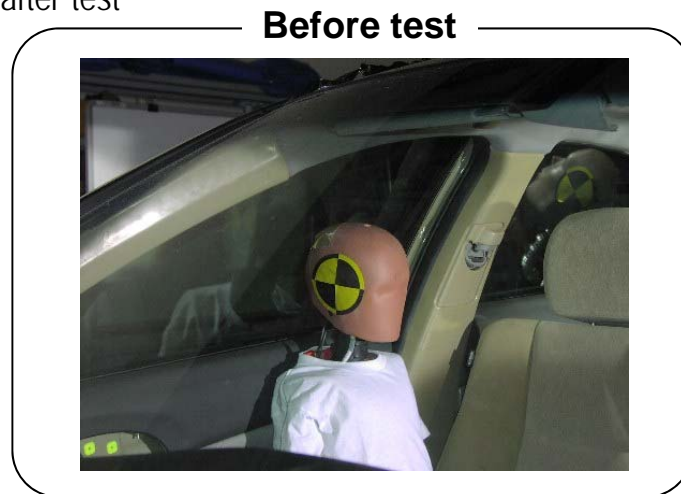

The results fall far below the criteria values with no serious injury to passengers.

North America 08M Accord side curtain airbag deployment test results

Side curtain airbag-related passenger injury test performed following the evaluation method proposed by the Technical Working Group (TWG) in North America.

- Test conditions
 - Dummy used:** Hybrid III 6-Year-Old Child Dummy
 - Test Mode:** Inboard Facing Hybrid III 6-Year-Old Child Dummy on Booster Block (Passenger Positions with Roof-Rail-Mounted Airbags, Second Row)
 - TWG Test:** 3.3.5.1

- Injury degree results

Items	Criteria values	Results
HIC (Head Injury Criteria)	Below 723	0.6
Nij (Neck Injury Criteria)	Below 1.0	0.24
Neck Tension [N]	Below 1490	9.3
Neck Compression [N]	Below 1820	405.9

- Image before/after test

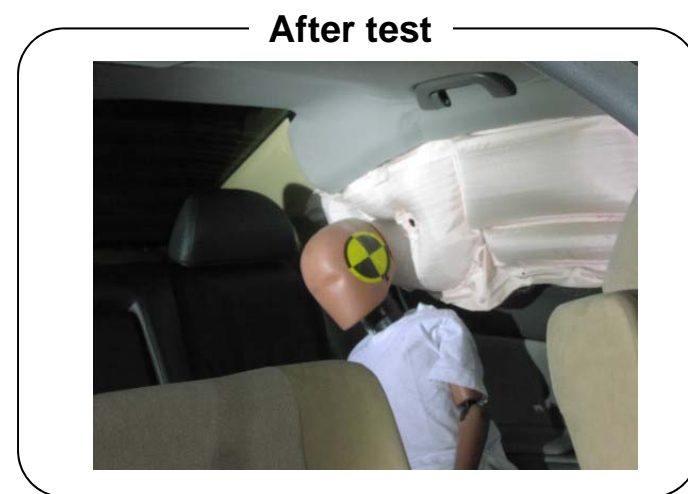
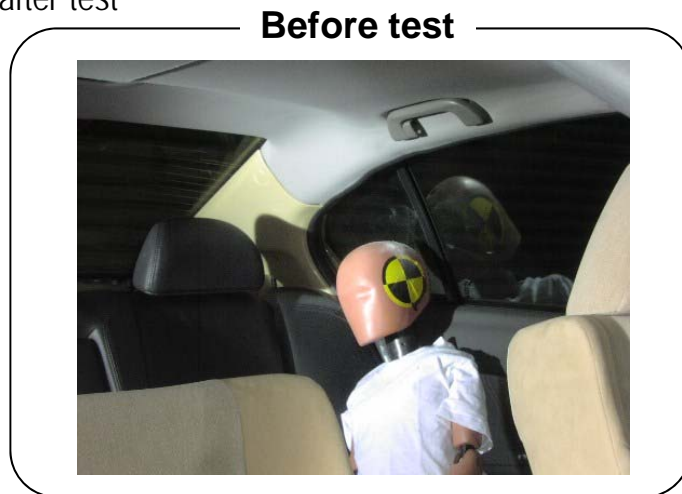

The results fall far below the criteria values with no serious injury to passengers.

08M Accord SCAB ~ Head Clearance

SCAB Shape

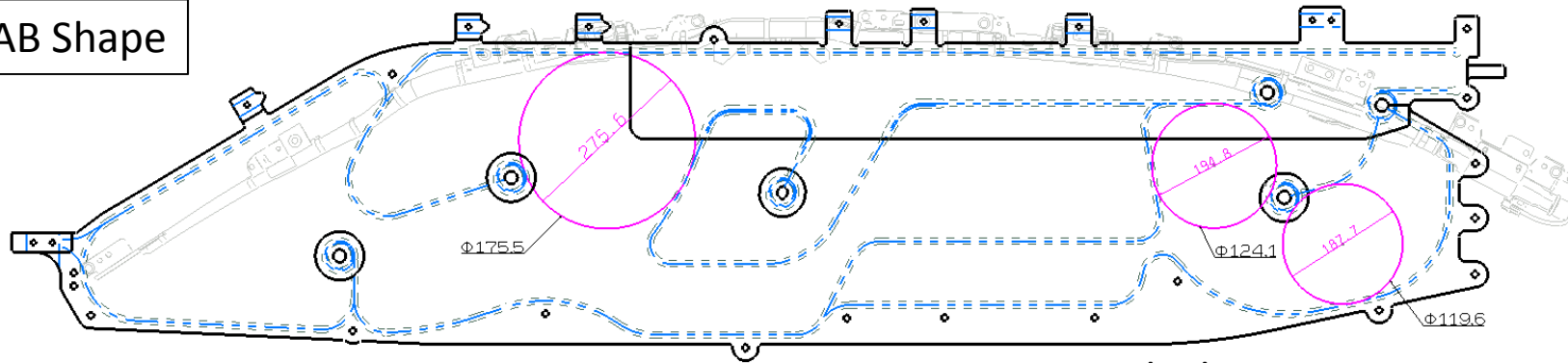

FR Seat Max Thickness = 175.5mm

Front seat is adjusted in the middle of its movable positions.



Before SCAB Deployment

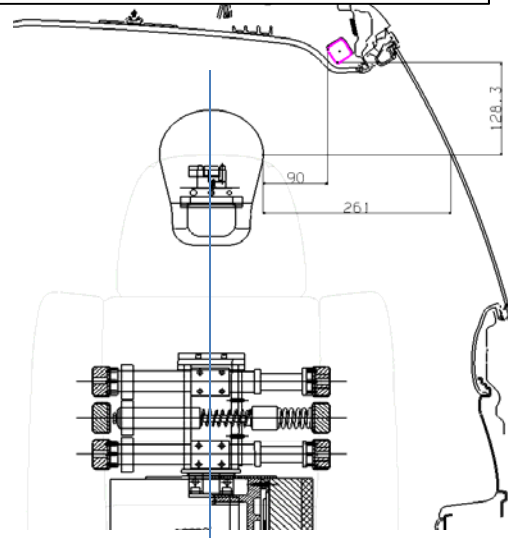

AM50% dummy seated aligned to the center of the seat.

After SCAB Deployment

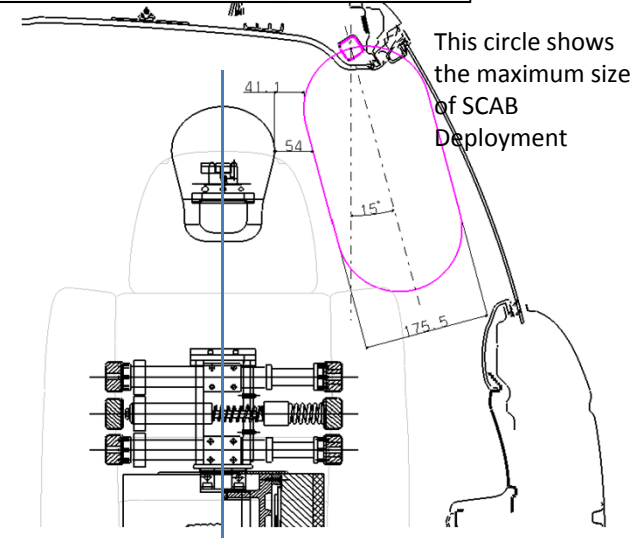

FR Seat Max Thickness = 175.5mm

Even with Max FR seat thickness, clearance between passenger head area is still ensured

08M Accord SCAB ~ Head Clearance

SCAB Shape

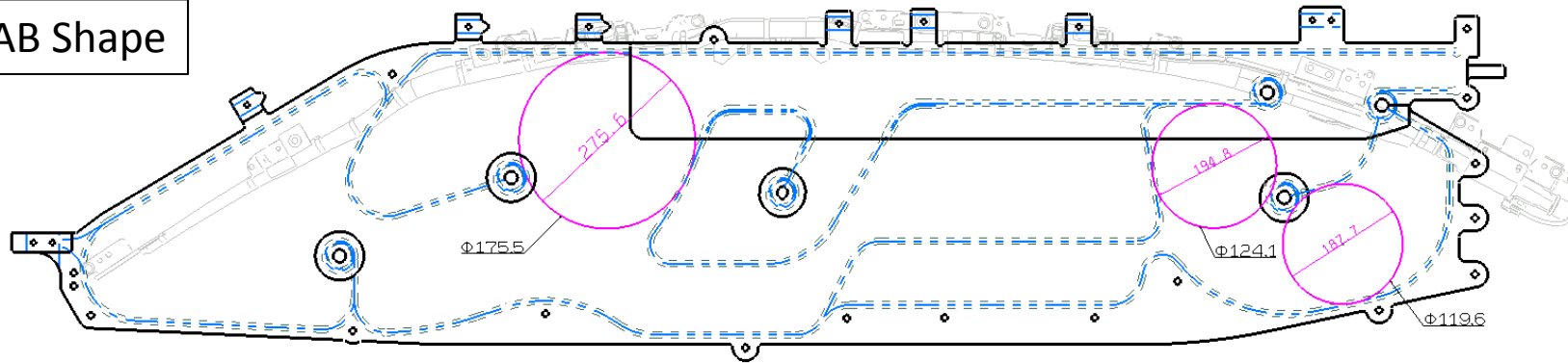

RR Seat Max Thickness = 124.1mm

Seat position of rear seat is fixed.
Head position is not moved.



AM50% dummy seated aligned to the center of the seat.

Before SCAB Deployment

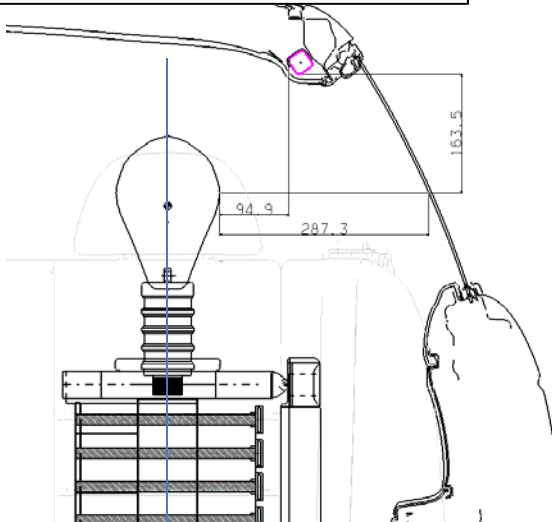

AF50% dummy seated aligned to the center of the seat.

After SCAB Deployment

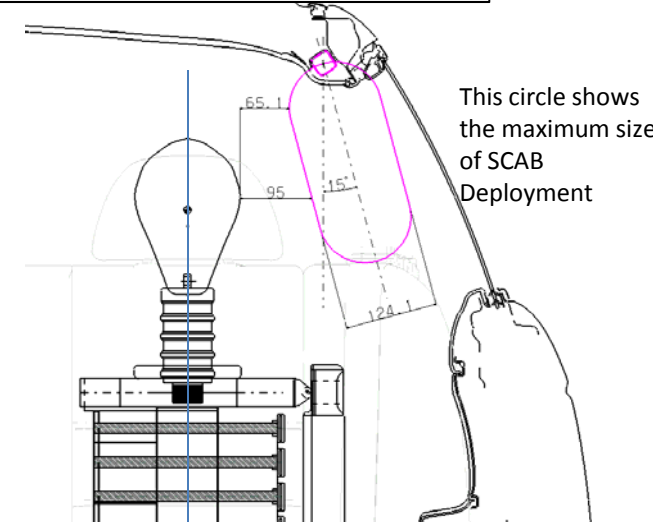

RR Seat Max Thickness = 124.1mm

Even with Max RR seat thickness, clearance between passenger head area is still ensured

SCAB Deployment



Under normal seating positions, SCAB does not contact passengers