

AQ14-003

CHRYSLER

12/12/2014

ENCLOSURE 17

CUSTOMER COMPLAINTS

FINALBACKUP

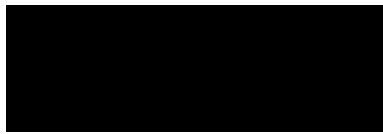

Document Recieved from Customer

Cair Number: [REDACTED]

Date Received: 2014-06-09 20:07:18.393438

Files Not Recieved: 0



BOB'S BODY SHOP

669 West Broad Street
COOKEVILLE, TENNESSEE 38501
(931) 528-5671 FAX (931) 528-2119
TN WATS 1-800-262-6625
US WATS 1-800-476-8501

Attn: Ashleigh

Case# [REDACTED]

AH1270

CUSTOMER'S ORDER NO.		PHONE		DATE <u>5-28-14</u>		
NAME [REDACTED]		SAC Transport Baxter TN Stan Cowan				
ADDRESS [REDACTED]						
SOLD BY	CASH	C.O.D.	CHARGE <input checked="" type="checkbox"/>	ON ACCT.	ROSE. RET'D.	PAID OUT
QTY.	DESCRIPTION			PRICE	AMOUNT	
	Tax Bill on 2011 Dodge			300		
	from Indian Creek Rd Bristol			200		
	to Bill Joruff Sparks					
Check # 9854 CUST PAID						
RECEIVED BY [REDACTED]					TAX	
					TOTAL	200 ⁰⁰

C PRODUCT #10
40785

by this bill.

Thank You

Document Recieved from Customer

Cair Number: [REDACTED]

Date Received: 2014-06-20 14:23:42.356020

Files Not Recieved: 0

Document Recieved from Customer

Cair Number: [REDACTED]

Date Received: 2014-06-17 16:08:38.606722

Files Not Recieved: 0

have pic on damages



BILL BORUFF AUTOMOTIVE, LLC

120 AUTO LANE • SPARTA, TN 38583

931-738-9275

Fax 931-738-9274

Fax number: 1-801-736-3229

To: AH 1270

From: 

Date: 17 June 2014 Dealer code 45261

Phone: 

Reference: 

Number of pages: 10 pages

Messages:

Please call have any questions



We are the Friendliest Dealership on Earth!

This facsimile and any attachments contain information which may be privileged. If you are not the intended recipient, please refrain from disclosure, copying, distribution or use of this information. Please beware that such actions are prohibited. If you have received this transmission in error, kindly notify us by resending this facsimile to 931-738-9274 and destroying all copies that you received in error. We appreciate your cooperation.

513663

82125

BILL BORUFF
AUTOMOTIVE LLC

WARRANTY

Hwy. 111 So., 120 Auto Lane
Sparta, Tennessee 38583
(931) 738-9275
Fax (931) 738-9274
Service Direct: (931) 739-1000

BAXTER, TN
HOME: [REDACTED] BUS:

PAGE 1

SERVICE ADVISOR: 6507 DANNY DODSON

COLOR	YEAR	MAKE/MODEL	VIN	LICENSE	MILEAGE IN	TAG	
BLK	11	DODGE D3500 TRUCK	3D73Y4C10BG [REDACTED]		62862/62862	T111	
DEL DATE	PROD. DATE	WARR. EXP.	PROMISED	PO NO.	RATE	PAYMENT	INV DATE
01JAN11 IS			17:00 28MAY14		72.00	CASH	17JUN14
R.C. OPENED		READY		OPTIONS: DLR: 45261 ENG: 6.7 Liter			

11:44 28MAY14 13:11 17JUN14

LINE OPCODE TECH TYPE HOURS LIST NET TOTAL

A CUSTOMERS VEHICLE TOWED IN. BALL JOINT IS BROKEN AND THERE IS DAMAGE ON THE PASS SIDE OF THE VEHICLE

CAUSE: REPAIR TRUCK TIE ROD BROKEN AND IN WRECK

19N49182 PERFORM RECALL N49

8415 RANDOLPH, RONNIE LIC#: 8415

WS 1.10

1	CBUEN491AC PACKAGE	147.00	122.99	122.99
1	CBUEN492AA NUT	0.75	0.63	0.63
1	68080207AD LINE-POWER STEERING PRESSURE	55.10	46.27	46.27
1	68218064AA *FLUID-POWERSTEERING	8.10	6.79	6.79
1	52122190AB HUB-BRAKE	384.00	322.00	322.00
1	5154661AC *DAMPER-STEERING	119.00	99.68	99.68

FC: RC

PART#: CBUEN491AC

COUNT: 1

CLAIM TYPE: S

AUTH CODE:

0200005Z ALINEMENT

8415 RANDOLPH, RONNIE LIC#: 8415

WS 0.80

FC: PART#: COUNT: 56.26 56.26

CLAIM TYPE: S

AUTH CODE:

05211009 Disc, Rotor Brake - Replace - Replace

Front - Left (2 - Skilled)

8415 RANDOLPH, RONNIE LIC#: 8415

WS 0.30

FC: PART#: COUNT: 21.10 21.10

CLAIM TYPE: S

AUTH CODE:

1985035Z DAMPER

DISCLAIMER OF WARRANTIES
Any warranties on the product sold hereby are those made by the manufacturer. The seller hereby expressly disclaims all warranties, either express or implied, including any implied warranty of merchantability or fitness for a particular purpose, and the seller neither assumes nor authorizes any other person to assume for it any liability in connection with the sale of said products. Any limitation contained herein does not apply where prohibited by law.

I hereby authorize the repair work to be done along with the necessary material and hereby grant you and/or your employees permission to operate the vehicle herein described on streets, highways or elsewhere for the purpose of testing and/or inspection. An express mechanic's lien is hereby acknowledged on above vehicle to secure the amount of repairs thereto. Dealer not responsible for unavailability of parts or delays in parts shipments beyond dealers control.

X

DESCRIPTION	TOTALS
LABOR AMOUNT	
PARTS AMOUNT	
GAS, OIL, LUBE	
SUBLET AMOUNT	
OTHER LABOR & MATERIALS	
TOTAL CHARGES	
LESS INSURANCE/DISCOUNTS	
SALES TAX	
PLEASE PAY THIS AMOUNT	

513663

82125

BILL BORUFF
 AUTOMOTIVE LLC.

 Hwy. 111 So., 120 Auto Lane
 Sparta, Tennessee 38583
 (931) 738-9275
 Fax (931) 738-9274
 Service Direct: (931) 739-1000

WARRANTY

PAGE 2

BAXTER, TN

HOME:

BUS:

SERVICE ADVISOR: 6507 DANNY DODSON

COLOR	YEAR	MAKE/MODEL	VIN	LICENSE	MILEAGE IN	TAG	
BLK	11	DODGE D3500 TRUCK	3D73Y4C10BG		62862/62862	T111	
DEL. DATE	PROD. DATE	WARR. EXP.	PROMISED	PO. NO.	RATE	PAYMENT	INV. DATE
01JAN11 IS			17:00 28MAY14		72.00	CASH	17JUN14
R.O. OPENED	READY	OPTIONS: DLR: 45261 ENG: 6.7 Liter					

11:44 28MAY14 13:11 17JUN14

LINE	OPCODE	TECH	TYPE	HOURS	LIST	NET	TOTAL
		8415	RANDOLPH, RONNIE	LIC#: 8415			
		WS	0.30			21.10	21.10
		FC: PART#: COUNT:					
		CLAIM TYPE: S					
		AUTH CODE:					

 22400240 Wheel Balance - Balance Front - Both -
 Excludes dual rear wheel equipped vehicles
 (0 - Low Skilled)

8415 RANDOLPH, RONNIE LIC#: 8415

WS 0.30

21.10 21.10

FC: PART#: COUNT:

CLAIM TYPE: S

AUTH CODE:

2243015Z TIRE

8415 RANDOLPH, RONNIE LIC#: 8415

WS 0.40

28.13 28.13

FC: PART#: COUNT:

CLAIM TYPE: S

AUTH CODE:

 23601402 Vehicle, one side complete - Color coat
 Right-Monotone

8174 HAWKINS, ROBERT LIC#: 8174

WS 0.00

0.00 0.00

FC: PART#: COUNT:

CLAIM TYPE: S

AUTH CODE:

23602101 Panel, hood - Color coat Hood-Monotone

8174 HAWKINS, ROBERT LIC#: 8174

WS 0.00

0.00 0.00

FC: PART#: COUNT:

DISCLAIMER OF WARRANTIES

Any warranties on the product sold hereby are those made by the manufacturer. The seller hereby expressly disclaims all warranties, either express or implied, including any implied warranty of merchantability or fitness for a particular purpose, and the seller neither assumes nor authorizes any other person to assume for it any liability in connection with the sale of said products. Any limitation contained herein does not apply where prohibited by law.

I hereby authorize the repair work to be done along with the necessary material and hereby grant you and/or your employees permission to operate the vehicle herein described on streets, highways or elsewhere for the purpose of testing and/or inspection. An express mechanic's lien is hereby acknowledged on above vehicle to secure the amount of repairs thereto. Dealer not responsible for unavailability of parts or delays in parts shipments beyond dealer's control.

X

DESCRIPTION	TOTALS
LABOR AMOUNT	
PARTS AMOUNT	
GAS, OIL, LUBE	
SUBLET AMOUNT	
OTHER LABOR & MATERIALS	
TOTAL CHARGES	
LESS INSURANCE/DCOUNTS	
SALES TAX	
PLEASE PAY THIS AMOUNT	

513663

82125

BILL BORUFF
AUTOMOTIVE LLC.

Hwy. 111 So., 120 Auto Lane
Sparta, Tennessee 38583
(931) 738-9275
Fax (931) 738-9274
Service Direct: (931) 739-1000

WARRANTY

PAGE 4

BAXTER, TN
HOME: [REDACTED] BUS:

SERVICE ADVISOR: 6507 DANNY DODSON

COLOR	YEAR	MAKE/MODEL	VIN	LICENSE	MILEAGE IN	TAG	
BLK	11	DODGE D3500 TRUCK	3D73Y4CLOBC [REDACTED]		62862/62862	T111	
DEL. DATE	PROD. DATE	WARR. EXP.	PROMISED	PO. NO.	RATE	PAYMENT	INV. DATE
01JAN11 IS			17:00 28MAY14		72.00	CASH	17JUN14
R.O. OPENED		READY	OPTIONS: DLR:45261 ENG:6.7 Liter				

11:44 28MAY14 13:11 17JUN14

LINE	OPCODE	TECH	TYPE	HOURS	LIST	NET	TOTAL
------	--------	------	------	-------	------	-----	-------

WE ARE NOT RESPONSIBLE FOR ARTICLES LEFT IN VEHICLES.
PARTS WARRANTY IS 12 MO. OR 12000 MILES WHICH EVER COMES FIRST CHRY PARTS ONLY
THANK YOU FOR YOUR BUSINESS
WE CARE!!!!
LABOR RATE 70.00 PERFLAT RATE

COST, SALE, & COMP TOTALS 662355 592296 0

DISCLAIMER OF WARRANTIES
Any warranties on the product sold hereby are those made by the manufacturer. The seller hereby expressly disclaims all warranties, either express or implied, including any implied warranty of merchantability or fitness for a particular purpose, and the seller neither assumes nor authorizes any other person to assume for it any liability in connection with the sale of said products. Any limitations contained herein does not apply where prohibited by law.

I hereby authorize the repair work to be done along with the necessary material and hereby grant you and/or your employees permission to operate the vehicle herein described on streets, highways or elsewhere for the purpose of testing and/or inspection. An express mechanic's lien is hereby acknowledged on above vehicle to secure the amount of repairs thereto. Dealer not responsible for unavailability of parts or delays in parts shipments beyond dealers control.

X _____

DESCRIPTION	TOTALS
LABOR AMOUNT	225.05
PARTS AMOUNT	598.36
GAS, OIL, LUBE	0.00
SUBLET AMOUNT	6099.55
OTHER LABOR & MATERIALS	0.00
TOTAL CHARGES	6922.96
LESS INSURANCE/DISCOUNTS	0.00
SALES TAX	0.00
PLEASE PAY THIS AMOUNT	6922.96

JEFF'S BODY SHOP
740 FRED HILL RD, SPARTA, TN 38583
Phone: (931) 738-7820

Workfile ID: c4b03c4
Federal ID: 62-1280793
State ID: 0306-4869
Resale Number: 100840182

Preliminary Estimate

Customer: [REDACTED] **Job Number:** [REDACTED]

Written By: Jeff Young

Insured: [REDACTED] Policy #: [REDACTED] Claim #: [REDACTED]

Type of Loss: [REDACTED] Date of Loss: [REDACTED] Days to Repair: 0
Point of Impact: [REDACTED]

Owner: [REDACTED] **Inspection Location:** JEFF'S BODY SHOP
TRANSPORT 740 FRED HILL RD
BAXTER, TN SPARTA, TN 38583
Repair Facility
(931) 738-7820 Business **Insurance Company:**

VEHICLE

Year: 2011 Body Style: 4D LONG VIN: 3D73Y4CL0BG [REDACTED] Mileage In:
Make: DODG Engine: 6-6.7L-TD License: [REDACTED] Mileage Out:
Model: RAM 3500 4X4 CREW Production Date: [REDACTED] State: [REDACTED] Vehicle Out:
LARAMIE
Color: BLACK MET Int: Condition: Job #:

TRANSMISSION

Overdrive
6 Speed Transmission
4 Wheel Drive

POWER

Power Steering
Power Brakes
Power Windows
Power Locks
Power Mirrors
Heated Mirrors
Power Driver Seat
Power Passenger Seat
Memory Package

DECOR

Dual Mirrors

Tinted Glass

Wood Interior Trim

CONVENIENCE

Air Conditioning
Intermittent Wipers
Tilt Wheel
Cruise Control
Keyless Entry
Alarm
Message Center
Steering Wheel Touch Controls
Climate Control
Parking Sensors
Home Link

RADIO

AM Radio

FM Radio

Stereo

Search/Seek

CD Player

Auxiliary Audio Connection

Satellite Radio

SAFETY

Drivers Side Air Bag
Passenger Air Bag
Anti-Lock Brakes (4)
4 Wheel Disc Brakes
Front Side Impact Air Bags
Head/Curtain Air Bags
Hands Free Device
Positraction

SEATS

Leather Seats

Heated Seats

WHEELS

Aluminum/Alloy Wheels

PAINT

Clear Coat Paint

OTHER

Fog Lamps
Signal Integrated Mirrors

TRUCK

Rear Step Bumper
Power Rear Window
Trailer Hitch
Trailer Package
Dual Rear Wheels

Preliminary Estimate

Customer: [REDACTED]

Job Number:

Vehicle: 2011 DODG RAM 3500 4X4 CREW LARAMIE 4D LONG 6-6.7L-TD BLACK MET

Line	Oper	Description	Part Number	Qty	Extended Price \$	Labor	Paint
1		FRONT LAMPS					
2	R&I	RT R&I headlamp assy				0.4	
3	Repl	RT Fog lamp	55372734AB	1	79.50	0.3	
4		FRONT BUMPER					
5		O/H front bumper				2.2	
6	Repl	Bumper chrome w/fog lamps	68045698AB	1	394.00	Ind.	
7		Add for fog lamps				0.4	
8	Repl	Air deflector 4WD	68045708AA	1	106.00	Ind.	
9	#	R&I RT HEADLAMP FILLER				0.4	
10	Repl	RT Upper bracket	68064330AA	1	41.60		
11	Repl	RT Lamp bracket fog	68054374AB	1	44.45		
12	Repl	RT Support bracket	68064329AB	1	41.60		
13	Repl	RT Filler molding paintable	1HH70TZZAC	1	67.45	Ind.	0.6
14	#	Repl RT FILLER SUPPORT BRACKET		1	27.25		
15		FENDER					
16	Repl	RT Fender	68054338AF	1	179.00	2.3	2.6
17		Add for Clear Coat					1.0
18		Add for Edging					0.5
19		Add for Clear Coat					0.1
20	*	Repl Nameplate CJMMINS TURBO DIESEL	55078116AA	1	52.35	0.3	
21	Repl	RT Fender liner 4WD	55372888AG	1	107.00	Ind.	
22		HOOD					
23	Blnd	Hood (ALU)					1.6
24		WINDSHIELD					
25	R&I	RT Washer nozzle				0.2	
26	R&I	LT Washer nozzle				0.2	
27		FRONT DOOR					
28	Blnd	RT Door shell crew, mega cab					1.9
29	R&I	RT Belt w'strip crew, mega cab				0.3	
30	*	Repl RT Nameplate RAM 3500 HEAVY DUTY	55372159AC	1	70.35	0.4	
31	R&I	RT Mirror assy w/power, heated w/o memory pkg(GUK)				0.3	
32	R&I	RT Handle, outside w/o body color & black w/keyless entry				0.3	
33	R&I	RT R&I trim panel				0.5	
34		REAR DOOR					
35	*	Rpr RT Door shell				1.0	2.4
36		Overlap Major Non-Adj. Panel					-0.2
37		Add for Clear Coat					0.4
38	R&I	RT Belt w'strip				0.3	
39	R&I	RT Handle, outside w/o body				0.3	

Preliminary Estimate

Customer:							Job Number:	
Vehicle: 2011 DODG RAM 3500 4X4 CREW LARAMIE 4D LONG 6-6.7L-TD BLACK MET								
		color black						
40	R&I	RT R&I trim panel				0.3		
41	#	Rpr RIGHT OUTER ROCKER PANEL				7.5	2.1	
42		Add for Clear Coat					0.4	
43	#	Rpr RIGHT INNER ROCKER PANEL FOR STEP BOARD MOUNTS				4.5	0.5	
44	CAB							
45	Repl	Running board MOPAR, aluminum	82211496AF	1	653.00	1.4		
46	WHEELS							
47	*	Repl RT/Front Wheel, steel 17x6 (WFLU)	ZZ23S4AAC	1	202.00	m	0.3	
48	*	Repl RT/Front Center cap type 2, front 17x6 steel (WD4)	52106877AB	1	110.00			
49		Repl RT/Front Wheel cover 17x6 steel (WD4) front	52106937AB	1	87.45			
50	#	Repl LT 235/80R17 FRONT TIRES		2	490.00			
51	#	MOUNT & BALANCE WHEEL		3	45.00			
52	#	MOUNTING AND BALANCE INCLUDES BOTH FRONTS AND RIGHT REAR		1				
53	#	RUST CORROSION PROTECTION		1	10.00	T		
54	#	HAZARDOUS WASTE DISPOSAL		1	4.00	T		
55	#	COVER CAR FOR OVERSPRAY		1	1.00	T	0.2	
56	PICK UP BOX							
57	Repl	RT Rail cover	55372204AE	1	67.50		0.4	
58	Repl	Tail gate	68105727AC	1	544.00		1.6	3.4
59		Overlap Major Non-Adj. Panel					-0.2	
60		Add for Clear Coat					0.6	
61	*	Repl Spoiler	55372052AG	1	61.35		0.3	
62		Repl Nameplate "4x4"	55277438AA	1	52.00		0.2	
63	*	R&I Nameplate "BIG HORN"					0.6	
64	*	R&I Emblem					0.4	
65	Repl	LT Rail cover	55372205AE	1	67.50		0.4	
				SUBTOTALS	3,605.35	28.2	17.7	

Preliminary Estimate

Customer: [REDACTED]

Job Number:

Vehicle: 2011 DODG RAM 3500 4X4 CREW LARAMIE 4D LONG 6-6.7L-TD BLACK MET

ESTIMATE TOTALS

Category	Basis	Rate	Cost \$
Parts			3,590.35
Body Labor	28.2 hrs @	\$ 42.00 /hr	1,184.40
Paint Labor	17.7 hrs @	\$ 42.00 /hr	743.40
Paint Supplies	17.7 hrs @	\$ 32.00 /hr	566.40
Miscellaneous			15.00
Subtotal			6,099.55
Grand Total			6,099.55
Deductible			0.00
CUSTOMER PAY			0.00
INSURANCE PAY			6,099.55

[REDACTED]

IT IS A CRIME TO KNOWINGLY PROVIDE FALSE, INCOMPLETE OR MISLEADING INFORMATION TO AN INSURANCE COMPANY FOR THE PURPOSE OF DEFRAUDING THE COMPANY. PENALTIES INCLUDE IMPRISONMENT, FINES AND DENIAL OF INSURANCE BENEFITS.



[Redacted]

PO: 52352
PAGE: 1 OF 1
PO DATE: 17JUN2014
PRINT DATE: 17JUN2014 13:10
TELEPHONE: [Redacted]
REQUESTOR: RH
ISSUED BY: RH
SHIP VIA: [Redacted]

724
JEFF'S BODY SHOP

740 FRED HILL ROAD
SPARTA TN 38583

ORDER AMOUNT: \$6,099.55

RO NO.	DESCRIPTION	AMOUNT
82125	BODY REPAIR	6099.55
CUSTOMER#: 513663		
NAME: [Redacted]		

INVOICE: 15777
DATE: 17JUN2014
AMOUNT: 6099.55

STATUS: APPROVED
COMMENT:

CO	ACCOUNT	DESCRIPTION	AMOUNT	CONTROL	CONTROL2
2	13603	INV-SUBLET WORK	6099.55		

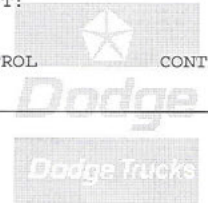
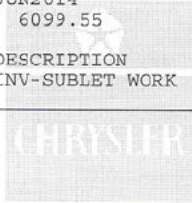

PURCHASE ORDER

VENDOR COPY

AQ14-003

CHRYSLER

12/12/2014

ENCLOSURE 17

CUSTOMER COMPLAINTS

FINALBACKUP

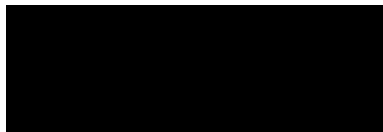

RECEIVED DATE:

05/21/14

POSTED DATE :

5-13-14

VIN (FIRST 9 DIGITS)

3D7KS29C6

VIN (LAST 8 DIGITS)

7G



FIRST NAME:

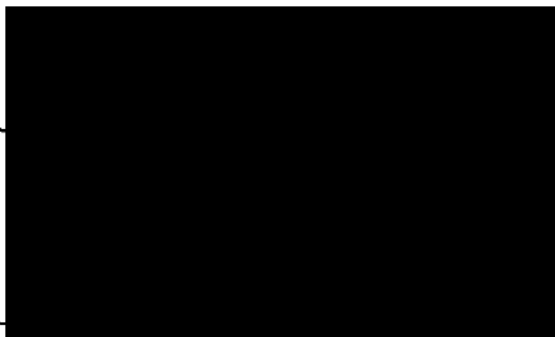

LAST NAME :

CAIR :

0 0 0 0 0 0 0 0

NON - SCANABLE ITEMS : CIRCLE ONE

NO

YES



CHRYSLER

Left Tie Rod

IMPORTANT SAFETY RECALL N62/NHTSA 13V-528

This notice applies to your vehicle (VIN: 3D7KS29C67G [REDACTED]).

This notice is sent to you in accordance with the requirements of the National Traffic and Motor Vehicle Safety Act.

Dear [REDACTED]

Chrysler has decided that a defect, which relates to motor vehicle safety, exists in some 2003 through 2008 model year Dodge RAM 1500/2500/3500 series Trucks that had the steering linkage replaced with MOPAR service parts.

The problem is... The left tie rod ball stud on your truck may fracture under certain driving conditions. This could cause a loss of directional control and/or crash without warning.

What your dealer will do... Chrysler will repair your vehicle free of charge (parts and labor). To do this, your dealer will inspect the steering linkage on your truck and replace steering linkage component(s) if required. The inspection will take less than ½ hour. If linkage replacement is required, the work will take an additional 1 hour to complete. However, additional time may be necessary depending on service schedules.

What you must do to ensure your safety... Simply contact your Chrysler, Jeep, or Dodge dealer starting January 6, 2014 to schedule a service appointment. Ask the dealer to hold the parts for your vehicle or to order them before your appointment. Please bring this letter with you to your dealer.

If you need help... If you have questions or concerns which your dealer is unable to resolve, please contact the Chrysler Group Recall Assistance Center at 1-800-853-1403.

Please help us update our records by filling out the attached prepaid postcard if any of the conditions listed on the card apply to you or your vehicle. You may also update this information on the web at www.dodge.com/ownersreg.

If you have already experienced this condition and have paid to have it repaired, please send your original receipts and/or other adequate proof of payment to the following address for reimbursement: Chrysler Customer Assistance, P.O. Box 21-8007, Auburn Hills, MI 48321-8007, Attention: Reimbursement. Once we receive and verify the required documents, reimbursement will be sent to you within 60 days.

If your dealer fails or is unable to remedy this defect without charge and within a reasonable time, you may submit a written complaint to the Administrator, National Highway Traffic Safety Administration, 1200 New Jersey Ave., S.E., Washington, DC 20590, or call the toll-free Vehicle Safety Hotline at 1-888-327-4236 (TTY 1-800-424-9153), or go to <http://www.safercar.gov>.

Vehicle information Year: 2007 Make: DODGE-RAM TRUCK
 Model: RAM 2500 PICKUP Color:
 License: (M) Odometer: 195,144
 Engine: 6-360 5.9L Dsl VIN: 3D7KS29C67G
 Unit: Driver:
 Tire Pressure Front: 0 Rear: 0 Torque:

Cust.:
 Address: LAS VEGAS, NM
 City, State, Zip: LAS VEGAS, NM
 Home: Work: Cell:
 Bill To:

Customer Instructions Save Old Parts? No

Part No.	Description	Technician	Qty	Unit Price	Total Price
	PRECISION ALIGNMENT		0.00		
LAB ALL	WHEEL ALIGNMENT		1.00	59.99	59.99
	*WARRANTY ALIGNMENT 30 DAY		0.00	0.00	0.00

Invoice Summary

	Payment		Invoice Totals	
	Type	Amount		
	CASH	\$70.04	Parts	0.00
			FET	0.00
			Core Chg	0.00
			Labor	59.99
			Waste Disposal	0.00
			Shop Supplies	4.80
			Sales Tax	5.25
			Total:	70.04

I have received the above goods and/or services. If this is a credit card purchase, I agree to pay and comply with the cardholders agreement with the issuer. There are no cancellations allowed.

Customer Signature _____

(Version: bolasin9 - 20130918)

Sales Tax (8.0625%)	\$65.53
Total	\$878.36

THE PIT STOP
 803 GRAND AVE
 LAS VEGAS, NM 87701

Estimate

Date	Estimate #
3/10/2014	476

Name / Address
Cash Sale

			Project
Description	Qty	Rate	Total
Labor tie rod ends and 4 wheel U joint	8	70.00	560.00
tie rod end	1	37.60	37.60
road side charge	1	200.00	200.00
U joint	1	15.23	15.23
		Subtotal	\$812.83
		Sales Tax (8.0625%)	\$65.53
		Total	\$878.36

Romero's Automotive Tire & Muffler Center

P.o. Box 554: 215 South Grand Ave.

Las Vegas, NM 87701

505-425-9412

"Let Us Do It Right The First Time"

Invoice #2353
P.O. #

estimate

(505) _____ (505) _____
tag: Mileage:
ID

Labor

Labor to repair exhaust pipe \$60.00
\$15

Subtotal \$75.00
Shop Supplies
Subtotal \$75.00
Tax \$6.12
Total \$81.12

***** Thank You For Your Business *****

DATE _____ PHONE _____

*Tail pipe & Muffler damage
Road crash -*



OFFICE P.O. BOX 1156 SPRINGFIELD, MO 65801
PHONE (417) 863-3333



STORE PHONE # 505 426-8620
ADDRESS: 2514 7TH STREET
LBS VETS INC 67701-4990
REMIT TO: PO BOX 9464
SPRINGFIELD MO 65801-9464

BILL TO 9929936 SHIP TO

THANKS FOR YOUR BUSINESS
AND FOR BEING AN
O'REILLY MEMBER

INVOICE NUMBER
INVOICE DATE
CASH SALE

COMPUTER SERIAL INSTRUCTIONS SHIP VIA CUSTOMER ORDER NO. TIME OF ORDER PAID (CHECKED BY)

TAX 2	QTY	LINE	ITEM NUMBER	UNIT	QTY	DESCRIPTION	UNIT PRICE	AMOUNT	TAX	NET	DISC	CODE	EXTENDED
	1		1 MFC DS1463	EA	1	JTE MOD END	38.97	38.97		22.99			22.99
	1		1 MFC DS1463	EA	1	LIMITED LIFETIME WARRANTY							
	1		1 MFC DS1463	EA	1	LIMITED LIFETIME WARRANTY	64.39	64.39		37.99			37.99
TOTALS													

CUSTOMER SIGNATURE

ALL MERCHANDISE RETURNED MUST BE ACCOMPANIED BY THIS INVOICE

Visit Us At: www.oreillyauto.com

103.36 SUB-TOTAL 60.98
CASH TEND 65.00 TAX/FEE 4.92
TOTAL 65.90

To Whom it may Concern;

My Name is [REDACTED] I own a 2006 Dodge Ram 2500 Mega Cab 4x4 Cummins VIN: 3D7KS29C676 [REDACTED]

I have 198,000 miles on it, I bought it brand new Fall 2006. Since 1994 I have owned 6-7 all of the Cummins but I'm in 1998. I have had several maintenance issues & them mainly in the drive line 4x4 u-joints, Cardigan u-joint, drive line u-joints back to front Power Steering hose output & Return, Automatic transmission Repair. On this latest 06 model u-joints have been a frequent problem. I realize that these are wear & tear issues but not this frequent.

At about 12,000 miles I took it in to the Las Vegas dealership for inspection/repair. They could not find the problem, so I had to accept the problem. I spoke with the mechanic and he agreed that it was my imagination.

Recently at about 197,500 miles, I had an accident... The tie rod end came off as I was driving putting me in a roadside ditch. I had to call a mechanic for a roadside repair 12 miles from town. This was very costly but mostly scary and bothersome. I am thankful that my family wasn't with me or that it didn't involve another vehicle.

When I crashed I damaged the tie-rod, tie rod dampener shock, fractured the passenger side 4x4 u-joint, rt. outer u-joint play, broke the weld on the exhaust damaged the tailpipe. The mechanic suggested replacement of the other tie-rod end.

I reported this to the Santa Fe dealership, even took it in for a 5 minute inspection. They told me that this model truck was not the one in question & problems. I found out later that this truck was one of the recall. Can you please help me? Thank You [REDACTED]

home
cell

Las Vegas, N.M.

I know this alot, But

Can you please help me

to had to borrow money

to get back on the

Road

THANKS



Las Vegas, N.M.



DENVER CO 802

13 MAY 2014 PM 11 T

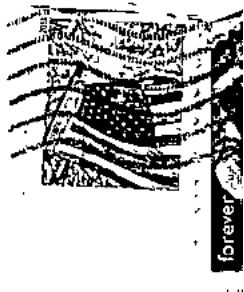
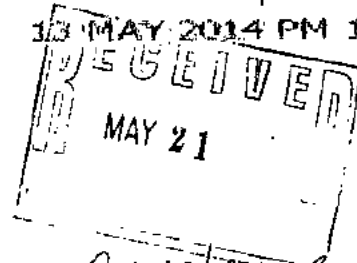

Chrysler Customer Assistance
P.O. Box 21-8007
Warren Hills, MI
48091-8007

Attention
Reimburs

480918007





August 5, 2014

[REDACTED]
Las Vegas, NM [REDACTED]

CAIR: [REDACTED]

Dear Mr. [REDACTED]

Thank you for your letter dated May 21, 2014.

Naturally, we were sorry to learn of the problem you experienced with your 2007 Dodge Ram, especially due to the inconvenience and expense.

Chrysler LLC has issued Recall N62 / Left Outer Tie Rod Assembly, which relates to some 2003 through 2008 Model year Dodge Ram 1500/2500/3500 series trucks that had the steering linkage replaced with Mopar service parts. The parts placed on the vehicle manufacture were/are not recalled. These parts would have been replaced, either under warranty, or at the customer's expense, previously, using Mopar replacement parts. These are parts being recalled.

So if you have had them replaced as stated above, you will need to send in that paid repair bill, so we can review. If you have not had those replaced at one time using Mopar service parts, they are not reimbursable.

Thank you for writing.

Sincerely,

M. Gentry
Special Investigations
586-274-8160

MG/sk

Phone 800.992.1997

Chrysler Group LLC | CIMS 484-04-04 | P.O. Box 21-8004 | Auburn Hills, MI USA | 48321

AQ14-003

CHRYSLER

12/12/2014

ENCLOSURE 17

CUSTOMER COMPLAINTS

FINALBACKUP

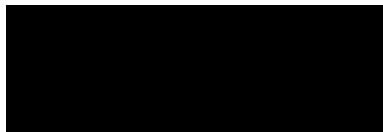

Document Recieved from Customer

Cair Number: [REDACTED]

Date Received: 2014-06-07 14:25:19.612740

Files Not Recieved: 0

Towing receipt attached as requested.

C & V Wrecker Service
PO Box 1376
Winnie TX 77665
409-296-9542 Fax: 409-296-4529

Date: 5-17-14
Driver: [REDACTED]
Customer Covered: _____

Name of Motor Club: _____

Member#: _____ Basic: _____ Plus: _____ Premier: _____

PO#: _____ Service Type: tow

Year: 10 Make: Dodge Model: 3500 Color: brown

State: TX VIN#: 3DT3Y4HL4A1 [REDACTED] LP#: [REDACTED]

Mileage: _____ Location: East Rd + Hwy 87, Post Bolivar

Name: All Pro Enterprises Callback#: _____

Address: Tomball Dodge City State: TX

Arrival Time: _____ am/pm Completion Time: _____ am/pm

Outbound Miles: _____ @ _____ \$

Hook Up: _____ \$ 600.00

Tow Miles: _____ @ _____ \$

Total Due: \$ 600.00

pd cash

Customer Paid: \$ 600.00

Balance Due: \$ 0

Signature: _____

Closed: _____ am/pm LIMA#: _____

Document Recieved from Customer

Cair Number: [REDACTED]

Date Received: 2014-07-17 11:12:35.090989

Files Not Recieved: 0

DISCOUNT TIRE

5530166

discounttire.com

DATE: 07-27-2014 TIME: 4:20 PM

INFORMATION	VEHICLE INFORMATION	STORE LOCATION
[REDACTED] SPRING (H) [REDACTED] TX [REDACTED]	2011 DODGE RAM 3500 DUALY 17"BASE BIGHORN MILEAGE: 107,187 TORQUE SPECS: 145	TX 33 7325 FM 1960 WEST HOUSTON TX 77070 PHONE: 281-580-1381 825 DAVID M BONE WORK ORDER# _____

CODE	CC	QTY	SIZE	DESCRIPTION	P.E.T.	PRICE	AMOUNT
12840	NRM	2	LT235/80R17E1 120R B	HAN DYNAPRO HT RH12 D6B	.00	147.00	294.00
WARRANTY: SEE REVERSE SIDE FOR WARRANTY DETAILS COMMENT: BOLT PATTERN: 6-165.1 COMMENT: INFLATION F:65 R:65							
80017	NRM	2	CERTIFICATES FOR	REFUND, REPLACEMENT	.00	23.00	46.00
80224	NRM	2	WASTE TIRE DISPOSAL	FEE	.00	2.50	5.00
80219	NRM	2	INSTALLATION &	LIFETIME SPIN BALANCING	.00	16.00	32.00
80402	NRM	2	VALVES/ROTATIONS/	LIFETIME REPAIRS INCLUDED	.00	.00	.00
91817	NRM	2	5600MP 500 TRUCK	MP TRUCK SCHRADER	.00	2.50	5.00
COMMENT: APPOINTMENT: 07-27-2014 12:00 PM							

Since you have purchased fewer than four tires (or wheels), we will mount the new tires on the rear of your vehicle for best safety and handling.

*Att: Luame
25088111*

SUBTOTAL: 382.00
 TAX: 25.08
 TOTAL: 407.08
 [REDACTED]: 407.08
 TENDERED: 407.08

XXXXXXXXXXXX [REDACTED]

Signature on file



AQ14-003

CHRYSLER

12/12/2014

ENCLOSURE 17

CUSTOMER COMPLAINTS

FINALBACKUP

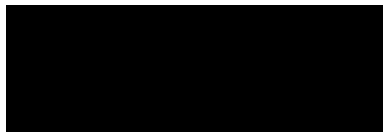

Attn: Case #

[REDACTED]

[REDACTED]

INVOICE
BIG O TIRES # 60092
 2727 CY AVENUE
 CASPER, WY 82604
 (307) 234-2446



Visit us on the web at: www.bigotires.com

Invoice No: [REDACTED] Page 1
 Order No: 95626
 Date: 06/04/2014 Time: 05:49 PM
 Started by: TERRY KANE
 Invoiced by: TERRY KANE

Vehicle Information Year: 2011 Make: DODGE-RAM TRUCK
 Model: RAM 3500 1 TON PICKUP Color:
 License: [REDACTED] (WY) Odometer: 35,407
 Engine: 6-408 6.7L Dsl VIN:
 Unit: Driver:
 Tire Pressure Front: 0 Rear: 0 Torque: 145
Customer Instructions Save Old Parts? No

Cust.: [REDACTED]
 Address: [REDACTED]
 City, State, Zip: CASPER, WY [REDACTED]
 Home: [REDACTED] Work: [REDACTED] Cell:
 Bill To:

Part No. Description

Part No.	Description	QTY	UNIT PRICE	TOTAL
COM NOTES	FRONT END INSPECTION	1.00	0.00	0.00
A 107200173	245/70R17 FIRESTONE TRANSFORCE A/T	1.00	200.00	200.00
	Tire Serial #: TBD			
LAB TICB	COMPUTER WHEEL BALANCE	1.00	0.00	0.00
	custom wheels and duallys must be re-torqued in 15 miles after installation and after every tire rotation. Big o tires Casper will not be responsible after 15 miles of wheels being put on or rotated if they are not properly torqued.			
	* THIS IS NOT A BIG O BRAND TIRE	0.00	0.00	0.00
	* THIS TIRE IS COVERED ONLY BY	0.00	0.00	0.00
	* MANUFACTURER'S WARRANTY	0.00	0.00	0.00
	* AGAINST MATERIALS DEFECTS	0.00	0.00	0.00
	* BIG O ROAD HAZARD WARRANTY	0.00	0.00	0.00
	* DOES NOT APPLY	0.00	0.00	0.00
FEE FEETD	TIRE DISPOSAL FEE	1.00	4.00	4.00
LAB ALCF	FREE ALIGNMENT CHECK	1.00	0.00	0.00
RHW TPP	TIRE PROTECTION PLAN	1.00	31.50	31.50

THESE TIRES HAVE ROAD HAZARD COVERAGE***FREE REPLACEMENT FOR THE FIRST THREE YEARS, THEREAFTER FOR THREE ADDITIONAL YEARS OR 3/32" OF TREAD WHICHEVER COMES FIRST A PRORATED WORKMANSHIP AND MATERIALS WARRANTY***FREE ROTATIONS***FREE FLAT REPAIRS***FREE RE-BALANCING***FREE ROADSIDE ASSISTANCE FOR THE USEABLE LIFE OF TIRE / 3 YEARS OR 3/32" OF TREAD. FOR ROADSIDE ASSISTANCE, PLEASE CALL 1-888-592-5068

N 288-3740	OUTER TIE ROD	3190	1.00	101.79	101.79
LAB FEL	FRONT END LABOR	3190	0.40	88.99	34.80
LAB AL3	LIGHT TRUCK & VAN ALIGNMENT	3533	1.00	79.99	79.99
DIS DISS	SERVICE DISCOUNT		1.00	-30.00	-30.00
COM NOTES	LEFT FRONT OUTER TIE ROD WAS SHEARED OFF		1.00	0.00	0.00
COM NOTES	UPON ARRIVAL. PUNCTURED LEFT FRONT TIRE		1.00	0.00	0.00

*** Technicians who Performed Services on Invoice ***

[] [3190] JOSEPH TOMLINSON
 [3533] ROBBIE BUELL

Invoice Summary

BIG O TIRES WILL NOT BE RESPONSIBLE FOR DAMAGE TO NON STEEL WHEELS AND DUALY WHEELS THAT ARE NOT RE-TORQUED AT 15 MILES AND 100 MILES. ALL ABOVE PURCHASED WARRANTIES REPLACE ALL OTHER WARRANTIES EXPRESSED OR IMPLIED. THANK YOU FOR YOUR BUSINESS.	Payment		Invoice Totals	
	Type	Amount		
	VS	\$468.98	Parts	301.79
			FET	0.00
			Core Chg	0.00
			Labor	118.29
			Waste Disposal	4.00
			Shop Supplies	23.32
			Sales Tax	23.58
			Total:	468.98

I have received the above goods and/or services. If this is a credit card purchase, I agree to pay and comply with the cardholders agreement with the issuer. There are no cancellations allowed.

Customer
 Signature _____

Attn: Case # [REDACTED]

[REDACTED]

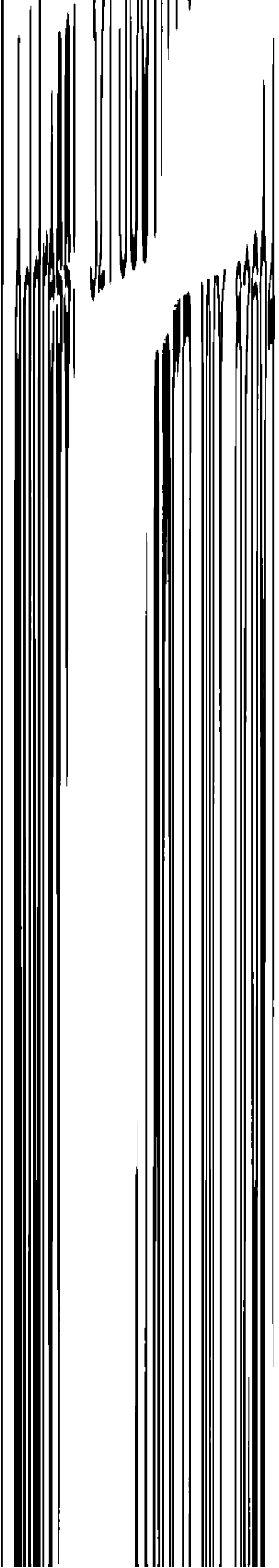
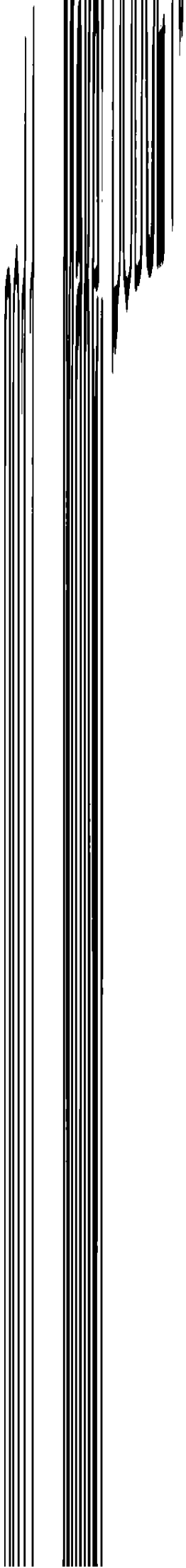

Attn: Case #

[REDACTED]

[REDACTED]

INVOICE
BIG O TIRES # 60092
 2727 CY AVENUE
 CASPER, WY 82604
 (307) 234-2446



Visit us on the web at: www.bigotires.com

Invoice No: 050092-119463 Page 1
 Order No: 95626
 Date: 06/04/2014 Time: 05:49 PM
 Started by: TERRY KANE
 Invoiced by: TERRY KANE

Vehicle Information Year: 2011 Make: DODGE-RAM TRUCK
 Model: RAM 3500 1 TON PICKUP Color:
 License: Odometer: 35,407
 Engine: 6-408 6.7L Dsl VIN:
 Unit: Driver:
 Tire Pressure Front: 0 Rear: 0 Torque: 145
Customer Instructions Save Old Parts? No

Cust.:
 Address:
 City, State, Zip: CASPER, WY
 Home: Work: Cell:
 Bill To:

Part No	Description	QTY	UNIT PRICE	TOTAL PRICE
COM NOTES	FRONT END INSPECTION	1.00	0.00	0.00
A 107200173	245/70R17 FIRESTONE TRANSFORCE A/T	1.00	200.00	200.00
Tire Serial #: TBD				
LAB TICB	COMPUTER WHEEL BALANCE	1.00	0.00	0.00
custom wheels and duallys must be re-torqued in 15 miles after installation and after every tire rotation. Big o tires Casper will not be responsible after 15 miles of wheels being put on or rotated if they are not properly torqued.				
	* THIS IS NOT A BIG O BRAND TIRE	0.00	0.00	0.00
	* THIS TIRE IS COVERED ONLY BY	0.00	0.00	0.00
	* MANUFACTURER'S WARRANTY	0.00	0.00	0.00
	* AGAINST MATERIALS DEFECTS	0.00	0.00	0.00
	* BIG O ROAD HAZARD WARRANTY	0.00	0.00	0.00
	* DOES NOT APPLY	0.00	0.00	0.00
FEE FEETD	TIRE DISPOSAL FEE	1.00	4.00	4.00
LAB ALCF	FREE ALIGNMENT CHECK	1.00	0.00	0.00
RHW TPP	TIRE PROTECTION PLAN	1.00	31.50	31.50
THESE TIRES HAVE ROAD HAZARD COVERAGE***FREE REPLACEMENT FOR THE FIRST THREE YEARS, THEREAFTER FOR THREE ADDITIONAL YEARS OR 3/32" OF TREAD WHICHEVER COMES FIRST A PRORATED WORKMANSHIP AND MATERIALS WARRANTY***FREE ROTATIONS***FREE FLAT REPAIRS***FREE RE-BALANCING***FREE ROADSIDE ASSISTANCE FOR THE USEABLE LIFE OF TIRE / 3 YEARS OR 3/32" OF TREAD. FOR ROADSIDE ASSISTANCE, PLEASE CALL 1-888-592-5068				
N 288-3740	OUTER TIE ROD	3190	1.00	101.79
LAB FEL	FRONT END LABOR	3190	0.40	88.99
LAB AL3	LIGHT TRUCK & VAN ALIGNMENT	3533	1.00	79.99
DIS DISS	SERVICE DISCOUNT	1.00	-30.00	-30.00
COM NOTES	LEFT FRONT OUTER TIE ROD WAS SHEARED OFF	1.00	0.00	0.00
COM NOTES	UPON ARRIVAL. PUNCTURED LEFT FRONT TIRE	1.00	0.00	0.00
*** Technicians who Performed Services on Invoice ***				
[]	[3190] JOSEPH TOMLINSON			
[3533] ROBBIE BUELL				
*** ----- ***				

Invoice Summary

BIG O TIRES WILL NOT BE RESPONSIBLE FOR DAMAGE TO NON STEEL WHEELS AND DUALY WHEELS THAT ARE NOT RE-TORQUED AT 15 MILES AND 100 MILES. ALL ABOVE PURCHASED WARRANTIES REPLACE ALL OTHER WARRANTIES EXPRESSED OR IMPLIED. THANK YOU FOR YOUR BUSINESS.	Payment		Invoice Totals	
	Type	Amount		
	VS	\$468.98	Parts	301.79
			FET	0.00
			Core Chg	0.00
			Labor	118.29
			Waste Disposal	4.00
			Shop Supplies	23.32
			Sales Tax	23.58
			Total:	468.98

I have received the above goods and/or services. If this is a credit card purchase, I agree to pay and comply with the cardholders agreement with the issuer. There are no cancellations allowed.

Customer
 Signature _____

INVOICE
 RES # 80092
 AVENUE
 WY 82804
 234-2446



Visit us on the web at: www.bigotires.com

Invoice No: [REDACTED] Page 2
 Order No: 95926
 Date: 06/04/2014 Time: 05:49 PM
 Started by: TERRY KANE
 Invoiced by: TERRY KANE

Vehicle Information Year: 2011 Make: DODGE-RAM TRUCK
 Model: RAM 3500 1 TON PICKUP Color:
 Mileage: [REDACTED] Odometer: 36,407
 Phone: 6-408-6-7L DSI VIN:
 License: [REDACTED] Driver:
 Tire Pressure Front: 0 Rear: 0 Torque: 145
 Customer Instructions Save Old Parts? No

Cust.: [REDACTED]
 Address: [REDACTED]
 City, State, Zip: CASPER, WY [REDACTED]
 Home: [REDACTED] Work: [REDACTED] Cell:
 Bill To:

Part No.	Description	Quantity	Unit Price	Total Price
----------	-------------	----------	------------	-------------

Invoice Summary

BIG O TIRES WILL NOT BE RESPONSIBLE FOR DAMAGE TO NON STEEL WHEELS AND DUALY WHEELS THAT ARE NOT RE-TORQUED AT 15 MILES AND 100 MILES. ALL ABOVE PURCHASED WARRANTIES REPLACE ALL OTHER WARRANTIES EXPRESSED OR IMPLIED. THANK YOU FOR YOUR BUSINESS.	Payment		Invoice Totals	
	Type	Amount		
	VS	\$468.98	Parts	301.79
			FET	0.00
			Core Chg	0.00
			Labor	116.29
			Waaste Disposal	4.00
			Shop Supplies	23.32
			Sales Tax	23.58
			Total:	468.98

I have received the above goods and/or services. If this is a credit card purchase, I agree to pay and comply with the cardholders agreement with the issuer. There are no cancellations allowed.

Customer Signature _____

(Version: bolasin9 - 20130918)



24 HR. SERVICE

M.A.D.

TRANSPORTATION & TOWING LLC
 2305 SALT CREEK HIGHWAY
 CASPER, WY 82601



HOT SHOT TOWING
 GEN. ILLIUMED
 AUTO HAULING
 ETC...

29442

BUS: (307) 577-8326 • TOLL FREE 888-891-0104 • FAX: (307) 234-5057

TIME OF CALL AM PM	DATE IN 6-4-14	DATE OUT	TIME START AM PM	TIME FINISH AM PM	STOCK No.
--------------------------	-------------------	----------	------------------------	-------------------------	-----------

NAME [REDACTED] PO No.

ADDRESS [REDACTED] RO No.

CITY Casper STATE WY ZIP 82604

YEAR 11 MAKE/MODEL Dodge 2500 COLOR SRK ODOMETER

LIC. PLATE # [REDACTED] STATE WY VIN# 307343HL0BGA [REDACTED]

LOCATION OF VEHICLE Above address

TOWED TO: Big O Tires

REASON FOR TOW <input type="checkbox"/> ACCIDENT <input type="checkbox"/> ABANDONED <input type="checkbox"/> NO START <input type="checkbox"/> FLAT TIRE <input type="checkbox"/> LOCK OUT <input type="checkbox"/> TOW ZONE <input type="checkbox"/> STOLEN <input type="checkbox"/> SNOW REMOVAL <input checked="" type="checkbox"/> BREAKDOWN <input type="checkbox"/> UNREGISTERED	<input type="checkbox"/> OUT OF GAS <input type="checkbox"/> FIRE LANE <input type="checkbox"/> NO TRESPASS <input type="checkbox"/> ARREST <input type="checkbox"/> IMPOUNDED	PERSONNEL'S TAKEN BY PHONE
	TYPE OF TOW <input type="checkbox"/> SLINGSHOT <input checked="" type="checkbox"/> FLAT BEDRAMP <input type="checkbox"/> WHEEL LIFT	VEHICLE STORAGE TIME FROM _____ TO _____ DAYS @ \$ _____

SPECIAL EQUIPMENT <input checked="" type="checkbox"/> WINCH <input type="checkbox"/> FLARES <input type="checkbox"/> DOLLIES <input type="checkbox"/> RAMPS <input type="checkbox"/> SCOTCH BLOCKS <input type="checkbox"/> SNATCH BLOCKS <input type="checkbox"/> ...	TOW ORDERED BY <input type="checkbox"/> STATE POLICE <input type="checkbox"/> LOCAL POLICE <input checked="" type="checkbox"/> OWNER OF CAR <input type="checkbox"/> DEALER	INDICATE DAMAGED AREA 	KEYS LEFT Y N RADIO Y N
	LABOR TIME FINISH _____ START _____	HOOK-UP 90 MILEAGE LABOR	EMPTY MILEAGE FINISH _____ START _____

METHOD OF PAYMENT <input type="checkbox"/> CASH <input checked="" type="checkbox"/> CHECK DRIVERS LIC. # <input type="checkbox"/> MC <input type="checkbox"/> VISA <input type="checkbox"/> OTHER EXP. DATE CREDIT CARD # [REDACTED]	LOADED MILEAGE FINISH _____ START _____ TOTAL	SUB-TOTAL 90 TAX TOTAL 90
---	--	---------------------------------

AUTHORIZED SIGNATURE [REDACTED] DATE [REDACTED] OTHER SERVICES
 SWEEP FIRST AID
 REMOVE AXLE SECURE LOOSE PARTS

NOTE: We cannot be responsible for damages caused by faulty tires, bumper brackets, etc. Not responsible for loss or damage to vehicle due to fire, theft or any other cause beyond our control. Anything left after ninety (90) days will be disposed of at M.A.D.'s discretion.

BIG O TIRE
2727 CY AVE
CASPER WY 82604

DATE: 06/04/14
MERCHANT ID:

TIME: 17:50
JA56053159001

CREDIT CARD
SALE

CARD# *****
EXPIRATION DATE 06/2024
SEQ: 230372
APPROVAL CODE:
ENTRY METHOD: SWIPED

PRODUCT	QTY	PRICE	AMOUNT
GEN AUTO MERCH			468.98
TOTAL AMOUNT:			\$468.98

APPROVED 230372

THANKS FOR YOUR BUSINESS

CUSTOMER COPY

Edge/Ram Truck, SUV & Rear Wheel Drive Van : 1500/2500/3500 Pickup 4X4 (1994-) : 3500 : 2010-13 : except Box Off, Chassis Cab

1-55151 36487

Before Measurements

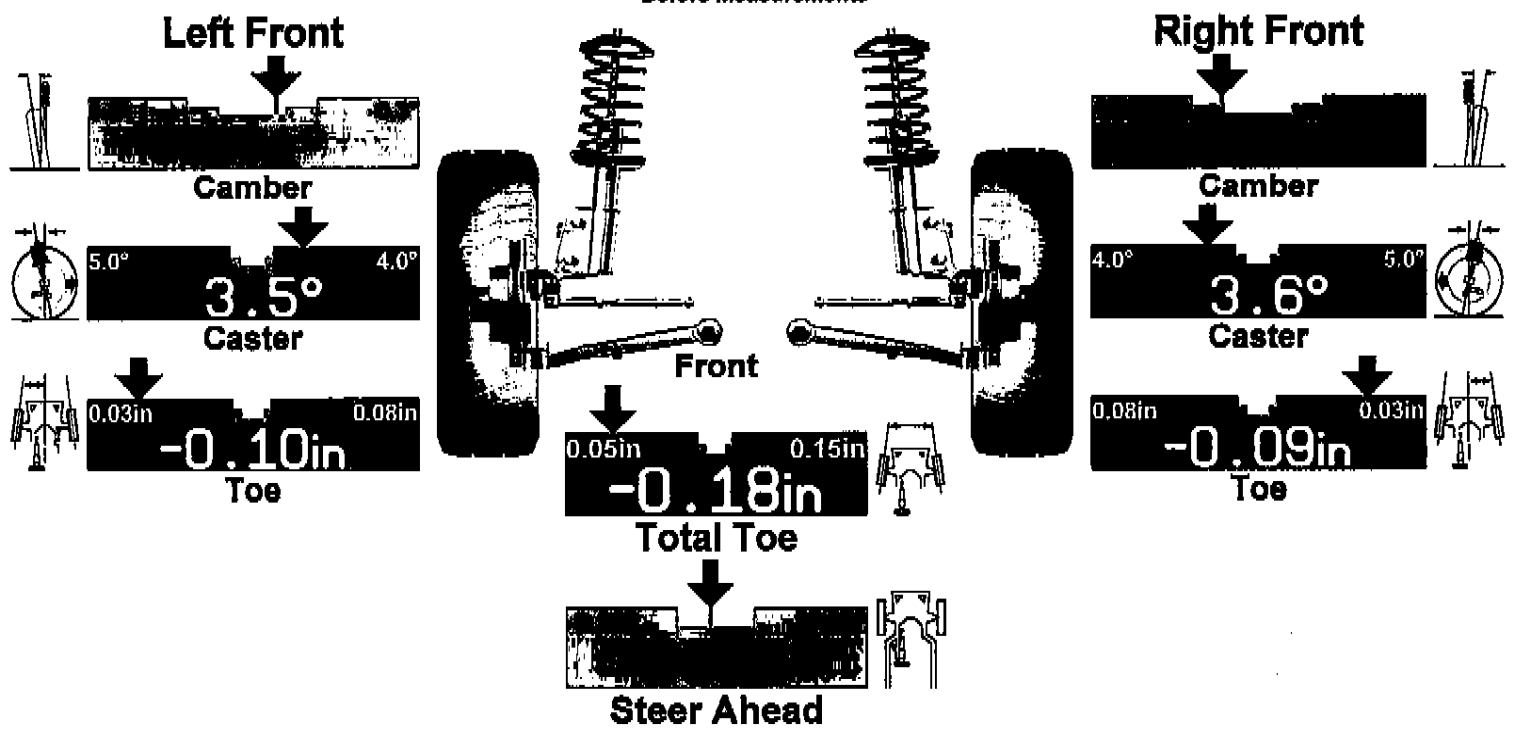

Current Measurements

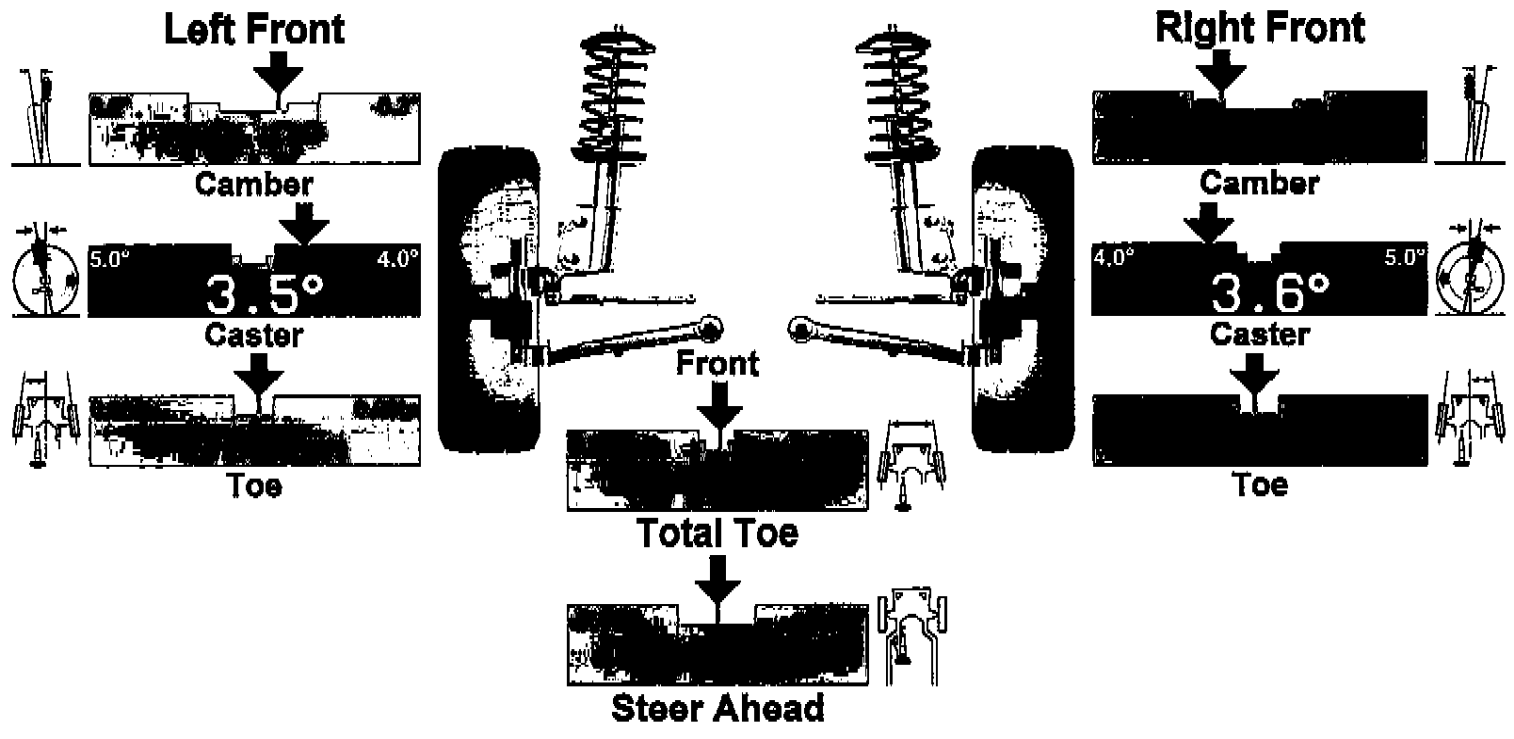

Attn: Case # [REDACTED]

[REDACTED]

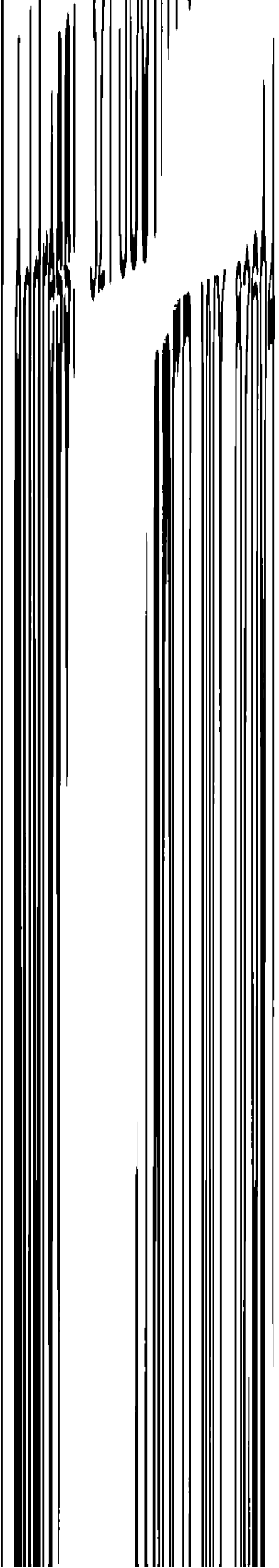
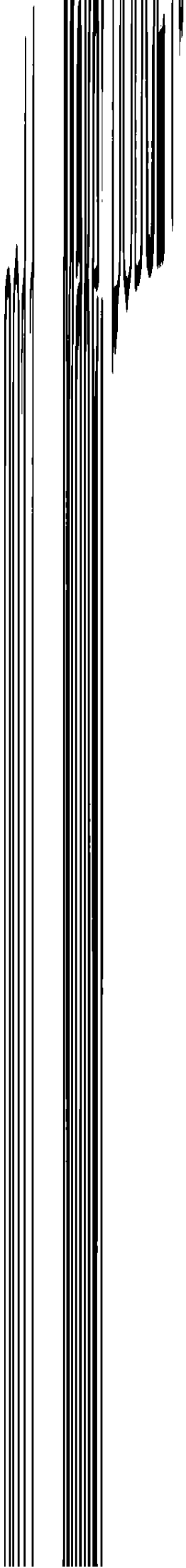

Attn: Case #



INVOICE
BIG O TIRES # 60092
 2727 CY AVENUE
 CASPER, WY 82804
 (307) 234-2446



Visit us on the web at: www.bigotires.com

Invoice No: 050092-119463 Page 1
 Order No: 95526
 Date: 06/04/2014 Time: 05:49 PM
 Started by: TERRY KANE
 Invoiced by: TERRY KANE

Vehicle Information Year: 2011 Make: DODGE-RAM TRUCK
 Model: RAM 3500 1 TON PICKUP Color:
 License: Odometer: 36,407
 Engine: 6-408 8.7L Dsl VIN:
 Unit: Driver:
 Tire Pressure Front: 0 Rear: 0 Torque: 145
Customer Instructions Save Old Parts? No

Cust: [REDACTED]
 Address: [REDACTED]
 City, State, Zip: CASPER, WY
 Home: [REDACTED] Work: [REDACTED] Cell:
 Bill To:

Part No	Description	QTY	UNIT PRICE	AMOUNT	TAX	TOTAL
COM NOTES	FRONT END INSPECTION	1.00	0.00	0.00		
A 107200173	245/70R17 FIRESTONE TRANSFORCE AT	1.00	200.00	200.00		
Tire Serial #: TBD						
LAB TICB	COMPUTER WHEEL BALANCE	1.00	0.00	0.00		
custom wheels and duallys must be re-torqued in 15 miles after installation and after every tire rotation. Big o tires Casper will not be responsible after 15 miles of wheels being put on or rotated if they are not properly torqued.						
	* THIS IS NOT A BIG O BRAND TIRE	0.00	0.00	0.00		
	* THIS TIRE IS COVERED ONLY BY	0.00	0.00	0.00		
	* MANUFACTURER'S WARRANTY	0.00	0.00	0.00		
	* AGAINST MATERIALS DEFECTS	0.00	0.00	0.00		
	* BIG O ROAD HAZARD WARRANTY	0.00	0.00	0.00		
	* DOES NOT APPLY	0.00	0.00	0.00		
FEE FEETD	TIRE DISPOSAL FEE	1.00	4.00	4.00		
LAB ALCF	FREE ALIGNMENT CHECK	1.00	0.00	0.00		
RHW TPP	TIRE PROTECTION PLAN	1.00	31.50	31.50		
THESE TIRES HAVE ROAD HAZARD COVERAGE***FREE REPLACEMENT FOR THE FIRST THREE YEARS, THEREAFTER FOR THREE ADDITIONAL YEARS OR 3/32" OF TREAD WHICHEVER COMES FIRST A PRORATED WORKMANSHIP AND MATERIALS WARRANTY***FREE ROTATIONS***FREE FLAT REPAIRS***FREE RE-BALANCING***FREE ROADSIDE ASSISTANCE FOR THE USEABLE LIFE OF TIRE / 3 YEARS OR 3/32" OF TREAD. FOR ROADSIDE ASSISTANCE, PLEASE CALL 1-866-592-5088						
N 269-3740	OUTER TIE ROD	3190	1.00	101.79		101.79
LAB FEL	FRONT END LABOR	3190	0.40	86.99		86.99
LAB AL3	LIGHT TRUCK & VAN ALIGNMENT	3533	1.00	79.99		79.99
DIS DISS	SERVICE DISCOUNT	1.00	-30.00	-30.00		-30.00
COM NOTES	LEFT FRONT OUTER TIE ROD WAS SHEARED OFF	1.00	0.00	0.00		0.00
COM NOTES	UPON ARRIVAL, PUNCTURED LEFT FRONT TIRE	1.00	0.00	0.00		0.00
*** Technicians who Performed Services on Invoice ***						
[]	[3190] JOSEPH TOMLINSON					
[3533] ROBBIE BUELL						
*** ----- ***						

Invoice Summary

BIG O TIRES WILL NOT BE RESPONSIBLE FOR DAMAGE TO NON STEEL WHEELS AND DUALY WHEELS THAT ARE NOT RE-TORQUED AT 15 MILES AND 100 MILES. ALL ABOVE PURCHASED WARRANTIES REPLACE ALL OTHER WARRANTIES EXPRESSED OR IMPLIED. THANK YOU FOR YOUR BUSINESS.	Payment		Invoice Totals	
	Type	Amount		
	VS	\$468.98	Parts	301.79
			FET	0.00
			Core Chg	0.00
			Labor	116.29
			Waste Disposal	4.00
			Shop Supplies	23.32
			Sales Tax	23.58
			Total:	468.98

I have received the above goods and/or services. If this is a credit card purchase, I agree to pay and comply with the cardholders agreement with the issuer. There are no cancellations allowed.

Customer Signature _____

INVOICE

RES # 80092
 AVENUE
 WY 82604
 234-2448



Visit us on the web at: www.bigotires.com

Invoice No: 050092-119463 Page 2
 Order No: 95926
 Date: 05/04/2014 Time: 05:49 PM
 Started by: TERRY KANE
 Invoiced by: TERRY KANE

Vehicle Information Year: 2011 Make: DODGE-RAM TRUCK
 Model: RAM 3500 1 TON PICKUP Color:
 License: Odometer: 35,407
 Engine: 6-408 6.7L D5I VIN:
 Unit: Driver:
 Tire Pressure Front: 0 Rear: 0 Torque: 145
 Customer Instructions Save Old Parts? No

Cust.:
 Address:
 City, State, Zip: CASPER, WY
 Home: Work: Cell:
 Bill To:

Part No. Description

Invoice Summary

	Payment		Invoice Totals	
	Type	Amount		
BIG O TIRES WILL NOT BE RESPONSIBLE FOR DAMAGE TO NON STEEL WHEELS AND DUALY WHEELS THAT ARE NOT RE-TORQUED AT 15 MILES AND 100 MILES. ALL ABOVE PURCHASED WARRANTIES REPLACE ALL OTHER WARRANTIES EXPRESSED OR IMPLIED. THANK YOU FOR YOUR BUSINESS.	VS	\$468.98	Parts	301.79
			FET	0.00
			Core Chg	0.00
			Labor	116.28
			Waste Disposal	4.00
			Shop Supplies	23.32
			Sales Tax	23.58
			Total:	468.98

I have received the above goods and/or services. If this is a credit card purchase, I agree to pay and comply with the cardholders agreement with the issuer. There are no cancellations allowed.

Customer
 Signature _____



24 HR. SERVICE

M.A.D.

TRANSPORTATION & TOWING LLC
 2305 SALT CREEK HIGHWAY
 CASPER, WY 82601



HOT SHOT TOWING
 GEN. HAULING
 AUTO HAULING
 ETC...

29442

BUS: (307) 577-8328 • TOLL FREE 888-891-0104 • FAX: (307) 234-5057

TIME OF CALL AM PM	DATE IN 6-4-14	DATE OUT	TIME START AM PM	TIME FINISH AM PM	STOCK No.
--------------------------	-------------------	----------	------------------------	-------------------------	-----------

NAME		PO No.	
ADDRESS		RO No.	
CITY Casper	STATE WY	ZIP	
YEAR 11	MAKE/MODEL Dodge 2500	COLOR Blk	ODOMETER
LIC. PLATE #	STATE WY	VIN # 307343HL2BGE	
LOCATION OF VEHICLE Above address			
TOWED TO Big O Tires			

REASON FOR TOW

ACCIDENT
 ABANDONED
 NO START
 FLAT TIRE
 LOCK OUT
 TOW ZONE
 STOLEN
 SNOW REMOVAL
 BREAKDOWN
 UNREGISTERED

OUT OF GAS
 FIRE LANE
 NO TRESPASS
 ARREST
 IMPOUNDED

TYPE OF TOW

SLINGSHOT
 FLAT BEDRAMP
 WHEEL LIFT

TOW ORDERED BY

STATE POLICE
 LOCAL POLICE
 OWNER OF CAR
 DEALER

SPECIAL EQUIPMENT

WINCH
 FLARES
 DOLLIES
 RAMPS
 SCOTCH BLOCKS
 SNATCH BLOCKS

PERSONNEL'S TAKEN BY	PHONE
VEHICLE STORAGE TIME FROM _____ TO _____ DAYS @ \$ _____	
INDICATE DAMAGED AREA	KEYS LEFT
	Y N
	RADIO
	Y N

LABOR TIME	HOOK-UP	90	
	MILEAGE		
EMPTY MILEAGE	LABOR		
	EXTRA PERSON		
FINISH	SPECIAL EQUIP.		
	START		
TOTAL	STORAGE		
	SUB-TOTAL	90	
LOADED MILEAGE	TAX		
	TOTAL	90	

METHOD OF PAYMENT

CASH
 CHECK
 MC
 VISA
 OTHER

DRIVERS LIC. # _____

EXP. DATE _____

CREDIT CARD # _____

AUTHORIZED SIGNATURE _____

DATE _____

DRIVERS SIGN _____

OTHER SERVICES

SWEEP
 REMOVE AXLE
 FIRST AID
 SECURE LOOSE PARTS

NOTE: Not responsible for loss or damage to vehicle due to fire, theft or any other cause beyond our control. Anything left after ninety (90) days will be disposed of at M.A.D.'s discretion.

BIG O TIRE
2727 CY AVE
CASPER WY 82604

DATE: 06/04/14
MERCHANT ID: [REDACTED] TIME: 17:50
JA56053155001

CREDIT CARD
[REDACTED] SALE

CARD# [REDACTED]
EXPIRATION DATE 08/2024
SEQ: 230372
APPROVAL CODE: 230372
ENTRY METHOD: SWIPED

PRODUCT	QTY	PRICE	AMOUNT
GEN AUTO MERCH			468.98
TOTAL AMOUNT:			\$468.98

APPROVED 230372

THANKS FOR YOUR BUSINESS

CUSTOMER COPY

odge/Ram Truck, SUV & Rear Wheel Drive Van : 1500/2500/3500 Pickup 4X4 (1994-) : 3500 :
2010-13 : except Box Off, Chassis Cab

1-55151 36487

Before Measurements

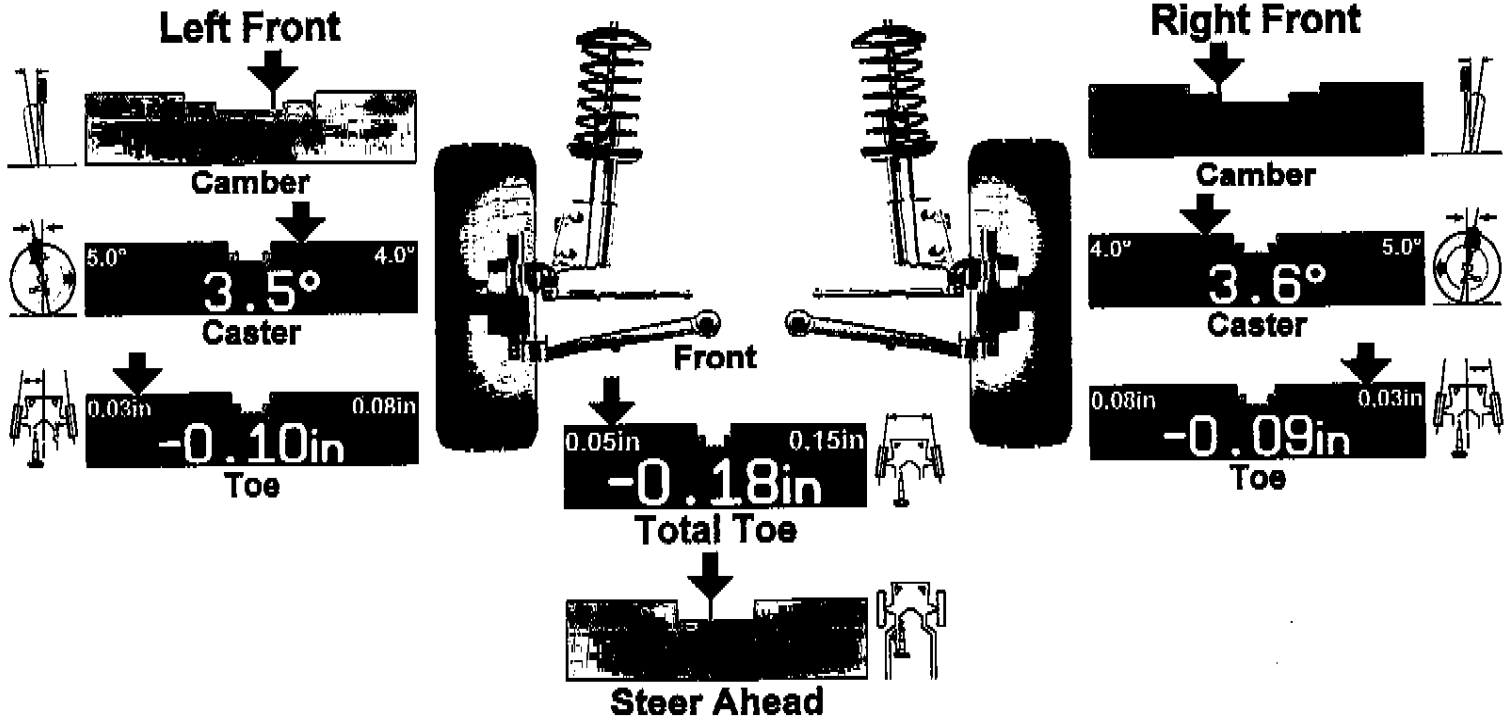

Current Measurements

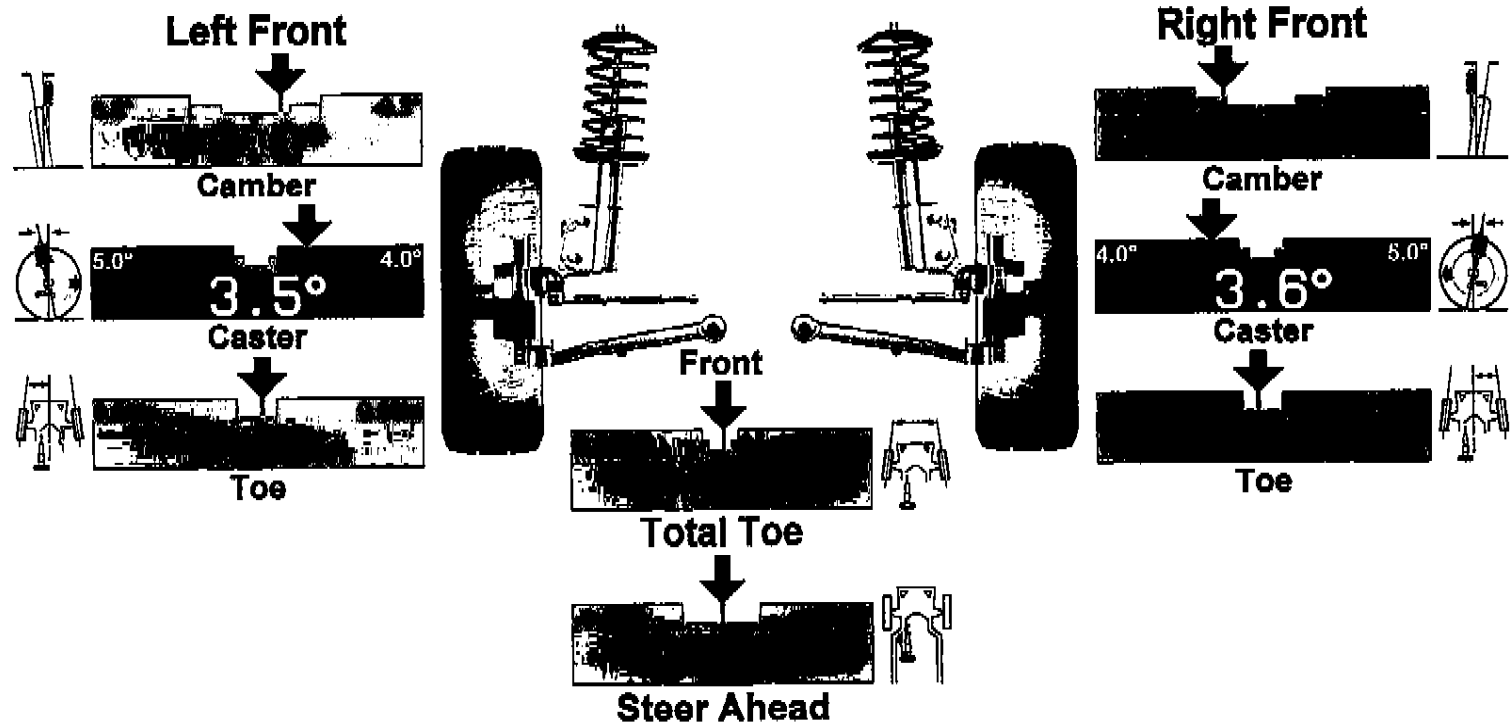

Att'n: Case #





24 HR. SERVICE

M.A.D.

TRANSPORTATION & TOWING LLC
 2905 SALT CREEK HIGHWAY
 CASPER, WY 82601



HOT SHOT TOWING
 GEN. FLAIVED
 AUTO HAULING
 ETC...

29442

BUS: (307) 577-8326 • TOLL FREE 888-891-0104 • FAX: (307) 234-6067

TIME OF CALL AM PM	DATE IN 6-4-14	DATE OUT	TIME START AM PM	TIME FINISH AM PM	STOCK No.
--------------------------	-------------------	----------	------------------------	-------------------------	-----------

NAME	PO No.
ADDRESS	RO No.

CITY Casper	STATE WY	ZIP
----------------	-------------	-----

YEAR 11	MAKE/MODEL Ford 2500	COLOR Blue	ODOMETER
------------	-------------------------	---------------	----------

LIC. PLATE #	STATE WY	VIN # 307343HL23G
--------------	-------------	-------------------

LOCATION OF VEHICLE
Above address

TOWED TO
B.G. O'Neil

- REASON FOR TOW**
- ACCIDENT
 - ABANDONED
 - NO START
 - FLAT TIRE
 - LOCK OUT
 - TOW ZONE
 - STOLEN
 - SNOW REMOVAL
 - BREAKDOWN
 - UNREGISTERED

- OUT OF GAS
- FIRE LANE
- NO TRESPASS
- ARREST
- IMPOUNDED

- TYPE OF TOW**
- SLINGSHOT
 - FLAT BEDRAMP
 - WHEEL LIFT
- TOW ORDERED BY**
- STATE POLICE
 - LOCAL POLICE
 - OWNER OF CAR
 - DEALER

- SPECIAL EQUIPMENT**
- WINCH
 - FLARES
 - DOLLIES
 - RAMPS
 - SCOTCH BLOCKS
 - SNATCH BLOCKS

PERSONNEL'S TAKEN BY	PHONE
----------------------	-------

VEHICLE STORAGE TIME FROM _____ TO _____	DAYS @ \$
---	-----------

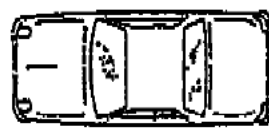
INDICATE DAMAGED AREA 	KEYS LEFT Y N
	RADIO Y N

LABOR TIME	HOOK-UP	90	
	FINISH	MILEAGE	
START	LABOR		

EMPTY MILEAGE	EXTRA PERSON		
FINISH	SPECIAL EQUIP.		
START			
TOTAL	STORAGE		

METHOD OF PAYMENT

CASH CHECK DRIVERS LIC. #

MC VISA OTHER EXP. DATE

CREDIT CARD #

LOADED MILEAGE	SUB-TOTAL	90	
FINISH	TAX		
START	TOTAL	90	
TOTAL			

AUTHORIZED SIGNATURE _____ DATE 6-4-14

DRIVERS S _____

- OTHER SERVICES**
- SWEEP
 - REMOVE AXLE
 - FIRST AID
 - SECURE LOOSE PARTS

NOTE: We cannot be responsible for damages caused by faulty tires, bumper brackets, etc. Not responsible for loss or damage to vehicle due to fire, theft or any other cause beyond our control. Anything left after ninety (90) days will be disposed of at M.A.D.'s discretion.

STORE YOUR DUPLICATE CHECKS IN YOUR CHECK BOX

316

- Track your expenses...
- Clothing
- Credit Card
- Entertainment
- Food
- Utilities
- Insurance
- Transportation
- Mortgage
- Other: _____

UNRECORDED ITEM

MAD
July 10, 2014
93.00
93.00

THIS ITEM	93.00
BALANCE	
DEPOSIT	
OTHER	
BALANCE	
FORWARD	

For added security, your name and account number do not appear on this copy.

NOT NEGOTIABLE

Attn: Case #

[REDACTED]

[REDACTED]

[REDACTED] - current mailing address
[REDACTED] CASPER WY
[REDACTED]



24 HR. SERVICE

M.A.D.
 TRANSPORTATION & TOWING LLC
 2305 SALT CREEK HIGHWAY
 CASPER, WY 82601

29442



HOT SHOT TOWING
 GEN. FLAMED
 AUTO HAULING
 ETC...

BUS: (307) 577-6326 • TOLL FREE 888-891-0104 • FAX: (307) 234-5057

TIME OF CALL AM PM	DATE IN 6-4-14	DATE OUT	TIME START AM PM	TIME FINISH AM PM	STOCK No.
--------------------------	-------------------	----------	------------------------	-------------------------	-----------

NAME: [Redacted] PO No.

ADDRESS: [Redacted] RO No.

CITY: Casper STATE: WY ZIP: [Redacted]

YEAR: 71 MAKE/MODEL: Dodge 2500 COLOR: Blue ODOMETER: [Redacted]

LIC. PLATE # [Redacted] STATE: WY VIN# 307343HL2BG [Redacted]

LOCATION OF VEHICLE: Above address

TOWED TO: Big O Tires

- REASON FOR TOW**
- ACCIDENT
 - ABANDONED
 - NO START
 - FLAT TIRE
 - LOCK OUT
 - TOW ZONE
 - STOLEN
 - SNOW REMOVAL
 - BREAKDOWN
 - UNREGISTERED
- OUT OF GAS
 - FIRE LANE
 - NO TRESPASS
 - ARREST
 - IMPOUNDED

TYPE OF TOW

- SLINGSHOT
- FLAT BEDRAMP
- WHEEL LIFT

TOW ORDERED BY

- STATE POLICE
- LOCAL POLICE
- OWNER OF CAR
- DEALER

- SPECIAL EQUIPMENT**
- WINCH
 - FLARES
 - DOLLIES
 - RAMP
 - SCOTCH BLOCKS
 - SNATCH BLOCKS
 - _____

PERSONNEL'S TAKEN BY _____ **PHONE** _____

VEHICLE STORAGE TIME
 FROM _____ TO _____ DAYS @ \$ _____

INDICATE DAMAGED AREA

KEYS LEFT
 Y N
RADIO
 Y N

LABOR TIME	HOOK-UP	90	
	MILEAGE		
FINISH	LABOR		
	START		

EMPTY MILEAGE	EXTRA PERSON		
FINISH	SPECIAL EQUIP.		
START	STORAGE		
TOTAL			

LOADED MILEAGE	SUB-TOTAL	90	
FINISH	TAX		
START	TOTAL	90	
TOTAL			

METHOD OF PAYMENT

- CASH
- CHECK DRIVERS LIC. # [Redacted]
- MC
- CREDIT

AUTHORIZED SIGNATURE: [Redacted] DATE: 6-4-14

DRIVERS SIGNATURE: [Redacted] DATE: 6-4-14

- OTHER SERVICES**
- SWEEP
 - REMOVE AXLE
 - FIRST AID
 - SECURE LOOSE PARTS

NOTE: We are not responsible for damage caused by faulty tires, bumper brackets, etc. Not responsible for loss or damage to vehicle due to fire, theft or any other cause beyond our control. Anything left after ninety (90) days will be disposed of at M.A.D.'s discretion.

STORE YOUR DUPLICATE CHECKS IN YOUR CHECK BOX.

- Track your expenses...
- Clothing
- Food
- Credit Card
- Utilities
- Entertainment
- Insurance
- Transportation
- Mortgage
- Other

TAX-DEDUCTIBLE ITEM

316

Handwritten: MHD, 10/10/14, 900.00, 7/1/15

BALANCE FORWARDED	
THIS ITEM	900.00
BALANCE	
DEPOSIT	
OTHER	
BALANCE FORWARD	

For added security, your name and account number do not appear on this copy.

NOT NEGOTIABLE

AQ14-003

CHRYSLER

12/12/2014

ENCLOSURE 17

CUSTOMER COMPLAINTS

FINALBACKUP

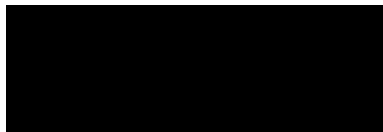

Document Recieved from Customer

Case Number: [REDACTED]

Date Received: 2014-06-16 19:45:51.691378

Files Not Recieved: 0

Attn: [REDACTED]

Case No: [REDACTED]

June 16, 2014

Attn: Teresa

RE: Case Number [REDACTED]

Please see the following receipt for towing in the amount of \$136.42 pertaining to the above referenced Case Number.

Please do not hesitate to contact me with any questions.

Regards,

[REDACTED]
Warsaw, IN [REDACTED]

Cell: [REDACTED]

Email: [REDACTED]



Thompson's Towing
 1407 N Chicago Avenue
 GOSHEN, INDIANA 46528
 (574) 533-2570
 Fax (574) 533-5496

Road Service

DATE	6-9-14	TIME	3:23	A.M. / P.M.	REQUESTED BY	owner	P.O. NO.	15760
NAME	[REDACTED]						PHONE	
ADDRESS	[REDACTED]							
CITY	[REDACTED]							
LOCATION OF VEHICLE	[REDACTED]							
YEAR MAKE MODEL	2008 Dodge Ram 2500							
STATE	IN	VEHICLE I.D. NO.	3D7KS28D39G					REGISTERED OWNER
COLOR	White							DRIVER
MILEAGE		SERVICE TIME		EXTRA PERSON				
FINISH	210551	FINISH	4:20	FINISH 210583				
START	210519	START	3:23	START 210524				
TOTAL	210583	TOTAL	5:50	TOTAL 1.38X59				
REASON FOR TOW			SPECIAL EQUIPMENT					
<input type="checkbox"/> ACCIDENT <input type="checkbox"/> ARREST <input type="checkbox"/> UNREGISTERED <input type="checkbox"/> TOW ZONE <input checked="" type="checkbox"/> SNOW REMOVAL			<input type="checkbox"/> ABANDONED <input type="checkbox"/> STOLEN CAR <input checked="" type="checkbox"/> BREAK DOWN <input type="checkbox"/> LOCK OUT <input type="checkbox"/> START			<input type="checkbox"/> FLAT TIRE <input type="checkbox"/> OUT OF GAS <input type="checkbox"/> IMPOUNDED <input type="checkbox"/> SINGLE LINE WINCHING <input type="checkbox"/> DUAL LINE WINCHING <input type="checkbox"/> SNATCH BLOCKS <input type="checkbox"/> SCOTCH BLOCKS <input type="checkbox"/> DOLLY		
TYPE OF TOW		TOWED PER ORDER OF		VEHICLE TOWED TO				
<input type="checkbox"/> SLING/ HOIST TOW <input checked="" type="checkbox"/> FLAT BED/ RAMP <input type="checkbox"/> WHEEL LIFT <input type="checkbox"/>		<input type="checkbox"/> STATE POLICE <input type="checkbox"/> LOCAL POLICE <input checked="" type="checkbox"/> OWNER <input checked="" type="checkbox"/> DEALER		FIRST TOW [Signature] SECOND TOW				
STORAGE FROM				TOWING CHARGE		55.00		
TO _____ DAYS @ \$ _____				MILEAGE CHARGE		81.42		
PAID BY				EXTRA PERSON				
<input type="checkbox"/> CASH <input type="checkbox"/> CHECK DRIVERS LIC. NO. _____ <input type="checkbox"/> CREDIT CARD <input type="checkbox"/> MC <input type="checkbox"/> VISA <input type="checkbox"/> AMEX EXP. DATE _____				SPECIAL EQUIPMENT				
CC NO. _____				LABOR CHARGE				
OPERATOR'S SIGNATURE [Signature]				STORAGE				
TRUCK NO. [REDACTED]				SUB-TOTAL				
AUTHORIZED SIGNATURE [Signature]				TAX				
VEHICLE RELEASED [REDACTED]				-TOTAL		136.42		

50764

Not responsible for loss or damage to vehicle in case of fire, theft or any other cause beyond our control.

Thank You
 PRODUCT 2525

AQ14-003

CHRYSLER

12/12/2014

ENCLOSURE 17

CUSTOMER COMPLAINTS

FINALBACKUP

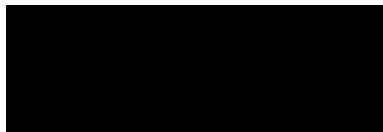

Document Recieved from Customer

Car Number: [REDACTED]

Date Received: 2014-06-11 08:18:12.736944

Files Not Recieved: 0

I was driving on Sunday after church and my driver side tie rod end snapped. All dealer ships were closed so I had tony and sons tow my truck to there shop. I checked with both Roanoke motors and Sam leman Chrysler and neither had parts that they could get until the end of the week. I had to have my truck back for work on Mondays so tony and sons got my truck on the road my noon. I was not aware that my truck had any recalls on the tie rods but i am now in your system. I am a believer in Chrysler products my wife and I have two 2500 dodges with cummins an one project trucks that's a 1996 dodge cummins. I am wanting to get reimburse for the parts and labor from tony and sons. The rim got Scraped up pretty good on the inside but I can live with that it doesn't effect the driving. I am just very thankful that I was not hurt and especially that nobody else was. It was a very weird feeling to not have control. Feel free to give me a call if you need more detail. [REDACTED]



TONY SONS, INC.
 3508 E WASHINGTON
 EAST PEORIA, IL 6161103
 06/09/2014 16:03:18
 Merchant ID: 00000000317174
 Terminal ID: 03441073
 846212531889
 CREDIT CARD
 VISA ADJL
 CARD # [REDACTED]
 INVOICE # [REDACTED]
 Batch #: 0006
 000815
 Approval Code: 631854
 Entry Method: Manual
 Mode: Online
 Tax Amount: \$10.75
 Avs Code: YYY
SALE AMOUNT \$370.03
 CUSTOMER COPY

Tony & Sons Inc.
 3508 E Washington Street
 East Peoria, IL 61611
 (309) 694-3567

Invoice # 17175
 Inv Date: 6/09/2014
 ODD In: 42170 Out: 42173
 License # [REDACTED]
 Color [REDACTED]
 Mileage [REDACTED]
 Unit # [REDACTED]
 Service Writer: Cody Emsit
 Status: Complete
 Driver: [REDACTED]
 PO #: [REDACTED]

2011 RAM 2500 Big Horn/Laramie/Laramie
 License # [REDACTED]
 ODD In: 42170 Out: 42173
 Color [REDACTED]
 Mileage [REDACTED]
 Unit # [REDACTED]

Location: [REDACTED]
 Mobile: [REDACTED]

Vehicle Problems	Requests for Service	Services Performed	Qty	Price	Ext
Customer requests: tow and replace broken tie rod.					
	Labor Service - Towing Charge	000			85.00
Customer requests that: replace LF outer tie rod. It broken.					
	Labor Service - Replace Tie Rod End, Rack & Pinion Type, Outer Tie Rod, One Side, Does Not Include: Adjust Toe-In--tie rod was broken took longer and had to heat with torch	004			79.91
	New Outer Tie Rod End		1.00	112.44	112.44
	Labor Service - Alignment 49-99-99 99--needs front toe adjusted--set front toe to specification	004			59.99
Recommended Repairs and Services:					
	the air filter is dirty and needs replaced				57.49
Notes					
-no oil sticker present, full and very dark -front wipers torn -all lights check good -trans oil full and clean -brake fluid is full and clean -coolant is full and clean -washer fluid is full -hoses check good -battery checks good, terminals are clean and tight -brakes are good looking through wheels					
Warranty					
All repair work is warranted for 12 months/112,000 miles whichever comes first unless stated otherwise on this repair order.					
Invoice Summary					
	Parts				112.44
	Labor				204.91
	Supply Charge				21.90
				Sub Total	359.28
				Sales Tax (IL)	10.75
				Total	370.03

Page 1 of 1
 Original Estimate: 475.03

AQ14-003

CHRYSLER

12/12/2014

ENCLOSURE 17

CUSTOMER COMPLAINTS

FINALBACKUP

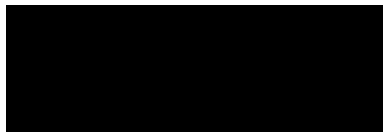

GAWR REAR

4242 KG (9350 LB)

WITH TIRES

LT235/80R17E

17

THIS VEHICLE CONFORMS TO ALL APPLICABLE FEDERAL
PREVENTION STANDARDS IN EFFECT ON THE DATE OF

VIN: 3D7MX48C16G

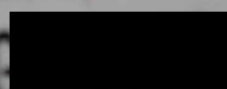

TYPE:

TRU



MDH:

091501

PNT:PS2

VEHICLE MA

MFD BY DAIMLERCHRYSLER
CORPORATION

DATE OF MFR
9-05

GWR
5534 KG(12200 LB)

GAWR FRONT WITH TIRES
2359 KG(5200 LB) LT235/80R17E

RIMS AT
17X6.0

COLD
450 KPA(65 PSI)

GAWR REAR WITH TIRES
4242 KG(9350 LB) LT235/80R17E

RIMS AT
17X6.0

COLD
450 KPA(65 PSI)

THIS VEHICLE CONFORMS TO ALL APPLICABLE FEDERAL MOTOR VEHICLE SAFETY AND THEFT
PREVENTION STANDARDS IN EFFECT ON THE DATE OF MANUFACTURE SHOWN ABOVE.

VIN: 3D7MX48C16G [REDACTED] TYPE: TRUCK SINGLE DUAL X



MDH: 091501 PNT:PS2 VEHICLE MADE IN MEXICO TRM:M9D5 4648507







CHEVY 2500
BIG HORSE

R CROSSINGS















RAM 3500
BIG HORN
EDITION













RF

8F141-1002



















WASHER
FLUID ONLY















































A 1171R























170R
173R
september
113

NOTE POSITION OF PASSENGER
AIRBAG DEPLOYMENT SWITCH
EVIDENCE OF TAMPERING OR
DETERMINED
YES NO NEE
YES, EXPLAIN
ENTIRE UNDERBODY FOR HIDDEN
INCLUDING FRONT AND REAR
COMPONENTS
DAMAGED?









2403048AE

2408052117

2408052117

06 09 05 G

S

74 0304AL
2408 05 2117
2408081117
01 08 09 9
S







24030481333223



MADE IN MEXICO
SIZING 3000000000
PART NO. 1000000000
1000 010000

HOOD







ND
7A01769 AF

ND 00483

ND 00483

ND 00483

02 89 05

P 13



151184

ECU	Code	Status	Description
PCM	P0480	Active	Cooling Fan 1 Control Circuit/Open
PCM	P0243	Active	Turbocharger Wastegate Control Circuit
HMIC	B1044	Active	Panel Mode Door 1 Travel Range Too Small
HMIC	B105D	Stored	Recirculation Door Travel Range Too Large
ORC	B1B06	Active	Driver Airbag Squib 2 Circuit Open
ORC	B1B2E	Active	1st Row Passenger Seat Belt Pretensioner Circuit Open
ORC	B1B2A	Active	1st Row Driver Seat Belt Pretensioner Circuit Open
ORC	B1B0E	Active	Passenger Airbag Squib 2 Circuit Open
ORC	B1B0A	Active	Passenger Airbag Squib 1 Circuit Open
ORC	B1B02	Active	Driver Airbag Squib 1 Circuit Open
ORC	U0019	Stored	CAN B Bus
ORC	U0168	Stored	Lost Communication With Vehicle Security Control Module
RADIO	U0020	Stored	CAN B Bus Off Performance
RADIO	U0019	Stored	CAN B Bus
RADIO	B1421	Active	Audio CD Read Error / Inoperable Disc
TIPMCGW	B1661	Active	Front Left Headlight Control Circuit Open
TIPMCGW	B1634	Active	Left High Beam Control Circuit High
TIPMCGW	B162C	Active	Left Low Beam Control Circuit High
TIPMCGW	U0024	Stored	CAN B Bus (-) Circuit Open
TIPMCGW	B210D	Stored	Battery Voltage Low
TIPMCGW	C1002	Stored	Brake Pedal Switch 1 Circuit High
WCM	B1A06	Active	RKE Fob 1 Performance



Left Front

A close-up photograph of a hand holding a white label with the text "Left Front" next to a tire tread. The tire tread is dark and shows a complex pattern of grooves and sipes. The hand is visible in the lower-left corner, holding the label. The background is dark and out of focus, showing parts of a vehicle's chassis.

Left Front



Left Rear



Left Rear



Right Front

A close-up photograph of a hand holding a white rectangular label with the text "Right Front" in bold black font. The label is positioned next to a heavily worn, dark grey tire tread. The tire shows significant signs of use, with deep grooves and sipes. In the background, parts of a vehicle's suspension system, including a metal control arm and a coil spring, are visible. The overall scene is set in what appears to be a workshop or garage.

Right Front

A close-up photograph of a person's hand holding a white rectangular label with the text "Right Rear" printed in black. The hand is positioned on the left side of the frame, with a metal watch band visible on the wrist. The label is held against a dark grey tire tread, which features a complex, multi-directional siping pattern. The tire is mounted on a metal rim, which is partially visible at the bottom left. The background is dark and out of focus.

Right Rear

A close-up photograph of a hand holding a white rectangular label with the text "Right Rear" printed in black. The label is positioned next to a car tire, which is mounted on a silver alloy wheel. The tire has a prominent tread pattern. The background is a dark, textured surface, likely a garage floor.

Right Rear



















LINCOLN
with 100000

























AQ14-003

CHRYSLER

12/12/2014

ENCLOSURE 17

CUSTOMER COMPLAINTS

FINALBACKUP

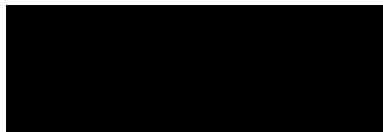



ADVANTAGE EAST ROCHESTER
101 W. COMMERCIAL STREET

EAST ROCHESTER, NY 14445
PHONE: (585) 381-1612

EAGLE AUTO PARTS #145
101 W. COMMERCIAL ST
E. ROCHESTER, NY. 14445

TERMINAL I.D.: 0054078000003543627001
MERCHANT #: 0023543627

SOLD TO: ADVANTAGE AUTO STORE GARAGE 5
101 W. COMMERCIAL STREET

CUST NO: 14500G5
TERMS:

SALESP

E. ROCHESTER NY 14445-2151
585-381-1612

APPLY TO:
REFERENCE: ORDER # [REDACTED]
JOB NO: 000
DEL. DATE: 6/11/14

SALE RECORD # 7
DATE: JUN 11, 14
BATCH: 963
IME: 10:53
AUTH: 7896101

SHIP TO: ADVANTAGE AUTO STORE GARAGE 5
101 W. COMMERCIAL STREET

E. ROCHESTER NY 14445-2151

TOTAL \$78.38
CARD BALANCE: \$6.00

INVC

MFG	PART NUMBER	ORDERED	SHIPPED	SUGG	NET
MM	2011 DODGE-RAM RAM 2500 PICKUP ES800532 OUTER TIE ROD	1	1	72.57	72.57

I AGREE TO PAY ABOVE TOTAL AMOUNT
ACCORDING TO CARD ISSUER AGREEMENT
(MERCHANT AGREEMENT IF CREDIT VOUCHER)
CUSTOMER COPY

** PAID IN FULL **

78.38

TAXABLE 72.57
NON-TAXABLE 0.00
SUBTOTAL 72.57

~~CASE #~~
CASE #



BANKCARD PAYMENT
BKCRD#

78.38

TAX AMOUNT 5.81
TOTAL 78.38

TOT WT: 0.00

X _____
Received By

AQ14-003

CHRYSLER

12/12/2014

ENCLOSURE 17

CUSTOMER COMPLAINTS

FINALBACKUP

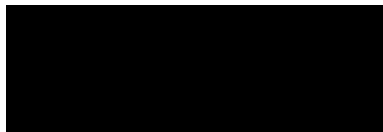

Document Recieved from Customer

Cair Number: [REDACTED]

Date Received: 2014-07-01 11:27:46.865720

Files Not Recieved: 0

I need to be reimbursed for all fees associated with the tire replacement and the front end alignment. Total \$326.92

Carl Gregory Chrysler Jeep
 Dodge Ram of Savannah
 8701 Abercorn St.
 Savannah, GA 31406

35639

MARIANNE

18682

1320

CHCS18010

12,343 /

SAVANNAH, GA

11/DODGE TRUCK/RAM/RAM

01/01/11

3 D 7 U T 2 C L O B G

06/16/14

MO: 12345

LABOR & PARTS

J# 1 40CHZ RECALL HOURS: 1.10 TECH(S):13420 WARRANTY
 RECALL N49. VEHICLE TIE ROD HAS BROKE.
 REPLACED FRONT STEERING PARTS
 LOP 19N49182 1.1

PARTS	QTY	FP-NUMBER	DESCRIPTION	UNIT PRICE	WARRANTY
JOB # 1	1	CBUEN491-AC	PACKAGE 0 19027003		WARRANTY
JOB # 1	1	CBUEN492-AA	NUT NONE 19015005		WARRANTY

JOB # 1 TOTAL PARTS 0.00

JOB # 1 TOTAL LABOR & PARTS 0.00

TOTALS

TOTAL LABOR....	0.00
TOTAL PARTS....	0.00
TOTAL SUBLET...	0.00
TOTAL G.O.G....	0.00
TOTAL MISC CHG.	0.00
TOTAL MISC DISC	0.00
TOTAL TAX.....	0.00

TOTAL INVOICE \$ 0.00

PRE - INVOICE

Steering wheel was off by 20 degrees. No front-end allignment was done by Carl Gregory. I asked when picking up the truck and was told that it was put back in spec.

SAVANNAH TIRE
4318 WATERS AVE SAVANNAH GA 31404
TEL: (912) 352-0004

Store Location
 SAVANNAH TIRE & RUBBER - S04
 4318 WATERS AVE
 SAVANNAH, GA. 31404-6215

Telephone
 (912) 352-0004

Date **Time**
 06/19/14 04:37 PM

file id: S04-68420

Your P/O

A/R Acct
 99-S04

Terms
 1st 10th

Ship Via

Inv: **DA1GSK**

Sold-To:

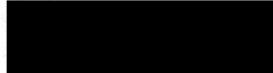

WILMINGTON ISLAND, GA

Ship-To:

Type - Payment	
VISA & M/C\$	326.92
\$	
\$	
=====	
Total \$	326.92

912-658-3152 C
 912-303-9402 CALL C

OCC	D	M	S/T						
Qty	Shp	B/O	Item	Number	Description	S/W	FET	Price	Amount
1			PTO		245/70R17 Michelin LTX M/S2			240.99	240.99
1			STEMR		STEM- RUBBER/TPMS SERVICE PACK			5.99	5.99
1			TDF		STATE TIRE IMPACT FEE			1.00	1.00
1			LTMF		LOCAL TIRE MANAGEMENT FEE			4.00	4.00
1			PMM		MOUNT-INTERNET PRICE MATCH			10.00	10.00
1			BALS		TR-WHEEL BALANCE			7.00	7.00
1			BALSP		WHEEL BALANCE-PARTS			2.99	2.99
1			CPM		CPM-TIRE RACK			-32.99	-32.99
1			ALC		AL-VEHICLE ALIGNMENT CHECK			0.00	0.00
1			AL2		AL-THRUST ANGLE ALIGNMENT			69.99	69.99
			NATIONWIDE SERVICE WARRANTY						
			6 MONTHS OR 6,000 MILES-WHICHEVER COMES FIRST						
4			RHD		CUSTOMER DECLINES ROAD HAZARD			0.00	0.00
					ENV/SHOP FEE				1.60

V/Info: 2011 RAM 2500 WHITE VIN:3D7UT2CL0BG619969
 Lic# BG619969 GA Unt# 6.7L Mil: 712356 Trq: 210 ft#

** Elizabeth @ Chrysler*

\$ 272.92

Case #

Sub-Total
\$310.57

GA 7%, 7.000%
\$16.35

Total: \$326.92
NewPymt: \$326.92
Total Due: **\$0.00**

Received By: _____

SP: JASON WALKER

Print Name.: _____

SAVANNAH TIRE RUBBER
4318 WATERS AVE
SAVANNAH, GA 31404

06/19/2014 16:34:39
Merchant ID: 00000002331712
Terminal ID: 03467518
276191243886

CREDIT CARD

SALE

CARD # .XXXXXXXXXX
INVOICE 0027
Batch #: 000825
Approval Code: 031590
Entry Method: Swiped
Mode: Online

SALE AMOUNT \$326.92

CUSTOMER COPY

AQ14-003

CHRYSLER

12/12/2014

ENCLOSURE 17

CUSTOMER COMPLAINTS

FINALBACKUP

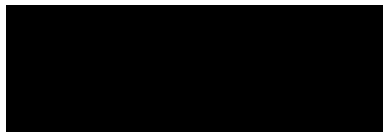

From: [REDACTED]
To: customerassist@chrysler.com
Date: Tue Jun 17 14:37:58 EDT 2014
Subject: Chrysler Group LLC Customer Assistance
Form Selected:

Category: US Customer Service

Brief Description:

ACCIDENT DUE TO TIE ROD BREAKAGE

Comments:

My son was driving this vehicle when the right tie rod broke causing him to veer across traffic and hit the ditch. Thank God no injury but we did require minor repairs and a tow truck. I am aware of tie rod recalls. What liability does RAM assume for tie rod breakage?

Sender Information:

Title:

First Name: [REDACTED]

Middle Initial:

Last Name: [REDACTED]

From: customerassist@chrysler.com

To: [REDACTED]

Date: Thu Jun 19 16:26:20 EDT 2014

Subject: Re: Chrysler Group LLC Customer Assistance

Dear [REDACTED]

Thank you for contacting the RAM Customer Assistance Center.

Our records show that you have contacted us by telephone and we have addressed your concern.

We have updated your file to reflect the latest information you provided in the email message.

If your concerns have not been addressed, or you have other concerns, please email or contact the Chrysler Group Customer Care Center by telephone at 1-866-RAM-INFO (726-4636).

Thank you again for your email. Should you require additional assistance, or have any new information to provide, please reply to this email message or call 1-866-RAM-INFO (1-866-726-4636).

Sincerely,

Heather

Customer Service Representative

RAM Customer Assistance Center

For any future communications related to this email, please refer to the following information:

REFERENCE NUMBER: [REDACTED]

EMAIL CASE NUMBER: [REDACTED]

REPLY LINK:
[REDACTED]

Original Message Follows:

US Customer Service - Ram Brand Site

Brief Description:

ACCIDENT DUE TO TIE ROD BREAKAGE

Comments:

My son was driving this vehicle when the right tie rod broke causing him to veer across traffic and hit the ditch. Thank God no injury but we did require minor repairs and a tow truck. I am aware of tie rod recalls. What liability does RAM assume for tie rod breakage?

VIN:

7G [REDACTED]

Mileage:

80000

Servicing Dealer:

Title:

First Name:

[REDACTED]

Middle Initial:

Last Name:

[REDACTED]

Address 1:

[REDACTED]

Address 2:

City:

AFTON

State:

OK

Zip:

[REDACTED]

Email:

[REDACTED]

Home Phone:

[REDACTED]

AQ14-003

CHRYSLER

12/12/2014

ENCLOSURE 17

CUSTOMER COMPLAINTS

FINALBACKUP

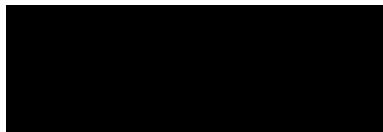

RECEIVED DATE:

06/30/14

POSTED DATE :

6-24-14

VIN (FIRST 9 DIGITS)

3D7KS28D9

VIN (LAST 8 DIGITS)

8G



FIRST NAME:

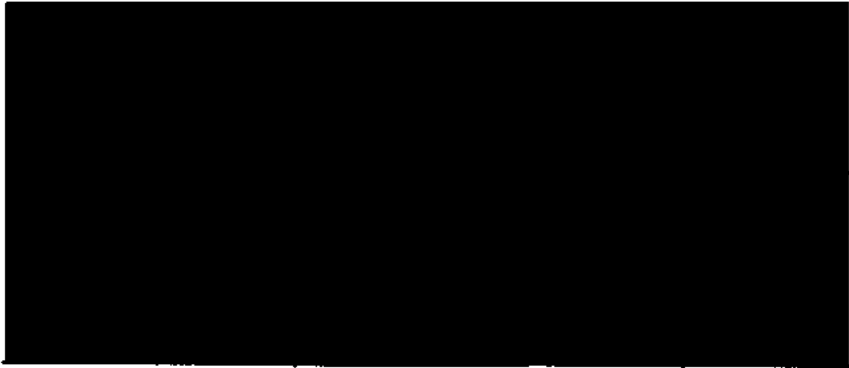

LAST NAME :

CAIR :

000 00000

NON - SCANABLE ITEMS : CIRCLE ONE

NO

YES



IMPORTANT SAFETY RECALL N49 / NHTSA 13V-529

This notice applies to your vehicle (VIN: 3D7KS28D98G [REDACTED]).

This notice is sent to you in accordance with the requirements of the National Traffic and Motor Vehicle Safety Act.

Dear [REDACTED]

Chrysler has decided that a defect, which relates to motor vehicle safety, exists in some **2008 through 2012 model year RAM 1500/2500/3500 series Trucks.**

The problem is... The left tie rod ball stud on your truck may fracture under certain driving conditions. This could cause a loss of directional control and/or crash without warning.

What your dealer will do... Chrysler will repair your vehicle free of charge (parts and labor). To do this, your dealer will replace steering linkage components. The work will take approximately 1 hour to complete. However, additional time may be necessary depending on service schedules.

What you must do to ensure your safety... Simply contact your Chrysler, Jeep, or Dodge dealer starting January 6, 2014 to schedule a service appointment. Ask the dealer to hold the parts for your vehicle or to order them before your appointment. **Please bring this letter with you to your dealer.**

If you need help... If you have questions or concerns which your dealer is unable to resolve, please contact the Chrysler Group Recall Assistance Center at 1-800-853-1403.

Please help us update our records by filling out the attached prepaid postcard if any of the conditions listed on the card apply to you or your vehicle. You may also update this information on the web at www.dodge.com/ownersreg.

If you have already experienced this condition and have paid to have it repaired, please send your original receipts and/or other adequate proof of payment to the following address for reimbursement: Chrysler Customer Assistance, P.O. Box 21-8007, Auburn Hills, MI 48321-8007, Attention: Reimbursement. Once we receive and verify the required documents, reimbursement will be sent to you within 60 days.

If your dealer fails or is unable to remedy this defect without charge and within a reasonable time, you may submit a written complaint to the Administrator, National Highway Traffic Safety Administration, 1200 New Jersey Ave., S.E., Washington, DC 20590, or call the toll-free Vehicle Safety Hotline at 1-888-327-4236 (TTY 1-800-424-9153), or go to <http://www.safercar.gov>.

We're sorry for any inconvenience, but we are sincerely concerned about your safety. Thank you for your attention to this important matter.

Customer Services / Field Operations
Chrysler Group LLC

1/21

Note to lessors receiving this recall: Federal regulation requires that you forward this recall notice to the lessee within 10 days.



CHRYSLER GROUP LLC

CIMS 482-00-85

PO Box 218008

Auburn Hills MI USA 48321-8008

Electronic Service Requested

PRESORTED
FIRST CLASS MAIL
U.S. POSTAGE
P A I D
PERMIT #2655
DETROIT, MI

IMPORTANT!

SAFETY RECALL NOTICE

IMPORTANT SAFETY RECALL INFORMATION

XX #1



Issued in Accordance
With Federal Law



8G2

N49

041681

ERIE, PA



044684/#63093/N49

MILCROTHURST PREPARATORY SCHOOL

538 East Grandview Blvd. • Erie, PA 16504-2697 • 814/824-2210 • FAX: 814/824-2116 • E-mail: mail@mpslakers.com



An International Baccalaureate School

A Recognized School of Excellence

Chrysler Recall Assistance Center
P.O. Box 21-8007
Auburn Hills Mich. 48321-8007

To Whom it May Concern,

I am seeking reimbursement for work done to a recalled tie rod N49/NHTSA 13V-529 for our school's 2008 Dodge Ram. The tie rod ball stud, which was the recalled part, did indeed break as we were awaiting the part to come in to Gary Miller Dodge in Erie, PA. It placed us in an emergency as we needed the truck that weekend of 5/23/14 so we had a local mechanic, Randazzos, tow and fix the truck. On June 12th Gary Miller called to let us know the part was in. They did indicate that it had been taking some time to get the parts. At any rate, I informed them that we already had the part repaired and they indicated that it would be best to put the Chrysler part in, which they did on June 17th. I called on June 19th to see what I had to do to get reimbursed for the part we paid for. I have included the Recall Notice, the bill and proof of payment from Randazzos, as well as a copy of the work done by Gary Miller. I hope this satisfies what we have to do to be reimbursed for the tie rod that broke before the part came in. Please let me know if you need more information.

[REDACTED]
Erie, Pa [REDACTED]
[REDACTED]
[REDACTED]

GARY MILLER

CHRYSLER DODGE JEEP RAM, INC.

5746 Peach Street • ERIE, PA 16509 • (814) 868-3635



CELL - [REDACTED]

CUSTOMER NO 44432	ADVISOR CHRIS FISHER	TAG NO 27128	1693	INVOICE DATE 06/18/14	INVOICE NO CHCS145856
[REDACTED]	LABOR RATE	LICENSE NO	MILEAGE 30,031	COLOR	STOCK NO
ERIE, PA [REDACTED]	YEAR / MAKE / MODEL 08/DODGE TRUCK/RAM 2500/			DELIVERY DATE	DELIVERY MILES
	VEHICLE ID NO. 3 D 7 K S 2 8 D 9 8 G			SELLING DEALER NO	PRODUCTION DATE
	F.T.E. NO	P.O. NO		R.O. DATE 06/17/14	
RESIDENCE PHONE	BUSINESS PHONE	COMMENTS			
		MO: 30034			

LABOR

J# 1 51CHZ **RECALL** TECH(S):37116 **WARRANTY**
 RECALL FOR THE LEFT TIE ROD END SOP HERE
 COMPLETED RECALL N49
 REPLACED STEERING LINKAGE

J# 2 90CHZ **MAINTENANCE CHECKUP** TECH(S):37116 **WARRANTY**
 FREE VEHICLE MAINTENANCE INSPECTION CHECKUP
 COMPLETED

PARTS	QTY	FP NUMBER	DESCRIPTION	UNIT PRICE	WARRANTY
JOB # 1	1	CBUEN491-AB	PACKAGE 0 19027003		
JOB # 1	1	CBUEN492-AA	NUT NONE 19015005		
				TOTAL - LABOR	0.00
				TOTAL - PARTS	0.00

COMMENTS
DROP

TOTALS

INITIALING IS RECEIPT & ACKNOWLEDGEMENT THAT I HAVE RECEIVED
 A COPY OF THE EMISSIONS TEST. INITIALS :

THANK YOU FOR YOUR PATRONAGE BRIAN SHELLEY SERVICE MANAGER

REPAIR WARRANTY
 MOPAR 12MONTHS OR 12,000 MILES WHICHEVER COMES FIRST
 ALL OTHERS 3 MONTHS OR 3,000 MILES WHICHEVER COMES FIRST

CASH () CHK () VISA () M/CARD () AMERX () DISC ()
 REC'D BY

THE UNDERSIGNED HAS READ AND AGREES TO THE TERMS OF THE SALE
 THE UNDERSIGNED HAS RECEIVED ALL COPIES RELATED TO BUT NOT
 LIMITED TO EMISSION TESTING & SAFETY INSPECTIONS

LIMITED WARRANTY:
 This dealership warranties all new parts from the original equipment manufacturer and labor performed in conjunction with this repair for twelve (12) months or twelve thousand (12,000) miles, whichever comes first. If any factory part or labor fails in normal service within that period, the dealership will replace the defective parts and/or repair any defect in workmanship. Any warranty on parts or accessories which are not new original equipment, manufactured parts are made solely by the manufacturer or supplier of said parts. Except for any limited warranty given herein, this dealership disclaims all warranties, express or implied, including any implied warranties of merchantability or fitness for a particular purpose, and neither assumes nor authorizes any other person to assume for it any liability in connection with the sale of said parts and accessories. This dealership shall not be liable for any incidental or consequential damages or commercial losses arising out of such purchase.

CUSTOMER SIGNATURE

TOTAL LABOR 0.00
 TOTAL PARTS 0.00
 TOTAL SUBLET ... 0.00
 TOTAL G.O.G. ... 0.00
 TOTAL MISC CHG. 0.00
 TOTAL MISC DISC 0.00
 TOTAL TAX 0.00
TOTAL INVOICE \$ 0.00

Thank You!

REYNOLDS AND REYNOLDS, ERIE, PA 16509 TEL: 814-868-3635 FAX: 814-868-3636

Form - GV23C To order, please call Bobbaud Farms, at our toll free number 866 422 3576

To: Randazzo's Auto Service

6642
6/20/2014

INVOICE NUMBER	DATE	DESCRIPTION	AMOUNT	DISCOUNT	NET AMOUNT
5/11/14	5/11/2014	08 GMC Van repairs	\$87.95	\$0.00	\$87.95
5/15/14	5/15/2014	2005 GMC Van repairs	\$156.66	\$0.00	\$156.66
5/23/14	5/23/2014	08 Dodge Ram Tire Rod End repair	\$235.76	\$0.00	\$235.76
		Totals:	\$480.37	\$0.00	\$480.37

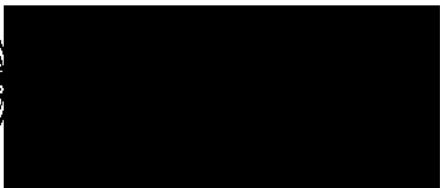

Erie, Pennsylvania
www.mpslakers.com

ERIE PA 165

24 JUN 2014 PM 2 L

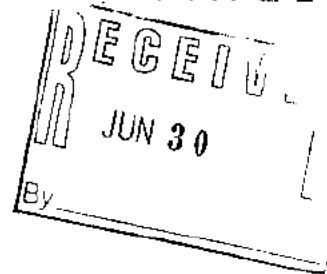
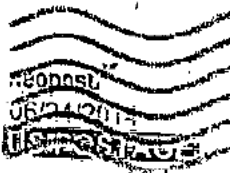

Chrysler Recall Assistance Center
P.O. Box 21-8007
Auburn Hills, Michigan 48321-8007



An International Baccalaureate World School

48321+8007



AQ14-003

CHRYSLER

12/12/2014

ENCLOSURE 17

CUSTOMER COMPLAINTS

FINALBACKUP

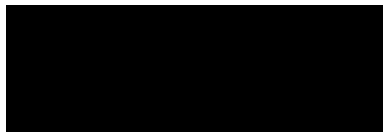

CHRYSLER

July 8, 2014

[REDACTED]
Huguenot, NY [REDACTED]

Reference # [REDACTED]

Dear [REDACTED]

We are delighted to learn of your satisfaction with your 2005 Dodge Ram! Thank you for sharing your experience.

It's quite a milestone to watch your odometer roll over 111,000 miles and to share our appreciation we have enclosed a 100,000 mile license plate bracket for your vehicle. Chrysler Group LLC wants to honor you and your vehicle for this achievement and wish you many more safe and pleasurable driving miles.

Congratulations!

Sincerely,

Susan
Senior Staff

SM/ss

Enclosure

CHRYSLER GROUP LLC

AQ14-003

CHRYSLER

12/12/2014

ENCLOSURE 17

CUSTOMER COMPLAINTS

FINALBACKUP

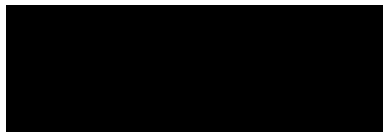

CAIR #:



7/3/14

Jennifer Phillips

From: Mike Driehorst
Sent: Thursday, July 03, 2014 3:33 PM
To: Chrysler Top Care Team Group
Cc: Ed Garsten
Subject: Customer Care: FW: Dodge Ram front end
Attachments: 2006 Dodge Ram (2).pdf

Please see below details from a 2006 Dodge truck owner who said he's had some repairs done on his truck and is seeking reimbursement.

Thank you,
-Mike

Mike Driehorst
 Editorial Director - Online Media
 Chrysler Digital Media
 Chrysler Group LLC
mike.driehorst@Chrysler.com
 Mobile: 248-701-0367
 Twitter: <http://www.Twitter.com/Chrysler>
 Facebook: <https://www.facebook.com/ChryslerGroup>

From: [Redacted]
Sent: Thursday, July 03, 2014 3:29 PM
To: Mike Driehorst
Cc: [Redacted]
Subject: Dodge Ram front end

Hello Mike,

I recently recieved a recall on my left tie rod. Two days after opening the recall notice I was driving while the right side tie rod broke going down the road at around 25 mph. I was pretty lucky I was not traveling on the highway with my 5 year old son on my way to the office. I had it towed to Barret Chrysler in Berlin MD and on monday I was told they couldn't work on a vehicle that long, so I had it towed again to Sherwood of Salisbury MD. The part that was needed to replace what broke had been superseded to another part due to the redesign of the weak front end components. That part even covered what had been recalled on the front end along with many others.

At first I spoke to a parts person at Sherwood and he told me they would take care of the left side parts, labor, and alignment at worst scenerio. I spoke to several people at customer care through Chrysler finally speaking to a supervisor named Nick. He denied everything even that there was a problem with these vehicles. He is on vacation I have been told this week and my case is closed. I am not happy with the way I have been treated by . Sherwood has called and said they want to appeal this case because the customer does not deserve to pay this. I have been told by Sherwood that there are customers that come in there and complain about bills that arent covered and some shouldnt be, but in my case they said Chrysler should be covering this.

I waited one week to get the parts and finally had my truck back on the road a little over a week. As of now Sherwood has one left tie rod and they have a waiting list of 23 trucks that need them. So with that being said there are 23 trucks going up and down these highways that could potentially be thrown off the road resulting in death when it breaks. My final bill from Sherwood was \$642.66 which even included me paying for the side to be replaced that was recalled out of my own pocket. All of these tie rods are weak and have been redesigned from a 2006 to a 2008.5 which is Chryslers fault not me. I am aware of the death wobble and now have experienced it which Chrysler will deny if you speak to them.

I have talked to the GM Matt Romanowski at Sherwood to let him know what has happened, he said he would give Nick a call to see what can be done and understands exactly my problem. Also Courtney Truitt from Sherwood in service has been great and helpful but it was out of her hands. As of now I am giving Chrysler 1 week to resolve this or I am going to my local news and will interview with them and let everyone know about my problems I've recently had with Chrysler. To make this right I need to be reimbursed for my tow to Sherwood from Barrett along with the cost of the faulty design which cost me \$642.66. Keep in mind I never asked for a rental for the week my vehicle was down. If you would like to contact me I can be reached at [REDACTED]

Case # [REDACTED]
Vin # 3D7KS29C06G [REDACTED]
2006 Dodge Ram Mega Cab 5.9 Diesel

Thanks
[REDACTED]

IMPORTANT SAFETY RECALL N62 / NHTSA 13V-528

This notice applies to your vehicle (VIN 3D7KS29C06C [REDACTED])

This notice is sent to you in accordance with the requirements of the National Traffic and Motor Vehicle Safety Act.

Dear [REDACTED]

Chrysler has decided that a defect, which relates to motor vehicle safety, exists in some **2003 through 2008 model year Dodge RAM 1500/2500/3500 series Trucks that had the steering linkage replaced with MOPAR service parts.**

The problem is... The left tie rod ball stud on your truck may fracture under certain driving conditions. This could cause a loss of directional control and/or crash without warning.

What your dealer will do... Chrysler will repair your vehicle free of charge (parts and labor). To do this, your dealer will inspect the steering linkage on your truck and replace steering linkage component(s) if required. The inspection will take less than ½ hour. If linkage replacement is required, the work will take an additional 1 hour to complete. However, additional time may be necessary depending on service schedules.

What you must do to ensure your safety... Simply contact your Chrysler, Jeep, or Dodge dealer starting January 6, 2014 to schedule a service appointment. Ask the dealer to hold the parts for your vehicle or to order them before your appointment. **Please bring this letter with you to your dealer.**

If you need help... If you have questions or concerns which your dealer is unable to resolve, please contact the Chrysler Group Recall Assistance Center at 1-800-853-1403.

Please help us update our records by filling out the attached prepaid postcard if any of the conditions listed on the card apply to you or your vehicle. You may also update this information on the web at www.dodge.com/ownersreg

If you have already experienced this condition and have paid to have it repaired, please send your original receipts and/or other adequate proof of payment to the following address for reimbursement: Chrysler Customer Assistance, P.O. Box 21-8007, Auburn Hills, MI 48321-8007, Attention: Reimbursement. Once we receive and verify the required documents, reimbursement will be sent to you within 60 days.

If your dealer fails or is unable to remedy this defect without charge and within a reasonable time, you may submit a written complaint to the Administrator, National Highway Traffic Safety Administration, 1200 New Jersey Ave., S.E., Washington, DC 20590, or call the toll-free Vehicle Safety Hotline at 1-888-327-4236 (TTY 1-800-424-9153), or go to <http://www.safercar.gov>.

We're sorry for any inconvenience, but we are sincerely concerned about your safety. Thank you for your attention to this important matter.

Customer Services / Field Operations
Chrysler Group LLC

Note to lessees receiving this recall: Federal regulation requires that you forward this recall notice to the lessee within 10 days.

**DODGE****Jeep SRT**

146153

834343

INVOICE



Page 1

1902 North Salisbury Blvd Salisbury, MD 21801
800-510-4650 410-548-4600
Fax: 410-548-4610 www.sherwoodofsalisbury.com

GREEN CITY, MD

HOME [REDACTED] CBUS: N/A

SERVICE ADVISOR: 163 CORTNEY TRUITT

COLOR	YEAR	MAKE/MODEL	VIN	LICENSE	MILEAGE IN / OUT	TAG	
	06	DODGE RAM	3D7KS29C06G [REDACTED]		65799/65799	6909	
DEL. DATE	PROD. DATE	WARR. EXP.	PROMISED	PO NO.	RATE	PAYMENT	INV. DATE
22NOV06 D			17:00 02JUL14			JOTH	02JUL14
R.O. OPENED	READY	OPTIONS: ENG:5.9_Liter_Turbo_Diesel					
7:33 25JUN14	11:31 02JUL14						

LINE	OPCODE	TECH	TYPE	HOURS	LIST	NET	TOTAL
A C/S RIGHT FRONT TIE ROD BROKE WHILE DRIVING MISC REPLACED BROKEN TIE ROD AND DAMPNER 910 FETTERMAN, WILLIAM LIC#: 910 CJ							
1	5154661AC	*	DAMPER-STEERING		119.00	85.44	85.44
1	52122362AL		STEERING-STEERING		350.00	252.00	252.00
3	6505623AA		NUT-HEX LOCK		2.93	2.93	8.79
1	6506276AA		NUT-HEX FLANGE LOCK		4.55	4.55	4.55
PARTS: 350.78 LABOR: 215.88 OTHER: 0.00					TOTAL LINE A:		566.66

...65799 Removed broken tie rod end from knuckle and put bolt through
...knuckle and tie rod to get truck in shop. R&R steering linkage and
...damper.

** 4 WHEEL ALIGNMENT							
4WA 4 WHEEL ALIGNMENT							
7815 AGE, RYAN LIC#: 7815							
CJ							
PARTS: 0.00					LABOR: 89.95	OTHER: 0.00	TOTAL LINE B: 89.95

...65799 Unable to mount heads for alignment

EMAILED RACHAEL 7/2. ABOUT THANK YOU FOR YOUR BUSINESS TODAY!
GETTING 50 % ASSISTANCE

<small> Ford House Bill 1057 AT WHILE THE CUSTOMER'S MOTOR VEHICLE IS ON THE PREMISES OF THE AUTOMOTIVE REPAIR FACILITY, THE AUTOMOTIVE REPAIR FACILITY MAY NOT BE RESPONSIBLE FOR DAMAGE TO THE CUSTOMER'S MOTOR VEHICLE UNDER CERTAIN CIRCUMSTANCES, AND THAT THE CUSTOMER'S SPECIAL AS A REPRESENTATIVE OF THE AUTOMOTIVE REPAIR FACILITY ABOUT THE EXTENT OF RESPONSIBILITY INCLUDED IN THE POINT OF THE INSURANCE COVERAGE OF THE AUTOMOTIVE REPAIR FACILITY. </small>	Manufacturer Special Policy Adjustment programs <small>Federal law requires manufacturers to furnish the National Highway Traffic Safety Administration (N.H.T.S.A.) with bulletins describing any defects in their vehicles. You may obtain copies of these bulletins from either the manufacturer or N.H.T.S.A. In addition, certain consumer publications or organizations publish this information, which may be available for a fee or for free.</small>	STATEMENT OF DISCLAIMER <small>The factory warranty constitutes all of the warranties with respect to the sale of this item/items. The Seller hereby expressly disclaims all warranties either expressed or implied, including any implied warranty of merchantability or fitness for a particular purpose. Seller neither assumes nor authorizes any other person to assume for it any liability in connection with the sale of this item/items.</small>	DESCRIPTION LABOR AMOUNT PARTS AMOUNT SUBLET AMOUNT MISC. CHARGES TOTAL CHARGES DISCOUNTS / COUPON SALES TAX	TOTALS 305.83 350.78 0.00 0.00 656.61 35.00 21.05
	CUSTOMER SIGNATURE _____			INVOICE TOTAL 642.66



Motorsport



KIA MOTORS



CUSTOMER COPY



Document Recieved from Customer

Cair Number: [REDACTED]

Date Received: 2014-06-26 08:02:38.951807

Files Not Recieved: 0

No 11596 TOWING REPORT



**JOHN'S AUTO BODY
REPAIR & TOWING**

9028 Worcester Hwy. • Berlin, MD 21811
Phone (410) 641-3911
FAX # (410) 641-9386

CALL NO.			Date 6-22-14		
CALL TIME			City		
TYPE OF CALL			State		
SERVICE TIME			Home Phone	Insurance Company	Insurance Phone
EXTRA MAN			Business Phone	06 MD	06 Dodge Pickup Gray
MILEAGE FINISH			PK 1136 MD	Mileage	1 2 3 4 5 6 7 8 9 10 11 12 13 14 15 16 17 18 19 20 21 22 23 24 25 26 27 28 29 30 31 32 33 34 35 36 37 38 39 40 41 42 43 44 45 46 47 48 49 50
MILEAGE START		<input type="checkbox"/> START <input type="checkbox"/> BATTERY <input type="checkbox"/> FLAT TIRE <input type="checkbox"/> GAS <input type="checkbox"/> LOCKOUT		<input type="checkbox"/> WRECK <input checked="" type="checkbox"/> TOW <input type="checkbox"/> CARRIER <input type="checkbox"/> FLAT BED <input type="checkbox"/> INSURED	
MILEAGE TOTAL		REMARKS Tax # 4106321830 PAID 6-22-14 Cash		MILEAGE CHARGE TOWING CHARGE # 200.00 ROAD SERVICE CHARGE STORAGE CHARGE SUB TOTAL TAX TOTAL # 200.00	
TOWED FROM		Ocean City, MD Bridge Shell			
TOWED TO		Barrett Chev.			
MECHANIC'S SIGNATURE		AUTHORIZED SIGNATURE			
x Matt		X			

AQ14-003

CHRYSLER

12/12/2014

ENCLOSURE 17

CUSTOMER COMPLAINTS

FINALBACKUP

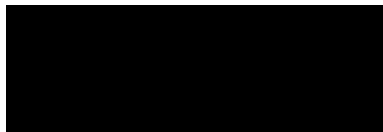

From: [REDACTED]
To: customerassist@chrysler.com
Date: Sun Jun 22 19:50:06 EDT 2014
Subject: Chrysler Group LLC Customer Assistance
Form Selected:

Category: US Customer Service

Brief Description:

N49 recall

Comments:

I have been on a list with Larry H, Miller since January 2014 to get the left front tie rod replaced. LH Miller tells me that I am 212th on the list and they are working on # 57. How important is this recall. I tow a 19K trailer and would not like this tie rod to break. I cannot imagine the loss of control while towing a 42 ft trailer. LHM is telling me that you, Daimler is only sending one tie rod at a time. Come on folks is this another General motors, I don't care. Please send more tie rods so I can get my truck fixed before I leave Utah in the fall. I travel 6 months of the year now that I have retired. Lets get this fixed. [REDACTED] Tooele Utah [REDACTED].Hurry before I wreck.

Sender Information:

Title:

First Name: [REDACTED]

Middle Initial:

Last Name: [REDACTED]

From: customerassist@chrysler.com

To: [REDACTED]

Date: Tue Jun 24 03:01:55 EDT 2014

Subject: Re: Chrysler Group LLC Customer Assistance

Dear [REDACTED]

Thank you for contacting the RAM Customer Assistance Center.

We apologize for the delay with the parts.

Due to the limited availability, the dealership is only able to order 1 part every 2 weeks. We have placed you on the waiting list to receive the recalled part.

The dealership will be in contact with you once the recall part has come in for your vehicle.

Thanks again for your email and we are sorry we are unable to provide you a more favorable reply.

We would like to advise you of an open L38 recall on your vehicle. You may contact you dealer or you can access the self-service recall site on the internet to check on your vehicle's involvement in any/all recalls that are published. Simply go to our brand site Jeep® -

<http://www.Jeep.com/en/owners> and enter your Vehicle Identification Number (VIN) in the appropriate recall field on the left.

Thank you again for your email. Should you require additional assistance, or have any new information to provide, please reply to this email message or call 1-866-RAM-INFO (1-866-726-4636).

Sincerely,

William Reddion

Customer Service Representative

RAM Customer Assistance Center

For any future communications related to this email, please refer to the following information:

REFERENCE NUMBER: [REDACTED]

EMAIL CASE NUMBER: [REDACTED]

REPLY LINK:
[REDACTED]

Original Message Follows:

US Customer Service - Dodge Brand Site

Brief Description:

N49 recall

Comments:

I have been on a list with Larry H, Miller since January 2014 to get the left front tie rod replaced. LH Miller tells me that I am 212th on the list and they are working on # 57. How important is this recall. I tow a 19K trailer and would not like this tie rod to break. I cannot imagine the loss of control while towing a 42 ft trailer. LHM is telling me that you, Daimler is only sending one tie rod at a time. Come on folks is this

another General motors, I don't care. Please send more tie rods so I can get my truck fixed before I leave Utah in the fall. I travel 6 months of the year now that I have retired. Lets get this fixed. [REDACTED] Tooele Utah [REDACTED].Hurry before I wreck.

VIN:

BG [REDACTED]

Mileage:

34000

Servicing Dealer:

Larry H. Miller in Sandy, Utah

Title:

First Name:

[REDACTED]

Middle Initial:

Last Name:

[REDACTED]

Address 1:

[REDACTED]

Address 2:

City:

Tooele

State:

UT

Zip:

[REDACTED]

Email:

[REDACTED]

Home Phone:

[REDACTED]

From: [REDACTED]

To: customerassist@chrysler.com

Date: Tue Jun 24 17:07:00 EDT 2014

Subject: Reply to Chrysler Group LLC ([REDACTED])

Reply Comments:

What is the recourse if the left front tie rod breaks causing a serious accident while I am waiting for the dealer? This part could cause serious if not fatal outcome let alone proper damage in the +100K range. Ed Bartunek

From: customerassist@chrysler.com

To: [REDACTED]

Date: Tue Jun 24 22:18:38 EDT 2014

Subject: Re: Reply to Chrysler Group LLC [REDACTED]

Dear [REDACTED]

Thank you for contacting the RAM Customer Assistance Center.

We have received your email and are sorry for your concerns you are experiencing with your vehicle.

We advise that if you are concerned with the safety of your vehicle that you get the vehicle diagnosed to ensure the safety of your vehicle until your repair date.

We're sorry we cannot provide a more favorable reply. Thank you for your patience.

Thank you again for your email. Should you require additional assistance, or have any new information to provide, please reply to this email message or call 1-866-RAM-INFO (1-866-726-4636).

Sincerely,

William

Customer Service Representative

RAM Customer Assistance Center

For any future communications related to this email, please refer to the following information:

REFERENCE NUMBER: [REDACTED]

EMAIL CASE NUMBER: [REDACTED]

REPLY LINK:
[REDACTED]

Original Message Follows:

Comments:

What is the recourse if the left front tie rod breaks causing a serious accident while I am waiting for the dealer? This part could cause serious if not fatal outcome let alone proper damage in the +100K range. [REDACTED]
[REDACTED]

AQ14-003

CHRYSLER

12/12/2014

ENCLOSURE 17

CUSTOMER COMPLAINTS

FINALBACKUP

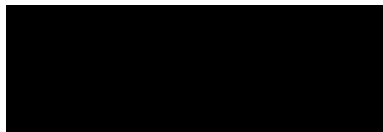

From: [REDACTED]
To: customerassist@chrysler.com
Date: Sun Jun 22 20:39:12 EDT 2014
Subject: Chrysler Group LLC Customer Assistance
Form Selected:

Category: US Customer Service

Brief Description:

tie rods

Comments:

Hi I took my truck to village moter sales on 6-04-14 for an inspection of my tie rods due to a recall. I also asked them to check the truck out for any problems they saw, my tie rods broke on 6-19-14 after the service. I think they should of seen the problem at the time.

Sender Information:

Title:

First Name: [REDACTED]

Middle Initial:

Last Name: [REDACTED]

From: customerassist@chrysler.com

To: [REDACTED]

Date: Tue Jun 24 05:09:15 EDT 2014

Subject: Re: Chrysler Group LLC Customer Assistance

Dear [REDACTED],

Thank you for contacting the Dodge Customer Assistance Center.

I regret the problem your vehicle has experienced and appreciate the time and effort you took to bring this matter to our attention.

If a recalled item becomes defective after it has been replaced then it will be covered by Chrysler like a normal recall. However, your dealership will have to perform a diagnosis to determine if the recalled part has become defective before any recall repair work can be done. As well, if the original part has been replaced after the original installation or any form of negligence has occurred with the part itself, it will not be covered by Chrysler.

Once your vehicle has been diagnosed by a dealer, please advise by responding to this email message using the link below or calling Dodge Customer Assistance at 1-800-423-6343 and we will then direct your concern to the appropriate area to assist you further.

Thank you again for your email. Should you require additional assistance, or have any new information to provide, please reply to this email message or call 1-800-4A-DODGE (1-800-423-6343).

Sincerely,

William

Customer Service Representative

Dodge Customer Assistance Center

For any future communications related to this email, please refer to the following information:

REFERENCE NUMBER: [REDACTED]

EMAIL CASE NUMBER: [REDACTED]

REPLY LINK:
[REDACTED]

Original Message Follows:

US Customer Service - Dodge Brand Site

Brief Description:

tie rods

Comments:

Hi I took my truck to village moter sales on 6-04-14 for an inspection of my tie rods due to a recall. I also asked them to check the truck out for any problems they saw, my tie rods broke on 6-19-14 after the service. I think they should of seen the problem at the time.

VIN:

7J [REDACTED]

Mileage:

100567

Servicing Dealer:

21130

Title:

First Name:

█

Middle Initial:

Last Name:

█

Address 1:

██

Address 2:

City:

ann arbor

State:

MI

Zip:

██████

Email:

██

Home Phone:

████████████████

From: [REDACTED] t

To: customerassist@chrysler.com

Date: Sun Aug 24 10:00:21 EDT 2014

Subject: Reply to Chrysler Group LLC (K [REDACTED])

Reply Comments:

Hi my name is [REDACTED] I am inquiring about my claim that I mailed in
early July ref# [REDACTED] I was wondering what the status of my rebate
thank you [REDACTED]

From: customerassist@chrysler.com

To: k[REDACTED]

Date: Wed Sep 03 04:19:43 EDT 2014

Subject: Re: Reply to Chrysler Group LLC ([REDACTED])

Dear [REDACTED],

We are sorry for the lateness of this reply. your documents have been received and are in the reimbursement process. We have had a large flux of letters as of late and it has been delaying out processes. We will be processing your claim as quick as we can and thank you for your continued patience.

Thank you again for your email. Should you require additional assistance, or have any new information to provide, please reply to this email message or call 1-866-RAM-INFO (1-866-726-4636).

Sincerely,

Robert

Customer Service Representative

RAM Customer Assistance Center

For any future communications related to this email, please refer to the following information:

REFERENCE NUMBER: [REDACTED]

EMAIL CASE NUMBER: [REDACTED]

REPLY LINK:
[REDACTED]

Original Message Follows:

Comments:

Hi my name is [REDACTED] I am inquiring about my claim that I mailed in early July ref#[REDACTED], I was wondering what the status of my rebate thank you [REDACTED]