

PE13-027

CHRYSLER

10-7-2013

ENCLOSURE 4

Legal Claims

MATTER #	██████████
FILE TYPE	Legal Claim
FILE NAME	████████████████████
CAIR #	20281946
DATE OF INCIDENT	██████████
DATE OF NOTICE	1/3/11
MODEL/MODEL YEAR	2011 Jeep Grand Cherokee Leredo
VIN	1J4RR4GG4BC ██████████
MILEAGE	1,705
OWNER	████████████████████
COURT	None
DOCKET #	None
ALLEGED DEFECT DESCRIPTION	Interior Fire The owner stated that he brought his vehicle to the dealer for a repair of inoperative windshield wipers and non-working interior lights. The following day while driving he noticed a burning odor, smoke and flames from the right side of the sun visor. The owner stopped the vehicle and exited without injury and called the fire department.
CRASH	No
PROPERTY DAMAGE	No
INJURIES	0
FATALITIES	0
ANALYSIS	An inspection ¹ of the vehicle revealed that fuse M10 was blown (visor lamp). The cause appeared to be wire arcing to the inner roof panel and burn marks were found adjacent to the visor lamp wiring.

¹ The inspection was conducted at the request of counsel in anticipation of litigation and the report is being withheld under a claim of attorney work-product privilege.

MATTER #	██████████
FILE TYPE	Legal Claim
FILE NAME	██████████
CAIR #	21131293
DATE OF INCIDENT	██████████
DATE OF NOTICE	7/20/11
MODEL/MODEL YEAR	2011 Jeep Grand Cherokee Laredo 4x4
VIN	1J4RR4GT5BC ██████████
MILEAGE	9,900
OWNER	██████████
COURT	None
DOCKET #	None
ALLEGED DEFECT DESCRIPTION	Interior Fire The owner stated that after starting her car and letting it sit idle for 3 minutes with the A/C on she saw smoke coming from the right sun visor mount. She opened the sunroof and the left front window. The owner then proceeded to drive when she saw flames coming from the right sun visor mount. The owner stopped the vehicle and exited without injury and called the fire department.
CRASH	No
PROPERTY DAMAGE	No
INJURIES	0
FATALITIES	0
ANALYSIS	An inspection ² of the vehicle revealed that the origin of the fire was the sun visor mount/pivot. The cause appeared to be an electrical short at the right sun visor mount.

² The inspection was conducted at the request of counsel in anticipation of litigation and the report is being withheld under a claim of attorney work-product privilege.

MATTER #	██████████
FILE TYPE	Legal Claim
FILE NAME	████████████████████
CAIR #	21686117
DATE OF INCIDENT	██████████
DATE OF NOTICE	12/21/11
MODEL/MODEL YEAR	2011 Jeep Grand Cherokee Laredo 4x4
VIN	1J4RR4GG2BC ██████████
MILEAGE	8,000
OWNER	████████████████████
COURT	None
DOCKET #	None
ALLEGED DEFECT DESCRIPTION	Interior Fire The owner stated that she had been driving her vehicle for approximately 40 miles when she parked her car and went inside her mother's home. Approximately 15 minutes later she was notified that her car was on fire at which time she observed fire in the overhead console and called the fire department. No injuries were sustained as a result of the incident.
CRASH	No
PROPERTY DAMAGE	No
INJURIES	0
FATALITIES	0
ANALYSIS	An inspection ³ of the vehicle revealed that the origin of the fire was the overhead console center due to shorted wires of the sunroof, vanity light and interior dome lights.

³ The inspection was conducted at the request of counsel in anticipation of litigation and the report is being withheld under a claim of attorney work-product privilege.

MATTER #	██████████
FILE TYPE	Legal Claim
FILE NAME	████████████████████
CAIR #	21747059
DATE OF INCIDENT	██████████
DATE OF NOTICE	1/9/12
MODEL/MODEL YEAR	2012 Jeep Grand Cherokee Overland 4x4
VIN	1C4RJFCG2C0 ██████████
MILEAGE	2,366
OWNER	████████████████████
COURT	None
DOCKET #	None
ALLEGED DEFECT	Interior Fire
DESCRIPTION	The owner states that he and his wife were driving when they noticed a burning rubber odor at which time they rolled down the windows and the odor cleared. Upon stopping at a stop light they noticed smoke and flames above the driver's sun visor. The owner and his wife exited the vehicle without injury and called the fire department.
CRASH	No
PROPERTY DAMAGE	No
INJURIES	0
FATALITIES	0
ANALYSIS	An inspection ⁴ of the vehicle revealed that the origin of the fire was the driver grab handle bracket front screw. The cause appeared to be an electrical short.

⁴ The inspection was conducted at the request of counsel in anticipation of litigation and the report is being withheld under a claim of attorney work-product privilege.

MATTER #	██████████
FILE TYPE	Legal Claim
FILE NAME	████████████████████
CAIR #	21850450
DATE OF INCIDENT	██████████
DATE OF NOTICE	2/6/12
MODEL/MODEL YEAR	2012 Dodge Durango Crew Awd
VIN	1C4RDJDG8CC ██████████
MILEAGE	100
OWNER	████████████████████
COURT	None
DOCKET #	None
ALLEGED DEFECT DESCRIPTION	Interior Fire The owner stated that when she approached her parked vehicle she noticed there were flames starting at the rear view mirror and going to the back of the vehicle. She called the fire department to extinguish the fire. No injuries were sustained as a result of the incident.
CRASH	No
PROPERTY DAMAGE	No
INJURIES	0
FATALITIES	0
ANALYSIS	An inspection ⁵ of the vehicle revealed that the fire originated in the interior headliner, right front corner of the passenger side. The root cause of the fire was unknown.

⁵ The inspection was conducted at the request of counsel in anticipation of litigation and the report is being withheld under a claim of attorney work-product privilege.

MATTER #	██████████
FILE TYPE	Legal Claim
FILE NAME	████████████████████
CAIR #	22011713
DATE OF INCIDENT	██████████
DATE OF NOTICE	3/19/12
MODEL/MODEL YEAR	2012 Jeep Grand Cherokee Laredo 4x4
VIN	1C4RJFAG9CO ██████████
MILEAGE	1,280
OWNER	████████████████████
COURT	None
DOCKET #	None
ALLEGED DEFECT	Interior Fire
DESCRIPTION	The owner stated that she had returned from driving approximately 35 miles when she noticed smoke and smelled burning from within the vehicle. The smoke appeared to come from the sun visor and sunroof area. The owner ran into her house and got a fire extinguisher to put the fire out. No injuries were sustained as a result of the incident.
CRASH	No
PROPERTY	No
DAMAGE	
INJURIES	0
FATALITIES	0
ANALYSIS	An inspection ⁶ of the vehicle revealed that the fire originated in the right side sun visor area. The cause appears to be a shorted wire. The right sun visor vanity mirror wire was pinched between the mirror mount and roof panel.

⁶ The inspection was conducted at the request of counsel in anticipation of litigation and the report is being withheld under a claim of attorney work-product privilege.

MATTER #	██████████
FILE TYPE	Legal Claim
FILE NAME	████████████████████
CAIR #	22027135
DATE OF INCIDENT	██████████
DATE OF NOTICE	3/21/12
MODEL/MODEL YEAR	2011 Jeep Grand Cherokee Limited 4x4
VIN	1J4RR5GT1BO ██████████
MILEAGE	7,363
OWNER	████████████████████
COURT	None
DOCKET #	None
ALLEGED DEFECT	Interior Fire
DESCRIPTION	The owner stated that while driving her vehicle the passenger side mirror and headliner caught on fire. The fire was extinguished and no injuries were sustained as a result of the incident.
CRASH	No
PROPERTY DAMAGE	No
INJURIES	0
FATALITIES	0
ANALYSIS	An inspection ⁷ of the vehicle revealed that the fire originated in the right side sun visor area. The cause appeared to be a shorted wire. The right sun visor vanity mirror wire was pinched between the mirror mount and roof panel.

⁷ The inspection was conducted at the request of counsel in anticipation of litigation and the report is being withheld under a claim of attorney work-product privilege.

MATTER #	[REDACTED]
FILE TYPE	Legal Claim
FILE NAME	[REDACTED]
CAIR #	22046945
DATE OF INCIDENT	[REDACTED]
DATE OF NOTICE	3/27/12
MODEL/MODEL YEAR	2012 Jeep Grand Cherokee Overland 4x4
VIN	1C4RJFCT8CC [REDACTED]
MILEAGE	1,618
OWNER	[REDACTED]
COURT	None
DOCKET #	None
ALLEGED DEFECT DESCRIPTION	Interior Fire The owner claims that his passenger overhead vanity lamp caused an electrical fire in his vehicle. There is no additional information known at this time.
CRASH	No
PROPERTY DAMAGE	No
INJURIES	0
FATALITIES	0
ANALYSIS	An inspection ⁸ of the vehicle revealed that the fire originated in the right side sun visor vanity mirror lamps. The cause appeared to be electrical.

⁸ The inspection was conducted at the request of counsel in anticipation of litigation and the report is being withheld under a claim of attorney work-product privilege.

MATTER #	██████████
FILE TYPE	Legal Claim
FILE NAME	████████████████████
CAIR #	22384829
DATE OF INCIDENT	██████████
DATE OF NOTICE	7/3/12
MODEL/MODEL YEAR	2011 Dodge Durango Crew Awd
VIN	1D4RE4GG8BC ██████████
MILEAGE	16,011
OWNER	████████████████████
COURT	None
DOCKET #	None
ALLEGED DEFECT DESCRIPTION	Interior Fire The owner stated he was driving his vehicle when he noticed a burning smell and suddenly saw smoke coming from in between the headliner and the windshield near the passenger side sun visor. The owner pulled over and called the fire department. No injuries were sustained as a result of the incident.
CRASH	No
PROPERTY DAMAGE	No
INJURIES	0
FATALITIES	0
ANALYSIS	An inspection ⁹ of the vehicle revealed that the fire originated in the right side sun visor vanity mirror lamps. The cause appeared to be electrical.

⁹ The inspection was conducted at the request of counsel in anticipation of litigation and the report is being withheld under a claim of attorney work-product privilege.

MATTER #	██████████
FILE TYPE	Legal Claim
FILE NAME	██
CAIR #	22428367
DATE OF INCIDENT	██████████
DATE OF NOTICE	7/16/12
MODEL/MODEL YEAR	2012 Jeep Grand Cherokee Laredo 4x4
VIN	1C4RJFAG4CO ██████████
MILEAGE	1,132
OWNER	██
COURT	None
DOCKET #	None
ALLEGED DEFECT DESCRIPTION	Interior Fire The owner stated that he had been driving his vehicle for about 15 to 20 minutes when he smelled a burning odor. He then noticed smoke and flames at the right sun visor. The owner was able to blow out the fire on his own accord. He sustained no injuries.
CRASH	No
PROPERTY DAMAGE	No
INJURIES	0
FATALITIES	0
ANALYSIS	An inspection ¹⁰ of the vehicle revealed that the fire originated in the right side sun visor, under the bracket. The cause appeared to be a pinched vanity mirror wire under the visor bracket which shows signs of arcing and shorting.

¹⁰ The inspection was conducted at the request of counsel in anticipation of litigation and the report is being withheld under a claim of attorney work-product privilege.

MATTER #	[REDACTED]
FILE TYPE	Legal Claim
FILE NAME	[REDACTED]
CAIR #	22474855
DATE OF INCIDENT	[REDACTED]
DATE OF NOTICE	7/30/12
MODEL/MODEL YEAR	2012 Jeep Grand Cherokee Laredo 4x2
VIN	1C4RJEAG6CC [REDACTED]
MILEAGE	5,152
OWNER	[REDACTED]
COURT	None
DOCKET #	None
ALLEGED DEFECT DESCRIPTION	Interior Fire The owner stated that soon after giving his vehicle to a parking attendant to be valet parked, the parking attendant notified him that his vehicle was on fire. The Fire Department was called. No injuries were sustained in the incident.
CRASH PROPERTY DAMAGE	No
INJURIES	No
FATALITIES	0
ANALYSIS	0 An inspection ¹¹ of the vehicle revealed that the fire originated in the right front headliner, visor area. The cause of the fire appeared to be electrical.

¹¹ The inspection was conducted at the request of counsel in anticipation of litigation and the report is being withheld under a claim of attorney work-product privilege.

MATTER #	██████████
FILE TYPE	Legal Claim
FILE NAME	████████████████████
CAIR #	22557049
DATE OF INCIDENT	██████████
DATE OF NOTICE	8/24/12
MODEL/MODEL YEAR	2012 Dodge Durango Crew Awd
VIN	1C4SDJDT2CC ██████████
MILEAGE	1,925
OWNER	████████████████████
COURT	None
DOCKET #	None
ALLEGED DEFECT DESCRIPTION	Interior Fire The owner stated that while driving his wife's vehicle he noticed smoke coming from the right side headliner near the windshield. He stopped the vehicle, removed his children and called the fire department. The smoke stopped when the fire department disconnected the battery. There were no injuries sustained in the incident.
CRASH	No
PROPERTY DAMAGE	No
INJURIES	0
FATALITIES	0
ANALYSIS	An inspection ¹² of the vehicle revealed that the fire originated in the right front sun visor mounting base. The fire appeared to have been caused by the wiring for the front vanity mirror lamps when the right front sun visor was reinstalled following the replacement of the headliner by the selling dealer.

¹² The inspection was conducted at the request of counsel in anticipation of litigation and the report is being withheld under a claim of attorney work-product privilege.

MATTER #	██████████
FILE TYPE	Legal Claim
FILE NAME	████████████████████
CAIR #	22605939
DATE OF INCIDENT	██████████
DATE OF NOTICE	9/10/12
MODEL/MODEL YEAR	2011 Dodge Durango Citadel Awd
VIN	1D4SE5GT5BC ██████████
MILEAGE	11,099
OWNER	████████████████████
COURT	None
DOCKET #	None
ALLEGED DEFECT DESCRIPTION	Interior Fire The owner stated that while driving her vehicle she noticed smoke coming from her sunroof. She stopped her vehicle, opened her sunroof and saw flames in the front of the sunroof on the right side. The owner exited the vehicle with her children, the fire was extinguished and no injuries were sustained a result of the incident.
CRASH	No
PROPERTY DAMAGE	Yes
INJURIES	0
FATALITIES	0
ANALYSIS	An inspection ¹³ of the vehicle revealed that the fire originated in the right sun visor area due to a short in the wiring. The insulation melted on the wiring and the wiring was broken.

¹³ The inspection was conducted at the request of counsel in anticipation of litigation and the report is being withheld under a claim of attorney work-product privilege.

MATTER #	██████████
FILE TYPE	Legal Claim
FILE NAME	██
CAIR #	22904397
DATE OF INCIDENT	██████████
DATE OF NOTICE	12/18/12
MODEL/MODEL YEAR	2013 Jeep Grand Cherokee Laredo 4x4
VIN	1C4RJFAG0DD ██████████
MILEAGE	736
OWNER	██
COURT	None
DOCKET #	None
ALLEGED DEFECT	Interior Fire
DESCRIPTION	The owner stated that his vehicle had been parked for approximately one hour. When he returned to his vehicle he noticed fire in the right front passenger area. He called the fire department and in the meantime attempted to put the fire out with a fire extinguisher. The fire department arrived and put the fire out completely. No injuries were sustained in the incident.
CRASH	No
PROPERTY DAMAGE	No
INJURIES	0
FATALITIES	0
ANALYSIS	An inspection ¹⁴ of the vehicle revealed that the fire originated in the right side visor area. The fire appeared to have been caused by a short to the ground at the mounting screw for the visor/vanity light.

¹⁴ The inspection was conducted at the request of counsel in anticipation of litigation and the report is being withheld under a claim of attorney work-product privilege.

MATTER #	██████████
FILE TYPE	Legal Claim
FILE NAME	██
CAIR #	23166478
DATE OF INCIDENT	██████████
DATE OF NOTICE	3/4/13
MODEL/MODEL YEAR	2012 Jeep Grand Cherokee Laredo 4x4
VIN	1C4RJFAGXCC ██████████
MILEAGE	26,114
OWNER	██
COURT	None
DOCKET #	None
ALLEGED DEFECT DESCRIPTION	Interior Fire The owner stated that while driving his vehicle he smelled something burning, then smoke and flames started coming from the area of the headliner/windshield and sun visor area on the passenger side. He pulled over and called the fire department, but the vehicle received significant fire damage before the Fire Department arrived 20 minutes later. The owner was treated for smoke inhalation and personal items in the vehicle were lost due to the interior fire.
CRASH	No
PROPERTY DAMAGE	Yes
INJURIES	1
FATALITIES	0
ANALYSIS	An inspection ¹⁵ of the vehicle revealed that the fire originated in the right front passenger sun visor area. The fire appeared to have been caused by an electrical short with high resistance heating.

¹⁵ The inspection was conducted at the request of counsel in anticipation of litigation and the report is being withheld under a claim of attorney work-product privilege.

MATTER #	██████████
FILE TYPE	Legal Claim
FILE NAME	████████████████████
CAIR #	23187984
DATE OF INCIDENT	██████████
DATE OF NOTICE	3/11/13
MODEL/MODEL YEAR	2013 Dodge Durango R/t Rwd
VIN	1C4SDHCT1DC ██████████
MILEAGE	357
OWNER	████████████████████
COURT	None
DOCKET #	None
ALLEGED DEFECT	Interior Fire
DESCRIPTION	The owner stated that her dome lights were dim and the passenger side visor vanity lights were not working. A few days after noticing this she entered her garage and smelled smoke. The owner then drove a short distance and got out of her vehicle and saw flames coming from the passenger side sun visor. Her husband then removed the sun visor from the vehicle and put water on it which extinguished the fire before the fire department arrived. The owner's husband burned his right hand while putting out the fire.
CRASH	No
PROPERTY DAMAGE	No
INJURIES	1
FATALITIES	0
ANALYSIS	An inspection ¹⁶ of the vehicle revealed that the fire originated in the passenger sun visor and burned upward into the headliner. The fire appeared to have been caused by a short in the wiring of the passenger side sun visor causing excessive current flow which ignited the visor trim material.

¹⁶ The inspection was conducted at the request of counsel in anticipation of litigation and the report is being withheld under a claim of attorney work-product privilege.

MATTER #	██████████
FILE TYPE	Legal Claim
FILE NAME	████████████████████
CAIR #	23323209
DATE OF INCIDENT	██████████
DATE OF NOTICE	4/15/13
MODEL/MODEL YEAR	2012 Jeep Grand Cherokee Laredo 4x2
VIN	1C4RJEAGXCO ██████████
MILEAGE	24,991
OWNER	████████████████████
COURT	None
DOCKET #	None
ALLEGED DEFECT DESCRIPTION	Interior Fire The owner stated that while driving her vehicle she smelled something but did not think anything of it and purchased an AC vent air freshener. After getting back into her vehicle and driving for a short time she saw smoke coming from the area of the passenger sun visor. The fire then started dripping down onto the passenger seat, starting it on fire. She pulled into a convenience store and called the fire department. Employees from the store came out and extinguished the fire using a fire extinguisher. The fire was put out by the time the fire department arrived. The owner did not sustain any injuries in the incident.
CRASH	No
PROPERTY DAMAGE	No
INJURIES	0
FATALITIES	0
ANALYSIS	An inspection ¹⁷ of the vehicle revealed that the fire originated in the passenger side sun-visor swivel joint. The fire appeared to have been caused by high resistance heat resulting from an electrical short as a result of wires being pinched between the headliner and roof panel.

¹⁷ The inspection was conducted at the request of counsel in anticipation of litigation and the report is being withheld under a claim of attorney work-product privilege.

MATTER #	██████████
FILE TYPE	Legal Claim
FILE NAME	████████████████████
CAIR #	23548432
DATE OF INCIDENT	██████████
DATE OF NOTICE	6/11/13
MODEL/MODEL YEAR	2012 Dodge Durango R/t AWD
VIN	1C4SDJCT1CO ██████████
MILEAGE	2,569
OWNER	████████████████████
COURT	None
DOCKET #	None
ALLEGED DEFECT	Interior Fire
DESCRIPTION	The owner stated that she was at a stop light when she smelled something burning and thought it was coming from outside her vehicle. As she pulled away from the light she noticed smoke near the top edge of the inside driver's side windshield area. She pulled over and at the same time the headliner directly above her ignite into flames. The owner exited the vehicle and smoke soon filled the inside of her vehicle. The fire was extinguished and the owner did not sustain any injuries in the incident.
CRASH	No
PROPERTY DAMAGE	No
INJURIES	0
FATALITIES	0
ANALYSIS	An inspection ¹⁸ of the vehicle revealed that the fire originated in the driver's side sun visor vanity mirror lights. The fire appeared to have been caused by an electrical short inside the driver's side sun visor vanity mirror lighting assembly.

¹⁸ The inspection was conducted at the request of counsel in anticipation of litigation and the report is being withheld under a claim of attorney work-product privilege.

MATTER #	██████████
FILE TYPE	Legal Claim
FILE NAME	████████████████████
CAIR #	23625360
DATE OF INCIDENT	██████████
DATE OF NOTICE	6/28/13
MODEL/MODEL YEAR	2011 Jeep Grand Cherokee Laredo 4x4
VIN	1J4RR4GT8BC ██████████
MILEAGE	26,000
OWNER	████████████████████
COURT	None
DOCKET #	None
ALLEGED DEFECT DESCRIPTION	Interior Fire The owner stated that he was driving for about a half mile when he noticed smoke coming from above the driver's sun visor. He opened the sunroof to ventilate the vehicle, turned the vehicle around and went home. He turned off the ignition, went inside, got a dry chemical extinguisher and put out the fire. He said the fire started as smoke only, but by the time he got the extinguisher he saw flames. The owner was not injured in the incident.
CRASH	No
PROPERTY DAMAGE	No
INJURIES	0
FATALITIES	0
ANALYSIS	An inspection ¹⁹ of the vehicle revealed that the fire originated in the headliner above driver's sun visor. The fire appeared to be consistent with an electrical short circuit. The electrical wiring is the most likely source of ignition of the fire.

¹⁹ The inspection was conducted at the request of counsel in anticipation of litigation and the report is being withheld under a claim of attorney work-product privilege.

MATTER # [REDACTED]
FILE TYPE Legal claim
FILE NAME [REDACTED]
CAIR # 20486934
DATE OF INCIDENT [REDACTED]
DATE OF NOTICE 3/3/2011
MODEL/MODEL YEAR 2011 Jeep Grand Cherokee Overland 4x4
VIN 1J4RR6GT9BC [REDACTED]
MILEAGE 2,000
OWNER [REDACTED]

COURT DOCKET # NA
ALLEGED DEFECT Interior fire

DESCRIPTION The owner stated he went to open the sunroof and noticed smoke from the headliner. He rolled the windows up and the smoke went away. When he rolled the windows down the smoke came back. He drove to nearest Chrysler dealer which was closed, so he went next door to the Ford dealership, when the car caught fire. He called Chrysler roadside assistance to have the vehicle towed to a Chrysler dealer. Owner stated that he had welts on his hands from the fire.

CRASH No
PROPERTY DAMAGE No

INJURIES 1
FATALITIES 0

ANALYSIS Chrysler Group was given no opportunity to inspect the vehicle before repairs were performed by dealer. The Dealer's Repair Order states that the vehicle was towed in due to a fire apparently caused by an electrical short in the headliner. The extent of the damage to the vehicle is not known.

MATTER #	██████████
FILE TYPE	Legal claim
FILE NAME	████████████████████
CAIR #	23858386
DATE OF INCIDENT	██████████
DATE OF NOTICE	8/23/2013
MODEL/MODEL YEAR	2011 Jeep Grand Cherokee Laredo 4x2
VIN	1J4RS4GGXBC ██████████
MILEAGE	20,544
OWNER	████████████████████
COURT	NA
DOCKET #	NA
ALLEGED DEFECT	Interior fire
DESCRIPTION	The owner stated she was driving home when she saw something by the visor that looked like a string. It was white swirly smoke coming from driver side visor. She fanned it and could smell something burning. She pulled over into a service station. She did not see flames. The smoke stopped once the vehicle was turned off. She called her friends who came and they waited about 45 minutes. Her friend who is a mechanic moved the visor and the dome light flickered. ██████████ stated she could see bubbles on bracket at sun visor. Her friend drove the vehicle about 4 miles to dealership and it did not smoke again.
CRASH	No
PROPERTY DAMAGE	No
INJURIES	0
FATALITIES	0
ANALYSIS	An inspection ²¹ of the vehicle revealed pinched/shorted wires going to the visor. There was a small scorch mark at edge of headliner where the sun visor mounts.

²¹ The inspection was conducted at the request of counsel in anticipation of litigation and the report is being withheld under a claim of attorney work-product privilege.



1219596
Gadberry

**Service of Process
Transmittal**

02/23/2011
CT Log Number 518076900



TO: Melissa Gravlin
Chrysler Group LLC
Office Of General Counsel, 1000 Chrysler Drive
CIMS: 485-13-62
Auburn Hills, MI 48326-2766

RE: Process Served in Texas

FOR: Chrysler Group LLC (Domestic State: DE)

ENCLOSED ARE COPIES OF LEGAL PROCESS RECEIVED BY THE STATUTORY AGENT OF THE ABOVE COMPANY AS FOLLOWS:

TITLE OF ACTION: RE: [REDACTED] // To: Chrysler Group, LLC
Name discrepancy noted.

DOCUMENT(S) SERVED: Notice

COURT/AGENCY: None Specified
Case # None Specified

NATURE OF ACTION: Letter of Intent - Threatening Litigation - Offer of settlement in the amount of \$13,500.00 for failure to tender vehicle free of defects and failure to repair under warranties

ON WHOM PROCESS WAS SERVED: C T Corporation System, Dallas, TX

DATE AND HOUR OF SERVICE: By Regular Mail on 02/23/2011 postmarked on 02/18/2011

JURISDICTION SERVED : Texas

APPEARANCE OR ANSWER DUE: Within 60 days

ATTORNEY(S) / SENDER(S): Craig M. Patrick
Patrick Law Firm, P.C.
3333 Lee Parkway
Suite 600
Dallas, TX 75219
214-665-9510

ACTION ITEMS: SOP Papers with Transmittal, via Fed Ex 2 Day , 796792468470
Image SOP

SIGNED: C T Corporation System
PER: Beatrice Casarez
ADDRESS: 350 North St Paul Street
Suite 2900
Dallas, TX 75201
TELEPHONE: 214-932-3601

02/23/2011
11:01 AM
MAIL ROOM

Chrysler Group LLC
Office of the General Counsel

RECEIVED

FEB 25 2011

FEB 25 2011

By MA Mail/Rec. Agent/
Sec. of State/Proc. Server

MILLER, CANFIELD, PADDOCK
AND STONE, P.L.C.

Information displayed on this transmittal is for CT Corporation's record keeping purposes only and is provided to the recipient for quick reference. This information does not constitute a legal opinion as to the nature of action, the amount of damages, the answer date, or any information contained in the documents themselves. Recipient is responsible for interpreting said documents and for taking appropriate action. Signatures on certified mail receipts confirm receipt of package only, not contents.

PATRICK LAW FIRM, P.C.

3333 Lee Parkway, Suite 600
Dallas, Texas 75219
Phone: (214) 665-9510
Fax: (214) 665-9511
Toll Free: 1-888-LEMON-81

CRAIG M. PATRICK
craigpatrick@att.net
Licensed in TX, CA

February 17, 2011

Chrysler Group, LLC
CT Corporation System
350 N. St. Paul St., Suite 2900
Dallas, Texas 75201

Re: [REDACTED]
DTPA Demand Letter
2011 Jeep Grand Cherokee, VIN: 1J4RR6GT9BC [REDACTED] (the "Vehicle")

Greetings:

DTPA NOTICE LETTER

My firm has been retained to represent [REDACTED] with respect to a claim that he has against you. Please direct all communications concerning this matter to me.

On January 22, 2011, my client purchased the above referenced Vehicle from Huffines Chrysler Jeep in Plano, Texas for approximately \$44,000. The product did not conform to the warranties and representations made by Chrysler and its dealers and the applicable warranties have been breached.

The Vehicle has experienced an excessive number of defects and Chrysler and its dealers have been unable to repair the Vehicle in accordance with Chrysler's express warranty. The Vehicle has been repaired at least 5 times, and spent at least 5 days in the shop. The Vehicle has experienced defects with the check engine light, electrical wiring, audio unit, and other defects listed in the warranty repair history. The Vehicle still has defects.

The Vehicle's partial repair history, as reflected in the service records in my client's possession, is as follows:

<u>Mileage</u>	<u>Date</u>	<u># Days</u>	<u>Defect</u>	<u>Repair</u>
512	01/24/11	1	electrical	no update available
621	01/25/11	1	CEL	SOP
919	02/03/11	1	CEL	replace bank 2 converter

Additional repairs may be found in Chrysler's warranty repair history.

It is my contention that Chrysler failed to tender the Vehicle free of defects and its failure to repair the defective Vehicle constitutes a breach of the written and implied warranties covering the Vehicle and is a violation of the MMWA to which Plaintiff is entitled to recover: (1) his damages under 15 U.S.C. § 2310(d)(1) or (2) a full refund under 15 U.S.C. § 2304(a)(4). My client has performed all things agreed to and required under the purchase agreement and warranty, except as may have been excused or prevented by the conduct of Chrysler.

In addition to the protection federal law affords them, my client contends that Chrysler also violated the Texas Deceptive Trade Practices Act.

As a direct and proximate result of Chrysler's violation of its obligations under federal and state law, my client has suffered the following damages:

- A. Cost of repair;
- B. Diminished value of the Vehicle;
- C. Loss of use;
- D. Out of pocket expenses; and
- E. Attorney's fees.

Based on the foregoing, my client demands that Chrysler rescind the transaction by which my client purchased the Vehicle. Upon your agreement to cancel the transaction, my client will return the vehicle to you in exchange for a full refund of the money paid for this vehicle, less a reasonable charge for his use of the Vehicle. Alternatively, my client will accept \$10,000.00 in full and final satisfaction of his claim.

My client has also incurred reasonable and necessary attorney's fees in the pursuit of this claim stated in this letter. The amount of fees incurred as of the date of this letter is \$3,500.00, paid in addition to any repurchase or cash settlement, for a total of **\$13,500**.

Under the contract of employment I have with our client, my firm has been assigned an interest in the claim against you.

OFFER OF SETTLEMENT

The purpose of this letter is to encourage you to resolve my client's claim in a fair and equitable manner without the need for further legal action. In the event you fail to take advantage of this offer of settlement, I will have no alternative but to recommend to my clients that a lawsuit be filed against you under the Magnuson-Moss Warranty Act and the DTPA. In this lawsuit, rather than seeking only the amount of compensation I am asking of you at this time, I will seek to recover the full measure of damages to which our client is legally entitled as well as our client's expenses and attorney's fees as allowed by law.

If you are interested in resolving this matter without the necessity of litigation, please contact me with sufficient time to resolve the dispute within sixty (60) days of your receipt of this letter. Thank you for your attention to this letter.

Very truly yours,

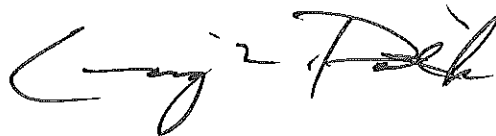
A handwritten signature in black ink, appearing to read "Craig M. Patrick". The signature is written in a cursive style with a large initial "C" and a prominent "P".

Craig M. Patrick

COLUMBUS DIVISION OF FIRE - 3675 Parsons, COLUMBUS, OH 43207 6142213132

A	25009 FDID	OH State	Incident Date	034 Station	INCIDENT NUMBER	000 Exposure	NFIRS -1 Basic
----------	---------------	-------------	---------------	----------------	-----------------	-----------------	---------------------------

B Location	<input type="checkbox"/> See Wildland Fee Module for Location	Census Tract 62.2-0
1 Street address	Number/Inspot Prefix Street or Highway	Street Type Suffix
Apt./Suite/Room	DUBLIN City	OH State
Cross Street or Direction	BLAZER PKWY	Zip Code

C Incident Type 131 Passenger vehicle fire Incident Type	E1 Dates & Times	E2 Shifts & Alarms Local Option																					
D Aid Given or Received N None	<table border="1"> <thead> <tr> <th></th> <th>Date</th> <th>Time</th> </tr> </thead> <tbody> <tr> <td>Dispatch</td> <td>02/03/2012</td> <td>16:35:43</td> </tr> <tr> <td><input checked="" type="checkbox"/> Arrival</td> <td>02/03/2012</td> <td>16:42:11</td> </tr> <tr> <td><input type="checkbox"/> Controlled</td> <td></td> <td>::</td> </tr> <tr> <td><input checked="" type="checkbox"/> Last Unit Cleared</td> <td>02/03/2012</td> <td>17:36:23</td> </tr> </tbody> </table>		Date	Time	Dispatch	02/03/2012	16:35:43	<input checked="" type="checkbox"/> Arrival	02/03/2012	16:42:11	<input type="checkbox"/> Controlled		::	<input checked="" type="checkbox"/> Last Unit Cleared	02/03/2012	17:36:23	<table border="1"> <thead> <tr> <th>Shift or Platform</th> <th>Alarms</th> <th>District</th> </tr> </thead> <tbody> <tr> <td>1</td> <td>1</td> <td>BN7</td> </tr> </tbody> </table>	Shift or Platform	Alarms	District	1	1	BN7
	Date	Time																					
Dispatch	02/03/2012	16:35:43																					
<input checked="" type="checkbox"/> Arrival	02/03/2012	16:42:11																					
<input type="checkbox"/> Controlled		::																					
<input checked="" type="checkbox"/> Last Unit Cleared	02/03/2012	17:36:23																					
Shift or Platform	Alarms	District																					
1	1	BN7																					
		E3 Special Studies Local Option																					
		Special Study Use Special Study Value																					

F Action Taken	G1 Resources	G2 Estimated Dollar Losses & Values												
11 Extinguishment by fire service personnel Primary Action Taken (1) 88 Investigate Additional Action Taken (2) 84 Refer to proper authority Additional Action Taken (3)	<input type="checkbox"/> Check this box and skip this section if an Apparatus or Personnel form is used. <table border="1"> <thead> <tr> <th></th> <th>Apparatus</th> <th>Personnel</th> </tr> </thead> <tbody> <tr> <td>Suppression</td> <td>1</td> <td>4</td> </tr> <tr> <td>EMS</td> <td>0</td> <td>0</td> </tr> <tr> <td>Other</td> <td>1</td> <td>1</td> </tr> </tbody> </table> <input type="checkbox"/> Check box if resource source includes aid received resources.		Apparatus	Personnel	Suppression	1	4	EMS	0	0	Other	1	1	LOSSES: Required for all fires if known. Optional for non fires. None Property \$ 40,000 <input type="checkbox"/> Contents \$ 2,000 <input type="checkbox"/> PRE-INCIDENT VALUE: Property \$ 40,000 <input type="checkbox"/> Contents \$ 2,000 <input type="checkbox"/>
	Apparatus	Personnel												
Suppression	1	4												
EMS	0	0												
Other	1	1												

Completed Modules	H1 Casualties	H3 Hazardous Materials Release	J Mixed Use Property
<input checked="" type="checkbox"/> Fire-3 <input type="checkbox"/> Structure-3 <input type="checkbox"/> Civilian Fire Cas.-4 <input type="checkbox"/> Fire Serv. Casualty-5 <input type="checkbox"/> EMS-6 <input type="checkbox"/> HazMat-7 <input type="checkbox"/> Wildland Fire-8 <input checked="" type="checkbox"/> Apparatus-9 <input type="checkbox"/> Personnel-10 <input type="checkbox"/> Arson-11	<input checked="" type="checkbox"/> None Fire Deaths Injuries Civilian H2 Detector	N None	NN Not mixed use

J Property Use
985 Vehicle parking area

M Authorization	Rank	Assignment	Date
Officer in charge ID R098 Signature AARON K RUCKER			
Check box if same as Officer in charge <input checked="" type="checkbox"/> Member Making Respects ID R098 Signature AARON K RUCKER			02/03/2012

COLUMBUS DIVISION OF FIRE - 3675 Parsons, COLUMBUS, OH 43207 6142213132

Incident: F12018467-000

K1 Person/Entity Involved

Local Option Business name (if applicable) Phone Number

Check this box if same address as incident location. Then skip the three duplicate address lines.

Mr., Ms., Mrs. First Name MI Last Name Suffix

Number Prefix Street or Highway Street Type Suffix

Post Office Box Apt./Suite/Room City

OH Springfield
State Zip Code

K2 Owner

Local Option Same as person involved? Then check this box and skip the rest of this section. Business name (if applicable) Phone Number

Check this box if same address as incident location. Then skip the three duplicate address lines.

Mr., Ms., Mrs. First Name MI Last Name Suffix

Number Prefix Street or Highway Street Type Suffix

Post Office Box Apt./Suite/Room City

OH Springfield
State Zip Code

L Remarks:

Local Option

COLUMBUS DIVISION OF FIRE - 3675 Parsons, COLUMBUS, OH 43207 6142213132

K 25000 OH 02/03/2012 094 Delete NFIRS - 18 Supplemental
FD# State Incident Date Station Incident Number Exposure Change

K3 Person/Entity Involved

Business name (if applicable) Phone Number

Check this box if same address as incident location. Then skip the three duplicate address lines.

Mr., Ms., Mrs. First Name MI Last Name Suffix

Number Prefix Street or Highway Street Type Suffix

Post office box Apt./Suite/Room City

State Zip Code

COLUMBUS DIVISION OF FIRE - 3875 Parsons, COLUMBUS, OH 43207 6142213132

A	25009 FDID	OH State	02/03/2012 Incident Date	034 Station	[REDACTED] Incident Number	000 Exposure	NFIRS - 2 Fire
----------	---------------	-------------	-----------------------------	----------------	-------------------------------	-----------------	---------------------------

<p>B Property Details</p> <p>B1 <input type="checkbox"/> Not Residential Estimated number of residential living units in building of origin whether or not all units became involved</p> <p>B2 <input type="checkbox"/> Buildings not involved Number of buildings involved</p> <p>B3 <input type="checkbox"/> None <input type="checkbox"/> Less than one acre Acreage burned (outside fires)</p>	<p>C On-Site Materials or Products <input checked="" type="checkbox"/> None</p> <p>On-site material (1) <input type="checkbox"/></p> <p>On-site material (2)</p> <p>On-site material (3)</p>
--	---

<p>D Ignition</p> <p>D1 B1 Operator/passenger area of transportation Area of fire origin</p> <p>D2 UU Undetermined Heat source</p> <p>D3 UU Undetermined Item first ignited <input type="checkbox"/> Check box if fire spread was confined to object of origin</p> <p>D4 UU Undetermined Type of material first ignited <small>Required only if item first ignited code is 02 or 470</small></p>	<p>E1 Cause of ignition <input type="checkbox"/> Check box if this is an exposure report. 5 <input checked="" type="checkbox"/> Cause under investigation</p> <p>E2 Factors Contributing to Ignition <input type="checkbox"/> None</p> <p>Factor contributing to ignition (1)</p> <p>Factor contributing to ignition (2)</p>	<p>E3 Human Factors Contributing to Ignition</p> <p>1 <input type="checkbox"/> Asleep 2 <input type="checkbox"/> Possibly impaired by alcohol or drugs 3 <input type="checkbox"/> Unattended person 4 <input type="checkbox"/> Possibly mentally disabled 5 <input type="checkbox"/> Physically disabled 6 <input type="checkbox"/> Multiple persons involved</p> <p>7 <input type="checkbox"/> Age was a factor</p> <p>Estimated age of person involved</p> <p>1 <input type="checkbox"/> Male 2 <input type="checkbox"/> Female</p>
---	--	--

<p>F1 Equipment Involved in Ignition <input checked="" type="checkbox"/> None <small>If equipment was not involved, skip to Section G</small></p> <p>Equipment involved</p> <p>Brand</p> <p>Model</p> <p>Serial #</p> <p>Year</p>	<p>F2 Equipment Power UU Undetermined Equipment Power Source</p> <p>F3 Equipment Portability 1 <input checked="" type="checkbox"/> Portable <small>Portable equipment normally can be moved by one person, is designed to be used in multiple locations, and requires no tools to install.</small></p>	<p>G Fire Suppression Factors Enter up to three codes. <input type="checkbox"/> None</p> <p>Fire suppression factor (1)</p> <p>Fire suppression factor (2)</p> <p>Fire suppression factor (3)</p>
--	--	--

<p>H1 Mobile Property Involved <input type="checkbox"/> None 3 <input checked="" type="checkbox"/> Involved in ignition and burned</p>	<p>H2 Mobile Property Type & Make</p> <p>11 Automobile, passenger car, ambulance, Mobile property type</p> <p>DD Dodge Mobile property make</p>	<p>Local Use <input type="checkbox"/> Pre-Fire Plan Available</p> <p><small>Some of the information presented in this report may be based upon reports from other agencies.</small></p> <p><input type="checkbox"/> Arson report attached <input type="checkbox"/> Police report attached <input type="checkbox"/> Coroner report attached <input type="checkbox"/> Other reports attached</p>
---	--	---

<p>DURANGO Mobile property model</p> <p>License Plate Number</p>	<p>2012 Year</p>	<p>OH 1C4RDJDG8CC [REDACTED] State VIN Number</p>
---	----------------------	--

Columbus Division of Fire Fire Investigations 300 North 4 th Street Columbus, Ohio 43215		INVESTIGATION REPORT	
Incident #: [REDACTED]	Date: 2/3/12	Time: 1635	Type: Accidental
Property Description: 2012 Dodge Durango		Estimated Loss: 8,000.00	
Address: [REDACTED]		Property Type: Automobile	

Owner Information:

[REDACTED]
 [REDACTED]
 Springfield, Ohio [REDACTED]
 [REDACTED]

Vehicle Description:

Year: 2012
 Make: Dodge
 Model: Durango
 Lic: FLM6172
 Vin: 1C4RDJDG8CC [REDACTED]

Insurance Carrier:

Westfield Insurance

Evidence Collected:

None

Photos Taken:

Investigator Jeffrey Smith

Scene Examination:

On 2/3/12 at approximately 16:35 hours, Engine 34 responded to report of a vehicle fire at [REDACTED]. Upon their arrival they found a 2012 Dodge Durango parked in the parking lot of J.C. Penney's with fire, heat, and smoke damage to the interior compartment. Engine 34 crew extinguished and contained the fire and the officer in charge called for an Investigator.

Upon my arrival I spoke to Lt. Rucker who was in charge. He stated that the vehicle's interior area was on fire upon their arrival and that the owners were on scene. My investigation revealed that the fire started in the interior area at the passenger's side sun visor light area. The fire spread upward and outward to cause fire, heat, and smoke damage to the interior. I photographed and documented the scene and then talked to the owners.

Incident #: [REDACTED]

Incident Address: [REDACTED]

Page 2

Interviews:

I spoke to [REDACTED] the owners, who stated they drove from Springfield to the Tuttle Mall area to do some shopping. They stated at their first stop they noticed something that smelled like plastic burning. They finished shopping at that store and then drove to J.C. Penney's to do some more shopping. As they finished shopping at this store they went outside to find their vehicle on fire. [REDACTED] stated he saw fire in the ceiling area on the passenger side and called 911. I advised [REDACTED] of what I found and [REDACTED] stated that the passenger's sun visor light had not worked since they purchased the vehicle.

Conclusion:

This is an accidental fire.

Signed:

Jeffrey Smith, Fire Investigator

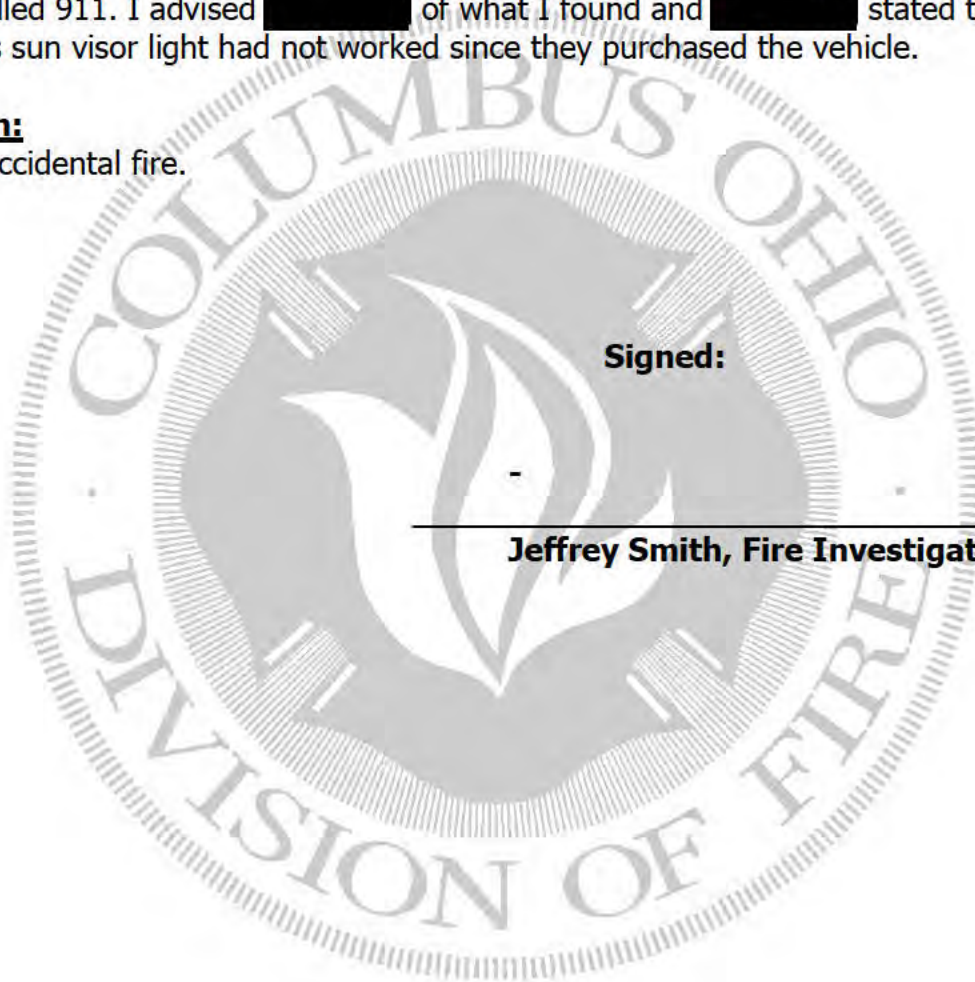



Farmington Casualty Company
.O. Box 3022
Fall River, MA 02721
(800)925-7693

03/01/2012

Chrysler
Rajya Garnepudi
1000 Chrysler Dr
CIMS 485 13 32
Auburn Hills, MI 48326

Our Client: [REDACTED]
Claim/File #: [REDACTED]
Date of Loss: 12/21/2011
Your Insured: N/A
Your File #: 1226975
Reference: Subrogation Claim

Dear Ms. Garnepudi:

We are managing a claim on behalf of [REDACTED], which sustained damages on 12/21/2011. Our investigation of the incident has revealed that your insured is liable for damages.

Farmington Casualty Company has made payments of \$2,334.30 to date for this loss. We are requesting reimbursement from you this amount and for an additional \$500.00 to cover the deductible paid by [REDACTED]. Please remit a total of \$2,834.30 at your earliest convenience.

We will forward the deductible amount to [REDACTED], and will expect to receive payment from you within 30 days.

In order to ensure proper processing, please remit payment to the following address:

Travelers Claims Hartford Auto
PO BOX 660339
Dallas TX 75266-0339

We appreciate your prompt attention in this matter.

Sincerely,
Lisa Abbatematteo
Tech Spec
(508)324-8306
Fax: (866)304-7031
Email: LABBATEM@travelers.com

PE13-027

CHRYSLER

10-7-2013

ENCLOSURE 4

Consumer Complaints Report

Customer Assistance Inquiry Record (CAIR)# 19860838

VIN	1J4RR5GT0 BC [REDACTED]	Open Date	08/23/2010	Built Date	06/11/2010
Model Year	2011	Body	WKJP74	JEEP GRAND CHEROKEE LIMITED 4X4 SPORT UTILITY	
In Service Dt	06/14/2010	Mileage	500	Dealer Zone	32 NEW YORK
Plant	C	JEFFERSON NORTH ASSEMBLY PLANT	Market	U	US
Color	PBV	BLACKBERRY PEARL COAT			
Engine	EZH	5.7L V8 MDS VVT ENGINE			
Transmission	DGQ	5-SPD AUTOMATIC 545RFE TRANSMISSION			

Dealer 44781 DANBURY DODGE

Dealer Address 100B FEDERAL ROAD

Dealer City DANBURY **Dealer State** CT **Dealer Zip** 06810

Owner [REDACTED] **Contact Type** TELEPHONE

Address [REDACTED] **Home Phone**

DANBURY CT [REDACTED] **Country** UNITED STATES

Corporate - Property Damage - Default - Default - Default	
Corporate - Repurchase - Default - Default - Default	
Dealer - By-Pass - Default - Default - Default	
Product - Unknown - Unknown - Fire - Unknown	

- Who is calling and what is their contact information? SM [REDACTED]
Preferred [REDACTED] Main number
Alternate [REDACTED] Service manager Paul
- What happened? Sm manager stated unsold vehicle was being used for a demo and the caught on fire.
- What is the current location of the vehicle? The vehicle is currently at dealership 44781

08.23.10
VEHICLE LOCATED AT:
DANBURY CHRYSLER JEEP DODGE
100B FEDERAL ROAD
DANBURY CT 06810
203-730-5737

PLEASE CONTACT AND ARRANGE INSPECTION TO DETERMINE CAUSE OF LOSS.
PLEASE PROVIDE FULL FIRE REPORT, PHOTOS, POLICE/FIRE DEPT REPORT
(if available) AND ANY OTHER PERTINENT INFORMATION. THANKS, MG17
CAIR NUMBER 19860838 REQUEST EAA INSPECTION 08-23-2010 16:48
CAIR NUMBER 19860838 E-MAIL SENT TO EAA 08-23-2010 16:48
PHOTOGRAPHIC IMAGES POSTED TO THIS CAIR ON 08/30/10 AT 04:25:44 19860838

08. .10
Reviewed EAA report and photos
BUY BACK REQUEST / Dealer DEMO
Reviewed EAA report and photos
Fire Started at the connector for the Sun roof motor. Wiring was not installed properly causing a short in the connector.

There were 2 child safety seats also damaged.

Contact person is Service Manager [REDACTED]

' Preferred [REDACTED] Main number

Alternate [REDACTED] Service manager Paul'

8/31/2010: writer spoke with [REDACTED] at Danbury Dodge. He will provide

writer with MSO, factory invoice and a list of items that were

destroyed/damaged in the fire. He will fax asap.....tgr

09/01/10 FIRE- emailed Tim Bauer with Chrysler to review photos to see if

part out or estimate is needed for possible repair. kl

09/02/10 Per email from Tim Bauer with Chrysler, sell for parts. kl

9/2/2010: writer left a message for [REDACTED] at Danbury Dodge

informing him that writer never received the MSO, factory invoice and a

list of items that were destroyed/damaged in the fire. Writer requested

he please fax asap.....tgr

9/8/2010: writer left another message for [REDACTED] at Danbury Dodge inf

orming him that writer never received the MSO, factory invoice and a list

of items that were destroyed/damaged in the fire. Writer requested he ple

ase fax asap.....tgr

9/13/2010: partially worked case. Trying to obtain receipts for items

destroyed in fire.....tgr

Hold placed on disposal per request from CCRG.

9/15/2010: writer spoke with dealer [REDACTED] late yesterday and was

informed that customer is trying to locate receipts. Customer recently

moved and has no idea where they are at this time..tgr

9/17/2010: never received a call back from mg17 at Chrysler. Writer worked

package and submitted it for approval with reimbursing half the cost of th

e items informed were destroyed/damaged and full cost of the childrens car

seats (170) as indicated by fire investigator.....tgr

9/20/10 Check package approved. CM

9/20/2010: left message for customer to review purchase numbers....tgr

9/21/2010: customer approved figures and check requested.....tgr

9/21/10 Submitted check request to Chrysler for approval. CM

9/29/2010: mailed final documents to Paul Traina at Danbury Dodge....tgr

10/4/2010: vehicle releasable and to-do forwarded to the title department..

..tgr

Part out 10/05/10 Per emailed response to Tim Bauer with Chrysler from

Ron Leach 'I m working with the BC trying to arrange a second inspection.

As soon as I hear (hopefully today) back from the BC I will let you

know.' kl

Part out 10/12/10 Per emailed forwarded by Tim Bauer with Chrysler from

Ron Leach 'Just to update you. I received photos today from the subject

vehicle and passed them on to engineering. Also, I asked if they would

like the vehicle returned to etc, they need to let me know otherwise the

vehicle will be scrapped. I ll give them a few days to respond, and then

we can move forward and scrap if I don t hear from them.' kl

Part out 10/19/10 Emailed Tim Bauer with Chrysler to see if engineering

has decided they want the vehicle or not. kl

Part out 10/19/10 Per email from Tim Bauer with Chrysler 'I spoke with

Ron Leach about it just now and he will give the Engineer who wanted it

one last call. He said they did not reply to his last note he sent them

last week. Says if he doesn t hear anything from them within 24 hrs.,

we should go ahead and scrap it.' kl

10/20/10 Per email from Tim Bauer with Chrysler 'Per Ron Leach, please

move forward with sending this vehicle to LKQ.' kl

Part out 10/20/10 Faxed tow to LKQ. kl

Customer Assistance Inquiry Record (CAIR)# **20198342**

VIN	1J4RS4GG7 BC [REDACTED]	Open Date	12/02/2010	Built Date	08/10/2010
Model Year	2011	Body	WKTH74	JEEP GRAND CHEROKEE LAREDO 4X2 SPORT UTILITY	
In Service Dt	10/11/2010	Mileage	500	Dealer Zone	66 ORLANDO
Plant	C	JEFFERSON NORTH ASSEMBLY PLANT	Market	U	US
Color	PAV	DK. CHARCOAL PEARL COAT			
Engine	ERB	3.6L V6 24V VVT ENGINE			
Transmission	DGJ	5-SPEED AUTO W5A580 TRANSMISSION			

Dealer 60338 AIRPORT CHRYSLER DODGE JEEP

Dealer Address 5751 EAGLE VAIL DR

Dealer City ORLANDO **Dealer State** FL **Dealer Zip** 32822

Owner [REDACTED] **Contact Type** ROADSIDE

Address [REDACTED] **Home Phone** [REDACTED]

ALTAMONTE SPRING FL [REDACTED] **Country** UNITED STATES

Product - Unknown - Unknown - Fire - Interior	Passanger visor started on fire
Corporate - Outbound - Corporate Initiative - Default - Default	WKRS11 Follow Up
Product - Electrical - Unknown - Steam or Smoke - Default	pigtail near vanity lamps shorted
Dealer - By-Pass - Default - Default - Default	

****Begin structured narrative T2 - Beginning Narrative

Briefly summarize why the customer is contacting Chrysler:
 Dealer is calling in on behalf of the customer after the visor started on fire.

Briefly summarize what the customer is expecting:
 Dealership wanted to get a special investigations started.

****End structured narrative T2 - Beginning Narrative

1. Who is calling and what is their contact information? Service manager at Dealer, Craig

Preferred at dealer: 407-541-6200

Alternate customer : [REDACTED]

2. What happened? Customer got into car in garage when to open sunroof and the left side visor started smoking. Dealership towed the vehicle in and did an inspection and found the the wiring harness started the visor on fire damaging the visor and roof

3. What is the current location of the vehicle? Dealer 60338 AIRPORT CHRYSLER DODGE JEEP

12/3 Owner was contacted today. Owner stated he never seen Flames or even Sparks but just smoke near the visor (driver).

***** WKRS11 Follow Up *****

Spoke with owner provided my direct line today. He advised no flames or Sparks and there were no injuries or property damages to report to Chrysler. Agent spoke with SA Craig Smith. SA explained he never reported a fire either. SA advised that this was a wiring short and they ordered parts for the repair. SA explained that pigtail cord lead to the vanity lamps was found twisted around a liner bolt and this is what caused the smoke and short in circuit. I spoke with owner and assured

him we can repair this per terms of mfg warrt, and provide a courtesy
loaner car until repaired (rental provided 10 days @ \$40).

12/7 Called Advisor this morning he advises that parts needed for the
repair are in transit upon completion of the repair order would contact
me back and let me know once it repaired and completed. Direct line
supplied to dealer. SA Craig Smith advised he d follow up.

12/9 Spoke with Parts Manager this morning. Reviewed the following
part numbers 1) VISOR

1LS25HDAAD, 2) 1TH79HDAAA Head Liner, 3.) 5108107AB. Order Number is
listed as ORDER NUMBER: C1203A. There is no listed back order
on these already ordered parts. Part was however ordered under
Daily 'E'. I ve informed the PM to contact me directly should order not
completely be filled by Fri/Sat of this wk.

12/10 Brent Parts manager advised parts arrived today for the necessary
repairs. Owner was informed. Will follow up with the Customer sometime
after repair.

12/13 Service advising repair will be completed today. Called
Owner asked upon his return he call me to let me know of any further
concern.

Customer Assistance Inquiry Record (CAIR)#

20281946

VIN	1J4RR4GG4 BC [REDACTED]	Open Date	01/03/2011	Built Date	10/15/2010
Model Year	2011	Body	WKJH74	JEEP GRAND CHEROKEE LAREDO 4X4 SPORT UTILITY	
In Service Dt	11/01/2010	Mileage	1,700	Dealer Zone	32 NEW YORK
Plant	C	JEFFERSON NORTH ASSEMBLY PLANT	Market	U	US
Color	PXR	BRILLIANT BLACK CRYSTAL PEARL COAT			
Engine	ERB	3.6L V6 24V VVT ENGINE			
Transmission	DGJ	5-SPEED AUTO W5A580 TRANSMISSION			
Dealer	65674	EAST HILLS CHRYSLER JEEP DODGE			
Dealer Address	2300 NORTHERN BLVD				
Dealer City	GREENVALE	Dealer State	NY	Dealer Zip	11548
Owner	[REDACTED]	Contact Type	TELEPHONE		
Address	[REDACTED]	Home Phone	[REDACTED]		
	NEW YORK NY [REDACTED]	Country	UNITED STATES		

Product - Unknown - Unknown - Fire - Interior	Customer states fire started inside liner visor in the vehicle.
Product - Electrical - Lamps and Switches - Intermittent or Inoperative - Default	Customer states no interior lights on, dealer fixed.
Product - Electrical - Wipers / Washers - Complete Failure - Front	Customer states not working, dealer fixed.
Corporate - Property Damage - Default - Default - Default	
Product - Unknown - Unknown - Fire - Unknown	

1. Who is calling and what is their contact information? [REDACTED].

Preferred: Work: [REDACTED]: 268.

Alternate: None.

2. What happened?

[REDACTED] called, states had electronic wipers not working, no interior lights, brought to dealer 65674 East Hills Chrysler Jeep Dodge who indicated a short in the wiring, fixed on 12/13/2010, picked up vehicle on 12/14/201, thereafter drove vehicle on 12/15/2010, customer said he started to smell burning wires inside the vehicle, then vehicle caught on fire inside starting in the visor and liner interior of the vehicle, fire department put out fire and towed to the 65674 East Hills Chrysler Jeep Dodge dealership, vehicle insurance looked at vehicle, vehicle is sitting at the dealership, customer said he was in the vehicle with father, his father said he felt funny inside due to the fumes but is okay, did not go to the hospital due to felt fine afterwards.

3. What is the current location of the vehicle?

65674 East Hills Chrysler Jeep Dodge
2300 Northern Blvd
Greenvale NY 11548
Phone contact: 516-621-9191

Per OGC Matrix, reassigned to 82T.
1/5/11 ASSIGN TO RLG92.

CAIR NUMBER 20281946 REQUEST EAA INSPECTION 01-05-2011 11:31
CAIR NUMBER 20281946 E-MAIL SENT TO EAA 01-05-2011 11:31
CCRG Open Date: 01/05/2011 08:19:37
Letter Sent: Acknowledgement 01/06/2011 08:53:02
PHOTOGRAPHIC IMAGES POSTED TO THIS CAIR ON 01/07/11 AT 18:16:54 20281946
CCRG Close Date: 01/10/2011

Customer Assistance Inquiry Record (CAIR)#**20493744**

VIN	1J4RR6GT9	BC [REDACTED]	Open Date	03/04/2011	Built Date	01/07/2011
Model Year	2011	Body	WKJS74	JEEP GRAND CHEROKEE OVERLAND 4X4 SPORT UTILITY		
In Service Dt	01/22/2011	Mileage	2,000	Dealer Zone	63	DALLAS
Plant	C	JEFFERSON NORTH ASSEMBLY PLANT	Market	U	US	
Color	PDM	MINERAL GRAY MET. CLEAR COAT				
Engine	EZH	5.7L V8 MDS VVT ENGINE				
Transmission	DGQ	5-SPD AUTOMATIC 545RFE TRANSMISSION				
Dealer	67703	HUFFINES CHRYSLER JEEP DODGE				
Dealer Address	4500 W PLANO PKWY					
Dealer City	PLANO	Dealer State	TX	Dealer Zip	75093	
Owner	[REDACTED]			Contact Type	TELEPHONE	
Address	[REDACTED]			Home Phone	[REDACTED]	
	EDMOND OK [REDACTED]			Country	UNITED STATES	

Product - Body / Trim / Paint Finish - Body Hardware - Other - Roof	Sunroof
Product - Electrical - Body Wiring - Burned Out - Default	electrical short in headliner
Corporate - Property Damage - Default - Default - Default	
Dealer - By-Pass - Default - Default - Default	
Product - Unknown - Unknown - Fire - Interior	
Product - Unknown - Unknown - Fire - Unknown	

Briefly summarize why the customer is contacting Chrysler:

Customer states that he was driving down the road coming from Oklahoma to Dallas.

Goes to open sunroof and notices smokes from the headliner, rolled window up smoke goes away, rolled windows down and smoke came back.

Customer states that he went to nearest dealer and they were closed, so he went next door to the ford dealership, when the car caught fire.

Customer calls Chrysler roadside and was towed to Huffines

Short started where the headliner

Customer states that he has welts on his hands from the fire

Customer states that he does not feel safe with this vehicle and does not want another jeep.

Please see cair 20486934, this cair was documented by dealer however looks as though it has been closed.

Briefly summarize what the customer is expecting:

Customer wants the vehicle bought back

Customer states that the fire was a manufacturer defect

Customer was advised that due to the nature of their contact a call back is required and will take place within one business day by COB their time.

Preferred call back number is [REDACTED] cell

Who has possession of the vehicle? (Dealer)

Has the vehicle been diagnosed by a CDJ dealer? (Yes)

If a CDJ dealer has diagnosed, what is the dealer name or code? 67703

Reassigned to 88I

Correction to line 25

Reassigned to 88S

1. Who is calling and what is their contact information?

██████████ calls in

Preferred ██████████

2. What happened?lines 2-9

3. What is the current location of the vehicle?Huffines dealer code 67703

This issue is already being addressed on Cair 20486934. (just because the Cair is closed doesn't mean the file is closed)

Customer Assistance Inquiry Record (CAIR)# **21131293**

VIN	1J4RR4GT5 E [REDACTED]	Open Date	07/20/2011	Built Date	07/27/2010
Model Year	2011	Body	WKJH74	JEEP GRAND CHEROKEE LAREDO 4X4 SPORT UTILITY	
In Service Dt	12/17/2010	Mileage	9,900	Dealer Zone	74 DENVER
Plant	C	JEFFERSON NORTH ASSEMBLY PLANT	Market	U	US
Color	PGN	NATURAL GREEN PEARL COAT			
Engine	EZH	5.7L V8 MDS VVT ENGINE			
Transmission	DGQ	5-SPD AUTOMATIC 545RFE TRANSMISSION			

Dealer 68978 LUTHER BROOKDALE CHRY-JEEP

Dealer Address 8188 BROOKLYN BLVD

Dealer City BROOKLYN PARK **Dealer State** MN **Dealer Zip** 55445

Owner [REDACTED] **Contact Type** ROADSIDE

Address [REDACTED] **Home Phone** [REDACTED]

COON RAPIDS MN [REDACTED] **Country** UNITED STATES

Corporate - Property Damage - Default - Default - Default	
Corporate - Roadside Services - Warranty - Vehicle Inoperable - Default	
Dealer - By-Pass - Default - Default - Default	
Product - Unknown - Unknown - Fire - Interior	
Product - Unknown - Unknown - Fire - Unknown	

Roadside Assistance Contacted - DATE : 2011-07-20
 Road Side File Created 07-20-11 FOR WARRANTY
 VEHICLE PROBLEM AT: VEHICLE TAKEN TO:
 17225 HIGHWAY 55 8188 BROOKLYN BLVD
 CONNECTING ROAD
 PLYMOUTH BROOKLYN PARK
 MN USA MN
 GREEN VEHICLE BURNT. PUT OUT BY FIRE DEPARTMENT. B
 DEALER CODE : 68978 LUTHER BROOKDALE CHRY-JEEP
 07/20/11 Received a call from dealership 68978 this morning stating that
 this vehicle had been towed in over night with a headliner fire near the
 top of the windshield. Forwarding CAIR to JSS15 for investigation and
 follow-up./ajb2

VEHICLE IS LOCATED AT:
 LUTHER BROOKDALE CHRY-JEEP CJDT
 8188 BROOKLYN BLVD BROOKLYN PARK MN 55445 763-535-5200

Per OGC Matrix, reassigned to 82T.
 (photos provided by AM via email uploaded to CPS)
 PHOTOGRAPHIC IMAGES POSTED TO THIS CAIR ON 07/20/11 AT 13:32:59 21131293
 7/20/11 ASSIGNED TO RLG92
 CAIR NUMBER 21131293 REQUEST DEKRA INSPECTION 07-20-2011 14:25
 CAIR NUMBER 21131293 E-MAIL SENT TO DEKRA 07-20-2011 14:25
 CCRG Open Date: 07/20/2011 13:24:53
 Letter Sent: Acknowledgement 07/21/2011 08:44:03

PHOTOGRAPHIC IMAGES POSTED TO THIS CAIR ON 07/27/11 AT 15:35:52 21131293

Customer Assistance Inquiry Record (CAIR)# **21686117**

VIN	1J4RR4GG2 B [REDACTED]	Open Date	12/21/2011	Built Date	06/23/2011
Model Year	2011	Body	WKJH74	JEEP GRAND CHEROKEE LAREDO 4X4 SPORT UTILITY	
In Service Dt	09/03/2011	Mileage	8,266	Dealer Zone	35 WASHINGTON
Plant	C	JEFFERSON NORTH ASSEMBLY PLANT	Market	U	US
Color	PWL	WHITE GOLD CLEAR COAT			
Engine	ERB	3.6L V6 24V VVT ENGINE			
Transmission	DGJ	5-SPEED AUTO W5A580 TRANSMISSION			

Dealer	43232	JEFF D'AMBROSIO CHRYSLER JEEP	DODGE
---------------	-------	-------------------------------	-------

Dealer Address	1221 E LANCASTER AVE		
-----------------------	----------------------	--	--

Dealer City	DOWNINGTOWN	Dealer State	PA	Dealer Zip	19335
--------------------	-------------	---------------------	----	-------------------	-------

Owner	[REDACTED]	Contact Type	TELEPHONE
--------------	------------	---------------------	-----------

Address	[REDACTED]	Home Phone	[REDACTED]
----------------	------------	-------------------	------------

COATESVILLE PA [REDACTED]	Country	UNITED STATES
---------------------------	----------------	---------------

Product - Unknown - Unknown - Fire - Unknown	unknown
Corporate - Property Damage - Default - Default - Default	
Dealer - By-Pass - Default - Default - Default	

****Begin structured narrative T2 - Beginning Narrative
 Briefly summarize why the customer is contacting Chrysler:
 Briefly summarize what the customer is expecting:
 ****End structured narrative T2 - Beginning Narrative
 Who is calling and what is their Contact Information? Warranty Admin/
 Service Adimn: Denise May called from dealer code #43232 Jeff D ambrosio
 Chrysler Jeep telephone: 610-269-9500 ext 222, Denise s direct line.
 What Happened? Denise called on behalf of the client [REDACTED],
 Denise states the customer s vehicle caught on fire. No injuries to the
 knowledge of Service Administrator Denise. New Vehicle current mileage
 noted at roughly at 8266 miles. VIN: bc [REDACTED]
 Per Denise: customer was at a clients house and during the visit,
 customer noticed his car was on fire.
 What is the Current location of the vehicle? Jeff D Ambrosio Chrysler
 Jeep Dodge
 1221 e Lancaster ave
 Downingtown, PA 19335-5369
 Telephone: 610-269-9500
 forwarded to 88S
 Customer telephone contact: 610-384-1723

 12.22.11
 >> case is being forwarded to Chrysler Legal (CCRG) (2-5 days contact)
 VEHICLE LOCATED AT:
 JEFF D AMBROSIO CHRYSLER JEEP
 1221 E LANCASTER AVE
 DOWNINGTOWN PA 19335
 610-269-9500

Per OGC Matrix, reassigned to 82T. MG17
12/22/11 ASSIGNED TO RLG92.
CAIR NUMBER 21686117 REQUEST EAA INSPECTION 12-22-2011 14:19
CAIR NUMBER 21686117 E-MAIL SENT TO EAA 12-22-2011 14:20
CCRG Open Date: 12/22/2011 08:17:36
Letter Sent: Acknowledgement 12/23/2011 08:32:12
PHOTOGRAPHIC IMAGES POSTED TO THIS CAIR ON 12/28/11 AT 16:12:08 21686117
Briefly summarize why the customer is contacting Chrysler:
Briefly summarize what the customer is expecting:
Lisa Young from Travelers insurance called today to check the status of
the claim
Agent used answer connect and provided maggies number and reassigned the
CAIR to 82S
Lisa s would like a call back at: 800-842-9897 ext. 3964, Claim number:

██████████

Per OGC Matrix, reassigned to 82T.
1/3/12 UPDATED CCRG FILE & CASE MANAGER. PAG

Customer Assistance Inquiry Record (CAIR)#

21747059

VIN	1C4RJFCG2	CC [REDACTED]	Open Date	01/09/2012	Built Date	09/08/2011
Model Year	2012	Body	WKJS74	JEEP GRAND CHEROKEE OVERLAND 4X4 SPORT UTILITY		
In Service Dt	11/03/2011	Mileage	2,300	Dealer Zone	35	WASHINGTON
Plant	C	JEFFERSON NORTH ASSEMBLY PLANT		Market	U	US
Color	PW1	STONE WHITE CLEAR COAT				
Engine	ERB	3.6L V6 24V VVT ENGINE				
Transmission	DGJ	5-SPEED AUTO W5A580 TRANSMISSION				
Dealer	60193	NORTHSIDE CHRYSLER JEEP DODGE, LLC				
Dealer Address	812 NORTHSIDE DR					
Dealer City	SUMMERSVILLE	Dealer State	WV	Dealer Zip	26651	
Owner	[REDACTED]				Contact Type	TELEPHONE
Address	[REDACTED]				Home Phone	[REDACTED]
	SUMMERSVILLE WV [REDACTED]				Country	UNITED STATES

Dealer - By-Pass - Default - Default - Default	Interior Roof Fire
Product - Electrical - Unknown - Other - Default	Interior Roof Fire
Product - Unknown - Unknown - Fire - Interior	Roof fire
Corporate - Property Damage - Default - Default - Default	
Product - Unknown - Unknown - Fire - Unknown	

Briefly summarize why the customer is contacting Chrysler: Customer called stating the ceiling in his vehicle caught fire. The customer believes it to be electrical.

Briefly summarize what the customer is expecting: Customer is expecting an investigation.

Who is calling and what is their Contact Information? [REDACTED]

What Happened? Interior ceiling caught fire.

What is the Current location of the vehicle? J and J wreckers.

304-872-0952
 J&J Wreckers
 3664 Canvas Nettie Rd.
 Canvas, WV 26662
 File referred to 82S

 Per OGC Matrix, reassigned to 82T.
 1/9/12 ASSIGNED TO RLG92. PAG
 CAIR NUMBER 21747059 REQUEST EAA INSPECTION 01-09-2012 15:55
 CAIR NUMBER 21747059 E-MAIL SENT TO EAA 01-09-2012 15:55
 Lorrie Croston Erie Insurance Group 304-457-5995 request a call from Case Manager PAG45
 Reassigned to 82T
 1/10/12 UPDATED CCRG FILE & CASE MANAGER. PAG
 CCRG Open Date: 01/09/2012 15:20:33
 Letter Sent: Acknowledgement 01/10/2012 09:41:31
 PHOTOGRAPHIC IMAGES POSTED TO THIS CAIR ON 01/11/12 AT 10:18:57 21747059
 PHOTOGRAPHIC IMAGES POSTED TO THIS CAIR ON 01/11/12 AT 11:13:35 21747059

Customer Assistance Inquiry Record (CAIR)#**21850450**

VIN	1C4RDJDG8	CO [REDACTED]	Open Date	02/06/2012	Built Date	07/26/2011
Model Year	2012	Body	WDEH75	DODGE DURANGO CREW AWD SPORT UTILITY 4-DR		
In Service Dt	12/30/2011	Mileage	100	Dealer Zone	42	DETROIT
Plant	C	JEFFERSON NORTH ASSEMBLY PLANT	Market	U	US	
Color	PXR	BRILLIANT BLACK CRYSTAL PEARL COAT				
Engine	ERB	3.6L V6 24V VVT ENGINE				
Transmission	DGJ	5-SPEED AUTO W5A580 TRANSMISSION				
Dealer	42399	BILL MARINE CHRY-DODGE-JEEP				
Dealer Address	1182 W MAIN STREET					
Dealer City	WILMINGTON			Dealer State	OH	Dealer Zip 45177
Owner	[REDACTED]				Contact Type	TELEPHONE
Address	[REDACTED]				Home Phone	[REDACTED]
	SPRINGFIELD OH [REDACTED]				Country	UNITED STATES

Corporate - Product Information - Default - Default - Default	Dealer called to start special investigation
Product - Unknown - Unknown - Fire - Instrument Panel	vehicle caught fire on February 3, 2012
Corporate - Property Damage - Default - Default - Default	
Dealer - By-Pass - Default - Default - Default	
Product - Unknown - Unknown - Fire - Unknown	

Briefly summarize why the customer is contacting Chrysler: Dealer called on behalf of customer to start a special investigation case. Agent advised the dealer that we ask for the customer to be the one calling to create case. Dealer stated that he would call the customer to have them call in.

Briefly summarize what the customer is expecting: Dealer seeking to start special investigation.

1. Who is calling and what is their contact information?

Preferred: [REDACTED]

Alternate: [REDACTED]

2. What happened?

Customer stated they went into a shopping mall, and came back out to the parking lot about 20 min later to find the interior of the vehicle engulfed in flames. The fire marshal states that the fire appears to have started from the interior/upper console.

To contact fire marshal for copy of the report into the fire please contact Fire Marshall s name is Jeff Smith, phone number 614-645-3011, fax number 614-645-7684, email address smithjl@columbus.gov www.columbus.gov or the Fire and Bomb Investigations, 300 N 4th street, Columbus, OH, 43215

3. What is the current location of the vehicle?

Bill Marine Auto (Chrysler dealership)
420 E Columbia St
Springfield, OH
45503
937-325-7091

Writer sending case to 82S for further review. Please allow 2-5 business days for an investigation to be completed. Customer will be notified of decision.

02.06.12

>> case is being forwarded to Chrysler Legal (CCRG) (2-5 days contact)

VEHICLE LOCATED AT:

BILL MARINE CHRY-DODGE-JEEP

1182 W MAIN STREET

WILMINGTON OH 45177

937-382-3858

Per OGC Matrix, reassigned to 82T. MG17

Mary Newman from Westfield Insurance 513-985-9080 at extension 4432430

Reference customers name, [REDACTED]. She called and stated she

would like it if Chrysler's investigator could get together with their O

and C expert- Efi Global contact name is Rick Price- 859-408-5747, to

look at and inspect the vehicle at the same time. Agent stated the case

would be documented. She would like either the CM to contact her or the

expert on this case.

2/8/12 ASSIGNED TO RLG92. PAG

CAIR NUMBER 21850450 REQUEST EAA INSPECTION 02-08-2012 13:22

CAIR NUMBER 21850450 E-MAIL SENT TO EAA 02-08-2012 13:22

Customer called in stating he has not heard back from Chrysler yet about

his case. Customer states he would like a call back as soon as possible

about seeing his vehicle. Customer states his cell phone is [REDACTED].

CCRG Open Date: 02/06/2012 15:28:45

Letter Sent: Acknowledgement 02/09/2012 09:56:03

PHOTOGRAPHIC IMAGES POSTED TO THIS CAIR ON 02/14/12 AT 08:43:48 21850450

PLEASE REFER TO CAIR 21887915 FOR ADDITIONAL INFORMATION

Letter Sent: Offer 02/15/2012

[REDACTED] called in stating that he has not heard anything back

from his case manager. Customer states that this has not been settled

yet. Writer advised letter has been sent out, customer would need to wait

for the letter to arrive in the mail.

Briefly summarize why the customer is contacting Chrysler:

Customer is calling today to find out the result on this case for

investigation.

Agent advised the customer that he needs to wait for the letter to come

to his residence for a response to the investigation.

Customer understands and has no further questions or concerns.

Briefly summarize what the customer is expecting:

Customer Assistance Inquiry Record (CAIR)#

21902599

VIN	1C4RJECG5	CC [REDACTED]	Open Date	02/20/2012	Built Date	11/10/2011
Model Year	2012	Body	WKTS74	JEEP GRAND CHEROKEE OVERLAND 4X2 SPORT UTILITY		
In Service Dt	12/09/2011	Mileage	2,300	Dealer Zone	71	LOS ANGELES
Plant	C	JEFFERSON NORTH ASSEMBLY PLANT		Market	U	US
Color	PW1	STONE WHITE CLEAR COAT				
Engine	ERB	3.6L V6 24V VVT ENGINE				
Transmission	DGJ	5-SPEED AUTO W5A580 TRANSMISSION				
Dealer	24097	TUTTLE-CLICK CHRYSLER JEEP DODGE				
Dealer Address	40 AUTO CENTER DRIVE					
Dealer City	IRVINE	Dealer State	CA	Dealer Zip	92618	
Owner	[REDACTED]				Contact Type	TELEPHONE
Address	[REDACTED]				Home Phone	[REDACTED]
	COTO DE CAZA CA [REDACTED]				Country	UNITED STATES

Corporate - Lemon Law - Default - Default - Default	Re-occurring electrical problems
Product - Electrical - Body Wiring - Intermittent or Inoperative - Default	Referred to pursue Lemon Law
Dealer - By-Pass - Default - Default - Default	

Lemon Law:

Briefly summarize why the customer is contacting Chrysler: Customer states they have had re-occurring electrical problems since November. (ISD 12/09/2011)

Briefly summarize what the customer is expecting: Customer states they have been referred by Dealership to pursue Lemon Law.

Customer informed a call back is required and will take place within one business day.

Preferred Morning/Midday call back number is [REDACTED]

Preferred Afternoon/Evening call back number is [REDACTED]

Customer email address for case updates: [REDACTED]

Who has possession of the vehicle? TUTTLE-CLICK CHRYSLER JEEP

Is this a request for Lemon Law, buy-back or replacement? Customer states that they want to pursue Lemon Law.

Reassigned to 88L

***** QUALIFIER TEAM *****

CONTACT UPDATE - 1st Contact attempt, phone number dialed,

[REDACTED] Left message stating we are sending case out for further review.

[REDACTED] No answer no voice mail.

Owner is seeking relief under the California state lemon law.

1. What does the customer allege is wrong with the vehicle? Electrical.

2. Was the vehicle purchased new or used? New.

3. If used, what number owner is the customer and what was the mileage?

4. Is customer claiming # of repair attempts or # of days out of service?

Unsure.

5. Does the condition described by the customer still exist? Yes.

The only thing the customer has been told is their file will be reviewed and/or handled by the local Business Center and Dealer, and if

the condition still exists, to take their vehicle to the dealer
regardless
of this request. Reassigned to the West Business Center (TMT).
022212 reassigned to am slw5 to review and respond to owners request for
lemon law relief tmt
022912..dm slw5 spoke to customer and this is third time for all
dashlights, headlamp, fuse, hazard do not operate and with 2339 miles
vehicle has been down 20 days. customer loves vehicle but feels this last
repair almost started a fire in the headliner and has lost all confidence
in the vehicle. dm agrees to replace the vehicle and no mileage fee since
vehicle had 332 miles at first repair. dm to complete isg template..slw5

Customer Assistance Inquiry Record (CAIR)# 22011713

VIN	1C4RJFAG9	CC [REDACTED]	Open Date	03/19/2012	Built Date	01/04/2012
Model Year	2012	Body	WKJH74	JEEP GRAND CHEROKEE LAREDO 4X4 SPORT UTILITY		
In Service Dt	02/16/2012	Mileage	1,000	Dealer Zone	74	DENVER
Plant	C	JEFFERSON NORTH ASSEMBLY PLANT	Market	U	US	
Color	PXR	BRILLIANT BLACK CRYSTAL PEARL COAT				
Engine	ERB	3.6L V6 24V VVT ENGINE				
Transmission	DGJ	5-SPEED AUTO W5A580 TRANSMISSION				

Dealer	68280	WOODHOUSE CHRYSLER JEEP DODGE
---------------	-------	-------------------------------

Dealer Address	2171 SOUTH HWY 30					
-----------------------	-------------------	--	--	--	--	--

Dealer City	BLAIR	Dealer State	NE	Dealer Zip	68008	
--------------------	-------	---------------------	----	-------------------	-------	--

Owner	[REDACTED]	Contact Type	TELEPHONE
--------------	------------	---------------------	-----------

Address	[REDACTED]	Home Phone	(319) 743-1187
----------------	------------	-------------------	----------------

[REDACTED]	CEDAR RAPIDS IA [REDACTED]	Country	UNITED STATES
------------	----------------------------	----------------	---------------

Product - Electrical - Power Windows - Steam or Smoke - Unknown	Customer states seeing smoke and flames from the sunroof area.
Dealer - By-Pass - Default - Default - Default	
Product - Unknown - Unknown - Fire - Unknown	

Area Manager Dan Marsh contacted by Service Manager Matt Eschliman from selling dealer 68280. Matt was handed a note with the customer information and concern. SM called customer, customer stated he pulled the vehicle in his driveway, and noticed some smoke coming from around the headliner area. He took his daughter out of the car and investigated the smoke a little more and noticed open flames. He was able to put out the fire using a fire extinguisher. According to the customer, no one was hurt or killed, no accident and no collateral damage. The number listed above is a home phone number for the customer. The preferred method of contact is the customer s cell phone, [REDACTED]. AM reassigning to JSS15 for handling.

VEHICLE IS LOCATED AT:
 9224 DEER VALLEY DR
 CEDAR RAPIDS IA 52411-8134
 319 743 1187

Per OGC Matrix, reassigned to 82T.
 PHOTOGRAPHIC IMAGES POSTED TO THIS CAIR ON 03/19/12 AT 14:31:58 22011713
 3/19/12 ASSIGNED TO RLG92. PAG
 CAIR NUMBER 22011713 REQUEST EAA INSPECTION 03-19-2012 15:06
 CAIR NUMBER 22011713 E-MAIL SENT TO EAA 03-19-2012 15:06
 CCRG Open Date: 03/19/2012 14:21:38
 Letter Sent: Acknowledgement 03/20/2012 09:44:05
 PHOTOGRAPHIC IMAGES POSTED TO THIS CAIR ON 03/23/12 AT 14:34:11 22011713

Customer Assistance Inquiry Record (CAIR)#

22027135

VIN	1J4RR5GT1	BC [REDACTED]	Open Date	03/21/2012	Built Date	05/27/2011
Model Year	2011	Body	WKJP74	JEEP GRAND CHEROKEE LIMITED 4X4 SPORT UTILITY		
In Service Dt	02/09/2012	Mileage	7,363	Dealer Zone	42	DETROIT
Plant	C	JEFFERSON NORTH ASSEMBLY PLANT		Market	U	US
Color	PDM	MINERAL GRAY MET. CLEAR COAT				
Engine	EZH	5.7L V8 MDS VVT ENGINE				
Transmission	DGQ	5-SPD AUTOMATIC 545RFE TRANSMISSION				

Owner	[REDACTED]	Contact Type	TELEPHONE
Address	[REDACTED]	Home Phone	(812) 525-7870
	TRAFALGAR IN [REDACTED]	Country	UNITED STATES

Corporate - Property Damage - Default - Default - Default	
Dealer - By-Pass - Default - Default - Default	
Product - Electrical - Unknown - Other - Default	
Product - Unknown - Unknown - Fire - Interior	
Product - Unknown - Unknown - Fire - Unknown	

3/21 [REDACTED] bought a new 2011 Jeep Grand Cherokee from Eastgate Chrysler on 2/9/2012. The vehicle was towed in today with the passenger visor mirror melted and the headliner burned. The melted plastic dripped onto the front right seat causing damage to that area as well

3/21 GM from Bob Poynter called with this information, vehicle caught on fire while driving. Customer has 2 young children and she does not want vehicle anymore stating this was terrifying and will not trust vehicle with keeping her family from harm. File to be open to Special Investigations for handling. mwp

03.22.12

>> case is being forwarded to Chrysler Legal (CCRG) (2-5 days contact)

VEHICLE LOCATED AT:

BOB POYNTER CHRYSLER DODGE JEEP,
3020 N NATIONAL RD
COLUMBUS IN 47201
812-372-2575

Per OGC Matrix, reassigned to 82T. MG17

3/22/12 ASSIGNED TO RLG92. PAG

CAIR NUMBER 22027135 REQUEST DEKRA INSPECTION 03-22-2012 13:12

CAIR NUMBER 22027135 E-MAIL SENT TO DEKRA 03-22-2012 13:12

CCRG Open Date: 03/22/2012 10:39:16

Letter Sent: Acknowledgement 03/23/2012 10:54:57

PHOTOGRAPHIC IMAGES POSTED TO THIS CAIR ON 03/29/12 AT 15:23:53 22027135

Customer Assistance Inquiry Record (CAIR)#**22046945**

VIN	1C4RJFCT8	CC [REDACTED]	Open Date	03/27/2012	Built Date	12/10/2011
Model Year	2012	Body	WKJS74	JEEP GRAND CHEROKEE OVERLAND 4X4 SPORT UTILITY		
In Service Dt	02/24/2012	Mileage	1,618	Dealer Zone	32	NEW YORK
Plant	C	JEFFERSON NORTH ASSEMBLY PLANT	Market	U	US	
Color	PXR	BRILLIANT BLACK CRYSTAL PEARL COAT				
Engine	EZH	5.7L V8 MDS VVT ENGINE				
Transmission	DG1	6-SPD AUTOMATIC 65RFE TRANSMISSION				
Dealer	66325	BAYSIDE CHRYSLER JEEP DODGE				
Dealer Address	21219 NORTHERN BLVD					
Dealer City	BAYSIDE	Dealer State	NY	Dealer Zip	11361	
Owner	[REDACTED]			Contact Type	TELEPHONE	
Address	[REDACTED]			Home Phone	[REDACTED]	
	SUNNYSIDE NY [REDACTED]			Country	UNITED STATES	

Product - Electrical - Body Wiring - Other - Default	Fire Claim
Product - Unknown - Unknown - Fire - Interior	Fire Claim
Corporate - Property Damage - Default - Default - Default	
Product - Unknown - Unknown - Fire - Unknown	

Customer claims that an electrical fire resulted from a defective passenger overhead vanity lamp
Suggest Special Investigations Review

VEHICLE IS LOCATED AT:
BAYSIDE CHRYSLER JEEP DODGE
21219 NORTHERN BLVD
BAYSIDE , NY 113613341
718 428-8777
718 229-8700

Per OGC Matrix, reassigned to 82T.
3/27/12 ASSIGNED TO RLG92. PAG
CAIR NUMBER 22046945 REQUEST DEKRA INSPECTION 03-27-2012 13:12
CAIR NUMBER 22046945 E-MAIL SENT TO DEKRA 03-27-2012 13:12
CCRG Open Date: 03/27/2012 11:43:02
Letter Sent: Acknowledgement 03/28/2012 11:31:47
PHOTOGRAPHIC IMAGES POSTED TO THIS CAIR ON 03/30/12 AT 16:41:58 22046945

Customer Assistance Inquiry Record (CAIR)# 22302459

VIN	1C4RJFCT6	CC [REDACTED]	Open Date	06/07/2012	Built Date	03/29/2012
Model Year	2012	Body	WKJS74	JEEP GRAND CHEROKEE OVERLAND 4X4 SPORT UTILITY		
In Service Dt	08/11/2012	Mileage	1,679	Dealer Zone	63	DALLAS
Plant	C	JEFFERSON NORTH ASSEMBLY PLANT	Market	U	US	
Color	PS2	BRIGHT SILVER METALLIC CLEAR COAT				
Engine	EZH	5.7L V8 MDS VVT ENGINE				
Transmission	DG1	6-SPD AUTOMATIC 65RFE TRANSMISSION				
Dealer	43290	HUFFINES CHRYSLER JEEP DODGE LEWIS	VILLE			
Dealer Address	1024 SOUTH STEMMONS FRWY					
Dealer City	LEWISVILLE	Dealer State	TX	Dealer Zip	75067	
Owner	[REDACTED]				Contact Type	FAX
Address	[REDACTED]				Home Phone	
	LEWISVILLE TX	[REDACTED]	Country	UNITED STATES		

Corporate - Property Damage - Default - Default - Default	
Dealer - By-Pass - Default - Default - Default	
Product - Body / Trim / Paint Finish - Interior Ornamentation/Mirrors - Other - Sun Visors/Vanity	
Product - Electrical - Unknown - Other - Default	
Product - Unknown - Unknown - Fire - Interior	
Product - Unknown - Unknown - Fire - Unknown	

dealer demo - wires to lighted visor vanity mirror melted under headliner
 This is a 1,600 mile Grand Cherokee in Demo service came in with complaint of smoke coming from the headliner area. Dealer removed headliner to find wiring burned, screw from sun visor had been screwed into wiring harness attached to the headliner. Photos show insulation and wiring burned. Note that dealer was surprised to find that there is no fuse on this circuit, it goes directly into the TIPM.

06.08.12

VEHICLE LOCATED AT:
 HUFFINES CHRYSLER JEEP DODGE LEWIS
 1024 S STEMMONS FWY
 LEWISVILLE TX 75067
 972-434-2288

PLEASE CONTACT AND ARRANGE INSPECTION TO DETERMINE CAUSE OF LOSS.
 PLEASE PROVIDE FULL FIRE REPORT, PHOTOS, POLICE/FIRE DEPT REPORT (if available) AND ANY OTHER PERTINENT INFORMATION. THANKS, MG17
 CAIR NUMBER 22302459 REQUEST EAA INSPECTION 06-08-2012 11:25
 CAIR NUMBER 22302459 E-MAIL SENT TO EAA 06-08-2012 11:25

> Called and left VMM for [REDACTED] in dlr - do not repair - we are going to inspect - and asked him to call back with an est to repair if he has one
 >> Ron Leach Please keep me in the loop on this maggie

> Est Parts 1358.25 Labor 192.57 Total 1550.82

PHOTOGRAPHIC IMAGES POSTED TO THIS CAIR ON 06/11/12 AT 18:10:48 22302459

POSTMARK DATE: 061112; DATE RECEIVED: 061212

06.18.12

Reviewed EAA report and photos
dlr Demo - sun visor fire - we inspected and approved repairs
emailed Ron Leach
NOTE> Attached photo log & dlr est

Customer Assistance Inquiry Record (CAIR)#**22384829**

VIN	1D4RE4GG8	BC [REDACTED]	Open Date	07/03/2012	Built Date	01/22/2011
Model Year	2011	Body	WDEH75	DODGE DURANGO CREW AWD SPORT UTILITY 4-DR		
In Service Dt	04/23/2011	Mileage	16,000	Dealer Zone	74	DENVER
Plant	C	JEFFERSON NORTH ASSEMBLY PLANT	Market	U	US	
Color	PRH	INFERNO RED CRYSTAL PEARL COAT				
Engine	ERB	3.6L V6 24V VVT ENGINE				
Transmission	DGJ	5-SPEED AUTO W5A580 TRANSMISSION				

Dealer	63208	VOS MOTOR SALES INC
---------------	-------	---------------------

Dealer Address	1460 N MAIN AVE					
-----------------------	-----------------	--	--	--	--	--

Dealer City	SIOUX CENTER	Dealer State	IA	Dealer Zip	51250	
--------------------	--------------	---------------------	----	-------------------	-------	--

Owner	[REDACTED]	Contact Type	TELEPHONE
--------------	------------	---------------------	-----------

Address	[REDACTED]	Home Phone	[REDACTED]
----------------	------------	-------------------	------------

SIOUX CENTER IA [REDACTED]	Country	UNITED STATES
----------------------------	----------------	---------------

Corporate - Property Damage - Default - Default - Default	
Product - Unknown - Unknown - Fire - Interior	
Product - Unknown - Unknown - Fire - Unknown	

Referral from BC.

Vos Motors had a 2011 Durango with about 16K miles catch fire yesterday.

The dealer believes it started in the headliner and ended up melting the front passenger seat.

VEHICLE IS LOCATED AT:

VOS MOTOR SALES INC CJDTR

1460 N MAIN AVE SIOUX CENTER IA 51250 712-722-3396

Per OGC Matrix, reassigned to 82T.

7/3/12 ASSIGNED TO RLG92. PAG

CAIR NUMBER 22384829 REQUEST EAA INSPECTION 07-03-2012 11:29

CAIR NUMBER 22384829 E-MAIL SENT TO EAA 07-03-2012 11:29

CCRG Open Date: 07/03/2012 10:34:55

Letter Sent: Acknowledgement 07/05/2012 08:31:30

PHOTOGRAPHIC IMAGES POSTED TO THIS CAIR ON 07/06/12 AT 15:09:08 22384829

Customer Assistance Inquiry Record (CAIR)#**22397922**

VIN	1C4RJFAGX	CO [REDACTED]	Open Date	07/06/2012	Built Date	05/25/2012
Model Year	2012	Body	WKJH74	JEEP GRAND CHEROKEE LAREDO 4X4 SPORT UTILITY		
In Service Dt	06/16/2012	Mileage	600	Dealer Zone	32	NEW YORK
Plant	C	JEFFERSON NORTH ASSEMBLY PLANT		Market	U	US
Color	PW1	STONE WHITE CLEAR COAT				
Engine	ERB	3.6L V6 24V VVT ENGINE				
Transmission	DGJ	5-SPEED AUTO W5A580 TRANSMISSION				

Dealer	44740	DODGE OF PARAMUS INC				
---------------	-------	----------------------	--	--	--	--

Dealer Address	315 ROUTE 4 WEST					
-----------------------	------------------	--	--	--	--	--

Dealer City	PARAMUS	Dealer State	NJ	Dealer Zip	07652	
--------------------	---------	---------------------	----	-------------------	-------	--

Owner	[REDACTED]	Contact Type	TELEPHONE
--------------	------------	---------------------	-----------

Address	[REDACTED]	Home Phone	[REDACTED]
----------------	------------	-------------------	------------

NEW YORK NY [REDACTED]	Country	UNITED STATES
------------------------	----------------	---------------

Product - Electrical - Unknown - Steam or Smoke - Default	Smoke inside vehicle
Corporate - Complaint Contact - Default - Default - Default	Smoke inside vehicle family doesn't feel safe driving it
Corporate - Property Damage - Default - Default - Default	
Dealer - By-Pass - Default - Default - Default	

Briefly summarize why the customer is contacting Chrysler: Customer states the day after he purchased the vehicle the interior lights stopped working and he had to bring it back to the dealership. Customer states the dealership replaced the fuse and he went home. Customer states he brought his vehicle to the dealership because it was smoking inside the vehicle. Customer states the dealership advised him the vehicle overheated and the customer states he doesn't feel safe in the vehicle with his family. Agent advised customer that his concerns would be escalated to a CM for further assistance.

Briefly summarize what the customer is expecting: Customer seeking assistance with vehicle repaired or possibly to have the vehicle replaced if the dealership can't repair it properly.

Customer advised a call back is required and will take place within one business day by COB their time
 Preferred Morning/Midday call back number is [REDACTED]
 Preferred Afternoon/Evening call back number is [REDACTED]
 Customer email address for case updates: [REDACTED]
 Who has possession of the vehicle? Dealer
 Has the vehicle been diagnosed by a CDJ dealer? Yes
 If a CDJ dealer has diagnosed, what is the dealer name or code? CHRYSLER JEEP DODGE OF PARAMUS
 Reassigned to 88F
 Status update provided via email to the following email address:
 [REDACTED]

My name is Tammy and I have been assigned as your Case Manager. Here is some information that will be helpful for you to have:

Chrysler Case Management telephone Number: 800-763-8422 my direct extension: 66380

Your Case # 22397922

My work hours: 10:30 AM till 7 PM Eastern Standard Time. Monday-Friday.

End of Status Update

CAIR has been escalated to the I2R team for special handling.

*****Kim Anderson with the I2R Customer Resolution Team is now responsible for this CAIR. If the customer should call, please request them to contact Kim Anderson at 888-542-7239, extension 440. Thank you.*****

7/10/2012 KA286

Called owner and left voice mail to call about vehicle.

>Spoke with Chris SA at Paramus and she said vehicle was picked up today- they were unable to duplicate the smoke- NTF.

If the customer contacts Chrysler, please refer them to their I2R Case Manager Kim Anderson at 888-542-7239 ext 440.

7/11/2012 KA286

7/11/2012 8:41:48 AM: User Comment by Kim Anderson: Initial call with owner who is very frustrated with Paramus. He said originally his dash lights went out 2 days after he purchased vehicle. They replaced a fuse (warranty system shows steering column module) and gave back to him. About a week later they inside of vehicle began to fill with smoke. Said it was coming from the roof and visor area; visor actually melted a little. He took it to Paramus and they called his wife yesterday and said it is repaired and ready to be picked up. He called them back and asked what was wrong and what had they done. They told him 'well, really we couldn't find anything wrong so we didn't do anything'. He has not and does not want to pick it up; he is in a loaner vehicle. I explained to him what we do and made sure he has my phone number. Told him I wanted to speak to Paramus and do some research before he picks up (don't think he will). Said he just wants out of vehicle- wants another one just like this one. But is worried and does not want his family and newborn back in that vehicle. Said he does not trust Paramus or any of the things they said they did- now doesn't believe they even replaced a fuse the first time it was in repair. Told him I would get back with him and he thanked me for calling and getting involved.

>Called for Steven Brandt Service Manager at Paramus but he was not available. Left message with Jenna for him to call me back about this vehicle.

If the customer contacts Chrysler, please refer them to their I2R Case Manager Kim Anderson at 888-542-7239 ext 440.

7/11/2012 KA286

Spoke with Steve Service Manager at Paramus and he said originally they didn't find any issue with over heating under the hood. But said later when the husband called, they figured out he was referring to smoke/fire inside the cab, not under the hood. They investigated and did find a screw used to affix the visor was installed through a wire - at the factory. This caused it to short and smoke. They have ordered a new visor which should arrive tomorrow and will be repairing the wiring. He said after that it will be up to me and Chrysler cause he doesn't think they will want vehicle. I explained to him that is probably because they were originally told NTF, so they were upset. Now we know there was something and what it was, so owner may be more receptive, we will see.

If the customer contacts Chrysler, please refer them to their I2R Case Manager Kim Anderson at 888-542-7239 ext 440.

7/12/2012 KA286

Spoke with DM-PPF and updated him about this owner and Paramus. Explained owner upset, there was some communication between owner and dealer. They thought fire and smoke was from under hood- that is where they looked. Turned out smoke was inside cab, coming from wires overhead. Agreed I would present to owner that they misunderstood, did find issue and melted visor, was a screw put through wiring.

>Spoke with owner and asked if he had heard from Paramus yet and he said no. Told him that the dealership originally thought smoke he reported was from under the hood of vehicle. I explained to them that once he redirected them to inside of the cab, they did find the melted visor. And

discovered that when visor was mounted, a screw was put in through the wiring; causing the short and smoke. Told him they ordered and should receive a new visor today and will also be rewiring. He is still upset. Said he doesn't care what it was, is not going to put his family and 9 month baby back in the vehicle. Went on to say, he didn't pay for a rewired vehicle, he paid for a brand new vehicle and that is what he wants. Also said he wants to know how many other Jeeps have had this issue; asked me to get him a report of some kind. Explained to him, will not be able to provide that-proprietary info. Told him I could update the DM but also want to wait and see how extensive the wiring issue is with Paramus.

If the customer contacts Chrysler, please refer them to their I2R Case Manager Kim Anderson at 888-542-7239 ext 440.

7/13/2012 KA286

Spoke with Steven Service Manager at Paramus and he says they have completed repairs. Also have called the owner and let him know it is ready to pick up.

Follow up with owner 7/16.

If the customer contacts Chrysler, please refer them to their I2R Case Manager Kim Anderson at 888-542-7239 ext 440.

[REDACTED] is requesting to speak with Case Manager KA286. Customer transferred to the phone number and extension listed above, lines 112-113.

Customer refuses to get the CM's phone number as she was in a hurry.

[REDACTED] requesting to speak with Case Manager KA286. CM not available. Caller is at the dealership looking for a resolution to issue. Caller states it is an urgent matter and would like to be contacted back at 201-214-9217.

7/16/2012 KA286

Received a voice mail from owner stating she is at the dealership and they are telling her she has to get approval from me to get a new vehicle.

>Confirmed with DM, we are NOT replacing vehicle and he said absolutely not.

>Spoke with owner and explained her vehicle is ready- which she knew, was already at dealership. She said she had spoken to Mike in sales and he told her there was nothing they could do; that Chrysler would have to give the authorization for her to get a new vehicle. I explained to her the process and that her vehicle is now repaired so there is no offer to replace. Told her I did speak with DM who makes those decisions and we have repaired under warranty. She went on to say how dangerous the vehicle is, safety issue, baby had to go to Dr after the plastic visor burned, how she had to pay for rental, toll charges to and from dealership. I offered her a monthly reimbursement. She is in a lease so could not offer her service contract. Told her to send me any rental costs she may have incurred and I could reimburse her. Also offered her a 2nd reimbursement and she accepted. She will send all her docs in for us to look over.

If the customer contacts Chrysler, please refer them to their I2R Case Manager Kim Anderson at 888-542-7239 ext 440.

7/20/2012 KA286

Spoke with owner and she will gather her docs and fax in; said will be today or tomorrow.

If the customer contacts Chrysler, please refer them to their I2R Case Manager Kim Anderson at 888-542-7239 ext 440.

7/27/2012 KA286

received lease docs, waiting on rental docs

Spoke with owner and she is getting a copy of rental charges and will send those in.

If the customer contacts Chrysler, please refer them to their I2R Case Manager Kim Anderson at 888-542-7239 ext 440.

7/30/12 Emailed tjb16 requesting to process the customer's payment reimbursement in the amount of \$824.28 (two payments and rental). Follow up regarding reimbursement on 8/1/12. CM

7/30/2012 2:01:32 PM: User Comment by Kim Anderson: Received rental docs from owner which show they were charged \$122.96 but refunded \$58.68 of

that back. Verified this with Mike at Enterprise so rental reimbursement is for \$64.28

Check approved.

***** Below Customer Contacted for Documentation Request *****

tjb16@chrysler.com on 2012-08-01 @ 17:36

***** Customer Document Received *****

Check received and sent to customer through US Mail.

8/2/12 Received email from tjb16 confirming customer's payment reimbursement in the amount of \$824.28 (two payments and rental) has been issued and mailed to the customer. CM

8/2/2012 KA286

Called owner and left voice mail checking on vehicle and that we processed and mailed her reimbursement today. To call if has any questions or needs any assistance.

If the customer contacts Chrysler, please refer them to their I2R Case Manager Kim Anderson at 888-542-7239 ext 440.

Vehicle repaired, gave 2 month's reimbursement of \$380.00 x 2 = \$760.00 plus rental costs accrued \$64.28 for a total of \$ 824.28--payment has been mailed 8/2/12. Owner happy with resolution.

If the customer contacts Chrysler, please refer them to their I2R Case Manager Kim Anderson at 888-542-7239 ext 440.

9/6/2012 KA286

Spoke with owner and she is stating that we did not fully reimburse her for her expenses. Owner is stating that she had \$49.00 in toll charges and \$30.00 in gas to travel from New York to New Jersey, back and forth to dealership. Advised that her vehicle was down for a total of 5 days and we reimbursed her a whole month for that inconvenience and new vehicle needing repair. The additional month reimbursement was for her various costs involved with repairing the vehicle and because she would not have any documentation for tolls; plus the 64.28 rental cost. She said she understood me to say that I would reimburse her those 2 months PLUS other various costs. Went on to say that she is a professional, used to work for Goldman and Sachs and knows exactly what I said. I apologized to her for the miscommunication but my intention was to reimburse her for those costs in the second month's reimbursement- to group it all together. She stated she expects me to stand by my word. I asked her exactly how much is short- what amount she is expecting. She went over the toll charges and gas used and said \$79.00. I told her I would have to check into this and asked her again to make sure this is the correct amount; don't want to request this and it not be correct. She said let me check, and went over her totals and said, 'looks like you did reimburse me for the rental so it is just the \$79.00. Made sure to clarify with her that she feels she was shorted \$79.00 and she agreed. Then stated, 'you know it may not be a lot of money to you but considering my family's new vehicle caught fire and my newborn was ill from the smoke- you should do what you said you would'. Told her I would check into it and get back to her.

If the customer contacts Chrysler, please refer them to their I2R Case Manager Kim Anderson at 888-542-7239 ext 440.

9/12/2012 KA286

Spoke with owner and informed her we would need copies of receipts for her toll tag and fuel reimbursement. If she could provide those, then we can reimburse her that additional \$79.00. She said she would see what she could do and call me back.

If the customer contacts Chrysler, please refer them to their I2R Case Manager Kim Anderson at 888-542-7239 ext 440.

Customer Assistance Inquiry Record (CAIR)#**22428367**

VIN	1C4RJFAG4C [REDACTED]	Open Date	07/16/2012	Built Date	02/06/2012
Model Year	2012	Body	WKJH74	JEEP GRAND CHEROKEE LAREDO 4X4 SPORT UTILITY	
In Service Dt	06/30/2012	Mileage	1,132	Dealer Zone	74 DENVER
Plant	C	JEFFERSON NORTH ASSEMBLY PLANT	Market	U	US
Color	PW1	STONE WHITE CLEAR COAT			
Engine	ERB	3.6L V6 24V VVT ENGINE			
Transmission	DGJ	5-SPEED AUTO W5A580 TRANSMISSION			

Dealer	68116	PARKS INC
---------------	-------	-----------

Dealer Address	11987 SW US HWY 54				
-----------------------	--------------------	--	--	--	--

Dealer City	AUGUSTA	Dealer State	KS	Dealer Zip	67010
--------------------	---------	---------------------	----	-------------------	-------

Owner	[REDACTED]	Contact Type	TELEPHONE
--------------	------------	---------------------	-----------

Address	[REDACTED]	Home Phone	[REDACTED]
----------------	------------	-------------------	------------

AUGUSTA KS [REDACTED]	Country	UNITED STATES
-----------------------	----------------	---------------

Product - Unknown - Unknown - Fire - Interior	Interior shows signs of thermal event in headliner.
Corporate - Property Damage - Default - Default - Default	

AM received email from Service Manager notifying AM that vehicle had a thermal event in the headliner near the RF visor. Plastic melted and caused damage to interior seat, glove box and also interior door panel. SM did state that customer was driving the vehicle when this event occurred. SM also noted that vehicle had headliner removed at one point to correct hail damage. AM will send to SI for further investigation. Dealer will not proceed until notification is given.

PARKS INC CJDTR
11987 SW US HWY 54 AUGUSTA KS 67010 316-775-6366

Per OGC Matrix, reassigned to 82T.
7/17/12 ASSIGNED TO RLG92. PAG
CAIR NUMBER 22428367 REQUEST EAA INSPECTION 07-17-2012 10:36
CAIR NUMBER 22428367 E-MAIL SENT TO EAA 07-17-2012 10:36
CCRG Open Date: 07/17/2012 09:21:55
Letter Sent: Acknowledgement 07/18/2012 10:18:08
PHOTOGRAPHIC IMAGES POSTED TO THIS CAIR ON 07/20/12 AT 16:02:49 22428367
Letter Sent: Denial 07/23/2012

Customer Assistance Inquiry Record (CAIR)#

22460026

VIN	1C4RJFAG0C		Open Date	07/25/2012	Built Date	03/18/2012
Model Year	2012	Body	WKJH74	JEEP GRAND CHEROKEE LAREDO 4X4 SPORT UTILITY		
In Service Dt	04/30/2012	Mileage	5,000	Dealer Zone	32	NEW YORK
Plant	C	JEFFERSON NORTH ASSEMBLY PLANT	Market	U	US	
Color	PXR	BRILLIANT BLACK CRYSTAL PEARL COAT				
Engine	ERB	3.6L V6 24V VVT ENGINE				
Transmission	DGJ	5-SPEED AUTO W5A580 TRANSMISSION				
Dealer	23153	WESTBURY JEEP CHRYSLER DODGE, INC.				
Dealer Address	928 JERICHO TPKE					
Dealer City	WESTBURY	Dealer State	NY	Dealer Zip	11590	
Owner					Contact Type	TELEPHONE
Address					Home Phone	
	ROSLYN HEIGHTS NY				Country	UNITED STATES

Product - Frame - Unknown - Defective - Default	Sunroof making sounds.
Dealer - By-Pass - Default - Default - Default	

Briefly summarize why the customer is contacting Chrysler: Customer stated that he took the vehicle to WESTBURY JEEP CHRYSLER DODGE, INC Dealer Code: 23153 and it was making noise coming from the roof. Customer was informed by SA Dave the vehicle has structural issues and they need to take the roof apart and may have to do some welding to repair the structure. Customer is under the impression this may be a safety issue. Writer contacted SA Dave at Dealer Code: 23153 he stated he would not have a definite answer until he gets to the Jeep later this afternoon 7/25/12.

Briefly summarize what the customer is expecting: Customer would like the vehicle replaced if he can not be assured that this is not a safety concern.

Customer advised a call back is required and will take place

within one business day by COB their time

Preferred Morning/Midday call back number is

Preferred Afternoon/Evening call back number is

Customer email address for case updates:

Who has possession of the vehicle? (Dealer)

Has the vehicle been diagnosed by a CDJ dealer? (Yes)

If a CDJ dealer has diagnosed, what is the dealer name or code? WESTBURY

JEEP CHRYSLER DODGE, INC Code: 23153

Reassigned to 88F

***** CASE MANAGER TEAM - District Q *****

Customer is the original owner. There are no other vehicles in the household.

The vehicle is in Warranty.

There are no restrictions or recalls.

There are no service contracts.

CONTACT UPDATE - 1st Contact attempt, phone number dialed,

Writer left message on VM with contact information and hours of business.
Status update provided via email to the following email address:

[REDACTED]. My name is Steve from Chrysler Customer Care. I have been assigned as your Case Manager. Here is some information that may help. Your case number is 22460026.

My phone number is 800-763-8422 Ext. 66353.

My hours are from 9:00AM to 5:30 PM EST. Monday through Friday.

End of Status Update

Customer called writer. Customer upset at dealer. customer states that the vehicle has been at the dealer for a week and nothing has been done to the vehicle. Customer describes the vehicle as a safety issue. The customer feels that if the dealer starts to take the vehicle apart and putting it back together they could do more harm. Customer advised writer that if he cannot be assured that the vehicle is safe that he would trade the vehicle in. Writer advised customer that this would be through the dealer. Writer advised that writer would contact dealer and then follow up with the customer on Monday.

Dealer (SD) Tim calls to speak with their Case Manager.

Writer warm transferred the call to the CM at 66353.

Dealer called writer. Dealer states that the vehicle has a loose weld that causes the noise to occur when the vehicle is flexed. service Manager Tim states that the vehicle is being worked on at this time.

Dealer is unable to give an exact time the vehicle will be repaired.

CAIR has been escalated to the I2R team for special handling.

*** Harlan Cooper with the I2R Customer Resolution Team is now responsible for this CAIR. If the customer should call, please request them to contact Harlan Cooper at 888-542-7239, extension 536. Thank you.

7/27/12 Left voice mail for customer to call back regarding his vehicle repair concerns. HC616

*** If the customer should call, please request them to contact Harlan Cooper at 888-542-7239, extension 536. Thank you. ***

7/30/12 Customer left voice mail asking to call back on 7/27/12.

<< Left voice mail apologizing for missing his call. Left voice mail for customer to call back regarding his vehicle repair concerns. HC616

*** If the customer should call, please request them to contact Harlan Cooper at 888-542-7239, extension 536. Thank you. ***

Case reassigned to HC616

7/30/12 Spoke to customer to complete the initial call. Customer advised he has only owned his vehicle for 3 months and it has been in for service a total of two and a half weeks. Customer is frustrated and tired with dealing with Westbury Jeep Chrysler Dodge (23153). The customer feels they are guessing at the problem and not finding the solution. Customer advised the dealer acknowledges the problem, they just cannot fix it. Customer advised he was told by the dealer to contact Chrysler with his issues. Customer advised this is a structural issue and he is deeply concerned about the safety of his wife and child. Customer advised he is paying for a vehicle he cannot drive and he is upset with a car that has so many problems in only 3 months of service. Customer wants a replacement vehicle. Apologized to customer for the inconvenience, as I can certainly understand his frustration. Advised customer that his case has been forwarded to me for Special Handling to assist with vehicle repair per the Terms of the Warranty, including Escalated Technical assistance, parts expediting and Rental authorization if necessary. Advised customer that I would like to review his case with the Dealer. Advised customer I will call him back on Wednesday 8/01 to follow up with an update. Customer thanked me. HC616

7/31/12 Spoke to the customer about his vehicle. Customer advised the dealer called him this morning saying the vehicle was repaired and ready for pick up. Customer advised he is a little unsure about the repair but plans to pick the vehicle up today. Customer advised he would like a better understanding on exactly what they did to his vehicle. Advised customer I will contact the dealer and get a better idea on the vehicle repair. Customer thanked me. HC616

*** If the customer should call, please request them to contact Harlan

Cooper at 888-542-7239, extension 536. Thank you. ***

8/07/12 Spoke to Service Advisor David at Westbury CDJ (23153) about the customer's vehicle repair. David and I went over the last repair order for the customer. David advised the customer had a complaint about noise and they were able to locate the problem. The rear sunroof glass was replaced and fixed. David advised he has not heard from the customer since picking up the vehicle on 7/31/12.

<< Left voice mail for customer to call back regarding his repaired vehicle and also an offer I would like to make. HC616

*** If the customer should call, please request them to contact Harlan Cooper at 888-542-7239, extension 536. Thank you. ***

Customer called back stating his sunroof no longer makes noise, however his passenger side front door still has an issue with sticking. Customer advised he told the service department about this concern on his last visit. According to the repair order invoice, they addressed his concern but did not attempt a repair. Customer stated he was informed by his service advisor David the problem was addressed and solved. Customer is confused as to whether or not the Dealer addressed his concern because his service advisor is saying yes but the repair order invoice does not mention the repair. Customer stated his passenger side front door still sticks and he has another appointment for this Friday 8/10. Advised customer I will follow up with the dealer and the invoice confusion and will call back on Friday 8/10 with an update. Customer thanked me. HC616
8/10/12 Spoke to customer about his pending appointment. Customer advised he was able to drop the vehicle of this morning at Westbury CDJ (23153). Customer spoke to Service Advisor Dave and they believe the issue is when they repaired the vehicle two visits ago, there was some residue left in the cracks of the door. Their plan is to clean out the residue and replace the weather stripping. Advised customer I will try to contact (23153) later today to get an update. Customer advised he is in a loaner and hopes to get his vehicle back today. HC616

8/10/12 Called customer regarding a vehicle update. Customer advised he did call Westbury CDJ (23153) and they advised customer they have to order weather stripping so they need the customer to pick up his vehicle today and bring it back when the weather stripping arrives. The customer is extremely upset because this is his biggest issue. Going back and forth to the dealer over and over again. According to the customer the dealer said the part should arrive in a day or two. Advised customer I will call the dealer and make sure their part is on schedule. Customer thanked me. HC616

8/14/12 Spoke to customer to follow up. Customer advised the dealer informed him the weather stripping should arrive Wednesday or Thursday of this week. Advised customer I will follow up with him after the vehicle repair. Advised customer I want to make sure he is completely satisfied with the repair before I start to process his service contract and one month payment reimbursement. Customer understood and thanked me for following up. Customer stated he really appreciated the service contract offer and one month payment reimbursement. HC616

8/20/12 Spoke to customer to follow up. Customer advised he called Westbury (23153) Friday 8/17 to check on his weather-stripping. He was told by Service Advisor Dave the weather-stripping has not come in. Customer is baffled by this news because it only took them one day to get a sunroof replacement but it is taking over a week to get the weather-stripping. Customer is not happy at all with the lack of service. Customer feels as if his needs are being placed on the back burner. Customer stated he believes they never order the weather-stripping. Advised customer I will try to contact the dealer and will call back as soon as I have an update. Customer thanked me. HC616

*** If the customer should call, please request them to contact Harlan Cooper at 888-542-7239, extension 536. Thank you. ***

8/20/12: Sent email to Tim, Service Manager at Westbury JCD: 'Good morning Tim, Can you please review the following and respond accordingly: A) Customer would like to know why his replacement sunroof only took a day to arrive, but the Weather-stripping is taking more than a week. B) Customer alleges he was advised the Weather-stripping was going to be arriving on 8/15, but has yet to receive a call back to confirm, so he

feels as if he is being forgotten. Thanks.' ** Follow-up 8/21 ** mb981

*** If the customer should call, please request them to contact Harlan Cooper at 888-542-7239, extension 536. Thank you. ***

8/20/12: Received an email from Tim, Service Manager at Westbury JCD: 'Hi Mikelyn, The reason the sunroof took one day is that the local warehouse had the part in stock. We had to order the weather-strip, the part has arrived and I will have the appointment cord call the customer tomorrow and set up an appointment...' Emailed hc616 to advise. mb981

*** If the customer should call, please request them to contact Harlan Cooper at 888-542-7239, extension 536. Thank you. ***

8/21/12 Called customer to give an update. Advised customer the weather strip has arrived and the appointment coordinator should be contacting him today to set up an appointment. Customer thanked me so much for the update. Customer stated he does not know why Westbury JCD wouldn't call him. Advised customer to call back if he needs anything. Customer thanked me again. HC616

*** If the customer should call, please request them to contact Harlan Cooper at 888-542-7239, extension 536. Thank you. ***

8/24/12 Spoke to customer to follow up. Customer advised the dealer, Westbury CDJ did call him. They advised they are extremely busy and if he wants his vehicle back the same day without being placed in a loaner then Tuesday 8/28 is their earliest available time. Customer advised he will bring his vehicle by Tuesday morning 8/28. Advised customer I will follow up with him Wednesday 8/29. Customer thanked me. HC616

*** If the customer should call, please request them to contact Harlan Cooper at 888-542-7239, extension 536. Thank you. ***

8/29/12 Called customer to follow up. Customer advised everything went according to plan. His vehicle has been repaired. Advised customer I will like him to test drive the vehicle and I will follow up with him again on Tuesday 9/04. Advised customer if everything is OK then I will discuss the one month payment reimbursement and service contract. Customer thanked me. HC616

*** If the customer should call, please request them to contact Harlan Cooper at 888-542-7239, extension 536. Thank you. ***

9/04/12: Spoke to customer to follow up. Customer advised so far so good with his vehicle. Advised customer for his time and patience with the repair process I would like to offer him a one month payment reimbursement as well as a Maximum Care 6 years/ 70,000 miles \$100 deductible plan. Customer accepted both offers. Advised customer once the check has been issued and mailed I will call him back and the same goes for the service contract. Customer thanked me for all my help and stated he appreciates the effort. HC616

*** If the customer should call, please request them to contact Harlan Cooper at 888-542-7239, extension 536. Thank you. ***

9/5/12 Emailed rw100 for approval to apply the Chrysler Service Contract to the customer's vehicle. Follow up on service contract approval on 9/7/12. CM

***** Below Customer Contacted for Documentation Request *****

cmackey@impartialservices.com on 2012-09-05 @ 12:20

9/5/12 Emailed tjb16 and rw100 the customer's payment check has been submitted and approved in the amount of \$579.55. Follow up regarding reimbursement on 9/7/12. CM

***** Customer Document Received *****

9/5/12 Received approval from rw100 to process the Chrysler Service Contract. The Chrysler Service Contract applied was the Max Care Plus 6 year/70,000 mile with a \$100.00 deductible. Contract code WM670N. CM Ck # [REDACTED] was received and sent to the payee via US Mail.

9/6/12 Received email from rw100 confirming customer's payment reimbursement in the amount of \$579.55 has been issued and mailed to the customer. CM

9/06/12 Left a voice mail for customer stating his service contract for the Max Care 6 years/70,000 miles with a \$100.00 deductible plan has been applied. Advised customer he should be receiving a packet in the mail within 6 to 8 weeks. Also informed the customer his one month payment reimbursement of (579.55) has been issued and mailed. Thanked the customer for his time and patience with the repair process and advised

him to keep my contact information and to call if he has vehicle issues down the road. Customer is satisfied with the repair, the Max Care 6 years/70,000 miles with a \$100.00 deductible plan and the one month payment reimbursement (579.55). When I spoke to the customer on 9/04, the customer confirmed he was satisfied with the repair. ***CLOSING CAIR***
HC616

*** If the customer should call, please request them to contact Harlan Cooper at 888-542-7239, extension 536. Thank you. ***

9/24/2012 8:48:43 AM: User Comment by Mikelyn Buys: 9/24/12: Opened new CAIR and I2R Case 22647251 to further assist customer. mb981

Customer Assistance Inquiry Record (CAIR)#

22474855

VIN	1C4RJEA66	CC [REDACTED]	Open Date	07/30/2012	Built Date	01/23/2012
Model Year	2012	Body	WKTH74	JEEP GRAND CHEROKEE LAREDO 4X2 SPORT UTILITY		
In Service Dt	04/19/2012	Mileage	100	Dealer Zone	71	LOS ANGELES
Plant	C	JEFFERSON NORTH ASSEMBLY PLANT	Market	U	US	
Color	PXR	BRILLIANT BLACK CRYSTAL PEARL COAT				
Engine	ERB	3.6L V6 24V VVT ENGINE				
Transmission	DGJ	5-SPEED AUTO W5A580 TRANSMISSION				
Dealer	24100	HUNTINGTON BEACH CHRYSLER JEEP				
Dealer Address	16701 BEACH BLVD					
Dealer City	HUNTINGTON BEACH			Dealer State	CA	Dealer Zip 92647
Owner	[REDACTED]				Contact Type	TELEPHONE
Address	[REDACTED]				Home Phone	[REDACTED]
	NEWPORT BEACH CA [REDACTED]				Country	UNITED STATES

Corporate - Survey By-Pass - T2 Email - Default - Default	DM T2 email received
Product - Unknown - Unknown - Fire - Unknown	Fire occurred in vehicle.
Product - Unknown - Unknown - Fire - Interior	Fire occurred near sun visor.
Corporate - Property Damage - Default - Default - Default	
Dealer - By-Pass - Default - Default - Default	

***** Below Customer Contacted for Documentation Request *****

sm1203@chrysler.com on 2012-07-30 @ 16:02

*****Dealer T2 email received*****

Vehicle is currently at Huntington Beach CJD 24100 and photo taken by service manager Ken Brookins.

Writer reviewed and sent case to SI.

***** Customer Document Received *****

Fire occurred in vehicle. sunvisor area.

VEHICLE IS LOCATED AT:

HUNTINGTON BEACH CHRYSLER DODGE CJDTR

16701 BEACH BLVD HUNTINGTON BEACH CA 92647 714-841-3999

Per OGC Matrix, reassigned to 82T.

7/31/12 ASSIGNED TO RLG92. PAG

CAIR NUMBER 22474855 REQUEST EAA INSPECTION 07-31-2012 09:29

CAIR NUMBER 22474855 E-MAIL SENT TO EAA 07-31-2012 09:29

CCRG Open Date: 07/31/2012 07:36:19

Letter Sent: Acknowledgement 08/01/2012 10:52:52

PHOTOGRAPHIC IMAGES POSTED TO THIS CAIR ON 08/08/12 AT 15:03:55 22474855

Briefly summarize why the customer is contacting Chrysler:2012 caught on

fire. Sent to dealership contacted Chrysler. It has been 2 weeks, he

got a letter in the mail. It says that he would get an answer in 12

business days. It has been that long and he has not gotten any further

information. Have called the number listed on the letter but no one ever

answers, even when he calls within the business hours.

Briefly summarize what the customer is expecting: requesting to speak

with someone about this cair

Agent advised as per Answer ID 17117 agent will reopen the CAIR, update the narrative, and advise of the request. No promises were made about when they will be contacted.

Reassigning the CAIR to 82S

Owner requesting update.

Per OGC Matrix, reassigned to 82T.

8/20/12 UPDATED CCRG FILE & CASE MANAGER. PAG

Customer Assistance Inquiry Record (CAIR)#**22557049**

VIN	1C4SDJDT2	CO [REDACTED]	Open Date	08/24/2012	Built Date	03/15/2012
Model Year	2012	Body	WDEH75	DODGE DURANGO CREW AWD SPORT UTILITY 4-DR		
In Service Dt	07/10/2012	Mileage	1,420	Dealer Zone	74	DENVER
Plant	C	JEFFERSON NORTH ASSEMBLY PLANT	Market	U	US	
Color	PDM	MINERAL GRAY MET. CLEAR COAT				
Engine	EZH	5.7L V8 HEMI MDS VVT ENGINE				
Transmission	DG1	6-SPD AUTOMATIC 65RFE TRANSMISSION				

Dealer	26519	PRO CHRYSLER JEEP
---------------	-------	-------------------

Dealer Address	1800 WEST 104TH AVE					
-----------------------	---------------------	--	--	--	--	--

Dealer City	THORNTON	Dealer State	CO	Dealer Zip	80234	
--------------------	----------	---------------------	----	-------------------	-------	--

Owner	[REDACTED]	Contact Type	TELEPHONE
--------------	------------	---------------------	-----------

Address	[REDACTED]	Home Phone	[REDACTED]
----------------	------------	-------------------	------------

ARVADA CO [REDACTED]	Country	UNITED STATES
----------------------	----------------	---------------

Product - Unknown - Unknown - Fire - Engine Compartment	Customers vehicle caught on fire
Corporate - Property Damage - Default - Default - Default	
Dealer - By-Pass - Default - Default - Default	
Product - Unknown - Unknown - Fire - Unknown	

1. Who is calling and what is their contact information? [REDACTED]

Preferred [REDACTED]

Alternate [REDACTED]

2. What happened? He was driving his Durango and it began to smoke and caught on fire with him and his 2 kids in the car

3. What is the current location of the vehicle?

Pro Chrysler Jeep Dodge

1800 W 104th ave

Denver , CO 80234-3602

877-280-3431

-

Reassign to 96S

Please be advised that Pro CJD replaced headliner on 7/31/12.

AM Chris called in and inquired how long the response would be from 86s,

special investigations, writer stated normally one business day.

Fire, refer to 82s

08.27.12

>> case is being forwarded to Chrysler Legal (CCRG) (2-5 days contact)

VEHICLE LOCATED AT:

Pro Chrysler Jeep Dodge

1800 W 104th ave

Denver , CO 80234-3602

877-280-3431

8/27/12 ASSIGNED TO RLG92. PAG

CAIR NUMBER 22557049 REQUEST EAA INSPECTION 08-27-2012 16:10

CAIR NUMBER 22557049 E-MAIL SENT TO EAA 08-27-2012 16:10

Letter Sent: Acknowledgement 08/28/2012 09:46:54

PHOTOGRAPHIC IMAGES POSTED TO THIS CAIR ON 09/04/12 AT 20:07:11 22557049

Customer Assistance Inquiry Record (CAIR)#

22605939

VIN	1D4SE5GT5 BC [REDACTED]	Open Date	09/10/2012	Built Date	04/09/2011
Model Year	2011	Body	WDEP75	DODGE DURANGO CITADEL AWD SPORT UTILITY 4-DR	
In Service Dt	09/13/2011	Mileage	11,000	Dealer Zone	51 CHICAGO
Plant	C	JEFFERSON NORTH ASSEMBLY PLANT	Market	U	US
Color	PAV	DK. CHARCOAL PEARL COAT			
Engine	EZH	5.7L V8 HEMI MDS VVT ENGINE			
Transmission	DGQ	5-SPD AUTOMATIC 545RFE TRANSMISSION			

Dealer	44309	CROWN MOTORS
---------------	-------	--------------

Dealer Address	970 WOODLAWN DR				
-----------------------	-----------------	--	--	--	--

Dealer City	FARMINGTON	Dealer State	MO	Dealer Zip	63640
--------------------	------------	---------------------	----	-------------------	-------

Owner	[REDACTED]	Contact Type	TELEPHONE
--------------	------------	---------------------	-----------

Address	[REDACTED]	Home Phone	[REDACTED]
----------------	------------	-------------------	------------

FARMINGTON MO [REDACTED]	Country	UNITED STATES
--------------------------	----------------	---------------

Product - Unknown - Unknown - Fire - Unknown	front of sunroof
Corporate - Property Damage - Default - Default	
Dealer - By-Pass - Default - Default - Default	

1. Who is calling and what is their contact information? Customer Mrs

Preferred: [REDACTED] (cell) requested by customer

Alternate: [REDACTED] (cell) requested by customer

2. What happened? Customer states she started her vehicle and had a fire start in front of the sunroof

3. What is the current location of the vehicle? Crown Motors 44309

Reassigning to 96S for further handling.

fire, refer to 82s

VEHICLE IS LOCATED AT:

CROWN MOTORS CJDTR

970 WOODLAWN DR FARMINGTON MO 63640 573-431-7800

Per OGC Matrix, reassigned to 82T.

9/13/12 ASSIGNED TO RLG92. PAG

CAIR NUMBER 22605939 REQUEST EAA INSPECTION 09-13-2012 11:21

CAIR NUMBER 22605939 E-MAIL SENT TO EAA 09-13-2012 11:22

PHOTOGRAPHIC IMAGES POSTED TO THIS CAIR ON 09/14/12 AT 15:08:03 22605939

CCRG Open Date: 09/12/2012 15:48:14

Letter Sent: Acknowledgement 09/14/2012 11:00:55

Customer Assistance Inquiry Record (CAIR)#

22904397

VIN	1C4RJFAG0 DC [REDACTED]	Open Date	12/18/2012	Built Date	10/02/2012
Model Year	2013	Body	WKJH74	JEEP GRAND CHEROKEE LAREDO 4X4 SPORT UTILITY	
In Service Dt	11/30/2012	Mileage	600	Dealer Zone	51 CHICAGO
Plant	C	JEFFERSON NORTH ASSEMBLY PLANT	Market	U	US
Color	PXR	BRILLIANT BLACK CRYSTAL PEARL COAT			
Engine	ERB	3.6L V6 24V VVT ENGINE			
Transmission	DGJ	5-SPEED AUTO W5A580 TRANSMISSION			
Dealer	44588	HELLER MOTORS INC			
Dealer Address	720 S DEERFIELD RD				
Dealer City	PONTIAC	Dealer State	IL	Dealer Zip	61764
Owner	[REDACTED]	Contact Type	TELEPHONE		
Address	[REDACTED]	Home Phone	[REDACTED]		
	DWIGHT IL [REDACTED]	Country	UNITED STATES		

Product - Unknown - Unknown - Fire - Interior	Dealer states interior of vehicle caught on fire.
Corporate - Property Damage - Default - Default - Default	
Dealer - By-Pass - Default - Default - Default	
Product - Unknown - Unknown - Fire - Unknown	

1. Who is calling and what is their contact information? Jaime SM from dealer 44588 815-842-1128

Preferred [REDACTED] Owners cell number

Alternate: [REDACTED] wife s cell number

2. What happened? Caller states that [REDACTED] (the wife of the owner) went into the grocery store and when she came out, the vehicle was on fire. Caller states that the vehicle was towed to his dealership after the fire department put the fire out.

3. What is the current location of the vehicle?

720 S Deerfield Road
Pontiac, IL 61764

Vehicle was towed to dealer.

Escalated to 82S

12.18.12

>> case is being forwarded to Chrysler Legal (CCRG) (2-5 days contact)

VEHICLE LOCATED AT:

HELLER MOTORS INC

720 S DEERFIELD RD PONTIAC IL 61764 815-842-1128

Per OGC Matrix, reassigned to 82T. MG17

12/18/12 ASSIGNED TO RLG92. PAG

CAIR NUMBER 22904397 REQUEST EAA INSPECTION 12-18-2012 13:42

CAIR NUMBER 22904397 E-MAIL SENT TO EAA 12-18-2012 13:43

CCRG Open Date: 12/18/2012 11:15:43

Letter Sent: Acknowledgement 12/19/2012 09:55:47

PHOTOGRAPHIC IMAGES POSTED TO THIS CAIR ON 12/24/12 AT 04:16:49 22904397

AM contacted by Dealer-operator, M Heller to inquire status that can be

relayed to customer. AM contacted ISG and left V-mail requesting information.

Customer Assistance Inquiry Record (CAIR)#

23166478

VIN	1C4RJFAGX	CO [REDACTED]	Open Date	03/04/2013	Built Date	10/21/2011
Model Year	2012	Body	WKJH74	JEEP GRAND CHEROKEE LAREDO 4X4 SPORT UTILITY		
In Service Dt	10/21/2011	Mileage	26,114	Dealer Zone	42	DETROIT
Plant	C	JEFFERSON NORTH ASSEMBLY PLANT	Market	U	US	
Color	PS2	BRIGHT SILVER METALLIC CLEAR COAT				
Engine	ERB	3.6L V6 24V VVT ENGINE				
Transmission	DGJ	5-SPEED AUTO W5A580 TRANSMISSION				

Dealer	49983	MAROONE DODGE % CARTEMPS
---------------	-------	--------------------------

Dealer Address	8600 PINES BOULEVARD					
-----------------------	----------------------	--	--	--	--	--

Dealer City	PEMBROKE PINES	Dealer State	FL	Dealer Zip	33024	
--------------------	----------------	---------------------	----	-------------------	-------	--

Owner	[REDACTED]	Contact Type	LETTER
--------------	------------	---------------------	--------

Address	[REDACTED]	Home Phone	[REDACTED]
----------------	------------	-------------------	------------

	INCLINE VILLAGE NV [REDACTED]	Country	UNITED STATES
--	-------------------------------	----------------	---------------

Corporate - Property Damage - Default - Default - Default	
Dealer - By-Pass - Default - Default - Default	
Product - Unknown - Unknown - Accident - Default	
Product - Unknown - Unknown - Fire - Interior	
Product - Unknown - Unknown - Fire - Unknown	
Referral - Top Care - Executive Team - Executive - Sergio Marchionne	

3/4 - thermal issue; reassigning to 82S for followup
 POSTMARK DATE: 030413; DATE RECEIVED: 030513
 Owner claims smoke inhalation injuries, settlement in process with insurance company on vehicle, but not yet resolved. Owner indicates fire first noticed in headliner near windshield header.

VEHICLE IS LOCATED AT:
 Tipton s Auto Parts
 39991 E Hwy 80, Tacna, AZ 85352
 (928) 785-4659

 Per OGC Matrix, reassigned to 82T.
 3/5/13 ASSIGNED TO RLG92. PAG
 CAIR NUMBER 23166478 REQUEST EAA INSPECTION 03-05-2013 14:34
 CAIR NUMBER 23166478 E-MAIL SENT TO EAA 03-05-2013 14:34
 CCRG Open Date: 03/05/2013 13:34:54
 Letter Sent: Acknowledgement 03/06/2013 14:32:19
 PHOTOGRAPHIC IMAGES POSTED TO THIS CAIR ON 03/11/13 AT 04:18:44 23166478

Customer Assistance Inquiry Record (CAIR)#

23187984

VIN	1C4SDHCT1 DC [REDACTED]	Open Date	03/11/2013	Built Date	11/08/2012
Model Year	2013	Body	WDDS75	DODGE DURANGO R/T RWD SPORT UTILITY 4-DR	
In Service Dt	03/06/2013	Mileage	350	Dealer Zone	63 DALLAS
Plant	C	JEFFERSON NORTH ASSEMBLY PLANT	Market	U	US
Color	PDM	MINERAL GRAY MET. CLEAR COAT			
Engine	EZH	5.7L V8 HEMI MDS VVT ENGINE			
Transmission	DG1	6-SPD AUTOMATIC 65RFE TRANSMISSION			
Dealer	43940	ALL STAR DODGE INC			
Dealer Address	2590 RANGE PARK DRIVE				
Dealer City	DENHAM SPRINGS	Dealer State	LA	Dealer Zip	70726
Owner	[REDACTED]	Contact Type	TELEPHONE		
Address	[REDACTED]	Home Phone	[REDACTED]		
	DENHAM SPRINGS LA [REDACTED]	Country	UNITED STATES		

Product - Unknown - Unknown - Fire - Interior	Vehicle fire incident.
Corporate - Property Damage - Default - Default	
Dealer - By-Pass - Default - Default - Default	
Product - Electrical - Body Wiring - Burned Out - Default	
Product - Unknown - Unknown - Fire - Unknown	

1. Who is calling and what is their contact information? The vehicle owner, [REDACTED] is calling.

Customer Address: [REDACTED], Denham Springs, Louisiana [REDACTED]

Preferred: [REDACTED] U [REDACTED] s cell)

Alternate: [REDACTED] [REDACTED] s cell)

2. What happened?

The customer [REDACTED] stated that she had taken ownership of the vehicle last Wednesday. [REDACTED] stated that not much more than approximately 350 miles had been put on the vehicle leading up to this incident. [REDACTED] stated the vehicle had 211 miles approximately at time of purchase. [REDACTED] stated that after taking ownership of the vehicle the visor mirror lamps had not been working and the dome lights worked intermittently. The customer stated that after a short drive from their old house into the driveway of the new one they are moving to the vehicle was burning when the customer got out of the car. The customer stated that the source was inside of their vehicle, above the passenger side visor, where there was a round burn area of a red circle of embers.

3. What is the current location of the vehicle? The vehicle is in transit to All Star Dodge Chrysler Jeep Ram, 2590 Range Park Drive Denham Springs, LA 70726. Phone: (225) 665-8266

This writer informed the customer that the file requires reassignment to another department for further review and special handling and they will follow up within 2-5 business days, by phone or mail. There were no promises on inspections, rental, or repairs made at this time.

Reassigned to 82S.

Customer called in stating that the vehicle that is involved in the

special investigation is located at 30822 Carey Oneal Road, DENHAM SPRINGS , LA. This is a home she used to own and has sold. The new owners will be moving in any day and she has to have the vehicle removed from the property as soon as possible. All Star Dealership was going to pick the vehicle up however someone from Chrysler called and advised the vehicle could not be moved. Writer spoke with a TL and was advised to have the vehicle moved to the dealership lot. Writer contacted the dealership and the service manager was not in the office. Writer left a message requesting the SM call us back. SM needs to be informed of the situation and that the vehicle needs to be removed from its current location. Writer left case number and Dodge's phone number on the voicemail.

NOTE: Micky Benoit is the Service Manager at All-Star Dodge. The dealership shares a call center among 13 other businesses. A direct line to the dealership is 225-490-1787.

SM Mickey called in to ask if we have it documented that the vehicle is being moved to his dealer. Agent read out lines 18-20.

03.13.13

>> case is being forwarded to Chrysler Legal (CCRG) (2-5 days contact)

VEHICLE LOCATED AT:

ALL STAR DODGE CHRYSLER JEEP RAM
2590 RANGE PARK DRIVE
DENHAM SPRINGS LA 70726
225-665-8266

Per OGC Matrix, reassigned to 82T. MG17

Customer called in wanting information on what is going to happen next. Writer advised to allow the full 5 business days for a call back.

3/13/13 ASSIGNED TO RLG92. PAG

CAIR NUMBER 23187984 REQUEST EAA INSPECTION 03-13-2013 11:29

CAIR NUMBER 23187984 E-MAIL SENT TO EAA 03-13-2013 11:29

██████████ called in wanting to know if a case manager had been assigned to her case yet. Agent informed customer that the inspection request was just done today and to give the Case Manager another 48 hours to see if the case manager contacts her back. Agent advised customer that if she does not get a call back by Friday to give us a call back and we will see if there is any new information noted on her account.

The customer called back stating that she has not yet heard back from a CM as promised. The agent advised the customer that the case is currently being handled and the customer will receive a call when all the required information is received.

CCRG Open Date: 03/13/2013 08:50:33

Letter Sent: Acknowledgement 03/14/2013 10:13:54

The customer called stating she was expecting a call back today. The writer referred to line 54.

Customer states that she is looking for the status of the CAIR.

Agent advised that there has been a letter mailed out on the 14th (as per line 69). Agent advised that there will be more information in the letter.

Customer called in seeking an update on her case. Customer stated that an inspector had already come out and inspected the vehicle and submitted their findings. Customer stated that she is going to have a payment due before any contacts her and the vehicle is not even in her possession as its all burnt up. Customer stated that the letter advised her she needed to wait 12 days and she is upset about this. Customer would like a call back as soon as possible with an update.

PHOTOGRAPHIC IMAGES POSTED TO THIS CAIR ON 03/20/13 AT 18:54:06 23187984

Customer Assistance Inquiry Record (CAIR)# **23323209**

VIN	1C4RJEAGX	CO [REDACTED]	Open Date	04/15/2013	Built Date	02/06/2012
Model Year	2012	Body	WKTH74	JEEP GRAND CHEROKEE LAREDO 4X2 SPORT UTILITY		
In Service Dt	03/05/2012	Mileage	24,700	Dealer Zone	70	
Plant	C	JEFFERSON NORTH ASSEMBLY PLANT	Market	U	US	
Color	PW1	STONE WHITE CLEAR COAT				
Engine	ERB	3.6L V6 24V VVT ENGINE				
Transmission	DGJ	5-SPEED AUTO W5A580 TRANSMISSION				

Dealer 67858 MOORE CHRYSLER-JEEP INC

Dealer Address 8600 W BELL RD

Dealer City PEORIA **Dealer State** AZ **Dealer Zip** 85382

Owner [REDACTED] **Contact Type** TELEPHONE

Address [REDACTED] **Home Phone** [REDACTED]

SUN CITY AZ [REDACTED] **Country** UNITED STATES

Dealer - By-Pass - Default - Default - Default	fire in interior
Product - Unknown - Unknown - Fire - Interior	fire in interior
Corporate - Property Damage - Default - Default - Default	
Product - Unknown - Unknown - Fire - Unknown	

1. Who is calling and what is their contact information? [REDACTED]
 Preferred [REDACTED]

Alternate:same as above

2. What happened? Customer Driving and notice a weird smell and smoke coming out the right visor passenger side and burst into flames from the ceiling and melted down to the seat starting a fire on the seat

3. What is the current location of the vehicle?

Moore Collision center
 8577 west kelton lane
 Peoria Az 85382
 6235832037

Per OGC Matrix, reassigned to 82T.
 4/16/13 ASSIGNED TO RLG92. PAG
 CAIR NUMBER 23323209 REQUEST EAA INSPECTION 04-16-2013 09:33
 CAIR NUMBER 23323209 E-MAIL SENT TO EAA 04-16-2013 09:33
 Customer called in for a status update and to see if there was any more information required. Agent advised that the case has been assigned and is in the process. Customer was thankful for the information.
 PHOTOGRAPHIC IMAGES POSTED TO THIS CAIR ON 04/16/13 AT 15:35:21 23323209
 CCRG Open Date: 04/16/2013 07:27:53
 Letter Sent: Acknowledgement 04/17/2013 09:53:12
 Customer seeking information on claim. Agent advised of a letter being sent out to her on 4/17/13 but have no idea what is contained in that letter. Customer will wait to receive letter.
 PHOTOGRAPHIC IMAGES POSTED TO THIS CAIR ON 04/19/13 AT 04:18:23 23323209
 Customer wanted to get an update for her case. Agent tried to contact

JSS15, but received voicemail. Customer will call back later.
Owner calls for status update. 803-634-0474
Per OGC Matrix, reassigned to 82T.
4/23/13 UPDATED CCRG FILE & CASE MANAGER. PAG _

Customer Assistance Inquiry Record (CAIR)#

23548432

VIN	1C4SDJCT1	CC [REDACTED]	Open Date	06/11/2013	Built Date	03/01/2012
Model Year	2012	Body	WDES75	DODGE DURANGO R/T AWD SPORT UTILITY 4-DR		
In Service Dt	12/22/2012	Mileage	550	Dealer Zone	63	DALLAS
Plant	C	JEFFERSON NORTH ASSEMBLY PLANT		Market	U	US
Color	PRM	REDLINE 2 COAT PEARL				
Engine	EZH	5.7L V8 HEMI MDS VVT ENGINE				
Transmission	DG1	6-SPD AUTOMATIC 65RFE TRANSMISSION				
Dealer	26333	BOB HOWARD CHRYSLER JEEP DODGE				
Dealer Address	13250 NORTH BROADWAY EXTENSION					
Dealer City	OKLAHOMA CITY			Dealer State	OK	Dealer Zip 73114
Owner	[REDACTED]				Contact Type	TELEPHONE
Address	[REDACTED]				Home Phone	[REDACTED]
	OKLAHOMA CITY OK [REDACTED]				Country	UNITED STATES

Corporate - Property Damage - Default - Default - Default	
Dealer - By-Pass - Default - Default - Default	
Product - Unknown - Unknown - Fire - Unknown	

1. Who is calling and what is their contact information? Owner, [REDACTED]

Preferred: [REDACTED]
 Alternate: [REDACTED]
 Email: [REDACTED]

2. What happened? Customer states that yesterday [REDACTED] the vehicle caught fire inside the vehicle while driving it. Customer states that the vehicle is currently at dealer 26333. Customer states that she is going on vacation and would need a rental vehicle from June 13th, 2013- June 24th, 2013. Customer states that dealer 26333 advised her to call Chrysler.

Agent contacted dealer 26333 and spoke with SA Jim. Jim advised that the SM contacted the area manager and they are sending some to come and look at the vehicle. Agent asked customer if they would be able to provide rental as the customer is still within warranty under D-11-53. Jim advised that the district manager advised that they can provide the customer with a rental they would just first need Chrysler to authorize it. Agent advised Jim that under D-11-53 the dealer is now empowered to authorize a rental for up to 5 days. Jim advised they are listening to their district manager and will wait until Chrysler authorizes the rental. Agent advised customer that I am going to look into this and once I do I will call back.

Customer s preferred call back number: [REDACTED]

Agent contacted customer back and advised that since there was a fire we would not be able to provide a rental as we have to send the case up to Special Investigations. Agent advised customer that she may have to pay for the rental vehicle and once the vehicle has been investigated she would be able to submit for possible reimbursement. Agent advised

customer that SI will contact her within 2-5 business days. Customer states that she will be on vacation in the mountains and there may not be good reception so to call or email.

3. What is the current location of the vehicle? BOB HOWARD CHRYSLER
13250 North Broadway Extension
Oklahoma City, OK 73114
(405) 936-8900

Per OGC Matrix, reassigned to 82T.
6/12/13 ASSIGNED TO RLG92. PAG
CAIR NUMBER 23548432 REQUEST EAA INSPECTION 06-12-2013 14:21
CAIR NUMBER 23548432 E-MAIL SENT TO EAA 06-12-2013 14:21
CCRG Open Date: 06/12/2013 10:14:31
Letter Sent: Acknowledgement 06/13/2013 09:48:12
PHOTOGRAPHIC IMAGES POSTED TO THIS CAIR ON 06/17/13 AT 12:19:52 23548432

Customer Assistance Inquiry Record (CAIR)# 23589118

VIN	1C4RJFBT1	CC [REDACTED]	Open Date	06/20/2013	Built Date	02/22/2012
Model Year	2012	Body	WKJP74	JEEP GRAND CHEROKEE LIMITED 4X4 SPORT UTILITY		
In Service Dt	03/27/2012	Mileage	10,700	Dealer Zone	51	CHICAGO
Plant	C	JEFFERSON NORTH ASSEMBLY PLANT	Market	U	US	
Color	PGZ	BLACK FOREST GREEN PEARL COAT				
Engine	EZH	5.7L V8 MDS VVT ENGINE				
Transmission	DG1	6-SPD AUTOMATIC 65RFE TRANSMISSION				

Dealer	44991	DON MILLER DODGE
---------------	-------	------------------

Dealer Address	5822 ODANA ROAD					
-----------------------	-----------------	--	--	--	--	--

Dealer City	MADISON	Dealer State	WI	Dealer Zip	53719	
--------------------	---------	---------------------	----	-------------------	-------	--

Owner	[REDACTED]	Contact Type	TELEPHONE
--------------	------------	---------------------	-----------

Address	[REDACTED]	Home Phone	[REDACTED]
----------------	------------	-------------------	------------

MADISON WI [REDACTED]	Country	UNITED STATES
-----------------------	----------------	---------------

Dealer - By-Pass - Default - Default - Default	fire in interior
Product - Unknown - Unknown - Fire - Interior	fire in interior
Corporate - Property Damage - Default - Default - Default	
Product - Unknown - Unknown - Fire - Unknown	

Briefly summarize why the customer is contacting Chrysler: customer called alleging a fire in vehicle. Agent apologized and determined noone was hurt. Apologized and told customer that the case would be reviewed by special investigations team and they would follow up in 2-5 business days to review and work with the customer to resolve the issue.

Briefly summarize what the customer is expecting: customer expecting SI callback in 2-5 days.

1. Who is calling and what is their contact information?

Preferred: [REDACTED]

Alternate [REDACTED]

2. What happened? customer alleges vehicle was damaged in fire

3. What is the current location of the vehicle?

DON MILLER DODGE CHRYSLER JEEP RAM CJDTR

5802 ODANA RD MADISON WI 53719 608-270-5000

Per OGC Matrix, reassigned to 82T.

6/21/13 ASSIGNED TO RLG92. PAG

CAIR NUMBER 23589118 REQUEST EAA INSPECTION 06-21-2013 10:57

CAIR NUMBER 23589118 E-MAIL SENT TO EAA 06-21-2013 10:57

Customer called back and advised of case number.

CCRG Open Date: 06/20/2013 14:01:22

Letter Sent: Acknowledgement 06/24/2013 08:36:51

PHOTOGRAPHIC IMAGES POSTED TO THIS CAIR ON 06/27/13 AT 17:31:40 23589118

Customer Assistance Inquiry Record (CAIR)# **23625360**

VIN	1J4RR4GT8 BC [REDACTED]	Open Date	06/28/2013	Built Date	03/30/2011
Model Year	2011	Body	WKJH74	JEEP GRAND CHEROKEE LAREDO 4X4 SPORT UTILITY	
In Service Dt	05/02/2011	Mileage	26,000	Dealer Zone	32 NEW YORK
Plant	C	JEFFERSON NORTH ASSEMBLY PLANT	Market	U	US
Color	PS2	BRIGHT SILVER METALLIC CLEAR COAT			
Engine	EZH	5.7L V8 MDS VVT ENGINE			
Transmission	DGQ	5-SPD AUTOMATIC 545RFE TRANSMISSION			

Dealer	66827	PAQUIN MOTORS INC
---------------	-------	-------------------

Dealer Address	2 FRANKLIN PARK W				
-----------------------	-------------------	--	--	--	--

Dealer City	SAINT ALBANS	Dealer State	VT	Dealer Zip	05478
--------------------	--------------	---------------------	----	-------------------	-------

Owner	[REDACTED]	Contact Type	TELEPHONE
--------------	------------	---------------------	-----------

Address	[REDACTED]	Home Phone	[REDACTED]
----------------	------------	-------------------	------------

RICHFORD VT [REDACTED]	Country	UNITED STATES
------------------------	----------------	---------------

Dealer - By-Pass - Default - Default - Default	headliner caught fire right by the drivers side visor
Product - Unknown - Unknown - Fire - Interior	headliner caught fire right by the drivers side visor
Corporate - Property Damage - Default - Default - Default	
Product - Unknown - Unknown - Fire - Unknown	

Briefly summarize why the customer is contacting Chrysler: SM Dave called in from PAQUIN MOTORS INC (66827) on behalf of a customer. Dave states the customer was driving down the road and the vehicle spontaneously ignited and caught fire right around the headliner where driver s side sun visor is. Dave states he thinks it could be an electrical fire.

Briefly summarize why the customer is calling: customer seeking to get an investigator out to the vehicle.

VEHICLE IS LOCATED AT:
 PAQUIN MOTORS INC CJDTR
 2 FRANKLIN PARK W SAINT ALBANS VT 05478 802-524-2147

Per OGC Matrix, reassigned to 82T.
 7/1/13 ASSIGNED TO RLG92. PAG
 CAIR NUMBER 23625360 REQUEST EAA INSPECTION 07-01-2013 15:32
 CAIR NUMBER 23625360 E-MAIL SENT TO EAA 07-01-2013 15:33
 CCRG Open Date: 07/01/2013 12:53:20
 Letter Sent: Acknowledgement 07/02/2013 13:04:49
 PHOTOGRAPHIC IMAGES POSTED TO THIS CAIR ON 07/08/13 AT 17:10:43 23625360

Customer Assistance Inquiry Record (CAIR)#

23858386

VIN	1J4RS4GGX	BC [REDACTED]	Open Date	08/23/2013	Built Date	02/24/2011
Model Year	2011	Body	WKTH74	JEEP GRAND CHEROKEE LAREDO 4X2 SPORT UTILITY		
In Service Dt	05/23/2011	Mileage	21,000	Dealer Zone	63	DALLAS
Plant	C	JEFFERSON NORTH ASSEMBLY PLANT	Market	U	US	
Color	PWL	WHITE GOLD CLEAR COAT				
Engine	ERB	3.6L V6 24V VVT ENGINE				
Transmission	DGJ	5-SPEED AUTO W5A580 TRANSMISSION				
Dealer	43939	RAY BRANDT DODGE CHRYSLER JEEP				
Dealer Address	1660 WESTBANK EXPY					
Dealer City	HARVEY			Dealer State	LA	Dealer Zip 70058
Owner	[REDACTED]				Contact Type	TELEPHONE
Address	[REDACTED]				Home Phone	[REDACTED]
	GRETNA LA [REDACTED]				Country	UNITED STATES

Product - Unknown - Unknown - Fire - Interior	smoke in headliner near visor on driver's side
Corporate - Property Damage - Default - Default	
Dealer - By-Pass - Default - Default - Default	

Caller: MS [REDACTED]
 Agent made no promises or commitments.

1. Who is calling and what is their contact information? [REDACTED]

Preferred: [REDACTED]
 Alternate: [REDACTED]

2. What happened?
 Customer was driving and smelled smoke. There was white smoke coming from the headliner near the visor on the driver's side, so basically above her head. Customer pulled over immediately and got out of the vehicle. She used her cell phone to call a friend, who came out to where she was pulled over. The vehicle had sat for about 15 minutes. There was never an open flame. The visor was hot to the touch. Customer drove the vehicle to the dealership.

3. What is the current location of the vehicle?
 RAY BRANDT DODGE CHRYSLER JEEP RAM
 1660 WESTBANK EXPY
 HARVEY, LA
 504-363-1999

As per AC Answer ID 18819 agent advised the customer: the file requires reassignment to another department for further review and special handling and they will follow up with her within 2-5 business days, by phone or mail.

Agent reviewed file with TL BA215 as per AC 18819.
 As per AC 18819 **** The Federal Government defines fire as 'combustion or burning of any material in a vehicle as evidenced by, but not limited to, flame, smoke, sparks, or smoldering.'

08.23.13

>> case is being forwarded to Chrysler Legal (CCRG) (2-5 days contact)

VEHICLE LOCATED AT: RESIDENCE

MS

GRETNA LA

Per OGC Matrix, reassigned to 82T. MG17

8/26/13 ASSIGNED TO LSE6. PAG

CAIR NUMBER 23858386 REQUEST DEKRA INSPECTION 08-26-2013 14:39

CAIR NUMBER 23858386 E-MAIL SENT TO DEKRA 08-26-2013 14:40

CCRG Open Date: 08/26/2013 14:32:03

Letter Sent: Acknowledgement 08/27/2013 07:48:52

PHOTOGRAPHIC IMAGES POSTED TO THIS CAIR ON 08/30/13 AT 14:03:48 23858386

Customer Promoter Score Report**BC50528003**

VIN	1J4RS5GTXBC [REDACTED]	Model Year	2011	Body	WKTP74	JEEP GRAND CHEROKEE LIMITED 4X2 SPOR UTILITY
Built Date	05/24/2010	Market	U	US	Plant	C JEFFERSON NORTH ASSEMBLY PLANT
Color	PBV	BLACKBERRY PEARL COAT				
Engine	EZH	5.7L V8 MDS VVT ENGINE				
Transmission	DGQ	5-SPD AUTOMATIC 545RFE TRANSMISSION				

Open Date	05/15/2012	Mileage	0	Event	003	1st Service customer pay
Dealer	44107	ACADIANA DODGE CHRYSLER JEEP			Dealer Zone	63
Dealer Address	1700 SOUTHEAST EVANGELINE HIGH				Dealer Phone(s)	337 232-7361
City/State/ZIP	LAFAYETTE, LA, 70508				Dealer Fax	337 232-1523

Q1 How willing are you to recommend JEEP to a friend or colleague?

Score: 00 (Detractor)

992 : Safety/Legal

007 : Negative experience / problems with CURRENT vehicle

Because my jeep is less than a year old and has had to be serviced too many times, and one of the times is because the roof was smoking and would of caught on fire if it was unattended. And now my air conditioner is not working!

Q2 Please rate your satisfaction with your GRAND CHEROKEE LIMITED 4X2 SPORT UTILITY on a scale of 0 to 10.

Score: 02 (Detractor)

P17 : Numerous non-specific problems / already have problems

Because of all the problems I am having!

Q3 Please rate your satisfaction with your experience at ACADIANA DODGE CHRYSLER JEEP on a scale of 0 to 10.

Score: 03 (Detractor)

005 : Lack of communication

I called the owner this week and have not heard back from him yet!

Q14 Do you want Chrysler to contact you?

001 : Legal

Question Not Asked

SURVEY COMPLETED 2012-05-18 21:46:30, CUSTOMER ID:714376092, RO:00022448, CONTACT METHOD:ONLINE, SPEAKING TO NAME FROM SAMPLE, LANGUAGE:00

PE13-027

CHRYSLER

10-7-2013

ENCLOSURE 4

Field Report

QNA - Quality Narrative Analyzer Detail Report

Vehicle Problem Tracking Report#: SSV060139444

Vehicle Information

Repair Information

Dealer Information

VIN: 1J4RR4GG7BC [REDACTED]
Model Year: 2011
Make/Model: JEEP
 GRAND CHEROKEE LAREDO 4X4
 WKJH74
Engine: ERB-3.6L V6 FFV 24V VVT ENGINE (Ser #6263610510)
Transmission: DGJ-5-SPEED AUTO W5A580 TRANSMISSION (Ser #:J024160207)
Plant: JEFFERSON NORTH ASSEMBLY PLANT
MDH: 012723

Report#: SSV060139444
Open Date: 07/14/2013
Mileage: 34575
Warr Built Dt: 01/27/2011
Supplier RP:

Zone/Cd: 35-66479
Name: BERGEY'S CHRYSLER JEEP DODGE
Address: 408 HARLEYSVILLE PIKE
 SOUDERTON, PA 189642141
Phone: 215 721-3490
 215 721-3470

Part Information

Part Number	Part Description	Quantity	Cost/Unit	Fail Cd	Retn Dt
** No Parts Information Available					

Labor Information

LOP	LOP Description	Cost	Fail Cd
08	ELECTRICAL	0.00	

Service Narrative Information

Customer Comment: WIPERS CAME ON BY THEMSELVES AND STAY ON LOW SPEED, STEERING WHEEL BUTTONS DO NOT WORK, NO RESPONSE WITH TERRAIN SELECTOR SWITCH

Service Action: WILLIAM, PER OUR CONVERSATION ON THE PHONE, YOU HAVE REVIEWED 11511963 AND THE PINS AND CONNECTORS ARE OK. YOU STATE THAT LAST NIGHT A TECH HAD DRIVEN THE VEHICLE HOME AND THE HEADLINER CAUGHT ON FIRE AND THE IOD FUSE WAS REMOVED TO REMOVE POWER FROM THE M27 CIRCUIT, FURTHER INSPECTION FOUND THE LEFT FRONT VANITY LAMP SCREW GROUNDING OUT THE M27 CIRCUIT. WE ARE NOT FINDING ANY RELATION FROM THE CIRCUIT M27 TO THE M20 FUSE INTERMITTENTLY BLOWING, OTHER THAN THE CONNECTOR C2 AT THE CLUSTER. YOU STATED YOU ARE GOING TO INSEPECT THE CLUSTER CONNECTORS AND HARNESS FOR ANY ISSUES. SUGGEST TO INSTALL 10 AMP INLINE FUSES IN THE A909 CIRCUIT, SO THAT YOU CAN NARROW DOWN YOUR SOURCE OF THE INTERMITTENT SHORT CAUSING THE BLOWN M20 FUSE, TONY. WIRING BEHIND THE CENTER INSTRUMENT PANEL WAS INSPECTED AND ROUTING OF HARNESS WAS ADJUSTED FOR THE CENTER STACK SWITCH AND ALSO THERE WAS A SHORT IN THE DRIVERS VISOR WIRING FROM ONE OF THE SCREWS FOR THE VISOR THAT MELTED AND CAUSED DAMAGE TO THE HEADLINER AS WELL AS THE DRIVERS SEAT BOTTOM COVER

Correction:

QNA - Quality Narrative Analyzer Detail Report

Vehicle Problem Tracking Report#: SSV012735933

Vehicle Information

Repair Information

Dealer Information

VIN: 1C4RJFCG5CC [REDACTED]
Model Year: 2012
Make/Model: CHRYSLER
 GRAND CHEROKEE OVERLAND 4X4
 WKJS74
Engine: ERB-3.6L V6 FFV 24V VVT ENGINE (Ser #:6026220378)
Transmission: DGJ-5-SPEED AUTO W5A580 TRANSMISSION
 (Ser #:J031260680)
Plant: JEFFERSON NORTH ASSEMBLY PLANT
MDH: 020615

Report#: SSV012735933
Open Date: 11/30/2012
Mileage: 3592
Warr Built Dt: 02/06/2012
Supplier RP:

Zone/Cd: 71-26550
Name: BOB BAKER CHRYSLER JEEP DODGE
Address: 5555 CAR COUNTRY DR
 CARLSBAD, CA 92008
Phone: 760 720-5337

Part Information

Part Number	Part Description	Quantity	Cost/Unit	Fail Cd	Retn Dt
** No Parts Information Available					

Labor Information

LOP	LOP Description	Cost	Fail Cd
08	ELECTRICAL	0.00	

Service Narrative Information

Customer Comment: DRIVER SIDE VANITY LIGHT VERY DIM,PASSENGER SIDE VANITY LIGHT INOP,OVERHEAD LIGHTS DIM.LOOKING AT WIRING DIAGRAM COMMON ISSUE WOULD APPEAR TO BE SPLICE SM27(GLOVE BOX LIGHT BRIGHT)CANNOT LOCATE SPLICE WITH DIAGRAM.IS IT IN THE HEADLINER HARNESS,HAVE THERE BEEN SIMILAR ISSUES.GREAT LACK OF INFO WITH DIAGRAM FOUND PASSENGER SIDE LIGHTED VANITY MIRROR CONNECTOR MELTED AND BOTH WIRES BARELY MELTED TOGETHER CAUSING ENOUGH SHORT TO GROUND DIMMING OTHER LIGHTS .CONNECTOR NOT AVAILABLE. I CAN SUBSTITUTE WITH DIFFERENT CONNECTOR AND REPLACE MBECAUSE HARNESS COMES WITHHEADLINER.LET ME KNOW AND THANKSIRRROR AS OPPOSED TO REPLACING HEADLINER IF THAT IS ACCEPTABLE WAITING FOR NEW VISOR TO SHOW UP WAITING FOR NEW VISOR TO SHOW UP REPAIRED HARNESS AND REPLACED CONNECTOR AS DISCUSSED AND INSTALLED VISOR AND CIRCUIT FINE , LIGHTS ALL GOOD , THANKS

Service Action: ERIC, THAT SPLICE IS LOCATED IN THE HEADLINER ON THE DRIVER S SIDE REAR OF THE HEADLINER ABOVE THE D-PILLAR. THERE IS A PICTURE OF THE SPLICE LOCATION

IF YOU BUILD THE VEHICLE AS A 2013 WK OVERLAND. BE SURE TO ALSO SUPPLY A GOOD GROUND TO ONE OF THE DIM LAMPS TO SEE IF THEY OPERATE NORMALLY. THE GROUND SPLICE FOR THE DIM LAMPS IS ALSO LOCATED IN THE HEADLINER NOT TOO FAR FROM THE OTHER SPLICE. KEEP US POSTED. THANKS, MIKE R. ERIC, BY ALL MEANS, YES. IF YOU HAVE A CONNECTOR THAT WILL WORK ON THAT GO AHEAD AND USE IT. THAT WILL BE BETTER THAN HAVING TO REPLACE THE ENTIRE HEADLINER. LET US KNOW IF YOU NEED ANYTHING ELSE ON THIS ONE. THANKS FOR THE UPDATE ERIC. KEEP ME POSTED WHEN THE PART ARRIVES. GOOD TO HEAR ERIC. FEEL FREE TO CLOSE THE CASE WHEN YOU ARE READY AND LET US KNOW IF YOU NEED ANYTHING ELSE ON THIS. HAVE A GREAT DAY. REPAIRED HARNESS AND CONNECTOR WIRING TO PASSENGER SIDE LIGHTED VANITY MIRROR AND REPLCED VISOR

Correction:

QNA - Quality Narrative Analyzer Detail Report

Vehicle Problem Tracking Report#: SSV012737135

Vehicle Information

Repair Information

Dealer Information

VIN: 1C4RJEAGXC [REDACTED]

Model Year: 2012

Make/Model: CHRYSLER
GRAND CHEROKEE LAREDO 4X2
WKTH74

Engine: ERB-3.6L V6 FFV 24V VVT ENGINE (Ser #6131220189)

Transmission: DGJ-5-SPEED AUTO W5A580 TRANSMISSION (Ser #:J136260179)

Plant: JEFFERSON NORTH ASSEMBLY PLANT

MDH: 051813

Report#: SSV012737135

Open Date: 10/28/2012

Mileage: 2523

Warr Built Dt: 05/18/2012

Supplier RP:

Zone/Cd: 66-45426

Name: ARRIGO DODGE CHRYSLER JEEP RAM

Address: 5901 MADISON AVE
TAMARAC, FL 333216412

Phone: 954 861-6200

Part Information

Part Number	Part Description	Quantity	Cost/Unit	Fail Cd	Retn Dt
** No Parts Information Available					

Labor Information

LOP	LOP Description	Cost	Fail Cd
08	ELECTRICAL	0.00	

Service Narrative Information

Customer Comment: RIGHT LIGHTED SUNVISOR CAUGHT FIRE AND MELTED AND BURNT UP HEADLINER. POSSIBLE SHORT CIRCUIT IN RIGHT VANITY LAMP OR HARNESS. FOUND LEFT VAINTY LIGHT DIM. OK CHECKED THE M20 WITH THE FUSE REMOVED AND POWER IS GONE. ALSO DISCONNECTED THE M27 CONNECTOR. NORMAL OPERATION SHOULD BE RESTORED WITH THE NEW HEADLINER. HEADLINER IS ON ORDER SO UPDATE IS FORTHCOMING.

Service Action: JOHN, WITH THE M20 FUSE REMOVED THERE SHOULD BE NO POWER ON THAT CIRCUIT. IT MAY BE SHORTED TO POWER IN THE HEADLINER. DISCONNECT THE M27 CIRCUIT FROM THE MAIN HEADLINER CONNECTOR AND SEE IF THE POWER GOES AWAY. ALSO INSPECT TO SEE IF THE GLOVE BOX IS WORKING WITH THE M20 REMOVED. REPLACE THE HEADLINER DUE TO THE HARNESS AS WELL AS THE VISOR AND RETEST. MOST CASES FOR THIS ARE DUE TO THE HARNESS BEING PINCHED IN THE HEADLINER AT THE VISORS. KEEP US POSTED. THANKS, MIKE R. THANKS FOR THE UPDATE JOHN. KEEP US POSTED. PARTS ON ORDER

Correction:

QNA - Quality Narrative Analyzer Detail Report

Vehicle Problem Tracking Report#: SSV012524179

Vehicle Information

Repair Information

Dealer Information

VIN: 1C4RJFAG7C0 [REDACTED]

Model Year: 2012

Make/Model: CHRYSLER
GRAND CHEROKEE LAREDO 4X4
WKJH74

Engine: ERB-3.6L V6 FFV 24V VVT ENGINE (Ser #6348111475)

Transmission: DGJ-5-SPEED AUTO W5A580 TRANSMISSION (Ser #:J355160288)

Plant: JEFFERSON NORTH ASSEMBLY PLANT

MDH: 122319

Report#: SSV012524179

Open Date: 08/17/2012

Mileage: 220

Warr Built Dt: 12/23/2011

Supplier RP:

Zone/Cd: 42-58625

Name: MONROE DODGE-CHRYSLER INC

Address: 15160 S MONROE ST
MONROE, MI 481613792

Phone: 734 242-6370

Part Information

Part Number	Part Description	Quantity	Cost/Unit	Fail Cd	Retn Dt
** No Parts Information Available					

Labor Information

LOP	LOP Description	Cost	Fail Cd
08	ELECTRICAL	0.00	

Service Narrative Information

Customer Comment: WIPERS DO NOT OPERATE, COMPASS DOES NOT OPERATE AND ALSO THE UPPER SWITCH BANK WILL NOT OPERATE. OCCASIONALLY WILL BLOW FUSE TO UPPER SWITCH BANK BUT NOT ALWAYS. FOLLOWED STEPS IN TECH CONNECT FOR CODE B2304, I UNPLUGGED THE CONNECTER AT THE FRONT WIPER MOTOR AND THE WITECH SHOWS THAT THE WIPER SENSE IN THE TIPM SAYS NOT PARKED. NOW FOLLOWING TECH CONNECT THAT MEANS I HAVE TO REPLACE THE FRONT WIPER MOTOR IS IT POSSIBLE THAT THE FRONT WIPER MOTOR HAS ANY CORRELATION TO THE OTHER TWO CODES LOOKED UP STAR CASE NUME S1208000046 IN WHICH IT SAYS POSSIBLY A PINCHED HARNESS, I WAS WONDERING IF YOU COULD GIVE ME MORE INFO ON WHERE HIS HARNESS IS LOCATED BECAUSE THE PICTURE AND INFO IN THE CASE DOESNT REALLY GIVE ME ANY CLUES. OK SO I STILL HAVE NOT FOUND THE WIRING HARNESS I HAVE THE CAR TORN APART AND AM LOOKING NEAR THE GAS PEDAL AND THERE IS NO HARNESS GOING NEAR IT, IS IT BEHIND THE IP COVER ALSO THE WIPER PROBLEM I BEILEVE IS A BURNT UP MOTOR THAT WAS CAUSE BY THE LOSS OF COMM TO THE MULTI

FUNCTION SWITCH WHICH WAS CAUSEING THE WIPERS TO DEFAULT ON, JUST A THOUGHT. CAN U GIVE ME MORE DETAIL INFORMATION ON WHERE THE WIREING HARNESS IS AND WHAT EXACTLY THE PROBLEM IS WITH IT. THANKS VOLTAGE OF THE LIN BUS AT THE CLUSTER C1 CONNECTOR IS ONLY .15V WITH KEY ON BUT ENGINE OFF. ALSO HAVE CONTINUITY BETWEEN THE LIN BUS WT/DG WIRE FROM THE CLUSTER TO IGNITION AND FROM UPPER SWITCH BANK TO CLUSTER ANY CLUE ON WHAT THE PROBLEM COULD BE FOUND WIRES AT THE SUN VISOR WERE CORODED AND SHORTED TOGETHER CAUSE THE HARNESS TO BURN UP TAKING OUT THE LIN BUS NEED TO GET A NEW HARNESS AND NEW HEADLINER BECAUSE WIRING BURNED INTO HEADLINER THE WIRING ITSELF WAS CORRODED INSIDE THE WHOLE HARNESS DONT KNOW IF YOU GUYS HAVE SEEN THIS BEFORE DEFINETLY A PROBLEM WITH THE HARNESS THAT WAS FACTORY INSTALLED.

Service Action: ANDREW, THE PICTURE IN THE SOL CASE IS OF THE LEFT SIDE OF THE CENTER CONSOLE WHICH WOULD BE BEHIND THE PANEL NEXT TO THE GAS PEDAL, I DO NOT THINK THIS CASE WILL RESOLE THE WIPER ISSUE SO CONTINUE WITH THE TEST REPAIR FOR THAT CODE JUST MAKE SURE THE TIPM IS SEEING A SWITCH INPUT, I DO THINK YOU HAVE MORE THAN 1 CONCERN WITH THE VEHICLE SO START INSPECTING CONNECTORS AT THE TIPM AND ANY OTHERS YOU CAN FIND AND MAKE SURE EVERY ONE IS CONNECTED FULLY.\r\nPLEASE KEEP ME POSTED.\r\nTHANKS.\r\nMARK. ANDREW, THE CENTER CONSOLE DOES IT GO ALL THE WAY TO THE FLOOR THE SOL CASE WOULD BE BEHIND THE LEFT PANEL LIKE BELOW THE RADIO TOWARDS THE FLOOR, THAT IS THE WAY THE PIC APPEARS TO ME, THIS MAY NOT EVEN APPLY, WHAT IS THE LIN VOLTS AT THE CLUSTER \r\nMARK. ANDREW, START DISCONNECTING MODULES FROM THE LIN CIRCUITS 1 AT A TIME AND MONITOR THE LIN VOLTS, KEY ON SHOULD HAVE AT LEAST 7 VOLTS ON THE LIN.\r\nMARK. ANDREWM GREAT TO HEAR, CAN YOU REPAIR OR IS A NEW DASH HARNESS NEEDED \r\nMARK ANDREW, THIS IS NEW TO ME BUT I WILL PASS THIS INFO AROUND, THANKS FOR THE DETAILS.\r\nMARK. HEADLINER

Correction:

QNA - Quality Narrative Analyzer Detail Report

Vehicle Problem Tracking Report#: SSV012228025

Vehicle Information

Repair Information

Dealer Information

VIN: 1C4RJFAG3CC [REDACTED]

Model Year: 2012

Make/Model: CHRYSLER
GRAND CHEROKEE LAREDO 4X4
WKJH74

Engine: ERB-3.6L V6 FFV 24V VVT ENGINE (Ser #6338110781)

Transmission: DGJ-5-SPEED AUTO W5A580 TRANSMISSION (Ser #:J342160212)

Plant: JEFFERSON NORTH ASSEMBLY PLANT

MDH: 121408

Report#: SSV012228025

Open Date: 05/04/2012

Mileage: 658

Warr Built Dt: 12/14/2011

Supplier RP:

Zone/Cd: 74-44950

Name: ROY'S GRAND DODGE-CHRY-JEEP ON

Address: 1803 SOUTH LOCUST ST
GRAND ISLAND, NE 68801

Phone: 308 384-8300

Part Information

Part Number	Part Description	Quantity	Cost/Unit	Fail Cd	Retn Dt
** No Parts Information Available					

Labor Information

LOP	LOP Description	Cost	Fail Cd
08	ELECTRICAL	0.00	

Service Narrative Information

Customer Comment: DOME LIGHT ARE VERY DIM WITH DOORS CLOSED AND USING INDEPENDENT SWITCHES

Service Action: DOME LIGHT ARE VERY DIM WITH DOORS CLOSED AND USING INDEPENDENT SWITCHES DUPLICATED : YES - DOORS CLOSED IF YOU DROP DOWN SUN VISOR AND LOOK AT VANITY MIRROR LIGHTS BARELY ON MAP LIGHTS THE SAME WAY BUT IF YOU OPEN DOOR OR USE DIMMER SWITCH LIGHTS ARE BRIGHT EXCEPT VANITY LIGHTS REPAIRS AND TESTS PERFORMED : CHECKED TSB S AND IF ANY FLASHES WONDER IF IT IS CONFIGURED CORRECTLY OR WE HAVE A OUTPUT FROM TIPM OR CCN THAT HAS VERY LOW VOLTAGE TECHCONNECT SEARCH : DOME LIGHTS

HELLO, I AM NOT SEEING ANY CASES THAT PERTAIN TO THIS CONCERN. I WOULD SUGGEST VERIFYING THAT THE CIRCUITS LEADING TO THE CLUSTER. AS FOR THE TIPM SUPPLYING VOLTAGE, THE CCN SHOULD CONTROL THE OUT PUT VOLTAGE TO THE LAMPS. THERE WILL BE A FUSED B+ LEAD AT THE CCN AND THEN THE EMIC WILL CONTROL THE NECESSARY VOLTAGE OUT PUT FROM THERE. I WOULD SUGGEST PERFORMING A VOLTAGE DROP

FROM THE CCN OUTPUT TO THE LAMPS AND DETERMINE IF WE HAVE AN OPEN OR SHORT SOMEWHERE. WE MAY HAVE AN INTERNAL CLUSTER PROBLEM BUT I WOULD VERIFY ALL CIRCUITS ABOVE THE HEADLINER AND BEHIND THE CLUSTER FIRST. IF ANY FURTHER ASSISTANCE IS NEEDED FEEL FREE TO CONTACT ME. THANKS BRYAN FOUND LH SUN VISOR WIRING SHORTED TO GROUND REMOVED SUN VISOR AND ONLY HAS 3.5 VOLTS. REMOVE CLUSTER AND HAVE 8.5 COMING OUT OF CLUSTER. FOUND 20 AMP FUSE INSTALLED IN M20 CIRCUIT IN TIPM SHOULD BE 15 AMP FUSE. WIRING IS MELTED TOGETHER AT CONNECTOR AND BACK INTO HARNESS FOR SUN VISOR. REPLACED SUN VISOR AND HEAD LINER AND EVERYTHING WORKS PROPERLY NOW INSTALLED CORRECT SIZE FUSE ALSO.

Correction:

QNA - Quality Narrative Analyzer Detail Report

Vehicle Problem Tracking Report#: SSV012187228

Vehicle Information

Repair Information

Dealer Information

VIN: 1C4RJFCT8CC [REDACTED]
Model Year: 2012
Make/Model: CHRYSLER
 GRAND CHEROKEE OVERLAND 4X4
 WKJS74
Engine: EZH-5.7L V8 HEMI MDS VVT ENGINE (Ser #6337110430)
Transmission: DG1-6-SPD AUTOMATIC 65RFE TRANSMISSI (Ser #:J326111332)
Plant: JEFFERSON NORTH ASSEMBLY PLANT
MDH: 121000

Report#: SSV012187228
Open Date: 04/11/2012
Mileage: 1618
Warr Built Dt: 12/10/2011
Supplier RP:

Zone/Cd: 32-66325
Name: BAYSIDE CHRYSLER DODGE JEEP RA
Address: 21219 NORTHERN BLVD
 BAYSIDE, NY 113613341
Phone: 718 428-8777
 718 229-8700

Part Information

Part Number	Part Description	Quantity	Cost/Unit	Fail Cd	Retn Dt
** No Parts Information Available					

Labor Information

LOP	LOP Description	Cost	Fail Cd
08	ELECTRICAL	0.00	

Service Narrative Information

Customer Comment:VEHICLE HEADLINER AND R/S VISOR ARE DISCOLORED DUE TO TEMPERATURE.....YIKES ANYTHING OUT THERE ABOUT THIS

Service Action:VEHICLE HEADLINER AND R/S VISOR ARE DISCOLORED DUE TO TEMPERATURE.....YIKES ANYTHING OUT THERE ABOUT THIS DUPLICATED : YES - EXTINGISHED BY FDNY
 REPAIRS AND TESTS PERFORMED : N/A TECHCONNECT SEARCH \r\n*****\r\nSTAR SPOKE WITH ROBERT.
 ROBERT STATED THE VEHICLE WAS TOWED IN DUE TO THIS ISSUE. STAR ADVISED ROBERT TO CONTACT THE BUSINESS CENTER AND REPORT THIS CASE. STAR IS
 ESCALATING THIS CASE FOR FURTHER REVIEW. PLEASE PERFORM NO REPAIRS UNTIL CONTACTED - BRIAN ROBERT,\r\n\r\nI AM GOING TO ESCALATE THIS CASE TO THE FTS
 GROUP FOR SAFETY REVIEW. SOMEONE FROM THAT GROUP WILL CONTACT YOU. THANK YOU FOR YOUR PATIENCE.\r\n\r\nMARTIN RECEIVED EMAIL FROM AM JEFF MIREK.
 SUGGESTED HE OPEN/UPDATE CAIR AND SEND TO SPECIAL INVESTIGATIONS TO REQUEST EA DO FIRE INVESTIGATION DEKRA WAS ASSIGNED CASE TO INSPECT K

Correction:

QNA - Quality Narrative Analyzer Detail Report

Vehicle Problem Tracking Report#: SSV011685163

Vehicle Information

Repair Information

Dealer Information

VIN: 1J4RS6GT9BC [REDACTED]
Model Year: 2011
Make/Model: JEEP
 GRAND CHEROKEE OVERLAND 4X2
 WKTS74
Engine: EZH-5.7L V8 HEMI MDS VVT ENGINE (Ser #:6025110886)
Transmission: DGQ-5-SPD AUTOMATIC 545RFE TRANSMISS (Ser #:J055111000)
Plant: JEFFERSON NORTH ASSEMBLY PLANT
MDH: 031420

Report#: SSV011685163
Open Date: 12/06/2011
Mileage: 61
Warr Built Dt: 03/14/2011
Supplier RP:

Zone/Cd: 66-44073
Name: CONWAY CHRYSLER DODGE JEEP INC
Address: 2385 HWY 501 WEST
 CONWAY, SC 295265002
Phone: 843 365-7331

Part Information

Part Number	Part Description	Quantity	Cost/Unit	Fail Cd	Retn Dt
** No Parts Information Available					

Labor Information

LOP	LOP Description	Cost	Fail Cd
08	ELECTRICAL	0.00	

Service Narrative Information

Customer Comment: ABS LIGHT ON AND FWC IS INOP. YES IT IS READING WHEN I SPIN THE WHEEL I CHECKED FOR SHORT TO GROUND AND SHORT TO VOLTAGE NEITHER WAS PRESENT I WAS NOT ABLE TO LOADTEST B1 OR B2 CIRCUIT BECAUSE I COULD NOT GET A CONNECTOR PIN OUT DIAGRAM AT THE ABS MODULE ALSO WAS NOT ABLE TO GET A HARNESS DIAGRAM SO I WOULD KNOW WHERE TO LOOK FOR PINCHED WIRES IF YOU COULD PLEASE SEND THIS INFO SO I CAN DIAG MORE I ALREADY TRIED THE RR SPEED SENSOR AND IT DID NOT FIX THE PROBLEM. I LOAD TESTED BOTH WIRES AND BOTH GAVE ME BRIGHT LIGHT I WAS THINKING IT WAS THE ABS MODULE BECAUSE IT WOULD KEEP RESETTING ITSELF AFTER 1MIN WITH KEY OFF BUT ALSO IT WOULD HAPPEN SOMETIMES IN PARK SO I DON T KNOW ABOUT THAT LET ME KNOW WHAT YOU THINK THANKS ED YES I PUT A SENSOR ON IT THE CODES CAME RIGHT BACK. I CHECKED FOR CONTINUITY BETWEEN BOTH WIRES THEY WERE OPEN NO CONTINUITY PRESENT

Service Action: ABS LIGHT ON AND FWC IS INOP. DUPLICATED : YES - DRIVING FOR 1 MILE LIGHT COMES BACK ON. REPAIRS AND TESTS PERFORMED : I HAVE FLASHED ALL MODULES TO

BRING THEM UP TO DATE. I HAVE ALSO DROPPED THE HEADLINER DUE TO HAIL DAMAGE REPAIRS DONE PREVIOUSLY AND FOUND RIGHT SUNVISOR WIRES PINCHED WHEN I UNPLUGGED IT THE LIGHT WENT OFF. THEN I DROVE IT AND 1 MILE LATER LIGHTS CAME BACK ON THE CODES I HAVE ARE ABS-C003A1D, PCM-U1418, PTS-U0431-00 ALL TELLING ME THAT THE RIGHT REAR SPEED SENSOR IS BAD. I CHECK ALL CONNECTIONS AT SPEED SENSOR ALL SEEM FINE SHOULD I PUT A SPEED SENSOR ON AND SEE WHAT HAPPENS OR DID THE PINCHED WIRES BURN UP THE CIRCUIT. DTCS : C003A1D,U1418,U0431-00 TECHCONNECT SEARCH : ABS.*****\r\n\r\nHELLO ED. WHILE MONITORING THE WITECH DATA FOR THE ABS, IS A WHEEL SPEED SIGNAL PRESENT FOR THE RR. PLEASE RESPOND. THANK YOU. JESSE S. HELLO ED. PLEASE INSPECT ABS CONNECTOR PINS 10 AND 11 FOR TERMINAL INSTALLATION, POSITION, AND CRIMP. PLEASE VERIFY B1 AND B2 CIRCUITS HAVE NOT CONTINUITY TO POWER OR GROUND. USING A HEAD LAMP BULB, PLEASE LOAD TEST THE B1 AND B2 CIRCUITS. IF OK, SUSPECT AN ISSUE WITH THE RR WHEEL SPEED SENSOR. JESSE S. HELLO ED. PER THE WIRING DIAGRAM, THE B1 CIRCUIT (BRK - WHEEL (-) RR RT) IS PIN 10 - DG/OR WIRE AND THE B2 CIRCUIT (BRK - WHEEL (+) RR RT) IS PIN 11 DG/LB - WIRE AT THE ESP MODULE (ABS MODULE). PLEASE LOAD TEST THESE WIRES PER THE PREVIOUS TICKET SUBMISSION AND RESPOND WITH FINDINGS. THANK YOU. JESSE S. ED. AN ABS MODULE IS NOT A COMMON CONCERN WITH THIS VEHICLE. DID YOU PUT A SPEED SENSOR ON IT DID YOU HAVE CONTINUITY BETWEEN THE TWO WIRES JESSE S. ED, PLEASE INSPECT THE TERMINAL FIT AND MAKE SURE THAT THE TERMINAL IS NOT CRIMPED OVER THE INSULATION AT THE ABS MODULE CONNECTOR AND SPEED SENSOR. TO ISOLATE THE ISSUE TO THE ABS MODULE YOU WILL NEED TO SWITCH THE WIRES AT THE ABS MODULE CONNECTOR FOR THE RIGHT REAR AND LEFT REAR SPEED SENSORS (FOR TESTING ONLY THE WIRING WILL NEED TO BE INSTALLED BACK IN ITS ORIGINAL LOCATION BEFORE THE VEHICLE IS RELEASED) IF THE SAME DTC S SET THEN THE MODULE IS SUSPECT. IF DIFFERENT DTC S SET THEN THERE IS A WIRING ISSUE. JESSE S. KA ABS MODULE

Correction:

QNA - Quality Narrative Analyzer Detail Report

Vehicle Problem Tracking Report#: SSV010961131

Vehicle Information

Repair Information

Dealer Information

VIN: 1J4RR5GT0BC [REDACTED]
Model Year: 2011
Make/Model: JEEP
 GRAND CHEROKEE LIMITED 4X4
 WKJP74
Engine: EZH-5.7L V8 HEMI MDS VVT ENGINE (Ser #6125010203)
Transmission: DGQ-5-SPD AUTOMATIC 545RFE TRANSMISS (Ser #:J155020129)
Plant: JEFFERSON NORTH ASSEMBLY PLANT
MDH: 061111

Report#: SSV010961131
Open Date: 10/15/2010
Mileage: 1000
Warr Built Dt: 06/11/2010
Supplier RP:

Zone/Cd: 32-44781
Name: DANBURY CHRYSLER JEEP DODGE RA
Address: 100B FEDERAL ROAD
 DANBURY, CT 06810
Phone: 203 730-5737

Part Information

Part Number	Part Description	Quantity	Cost/Unit	Fail Cd	Retn Dt
** No Parts Information Available					

Labor Information

LOP	LOP Description	Cost	Fail Cd
08	ELECTRICAL	0.00	

Service Narrative Information

Customer Comment: FIRE STARTED IN HEADLINER - VEHICLE TOTALLED

Service Action: CONTACTED DEALER. VEHICLE HAS BEEN BOUGHT BACK. PAUL STATES HE WAS CONTACTED BY CHRYSLER ENGINEERING ABOUT SENDING ENGINEERS TO INSPECT. PAUL STATES IT HAS BEEN 2 WEEKS AND HAS NOT HEARD ANYTHING BACK. DEALER HAS RECIEVED ALL PAPER WORK FOR BUY BACK, BUT WAS CURIOUS IF ENGINEERING STILL WANTED TO LOOK AT VEHICLE. WILL FORWARD CASE FOR REVIEW. NEBC PERSONEL CAME & INSPECTED VEHICLE

Correction:

Field Engineer Analysis Report



Issue Number: WT6126R[REDACTED]
 Business Group: Quality Field Engineer
 Location: Dallas
 Issue Type: Non-Powertrain
 Category: Reliability
 Reported By: Richard Carlson
 Phone: +1 214 319 1263
 Created On: 07/31/2012

Images: 1



Sun visor screw shorted the wiring on the passenger side



2012 WK
 VIN CC [REDACTED]
 Miles 1678

Fam	VIN	Mileage	MDH	Dealer	Eng	Tran	Part Retn
WK	CC [REDACTED]	1678	032908	43290	EZH 6076 2103 83	DG1 J075 2101 83	

CONCERN #1
Customer Concern:

The customer stated that the vanity mirror on the passenger side doesnt work.

Root Cause:

The right side vanity mirror mounting screw shorted the wiring.

P/N: 1TH79HL1AA
 LOP: 23204509
 Cost of repair: \$1374.00
 Keywords: PlantProcess

Field Engineer Analysis Report



CPA audit level: S100

Repair Action:

The headliner and visor were replaced.

Details: The customer stated that the vanity mirror on the passenger side doesnt work. And he saw smoke coming out of the headliner. The technician found that the one of the vanity mirror screws shorted the wiring to the mirror causing the wiring to melt. The headliner and visor were replaced.

TSB Group: 23

Repair Successful: Y

Issue Number: WT6126R0 [REDACTED]
Business Group: Quality Field Engineer
Location: Dallas
Issue Type: Non-Powertrain
Category: Reliability
Reported By: Richard Carlson
Phone: +1 214 319 1263
Created On: 07/31/2012

Images: 1

<u>Fam</u>	<u>VIN</u>	<u>Mileage</u>	<u>MDH</u>	<u>Dealer</u>	<u>Eng</u>	<u>Tran</u>	<u>Part Retn</u>
WK	CC [REDACTED]	1678	032908	43290	EZH 6076 2103 83	DG1 J075 2101 83	

QNA - Quality Narrative Analyzer Detail Report Digital Imaging Pre-Authorization Report#: D815274

VIN PLATE IMAGE



Field Engineer Analysis Report

QNA - Quality Narrative Analyzer Detail Report Digital Imaging Pre-Authorization Report#: D815274

Vehicle Information

Repair Information

Dealer Information

VIN: 1J4RS4GG1BC [REDACTED]

Model Year: 2011

Make/Model: JEEP

GRAND CHEROKEE LAREDO 4X2

WKTH74

Engine: ERB-3.6L V6 FFV 24V VVT ENGINE (Ser #:1127110296)

Transmission: DGJ-5-SPEED AUTO W5A580 TRANSMISSION (Ser #:J109160230)

Plant: JEFFERSON NORTH ASSEMBLY PLANT

MDH: 051322

Report#: D815274

Open Date: 09/13/2013

Mileage: 22962

Warr Built Dt: 05/13/2011

Zone/Cd: 66-45148

Name: JACKSONVILLE CHRYSLER JEEP DOD

Address: 11101 NURSERY FIELDS DRIVE

JACKSONVILLEFL32256, FL 32256

Phone: 904 493-0000

Service Narrative Information

Repair Issue: SHORT IN DRIVER SUN VISOR WIRING FOR VANITY MIRROR. CAUSING SHORT AND BURNING VISOR AND HEADLINER

Service Action: REPLACE HEAD LINER AND VISOR

Claim Type: Trim

QNA - Quality Narrative Analyzer Detail Report Digital Imaging Pre-Authorization Report#: D805595

VIN PLATE IMAGE



Field Engineer Analysis Report

QNA - Quality Narrative Analyzer Detail Report Digital Imaging Pre-Authorization Report#: D805595

Vehicle Information

Repair Information

Dealer Information

VIN: 1C4RJFAG5CC [REDACTED]

Report#: D805595

Zone/Cd: 35-60424

Model Year: 2012

Open Date: 08/28/2013

Name: KREBS CHRYSLER JEEP DODGE

Make/Model: CHRYSLER

Mileage: 22788

Address: 100 KREBS DR

GRAND CHEROKEE LAREDO 4X4

Warr Built Dt: 06/01/2012

GIBSONIAPA150449673, PA 150449673

WKJH74

Phone: 724 444-8000

Engine: ERB-3.6L V6 FFV 24V VVT ENGINE (Ser #6140210782)

Transmission: DGJ-5-SPEED AUTO W5A580 TRANSMISSION (Ser #:J149270289)

Plant: JEFFERSON NORTH ASSEMBLY PLANT

MDH: 060118

Service Narrative Information

Repair Issue: THERMAL EVENT, HEADLINER BURNED. CUSTOMER SAW FLAMES.

Service Action: ELECTRICAL CONCERN. CONFERRING WITH DM. (UPDATING CLAIM AS AVAIL) PROPOSE=REMOVE AND REPL HEADLINER AND LEFT VISOR. ELECTRICAL REMEDY IS A NON-DI ISSUE AND WILL PURSUE. THIS SEGMENT PNO(S) 1UX69HDAAA, 1LS25HDAAD LOP 2320 4509

Claim Type: Trim

QNA - Quality Narrative Analyzer Detail Report Digital Imaging Pre-Authorization Report#: D795131

VIN PLATE IMAGE



Field Engineer Analysis Report

QNA - Quality Narrative Analyzer Detail Report Digital Imaging Pre-Authorization Report#: D795131

Vehicle Information

Repair Information

Dealer Information

VIN: 1C4RJFBT6CC [REDACTED]

Report#: D795131

Zone/Cd: 42-44890

Model Year: 2012

Open Date: 08/12/2013

Name: PROGRESSIVE CHRYSLER JEEP DODG

Make/Model: CHRYSLER

Mileage: 24910

Address: 7966 HILLS AND DALES RD NE

GRAND CHEROKEE LIMITED 4X4

Warr Built Dt: 03/17/2012

MASSILLONOH446465241, OH 446465241

WKJP74

Phone: 330 833-8584

Engine: EZH-5.7L V8 HEMI MDS VVT ENGINE (Ser #6066210389)

Transmission: DG1-6-SPD AUTOMATIC 65RFE TRANSMISSI (Ser #:J053210785)

Plant: JEFFERSON NORTH ASSEMBLY PLANT

MDH: 031701

Service Narrative Information

Repair Issue:CUSTOMER STATED THAT SMOKE WAS COMING FROM THE LEFT FRONT OF THE HEADLINER

Service Action:WIRING HARNESS RUBBED THROUGH ON A SHARP EDGE OF THE ROOF AND MELTED WIRES AND BURNT THE DEADLINER. NEED TO REPLACE THE HEADLINER ASSY 23204509 3.0 PART#1TH79HL1AA

Claim Type:Trim

QNA - Quality Narrative Analyzer Detail Report Digital Imaging Pre-Authorization Report#: D775078

VIN PLATE IMAGE



QNA - Quality Narrative Analyzer Detail Report Digital Imaging Pre-Authorization Report#: D775078

Vehicle Information

Repair Information

Dealer Information

VIN: 1C4RJFBGXCC [REDACTED]

Report#: D775078

Zone/Cd: 74-44947

Model Year: 2012

Open Date: 07/09/2013

Name: JAY MALONE MOTORS

Make/Model: CHRYSLER

Mileage: 34587

Address: 1165 HIGHWAY 7 WEST

GRAND CHEROKEE LIMITED 4X4

Warr Built Dt: 02/11/2012

HUTCHINSONMN55350, MN 55350

WKJP74

Phone: 320 587-4748

Engine: ERB-3.6L V6 FFV 24V VVT ENGINE (Ser #6034210597)

Transmission: DGJ-5-SPEED AUTO W5A580 TRANSMISSION (Ser #:J039260217)

Plant: JEFFERSON NORTH ASSEMBLY PLANT

MDH: 021122

Service Narrative Information

Repair Issue:Trim

Service Action:CUSTOMER STATES THAT FRONT DOME LAMPS WONT TURN ON WHEN PUSHING THEM ON

Claim Type:PERFORMED DIAGNOSTIC AND FOUND THAT DRIVERS SIDE VISOR WIRING IS MELTED ALSO WIRING TO THE VISOR IS MELTED NEED TO REPLACE VISOR AND NEED TO REPLACE WIRING IN HEADLINER. ONLY WAY TO GET WIRING FOR HEADLINER IS TO REPLACE THE HEADLINER HEAD LINER PART# 1TH79HDAAA PRICE 1094.80 AND LOP 23204509 3.0 VISOR PART A# 1LS25HDAAD PRICE 108.85 LOP 23207503 DIAGNOSTIC TECHS DIAGNOSTIC FOUND LIGHTS WOULD NOT COME ON WHEN TURNED ON THEY WITH WITH THE DOORS FOUND NO POWER AT THE CONNECTOR FOR THE OVERHEAD CONSOLE REMOVED CLUSTER AND TESTED POWER FEED COMING OUT AND IT WAS SHORTED TO GROUND TRACED WIRING TO A SHORT IN HEADLINER THERE IS NO DIAGNOSTIC WORK SHEET FOR THIS WE WILL RA IT 1485.77 IT WILL NOT LET ME CHANGE ACTUAL COST

QNA - Quality Narrative Analyzer Detail Report Digital Imaging Pre-Authorization Report#: D772899

VIN PLATE IMAGE



QNA - Quality Narrative Analyzer Detail Report Digital Imaging Pre-Authorization Report#: D772899

Vehicle Information

Repair Information

Dealer Information

VIN: 1J4RR4GG8BC [REDACTED]

Report#: D772899

Zone/Cd: 35-65561

Model Year: 2011

Open Date: 07/03/2013

Name: HUMES CHRYSLER JEEP DODGE

Make/Model: JEEP

Mileage: 24049

Address: 1010 ROUTE 19 NORTH

GRAND CHEROKEE LAREDO 4X4

Warr Built Dt: 01/07/2011

WATERFORDPA16441, PA 16441

WKJH74

Phone: 814 796-2666

Engine: ERB-3.6L V6 FFV 24V VVT ENGINE (Ser #:1307010086)

Transmission: DGJ-5-SPEED AUTO W5A580 TRANSMISSION (Ser #:J004160719)

Plant: JEFFERSON NORTH ASSEMBLY PLANT

MDH: 010700

Service Narrative Information

Repair Issue:BURN HOLE ON HEADLINER BY L/S VISOR. DUE TO SHORT FROM VISOR(SCREW THROUGH WIRING)

Service Action:REPLACE HEADLINER PN 1UX09HDAAA LOP 23204509

Claim Type:Trim

QNA - Quality Narrative Analyzer Detail Report Digital Imaging Pre-Authorization Report#: D748241

VIN PLATE IMAGE



Field Engineer Analysis Report

QNA - Quality Narrative Analyzer Detail Report Digital Imaging Pre-Authorization Report#: D748241

Vehicle Information

Repair Information

Dealer Information

VIN: 1J4RR4GG7BC [REDACTED]

Model Year: 2011

Make/Model: JEEP

GRAND CHEROKEE LAREDO 4X4

WKJH74

Engine: ERB-3.6L V6 FFV 24V VVT ENGINE (Ser #6263610510)

Transmission: DGJ-5-SPEED AUTO W5A580 TRANSMISSION (Ser #:J024160207)

Plant: JEFFERSON NORTH ASSEMBLY PLANT

MDH: 012723

Report#: D748241

Open Date: 05/22/2013

Mileage: 34443

Warr Built Dt: 01/27/2011

Zone/Cd: 35-66479

Name: BERGEY'S CHRYSLER JEEP DODGE

Address: 408 HARLEYSVILLE PIKE

SOUDERTONPA189642141, PA 189642141

Phone: 215 721-3490

215 721-3470

Service Narrative Information

Repair Issue:CUSTOMER WAS DRIVING VEHICLE LEFT FRONT CONVER OF HEADLINER AND SUNVISOR CAUGHT FIRE. FOUND WIRING FOR VANITY MIRROR RUBBED THROUGH ON ROOF PANEL. PLASTIC FROM VISOR DRIPPED AND BURNED SEAT BOTTOM COVER

Service Action:REPLACE HEADLINER, VISOR, GRAB HANDLE AND LEFT FRONT SEAT BOTTOM COVER. LOP'S 23204509, 23204005, 23207503. PART #'S 1TH73HDAAA, 1LS25HDAAD, 5108107AB, 1MZ82HDAAB, 1RV73HDAAD, 5LK71BD3AA

Claim Type:Trim

QNA - Quality Narrative Analyzer Detail Report Digital Imaging Pre-Authorization Report#: D693071

QNA - Quality Narrative Analyzer Detail Report Digital Imaging Pre-Authorization Report#: D693071

Vehicle Information

Repair Information

Dealer Information

VIN: 1C4RJFAG8CC [REDACTED]

Model Year: 2012

Make/Model: CHRYSLER

GRAND CHEROKEE LAREDO 4X4

WKJH74

Engine: ERB-3.6L V6 FFV 24V VVT ENGINE (Ser #6123221201)

Transmission: DGJ-5-SPEED AUTO W5A580 TRANSMISSION (Ser #:J128261457)

Plant: JEFFERSON NORTH ASSEMBLY PLANT

MDH: 051123

Report#: D693071

Open Date: 01/30/2013

Mileage: 665

Warr Built Dt: 05/11/2012

Zone/Cd: 74-66052

Name: LAGER'S OF MANKATO INC

Address: 307 RAINTREE RD

MANKATOMN56001, MN 56001

Phone: 507 388-2944

507 625-9150

Service Narrative Information

Repair Issue: CUSTOMER CAME IN WITH SMOKE FILLING THE CABIN OF THE VEHICLE. FOUND SEATS, CARPETING AND CHECKED ALL WIRING. PULLED DOWN HEAD LINER AND FOUND WIRES SHORT FROM SUN VISOR AND MELTED THE HEADLINER HARNESS.

Service Action: RECOMMEND REPLACING THE HEADLINER AND DRIVERS SUN VISOR. PART NUMBERS 1TH79HDAAA AND ILS25HDAAD. LABOR OPERATIONS 23-20-45-09, 23-20-45-63, 23-20-75-03, AND 23-20-45-00. I HAVE 2.0 HOURS DIAG INCLUDED AND ALSO 7 DAYS RENTAL DUE TO PARTS AVAILABILTY.

Claim Type: Trim

QNA - Quality Narrative Analyzer Detail Report Digital Imaging Pre-Authorization Report#: D657448

VIN PLATE IMAGE



Field Engineer Analysis Report

QNA - Quality Narrative Analyzer Detail Report Digital Imaging Pre-Authorization Report#: D657448

Vehicle Information

VIN: 1C4RDJDG2CC [REDACTED]
Model Year: 2012
Make/Model: CHRYSLER
WD75 STX 4X4
WDEH75
Engine: ERB-3.6L V6 FFV 24V VVT ENGINE (Ser #6265110342)
Transmission: DGJ-5-SPEED AUTO W5A580 TRANSMISSION (Ser #:J251161041)
Plant: JEFFERSON NORTH ASSEMBLY PLANT
MDH: 092813

Repair Information

Report#: D657448
Open Date: 11/05/2012
Mileage: 28700
Warr Built Dt: 09/28/2011

Dealer Information

Zone/Cd: 63-59156
Name: SOUTHLAND DODGE CHRYSLER JEEP,
Address: 6161 WEST PARK AVENUE
HOUMALA70364, LA 70364
Phone: 985 876-1817

Service Narrative Information

Repair Issue:SMOKE FROM ROOF, DOME LIGHTS AND PASS VISOR LIGHT QUIT WORKING. SCREW TROUGH WIRING HARNESS ON HEAD LINER (VISOR SCREW) BURNT HARNESS AND WIRE IN VISOR. WIRING HARNESS COMES ON HEADLINER.
Service Action:REPLAC THE HEADLINER AND PASS VISOR. PART# 1UG01HDA-AA 1024.80 1LS27HDA-AD 102.13 LABOR# 23204509 1.7 151.78
Claim Type:Trim

QNA - Quality Narrative Analyzer Detail Report Digital Imaging Pre-Authorization Report#: D656936 VIN PLATE IMAGE



QNA - Quality Narrative Analyzer Detail Report Digital Imaging Pre-Authorization Report#: D656936

Vehicle Information

Repair Information

Dealer Information

VIN: 1C4RJFAG7CC [REDACTED]

Report#: D656936

Zone/Cd: 32-62457

Model Year: 2012

Open Date: 11/02/2012

Name: CENTRAL AVE. CHRYSLER JEEP DOD

Make/Model: CHRYSLER

Mileage: 1900

Address: 1839 CENTRAL PARK AVENUE

GRAND CHEROKEE LAREDO 4X4

Warr Built Dt: 06/23/2012

YONKERSNY107102828, NY 107102828

WKJH74

Phone: 914 961-5400

Engine: ERB-3.6L V6 FFV 24V VVT ENGINE (Ser #6165210832)

Transmission: DGJ-5-SPEED AUTO W5A580 TRANSMISSION (Ser #:J172260016)

Plant: JEFFERSON NORTH ASSEMBLY PLANT

MDH: 062312

Service Narrative Information

Repair Issue:DRIVERS VISOR WIRING WAS FUSED AND MELTED CATCHING FIRE AND BURNED THROUGH HEADLINER

Service Action:REPLACE 2 FUSES..HEADLINER AND DRIVERS VISOR

Claim Type:Trim

QNA - Quality Narrative Analyzer Detail Report Digital Imaging Pre-Authorization Report#: D647894

VIN PLATE IMAGE



QNA - Quality Narrative Analyzer Detail Report Digital Imaging Pre-Authorization Report#: D647894

Vehicle Information

Repair Information

Dealer Information

VIN: 1C4RJEAGXCC [REDACTED]

Model Year: 2012

Make/Model: CHRYSLER

GRAND CHEROKEE LAREDO 4X2

WKTH74

Engine: ERB-3.6L V6 FFV 24V VVT ENGINE (Ser #6131220189)

Transmission: DGJ-5-SPEED AUTO W5A580 TRANSMISSION (Ser #:J136260179)

Plant: JEFFERSON NORTH ASSEMBLY PLANT

MDH: 051813

Report#: D647894

Open Date: 10/16/2012

Mileage: 2594

Warr Built Dt: 05/18/2012

Zone/Cd: 66-45426

Name: ARRIGO DODGE CHRYSLER JEEP RAM

Address: 5901 MADISON AVE

TAMARACFL333216412, FL 333216412

Phone: 954 861-6200

Service Narrative Information

Repair Issue:THE FRONT PASSENGER SUNVISOR ASSLY HAD INTERNAL SHORT AND CAUGHT FIRE ON THE VISOR AND HEADLINER.

Service Action:REPLACE THE HEADLINER AND FRONT PASSENGER SUNVISOR ASSLY

Claim Type:Trim

QNA - Quality Narrative Analyzer Detail Report Digital Imaging Pre-Authorization Report#: D621795

VIN PLATE IMAGE

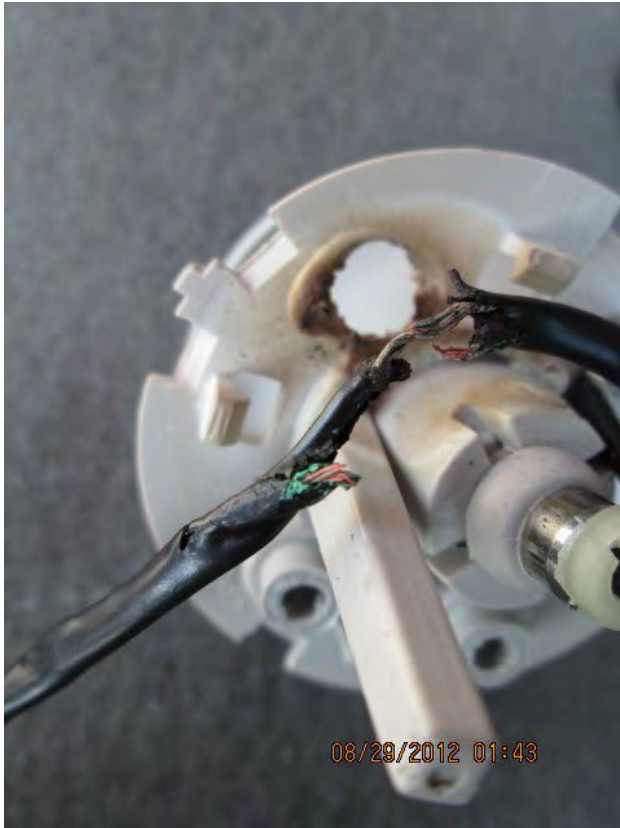

QNA - Quality Narrative Analyzer Detail Report Digital Imaging Pre-Authorization Report#: D621795

Vehicle Information

Repair Information

Dealer Information

VIN: 1J4RR4GT6BC [REDACTED]

Model Year: 2011

Make/Model: JEEP

GRAND CHEROKEE LAREDO 4X4

WKJH74

Engine: EZH-5.7L V8 HEMI MDS VVT ENGINE (Ser #6300010447)

Transmission: DGQ-5-SPD AUTOMATIC 545RFE TRANSMISS (Ser #:J302010771)

Plant: JEFFERSON NORTH ASSEMBLY PLANT

MDH: 110620

Report#: D621795

Open Date: 08/29/2012

Mileage: 23786

Warr Built Dt: 11/06/2010

Zone/Cd: 74-68116

Name: PARKS INC

Address: 11987 SW US HWY 54
AUGUSTAKS67010, KS 67010

Phone: 316 775-6366

316 775-4390

Service Narrative Information

Repair Issue: C/S THERE WAS SMOKE COMING FROM THE DRIVERS SIDE SUN VISOR AREA

Service Action: REPLACE HEADLINER DUE TO WIRES RUBBING ON BOLTS FOR BOTH SUN VISORS-HARNESSE NEEDED IS PART OF HEADLINER

Claim Type: Trim

QNA - Quality Narrative Analyzer Detail Report Digital Imaging Pre-Authorization Report#: D611078

VIN PLATE IMAGE



QNA - Quality Narrative Analyzer Detail Report Digital Imaging Pre-Authorization Report#: D611078

Vehicle Information

Repair Information

Dealer Information

VIN: 1C4RJFCG2CC [REDACTED]

Report#: D611078

Zone/Cd: 51-65062

Model Year: 2012

Open Date: 08/09/2012

Name: PALMEN MOTORS INC

Make/Model: CHRYSLER

Mileage: 1385

Address: 5431-75TH STREET

GRAND CHEROKEE OVERLAND 4X4

Warr Built Dt: 05/31/2012

KENOSHAWI531423601, WI 531423601

WKJS74

Phone: 262 697-3100

Engine: ERB-3.6L V6 FFV 24V VVT ENGINE (Ser #6127210821)

Transmission: DGJ-5-SPEED AUTO W5A580 TRANSMISSION (Ser #:J147260681)

Plant: JEFFERSON NORTH ASSEMBLY PLANT

MDH: 053120

Service Narrative Information

Repair Issue: ELECTRIC SHORT IN DRIVERS SUNVISOR CAUSING ELECTRICAL FIRE DAMAGED HEADLINER

Service Action: REPLACE HEADLINER LOP 23204509/23204563/85333333.PART#1TH79HDAAA \$1,027.60

Claim Type: Trim

QNA - Quality Narrative Analyzer Detail Report Digital Imaging Pre-Authorization Report#: D604558

VIN PLATE IMAGE



QNA - Quality Narrative Analyzer Detail Report Digital Imaging Pre-Authorization Report#: D604558

Vehicle Information

Repair Information

Dealer Information

VIN: 1C4RJFAG7CC [REDACTED]
Model Year: 2012
Make/Model: CHRYSLER
GRAND CHEROKEE LAREDO 4X4
WKJH74
Engine: ERB-3.6L V6 FFV 24V VVT ENGINE (Ser
#6348111475)
Transmission: DGJ-5-SPEED AUTO W5A580 TRANSMISSION
(Ser #:J355160288)
Plant: JEFFERSON NORTH ASSEMBLY PLANT
MDH: 122319

Report#: D604558
Open Date: 07/30/2012
Mileage: 220
Warr Built Dt: 12/23/2011

Zone/Cd: 42-58625
Name: MONROE DODGE-CHRY INC
Address: 15160 S MONROE ST
MONROEMI481613792, MI 481613792
Phone: 734 242-6370

Service Narrative Information

Repair Issue: WIRING HARNESS IN HEADLINER CAUGHT ON FIRE, AND BURNT OUT THE WIPER MOTOR, CLUSTER AND RIGHT AND LEFT SUN VISORS, NOTE: CLUSTER WILL NOT SHOW MILEAGE
Service Action: REPLACE CLUSTER, WIPER MOTOR, HEADLINER AND LEFT AND RIGHT SUN VISORS, 56046667AC 379.40/ 1LS25HDAAD 74.13/ 1LS27HDAAD 74.13 /6807954AA 136.43/ 1TH73HDAAA 880.60/ 08451001 .2/ 23207502 .2/ 23207503 .2/ 08528001 .4/ 23204509 1.7/ 85410000 3.5
Claim Type: Trim

QNA - Quality Narrative Analyzer Detail Report Digital Imaging Pre-Authorization Report#: D603670

VIN PLATE IMAGE



QNA - Quality Narrative Analyzer Detail Report Digital Imaging Pre-Authorization Report#: D603670

Vehicle Information

Repair Information

Dealer Information

VIN: 1J4RR4GG5BC [REDACTED]
Model Year: 2011
Make/Model: JEEP
GRAND CHEROKEE LAREDO 4X4
WKJH74
Engine: ERB-3.6L V6 FFV 24V VVT ENGINE (Ser
#:1291010932)
Transmission: DGJ-5-SPEED AUTO W5A580 TRANSMISSION
(Ser #:J322060154)
Plant: JEFFERSON NORTH ASSEMBLY PLANT
MDH: 120310

Report#: D603670
Open Date: 07/27/2012
Mileage: 18115
Warr Built Dt: 12/03/2010

Zone/Cd: 42-60558
Name: SUBURBAN CHRYSLER JEEP OF ANN
Address: 2060 W STADIUM BLVD
ANN ARBORMI481034558, MI 481034558
Phone: 734 662-3175

Service Narrative Information

Repair Issue: WIRING HARNESS ON HEADLINER SHORTED CAUSING WIRING BY THE SUNVISORS TO BURN. BURNED HOLES TO BOTH VISORS.
Service Action: REPLACE HEADLINER, BOTH SUNVISORS AND ATTACHING PARTS. USING LOP 23204509, 23207502, 23207503. WARRANTY LABOR RATE 85.90/HR. PART NUMBERS
1TH73HDAAA, 1LS25HDAAD, 1LS27HDAAD, 5108107AB, 5108116AB, 1MZ82HDAAB.
Claim Type: Trim

QNA - Quality Narrative Analyzer Detail Report Digital Imaging Pre-Authorization Report#: D598738

VIN PLATE IMAGE



**SHORT IN
WIRING TO PARK ASSIST
MODULE CAUGHT
FIRE AND BURNED
HEADLINER**

QNA - Quality Narrative Analyzer Detail Report Digital Imaging Pre-Authorization Report#: D598738

Vehicle Information

VIN: 1D4RE4GG1BC [REDACTED]
Model Year: 2011
Make/Model: DODGE
WD75 STX 4X4
WDEH75
Engine: ERB-3.6L V6 FFV 24V VVT ENGINE (Ser
#6121110150)
Transmission: DGJ-5-SPEED AUTO W5A580 TRANSMISSION
(Ser #:J125160727)
Plant: JEFFERSON NORTH ASSEMBLY PLANT
MDH: 051021

Repair Information

Report#: D598738
Open Date: 07/18/2012
Mileage: 11102
Warr Built Dt: 05/10/2011

Dealer Information

Zone/Cd: 42-60175
Name: ST. CLAIR CHRYSLER JEEP DODGE
Address: 1250 S CARNEY DR
SAINT CLAIRMI480795224, MI 480795224
Phone: 810 329-2282
810 329-2100

Service Narrative Information

Repair Issue:NECESSARY TO REPLACE THE TIPM, PARK ASSIST MODULE, HEADLINER, OVERHEAD CONSOLE, DRIVER'S SIDE VISOR, AND COAT HOOKS. LOPS: 08890102 REPLACE TIPM 3 HRS \$24.99 08200501 REPLACE PARK ASSIST MODULE .2 HOURS \$16.66 23204509 REPLACE HEADLINER 1.7 HRS \$141.61 23140201 REPLACE OVERHEAD CONSOLE .3 HRS \$24.99 23100701 REPLACE COAT HOOK .2 HRS \$16.66 23207503 REPLACE LEFT SUN VISOR .2 HRS \$16.66 PARTS: 4692316AI TIPM \$506.80 56054147AG PARK ASSIST MODULE \$85.54 1UG01HDAAA HEADLINER \$994.00 1UC601DAAB OVERHEAD CONSOLE \$464.80 1MG26HDAAB COAT HOOKS \$7.28 1LS25HDAAD ILLUMINATED VISOR &74.13 RENTAL: CUSTOMER IN RENTAL FOR 19 DAYS @ \$35.00 EACH OR \$665.00 THE AREA MANAGER WAS INVOLVED IN THIS CLAIM THE WHOLE WAY. HE HAS A NOTE IN THE SYSTEM FOR THE EXTRA DAYS OF RENTAL.

Service Action:Trim

Claim Type:CUSTOMER STATED THAT THE SERVICE BACK UP MONITOR WARNING LIGHT WAS ON AND THE WIPERS WOULDN'T SHUT OFF. ALSO THE TURN SIGNALS WERE INOP. THE TECHNICIAN ORDERED A NEW TIPM DUE TO IT BEING SHORTED OUT. IT WAS ON BACKORDER. SERVICE MANAGER HAD TO PUT CUSTOMER IN A RENTAL DUE TO SAFETY ISSUES. WHEN TIPM CAME IN AND WAS PLUGGED IN, TECH FOUND THERE WAS A SHORT IN THE WIRING TO THE PARK ASSIST MODULE IN THE HEADLINER ALSO. WIRES BURNED AND CAUSED DAMAGE TO THE HEADLINER, OVERHEAD CONSOLE, COAT HOOKS, AND DRIVER'S SIDE ILLUMINATED VISOR.

QNA - Quality Narrative Analyzer Detail Report Digital Imaging Pre-Authorization Report#: D590031

VIN PLATE IMAGE



Field Engineer Analysis Report

QNA - Quality Narrative Analyzer Detail Report Digital Imaging Pre-Authorization Report#: D590031

Vehicle Information

Repair Information

Dealer Information

VIN: 1D4RE4GG8BC [REDACTED]

Report#: D590031

Zone/Cd: 42-42050

Model Year: 2011

Open Date: 06/28/2012

Name: GLENBROOK DODGE CHRYSLER JEEP

Make/Model: DODGE

Mileage: 22875

Address: 100 W COLISEUM BLVD

WD75 STX 4X4

Warr Built Dt: 03/23/2011

FORT WAYNE IN 468051006, IN 468051006

WDEH75

Phone: 260 484-1533

Engine: ERB-3.6L V6 FFV 24V VVT ENGINE (Ser #:1075110469)

Transmission: DGJ-5-SPEED AUTO W5A580 TRANSMISSION (Ser #:J077160555)

Plant: JEFFERSON NORTH ASSEMBLY PLANT

MDH: 032312

Service Narrative Information

Repair Issue: C/S THER IS AN ELECTRICAL BURNING SMELL COMING FROM THE DRIVER'S SIDE VISOR AND THE CABIN IS FILLING WITH SMOKE.

Service Action: REPLACE BURNT HEADLINER AND WIRING AND BURNT VISORS.

Claim Type: Trim

QNA - Quality Narrative Analyzer Detail Report Digital Imaging Pre-Authorization Report#: D557885

VIN PLATE IMAGE



QNA - Quality Narrative Analyzer Detail Report Digital Imaging Pre-Authorization Report#: D557885

Vehicle Information

Repair Information

Dealer Information

VIN: 1J4RR5GT7BC [REDACTED]

Model Year: 2011

Make/Model: JEEP

GRAND CHEROKEE LIMITED 4X4

WKJP74

Engine: EZH-5.7L V8 HEMI MDS VVT ENGINE (Ser #6032110672)

Transmission: DGQ-5-SPD AUTOMATIC 545RFE TRANSMISS (Ser #:J052110488)

Plant: JEFFERSON NORTH ASSEMBLY PLANT

MDH: 031014

Report#: D557885

Open Date: 04/24/2012

Mileage: 10115

Warr Built Dt: 03/10/2011

Zone/Cd: 35-66320

Name: DARCARS CHRYSLER JEEP DODGE OF

Address: 5060 AUTH WAY

TEMPLE HILLSMD20746, MD 20746

Phone: 301 423-0853

301 423-5111

Service Narrative Information

Repair Issue: Trim

Service Action: THE DRIVER SIDE VISOR STARTED SMOKING BY LEFT CLIP, SCREW RAN THROUGH WIRING HARNESS CAUSING FIRE

Claim Type: REPLACE HEADLINER 23204509, 23204562, 23204563, PART# ITH80HL1AA

QNA - Quality Narrative Analyzer Detail Report Digital Imaging Pre-Authorization Report#: D552018

VIN PLATE IMAGE



QNA - Quality Narrative Analyzer Detail Report Digital Imaging Pre-Authorization Report#: D552018

Vehicle Information

Repair Information

Dealer Information

VIN: 1C4RJFCT8CC [REDACTED]

Model Year: 2012

Make/Model: CHRYSLER

GRAND CHEROKEE OVERLAND 4X4

WKJS74

Engine: EZH-5.7L V8 HEMI MDS VVT ENGINE (Ser #6337110430)

Transmission: DG1-6-SPD AUTOMATIC 65RFE TRANSMISSI (Ser #:J326111332)

Plant: JEFFERSON NORTH ASSEMBLY PLANT

MDH: 121000

Report#: D552018

Open Date: 04/10/2012

Mileage: 1618

Warr Built Dt: 12/10/2011

Zone/Cd: 32-66325

Name: BAYSIDE CHRYSLER DODGE JEEP RA

Address: 21219 NORTHERN BLVD

BAYSIDENY113613341, NY 113613341

Phone: 718 428-8777

718 229-8700

Service Narrative Information

Repair Issue:DRIVER SIDE SUN VISOR CAUGHT FIRE AND BURNED HEADLINER AND SUNROOF FRAME. CHRYSLER INSPECTOR CAME DOWN TO INSPECT VEHICLE

Service Action:REPLACED ALL BURNT PARTS LOP 23305701 2.1 FRAME 23305701 1.7 HEADLINER 23306602 0.2 SUNROOF EQUIP. 23121302 0.2 PASS VISOR 23121303 0.2 DRV VISOR 23306602 0.2 DEFLECTOR

Claim Type:Trim

QNA - Quality Narrative Analyzer Detail Report Digital Imaging Pre-Authorization Report#: D490039

VIN PLATE IMAGE

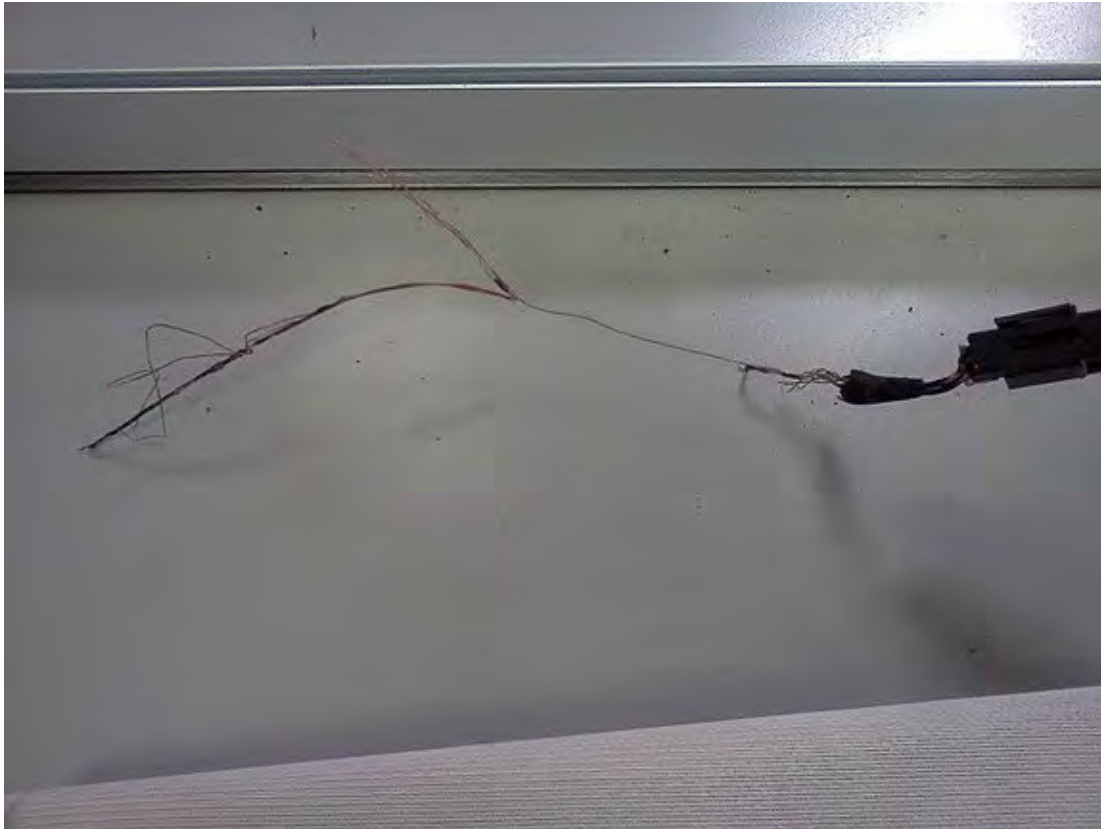

QNA - Quality Narrative Analyzer Detail Report Digital Imaging Pre-Authorization Report#: D490039

Vehicle Information

Repair Information

Dealer Information

VIN: 1D4SE5GT8BC [REDACTED]

Report#: D490039

Zone/Cd: 51-45016

Model Year: 2011

Open Date: 10/25/2011

Name: ANTIOCH CHRYSLER DODGE JEEP

Make/Model: DODGE

Mileage: 3565

Address: 105 ROUTE 173

WD75 LIMITED 4X4

Warr Built Dt: 04/29/2011

ANTIOCHIL60002, IL 60002

WDEP75

Phone: 847 395-0200

Engine: EZH-5.7L V8 HEMI MDS VVT ENGINE (Ser #6097110411)

Transmission: DGQ-5-SPD AUTOMATIC 545RFE TRANSMISS (Ser #:J116110018)

Plant: JEFFERSON NORTH ASSEMBLY PLANT

MDH: 042922

Service Narrative Information

Repair Issue:C/S THAT THERE IS SMOKE COMING FROM THE RIGHT CORNER OF THE WINDSHIELD. FOUND THAT THE PASSENGER SIDE VISOR WIRING SHORTED OUT AND CAUSED THE WIRING HARNESS IN THE HEADLINER TO

Service Action:REPLACE WIRING HARNESS THAT IS ATTACHED TO THE HEADLINER. REPLACE THE HEADLINER ALSO. PART #1UG08HDAAA(HEADLINER), PART #1LS27HDAAD (VISOR) LOP #23204509, 23204560, 23204562, 23204563, 23207503, 85410000

Claim Type:Trim

QNA - Quality Narrative Analyzer Detail Report Digital Imaging Pre-Authorization Report#: D383387

Vehicle Information

Repair Information

Dealer Information

VIN: 1J4RS4GG7BC [REDACTED]

Model Year: 2011

Make/Model: JEEP

GRAND CHEROKEE LAREDO 4X2

WKTH74

Engine: ERB-3.6L V6 FFV 24V VVT ENGINE (Ser
#:1190010382)

Transmission: DGJ-5-SPEED AUTO W5A580 TRANSMISSION
(Ser #:J215060155)

Plant: JEFFERSON NORTH ASSEMBLY PLANT

MDH: 081012

Report#: D383387

Open Date: 12/07/2010

Mileage: 556

Warr Built Dt: 08/10/2010

Zone/Cd: 66-60338

Name: AIRPORT CHRYSLER DODGE JEEP

Address: 5751 EAGLE VAIL DR

ORLANDOFL328221529, FL 328221529

Phone: 407 541-6200

Service Narrative Information

Repair Issue:Trim

Service Action:THE WIRING FOR THE SUNVISOR SHORTED CAUSING THE SUNVISOR AND THE HEADLINER TO MELT WHERE THE VISOR MEETS THE HEADLINER.

Claim Type:THE VISOR AND HEADLINER NEED TO BE REPLACED, PN#S 1TH79HDAAA, 1LS25HDAAD, 5108107AB, AND LABOR OPS 23-20-45-09, 23-20-45-60, 23-20-45-64

QNA - Quality Narrative Analyzer Detail Report Continuous Quality Insight Report#: 225556

Vehicle Information

Repair Information

Dealer Information

VIN: 1J4RR4GG4BC [REDACTED]

Model Year: 2011

Make/Model: JEEP

GRAND CHEROKEE LAREDO 4X4

WKJH74

Engine: ERB-3.6L V6 FFV 24V VVT ENGINE (Ser

Report#: 225556

Open Date: 12/20/2010

Mileage: 0

Warr Built Dt: 10/15/2010

Supplier RP:

Zone/Cd: ZZ-19028

Name: CHRYSLER CORPORATION

Address: 800 CHRYSLER DRIVE

AUBURN HILLS, MI 48326-2757

Phone:

Field Engineer Analysis Report

#:1277010817)

Transmission: DGJ-5-SPEED AUTO W5A580 TRANSMISSION

(Ser #:J280060825)

Plant: JEFFERSON NORTH ASSEMBLY PLANT

MDH: 101523

Part Information

Part Number	Part Description	Quantity	Cost/Unit	Fail Cd	Retn Dt
** No Parts Information Available					

Labor Information

LOP	LOP Description	Cost	Fail Cd
** No Labor Information Available			

CONTINUOUS QUALITY INSIGHT

Other>

Please describe the other trouble you experienced:

*

* Electrical System. I experienced an electrical problem two weeks ago, where my wipers wouldn't turn off. Furthermore the directionals, interior lights and horn wouldn't work.

Approximate mileage when trouble was first noticed was:

* 1500 - 3999 miles.

To the best of your recollection, the trouble was first noticed:

* 1 to 3 months after delivery.

Please describe conditions when this trouble occurs:

*

* normal

How often does this trouble occur?

* Trouble occurs regularly.

Field Engineer Analysis Report

Overview>

Have you taken the vehicle to a dealer to have your trouble corrected?

* Yes.

Would you recommend this vehicle to family or friends?

* No.

Overall, how satisfied are you with the quality of your new vehicle?

* Very dissatisfied.

Was the trouble resolved to your satisfaction?

* No.

Have you referred to the Owner's Manual, Warranty Manual, or other documents that came with your vehicle to answer questions about your vehicle?

* No.

Where did you take your vehicle to have your trouble checked out? (check all that apply)

* Took to the dealer I purchased my vehicle from.

* I dealer took five days to correct the so called problem.

If our team has any additional questions about your responses, would you accept further contact?

* Yes, by phone or e-mail.

Contact Me>

Based on the feedback you provided, would you like someone from Chrysler LLC to contact you about your Chrysler vehicle?

* Yes.

To better serve you, briefly describe the topic(s) you would like to discuss. Please provide us with a phone number you can be reached at during daytime hours. Thank you.

*

* 

Category Level

Selection

* Other.

Field Engineer Analysis Report

What Can We Do Better?>

What has Chrysler done right?

*

* I was satisfied with the vehicle until it burned up.

Feedback/Concerns:

*

* The day after I picked up the vehicle 12/15/10, I drove it to work and an electrical fire started above the passenger visor. The fire department responded and extinguished the fire, removed the scorched headliner and disconnected the battery. The vehicle was towed to the dealer. The dealer told me I need to contact my insurance co. I was not offered a loaner car or an explanation.

Welcome>

Are you the primary driver of this vehicle?

* Yes.

Please tell us how many miles are currently on your vehicle.

*

* 1700

PE13-027

CHRYSLER

10/7/2013

ENCLOSURE 6

VISOR LOP DETAIL 9 9 13

Headliner related LOPs

LOP	Description	Problem Code
8507201	Lamp, sun visor - Test and replace Left	11 broken or cracked
8507202	Lamp, sun visor - Test and replace Right	11 broken or cracked
0891KCE1	Wiring Visor Vanity/Map/Reading Lamps - Test and repair	1C connector loose or not attached, 1W wire cut by sharp edge, 2C connector broken/fractured, 2T terminals broken or fractured, 2W wires cut by moving mechanism , 3W wires cut by bolt/screw, 4W wires burned/damaged, 5W broken splice in harness, 58 internal defect, 7W harness not clipped or strapped
0891KCE1	Wiring Visor Vanity/Map/Reading Lamps - Test and repair	1C connector loose or not attached, 1W wire cut by sharp edge, 2C connector broken/fractured, 2T terminals broken or fractured, 2W wires cut by moving mechanism , 3W wires cut by bolt/screw, 4W wires burned/damaged, 5W broken splice in harness, 58 internal defect, 7W harness not clipped or strapped
0891KCK1	Wiring Visor Vanity/Map/Reading Lamps - Test and repair	1C connector loose or not attached, 1W wire cut by sharp edge, 2C connector broken/fractured, 2T terminals broken or fractured, 2W wires cut by moving mechanism , 3W wires cut by bolt/screw, 4W wires burned/damaged, 5W broken splice in harness, 58 internal defect, 7W harness not clipped or strapped
0891KCQ1	Wiring Visor Vanity/Map/Reading Lamps - Test and repair	1C connector loose or not attached, 1W wire cut by sharp edge, 2C connector broken/fractured, 2T terminals broken or fractured, 2W wires cut by moving mechanism , 3W wires cut by bolt/screw, 4W wires burned/damaged, 5W broken splice in harness, 58 internal defect, 7W harness not clipped or strapped
0891KCV1	Wiring Visor Vanity/Map/Reading Lamps - Test and repair	1C connector loose or not attached, 1W wire cut by sharp edge, 2C connector broken/fractured, 2T terminals broken or fractured, 2W wires cut by moving mechanism , 3W wires cut by bolt/screw, 4W wires burned/damaged, 5W broken splice in harness, 58 internal defect, 7W harness not clipped or strapped

Headliner related LOPs

0891PMK1	Wiring Overhead Console - Test and repair	1C connector loose or not attached, 1W wire cut by sharp edge, 2C connector broken/fractured, 2T terminals broken or fractured, 2W wires cut by moving mechanism , 3W wires cut by bolt/screw, 4W wires burned/damaged, 5W broken splice in harness, 58 internal defect, 7W harness not clipped or strapped
23204509	Headliner - Replace	X2 split, cut or torn, 1W wires cut by sharp edge, 14 short or open , 2W wires cut by moving mechanism, 3W wires cut by bolt/screw, 4W wires burned/damaged , 5W broken splice in harness, 69 discolored
23207502	Visor, sun - Replace Right	X2 split, cut or torn, , X6 terminal damaged, 11 broken or cracked, 2T terminal broken or cracked, 27 damaged, 48 grounded or shorted, 5T terminal pushed out14 short or open , 69 discolored
23207503	Visor, sun - Replace Left	X2 split, cut or torn, , X6 terminal damaged, 11 broken or cracked, 2T terminal broken or cracked, 27 damaged, 48 grounded or shorted, 5T terminal pushed out14 short or open , 69 discolored
23207402	Cover, sun visor bracket - Replace Right	X2 split, cut or torn, 11 broken or cracked, 27 damaged, 69 discolored
23207403	Cover, sun visor bracket - Replace Left	X2 split, cut or torn, 11 broken or cracked, 27 damaged, 69 discolored
23207702	Retainer, sun visor - Replace Clip/Receptacle/Retainer/Support-One or All	K4 loose, 06 bent, 11 broken or cracked, 51 improperly installed
23306352	Tube, sunroof drain Tube, Sunroof Drain - Replace/Repair	06 bent, 51 improperly installed, SE shortage part, 26 cut short, 27 damaged, 4X water leak, 51 improperly installed
23305702	Frame, sunroof - Replace Dual Pane Sunroof	11 Broken or cracked, 51 improperly installed, SE shortage part, 27 damaged, 51 improperly installed
23306503	Glass, sunroof - Replace Glass Rear - Dual Pane Sunroof	All fail codes

PE13-027

CHRYSLER

10/7/2013

ENCLOSURE 7

Service Installation Repair
Procedure

INSTALLATION

NOTE: Whether the sun visor was replaced or not, make sure the visor is aligned correctly and toe strapped to the overhead consoles mounting bracket before continuing.

NOTE: The following steps are to be performed on both driver and passenger sides; although it does not matter which side is first.

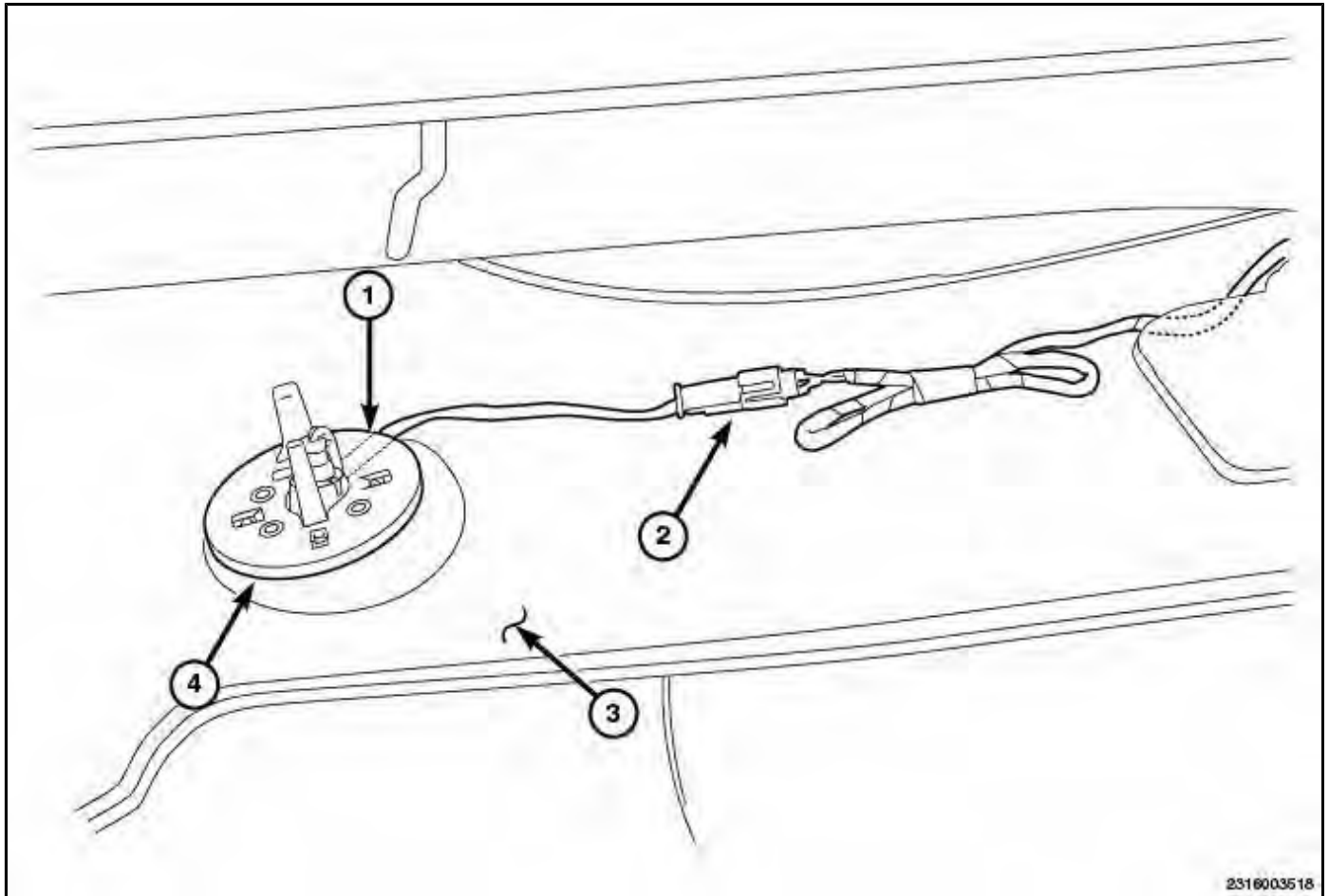

1. Position the white plastic 'top hat' clip (4) and place above the overhead trim hole.
2. Positioning the passenger side sun visor below the overhead trim panel, feed the visor pigtail wiring (2) through the trim panel hole and reconnect to the overhead harness, then seat the white 'top hat' clip (4) in position.
3. Make sure that the visor pigtail wiring is correctly routed through the wiring channel (1) of the white 'top hat' clip (4) and gather the excess wiring as far inboard as possible.
4. Pinch the white 'top hat' clip (4) and sun visor base together until they snap closed, sandwiching the overhead trim panel.

NOTE: This temporarily secures the rebuilt joint prior to installation of the sun visor screws into the roof header.

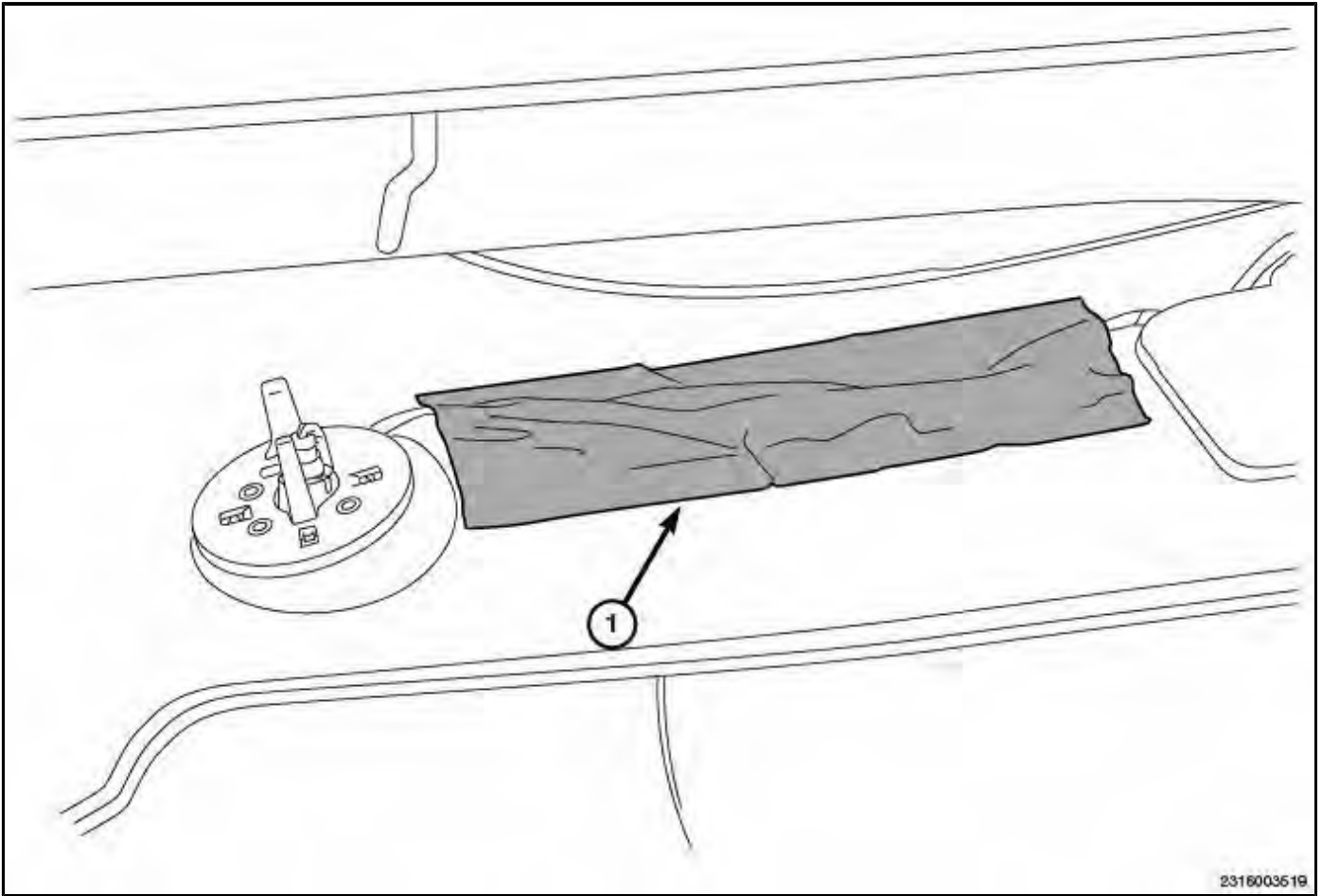

2316003519

5. Grab the excess wiring and tape (1) the gathered bundle down to the overhead trim panel as shown.

NOTE: Make sure that no wiring is near the visor fastener locations.

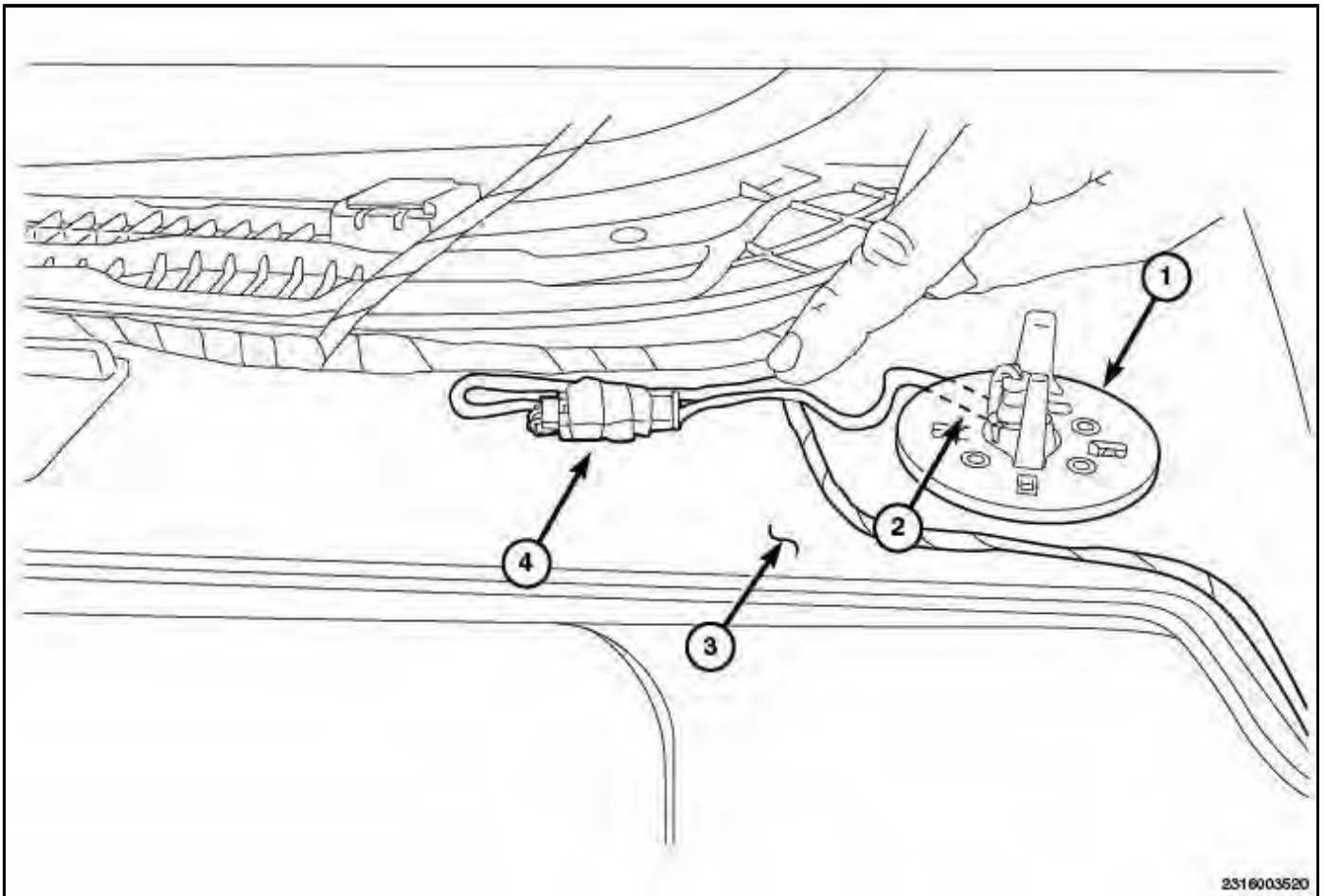

6. Moving to the drivers side, positioning the sun visor below the overhead trim panel feeding the visor pigtail wiring (4) through the headliner hole. Connect the electrical connection (4) to the overhead harness and locate the white 'top hat' clip (1) in position.
7. Make sure that the visor pigtail wiring is correctly routed through the wiring channel (2) of the white 'top hat' clip (1) and gather the excess wiring as far inboard as possible.
8. Pinch the white 'top hat' clip and sun visor base together until they snap closed, sandwiching the headliner (3).

NOTE: This temporarily secures the rebuilt joint prior to installation of the sun visor screws into the roof header.

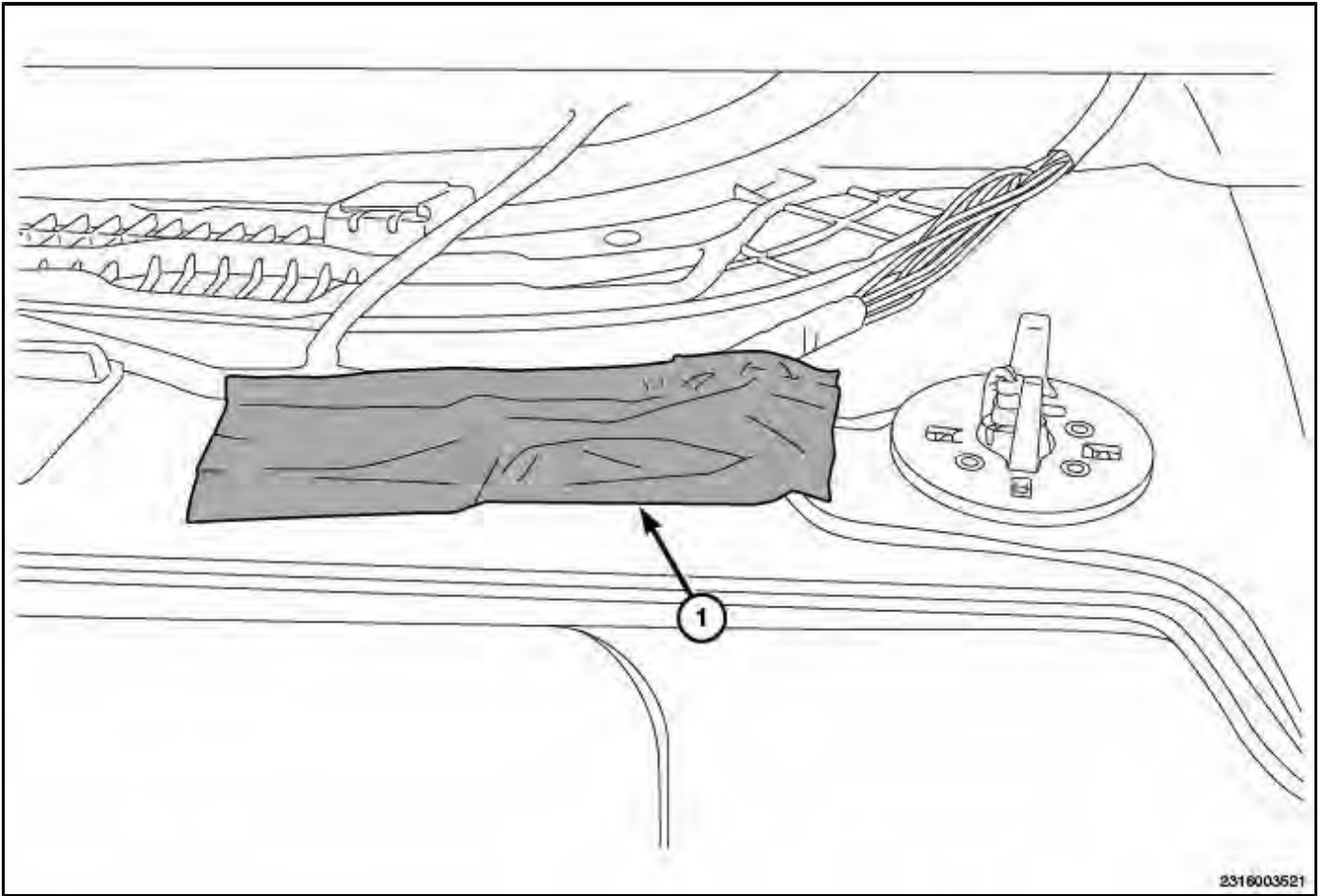

9. Grab the excess wiring and tape (1) the gathered bundle down to the overhead trim panel as shown

NOTE: Make sure that no wiring is near the visor fastener locations.

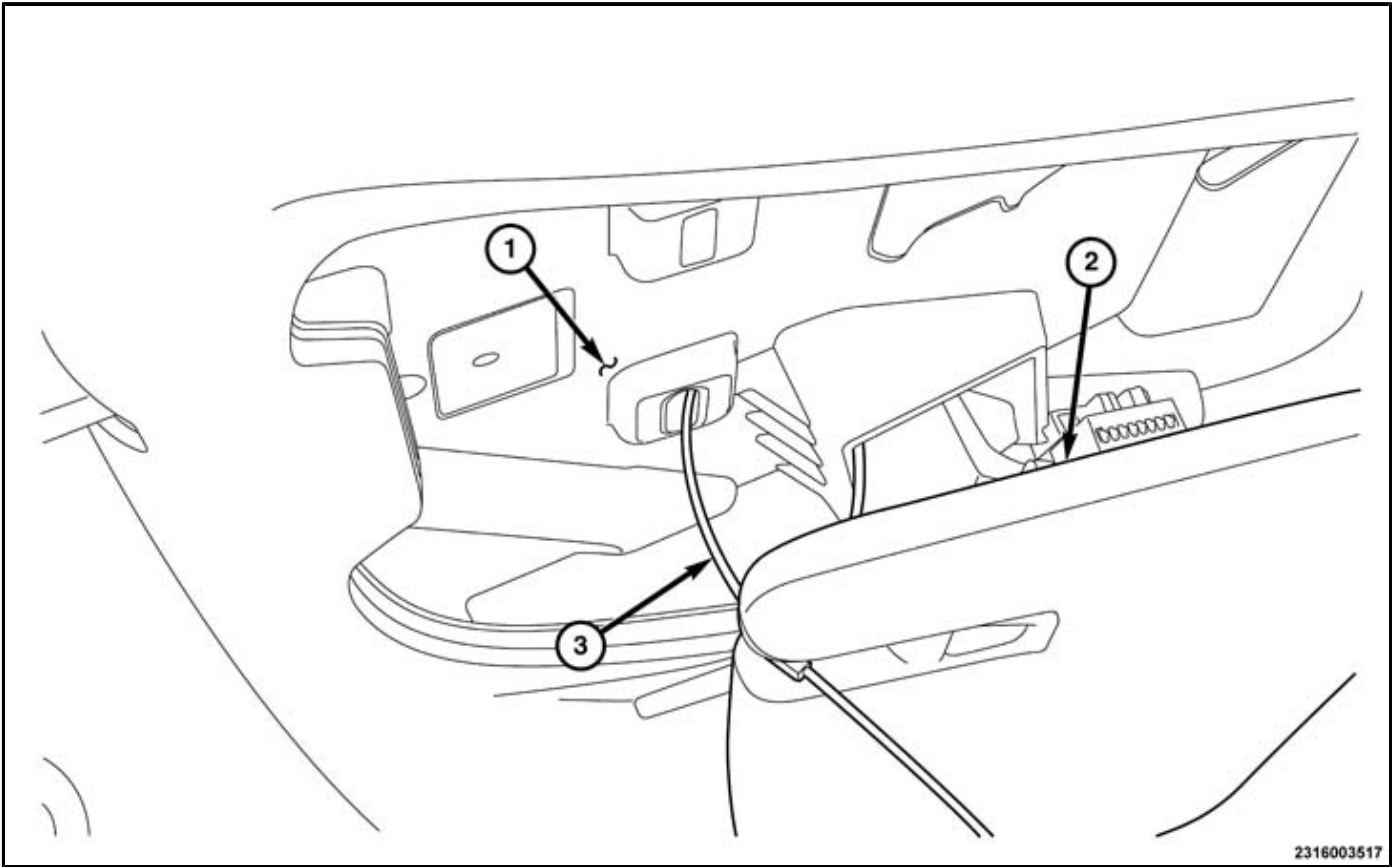

10. If necessary position the inboard sun visor support rod and install a tie strap (3) on both sun visors (2) to the overhead center console's roof mounted black console support bracket (1).
11. With one hand on the center of the headliner, raise the headliner assembly toward the roof and secure both the passenger side and driver side sun visor assemblies into the roof header.
12. Install the three sun visor fasteners into both assembled sun visor assemblies.

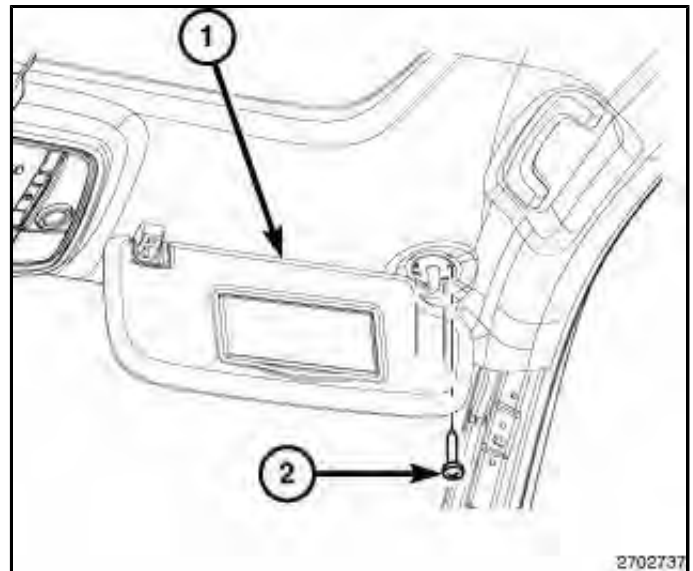

13. Install both sun visor screw covers (2).

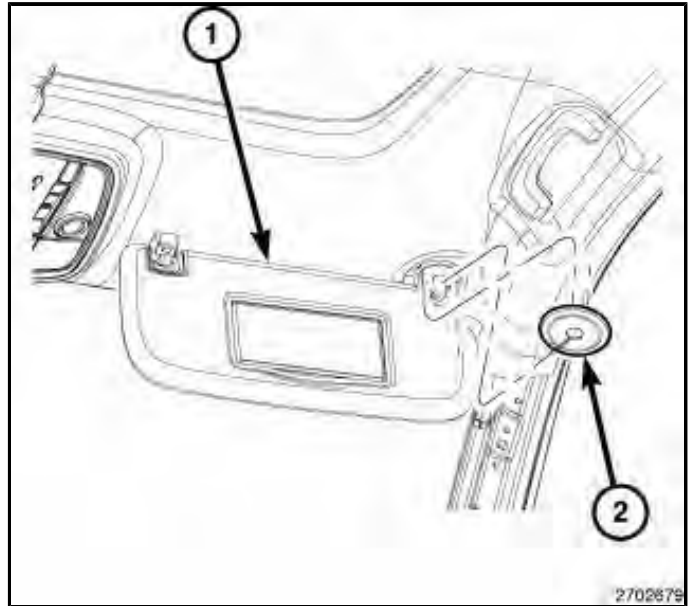

14. Passenger side first, position the inboard sun visor support clip (2) in place and install the fastener (3). Repeat for drivers side.

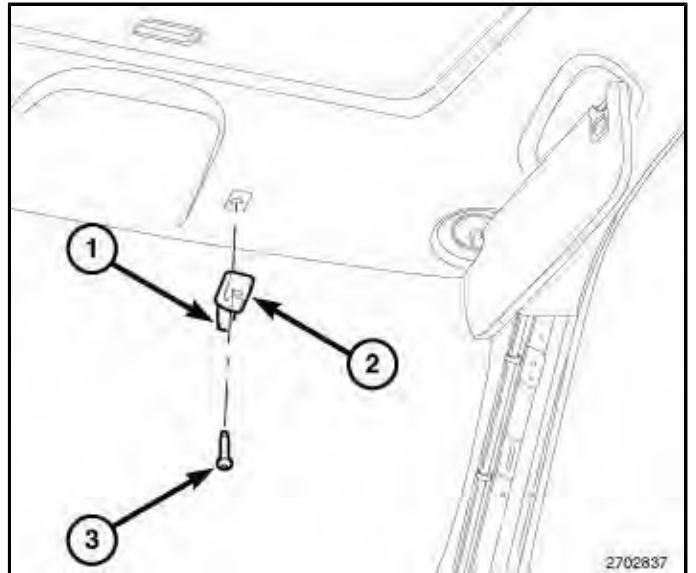

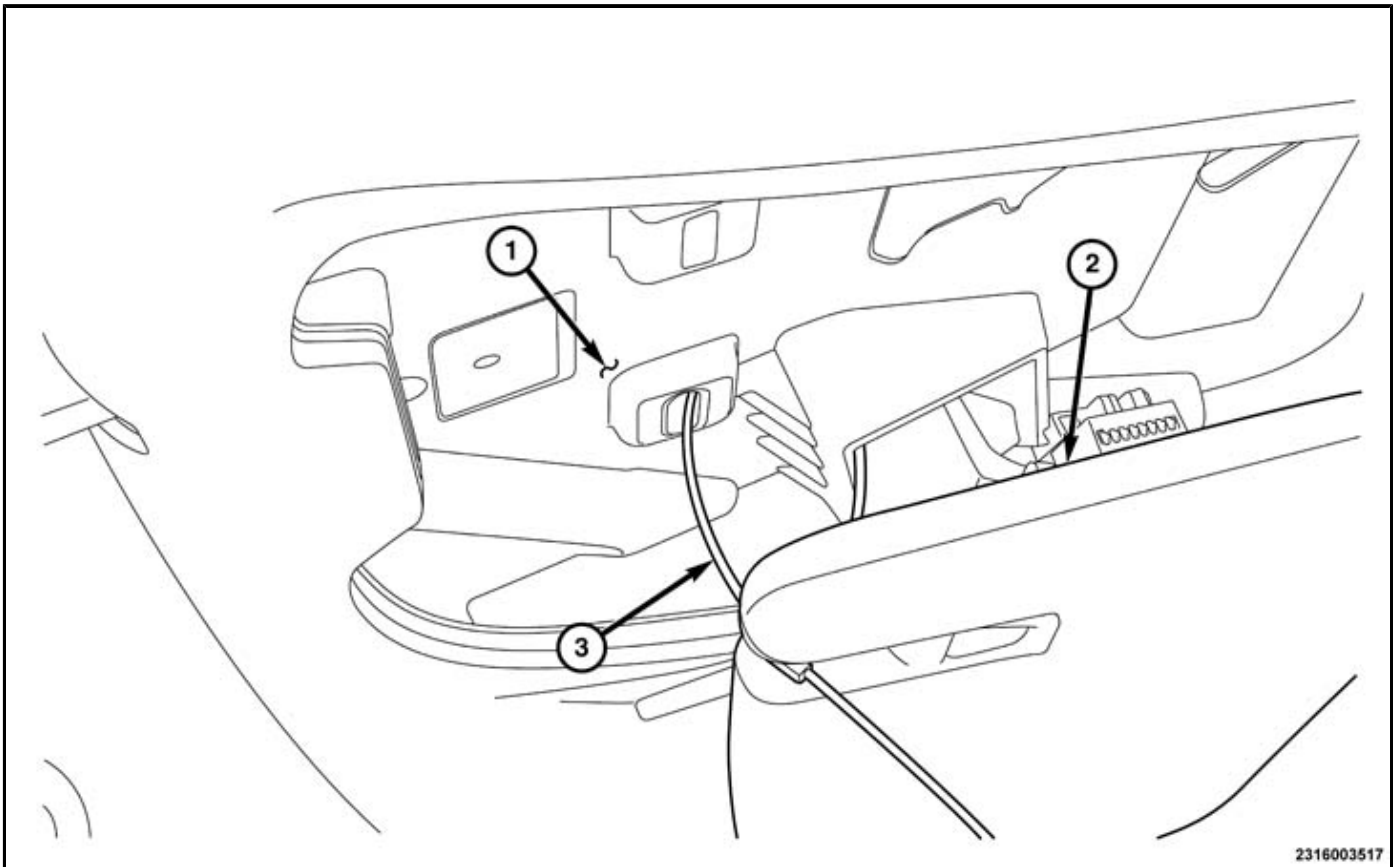

2316003517

15. Cut both tie straps (3) securing the sun visors to the overhead console support bracket (1) and discard.
16. Secure both sun visor rods into their appropriate inboard visor support clips.
17. Install the overhead console fastener.
18. Connect the overhead console electrical connections and install the overhead console. (Refer to 23 - Body/Interior/CONSOLE, Overhead/Installation)
19. Install front & rear grab handles on both sides. (Refer to 23 - Body/Interior/HANDLE, Grab/Installation)
20. Install the coat hooks, if equipped.
21. Install B-pillar upper & lower trim panels on both sides. (Refer to 23 - Body/Interior/PANEL, B-Pillar Trim/Installation)
22. Install A-pillar trim panels on both sides. (Refer to 23 - Body/Interior/PANEL, A-Pillar Trim/Installation)
23. Install the media system monitor if so equipped. (Refer to 08 - Electrical/8A - Audio and Video/MONITOR, Media System/Installation)
24. Connect the vehicle battery and verify the electrical functionality of both sun visors and overhead console.

PE13-027

CHRYSLER

10/7/2013

ENCLOSURE 7

Service Removal procedure
part 1

23 - Body/Interior/HEADLINER/Removal

REMOVAL

1. Remove the visors. (Refer to 23 - Body/Interior/VISOR/Removal)
2. Disconnect the front electrical connector (2) and separate the wire harness (1) from the A-pillar.

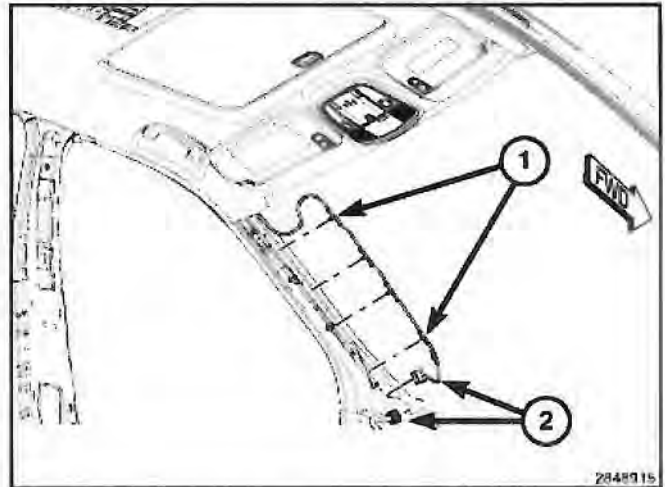

3. Remove the D-pillar trim panels. (Refer to 23 - Body/Interior/PANEL, D-Pillar Trim - Removal)
4. Disconnect the rear electrical connectors (1).
5. Remove the two rear push pin fasteners (2).

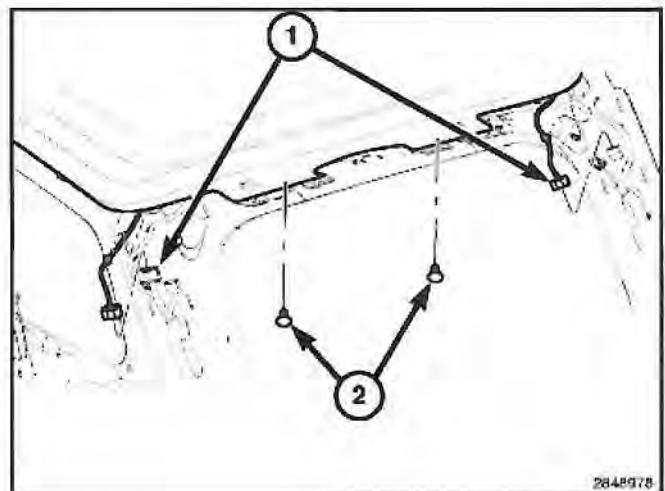

6. For vehicles with a sunroof, separate the hook and loop fasteners (2) around the outside of the sunroof opening.

CAUTION Be careful not to crease the headliner.

7. Remove the headliner through the liftgate opening.

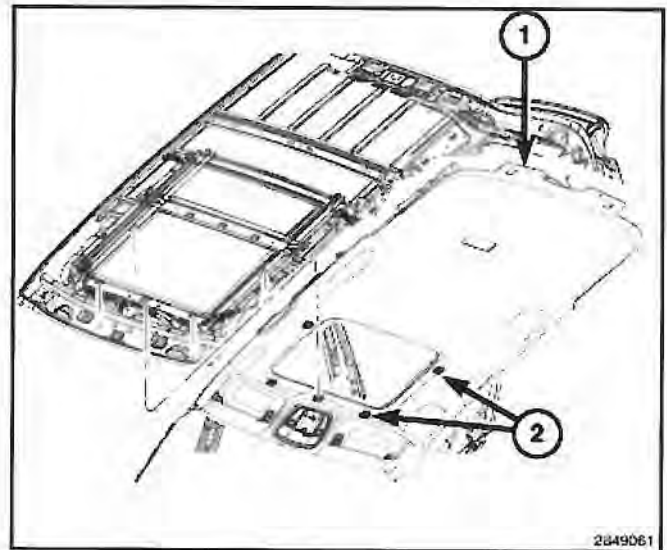

2649061

PE13-027

CHRYSLER

10/7/2013

ENCLOSURE 7

Service Removal procedure
part 2

REMOVAL

NOTE: This process is to be followed whether a sun visor is being replaced or not!

1. Disconnect and isolate the battery negative cable.
2. Remove the media system monitor, if equipped. (Refer to 08 - Electrical/8A - Audio and Video/MONITOR, Media System - Removal)
3. Remove 'A' Pillar trim panels on both sides. (Refer to 23 - Body/Interior/PANEL, A-Pillar Trim/Removal)
4. Remove 'B' pillar upper & lower trim panels on both sides. (Refer to 23 - Body/Interior/PANEL, B-Pillar Trim/Removal)
5. Remove the coat hooks, if equipped.
6. Remove front & rear grab handles on both sides. (Refer to 23 - Body/Interior/HANDLE, Grab/Removal)
7. Remove center overhead console fastener & drop console. (Refer to 23 - Body/Interior/CONSOLE, Overhead/Removal)
8. Remove both inboard sun visor fasteners and supports.

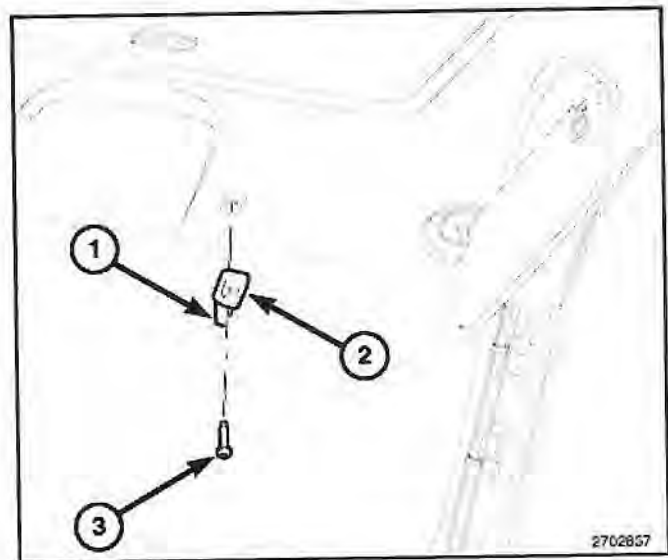

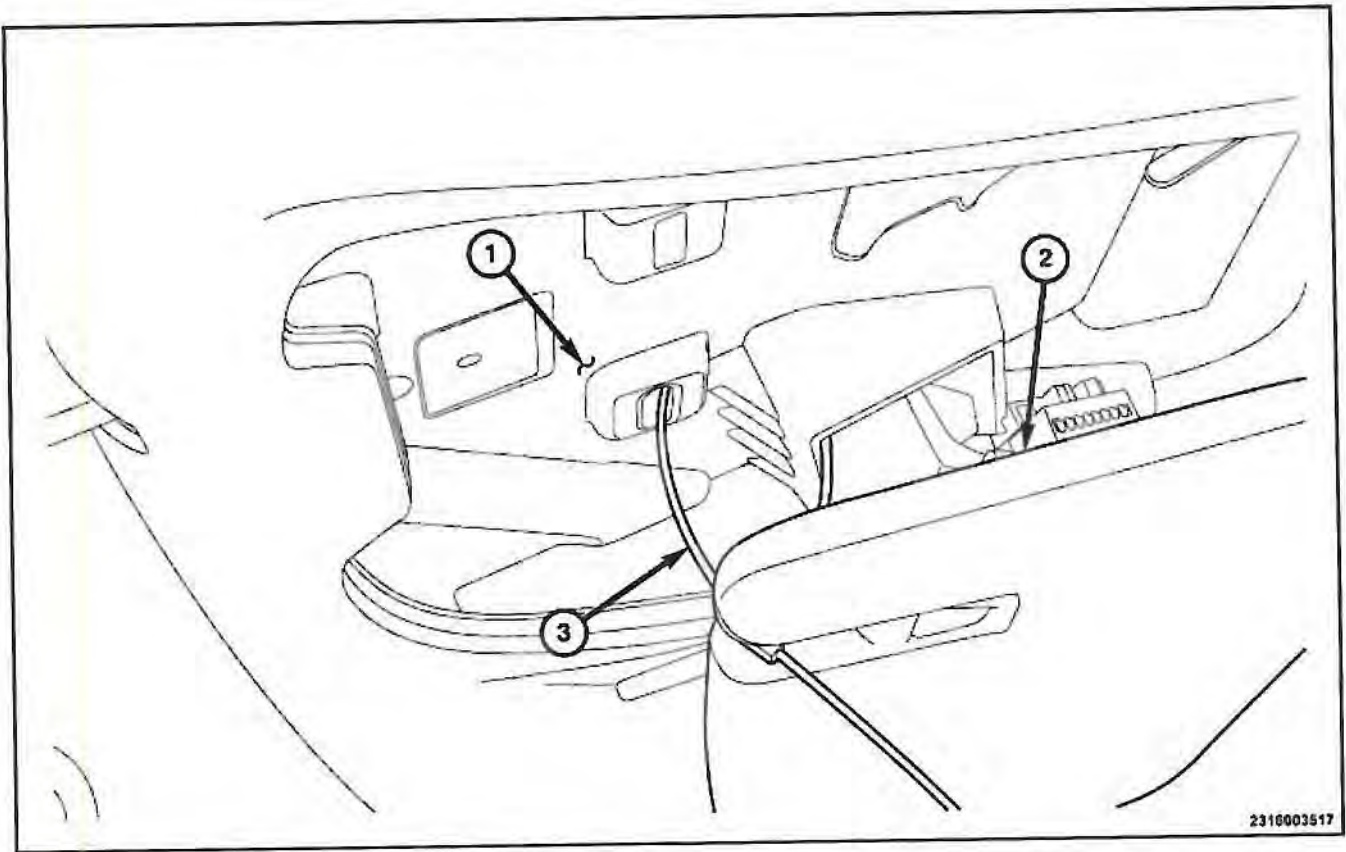

9. Extend both sun visors toward the center of vehicle.
10. Position the inboard sun visor support rod and install a tie strap (3) both sun visors (2) to the overhead center console's roof mounted black console support bracket (1).

NOTE: Visors should be rotated downward.

11. Remove visor screw covers (2).

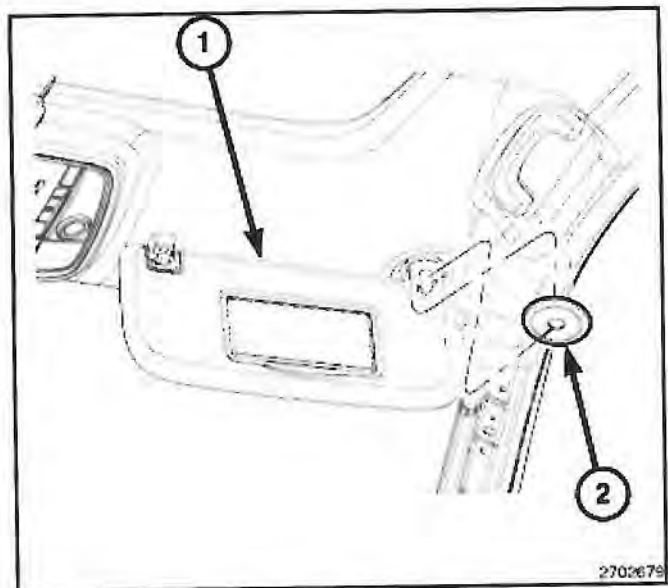

12. Remove all visor fasteners (2) from both sides.

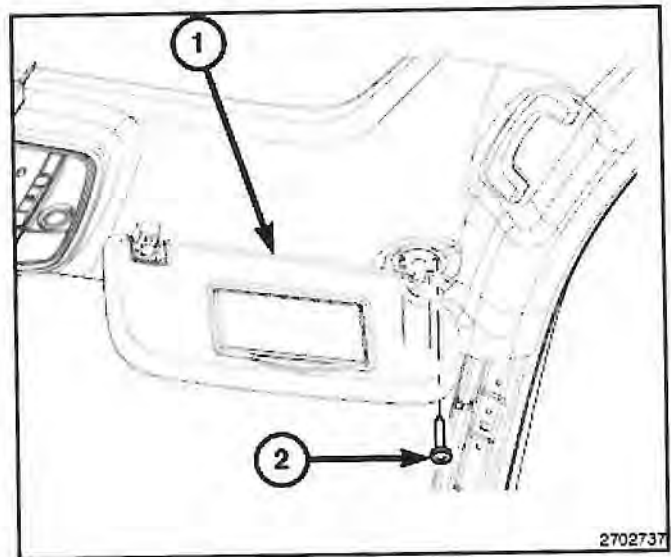

13. For vehicles with a sunroof, separate the hook and loop fasteners (2) around the outside of the sunroof opening.

CAUTION

Be careful not to crease the headliner.

14. Pull down the headliner.

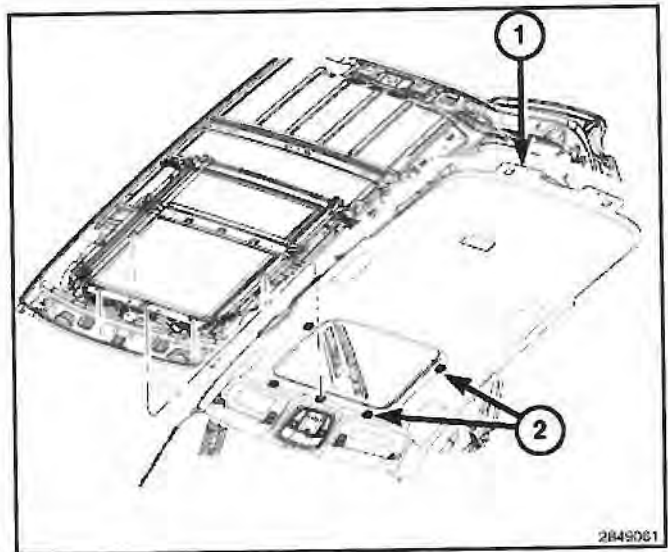

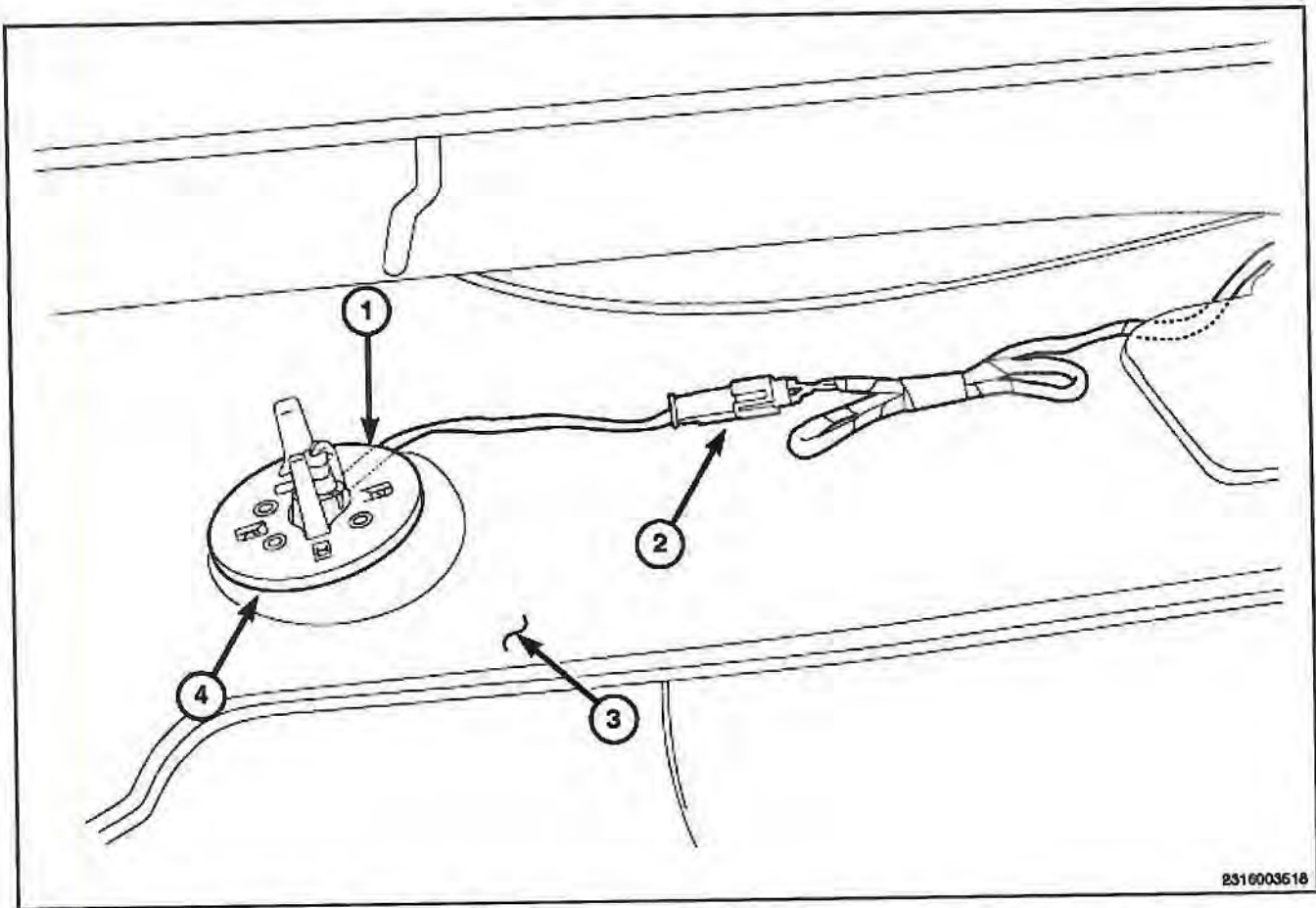

15. Remove the white colored 'top hat' clip (4) from the roof header carefully, it will need to be re-used (if the clip breaks a new one will be required for installation).

NOTE: Whether the sun visor was replaced or not, make sure the visor is aligned correctly and tie strapped to the overhead console's mounting bracket before continuing.

16. Disconnect the electrical connector (2) and remove the visor as necessary.

PE13-027

CHRYSLER

10/7/2013

ENCLOSURE 9

Visor Pigtail & Headliner
Change Public



W Program Visor Wiring

Short Term Implementation



Submitted to the Office of the Chief Counsel



Submitted to the Office of the Chief Counsel