

PE13-014

FORD

7/10/2013

APPENDIX D

E PAGE 16

F PAGE 168

F PAGE 173

I PAGE 196

J PAGE 198

K PAGE 206

L PAGE 212

O PAGE 226

PE13-014

FORD

7/10/2013

Appendix D

Subject - Legal Contacts

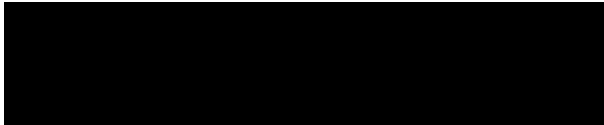

Case



General Info

Overview

Case Number	[Redacted]	Status	Active
Priority	[Redacted]	Owner	Tier 1 Inbound
Expected Resolution Date	[Redacted]	Status Reason	Active New
Input Channel	Phone		

Customer Info

Customer Name	[Redacted]	Caller Type	
Customer Delegate	[Redacted]	Use for Reply-To	
Phone	[Redacted]		
Relationship	[Redacted]		

RECEIVED
GENERAL CLERK
NOV 26 2012
OFFICE OF THE
GENERAL CLERK

Customer Scores

Loyalty Score		Defector Score	
CLP LTV Score		Dissat Score	
In-Market		ESP Score	
Likelihood to Service		Service Segments	

Dealer Info

Dealer Info

Dealer	Airport Marina Ford
Dealer Contact	
Portal Status	No New Message
FMCC Branch Code	

Vehicle Info

Vehicle Info

VIN	1FTSX20508E [Redacted]	Hours in Service	
------------	--	-------------------------	--

Converted Mileage		Mileage
Vehicle Modifications	No	Mileage Units
Engines Specification		Transmissions Specification
Number of Repairs		Days Out of Service

Vehicle Specification

Vehicle Specification Full Path  [2008 > FORD > F-SERIES SUPER DUTY > X20 - F250 4X2 SUPERCAB - SRW](#)

Model Year  [2008](#)

Make  [FORD](#)

Model / Vehicle Line  [F-SERIES SUPER DUTY](#)

Body Style  [X20 - F250 4X2 SUPERCAB - SR](#)
W

Case Classification

Classification

Responsible Team  [Tier 1 Inbound](#)

Case Classification Full Path  [Vehicle Concern > Legal > Alleged Accident > Not Portal](#)

Case Classification Level 1  [Vehicle Concern](#)

Case Classification Level 2  [Legal](#)

Case Classification Level 3  [Alleged Accident](#)

Case Classification Level 4  [Not Portal](#)

Classification

Initial Contact Target	Initial Contacted	No
Case Closure Target	Initial Contact Date	

Symptom Code

Symptom Code  [Comfort & Entertainment > Audio > Steering Wheel Control > Inoperative](#)

Level 1  [Comfort & Entertainment](#)

Level 2  [Audio](#)

Level 3  [Steering Wheel Control](#)

Level 4  [Inoperative](#)

Miscellaneous Info**Miscellaneous Info**

Master Case

Caller Authorization Code 0000112467

Stars ID

Tech Hotline No

Contract Info

ESP Contract #**Warranty Start Date**

Ford Credit Contract #

Form Letter Code

Non-Ford ESP No

Notes & Article**Notes**

 Title: Note created on 11/19/2012 03:36 PM by Michele Demara
Note created on 11/19/2012 3:36 PM by Michele Demara

Edited 11/19/2012 3:36 PM by Michele Demara

****cust said****

-----had an accident 2 weeks ago-----steering went out and hit a parked veh-----

****Accidents****

1. Date of the accident

2. What the customer is alleging the product defect is that caused Accident

-----Steering /////wheel just goes around no steering

3. If there were any injuries sustained

-----no

4. Location of the vehicle when the accident occurred

-----on a residential street los angles CA

5. Whether or not there was a police report filed.

-----no

6. If a police report was filed, what the findings were.

-----n/a

7. The police report number and the city or county in which the report was filed.

-----n/a

8. Whether or not the customer has filed a claim with their Insurance Company.

-----yes---cust only has liability

9. If a claim has been filed with the insurance company, what is the status of the claim.

-----will repair other veh

10. Whether or not the vehicle is repairable.

-----yes

11. Name and address of customer's attorney (only if the customer mentions they have sought one).

12. What the customer is seeking

-----wanted to see if any recalls and if he should check -----cust says cost to cost 3.000 just for parts-----looking for f/a for this repair to see if this was the cause of the problem

****dealer info****

-----Airport Marina Ford (05563)

5880 Centinela Ave.

Los Angeles, CA 90045

(877) 999-9546

****crc advised****

-----I will be sending this info to our Legas dept for review-----please allow 15 business days to receive a packet in the mail in regards to this issue-----

Article

Article

Admin Info

Admin Info

Created By  Michele Demara

Modified By  Michele Demara

Created On 11/19/2012 3:36 PM

Modified On 11/19/2012 3:36 PM

Begin Date 11/19/2012

Case Type

Title





Case Print Report

Case Number [REDACTED]

Case Opened Date 5/15/2013 1:43 PM

Case Closed Date 5/15/2013

Case Status Resolved

Case Last Modified 5/15/2013 1:44 PM

Responsible Team Tier 1 Inbound

Case Classification Vehicle Concern > Legal > Alleged Accident > Not Portal

FORD MOTOR COMPANY
RECEIVED
CLAIMS UNIT

MAY 16 2013

OFFICE OF THE,
GENERAL COUNSEL

Customer Name [REDACTED]

Customer Number [REDACTED]

HUMBLE [REDACTED]

Email [REDACTED]

Dealer [REDACTED]

VIN 1FTSW21R78E [REDACTED]

Year 2008

Make FORD

Model F-SERIES SUPER
DUTY

Body Style W21 - F250 4X4 CREWCAB - SRW

Symptom

Level 1

Level 2

Level 3

Level 4

Case Print Report

Case Number [REDACTED]

Agent Name	Note Last Modified
Kathy Aldridge	5/15/2013 1:44 PM

Case Print Report

Case Number [REDACTED]

Agent Name

Note Last Modified

1FTSW21R78E
CUST SAY:

-STEERING GEAR BOX WENT OUT WHILE CUST WAS DRIVING
-THE TIRES BUMPER AND FENDERS ARE MESSED UP

Accidents

1. Were any injuries sustained? YES

- Please provide the first and last name of all injured parties [REDACTED]

2. What are you seeking from Ford Motor Company? REPAIR COSTS FOR THE VEHICLE

3. What was the date of the accident? [REDACTED]

4. What product defect is alleged to have caused the accident? STEERING GEAR BOX

5. What is the City and State where the accident occurred? HOUSTON, TX

6. Was a police report filed? NO

7. If a police report was filed, what were the findings? N/A

8. What is the police report number and in what city and county was the report filed? N/A

9. Has the customer filed a claim with their Insurance Company? (Yes or No) YES

10. If a claim has been filed with the insurance company, what is the status of the claim? PENDING

11. Is the vehicle repairable? YES

12. What is the name and address of customer's attorney? (only if the customer mentions they have sought one) N/A

13. What mailing address would you like our Office of General Counsel to send your written response to? (You must document the full address in the case Notes)

[REDACTED]
[REDACTED]
[REDACTED]
HUMBLE, TX [REDACTED]

CRC ADVISED:

I will forward your information to Ford's Office of the General Counsel. You should receive a written response within 15 Days business days to your concern.

Case Print Report

Case Number



Server: AWS Prod
 Claims loaded through: 21-MAY-2013

STANDARD CLAIMS LIST

AWS Online Report

Run Date: 22-MAY-13

Note: All Costs are in US Dollars Server Name: AWS Prod Claims loaded through

VIN	AWS VL	WERS VL	MKT DER	BODY CAB	VER SERIES	DRIVE TYPE	PLANT CD	TRANS CD	ENG COD	PROD DATE	WARR DATE	SELLING DEALER	SELL CNT	TIS	WCC	PREF	BASE	SUFF	VRT NA	VRT ROW	VFG	CCC	CD
1FTSW21R78[REDACTED]		T/F7	F	T/BC	T/BD	T/E	A1	T/BE	T/QL	17-MAY-2007	09-NOV-2007	152037	USA	0	7S12	*	14A005	*	F03	S09	V17	S39	X2
AWS Claim Key:		<u>220127</u>	Doc #: 07970451		Trx Code:		1	Labor Hrs:		9	Labor Cost:		72.84	Material Cost:		0	Total Cost:		72.84				
Dir Cd-Sub Cd:		03759-*	Name: FREEWAY FORD				Ph:	281-5885000	St: TX	Ctry Cd:	USA	Reg Cd:	NA	Repr Date: 08-NOV-2007		DIST(Mile): 25							
Cust Comments:		AIR BAG LIGHT ON																					
Tech Comments:		AIR BAG SYS DIAG B2691 PINPOINT LOCATE AND REPAIR OPEN IN CIRCUIT CLR CODES RETESTCIRCUIT CR201 AT C3065 PIN 1 BU OG WIRE14A005 HARNESS																					
1FTSW21R78[REDACTED]		T/F7	F	T/BC	T/BD	T/E	A1	T/BE	T/QL	17-MAY-2007	09-NOV-2007	152037	USA	13	5G02	*	3078	*	F05	S05	V39	N51	33
AWS Claim Key:		<u>2237544</u>	Doc #: 09558253		Trx Code:		E84	Labor Hrs:		8	Labor Cost:		67.66	Material Cost:		0	Total Cost:		67.66				
Dir Cd-Sub Cd:		03759-*	Name: FREEWAY FORD				Ph:	281-5885000	St: TX	Ctry Cd:	USA	Reg Cd:	NA	Repr Date: 17-NOV-2008		DIST(Mile): 8223							
Cust Comments:		CUSTOMER STATES HEARS POPPING NOISE WHEN TURNING HARD																					
Tech Comments:		ROAD TEST, CHECK AND TIGHTEN ALL FRT SUSPENSION BOLTS TO CORRECT NOISE WHILE TUNING OVER BUMPS																					
1FTSW21R78[REDACTED]		T/F7	F	T/BC	T/BD	T/E	A1	T/BE	T/QL	17-MAY-2007	09-NOV-2007	152037	USA	13	1A03	8C3Z	6009	A	F04	S11	V29	E29	01
AWS Claim Key:		<u>2286198</u>	Doc #: 09558252		Trx Code:		E84	Labor Hrs:		41.1	Labor Cost:		3475.86	Material Cost:		6234.38	Total Cost:		10470.24				
Dir Cd-Sub Cd:		03759-*	Name: FREEWAY FORD				Ph:	281-5885000	St: TX	Ctry Cd:	USA	Reg Cd:	NA	Repr Date: 17-NOV-2008		DIST(Mile): 8223							
Cust Comments:		CUSTOMER STATES VEHICLES CHECK ENGINE LIGHT ON, LEAKING OIL, RUNNING ROUGH AND BLOWING BLACK SMOKE																					
Tech Comments:		VERIFY CONCERNS.ENGINE RUNNING ROUGH,LIGHT ON,AND LEAKING OIL VISUAL INSPECTION FOUND OIL IN EXHAUST SYS.OIL LEAK DIAGNOSIS FOUND PASS GLOW PLUG HARNESSPASS SIDE DETACHED.RETRIEVE DTCS P0266,0302,0673,2291 DIESEL ENGINE PERFORMANCE DIAGNOSIS FOUND MISFIRE CYLINDER 2.RELATIVE COMPRESSION LOW CYLINDER 2 MANUAL COMPRESSION TEST FOUND CYL 2, 0 PSI,410 415 REMAINING CYLINDERS.NECESSARY TO TEARDOWN ENG																					

IFTSW21R78 [REDACTED] T/F7 F T/BC T/BD T/E A1 T/BE T/QL 17- MAY- 09- NOV- 152037 USA 13 1F01 * * * F09 SXX V00 * *

AWS Claim Key: 2237543 **Doc #:** 09558242 **Trx Code:** 08B06 **Labor Hrs:** 3 **Labor Cost:** 25.37 **Material Cost:** 3.92 **Total Cost:** 29.29

Dir Cd-Sub Cd: 03759-* **Name:** FREEWAY FORD **Ph:** 281-5885000 **St:** TX **Ctry Cd:** USA **Reg Cd:** NA **Repr Date:** 17-NOV-2008 **DIST(Mile):** 8223

Cust Comments: PROGRAM 08B06: DIESEL ENGINE COOLING SYSTEM

Tech Comments: INSTALL A VENTURI KIT INTO THE DEGAS BOTTLE AND RADIATOR VENT HOSES PER PROGRAM

IFTSW21R78 [REDACTED] T/F7 F T/BC T/BD T/E A1 T/BE T/QL 17- MAY- 09- NOV- 152037 USA 14 2E03 8C3Z 9A543 B F04 S11 V52 D42 42

AWS Claim Key: 2335109 **Doc #:** 09641251 **Trx Code:** S07 **Labor Hrs:** 14.1 **Labor Cost:** 1192.44 **Material Cost:** 1169.82 **Total Cost:** 2362.26

Dir Cd-Sub Cd: 03759-* **Name:** FREEWAY FORD **Ph:** 281-5885000 **St:** TX **Ctry Cd:** USA **Reg Cd:** NA **Repr Date:** 08-DEC-2008 **DIST(Mile):** 8343

Cust Comments: CUSTOMER STATES STALLED WHILE DRIVING

Tech Comments: VERIFY CONCERN ENG DIES WHILE DRIVING, RESTART COLD SOAK, RETREIVE DTC P0090, PPT INCONCLUSIVE, LOW PRESS FUEL TEST PASS, HIGH PRESS FUEL TEST PASS, DATE MONITOR FOUND FRP DROP TO 3400 PSI UNDER LOAD (15000 DESIRED) CONTACT HOTLINE, PERF HIGH PRESS FUEL PUMP HARNESS SHORT TO FROUND TEST, PASS, REPL HIGH PRESS FUEL PUMP AS PER HOTLINE RECOMMENDATION, REASSEMBLE RETEST, ALL OK AT THIS TIME.

IFTSW21R78 [REDACTED] T/F7 F T/BC T/BD T/E A1 T/BE T/QL 17- MAY- 09- NOV- 152037 USA 14 2E03 8C3Z 9A543 B F04 S11 V52 D21 42

AWS Claim Key: 2509400 **Doc #:** 09692551 **Trx Code:** E91 **Labor Hrs:** 15.3 **Labor Cost:** 1293.92 **Material Cost:** 1277.43 **Total Cost:** 2666.35

Dir Cd-Sub Cd: 03759-* **Name:** FREEWAY FORD **Ph:** 281-5885000 **St:** TX **Ctry Cd:** USA **Reg Cd:** NA **Repr Date:** 20-DEC-2008 **DIST(Mile):** 8510

Cust Comments: CUSTOMER STATES VEHICLE DIED WHILE DRIVING

Tech Comments: VERIFY CONCERN, ENGINE STALLING, NO START HOT, RETREIVE DTC P0090, OOT ME PASS HIGH PRESSURE FUEL PUMP, LIFT PUMP PRESS 6 PSI, FUEL QUALITY OK, FP FAULT PID YES DURING CONCERN, CONTACT HOTLINE, OHM RESISTANCE TEST AS PER HOTLINE PASS, SPEC 1.5 150 HM CONCERN PRESENT, PIN 1 TO 3 HIGHT PRESSURE PUMP 6.50 HM CONCERN PRESENT, NO CONCERN, READING 19.3 OHM TO PUMP, INSTRUCTED TO REPLACE PUMP AS PER HOTLI

IFTSW21R78 [REDACTED] T/F7 F T/BC T/BD T/E A1 T/BE T/QL 17- MAY- 09- NOV- 152037 USA 16 1F01 8C3Z 8009 B F04 S11 V45 E23 D1

AWS Claim Key: 2987762 **Doc #:** 09946251 **Trx Code:** E84 **Labor Hrs:** 2.7 **Labor Cost:** 228.34 **Material Cost:** 565.24 **Total Cost:** 793.58

Dir Cd-Sub Cd: 03759-* **Name:** FREEWAY FORD **Ph:** 281-5885000 **St:** TX **Ctry Cd:** USA **Reg Cd:** NA **Repr Date:** 26-FEB-2009 **DIST(Mile):** 9578

Cust Comments: CUST STATES VEHICLE IS LEAKING COOLANT OVER HEATING

Tech Comments: VERIFY CONCERN, ENGINE LEAKING COOLANT, COOL SYS PRESS TEST FAIL RADIATOR, INSTALL NEW RETEST, ALL OK AT THIS TIME, OIL COOLANT DYE

IFTSW21R78 [REDACTED] T/F7 F T/BC T/BD T/E A1 T/BE T/QL 17- MAY- 09- NOV- 152037 USA 16 2E02 * * * F09 SXX V00 * *

AWS Claim Key: 2975660 **Doc #:** 09946241 **Trx Code:** 08C04 **Labor Hrs:** 9 **Labor Cost:** 76.11 **Material Cost:** 30.72 **Total Cost:** 109.83

Dir Cd-Sub Cd: 03759-* **Name:** FREEWAY FORD **Ph:** 281-5885000 **St:** TX **Ctry Cd:** USA **Reg Cd:** NA **Repr Date:** 26-FEB-2009 **DIST(Mile):** 9578

Cust Comments: 08C04 DEMONSTRATION DELIVERY HOLD FUEL TANK STOPPER BRACKET INSTALLAT

Tech Comments: INSTALL FUEL TANK STOPPER BRACKET

IFTSW21R78F [REDACTED] T/F7 F T/BC T/BD T/E A1 T/BE T/QL 17- MAY- 09- NOV- 152037 USA 16 2G01 * * * F09 SXX V00 * *

AWS Claim Key: 2975670 **Doc #:** 09946242 **Trx Code:** 08B07 **Labor Hrs:** .5 **Labor Cost:** 42.29 **Material Cost:** 0 **Total Cost:** 42.29

Dir Cd-Sub Cd: 03759-* **Name:** FREEWAY FORD **Ph:** 281-5885000 **St:** TX **Ctry Cd:** USA **Reg Cd:** NA **Repr Date:**26-FEB-2009 **DIST(Mile):**9578

Cust Comments: 08B07 CERTAIN 2008 MODEL YEAR F SUPER DUTY VEHICLES EQUIPPED WITH A 6.4

Tech Comments: REPROGRAM THE PCM, TCM AND IC USING IDS RELEASE 58.4

IFTSW21R78F [REDACTED] T/F7 F T/BC T/BD T/E A1 T/BE T/QL 17- MAY- 09- NOV- 152037 USA 16 6E01 * * * F09 SXX V00 * *

AWS Claim Key: 2975668 **Doc #:** 09946240 **Trx Code:** 08C01 **Labor Hrs:** .3 **Labor Cost:** 25.37 **Material Cost:** 11.9 **Total Cost:** 37.27

Dir Cd-Sub Cd: 03759-* **Name:** FREEWAY FORD **Ph:** 281-5885000 **St:** TX **Ctry Cd:** USA **Reg Cd:** NA **Repr Date:**26-FEB-2009 **DIST(Mile):**9578

Cust Comments: 08C01 DEMONSTRATION DELIVERY HOLD PERFORM PRIOR TO VEHICLE DELIVERY

Tech Comments: INSPECT THE FRONT DRIVER SEAT BACK AND INSTALL CLAMP KIT

IFTSW21R78F [REDACTED] 7 T/F7 F T/BC T/BD T/E A1 T/BE T/QL 17- MAY- 09- NOV- 152037 USA 35 1H03 8C3Z 9D475 D F04 S11 V29 E29 42

AWS Claim Key: 6487155 **Doc #:** 079004A **Trx Code:** S07 **Labor Hrs:** .9 **Labor Cost:** 78.3 **Material Cost:** 196.66 **Total Cost:** 274.96

Dir Cd-Sub Cd: 04528-* **Name:** TOMMIE VAUGHN MOTORS, INC. **Ph:** *.* **St:** TX **Ctry Cd:** USA **Reg Cd:** NA **Repr Date:**02-SEP-2010 **DIST(Mile):**32320

Cust Comments: E29 CUSTOMER STATES ENGINE LIGHT ON & SLOW TO ACCEL AT TIMES

Tech Comments: VERIFIED CUSTOMERS CONCERN AND PERFORMED DIESEL DIAG FOUND OIL AND FUEL OK. PERFRED KOEO AND FOUND DTC P1335.VERIFY NO LATER CALIBRATION AVAILABLE. REFERED TO PIN POINT TEST W AND PERFORMED EGR SYSTEM TEST AND FOUND EGR VALVE TOFAIL AT 3.4 VOLTS. REPLACED EGR VALVE AND ROAD TESTED AND RETESTED FOUND SYSTEM OPERATIN CORRECTLY.

Any comments? You can contact



webmaster

PE13-014

FORD

7/10/2013

Appendix E

Subject - Lawsuits and Claims

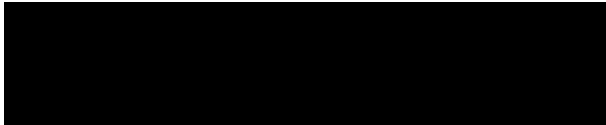

Case



General Info

Overview

Case Number	[REDACTED]	Status	Active
Priority	[REDACTED]	Owner	Tier 1 Inbound
Expected Resolution Date	[REDACTED]	Status Reason	Active New
Input Channel	Phone		

Customer Info

Customer Name	[REDACTED]	Caller Type	
Customer Delegate	[REDACTED]	Use for Reply-To	
Phone			
Relationship			

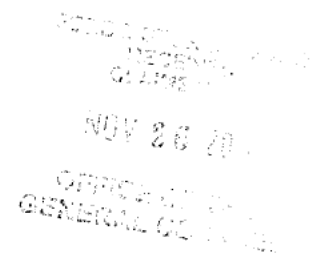

Customer Scores

Loyalty Score		Defector Score	
CLP LTV Score		Dissat Score	
In-Market		ESP Score	
Likelihood to Service		Service Segments	

Dealer Info

Dealer Info

Dealer	Airport Marina Ford
Dealer Contact	
Portal Status	No New Message
FMCC Branch Code	

Vehicle Info

Vehicle Info

VIN	1FTSX20508E [REDACTED]	Hours in Service	
------------	--	-------------------------	--

Converted Mileage		Mileage
Vehicle Modifications	No	Mileage Units
Engines Specification		Transmissions Specification
Number of Repairs		Days Out of Service

Vehicle Specification

Vehicle Specification Full Path [2008 > FORD > F-SERIES SUPER DUTY > X20 - F250 4X2 SUPERCAB - SRW](#)

Model Year [2008](#)

Make [FORD](#)

Model / Vehicle Line [F-SERIES SUPER DUTY](#)

Body Style [X20 - F250 4X2 SUPERCAB - SR](#)
W

Case Classification

Classification

Responsible Team [Tier 1 Inbound](#)

Case Classification Full Path [Vehicle Concern > Legal > Alleged Accident > Not Portal](#)

Case Classification Level 1 [Vehicle Concern](#)

Case Classification Level 2 [Legal](#)

Case Classification Level 3 [Alleged Accident](#)

Case Classification Level 4 [Not Portal](#)

Classification

Initial Contact Target	Initial Contacted	No
Case Closure Target	Initial Contact Date	

Symptom Code

Symptom Code [Comfort & Entertainment > Audio > Steering Wheel Control > Inoperative](#)

Level 1 [Comfort & Entertainment](#)

Level 2 [Audio](#)

Level 3 [Steering Wheel Control](#)

Level 4 [Inoperative](#)

Miscellaneous Info**Miscellaneous Info**

Master Case

Caller Authorization Code 0000112467

Stars ID

Tech Hotline No

Contract Info

ESP Contract #**Warranty Start Date**

Ford Credit Contract #

Form Letter Code

Non-Ford ESP No

Notes & Article**Notes**

 Title: Note created on 11/19/2012 03:36 PM by Michele Demara
Note created on 11/19/2012 3:36 PM by Michele Demara

Edited 11/19/2012 3:36 PM by Michele Demara

****cust said****

-----had an accident 2 weeks ago-----steering went out and hit a parked veh-----

****Accidents****

1. Date of the accident

-----10/30/12

2. What the customer is alleging the product defect is that caused Accident

-----Steering /////wheel just goes around no steering

3. If there were any injuries sustained

-----no

4. Location of the vehicle when the accident occurred

-----on a residential street los angles CA

5. Whether or not there was a police report filed.

-----no

6. If a police report was filed, what the findings were.

-----n/a

7. The police report number and the city or county in which the report was filed.

-----n/a

8. Whether or not the customer has filed a claim with their Insurance Company.

-----yes---cust only has liability

9. If a claim has been filed with the insurance company, what is the status of the claim.

-----will repair other veh

10. Whether or not the vehicle is repairable.

-----yes

11. Name and address of customer's attorney (only if the customer mentions they have sought one).

12. What the customer is seeking

-----wanted to see if any recalls and if he should check ----cust says cost to cost 3.000 just for parts-----looking for f/a for this repair to see if this was the cause of the problem

****dealer info****

-----Airport Marina Ford (05563)

5880 Centinela Ave.

Los Angeles, CA 90045

(877) 999-9546

****crc advised****

-----I will be sending this info to our Legas dept for review-----please allow 15 business days to receive a packet in the mail in regards to this issue-----

Article

Article

Admin Info

Admin Info

Created By  Michele Demara

Modified By  Michele Demara

Created On 11/19/2012 3:36 PM

Modified On 11/19/2012 3:36 PM

Begin Date 11/19/2012

Case Type

Title CAS-1868110-



BEGINNING OF CONTACT
09/15/2009

VOICE OF THE CUSTOMER TRACKING SYSTEM

08.00.02

=====

REGION:	A1 SELECT DEALER	OGC ISSUE	CASE NBR:	1376302579	
VIN:	1FTWW31R38E [REDACTED]	ZONE: C07	OPENED:	09/14/2009	
		ENGINE: R	VEH TYPE: T	CLOSED:	09/14/2009

=====

LAST NAME:	[REDACTED]	FIRST NAME:	[REDACTED]	STATUS:	CLOSED
TITLE:	[REDACTED]	MI:	[REDACTED]		
ADDRESS:	[REDACTED]				
CITY:	TONGANOXIE	STATE:	KS	ZIP:	[REDACTED]
HOME PHONE:	[REDACTED]				
MODEL YEAR:	2008	MODEL:	F350 4X4 CREWCAB - SRW		
MILEAGE:	70000				
DEALER NAME:	BONNER SPRINGS FORD	SALES CODE:	F53403	P & A:	05233
REASON CODE:	0796 LEGAL - ALLEGED INJURY				
SYMPTOMS:	303A00 STEERING/HANDLING STEERING WHEEL				

ORIGIN: CACI38 - US CONCERN CASE BASE COMMUNICATION: PHONE
ACTION: 705 - CONTACT ADVANCED TO OGC
DOCUMENT: ANALYST: GEPPINGE EPPINGER , GREGORY

FORD MOTOR COMPANY
RECEIVED
CLAIMS UNIT

DATE: 09/14/2009 TIME: 10.27.09 :
ACTION DATA/COMMENTS:

SEP 15 2009

CUSTOMER SAID: VIN: 1FTWW31R38E [REDACTED] YR/MK/MOD:2008 F-350 OD
O:70000NAME [REDACTED] =
=====DETAILS:-CUST SAYS-AT 1100 MILES THE
STEERING WHEEL CEASED FUNCTION-DLR FIXED-ACCIDENT OCCURRED
DUE TO STEERING WHEEL FAILURE-WHEEL HAS ABSOLUTELY NO EFFECT
ON STEERING-AIRBAGS DID NOT DEPLOY, BUT CUST BELIEVES THEY
SHOULD HAVE-CUST HAS A TOW BILL-CUST HAS NOT HAD ANY PROBLEM
WITH FORD AS A COMPANY***ACCIDENT***1. 9-11-09, 4:00PM2. ST
EERING WHEEL FAILURE3. YES,CUST HIT HEAD BUT DID NOT REQUIRE
HOSPITALIZATION4. VEHICLE IS CURRENTLY AT DLRSH5. NO REPOR
T FILED9. NO CLAIM FILED YET10. DLRSH5 HAS NOT DIAGNOSED VEH
ICLE YET, MOST LIKELY FIXABLE12. CUST WANTS VEHICLE VEHICLE
FIXED. CUST DOES NOT WANT VEHICLE. POSSIBLY A BUYBACK.DEALER
SAID: BONNER SPRINGS FORD INC715 SOUTH 130TH STREETBONNER S
PRINGS KS 66012(913) 422-2045CRC ADVISED: I WILL FORWARD YOU
R INFORMATION TO FORD'S OFFICE OF THE GENERAL COUNSEL. YOU
SHOULD RECEIVE A WRITTEN RESPONSE WITHIN 15 BUSINESS DAYS TO
YOUR CONCERN.NOTE TO CCR: REMEMBER TO VERIFY ALL CUSTOMER C
ONTACT INFORMATION BEFORE SENDING ISSUE.

OFFICE OF THE
GENERAL COUNSEL

CONSUMER AFFAIRS

09/15/2009 FAXOGC1

PE13-014 000007LCSV

Standard Claims List For Model Year 2008

Detailed Vehicle Specification

VIN	VEH LINE	MKT DERIV	BODY CAB	VER SERIES	DRIVE TYPE	PLT CD	TRS CD	ENG CD	PROD DATE	WARR DATE	SELLING DEALER	SELL CNT	TIS	WCC	CPSC_6	PREF	BASE	SUFF	CCC	CD	DIST (Miles)
1FTWW31R381[REDACTED]		F	T/BC	T/CD	T/E	A1	T/BE	T/QL	12-JUN-2007	27-NOV-2007	153403	USA	5	2G05	031405	*	RECALEM	*	D42	04	11190
AWS Claim Key:		805504	Trx Code:		S07	Labor Hrs:		0.6													
Dir Cd-Sub Cd:		05233 - *	Name:			BONNER SPRINGS FORD, INC.			Ph:	913-4222045	St:	KS	Ctry Cd:		USA	Reg Cd:	NA	Repr Date:	17-APR-2008	Doc #:	17558303
Cust Comments:		LOSES POWER																			
Tech Comments:		RAN IDS REPROGRAM PCM TCM AND IC 07 17 03																			
1FTWW31R381[REDACTED]		F	T/BC	T/CD	T/E	A1	T/BE	T/QL	12-JUN-2007	27-NOV-2007	153403	USA	5	5R14	1106XX	8C3Z	14A664	B	A34	42	11190
AWS Claim Key:		805505	Trx Code:		2	Labor Hrs:		1.1													
Dir Cd-Sub Cd:		05233 - *	Name:			BONNER SPRINGS FORD, INC.			Ph:	913-4222045	St:	KS	Ctry Cd:		USA	Reg Cd:	NA	Repr Date:	17-APR-2008	Doc #:	17558302
Cust Comments:		HORN ENGAGES BY ITSELF																			
Tech Comments:		TEST AND REPLACED CLOCK SPRING																			
1FTWW31R381[REDACTED]		F	T/BC	T/CD	T/E	A1	T/BE	T/QL	12-JUN-2007	27-NOV-2007	153403	USA	5	5001	110201	7C3Z	3504	B	H50	42	11190
AWS Claim Key:		861334	Trx Code:		2	Labor Hrs:		3.3													
Dir Cd-Sub Cd:		05233 - *	Name:			BONNER SPRINGS FORD, INC.			Ph:	913-4222045	St:	KS	Ctry Cd:		USA	Reg Cd:	NA	Repr Date:	17-APR-2008	Doc #:	17558301
Cust Comments:		WHEN TURNING WHEELS WILL NOT TURN																			
Tech Comments:		INSPECT STEERING SHAFT CAME OUT OF STEERING GEAR BOX REPLACED GEAR BOX AND SET CLEAR VISION																			
1FTWW31R381[REDACTED]		F	T/BC	T/CD	T/E	A1	T/BE	T/QL	12-JUN-2007	27-NOV-2007	153403	USA	5	6Y20	000000	*	TAP5	*	A99	82	11190
AWS Claim Key:		812019	Trx Code:		TAP5	Labor Hrs:		0													
Dir Cd-Sub Cd:		05233 - *	Name:			BONNER SPRINGS FORD, INC.			Ph:	913-4222045	St:	KS	Ctry Cd:		USA	Reg Cd:	NA	Repr Date:	17-APR-2008	Doc #:	17558308
Cust Comments:		PROVIDE 4 DAYS LOANER																			
Tech Comments:																					



•

DBG & ASSOCIATES, INC.

KARL J. KESSLER, ARM, AIC
CLAIMS SUPERVISOR
kesslerdbg@sbcglobal.net

119 Dillmont Drive
Suite 105
Columbus, Ohio 43235
614-846-1706-Phone
614-846-1338-Fax

July 1, 2008

FORD MOTOR COMPANY
RECEIVED
CLAIMS UNIT

JUL 09 2008

OFFICE OF THE
GENERAL COUNSEL

The Ford Motor Company
Attn: Risk Management Department
P.O. Box 6248
Dearborn, MI 48126

RE: Insured: [REDACTED]
Claim Number: [REDACTED]
Date of Accident: [REDACTED]
Vehicle: 2008 Ford F250 XLT
VIN: 1FTSX21538E [REDACTED]

Dear Sir or Madam:

DBG & Associates is the authorized claim representative for Greenwich Insurance Company, which insures [REDACTED] under a policy of Automobile Physical Damage.

The above captioned vehicle was involved in a single vehicle accident on June 4, 2008. We paid collision damages under the policy of \$4,784.50 net of our insured's \$500.00 deductible. The purpose of this letter is to notify you of a potential problem with the steering mechanism of this vehicle and to request reimbursement for our insured's damages. The failure of the steering system on this new vehicle caused our insured to lose the ability to steer and control the vehicle.

We enclose a copy of the independent damage appraisal performed by Crawford & Company as well as photos and copies of our claim check. Please reimburse Greenwich Insurance Company the total repair amount of \$5,284.50. Upon receipt of this amount we will reimburse our insured their \$500.00 deductible.

Thank you for your cooperation and we look forward to your prompt payment.

Sincerely,

DBG & ASSOCIATES, INC.

Karl J. Kessler, ARM, AIC
Claims Supervisor

KJK/mam

Encl.



Office of the General Counsel

PRIVILEGED & CONFIDENTIAL
Ford Motor Company
Claims Department
P.O. Box 70
Dearborn, Michigan 48121-0070

RECEIVED
JUL 29 2008
BY:

July 24, 2008

DBG & Associates, Inc.
119 Dillmont Dr., Suite 105
Columbus, OH 43235

ATTENTION: [REDACTED]

RE: Your Insured: [REDACTED]
Your Claim #: [REDACTED]
DOL: 06/04/08

Dear [REDACTED]

We acknowledge your recently submitted subrogation claim letter. In order to assist us in evaluating your claim, we request that you provide us with the following information: (Please note that the information requested is in regard to the Ford manufactured vehicle.)

- 1. Attach your insured's statement with a complete description of the incident, including events that occurred prior to and subsequent to the loss.
- 2. A copy of the police and/or fire report.
- 3. Original color photographs of the vehicle's collision/fire damage & the alleged defective parts, from several different angles.
- 4. Original color photographs of the inside of the vehicle showing the steering wheel, dash and roof areas.
- 5. Original color photographs of the accident / fire scene from several different angles.
- 6. Attach a copy of your expert's report and the expert's original color photographs.
- 7. Attach the repair estimate, repair order, or your total loss worksheet for the vehicle's damage and any losses associated with this incident, and copies of draft payments.
- 8. Attach the complete service history for the subject vehicle, including any tune-ups or oil changes.

Please answer the following in the space provided. If you need additional space, please use the back of the form;

- 9. What was the city and state of occurrence: Dimock, PA.
- 10. The 17 digit vehicle identification number: 1FTSX21538E [REDACTED]
- 11. What was the mileage at time of occurrence: 24,169
- 12. What is the alleged defect: Steering box failed
- 13. Has the alleged defective part been repaired or replaced? (circle one) Yes or No

14. What is the current location of the vehicle, and the alleged defective part(s)?
Dimock, Pa
15. List all after market additions or modifications that were made to the vehicle:
Tool box in Bed
16. Was the engine running? (circle one) Yes or No
17. Were the keys in the ignition? (circle one) Yes or No
18. Was this vehicle purchased new or used: New
If purchased used, provide the date of purchase, mileage at the time of purchase, and from whom the vehicle was purchased: _____

Once we are in receipt of the requested information, it will be reviewed and you will be notified of our decision concerning your claim. Should you not send all of the requested information and materials within 90 days, we will assume that you are not interested in pursuing a claim and we will close our file. Please note that your vehicle will not be inspected until all the above information has been submitted and a determination has been made as to whether an inspection is warranted.

Please be advised that all necessary steps should be taken to ensure that the incident scene, the subject vehicle and all of its component parts are maintained and preserved. Ford Motor Company has the right to inspect the fire scene and the vehicle and remove and test any vehicle component part that you claim to be defective, and to be presented with the vehicle and the subject component part(s) at the time of trial, should litigation ensue from this informal claim.

If you propose to repair the vehicle for continued usage, such repairs may not be performed until after Ford Motor Company has inspected the vehicle and removed and tested any component part you claim to be defective or advised you in writing that it does not intend to perform such inspection and/or testing at this time. But even in that event, Ford Motor Company will insist that all components claimed to be defective are maintained and preserved for trial.

Sincerely,

AT LW

Alma Taylor
Claims Analyst

Images

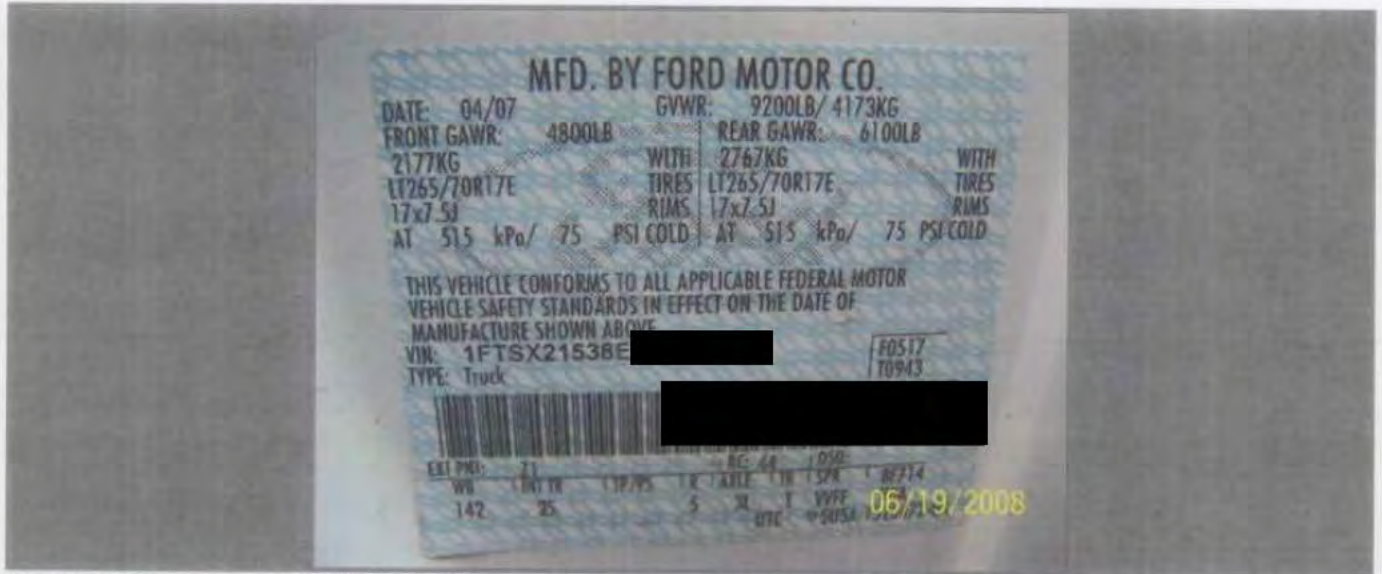

Attached Date/Time: 6/20/2008 8:37:29 AM

Comment: VIN



Attached Date/Time: 6/20/2008 8:37:29 AM

Comment: Steering Gear

Claim Number: [REDACTED] Policy Number:



Attached Date/Time: [REDACTED]:37:29 AM

Comment: Steering Gear



Attached Date/Time: [REDACTED] 8:37:29 AM

Comment: Steering Gear-debris

Claim Number: [REDACTED] Policy Number:



Attached Date/Time: [REDACTED] 8:37:29 AM

Comment: Steering Gear as it goes together



Attached Date/Time: [REDACTED] 8:37:30 AM

Comment: Steering Gear

Claim Number [REDACTED] Policy Number:



Attached Date/Time: [REDACTED] 8:37:30 AM

Comment: R front wheel/tire



Attached Date/Time: [REDACTED] 8:37:30 AM

Comment: R front suspension

Claim Number: [REDACTED] Policy Number:



Attached Date/Time: [REDACTED] 8:37:30 AM

Comment: R fender



Attached Date/Time: [REDACTED] 8:37:30 AM

Comment: R tow hook damaged

Claim Number: [REDACTED] Policy Number:



Attached Date/Time: [REDACTED] 8:37:30 AM

Comment: Grille



Attached Date/Time: [REDACTED] 8:37:31 AM

Comment: Grille

Claim Number: [REDACTED] Policy Number:



Attached Date/Time: [REDACTED]:37:31 AM

Comment: Front bumper



Attached Date/Time: [REDACTED]:37:31 AM

Comment: R headlamp

Claim Number: [REDACTED] Policy Number:



Attached Date/Time: [REDACTED] 8:37:31 AM

Comment: R rear tire gouged



Attached Date/Time: [REDACTED] 8:37:31 AM

Comment: R rear tire cut

Claim Number: [REDACTED] Policy Number:



Attached Date/Time: [REDACTED] 8:37:32 AM

Comment: R running board



Attached Date/Time: [REDACTED] 8:37:32 AM

Comment: R running board

Claim Number: [REDACTED] Policy Number:



Attached Date/Time: [REDACTED] 8:37:32 AM

Comment: R. front mudguard



Attached Date/Time: [REDACTED] 8:37:32 AM

Comment:

Claim Number: [REDACTED] Policy Number:



Attached Date/Time: [REDACTED]:37:32 AM

Comment:



Attached Date/Time: [REDACTED]:37:32 AM

Comment:

Claim Number: [REDACTED] Policy Number:



Attached Date/Time: [REDACTED] 8:37:33 AM

Comment:

Claim Number: [REDACTED] Policy Number:



HEAGEN, PAGANO & SEEMS, PC

ATTORNEYS AT LAW

MATTHEW J. HEAGEN
mheagen@hpslawyers.com

ANTHONY M. PAGANO
apagano@hpslawyers.com

PETER T. SEEMS, JR.
pseems@hpslawyers.com

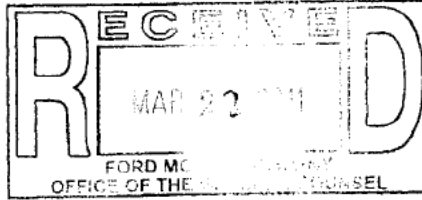

325 W. Water Street
Toms River, New Jersey 08753

732-286-9800
(fax) 732-286-1666
(real estate fax) 732-240-5722

March 17, 2011

Ford Motor Company
Customer Relationship Center
P.O. Box 6248
Dearborn, MI 48126

Re: [REDACTED]

Dear Sir/Madam:

Please be advised that I have been retained to represent the interests of [REDACTED] regarding to a claim that the passenger vehicle that he purchased is a "Lemon" under the New Jersey Lemon Law N.J.S.A. 56:12-29 to 56:12-49. I am hereby making a written demand for relief under the "Lemon Law". The vehicle was purchased on July 2, 2009 from Meadowland Ford Truck Sales, located at 330 County Avenue, Secaucus, NJ. Since the vehicle was purchased, it has been returned to the dealership on five (5) separate occasions for repair. The vehicle has been out of service for approximately 20 calendar days and the current mileage reading is 53,000 miles.

I enclose a copy of the New Jersey Lemon Law application, as well as copies of invoices received from Meadowland Ford Truck Sales. As you can see, since the date of purchase, the vehicle has had suspension problems in which the front end wanders, thereby making it unsafe to drive. Since these defects substantially impair the use, value or safety of the vehicle, I am hereby allowing you one final opportunity to repair the vehicle. If these repairs are not completed within 10 calendar days from the receipt of this letter, I am entitled to a refund calculated in accordance with the Lemon Law.

I look forward to hearing from you soon and you can reach me as indicated hereinabove.

Very truly yours,

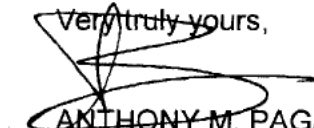
ANTHONY M. PAGANO
For the Firm

AMP:dmf
Enclosures
Via certified:r.r.r. and regular mail
cc: [REDACTED]

OFFICE OF THE
GENERAL COUNSEL
11 MAR 22 P 6
LITIGATION
PRACTICE GROUP

CONSUMER AFFAIRS



New Jersey Office of the Attorney General

Division of Consumer Affairs
Used Car Lemon Law Unit
P.O. Box 45026
Newark, New Jersey 07101
(973) 504-6226
(800)-242-5846

E-Mail: lemonlaw@dca.lps.state.nj.us

Please be advised that any information you supply on this complaint form may be subject to public disclosure. If an investigation into the matter is conducted, the information is subject to public disclosure only after the completion of the investigation. You are also advised that the completed complaint form is a "government record," which the Used Car Lemon Law Unit may be obligated to provide to anyone making a request pursuant to the Open Public Records Act (OPRA).

CONSUMER INFORMATION:

DEALER INFORMATION:

Form with fields for NAME, ADDRESS, CITY, STATE, HOME TELEPHONE NUMBER, WORK TELEPHONE NUMBER, E-MAIL ADDRESS, BUSINESS, ADDRESS, CITY, STATE, ZIP, TELEPHONE NUMBER (1), TELEPHONE NUMBER (2).

1. Vehicle Information: Make FORD, Model F350 4x4 CREW CAB, Year 2008, Date of Purchase 7-2-09, Purchase Price 43,300.
2. Vehicle Identification Number (VIN) 1FTWW31R28...
3. Mileage, on date of purchase: 0, Mileage, at present: 53,000
4. a. Is your vehicle normally used for personal, family or household purposes? [X] Yes [] No
b. Is your vehicle normally used for commercial purposes? [] Yes [X] No
5. Does the material defect substantially impair the use, value or safety of the vehicle? [X] Yes [] No
6. Were you advised, in writing, at or prior to the time of purchase that the vehicle was declared a total loss by an insurance company? [] Yes [X] No
7. Warranty Information (Please check all that apply.)
[] I purchased the vehicle AS IS.
[] I was given a limited dealer warranty at no extra charge.
Duration of warranty: [] 30 days/1,000 miles [] 60 days/2,000 miles
[] 90 days/3,000 miles [] Other
[X] I purchased an extended service contract. (Please provide a copy.)
Warranty Company:
Street Address: City: State: ZIP:
Telephone Number (include area code):

8. a. If the vehicle's mileage was more than 60,000 at the time of purchase, did you waive the warranty? Yes No
 b. Did you sign a waiver form? Yes No If "Yes," please provide a copy of the waiver.

9. Repair Information (Use additional sheets of paper if needed.)

What is the malfunction or material defect you are claiming? PULLS TO LEFT WHILE DRIVING

10. a. Did you notify the dealer of the problem described in question #9? Yes No
 b. If "Yes," on what date? 7-2-09 What was the mileage at that time? _____

11. Were three (3) or more repair attempts made for the same problem? Yes No

12. Were all three (3) repair attempts made within the warranty period? Yes No

13. Do any of the alleged defects still exist? Yes No
 For each alleged defect:

Description of problem

Date & Mileage of each repair attempt

a. suspension pulls + front end wanders	Date: <u>7/6/09</u> Mileage: <u>370</u> 1 st Attempt
	Date: <u>9/14/09</u> Mileage: <u>7,774</u> 2 nd Attempt
	Date: <u>6/7/10</u> Mileage: <u>33,511</u> 3 rd Attempt
b.	Date: <u>6/21/10</u> Mileage: <u>34,637</u> 4 th Attempt
	Date: <u>8/3/10</u> Mileage: <u>35,289</u> 5 th Attempt
	Date: _____ Mileage: _____ 3 rd Attempt
c.	Date: _____ Mileage: _____ 1 st Attempt
	Date: _____ Mileage: _____ 2 nd Attempt
	Date: _____ Mileage: _____ 3 rd Attempt

14. a. Was the vehicle out of service for a total of 20 or more calendar days, due to repairs? Yes No
 b. If "Yes," how many days? 21

- c. List the dates below: SEE INVOICES ATTACHED
- From _____ to _____ number of days _____
 - From _____ to _____ number of days _____
 - From _____ to _____ number of days _____

15. a. Was the vehicle repaired by anyone other than the dealer or its agent? Yes No
 b. If "Yes," where?

Name: _____
 Street Address: _____ City: _____ State: _____ ZIP: _____
 County: _____ Telephone Number (include area code): _____

16. Financial Information

Total purchase price \$ 43,300.00 Trade-in allowance \$ _____
 Down payment (for that portion of the purchase price that is financed) \$ 2,000.00
 Monthly payment (for that portion of the purchase price that is financed) \$ 642.97
 Total amount of monthly payments made to date (monthly payment X number of payments) \$ 20
 Registration, title, and other government fees \$ 754.00
 Total amount paid (excluding sales tax) \$ 43,686.00 Sales tax \$ _____
 Name of lienholder: Ford Credit
 Street Address: _____ City: _____ State: _____ ZIP: _____
 Account Number: _____ Telephone Number (include area code): _____

17. Additional Information

Have you participated in any previous arbitration for the same problem(s) for which you are seeking relief? Yes No
 a. If "Yes," what type of arbitration? _____ Date of arbitration _____
 b. Did you accept the decision? Yes No If "Yes," please explain and give the current status: _____

18. If an attorney is going to represent you, please provide the following information:

Name: [Redacted] Firm Name: [Redacted]
 Street: [Redacted] City: TOMS RIVER State: NJ
 County: OLEAN Telephone Number (include area code): [Redacted]
 Fax: [Redacted]

I certify that the dealer has not yet given me a refund, and that all statements made in the complaint are true to the best of my knowledge.

I certify that the foregoing statements made by me are true. I am aware that if any of the foregoing statements made by me are willfully false, I am subject to punishment. I authorize the New Jersey Division of Consumer Affairs to send this complaint form to the [Redacted] in any way that is necessary.

 Date 2/16/11

If you have not already done so, please attach clear and legible copies (do not send originals) of the following:

- All relevant evidence of repair attempts
 - sales invoice
 - purchase order
 - finance contract (if financed)
 - vehicle registration
 - repair receipts
 - Used Car Buyer's Guide (window sticker)



MEADOWLAND FORD TRUCK SALES INC.

330 County Avenue
Secaucus, New Jersey 07096

SALES: (201) 617-0700 FAX: (201) 617-9843
Mon. thru Fri. 8 to 6; Sat. 9 to 1
SERVICE: (201) 617-5577
Mon thru Fri. 7:30 - 7:00 Sat. 8:00 - 3:00
PARTS: (201) 617-5200 FAX: (201) 617-9793
Mon. thru Fri. 7:30 - 7:00 Sat. 8:00 - 12:00

Called

CELL: [REDACTED]

CUSTOMER NO. 28025	ADVISOR MICHAEL COAKLEY	TAG NO. 2552	INVOICE DATE 07/09/09	INVOICE NO. FTCS192577
[REDACTED]	LABOR RATE 108.00	LICENSE NO.	MILEAGE 370	COLOR OXFORD WHIT
[REDACTED]	YEAR / MAKE / MODEL 08 / FORD TRUCK / F350 / TRK CREW CAB SRW	VEHICLE I.D. NO. 1 FTWW31R28E	DELIVERY DATE 07/02/09	STOCK NO. 1293
BAYONNE, NJ	F.T.E. NO.	PHONE	SELLING DEALER NO.	DELIVERY MILES 39
RESIDENCE PHONE	BUSINESS PHONE	COMMENTS	R.O. DATE 07/06/09	PRODUCTION DATE
[REDACTED]	[REDACTED]	[REDACTED]	[REDACTED]	[REDACTED]

MO: 375

LABOR

CUST STATES DRIVER REAR DOOR WINDOW INOP
VERFIY CONCERN REMOVE DOOR PANEL CK MOTOR FOUND INOP REPLACE
MOTOR REGULATOR ASSEMBLE REINSTALL PANEL RECHECK OK.

PARTS	QTY	FP-NUMBER	DESCRIPTION	UNIT PRICE	WARRANTY
	1	8C3Z-2627001-B	REGULATO 1 375282		0.00
				TOTAL - PARTS	0.00

JOB# 1 TOTALS

JOB# 1 - JOURNAL PREFIX - FTCS JOB# 1 TOTAL 0.00

JOB# 2 CHARGES

LABOR

Added Operation (MIKEC @ 07/08/2009 12:11)
CUST STATES CK FT SUSPENSION PULLS TO THE LEFT
ROAD TEST VECHILE INSPECT FT SUSPENSION OK ROTATE FT TIRES
LEFT TO RIGHT REROAD TEST OK.

JOB# 2 TOTALS

JOB# 2 JOURNAL PREFIX FTCS JOB# 2 TOTAL 0.00

TOTALS

*****			TOTAL LABOR....	0.00
* [] CASH [] CHECK CK NO. [] *			TOTAL PARTS....	0.00
* [] VISA [] MASTERCARD *			TOTAL SUBLET...	0.00
* [] AMEX [] CHARGE *			TOTAL G.O.G....	0.00
*****			TOTAL MISC CHG.	0.00
			TOTAL MISC DISC	0.00
			TOTAL TAX.....	0.00
			TOTAL INVOICE \$	0.00

THANK YOU FOR YOUR BUSINESS!!

PLEASE PRINT NAME

CUSTOMER SIGNATURE

15 CUSTOMER COPY [END OF INVOICE] 01:41pm



MEADOWLAND FORD TRUCK SALES INC.

330 County Avenue
Secaucus, New Jersey 07096

SALES: (201) 617-0700 FAX: (201) 617-9843
 Mon. thru Fri. 8 to 6; Sat. 9 to 1
 SERVICE: (201) 617-5577
 Mon thru Fri. 7:30 - 7:00 Sat. 8:00 - 3:00
 PARTS: (201) 617-5200 FAX: (201) 617-9793
 Mon. thru Fri. 7:30 - 7:00 Sat. 8:00 - 12:00

Called

CELL: [REDACTED]

CUSTOMER NO. 28025	ADVISOR MICHAEL COAKLEY	2552	TAG NO. 7222	INVOICE DATE 09/15/09	FTCS193122
[REDACTED]	LABOR RATE 108.00	LICENSE NO.	MILEAGE 7,774	COLOR OXFORD WHIT	STOCK NO. 1293
BAYONNE, NJ	YEAR / MAKE / MODEL 08/FORD TRUCK/F350/TRK CREW CAB SRW			DELIVERY DATE 07/02/09	DELIVERY MILES 39
[REDACTED]	VEHICLE I.D. NO. 1FTWW31R28E		[REDACTED]	SELLING DEALER NO.	PRODUCTION DATE
[REDACTED]	F.T.E. NO.	P.	[REDACTED]	S.O. DATE 09/14/09	
COMMENTS					MO: 7778

JOB# 1 CHARGES-----

LABOR-----

CUST STATES AT HIGHWAY SPEED LET GO OF WHEEL PULLS TO LEFT
 ROAD TEST VECHILE VERFIY CONCERN ALIGN FT END RESET
 CAMBER, CASTER AND TOE

JOB# 1 TOTALS-----

JOB# 1 JOURNAL PREFIX FTCS JOB# 1 TOTAL 0.00

JOB# 2 CHARGES-----

LABOR-----

CUST STATES WHEN LETTING OFF ACCLERATOR AT 2000 RPH IDLE
 DROP REAL QUICK
 PERFORM ENGINE DAIG UNABLE TO VERFIY CONCERN AT THIS TIME

JOB# 2 TOTALS-----

JOB# 2 JOURNAL PREFIX FTCS JOB# 2 TOTAL 0.00

JOB# 3 CHARGES-----

LABOR-----

CUST STATES CK FOR TICKING NOISE IN ENGINE AREA WHEN FIRST
 STARTING UP GOES AWAY WHEN WARMED UP
 UNABLE TO VERFIY CONCERN

JOB# 3 TOTALS-----

JOB# 3 JOURNAL PREFIX FTCS JOB# 3 TOTAL 0.00

Reynolds and Reynolds, ENALZBNVIE 0017187 Q (04/09)



MEADOWLAND FORD TRUCK SALES INC.

330 County Avenue
Secaucus, New Jersey 07096

SALES: (201) 617-0700 FAX: (201) 617-9843
 Mon. thru Fri. 8 to 6; Sat. 9 to 1
 SERVICE: (201) 617-5577
 Mon thru Fri. 7:30 - 7:00 Sat. 8:00 - 3:00
 PARTS: (201) 617-5200 FAX: (201) 617-9793
 Mon. thru Fri. 7:30 - 7:00 Sat. 8:00 - 12:00

Called

CELL: [REDACTED]

CUSTOMER NO. 28025	ADVISOR JAMES ROSE	14014	TAG NO. 9038	INVOICE DATE 06/10/10	STOCK NO. FTCS195611
[REDACTED]	LABOR RATE 108.00	LICENSE NO.	MILEAGE 33,511	COLOR OXFORD WHIT	STOCK NO. 1293
BAYONNE, NJ	YEAR / MAKE / MODEL 08/FORD TRUCK/F350/TRK CREW CAB SRW			DELIVERY DATE 07/02/09	DELIVERY MILES 39
	VEHICLE I.D. NO. 1 F T W W 3 1 R 2 8 E			SELLING DEALER NO.	PRODUCTION DATE
	F.T.E. NO.	P.O. NO.	R.O. DATE 06/07/10		
COMMENTS					MO: 33516

JOB# 1 CHARGES

LABOR
 # 1 45FTZ12 P/S FLUID LEAK HOURS: TECH(S): 4014 WARRANTY
 CUSTOMER STATES POWER STEERING FLUID LEAKING
 OR TRANS FLUID LEAKING NEAR PS PUMP
 FT END WANDERS THE DRIVING
 ROAD TEST VEHICLE - CK - TRANS OPERATION CK FLUID PERFORM EEC
 TEST PCM AND TCM PASSED. CK FT SUSPENSION FOUND STEERING BOX
 BINDING WHEN TURNING WHEEL. BOX AND STEERING DAMPER ALSO
 LEAKING. REPLACE STEERING BOX AND DAMPER REROAD TEST TRUCK

PARTS	QTY	FP NUMBER	DESCRIPTION	UNIT PRICE	WARRANTY
	1	8C3Z-3504-CRM	GEAR ASY 1 474769		WARRANTY
	1	8C3Z-3E651-E	DAMPER A 1 284166		WARRANTY
TOTAL - PARTS					0.00

JOB# 1 TOTALS
 JOB# 1 JOURNAL PREFIX FTCS JOB# 1 TOTAL 0.00

JOB# 2 CHARGES

LABOR
 # 2 13FTZ ENGINE DIESEL HOURS: TECH(S): 4014 0.00
 CUST STATES AT 35-40 MPH GETS AIR NOISE POSSIBLY NEAR TURBO
 UNABLE TO VERIFY CONCERN

JOB# 2 TOTALS
 JOB# 2 JOURNAL PREFIX FTCS JOB# 2 TOTAL 0.00

JOB# 3 CHARGES

LABOR
 # 3 30FTZ AUTO TRANSMISSION HOURS: TECH(S): 4014 0.00
 CUST STATES TRANS CHATTERS WHEN TOWING
 UNABLE TO VERIFY CONCERN

JOB# 3 TOTALS
 JOB# 3 JOURNAL PREFIX FTCS JOB# 3 TOTAL 0.00

JOB# 4 CHARGES

LABOR
 # 4 60FTZ18 ARM RESTS HOURS: TECH(S): 4014 WARRANTY
 CUST STATES CENTER ARMREST CLICKS AND FEELS LOOSE
 REPLACE CENTER ARMREST

PARTS	QTY	FP NUMBER	DESCRIPTION	UNIT PRICE	WARRANTY
	1	8C3Z-2560136-AC	BACK ASY 1 260132		0.00
TOTAL - PARTS					0.00

JOB# 4 TOTALS
 JOB# 4 JOURNAL PREFIX FTCS JOB# 4 TOTAL 0.00

The Reynolds and Reynolds Company EPALZTRNVE C0317167 0 (04/09)



MEADOWLAND FORD TRUCK SALES INC.

330 County Avenue
Secaucus, New Jersey 07096

SALES: (201) 617-0700 FAX: (201) 617-9843
 Mon. thru Fri. 8 to 6; Sat. 9 to 1
 SERVICE: (201) 617-5577
 Mon thru Fri. 7:30 - 7:00 Sat. 8:00 - 3:00
 PARTS: (201) 617-5200 FAX: (201) 617-9793
 Mon. thru Fri. 7:30 - 7:00 Sat. 8:00 - 12:00

Called

CELL: [REDACTED]

CUSTOMER NO. 28025	ADVISOR MICHAEL COAKLEY	2552	TAG NO. 9210	INVOICE DATE 06/23/10	FTCS 155700
[REDACTED]	LABOR RATE 108.00	LICENSE NO.	MILEAGE 34,637	COLOR OXFORD WHIT	STOCK NO. 1293
BAYONNE, NJ	YEAR / MAKE / MODEL 08 / FORD TRUCK / F350 / TRK CREW CAB SRW			DELIVERY DATE 07/02/09	DELIVERY MILES 39
[REDACTED]	VEHICLE I.D. NO. 1 F T W W 3 1 R 2 8 E			SELLING DEALER NO.	PRODUCTION DATE
[REDACTED]	F.T.E. NO.	P.O. NO.	R.O. DATE 06/21/10		
COMMENTS					MO: 34640

JOB# 1 CHARGES-----
 LABOR-----
 JOB# 1 45FTZ01 STEERING CONCERN HOURS: TECH(S):9945 0.00
 CUST STATES CK FT END VEHICLE GOES ALL OVER THE ROAD
 CK FT SUSPENSION RESET TIRE PRESSURE ROTATE TIRES
 RESET TOE ROAD TEST TRUCK

JOB# 1 TOTALS-----
 JOB# 1 JOURNAL PREFIX FTCS JOB# 1 TOTAL 0.00

JOB# 2 CHARGES-----
 LABOR-----
 JOB# 2 30FTZZ AUTO TRANS CONCERN HOURS: TECH(S):9945 0.00
 CUST STATES CK TRANS OPERATIO GETTING CHATTER UNDER LOAD GO
 ING UP HILLS
 PERFORM EEC TEST CK FOR CODES HAS NO ACTIVE CODES STORED
 ROAD TEST VEHICLE UNABLE TO VERIFY CONCERN

JOB# 2 TOTALS-----
 JOB# 2 JOURNAL PREFIX FTCS JOB# 2 TOTAL 0.00

TOTALS-----

 [] CASH [] CHECK CK NO. [] *
 [] VISA [] MASTERCARD *
 [] AMEX [] CHARGE *

 TOTAL LABOR.... 0.00
 TOTAL PARTS.... 0.00
 TOTAL SUBLET... 0.00
 TOTAL G.O.G.... 0.00
 TOTAL MISC CHG. 0.00
 TOTAL MISC DISC 0.00
 TOTAL TAX..... 0.00
 TOTAL INVOICE \$ 0.00

THANK YOU FOR YOUR BUSINESS!!

PLEASE PRINT NAME

 CUSTOMER SIGNATURE

The Reynolds and Reynolds Company ERAL/PRIME CC317187 O (04/08)



MEADOWLAND FORD TRUCK SALES INC.

330 County Avenue
Secaucus, New Jersey 07096

SALES: (201) 617-0700 FAX: (201) 617-9843
 Mon. thru Fri. 8 to 6; Sat. 9 to 1
 SERVICE: (201) 617-5577
 Mon thru Fri. 7:30 - 7:00 Sat. 8:00 - 3:00
 PARTS: (201) 617-5200 FAX: (201) 617-9793
 Mon. thru Fri. 7:30 - 7:00 Sat. 8:00 - 12:00

Called

CELL: [REDACTED]

CUSTOMER NO. 28025	ADVISOR MICHAEL COAKLEY	2552	TAG NO. 9455	INVOICE DATE 08/10/10	FTCS 196116
[REDACTED]	LABOR RATE 108.00	LICENSE NO.	MILEAGE 35,289	COLOR OXFORD WHIT	STOCK NO. 1293
BAYONNE, NJ	YEAR / MAKE / MODEL 08/FORD TRUCK/F350/TRK CREW CAB SRW	VEHICLE I.D. NO. 1FTWW31R28E		DELIVERY DATE 07/02/09	DELIVERY MILES 39
[REDACTED]	F.T.E. NO.	P. O. NO.	R.O. DATE 08/03/10	SELLING DEALER NO.	PRODUCTION DATE
COMMENTS					MO: 35291

LABOR
 # 1 10FTZ06 CHECK ENGINE LIGHT HOURS TECH(S) 9945 WARRANTY
 CUSTOMER STATES CHECK ENGINE LIGHT ON
 PERFORM ENGINE DIAG REPROGRAM CONTROL MODULES ROAD TEST PIN
 POINT TEST FOUND EGT SENOSR OUT OF SPEC REPLACE SENSOR
 CLEAR SYSTEM RETEST ROAD TEST TRUCK

JOB# 1 TOTALS-----
 JOB# 1 JOURNAL PREFIX FTCS JOB# 1 TOTAL 0.00

JOB# 2 CHARGES-----

LABOR
 # 2 45FTZ STEERING/SUSPENSION HOURS TECH(S) 9945 INTERNAL
 CUST STATES CK STEERING AND SUSPENSION VEHICLE PULLS TO LEFT
 INSTALL CAMBER BUSHING RESET CAMBER, CASTER, TOE ROAD TEST
 TRUCK OK.

PARTS-----QTY---FP-NUMBER-----DESCRIPTION-----UNIT PRICE-----INTERNAL
 2 5C3Z-3B440-EEE ADJUSTER 2 120684 TOTAL - PARTS 0.00

JOB# 2 TOTALS-----
 JOB# 2 JOURNAL PREFIX FTCS JOB# 2 TOTAL 0.00

JOB# 3 CHARGES-----

LABOR
 # 3 60FTZ08 CONSOLE HOURS TECH(S) 9945 0.00
 CUST STATES ARM REST MAKING CLICKING NOISE WHILE DRIVING
 UNABLE TO VERIFY CONCERN

JOB# 3 TOTALS-----
 JOB# 3 JOURNAL PREFIX FTCS JOB# 3 TOTAL 0.00

JOB# 4 CHARGES-----

LABOR
 # 4 05FTZ19 TIRE ROTATION HOURS TECH(S) 9945 0.00
 CUSTOMER REQUESTS TIRE ROTATION
 CUSTOMER REQUESTS TIRE ROTATION
 PERFORMED TIRE ROTATION

JOB# 4 TOTALS-----
 JOB# 4 JOURNAL PREFIX FTCS JOB# 4 TOTAL 0.00

JOB# 5 CHARGES-----

LABOR
 # 5 20FTZ02 COOLING SYSTEM HOURS TECH(S) 9945 WARRANTY
 CUST STATES CK FAN SHROULD CRACKING
 CK SHROUD FOUND CRACKING REPLACE SHROUD

The Reynolds and Reynolds Company ERALZERRIVE C0217187 0 (04/09)

All Action Details for Issue

[Print](#)

VIN: 1FTWW31R28F [REDACTED] Year: 2008 Model: F-SERIES SUPER DUTY Case: 581251740
 Name: [REDACTED] Owner Status: Original WSD: 2009-07-02
 Symptom Desc: STRG/HANDLING PULL/DRIFT LEFT Primary Phone: [REDACTED]
 Reason Desc: SUPER DUTY-ECONOLINE Secondary Phone: [REDACTED]
 Issue Type: 04 REGION Issue Status: CLOSED
 Initial Customer Contact: 08/12/2010

Action: SD - AT RISK MULTIPLE REPAIRS

Dealer: 03714 MEADOWLANDFORD TRUCK SALES, INC. Origin Desc: CRC TIER ONE - SUPER DUTY E-SERIES
 Odometer: 39000 MI Comm Type: PHONE
 Analyst Name: GREEN Analyst: PGREEN76
 (PGREEN76),PATRICIA
 Action Date: 08/11/2010 Action Time: 10.59.15.016 Action Data: No

Comments CUSTOMER SAID: -CUST CALLING BACK BECAUSE HE SAYS THE TRUCK HAS THE SAME PROBLEM.- VEH PULLS TO THE LEFT.-CUST SAYS VEH HAS BEEN INTO DLR FOR A TOTAL OF 6 TIMES.8/2/10. DLR SAID PROBLEM WAS FIXED BUT THEY WERE WAITING ON OXYGEN SENSOR AND VEH WOULD BE READY 8/10/10.8/10/10 - CUST PICKED UP THE VEHICLE AND WAS ASSURED IT WAS FIXED.-CUST SAID THE PROBLEM IS STILL THERE.-CUST SAID THE ARMREST WAS BROKEN AND DLR STILL HASN'T BEEN FIXED.-CUST SAID DLR KEEPS TELLING HIM TO BRING IT BACK AND HE IS TIRED OF BRINGING IT BACK.DEALER SAID: MEADOWLAND FORD TRUCK SALES INC.330 COUNTY AVENUESECAUCUS, NJ 07094TEL:(201) 617-0700CRC ADVISED: I WILL ESCALATE THIS TO OUR CUSTOMER CARE SOLUTIONS TEAM. A SPECIALIST WILL CONTACT YOU WITHIN 1 BUSINESS DAY.VEH WITH CUSTCALL CUST ANYTIME DURING THE DAY AT [REDACTED]

Action: CCS FOLLOW UP W/CUSTOMER - DOC ADDITIONAL INFORMATION

Dealer: 03714 MEADOWLANDFORD TRUCK SALES, INC. Origin Desc: CUSTOMER CARE SOLUTIONS TEAM
 Odometer: 39000 MI Comm Type: PHONE
 Analyst Name: RONDA,MARIO Analyst: MRONDA
 Action Date: 08/12/2010 Action Time: 10.56.07.347 Action Data: Yes

Comments CCS MARIO X723REVIEW CASE- ESP 48/100 EXTERACARE, NO ESP RECALLS, AWS- SUSPENSION PULLS TO LEFT, ENGINE LEAKING OIL, POWER STEERING LEAKING OIL. NO HOTLINE, LTV 85-OBC TO DLR S/A MIKE HE ADVISED REP THAT HE HAS PERFORMED SEVERAL ALIGNMENTS ON THIS VEH ALL ACCORDING TO SPEC. -THE TIRES HAVE BEEN ROTATED AND BALANCED-S/A ADVISED REP THAT THE TIRES ARE IN EXCELLENT CONDITION-3 DIFFERENT S/A HAVE DRIVEN THE VEH UNDER THE SAME CONDITION AS THE CUST STATES HE DRIVES IT AND HAVE NOT BEEN ABLE TO DUPLICATE THE PROBLEM.-OBC TO CUST [REDACTED] CUST UPSET HE HAS HAD HIS VEH IN FOR THE SAME REPAIR 6 TIMES-CUST CLAIMS HE DROVE ANOTHER TRUCK LIKE HIS AND IT DOES NOT HAVE THE SAME PROBLEM-CUST WANTS S/M JIM ROSE TO DRIVE THE VEH WITH HIM SO HE CAN SHOW HIM THE PROBLEM WITH THE VEH-REP ADVISED CUST THAT I WOULD CONTACT S/M AND HAVE HIM CALL YOU TO SET AN APPOINTMENT TO TEST DRIVE THE VEH.-REP WILL F/U WITH CUST ON 8/17/10 BEFORE 5PM ET-REP CONTACTED S/M JIM ROSE AND PROVIDED CONTACT INFORMATION FOR HIM TO CALL CUST [REDACTED]

Data Element Name	Data Value
DATE OF FOLLOW UP:	08-17-2010
TIME OF FOLLOW UP (HH:MM):	18:00

Action: CCS FOLLOW UP W/CUSTOMER - DOC ADDITIONAL INFORMATION

Dealer: 03714 MEADOWLANDFORD TRUCK SALES, INC. Origin Desc: CUSTOMER CARE SOLUTIONS TEAM
 Odometer: 39000 MI Comm Type: PHONE

Analyst Name: RONDA,MARIO **Analyst:** MRONDA
Action Date: 08/17/2010 **Action Time:** 14.10.27.240 **Action Data:** Yes

Comments OBC TO CUST [REDACTED] REP ASKED IF HE WAS ABLE TO SET AN APPOINTMENT WITH THE DLR, CUST STATED HE WAS UNHAPPY WITH THE RESPONSE HE RECEIVED FROM THE DLR.CUST WANTS TO PURSUE LEGAL ACTION REGARDING THIS CASE. REP SUGGESTED TAKING VEH TO ANOTHER DLR FOR A SECOND OPINION TO SEE IF THE ISSUE COULD BE RESOLVED. CUST WILL TRY TO MAKE AN APPOINTMENT WITH OTHER DLR. REP WILL F/U WITH CUST ON 8/18/10 BEFORE 5PM ET.

Data Element Name	Data Value
DATE OF FOLLOW UP:	08-18-2010
TIME OF FOLLOW UP (HH:MM):	18:00

Action: CCS FOLLOW UP W/CUSTOMER - DOC ADDITIONAL INFORMATION
Dealer: 03714 MEADOWLANDFORD TRUCK SALES, INC. **Origin Desc:** CUSTOMER CARE SOLUTIONS TEAM
Odometer: 39000 MI **Comm Type:** PHONE
Analyst Name: RONDA,MARIO **Analyst:** MRONDA
Action Date: 08/18/2010 **Action Time:** 12.49.35.945 **Action Data:** Yes

Comments OBC TO CUST [REDACTED] CUST ADVISED REP HE IS MAKING AN APPOINTMENT FOR A SECOND OPINION ON HIS VEH. CUST WANT REP TO F/U WITH HIM ON 8/26/10 BEFORE 5 PMET.

Data Element Name	Data Value
DATE OF FOLLOW UP:	08-26-2010
TIME OF FOLLOW UP (HH:MM):	18:00

Action: CCS FOLLOW UP W/CUSTOMER - DOC ADDITIONAL INFORMATION
Dealer: 03714 MEADOWLANDFORD TRUCK SALES, INC. **Origin Desc:** CUSTOMER CARE SOLUTIONS TEAM
Odometer: 39000 MI **Comm Type:** PHONE
Analyst Name: RONDA,MARIO **Analyst:** MRONDA
Action Date: 08/26/2010 **Action Time:** 11.10.23.007 **Action Data:** Yes

Comments OBC TO CUST [REDACTED] NO ANSWER LEFT V/M WILL F/U ON 9/30/10 BEFORE 5 PM ET.

Data Element Name	Data Value
DATE OF FOLLOW UP:	09-30-2010
TIME OF FOLLOW UP (HH:MM):	18:00

Action: CONCERN ADDRESSED
Dealer: 03714 MEADOWLANDFORD TRUCK SALES, INC. **Origin Desc:** CUSTOMER CARE SOLUTIONS TEAM
Odometer: 39000 MI **Comm Type:** PHONE
Analyst Name: RONDA,MARIO **Analyst:** MRONDA
Action Date: 08/30/2010 **Action Time:** 14.56.18.193 **Action Data:** Yes

Comments OBC TO CUST [REDACTED] CUST ADVISED REP HE TOOK VEH TO ANOTHER DLR TO GET SECOND OPINION AND WAS TOLD THAT THEY WOULD NOT DO REPAIRS BECAUSE HE HAS BEEN DEALING WITH MEADOWLAND FORD. CUST WANT TO CONTACT DEALER AND SPEAK WITH OWNER. UNABLE TO DUPLICATE PROBLEM NO FURTHER ACTION REQUIRED CASE CLOSED.

Data Element Name	Data Value
CUSTOMER'S LTV SCORE	85
PARTS ESCALATION USED? (Y/N)	N

TECH ASSIST (FSE INVOLVED) USED? (Y/N)	N
TECH HOTLINE CONSULTED? (Y/N)	N
ESP USED? (Y/N)	N
SCP USED? (Y/N)	N
X-PLAN USED? (Y/N)	N
CLP FINANCIAL ASSIST PROVIDED? (Y/N)	N
--ESTIMATED REPAIR COST(@WARR RATES) (\$)	
--CUSTOMER'S SHARE OF REPAIR COST (\$)	
--DEALER'S SHARE OF REPAIR COST-P18 (\$)	
--DEALER'S SHARE OF REPAIR COST-OTHER(\$)	
--FORDS'S SHARE OF REPAIR COST-P11 (\$)	
CLP FINANCIAL ASSIST DENIED? (Y/N)	N
NONE OF THE ABOVE (Y/N)	Y

Ford Confidential

All Action Details for Issue

[Print](#)

VIN: 1FTWW31R28E [REDACTED] Year: 2008 Model: F-SERIES SUPER DUTY Case: 581251740
Name: [REDACTED] Owner Status: Original WSD: 2009-07-02
Symptom Desc: STRG/HANDLING PULL/DRIFT LEFT Primary Phone: [REDACTED]
Reason Desc: CLP - IN - SERVICE REPAIR - AT RISK Secondary Phone: [REDACTED]
Issue Type: 04 REGION Issue Status: CLOSED
Initial Customer Contact: 06/24/2010

Action: TIER II ESCALATION - UNABLE TO DUPLICATE
Dealer: 03714 MEADOWLAND FORD TRUCK SALES, INC. Origin Desc: US CONCERN CASE BASE
Odometer: 33000 MI Comm Type: PHONE
Analyst Name: RASZIPOVITS, ROBERTA Analyst: RRASZIPO
Action Date: 06/23/2010 Action Time: 16.19.14.934 Action Data: No

Comments CUSTOMER SAID: -VEH WILL PULL TO THE LEFT.-NOISE IN THE TRANSMISSION WHEN TOWING.-TOOK VEH TO THE DLRSH. NOT ABLE TO DUPLICATE CONCERN. -BEEN TO THE DLRHSP SEVERAL ISSUES.-VEH IS CURRENTLY AT THE DLRSH.-WANTS TO HAVE CONCERN DOCUMENTED.-WANTS VEH REPAIRED.DEALER SAID: MEADOWLAND FORD TRUCK SALES INC.330 COUNTY AVENUE SECAUCUS, NJ 07094 TEL:(201) 617-0700 CRC ADVISED: I WILL ESCALATE THIS TO OUR CUSTOMER CARE SOLUTIONS TEAM. A SPECIALIST WILL CONTACT YOU WITHIN 2 BUSINESS DAYS.***NOTE TO CCR: IF THE VEHICLE IS CURRENTLY NOT AT THE DEALERSHIP, PLEASE ADVISE THE CUSTOMER TO SCHEDULE A SERVICE APPOINTMENT FOR THEIR VEHICLE.-ADV OF ABOVE.-ADV CUST THAT THE LEMON LAW IS DIFFERENT FOR EACH STATE AND WOULD HAVE TO GO TO THE LOCAL LIBRARY FOR MORE INFORMATION.***CONTACT INFORMATION:-CUST IS AVAILABLE ANY TIME OF DAY.-CONTACT CUST ON THE CELL [REDACTED]

Action: DOCUMENT ADDITIONAL INFORMATION
Dealer: 03714 MEADOWLAND FORD TRUCK SALES, INC. Origin Desc: CUSTOMER CARE SOLUTIONS TEAM
Odometer: 33000 MI Comm Type: OTHER
Analyst Name: MCCAULEY, ERIN Analyst: EMCCAUL3
Action Date: 06/24/2010 Action Time: 09.14.26.988 Action Data: No

Comments CCS ERIN EXT 7193 - CASE RESEARCH - LTV SCORE 84 - STEERING / TRANS NOISE - 1 ORIGINAL OWNER OUT OF 2 - 48 \ 100K EXTRACARE ESP 'S -- NO GCQIS REPORTS - 2 AWS FOR PULL TO LEFT / 1 AWS FOR POWER STEERING OR TRANS FLUID LEAK - CUST SEEKING REPAIR

Action: CCS FOLLOW UP W/CUSTOMER - DOC ADDITIONAL INFORMATION
Dealer: 03714 MEADOWLAND FORD TRUCK SALES, INC. Origin Desc: CUSTOMER CARE SOLUTIONS TEAM
Odometer: 33000 MI Comm Type: PHONE
Analyst Name: MCCAULEY, ERIN Analyst: EMCCAUL3
Action Date: 06/24/2010 Action Time: 13.56.18.661 Action Data: Yes

Comments CCS ERIN EXT 7193 -- OBC TO DLR SM JIM ROSE @ 201-617-0700 -- ADVISED THE ONLY THING CAN RECOMMEND HAVE THE CUST GO ON TEST DRIVE WITH DLR AND PINPOINT NOISE HE IS ADVISING OF AS DLR HAS NOT BEEN ABLE TO DUPLICATE ----- OBC TO [REDACTED] LEFT VM VERIFIED 2008 F-350 (DIESEL) W/ 33000 MILES ASSIGNED TO MEADOWLAND FORD TRUCK SALES FOR STEERING / TRANS NOISE CONCERN : ADVISED CCS IS HERE TO BE A LIAISON BETWEEN IND OWNED DLR AND CUST TO MAKE SURE ALL AVAILABLE RESOURCES ARE UTILIZED TO ADDRESS ANY MANUFACTURING DEFECT AS SOON AS POSSIBLE ; PROVIDED CONTACT NUMBER OF 866-631-3788 EXT 7193 ; CASE NUMBER [REDACTED] -- ADVISED RECOMMEND DOING TEST DRIVE WITH THE DLR TO CONFIRM THE CONCERN AS FMC CANNOT DO A REPAIR UNTIL THE CONCERN IS DUPLICATED FOR THE DLRSH AND WILL FU ON 6/25 BY 18:00 ----- OBC TO [REDACTED] - CUST ADVISED A FRIEND ADVISED CALL THE CRC AND MAKE IT KNOWN THERE IS A PROBLEM \ HAVE TAKEN TO DLR 4 TIMES TO THE DLR AND THE VEH IS STILL DOING THE SAME THING -- CUST ADVISED PICKED UP THE VEH LAST NIGHT AND DOING THE SAME THING -- THE SERVICE MANAGER AND SALES MANAGER ARE ALL SAYING THE SAME THING AND THE TECH IS SAYING THIS IS NORMAL

-- CUST ADVISED WHEN PULLING TRAILER GOING UPHIL ON OCCASION -- CUST ADVISED HIS MAIN CONCERN IS THE PULLING TO THE LEFT -- CUST ADVISED THE DLR SERVICE IS TRYING TO SAY IS NORMAL AND SPOKE WITH THE DLR BUSINESS MANAGER MATT WHO IS A FRIEND AND HE ADVISED HE WILL TAKE CARE OF GETTING THIS ADDRESSED THRU THE SM AND WILL CALL BACK -- CCS ADVISED THAT CCS WORKS WITH THE SM AND AT THIS TIME IS RECOMMENDING A TEST DRIVE TO DETERMINE IF THERE IS A CONCERN AND ADVISED DO NOT WISH TO WAIT TO ADDRESS THE TRANS NOISE AS IF THAT IS HARD TO DUPLICATE DO NOT WANT TO WAIT UNTIL THE WARRANTY IS OUT -- CUST ADVISED IF NEEDED WILL PUT THE TRAILER AND RACE VEH ON BACK OF VEH AND DRIVE THE 100 MILES TO THE DLR AND THEN FIND A HILL TO ATTEMPT TO DUPLICATE THE CONCERN -- CUST ADVISED HE IS WAITING ON CALL FROM MATT AND WILL THEN CONTINUE WITH RECOMMENDATIONS -- CCS ADVISED WILL FU ON 6/29 BY 18:00

Data Element Name	Data Value
DATE OF FOLLOW UP:	06-29-2010
TIME OF FOLLOW UP (HH:MM):	18:00

Action: CUSTOMER DOES NOT WISH TO ADDRESS AT THIS TIME
Dealer: 03714 MEADOWLANDFORD TRUCK SALES, INC. **Origin Desc:** CUSTOMER CARE SOLUTIONS TEAM
Odometer: 33000 MI **Comm Type:** PHONE
Analyst Name: MCCAULEY,ERIN **Analyst:** EMCCAUL3
Action Date: 06/29/2010 **Action Time:** 14.40.33.691 **Action Data:** No

Comments OBC TO DLR SM JIM ROSE @ 201-617-0700 -- ADVISED THE VEH IS SUPPOSE TO COME BACK TO HAVE TECH RIDE WITH HIM AGAIN AS WAS NOT ABLE TO DUPLICATE THE NOISE AND DLR LIKE TO ADDRESS THE CONCERN ----- OBC TO [REDACTED] -- SPOKE WITH MATT AND WAS SUPPOSE TO MAKE APPT AT THE DLR BUT GETTING READY TO GO AWAY ON BUSINESS ON JULY 3 TIL JULY 16 AND WILL BE TAKING THE TRUCK AND ADDRESSING WHEN GET BACK -- CCS ADVISED AS HE IS GOING AWAY WILL CLOSE CASE AND ADVISED WILL SEND EMAIL WITH CONTACT INFO AND WHEN GET BACK AND READY TO ADDRESS THE PULL TO CONTACT THE DLR AND IF STILL NEED CCS TO PLEASE EMAIL WITH THE CASE NUMBER AND WILL RE-OPEN AND SEE IF ANYTHING WE CAN DO TO ASSIST BUT WILL MAKE NO PROMISES -- CUST AGREES -- CUST PROVIDED EMAIL OF [REDACTED] ----- EMAIL SENT TO CUST -- NFA

Ford Confidential



MEADOWLAND FORD TRUCK SALES INC.

330 County Avenue
Secaucus, New Jersey 07096

SALES: (201) 617-0700 FAX: (201) 617-9843
 Mon. thru Fri. 8 to 6; Sat. 9 to 1
 SERVICE: (201) 617-5577
 Mon thru Fri. 7:30 - 7:00 Sat. 8:00 - 3:00
 PARTS: (201) 617-5200 FAX: (201) 617-9793
 Mon. thru Fri. 7:30 - 7:00 Sat. 8:00 - 12:00

Called

CELL: [REDACTED]

CUSTOMER NO. 28025	ADVISOR MICHAEL COAKLEY	2552	TAG NO. 7222	INVOICE DATE 09/15/09	INVOICE NO. FTCS193122
[REDACTED]	LABOR RATE 108.00	LICENSE NO.	MILEAGE 7,774	COLOR OXFORD WHIT	STOCK NO. 1293
BAYONNE, NJ	YEAR / MAKE / MODEL 08/FORD TRUCK/F350/TRK CREW CAB SRW			DELIVERY DATE 07/02/09	DELIVERY MILES 39
	VEHICLE I.D. NO. 1FTWW31R28E			SELLING DEALER NO.	PRODUCTION DATE
RESIDENCE PHONE	BUSINESS PHONE	COMMENTS		R.O. DATE 09/14/09	
[REDACTED]	[REDACTED]				MO: 7778

JOB# 1 CHARGES-----

LABOR-----

1 45FTZ03 SUSPENSION CONCERN HOURS TECH(S) 24572 WARRANTY
 CUST STATES AT HIGHWAY SPEED LET GO OF WHEEL PULLS TO LEFT
 ROAD TEST VEHICLE VERIFY CONCERN ALIGN FT END RESET
 CAMBER, CASTER AND TOE

JOB# 1 TOTALS-----

JOB# 1 JOURNAL PREFIX FTCS JOB# 1 TOTAL 0.00

JOB# 2 CHARGES-----

LABOR-----

2 13F7Z ENGINE DIESEL HOURS TECH(S) 24572 0.00
 CUST STATES WHEN LETTING OFF ACCLERATOR AT 2000 RPH IDLE
 DROP REAL QUICK
 PERFORM ENGINE DAIG UNABLE TO VERIFY CONCERN AT THIS TIME

JOB# 2 TOTALS-----

JOB# 2 JOURNAL PREFIX FTCS JOB# 2 TOTAL 0.00

JOB# 3 CHARGES-----

LABOR-----

3 12FTZ04 ENGINE NOISE HOURS TECH(S) 24572 0.00
 CUST STATES CK FOR TICKING NOISE IN ENGINE AREA WHEN FIRST
 STARTING UP GOES AWAY WHEN WARMED UP
 UNABLE TO VERIFY CONCERN

JOB# 3 TOTALS-----

JOB# 3 JOURNAL PREFIX FTCS JOB# 3 TOTAL 0.00

Reynolds and Reynolds EDALZRNVE CB7187 O (04/09)



MEADOWLAND FORD TRUCK SALES INC.

330 County Avenue
Secaucus, New Jersey 07096

SALES: (201) 617-0700 FAX: (201) 617-9843
 Mon. thru Fri. 8 to 6; Sat. 9 to 1
 SERVICE: (201) 617-5577
 Mon thru Fri. 7:30 - 7:00 Sat. 8:00 - 3:00
 PARTS: (201) 617-5200 FAX: (201) 617-9793
 Mon. thru Fri. 7:30 - 7:00 Sat. 8:00 - 12:00

Called

CELL: [REDACTED]

CUSTOMER NO. 28025	ADVISOR JAMES ROSE	14014	TAG NO. 9038	INVOICE DATE 06/10/10	INVOICE NO. FTCS195611
[REDACTED]	LABOR RATE 108.00	LICENSE NO.	MILEAGE 33,511	COLOR OXFORD WHIT	STOCK NO. 1293
BAYONNE, NJ	YEAR / MAKE / MODEL 08/FORD TRUCK/F350/TRK CREW CAB SRW			DELIVERY DATE 07/02/09	DELIVERY MILES 39
	VEHICLE I.D. NO. 1 F T W W 3 1 R 2 8 E			SELLING DEALER NO.	PRODUCTION DATE
	F.T.E. NO.			DATE 06/07/10	
	COMMENTS				MO: 33516

JOB# 1 CHARGES-----

LABOR-----
 J# 1 45FTZ12 P/S FLUID LEAK HOURS: TECH(S):4014 WARRANTY
 CUSTOMER STATES POWER STEERING FLUID LEAKING
 OR TRANS FLUID LEAKING NEAR PS PUMP
 FT END WANDERS THE DRIVING
 ROAD TEST VEHICLE CK TRANS OPERATION CK FLUID PERFORM EEC
 TEST PCM AND TCM PASSED. CK FT SUSPENSION FOUND STEERING BOX
 BINDING WHEN TURNING WHEEL. BOX AND STEERING DAMPER ALSO
 LEAKING. REPLACE STEERING BOX AND DAMPER REROAD TEST TRUCK

PARTS	QTY	FP-NUMBER	DESCRIPTION	UNIT PRICE	WARRANTY
	1	8C3Z-3504-CRM	GEAR ASY 1 474769		WARRANTY
	1	8C3Z-3E651-E	DAMPER A 1 284166		WARRANTY
TOTAL - PARTS					0.00

JOB# 1 TOTALS-----
 JOB# 1 JOURNAL PREFIX FTCS JOB# 1 TOTAL 0.00

JOB# 2 CHARGES-----
 LABOR-----
 J# 2 13FTZ ENGINE DIESEL HOURS: TECH(S):4014 0.00
 CUST STATES AT 35-40 MPH GETS AIR NOISE POSSIBLY NEAR TURBO
 UNABLE TO VERIFY CONCERN

JOB# 2 TOTALS-----
 JOB# 2 JOURNAL PREFIX FTCS JOB# 2 TOTAL 0.00

JOB# 3 CHARGES-----
 LABOR-----
 J# 3 30FTZ AUTO TRANSMISSION HOURS: TECH(S):4014 0.00
 CUST STATES TRANS CHATTERS WHEN TOWING
 UNABLE TO VERIFY CONCERN

JOB# 3 TOTALS-----
 JOB# 3 JOURNAL PREFIX FTCS JOB# 3 TOTAL 0.00

JOB# 4 CHARGES-----
 LABOR-----
 J# 4 60FTZ18 ARM RESTS HOURS: TECH(S):4014 WARRANTY
 CUST STATES CENTER ARMREST CLICKS AND FEELS LOOSE
 REPLACE CENTER ARMREST

PARTS	QTY	FP-NUMBER	DESCRIPTION	UNIT PRICE	WARRANTY
	1	8C3Z-2560136-AC	BACK ASY 1 260132		WARRANTY
TOTAL - PARTS					0.00

JOB# 4 TOTALS-----
 JOB# 4 JOURNAL PREFIX FTCS JOB# 4 TOTAL 0.00

The Reynolds and Reynolds Company ERALZRNIVE GC217187 O. 00499



MEADOWLAND FORD TRUCK SALES INC.

330 County Avenue
Secaucus, New Jersey 07096

SALES: (201) 617-0700 FAX: (201) 617-9843
 Mon. thru Fri. 8 to 6; Sat. 9 to 1
 SERVICE: (201) 617-5577
 Mon thru Fri. 7:30 - 7:00 Sat. 8:00 - 3:00
 PARTS: (201) 617-5200 FAX: (201) 617-9793
 Mon. thru Fri. 7:30 - 7:00 Sat. 8:00 - 12:00

Called

CELL: [REDACTED]

CUSTOMER NO. 28025	ADVISOR MICHAEL COAKLEY	2552	TAG NO. 9210	INVOICE DATE 06/23/10	INVOICE NO. FTCS195760
[REDACTED]	LABOR RATE 108.00	LICENSE NO.	MILEAGE 34,637	COLOR OXFORD WHIT	STOCK NO. 1293
BAYONNE, NJ	YEAR / MAKE / MODEL 08/FORD TRUCK/F350/TRK CREW CAB SRW			DELIVERY DATE 07/02/09	DELIVERY MILES 39
	VEHICLE I.D. NO. 1 F T W W 3 1 R 2 8 E		[REDACTED]	SELLING DEALER NO.	PRODUCTION DATE
	F.T.E. NO.			R.O. DATE 06/21/10	
	COMMENTS				MO: 34640

JOB# 1 CHARGES-----

LABOR-----
 J# 1 45FTZ01 STEERING CONCERN HOURS: TECH(S):9945 0.00
 CUST STATES CK FT END VEHICLE GOES ALL OVER THE ROAD
 CK FT SUSPENSION RESET TIRE PRESSURE ROTATE TIRES
 RESET TOE ROAD TEST TRUCK

JOB# 1 TOTALS-----

JOB# 1 JOURNAL PREFIX FTCS JOB# 1 TOTAL 0.00

JOB# 2 CHARGES-----

LABOR-----
 J# 2 30FTZZ AUTO TRANS CONCERN HOURS: TECH(S):9945 0.00
 CUST STATES CK TRANS OPERATIO GETTING CHATTER UNDER LOAD GO-
 ING UP HILLS
 PERFORM EEC TEST CK FOR CODES HAS NO ACTIVE CODES STORED
 ROAD TEST VEHICLE UNABLE TO VERIFY CONCERN

JOB# 2 TOTALS-----

JOB# 2 JOURNAL PREFIX FTCS JOB# 2 TOTAL 0.00

TOTALS-----

*****	TOTAL LABOR....	0.00
*	TOTAL PARTS....	0.00
* [] CASH [] CHECK CK NO. []	TOTAL SUBLET...	0.00
*	TOTAL G.O.G....	0.00
* [] VISA [] MASTERCARD	TOTAL MISC CHG.	0.00
*	TOTAL MISC DISC	0.00
* [] AMEX [] CHARGE	TOTAL TAX.....	0.00
*****	TOTAL INVOICE \$	0.00

THANK YOU FOR YOUR BUSINESS!!

PLEASE PRINT NAME

CUSTOMER SIGNATURE

The Reynolds and Reynolds Company EPRALZRNVE CC217187 0 (04/09)



MEADOWLAND FORD TRUCK SALES INC.

330 County Avenue
Secaucus, New Jersey 07096

SALES: (201) 617-0700 FAX: (201) 617-9843
 Mon. thru Fri. 8 to 6; Sat. 9 to 1
 SERVICE: (201) 617-5577
 Mon thru Fri. 7:30 - 7:00 Sat. 8:00 - 3:00
 PARTS: (201) 617-5200 FAX: (201) 617-9793
 Mon. thru Fri. 7:30 - 7:00 Sat. 8:00 - 12:00

Called

CELL: [REDACTED]

CUSTOMER NO. 28025	ADVISOR MICHAEL COAKLEY	TAG NO. 2552	INVOICE DATE 08/10/10	INVOICE NO. FTCS196116
[REDACTED]	LABOR RATE 108.00	LICENSE NO.	MILEAGE 35,289	COLOR OXFORD WHIT
BAYONNE, NJ	YEAR / MAKE / MODEL 08/FORD TRUCK/F350/TRK CREW CAB SRW		DELIVERY DATE 07/02/09	STOCK NO. 1293
	VEHICLE I.D. NO. 1 F T W W 3 1 R 2 8 E		SELLING DEALER NO.	DELIVERY MILES 39
	F.T.E. NO.	P.O.	R.O. DATE 08/03/10	PRODUCTION DATE
RESIDENCE PHONE	BUSINESS PHONE	COMMENTS		

MO: 35291

JOB# 1 CHARGES-----

LABOR-----
 J# 1 10FTZ06 CHECK ENGINE LIGHT HOURS: TECH(S): 9945 WARRANTY
 CUSTOMER STATES CHECK ENGINE LIGHT ON
 PERFORM ENGINE DIAG REPROGRAM CONTROL MODULES ROAD TEST PIN
 POINT TEST FOUND EGT SENOSR OUT OF SPEC REPLACE SENSOR
 CLEAR SYSTEM RETEST ROAD TEST TRUCK

JOB# 1 TOTALS-----
 JOB# 1 JOURNAL PREFIX FTCS JOB# 1 TOTAL 0.00

JOB# 2 CHARGES-----

LABOR-----
 J# 2 45FTZ STEERING/SUSPENSION HOURS: TECH(S): 9945 INTERNAL
 CUST STATES CK STEERING AND SUSPENSION VEHICLE PULLS TO LEFT
 INSTALL CAMBER BUSHING RESET CAMBER, CASTER, TOE ROAD TEST
 TRUCK OK.

PARTS-----QTY---FP-NUMBER-----DESCRIPTION-----UNIT PRICE-----INTERNAL
 2 5C3Z-3B440-EEE ADJUSTER 2 120684 TOTAL - PARTS 0.00

JOB# 2 TOTALS-----
 JOB# 2 JOURNAL PREFIX FTCS JOB# 2 TOTAL 0.00

JOB# 3 CHARGES-----

LABOR-----
 J# 3 60FTZ08 CONSOLE HOURS: TECH(S): 9945 0.00
 CUST STTAAES ARM REST MAKING CLICKING NOISE WHILE DRIVING
 UNABLE TO VERFIY CONCERN

JOB# 3 TOTALS-----
 JOB# 3 JOURNAL PREFIX FTCS JOB# 3 TOTAL 0.00

JOB# 4 CHARGES-----

LABOR-----
 J# 4 05FTZ19 TIRE ROTATION HOURS: TECH(S): 9945 0.00
 CUSTOMER REQUESTS TIRE ROTATION
 CUSTOMER REQUESTS TIRE ROTATION
 PERFORMED TIRE ROTATION

JOB# 4 TOTALS-----
 JOB# 4 JOURNAL PREFIX FTCS JOB# 4 TOTAL 0.00

JOB# 5 CHARGES-----

LABOR-----
 J# 5 20FTZ02 COOLING SYSTEM HOURS: TECH(S): 9945 WARRANTY
 CUST STATES CK FAN SHROULD CRACKING
 CK SHROUD FOUND CRACKING REPLACE SHROUD

The Reynolds and Reynolds Company EPALZRRNVE C2317187 Q (04/99)



MEADOWLAND FORD TRUCK SALES INC.

330 County Avenue
Secaucus, New Jersey 07096

SALES: (201) 617-0700 FAX: (201) 617-9843
 Mon. thru Fri. 8 to 6; Sat. 9 to 1
 SERVICE: (201) 617-5577
 Mon thru Fri. 7:30 - 7:00 Sat. 8:00 - 3:00
 PARTS: (201) 617-5200 FAX: (201) 617-9793
 Mon. thru Fri. 7:30 - 7:00 Sat. 8:00 - 12:00

Called

CUSTOMER NO 28025	ADVISOR MICHAEL COAKLEY	2552	TAG NO.	INVOICE DATE 07/09/09	CELL FTCS192577
	LABOR RATE 108.00	LICENSE NO.	MILEAGE 370	COLOR OXFORD WHIT	STOCK NO. 1293
BAYONNE, NJ	YEAR / MAKE / MODEL 08 / FORD TRUCK / F350 / TRK CREW CAB SRW			DELIVERY DATE 07/02/09	DELIVERY MILES 39
	VEHICLE I.D. NO. 1 F T W W 3 1 R 2 8 E			SELLING DEALER NO.	PRODUCTION DATE
	F.T.E. NO.	P.O. NO.		R.O. DATE 07/06/09	
COMMENTS					MO: 375

JOB# 1 CHARGES-----

LABOR-----
 # 1 515710 POWER WINDOWS HOURS TECH(S) 20457 WARRANTY

CUST STATES DRIVER REAR DOOR WINDOW INOP
 VERFIY CONCERN REMOVE DOOR PANEL CK MOTOR FOUND INOP REPLACE
 MOTOR REGULATOR ASSEMBLE REINSTALL PANEL RECHECK OK.

PARTS-----	QTY-----	FP-NUMBER-----	DESCRIPTION-----	UNIT PRICE-----	WARRANTY
	1	8C3Z-2627001-B	REGULATO 1 375282		
				TOTAL - PARTS	0.00

JOB# 1 TOTALS-----

JOB# 1 JOURNAL PREFIX FTCS JOB# 1 TOTAL 0.00

JOB# 2 CHARGES-----

LABOR-----
 # 2 451703 SUSPENSION CONCERN HOURS TECH(S) 20069 WARRANTY

Added Operation (MIKEC @ 07/08/2009 12:11)
 CUST STATES CK FT SUSPENSION PULLS TO THE LEFT
 ROAD TEST VECHILE INSPECT FT SUSPENSION OK ROTATE FT TIRES
 LEFT TO RIGHT REROAD TEST OK.

JOB# 2 TOTALS-----

JOB# 2 JOURNAL PREFIX FTCS JOB# 2 TOTAL 0.00

TOTALS-----

*****		TOTAL LABOR....	0.00
* [] CASH [] CHECK CK NO. [] *		TOTAL PARTS....	0.00
* [] VISA [] MASTERCARD *		TOTAL SUBLET...	0.00
* [] AMEX [] CHARGE *		TOTAL G.O.G....	0.00
*****		TOTAL MISC CHG.	0.00
		TOTAL MISC DISC	0.00
		TOTAL TAX.....	0.00
		TOTAL INVOICE \$	0.00

THANK YOU FOR YOUR BUSINESS!!

PLEASE PRINT NAME

CUSTOMER SIGNATURE

HEAGEN, PAGANO & SEEMS, P.A.
325 W. WATER STREET
TOMS RIVER, N.J. 08754
(732) 286-9800
Attorneys for Plaintiff

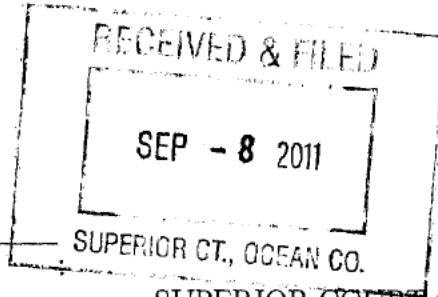

[REDACTED]

vs. **Plaintiff**

FORD MOTOR COMPANY,
MEADOWLAND FORD TRUCK SALES, INC.,
DOWNS FORD, and ABC CORP (1-10)
(said names being fictitious),

Defendants

SUPERIOR COURT
NEW JERSEY

LAW DIVISION
OCEAN COUNTY

DOCKET NO. [REDACTED]

CIVIL ACTION

COMPLAINT

Plaintiff, [REDACTED] whose primary residence is at [REDACTED], Bayonne, New Jersey, by way of Complaint against the Defendants says:

FACTS COMMON TO ALL COUNTS

1. Defendant Ford Motor Company is a company that manufactures automobiles and has a business address at One American Road, Dearborn, Michigan 48126.
2. Defendant Meadowland Ford Truck Sales, Inc. is a company that sells and repairs Ford motor vehicles and has a business address at 330 County Avenue, Seacaucus, New Jersey 07096.
3. Defendant Downs Ford is a company that sells and repairs Ford motor vehicles and has a business address at 360 Route 37 East, Toms River, New Jersey 08753.
4. On July 2, 2009, Plaintiff purchased from Defendant Meadowland Ford Truck Sales, Inc. a 2008 Ford F350 4x4 Crew Cab Truck, vehicle identification number

1FTWW31R28E [REDACTED]. The purchase price was \$43,300.00

5. The aforementioned truck was manufactured by Defendant, Ford Motor Company.

6. On July 6, 2009, Plaintiff returned the truck to Meadowland Ford with complaints that the suspension pulled to the left. The vehicle was allegedly repaired and returned on July 9, 2009.

7. On September 14, 2009, Plaintiff returned the truck to Meadowland Ford with complaints that the wheel pulls to the left. The vehicle was allegedly repaired and returned on September 15, 2009.

8. On June 7, 2010, Plaintiff returned the truck to Meadowland Ford with complaints that the front end wanders when driving. The vehicle was allegedly repaired and returned on June 10, 2010.

9. On June 21, 2010, Plaintiff returned the truck to Meadowland Ford with complaints that the front end of the vehicle goes all over the place. The vehicle was allegedly repaired and returned on June 23, 2010.

10. On August 3, 2010, Plaintiff returned the vehicle to Meadowland Ford with complaints that the vehicle pulls to the left. The vehicle was allegedly repaired and returned on August 10, 2010.

11. On May 6, 2011, Plaintiff returned the vehicle to Downs Ford with complaints that the wheels locked up. The vehicle was allegedly repaired and returned on May 9, 2010.

12. On December 21, 2010 Plaintiff returned the vehicle to Downs Ford with complaints that the engine shut down and cranks to start. The vehicle was allegedly

repaired and returned on January 13, 2011.

13. On May 6, 2011, Plaintiff returned the vehicle to Downs Ford with complaints that the wheels locked up. The vehicle was allegedly repaired and returned on May 9, 2011.

14. On May 26, 2011, Plaintiff returned the vehicle to Downs Ford with complaints about the tires. The vehicle was allegedly repaired and returned on June 14, 2011.

15. On June 15, 2011, Plaintiff returned the vehicle to Downs Ford with complaints that the front wheel was pulling right and smoking. The vehicle was allegedly repaired and returned on June 16, 2011.

16. On June 21, 2011, Plaintiff returned the vehicle to Meadowland Ford with complaints about the lower coolant tube leaking. The vehicle was allegedly repaired and returned on June 21, 2011.

17. On June 29, 2011, Plaintiff returned the vehicle to Downs Ford with complaints that there may be a coolant leak. The vehicle was allegedly repaired and returned on June 29, 2011.

18. On July 18, 2011, Plaintiff returned the vehicle to Downs Ford with complaints that there is excessive play in the steering and no power. The vehicle was allegedly repaired and returned on August 5, 2011.

FIRST COUNT

1. Plaintiff repeats and realleges the facts set forth hereinabove as more fully set forth herein.
2. Defendant, Ford Motor Company, be releasing the subject vehicle to Meadowland

Ford Truck Sales, Inc. for retail sale, impliedly warranted the truck was fit for the purpose for which it was designed, and that it was safe and suitable to be used on the roadway.

3. In reliance on Defendant's skill and judgment and the implied warranties of fitness for that purpose, Plaintiff purchased the subject vehicle.
4. As a direct and proximate result of the actions or inactions noted hereinabove, Defendant has breached its implied warranty of fitness and Plaintiff has been damaged.

WHEREFORE, Plaintiff demands judgment against Defendant awarding to Plaintiff damages, counsel fees, interest, costs of suit, and such other relief as the Court deems just and equitable.

SECOND COUNT

1. Plaintiff repeats and realleges the Paragraphs of the First Count as if same were set forth at length herein.
2. Defendant, Ford Motor Company impliedly warranted that the subject vehicle was of merchantable quality, fit, safe and in proper condition for the ordinary use for which trucks are designed and used.
3. In reliance on this implied warranty of merchantability by the Defendant, Plaintiff purchased the truck.
4. As a direct and proximate result of the actions or inactions noted hereinabove, Defendant has breached its implied warranty of merchantability and Plaintiff has been damaged.

WHEREFORE, Plaintiff demands judgment against Defendant awarding to

Plaintiff damages, counsel fees, interest, costs of suit, and such other relief as the Court deems just and equitable.

THIRD COUNT

1. Plaintiff repeats and realleges each and every allegation of the previous Counts as if same were set forth at length herein.
2. Prior to the purchase of the truck by Plaintiff, Defendant Ford Motor Company induced purchases of the truck by expressly warranting to Plaintiff by advertisements directed to the attention of the public and particularly to ultimate consumers, that the consumers, including the Plaintiff, could safely use the truck and that such use would require no attention or special precautions.
3. Defendant expressly warranted in its advertising that the truck was safe and fit.
4. As a direct and proximate result of the actions or inactions noted hereinabove, Defendant has breached its express warranty in advertising and Plaintiff has been damaged.

WHEREFORE, Plaintiff demands judgment against Defendant awarding to Plaintiff damages, counsel fees, interest, costs of suit, and such other relief as the Court deems just and equitable.

FOURTH COUNT

1. Plaintiff repeats and realleges each and every allegation of the previous Counts as if same were set forth at length herein.
2. At such date as hereinabove alleged, Defendants, and each and all of them knew that such product would be used, and in fact was used, in a manner intended by the Defendants.

3. Said Defendants knew that a dangerous condition existed when the truck left control of the Defendants.
4. As a direct and proximate result of the actions or inactions noted hereinabove, Defendant has been damaged.

WHEREFORE, Plaintiff demands judgment against Defendant awarding to Plaintiff damages, counsel fees, interest, costs of suit, and such other relief as the Court deems just and equitable.

FIFTH COUNT

1. Plaintiff repeats and realleges each and every allegation of the previous Counts as if same were set forth at length herein.
2. Prior to the purchase of the truck by Plaintiff, Defendant Ford Motor Company induced purchases of the truck by expressly warranting to Plaintiff by advertisements directed to the attention of the public and particularly to ultimate consumers, that the consumers, including the Plaintiff, could safely use the truck and that such use would require no attention or special precautions.
3. Defendant expressly warranted in its advertising that the truck was safe and fit.
4. As a direct and proximate result of the actions or inactions noted hereinabove, Defendant has breached its express warranty in advertising and Plaintiff has been damaged.

WHEREFORE, Plaintiff demands judgment against Defendant awarding to Plaintiff damages, counsel fees, interest, costs of suit, and such other relief as the Court deems just and equitable.

SIXTH COUNT

1. Plaintiff repeats and realleges each and every allegation of the previous Counts as if same were set forth at length herein.
2. On or about such date as hereinabove alleged, Defendants did implicitly and expressly warrant that the truck would be merchantable and would serve the purpose intended.
3. As a direct and proximate result of the actions or inactions noted hereinabove, Defendant has breached its warranty and Plaintiff has been damaged.

WHEREFORE, Plaintiff demands judgment against Defendant awarding to Plaintiff damages, counsel fees, interest, costs of suit, and such other relief as the Court deems just and equitable.

SEVENTH COUNT

1. Plaintiff repeats and realleges each and every allegation of the previous Counts as if same were set forth at length herein.
2. At all times mentioned, Defendant, Ford Motor Company sold its manufactured goods in the State of New Jersey.
3. Plaintiff is a member of the general public residing in the State of New Jersey.
4. Defendant, through its officers, agents, servants, representatives, or employees, negligently and recklessly misrepresented the fitness, quality and character of the subject vehicle.
5. These misrepresentations were made and the Defendant knew or should have known that the misrepresentations were not true.
6. But for the falsity of the representations made, Plaintiff would not have

purchased the subject vehicle.

7. As a direct and proximate result of the actions or inactions noted hereinabove, Defendant has negligently misrepresented facts and Plaintiff has been damaged.

WHEREFORE, Plaintiff demands judgment against Defendant awarding to Plaintiff damages, counsel fees, interest, costs of suit, and such other relief as the Court deems just and equitable.

EIGHTH COUNT

1. Plaintiff repeats and realleges each and every allegation of the previous Counts as if same were set forth at length herein.

2. At all times mentioned, Defendants, Meadowland Ford Truck Sales, inc. and Downs Ford performed repair work on the subject vehicle.

3. Said Defendants negligently and carelessly installed, repaired, manufactured, assembled, and inspected various motor vehicle parts.

4. As a direct and proximate result of the actions or inactions noted hereinabove, Defendant has negligently misrepresented facts and Plaintiff has been damaged.

WHEREFORE, Plaintiff demands judgment against Defendant awarding to Plaintiff damages, counsel fees, interest, costs of suit, and such other relief as the Court deems just and equitable.

NINTH COUNT

1. Plaintiff repeats and realleges each and every allegation of the previous Counts as if same were set forth at length herein.

2. At all times mentioned, Defendant, Ford Motor Company negligently manufactured the subject vehicle and thereafter permitted same to be sold to Plaintiff.

3. As a direct and proximate result of the actions or inactions noted hereinabove, Defendant has violated N.J.S.A. 56:12-19 to 56:12-49 "New Jersey Lemon Law." and Plaintiff has been damaged.

WHEREFORE, Plaintiff demands judgment against Defendant awarding to Plaintiff that Defendant take return of the subject vehicle, refund to Plaintiff his purchase fees, and damages, counsel fees, interest, costs of suit, and such other relief as the Court deems just and equitable.

DESIGNATION OF TRIAL COUNSEL

Pursuant to R. 4:25-4, ANTHONY M. PAGANO, is hereby designated as trial counsel for the within matter.

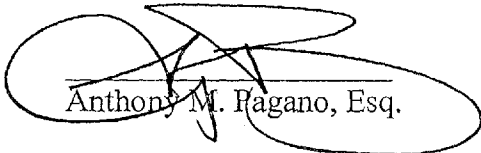

Anthony M. Pagano, Esq.

DATED: August 22, 2011

CERTIFICATION

The matter in controversy involved in this action is not the subject of any other action pending in any other Court, nor of any pending arbitration proceeding and no other action or arbitration proceeding is contemplated by my client. No parties other than those named herein should be joined in this action.

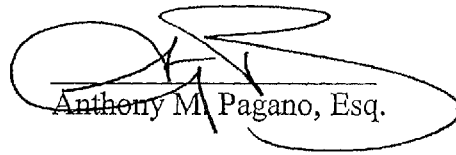
I certify that the foregoing is true to the best of my knowledge, information, and belief.

Anthony M. Pagano, Esq.

DATED: August 22, 2011

Server: **AWS Prod**
 Claims loaded through: **01-DEC-2011**

STANDARD CLAIMS LIST

AWS Online Report

Run Date: 02-DEC-11

Note: All Costs are in US Dollars Server Name: AWS Prod Claims loaded through

VIN	AWS VL	WERS VL	MKT DER	BODY CAB	VER SERIES	DRIVE TYPE	PLANT CD	TRANS CD	ENG COD	PROD DATE	WARR DATE	SELLING DEALER	SELL CNT	TIS	WCC	PREF	BASE	SUFF	VRT NA	VRT ROW	VFG	CCC	CD
1FTWW31R28E [REDACTED]		T/F7	F	T/BC	T/CD	T/E	A1	T/BE	T/QL	02-APR-2008	02-JUL-2009	113955	USA	0	1F01	*	8009	*	F04	S11	V45	L87	53
AWS Claim Key:	<u>1362586</u>	Doc #: 18941201	Trx Code:	2	Labor Hrs: .3	Labor Cost: 33.23	Material Cost: 4.19	Total Cost: 37.42															
Dir Cd-Sub Cd:	03714-*	Name: MEADOWLAND FORD TRUCK SALES, INC.	Ph: 201-6170700	St: NJ	Ctry Cd: USA	Reg Cd: NA	Repr Date: 12-AUG-2008	DIST(Mile): 7															
Cust Comments:	RECALL 08T01																						
Tech Comments:	INSTALL VENTURI TEE PER 08T01																						
1FTWW31R28E [REDACTED]		T/F7	F	T/BC	T/CD	T/E	A1	T/BE	T/QL	02-APR-2008	02-JUL-2009	113955	USA	0	2G01	*	*	*	F09	SXX	V00	*	*
AWS Claim Key:	<u>2663000</u>	Doc #: 19109901	Trx Code:	08B07	Labor Hrs: .5	Labor Cost: 55.39	Material Cost: 0	Total Cost: 55.39															
Dir Cd-Sub Cd:	03714-*	Name: MEADOWLAND FORD TRUCK SALES, INC.	Ph: 201-6170700	St: NJ	Ctry Cd: USA	Reg Cd: NA	Repr Date: 29-JAN-2009	DIST(Mile): 51															
Cust Comments:	RECALL 08B07																						
Tech Comments:	REPROGRAM PCM AND IC																						
1FTWW31R28E [REDACTED]		T/F7	F	T/BC	T/CD	T/E	A1	T/BE	T/QL	02-APR-2008	02-JUL-2009	113955	USA	1	5K01	*	1015	*	F05	S10	V89	H25	42
AWS Claim Key:	<u>3905800</u>	Doc #: 19257702	Trx Code:	2	Labor Hrs: .8	Labor Cost: 89.06	Material Cost: 0	Total Cost: 89.06															
Dir Cd-Sub Cd:	03714-*	Name: MEADOWLAND FORD TRUCK SALES, INC.	Ph: 201-6170700	St: NJ	Ctry Cd: USA	Reg Cd: NA	Repr Date: 06-JUL-2009	DIST(Mile): 370															
Cust Comments:	CUST STATES CK FT SUSPENSION PULLS TO THE LEFT																						
Tech Comments:	TEST DRIVE, PULLS TO LEFT. CK FRONT END. TIGHT & OK. SWAP LEFT & RT FRONT WHEELS. RETEST DRIVE OK MT1007RT DIAG AND ROTATE FRONT TIRES																						
1FTWW31R28E [REDACTED]		T/F7	F	T/BC	T/CD	T/E	A1	T/BE	T/QL	02-APR-2008	02-JUL-2009	113955	USA	1	7N02	8C3Z	2627001	B	F08	S06	V09	G07	42
AWS Claim Key:	<u>3905801</u>	Doc #: 19257701	Trx Code:	2	Labor Hrs: .6	Labor Cost: 66.79	Material Cost: 67.86	Total Cost: 134.65															

Dlr Cd-Sub Cd: 03714-* **Name:** MEADOWLAND FORD TRUCK SALES, INC. **Ph:** 201-6170700 **St:** NJ **Ctry Cd:** USA **Reg Cd:** NA **Repr Date:**06-JUL-2009 **DIST(Mile):**370
Cust Comments: CUST STATES DRIVER REAR DOOR WINDOW INOP
Tech Comments: CK & VERIFY CK ALL FUSES OK. CK FOR POWER & GROUND TO WINDOW MOTOR GOOD. R+I DOOR PANEL. FOUND MOTOR INOP. REPL MOTOR & REGULATOR ASY. CK OK

1FTWW31R28E [REDACTED] T/F7 F T/BC T/CD T/E A1 T/BE T/QL 02-APR-2008 02-JUL-2009 113955 USA 3 5G05 * FRONT * F05 S10 V89 H25 W6
AWS Claim Key: 4533138 **Doc #:** 19312201 **Trx Code:** 2 **Labor Hrs:** 1.8 **Labor Cost:** 200.38 **Material Cost:** 0 **Total Cost:** 200.38
Dlr Cd-Sub Cd: 03714-* **Name:** MEADOWLAND FORD TRUCK SALES, INC. **Ph:** 201-6170700 **St:** NJ **Ctry Cd:** USA **Reg Cd:** NA **Repr Date:**14-SEP-2009 **DIST(Mile):**7774
Cust Comments: CUST STATES AT HIGHWAY SPEED LET GO OF WHEEL PULLS TO LEFT
Tech Comments: ROAD TEST, VERIFY CONCERN. PUT ON ALIGNMENT MACHINE. SET CASTER,CAMBER, AND TOE IN.

1FTWW31R28E [REDACTED] T/F7 F T/BC T/CD T/E A1 T/BE T/QL 02-APR-2008 02-JUL-2009 113955 USA 3 2H01 * 6N639 * F04 S11 V44 L65 D8
AWS Claim Key: 4561468 **Doc #:** 19312204 **Trx Code:** 2 **Labor Hrs:** 6.9 **Labor Cost:** 768.11 **Material Cost:** 33.66 **Total Cost:** 801.77
Dlr Cd-Sub Cd: 03714-* **Name:** MEADOWLAND FORD TRUCK SALES, INC. **Ph:** 201-6170700 **St:** NJ **Ctry Cd:** USA **Reg Cd:** NA **Repr Date:**14-SEP-2009 **DIST(Mile):**7774
Cust Comments: CUST STATES ENGINE HAS OIL LEAK
Tech Comments: FOOOUND OIL LEAK. COMING FROM THE TOP OF THE ENGINE. ADDED OIL AND LEAK DYE. FOUND GASKET LEKAING UNDER TURBO PEDESTRAL. R& I TURBO. REPL GASKET. RECHECK OK. STEAM CLEAN ENGINE MT6N639 RIME TO R&I TURBO AND REPL GASKET UNDER PEDESTAL. MT6N639AXR STEAM CLEAN

1FTWW31R28E [REDACTED] T/F7 F T/BC T/CD T/E A1 T/BE T/QL 02-APR-2008 02-JUL-2009 113955 USA 3 1G03 AC3Z 8620 A F04 S11 V44 E19 42
AWS Claim Key: 4525750 **Doc #:** 19312205 **Trx Code:** 2 **Labor Hrs:** 1.6 **Labor Cost:** 178.11 **Material Cost:** 26.65 **Total Cost:** 204.76
Dlr Cd-Sub Cd: 03714-* **Name:** MEADOWLAND FORD TRUCK SALES, INC. **Ph:** 201-6170700 **St:** NJ **Ctry Cd:** USA **Reg Cd:** NA **Repr Date:**14-SEP-2009 **DIST(Mile):**7774
Cust Comments: CUST STATES CK FOR SQUESLING NOISE ON START UP
Tech Comments: CK FOR NOISE WHE NCOLD. FOUND BELT MAKING NOISE. CK OASIS TSB 09 09 08 REPLE BELT. RECHECK NEXT DAY OK

1FTWW31R28E [REDACTED] T/F7 F T/BC T/CD T/E A1 T/BE T/QL 02-APR-2008 02-JUL-2009 113955 USA 12 6E01 8C3Z 2560136 AC F07 S08 V03 S03 24
AWS Claim Key: 6022465 **Doc #:** 19561104 **Trx Code:** E84 **Labor Hrs:** .7 **Labor Cost:** 80.11 **Material Cost:** 368.33 **Total Cost:** 448.44
Dlr Cd-Sub Cd: 03714-* **Name:** MEADOWLAND FORD TRUCK SALES, INC. **Ph:** 201-6170700 **St:** NJ **Ctry Cd:** USA **Reg Cd:** NA **Repr Date:**07-JUN-2010 **DIST(Mile):**33511
Cust Comments: CUST STATES CENTER ARMREST CLICKS AND FEELS LOOSE
Tech Comments: CK CENTER ARMREST LOOSE AND PLASTIC. REPL CENTER CONSOLE ARM REST

1FTWW31R28E [REDACTED] T/F7 F T/BC T/CD T/E A1 T/BE T/QL 02-APR-2008 02-JUL-2009 113955 USA 12 6E10 8C3Z 2562187 AB F07 S08 V03 S03 34
AWS Claim Key: 6022464 **Doc #:** 19561105 **Trx Code:** E84 **Labor Hrs:** .3 **Labor Cost:** 34.33 **Material Cost:** 65.22 **Total Cost:** 99.55

Dir Cd-Sub Cd: 03714-* **Name:** MEADOWLAND FORD TRUCK SALES, INC. **Ph:** 201-6170700 **St:** NJ **Ctry Cd:** USA **Reg Cd:** NA **Repr Date:**07-JUN-2010 **DIST(Mile):**33511
Cust Comments: CUST STATES LS SEAT TRIM PANEL COMING OFF
Tech Comments: FOUND TRIM PANEL ON LEFT FRONT SEAT DISTORTED. REPL LEFT FRT SEAT TRIM PANEL

IFTWW31R28E [REDACTED] T/F7 F T/BC T/CD T/E A1 T/BE T/QL 02-APR-2008 02-JUL-2009 113955 USA 12 5001 8C3Z 3504 CRM F02 S10 V87 L68 D8
AWS Claim Key: 6029558 **Doc #:** 19561101 **Trx Code:** E84 **Labor Hrs:** 2.2 **Labor Cost:** 251.77 **Material Cost:** 440.22 **Total Cost:** 691.99
Dir Cd-Sub Cd: 03714-* **Name:** MEADOWLAND FORD TRUCK SALES, INC. **Ph:** 201-6170700 **St:** NJ **Ctry Cd:** USA **Reg Cd:** NA **Repr Date:**07-JUN-2010 **DIST(Mile):**33511
Cust Comments: CUSTOMER STATES POWER STEERING FLUID LEAKING OR TRANS FLUID LEAKING NEAR PS PUMP
Tech Comments: DISCONNECT R&L FRT SPINDLES FROM STEERING GEAR. MOVE FRONT END COMPONENTS INDIVIDUALLY FROM STEERING GEAR. FOUND STEERING GEAR BINDING WHEN TURNING & LEAKING AND STEERING DAMPER LEAK

IFTWW31R28E [REDACTED] T/F7 F T/BC T/CD T/E A1 T/BE T/QL 02-APR-2008 02-JUL-2009 113955 USA 14 1F05 7C3Z 8146 F F04 S11 V44 D50 01
AWS Claim Key: 6369061 **Doc #:** 19611605 **Trx Code:** E84 **Labor Hrs:** 1.5 **Labor Cost:** 171.66 **Material Cost:** 133.89 **Total Cost:** 305.55
Dir Cd-Sub Cd: 03714-* **Name:** MEADOWLAND FORD TRUCK SALES, INC. **Ph:** 201-6170700 **St:** NJ **Ctry Cd:** USA **Reg Cd:** NA **Repr Date:**03-AUG-2010 **DIST(Mile):**35289
Cust Comments: CUST STATES CK FAN SHROULD CRACKING
Tech Comments: CK FAN SHROUD FOUND CRACKED. REPL SHROUD OK

IFTWW31R28E [REDACTED] T/F7 F T/BC T/CD T/E A1 T/BE T/QL 02-APR-2008 02-JUL-2009 113955 USA 14 2G02 8C3Z 12B591 D F04 S11 V29 E29 42
AWS Claim Key: 6369062 **Doc #:** 19611601 **Trx Code:** S07 **Labor Hrs:** 1.4 **Labor Cost:** 160.21 **Material Cost:** 69.46 **Total Cost:** 229.67
Dir Cd-Sub Cd: 03714-* **Name:** MEADOWLAND FORD TRUCK SALES, INC. **Ph:** 201-6170700 **St:** NJ **Ctry Cd:** USA **Reg Cd:** NA **Repr Date:**03-AUG-2010 **DIST(Mile):**35289
Cust Comments: CUSTOMER STATES CHECK ENGINE LIGHT ON
Tech Comments: CK ENGINE LIGHT IS ON. DIAG ALONG WITH PERFORMANCE SHEET REPROGRAM CONTROL MODULES PER TSB 09 19 10. CLEAR CODES. ROAD TEST CK ENGINE LIGHT CAME ON. RETEST P242C EGT13 SENSOR MALFUNCTION. MT091910 TIME TO RECALIBRATE MODULES PER TSB

IFTWW31R28E [REDACTED] T/F7 F T/BC T/CD T/E A1 T/BE T/QL 02-APR-2008 02-JUL-2009 113955 USA 15 6E01 8C3Z 2560136 AC F07 S08 V71 B95 33
AWS Claim Key: 6587987 **Doc #:** 19639002 **Trx Code:** SPW **Labor Hrs:** .8 **Labor Cost:** 91.55 **Material Cost:** 368.33 **Total Cost:** 459.88
Dir Cd-Sub Cd: 03714-* **Name:** MEADOWLAND FORD TRUCK SALES, INC. **Ph:** 201-6170700 **St:** NJ **Ctry Cd:** USA **Reg Cd:** NA **Repr Date:**08-SEP-2010 **DIST(Mile):**41105
Cust Comments: CUST STATES CENTER ARMREST LOOSE
Tech Comments: CK CENTER ARMREST. FOUND LOOSE. CK MOUNTING BRACKETS LOOSE INSIDE ARMREST ASY. REPL ARMREST. SPW RO195611 060710 33511 MILES

IFTWW31R28E [REDACTED] T/F7 F T/BC T/CD T/E A1 T/BE T/QL 02-APR-2008 02-JUL-2009 113955 USA 18 2E03 * 9A543 * F04 S11 V52 D02 42
AWS Claim Key: 7123832 **Doc #:** 06255351 **Trx Code:** E72 **Labor Hrs:** 39.1 **Labor Cost:** 3785.68 **Material Cost:** 5902.8 **Total Cost:** 9688.48

Dir Cd-Sub Cd: 20681-* **Name:** DOWNS FORD, INC. **Ph:** 732-3492240 **St:** NJ **Ctry Cd:** USA **Reg Cd:** NA **Repr Date:**21-DEC-2010 **DIST(Mile):**52709

Cust Comments: TOWED TO SHOP C S ENGINE DIDNT SOUND RIGHT, SHUT DOWN, NOW CRANKS NO START MTIME FOR CAGE NUT ACCESS,COMP TESTS,CLEANING OF FUEL SYSTEM NO PUBLISHED TIMES BY FORD

Tech Comments: CHECKED OUT & TESTED, FOUND METAL PERTICLES IN SECONDARY FUEL FILTER. CODES FOR LOW FUEL PRESSURE, HI PRESSURE FUEL PUMP COMING APART, DISSASSEMBLED & REPLACED HI PRESSURE FUEL PUMP, ALL 8 FUEL INJECTORS, HI PRESSURE FUEL RAILS, REPLACED LOW PRESSURE PUMP, FLUSHED HI & LOW PRESSURE FUEL LINES & TANK, REPL. FUEL FILTERS & CLEANED HOUSING, REPL. FUEL REGULATOR PRESSURE SENSOR, RE ASSEMBLED. ADDE

1FTWW31R28 [REDACTED] T/F7 F T/BC T/CD T/E A1 T/BE T/QL 02-APR-2008 02-JUL-2009 113955 USA 22 5K06 * * * F09 SXX V00 * *

AWS Claim Key: 7505971 **Doc #:** 06855852 **Trx Code:** 11B24 **Labor Hrs:** 0 **Labor Cost:** 0 **Material Cost:** 0 **Total Cost:** 0

Dir Cd-Sub Cd: 20681-* **Name:** DOWNS FORD, INC. **Ph:** 732-3492240 **St:** NJ **Ctry Cd:** USA **Reg Cd:** NA **Repr Date:**05-APR-2011 **DIST(Mile):**58313

Cust Comments: 11B24 CONTINENTAL TIRE INSPECTION

Tech Comments: 11B24 CHECKED AS PER RECALL TIRES OK

1FTWW31R28 [REDACTED] T/F7 F T/BC T/CD T/E A1 T/BE T/QL 02-APR-2008 02-JUL-2009 113955 USA 22 5B03 5C3Z 3254 AA F04 S11 V51 L88 D8

AWS Claim Key: 7528632 **Doc #:** 06855853 **Trx Code:** E95 **Labor Hrs:** 2.7 **Labor Cost:** 261.41 **Material Cost:** 91.3 **Total Cost:** 352.71

Dir Cd-Sub Cd: 20681-* **Name:** DOWNS FORD, INC. **Ph:** 732-3492240 **St:** NJ **Ctry Cd:** USA **Reg Cd:** NA **Repr Date:**05-APR-2011 **DIST(Mile):**58313

Cust Comments: C S DUST SEAL RIGHT FRONT AXLE LOOSE

Tech Comments: CK FOUND DUST SEAL OUT OF PLACE. R&R RGT AXLE SHAFT, MTIME NO PUB TIME REPL DUST AND HUB AND VAC SEALS, REASSEM CK OPERATION OK

1FTWW31R28 [REDACTED] T/F7 F T/BC T/CD T/E A1 T/BE T/QL 02-APR-2008 02-JUL-2009 113955 USA 22 * * * * F09 SXX V00 * *

AWS Claim Key: 7505970 **Doc #:** 06855851 **Trx Code:** 11B23 **Labor Hrs:** .5 **Labor Cost:** 48.41 **Material Cost:** 0 **Total Cost:** 48.41

Dir Cd-Sub Cd: 20681-* **Name:** DOWNS FORD, INC. **Ph:** 732-3492240 **St:** NJ **Ctry Cd:** USA **Reg Cd:** NA **Repr Date:**05-APR-2011 **DIST(Mile):**58313

Cust Comments: 11B23 POWERTRAIN CONTROL MODULE RECALIBRATION RECALL

Tech Comments: 11B23 RE PROGRAMMED AS PER RECALL

1FTWW31R28 [REDACTED] T/F7 F T/BC T/CD T/E A1 T/BE T/QL 02-APR-2008 02-JUL-2009 113955 USA 22 5G03 BC3Z 3050 B F05 S10 V89 H26 42

AWS Claim Key: 7528633 **Doc #:** 06855854 **Trx Code:** 0968D **Labor Hrs:** 3.5 **Labor Cost:** 338.87 **Material Cost:** 248.84 **Total Cost:** 587.71

Dir Cd-Sub Cd: 20681-* **Name:** DOWNS FORD, INC. **Ph:** 732-3492240 **St:** NJ **Ctry Cd:** USA **Reg Cd:** NA **Repr Date:**05-APR-2011 **DIST(Mile):**58313

Cust Comments: C S VEHICLE PULLS TO THE LEFT

Tech Comments: LFT UPPER& LWER BALL JOINTS LOOSEBALL JOINT REPLACE

1FTWW31R28 [REDACTED] T/F7 F T/BC T/CD T/E A1 T/BE T/QL 02-APR-2009 02-JUL-2009 113955 USA 22 1G04 7C3Z 8678 B F05 S11 V49 N11 42

2008
AWS Claim Key: 7505972 **Doc #:** 06855855 **Trx Code:** E72 **Labor Hrs:** 1.7 **Labor Cost:** 164.59 **Material Cost:** 84.55 **Total Cost:** 249.14
Dir Cd-Sub Cd: 20681-* **Name:** DOWNS FORD, INC. **Ph:** 732-3492240 **St:** NJ **Ctry Cd:** USA **Reg Cd:** NA **Repr Date:**05-APR-2011 **DIST(Mile):**58313
Cust Comments: C S NOISE FROM DRIVEBELT AREA
Tech Comments: CK AS NEC FOUND WORN AND LOOSE TENSIONER DAMAGED DRIVE BELT, REPL TENSIONER AND BELT

IFTWW31R28E [REDACTED] T/F7 F T/BC T/CD T/E A1 T/BE T/QL 02-APR-2008 02-JUL-2009 113955 USA 22 5G02 5C3Z 3B440 FFF F05 S10 V89 H25 42
AWS Claim Key: 7505973 **Doc #:** 06855856 **Trx Code:** P53 **Labor Hrs:** 3.7 **Labor Cost:** 358.24 **Material Cost:** 40.65 **Total Cost:** 398.89
Dir Cd-Sub Cd: 20681-* **Name:** DOWNS FORD, INC. **Ph:** 732-3492240 **St:** NJ **Ctry Cd:** USA **Reg Cd:** NA **Repr Date:**05-APR-2011 **DIST(Mile):**58313
Cust Comments: O S SAYS VEH PULLS LEFT
Tech Comments: CK AND VERIFIED, CK ALIGN, R&R NEC HARDWARE AND INST .5 CAMBER KIT IN LFT FRT TO SET TO ZERO, ROAD TEST STILL DRIFTS LEFT, DISASSEM AGAIN INST A ZERO KIT, RESET TOE IN ROAD TEST OK. MTIME EXTENSIVE DIAG AND CHECKING OF FRT END COMPONENTS AND ALIGN SETTINGS WITH FSE HOTLINE # 104491953

IFTWW31R28E [REDACTED] T/F7 F T/BC T/CD T/E A1 T/BE T/QL 02-APR-2008 02-JUL-2009 113955 USA 23 5V03 * 2B120 * F02 S10 V21 H07 69
AWS Claim Key: 7540512 **Doc #:** 07048551 **Trx Code:** 0968D **Labor Hrs:** 1.7 **Labor Cost:** 164.6 **Material Cost:** 322.79 **Total Cost:** 487.39
Dir Cd-Sub Cd: 20681-* **Name:** DOWNS FORD, INC. **Ph:** 732-3492240 **St:** NJ **Ctry Cd:** USA **Reg Cd:** NA **Repr Date:**06-MAY-2011 **DIST(Mile):**59765
Cust Comments: C S R F WHEEL LOCKS UP FREES UP AFTER SITTING
Tech Comments: CK AS NEC FOUND RGT FRT CALIPER SEIZED AND PADS BURNT, REPLACED BOTH FRT CALIPERS FOR PROPER BRAKE EQUALIZATION, REPL BRAKE PADS, MACHINED 2 RORORS BLEED SYSTEM ROAD TEST OK

IFTWW31R28E [REDACTED] T/F7 F T/BC T/CD T/E A1 T/BE T/QL 02-APR-2008 02-JUL-2009 113955 USA 24 5K06 * * * F09 SXX V00 * *
AWS Claim Key: 7665781 **Doc #:** 07169351 **Trx Code:** 11B24 **Labor Hrs:** .5 **Labor Cost:** 48.41 **Material Cost:** 0 **Total Cost:** 48.41
Dir Cd-Sub Cd: 20681-* **Name:** DOWNS FORD, INC. **Ph:** 732-3492240 **St:** NJ **Ctry Cd:** USA **Reg Cd:** NA **Repr Date:**26-MAY-2011 **DIST(Mile):**62480
Cust Comments: 11B24 CONTINENTAL TIRE RECALL INSPECTION
Tech Comments: PROG 11B24 CK FOUND VEH NEEDS 5 TIRES

IFTWW31R28E [REDACTED] T/F7 F T/BC T/CD T/E A1 T/BE T/QL 02-APR-2008 02-JUL-2009 113955 USA 24 5K06 * * * F09 SXX V00 * *
AWS Claim Key: 7665782 **Doc #:** 07169352 **Trx Code:** 11B24 **Labor Hrs:** 1.5 **Labor Cost:** 145.23 **Material Cost:** 1838.48 **Total Cost:** 1983.71
Dir Cd-Sub Cd: 20681-* **Name:** DOWNS FORD, INC. **Ph:** 732-3492240 **St:** NJ **Ctry Cd:** USA **Reg Cd:** NA **Repr Date:**26-MAY-2011 **DIST(Mile):**62480
Cust Comments: 11B24 CONTINENTAL TIRE RECALL REPLACEMENT
Tech Comments: PROG 11B24 REPLACED 5 TIRES

IFTWW31R28E [REDACTED] F7 T/F7 F T/BC T/CD T/E A1 T/BE T/QL 02-APR-2008 02-JUL-2009 113955 USA 24 5V03 * 2B120 * F02 S10 V21 H02 69
AWS Claim Key: 7676145 **Doc #:** 07279251 **Trx Code:** SPW **Labor Hrs:** 1.1 **Labor Cost:** 109.92 **Material Cost:** 114.51 **Total Cost:** 224.43
Dir Cd-Sub Cd: 20681-* **Name:** DOWNS FORD, INC. **Ph:** 732-3492240 **St:** NJ **Ctry Cd:** USA **Reg Cd:** NA **Repr Date:** 15-JUN-2011 **DIST(Mile):** 62498
Cust Comments: C S WAS DRIVING, RIGHT FRONT WHEEL STARTED SMOKING & PULLED RIGHT SPW
Tech Comments: RGT FRT CALIPER SEIZED BRAKE SHOES PAD ASSEMBLIES HYDRAULIC INSPECT

IFTWW31R28E [REDACTED] F7 T/F7 F T/BC T/CD T/E A1 T/BE T/QL 02-APR-2008 02-JUL-2009 113955 USA 25 2E03 * 9A543 * F04 S11 V52 D42 42
AWS Claim Key: 7890137 **Doc #:** 07465151 **Trx Code:** E72 **Labor Hrs:** 20.8 **Labor Cost:** 2078.34 **Material Cost:** 5429.34 **Total Cost:** 7507.68
Dir Cd-Sub Cd: 20681-* **Name:** DOWNS FORD, INC. **Ph:** 732-3492240 **St:** NJ **Ctry Cd:** USA **Reg Cd:** NA **Repr Date:** 18-JUL-2011 **DIST(Mile):** 64877
Cust Comments: TOWED TO SHOP NO POWER
Tech Comments: ROAD TEST VERIFIED CONCERN, PERF DIESEL DIAG. CODE P2291 P2297, PERF PWR BAL TEST CYLS 5&6 50 ON SCALE. CK FUEL SYSTEM FOUND METAL IN FUEL. CONTACT HOT LINE ADV TO REPL ALL INJECTORS & HIPRESS PUMP R&R NEC HARDWARE & CAB & R&R ADD ON RUNNING BOARDS, REPL HIPRESS PUMP & FUEL LINES & RAILS & FUEL COOLER R&R TANK AND CLEANED OUT, FLUSHED SYSTEM AS NEC PER WSM. REPL FILTERS & COOLER CLEARED CODES R

IFTWW31R28E [REDACTED] F7 T/F7 F T/BC T/CD T/E A1 T/BE T/QL 02-APR-2008 02-JUL-2009 113955 USA 25 5001 8C3Z 3504 CRM F02 S10 V87 H21 42
AWS Claim Key: 7890138 **Doc #:** 07465152 **Trx Code:** 0968D **Labor Hrs:** 2.5 **Labor Cost:** 249.8 **Material Cost:** 543.16 **Total Cost:** 792.96
Dir Cd-Sub Cd: 20681-* **Name:** DOWNS FORD, INC. **Ph:** 732-3492240 **St:** NJ **Ctry Cd:** USA **Reg Cd:** NA **Repr Date:** 18-JUL-2011 **DIST(Mile):** 64877
Cust Comments: C S EXCESSIVE PLAY IN STEERING
Tech Comments: CK AS NEC FOUND INTERNAL LOOSNESS IN GEAR, R&R NEC HARDWARE AND INST NEW GEAR, BLEED AIR FROM SYSTEM. ROAD TEST NOW STEERING WHEEL OFF CENTER, USING NEW GEAR, CK ALIGN RESET TOE IN

Any comments? You can contact



webmaster

Rpt. Analysis Home

Report Mgmt Primary

Report Mgmt Query

Report Mgmt

Indicator Summary

Help Exit

GCQIS Report Analysis

Report Summary

Report 2 of 3

Query Name: REPORT RETRIEVAL

Folder Number:

[File Report To This Folder](#)

[File Report To A Folder](#)

[Add Comments](#)

[Previous](#)

[Next](#)

[Save](#)

[Mail Report](#)

[Download Options](#)

Report Detail Section : [View Details](#)

 [Attachments: 0](#)

Report# :	BDKEA002 NHL	Received:	04/11/2011
CCRG/EPRC:		Date:	
Vehicle:	2008,F350 4X4 ,F350 ,CRW CAB,PICKUP ,1FTWW31R28E 	Build Date:	04/02/2008
Odometer :	58,313 M	Engine:	6.4L OHV
Transmission:	5R110W DSL	Axle:	
Dealer:	USA 20681 Downs Ford, Inc.	Calibration:	8F716A0A
City:	Toms River	A/C:	YES
Originator:	JOE PATI	Phone#:	(732) 349-2240
Symptom:	6 62 3 00 SP/ST/RD,STEER/STER WHL,FEEL/WAN/PULL,UNKNOWN		
Status:			
VFG:	V87 STEERING		
Additional Symptom:	SINCE NEW		
Fix:	Causal Component :		
Condition Code:			

Hotliner: JELLERH2

Phone:

Regn Cd: N1 New York

Engineering:

Phone:

TAR:

Dir Contact: JOE PATI

Phone: 732 349-2240

Title Cde: SM

KOEO:**KOEC:****KOER:****Comments:**

REPAIR 04/11/2011 03:23PM JELLERH2
WEB FORM DATA - CONCERN: VEHICLE DRIFTS TO LEFT W/ DRIVING, CONCERN PRESENT SINCE BRAND NEW PER CUSTOMER. DEALER & FSE FOUND LEFT SIDE UPPER AND LOWER BALL JOINT LOOSE. REPLACED AS NEC. VEHICLE PULLS TO THE LEFT EVEN AFTER ALIGNMENT, SPECS BELOW. DIAGNOSTICS: PERFORMED ALIGNMENT, READINGS AS FOLLOWS: FRONT CASTER LEFT 2.1, RIGHT CASTER 1.9, CAMBER LEFT .5, CAMBER RIGHT .0, TOE LEFT .0, TOE RIGHT .10, TOTAL .10 . REAR : LEFT CAMBER 0., RIGHT CAMBER -.2, TOE LEFT .10, TOE RIGHT -.05, TOTAL .05. THRUST ANGLE -.01 PARTS REPLACED:: LEFT SIDE UPPER AND LOWER BALL JOINTS TECH QUESTION: SEEKING SUGGESTIONS AS TO HOW TO REPAIR VEHICLE WITHOUT ADJUSTING THE FRONT END OUT OF SPEC. SEEKING KNOWN CONCERNS ALSO. FSE INVOLVED.
THANKS. WERE YOU ABLE TO VERIFY THE CONCERN? YES IS THERE AN APPROPRIATE PINPOINT TEST IN THE WSM FOR THIS CONCERN? NO WAS THE PINPOINT TEST FOLLOWED? NO BODY CONVERSION: NONE

RECOMM 04/11/2011 03:23PM JELLERH2

██████████, BASED ON THE INFORMATION PROVIDED WE CAN RECOMMEND THE FOLLOWING COURSE OF ACTION. PLEASE DON'T BE OFFENDED BY ANY OF THESE RECOMMENDATIONS AS THEY ARE NOT LISTED AS BEING PERFORMED. CROSS THE FRONT TIRES FROM SIDE TO SIDE AND RE-DRIVE, IF THE DRIFT TO LEFT IS NOW TO RIGHT THIS IS A TIRE ISSUE. IF THE PULL IS THE SAME DRIVE THE VEHICLE UNTIL HOT AND CHECK FOR POSSIBLE BRAKE DRAG CAUSING THE CONCERN. WHILE THE VEHICLE IS ON THE ALIGNMENT RACK TURN PLATES START THE VEHICLE AND OBSERVE THE STEERING WHEEL IF THE STEERING WHEEL TURNS SLIGHTLY TO LEFT WHILE OBSERVING SEVERAL STARTS SUSPECT THE STEERING GEAR IS AT FAULT. IF YOU NEED FURTHER ASSISTANCE FROM THE TECHNICAL HOTLINE OR THE FSE PLEASE CALL THE TECHNICAL HOTLINE FOR

ASSISTANCE.

REPAIR 04/11/2011 05:31PM JASON TAYLOR MSS - FCSD - TECH SVC HOTLINE
TECHNICIAN REPLY: SWAPED TIRES FROM SIDE TO SIDE BEFORE CONTACTING YOU, FORGOT TO ADD THAT, PERFORMED CHECK ON TURN PLATES AS SUGGESTED, WHEEL STAYS STRAIGHT

RECOMM 04/11/2011 05:31PM JASON TAYLOR MSS - FCSD - TECH SVC HOTLINE
[REDACTED] WITH THE ALIGNMENT READINGS PROVIDED SUGGEST ADJUSTING THE LEFT FRONT CAMBER TO AS CLOSE TO 0 AS POSSIBLE AND SEE IF THE CONCERN IS STILL PRESENT. IF THE CONCERN IS STILL PRESENT THEN SUGGEST INCREASING THE CASTER ON THE LEFT FRONT OF THE VEHICLE AS CLOSE TO THE NOMINAL SETTING WHICH IS 2.7. THEN TAKE THE VEHICLE FOR A TEST DRIVE AND SEE IF THE CONCERN IS STILL PRESENT.

AUDIT 07/02/2011 11:05AM
SYMPTOM 3 03 2 89 CHANGED TO 6 62 3 00 BY CS012093

Folder Number:

File Report To This Folder

File Report To A Folder

Download Options

Add Comments

Previous

Next

Save

Mail Report

Requester: RHERRO11
Report Summary
Server: FCWS686

Ford Proprietary, Private

2-Dec-2011
Retention: None



1
2
3
4
5
6
7
8
9
10
11
12
13
14
15
16
17
18
19
20
21
22
23
24
25

FILED

2011 SEP 12 P 2:21

J. DEPLY A. ALLEN
GRANT COUNTY CLERK

SUPERIOR COURT OF WASHINGTON IN AND FOR GRANT COUNTY

[REDACTED] a single person,

Plaintiff,

NO. [REDACTED]

v.

COMPLAINT FOR MONEY
JUDGMENT

CROSSROADS AUTOMOTIVE GROUP,
INC., a Washington corporation, d/b/a
DISCOVERY FORD LINCOLN
MERCURY; and FORD MOTOR
COMPANY, a foreign corporation,

Defendants.

COMES NOW Plaintiff, [REDACTED], by and through his attorneys of
record, Larson Fowles, PLLC, and for cause of action against the above-named
Defendant complains, alleges, and avers the following:

I. JURISDICTION AND VENUE

1.1 This is an action for, *inter alia*, fraud, misrepresentation, breach of
warranty and Consumer Protection Act violations, and thus falls within the legal and
equitable jurisdiction of this Court.

1.2 Venue for this action is properly before this Court for the reason that

COMPLAINT FOR MONEY JUDGMENT: 1

COPY

LARSON FOWLES, PLLC
821 EAST BROADWAY AVENUE, STE. 8
Moses Lake, WA 98837
Telephone: (509) 765-6700
Fax: (509) 765-6710

1 Defendant, Crossroads Automotive Group, Inc., d/b/a Discover Ford Lincoln Mercury,
2 is principally located and conducts business in Grant County, Washington, and
3 Defendant Ford Motor Company, a foreign corporation, also conducts business in
4 Grant County, Washington.

5 **II. PLAINTIFF**

6 2.1 Plaintiff [REDACTED] hereinafter "[REDACTED]"), is a single
7 person, residing in Moses Lake, Grant County, Washington.

8 **III. DEFENDANTS**

9 3.1 Defendant, Crossroads Automotive Group, Inc., d/b/a Discovery Ford
10 Lincoln Mercury (hereinafter "Discovery Ford"), is a Washington corporation, duly
11 licensed to conduct business in the State of Washington, and principally located in
12 Moses Lake, Grant County, Washington. Discovery Ford is liable for all acts or
13 omissions of its employees acting in the course and scope of their employment.

14 3.2 Defendant, Ford Motor Company, is a foreign corporation, duly licensed
15 to conduct business in the State of Washington, and principally located in Dearborn,
16 Michigan.

17 **IV. FACTUAL ALLEGATIONS**

18 4.1 In approximately August, 2007, [REDACTED] leased a '08 Ford F-350
19 pickup truck from Broadway Ford in Idaho Falls, Idaho.

20 4.2 Broadway Ford represented that the vehicle was covered by Ford Motor
21 Company's full 36,000 mile "bumper-to-bumper" factory warranty (hereinafter the
22 "warranty"). Broadway Ford additionally represented that the warranty would be
23 honored at any Ford dealership, including at Discovery Ford, the dealership located in
24 [REDACTED] hometown of Moses Lake, Washington.

25
COMPLAINT FOR MONEY JUDGMENT: 2

LARSON FOWLES, PLLC
821 EAST BROADWAY AVENUE, STE. 8
Moses Lake, WA 98837
Telephone: (509) 765-6700
Fax: (509) 765-6710

1 4.3 With these assurances, Mr. [REDACTED] leased the truck with a capitalized
2 cost of \$58,095, of which \$53,095 was financed. Mr. [REDACTED] took possession of the
3 vehicle on or around August 18, 2007, and soon returned to Moses Lake.

4 4.4 Mr. [REDACTED] began experiencing problems with the truck almost at the
5 outset of the lease. Discovery Ford thus installed a cooling system (per a recall), and
6 reprogrammed the vehicle (per a recall), for Mr. [REDACTED]

7 4.5 On or around September 28, 2008, Mr. [REDACTED] was driving the truck
8 in and around Moses Lake, when he noticed the truck began to drive "sloppy," making
9 it difficult to keep the truck on the road. He took the vehicle to Discovery Ford for
10 repair.

11 4.6 On or around September 29, 2008, Discovery Ford represented to Mr.
12 [REDACTED] that there were problems with the steering gear and drag link, which they
13 determined were caused by a lift kit that had been installed on the truck by Broadway
14 Ford.

15 4.7 Discovery Ford informed Mr. [REDACTED] that because the lift kit Broadway
16 Ford had installed was the source of the driving problems, Ford Motor Company would
17 not honor the warranty.

18 4.8 Discovery Ford and Ford Motor Company ultimately denied warranty
19 coverage for the repairs to Mr. [REDACTED] truck on the basis that the after-market
20 parts voided the warranty.

21 4.9 Ford Motor Company represented to Mr. [REDACTED] personally that it
22 stood behind the decision of Discovery Ford to deny warranty coverage because the
23 installation of the after-market, non-Ford parts voided the warranty.

24 4.10 Broadway Ford then refused to pay for or otherwise assist Mr. [REDACTED]
25 in repairing the vehicle.

26 4.11 Although the truck was inoperable, Mr. [REDACTED] did his best to make
27 the monthly lease payments and to maintain insurance on the truck for a period of
28 eight (8) months, before electing to revoke acceptance of the truck under Idaho law.

COMPLAINT FOR MONEY JUDGMENT: 3

LARSON FOWLES, PLLC
821 EAST BROADWAY AVENUE, STE. 8
MOSES LAKE, WA 98837
Telephone: (509) 765-6700
Fax: (509) 765-6710

1 Unable to afford a truck he could not drive, Mr. [REDACTED] voluntarily surrendered the
2 truck to his lender, U.S. Bank, in approximately July, 2009.

3 4.12 At the time Mr. [REDACTED] surrendered the vehicle to U.S. Bank, the truck
4 had less than 36,000 miles.

5 4.13 Ironically, Discovery Ford purchased the truck, previously leased by Mr.
6 [REDACTED] and still in disrepair, at an auto auction near Spokane, Washington, in
7 approximately September, 2009.

8 4.14 In approximately November, 2009, Discovery Ford sold the truck to a
9 relative of one of its employees.

10 4.15 In doing so, Discovery Ford this time made the same repairs Mr.
11 [REDACTED] sought to have performed on the vehicle in September, 2008, and covered
12 the repairs under the warranty for the relative of the Discovery Ford employee who
13 purchased the truck.

14 4.16 Ford Motor Company this time approved the same repairs Mr. [REDACTED]
15 sought to have performed on the vehicle in September, 2008, and covered the repairs
16 under its warranty for the relative of the Discovery Ford employee who purchased the
17 truck.

18 4.17 At no time did Discovery Ford or Ford Motor Company ever attempt to
19 contact Mr. [REDACTED] to inform him that the repairs he sought to have performed on
20 his truck, were, in fact, coverable under the warranty, after Defendants denied
21 warranty coverage as to him in September, 2008.

22 4.18 Mr. [REDACTED] first learned in approximately April, 2010, that Discovery
23 Ford and Ford Motor Company had honored the warranty as to, and repaired the truck
24 for, the relative of the Discovery Ford employee who purchased the truck.

25 4.19 U.S. Bank ultimately sued Mr. [REDACTED] in Idaho for the shortfall under
their lease agreement (hereinafter the "Idaho lawsuit"). Mr. [REDACTED] has incurred
damages, attorney's fees and costs as a result of Defendants' acts or omissions
alleged hereinabove, and the subsequent, incidental, Idaho lawsuit.

COMPLAINT FOR MONEY JUDGMENT: 4

LARSON FOWLES, PLLC
821 EAST BROADWAY AVENUE, STE. 8
Mosier Lake, WA 98837
Telephone: (509) 765-6700
Fax: (509) 765-6710

1 4.20 Mr. [REDACTED] credit has been adversely affected as a result of
2 Defendants' acts or omissions alleged hereinabove, and the subsequent, incidental,
3 Idaho lawsuit, preventing him from financing a home or another vehicle.

4 4.21 Mr. [REDACTED] has incurred attorney's fees and costs in pursuit of this
5 action.

6 **V. FIRST CAUSE OF ACTION—FRAUD**

7 5.1 Mr. [REDACTED] re-alleges the preceding paragraphs.

8 5.2 The acts or omissions of Defendants constitute fraud.

9 5.3 The representations made by Defendants described hereinabove were
10 material and false when made, and Defendants knew they were false, in that the
11 repairs Mr. [REDACTED] sought to be performed on his truck were, in fact, coverable
12 under the warranty.

13 5.4 Defendants made the representations described hereinabove with the
14 intent and for the purpose of denying warranty coverage as to Mr. [REDACTED] and
15 instead inducing Mr. [REDACTED] into paying for the cost of the repairs out of his own
16 pocket.

17 5.5 Mr. [REDACTED] was unaware of the falsity of these representations and
18 reasonably relied on the same in deciding not to have his truck repaired and instead
19 pursuing the option of revocation of acceptance of the vehicle in the Idaho lawsuit.

20 5.6 As a direct and proximate result of the conduct of Defendants as
21 described hereinabove, Mr. [REDACTED] has incurred damages in an amount to be
22 proven at trial.

23 **VI. SECOND CAUSE OF ACTION—NEGLIGENT MISREPRESENTATION**

24 6.1 Mr. [REDACTED] re-alleges the preceding paragraphs.

25 6.2 The acts or omissions of Defendants constitute negligent
misrepresentation.

COMPLAINT FOR MONEY JUDGMENT: 5

LARSON FOWLES, PLLC
821 EAST BROADWAY AVENUE, STE. 8
Moses Lake, WA 98837
Telephone: (509) 765-0700
Fax: (509) 765-6710

1 6.3 Defendants supplied false information to Mr. [REDACTED] which
2 information they knew or should have known was intended to guide Mr. [REDACTED] in
3 his business transactions.

4 6.4 Defendants were negligent in the manner in which they obtained or
5 communicated the false information.

6 6.5 Mr. [REDACTED] reasonably relied on the false information, and as a direct
7 and proximate result of his reliance, has suffered damages in an amount to be proven
8 at trial.

9 **VII. THIRD CAUSE OF ACTION—BREACH OF FIDUCIARY DUTY**

10 7.1 Mr. [REDACTED] re-alleges the preceding paragraphs.

11 7.2 The facts and circumstances as alleged herein give rise to a quasi-
12 fiduciary relationship in-fact between Defendants and [REDACTED] and the acts or
13 omissions of Defendants constitute a breach of the fiduciary duty the Defendants owed
14 to Mr. [REDACTED]

15 7.3 As manufacturer, warrantor, and dealer interpreting the manufacturer's
16 warranty, Defendants were in a superior position to Mr. [REDACTED] such that Mr.
17 [REDACTED] justifiably expected Defendants to care for his welfare in handling the
18 warranty issue.

19 7.4 Defendants breached said duty owed to Mr. [REDACTED] by, without
20 limitation, failing to honor the warranty, or notifying Mr. [REDACTED] that the repairs were
21 in fact coverable under the warranty, and instead covering the repairs under the
22 warranty for, and then selling the truck to, a relative of an employee of Defendant
23 Discovery Ford.

24 7.5 As a direct and proximate result of Defendants' breach of said fiduciary
25 duty, Mr. [REDACTED] has suffered damages in an amount to be proven at trial.

1
2 **VIII. VIOLATION OF WASHINGTON'S CONSUMER PROTECTION ACT, RCW**
3 **19.86 et. seq.**

4 8.1 Mr. [REDACTED] re-alleges the preceding paragraphs.

5 8.2 The acts or omissions of Defendants violate RCW 46.70.180 and thus
6 constitute a *per se* violation of Washington's Consumer Protection Act, RCW 19.86 *et.*
7 *seq.*

8 8.3 Mr. [REDACTED] is within the class of people RCW 46.70.180 is meant to
9 protect.

10 8.4 As a direct and proximate result of Defendants' violation of RCW
11 46.70.180, Mr. [REDACTED] has suffered damages in an amount to be proven at trial.

12 8.5 Alternatively, the acts or omissions of Defendants constitute an unfair or
13 deceptive act or practice occurring in trade or commerce, which impacts the public
14 interest.

15 8.6 As a direct and proximate result of Defendants conduct, Mr. [REDACTED]
16 has incurred damages to his business or property in an amount to be proven at trial.

17 **IX. FOURTH CAUSE OF ACTION—EQUITABLE INDEMNITY**

18 9.1 Mr. [REDACTED] re-alleges the preceding paragraphs.

19 9.2 The acts or omissions of Defendants give rise to equitable indemnity on
20 the part of Defendants.

21 9.3 Defendants' conduct was wrongful toward Mr. [REDACTED].

22 9.4 Defendants' wrongful conduct toward Mr. [REDACTED] exposed Mr.
23 [REDACTED] to litigation with a third party.

24 9.5 The third party had no connection with the initial transaction between
25 Defendants and Mr. [REDACTED]

COMPLAINT FOR MONEY JUDGMENT: 7

LARSON FOWLES, PLLC
821 EAST BROADWAY AVENUE, STE. 8
MOSES LAKE, WA 98837
Telephone: (509) 766-6700
Fax: (509) 765-6710

1 9.6 As a direct and proximate result of Defendants' conduct alleged herein,
2 Mr. [REDACTED] has incurred damages in an amount to be proven at trial, and
3 Defendants should be required to indemnify Mr. [REDACTED] for said damages.

4
5 **X. FIFTH CAUSE OF ACTION—VIOLATION OF RCW 62A.2-313—**
6 **BREACH OF EXPRESS WARRANTY**

7 10.1 Mr. [REDACTED] re-alleges the preceding paragraphs.

8 10.2 The acts or omissions of Defendants constitute a breach of an express
9 warranty.

10 10.3 As a direct and proximate result of Defendants' failure to honor the
11 express warranty as to Mr. [REDACTED], Mr. [REDACTED] has incurred damages in an
12 amount to be proven at trial.

13 **XI. SIXTH CAUSE OF ACTION—VIOLATION OF RCW 62A.2-314—BREACH OF**
14 **IMPLIED WARRANTY OF MERCHANTABILITY**

15 11.1 Mr. [REDACTED] re-alleges the preceding paragraphs.

16 11.2 The acts or omissions of Defendants constitute a breach of the implied
17 warranty of merchantability.

18 11.3 Mr. [REDACTED] was in contractual privity with Defendants, or was a third-
19 party beneficiary of any contract between Defendants.

20 11.4 As a direct and proximate result of Defendants' failure to honor the
21 warranty as to Mr. [REDACTED] Mr. [REDACTED] has incurred damages in an amount to be
22 proven at trial.

23 **XII. SEVENTH CAUSE OF ACTION—BREACH OF IMPLIED DUTY OF GOOD**
24 **FAITH AND FAIR DEALING**

25 12.1 Mr. [REDACTED] re-alleges the preceding paragraphs.

1 12.2 The acts or omissions of Defendants constitute a breach of Defendants'
2 implied duty of good faith and fair dealing.

3 12.3 As a direct and proximate result of Defendants' breach, Mr. [REDACTED]
4 has incurred damages in an amount to be proven at trial.

5 **XIII. PRAYER FOR RELIEF**

6 WHEREFORE, Mr. [REDACTED] prays for the following relief:

7 13.1 For judgment in his favor and against Defendants, Discovery Ford and
8 Ford Motor Company, jointly and severally, for all monetary damages, including costs,
9 expenses, and attorney's fees, incurred herein.

10 13.2 For judgment in his favor and against Defendants, Discovery Ford and
11 Ford Motor Company, jointly and severally, for all monetary damages, including costs,
12 expenses, and attorney's fees, incurred herein, and any other remedies available to
13 buyers pursuant to RCW 62A.2 *et seq.*

14 13.3 For an award of treble damages and attorney's fees and costs incurred
15 herein against Defendants, Discovery Ford and Ford Motor Company, jointly and
16 severally, pursuant to RCW 19.86 *et. seq.*

17 13.4 For indemnification against Defendants, Discover Ford and Ford Motor
18 Company, jointly and severally, for all monetary damages incurred in the Idaho
19 lawsuit, including costs, expenses, and attorney's fees.

20 13.5 For such other and further relief as the Court may deem just and
21 equitable.
22
23
24
25

1
2
3
4
5
6
7
8
9
10
11
12
13
14
15
16
17
18
19
20
21
22
23
24
25

DATED this ____ day of September, 2011.

LARSON FOWLES, PLLC

[Handwritten signature] #35457

DWAYNE C. FOWLES, WSBA #27119
MITCHELL J. HEAPS, WSBA #35457
Attorneys for Plaintiff Tanner Mickelsen

COMPLAINT FOR MONEY JUDGMENT: 10

LARSON FOWLES, PLLC
821 EAST BROADWAY AVENUE, STE. 8
Moses Lake, WA 98837
Telephone: (509) 785-6700
Fax: (509) 785-6710

All Action Details for Issue

[Print](#)

VIN: 1FTWW31RX8E [REDACTED] Year: 2008 Model: F-SERIES SUPER DUTY Case: 520502758
Name: [REDACTED] Owner Status: Original WSD: 2007-08-18
Symptom Desc: Primary Phone: [REDACTED]
Reason Desc: TECHNICAL INQUIRY - RESEARCH REQUEST Secondary Phone: [REDACTED]
Issue Type: 01 INQUIRY Issue Status: CLOSED

Action: CB-ADVISE CUSTOMER OF CLOSING COMMENTS

Dealer:

Odometer: 1 MI

Analyst Name: ALBERT (NALBERT3),NICOLE

Action Date: 04/13/2010

Comm Type: PHONE

Analyst: NALBERT3

Action Time: 19.22.44.254 Action Data: No

Origin Desc: US INQUIRY CASE BASE

Comments CUSTOMER SAID: -CUSTOMER CALLED TO SEE IF HE COULD GET COPY (RECORDED) ISSUE HE CALLED ON: 10-01-2008-INVOLVED IN A LAWSUIT WITH THE DEALER-WANTED TO KNOW IF IT WAS RECORDED/DOCUMENTED THAT: HIS VEHICLE WARRANTY WAS VOIDEDDEALER SAID: -DISCOVERY FORD1140 S. PIONEER WAYMOSES LAKE WA 98837(509) 765-4551CRC ADVISED: ""I HAVE REVIEWED YOUR FILE AND I CAN ADVISE YOU OF THE FOLLOWING: (NOTE TO CSR: REVIEW HISTORICAL INFORMATION AND PROVIDE CUSTOMER WITH SUMMARY OF INFORMATION/ACTIONS TAKEN)""-INFORMED CUSTOMER ALL CALLS ARE RECORDED -HIS ATTORNEY/LAWYER WOULD HAVE TO CALL AND REQUEST (INFORMATION) THEY NEED -PER NOTES IN CUDL: 10/01/2008-COMMENTS CUSTOMER SAID: 1. VEH WANDERS ALL OVER THE ROAD-HAS HAD MULTIPLE CONCERNS WITH VEH-RADIATOR HAS GONE OUT TWICE PREVIOUSLY AND WAS COVERED UNDER WARRANTY-STEERING BOX GONE OUT AND DLR SAYS THE VEH WARRANTY IS VOIDED BECAUSE THERE ARE LIFTS ON THE VEH-DLR THAT SOLD THE VEH TO CUST VOIDED THE WARRANTY BEFORE CUST BOUGHT THE VEH BECAUSE THEY SOLD IT TO HIM WITH AFTERMARKET PARTS ON IT

Ford Confidential

All Action Details for Issue

[Print](#)

VIN: 1FTWW31RX8E [REDACTED] Year: 2008 Model: F-SERIES SUPER DUTY Case: 520502758
Name: MF [REDACTED] Owner Status: Original WSD: 2007-08-18
Symptom Desc: STRG/HANDLING PULL/DRIFT LEFT AND RIGHT Primary Phone: [REDACTED]
Reason Desc: CLP - IN - FIN ASSIST - MULTIPLE REPAIRS Secondary Phone: [REDACTED]
Issue Type: 04 REGION Issue Status: CLOSED
Initial Customer Contact: 10/02/2008

Action: TIER II ESCALATION
Dealer: 01170 DISCOVERY FORD LINCOLN Origin Desc: US CONCERN CASE BASE
Odometer: 24000 MI Comm Type: PHONE
Analyst Name: SHEIR (JSHEIR1),JAYMIE Analyst: JSHEIR1
Action Date: 10/01/2008 Action Time: 14.35.50.967 Action Data: No

Comments CUSTOMER SAID: 1. VEH WANDERS ALL OVER THE ROAD-HAS HAD MULTIPLE CONCERNS WITH VEH- RADIATOR HAS GONE OUT TWICE PREVIOUSLY AND WAS COVERED UNDER WARRANTY-STEERING BOX GONE OUT AND DLR SAYS THE VEH WARRANTY IS VOIDED BECAUSE THERE ARE LIFTS ON THE VEH-DLR THAT SOLD THE VEH TO CUST VOIDED THE WARRANTY BEFORE CUST BOUGHT THE VEH BECAUSE THEY SOLD IT TO HIM WITH AFTERMARKET PARTS ON IT-PURCHASED THE VEH IN IDAHO FALLS FROM BROADWAY FORD-VEH IS AT HOME BECAUSE HE DOES NOT WANT TO BE CHARGED STORAGE FEES-IDAHO FALLS IS TELLING CUST THAT IT IS NOT THEIR PROBLEM-WOULD NEVER HAD BOUGHT THE VEH IF HE KNEW THAT THE LIFT KIT VOIDED THE WARRANTY-WANTS FORD TO BUY BACK THE VEHDEALER SAID: -DLR THAT SOLD THE VEH TO CUST VOIDED THE WARRANTY BEFORE CUST BOUGHT THE VEH BECAUSE THEY SOLD IT TO HIM WITH AFTERMARKET PARTS ON ITDISCOVERY FORD1140 S. PIONEER WAY MOSES LAKE, WA 98837TEL:(509) 765-4551S/M LEO-IDAHO FALLS DLRIS TELLING CUST THAT IT IS NOT THEIR PROBLEMCRRC ADVISED: I WILL ESCALATE THIS TO OUR CUSTOMER CARE SOLUTIONS TEAM. A SPECIALIST WILL CONTACT YOU WITHIN 2 BUSINESS DAYS.CUST CONTACT NUMBER: [REDACTED]

Action: DOCUMENT ADDITIONAL INFORMATION
Dealer: 01170 DISCOVERY FORD LINCOLN Origin Desc: CUSTOMER CARE SOLUTIONS TEAM
Odometer: 24000 MI Comm Type: PHONE
Analyst Name: CRUZ,MELISSA Analyst: MCRUZ54
Action Date: 10/02/2008 Action Time: 15.12.34.171 Action Data: No

Comments CCS MELISSA, X 7424 ***CASE REVIEW*** NO ESP ON FILE/OPEN SAFETY COMPLIANCE RECALL 08C01 (FRONT DRIVER'S SEAT BACK INSPECTION AND REPAIR) - ONLY VEH ON FILE, RETAIL SALE AND ORIGINALLY OWNED - UNABLE TO REVIEW ANY REPAIR HISTORY IN AWS - PER OASIS, 2/8/08 AT 15,346 MI AND 10/26/07 AT 9,545 MI (RADIATOR REPLACEMENT) - OBC TO DLR AT 509-765-4551 - VEH NOT IN SHOP, CUST PICKED UP - CONCERN WITH VEH ATTRIBUTED TO AFTERMARKET LIFT KIT

Action: CONCERN ADDRESSED
Dealer: 01170 DISCOVERY FORD LINCOLN Origin Desc: CUSTOMER CARE SOLUTIONS TEAM
Odometer: 24000 MI Comm Type: PHONE
Analyst Name: CRUZ,MELISSA Analyst: MCRUZ54
Action Date: 10/02/2008 Action Time: 15.25.33.638 Action Data: No

Comments CCS MELISSA, X 7424 - VEH PURCHASED FROM BROADWAY FORD, 208-525-8500 +++ OBC TO CUST AT [REDACTED] ADVISED CUST I AM CALLING REGARDING HIS REQUEST FOR A BUYBACK - ADVISED CUST OF MY CONVERSATION WITH SRV REP - CUST CONFIRMED HE PICKED VEH UP - STATES WHEN HE PURCHASED VEH FROM BROADWAY FORD, HE WAS ADVISED IT WAS FULLY-WARRANTIED - I ASKED CUST IF HE WAS PROVIDED DOCUMENTATION SUPPORTING THAT AND HE SAID THEY DIDN'T, THAT HE WAS UNDER ASSUMPTION FULLY WARRANTIED - STATES HE NO LONGER WANTS VEH - STATES HE PURCHASED VEH FROM DLR LIKE THIS - ADVISED CUST WE WILL NOT BE ABLE TO BUYBACK HIS VEH - ADVISED CUST AFTERMARKET COMPONENTS DO NOT VOID WARR - ADVISED IF AFTERMARKET COMPONENTS ARE THE CAUSE OF FAILURE OR DAMAGE TO A

CERTAIN COMPONENT, THEN BTB WARR WIL NOT COVER IT - ADVISED CUST HE NEEDS TO TAKE THIS UP WITH SELLING DLR - CUST ADVISED HE TRIED AND THEY STATED IT WAS NOT THEIR PROBLEM AND THAT THEY'RE NOT DOING ANYTHING ABOUT IT - PROVIDED CUST MY CONTACT INFO AND CASE NUMBER - ADVISED CUST TO CONTACT ME IF HE HAS ANY QUESTIONS - CUST ADVISED HE WILL BE CONTACTING AN ATTY - NO FURTHER ACTION REQUIRED

Ford Confidential

All Action Details for Issue

[Print](#)

VIN: 1FTWW31RX8[REDACTED] Year: 2008 Model: F-SERIES SUPER DUTY Case: 520502758
Name: [REDACTED] Owner Status: Original WSD: 2007-08-18
Symptom Desc: STRG/HANDLING PULL/DRIFT LEFT AND RIGHT Primary Phone: [REDACTED]
Reason Desc: CLP - IN - FIN ASSIST - OBC Secondary Phone: [REDACTED]
Issue Type: 01 INQUIRY Issue Status: CLOSED

Action: REPAIR - SUPPORT DEALER DENIAL
Dealer: 01170 DISCOVERY FORD LINCOLN Origin Desc: US CONCERN CASE BASE
Odometer: 24000 MI Comm Type: PHONE
Analyst Name: SHEIR (JSHEIR1),JAYMIE Analyst: JSHEIR1
Action Date: 10/01/2008 Action Time: 14.27.29.258 Action Data: No

Comments CUSTOMER SAID: 1. VEH WANDERS ALL OVER THE ROAD-HAS HAD MULTIPLE CONCERNS WITH VEH-
RADIATOR HAS GONE OUT TWICE PREVIOUSLY-STEERING BOX GONE OUT AND DLR SAYS THE VEH WARRANTY
IS VOIDED BECAUSE THERE ARE LIFTS ON THE VEH-DLR THAT SOLD THE VEH TO CUST VOIDED THE
WARRANTY BEFORE CUST BOUGHT THE VEH BECAUSE THEY SOLD IT TO HIM WITH AFTERMARKET PARTS ON
IT-PURCHASED THE VEH IN IDAHO FALLS FROM BROADWAY FORD-VEH IS AT HOME BECAUSE HE DOES NOT
WANT TO BE CHARGED STORAGE FEES-IDAHO FALLS IS TELLING CUST THAT IT IS NOT THEIR PROBLEM-CUST
WANTS VEH TO BE UNDER WARRANTY-WANTS FIN ASSTDEALER SAID: -DLR THAT SOLD THE VEH TO CUST
VOIDED THE WARRANTY BEFORE CUST BOUGHT THE VEH BECAUSE THEY SOLD IT TO HIM WITH AFTERMARKET
PARTS ON ITDISCOVERY FORD1140 S. PIONEER WAY MOSES LAKE, WA 98837TEL:(509) 765-4551S/M LEOCR
ADVISED: AFTER REVIEWING THE SITUATION WITH YOUR SERVICE MANAGER, THERE ARE NO WARRANTIES OR
OTHER COVERAGE AVAILABLE THAT WOULD PROVIDE ASSISTANCE. WE SUPPORT THE DECISION MADE BY THE
DEALERSHIP.-ADVISED CUST THAT FORD DOES NOT PUT LIFT KITS ON THE VEH AT THE MFG PLANT THIS
WOULD HAVE BEEN DONE AT THE DLRSHIP-ADVISED CUST TO CONTACT SELLING DLRSHPDISCOVERY
FORD1140 S. PIONEER WAY MOSES LAKE, WA 98837TEL:(509) 765-4551S/M LEOW/A LAURENBROADWAY FORD
INC980 WEST BROADWAY IDAHO FALLS, ID 83402TEL:(208) 525-8500

Ford Confidential

Server: AWS Prod
 Claims loaded through: 22-SEP-2011

STANDARD CLAIMS LIST

AWS Online Report

Run Date: 23-SEP-11

Note: All Costs are in US Dollars Server Name: AWS Prod Claims loaded through

VIN	AWS VL	WERS VL	MKT DER	BODY CAB	VER SERIES	DRIVE TYPE	PLANT CD	TRANS CD	ENG COD	PROD DATE	WARR DATE	SELLING DEALER	SELL CNT	TIS	WCC	PREF	BASE	SUFF	VRT NA	VRT ROW	VFG	CCC	CD
IFTWW31RX8E[REDACTED]	F7	T/F7	F	T/BC	T/CD	T/E	A1	T/BE	T/QL	18-05-07	18-08-07	156078	USA	3	1F01	8C3Z	8009	B	F04	S11	V44	L85	42
AWS Claim Key:	<u>215281</u>	Doc #:	14077301	Trx Code:	2	Labor Hrs:	3.4	Labor Cost:	268.4	Material Cost:	484.63	Total Cost:	753.03										
Dir Cd-Sub Cd:	01170-*	Name:	DISCOVERY FORD LINCOLN	Ph:	509-7654551	St:	WA	Ctry Cd:	USA	Reg Cd:	NA	Repr Date:	26-OCT-07	DIST(Mile):	9545								
Cust Comments:	CUSTOMER STATES HAS FLUID LEAKING ENGINE AREA.																						
Tech Comments:	VERIFIED CONCERN PRESSURE TESTED COOLING SYSTEM FOUND RADIATOR LEAKING R&R RADIATOR. EVAC & RECHARGED A/C. BLED COOLING & FUEL SYSTEMS. RECHECKED ALL OK.																						
IFTWW31RX8E[REDACTED]	F7	T/F7	F	T/BC	T/CD	T/E	A1	T/BE	T/QL	18-05-07	18-08-07	156078	USA	6	1F01	8C3Z	8009	B	F04	S11	V44	L65	42
AWS Claim Key:	<u>588830</u>	Doc #:	14351101	Trx Code:	E84	Labor Hrs:	3.4	Labor Cost:	268.4	Material Cost:	556.39	Total Cost:	824.79										
Dir Cd-Sub Cd:	01170-*	Name:	DISCOVERY FORD LINCOLN	Ph:	509-7654551	St:	WA	Ctry Cd:	USA	Reg Cd:	NA	Repr Date:	08-FEB-08	DIST(Mile):	15346								
Cust Comments:	CUSTOMER STATES THERE IS AN OIL LEAK BY THE RADIATOR.																						
Tech Comments:	VERIFIED COOLANT LEAK. PRESSURE TESTED COOLING SYSTEM FOUND & REPAIRED LEAK AT UPPER EGR COOLER LOWER HOSE (TIGHTENED CLAMP). RETESTED LH SIDE TANK ON RADIATOR LEAKING. EVACUATED A/C. R&R RADIATOR RECHARGED A/C. RECHECKED OK.																						
IFTWW31RX8E[REDACTED]	F7	T/F7	F	T/BC	T/CD	T/E	A1	T/BE	T/QL	18-05-07	18-08-07	156078	USA	12	6Y20 *	TAP5 *	F09	SXX	V99	A99	82		
AWS Claim Key:	<u>1387480</u>	Doc #:	14990503	Trx Code:	TAP5	Labor Hrs:	0	Labor Cost:	0	Material Cost:	0	Total Cost:	25										
Dir Cd-Sub Cd:	01170-*	Name:	DISCOVERY FORD LINCOLN	Ph:	509-7654551	St:	WA	Ctry Cd:	USA	Reg Cd:	NA	Repr Date:	07-AUG-08	DIST(Mile):	25389								
Tech Comments:	ONE DAY OF TAPS PROVIDED																						
IFTWW31RX8E[REDACTED]	F7	T/F7	F	T/BC	T/CD	T/E	A1	T/BE	T/QL	18-05-07	18-08-07	156078	USA	26	1F01 *	* *	F09	SXX	V00 *	*			
AWS Claim Key:	<u>4438463</u>	Doc #:	16276702	Trx Code:	08B06	Labor Hrs:	.3	Labor Cost:	24.87	Material Cost:	7.34	Total Cost:	32.21										
Dir Cd-Sub Cd:	01170-*	Name:	DISCOVERY FORD LINCOLN	Ph:	509-7654551	St:	WA	Ctry Cd:	USA	Reg Cd:	NA	Repr Date:	18-SEP-09	DIST(Mile):	28235								

Tech Comments: INSPECTED & INSTALLED COOLING SYSTEM TEE AS PER RECALL OK

IFTWW31RX8E [REDACTED] F7 T/F7 F T/BC T/CD T/E A1 T/BE T/QL 18-05-07 18-08-07 156078 USA 26 6E01 * * * F09 SXX V00 * *
AWS Claim Key: 4438464 **Doc #:** 16276703 **Trx Code:** 08C01 **Labor Hrs:** .3 **Labor Cost:** 24.87 **Material Cost:** 11.9 **Total Cost:** 36.77
Dlr Cd-Sub Cd: 01170-* **Name:** DISCOVERY FORD LINCOLN **Ph:** 509-7654551 **St:** WA **Ctry Cd:** USA **Reg Cd:** NA **Repr Date:** 18-SEP-09 **DIST(Mile):**28235
Tech Comments: INSPECTED FRONT DRIVER'S SEAT BACK & INSTALLED CLAMP KIT AS PER RECALL OK.

IFTWW31RX8E [REDACTED] F7 T/F7 F T/BC T/CD T/E A1 T/BE T/QL 18-05-07 18-08-07 156078 USA 26 2G01 * * * F09 SXX V00 * *
AWS Claim Key: 4438464 **Doc #:** 16276701 **Trx Code:** 08B07 **Labor Hrs:** .5 **Labor Cost:** 41.45 **Material Cost:** 0 **Total Cost:** 41.45
Dlr Cd-Sub Cd: 01170-* **Name:** DISCOVERY FORD LINCOLN **Ph:** 509-7654551 **St:** WA **Ctry Cd:** USA **Reg Cd:** NA **Repr Date:** 18-SEP-09 **DIST(Mile):**28235
Tech Comments: REPROGRAMMED PCM/IC AS PER RECALL OK.

IFTWW31RX8E [REDACTED] F7 T/F7 F T/BC T/CD T/E A1 T/BE T/QL 18-05-07 18-08-07 156078 USA 28 5001 7C3Z 3504 B F05 S10 V89 H26 42
AWS Claim Key: 4830112 **Doc #:** 16437701 **Trx Code:** E84 **Labor Hrs:** 1.9 **Labor Cost:** 181.51 **Material Cost:** 770.81 **Total Cost:** 952.32
Dlr Cd-Sub Cd: 01170-* **Name:** DISCOVERY FORD LINCOLN **Ph:** 509-7654551 **St:** WA **Ctry Cd:** USA **Reg Cd:** NA **Repr Date:** 11-NOV-09 **DIST(Mile):**29274
Cust Comments: CUSTOMER STATES STEERING WHEEL IS OFF CENTER,PULL RIGHT
Tech Comments: TEST DROVE. VERIFIED CONCERN. NO TSB'S OR SSM'S. VEHICLE PULLS RIGHT AND STEERING VERY LOOSE FEELING. DIAG SLOP IN STEERING GEAR AND DRAG LINK WORN. REPLACED STEERING GEAR AND DRAG LINK. SUBLET FOR ALIGNMENT. TEST DROVE VERIFIED REPAIR. MILES OUT 29287. VEHICLE IS TOO LARGE FOR OUR ALIGNMENT RACK AND THUS HAD TO BE SUBLET TO BEE LINE FRAME & AXLE FOR ALIGNMENT CHECK & ADJUSTMENT.

IFTWW31RX8E [REDACTED] F7 T/F7 F T/BC T/CD T/E A1 T/BE T/QL 18-05-07 18-08-07 156078 USA 50 * * * * F09 SXX V00 * *
AWS Claim Key: 7970771 **Doc #:** 18510301 **Trx Code:** 11B23 **Labor Hrs:** .5 **Labor Cost:** 43.98 **Material Cost:** 0 **Total Cost:** 43.98
Dlr Cd-Sub Cd: 01170-* **Name:** DISCOVERY FORD LINCOLN **Ph:** 509-7654551 **St:** WA **Ctry Cd:** USA **Reg Cd:** NA **Repr Date:** 01-SEP-11 **DIST(Mile):**37027
Tech Comments: REPROGRAMMED PCM/TCM/IC AS PER RECALL OK.

Any comments? You can contact



webmaster

CQIS Report Number: 8JABE337 Program Type: C1
Report Source: MSS - FCSD - CUST ASST CTR

Orig Rpt #: 00005463894M
Report Date: 10/01/2008

----- R E P O R T S U M M A R Y -----

VEHICLE: 2008 F350 4X4 VIN : 1FTWW31RX8E
Engine : 6.4L OHV DUAL T/C V8 INTNL DSL Odometer: 24,000 MILES
Operating Environ: WCC :
Vehicle Use : Rsp. Act:

SYMPTOM: 6 62 3 00 STOP/STEER/RIDE STEERING / STEERING WHEEL
FEEL/WANDER/PULL UNKNOWN (CODE NOT AVAILABLE)

Additional Symptom:
Other Veh. With Concern: Severity Rating - Customer: Engineering:

Causal Component:
Causal Factor: Feature: Loc:
Causal Condition: Photo: Attchmnts: 0
Component Test Status: ---- Return Loc:
Vehicle Fixed?: Customer satisfied?: Repair Effectiveness (%):

----- C O M M E N T S -----

--TYPE-- COMMENT TEXT
AUDIT SYMPTOM 3 03 2 93 CHANGED TO 6 62 3 00 BY CS012093
OWNREL CUSTOMER SAID: 1. VEH WANDERS ALL OVER THE ROAD-HAS HAD MULTIPLE CONCERNS WITH VEH-RADIATOR HAS GONE OUT TWICE PREVIOUSLY AND WAS COVERED UNDER WARRANTY-STEERING BOX GONE OUT AND DLR SAYS THE VEH WARRANTY IS VOIDED BECAUSE THERE ARE LIFTS ON THE VEH-DLR THAT SOLD THE VEH TO CUST VOIDED THE WARRANTY BEFORE CUST BOUGHT THE VEH BECAUSE THEY SOLD IT TO HIM WITH AFTERMARKET PARTS ON IT-PURCHASED THE VEH IN IDAHO FALLS FROM BROADWAY FORD-VEH IS AT HOME BECAUSE HE DOES NOT WANT TO BE CHARGED STORAGE FEES-IDAHO FALLS IS TELLING CUST THAT IT IS NOT THEIR PROBLEM-WOULD NEVER HAD BOUGHT THE VEH IF HE KNEW THAT THE LIFT KIT VOIDED THE WARRANTY-WANTS FORD TO BUY BACK THE VEH-DEALER SAID: -DLR THAT SOLD THE VEH TO CUST VOIDED THE WARRANTY BEFORE CUST BOUGHT THE VEH BECAUSE THEY SOLD IT TO HIM WITH AFTERMARKET PARTS ON IT- DISCOVERY FORD 1140 S. PIONEER WAY MOSES LAKE, WA 98837 TEL: (509) 765-4551 S/M LEO-IDAHO FALLS DLR IS TELLING CUST THAT IT IS NOT THEIR PROBLEM-CCRC ADVISED: I WILL ESCALATE THIS TO OUR CUSTOMER CARE SOLUTIONS TEAM. A SPECIALIST WILL CONTACT YOU WITHIN 2 BUSINESS DAYS. CUST CONTACT NUMBER: [REDACTED]
OWNREL CCS MELISSA, X 7424 ***CASE REVIEW*** NO ESP ON FILE/OPEN SAFETY COMPLIANCE RECALL 08C01 (FRONT DRIVER'S SEAT BACK INSPECTION AND REPAIR) - ONLY VEH ON FILE, RETAIL SALE AND ORIGINALLY OWNED - UNABLE TO REVIEW ANY REPAIR HISTORY IN AWS - PER OASIS, 2/8/08 AT 15,346 MI AND 10/26/07 AT 9,545 MI (RADIATOR REPLACEMENT) - OBC TO DLR AT 509-765-4551 - VEH NOT IN SHOP, CUST PICKED UP - CONCERN WITH VEH ATTRIBUTED TO AFTERMARKET LIFT KIT
OWNREL CCS MELISSA, X 7424 - VEH PURCHASED FROM BROADWAY FORD, 208-525-8500 +++ OBC TO CUST AT [REDACTED] - ADVISED CUST I AM CALLING REGARDING HIS REQUEST FOR A BUYBACK - ADVISED CUST OF MY CONVERSATION WITH SRV REP - CUST CONFIRMED HE PICKED VEH UP - STATES WHEN HE PURCHASED VEH FROM BROADWAY FORD, HE WAS ADVISED IT WAS FULLY-WARRANTIED - I ASKED CUST IF HE WAS PROVIDED DOCUMENTATION SUPPORTING THAT AND HE SAID THEY DIDN'T, THAT HE WAS UNDER ASSUMPTION FULLY WARRANTIED - STATES HE NO LONGER WANTS VEH - STATES HE PURCHASED VEH FROM DLR LIKE THIS - ADVISED CUST WE WILL NOT BE ABLE TO BUYBACK HIS VEH - ADVISED CUST

CQIS Report Number: 8JABE337 Program Type: C1
Report Source: MSS - FCSD - CUST ASST CTR

Orig Rpt #: 00005463894M
Report Date: 10/01/2008

----- C O M M E N T S -----

--TYPE-- ----- COMMENT TEXT -----
AFTERMARKET COMPONENTS DO NOT VOID WARR - ADVISED IF AFTERMARKET

AFTERMARKET COMPONENTS DO NOT VOID WARR - ADVISED IF AFTERMARKET COMPONENTS ARE THE CAUSE OF FAILURE OR DAMAGE TO A CERTAIN COMPONENT, THEN BTB WARR WIL NOT COVER IT - ADVISED CUST HE NEEDS TO TAKE THIS UP WITH SELLING DLR - CUST ADVISED HE TRIED AND THEY STATED IT WAS NOT THEIR PROBLEM AND THAT THEY'RE NOT DOING ANYTHING ABOUT IT - PROVIDED CUST MY CONTACT INFO AND CASE NUMBER - ADVISED CUST TO CONTACT ME IF HE HAS ANY QUESTIONS - CUST ADVISED HE WILL BE CONTACTING AN ATTY - NO FURTHER ACTION REQUIRED

----- C O N C E R N D E T A I L S -----

----- D I A G N O S T I C I N F O R M A T I O N -----

Symp. Verif?: Ease of Diagnosis: Level of Assistance:
Comp. Timing: Base Timing : MIL light on? :
Test Stand : Road Test : 8D Number:
Prior Repair Attempts: Repair Prior to Call: NO

KOEO:
KOEO:
KOEC:
KOEC:
KOER:
KOER:
CB:
CB:

Equipment/Procedure Used Effective? Equipment/Procedure Used Effective

----- S E R V I C E A C T I O N S -----

NO SERVICE ACTIONS AVAILABLE FOR THIS VEHICLE

----- V E H I C L E D E T A I L S -----

Vehicle Build Date: 05/18/2007 Warranty Start Date: 08/18/2007
Date of Sale: 08/18/2007 Selling Dlr(Geo/Mkt,Dlr,Sub):
Dealer Special Order: Gross Vehicle Weight: 1150 LBS
LH/RH Drive:

- - - E N G I N E - - -
Engine: 6.4L OHV DUAL T/C V8 INTNL DSL Tag: 8G 042 AB
Bld Dt: Calb: 8F716A0 A
Serial #: 001077000064

- - - T R A N S M I S S I O N - - -
Trans: 5R110W 5SP-A HI/TORQ Part #:
Bld Dt:
Serial #:

Model: Shft:

CQIS Report Number: 8JABE337 Program Type: C1
Report Source: MSS - FCSD - CUST ASST CTR

Orig Rpt #: 00005463894M
Report Date: 10/01/2008

- - - A D D I T I O N A L - - -

Tire : LT 275/70R18E A/T BSW Brand :
Radio : AM/FM STRO/CD CHANGER/CLK A/C : AC K-????????????????????
Paint : PN3-????????????????????----- DARK BLUE PEARL W/B

----- A F T E R M A R K E T M O D I F I C A T I O N S -----

NO AFTER MARKET MODIFICATIONS DATA AVAILABLE FOR THIS VEHICLE

----- REPORT ORIGINATOR - REPAIR FACILITY - CUSTOMER INFORMATION -----

Rpr Dlr:USA 01170 - Discovery Ford Lincoln Ph#: [REDACTED]
City: Moses Lake State : Washington
Country: United States Region : Seattle

Customer name : [REDACTED] City :

----- C Q I S V I N H I S T O R Y -----

NO CQIS VIN HISTORY AVAILABLE FOR THIS VEHICLE

--- S U P P L E M E N T A L S U R V E Y: MORS III GENERIC BATCH LOAD ---

SURVEY HAS BEEN RECEIVED

----- VEHICLE'S WARRANTY HISTORY (365 days only) -----

Dealer ID	Repair Date	Repair Order	Odometer (Miles)	Rp Nr	Caus Cond	Service Pfx	Part Base	Number Sfx	Labor Operation
USA 01170	09/01/11	185103	37027	1					11B23B



Case Print Report

Case Number [REDACTED]

Case Opened Date 5/15/2013 1:43 PM

Case Closed Date 5/15/2013

Case Status Resolved

Case Last Modified 5/15/2013 1:44 PM

Responsible Team Tier 1 Inbound

Case Classification Vehicle Concern > Legal > Alleged Accident > Not Portal

FORD MOTOR COMPANY
RECEIVED
CLAIMS UNIT

MAY 16 2013

OFFICE OF THE,
GENERAL COUNSEL

Customer Name [REDACTED]

Customer Number [REDACTED]

HUMBLE [REDACTED]

Email [REDACTED]

Dealer [REDACTED]

VIN 1FTSW21R78E [REDACTED]

Year 2008

Make FORD

Model F-SERIES SUPER
DUTY

Body Style W21 - F250 4X4 CREWCAB - SRW

Symptom

Level 1

Level 2

Level 3

Level 4

Case Print Report

Case Number

[REDACTED]

Agent Name	Note Last Modified
Kathy Aldridge	5/15/2013 1:44 PM

Case Print Report

Case Number C [REDACTED]

Agent Name

Note Last Modified

1FTSW21R78E [REDACTED]
CUST SAY:

-STEERING GEAR BOX WENT OUT WHILE CUST WAS DRIVING
-THE TIRES BUMPER AND FENDERS ARE MESSSED UP

Accidents

1. Were any injuries sustained? YES

- Please provide the first and last name of all injured parties [REDACTED]

2. What are you seeking from Ford Motor Company? REPAIR COSTS FOR THE VEHICLE

3. What was the date of the accident? MARCH 10TH 2013

4. What product defect is alleged to have caused the accident? STEERING GEAR BOX

5. What is the City and State where the accident occurred? HOUSTON, TX

6. Was a police report filed? NO

7. If a police report was filed, what were the findings? N/A

8. What is the police report number and in what city and county was the report filed? N/A

9. Has the customer filed a claim with their Insurance Company? (Yes or No) YES

10. If a claim has been filed with the insurance company, what is the status of the claim? PENDING

11. Is the vehicle repairable? YES

12. What is the name and address of customer's attorney? (only if the customer mentions they have sought one) N/A

13. What mailing address would you like our Office of General Council to send your written response to? (You must document the full address in the case Notes)

[REDACTED]
[REDACTED]
[REDACTED]
[REDACTED]
HUMBLE, TX [REDACTED]
[REDACTED]

CRC ADVISED:

I will forward your information to Ford's Office of the General Counsel. You should receive a written response within 15 Days business days to your concern.

Case Print Report

Case Number



Server: AWS Prod
 Claims loaded through: 21-MAY-2013

STANDARD CLAIMS LIST

AWS Online Report

Run Date: 22-MAY-13

Note: All Costs are in US Dollars Server Name: AWS Prod Claims loaded through

VIN	AWS VL	WERS VL	MKT DER	BODY CAB	VER SERIES	DRIVE TYPE	PLANT CD	TRANS CD	ENG COD	PROD DATE	WARR DATE	SELLING DEALER	SELL CNT	TIS	WCC	PREF	BASE	SUFF	VRT NA	VRT ROW	VFG	CCC	CD
1FTSW21R78[REDACTED]	7	T/F7	F	T/BC	T/BD	T/E	A1	T/BE	T/QL	17-MAY-2007	09-NOV-2007	152037	USA	0	7S12	*	14A005	*	F03	S09	V17	S39	X2
AWS Claim Key:		<u>220127</u>	Doc #: 07970451		Trx Code:		1	Labor Hrs:		9	Labor Cost:		72.84	Material Cost:		0	Total Cost:		72.84				
Dir Cd-Sub Cd:		03759-*	Name: FREEWAY FORD				Ph:	281-5885000	St:	TX	Ctry Cd:	USA	Reg Cd:	NA	Repr Date: 08-NOV-2007		DIST(Mile): 25						
Cust Comments:		AIR BAG LIGHT ON																					
Tech Comments:		AIR BAG SYS DIAG B2691 PINPOINT LOCATE AND REPAIR OPEN IN CIRCUIT CLR CODES RETESTCIRCUIT CR201 AT C3065 PIN 1 BU OG WIRE14A005 HARNESS																					
1FTSW21R78[REDACTED]	F7	T/F7	F	T/BC	T/BD	T/E	A1	T/BE	T/QL	17-MAY-2007	09-NOV-2007	152037	USA	13	5G02	*	3078	*	F05	S05	V39	N51	33
AWS Claim Key:		<u>2237544</u>	Doc #: 09558253		Trx Code:		E84	Labor Hrs:		8	Labor Cost:		67.66	Material Cost:		0	Total Cost:		67.66				
Dir Cd-Sub Cd:		03759-*	Name: FREEWAY FORD				Ph:	281-5885000	St:	TX	Ctry Cd:	USA	Reg Cd:	NA	Repr Date: 17-NOV-2008		DIST(Mile): 8223						
Cust Comments:		CUSTOMER STATES HEARS POPPING NOISE WHEN TURNING HARD																					
Tech Comments:		ROAD TEST, CHECK AND TIGHTEN ALL FRT SUSPENSION BOLTS TO CORRECT NOISE WHILE TUNING OVER BUMPS																					
1FTSW21R78[REDACTED]	F7	T/F7	F	T/BC	T/BD	T/E	A1	T/BE	T/QL	17-MAY-2007	09-NOV-2007	152037	USA	13	1A03	8C3Z	6009	A	F04	S11	V29	E29	01
AWS Claim Key:		<u>2286198</u>	Doc #: 09558252		Trx Code:		E84	Labor Hrs:		41.1	Labor Cost:		3475.86	Material Cost:		6234.38	Total Cost:		10470.24				
Dir Cd-Sub Cd:		03759-*	Name: FREEWAY FORD				Ph:	281-5885000	St:	TX	Ctry Cd:	USA	Reg Cd:	NA	Repr Date: 17-NOV-2008		DIST(Mile): 8223						
Cust Comments:		CUSTOMER STATES VEHICLES CHECK ENGINE LIGHT ON, LEAKING OIL, RUNNING ROUGH AND BLOWING BLACK SMOKE																					
Tech Comments:		VERIFY CONCERNS.ENGINE RUNNING ROUGH,LIGHT ON,AND LEAKING OIL VISUAL INSPECTION FOUND OIL IN EXHAUST SYS.OIL LEAK DIAGNOSIS FOUND PASS GLOW PLUG HARNESSPASS SIDE DETACHED.RETRIEVE DTCS P0266,0302,0673,2291 DIESEL ENGINE PERFORMANCE DIAGNOSIS FOUND MISFIRE CYLINDER 2.RELATIVE COMPRESSION LOW CYLINDER 2 MANUAL COMPRESSION TEST FOUND CYL 2, 0 PSI,410 415 REMAINING CYLINDERS.NECESSARY TO TEARDOWN ENG																					

IFTSW21R78 [REDACTED] F7 T/F7 F T/BC T/BD T/E A1 T/BE T/QL MAY-2007 NOV-2007 152037 USA 13 1F01 * * * F09 SXX V00 * *

AWS Claim Key: 2237543 **Doc #:** 09558242 **Trx Code:** 08B06 **Labor Hrs:** 3 **Labor Cost:** 25.37 **Material Cost:** 3.92 **Total Cost:** 29.29

Dir Cd-Sub Cd: 03759-* **Name:** FREEWAY FORD **Ph:** 281-5885000 **St:** TX **Ctry Cd:** USA **Reg Cd:** NA **Repr Date:** 17-NOV-2008 **DIST(Mile):** 8223

Cust Comments: PROGRAM 08B06: DIESEL ENGINE COOLING SYSTEM

Tech Comments: INSTALL A VENTURI KIT INTO THE DEGAS BOTTLE AND RADIATOR VENT HOSES PER PROGRAM

IFTSW21R78 [REDACTED] F7 T/F7 F T/BC T/BD T/E A1 T/BE T/QL MAY-2007 NOV-2007 152037 USA 14 2E03 8C3Z 9A543 B F04 S11 V52 D42 42

AWS Claim Key: 2335109 **Doc #:** 09641251 **Trx Code:** S07 **Labor Hrs:** 14.1 **Labor Cost:** 1192.44 **Material Cost:** 1169.82 **Total Cost:** 2362.26

Dir Cd-Sub Cd: 03759-* **Name:** FREEWAY FORD **Ph:** 281-5885000 **St:** TX **Ctry Cd:** USA **Reg Cd:** NA **Repr Date:** 08-DEC-2008 **DIST(Mile):** 8343

Cust Comments: CUSTOMER STATES STALLED WHILE DRIVING

Tech Comments: VERIFY CONCERN ENG DIES WHILE DRIVING, RESTART COLD SOAK, RETREIVE DTC P0090, PPT INCONCLUSIVE, LOW PRESS FUEL TEST PASS, HIGH PRESS FUEL TEST PASS, DATE MONITOR FOUND FRP DROP TO 3400 PSI UNDER LOAD (15000 DESIRED) CONTACT HOTLINE, PERF HIGH PRESS FUEL PUMP HARNESS SHORT TO FROUND TEST, PASS, REPL HIGH PRESS FUEL PUMP AS PER HOTLINE RECOMMENDATION, REASSEMBLE RETEST, ALL OK AT THIS TIME.

IFTSW21R78 [REDACTED] F7 T/F7 F T/BC T/BD T/E A1 T/BE T/QL MAY-2007 NOV-2007 152037 USA 14 2E03 8C3Z 9A543 B F04 S11 V52 D21 42

AWS Claim Key: 2509400 **Doc #:** 09692551 **Trx Code:** E91 **Labor Hrs:** 15.3 **Labor Cost:** 1293.92 **Material Cost:** 1277.43 **Total Cost:** 2666.35

Dir Cd-Sub Cd: 03759-* **Name:** FREEWAY FORD **Ph:** 281-5885000 **St:** TX **Ctry Cd:** USA **Reg Cd:** NA **Repr Date:** 20-DEC-2008 **DIST(Mile):** 8510

Cust Comments: CUSTOMER STATES VEHICLE DIED WHILE DRIVING

Tech Comments: VERIFY CONCERN, ENGINE STALLING, NO START HOT, RETREIVE DTC P0090, OOT ME PASS HIGH PRESSURE FUEL PUMP, LIFT PUMP PRESS 6 PSI, FUEL QUALITY OK, FP FAULT PID YES DURING CONCERN, CONTACT HOTLINE, OHM RESISTANCE TEST AS PER HOTLINE PASS, SPEC 1.5 150 HM CONCERN PRESENT, PIN 1 TO 3 HIGHT PRESSURE PUMP 6.50 HM CONCERN PRESENT, NO CONCERN, READING 19.3 OHM TO PUMP, INSTRUCTED TO REPLACE PUMP AS PER HOTLI

IFTSW21R78 [REDACTED] F7 T/F7 F T/BC T/BD T/E A1 T/BE T/QL MAY-2007 NOV-2007 152037 USA 16 1F01 8C3Z 8009 B F04 S11 V45 E23 D1

AWS Claim Key: 2987762 **Doc #:** 09946251 **Trx Code:** E84 **Labor Hrs:** 2.7 **Labor Cost:** 228.34 **Material Cost:** 565.24 **Total Cost:** 793.58

Dir Cd-Sub Cd: 03759-* **Name:** FREEWAY FORD **Ph:** 281-5885000 **St:** TX **Ctry Cd:** USA **Reg Cd:** NA **Repr Date:** 26-FEB-2009 **DIST(Mile):** 9578

Cust Comments: CUST STATES VEHICLE IS LEAKING COOLANT OVER HEATING

Tech Comments: VERIFY CONCERN, ENGINE LEAKING COOLANT, COOL SYS PRESS TEST FAIL RADIATOR, INSTALL NEW RETEST, ALL OK AT THIS TIME, OIL COOLANT DYE

IFTSW21R78 [REDACTED] F7 T/F7 F T/BC T/BD T/E A1 T/BE T/QL MAY-2007 NOV-2007 152037 USA 16 2E02 * * * F09 SXX V00 * *

AWS Claim Key: 2975660 **Doc #:** 09946241 **Trx Code:** 08C04 **Labor Hrs:** 9 **Labor Cost:** 76.11 **Material Cost:** 30.72 **Total Cost:** 109.83

Dir Cd-Sub Cd: 03759-* **Name:** FREEWAY FORD **Ph:** 281-5885000 **St:** TX **Ctry Cd:** USA **Reg Cd:** NA **Repr Date:** 26-FEB-2009 **DIST(Mile):** 9578

Cust Comments: 08C04 DEMONSTRATION DELIVERY HOLD FUEL TANK STOPPER BRACKET INSTALLAT

Tech Comments: INSTALL FUEL TANK STOPPER BRACKET

IFTSW21R78F [REDACTED] F7 T/F7 F T/BC T/BD T/E A1 T/BE T/QL 17- MAY- 2007 09- NOV- 2007 152037 USA 16 2G01 * * * F09 SXX V00 * *

AWS Claim Key: 2975670 **Doc #:** 09946242 **Trx Code:** 08B07 **Labor Hrs:** .5 **Labor Cost:** 42.29 **Material Cost:** 0 **Total Cost:** 42.29

Dir Cd-Sub Cd: 03759-* **Name:** FREEWAY FORD **Ph:** 281-5885000 **St:** TX **Ctry Cd:** USA **Reg Cd:** NA **Repr Date:**26-FEB-2009 **DIST(Mile):**9578

Cust Comments: 08B07 CERTAIN 2008 MODEL YEAR F SUPER DUTY VEHICLES EQUIPPED WITH A 6.4

Tech Comments: REPROGRAM THE PCM, TCM AND IC USING IDS RELEASE 58.4

IFTSW21R78F [REDACTED] F7 T/F7 F T/BC T/BD T/E A1 T/BE T/QL 17- MAY- 2007 09- NOV- 2007 152037 USA 16 6E01 * * * F09 SXX V00 * *

AWS Claim Key: 2975668 **Doc #:** 09946240 **Trx Code:** 08C01 **Labor Hrs:** .3 **Labor Cost:** 25.37 **Material Cost:** 11.9 **Total Cost:** 37.27

Dir Cd-Sub Cd: 03759-* **Name:** FREEWAY FORD **Ph:** 281-5885000 **St:** TX **Ctry Cd:** USA **Reg Cd:** NA **Repr Date:**26-FEB-2009 **DIST(Mile):**9578

Cust Comments: 08C01 DEMONSTRATION DELIVERY HOLD PERFORM PRIOR TO VEHICLE DELIVERY

Tech Comments: INSPECT THE FRONT DRIVER SEAT BACK AND INSTALL CLAMP KIT

IFTSW21R78F [REDACTED] F7 T/F7 F T/BC T/BD T/E A1 T/BE T/QL 17- MAY- 2007 09- NOV- 2007 152037 USA 35 1H03 8C3Z 9D475 D F04 S11 V29 E29 42

AWS Claim Key: 6487155 **Doc #:** 079004A **Trx Code:** S07 **Labor Hrs:** .9 **Labor Cost:** 78.3 **Material Cost:** 196.66 **Total Cost:** 274.96

Dir Cd-Sub Cd: 04528-* **Name:** TOMMIE VAUGHN MOTORS, INC. **Ph:** *-* **St:** TX **Ctry Cd:** USA **Reg Cd:** NA **Repr Date:**02-SEP-2010 **DIST(Mile):**32320

Cust Comments: E29 CUSTOMER STATES ENGINE LIGHT ON & SLOW TO ACCEL AT TIMES

Tech Comments: VERIFIED CUSTOMERS CONCERN AND PERFORMED DIESEL DIAG FOUND OIL AND FUEL OK. PERFRED KOEO AND FOUND DTC P1335.VERIFY NO LATER CALIBRATION AVAILABLE. REFERED TO PIN POINT TEST W AND PERFORMED EGR SYSTEM TEST AND FOUND EGR VALVE TOFAIL AT 3.4 VOLTS. REPLACED EGR VALVE AND ROAD TESTED AND RETESTED FOUND SYSTEM OPERATIN CORRECTLY.

Any comments? You can contact



webmaster



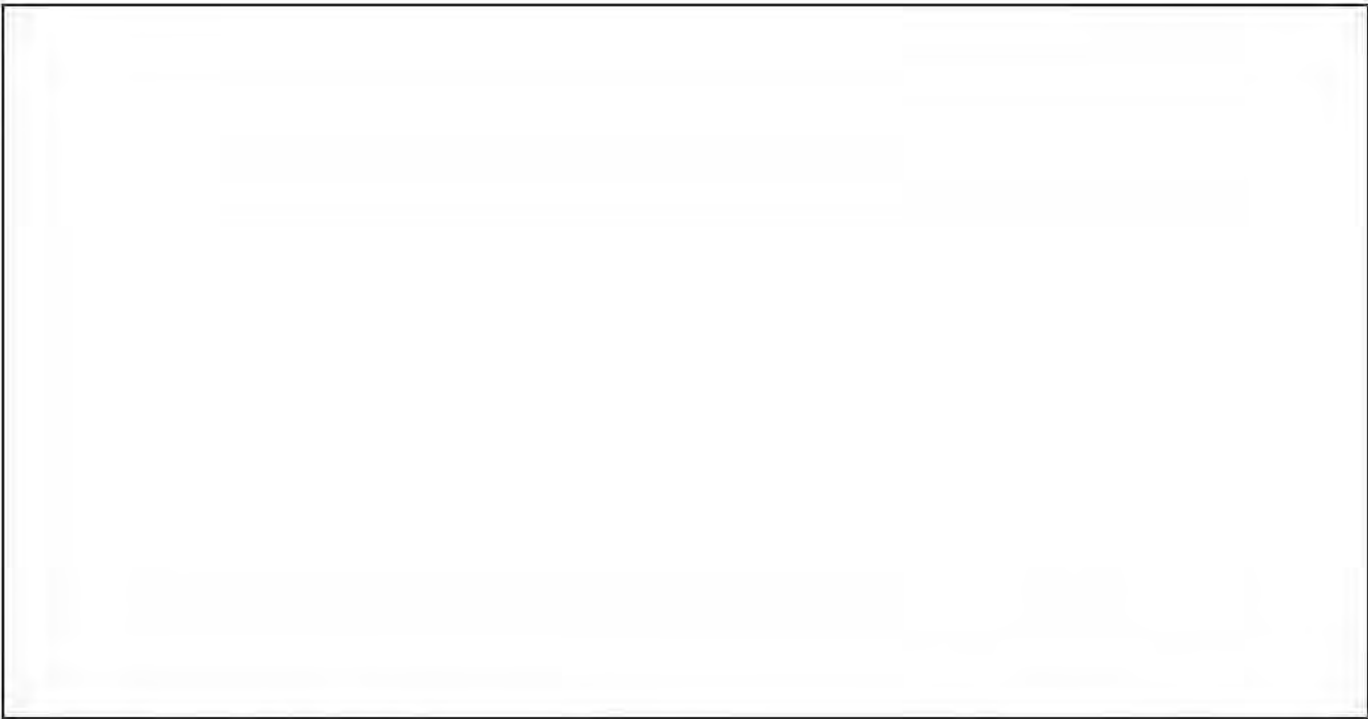

From: dcpform@ford.com [mailto:dcpform@ford.com]
Sent: Friday, August 27, 2010 9:26 AM
To: Ordcalp, F (F.); Taylor, Alma (A.)
Subject: Dealer/Fleet Request For OGC Review

Dealer/Fleet Request For OGC Review

Dealership/Fleet Name: Laramie Peak Motors
Requesting Dealer/Fleet: Laramie Peak Motors
Contact Person: Jim Baugh
Title: Service Manager
Address: 2305 N 16th Street
Telephone: 3073222355
Email Address: jbaugh@laramiepeakmotors.com
PA Code: 00489
Region: Denver-Select
City: Wheatland
Dealer State: WY
Fax Number: 3073225510
WSD: 11/07/2007
Vehicle Year: 2008
Vehicle Model: F350
Vehicle VIN: 1FDWX37YX8E [REDACTED]
Mileage: 48804
Customer/Fleet: [REDACTED]
Street Address: [REDACTED]
City: Douglas
State: Wyoming
Zip Code: [REDACTED]

8/27/2010

Home Phone: [REDACTED]

Work Phone: [REDACTED]

Customer Region: S2 - Charlotte

Incident Involves: Accident

Date of Incident: [REDACTED]

County in which incident occurred: Goshen

Is Alleging Defect: Yes

Alleging defect detail: While driving vehicle lost steering control due to broken steering gear. As a result of the inability to steer vehicle it ran into ditch, bending front bumper & grille guard plus right side running board is broken.

Police Report Filed: No

Insurance Company Contacted: N

Coach Builder State: AK - Alaska

Vehicle Location: Vehicle is at Laramie Peak Motors, 2305 N 16th Street, Wheatland Wyoming

Resolution Sought Detail: Customer wants bumper, grille guard and running board replaced.

Comments: This vehicle is a work vehicle and the customer cannot have the repairs delayed. After service manager advised customer of potential delays to repairs due to OGC involvement, he decided to just replace the steering gear as he need the vehicle returned in running order by Friday 8/27. Customer advised service manager that he would then involve his attorney and let the courts decide who was paying for the consequential damage. The steering gear is covered under his ESP contract. If this is a duplicate entry please disregard.

This email was automatically generated. Please do not reply to this email. No one monitors the inbox for this email address.

8/27/2010



Premier Legal Center, A.P.C.

2550 5th avenue, 9th Floor
San Diego, California 92013
Toll Free: (877) 441-4441
Fax: (619) 235-3300



April 1, 2011



Ford Motor Company
Office of the General Counsel
One American Road
Dearborn, MI 48126

Re: [REDACTED] v. Ford Motor Company
2008 Ford F-350
VIN: 1FTWX32R08[REDACTED] the "Vehicle")

LITIGATION
PRACTICE GROUP

11 APR 11 P2:18

OFFICE OF THE
GENERAL COUNSEL

Ford Motor Company :

My firm has been retained to represent [REDACTED] with respect to a claim against you. Please direct all communications concerning this matter to me.

In January 2009 my client purchased the above referenced Vehicle used (only 4,000 miles) from Mark Martin Ford Mercury in Batesville, Arkansas for approximately \$28,000. The product did not conform to the warranties and representations made by Ford and its dealers and the applicable warranties have been breached.

The Vehicle has experienced major problems with coolant loss, steering, suspension, and other issues. The Vehicle been repaired at least 4 times plus routine services (over 25 days in the shop), and still has defects. The Vehicle's repair history is supported by the attached invoice detail reflecting significant engine and other operational repairs. These repairs cost my client over \$3,000 in direct out of pocket costs.

A summary of these repairs follows:

Date	Days	Problem and Repair
5/4/10	18	coolant loss, replace radiator
7/12/10	3	suspension, replace ball joint assemblies
3/1/11	7	steering, replace steering gear and power steering pump assembly

It is my contention that Ford failed to tender the Vehicle free of defects and its failure to repair the defective Vehicle constitutes a breach of the written and implied warranties covering the Vehicle and is a violation of the MMWA to which Plaintiff is entitled to recover: (1) his damages under 15 U.S.C. §2310(d)(1) or (2) a full refund under 15, U.S.C. §2304(a)(4). My client has performed all things agreed and required of him under the purchase agreement and warranty, except as may have been excused or prevented by the conduct of Ford.

In addition to the protection federal law affords them, my client contends that Ford also violated the State Lemon Laws.

As a direct and proximate result of Ford's violation of its obligations under federal and state law, my client has suffered the following damages:

- A. Cost of repair;
- B. Diminished value of the Vehicle;
- C. Out of pocket expenses;
- D. Loss of use and income; and
- E. Attorney's Fees

Based on the foregoing, my client demands that Ford rescind the transaction by which my client purchased the Vehicle. Upon your agreement to cancel the transaction, my client will return the Vehicle to you in exchange for a full refund of the money paid for this Vehicle, less a reasonable charge for his use of the Vehicle. Alternatively, my client will accept a \$30,000 cash settlement in full and final satisfaction of this claim.

My client has also incurred reasonable and necessary attorney's fees in the pursuit of this claim stated in this letter. The amount of fees and costs incurred as of the date of this letter is \$4,000.00, paid in addition to any cash settlement or repurchase, for total of \$34,000.00.

Under the contract of employment I have with our client, my firm has been assigned an interest in the claim against you.

OFFER OF SETTLEMENT

The purpose of this letter is to encourage you to resolve my client's claim in a fair and equitable manner without the need of further legal action. In the event you fail to take advantage of this offer of settlement, I will have no alternative but to recommend to my client that a lawsuit be filed against you under the Magnuson-Moss-Warranty Act and the DTPA. In this lawsuit, rather than seeking only the amount of compensation I am asking of you at this time, I will seek to recover the full measure of damages to which our client is legally entitled as well as our client's expenses and attorney's fees as allowed by law.

If you are interested in resolving this matter without the necessity of litigation, please contact me with sufficient time to resolve the dispute within thirty (30) days of your receipt of this letter. Thank you for your attention to this letter.

Very truly yours,

Steven L. Marchbanks

Doenges

TOYOTA · FORD · LINCOLN · MERCURY
 1901 SE Washington Blvd.
 Bartlesville, OK 74006
 Telephone: (918) 333-0900

SERVICE DEPARTMENT HOURS
 7:00 a.m. to 6:00 p.m.
 Monday - Friday
 8:00 a.m. - 1:00 p.m. - Saturday

RO Open Date	RO Number
7/12/10	6184236/1
RO Close Date	State
7/14/10	Reprint
Invoice #	Invoice Out
43316	43316
Service Advisor Name	
Bruce Doenges/4495	
Technician License Number	
1FTWX32R08E	
Delivery Date	
Color	License Number

MARSHALL, AR		2WD SUPERCAB 158"	
Year	Make	Model	
2008	FORD	SUPER DUTY F-	2WD SUPERCAB 158"

DESCRIPTION OF REPAIR AND PARTS	AMOUNT
#1 - BS 08FO: BRAKE CONCERN CUSTOMER STATES THAT WHEN APPLYING THE BRAKES AT LOW SPEEDS THE BRAKES FEEL FUNNY AND THE STEERING WHEEL IS VERY HARD TO TURN. Work performed by JOHN FRAZEE(679) Sub Total: Labor: 179.90 Parts: .00 Total: 179.90 679 INSPECT P/S NO ASSIST FOUND FLUID OVERFULL AND APPEARS TO HAVE WATER IN FLUID TSB 08-12-10 POSSIBLE CONTAMINATION FROM WASHER FLUID ADDED TO WRONG RESERVOIR RECOMMEND FLUSH AND RETEST POWER STEERING FLUSH P/S FLUID REPEAT 4 TIMES TEST DRIVE OPERATION OK AT THIS TIME M/I 43316 M/O 43330	179.90
#2 - BS 00FOFOB: PROGRAM KEY/REMOTE CUSTOMER WOULD LOIKE HIS KEY PAD CODE PULLED Work performed by JOHN FRAZEE(679) Sub Total: Labor: 50.00 Parts: .00 Total: 50.00 679 CONNECT IDS RETRIEVE DOOR CODE 33717	50.00
#3 - BS Q99P: INSPECTION REPORT THAT WAS PERFORMED ON YOUR VEHICLE AT NO CHARGE TO YOU Sub Total: Labor: .00 Parts: .00 Total: .00 PERFORMED	
#4 * BS 00FOBGPSFL: BG PS FLUSH - REMOVE WORN-OUT, CONTAMINATED FLUID AND INSTALL FRESH NEW FLUID. Installed XT5QMB :MERCURON ATF	23@3.89 89.47

TERMS: STRICTLY CASH UNLESS ARRANGEMENTS ARE MADE. *I hereby authorize the repair work hereinafter to be done along with the necessary material and agree that you are not responsible for loss or damage to vehicle or articles left in the vehicle in case of fire, theft, or any other cause beyond your control or for any delays caused by unavailability of parts or delays in parts shipments by the supplier or transporter. I hereby grant you or your employees permission to operate the vehicle herein described on streets, highways, or elsewhere for the purpose of testing and/or inspection. An express mechanic's lien is hereby acknowledged on above vehicle to secure the amount of repairs thereto.

DISCLAIMER OF WARRANTIES. Any warranties on the products sold hereby are those made by the manufacturer. The seller hereby expressly disclaims all warranties either express or implied, including any implied warranty of merchantability or fitness for a particular purpose, and the seller neither assumes nor authorizes any other person to assume for it any liability in connection with the sale of said products. Any limitation contained herein does not apply where prohibited by law.

LABOR	
PARTS	
DEDUCTIBLE	
SUBLET	
SHOP SUPPLIES	
HAZARDOUS MATERIALS	
SALES TAX OR TAX I.D.	
SPECIAL ORDER DEPOSIT	
DISCOUNTS	
TOTAL DUE	

NO RETURN ON ELECTRICAL OR SAFETY ITEMS OR SPECIAL ORDERS

X

© 2003 ARVCHA, Inc. - Dealership Association Group 100-946-1028



TOYOTA - FORD - LINCOLN - MERCURY

1901 SE Washington Blvd.
Bartlesville, OK 74006
Telephone: (918) 333-0900

SERVICE DEPARTMENT HOURS
7:00 a.m. to 6:00 p.m.
Monday - Friday
8:00 a.m. - 1:00 p.m. - Saturday

R/O Order Date	R/O Number
3/01/11	6196001/1
R/O Issue Date	3/01/11
3/07/11	Pre-Invoice
58722	58722
Service Advisor: Trent	
Brent Guthrie/2622	

MARSHALL, AR			Vehicle #	1FTWX32R08E
			Home Phone	
Year	Make	Model	Color	License/Title
2008	FORD	SUPER DUTY F-	2WD SUPERCAB 158"	

DESCRIPTION OF SERVICE AND PARTS	AMOUNT
<p>#1 - 04FOSTRNG: STEERING CONCERN CUSTOMER STATES THAT THE POWER STEERING AND POWER BRAKES ARE ACTING UP ALOT OF TIMES THEY HAVE NO POWER ASSIST CHECK/ADVISE Caused by POWER STEERING GEAR,BINDS TURNING LEFT POWER STEERING PUMP,LOW PRESURE Work performed by SCOTT KOCH (107) 314.83 Work performed by SCOTT KOCH (107) 278.85 Installed 7C3Z 3504 BRM :GEAR ASY - STEERING 1@334.29 334.29 Installed 7C3Z 3A674 D :PUMP ASY - POWER STEERING 1@198.19 198.19 Installed XT5QMB :MERCURON ATF 1@3.89 3.89 Installed 388898 S :SEAL 1@2.00 2.00 VERIFIED CONCERN. TESTED POWER STEERING. REPLACED STEERING GEAR. REPLACED FLUID. RETEST. STEERING IS S TILL STIFF BOTH WAYS. REPLACED POWER STEERING PUMP ASSY. ADDED FLUID. RETEST OK QC BY SK Sub Total: 1132.05</p>	
<p>#2 - Q99P: INSPECTION REPORT THAT WAS PERFORMED ON YOURVEHICLE AT NO CHARGE TO YOU INSPECT.ALL TIRES NEED REPLACED Sub Total: .00</p>	
<p>#3 - 46FO3: ACCESSORY CONCERN CUSTOMER STATES THAT ON DASH IT IS DISPLAYING A TRAIL BRAKE CONTROL MODULE ERROR CHECK/ADVISE Caused by BRAKE PRESURE TRANSDUCER</p>	

TERMS: STRICTLY CASH UNLESS ARRANGEMENTS ARE MADE. *I hereby authorize the repair work hereinafter to be done along with the necessary material and agree that you are not responsible for loss or damage to vehicle or articles left in the vehicle in case of fire, theft, or any other cause beyond your control or for any delays caused by unavailability of parts or delays in parts shipments by the supplier or transporter. I hereby grant you or your employees permission to operate the vehicle herein described on streets, highways, or elsewhere for the purpose of testing and/or inspection. An express mechanic's lien is hereby acknowledged on above vehicle to secure the amount of repairs thereto.*

DISCLAIMER OF WARRANTIES. Any warranties on the products sold hereby are those made by the manufacturer. The seller hereby expressly disclaims all warranties either express or implied, including any implied warranty of merchantability or fitness for a particular purpose, and the seller neither assumes nor authorizes any other person to assume for it any liability in connection with the sale of said products. Any limitation contained herein does not apply where prohibited by law.

LABOR	
PARTS	
DEDUCTIBLE	
SUBLET	
SHOP SUPPLIES	
HAZARDOUS MATERIALS	
SALES TAX OR TAX I.D.	
SPECIAL ORDER DEPOSIT	
DISCOUNTS	
TOTAL DUE	

NO RETURN ON ELECTRICAL OR SAFETY ITEMS OR SPECIAL ORDERS

X

© 2008 APG/DA, Inc. Dealership Application Group (B00)045-1028



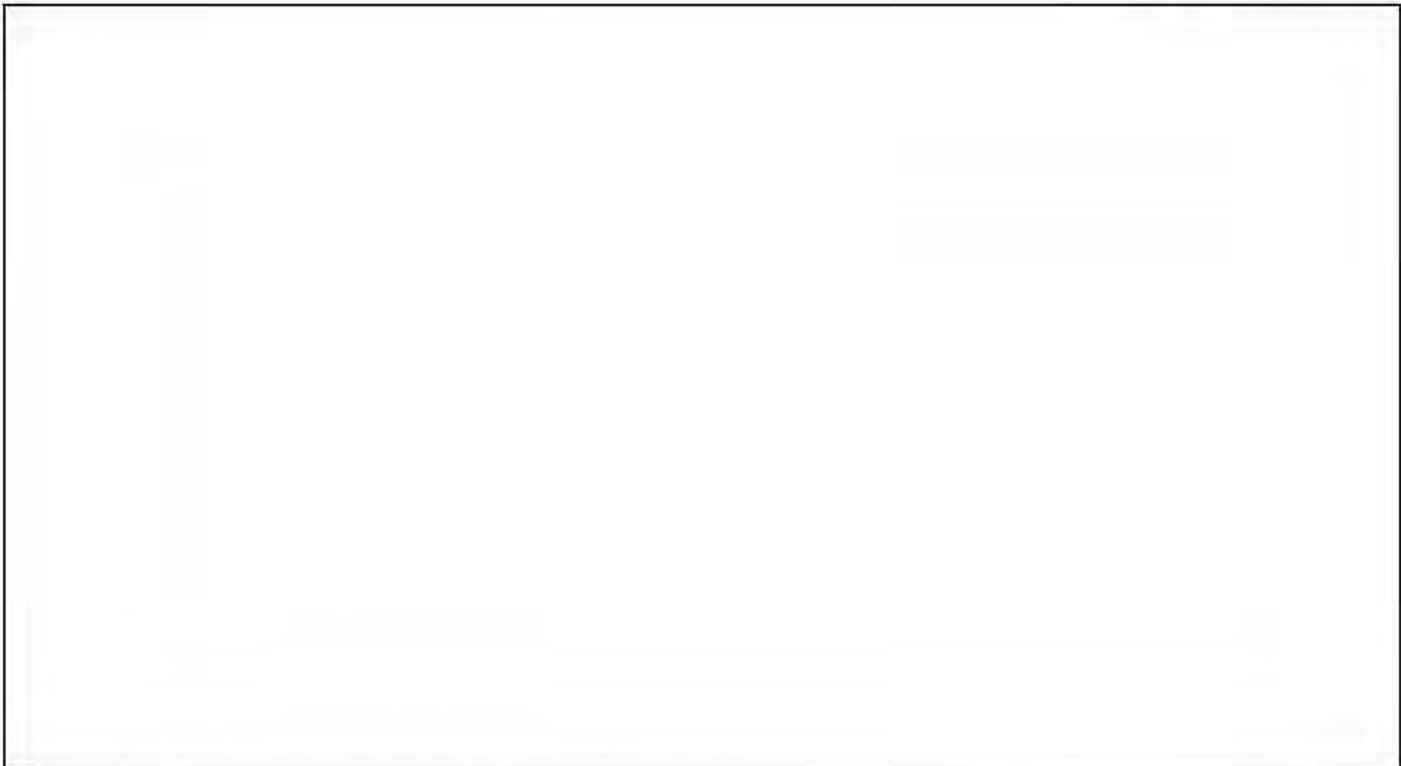

From: dcpform@ford.com [mailto:dcpform@ford.com]
Sent: Monday, February 15, 2010 3:06 PM
To: Ordcalp, F (F.)
Subject: Dealer/Fleet Request For OGC Review

Dealer/Fleet Request For OGC Review

Dealership/Fleet Name: FUTURE FORD
Requesting Dealer/Fleet: FUTURE FORD
Contact Person: JIM VEILLEUX
Title: SERVICE MANAGER
Address: 650 AUTO MALL DR
Telephone: 5306767044
Email Address: JIMV@FUTUREFORD.COM
PA Code: 07749
Region: SF
City: ROSEVILLE
Dealer State: CA
WSD: ?
Vehicle Year: 2008
Vehicle Model: F-250
Vehicle VIN: 1FTSX21R98E [REDACTED]
Mileage: 0
Customer/Fleet: [REDACTED]
Street Address: [REDACTED]
City: MILL VALLEY
State: California
Zip Code: [REDACTED]
Home Phone: [REDACTED]

FOR
15 2010
OF
GENE

2/15/2010

Work Phone: [REDACTED]
Customer Region: W2 - San Francisco
Incident Involves: Accident
Date of Incident: [REDACTED]
County in which incident occurred: ?
Is Alleging Defect: Yes
Alleging defect detail: STEERING GEAR INTERNAL FAILURE.
Police Report Filed: No
Police Report detail: UNSURE
Insurance Company Contacted: Y
Insurance Company Advice: CUSTOMER SAID HE WAS GOING TO CALL AGENT TODAY.
Insurance Company Contact Information: ??
Coach Builder: NA
Coach Builder State: AK - Alaska
Vehicle Location: WHITMANS BODY SHOP 76 Woodland Ave SAN RAFAEL, CA
Resolution Sought Detail: VEHICLE REPAIR

This email was automatically generated. Please do not reply to this email. No one monitors the inbox for this email address.

2/15/2010



1 **THE LAW OFFICES OF ALBERT J. MORRISON**

2 ATTORNEY AT LAW

3 90 S. Kyrene

4 Suite 1

5 Chandler, Arizona 85226

6 Telephone (480) 444-9206

7 Albert J. Morrison (024300)

8 ajm@almorrisonlaw.com

9 Attorney for Plaintiff

COPY



AUG 9 3 2012

MICHAEL H. JEANES, CLERK
A. J. FULTON
DEPUTY CLERK

10 **IN THE SUPERIOR COURT OF THE STATE OF ARIZONA**

11 **IN AND FOR THE COUNTY OF MARICOPA**

12	██████████ an individual,)	CASE NO: ██████████
13)	
14	Plaintiff,)	
15)	COMPLAINT FOR RESTITUTION
16	v.)	DAMAGES and CIVIL PENALTY
17)	
18	FORD MOTOR COMPANY, a)	1. Breach of A.R. S. §44-1261 et seq.
19)	
20	Corporation, and DOES 1 through 10,)	2. Breach of Implied Warranty
21)	
22	inclusive,)	3. Breach of Implied Warranty -
23)	Merchantability
24	Defendants.)	
25)	4. Breach of Express Warranty
26)	

27 1. Plaintiff ██████████ ("Plaintiff") brings this action on their own behalf
28 and based upon information and belief against Defendants FORD MOTOR COMPANY, a
Corporation, and DOES 1 through 10 inclusive ("Defendants").

2. On or about February 9, 2010 Plaintiff purchased a 2008 Ford F-350 Vehicle
Identification Number 1FTWW31R88E ██████████ ("Vehicle" or "FORD").

3. The Vehicle was purchased as a used vehicle, and has had significant
nonconformities during the manufacturers, Defendant FORD's, factory warranty period.

4. Soon after purchasing the Vehicle, Plaintiff experienced continuing
nonconformities with the Vehicle, including but not limited to, the following: major recurring

1 problems with exhaust and emission items, coolant loss, steering gear defects (three repairs), oil
2 leaks, plus other operational issues. After driving the Vehicle for less than 17,000 miles, the
3 Vehicle had an additional major repair due to a blown head gasket. The Vehicle has been in
4 the shop at least 20 times and spent over 100 days in the shop. The Vehicle still has defects.

5 5. Despite confirmation of the nonconformities and repeated lengthy repair
6 attempts, Defendants have been unable to correct the nonconformities. These nonconformities
7 substantially impair the use, value and/or safety of the Vehicle.

8
9 **PARTIES**

10 6. Plaintiff [REDACTED] is an individual residing in the city of Scottsdale, in
11 the County of Maricopa, State of Arizona.

12 7. Defendant FORD MOTOR COMPANY is a corporation registered and
13 transacting business in the County of Maricopa, State of Arizona.

14 8. The true names and capacities of Defendants sued herein under *Arizona Rules of*
15 *Civil Procedure*, Rule 10(f) as DOES 1 through 10, inclusive, are presently unknown to
16 Plaintiffs who will seek to amend this complaint to include these DOE Defendants when they
17 are identified.

18 9. At all times mentioned in the complaint, each of the Defendants was an agent of
19 each and every other Defendant. In doing the things alleged in the complaint, each Defendant
20 was acting within the course and scope of their agency and was acting with the consent,
21 permission and authorization of each of the other Defendants.

22
23 **JURISDICTION AND VENUE**

24 10. This Court has jurisdiction over this action pursuant to the Constitution of the
25 State of Arizona, Article VI, Section 14, as this case is not a cause given by statute to other
26 trial courts.

27 11. This Court has jurisdiction over each Defendant pursuant to A.R.S. §§12-122,
28 12-123 and *Arizona Rules of Civil Procedure*, Rule 4.2(a) Code of Civil Procedure Section

1 410.10 by virtue of their extensive business dealings and transactions within this state. Each
2 Defendant is either a corporation or association organized under the laws of the State of
3 Arizona, a foreign corporation or association authorized to do business in Arizona, or does
4 sufficient business, has sufficient minimum contacts with or avails itself of the Arizona market
5 through the manufacturing, production, promotion, sale, marketing and distribution of product
6 in Arizona. Exercise of jurisdiction by Arizona courts is permissible under traditional notions
7 of fair play and substantial justice.

8 12. Venue is proper in this County pursuant to Title 29 of the United States Code,
9 Chapter 18 Section 1132 and A.R.S. §12-401 as this is a court of competent jurisdiction, and
10 the contract for sale of the subject Vehicle was entered into in this County.

11
12 **FIRST CAUSE OF ACTION**

13 **(Complaint for violation of A.R.S. §44-1261 *et seq.* as against all Defendants)**

14 13. Plaintiff [REDACTED] incorporates all prior allegations.

15 14. The Vehicle is a "used motor vehicle" as defined under A.R.S. §44-1261.

16 15. Plaintiff is a "consumer" as defined under A.R.S. §44-1261.

17 16. Defendant FORD MOTOR COMPANY is the manufacturer of the vehicle
18 purchased by Plaintiff [REDACTED]

19 17. The sale of the Vehicle to Plaintiff was accompanied by an express written
20 warranty.

21 18. The serious nonconformities have manifested themselves within the applicable
22 express warranty period. The nonconformities substantially impair the use, value and/or safety
23 of the Vehicle and or can cause serious bodily injury or death.

24 19. Plaintiff brought the Vehicle to an authorized repair facility for repairs on
25 numerous occasions in attempts to have the existing express warranties satisfied.

26 20. Defendant has not repaired the nonconformities after a reasonable number of
27 attempts and, as such, has failed to comply with and have breached all applicable warranty
28 requirements.

1 21. Further, the sale of the Vehicle to Plaintiff was accompanied by implied
2 warranties that the Vehicle was merchantable and fit for a particular use.

3 22. Defendant has breached the implied warranties of merchantability and fitness for
4 a particular use because the Vehicle when leased would not pass without objection in the trade.

5 23. Despite their breach of the express and implied warranties, Defendants have
6 refused Plaintiffs' demand for a refund or replacement.

7 24. By failure of Defendants to remedy the defects as alleged above, or to issue a
8 refund or replacement, Defendants are in breach of their obligations under A.R.S. §44-1261 *et*
9 *seq.*

10 25. Defendants' continuing breach of their obligations as set forth herein is willful
11 pursuant to the A.R.S. §44-1261 *et seq.* and as such, Defendants and each of them are liable to
12 Plaintiffs for civil penalties in an amount as set forth below.

13
14 **SECOND CAUSE OF ACTION**

15 **(Breach of Implied Warranty)**

16 26. Plaintiff hereby incorporate each and every allegation contained in paragraphs 1
17 through 25 above as though fully set forth herein.

18 27. At all times relevant, Defendants, and each of them, appended to the sale of the
19 Vehicle a written warranty in the form of a written statement pursuant to which it undertook to
20 preserve or maintain the utility or performance of said Vehicle.

21 28. The sale of the Vehicle to the Plaintiff was accompanied separately,
22 individually, and respectively by Defendants, and each of them, with an implied warranty that
23 the Vehicle was merchantable.

24 29. However, Defendants, and each of them, breached their respective warranties as
25 implied in said lease of the Vehicle in that the Vehicle had numerous defects requiring multiple
26 repairs and preventing Plaintiff from using the Vehicle for its intended purpose. As a result
27 thereof, Plaintiffs did not receive merchantable good as impliedly warranted by Defendants,
28 and each of them.

1 30. Plaintiff has expended funds to have the Vehicle repaired and serviced to
2 conform to the Defendants' express warranty and Defendants' failure to repair or service the
3 Vehicle; Plaintiff has incurred repair costs in amounts according to proof at time of trial.

4 31. As a further proximate result of Defendants, and each of them, willful failures to
5 comply with its obligations to Plaintiff, Plaintiff was damaged in that Plaintiff was denied the
6 use of said Vehicle for more than 30 days.

7 32. As a further result of Defendants' failure to comply with their obligations to
8 Plaintiff, Plaintiff has been required to incur attorney's fees herein.

9
10 **THIRD CAUSE OF ACTION**

11 **(Breach of Warranty of Merchantability)**

12 33. Plaintiff hereby incorporates each and every allegation contained in paragraphs
13 1 through 32 above as though fully set forth herein.

14 34. Defendants, and each of them, warranted and represented that said Vehicle was
15 of merchantable quality.

16 35. Said Vehicle was not of merchantable quality in that numerous defects required
17 multiple repairs as set forth herein.

18
19 **FOURTH CAUSE OF ACTION**

20 **(Breach of Express Warranty)**

21 36. Plaintiff hereby incorporates herein each and every allegation contained in
22 paragraphs 1 through 35 above as though fully set forth herein.

23 37. Defendants, and each of them, expressly and by advertising, warranted and
24 represented to the general public and to Plaintiff, and each of them, that the Vehicle was
25 reasonably fit for the purpose for which it was intended.

26 38. Plaintiff relied on said warranties and representations.

27 39. The Vehicle was not fit for the purpose for which it was intended in that
28 Plaintiff discovered multiple defects as identified by dates hereinabove. Plaintiff thereon

1 attempted to act on Defendants' express warranty, as subject to the requirements of A.R.S. §44-
2 1261 *et seq.*, under which Defendants were required to and did maintain local service and
3 repair facilities.

4 40. However, Defendants willfully violated the provisions of the act and breached
5 the express warranty made in the sale to the Plaintiff.

6 41. As a proximate result of the failure of the Vehicle's engine to conform to the
7 Defendants' express warranty, Plaintiff has been damaged in an amount to be proven in Court.

8 42. As a further proximate result of the Defendants' willful failure to comply with
9 its' obligations to Plaintiff, Plaintiff has been required to incur attorney's fees herein.

10
11 **PRAYER FOR RELIEF**

12 WHEREFORE, Plaintiff [REDACTED] prays for judgment as follows:

- 13 1. For general, special and actual damages according to proof at trial;
- 14 2. For rescission of the purchase contract and restitution of all monies expended;
- 15 3. For incidental and consequential damages according to proof at trial;
- 16 4. For a civil penalty in an amount of two times plaintiff's actual damages;
- 17 5. For prejudgment interest at the legal rate;
- 18 6. For reasonable attorney's fees and costs of suit; and
- 19 7. For such other and further relief as this Court deems just and proper.

20
21 RESPECTFULLY SUBMITTED this 3rd day of August, 2012.

22 **THE LAW OFFICES OF ALBERT J. MORRISON**

23
24 

25 By: Albert J. Morrison
26 Attorney For Plaintiff

AZ

PREMIER LEGAL CENTER, A.P.C.

2550 5th Avenue, 9th Floor
San Diego, California 92013
Toll Free: (877) 441-4441
Fax: (619) 235-3300

STEVEN L. MARCHBANKS
steve@premierlegalcen.com
Licensed in CA

May 11, 2012

Ford Motor Company
Office of the General Counsel
One American Road
Dearborn, MI 48126

RECEIVED
MAY 11 2012

Re: [REDACTED], Ford Motor Company
2008 Ford F-350
VIN: 1FTWW31R88E [REDACTED] the "Vehicle")

FORD MOTOR COMPANY
RECEIVED
CLAIMS UNIT

MAY 16 2012

Ford Motor Company:

OFFICE OF THE
GENERAL COUNSEL

My firm has been retained to represent [REDACTED] with respect to a claim against you. Please direct all communications concerning this matter to me.

On February 9, 2010 my client purchased the above referenced Vehicle used from Auto Now in Phoenix, Arizona for approximately \$36,800. The product did not conform to the warranties and representations made by Ford and its dealers and the applicable warranties have been breached.

While my client has driven the Vehicle less than 17,000 miles, the Vehicle has experienced major recurring problems with exhaust and emission items, coolant loss, steering gear defects (three repairs), oil leaks, plus other operational issues. In addition, the Vehicle has had a major repair due to a blown head gasket. The Vehicle been repaired at least 20 times, plus routine services, spent over 100 days in the shop, and still has defects.

The defective condition of the Vehicle resulted in it being out of service almost 20% of the total time my client owned it. In addition, the extensive engine related defects cost my client over \$8,300 in out of pocket repair expense. The high cost and loss of availability, forced my client to voluntary return the Vehicle to the lender, and incurred further extensive financial loss.

The Vehicle's repair history is supported by the attached invoice detail reflecting the significant engine and other operational repairs. A summary of the extensive repairs is provided in the attached Vehicle Repair History.

Also attached is a warranty history, obtained by my client, indicating the Vehicle had significant defects prior to him purchasing the Vehicle. This defective condition was not revealed, and was hidden, from my client by the selling dealer.

It is my contention that Ford failed to tender the Vehicle free of defects and its failure to repair the defective Vehicle constitutes a breach of the written and implied warranties covering the Vehicle and is a violation of the MMWA to which Plaintiff is entitled to recover: (1) his damages under 15 U.S.C. §2310(d)(1) or (2) a full refund under 15, U.S.C. §2304(a)(4). My client has performed all things agreed and required of him under the purchase agreement and warranty, except as may have been excused or prevented by the conduct of Ford.

In addition to the protection federal law affords them, my client contends that Ford also violated the State Lemon Laws.

As a direct and proximate result of Ford's violation of its obligations under federal and state law, my client has suffered the following damages:

- A. Cost of repair;
- B. Diminished value of the Vehicle;
- C. Out of pocket expenses;
- D. Loss of use and income; and
- E. Attorney's Fees

Based on the foregoing, my client demands that Ford rescind the transaction by which my client purchased the Vehicle. Upon your agreement to cancel the transaction, my client will return the Vehicle to you in exchange for a full refund of the money paid for this Vehicle, less a reasonable charge for his use of the Vehicle. Alternatively, my client will accept a \$30,000 cash settlement in full and final satisfaction of this claim.

My client has also incurred reasonable and necessary attorney's fees in the pursuit of this claim stated in this letter. The amount of fees and costs incurred as of the date of this letter is \$4,000.00, paid in addition to any cash settlement or repurchase, for total of \$34,000.00.

Under the contract of employment I have with our client, my firm has been assigned an interest in the claim against you.

OFFER OF SETTLEMENT

The purpose of this letter is to encourage you to resolve my client's claim in a fair and equitable manner without the need of further legal action. In the event you fail to take advantage of this offer of settlement, I will have no alternative but to recommend to my client that a lawsuit be filed against you under the Magnuson-Moss-Warranty Act and the DTPA. In this lawsuit, rather than seeking only the amount of compensation I am asking of you at this time, I will seek to recover the full measure of damages to which our client is legally entitled as well as our client's expenses and attorney's fees as allowed by law.

If you are interested in resolving this matter without the necessity of litigation, please contact me with sufficient time to resolve the dispute within thirty (30) days of your receipt of this letter. Thank you for your attention to this letter.

Very truly yours,

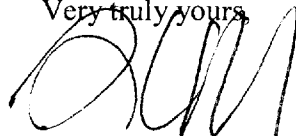
A handwritten signature in black ink, appearing to read 'SLM', written over the typed name below.

Steven L. Marchbanks



CHAPMAN FORD

7100 E. MCDOWELL RD
 SCOTTSDALE, AZ 85257
 (480) 946-3900
 Fax: (480) 945-0736

SERVICE DEPARTMENT HOURS
 7:00 a.m. to 6:00 p.m.
 Monday - Friday
 7:00 a.m. to 3:00 p.m. Saturday

R/O Open Date	R/O Number
9/12/11	6607436/1
R/O Close Date	Status
9/14/11	Reprint
Mileage In	Mileage Out
110704	110712
Service Advisor / Tag #	
ERIC YAW/2884	
Vehicle Identification Number	
1FTWW31R88H	
Delivery Date	In-Service Date
	1/13/11
License Number	

SCOTTSDALE, AZ					
Year	Make	Model	Body	Color	License Number
2008	FORD TRUCK	SPRDY F350 D	CREW CAB SRW 4X4	WHITE	

DESCRIPTION OF SERVICE AND PARTS	AMOUNT
#1 - MR 45FOZZ0: STEERING CONCERN C/S STEERING GEAR BOX IS LOOSE AND HAS EXCESSIVE PLAY IN STEERING- ALSO NOTICES A NOISE AT TIMES FROM PUMP- CHECK AND ADVISE GEAR BOX REPLACED 3/18/11 AT 105972 MILES ON RO 6000074 Work performed by JAMES SWIFT(209) ROADTEST;CK STERRING;NO ABNORMAL PLAY FOUND;STERRI NG HAS TO OVER REACT TO AFTERMARKET STEERING AND S USP, TIGHTENED BOX SLIGHTLY- ROADTESTED WITH SERVICE MANAGER- NO ABNORMAL PLAY FOUND DID NOTICE FRONT TIRES APPEAR TO BE SLIGHTLY OFF ON ALIGNMENT- RECOMMEND HAVING ALIGNMENT RECHECKED- COULD CAUSE SLOWER RESPONSE IN STEERING	

TERMS: STRICTLY CASH UNLESS ARRANGEMENTS ARE MADE. I hereby authorize the repair work hereinafter to be done along with the necessary material and agree that you are not responsible for loss or damage to vehicle or articles left in the vehicle in case of fire, theft, or any other cause beyond your control or for any delays caused by unavailability of parts or delays in parts shipments by the supplier or transporter. I hereby grant you or your employees permission to operate the vehicle herein described on streets, highways, or elsewhere for the purpose of testing and/or inspection. An express mechanic's lien is hereby acknowledged on above vehicle to secure the amount of repairs thereto.	LABOR .00 PARTS .00 DEDUCTIBLE .00 SUBLET .00 SHOP SUPPLIES .00 HAZARDOUS MATERIALS .00 SALES TAX OR TAX I.D. .00 SPECIAL ORDER DEPOSIT .00 DISCOUNTS .00 TOTAL DUE .00
--	--

DISCLAIMER OF WARRANTIES. Any warranties on the products sold hereby are those made by the manufacturer. The seller hereby expressly disclaims all warranties either express or implied, including any implied warranty of merchantability or fitness for a particular purpose, and the seller neither assumes nor authorizes any other person to assume for it any liability in connection with the sale of said products. Any limitation contained herein does not apply where prohibited by law.

NO RETURN ON ELECTRICAL OR SAFETY ITEMS OR SPECIAL ORDERS.

X



CHAPMAN FORD

7100 E. MCDOWELL RD
 SCOTTSDALE, AZ 85257
 (480) 946-3900
 Fax: (480) 945-0738

SERVICE DEPARTMENT HOURS
 7:00 a.m. to 6:00 p.m.
 Monday - Friday
 7:00 a.m. to 3:00 p.m. Saturday

R/O Open Date	R/O Number
6/20/11	6604000/1
R/O Close Date	Status
6/23/11	Reprint
Mileage In	Mileage Out
108775	108775
Service Advisor / Tag #	
ERIC YAW/2063	

SCOTTSDALE, AZ			Work Phone		
Year	Make	Model	Body	Color	License Number
2008	FORD TRUCK	SPRDTY F350 D	CREW CAB SRW 4X4	WHITE	

DESCRIPTION OF SERVICE AND PARTS	AMOUNT
#1 - MR 45FOZZ0: STEERING CONCERN C/S STEERING WHEEL HAS EXCESSIVE PLAY IN IT CHECK AND ADVISE- SEE HISTORY STEERING GEAR REPLACED 6000074 3/15/11 AT 105972 MILES INSPECT STEERING AND SUSP;NO EXCESSIVE PLAY FOUND;HAS SLIGHT MOVEMENT IN GEAR-NORMAL ADJ P/S GEAR AS REQUESTED-1.4	

#2 - MR 45FOZ02: MULTI POINT INSPECT Sub Total: Labor: .00 Parts: .00 Total: .00	
---	--

TERMS: STRICTLY CASH UNLESS ARRANGEMENTS ARE MADE. "I hereby authorize the repair work hereinafter to be done along with the necessary material and agree that you are not responsible for loss or damage to vehicle or articles left in the vehicle in case of fire, theft, or any other cause beyond your control or for any delays caused by unavailability of parts or delays in parts shipments by the supplier or transporter. I hereby grant you or your employees permission to operate the vehicle herein described on streets, highways, or elsewhere for the purpose of testing and/or inspection. An express mechanic's lien is hereby acknowledged on above vehicle to secure the amount of repairs thereto."

DISCLAIMER OF WARRANTIES. Any warranties on the products sold hereby are those made by the manufacturer. The seller hereby expressly disclaims all warranties either express or implied, including any implied warranty of merchantability or fitness for a particular purpose, and the seller neither assumes nor authorizes any other person to assume for it any liability in connection with the sale of said products. Any limitation contained herein does not apply where prohibited by law.

LABOR	.00
PARTS	.00
DEDUCTIBLE	.00
SUBLET	.00
SHOP SUPPLIES	.00
HAZARDOUS MATERIALS	.00
SALES TAX OR TAX I.D.	.00
SPECIAL ORDER DEPOSIT	.00
DISCOUNTS	.00
TOTAL DUE	.00

NO RETURN ON ELECTRICAL OR SAFETY ITEMS OR SPECIAL ORDERS.

X



CHAPMAN FORD

7100 E. MCDOWELL RD
 SCOTTSDALE, AZ 85257
 (480) 946-3900
 Fax: (480) 945-0736

SERVICE DEPARTMENT HOURS
 7:00 a.m. to 6:00 p.m.
 Monday - Friday
 7:00 a.m. to 3:00 p.m. Saturday

R/O Open Date	R/O Number
3/15/11	6000074/1
R/O Close Date	Status
3/18/11	Reprint
Mileage In	Mileage Out
105972	105972
Service Advisor / Tag #	
ERIC YAW/2195	
Vehicle Identification Number	
1FTWW31R88E	
Delivery Date	In-Service Date
	1/13/11
License Number	

SCOTTSDALE, AZ		Work Phone	
Year	Make	Model	Body
2008	FORD TRUCK	SPRDTY F350 D	CREW CAB SRW 4X4
		Color	WHITE

DESCRIPTION OF SERVICE AND PARTS	AMOUNT
#1 - MR 45FOZZ0: STEERING CONCERN C/S STEERING WHEEL HAS EXCESIVE PLAY- CHECK AND ADVISE Work performed by JAMES SWIFT(209) Work performed by JAMES SWIFT(209) Installed 7C3Z 3504 BRM :GEAR ASY - STEERING Installed XT 5 QMC :FLUID - TRANSMISSION REPLACE P/S GEAR FOR EXCESSIVE PLAY;PURGE SYSTEM ROADTEST	150.00 367.72 7.50

TERMS: STRICTLY CASH UNLESS ARRANGEMENTS ARE MADE. I hereby authorize the repair work hereinafter to be done along with the necessary material and agree that you are not responsible for loss or damage to vehicle or articles left in the vehicle in case of fire, theft, or any other cause beyond your control or for any delays caused by unavailability of parts or delays in parts shipments by the supplier or transporter. I hereby grant you or your employees permission to operate the vehicle herein described on streets, highways, or elsewhere for the purpose of testing and/or inspection. An express mechanic's lien is hereby acknowledged on above vehicle to secure the amount of repairs thereto.

DISCLAIMER OF WARRANTIES. Any warranties on the products sold hereby are those made by the manufacturer. The seller hereby expressly disclaims all warranties either express or implied, including any implied warranty of merchantability or fitness for a particular purpose, and the seller neither assumes nor authorizes any other person to assume for it any liability in connection with the sale of said products. Any limitation contained herein does not apply where prohibited by law.

LABOR	150.00
PARTS	375.22
DEDUCTIBLE	.00
SUBLET	.00
SHOP SUPPLIES	.00
HAZARDOUS MATERIALS	.00
SALES TAX OR TAX I.D.	33.58
SPECIAL ORDER DEPOSIT	.00
DISCOUNTS	.00
TOTAL DUE	558.80
Visa 040119	558.80

NO RETURN ON ELECTRICAL OR SAFETY ITEMS OR SPECIAL ORDERS.

X



CHAPMAN FORD

7100 E. MCDOWELL RD
 SCOTTSDALE, AZ 85257
 (480) 946-3900
 Fax: (480) 945-0736

SERVICE DEPARTMENT HOURS
 7:00 a.m. to 6:00 p.m.
 Monday - Friday
 7:00 a.m. to 3:00 p.m. Saturday

R/O Open Date	R/O Number
3/04/10	423949/1
R/O Close Date	Status
3/15/10	Reprint
Mileage In	Mileage Out
95445	95445
Service Advisor / Tag #	

SCOTTSDALE, AZ		Work Phone		Vehicle Identification Number	
				1FTWW31R88E	
				Delivery Date	In-Service Date
					1/13/11
Year	Make	Model	Body	Color	License Number
2008	FORD TRUCK	SPRDY F350 D	CREW CAB SRW 4X4	WHITE	

DESCRIPTION OF SERVICE AND PARTS	AMOUNT
#1 - MR 13FOZ06: DSL ENG FLUID LEAK C/S ENGINE HAS AN OIL LEAK FROM REAR OF ENGINE Caused by INSP FOR OIL LEAK, FOUND BED PLATE SEALS, AND TURBO OIL FEED TUBE LEAKING OIL, ONCE REMOVE ALSO FOUND REAR MAIN SEAL LEAK ING. NESS TO R&I CAB AND ENGINE TO MAKE REPAIR. M-TIME TO REMOVE ADD ON AIR Work performed by (104) REPLACE BED SEALS, FRONT & REAR COVER GASKETS, REAR MAIN SEA L, FRONT CRANK SEAL, HIGH PRESSURE FUEL PUMP COVER GASKETS, AND FEUL LINES AS PER MANUAL, BLEED P/S, FUEL SYSTEM, ROAD TEST, REINSP,	Warranty
#2 - MR 13FOZ07: MULTI POINT INSPECT Sub Total: Labor: .00 Parts: .00 Total: .00 PERFORM MULTI-POINT INSPECTION (INSPECTION SHEET) PERFORMED MULTI-POINT INSPECTION	
#3 - MR 45FOZ01: STEERING CONCERN Sub Total: Labor: .00 Parts: .00 Total: .00 C/S LUBE SUSPENSION INSPE	
#4 - MR 70FOZ03A: TAP DAY RENTAL TAP RENTAL	

TERMS: STRICTLY CASH UNLESS ARRANGEMENTS ARE MADE. *I hereby authorize the repair work hereinafter to be done along with the necessary material and agree that you are not responsible for loss or damage to vehicle or articles left in the vehicle in case of fire, theft, or any other cause beyond your control or for any delays caused by unavailability of parts or delays in parts shipments by the supplier or transporter. I hereby grant you or your employees permission to operate the vehicle herein described on streets, highways, or elsewhere for the purpose of testing and/or inspection. An express mechanic's lien is hereby acknowledged on above vehicle to secure the amount of repairs thereto.*	LABOR	2777.49
DISCLAIMER OF WARRANTIES. Any warranties on the products sold hereby are those made by the manufacturer. The seller hereby expressly disclaims all warranties either express or implied, including any implied warranty of merchantability or fitness for a particular purpose, and the seller neither assumes nor authorizes any other person to assume for it any liability in connection with the sale of said products. Any limitation contained herein does not apply where prohibited by law.	PARTS	.00
	DEDUCTIBLE	.00
	SUBLET	.00
	SHOP SUPPLIES	.00
	HAZARDOUS MATERIALS	.00
	SALES TAX OR TAX I.D.	.00
	SPECIAL ORDER DEPOSIT	.00
	DISCOUNTS	.00
	TOTAL DUE	2777.49

NO RETURN ON ELECTRICAL OR SAFFTY ITEMS OR SPECIAL ORDERS.
 X



RONALD S. WEISS
ATTORNEY AND COUNSELOR
7035 ORCHARD LAKE ROAD
SUITE 600
WEST BLOOMFIELD, MICHIGAN 48322

(248) 737-8000
FAX: (248) 737-8003

OHIO ADDRESS
6725 WEST CENTRAL AVENUE
SUITE M-310
TOLEDO, OHIO 43617

November 13, 2012

Jody Banciu
Ford Motor Company
3 Parklane Blvd.
Parklane Towers West, Suite 1500
Dearborn, MI 48126

Re: My client: [REDACTED]
Vehicle: 2008 Ford F 350
VIN: 1FTWW31R68E [REDACTED]
Dealer: Camelback Ford Lincoln Mercury

Dear Ms. Banciu:

My client took delivery of the above new vehicle. After my client purchased the vehicle, he experienced steering problems, as well as other problems. The vehicle has been in the shop over 4 times for the same repairs. The problems are ongoing and my client is very concerned about this vehicle.

These constant problems have left my client with a very reasonable insecure feeling about this new vehicle. The problems have occurred repeatedly after the repair attempts. My client would like to get out of this vehicle.

It is my goal to resolve this matter without the need for the filing of a lawsuit. Obviously, if we resolve the situation without filing a lawsuit, then my attorney fees and costs would be significantly less than they would be if a lawsuit were filed.

Please contact my office at your earliest opportunity to discuss this matter. I will diary my file ahead 21 days before taking any further action. Thank you in advance for your attention and cooperation in this matter.

Very truly yours,

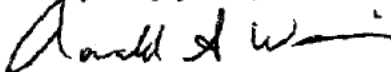
Ronald S. Weiss

RSW:lad

NORTHERN MOTOR COMPANY

1419 LUDINGTON STREET
ESCANABA, MI 49829
PHONE: (906) 786-1130
FAX: (906) 786-7788

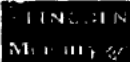

SERVICE DEPARTMENT HOURS
7:30 a.m. to 5:30 p.m.
Monday - Friday

R.O. Open Date	R.O. Number
7/07/09	6007449
R.O. Close Date	Status
8/17/09	Reprint
Message No.	Message Qty
10153	10155

DAN WHITE

Vehicle Identification Number
1FTWW31R68E

Delivery Date Invoice Date

Color
BLACK

WELLS, MI

Year	Make	Model	Body	Color	Invoice Number
2008	FORD	SUPER DUTY F-	4WD CREW CAB	BLACK	

DESCRIPTION OF SERVICE AND PARTS

AMOUNT

#1 - MF 18*: DRIVEABILITY

CUSTOMER STATES WHEN TAKING OFF FROM A STOP THERE
IS A CHATTERING SENSATION

Caused by

TEST DROVE VEHICLE VERIFIED THE CHATTER WHEN CORNE
RING UNDER ACCELERATION

Corrected by 4205A: (K03) (69)

Work performed by ERIC PARROTTA(118) M248689

Corrected by 4205A12B:

Work performed by ERIC PARROTTA(118) M248689

Installed F81Z 4947 AA (FP):KIT - AXLE DIFFERENTIAL Qty: 1

Installed XY 75W140 QL :OIL - REAR AXLE Qty: 4

Installed XL 3 :ADDITIVE - OIL - FRICTION MODI Qty: 3

Installed TA 29 :SEALANT - SILICONE Qty: 1

REMOVED AXLES AND DIFF REPLACED AND ADJUSTED DIFF
CLUTCHES

ALJUST BACKLASH

Warranty

Warranty

Warranty

Warranty

Warranty

#2 - MF 19*: STEERING

CUSTOMER STATES WHEN TURNING A CORNER THE STEERING
WHEEL SHAKES VIOLENTLY

Caused by

TEST DROVE VEHICLE VERIFIED THE SHAKE IN WHEEL WHE
N TURNING

Corrected by 3651A:

Work performed by ERIC PARROTTA(118) M248689

Installed 8C3Z 3E651 E (FP):DAMPER ASY Qty: 1

REPLACED STEERING DAMPNER TO BE REPLACED

Warranty

Warranty

TERMS: STRICTLY CASH UNLESS ARRANGEMENTS ARE MADE. I hereby authorize the repair work hereinafter to be done along with the necessary material and agree that you are not responsible for loss or damage to vehicle or articles left in the vehicle in case of fire, theft, or any other cause beyond your control or for any delays caused by unavailability of parts or delays in parts shipments by the carrier or transporter. I hereby grant you or your employees permission to operate the vehicle herein described on streets, highways, or elsewhere for the purpose of testing and/or inspection. An express mechanic's lien is hereby acknowledged on above vehicle to secure the amount of repair indicated.

DISCLAIMER OF WARRANTIES: Any warranties on the products sold hereby are those made by the manufacturer. The seller hereby expressly disclaims all warranties either express or implied, including any implied warranty of merchantability or fitness for a particular purpose, and the seller neither assumes nor authorizes any other person to assume for it any liability in connection with the sale of said products. Any limitation contained herein does not apply where prohibited by law.

LABOR	
PARTS	
DEDUCTIBLE	
SUBLET	
SHOP SUPPLIES	
HAZARDOUS MATERIALS	
SALES TAX OR TAX ID.	
SPECIAL ORDER DEPOSIT	
DISCOUNTS	
TOTAL DUE	

NO RETURN ON ELECTRICAL OR SAFETY ITEMS OR SPECIAL ORDERS

X

NORTHERN MOTOR COMPANY

1419 LUDINGTON STREET
 ESCANABA, MI 49829
 PHONE: (906) 786-1130
 FAX: (906) 786-7788

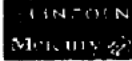
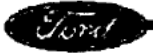

SERVICE DEPARTMENT HOURS
 7:30 a.m. to 5:30 p.m.
 Monday - Friday

R.O. Open Date	R.O. Number
8/12/09	6008019
R.O. Close Date	Status
8/26/09	Reprint
Message In	Message Out
12458	12459
Service Advisor / Tech #	
TRAVIS LEVESQUE	

WELLS, MI			Work Phone	1FTWW31R68E	
Year	Make	Model	Body	Color	License Number
2008	FORD	SUPER DUTY F-	4WD CREW CAB	BLACK	

DESCRIPTION OF SERVICE AND PARTS	AMOUNT
<p>#1 - MF 05*: BRAKE SYSTEM CHECK CUSTOMER STATES THE BRAKE PEDAL IS HARD INTE RMINTANTLY Caused by BRAKE PEDAL IS TO FIRM WHEN BRAKING AND STEERING W HEEL BOUNCES WHEN BRAKING, FOUND BRAKE BOOST INOP NOT WORKING CAUSING HARD BRAKE OPS Corrected by 2005AA: Wcrk performed by ERIC PARROTTA(118) M248689 Installed 7C3Z 2005 AA (FP):BOOSTER ASY - BRAKE REPLACED HYDRAULIC BRAKE BOOSTER</p>	<p>Warranty Warranty</p>

TERMS: STRICTLY CASH UNLESS ARRANGEMENTS ARE MADE. I hereby authorize the repair work hereinafter to be done along with the necessary material and agree that you are not responsible for loss or damage to vehicle or articles left in the vehicle in case of fire, theft, or any other cause beyond your control or for any delays caused by unavailability of parts or delays in parts shipments by the supplier or transporter. I hereby grant you or your employees permission to operate the vehicle herein described on streets, highways, or elsewhere for the purpose of testing and/or inspection. An express mechanic's lien is hereby acknowledged on above vehicle to secure the amount of repairs thereto.

DISCLAIMER OF WARRANTIES: Any warranties on the products sold hereby are those made by the manufacturer. The seller hereby expressly disclaims all warranties either express or implied, including any implied warranty of merchantability or fitness for a particular purpose, and the seller neither assumes nor authorizes any other person to assume for it any liability in connection with the sale of said products. Any imitation contained herein does not apply where prohibited by law.

LABOR	
PARTS	
DEDUCTIBLE	
SUBLET	
SHOP SUPPLIES	
HAZARDOUS MATERIALS	
SALES TAX OR TAX I.D.	
SPECIAL ORDER DEPOSIT	
DISCOUNTS	
TOTAL DUE	

NO RETURN ON ELECTRICAL OR SAFETY ITEMS OR SPECIAL ORDERS

X

NORTHERN MOTOR COMPANY

1419 LUDINGTON STREET
 ESCANABA, MI 49829
 PHONE: (906) 786-1130
 FAX: (906) 786-7788

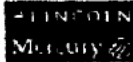

SERVICE DEPARTMENT HOURS
 7:30 a.m. to 5:30 p.m.
 Monday - Friday

R/O Open Date	R/O Number
3/02/10	6011439/
R/O Close Date	Status
3/08/10	Reprint
Machine In	Machine Out
20738	20740
Service Advisor / Loan #	
GREG BRUCE	

Year	Make	Model	Body	Color	License Number
2008	FORD	SUPER DUTY F-	4WD CREW CAB	BLACK	

Work Phone	Vehicle Identification Number
	1FTWW31R68E
Delivery Date	Warranty Date

DESCRIPTION OF SERVICE AND PARTS

DESCRIPTION OF SERVICE AND PARTS	AMOUNT
#1 - MR 19*: STEERING STEERING WHEEL FEELS LIKE IT CATCHES WHEN TURNING Corrected by 3504A: (H22) (42) Work performed by ERIC PARROTTA(118) M248689 Corrected by 3001A: Work performed by ERIC PARROTTA(118) M248689 Corrected by 3001A6: Work performed by ERIC PARROTTA(118) M248689 Installed 8C3Z 3504 CRM (FP):GEAR ASY - STEERING Qty: 1 Installed 8C3Z 3504 CRM-C :8C3Z 3504 CRM - Core Ch Qty: 1 Installed XT 5 QM :FLUID - TRANSMISSION Qty: 2 Installed 388898 S :SEAL Qty: 1 REMOVED STEERING STABILIZER AND BAR, REMOVED STEERING GEAR TRANSFERED PITMAN ARM AND REPLACED GEAR B OX CHECKED ALIGNMENT ADJUSTED THE TOW, TEST DROVE	Warranty Warranty Warranty Warranty Warranty Warranty
#2 - MF 50LOANER: SERVICE LOANER PROVIDED TO CUSTOMER FOR TRANSPORTATION ASSISTANCE PROGRAM PROVIDED CAR FOR CUSTOMER Caused by TAP DAYS USED = 2 Corrected by : (A99-TAP1) (82) Work performed by ERIC PARROTTA(118) M248689	Warranty

TERMS: STRICTLY CASH UNLESS ARRANGEMENTS ARE MADE. I hereby authorize the repair work hereinafter to be done along with the necessary material and agree that you are not responsible for loss or damage to vehicle or articles left in the vehicle in case of fire, theft, or any other cause beyond your control or for any delays caused by unavailability of parts or delays in parts shipments by the supplier or transporter. I hereby grant you or your employees permission to operate the vehicle herein described on streets, highways, or elsewhere for the purpose of testing and/or inspection. An express mechanic's lien is hereby acknowledged on above vehicle to secure the amount of repairs thereto.

DISCLAIMER OF WARRANTIES. Any warranties on the products sold hereby are those made by the manufacturer. The seller hereby expressly disclaims all warranties either express or implied, including any implied warranty of merchantability or fitness for a particular purpose, and the seller neither assumes nor authorizes any other person to assume for it any liability in connection with the sale of said products. Any limitation contained herein does not apply where prohibited by law.

LABOR	.
PARTS	.
DEDUCTIBLE	.
SUBLET	.
SHOP SUPPLIES	.
HAZARDOUS MATERIALS	.
SALES TAX OR TAX I.D.	.
SPECIAL ORDER DEPOSIT	.
DISCOUNTS	.
TOTAL DUE	.

NO RETURN ON ELECTRICAL OR SAFETY ITEMS OR SPECIAL ORDERS.

X

NORTHERN MOTOR COMPANY

1418 LUDINGTON STREET
 ESCANABA, MI 49829
 PHONE: (906) 786-1130
 FAX: (906) 786-7788

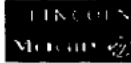

SERVICE DEPARTMENT HOURS
 7:30 a.m. to 5:30 p.m.
 Monday - Friday

R.O. Occur Date:	R.O. Number:
4/19/10	6012267/
R.O. Occur Date:	Status:
4/21/10	Reprint
Invoice #:	Mileage Out:
23678	23679
Service Advisor / Tech #:	
PAT RICHER	

Work Phone:	Vehicle Identification Number:
[REDACTED]	1FTWW31R68E
Delivery Date:	In-Service Date:
[REDACTED]	[REDACTED]

Year	Make	Model	Body	Color	License Number
2008	FORD	SUPER DUTY F-	4WD CREW CAB	BLACK	

DESCRIPTION OF SERVICE AND PARTS	AMOUNT
#1 - MF 15*: ALIGNMENT CUSTOMER STATED STEERING WHEEL IS OFF Wrk performed by DAVE DLUGAS (113) M248851 Sub Total: Labor: 49.95 Parts: .00 Total: 49.95 ALIGNED FRONT END AND STRAIGHTEN STEERING WHEEL.	49.95
#2 - MF 19*: STEERING BCOT IS TORN Wrk performed by DAVE DLUGAS (113) M248851 Wrk performed by DAVE DLUGAS (113) M248851 Installed AC3Z 3304 B :ROD ASY - DRAG LINK NEED INNER DRAG LINK. REPLACED LINK.	35.20 57.20 10214.32 214.32

TERMS: STRICTLY CASH UNLESS ARRANGEMENTS ARE MADE. I hereby authorize the repair work hereinafter to be done along with the necessary material and agree that you are not responsible for loss or damage to vehicle or articles left in the vehicle in case of fire, theft, or any other cause beyond your control or for any delays caused by unavailability of parts or delays in parts shipments by the supplier or transporter. I hereby grant you or your employees permission to operate the vehicle herein described on streets, highways, or elsewhere for the purpose of testing and/or inspection. An express mechanic's lien is hereby acknowledged on above vehicle to secure the amount of repairs thereto.

DISCLAIMER OF WARRANTIES. Any warranties on the products sold hereby are those made by the manufacturer. The seller hereby expressly disclaims all warranties either express or implied, including any implied warranty of merchantability or fitness for a particular purpose, and the seller neither assumes nor authorizes any other person to assume for it any liability in connection with the sale of said products. Any limitation contained herein does not apply where prohibited by law.

LABOR	142.00
PARTS	214.32
DEDUCTIBLE	.00
SUBLET	.00
SHOP SUPPLIES	.00
HAZARDOUS MATERIALS	.00
SALES TAX OR TAX I.D.	12.00
SPECIAL ORDER DEPOSIT	.00
DISCOUNTS	.00
TOTAL DUE	369.32
POLICY SERVICE 3461/6012267	369.32

NO RETURN ON ELECTRICAL OR SAFETY ITEMS OR SPECIAL ORDERS

X

© 2008 NUCON, Inc. - Detroit Association Form #00945-1028

10/13/12 12:09PM

BERGSTROM NEENAH FORD

Page 2

History Report for Vehicle: 8E [REDACTED]

Customer#: [REDACTED]
Customer Name: [REDACTED]

RO Number: 146099

Open Date: 04/29/10 Mileage: 24315 Service Logon: BA115-S
Close Date: 05/06/10 SA Number: 1635 Cashier:

Line Code: A Comeback: N Booker ID:
Complaint: 45FOZ GUEST STATES THE STEERING IS BINDING, HAS HAD SEVERAL REPAIR FOR SAME ISSUE AT OTHER FORD DEALERS BUT STILL DOING IT
Cause: STEERING GEAR DEFECTIVE

Labor Type: W Technician Number: 1842
Op Code: 45FOZ Comeback RO Number:
Description: STEERING/SUSPENSION
Labor\$: 426.15
Parts\$: 393.77
Miscellaneous\$: 90.00

Line Code: B Comeback: N Booker ID:
Complaint: 00FOZ99P COMPLETED MULTI POINT INSPECTION

Labor Type: C Technician Number: 1185
Op Code: 00FOZ99P Comeback RO Number:
Description: GDVC
Labor\$: 0.00
Parts\$: 0.00
Miscellaneous\$: 0.00

Line Code: C Comeback: N Booker ID:
Complaint: 00FOZGBATT BATTERY CONDITION CHECKS OK

Labor Type: C Technician Number: 1121
Op Code: 00FOZGBATT Comeback RO Number:
Description: BATTERY GREEN
Labor\$: 0.00
Parts\$: 0.00
Miscellaneous\$: 0.00

Line Code: D Comeback: N Booker ID:
Complaint: 00FOZGTIRE TIRE CONITION IS OK

Labor Type: C Technician Number: 1121
Op Code: 00FOZGTIRE Comeback RO Number:
Description: TIRES GREEN
Labor\$: 0.00
Parts\$: 0.00
Miscellaneous\$: 0.00

Line Code: E Comeback: N Booker ID:
Complaint: 10FOZ03 GUEST REQUESTS LOANER

Labor Type: W Technician Number: 1121
Op Code: 10FOZ03 Comeback RO Number:
Description: DRIVEABILITY

10/13/12 12 09PM

BERGSTROM NEENAH FORD

Page 3

History Report for Vehicle: 8E [REDACTED]

Customer#: [REDACTED]

Customer Name: [REDACTED]

Labor\$:	0.00
Parts\$:	0.00
Miscellaneous\$:	0.00

Story for Line A, Version Number 1

STEERING WHEEL MOVES BACK AND FORTH SEVERAL INCHES WHEN TURN ING. VEH ON HOIST CAN FEEL STEERING BINDING WHEN TURNING. REMOVE TIRES AND RIGHT TIE ROD END-NO CHANGE, REMOVE LEFT TIE ROD END-STILL NO CHANGE, BALL JOINTS AND U-JOINTS OK, HOTLINE SAYS TO FLUSH THE POWER STEERING PER TSB 08-12-10 AND BLEED AIR FROM SYSTEM. TEST DRIVE AGAIN, NO CHANGE. HOTLINE STATES TO REPLACE THE STEERING GEAR. REMOVE LF TIRE AND INNER SPLASH SHIELD, REMOVE STEERING SHAFT AND DRAG LINK, DISCONNECT POWR STEERING LINES AND GEAR BOX. SWAP PITMAN ARM AND REASSEMBLE BACK INTO TRUCK RELATED PARTS. BLEED AIR FROM POWER STEERING SYSTEM AND RETEST-OK. STEERING WHEEL OFF 45 DEGREES.RESET STEERING WHEEL CLEAR VISION TOOK 3 TIMES.

Story for Line E, Version Number 1

LOANER PROVIDED

NORTHERN MOTOR COMPANY

1419 LUDINGTON STREET
 ESCANABA, MI 49829
 PHONE: (906) 786-1130
 FAX: (906) 786-7788

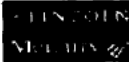

SERVICE DEPARTMENT HOURS
 7:30 a.m. to 5:30 p.m.
 Monday - Friday

RO Order Date	RO Number
10/25/10	6015473/
RO Order Date	State
10/29/10	Reprint
Mileage	Mileage Due
34110	34116
Service Advisor / Tech #	
GREG BRUCE	

WELLS, MI				Vehicle Identification Number	1FTWW31R68E
Year	Make	Model	Body	Color	License Number
2008	FORD	SUPER DUTY F-	4WD CREW CAB	BLACK	

DESCRIPTION OF SERVICE AND PARTS

#1 - MF 19PUMP: POWERSTEERING PUMP
 CUSTOMER STATES POWER STEERING DOES NOT WORK WHEN
 HACKING UP
 Caused by
 TEST DROVE, P/S SYSTEM OPERATES IN BOTH DIRECTION.
 CK.P/S GEAR BOX FREEPLAY.REMOVED DRAGLINK & MEASU
 RED GEAR MESH IN P/S BOX. 4 INLB'S. REMOVED UPPER
 RADIATOR SHROUD. ADJ GEAR BOX TO 10 INLB. REASSEMB
 LE & TEST DROVE.
 Corrected by 3504C:
 Wcrk performed by KEVIN FROSSARD(115) M193945
 ALJ P/S GEAR BOX GEAR MESH PRELOAD TO SPEC.

Warranty

TERMS: STRICTLY CASH UNLESS ARRANGEMENTS ARE MADE. I hereby authorize the repair work hereinafter to be done along with the necessary material and agree that you are not responsible for loss or damage to vehicle or articles left in the vehicle in case of fire, theft, or any other cause beyond your control or for any delays caused by unavailability of parts or delays in parts shipments by the supplier or transporter. I hereby grant you or your employees permission to operate the vehicle herein described on streets, highways, or elsewhere for the purpose of testing and/or inspection. An express mechanic's lien is hereby acknowledged on above vehicle to secure the amount of repair thereto.

DISCLAIMER OF WARRANTIES. Any warranties on the products sold hereby are those made by the manufacturer. The seller hereby expressly disclaims all warranties either express or implied, including any implied warranty of merchantability or fitness for a particular purpose, and the seller neither assumes nor authorizes any other person to assume for it any liability in connection with the sale of said products. Any limitation contained herein does not apply where prohibited by law.

LABOR	
PARTS	
DEDUCTIBLE	
SUBLET	
SHOP SUPPLIES	
HAZARDOUS MATERIALS	
SALES TAX OR TAX I.D.	
SPECIAL ORDER DEPOSIT	
DISCOUNTS	
TOTAL DUE	

NO RETURN ON ELECTRICAL OR SAFETY ITEMS OR SPECIAL ORDERS.

X

NORTHERN MOTOR COMPANY

1419 LUDINGTON STREET
 ESCANABA, MI 49829
 PHONE: (906) 786-1130
 FAX: (906) 786-7788

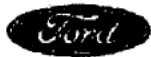

SERVICE DEPARTMENT HOURS
 7:30 a.m. to 5:30 p.m.
 Monday - Friday

R.O. Open Date	R.O. Number
11/04/10	6015686/
R.O. Close Date	Status
11/26/10	Reprint
Mileage In	Mileage Out
35100	35109
Service Advisor / Tech #	
TRAVIS LEVESQUE	

WELLS, MI				Work Order #	1FTWW31R68E
Year	Make	Model	Body	Color	License Number
2008	FORD	SUPER DUTY F-	4WD CREW CAB	BLACK	

DESCRIPTION OF SERVICE AND PARTS	AMOUNT
<p>#1 - ME 19*: STEERING</p> <p>CUSTOMER STATES WHEN COMING TO A STOP AND GOING TO TURN, HE COMPLETELY LOSES POWER STEERING.</p> <p>Caused by CK WAS ABLE TO DUPLICATE CONCERN BY TURNING TO RIGHT STOP, THEN TURNING BACK 90DEG. POWER ASSIST STOPPS. IF BRAKE PEDAL IS PUMPED 5 TO 6 TIMES THEN STEERING ASSIST RETURNS. AFTER DUPLICATING THIS CONCERN SEVERAL TIMES. THE VEHICLE WOULD NOT ACT UP AGAIN. PREFORMED PPT B1-NO, B2-NO. CONTACTED HOTLINE. SUGGEST LOOKING FOR RESTRICTION IN SUPPLY HOSE. PREFORME FLOW TEST. IF PASSES THEN REPLACE THE HYDROBOOST.</p> <p>Corrected by 2005AA: Work performed by KEVIN FROSSARD(115) M193945</p> <p>Corrected by 3504A: Work performed by KEVIN FROSSARD(115) M193945</p> <p>Corrected by 3674A: Work performed by KEVIN FROSSARD(115) M193945</p> <p>Corrected by 3674D: Work performed by KEVIN FROSSARD(115) M193945</p> <p>Installed 7C3Z 2005 AA :BOOSTER ASY - BRAKE Qty: 1</p> <p>Installed N803257 S :SEAL 8.0X1.78 "O" RING Qty: 2</p> <p>Installed XT 5 QM :FLUID - TRANSMISSION Qty: 4</p> <p>Installed 7C3Z 3A674 D :PUMP ASY - POWER STEERING Qty: 1</p> <p>Installed 7C3Z 3A674 D-C :7C3Z 3A674 D - Core Char Qty: 1</p> <p>Installed 7C3Z 3A717 C :HOSE ASY Qty: 1</p> <p>Installed 7C3Z 3F887 E :KIT - POWER STEERING HOSE Qty: 1</p> <p>Installed 8C3Z 3504 CRM :GEAR ASY - STEERING Qty: 1</p>	<p>Warranty</p> <p>Warranty</p> <p>Warranty</p> <p>Warranty</p> <p>Warranty</p> <p>Warranty</p> <p>Warranty</p> <p>Warranty</p> <p>Warranty</p> <p>Warranty</p> <p>Warranty</p> <p>Warranty</p> <p>Warranty</p>

TERMS: STRICTLY CASH UNLESS ARRANGEMENTS ARE MADE. I hereby authorize the repair work hereinafter to be done along with the necessary material and agree that you are not responsible for loss or damage to vehicle or articles left in the vehicle in case of fire, theft, or any other cause beyond your control or for any delays caused by unavailability of parts or delays in parts shipments by the supplier or transporter. I hereby grant you or your employees permission to operate the vehicle herein described on streets, highways, or elsewhere for the purpose of testing and/or inspection. An express mechanic's lien is hereby acknowledged on above vehicle to secure the amount of repair thereon.

DISCLAIMER OF WARRANTIES. Any warranties on the products sold hereby are those made by the manufacturer. The seller hereby expressly disclaims all warranties either express or implied, including any implied warranty of merchantability or fitness for a particular purpose, and the seller neither assumes nor authorizes any other person to assume for it any liability in connection with the sale of said products. Any limitation contained herein does not apply where prohibited by law.

LABOR	
PARTS	
DEDUCTIBLE	
SUBLET	
SHOP SUPPLIES	
HAZARDOUS MATERIALS	
SALES TAX OR TAX I.D.	
SPECIAL ORDER DEPOSIT	
DISCOUNTS	
TOTAL DUE	

NO RETURN ON ELECTRICAL OR SAFETY ITEMS OR SPECIAL ORDERS

X

NORTHERN MOTOR COMPANY

1419 LUDINGTON STREET
 ESCANABA, MI 49829
 PHONE: (906) 786-1130
 FAX: (906) 786-7788



SERVICE DEPARTMENT HOURS
 7:30 a.m. to 5:30 p.m.
 Monday - Friday

RO Order Date	RO Number
11/04/10	6015686
RO Order Date	Order
11/26/10	Reprint
Michigan	Michigan
35100	35109

TRAVIS LEVESQUE

Vehicle Identification Number

1FTWW31R68E

Delivery Date Invoice Number

Work Phone
 [Redacted]
 [Redacted]

Year	Make	Model	Body	Color	License Number
2008	FORD	SUPER DUTY F-	4WD CREW CAB	BLACK	

DESCRIPTION OF SERVICE AND PARTS

Installed 8C3Z 3504 CRM-C :8C3Z 3504 CRM - Core Ch Qty: 1
 Installed W711886 S439 :BOLT Qty: 3
 Installed W709296 S441 :NUT Qty: 1
 Installed XC3Z 7B155 G :FILTER ASY - OIL Qty: 1
 FCUND & HOOKED UP P/S FLOW TESTER.
 STARTED TO PRESSURE TEST. TESTER STARTED TO LEAK.
 REPLACED HOSE ON TESTER.
 PFEFORMED P/S PUMP PERFORMANCE TEST. PUMP FLOW/PRE
 SEURE & PRESSURE RELIEF IS IN SPEC.
 NEED TO REPLACE THE HYDRO BOOST.REMOVED FLOW TESTE
 R. BLEED P/S SYSTEM.PUMP NOISY,REBLEED SYSTEM ASPE
 R WSM. STILL NOISY. REPLACED THE HYDROBOOSTER,BLEE
 D THE P/S SYSTEM.STILL LOOSES ASSIST AFTER REACHIN
 G FULL RIGHT TURN THEN TURNING LEFT.TEST DROVE,STA
 P,S PUMP STARTED TO GROWL.INSPECT P/S SYSTEM AGAIN
 . REMOVED P/S RESIVORE. FOUND DEBRY IN BOTTOM OF R
 ESIVORE. REPLACED THE P/S PUMP,PRESSURE LINE BETWE
 EM PUMP & HYDROBOOST & REPLACED THE P/S GEAR.BLEED
 P/S SYSTEM INSTALLED TEMP FILTER IN P/S COOLER R
 ETURN LINE. FILTERED FLUID. REMOVED FILTER. SET AL
 ICHNMENT.TEST DROVE, STEARS NORMAL. NO NOISE. CK F
 OE LEAKS. ALL OK.

AMOUNT
Warranty
Warranty
Warranty
Warranty

#2 * MR 50LOANER: SERVICE LOANER PROVIDED TO CUSTOMER FOR
 TRANSPORTATION ASSISTANCE PROGRAM

Caused by
 16 TAP DAYS USED

Work performed by KEVIN FROSSARD(115) M193945

Warranty

TERMS: STRICTLY CASH UNLESS ARRANGEMENTS ARE MADE. I hereby authorize the repair work hereinafter to be done along with the necessary material and agree that you are not responsible for loss or damage to vehicle or articles left in the vehicle in case of fire, theft, or any other cause beyond your control or for any delays caused by unavailability of parts or delays in parts shipments by the supplier or transporter. I hereby grant you or your employees permission to operate the vehicle herein described on streets, highways, or elsewhere for the purpose of testing and/or inspection. An express mechanic's lien is hereby acknowledged on above vehicle to secure the amount of repairs thereto.

DISCLAIMER OF WARRANTIES. Any warranties on the products sold hereby are those made by the manufacturer. The seller hereby expressly disclaims all warranties either express or implied, including any implied warranty of merchantability or fitness for a particular purpose, and the seller neither assumes nor authorizes any other person to assume for it any liability in connection with the sale of said products. Any limitation contained herein does not apply where prohibited by law.

LABOR	.
PARTS	.
DEDUCTIBLE	.
SUBLET	.
SHOP SUPPLIES	.
HAZARDOUS MATERIALS	.
SALES TAX OR TAX I.D.	.
SPECIAL ORDER DEPOSIT	.
DISCOUNTS	.
TOTAL DUE	.

NO RETURN ON ELECTRICAL OR SAFETY ITEMS OR SPECIAL ORDERS

X



BEGINNING OF CONTACT
09/17/2008

VOICE OF THE CUSTOMER TRACKING SYSTEM

08.36.54

REGION: C2 HOUSTON	OGC ISSUE	CASE NBR: 1606812608
VIN: 1FTWW31RX8E	ZONE: A06	OPENED: 09/16/2008
	ENGINE: R	CLOSED: 09/16/2008
	VEH TYPE: T	

LAST NAME:		FIRST NAME:		STATUS:	CLOSED
TITLE:				MI:	
ADDRESS:		STATE:	TX	ZIP:	
CITY:	ALICE	MODEL:	F350 4X4 CREWCAB - SRW		
HOME PHONE:		SALES CODE:	F52099	P & A:	04406
MODEL YEAR:	2008				
MILEAGE:	35400				
DEALER NAME:	BOWDEN FORD LINCOLN				
REASON CODE:	0772 LEGAL - ACCIDENT				
SYMPTOMS:	303155 STRG/HANDLING FUNCTION LOSS OF STRG				

ORIGIN: CACI38 - US CONCERN CASE BASE COMMUNICATION: PHONE
 ACTION: 791 - ADVISE CUSTOMER INFO WILL BE SENT TO OGC
 DOCUMENT: ANALYST: WCONN2 CONN WILLIAM

FORD MOTOR COMPANY
 RECEIVED
 09/17/2008

DATE: 09/16/2008 TIME: 16.51.20 :
 ACTION DATA/COMMENTS:

SEP 17 2008

OFFICE OF THE
 GENERAL COUNSEL

FIRE / ACCIDENT A
 CUSTOMER SAID: - STEERING WENT OUT CAUSING CUST TO HAVE AN ACCIDENT, VEH WAS TOWED INTO NEAREST DLR ON 09/15- WHILE DRIVING. CUST COULD TURN THE STEERING WHEEL BUT THE VEH DID NOT TURN, CUST LOST CONTROL- VEH RAN OFF ROAD TO THE LEFT AND HIT A TREE STUMP, NOTHING ELSE DAMAGED- CUST WAS NOT INJURED, WAS ONLY GOING ABOUT 35MPH WHEN STEERING WENT OUT, AIRBAGS DID NOT DEPLOY- THERE WAS NO POLICE REPORT- DLR JUST CALLED AND SAID IT WOULD NOT BE WARRANTABLE BECAUSE VEH WAS IN AN ACCIDENT- CUST SAYS THAT ACCIDENT OCCURED BECAUSE THE STEERING WENT OUT, NOT THE OTHER WAY AROUND- CUST HAS NOT CONSULTED WITH HIS INSURANCE COMPANY BECAUSE HE WILL HAVE TO PAY A DEDUCTIBLE- CUST IS NOT SEEKING TO HAVE OTHER DAMAGES TO VEH REPAIRED BY FORD, BUT WANTS THE STEERING FIXED UNDER WARRANTY- CUST IS TRYING TO AVOID A LEGAL MATTERDEALER SAID: BOWDEN FORD LINCOLN MERCURY CO.1300 E MAIN STREET ALICE, TX 78332TEL : (361) 664-9541CRC ADVISED: - I WILL FORWARD THIS INFORMATION TO THE FORD OFFICE OF THE GENERAL COUNSEL. YOU WILL RECEIVE WRITTEN NOTIFICATION WITHIN 10 BUSINESS DAYS WHICH YOU WILL NEED TO RESPOND TO IN WRITING.NOTE TO CCR: REMEMBER TO VERIFY ALL CUSTOMER CONTACT INFORMATION BEFORE SENDING ISSUE.*
 *****OBC TO DLR- SPOKE TO S/A OMAR- VEH HAS LIFTED SUSPENSION AND OVERSIZE TIRES ON IT, WHICH MAY HAVE CONTRIBUTED TO PROBLEM / FAILURE- OMAR AND BODY SHOP MGR LOOKED AT BUMPER AND IT HAS INDICATIONS OF RED AND GREEN THAT APPEAR TO BE PAINT, OMAR THOUGHT VEH HAD HIT A PARKED CAR UNTIL CRC CALLED- WARRANTY CLAIM HAS BEEN DENIED AS DAMAGE FROM THE ACCIDENT- VEH NEEDS A NEW STEERING GEARBOX***** AGENT NOTES. SPEAKING TO THE TOW COMPANY ABOUT THE CIRCUMSTANCES OF THE ACCIDENT MAY HELP CLEAR UP SOME OF THE MYSTERY ****



STATE OF NORTH DAKOTA

IN DISTRICT COURT

COUNTY OF STUTSMAN

SOUTHEAST JUDICIAL DISTRICT

████████████████████

Civil No. _____

Plaintiff,

COMPLAINT

vs.

Ford Motor Company,

Defendant.

Plaintiff, for its claim against defendant, alleges as follows:

I.

That defendant Ford Motor Company, (hereinafter referred to as Ford), a corporation licensed to do business in North Dakota, designed, manufactured, produced, and supplied a 2008 Ford F-250 4x4 four door crew cab, 6.4 liter, 8 cylinder diesel injected turbo charged pickup, VIN 1FTSW21R08E██████████ to the plaintiff.

II.

Said pickup was intended for and reached the plaintiff without substantial change in the condition in which it was manufactured and sold. Plaintiff purchased the vehicle new on or about October, 2007 and was the only owner.

III.

That the pickup was not altered or modified from its purchase until its failure on June 3, 2008.

IV.

That said vehicle was not abused or misused prior to its failure on June 3, 2008.

V.

That defendant, a foreign corporation licensed to do business in the State of North Dakota, produced and/or manufactured and expressly warranted its 2008 Ford F-250 Pickup, VIN 1FTSW21R08E██████████ to be made of good material and workmanship and to be capable of performing and functioning its designed purpose without steering failure.

VI.

That the defendant's express warranty was for three years, 36,000 miles and the vehicle was about seven months old with about 15,500 miles on June 3, 2008.

VII.

That on or about June 3, 2008, at or near rural Alfred, North Dakota, as a result of defendant's breach of warranty, plaintiff's 2008 Ford F-250 Pickup, VIN 1FTSW21R08EA [REDACTED] steering failed without warning resulting in the pickup abruptly going out of control, off the road, submerging itself in water, damaging said pickup in the sum of \$45,194.79, incurring tow bill of \$1,200 and bill of \$439.67.

VIII.

That plaintiff informed defendant of this loss in June, 2008, however, plaintiff did not receive a written response from Ford.

IX.

That defendant defectively produced said 2008 Ford F-250 Pickup, VIN 1FTSW21R08EA [REDACTED] and that such defect was in breach of its warranties express and/or implied, including warranty of merchantability and/or warranty of fitness for a particular purpose and breach of merchantability thereby resulting in a loss to plaintiff in the amount of \$46,834.46.

X.

That the vehicle was financed with Ford Motor Credit who plaintiff was required to pay off after Ford's vehicle, without warning, failed.

XI.

That the plaintiff has preserved the vehicle for inspection, incurred storage costs and has been unable to sell it for salvage until this case is concluded.

WHEREFORE, plaintiff demands judgment against defendant for the sum of \$46,834.46, minus salvage plus storage, plus prejudgment interest at the rate of 6% per annum from the date of the incident on June 3, 2008, together with its costs and disbursements, reasonable attorney's fees herein after allowing all credits and setoffs, and for such other and further relief as the Court deems fair and equitable.

THE PLAINTIFF DOES DEMAND A JURY OF 12 PERSONS OR THE LARGEST JURY ALLOWED BY LAW.

Dated this 30 day of July, 2009.



Marnell W. Ringsak, #03609
Attorney for Plaintiff
411 North 4th Street, P. O. Box 2155
Bismarck, ND 58502-2155
(701) 255-1344

Server: **AWS Prod**
 Claims loaded through: **05-AUG-2009**

STANDARD CLAIMS LIST

AWS Online Report

Run Date: 06-AUG-2009

Note: All Costs are in US Dollars Server Name: AWS Prod Claims loaded through

VIN	AWS VL	WERS VL	MKT DER	BODY CAB	VER SERIES	DRIVE TYPE	PLANT CD	TRANS CD	ENG COD	PROD DATE	WARR DATE	SELLING DEALER	SELL CNT	TIS	WCC	PREF	BASE	SUFF	VRT NA	VRT ROW	VFG	CCC	CD
1FTSW21R08E [REDACTED]	F7	T/F7	F	T/BC	T/BD	T/E	A1	T/BE	T/QL	30-03-07	30-04-07	156751	USA	0	*	*	*	*	F09	SXX	V00	*	*
AWS Claim Key:	47714	Doc #:	03065901	Trx Code:			TDE	Labor Hrs:	0	Labor Cost:	25	Material Cost:	33.14	Total Cost:	58.14								
Dlr Cd-Sub Cd:	07218-*	Name:	PHILIP MOTOR, INC.	Ph:	605-8592585	St:	SD	Ctry Cd:	USA	Reg Cd:	NA	Repr Date:	25-APR-2007	DIST(Mile):	4								
Cust Comments:	RIGHT HAND MIRROR COVER MISSING																						
Tech Comments:	PAINT AND REPLACE RIGHT HAND MIRROR COVER. SUBLET PAINT JOB TO LBS.																						
1FTSW21R08E [REDACTED]	F7	T/F7	F	T/BC	T/BD	T/E	A1	T/BE	T/QL	30-03-07	30-04-07	156751	USA	2	1H03	8C3Z	9D475	A	F04	S11	V29	E29	42
AWS Claim Key:	58042	Doc #:	08815101	Trx Code:			S07	Labor Hrs:	1.7	Labor Cost:	104.34	Material Cost:	194.08	Total Cost:	298.42								
Dlr Cd-Sub Cd:	04107-*	Name:	R. M. STOUDT, INC.	Ph:	701-2522270	St:	ND	Ctry Cd:	USA	Reg Cd:	NA	Repr Date:	11-JUN-2007	DIST(Mile):	2031								
Cust Comments:	CHECK ENGINE LIGHT ON																						
Tech Comments:	6 4L PERFORANCE DIAG PINPOINT ROAD TEST MONITOR PIDS R AND R EGR VALVE RETEST ALL PASSED																						
1FTSW21R08E [REDACTED]	F7	T/F7	F	T/BC	T/BD	T/E	A1	T/BE	T/QL	30-03-07	30-04-07	156751	USA	4	5G05	*	FRONT	*	F05	S10	V89	H26	W6
AWS Claim Key:	112852	Doc #:	09044802	Trx Code:			2	Labor Hrs:	.6	Labor Cost:	36.82	Material Cost:	0	Total Cost:	36.82								
Dlr Cd-Sub Cd:	04107-*	Name:	R. M. STOUDT, INC.	Ph:	701-2522270	St:	ND	Ctry Cd:	USA	Reg Cd:	NA	Repr Date:	22-AUG-2007	DIST(Mile):	6259								
Cust Comments:	STEERING WHEEL ISNT STRAIGHT AND PULLS																						
Tech Comments:	CHECKED ALIGNMENT AND CENTERED STEERING WHEEL SET TOE IN ROAD TEST																						

Any comments? You can contact



webmaster

Server: AWS Prod

Claims loaded through: 05-AUG-2009

Claim Detail Report

*Note: All costs are in US dollars***Model Year = 2008; Claim Key = 112852****Vehicle Information**

Model Year: 2008

Market Derived: F - FORD

Body/Cab Type: T/BC - DOUBLE CAB (CREW CAB)

Version/Series: T/BD-250 SERIES

Drive Type: T/E-4 WHL L/H PART TIME DRIVE

Vehicle Line: T/F7-F250HD/350/450/550 [99-10]

Warranty Start Date: 30-APR-2007

Production Date: 30-MAR-2007

VIN: 1FTSW21R08E [REDACTED]

Dealer Information:Dealer Name R. M. STOUTD, INC.Dealer Code: 04107 - *Address: 800 23RD STREET SWCity: JAMESTOWNState: ND Zip Code:58401Country: USA Region Code: NAPhone: (701)252-2270**Claim Information**Document Number: 09044802Repair Date: 22-AUG-2007Distance: 6259TIS: 4**Expense Information**Customer Paid Amount: .00Deductible Amount: .00Dealer Paid Amount: .00Labor Cost: 36.82Misc. Expense Amount: .00Part Markup Amount: .00Material Cost: .00Total Cost Gross: 36.82

Cust. Concern Code: H26 - CONSTANT PULL TO RIGHT

Condition Code: W6 - WHEEL ALIGNMENT OUT OF SPECIFICATION
 Technician Comment: CHECKED ALIGNMENT AND CENTERED STEERING WHEEL SET TOE IN ROAD TEST
 Customer Comment: STEERING WHEEL ISNT STRAIGHT AND PULLS

<u>Labor Op Code</u>	<u>Labor Op Description</u>	<u>Labor Op Cost</u>
3001A	CASTER, CAMBER, TOE-IN CHECK	24.55
3001A6	TOE-IN CORRECT	12.27

<u>Causal Flag</u>	<u>Full Part Number</u>	<u>Part Description</u>	<u>Part CPSC</u>	<u>Part Quantity</u>	<u>Extended Amount</u>
Y	* FRONT *	FRONT END ALIGNMENT	040001	0	.00

DTC Sections: Mil. Light On = *

Flag Test Type Malfunction Cd Malfunction Cd Description Monitor Cd Monitor Cd Description

Any comments? You can contact



webmaster

21147

JUNE 18, 2008

FORD MOTOR COMPANY
RECEIVED
CLAIMS UNIT

JUN 24 2008

OFFICE OF THE
GENERAL COUNSEL

JUN 25 10:11 AM '08

4
Subsc

FORD MOTOR COMPANY CONSUMER AFFAIRS
P.O. BOX 6248 MD-3NE-B
DEARBORN, MI 48126

RE: Our Claim No: [REDACTED]
Our Policy No: [REDACTED]
Date of Loss: 6/3/08

Dear: Consumer Affairs Manager:

We are writing in regard to a claim of ours involving a 2008 Ford F250
VIN# 1FTSW21R08E [REDACTED]

Our investigation indicates your product may be responsible for the damages incurred by our insured. Therefore, we are placing you on notice of our potential claim against you. I believe the cause of loss is a result of the steering shaft breaking where it enters the steering gear causing the vehicle to leave the road and being submerged in water.

I look forward to hearing from you as we would like to settle this claim but want a representative from your company to inspect the vehicle. This vehicle will be available for your inspection until July 2, 2008. Please contact me ASAP for location and time of inspection.

Sincerely,

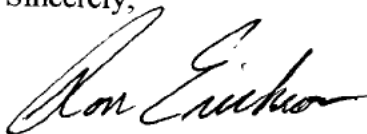

Ross Erickson
Material Damage Appraiser
701-298-4224

65899

1 Q. This is Kathy Vorwerk. I'm speaking with [REDACTED] over the telephone. Um, today's
2 date is June 6 and it's currently 3:37 p.m. We're discussing a accident that happened uh
3 approximately on [REDACTED] uh, and, [REDACTED] am I recording this with your full knowledge and
4 consent?

5 A. Yes.

6 Q. And can you tell me what your name is?

7 A. [REDACTED]

8 Q. Okay, and can you spell that for me?

9 A. [REDACTED]

10 Q. Okay, and what is your date of birth?

11 A. [REDACTED]

12 Q. And what is your address?

13 A. [REDACTED] Jud, North Dakota, [REDACTED]

14 Q. Okay, and what is the number uh is it [REDACTED]

15 A. Yeah, [REDACTED]

16 Q. Okay, and uh, what is your phone number?

17 A. [REDACTED]

18 Q. And is this the best number to reach you at?

19 A. Yeah.

20 Q. Okay, and uh the date of the accident what uh vehicle were you driving?

21 A. Ford 2008 pickup.

22 Q. Okay, is that um is that a F-150 or is that a?

23 A. F-250.

24 Q. F-250? Okay, and uh do you own that?

- 25 A. Yeah.
- 26 Q. Uh, what color is it?
- 27 A. Silver.
- 28 Q. Okay, and now we had down the day of the accident is June 3, 2008, which was Tuesday,
- 29 is that correct?
- 30 A. Right.
- 31 Q. Okay, and do you know what time it happened?
- 32 A. Well, not, there's two two things that happened. First of all it was in about 6:00 at night, I
- 33 was it was muddy on the on the um county road.
- 34 Q. Okay.
- 35 A. And I don't know if you know around here all the roads are getting washed out with the
- 36 wind.
- 37 Q. Okay.
- 38 A. Uh, I had a four-wheel drive and the steering column broke on the pickup, the steering,
- 39 my steering wheel just went round and round and I was getting through the mud and it just slid
- 40 me right off the side of the road and part of the pickup, we pulled it out right away, a neighbor
- 41 come over and pulled it out right away and the front got wet.
- 42 Q. Okay, what, so you slid off the road into a, is it into a ditch or?
- 43 A. Well, yeah, it's kind of it's a slew there.
- 44 Q. Okay.
- 45 A. So we pull it, it's only a half mile from the house, bring it home and we had, we
- 46 unhooked the battery cause everything was flashing like it it had electric current going.
- 47 Q. Okay.

48 A. So I had to leave it in neutral cause if you don't leave it in neutral once the battery's
49 hooked up it won't go into neutral. Next morning wake up and the thing rolled from 10 feet from
50 my driveway down maybe 30 feet and ran into the RA pole.

51 Q. Okay.

52 A. So I called.

53 Q. Is there a slope there?

54 A. Yeah, and I, Ford was supposed to come out that day and or the next morning to pick it
55 up, that's why I did that so I called Ford about this power steering, they haven't got to it yet to
56 see if it's insurance claim or if it's the pickup's fault or what.

57 Q. Okay.

58 A. I, this thing overnight, it, I don't know how, the wind, it didn't move from 5:00 until I
59 went to bed but then in the morning, so we took, we took pictures of, I mean it was muddy here
60 so you can just see right where it rolled 50 feet.

61 Q. Okay, when it initially went off the road, where did that happen at, what county road?

62 A. Hm, it's [REDACTED]

63 Q. Okay, uh, so it's [REDACTED] uh, I?

64 A. Yeah, it's just a half mile south of the house.

65 Q. Half a mile from where you live, okay?

66 A. Yeah.

67 Q. Okay, and had it been acting funny um before that happened or?

68 A. Yeah, the power steering has been, I've been just waiting to take it in there cause it's
69 been leaking.

70 Q. Okay.

71 A. There's something. Sometimes it steers hard and then it, then it doesn't.

- 72 Q. How.
- 73 A. _____ 16,000 miles on it.
- 74 Q. How many?
- 75 A. 16,000.
- 76 Q. Okay, and uh how long has it been leaking?
- 77 A. Hm, I'd say a week.
- 78 Q. Okay, and it's been steering funny or?
- 79 A. Yeah, kinda.
- 80 Q. Okay.
- 81 A. I mean it, it seemed like it never, when you're sitting still, it didn't have the power it
- 82 should to turn turn the wheel.
- 83 Q. Okay, so when it it starts sliding you actually were having trouble and couldn't control
- 84 the steering wheel and then it started sliding or?
- 85 A. Right, yeah, I just lost it, well, the road's only, the county was out the next day and
- 86 started working on fixing the road but the road's only like a one horse trail, I mean it's it's a
- 87 county road but it's only as narrow, about as wide as the pickup and with that mud I was just
- 88 spinning and all of a sudden you know I was keeping it on the road no problem, well then I was
- 89 probably only going about fifteen miles an hour thank goodness and then it just whump no
- 90 steering and just turned the wheel straight over and went right off it.
- 91 Q. Okay, and so you went did it go in um nose first or the back?
- 92 A. Nose.
- 93 Q. Okay, and how long was it in the water?
- 94 A. Hm, I'd say maybe a half hour.
- 95 Q. Okay, and then you uh pulled it out and took it home?

- 96 A. Yeah.
- 97 Q. Okay. Um, was there any damage to the front end from being the slew do you know, any
- 98 body damage to it?
- 99 A. No.
- 100 Q. Okay. Um.
- 101 A. Well, the the well, that running but that's the last time like Nodak wouldn't cover that
- 102 and I wasn't real happy with that either cause they wanted to know if it was in more than one
- 103 wreck, well, that was when I had that load of hay on slid off the road.
- 104 Q. On this one?
- 105 A. Yeah.
- 106 Q. Okay. Same, with the same uh vehicle?
- 107 A. Yep.
- 108 Q. Okay, and so there was?
- 109 A. When we took it out of the water, the the running board came off.
- 110 Q. The running board came off when you took it out of the water, okay. And um and then
- 111 what portion of the vehicle hit the pole?
- 112 A. This, straight straight on the the _____ hitch and the bumper.
- 113 Q. Okay, and it's right in the middle or?
- 114 A. Yeah, right, I mean you couldn't, it has no steering, you couldn't aimed it more better at
- 115 the dumb thing.
- 116 Q. Okay, and that, that was how many feet from where you had it parked?
- 117 A. Maybe 50 feet.
- 118 Q. Okay, was it on a trailer or was it just sitting in the yard?

119 A. No, it was just sitting in my yard and then I called Ford, you know, they got that roadside
120 thing or whatever and and uh woke up in the morning and the dumb thing rolled down the hill.

121 Q. Okay.

122 A. Well, it's not even really a hill, it's just a little slope in my yard.

123 Q. Okay. Uh, did Ford say if they've been having problem with uh with that in those trucks?

124 A. Well, the, mine was one of the new ones that came out and I've been starting to get a
125 whole bunch of recalls on it all way from the seats to the gas tank to so I don't know. I called my
126 dealership down in South Dakota but they hadn't had one yet but mine was one of the first ones
127 off the lot.

128 Q. Okay.

129 A. And that's what my dealer down there, I said that's Ford should cover this whole thing
130 and they said, well, we can't, my dealer down there, said he couldn't tell without looking at it
131 and I said well that's what happened, when you ain't got no steering you can't hardly keep it on
132 the road and he, said well, it's cause of the mud and I said how would I know, it's got off road
133 and I was on a county road so I really don't see what difference that would make.

134 Q. Okay, and were you hurt at all when you went into the slew?

135 A. No.

136 Q. Okay, and uh, you don't know what time it actually rolled from your yard into the pole?

137 A. No, it was over, it was over the night.

138 Q. Okay, and the other one happened about 6:00 in the evening?

139 A. Yeah, 5 or 6, somewhere around in there.

140 Q. Okay, and someone helped, who helped you uh pull it out?

141 A. My mom was here and uh, [REDACTED] pulled it out.

142 Q. Okay, all right, um, I think that is all I need at this point. Uh, now you said, it says on
143 here there is some electrical, mechanical work done is that is that the portion from the the water
144 damage?

145 A. Yeah.

146 Q. Okay, all right, and then um, has anybody looked at the the steering yet? I don't suppose
147 Ford has looked at that?

148 A. Well, it's up there but I called yesterday to see what they and they hadn't even looked at
149 it yet.

150 Q. Okay.

151 A. They were hoping to look at it today so I was gonna wait here another half hour and call
152 up there.

153 Q. Okay, it's at RM Stoudt or?

154 A. Yeah.

155 Q. Okay, all right. All right, is there anything else about how this happened that you wanta
156 add?

157 A. Hm, that's about the extent of it.

158 Q. Okay, and everything, everything that uh that you have answered has been true to the best
159 of your knowledge?

160 A. Yes.

161 Q. Okay, uh, it is now 3:46 p.m. on June 6, gonna shut off the tape recorder.



Office of the General Counsel

PRIVILEGED & CONFIDENTIAL
 Ford Motor Company
 Claims Department
 P.O. Box 70
 Dearborn, Michigan 48121-0070

August 7, 2008

Nodak Mutual Insurance Company
 PO Box 2502
 Fargo, ND 58108-2502
ATTENTION: ROSS ERICKSON

RE: Your Insured: [REDACTED]
 Your Claim #: [REDACTED]
 DOL: 06/03/08

Dear Mr. [REDACTED]

We acknowledge your recently submitted subrogation claim letter. In order to assist us in evaluating your claim, we request that you provide us with the following information: (Please note that the information requested is in regard to the Ford manufactured vehicle.)

- 1. Attach your insured's statement with a complete description of the incident, including events that occurred prior to and subsequent to the loss.
- 2. A copy of the police and/or fire report. *none*
- 3. Original color photographs of the vehicle's collision/fire damage & the alleged defective parts, from several different angles.
- 4. Original color photographs of the inside of the vehicle showing the steering wheel, dash and roof areas.
- 5. Original color photographs of the accident / fire scene from several different angles.
- 6. Attach a copy of your expert's report and the expert's original color photographs.
- 7. Attach the repair estimate, repair order, or your total loss worksheet for the vehicle's damage and any losses associated with this incident, and copies of draft payments.
- 8. Attach the complete service history for the subject vehicle, including any tune-ups or oil changes.

Please answer the following in the space provided. If you need additional space, please use the back of the form;

- 9. What was the city and state of occurrence: North Dakota [REDACTED]
- 10. The 17 digit vehicle identification number: 1FTSW21R08E [REDACTED]
- 11. What was the mileage at time of occurrence: 16,600
- 12. What is the alleged defect: steering shaft breaking
- 13. Has the alleged defective part been repaired or replaced? (circle one) Yes or No

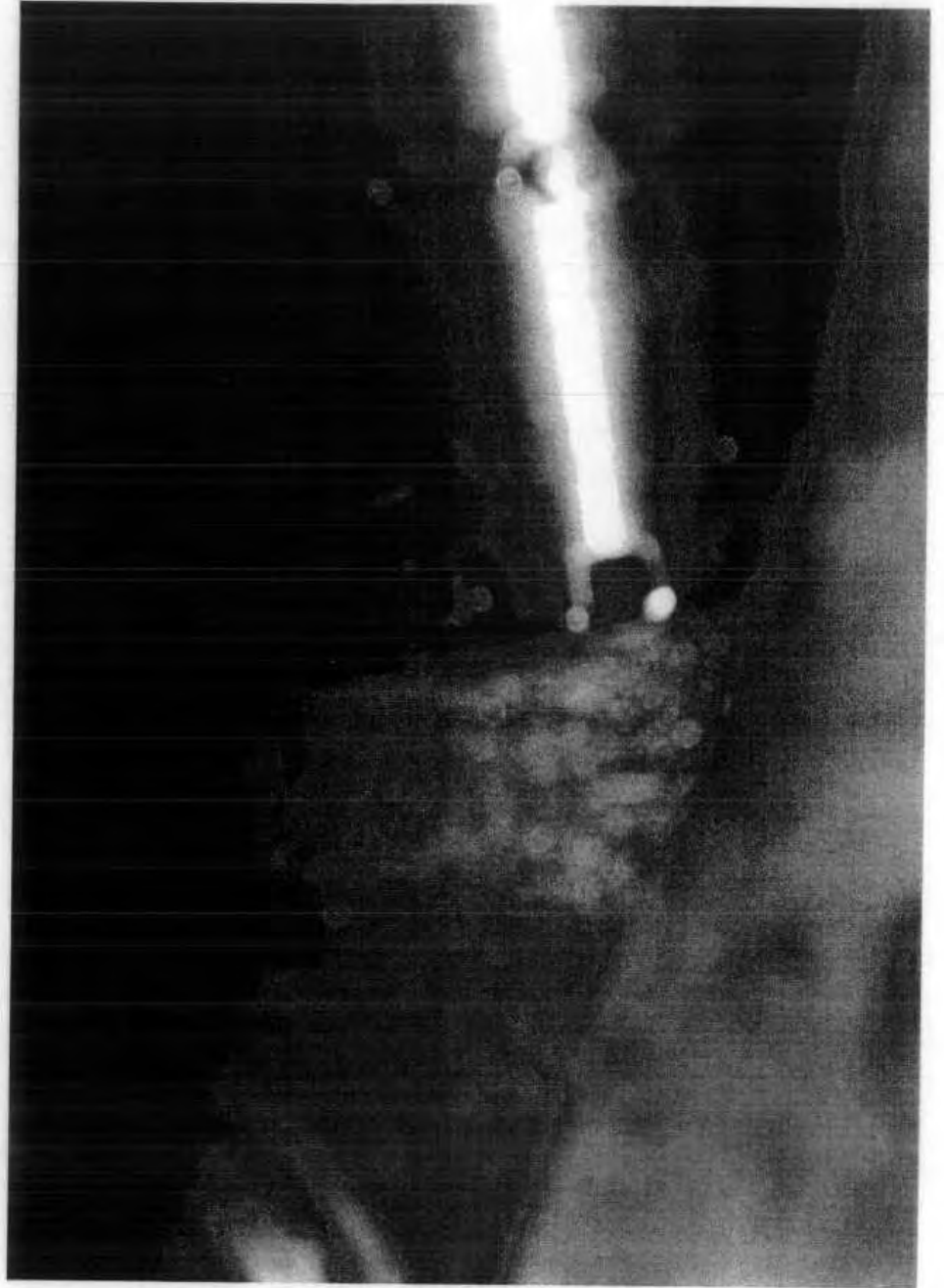
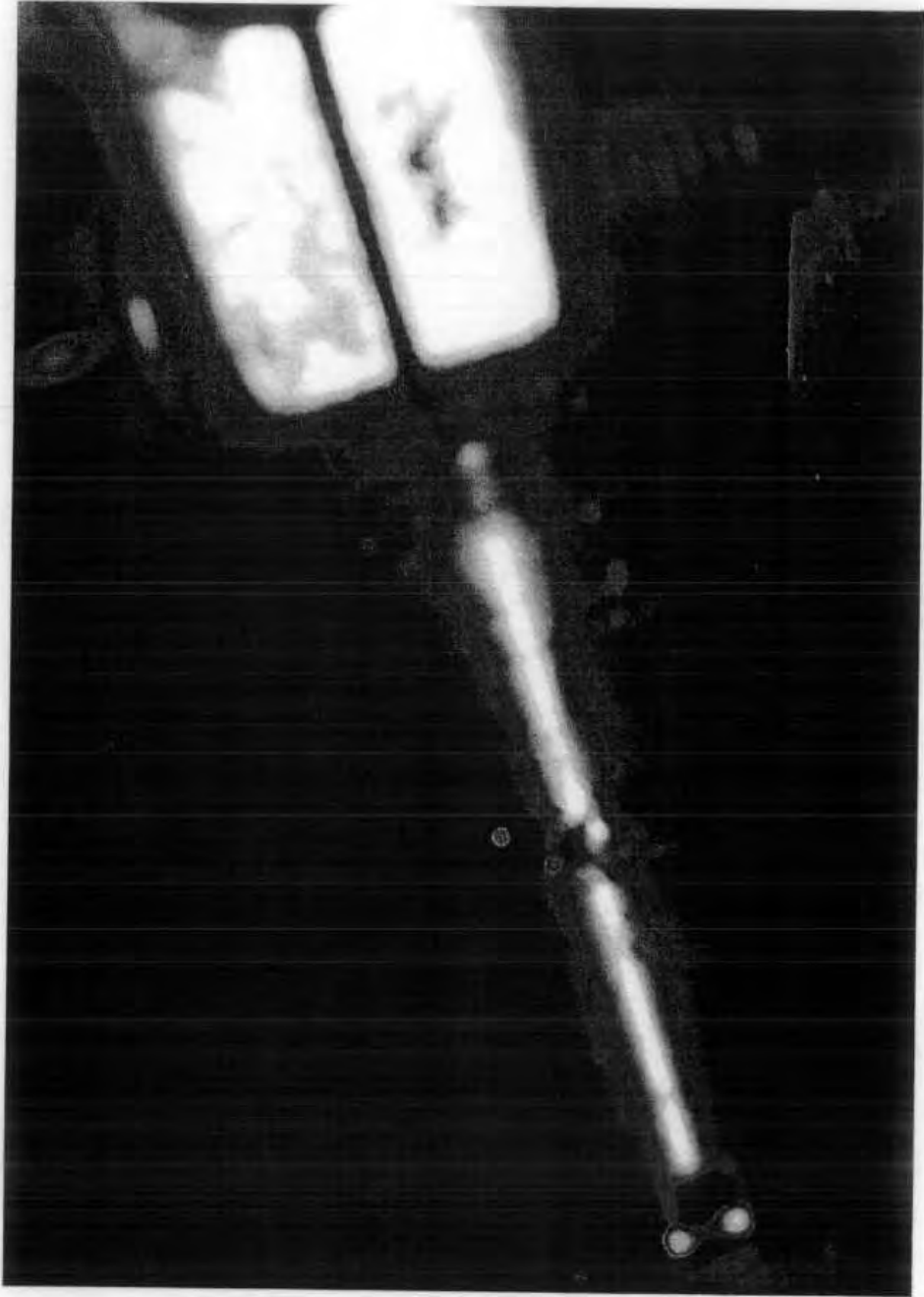

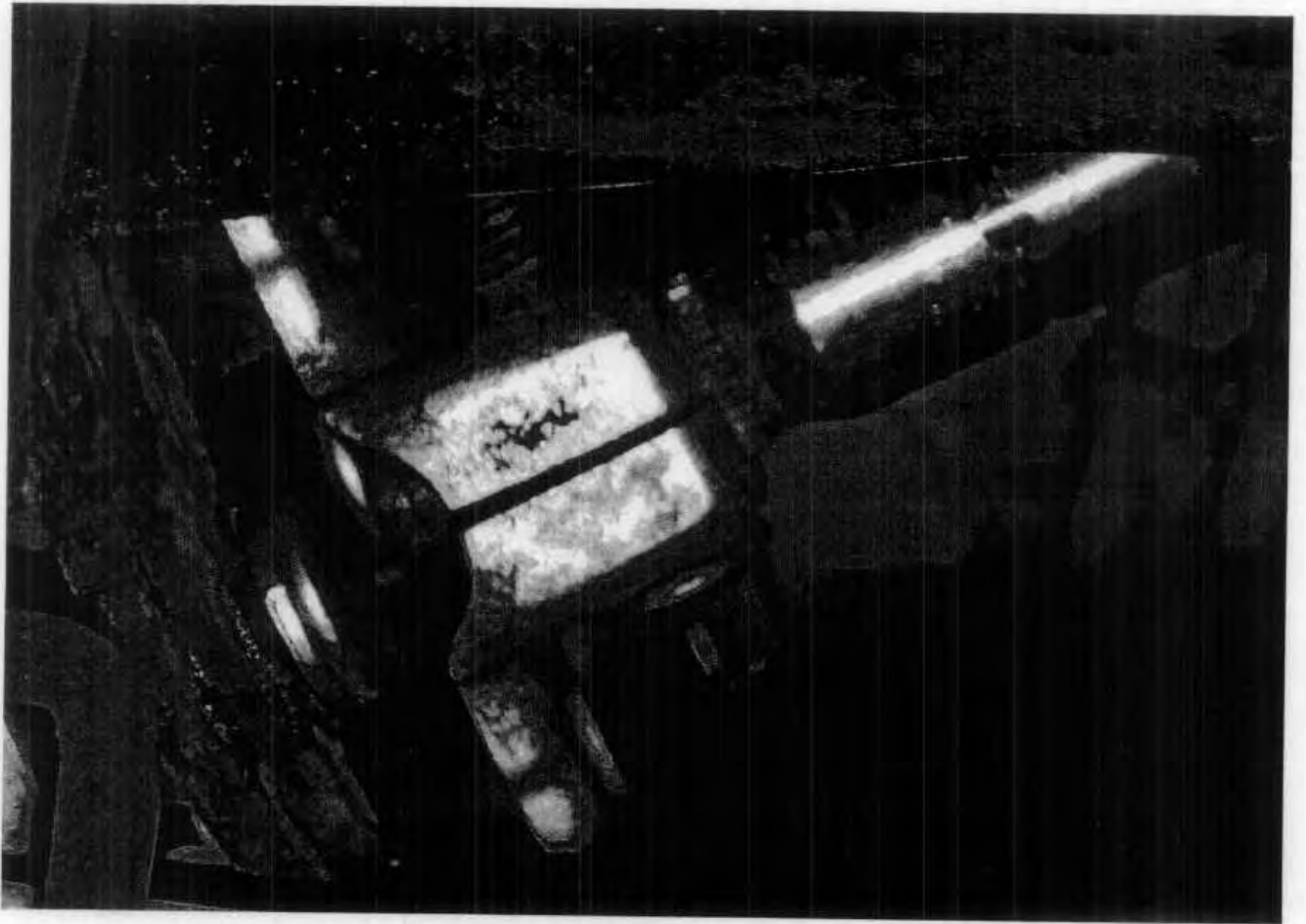
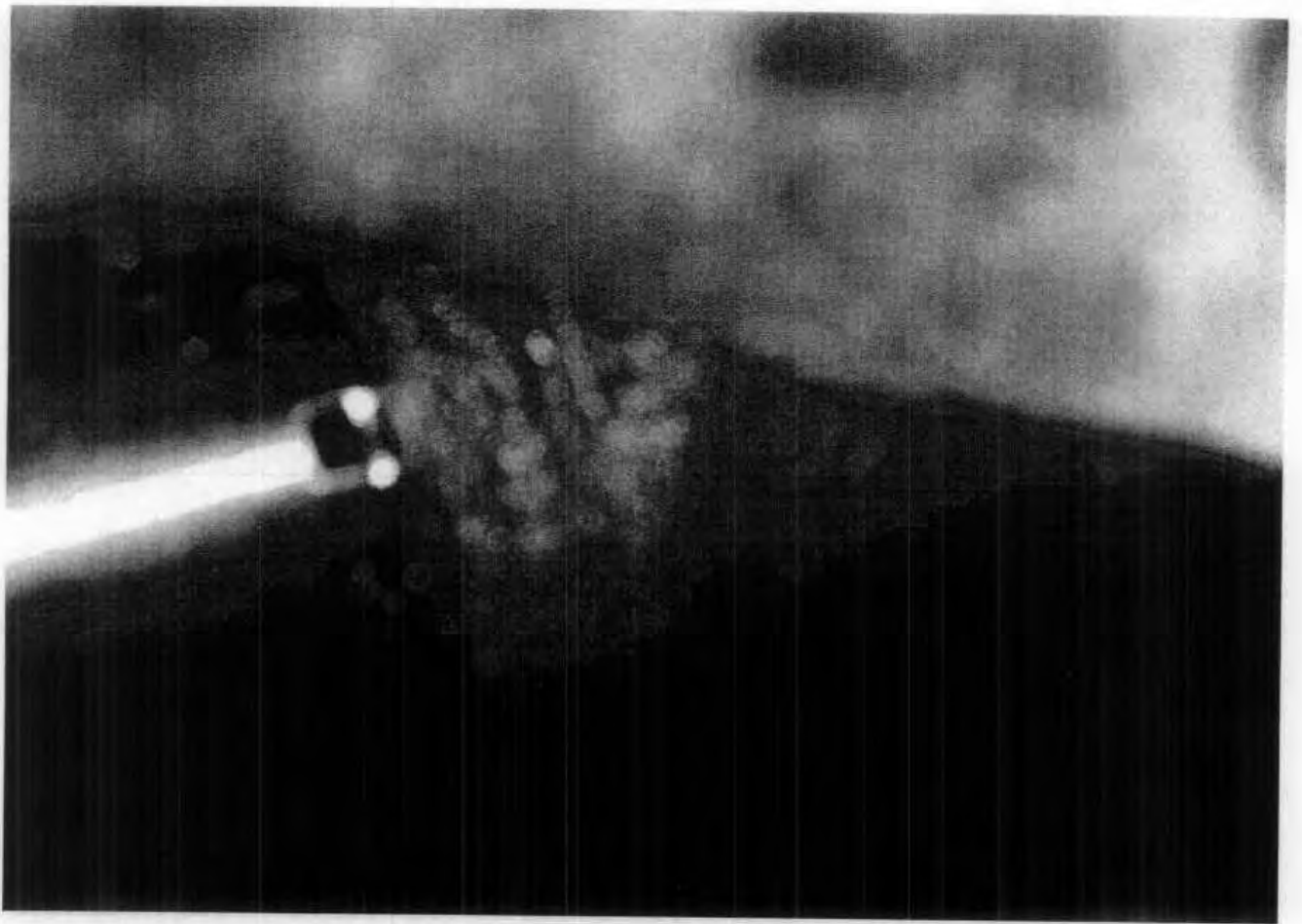





PE13-014

FORD

7/10/2013

Appendix F

Extended Warranty Coverage

**2008 model year Ford F250 and F350
Extended Service Plan Contract Coverage**

**For Base Part Number 3504 (Steering Gear Assembly)
New Contract Counts**

		2008 MY F250 and F350						
Coverage		Plan Years						
Time	Mileage	2006	2007	2009	2010	2011	2012	2013
3 Years	48000	0	0	4	0	0	0	0
	60000	0	0	2	0	1	0	0
	75000	0	0	1	0	0	0	0
	100000	2	309	29	4	0	0	0
4 Years	48000	0	0	0	1	0	0	0
	60000	0	0	3	0	0	0	0
	75000	0	0	1	1	1	0	0
	100000	2	572	44	6	1	0	0
5 Years	36000	0	0	1	1	0	0	0
	48000	0	0	0	1	1	0	0
	60000	0	0	8	3	1	0	0
	75000	0	0	10	6	0	0	0
	100000	16	2244	243	24	3	1	0
	125000	0	0	0	0	2	0	0
6 Years	36000	0	0	1	1	1	0	0
	48000	0	0	0	2	0	0	0
	60000	0	0	10	8	6	1	0
	75000	2	837	86	28	23	4	0
	100000	1	604	80	25	11	1	0
	125000	0	0	0	0	3	0	0
7 Years	36000	0	0	0	0	1	2	0
	48000	0	0	1	2	2	0	0
	60000	0	18	7	4	4	0	0
	75000	0	15	3	10	8	2	4
	100000	0	30	16	23	7	1	1
	125000	0	0	0	0	3	1	0
	150000	0	0	0	0	0	2	1

Used Contract Counts

		2008 MY F250 and F350						
Coverage		Plan Years						
Time	Mileage	2006	2007	2009	2010	2011	2012	2013
6 Months	6000	0	0	1	0	2	1	1
1 Year	12000	0	0	0	1	4	7	6
2 Years	24000	0	1	11	24	64	84	47
	36000	0	0	0	0	0	0	3
3 Years	24000	0	0	0	0	0	13	9
	36000	0	1	12	57	162	161	60
	48000	0	0	0	0	0	82	22
	60000	0	0	0	0	0	0	5
4 Years	36000	0	0	0	0	0	19	10
	48000	0	1	54	145	231	235	46
	60000	0	0	0	0	0	24	4
5 Years	48000	0	0	0	0	0		24
	60000	0	0	0	0	84	72	17
	75000	0	0	0	0	0	0	11

**2008 model year Ford F250 and F350
Extended Service Plan Contract Coverage**

		New Contract Counts						
		2008 MY F250 and F350						
Coverage		Plan Years						
Time	Mileage	2006	2007	2009	2010	2011	2012	2013
3 Years	48000	0	0	3	0	0	0	0
	75000	0	0	1	0	0	0	0
	100000	0	69	24	2	0	0	0
4 Years	48000	0	0	0	1	1	0	0
	60000	0	0	1	0	0	0	0
	75000	0	0	7	0	1	0	0
	100000	1	138	45	12	0	0	0
	125000	0	0	0	0	1	0	0
5 Years	36000	0	0	0	2	2	0	0
	48000	0	0	1	2	0	3	0
	60000	0	0	18	4	5	3	0
	75000	1	375	38	19	10	2	1
	100000	1	623	152	41	10	0	0
	125000	0	0	0	0	1	0	0
6 Years	36000	0	0	0	2	4	1	0
	48000	0	0	3	10	6	1	0
	60000	0	0	24	22	16	7	0
	75000	4	270	94	60	35	5	0
	100000	0	179	97	51	30	3	0
	125000	0	0	0	0	2	0	0
7 Years	36000	0	0	1	1	3	2	0
	48000	0	0	2	3	4	0	0
	60000	0	25	7	17	17	4	0
	75000	0	82	18	13	22	2	4
	100000	0	65	42	72	39	9	0
	125000	0	0	0	0	9	2	1
	150000	0	0	0	0	0	1	0

		Used Contract Counts						
		2008 MY F250 and F350						
Coverage		Plan Years						
Time	Mileage	2006	2007	2009	2010	2011	2012	2013
1 Year	12000	0	0	0	2	3	9	0
2 Years	24000	0	0	7	53	171	290	103
	36000	0	0	0	0	0	0	14
3 Years	24000	0	0	0	0	0	14	15
	36000	0	8	69	135	218	184	161
	48000	0	0	0	0	0	35	11
	60000	0	0	0	0	0	0	11
4 Years	36000	0	0	0	0	0	22	32
	48000	0	3	56	223	263	163	43
	60000	0	0	0	0	0	24	17
5 Years	48000	0	0	0	0	0	0	14
	60000	0	0	0	0	107	71	21
	75000	0	0	0	0	0	0	13

**2008 model year Ford F250 and F350
Extended Service Plan Contract Coverage**

		Used Contract Counts							
		2008 MY F250 and F350							
Coverage		Plan Years							
Time	Mileage	2006	2007	2009	2010	2011	2012	2013	
ROYALSHIELD	2 Months 3000	0	0	2	1	3	0	0	
	3 Months 4000	0	1	13	22	46	77	79	
	6 Months 6000	0	0	0	0	0	18	16	
	1 Year 12000	0	0	0	0	0	32	31	
	2 Years 24000	0	0	0	0	0	0	1	

PE13-014

FORD

7/10/2013

APPENDIX G

Non Conf - Engineering Review

From: Joachim, Jon (B.) <jjoachim@ach-llc.com>
Sent: Thursday, August 07, 2008 10:45 AM
To: Barry, Jack (J.E.)
Cc: Nuler, Kurt (K.W.); Baty, Mark (M.A.)
Subject: RE: RV Gear Housing Casting Resource SREA TC03A-25Jul08

Hi Jack,

Unfortunately (relatively speaking for us engineers) the design changes we proposed for the improved common casting were too costly and greatly increased the overall project timing. This current SREA is a resource of the existing design - only change is a control plan upgrade to the improved casting defect levels vs. Brazil. This "quality" change is BIG in and of itself as we know the struggles with SADA. . . . No print changes and no part number changes. Since there has been no design change, the only FEA work completed is at the Foundry for pattern design & solidification. No structural FEA is necessary because the resulting part is no different from what we have today.

Jon Joachim

Automotive Components Holdings - LLC
Steering Gear Engineering
Phone: 313-755-5762
Fax: 313-755-0866
Cell: 313-550-1478
e-mail: jjoachim@ach-llc.com

From: Barry, Jack (J.E.) [<mailto:jbarry@ford.com>]
Sent: Thursday, August 07, 2008 10:27 AM
To: Eubank, Mark (M.S.); Joachim, Jon (B.)
Cc: Rodgers, David (D.L.)
Subject: RE: RV Gear Housing Casting Resource SREA TC03A-25Jul08

Jon - not sure how much you have been involved in this.....

Are the casting improvements we worked on for the last resourcing part of the assumptions for this?

Also, have you seen the FEA results of this design? Regardless if the changes we worked on before are part of this, it is a different design group now and we will need a new FEA. Hopefully, that has already been started.

Please let me know. Thanks.

Jack Barry

Truck Chassis Steering
Cell Phone ☎: 313-805-0193
Fax 📠: 313-322-0744
Address: PDC 2B662

From: Eubank, Mark (M.S.)
Sent: Tuesday, August 05, 2008 10:05 AM
To: 'jjoachim@ach-llc.com'
Cc: 'Baty, Mark (M.A.)'; Denardis, John (J.); Killins, Dale (D.C.); Rodgers, David (D.L.); Barry, Jack (J.E.); Rawlings, Jeremy (J.A.)
Subject: FW: RV Gear Housing Casting Resource SREA TC03A-25Jul08
Importance: High

Jon,

I see the PV test plan for the housing in the timing plan. Has it been reviewed with Jack Barry? Remember Jacks wish list of design changes when we reviewed a resourcing 6 months ago. Can any of these items be captured with this change?

Will there be a special launch control plan that will have increased samples and frequencies to include X-ray and other porosity checks? When can you review this document with me?

Will the housing pcs price reduction and tooling cost need a Ford concern? This would probably mean a potential part number bump to ensure we track this change but that needs to be discussed. Technically we should not have to pump the part number if it is a tooling transfer only.

The Bldg D functional test stand will be going down for a program upgrade which may impact testing by approximately 6 weeks starting in Aug and may impact your PV testing kick off of 29 Sept.

John Denardis: Need your input on test stand availability starting on 29 Sept.

Ford Motor Company

Mark S. Eubank

Super Duty Truck & Econoline Van

Chassis, Steering Engineer

Certified 6-Sigma Black Belt

Product Development Center, 2B L52, Mail Drop: MD400

20901 Oakwood Blvd, Dearborn, MI. 48124

Mobile Phone: 313-805-0206 Fax: 313-322-0744

meubank@ford.com

ESSAYONS!

From: Baty, Mark (M.A.) [<mailto:mbaty@ach-llc.com>]
Sent: Monday, August 04, 2008 3:31 PM
To: Eubank, Mark (M.S.)
Subject: FW: RV Gear Housing Casting Resource SREA TC03A-25Jul08

Mark, FYI. Here is the summary page and time line that was shared with Dave Rodgers, Brian Bank and Ron Perri on 29-Jul-08 while you were out.

<<RV Gear Casting Resourcing Summary 29Jul08.pdf>> <<RV Gear Casting Resourcing 16Jul08.pdf>>

Mark A. Baty
ACH LLC. - Chassis Program Manager
Office Phone 313-755-1503, Cell 313-410-4674
Fax 313-755-2481 (Please let me know if you fax a document)

From: Baty, Mark (M.A.)
Sent: Friday, July 25, 2008 10:26 AM
To: 'Rodgers, David (D.L.); 'Perri, Ron (R.J.); 'Eubank, Mark (M.S.); 'Co, Helen (H.C.); 'Bank, Brian (B.S.)'
Cc: Whitehead, James (J.B.); 'dhuddl12@ach-llc2.com'; 'josbor73@ach-llc2.com'; Joachim, Jon (B.)
Subject: RV Gear Housing Casting Resource SREA TC03A-25Jul08

Please see attached SREA TC03A-25Jul08 for resourcing RV steering gear housing casting source from Invar suppliers SADA and Tupy to Internet. As you may know, Invar has submitted a cost increase for the current casting sources and ACH has passed this cost increase to Ford Purchasing. This SREA is to off-set these increased costs. Please review and approve this SREA.

<<SREA TC03A-25Jul08.pdf>>

Mark A. Baty
ACH LLC. - Chassis Program Manager
Office Phone 313-755-1503, Cell 313-410-4674
Fax 313-755-2481 (Please let me know if you fax a document)

From: Joachim, Jon (B.) <jjoachim@ach-llc.com>
Sent: Thursday, September 06, 2007 1:45 PM
To: Barry, Jack (J.E.)
Subject: EA Housing Design Proposal Update
Attachments: Phase 2 EA_MOD3.jpeg; Phase 2 EA_MOD1.jpeg; Phase 2 EA_MOD2.jpeg

Importance: High

Hi Jack,

JPEG's attached showing the proposed housing design – I will call to discuss.

Thank you,

Jon Joachim

ACH-LLC Steering Systems

RV Gear Engineering

Phone: 313-755-5762

Fax: 313-755-0866

e-mail: jjoachim@ach-llc.com

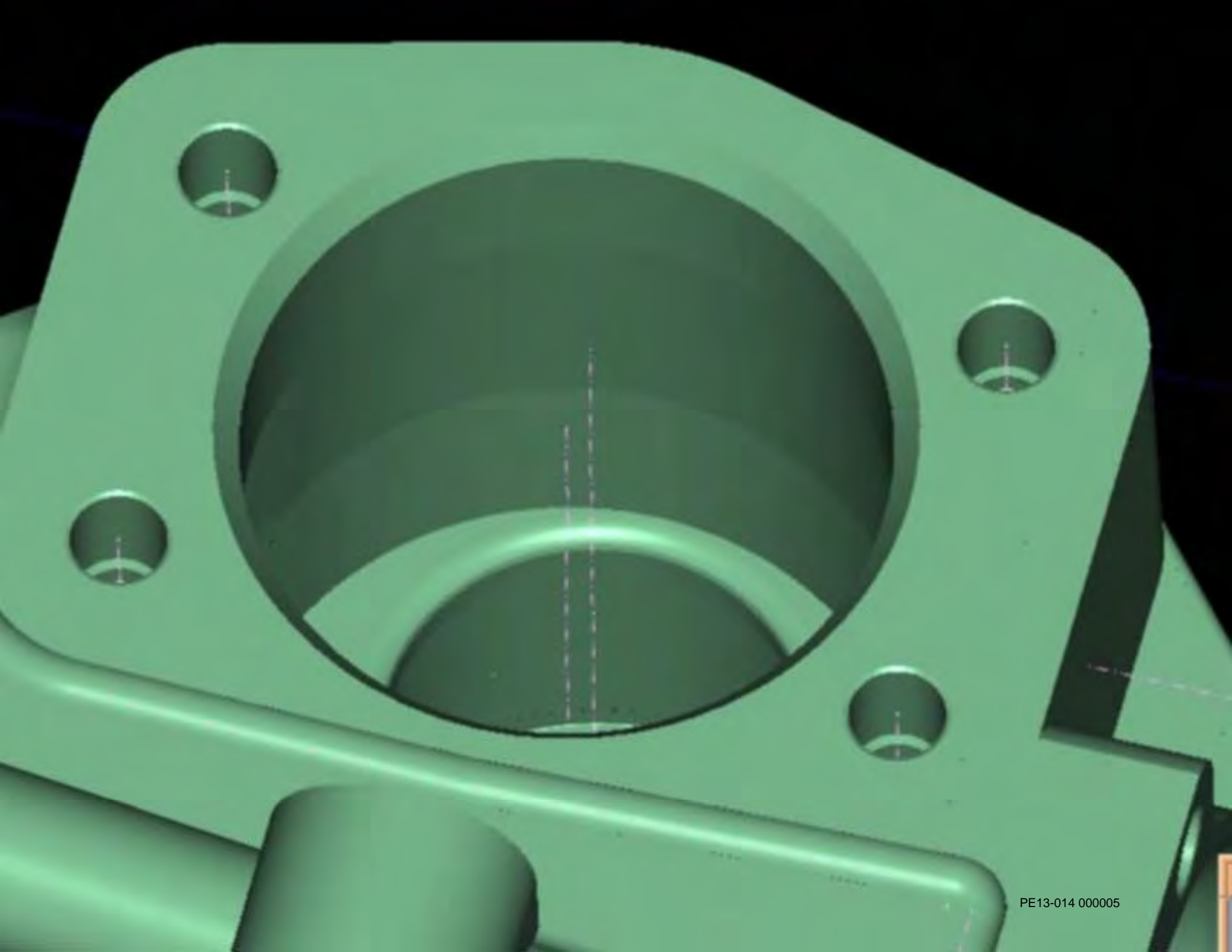

PE13-014 000005

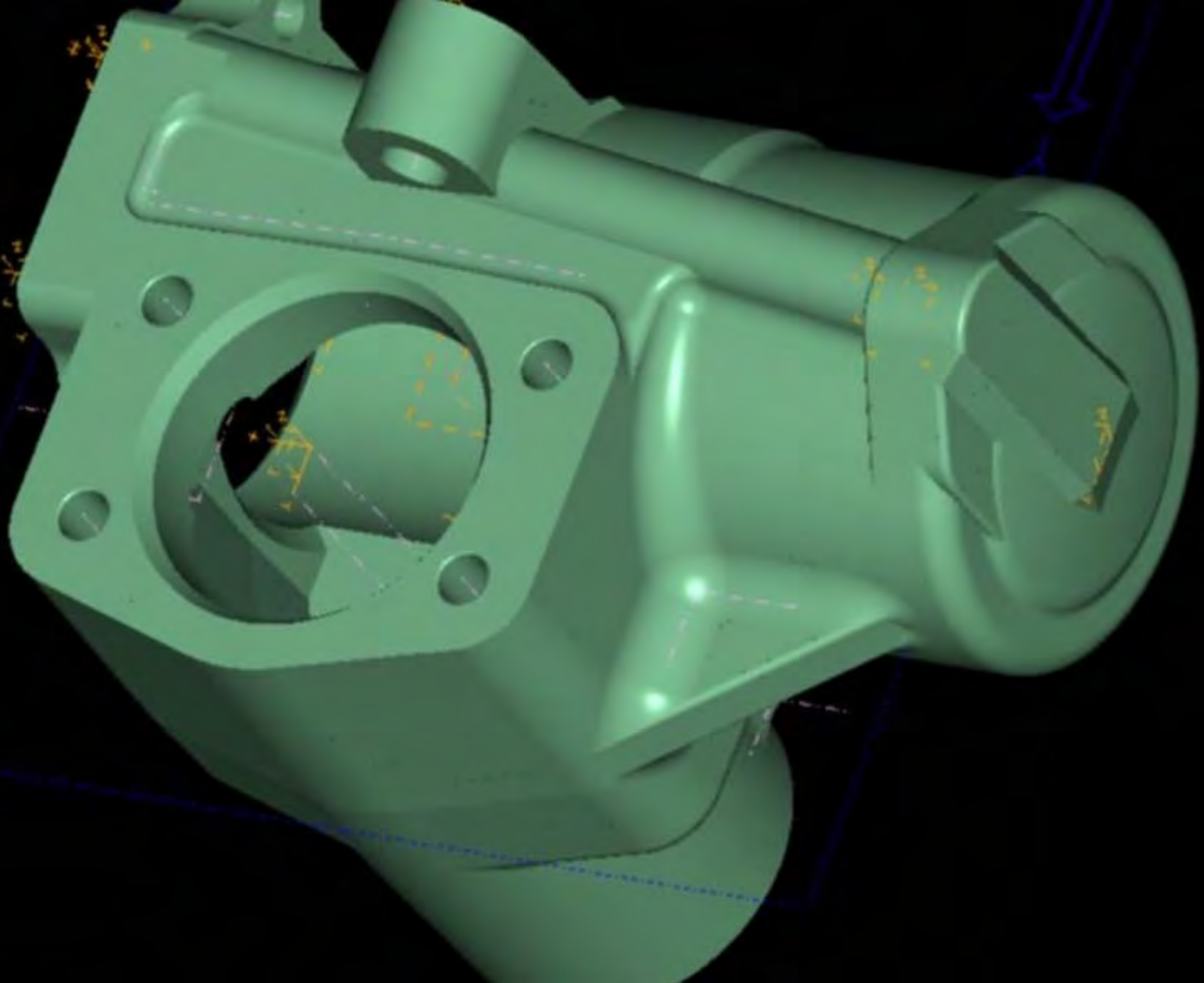

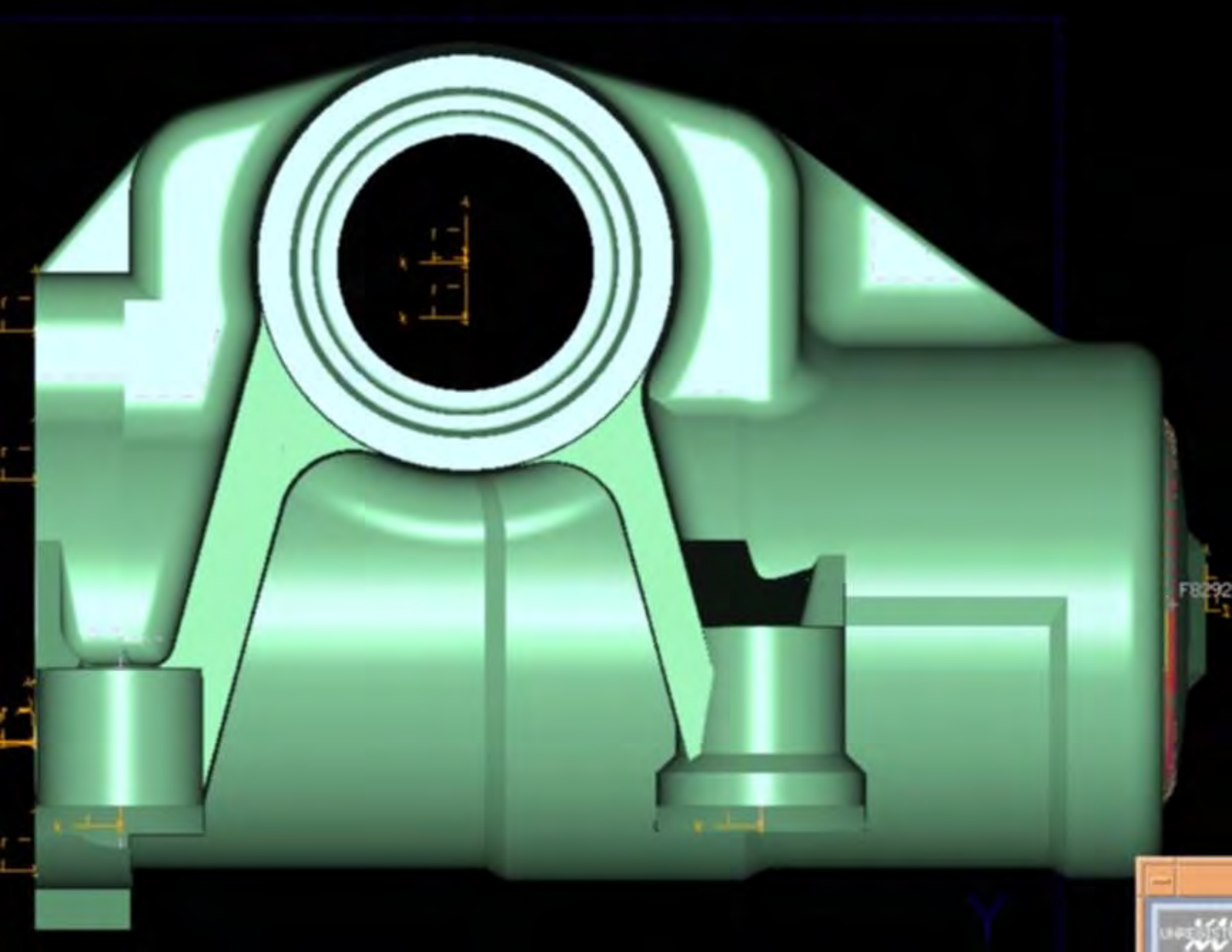

F8292



From: Eubank, Mark (M.S.)
Sent: Thursday, May 14, 2009 12:44 PM
To: Payne, Dan (D.); Joachim, Jon (J.); Nuler, Kurt (K.)
Cc: Baty, Mark (M.A.); Barry, Jack (J.E.); Rodgers, David (D.L.); Peters, Joe (J.J.)
Subject: FEA for HPC failure

Importance: High

Team,

I need the 3D CAD for the new river, Linamar machined gear housing (P356).
Jack and I spoke to our FEA engineer to kick them off on investigating the HPC PV test failure.

We need the most accurate 3D CAD model from new river with machine details from Linamar so this study can be made.

Are there any differences between the new river casting vs the Brazil casting? I am sure there are some changes due to casting/tooling methods etc.

As this failure occurs at the same bolt head next to the gear to frame bolt location it is suspected that a bowing/rocking motion is leveraging the bolt head to the shear point.

As you know we can not move to this new housing until we resolve this failure issue.

I understand Brazil castings are being shipped instead of air freight so I guess that is a sign of the logistics getting better. Worst Case: If this becomes a major issue can we get P356 gear housings from SA until the program ends?

Please send CAD models to Joe Peters in the CC above.

Thanks

Ford Motor Company

Mark S. Eubank

Super Duty Truck & Econoline Van

Chassis, Steering Engineer

Certified 6-Sigma Black Belt

Product Development Center, 2B L52, Mail Drop: MD400

20901 Oakwood Blvd, Dearborn, MI. 48124

Mobile Phone: 313-805-0206 Fax: 313-322-0744

meubank@ford.com

ESSAYONS!

From: Eubank, Mark (M.S.)
Sent: Friday, June 05, 2009 1:46 PM
To: Loeffler, James (J.F.)
Cc: Barry, Jack (J.E.); Rodgers, David (D.L.)
Subject: FW: RV Gear EA Housing Porosity Issue
Attachments: 100_2733.JPG; 100_2731.JPG

Jim,

Could you review this with me?
ACH is wanting to use these housings which have porosity concerns.
Wanted your recommendations before we accept anything.

Ford Motor Company

Mark S. Eubank

Super Duty Truck & Econoline Van

Chassis, Steering Engineer

Certified 6-Sigma Black Belt

Product Development Center, 2B L52, Mail Drop: MD400

20901 Oakwood Blvd, Dearborn, MI. 48124

Mobile Phone: 313-805-0206 Fax: 313-322-0744

meubank@ford.com

ESSAYONS!

From: Nuler, Kurt (K.W.) [<mailto:knuler@ach-llc.com>]

Sent: Friday, June 05, 2009 9:19 AM

To: Eubank, Mark (M.S.)

Cc: Joachim, Jon (J.); Baty, Mark (M.A.); Whitehead, James (J.B.); Chaney, Robert (R.L.); Spala, Kevin (K.P.); Rodgers, David (D.L.); Osborn, Jeffrey (J.A.)

Subject: FW: RV Gear EA Housing Porosity Issue

Mark,

ACH has been struggling with supply of EA RV gear housings from Linamar. Linamar machined housings with porosity in bottom of the valve bolt hole (see pictures attached) and these parts have been quarantined. Due to the RV gear EA supply issues there is a desire to determine if any of these quarantined parts can be used. Bob Chaney is getting X-rays for 60 of these parts to determine if the porosity location is consistent of if there is any risk that it gets into the piston bore. Bob will be sending this information to you on Monday once this info is complete. Please work with Indy to determine if any of these parts can be used and what testing is needed (if any) to determine this. Thanks.

Regards/Mit freundlichen Grüßen

Kurt W. Nuler

Manager Core Steering Gear PD & Prgm Mngr TQCM

Office: ACH-HQ, 2nd floor, Office #: C235-30

Phone: **(313) 755-1580** Cell: (313) 549-4644

e-mail: knuler@ach-llc.com

From: Al Wilkinson [<mailto:Al.Wilkinson@Linamar.com>]
Sent: Tuesday, May 19, 2009 4:03 PM
To: Joachim, Jon (B); Chaney, Robert (R.L.)
Cc: Spala, Kevin (K.P.); Willi Jasbar; John Graham; Nuler, Kurt (K.W.)
Subject: FW: Porosity

Jon / Bob,

We are finding porosity in the 3/8-16 bolt hole on the front frame pad of the 5C3C-3550-EA Steering Housings. I have attached two photos where we milled away the material to expose the thread and make the porosity more viewable. The porosity is small in nature (approx .040" - .050" in dia) and is located on or about the 9th thread in the threaded hole. I have had several of the parts leak tested and all passed with no issues. This is current material we just received in from SADA. At this point I don't know how many date codes will be affected.

Take a look and let me know if you feel these parts are acceptable.

Thanks,

Al Wilkinson
Program Mgr
INVAR Manufacturing Corp.
1 Parry Drive
Batawa, Ontario, Canada, K0K 1E0
Tel: 613 398 6106
Fax: 613 398 6029
email: al.wilkinson@linamar.com
linamar.com



ENERGY GROUP

The information transmitted is intended only for the person or entity to which it is addressed and may contain confidential and/or privileged material. Any review, retransmission, dissemination or other use of, or taking of any action in reliance upon, this information by persons or entities other than the intended recipient is prohibited. If you received this in error, please contact the sender and delete the material from any computer.

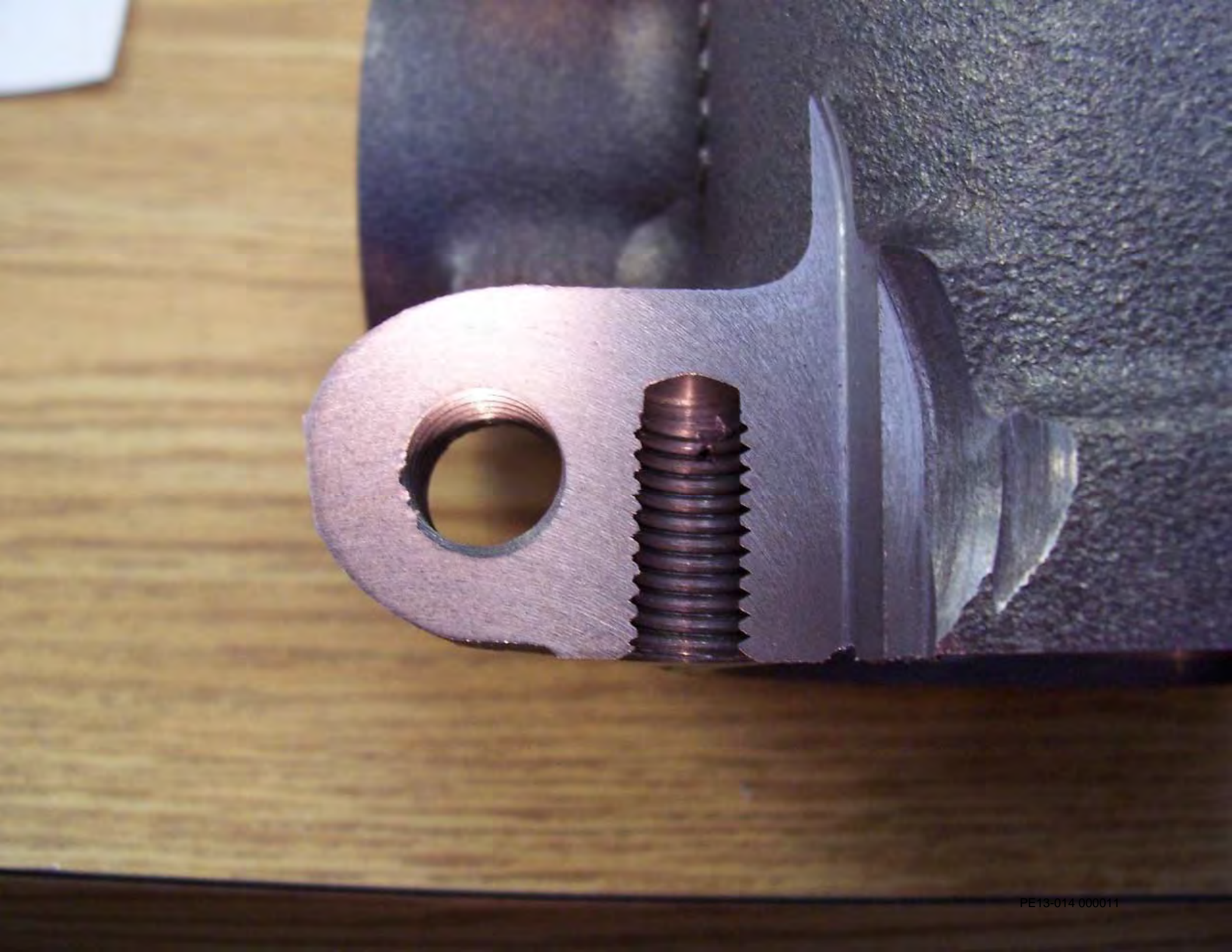

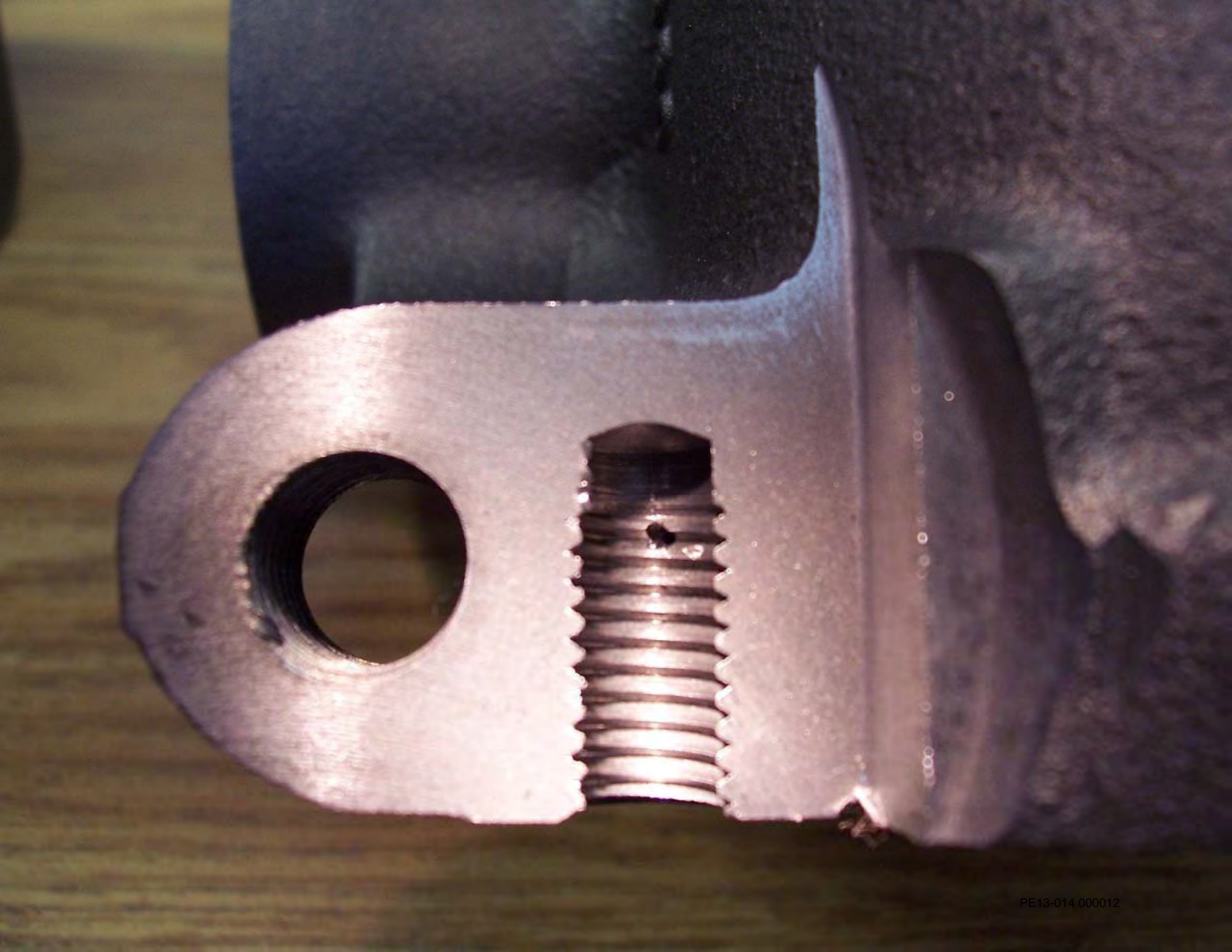

From: Huddleston, David (D.A.) <dhuddles@ach-llc.com>
Sent: Tuesday, June 19, 2007 8:31 AM
To: Boals, Shannon (S.D.); Barry, Jack (J.E.)
Subject: FW: Notes from Meeting with Ford PD/STA on Invar

For post x-ray validation, we propose to burst test one sample from each pour date we intend to use.

We are compiling the dimensional checking plan and Mark is trying to set up a review later today.

David Huddleston

Senior Manager, Steering Gear Product Development
Automotive Components Holdings, LLC
Phone: 313 755-4374 Fax: 313 755-0422
email: dhuddles@ach-llc.com

-----Original Message-----

From: Boals, Shannon (S.D.) [mailto:sboals1@ford.com]
Sent: Sunday, June 17, 2007 9:45 PM
To: Co, Helen (H.C.); Balthazar, John (J.F.); Barry, Jack (J.E.); Do, Son (V.); Loeffler, Jim (J.F.); Kruse, Alan (A.P.); Combs, Keith (K.W.); White, Isiah (I.C.)
Cc: Huddleston, David (D.A.); Andrade, Ron (R.A.); Johnston, Lia (L.S.); Beshears, Jill (J.)
Subject: RE: Notes from Meeting with Ford PD/STA on Invar

Team,

As Dave Huddleston's's note stated, I have not signed an SREA. I have not approved the testing plan that has been proposed since there is no mention of high pressure testing nor did I see the list of final checks. When Jack Barry gets back from the various Linemar site reivews that are going on this week, I will need him and STA to review the dimensional checks and the x-ray checks prior to the testing the entire warehouse. We also need to get resolution on the burst test.

Shannon Boals

Steering Gear Manager
Ford North America Chassis Engineering
Office: PDC Room 2B-J80
Phone/Fax: (313) 390-5163
Email: <<mailto:sboals1@ford.com>>

From: Co, Helen (H.C.)
Sent: Friday, June 15, 2007 5:26 AM
To: Boals, Shannon (S.D.); Balthazar, John (J.F.); Barry, Jack (J.E.); Do, Son (V.)
Subject: FW: Notes from Meeting with Ford PD/STA on Invar

FYI...

From: Loeffler, Jim (J.F.)
Sent: Thursday, June 14, 2007 3:32 PM
To: White, Isiah (I.C.); Co, Helen (H.C.)
Subject: RE: Notes from Meeting with Ford PD/STA on Invar

Mickey and Helen,

I received a call from Bob Chaney of ACH today (6/14). ACH is anxious to begin processing the WHB Warehouse machined castings due to the short supply of RV Gear housings from the Invar machining process. He did not have the inventory status at ACH Indy but mentioned it was very limited inventory.

ACH is wanting to start with 500 pieces sample (of the intended 5000pc) going through a process flow of:

- WHB Warehouse (preliminary dimensional gaging) > USI Inspection for Xray (piston bore/gate area views) > Invar for end of line 'autogage' (between downtime on the cell) > ACH Indy (final assembly)

Bob has forwarded information from the WHB inspection plan and the USI inspection work instructions with an x-ray image of a suspect cold shut part. In the JPEG image provided the cold shut is visible (the actual x-ray image is much better than JPEG).

I'm writing to give you a heads up that ACH is moving forward with a sample lot from the WHB Warehouse inventory to verify the product through the defined inspection plan.

I expressed to Bob Chaney the need for approval by Ford PD and STA to ship the product to a Ford Assembly Plant. He said the SREA submission is on the way soon.

Regards,

Jim Loeffler

Casting Technical Versatilist

Ford Chassis STA

Phone: 313-805-2392 Fax: 313-390-0793

Text Message <http://messaging.sprintpcs.com> (3138052392)

E-mail: jloeffl1@ford.com

"The information contained herein is FORD PROPRIETARY information and may include FORD CONFIDENTIAL information as defined in Ford's Global Information Standard II. Reproduction of this document, disclosure of the information, and use for any purpose other than the conduct of business with Ford is expressly prohibited"

From: Co, Helen (H.C.)
Sent: Tuesday, June 12, 2007 3:42 PM
To: Loeffler, Jim (J.F.)
Subject: FW: Notes from Meeting with Ford PD/STA on Invar
Importance: High

From: Combs, Keith (K.W.) [<mailto:kcombs@ach-llc.com>]
Sent: Tuesday, June 12, 2007 3:06 PM
To: King, Thomas (T.C.); Chaney, Robert (R.L.)
Cc: Co, Helen (H.C.)
Subject: FW: Notes from Meeting with Ford PD/STA on Invar
Importance: High

Tom/Bob,

Please see attached notes from the meeting with Ford yesterday regarding the validation/sort of New Hubner castings. Apparently, Ford is asking to review the inspection criteria for the nick issue at New Hubner - but I thought that Ford STA had committed to reviewing the control plans for both USI (X-Ray) and New Hubner last week...did this not happen?

Bob - please provide status on Gage R&R for the New Hubner sort. Are they up and sorting this week? Did we finish/approve the Control Plan?

Tom - did we overlay the Invar autogage against the four "unchecked" functional characteristics? If so, we need to line up a quantity of EA parts - 5,000 to be safe - sorted by New Hubner and X-Ray complete - waiting at Invar in case their line goes down (as it was this morning) and they can run them through the autogage.

Keith Combs

kcombs@ach-llc.com

(313)-755-2803; (313)402-4109 (mobile)

From: Andrade, Ron (R.A.)
Sent: Tuesday, June 12, 2007 10:37 AM
To: Huddleston, David (D.A.); Combs, Keith (K.W.); Squires, Kelvin (K.B.)
Cc: Beshears, Jill (J.); Johnston, Lia (L.S.); Baty, Mark (M.A.); Bicking, Kevin (K.)
Subject: RE: Notes from Meeting with Ford PD/STA on Invar

We briefly discussed P356 leak "warranty spike". Data they used was same we have. Different interpretations of what a "spike" looks like.--Ron

R. A. Andrade

Director

Powertrain/Chassis Product Engineering

Automotive Components Holdings LLC

ACH Headquarters C2B

313-755-2327

randrade@ach-llc.com

-----Original Message-----

From: Huddleston, David (D.A.)
Sent: Tuesday, June 12, 2007 10:32 AM
To: Combs, Keith (K.W.); Squires, Kelvin (K.B.)
Cc: Andrade, Ron (R.A.); Beshears, Jill (J.); Johnston, Lia (L.S.); Baty, Mark (M.A.)
Subject: Notes from Meeting with Ford PD/STA on Invar

We had a very productive meeting with Ford PD on the status of Invar supply and the potential containment plan for using the New Hubner warehouse parts. Ford participants included Shannon Boals, Jack Barry, Mickey White, Helen Co and Jim Loeffler.

The main points of discussion concerned the validation of the New Huebner parts:

Nick/Scratch: Ford requested an on-site review of the visual sort process and proposed running some rabbits through the sort process to ensure we would catch them. They also discussed post-inspection testing to validate the process, but there was no final decision.

Cold Shut: Again, the discussion was around post-inspection validation. We considered a test plan using burst test, but again no final decision.

Porosity: General agreement that the 100% x-ray would cover this.

Dimensional: As expected, the New Hubner capability data raised concern. We didn't spend much time on the detail, but Ford clearly wants to go through the full inspection/gaging/Indy capability plan.

Our expectation is that Ford will digest the data and proposals and we would reconvene in a few days to discuss further requirements or conditions for the use of the parts.

Other ACH participants, please feel free to add other observations or detail.

David Huddleston

Senior Manager, Steering Gear Product Development

Automotive Components Holdings, LLC

Phone: 313 755-4374 Fax: 313 755-0422

email: dhuddles@ach-llc.com

From: Payne, Dan (D.) <dpayne12@ach-llc.com>
Sent: Monday, June 02, 2008 3:06 PM
To: Barry, Jack (J.E.)
Subject: RE: P356 Sector stake nut broken
Attachments: 5C3C-3575-AD.tiff

Jack,

Sector shaft drawing attached.

Dan Payne

*Product Design Engineer, Steering Systems
Automotive Components Holdings, LLC*
ph: 313-755-5783
fax: 313-755-5087
dpayne12@ach-llc.com

CONFIDENTIALITY NOTICE: This e-mail message including attachments, if any, is intended only for the person or entity to which it is addressed and may contain confidential and /or privileged material. Any unauthorized review, use, disclosure or distribution is prohibited. If you are not the intended recipient, please contact the sender by reply e-mail and destroy all copies of the original message. If you are the intended recipient but do not wish to receive communications through this medium, please so advise the sender immediately.

From: Barry, Jack (J.E.) [<mailto:jbarry@ford.com>]
Sent: Monday, June 02, 2008 2:52 PM
To: Payne, Dan (D.)
Subject: RE: P356 Sector stake nut broken

Sorry Dan, but I need another one, too.

Can I get the sector shaft drawing from you?

Thx.

Jack Barry

Truck Chassis Steering
Cell Phone ☎: 313-805-0193
Fax 📠: 313-322-0744
Address: PDC 2B662

From: Payne, Dan (D.) [<mailto:dpayne12@ach-llc.com>]
Sent: Monday, June 02, 2008 1:48 PM
To: Barry, Jack (J.E.)
Cc: Annadi, Hari (H.)
Subject: RE: P356 Sector stake nut broken

Jack,

Here you go.

Dan Payne

*Product Design Engineer, Steering Systems
Automotive Components Holdings, LLC
ph: 313-755-5783
fax: 313-755-5087
dpayne12@ach-llc.com*

CONFIDENTIALITY NOTICE: This e-mail message including attachments, if any, is intended only for the person or entity to which it is addressed and may contain confidential and /or privileged material. Any unauthorized review, use, disclosure or distribution is prohibited. If you are not the intended recipient, please contact the sender by reply e-mail and destroy all copies of the original message. If you are the intended recipient but do not wish to receive communications through this medium, please so advise the sender immediately.

From: Barry, Jack (J.E.) [<mailto:jbarry@ford.com>]
Sent: Monday, June 02, 2008 12:23 PM
To: Payne, Dan (D.)
Cc: Annadi, Hari (H.)
Subject: RE: P356 Sector stake nut broken

Dan - can you send me the drawings for the current P356 sector cover and bearing?

Thanks!

Jack Barry

Truck Chassis Steering
Cell Phone ☎: 313-805-0193
Fax 📠: 313-322-0744
Address: PDC 2B662

From: Barry, Jack (J.E.)
Sent: Wednesday, May 28, 2008 4:36 PM
To: Annadi, Hari (H.); Perri, Ron (R.J.); Rodgers, David (D.L.); Rawlings, Jeremy (J.A.); Eubank, Mark (M.S.)
Cc: Garrett, Scott (S.A.); 'Whitehead, James (J.B.); 'Osborn, Jeffrey (J.A.)'
Subject: RE: P356 Sector stake nut broken

I blocked some time out on the next two Mondays to start all of the stack-ups for this design. I think that I can get it done by then as long as I can keep these windows free.

Jack Barry

Truck Chassis Steering
Cell Phone ☎: 313-805-0193
Fax 📠: 313-322-0744
Address: PDC 2B662

From: Annadi, Hari (H.)
Sent: Wednesday, May 28, 2008 3:33 PM
To: Barry, Jack (J.E.); Perri, Ron (R.J.); Rodgers, David (D.L.); Rawlings, Jeremy (J.A.); Eubank, Mark (M.S.)
Cc: Garrett, Scott (S.A.); 'Whitehead, James (J.B.)'; 'Osborn, Jeffrey (J.A.)'
Subject: P356 Sector stake nut broken

Jack - Like I mentioned earlier, this failure contributes to 7% of the returns. Can you pl prioritze the mark up of the drawings for the revised design so we can ask ACH for a cost study for implementation. Thanks.

Hari Annadi

Chassis Master Black Belt

Steering VFG Lead

Building # PDC 2B-A78

Work Cell: 313 805 4746

Ford Motor Company, Dearborn, Michigan

email: hannadi@ford.com <<mailto:hannadi@ford.com>>

From: Garrett, Scott (S.A.)
Sent: Friday, June 29, 2007 5:25 PM
To: Baty, Mark (M.A.); Barry, Jack (J.E.); Seufert, David (D.C.)
Cc: Boals, Shannon (S.D.); Johnston, Lia (L.S.); Beshears, Jill (J.); Osborn, Jeffrey (J.A.); Schutz, Theresa (T.L.); Scifres, Sandra (S.L.)
Subject: RE: Trial run

Yes, and additionally we will complete the additional 101 gear trial on Monday or Tuesday after shutdown.

From: Baty, Mark (M.A.) [<mailto:mbaty@ach-llc.com>]
Sent: Fri 6/29/2007 3:11 PM
To: Barry, Jack (J.E.); Seufert, David (D.C.); Garrett, Scott (S.A.)
Cc: Boals, Shannon (S.D.); Johnston, Lia (L.S.); Beshears, Jill (J.); Osborn, Jeffrey (J.A.); Schutz, Theresa (T.L.); Scifres, Sandra (S.L.)
Subject: RE: Trial run

Scott, Can we assume from your note that you are saying the functional trial for the Ariss housing SREA action is OK without issue based on the three units run? Please confirm. Thanks.

Mark A. Baty
ACH LLC. - Chassis Program Manager
Office Phone 313-755-1503, Cell 313-410-4674
Fax 313-755-2481 (Please let me know if you fax a document)

-----Original Message-----

From: Barry, Jack (J.E.) [<mailto:jbarry@ford.com>]
Sent: Friday, June 29, 2007 2:58 PM
To: Seufert, David (D.C.); Garrett, Scott (S.A.); Baty, Mark (M.A.); Baty, Mark (M.A.)
Cc: Boals, Shannon (S.D.)
Subject: RE: Trial run

Thanks, Dave and Scott!!!

Mark - you should be good to go.

Jack Barry

Truck Chassis Steering
Cell Phone ☎: **313-805-0193**
Fax 📠: **313-322-0744**
Address: **PDC 2BK43**

From: Seufert, David (D.C.)
Sent: Friday, June 29, 2007 2:33 PM
To: Boals, Shannon (S.D.); Garrett, Scott (S.A.); Barry, Jack (J.E.)
Subject: RE: Trial run

Shannon/Scott/Jack: I evaluated 3 of the 4 vehicles (8E [REDACTED], 8E [REDACTED], 8E [REDACTED]). I evaluated them for steering efforts, noise, and clear vision. I also looked for leaks. No issues on any of the three vehicles.

From: Boals, Shannon (S.D.)
Sent: Friday, June 29, 2007 1:22 PM
To: Garrett, Scott (S.A.); Barry, Jack (J.E.)
Cc: Seufert, David (D.C.)
Subject: RE: Trial run

Thanks!

Shannon Boals

Steering Gear Manager
Ford North America Chassis Engineering
Office: PDC Room 2B-J80
Phone/Fax: (313) 390-5163
Email: <<mailto:sboals1@ford.com>>

From: Garrett, Scott (S.A.)
Sent: Friday, June 29, 2007 11:25 AM
To: Boals, Shannon (S.D.); Barry, Jack (J.E.)
Cc: Seufert, David (D.C.)
Subject: Trial run

We have decided to run a limited trial of 4 gears so we can evaluate the vehicles with a maximum of 4 vehicles requiring rework if all goes bad. The line is up and running so I would expect the vehicles to come off the line at 4:00 or so.

Dave, please e-mail all with results from the evaluation. Thanks

Scott Garrett
Chassis Steering D&R
Ph (313) 805-5956
e-mail:sgarre16@ford.com

ZF 5200 pc Service Issues

	F350 FB	F450/550
2008 Release	<div style="border: 1px solid black; background-color: #cccccc; padding: 5px; width: fit-content; margin-bottom: 5px;">Gear B</div> <div style="border: 1px solid black; background-color: #90ee90; padding: 5px; width: fit-content; margin-left: 100px;">Pitman Arm D</div>	<div style="border: 1px solid black; background-color: #cccccc; padding: 5px; width: fit-content; margin-bottom: 5px;">Gear B</div> <div style="border: 1px solid black; background-color: #00bfff; padding: 5px; width: fit-content; margin-left: 100px;">Pitman Arm C</div>
5200 pc Interim Plan	<div style="border: 1px solid black; background-color: #cccccc; padding: 5px; width: fit-content; margin-bottom: 5px;">Gear B</div> <div style="border: 1px solid black; background-color: #90ee90; padding: 5px; width: fit-content; margin-left: 100px;">Pitman Arm D</div>	<div style="border: 1px solid black; background-color: #ffcc99; padding: 5px; width: fit-content; margin-bottom: 5px;">Gear X</div> <div style="border: 1px solid black; background-color: #ffff99; padding: 5px; width: fit-content; margin-left: 100px;">Pitman Arm Y</div>

- Gears B and X are not interchangeable unless accompanied w/ mating pitman arms.
- Pitman Arm Y is not interchangeable with Pitman Arms C & D.
- Concerns:
 - Minor issue – Gear X is serviced by Gear B, which forces a pitman arm change from Y to C (relatively small \$).
 - **Major issue – Pitman Arm Y is serviced by Pitman Arm C which forces a gear change from X to B (big \$\$\$).**
 - Pitman arm only warranty is very low – estimated at ~ 5 pcs/yr.

PE13-014

FORD

7/10/2013

Appendix I

Part Change Log

2005-2009 F250/F350 Loss of Steering

Part Name	A	B	C	D	E	F		G	H
	Date Part Incorporated into Vehicle Production	Description of Change	Reasons for Change	Original	Modified	Disposition of Original Parts		New Component Availability Date For Service	New Component Interchangeable With Old (Y/N)
				Ford Engineering and Service Part Numbers	Ford Engineering and Service Part Numbers	Withdrawn from Ford Production Inventory (Scrap/ Consume/ Rework)	Effective Date		
1) Steering Gear Assembly									
GEAR ASY - STEERING	July 19, 2004 (Job #1 2005 MY)	Start of Production	Start of Production	N/A	5C34-3504-AH (Engr) 5C3Z-3504-AA (Serv)	N/A	July 19, 2004	July 19, 2004	N/A
GEAR ASY - STEERING	May 16, 2005 (Job 1 2006 MY)	N/A	N/A	N/A	N/A	N/A	N/A	N/A	N/A
GEAR ASY - STEERING	May 30, 2005	Square cut set and port/chamfer machining	Address Potential Seal Leaks	5C34-3504-AH (Engr) 5C3Z-3504-AA (Serv)	5C34-3504-AJ (Engr) 5C3Z-3504-AA (Serv)	C	May 30, 2005	May 30, 2005	Y
GEAR ASY - STEERING	February 16, 2006	Revised supplier process for test equipment	Mesh Load Set	5C34-3504-AJ (Engr) 5C3Z-3504-AA (Serv)	6C34-3504-AA (Engr) 6C3Z-3504-A (Serv)	C	February 16, 2006	February 16, 2006	Y
GEAR ASY - STEERING	May 15, 2006 (Job 1 2007 MY)	New test equipment at supplier	Mesh Load Set	6C34-3504-AA (Engr) 6C3Z-3504-A (Serv)	6C34-3504-AB (Engr) 6C3Z-3504-AB (Serv)	C	May 15, 2006	May 15, 2006	Y
GEAR ASY - STEERING	September 21, 2006	Boost Curve Change	Boost Curve Tuning	6C34-3504-AB (Engr) 6C3Z-3504-AB (Serv)	7C34-3504-AB (Engr) 7C3Z-3504-A (Serv)	C	September 21, 2006	September 21, 2006	Y
GEAR ASY - STEERING	December 19, 2006 (Job 1 2008 MY)	Boost Curve Change - Unique boost curve for diesel application	Boost Curve Tuning	7C34-3504-AB (Engr) 7C3Z-3504-A (Serv)	7C34-3504-AB (Engr) Gas 7C3Z-3504-A (Serv) Gas 7C34-3504-CB (Engr) Diesel 7C3Z-3504-B (Serv) Diesel	C	December 19, 2006	December 19, 2006	Y
GEAR ASY - STEERING	July 30, 2007	Added V-flats to mating surface of input shaft to intermediate steering shaft.	To ensure correct installation of new intermediate shaft.	7C34-3504-AB (Engr) Gas 7C3Z-3504-A (Serv) Gas 7C34-3504-CB (Engr) Diesel 7C3Z-3504-B (Serv) Diesel	8C34-3504-AA (Engr) Gas 8C3Z-3504-A (Serv) Gas 8C34-3504-CA (Engr) Diesel 8C3Z-3504-C (Serv) Diesel	S	July 30, 2007	July 30, 2007	N
GEAR ASY - STEERING	July 30, 2007	Double lip input shaft seal	Address Potential Seal Leaks	8C34-3504-AA (Engr) Gas 8C3Z-3504-A (Serv) Gas 8C34-3504-CA (Engr) Diesel 8C3Z-3504-C (Serv) Diesel	8C34-3504-AB (Engr) Gas 8C3Z-3504-A (Serv) Gas 8C34-3504-CB (Engr) Diesel 8C3Z-3504-C (Serv) Diesel	C	July 30, 2007	July 30, 2007	Y
GEAR ASY - STEERING	July 30, 2007	Redundant sector cover seal	Address Potential Seal Leaks	8C34-3504-AB (Engr) 8C3Z-3504-A (Serv) 8C34-3504-CB (Engr) 8C3Z-3504-C (Serv)	8C34-3504-AC (Engr) Gas 8C3Z-3504-A (Serv) Gas 8C34-3504-CC (Engr) Diesel 8C3Z-3504-C (Serv) Diesel	C	July 30, 2007	July 30, 2007	Y

PE13-014

FORD

7/10/2013

Appendix J

Service Part Sales

**2005 through 2009 Ford F250 and F350
Service Part Sales by Year**

Steering Gear Assembly:

Supplier: LTD/BBB Industries
5687 Smithville Highway
Sparta, TN 38583

Contact: Pete Wright
313-529-8471

Engineering Part: 8C34-3504-CA, 8C34-3504-CB, 8C34-3504-CC

Service Part: 8C3Z-3504-CRM

<u>Year</u>	<u>Quantity</u>
2013	2372
2012	4783
2011	7165
2010	4742
2009	1291
2008	0
2007	0
2006	0
2005	0
2004	0

<u>Month</u>	<u>Year</u>	<u>Quantity</u>
6	2013	61
5	2013	393
4	2013	353
3	2013	474
2	2013	423
1	2013	668
12	2012	358
11	2012	442
10	2012	590
9	2012	429
8	2012	441
7	2012	386
6	2012	430
5	2012	318
4	2012	383
3	2012	305
2	2012	259
1	2012	442
12	2011	468
11	2011	511
10	2011	690
9	2011	900
8	2011	619

**2005 through 2009 Ford F250 and F350
Service Part Sales by Year**

7	2011	632
6	2011	862
5	2011	512
4	2011	481
3	2011	659
2	2011	479
1	2011	352
12	2010	407
11	2010	595
10	2010	695
9	2010	597
8	2010	332
7	2010	293

Engineering Part: 8C34-3504-AA, 8C34-3504-AB, 8C34-3504-AC

Service Part: 8C3Z-3504-ARM

<u>Year</u>	<u>Quantity</u>
2013	732
2012	2223
2011	2622
2010	2135
2009	458
2008	0
2007	0
2006	0
2005	0
2004	0

<u>Month</u>	<u>Year</u>	<u>Quantity</u>
6	2013	63
5	2013	113
4	2013	98
3	2013	110
2	2013	133
1	2013	215
12	2012	144
11	2012	143
10	2012	232
9	2012	196
8	2012	201
7	2012	175
6	2012	256
5	2012	119
4	2012	208
3	2012	155
2	2012	167
1	2012	227

**2005 through 2009 Ford F250 and F350
Service Part Sales by Year**

12	2011	171
11	2011	167
10	2011	204
9	2011	445
8	2011	481
7	2011	152
6	2011	219
5	2011	152
4	2011	190
3	2011	165
2	2011	157
1	2011	119
12	2010	170
11	2010	189
10	2010	234
9	2010	224
8	2010	199
7	2010	217

Engineering Part: 7C34-3504-AB
 6C34-3504-AA, 6C34-3504-AB
 5C34-3504-AJ, 5C34-3504-AH
 Service Part: 7C3Z-3504-ARM

<u>Year</u>	<u>Quantity</u>
2013	1036
2012	7184
2011	11368
2010	10451
2009	3859
2008	0
2007	0
2006	0
2005	0
2004	0

<u>Month</u>	<u>Year</u>	<u>Quantity</u>
6	2013	36
5	2013	162
4	2013	170
3	2013	206
2	2013	134
1	2013	328
12	2012	366
11	2012	381
10	2012	583
9	2012	403
8	2012	523

**2005 through 2009 Ford F250 and F350
Service Part Sales by Year**

7	2012	556
6	2012	696
5	2012	629
4	2012	741
3	2012	737
2	2012	679
1	2012	890
12	2011	623
11	2011	618
10	2011	676
9	2011	2480
8	2011	1030
7	2011	598
6	2011	1124
5	2011	835
4	2011	848
3	2011	1156
2	2011	696
1	2011	684
12	2010	732
11	2010	962
10	2010	1135
9	2010	1481
8	2010	569
7	2010	783

Engineering Part: 7C34-3504-CB
 Service Part: 7C3Z-3504-BRM

<u>Year</u>	<u>Quantity</u>
2013	3019
2012	2362
2011	2495
2010	3523
2009	92
2008	0
2007	0
2006	0
2005	0
2004	0

<u>Month</u>	<u>Year</u>	<u>Quantity</u>
6	2013	137
5	2013	567
4	2013	694
3	2013	600
2	2013	534
1	2013	487

**2005 through 2009 Ford F250 and F350
Service Part Sales by Year**

12	2012	182
11	2012	185
10	2012	228
9	2012	165
8	2012	197
7	2012	234
6	2012	198
5	2012	196
4	2012	204
3	2012	207
2	2012	168
1	2012	198
12	2011	209
11	2011	224
10	2011	180
9	2011	185
8	2011	184
7	2011	183
6	2011	237
5	2011	167
4	2011	223
3	2011	327
2	2011	211
1	2011	165
12	2010	258
11	2010	302
10	2010	398
9	2010	443
8	2010	190
7	2010	208

Engineering Part: 8C34-3504-CA, 8C34-3504-CB, 8C34-3504-CC

Service Part: 8C3Z-3504-C

<u>Year</u>	<u>Quantity</u>
2013	0
2012	0
2011	0
2010	0
2009	1472
2008	1046
2007	76
2006	0
2005	0
2004	0

**2005 through 2009 Ford F250 and F350
Service Part Sales by Year**

Engineering Part: 8C34-3504-AA, 8C34-3504-AB, 8C34-3504-AC
Service Part: 8C3Z-3504-A

<u>Year</u>	<u>Quantity</u>
2013	0
2012	0
2011	0
2010	3
2009	707
2008	1663
2007	110
2006	0
2005	0
2004	0

Engineering Part: 7C34-3504-CB
Service Part: 7C3Z-3504-B

<u>Year</u>	<u>Quantity</u>
2013	0
2012	0
2011	0
2010	151
2009	2556
2008	2335
2007	938
2006	1
2005	0
2004	0

Engineering Part: 7C34-3504-AB
Service Part: 7C3Z-3504-A

<u>Year</u>	<u>Quantity</u>
2013	0
2012	0
2011	0
2010	80
2009	5094
2008	8420
2007	9737
2006	706
2005	0
2004	0

**2005 through 2009 Ford F250 and F350
Service Part Sales by Year**

Engineering Part: 6C34-3504-AB
Service Part: 6C3Z-3504-AB

<u>Year</u>	<u>Quantity</u>
2013	0
2012	0
2011	0
2010	0
2009	0
2008	0
2007	0
2006	0
2005	0
2004	0

Engineering Part: 6C34-3504-AA
Service Part: 6C3Z-3504-A

<u>Year</u>	<u>Quantity</u>
2013	0
2012	0
2011	0
2010	0
2009	0
2008	0
2007	23
2006	5634
2005	0
2004	0

Engineering Part: 5C34-3504-AH, 5C34-3504-AJ
Service Part: 5C3Z-3504-AA

<u>Year</u>	<u>Quantity</u>
2013	0
2012	0
2011	0
2010	0
2009	0
2008	0
2007	0
2006	944
2005	3661
2004	545

PE13-014

FORD

7/10/2013

Appendix K

Weight Ratings

2008 F-250/F-350/F-450 Super Duty® Pickups

Weight Ratings

F-250 Styleside Pickup/Pickup Box Delete⁽¹⁾ – GVWR/Payload/ARC/Spring & GAWR (Front Computer-Selected Except with Snowplow)/Base Curb Weight

Cab Style/ Drive/WB (in.)	Engine/ Transmission	Max. GVWR (lbs.)	Max. Payload (lbs.) ⁽²⁾	OPT/ARC Weight (lbs.) ⁽³⁾	Spring/GAWR (lbs.) ⁽⁴⁾		Base Curb Weight (lbs.)			
					Front Range Min.-Max.	Front Snow- plow	Rear	Front	Rear	Total
Regular Cab 4x2 - 137.0	5.4L/Manual	8800	3010	1100	3800 - 4100	—	5892	3216	2509	5725
	6.8L/Manual	9000	3080	1100	3800 - 4250	—	5892	3360	2500	5860
	6.4L/Manual	9400	2700	1145	4550 - 5000	—	6100	4045	2580	6625
Regular Cab 4x4 - 137.0	5.4L/Manual	9000	2770	1164	4400 - 4800	5600	6100	3604	2561	6165
	6.8L/Manual	9200	2830	1164	4400 - 4800	5600	6100	3739	2561	6300
	6.4L/Manual	9600	2440	1209	4800 - 5600	6000	6100	4439	2646	7085
SuperCab 4x2 - 141.8	5.4L/Manual	9000	2990	1125	3800 - 4400	—	5892	3292	2653	5945
	6.8L/Manual	9200	3050	1125	3950 - 4400	—	5892	3431	2649	6080
	6.4L/Manual	9600	2650	1170	4550 - 5250	—	6100	4146	2729	6875
SuperCab 4x2 - 158	5.4L/Manual	9200	3030	1125	4100 - 4550	—	6100	3415	2685	6100
	6.8L/Manual	9400	3100	1125	4250 - 4700	—	6100	3552	2683	6235
	6.4L/Manual	9800	2730	1170	4850 - 5250	—	6100	4242	2758	7000
SuperCab 4x4 - 141.8	5.4L/Manual	9200	2750	1179	4400 - 4800	5600	6100	3699	2686	6385
	6.8L/Manual	9400	2810	1179	4400 - 5200	5600	6100	3836	2684	6520
	6.4L/Manual	9800	2390	1224	5200 - 6000	6000	6100	4540	2795	7335
SuperCab 4x4 - 158	5.4L/Manual	9400	2790	1179	4400 - 5200	5600	6100	3815	2725	6540
	6.8L/Manual	9600	2850	1179	4800 - 5200	6000	6100	3958	2717	6675
	6.4L/Manual	10,000	2460	1224	5200 - 6000	6000	6100	4645	2815	7460
Crew Cab 4x2 - 156.2	5.4L/Manual	9200	2980	1289	3950 - 4550	—	6100	3412	2738	6150
	6.8L/Manual	9400	3050	1289	4100 - 4700	—	6100	3545	2740	6285
	6.4L/Manual	9800	2670	1334	4700 - 5250	—	6100	4253	2797	7050
Crew Cab 4x2 - 172.4	5.4L/Manual	9400	3060	1289	4100 - 4700	—	6100	3521	2754	6275
	6.8L/Manual	9600	3120	1289	4250 - 4850	—	6100	3655	2755	6410
	6.4L/Manual	10,000	2750	1334	5000 - 5250	—	6100	4344	2831	7175
Crew Cab 4x4 - 156.2	5.4L/Manual	9400	2740	1343	4400 - 5200	5600	6100	3808	2782	6590
	6.8L/Manual	9600	2800	1343	4400 - 5200	6000	6100	3941	2784	6725
	6.4L/Manual	10,000	2410	1388	5200 - 6000	6000	6100	4659	2851	7510
Crew Cab 4x4 - 172.4	5.4L/Manual	9600	2810	1353	4800 - 5600	6000	6100	3924	2791	6715
	6.8L/Manual	9800	2880	1353	4800 - 5600	6000	6100	4050	2800	6850
	6.4L/Manual	10,000	2280	1398	5600 - 6000	6000	6100	4756	2879	7635

(1) Pickup box delete available with Regular Cab 137" WB, SuperCab 158" WB and Crew Cab 172.4" WB models with 5.4L or 6.4L engines only. Base Curb Weights shown above are for completed pickup truck models with standard equipment and the engine/transmission combination indicated. To adjust the "Base Curb Weight" to reflect Pickup Box Delete add 54 lbs. to the "Front" weight and subtract 550 lbs. from the "Total" weight (adjust the "Rear" weight by subtracting "Front" from "Total"). This provides the weight effect of deleting the pickup box, rear step bumper and standard spare tire, wheel and carrier. Please also refer to footnote 3.

(2) Load rating represents maximum allowable weight of people, cargo and body equipment and is reduced by optional equipment weight.

(3) OPT/ARC Weight is the maximum allowable weight for regular production options (OPT) and aftermarket equipment (Accessory Reserve Capacity) for completed pickup truck models with standard equipment and the powertrain combination indicated. To adjust the OPT/ARC weights to reflect Pickup Box Delete add 550 lbs. Please also refer to footnote 1.

(4) Gross Axle Weight Rating is determined by the rated capacity of the minimum component of the axle system (axle, computer-selected springs, wheels, tires) of a specific vehicle. Front and rear GAWRs will, in all cases, sum to a number equal to or greater than the GVWR for the particular vehicle. Maximum loaded vehicle (including passengers, equipment and payload) cannot exceed the GVW rating or GAWR (front or rear).

NOTE: Refer to page 67 for Standard Powertrain/Chassis Equipment Specifications. Refer to pages 81–82 for optional equipment weights.

NOTE: The standard front spring/GAWR on Pickup models is computer-selected based on the total front weight of options ordered. Front spring/GAWR upgrades are in increments of 150 lbs. on 4x2 models with spring ratings from 3650 lbs. to 4850 lbs. and in increments of 400 lbs. on 4x4 models with spring ratings from 4000 lbs. to 6000 lbs. Certain option packages include the following front spring/GAWR upgrades: Heavy Service Suspension Package, Heavy Service Package For Pickup Box Delete and Stabilizer Package - Front springs/GAWR will be selected 1 upgrade higher than standard computer selection; Camper Package - Front springs/GAWR will be selected 2 upgrades higher than standard computer selection on 4x2 models and 1 upgrade higher than standard computer selection on 4x4 models; Snowplow Package - Front springs/GAWR is assigned or specifically selected as shown in the chart above. Front spring/GAWR upgrade is not included if the maximum front spring has been computer-selected as a consequence of options ordered.

2008 F-250/F-350/F-450 Super Duty® Pickups

Weight Ratings cont'd

F-250/F-350/F-450 SD PICKUPS

F-350 SRW Styleside Pickup/Pickup Box Delete⁽¹⁾ with 17" Tires/Wheels – GVWR/Payload/ARC/Spring & GAWR (Front Computer-Selected Except with Snowplow)/Base Curb Weight

Cab Style/ Drive/ WB (in.)	Engine/ Transmission	Maximum GVWR (lbs.) Std./Opt.	Maximum Payload (lbs.) ⁽²⁾ Std./Opt.	OPT/ ARC Weight (lbs.) ⁽³⁾	Spring/GAWR (lbs.) ⁽⁴⁾			Base Curb Weight (lbs.)		
					Front Range Min.-Max.	Front Snow- plow	Rear	Front	Rear	Total
Regular Cab 4x2 - 137.0	6.4L/Manual	10,200/10,100	3470/3270	446	4550-5000	—	7000/6262	4045	2613	6658
Regular Cab 4x4 - 137.0	5.4L/Manual	10,100/10,000	3840/3740	465	4400-4800	5600	7000/6262	3604	2594	6198
	6.8L/Manual	10,200/10,000	3800/3600	465	4400-4800	5600	7000/6262	3739	2594	6333
	6.4L/Manual	10,600/10,000	3410/2810	510	5200-5600	6000	7000/6262	4439	2679	7118
SuperCab 4x2 - 141.8	6.4L/Manual	10,400/10,000	3420/3020	471	4550-5250	—	7000/6262	4146	2762	6908
SuperCab 4x2 - 158	5.4L/Manual	10,100/10,000	3900/3800	426	4100-4550	—	7000/6262	3415	2718	6133
	6.8L/Manual	10,200/10,000	3860/3660	426	4250-4700	—	7000/6262	3552	2716	6268
	6.4L/Manual	10,600/10,000	3490/2890	471	4850-5250	—	7000/6262	4242	2791	7033
SuperCab 4x4 - 141.8	5.4L/Manual	10,200/10,000	3710/3510	480	4400-4800	5600	7000/6262	3699	2719	6418
	6.8L/Manual	10,400/10,000	3780/3380	480	4400-4800	5600	7000/6262	3836	2717	6553
	6.4L/Manual	10,800/10,000	3350/2550	525	5200-6000	6000	7000/6262	4540	2828	7368
SuperCab 4x4 - 158	5.4L/Manual	10,400/10,000	3760/3360	480	4400-5200	5600	7000/6262	3815	2758	6573
	6.8L/Manual	10,600/10,000	3820/3220	480	4800-5200	6000	7000/6262	3958	2750	6708
	6.4L/Manual	11,000/10,000	3430/2430	525	5200-6000	6000	7000/6262	4645	2848	7493
Crew Cab 4x2 - 156.2	5.4L/Manual	10,100/10,000	3850/3750	590	3950-4550	—	7000/6262	3412	2771	6183
	6.8L/Manual	10,200/10,000	3810/3610	590	4100-4700	—	7000/6262	3545	2773	6318
	6.4L/Manual	10,600/10,000	3440/2840	635	4700-5250	—	7000/6262	4253	2830	7083
Crew Cab 4x2 - 172.4	5.4L/Manual	10,200/10,000	3820/3620	590	4250-4850	—	7000/6262	3521	2787	6308
	6.8L/Manual	10,400/10,000	3890/3490	590	4250-4850	—	7000/6262	3655	2788	6443
	6.4L/Manual	10,800/10,000	3510/2710	635	5000-5250	—	7000/6262	4344	2864	7208
Crew Cab 4x4 - 156.2	5.4L/Manual	10,400/10,000	3710/3310	644	4400-5200	5600	7000/6262	3808	2815	6623
	6.8L/Manual	10,600/10,000	3770/3170	644	4400-5200	6000	7000/6262	3941	2817	6758
	6.4L/Manual	11,000/10,000	3380/2380	689	5200-6000	6000	7000/6262	4659	2884	7543
Crew Cab 4x4 - 172.4	5.4L/Manual	10,600/10,000	3780/3180	654	4800-5600	6000	7000/6262	3924	2824	6748
	6.8L/Manual	10,800/10,000	3840/3040	654	4800-5600	6000	7000/6262	4050	2833	6883
	6.4L/Manual	11,200/10,000	3450/2250	699	5600-6000	6000	7000/6262	4756	2912	7668

(1) Pickup box delete available with Regular Cab 137" WB, SuperCab 158" WB and Crew Cab 172.4" WB models with 5.4L or 6.4L engines only. Base Curb Weights shown above are for completed pickup truck models with standard equipment and the engine/transmission combination indicated. To adjust the "Base Curb Weight" to reflect Pickup Box Delete add 54 lbs. to the "Front" weight and subtract 550 lbs. from the "Total" weight (adjust the "Rear" weight by subtracting "Front" from "Total"). This provides the weight effect of deleting the pickup box, rear step bumper and standard spare tire, wheel and carrier. Please also refer to footnote 3.

(2) Load rating represents maximum allowable weight of people, cargo and body equipment and is reduced by optional equipment weight.

(3) OPT/ARC Weight is the maximum allowable weight for regular production options (OPT) and aftermarket equipment (Accessory Reserve Capacity) for completed pickup truck models with standard equipment and the powertrain combination indicated. To adjust the OPT/ARC weights to reflect Pickup Box Delete add 550 lbs. Please also refer to footnote 1.

(4) Gross Axle Weight Rating is determined by the rated capacity of the minimum component of the axle system (axle, computer-selected springs, wheels, tires) of a specific vehicle. Front and rear GAWRs will, in all cases, sum to a number equal to or greater than the GVWR for the particular vehicle. Maximum loaded vehicle (including passengers, equipment and payload) cannot exceed the GVW rating or GAWR (front or rear).

NOTE: Refer to page 68 for Standard Powertrain/Chassis Equipment Specifications. Refer to pages 81–82 for optional equipment weights.

NOTE: The standard front spring/GAWR on Pickup models is computer-selected based on the total front weight of options ordered. Front spring/GAWR upgrades are in increments of 150 lbs. on 4x2 models with spring ratings from 3650 lbs. to 4850 lbs. and in increments of 400 lbs. on 4x4 models with spring ratings from 4000 lbs. to 6000 lbs. Certain option packages include the following front spring/GAWR upgrades: Heavy Service Suspension Package, Heavy Service Package For Pickup Box Delete and Stabilizer Package - Front springs/GAWR will be selected 1 upgrade higher than standard computer selection; Camper Package - Front springs/GAWR will be selected 2 upgrades higher than standard computer selection on 4x2 models and 1 upgrade higher than standard computer selection on 4x4 models; Snowplow Package - Front springs/GAWR is assigned or specifically selected as shown in the chart above. Front spring/GAWR upgrade is not included if the maximum front spring has been computer-selected as a consequence of options ordered.

2008 F-250/F-350/F-450 Super Duty® Pickups

Weight Ratings cont'd

F-350 SRW Styleside Pickup/Pickup Box Delete⁽¹⁾ with 18"/20" Tires/Wheels-GVWR/Payload/ARC/Spring & GAWR (Front Computer-Selected Except with Snowplow)/Base Curb Weight

Cab Style/ Drive/ WB (in.)	Engine/ Transmission	Maximum GVWR (lbs.) Std./Opt.	Maximum Payload (lbs.) ⁽²⁾ Std./Opt.	OPT/ ARC Weight (lbs.) ⁽³⁾	Spring/GAWR (lbs.) ⁽⁴⁾			Base Curb Weight (lbs.)		
					Front Range Min.-Max.	Front Snow-plow	Rear ⁽⁵⁾	Front	Rear	Total
Regular Cab 4x2 - 137.0	5.4L/Manual	10,100/10,000	4170/4070	401	3800-4250	5600	7000/6300	3245	2618	5863
	6.8L/Manual	10,100/10,000	4040/3940	401	3950-4400	5600	7000/6300	3401	2597	5998
	6.4L/Manual	10,700/10,100	3860/3160	446	4550-5000	6000	7000/6693	4062	2701	6763
Regular Cab 4x4 - 137.0	5.4L/Manual	10,500/10,000	4130/3630	465	4400-4800	5600	7000	3635	2668	6303
	6.8L/Manual	10,700/10,000	4190/3490	465	4400-4800	5600	7000	3794	2644	6438
	6.4L/Manual	11,100/10,000	3800/2700	510	5200-5600	6000	7000	4459	2764	7223
SuperCab 4x2 - 141.8	5.4L/Manual	10,100/10,000	3950/3850	426	3800-4400	5600	7000/6300	3329	2754	6083
	6.8L/Manual	10,300/10,000	4010/3710	426	3950-4550	5600	7000/6300	3468	2750	6218
	6.4L/Manual	10,800/10,000	3710/2910	471	4550-5250	6000	7000/6693	4160	2853	7013
SuperCab 4x2 - 158	5.4L/Manual	10,400/10,000	4090-3690	426	4400-5200	5600	7000	3440	2798	6238
	6.8L/Manual	10,600/10,000	4160/3560	426	4250-4700	6000	7000	3577	2796	6373
	6.4L/Manual	11,000/10,000	3790/2790	471	5200-6000	6000	7000	4261	2877	7138
SuperCab 4x4 - 141.8	5.4L/Manual	10,600/10,000	4010/3410	480	4100-4550	5600	7000/6693	3731	2792	6523
	6.8L/Manual	10,800/10,000	4070/3270	480	4250-4700	5600	7000/6693	3885	2773	6658
	6.4L/Manual	11,200/10,000	3650/2450	525	4850-5250	6000	7000/6693	4550	2923	7473
SuperCab 4x4 - 158	5.4L/Manual	10,800/10,000	4050/3250	480	4800-5200	5600	7000	3839	2839	6678
	6.8L/Manual	11,000/10,000	4110/3110	480	4800-5600	6000	7000	4000	2813	6813
	6.4L/Manual	11,400/10,000	3720/2320	525	5600-6000	6000	7000	4666	2932	7598
Crew Cab 4x2 - 156.2	5.4L/Manual	10,400/10,000	4040/3640	590	3950-4550	5600	7000/6693	3442	2846	6288
	6.8L/Manual	10,600/10,000	4110/3510	590	4100-4700	6000	7000/6693	3584	2839	6423
	6.4L/Manual	11,000/10,000	3740/2740	635	4700-5250	6000	7000/6693	4260	2928	7188
Crew Cab 4x2 - 172.4	5.4L/Manual	10,600/10,000	4120/3520	590	4400-5200	6000	7000	3549	2864	6413
	6.8L/Manual	10,800/10,000	4180/3380	590	4800-5200	6000	7000	3695	2853	6548
	6.4L/Manual	11,200/10,000	3810/2610	635	5200-6000	6000	7000	4357	2956	7313
Crew Cab 4x4 - 156.2	5.4L/Manual	10,800/10,000	4000/3200	644	4250-4850	5600	7000/6693	3842	2886	6728
	6.8L/Manual	11,000/10,000	4060/3060	644	4400-5000	6000	7000/6693	3994	2869	6863
	6.4L/Manual	11,400/10,000	3670/2270	689	5000-5250	6000	7000/6693	4660	2988	7648
Crew Cab 4x4 - 172.4	5.4L/Manual	11,000/10,000	4070/3070	654	4800-5600	6000	7000	3945	2908	6853
	6.8L/Manual	11,200/10,000	4140/2940	654	4800-5600	6000	7000	4097	2891	6988
	6.4L/Manual	11,500/10,000	3640/2140	699	5600-6000	6000	7000	4765	3008	7773

- (1) Pickup box delete available with Regular Cab 137" WB, SuperCab 158" WB and Crew Cab 172.4" WB models with 5.4L or 6.4L engines only. Base Curb Weights shown above are for completed pickup truck models with standard equipment and the engine/transmission combination indicated. To adjust the "Base Curb Weight" to reflect Pickup Box Delete add 54 lbs. to the "Front" weight and subtract 550 lbs. from the "Total" weight (adjust the "Rear" weight by subtracting "Front" from "Total"). This provides the weight effect of deleting the pickup box, rear step bumper and standard spare tire, wheel and carrier. Please also refer to footnote 3.
- (2) Load rating represents maximum allowable weight of people, cargo and body equipment and is reduced by optional equipment weight.
- (3) OPT/ARC Weight is the maximum allowable weight for regular production options (OPT) and aftermarket equipment (Accessory Reserve Capacity) for completed pickup truck models with standard equipment and the powertrain combination indicated. To adjust the OPT/ARC weights to reflect Pickup Box Delete add 550 lbs. Please also refer to footnote 1.
- (4) Gross Axle Weight Rating is determined by the rated capacity of the minimum component of the axle system (axle, computer-selected springs, wheels, tires) of a specific vehicle. Front and rear GAWRs will, in all cases, sum to a number equal to or greater than the GVWR for the particular vehicle. Maximum loaded vehicle (including passengers, equipment and payload) cannot exceed the GVW rating or GAWR (front or rear).
- (5) 7000/6390 rear spring/GAWR with optional 10,000 lb. GVWR.

NOTE: Refer to page 68 for Standard Powertrain/Chassis Equipment Specifications. Refer to pages 81-82 for optional equipment weights.

NOTE: The standard front spring/GAWR on Pickup models is computer-selected based on the total front weight of options ordered. Front spring/GAWR upgrades are in increments of 150 lbs. on 4x2 models with spring ratings from 3650 lbs. to 4850 lbs. and in increments of 400 lbs. on 4x4 models with spring ratings from 4000 lbs. to 6000 lbs. Certain option packages include the following front spring/GAWR upgrades: Heavy Service Suspension Package, Heavy Service Package For Pickup Box Delete and Stabilizer Package - Front springs/GAWR will be selected 1 upgrade higher than standard computer selection; Camper Package - Front springs/GAWR will be selected 2 upgrades higher than standard computer selection on 4x2 models and 1 upgrade higher than standard computer selection on 4x4 models; Snowplow Package - Front springs/GAWR is assigned or specifically selected as shown in the chart above. Front spring/GAWR upgrade is not included if the maximum front spring has been computer-selected as a consequence of options ordered.

F-250/F-350/F-450 SD Pickups

2008 F-250/F-350/F-450 Super Duty® Pickups

Weight Ratings cont'd

F-250/F-350/F-450 SD PICKUPS

F-350 DRW Styleside Pickup/Pickup Box Delete⁽¹⁾ – GVWR/Payload/ARC/ Spring & GAWR (Front Computer-Selected)/Base Curb Weight

Cab Style/ Drive/ WB (in.)	Engine/ Transmission	Maximum GVWR (lbs.)	Maximum Payload (lbs.) ⁽²⁾	OPT/ ARC Weight (lbs.) ⁽³⁾	Spring/GAWR (lbs.) ⁽⁴⁾			Base Curb Weight (lbs.)		
					Front Range Min.-Max.	Front Snow- plow	Rear	Front	Rear	Total
Regular Cab 4x2 - 137.0	5.4L/Manual	11,800	5560	383	3800-4250		9000	3266	2909	6175
	6.8L/Manual	12,000	5620	383	3950-4400		9000	3410	2900	6310
	6.4L/Manual	12,400	5250	428	4550-5250		9000	4095	2980	7075
Regular Cab 4x4 - 137.0	5.4L/Manual	12,000	5310	419	4400- 4800	5600	9000	3654	2961	6615
	6.8L/Manual	12,200	5380	419	4400- 5200	5600	9000	3789	2961	6750
	6.4L/Manual	12,600	4980	464	5200-5600	6000	9000	4489	3046	7535
SuperCab 4x2 - 158	5.4L/Manual	12,200	5580	408	4100-4700		9000	3465	3085	6550
	6.8L/Manual	12,400	5640	408	4250-4850		9000	3602	3083	6685
	6.4L/Manual	12,800	5270	453	5000-5250		9000	4292	3158	7450
SuperCab 4x4 - 158	5.4L/Manual	12,400	5340	434	4800- 5200	5600	9000	3865	3125	6990
	6.8L/Manual	12,600	5400	434	4800- 5600	6000	9000	4008	3117	7125
	6.4L/Manual	13,000	5010	479	5600-6000	6000	9000	4695	3215	7910
Crew Cab 4x2 - 156.2	5.4L/Manual	12,200	5530	572	3950-4550		9000	3462	3138	6600
	6.8L/Manual	12,400	5590	572	4100-4700		9000	3595	3140	6735
	6.4L/Manual	12,800	5220	617	4700-5250		9000	4303	3197	7500
Crew Cab 4x2 - 172.4	5.4L/Manual	12,400	5600	572	4250-4850		9000	3571	3154	6725
	6.8L/Manual	12,600	5670	572	4400-5000		9000	3705	3155	6860
	6.4L/Manual	13,000	5290	617	5000-5250		9000	4394	3231	7625
Crew Cab 4x4 - 156.2	5.4L/Manual	12,400	5280	598	4400-5200	5600	9000	3858	3182	7040
	6.8L/Manual	12,600	5350	598	4400- 5200	6000	9000	3991	3184	7175
	6.4L/Manual	13,000	4960	643	5200-6000	6000	9000	4709	3251	7960
Crew Cab 4x4 - 172.4	5.4L/Manual	12,400	5160	608	4800-5600	6000	9000	3975	3191	7165
	6.8L/Manual	12,600	5220	608	4800-5600	6000	9000	4100	3200	7300
	6.4L/Manual	13,000	4830	653	5600-6000	6000	9000	4806	3279	8085

(1) Pickup box delete available with Regular Cab 137" WB, SuperCab 158" WB and Crew Cab 172.4" WB models with 5.4L or 6.4L engines only. Base Curb Weights shown above are for completed pickup truck models with standard equipment and the engine/transmission combination indicated. To adjust the "Base Curb Weight" to reflect Pickup Box Delete add 55 lbs. to the "Front" weight and subtract 591 lbs. from the "Total" weight (adjust the "Rear" weight by subtracting "Front" from "Total"). This provides the weight effect of deleting the pickup box, rear step bumper and standard spare tire, wheel and carrier. Please also refer to footnote 3.

(2) Load rating represents maximum allowable weight of people, cargo and body equipment and is reduced by optional equipment weight.

(3) OPT/ARC Weight is the maximum allowable weight for regular production options (OPT) and aftermarket equipment (Accessory Reserve Capacity) for completed pickup truck models with standard equipment and the engine/transmission combination indicated. To adjust the OPT/ARC weights to reflect Pickup Box Delete add 591 lbs. Please also refer to footnote 1.

(4) Gross Axle Weight Rating is determined by the rated capacity of the minimum component of the axle system (axle, computer-selected springs, wheels, tires) of a specific vehicle. Front and rear GAWRs will, in all cases, sum to a number equal to or greater than the GVWR for the particular vehicle. Maximum loaded vehicle (including passengers, equipment and payload) cannot exceed the GVW rating or GAWR (front or rear).

NOTE: Refer to page 69 for Standard Powertrain/Chassis Equipment Specifications. Refer to pages 81-82 for optional equipment weights.

NOTE: The standard front spring/GAWR on Pickup models is computer-selected based on the total front weight of options ordered. Front spring/GAWR upgrades are in increments of 150 lbs. on 4x2 models with spring ratings from 3800 lbs. to 4850 lbs. and in increments of 400 lbs. on 4x4 models with spring ratings from 4400 lbs. to 6000 lbs. Certain option packages include the following front spring/GAWR upgrades: Heavy Service Suspension Package - Front springs/GAWR will be selected 1 upgrade higher than standard computer selection; Camper Package - Front springs/GAWR will be selected 2 upgrades higher than standard computer selection on 4x2 models and 1 upgrade higher than standard computer selection on 4x4 models; Snowplow Package - Front springs/GAWR is assigned or specifically selected as shown in the chart above. Front spring/GAWR upgrade is not included if the maximum front spring has been computer-selected as a consequence of options ordered.



If your vehicle will be registered in California, Maine, Massachusetts, New York or Vermont, check with your Ford Dealer to be sure the desired powertrain/axle ratio is available in your area.

F-250/F-350/F-450 SUPER DUTY® PICKUP CONVENTIONAL TOWING

Maximum Loaded Trailer Weight (Lbs.) – Automatic Transmission

Engine	Axle Ratio	GCWR (Lbs.)	REGULAR CAB				SUPERCAB				CREW CAB					
			F-250/F-350 SRW 4x2	F-250/F-350 SRW 4x4	F-350 DRW 4x2	F-350 DRW 4x4	F-250/F-350 SRW 4x2	F-250/F-350 SRW 4x4	F-350 DRW 4x2	F-350 DRW 4x4	F-250/F-350 SRW 4x2	F-250/F-350 SRW 4x4	F-350 DRW 4x2	F-350 DRW 4x4	F-450 DRW 4x2	F-450 DRW 4x4
			6.4L SEFI V8	3.73	16,000	10,100	9,600	-	-	9,900	9,400	-	-	9,700	9,200	-
	4.10	18,000	12,100	11,600	-	-	11,900	11,400	-	-	11,700	11,200	-	-	-	-
		18,500	-	-	12,100	11,700	-	-	11,800	11,300	-	-	11,700	11,200	-	-
6.8L SEFI V10	4.10	21,000	12,500	12,500	-	-	12,500	12,500	-	-	12,500	12,500	-	-	-	-
		21,500	-	-	15,000	14,600	-	-	14,600	14,200	-	-	14,600	14,100	-	-
	4.30	22,500/23,000(1)	12,500	12,500	-	-	12,500	12,500	-	-	12,500	12,500	-	-	-	-
		23,000	-	-	15,000	15,000	-	-	15,000	15,000	-	-	15,000	15,000	-	-
6.4L V8	3.73	23,000	12,500	12,500	-	-	12,500	12,500	-	-	12,500	12,500	-	-	-	-
Turbo Diesel		23,500	-	-	15,000	15,000	-	-	15,000	15,000	-	-	15,000	15,000	-	-
	4.10	23,500	-	-	15,000	15,000	-	-	15,000	15,000	-	-	15,000	15,000	-	-
	4.30LS	26,000(2)	-	-	15,000	15,000	-	-	15,000	15,000	-	-	15,000	15,000	-	-
		29,000	-	-	-	-	-	-	-	-	-	-	-	-	16,000	16,000
	4.88LS	33,000(3)	-	-	-	-	-	-	-	-	-	-	-	-	16,000	16,000

Maximum Loaded Trailer Weight (Lbs.) – Manual Transmission

6.4L SEFI V8	3.73	15,000	9,100	8,600	-	-	8,900	8,400	-	-	8,700	8,200	-	-	-	-
	4.10	17,000	11,100	10,600	-	-	10,900	10,400	-	-	10,700	10,200	-	-	-	-
		17,500	-	-	11,100	10,700	-	-	10,800	10,300	-	-	10,700	10,200	-	-
6.8L SEFI V10	4.10	20,000	12,500	12,500	-	-	12,500	12,500	-	-	12,500	12,500	-	-	-	-
		20,500	-	-	14,000	13,600	-	-	13,600	13,200	-	-	13,600	13,100	-	-
	4.30	22,000	12,500	12,500	-	-	12,500	12,500	-	-	12,500	12,500	-	-	-	-
		22,500	-	-	15,000	15,000	-	-	15,000	15,000	-	-	15,000	15,000	-	-
6.4L V8	3.73	23,000	12,500	12,500	-	-	12,500	12,500	-	-	12,500	12,500	-	-	-	-
Turbo Diesel		23,500	-	-	15,000	15,000	-	-	15,000	15,000	-	-	15,000	15,000	-	-
	4.10	23,500	-	-	15,000	15,000	-	-	15,000	15,000	-	-	15,000	15,000	-	-
	4.30LS	27,000	-	-	-	-	-	-	-	-	-	-	-	-	16,000	16,000
	4.88LS	28,000	-	-	-	-	-	-	-	-	-	-	-	-	16,000	16,000

(1) Available with F-350 SRW model only. (2) Available with TowBoss Package only. (3) Available with High-Capacity Trailer Towing Package only.

Notes: • This information also applies to models with Pickup Box Delete option (66D).

• For F-250/F-350 SRW models, F-250 trailer weights are shown. F-350 trailer weights are within 200 pounds. Check with your sales consultant.

• Trailer tongue load weight should be 10-15% of total loaded trailer weight. Make sure vehicle payload (reduced by option weight) will accommodate trailer tongue load weight and weight of passengers and cargo added to towing vehicle. Addition of trailer tongue load weight and weight of passengers and cargo cannot cause vehicle weights to exceed rear GAWR or GVWR. These ratings can be found on the vehicle Safety Compliance Certification Label.

If your vehicle will be registered in California, Maine, Massachusetts, New York or Vermont, check with your Ford Dealer to be sure the desired powertrain/axle ratio is available in your area.

F-250/F-350/F-450 SUPER DUTY® PICKUP FIFTH-WHEEL TOWING (1)

Maximum Loaded Trailer Weight (Lbs.) – Automatic Transmission

Engine	Axle Ratio	GCWR (Lbs.)	REGULAR CAB		SUPERCAB				CREW CAB							
			F-250/F-350 SRW 4x2	F-250/F-350 SRW 4x4	F-350 DRW 4x2	F-350 DRW 4x4	F-250/F-350 SRW 4x2	F-250/F-350 SRW 4x4	F-350 DRW 4x2	F-350 DRW 4x4	F-250/F-350 SRW 4x2	F-250/F-350 SRW 4x4	F-350 DRW 4x2	F-350 DRW 4x4	F-450 DRW 4x2	F-450 DRW 4x4
			5.4L SEFI V8	3.73	16,000	10,100	9,600	-	-	9,900	9,400	-	-	9,700	9,200	-
	4.10	18,000	12,100	11,600	-	-	11,900	11,400	-	-	11,700	11,200	-	-	-	-
		18,500	-	-	12,100	11,700	-	-	11,800	11,300	-	-	11,700	11,200	-	-
6.8L SEFI V10	4.10	21,000	14,900	14,500	-	-	14,700	14,300	-	-	14,500	14,000	-	-	-	-
		21,500	-	-	15,000	14,600	-	-	14,600	14,200	-	-	14,600	14,100	-	-
	4.30	22,500/23,000(2)	16,400/16,800(2)	16,000/16,300(2)	-	-	16,200/16,600(2)	15,800/16,100(2)	-	-	16,000/16,400(2)	15,500/15,900(2)	-	-	-	-
		23,000	-	-	16,500	16,100	-	-	16,100	15,700	-	-	16,100	15,600	-	-
6.4L V8	3.73	23,000	16,200	15,700	-	-	15,900	15,400	-	-	15,800	15,200	-	-	-	-
Turbo Diesel		23,500	-	-	16,200	15,800	-	-	15,900	15,400	-	-	15,800	15,300	-	-
	4.10	23,500	-	-	16,200	15,800	-	-	15,900	15,400	-	-	15,800	15,300	-	-
	4.30LS	26,000(3)	-	-	18,700	18,300	-	-	18,400	17,900	-	-	18,300	17,800	-	-
		29,000	-	-	-	-	-	-	-	-	-	-	-	-	20,500	20,100
	4.88LS	33,000(4)	-	-	-	-	-	-	-	-	-	-	-	-	24,500	24,100

Maximum Loaded Trailer Weight (Lbs.) – Manual Transmission

5.4L SEFI V8	3.73	15,000	9,100	8,600	-	-	8,900	8,400	-	-	8,700	8,200	-	-	-	-
	4.10	17,000	11,100	10,600	-	-	10,900	10,400	-	-	10,700	10,200	-	-	-	-
		17,500	-	-	11,100	10,700	-	-	10,800	10,300	-	-	10,700	10,200	-	-
6.8L SEFI V10	4.10	20,000	13,900	13,500	-	-	13,700	13,200	-	-	13,500	13,000	-	-	-	-
		20,500	-	-	14,000	13,600	-	-	13,600	13,200	-	-	13,600	13,100	-	-
	4.30	22,000	15,900	15,500	-	-	15,700	15,200	-	-	15,500	15,000	-	-	-	-
		22,500	-	-	16,000	15,600	-	-	15,600	15,200	-	-	15,600	15,100	-	-
6.4L V8	3.73	23,000	16,200	15,700	-	-	15,900	15,400	-	-	15,800	15,200	-	-	-	-
Turbo Diesel		23,500	-	-	16,200	15,800	-	-	15,800	15,400	-	-	15,800	15,300	-	-
	4.10	23,500	-	-	16,200	15,800	-	-	15,800	15,400	-	-	15,800	15,300	-	-
	4.30LS	27,000	-	-	-	-	-	-	-	-	-	-	-	-	18,500	18,100
	4.88LS	28,000	-	-	-	-	-	-	-	-	-	-	-	-	19,500	19,100

(1) Super Duty does not offer a fifth-wheel hitch as a factory-installed option. (2) Available with F-350 SRW model only. (3) Available with TowBoss Package only.

(4) Available with High-Capacity Trailer Towing Package only.

Notes: • This information also applies to models with Pickup Box Delete option (66D).

• For F-250/F-350 SRW models, F-250 trailer weights are shown. F-350 trailer weights are within 200 pounds. Check with your sales consultant.

• Trailer king pin weight should be 15-25% of total loaded trailer weight. Make sure vehicle payload (reduced by option weight) will accommodate trailer king pin weight and weight of passengers and cargo added to the towing vehicle. Addition of trailer king pin weight, and weight of passengers and cargo cannot cause vehicle weights to exceed rear GAWR or GVWR. These ratings can be found on the vehicle Safety Compliance Certification Label.



PE13-014

FORD

7/10/2013

Appendix L

Steering System Diagrams

Steering Column

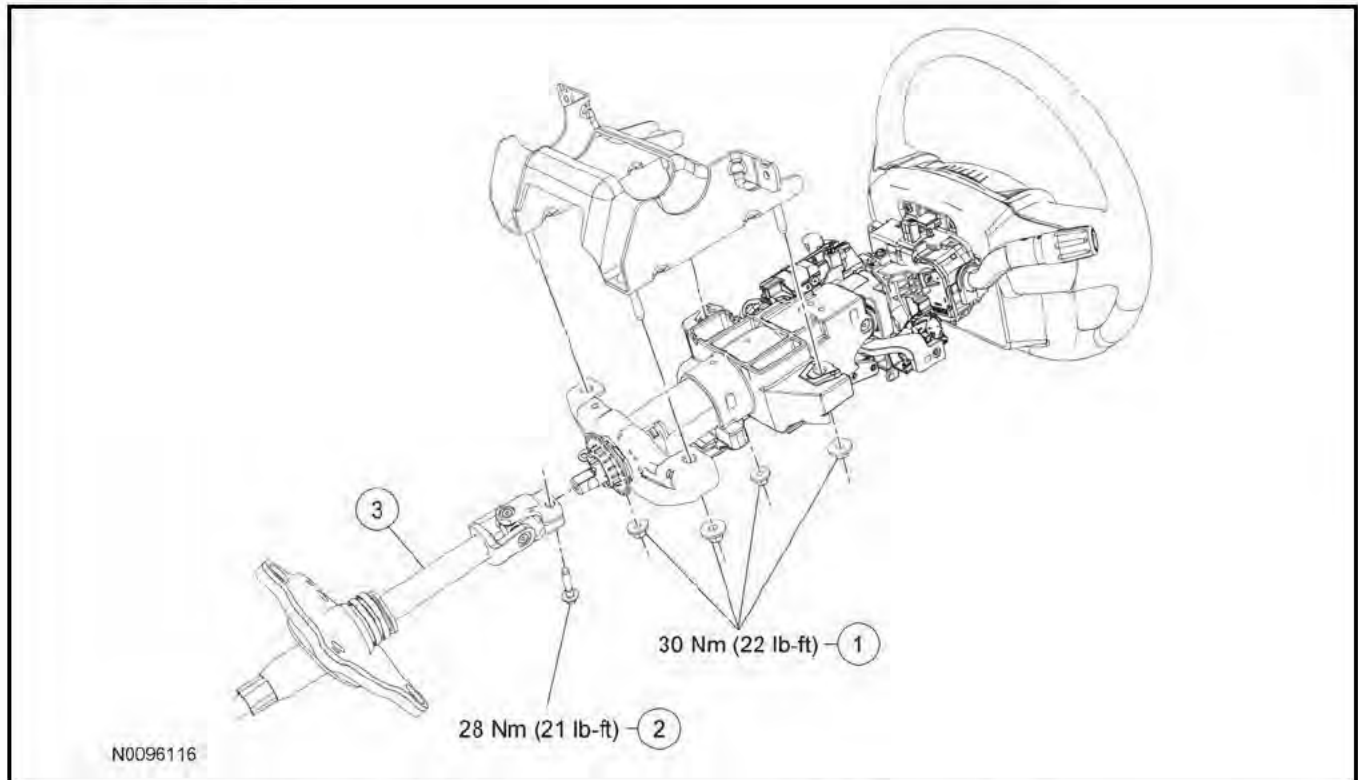

Item	Part Number	Description
1	N806423	Steering column to instrument panel nuts (4 required)
2	N808684	Steering column shaft to steering column bolt
3	3E751	Upper steering column shaft

Steering Column Shaft

NOTE:

F 350/450 shown, F 450/550 similar.

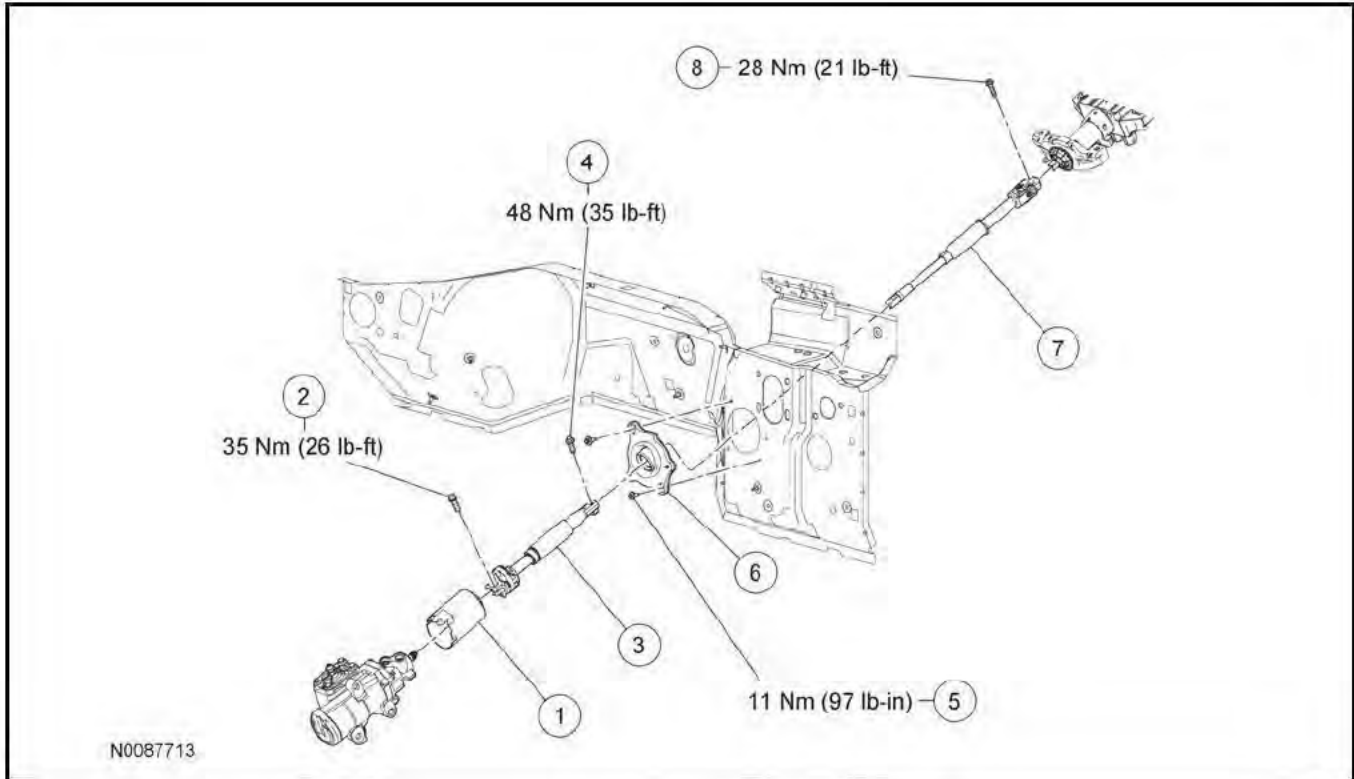

Item	Part Number	Description
1	3F450	Steering gear shield
2	N803942	Lower steering column shaft to steering gear bolt
3	3C662	Lower steering column shaft
4	W710570	Upper steering column shaft to lower steering column shaft bolt
5	W705132	Steering column shaft dash seal bolt (2 required)
6	3D677	Upper steering column shaft dash seal
7	3E157	Upper steering column shaft
8	N808684	Upper steering column shaft to steering column bolt

Removal and Installation

1. With the vehicle in NEUTRAL, position the vehicle on a hoist. For additional information, refer to Section 100 02.

2. **NOTE:**

Use a steering wheel holding device (such as Hunter® 28 75 1 or equivalent).

Using a suitable holding device, hold the steering wheel in the straight ahead position.

(Continued)

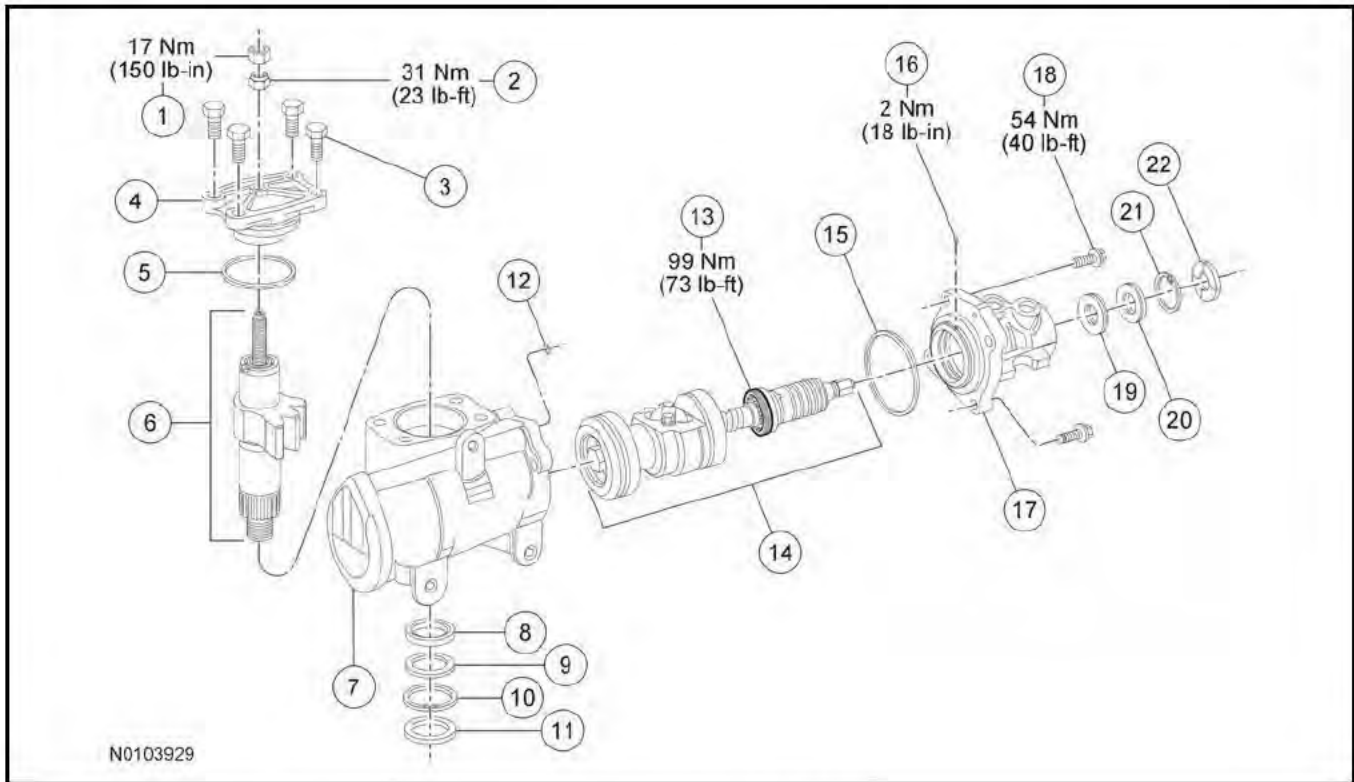

Item	Part Number	Description
1	19G405	Meshload adjusting screw jam nut
2		Meshload adjusting screw locknut (part of 3L548 seal kit)
3	N808939	Sector shaft housing cover bolt (4 required)
4		Sector shaft housing cover
5		Sector shaft housing cover seal (part of 3L548 seal kit)
6		Sector shaft and meshload adjusting screw assembly (part of 3504)
7		Steering gear housing (part of 3504)
8		Sector shaft seal (part of 3L548 seal kit)
9		Spacer (part of 3L548 seal kit)
10		Snap ring (part of 3L548 seal kit)
11		Sector shaft dust seal (part of 3L548 seal kit)
12		Valve housing to gear housing O ring seal (part of 3L548 seal kit)
13		Worm thrust bearing retainer ring (part of 3504)
14		Piston assembly (part of 3504)
15		Valve housing seal (part of 3L548 seal kit)
16		Worm thrust bearing retainer ring setscrew (part of 3L548 seal kit)
17		Valve housing (part of 3504)
18	3885578	Valve housing bolt (4 required)
19		Input shaft bearing (part of 3504)
20		Input shaft seal (part of 3L548 seal kit)
21		Snap ring (part of 3L548 seal kit)
22		Input shaft dust seal (part of 3L548 seal kit)

NOTICE:

While repairing the power steering system, care should be taken to prevent the entry of contaminants, or premature failure of the power steering components may result.

REMOVAL AND INSTALLATION

Steering Linkage — Exploded View

F-250/350 Rear Wheel Drive (RWD)

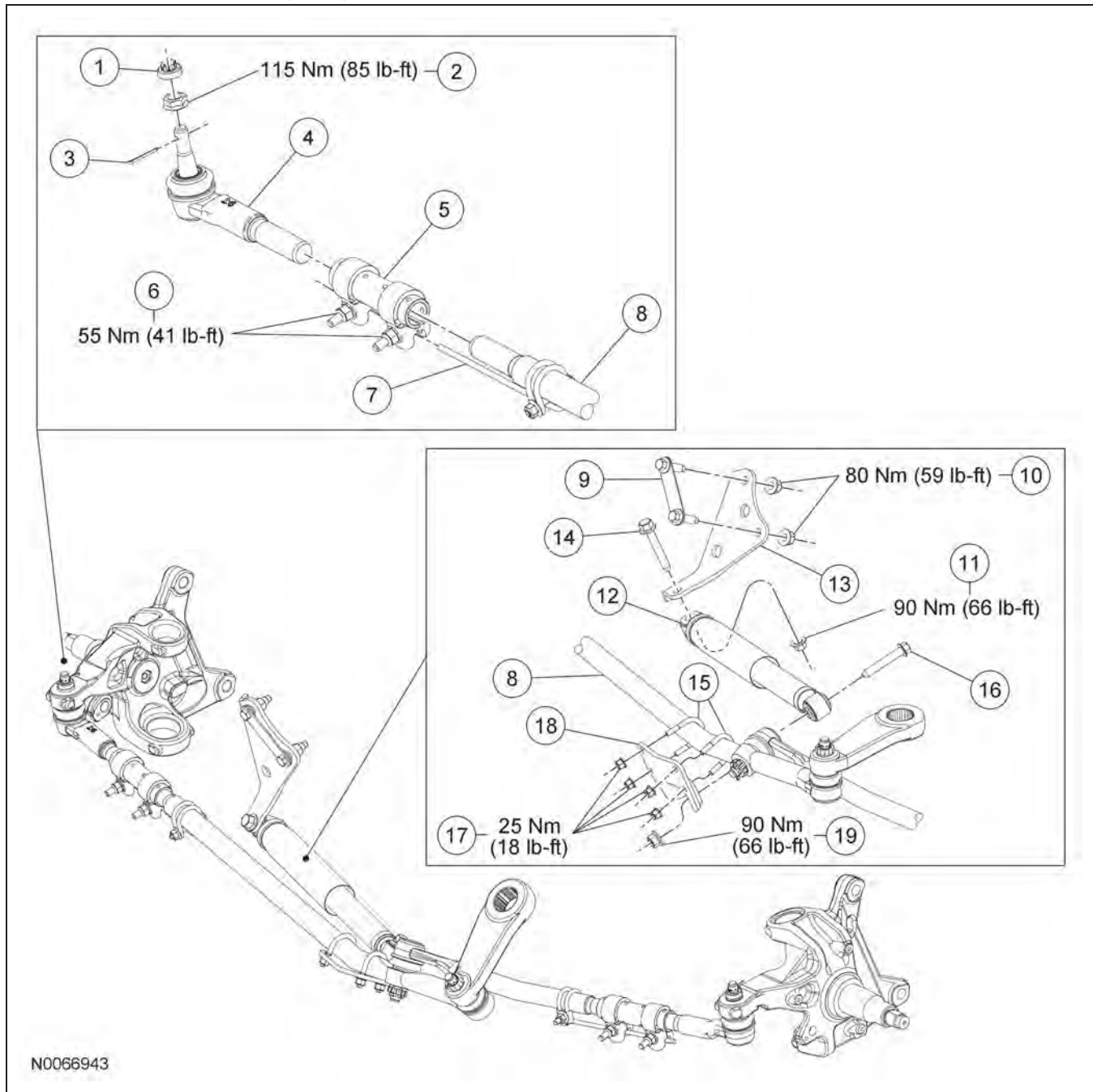

Item	Part Number	Description
1	W711374	Outer drag link nut retainer
2	W711373	Outer drag link nut
3	N642569	Cotter pin (4 required)
4	3A131A	Outer tie-rod end
5	3280	Adjusting sleeve

(Continued)

Item	Part Number	Description
6	W520213	Adjusting sleeve clamp nuts (2 required) (part of 3280)
7	—	Drag link adjusting sleeve aligner bracket (part of 3304)
8	3304	Inner drag link

(Continued)

REMOVAL AND INSTALLATION (Continued)

Item	Part Number	Description
9	W712055	Steering linkage damper frame bracket bolt plate and bolts
10	W520114	Steering linkage damper frame bracket nuts (2 required)
11	W520114	Steering linkage damper-to-frame bracket nut
12	3E651	Steering linkage damper
13	3E652	Steering linkage damper frame bracket
14	W706196	Steering linkage damper-to-frame bracket bolt
15	—	Steering linkage damper-to-drag link bracket U-bolts (2 required) (part of 3304)

(Continued)

Item	Part Number	Description
16	W706196	Steering linkage damper-to-drag link bracket bolt
17	N620481	Steering linkage damper-to-drag link bracket U-bolt nuts (4 required) (part of 3304)
18	—	Steering linkage damper-to-drag link bracket (part of 3304)
19	W520114	Steering linkage damper-to-drag link bracket nut

REMOVAL AND INSTALLATION (Continued)

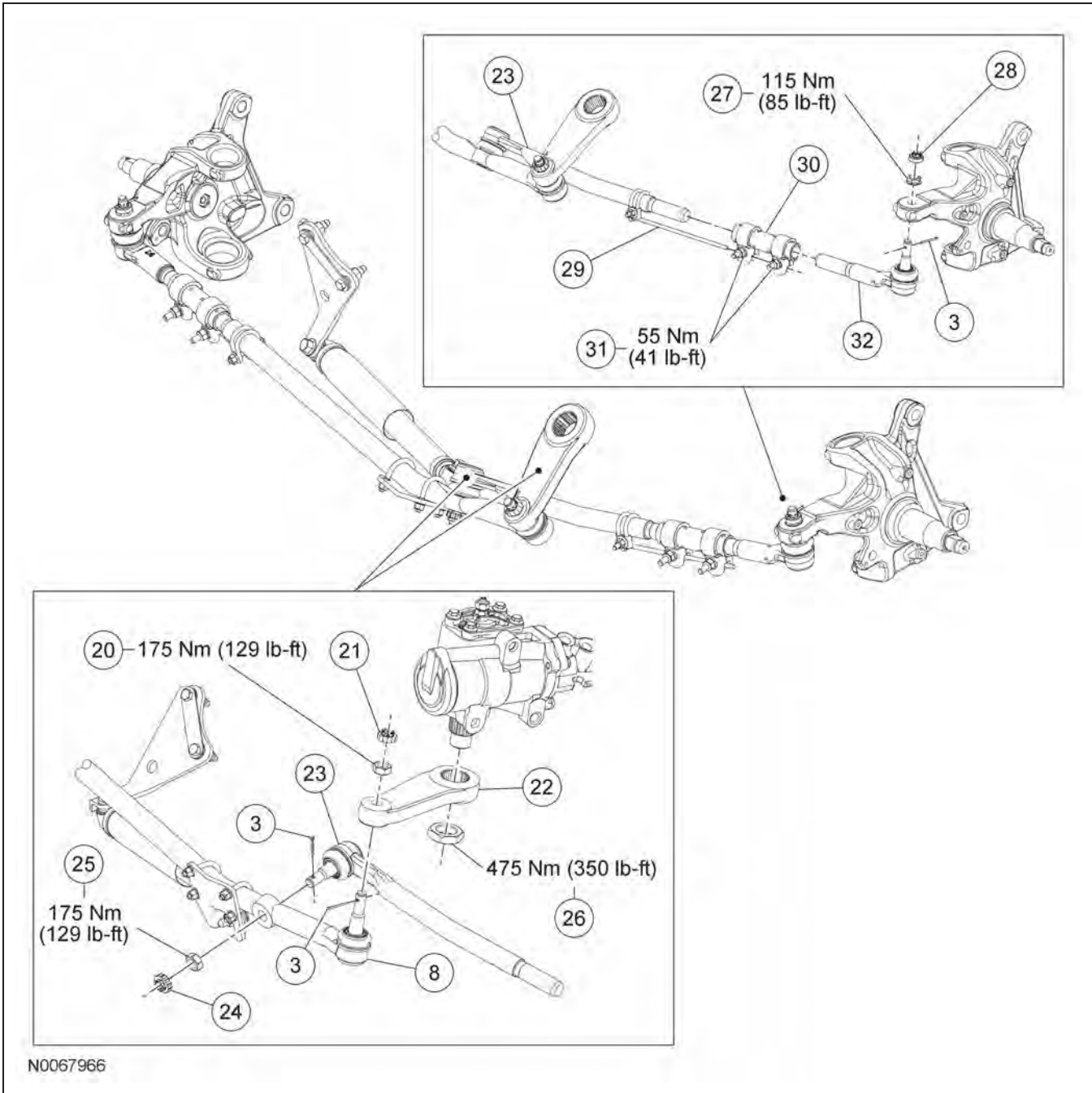

N0067966

Item	Part Number	Description
20	W712367	Inner drag link nut
21	W710907	Inner drag link nut retainer
22	3590	Sector shaft arm
23	3A131B	Inner tie-rod end
24	W710907	Inner tie-rod end nut retainer
25	W712367	Inner tie-rod end nut
26	W709296	Sector shaft arm nut
27	W711373	Outer tie-rod end nut

Item	Part Number	Description
28	W711374	Outer tie-rod end nut retainer
29	—	Adjusting sleeve aligner bracket (part of 3A131B)
30	3281	Adjusting sleeve
31	W520213	Adjusting sleeve clamp nuts (2 required) (part of 3281)
32	3A131C	Outer tie-rod end

(Continued)

REMOVAL AND INSTALLATION (Continued)

NOTE: F-450/550 shown, F-250/350 four wheel drive (4WD) similar.

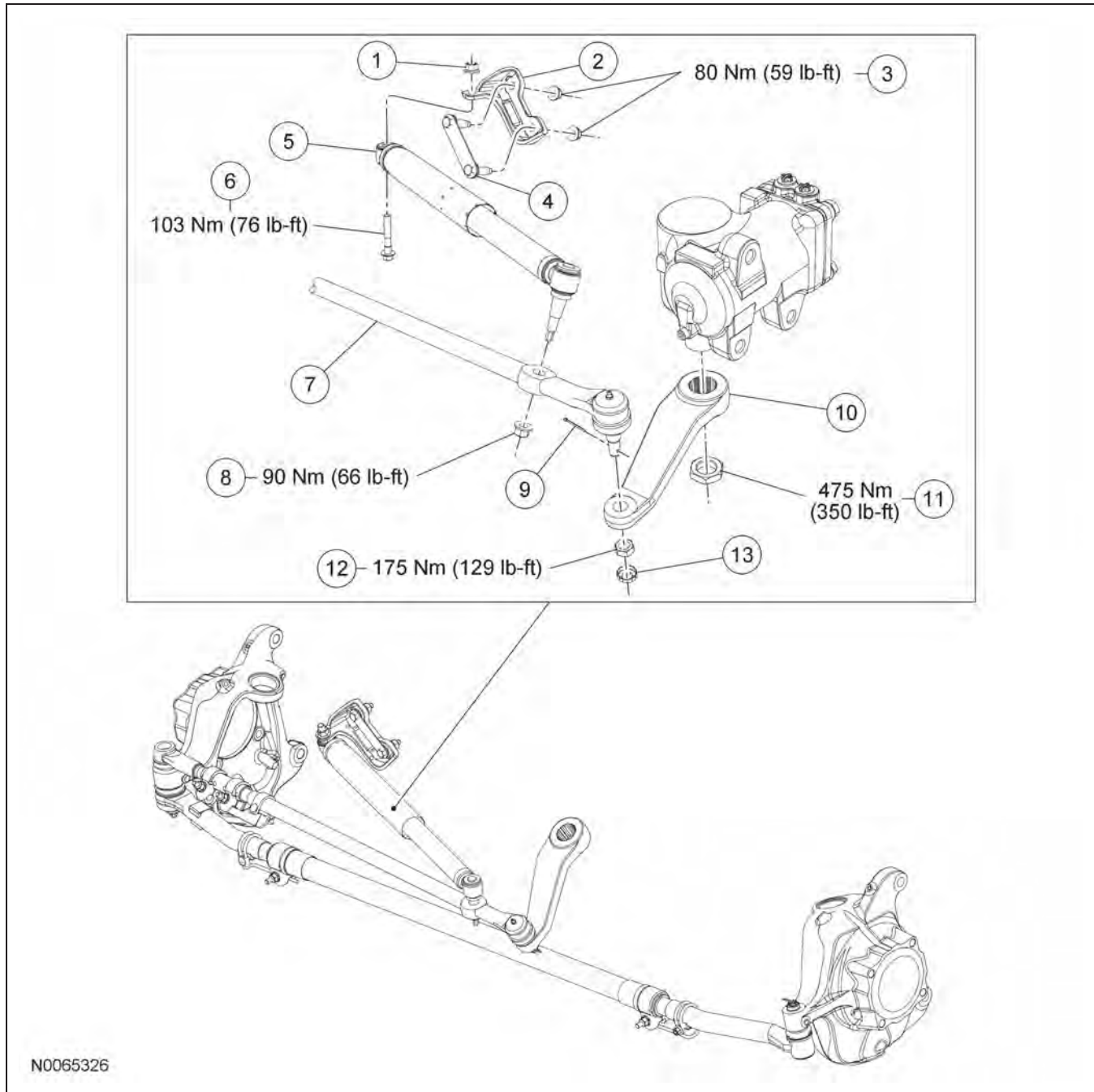

N0065326

Item	Part Number	Description
1	W520114	Steering linkage damper-to-frame bracket nut
2	3E652	Steering linkage damper frame bracket
3	W520114	Steering linkage damper frame bracket nuts
4	W712055	Steering linkage damper frame bracket bolt plate and bolts

(Continued)

Item	Part Number	Description
5	3E651	Steering linkage damper
6	706196	Steering linkage damper-to-frame bracket bolt
7	3304B	Inner drag link
8	W520114	Steering linkage damper-to-drag link nut
9	N642569	Cotter pin (3 required)
10	3590	Sector shaft arm
11	W709296	Sector shaft arm nut

(Continued)

REMOVAL AND INSTALLATION (Continued)

Item	Part Number	Description
12	W712367	Inner drag link nut

Item	Part Number	Description
13	W710907	Inner drag link nut retainer

(Continued)

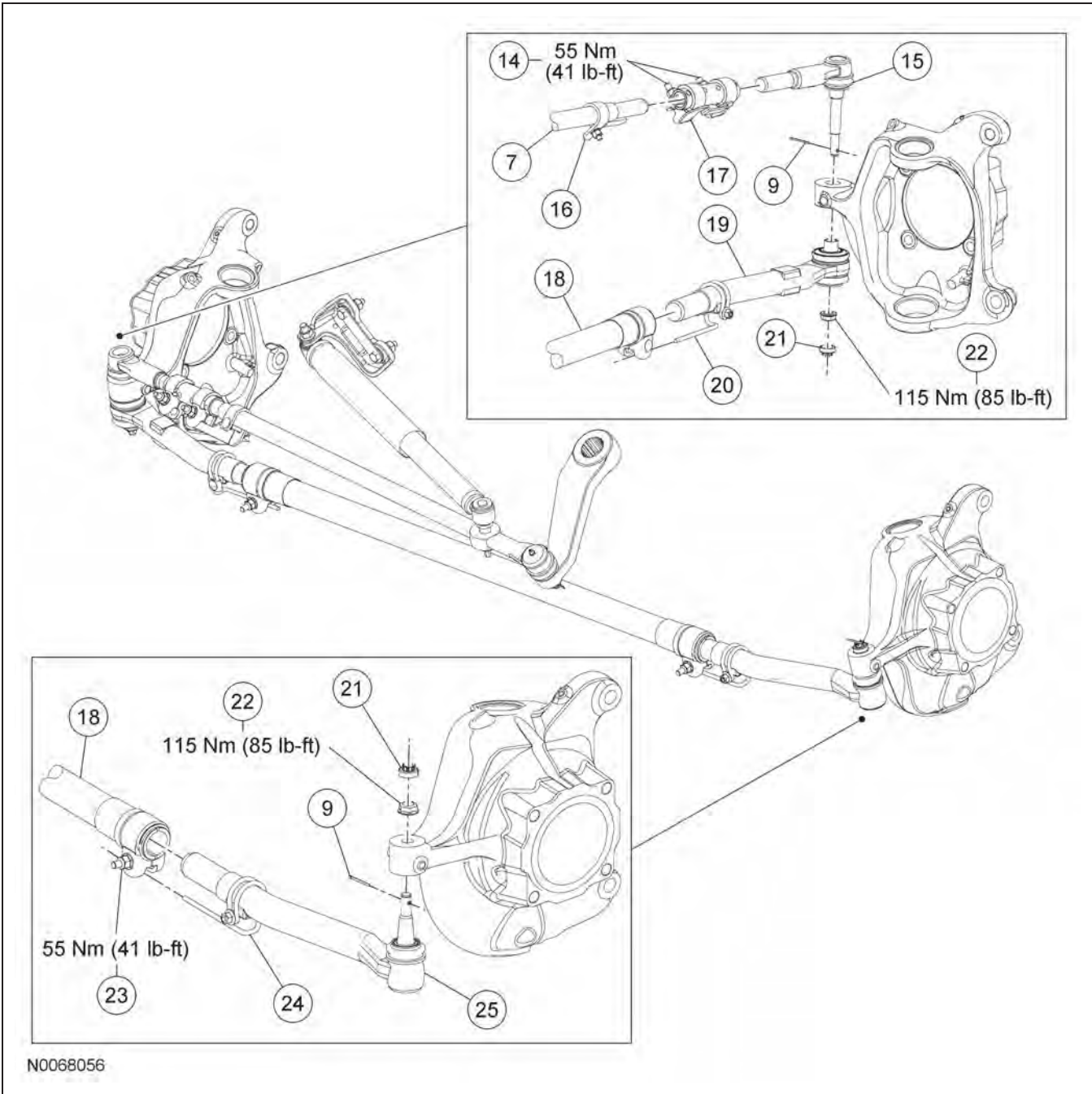

N0068056

Item	Part Number	Description
14	W520213	Adjusting sleeve clamp nuts (part of 3280)
15	3304A	Outer drag link
16	—	Adjusting sleeve aligner bracket (part of 3304B)
17	3280	Adjusting sleeve

(Continued)

Item	Part Number	Description
18	3281	Adjusting sleeve
19	3A130A	RH outer tie-rod end
20	—	Adjusting sleeve aligner bracket (part of 3A130A)
21	W711374	Outer tie-rod end nut retainer (2 required)

(Continued)

REMOVAL AND INSTALLATION (Continued)

Item	Part Number	Description
22	W711373	Outer tie-rod end nut (2 required)
23	W520213	Adjusting sleeve clamp nut (2 required) (part of 3281)
24	—	Adjusting sleeve aligner bracket (part of 3A130B)

(Continued)

Item	Part Number	Description
25	3A130B	LH outer tie-rod end

1. For additional information, refer to the procedures in this section.

Steering Gear to Fluid Cooler Return Hose

Material

Item	Specification
MERCON® V Automatic Transmission Fluid XT 5 QM (or XT 5 QMC) (US); CXT 5 LM12 (Canada)	MERCON® V

NOTE:

Vehicles with 6.4L engine shown, 5.4L and 6.8L engine similar.

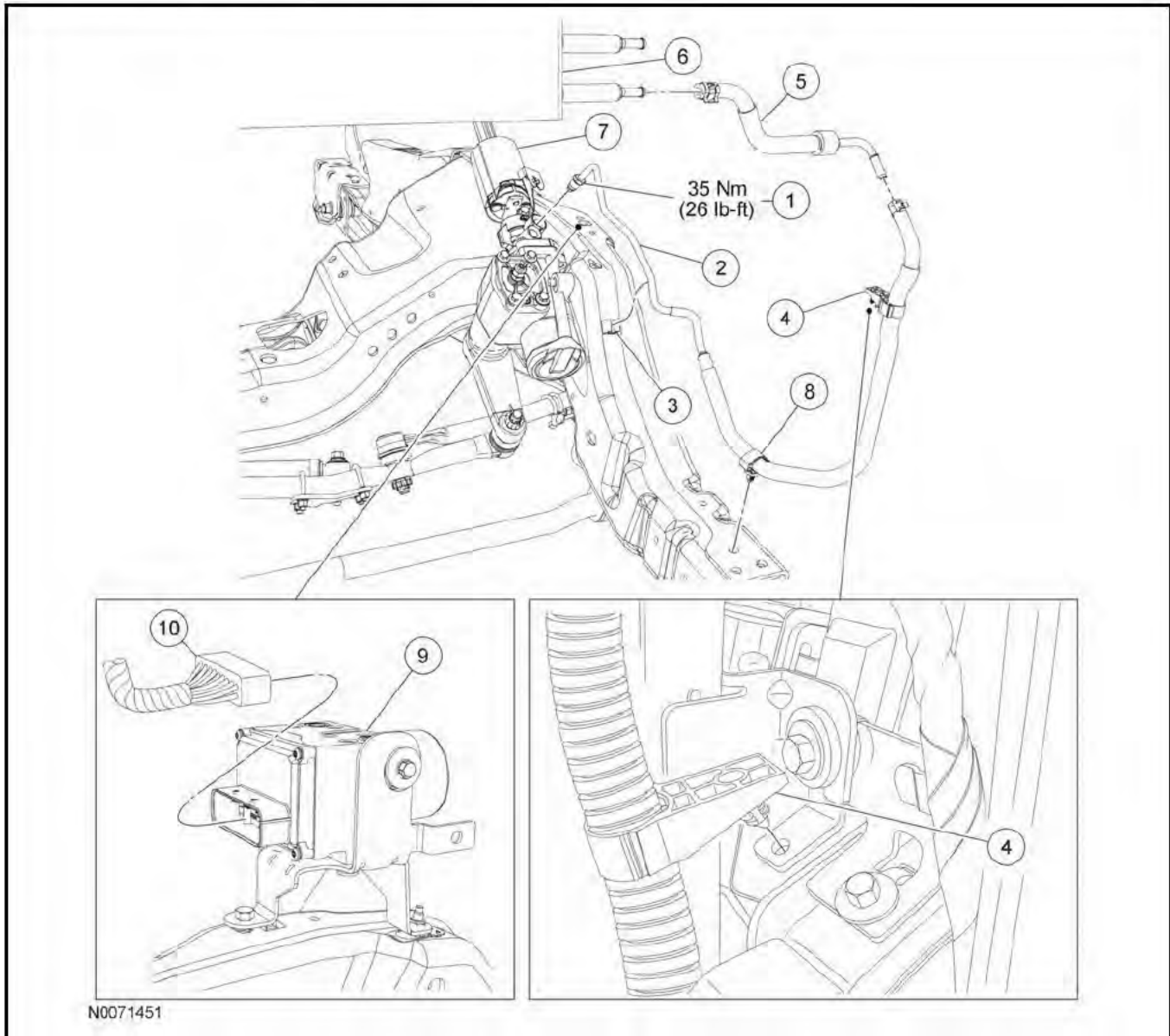

N0071451

Item	Part Number	Description
1		Return hose to steering gear fitting (part of 3A713)
2	3A713	Power steering gear to fluid cooler return hose
3		Steering gear to fluid cooler return hose retainer (part of 3A713)
4		Steering gear to fluid cooler return hose retainer (part of 3A713) (6.4L engine only)
5	3A713	Power steering fluid cooler jumper line (6.4L engine only)

(Continued)

Item	Part Number	Description
6	3D746	Power steering fluid cooler
7	3F540	Steering gear shield
8		Steering gear to fluid cooler return hose retainer (part of 3A713)
9	2C286	Hydraulic Control Unit (HCU)
10		ABS module electrical connector (part of 14405)

Removal and Installation

NOTICE:

While repairing the power steering system, care should be taken to prevent the entry of foreign material or failure of the power steering components may result.

Vehicles with 5.4L and 6.8L engine

1. Remove the air cleaner intake pipe. For additional information, refer to Section 303 12.

All vehicles

2. Using a suitable suction device, drain the power steering fluid reservoir.

Vehicles with 6.4L engine

3. Remove the fender splash shield. For additional information, refer to Section 501 02.
4. Disconnect and position aside the ABS module electrical connector.

All vehicles

5. Disconnect the steering gear shield from the line fitting and position the shield up on the lower steering column shaft.
6. Disconnect the return hose to steering gear fitting.
 - To install, tighten to 35 Nm (26 lb ft).
7. Unclip the steering gear to fluid cooler return hose from the 2 steering gear to fluid cooler return hose retainers.

Vehicles with 6.4L engine

8. Unclip the steering gear to fluid cooler return hose retainer from the fuel air charge cooler bracket.
9. Remove the left side fog lamp and bracket assembly. For additional information, refer to Section 417 01.

All vehicles

10. Release the steering gear to fluid cooler return hose clamp and remove the steering gear to fluid cooler return hose.
11. To install, reverse the removal procedure.
12. Fill the power steering system. For additional information, refer to Section 211 00.

Power Steering Pump to Steering Gear Pressure Line

Material

Item	Specification
MERCON® V Automatic Transmission Fluid XT 5 QM (or XT 5 QMC) (US); CXT 5 LM12 (Canada)	MERCON® V

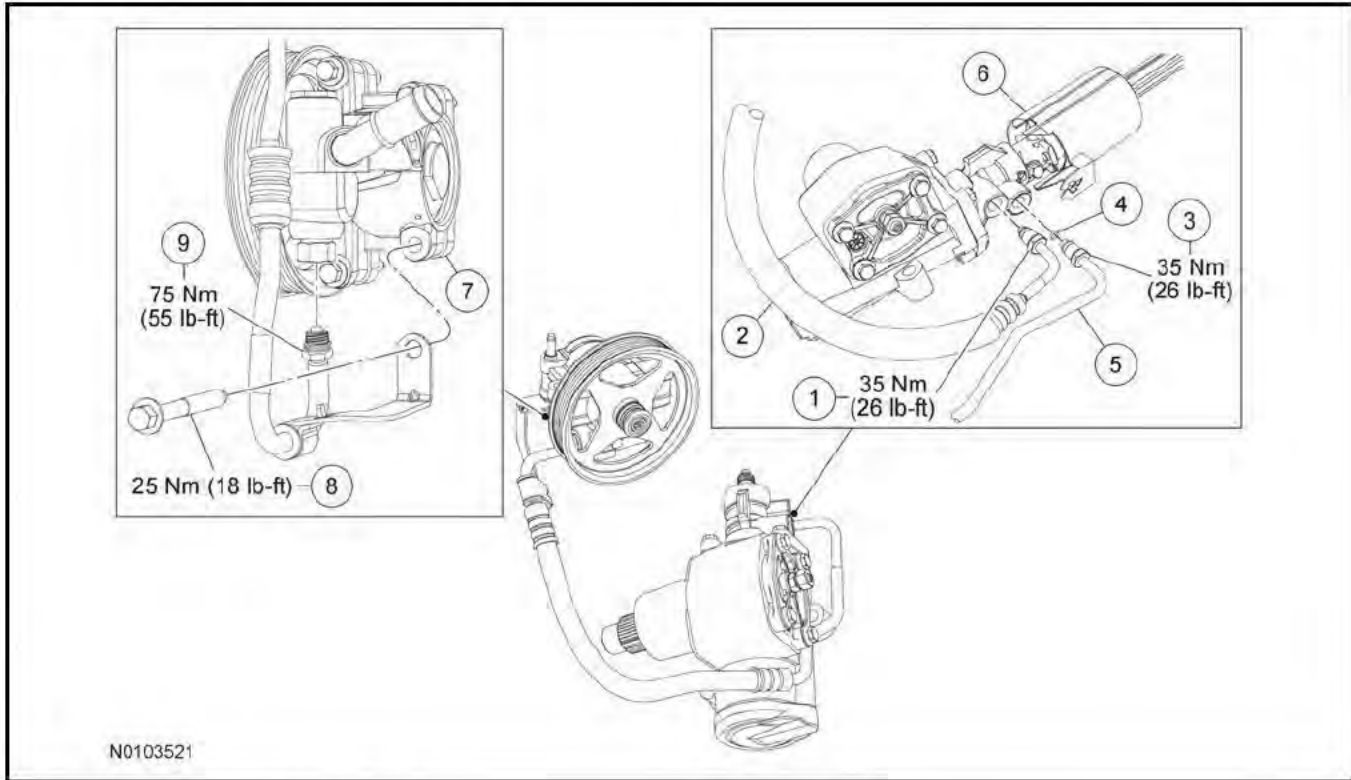

Item	Part Number	Description
1		Pressure line to steering gear fitting (part of 3A719)
2	3A719	Power steering pump to steering gear pressure line
3		Return hose to steering gear fitting (part of 3A713)
4	N803257	O ring seal
5	3A713	Return hose
6	3F450	Steering gear shield
7	3A674	Power steering pump
8	W701526	Pressure line bracket/pump bolt
9		Pressure line to pump fitting (part of 3A719)

Removal and Installation

NOTICE:

While repairing the power steering system, care should be taken to prevent the entry of foreign material or failure of the power steering components may result.

1. Using a suitable suction device, drain the power steering fluid reservoir.
2. With the vehicle in NEUTRAL, position it on a hoist. For additional information, refer to Section 100 02.
3. Remove the pressure line bracket/pump bolt.
 - To install, tighten to 25 Nm (18 lb ft).
4. Disconnect the pressure line to pump fitting.
 - To install, tighten to 75 Nm (55 lb ft).

PE13-014

FORD

7/10/2013

Appendix O

Warranty Excerpt

pressure sensor (6.4L), high pressure oil regulator, exhaust back pressure regulator and sensor, exhaust pressure sensor (6.4L), manifold pressure sensor (6.4L), intake air temperature sensor (6.4L), crankshaft position sensor (6.4L), camshaft position sensor, accelerator switch.

NOTE: Some components may also be covered by the Emissions Warranties. For more information, see pages 17-32.

Expedition Limousine Limited Warranty

If you have purchased or leased a 2008-model Expedition EL (equipped with the 17L Builder's Package) converted into a limousine by a Ford Qualified Vehicle Modifier, your Expedition EL is eligible for the Ford Limousine Limited Warranty coverage for three years or 100,000 miles, whichever occurs first. This coverage begins on the Warranty Start Date and is in addition to the New Vehicle Limited Warranty. Refer to the warranty addendum card that was given to you when you took delivery of your 2008-model Expedition EL Limousine for details of the Ford Limousine Limited Warranty. See page 38 for additional details about the 17L Limousine Builder Package.

WHAT IS NOT COVERED UNDER THE NEW VEHICLE LIMITED WARRANTY?

Damage Caused By:

- accidents, collision or objects striking the vehicle (including driving through a car wash)
- theft, vandalism, or riot
- fire or explosion
- using contaminated or improper fuel/fluids
- customer-applied chemicals or accidental spills
- driving through water deep enough to cause water to be ingested into the engine
- misuse of the vehicle, such as driving over curbs, overloading, racing or using the vehicle as a permanent stationary power source

Damage Caused by Alteration or Modification

The New Vehicle Limited Warranty does not cover any damage caused by:

- alterations or modifications of the vehicle, including the body, chassis, or components, after the vehicle leaves the control of Ford Motor Company
- tampering with the vehicle, tampering with the emissions systems or with the other parts that affect these systems (for example, but not limited to exhaust and intake systems)
- the installation or use of a non-Ford Motor Company part (other than a certified emissions part) or any part (Ford or non-Ford) designed for off-road use only installed after the vehicle leaves the control of Ford Motor Company, if the installed part fails or causes a Ford part to fail. Examples include, but are not limited to lift kits, oversized tires, roll bars, cellular phones, alarm systems, automatic starting systems and performance-enhancing powertrain components or software and performance “chips”

Damage Caused by Use and/or the Environment

The New Vehicle Limited Warranty does not cover surface rust, deterioration and damage of paint, trim, upholstery, and other appearance items that result from use and/or exposure to the elements. You, as the owner, are responsible for these items. Some examples are:

- dings, dents
- cuts, burns, punctures or tears
- road salt
- tree sap, bird and bee droppings
- windstorm, lightning, hail
- earthquake
- freezing, water or flood
- stone chips, scratches (some examples are on paint and glass)
- windshield stress cracks. However, limited coverage on windshield stress cracks will be provided for the first 12 months in service, regardless of miles driven, even though caused by use and/or exposure to the elements.