

PE12-019

MADZA

9/6/2012

APPENDIX 11

DEALER

COMMUNICATIONS

2704L

2002-2004 Tribute Accelerator  
Cable Recall 2704L

## Howell, Rosa (NHTSA)

---

**From:** Technical Services Department  
**Sent:** Wednesday, January 19, 2005 5:41 PM  
**Subject:** 2002-2004 Tribute Accelerator Cable Recall 2704L

### Attention Mazda Service and Parts Managers:

This is to notify you of an upcoming recall on certain 2002-2004 Tribute vehicles.

You will receive detailed information the week of January 24.

### Mazda will notify U.S. Tribute owners by first class mail beginning January 28, 2005.

Mazda Motor Corporation has decided that a defect, which relates to motor vehicle safety, exists in certain 2002-2004 Tribute vehicles produced from May 30, 2001 through December 19, 2003.

On certain 2002-2004 Tribute vehicles equipped with 3.0L engines, the accelerator cable may prevent the throttle from returning to the idle position, possibly resulting in elevated engine speeds while driving. An unexpected increase in engine idle speed may increase stopping distance and may result in a vehicle crash without warning.

### SUBJECT VEHICLES

Model	VIN Range	Build Date Range
2002-2004 Tribute 3.0L engine	4F2*U**1*2KM00001-M66656 4F2*Z**1*3KM00001-M56713 4F2*Z**1*4KM00004-M34822	May 30, 2001 through December 19, 2003

Note: The asterisk symbol "\*" can be any letter or number.

### PARTS INFORMATION

Description	Part Number	Quantity	
Accelerator Cable	EC05-41-660F	1	
Authorized Modification Label	9999-95-065A-00	1= sheet of 18 labels	Mstore (no charge)

### PARTS ORDERING

Dealers will automatically receive a quantity of Accelerator Cables based on the number of 2002-2004 Tribute vehicles registered in the dealer's vicinity. Parts shipments will begin 1/19/05 and will arrive on dealers' next stock order. Dealers will receive Accelerator Cables by 1/28/05

If dealers need additional Accelerator Cables after receiving the initial parts shipment, they can be ordered through the normal eMDCS parts order method after 1/29/05.

**NOTE: To assure all dealers can get parts when needed, we may require an IPFAX form in the future if PDC inventory becomes low.**

### Existing Service Parts Inventory

**Please return any inventory you have of EC05-41-660, EC05-41-660D and EC05-41-660E on your next obsolescence return and you will receive credit on your next parts statement. The return of these parts will not go against your obsolescence accrual.**

Use MStore to order additional Campaign labels (1= sheet of 18 labels).

### WARRANTY CLAIM PROCESSING INFORMATION

Warranty Type Code	R
Symptom Code	99
Damage Code	99
Process Number	J0501A
Part Number Main Cause	EC05-41-660F
Quantity	1
Labor Operation Code	YY373XRX
Labor Hours	0.4

### RENTAL CAR

A rental car may be provided to the customer if eligible based on the terms and conditions of the Rental Car Reimbursement Program, policy 12.0. Rental car reimbursements are available only on 2001 and newer vehicles within the mileage and time limitations under the New Vehicle Limited Warranty. If the customer was placed in a rental car while the campaign was being completed and the vehicle is not within the mileage and time limitations, you must obtain authorization for the rental. Submit a separate **claim/problem** using the standard rental claim information.

Warranty Type Code	A
Symptom Code	99
Damage Code	99
Part Number Main Cause	5555-RE-NTAL
Part Quantity	<b>0</b>
Labor Operation Code	MM012XRX
Labor Hours	0.0
Sublet – Rental Car	
Sublet Invoice Number	Number from Rental Invoice or Dealer Purchase Order
Sublet Type Code	Enter “L”
Sublet Amount	Up to \$26.00 per day for the number of days customer had rental car

Rental expenses that exceed the two-day limit will require prior DCSM Authorization, as outlined in the Rental Car Reimbursement Program policy.

### REPAIR PROCEDURES

Inspection and repair procedures are available on the ESI website, on MStore under Bulletins, Forms & E-Documents, and are available on eMDCS using Campaign Inquiry or the Warranty Vehicle Inquiry Detail screen by clicking on the recall number.

Please make certain that the appropriate personnel in your dealership are aware of these resources and are familiar with the details of this recall before responding to customer inquiries.

We apologize for any inconvenience this recall may cause you and your customers. Your understanding and support in carrying out this campaign is greatly appreciated.

## **Mazda Technical Services**

PE12-019

MADZA

9/6/2012

APPENDIX 11

DEALER

COMMUNICATIONS

2704L

2704L\_Original



Recall Start January 2005

**2002-2004 Tribute  
Accelerator Cable  
Safety Recall [2704L]**

**TO:** All **Mazda** Dealers  
**ATTENTION:** All General Managers, Service Managers, and Parts Managers  
**SUBJECT:** **2002 - 2004 Tribute  
Accelerator Cable Recall 2704L**

Dear **Mazda** Dealer:

**Mazda Motor Corporation** has decided that a defect, which relates to motor vehicle safety, exists in certain 2002-2004 Tribute vehicles produced from May 30, 2001 through December 19, 2003.

On certain 2002-2004 Tribute vehicles equipped with 3.0L engines, the accelerator cable may prevent the throttle from returning to the idle position, possibly resulting in elevated engine speeds while driving. An unexpected increase in engine idle speed may increase stopping distance and may result in a vehicle crash without warning.

**Owners of affected vehicles will be notified by first class mail beginning **January 28, 2005.****

This package contains important information about recall campaign **2704L**:

Attachment I	Dealer Service and Parts information
Attachment II	Inspection and Repair procedures

**The National Traffic and Motor Vehicle Safety Act prohibits selling or leasing any subject vehicles without performing the necessary repair for defects or failures. Failure to perform applicable recalls before sale can result in extensive fines and penalties from the Federal Government. Therefore, you must complete this recall for all affected new vehicles in your inventory prior to sale or lease.**

To help you effectively perform this recall, Mazda has developed the following resources:

1. Service and Parts recall instructions were e-mailed to your Service Department, and are also available on the **ESI/MS3** website, and **eMDCS**.
2. Inspection and repair procedures follow (Attachment II), are also available on the **ESI/MS3** website, and **eMDCS**
3. We recommend using the report of registered owners in the dealer's area and the quarterly "**Recall Reminder Report**" to encourage customers to come in for the recall (with recall reminder postcards, for example). Dealers may use such owner information for the sole purpose of conducting and performing this safety recall, and for no other purpose. **Using it for marketing activities is strictly prohibited and could subject your dealership to serious fines.** The information in this report is protected by state privacy and other applicable laws regarding disclosure of personal and/or confidential, restricted or blocked

information. It is the dealer's responsibility to protect the confidentiality of owner records and prevent the release of information to other parties.

In **California**, privacy laws prevent the release of names and addresses on this report.

4. For repair authorization/technical assistance and parts ordering, call the **Technical Assistance Hotline at (877) 832-8477**.
5. For warranty questions, contact the **Mazda Corporate Dealer Assistance Group at (877) 727-6626. Select Option 2**.

Please make certain that the appropriate personnel in your dealership are aware of these resources and are familiar with the details of this recall before responding to customer inquiries.

A rental car may be provided to the customer, if eligible, based on the terms and conditions of the Rental Car Reimbursement Program, policy 12.0. Rental car reimbursements are available only on 2001 and newer vehicles within the mileage and time limitations under the New Vehicle Limited Warranty.

We apologize for any inconvenience this program may cause you and your personnel. Your understanding and support in carrying out this campaign is greatly appreciated.

Sincerely,

**MAZDA NORTH AMERICAN OPERATIONS**

**CONDITION OF CONCERN**

On certain 2002-2004 Tribute vehicles equipped with 3.0-liter engines, the accelerator cable may prevent the throttle from returning to the idle position, possibly resulting in elevated engine speeds while driving. An unexpected increase in engine idle speed may increase stopping distance and may result in a vehicle crash without warning.

**SUBJECT VEHICLES**

Model	VIN Range	Build Date Range
Tribute 3.0L engine 2002	4F2BU**1*2K [REDACTED] 4F2BU**1*2K M6 4F2CU**1*2K [REDACTED] 4F2CU**1*2K M6 4F2UU**1*2K [REDACTED] 4F2UU**1*2K M6 4F2YU**1*2K [REDACTED] 4F2YU**1*2K M6	May 30, 2001 through December 19, 2003
2003	4F2CZ**1*3K [REDACTED] 4F2CZ**1*3K M5 4F2YZ**1*3K [REDACTED] 4F2YZ**1*3K M5	
2004	4F2CZ**1*4K [REDACTED] 4F2CZ**1*4K M3 4F2CZ**1*4K [REDACTED] 4F2CZ**1*4K M3	

**Note:** The asterisk symbol "\*" can be any letter or number

**Please perform a Warranty Vehicle Inquiry using eMDCS to determine if this vehicle needs the recall performed.**

**OWNER NOTIFICATION**

Owners of affected vehicles will be notified by mail on January 28, 2005.

**PARTS INFORMATION**

Description	Part Number	Quantity	
Accelerator Cable	EC05-41-660F	1	
Blue Campaign Label	9999-95-065A-00	1= sheet of 18 labels	Mstore (no charge)

**PARTS ORDERING**

Dealers will automatically receive a quantity of Accelerator Cables based on the number of 2002-2004 Tribute vehicles registered in the dealer's vicinity. Parts shipments will begin 1/19/05 and will arrive on dealers' next stock order. Dealers will receive Accelerator Cables by 1/28/05

If dealers need additional Accelerator Cables after receiving the initial parts shipment, they can be ordered through the normal eMDCS parts order method after 1/29/05. **NOTE: To assure all dealers can get parts when needed, we may require an IPFAX form in the future if PDC inventory becomes low.**

**Existing Service Parts Inventory**

Please return any inventory you have of **EC05-41-660**, **EC05-41-660D** and **EC05-41-660E** on your next obsolescence return and you will receive credit on your next parts statement. The return of these parts will not go against your obsolescence accrual.

Use **MStore** to order additional PCM Calibration Labels, *Vehicle Emission Recall - Proof of Correction* certificates (50 certificates per package) and Campaign Labels (8 ½" X 11" sheets containing 18 labels).

**WARRANTY INFORMATION**

	Accelerator Cable Replacement
Warranty Type Code	R
Symptom Code	99
Damage Code	99

Process Number	J0501A
Part Number Main Cause	EC05-41-660F
Quantity	1
Labor Operation Code	YY373XRX
Labor Hours	0.4

### RENTAL CAR

A rental car may be provided to the customer, if eligible, based on the terms and conditions of the Rental Car Reimbursement Program, policy 12.0. Rental car reimbursements are available only on 2001 and newer vehicles within the mileage and time limitations under the New Vehicle Limited Warranty. If the customer was placed in a rental car while the campaign was being completed, add a sublet to the claim using the information below.

**Rental claims** for vehicles beyond the New Vehicle Limited Warranty require **DSA** or **DCSM Authorization**.

#### Sublet – Rental Car:

	Rental Car
Warranty Type Code	A
Symptom Code	99
Damage Code	99
Part Number Main Cause	5555-RE-NTAL
Part Quantity	0
Labor Operation Code	MM012XRX
Labor Hours	0.0
Sublet – Rental Car	
Sublet Invoice Number	Number from Rental Invoice or Dealer Purchase Order
Sublet Type Code	Enter "L"
Sublet Amount	Up to <b>\$30.00</b> per day for the number of days customer had rental car

**Rental expenses** that exceed the two-day limit will require **DSA** or prior **DCSM Authorization**, as outlined in the Rental Car Reimbursement Program Policy.

<i>For Internal Use Only</i>	<i>Call Log Number #</i>
------------------------------	--------------------------

**CORPORATE DEALER ASSISTANCE GROUP**

**IPFAX Order Form**

**Recall 2704L: 2002-2004 Tribute (3.0-liter)**

**Throttle Accelerator Cable**

**Send to FAX #: 866-366-2061**

- Please ensure your fax machine has been programmed to display your return fax number at the top
- All requests will be processed in the order they are received
- A VIN is required and the part request must be for a vehicle with a damaged hose

DATE: \_\_\_\_\_ Dealer Code: \_\_\_\_\_ Dealer Name: \_\_\_\_\_

Requester First and Last Name: \_\_\_\_\_

Dealer Fax: \_\_\_\_\_ Dealer Phone: \_\_\_\_\_

Dealer Sales Order Number: \_\_\_\_\_

VIN: \_\_\_\_\_

**Max Quantity 1 part /VIN:**

**EC05-41-660F Accelerator Cable** QTY:   1  

Comments: \_\_\_\_\_  
 \_\_\_\_\_  
 \_\_\_\_\_  
 \_\_\_\_\_

**As your normal fax confirmation is not a guarantee that your request has been received, the Dealer Assistance Group will send a separate confirmation back to the dealer fax listed above; if you do not receive our confirmation sheet within the next business day, please refax your request to us.**

2002 - 2004 TRIBUTE ACCELERATOR CABLE [RECALL 2704L]

**A. VEHICLE INSPECTION PROCEDURE**

1. Verify the vehicle is within the following ranges:
  - 2002-2004 Tribute vehicles equipped with 3.0L engine built between May 30, 2001 through December 19, 2003.

VIN Ranges:

2002 Tribute 4F2\*U\*\* 1\* 2K [REDACTED] 4F2\*U\*\* 1\* 2K M6 [REDACTED]

2003 Tribute 4F2\*Z\*\* 1\* 3K M [REDACTED] 4F2\*Z\*\* 1\* 3K M5 [REDACTED]

2004 Tribute 4F2\*Z\*\* 1\* 4K M [REDACTED] 4F2\*Z\*\* 1\* 4K M3 [REDACTED]

  - If the vehicle is within one of the above ranges, proceed to step 2.
  - If the vehicle is not within one of the above ranges, return vehicle to the customer or inventory.
2. Perform a Warranty Vehicle Inquiry using your eMDCS System and inspect vehicle for an Authorized Modification Label **Recall 2704L** attached to the vehicle's hood. Refer to eMDCS System - Warranty Vehicle Inquiry Results table below.

**NOTE:** Be sure to verify RECALL number as the vehicle may have multiple Recall labels.

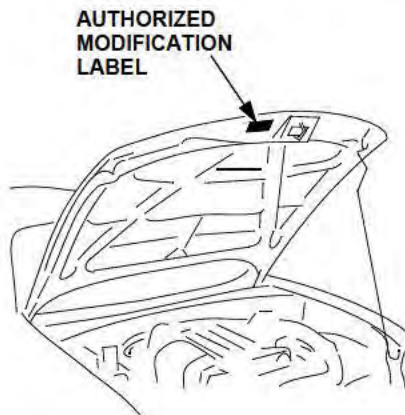

**eMDCS System - Warranty Vehicle Inquiry Results:**

If eMDCS displays:	Campaign Label is:	Action to perform:
RECALL 2704L OPEN	Present	Contact the Mazda Corporate Dealer Assistance Group at (877) 727-6626 to update vehicle history.
	Not present	Proceed to "B. REPAIR PROCEDURE".
RECALL 2704L CLOSED	Present	Return vehicle to inventory or customer.
	Not present	Complete a label and apply to vehicle's hood.
RECALL 2704L is not displayed	Does not apply	Recall does not apply to this vehicle. Return vehicle to inventory or customer.

## B. REPAIR PROCEDURE

### REMOVAL

1. From inside the vehicle, disconnect the accelerator cable from the pedal.
  - a. Remove the rubber plunger from the accelerator pedal.

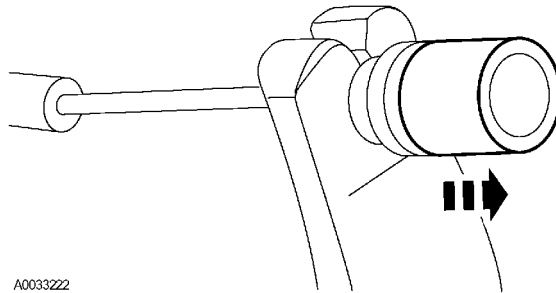

- b. Pull the plunger rearward and remove the accelerator cable from the pedal.

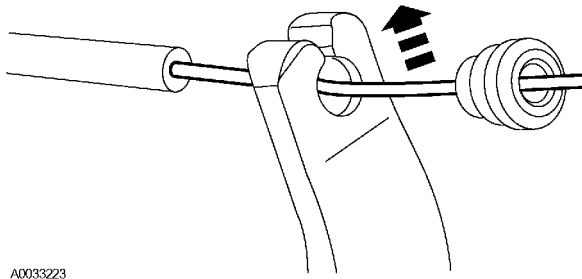

2. Remove the engine appearance cover.

3. Disconnect the accelerator cable as follows.

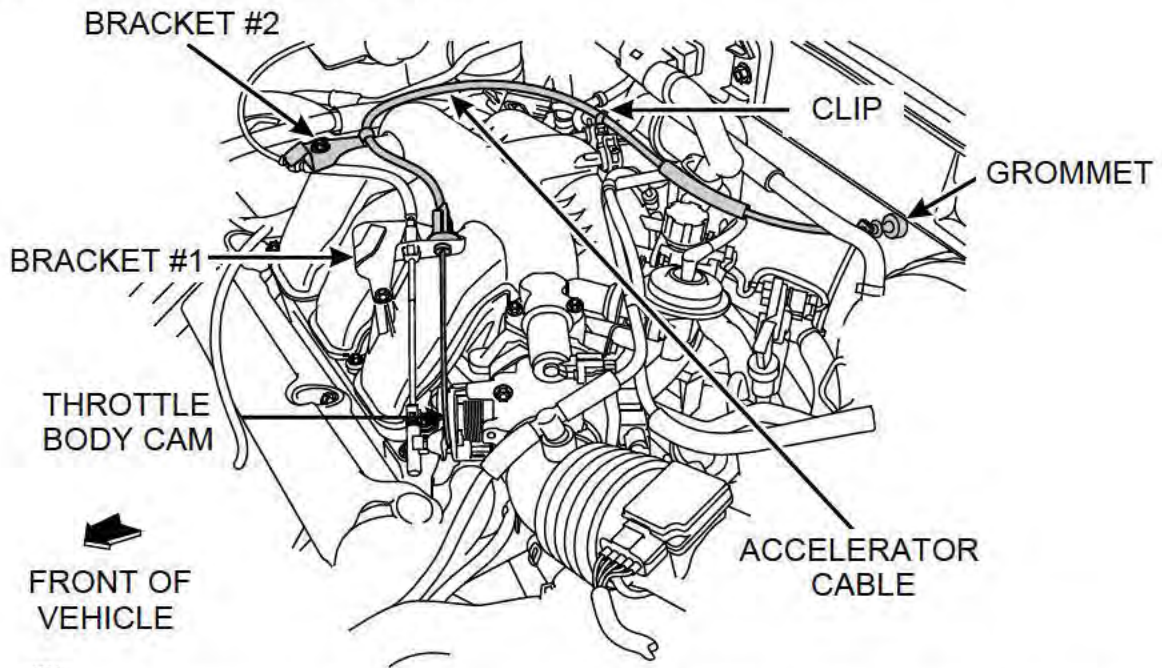

1001a

- a. Disconnect the cable by rotating the throttle body cam and sliding the cable barrel out of the cam.
- b. Remove the accelerator cable from bracket #1 by turning the cable housing 45 degrees either way and pulling it from the bracket.
- c. Open bracket #2 with a screwdriver and remove the accelerator cable from the bracket.

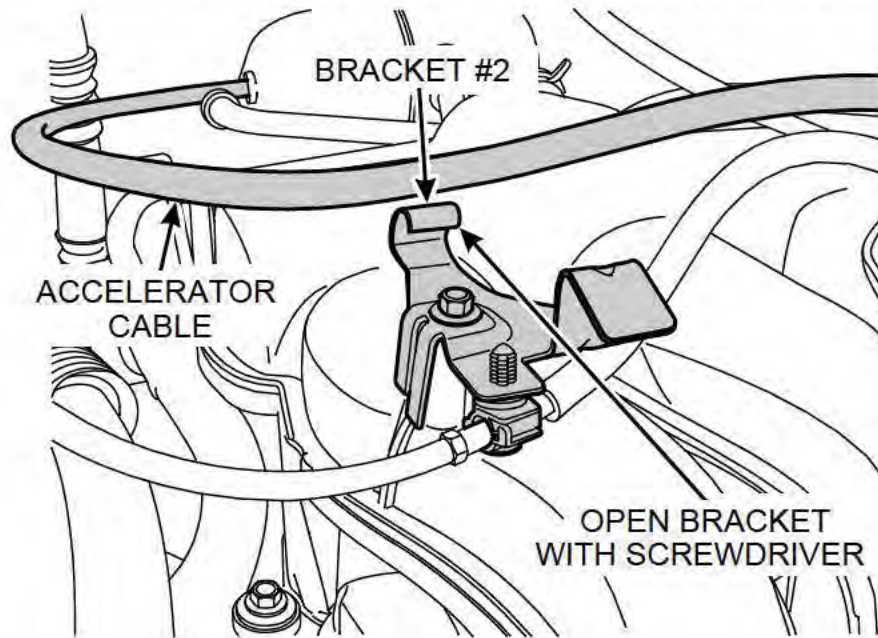

1001b

- d. Detach the accelerator cable from the clip located on the brake booster vacuum hose.
- e. Disengage the grommet at the dash panel and remove the accelerator cable from the vehicle.

**INSTALLATION**

1. Feed the new cable through the dash panel and fully seat the grommet.
2. Install and connect the accelerator cable as follows.

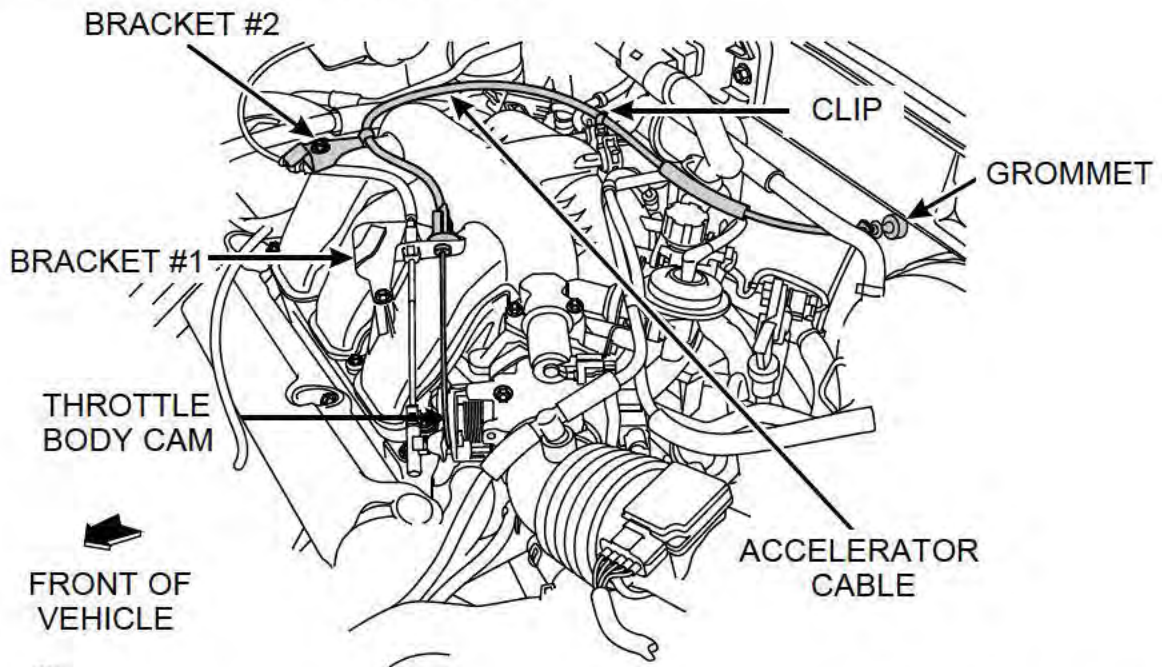

1001a

- a. Connect the cable to the throttle body by rotating the cam and sliding the cable barrel into the cam.
- b. Attach the accelerator cable to the clip located on the brake booster vacuum hose.
- c. Secure the accelerator cable to the bracket #1 by inserting it and rotating the cable housing 45 degrees to lock it in place.
- d. Position the accelerator cable in bracket #2 and, using a suitable tool, bend down the tab to retain the cable while ensuring the cable moves freely in the bracket.

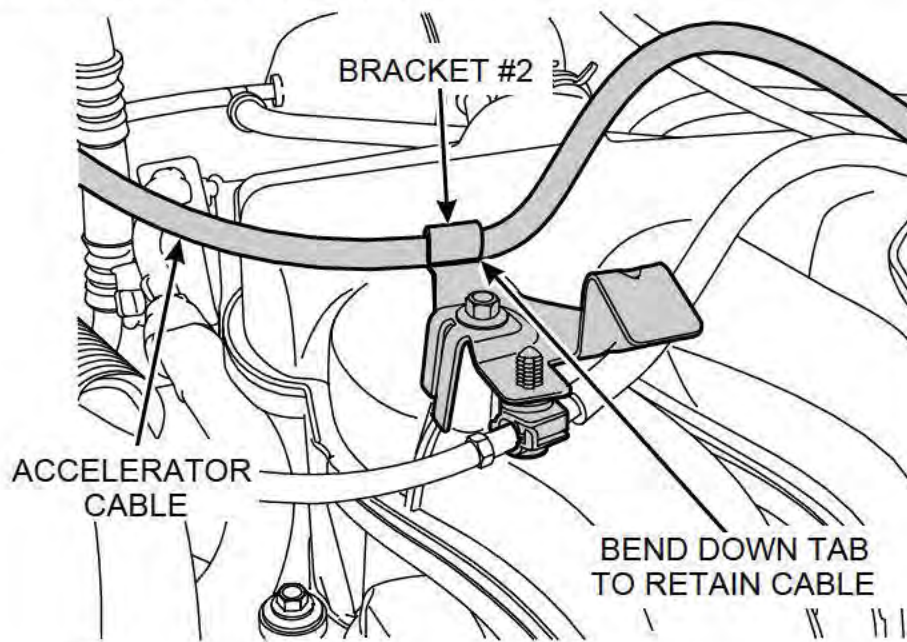

1001c

3. Connect the accelerator cable to the pedal.
  - a. Position the plunger rearward and install the accelerator cable into the pedal.

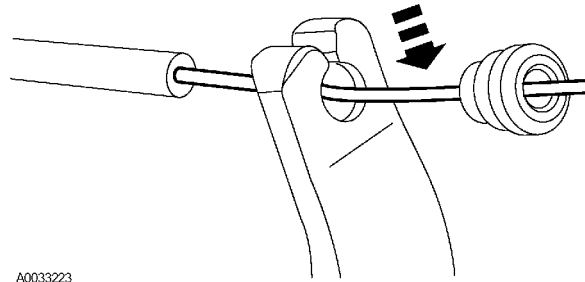

A0033223

- b. Install the rubber plunger ensuring the plunger is seated properly.

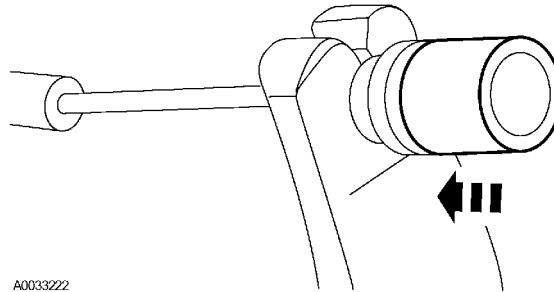

A0033222

4. Install the appearance cover.
5. Check for free movement of the accelerator pedal and that there is no binding.

### **C. AUTHORIZED MODIFICATION LABEL INSTALLATION**

Complete an "Authorized Modification Label" with the Recall number written on the sticker and affix it to the vehicle's hood. Refer back to the illustration under "A. VEHICLE INSPECTION PROCEDURE".

PE12-019

MADZA

9/6/2012

APPENDIX 11

DEALER

COMMUNICATIONS

2704L

2704L\_Update



**TO:** All Mazda Dealership General Managers, Service Managers, and Parts Managers  
**DATE:** July 2012  
**SUBJECT:** 2002-2004 Tribute Accelerator Cable Safety Recall 2704L – **UPDATE**

**IMPORTANT UPDATE:**

**A CAUTION has been added to the Repair Procedure (Attachment II) to help prevent damage to the speed control cable while performing the accelerator cable replacement procedure.**

Mazda Motor Corporation has decided that a defect which relates to motor vehicle safety exists in certain 2002-2004 Tribute vehicles produced from May 30, 2001 through December 19, 2003.

On certain 2002-2004 Tribute vehicles equipped with 3.0L engines, the accelerator cable may prevent the throttle from returning to the idle position, possibly resulting in elevated engine speeds while driving. An unexpected increase in engine idle speed may increase stopping distance and may result in a vehicle crash without warning.

Owners of affected vehicles were notified by first class mail on January 28, 2005.

This package contains important information about Safety Recall 2704L:

Attachment I	Dealer Parts and Service Information
Attachment II	Inspection and Repair Procedures

The National Traffic and Motor Vehicle Safety Act prohibits selling or leasing any subject vehicle without performing the necessary repair for defects or failures. Failure to perform applicable recalls before sales can result in extensive fines and penalties from the Federal Government. Therefore, you must complete this recall for all affected vehicles in your inventory prior to sale or lease.



-Page 2-

To help you effectively perform this recall, Mazda has developed the following resources:

1. Service and Parts recall instructions were emailed to your Service Department, and are also available on eMDCS and MS3 (Mazda Service Support System) via MXConnect.
2. Inspection and repair procedures follow (Attachment II), and are also available on eMDCS and MS3 (Mazda Service Support System) via MXConnect.
3. We recommend using the Recall Reminder Report available in Web Reporting to encourage customers to come in for the recall (with recall reminder postcards). Dealers may use such owner information for the sole purpose of conducting and performing this recall, and for no other purpose. **Using it for marketing activities is strictly prohibited and could subject your dealership to serious fines.** The information in the report is protected by state privacy and other applicable laws regarding disclosure of personal and/or confidential, restricted or blocked information. It is the dealer's responsibility to protect the confidentiality of owner records and prevent the release of information to other parties.
4. For repair authorization/technical assistance, call the Technical Assistance Hotline at (888) 832-8477, Option 3 for English speaking Hotline Specialist, Option 4 for Spanish speaking Hotline Specialist.
5. For warranty questions, contact the Warranty Hotline at (877) 727-6626, Option 3.
6. For parts questions, contact the Corporate Dealer Assistance Group at (877) 727-6626, Option 2.

Please make certain the appropriate personnel in your dealership are aware of these resources and are familiar with the details of this recall before responding to customer inquiries.

A rental car may be provided to the customer, if eligible, based on the terms and conditions of the Rental Car Reimbursement Program, Section 12.0. Rental car reimbursement are available only on 2001 and newer vehicles within the mileage and time limitations under the New Vehicle Limited Warranty.

We apologize for any inconvenience this recall may cause you and your customers. Your understanding and support in carrying out this campaign is greatly appreciated.

Sincerely,

Mazda North American Operations

**ATTACHMENT I –PARTS AND SERVICE INFORMATION**  
**Safety Recall 2704L**

**CONDITION OF CONCERN**

On certain 2002-2004 Tribute vehicles equipped with 3.0L engines, the accelerator cable may prevent the throttle from returning to the idle position, possibly resulting in elevated engine speeds while driving. An unexpected increase in engine idle speed may increase stopping distance and may result in a vehicle crash without warning.

**SUBJECT VEHICLES**

Model	VIN Range	Build Date Range
Tribute 3.0L engine:		
2002 model year	4F2BU**1*2 [REDACTED] - 4F2BU**1*2K M 4F2CU**1*2 [REDACTED] - 4F2CU**1*2K M 4F2UU**1*2 [REDACTED] - 4F2UU**1*2K M 4F2YU**1*2 [REDACTED] - 4F2YU**1*2K M	May 30, 2001 through December 19, 2003
2003 model year	4F2CZ**1*3 [REDACTED] - 4F2CZ**1*3K M 4F2YZ**1*3 [REDACTED] - 4F2YZ**1*3K M	
2004 model year	4F2CZ**1*4 [REDACTED] - 4F2CZ**1*4K M 4F2CZ**1*4 [REDACTED] - 4F2CZ**1*4K M	

Note: The asterisk symbol “\*” can be any letter or number.

Please perform a Warranty Vehicle Inquiry using eMDCS to determine if this vehicle needs the recall performed.

**OWNER NOTIFICATION**

Owners of affected vehicles were notified by first class mail on January 28, 2005.

**PARTS INFORMATION**

Description	Part Number	Quantity	Notes
Accelerator Cable	EC05-41-660F	1	
Campaign Label	9999-95-065A-06	1=50 labels	Obtain in MStore (no charge)

**PARTS ORDERING**

Dealers automatically received a quantity of Accelerator Cables based on the number of 2002-2004 Tribute vehicles registered in the dealer’s vicinity. Parts shipments began 1/19/05 and arrived on the dealers’ next stock order. Dealers received the Accelerator Cables by 1/28/05.

**Existing Service Parts Inventory**

Please return any inventory you have of EC-05-41-660, EC05-41-660D and EC05-41-660E on your next obsolescence return and you will receive credit on your next parts statement. The return of these parts will not go against your obsolescence accrual.

**WARRANTY CLAIM PROCESSING INFORMATION**

	Accelerator Cable Replacement
Warranty Type	<b>R</b>
Symptom Code	99
Damage Code	99
Process Number	<b>J0501A</b>
Part Number Main Cause	EC05-41-660F
Quantity	1
Labor Operation Number	YY373XRX
Labor Hours	0.4 hrs

**RENTAL CAR**

A rental car may be provided to the customer, if eligible, based on the terms and conditions of the Rental Car Reimbursement Program, Section 12.0. Rental car reimbursements are available only on 2001 and newer vehicles within the mileage and time limitations under the New Vehicle Limited Warranty. If the customer was placed in a rental car while the campaign was being completed, add a sublet to the claim using the information below.

Rental claims for vehicles beyond the New Vehicle Limited Warranty require DSA and DCSM Authorization.

**Sublet – Rental Car:**

	Rental Car
Warranty Type Code	A
Symptom Code	99
Damage Code	99
Part Number Main Cause	5555-RE-NTAL
Part Quantity	0
Labor Operation Code	MM012XRX
Labor Hours	0.0
Sublet – Rental Car	
Sublet Invoice Number	Number from rental invoice or dealer purchase order
Sublet Type Code	Enter "L"
Sublet Amount	Up to \$30 per day for the number of days customer had rental car

Rental expenses that exceed the two-day limit with require DSA or prior DCSM Authorization, as outlined in the Rental Car Reimbursement Program Policy.

**A. VEHICLE INSPECTION PROCEDURE**

**IMPORTANT UPDATE:**

- A CAUTION has been added to the Repair Procedure on page 3 to help prevent damage to the speed control cable while performing the accelerator cable replacement procedure.

1. Verify the vehicle is within the following ranges:
  - 2002-2004 Tribute vehicles equipped with 3.0L engine built between May 30, 2001 through December 19, 2003.

VIN Ranges:

2002 Tribute 4F2\*U\*\* 1\* 2K M [redacted] 4F2\*U\*\* 1\* 2K M6 [redacted]  
 2003 Tribute 4F2\*Z\*\* 1\* 3K M [redacted] 4F2\*Z\*\* 1\* 3K M5 [redacted]  
 2004 Tribute 4F2\*Z\*\* 1\* 4K M [redacted] 4F2\*Z\*\* 1\* 4K M3 [redacted]

- If the vehicle is within one of the above ranges, proceed to step 2.
  - If the vehicle is not within one of the above ranges, return vehicle to the customer or inventory.
2. Perform a Warranty Vehicle Inquiry using your eMDCS System and inspect vehicle for an Authorized Modification Label **Recall 2704L** attached to the vehicle’s hood. Refer to eMDCS System - Warranty Vehicle Inquiry Results table below.

**NOTE:** Be sure to verify RECALL number as the vehicle may have multiple Recall labels.

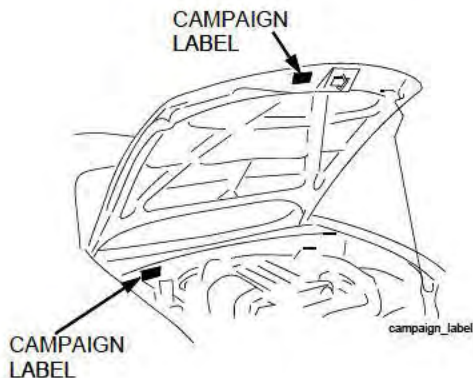

**eMDCS System - Warranty Vehicle Inquiry Results:**

If eMDCS displays:	Campaign Label is:	Action to perform:
RECALL 2704L OPEN	Present	Contact the Warranty Hotline at (877) 727-6626 option 3 to update vehicle history.
	Not present	Proceed to "B. REPAIR PROCEDURE".
RECALL 2704L CLOSED	Present	Return vehicle to inventory or customer.
	Not present	Complete a label and apply to vehicle’s hood.
RECALL 2704L is not displayed	Does not apply	Recall does not apply to this vehicle. Return vehicle to inventory or customer.

## B. REPAIR PROCEDURE

### REMOVAL

1. From inside the vehicle, disconnect the accelerator cable from the pedal.
  - a. Remove the rubber plunger from the accelerator pedal.

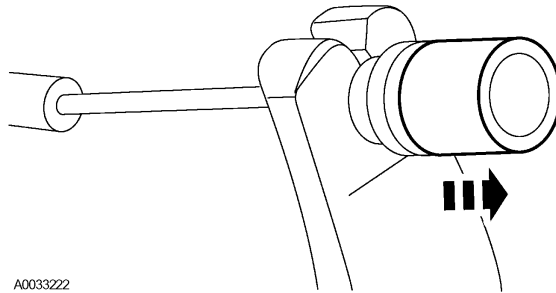

- b. Pull the plunger rearward and remove the accelerator cable from the pedal.

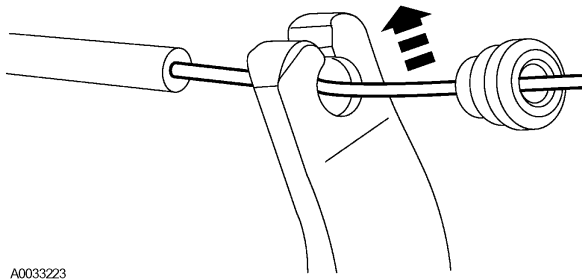

2. Remove the engine appearance cover, if equipped.

**CAUTION:** Damage to the speed control cable may result if the throttle body cam is rotated by lifting up on the speed control cable or the speed control cable connector end. When disconnecting the accelerator cable from the throttle body, rotate the throttle body cam only by lifting up on the cam itself. See Figure below.

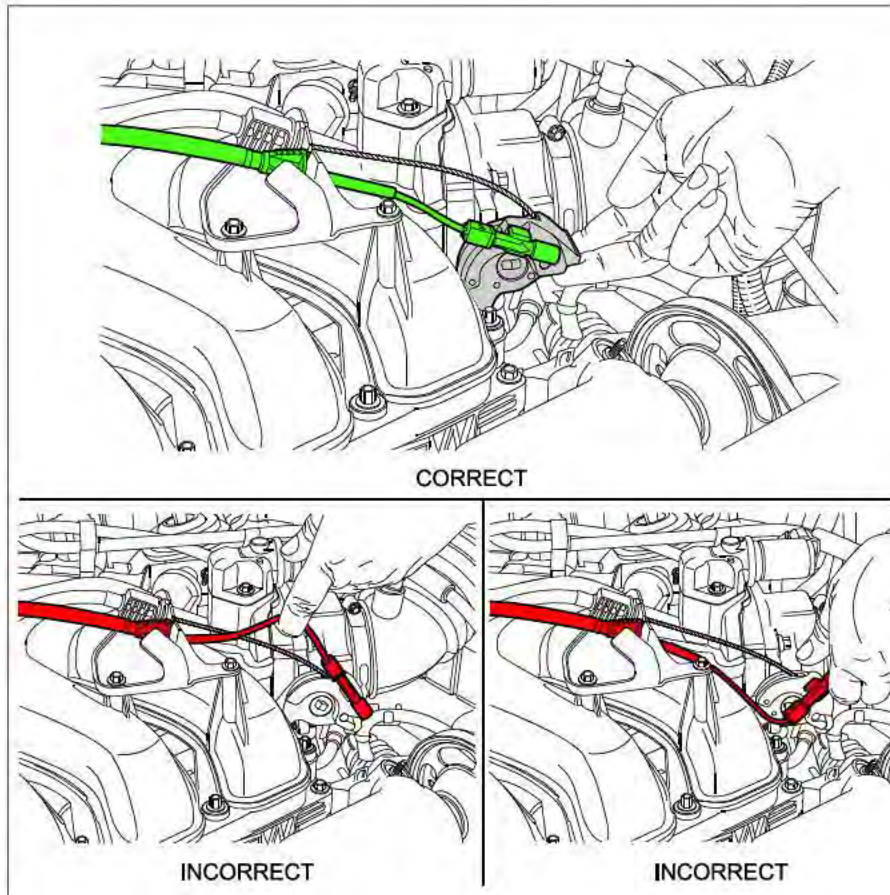

3. Disconnect the accelerator cable as follows.

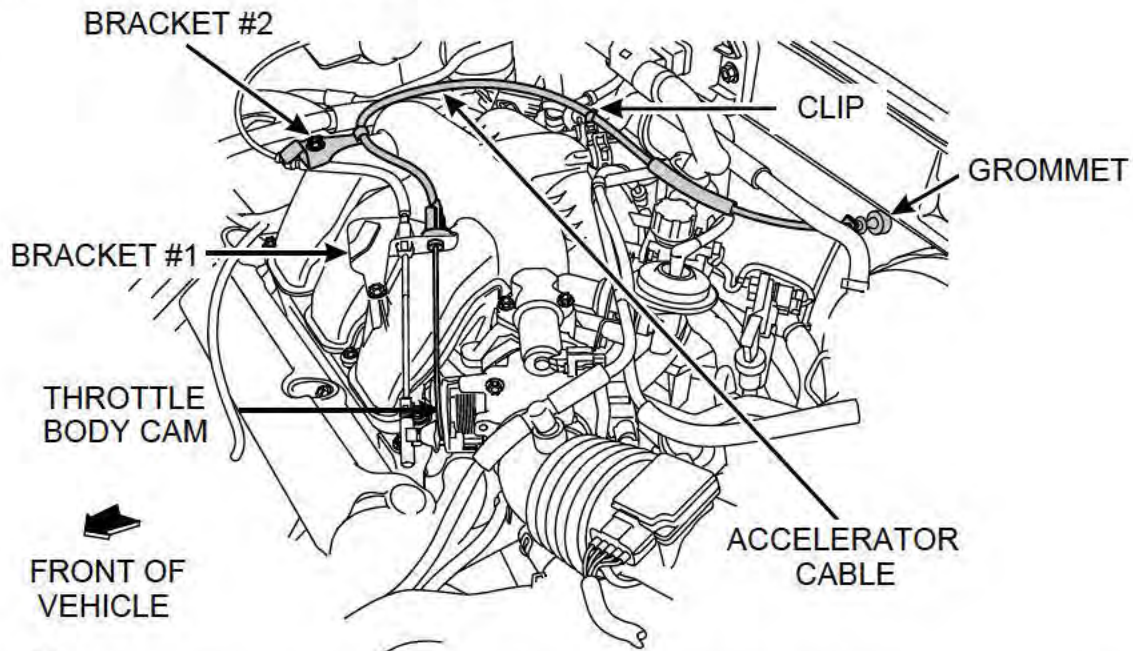

1001a

- a. Disconnect the cable by rotating the throttle body cam and sliding the cable barrel out of the cam.
- b. Remove the accelerator cable from bracket #1 by turning the cable housing 45 degrees either way and pulling it from the bracket.
- c. Open bracket #2 with a screwdriver and remove the accelerator cable from the bracket.

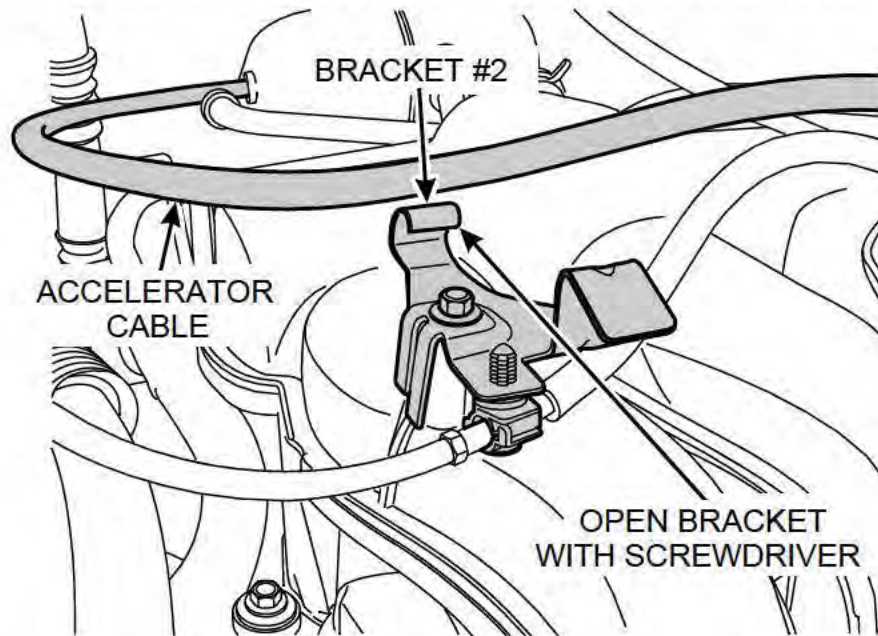

1001b

- d. Detach the accelerator cable from the clip located on the brake booster vacuum hose.
- e. Disengage the grommet at the dash panel and remove the accelerator cable from the vehicle.

**INSTALLATION**

1. Feed the new cable through the dash panel and fully seat the grommet.
2. Install and connect the accelerator cable as follows.

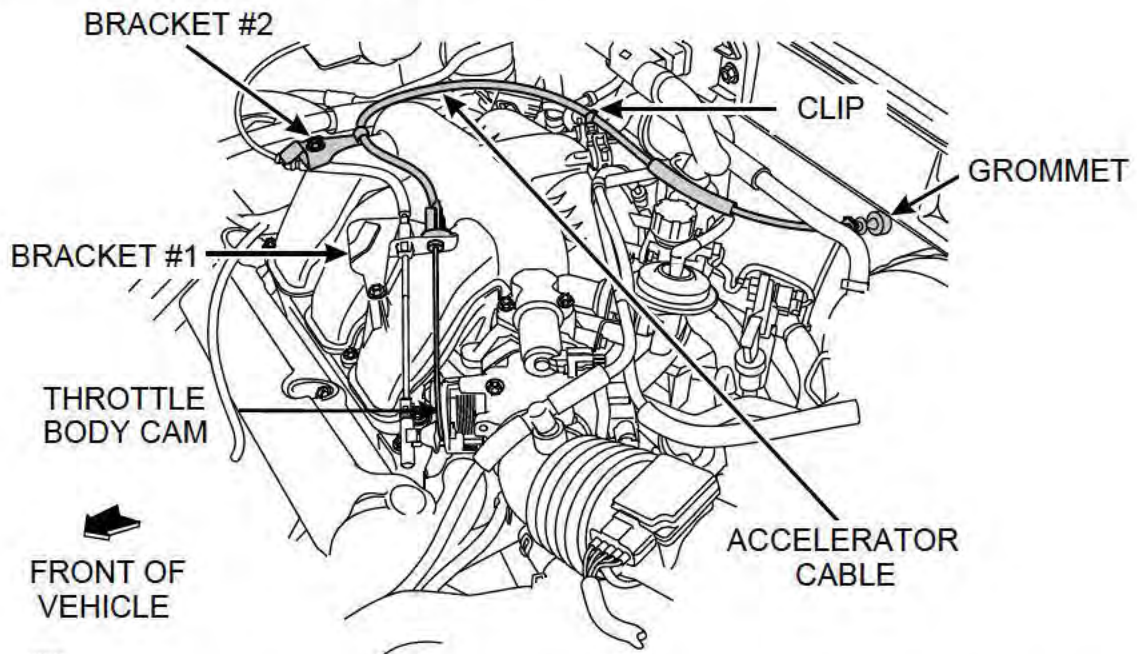

1001a

- a. Connect the cable to the throttle body by rotating the cam and sliding the cable barrel into the cam.
- b. Attach the accelerator cable to the clip located on the brake booster vacuum hose.
- c. Secure the accelerator cable to the bracket #1 by inserting it and rotating the cable housing 45 degrees to lock it in place.
- d. Position the accelerator cable in bracket #2 and, using a suitable tool, bend down the tab to retain the cable while ensuring the cable moves freely in the bracket.

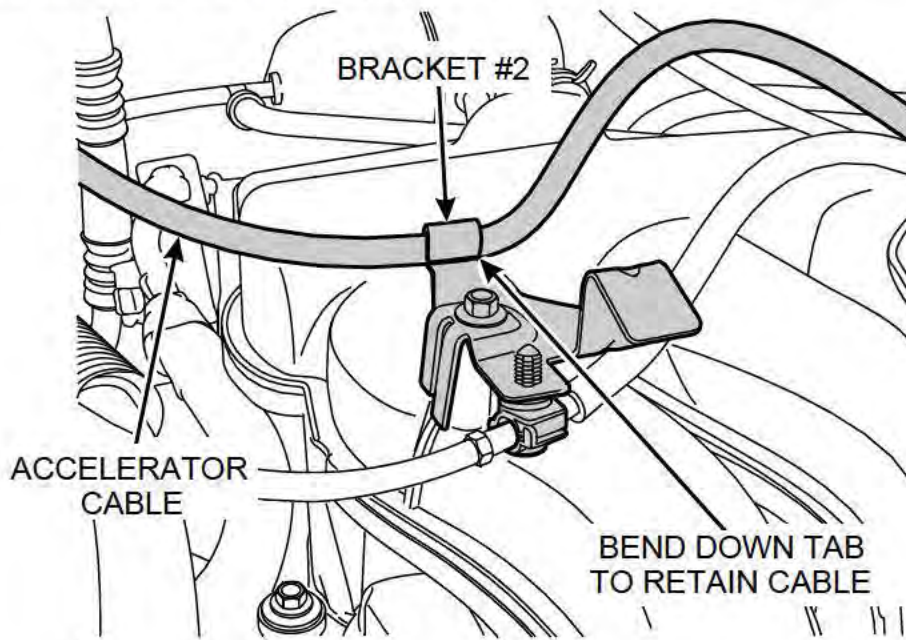

1001c

3. Connect the accelerator cable to the pedal.
  - a. Position the plunger rearward and install the accelerator cable into the pedal.

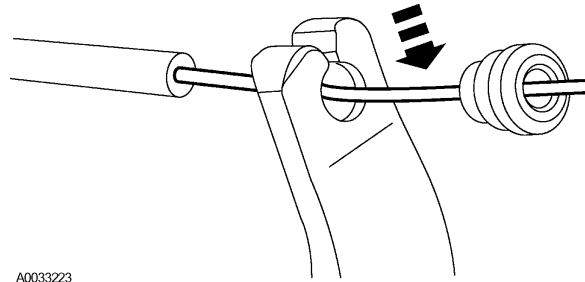

A0033223

- b. Install the rubber plunger ensuring the plunger is seated properly.

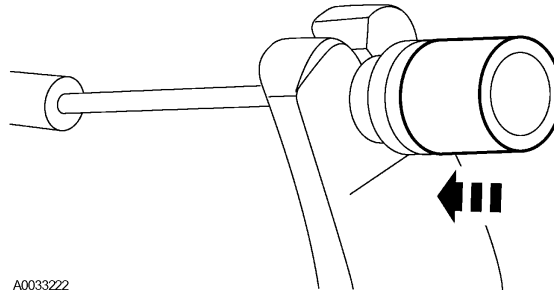

A0033222

4. Install the appearance cover.
5. Check for free movement of the accelerator pedal and that there is no binding.

### **C. AUTHORIZED MODIFICATION LABEL INSTALLATION**

Complete an "Authorized Modification Label" with the Recall number written on the sticker and affix it to the vehicle's hood. Refer back to the illustration under "A. VEHICLE INSPECTION PROCEDURE".

PE12-019

MADZA

9/6/2012

APPENDIX 11

DEALER

COMMUNICATIONS

2704L

FAQs for Updated Recall  
2704L Tribute Accelerator  
Cable repair procedure

## Howell, Rosa (NHTSA)

---

**From:** Sharon Kaplan  
**Sent:** Tuesday, July 17, 2012 7:18 PM  
**To:** All Zone CS&P Managers; Allan Wong; Beverly Braga; Brian Wietersen; Carol Robbins; Cathy Stephens; Charles Kim; Chatchai Thaosatien; Chris Patton; CJ Martin; Dan Ryan; Darrel Chin; Dave Pace; David Robertson; Denise Husak; Don Cerrina; Don MacPhee (MCI); Gaby Laur; Irene Tsao; Jerry Ward; Jillian (Gauer) Bentow; Jim Campbell; John Encheff; John Trela; Johnny Garcia; Jose Tosado; Katsuhiko Torimaru; Kazunari Takahashi; Lisa Feitz; Matt Reiter; Nathan Edmonds; Paul Topor; Paul Woolley; Pierre Hugues Comire (MCI); Ricardo A. Flores; Richard Salceda; Rob Murdoch (MCI); Ruby Ng; Ryan Matthews; Satoshi Takahashi; Sharon Kaplan; Tim Barnes; Tim Enoch; Tom Hannah; Weldon Munsey  
**Subject:** FAQs for Updated Recall 2704L Tribute Accelerator Cable repair procedure  
**Attachments:** 2704L FREQUENTLY ASKED QUESTIONS.pdf  
**Importance:** High

Please see attached FAQs **for internal use only**.

Sharon Kaplan | Regulatory Compliance, Recalls/TREAD  
Mazda North American Operations | Irvine, CA 92614  
T 949.442.6502 | [skaplan@mazdausa.com](mailto:skaplan@mazdausa.com) | [www.MazdaUSA.com](http://www.MazdaUSA.com)



**SKYACTIV** TECHNOLOGY

It's not the first 40-mpg sedan.  
It's just the first one worth driving.

2012 MAZDA3

**PRIVILEGED & CONFIDENTIAL**

This e-mail may contain privileged communications. If you have received it in error, please delete it immediately and notify the sender.

PE12-019

MADZA

9/6/2012

APPENDIX 11

DEALER

COMMUNICATIONS

2704L

Recall 2704L Update

**Howell, Rosa (NHTSA)**

---

**From:** Technical Services Division  
**Sent:** Friday, July 13, 2012 4:32 PM  
**Subject:** Recall 2704L Update  
**Attachments:** 2704L.pdf  
  
**Importance:** High



*MAZDA DEALER EMAIL*

*zoom-zoom*

*zoom-zoom*

July 13, 2012

Dear Mazda Dealer,

Safety Recall 2704L for 2002-2004 Tribute Accelerator Cable has been revised to add a CAUTION note to the repair procedure, to help prevent damage to the speed control cable while performing the accelerator cable replacement procedure.

Please refer to the attached updated 2704L dealer documents, which are also available on the Mazda Service Support System (MS3) website and on eMDCS.

Your understanding and support in carrying out this campaign are greatly appreciated.

Mazda Technical Services

PE12-019

MADZA

9/6/2012

APPENDIX 11

DEALER

COMMUNICATIONS

2704L

Safety Recall 2704L Update

**Howell, Rosa (NHTSA)**

---

**From:** Field Communications (eFC)  
**Sent:** Friday, July 13, 2012 3:40 PM  
**To:** Field Communications (eFC)  
**Subject:** Safety Recall 2704L Update  
**Attachments:** eFC-I-12-00177.pdf; eFC-I-12-00177a.pdf; eFC-I-12-00177b.pdf

**\*\*\* PLEASE DO NOT REPLY TO THIS MESSAGE \*\*\***

**Originator:** Sharon Kaplan  
**Subject:** Safety Recall 2704L Update  
**Summary:** Safety Recall 2704L for 2002-2004 Tribute Accelerator Cable has been revised to add a Caution to the repair procedure.

**This notice is Information Only**

**Click on the attached file(s) to open and review the eFC document**

PE12-019

MADZA

9/6/2012

APPENDIX 11

DEALER

COMMUNICATIONS

2704L

Second Employee Notification

Recall 2704L 2002-2004

Tribute Accelerator Cable

## Howell, Rosa (NHTSA)

---

**From:** Hazel Tippings  
**Sent:** Thursday, February 10, 2005 12:01 PM  
**To:** Jeremy Barnes; Jennie Mendel; Cyrile Dabbs; Liza Ferer; Karen Moynihan; Laurie King; Janice Manning; Melissa Rimoldi; Tony Lawrence; Don Tamaki; Michele Hutchinson; Robert Johnson; Brigit Olivero; Jorge Villarruel; Paul Carty; Mary Moloney; Robin Powe  
**Subject:** Second Employee Notification Recall 2704L 2002-2004 Tribute Accelerator Cable

On January 28, 2005 an e-mail was sent to you notifying you of a recall on your lease/demo vehicle, or vehicles (s) for which you are responsible within your department. As of today, this recall is still showing open for your vehicle(s).

Please make arrangements to have this recall completed as soon as possible.

For your information, below is the content of the original e-mail notification:

Company car records indicate your demonstrator/lease vehicle, or vehicles (s) for which you are responsible, is (are) subject to 2002-2004 Tribute Accelerator Cable Recall 2704L.

If you are an Irvine based employee, please schedule a service appointment with the MNAO Service Shop. For those employees outside the Irvine area, schedule a service appointment following the procedures in place for your location.

If you and/or your dependent(s) no longer lease or drive your Tribute, please contact your Mazda company car coordinator to update our records as soon as possible.

Please refer to the attachments for the details on these campaigns.

Your understanding and support in carrying out this program is greatly appreciated.

Mazda Technical Services

PE12-019

MADZA

9/6/2012

APPENDIX 11

DEALER

COMMUNICATIONS

2704L

Tribute Accelerator Cable

Recall 2704L

## Howell, Rosa (NHTSA)

---

**From:** Field Communications (eFC)  
**Sent:** Wednesday, January 19, 2005 1:37 PM  
**Subject:** Tribute Accelerator Cable Recall 2704L  
**Attachments:** eFC-I-05-00036.pdf; 05-00036a-Frequently Asked Questions.doc

**\*\*\* PLEASE DO NOT REPLY TO THIS MESSAGE \*\*\***

**Originator:** Hazel Tippings

**Subject:** Tribute Accelerator Cable Recall 2704L

**Summary:** Accelerator cable may prevent the throttle from returning to the idle position.

This notice is Information Only.

Click on the attached file(s) to open and review the eFC document(s)

PE12-019

MADZA

9/6/2012

APPENDIX 11

DEALER

COMMUNICATIONS

6812G



**TO:** All Mazda Dealership General Managers, Service Managers, and Parts Managers  
**DATE:** July 2012  
**SUBJECT:** 2001 - 2008 Tribute Engine Cover Modification Voluntary Safety Recall 6812G

Mazda Motor Corporation has decided that a defect which relates to motor vehicle safety exists in certain 2001 - 2008 Tribute vehicles equipped with 3.0L engine and cruise control.

There may be inadequate clearance between the engine cover and the speed control cable, which could allow the throttle to stick when the accelerator pedal is fully or almost-fully depressed, increasing the risk of an accident.

**Parts are currently being secured to perform the permanent repair.** We are closely working with our suppliers to accelerate parts availability. Until service parts to modify the engine cover are available, dealers are to perform the interim repair described below to eliminate the possibility of a stuck throttle when the accelerator is fully or almost-fully depressed. It is anticipated that parts for the permanent repair will be available mid-August 2012.

**Interim Repair:**

Dealers are to disconnect and secure the speed control cable away from the throttle linkage. This service must be performed on all affected vehicles at no charge to the vehicle owner. Refer to Attachment II. We will publish updated service procedures, parts information, and warranty information for the permanent repair when parts are available.

Owners of affected vehicles will be notified by first class mail beginning August 6, 2012. Dealers should repair any affected vehicles that arrive at their dealerships, whether or not the customer has received a letter.

This package contains important information about Voluntary Safety Recall 6812G:

Attachment I	Service Information
Attachment II	Interim Repair Procedure
Attachment III	Initial Owner Notification Letter
Attachment IV	Acknowledgement of Interim Service Offer

The National Traffic and Motor Vehicle Safety Act prohibits the delivery of any subject vehicle without performing the necessary repair for defects or failures. Failure to perform applicable recalls before delivery can result in extensive dealer fines and penalties from the Federal Government. Therefore, you must complete this recall for all affected vehicles in your inventory prior to delivery.



Page 2

To help you effectively perform this recall, Mazda has developed the following resources:

1. The attached service information (Attachment I) and the interim repair procedure (Attachment II) were emailed to your Service Department and are also available on eMDCS and MS3 (Mazda Service Support System) websites via MXConnect
2. For technical assistance, contact the Technical Assistance Hotline at (888) 832-8477, Option 3 for English speaking Hotline Specialist, Option 4 for Spanish speaking Hotline Specialist.
3. For warranty questions, contact the Warranty Hotline at (877) 727-6626, Option 3.

Please make certain the appropriate personnel in your dealership are aware of these resources and are familiar with the details of this recall before responding to customer inquiries.

We apologize for any inconvenience this recall may cause you and your customers. Your understanding and support in carrying out this campaign is greatly appreciated.

Sincerely,

Satoshi Takahashi  
Director, Technical Services Division  
Mazda North American Operations

**CONDITION OF CONCERN**

On 2001 - 2008 Tribute vehicles equipped with 3.0L engine and cruise control, there may be inadequate clearance between the engine cover and the speed control cable, which could allow the throttle to stick when the accelerator pedal is fully or almost-fully depressed, increasing the risk of an accident.

**Parts are currently being secured to perform the permanent repair.** Until service parts to modify the engine cover are available, dealers are to perform the interim repair described below to eliminate the possibility of a stuck throttle when the accelerator is fully or almost-fully depressed. It is anticipated that parts for the permanent repair will be available mid-August 2012. We are closely working with our suppliers to accelerate parts availability.

**Interim Repair:** Dealers are to disconnect and secure the speed control cable away from the throttle linkage. This service must be performed on all affected vehicles at no charge to the vehicle owner. Refer to Attachment II.

**IMPORTANT**

Because parts for the permanent repair are not yet available, if a customer declines to have the interim repair performed on their vehicle, complete the Acknowledgement of Interim Service Offer (Attachment IV), including the VIN, and have the customer sign it. However, please make every effort to explain to the customer the risks associated with declining the interim repair and convince the customer to have the interim repair completed. Fax the completed, signed form to MNAO Customer Assistance at 949-727-5492. Keep a copy for your dealership's records.

Owners of affected vehicles will be notified by first class mail beginning August 6, 2012. Dealers should repair any affected vehicles that arrive at their dealerships, whether or not the customer has received a letter.

**SUBJECT VEHICLES**

<b>Model</b>	<b>VIN Range</b>	<b>Build Date Range</b>
2001-2008 MY Tribute equipped with 3.0L engine and cruise control	4F2*****1K [REDACTED] through 8KM [REDACTED]	April 17, 2000 through June 20, 2008

The asterisk symbol "\*" can be any letter or number.

**OWNER NOTIFICATION**

Mazda will notify U.S. owners by first class mail beginning **August 6, 2012**.

**PARTS INFORMATION**

Parts are not required to complete the interim repair. We anticipate service parts to perform the permanent repair will be available mid-August 2012. We will publish service procedures, parts information, and warranty information for the permanent repair when parts are available.

**WARRANTY CLAIM PROCESSING INFORMATION**

	<b>* Interim Repair – Disconnect &amp; secure speed control cable away from throttle linkage</b>
Warranty Type	<b>R</b>
Symptom Code	99
Damage Code	99
Process Number	<b>J1204A</b>
Part Number Main Cause	AJC8-10-2F0
Quantity	0
Labor Operation Number	<b>YY741XRX</b>
Labor Hours	0.2 hrs

**\* THIS IS AN INTERIM REPAIR ONLY. IT WILL NOT CLOSE SAFETY RECALL 6812G.**

**VERIFY THE VEHICLE NEEDS THE RECALL**

1. Verify the vehicle is within the following ranges:

<b>Model</b>	<b>VIN Range</b>	<b>Build Date Range</b>
2001 – 2008 Tribute equipped with 3.0L engine and cruise control	4F2*****1K [REDACTED] through 8K [REDACTED]	April 17, 2000 through June 20, 2008

2. Perform a Warranty Vehicle Inquiry using your eMDCS System.

**eMDCS System - Vehicle Status Inquiry Results**

<b>If eMDCS displays:</b>	<b>Action to perform:</b>
RECALL 6812G OPEN	Proceed to “REPAIR PROCEDURE”.
RECALL 6812G is not displayed	Recall does not apply to this vehicle. Return vehicle to inventory or customer.

**REPAIR PROCEDURE**

Please refer to Attachment II.

## 2001-2008 TRIBUTE 3.0L - ENGINE COVER MODIFICATION [RECALL 6812G]

**A. OVERVIEW**

In some of the affected vehicles, there may be inadequate clearance between the engine cover and the speed control cable, which could allow the throttle to stick when the accelerator pedal is fully or almost- fully depressed, increasing the risk of an accident.

Parts are not currently available to perform the permanent repair. Until service parts to modify the engine cover are available, dealers are to perform the interim repair described below to eliminate the possibility of a stuck throttle when the accelerator is fully or almost-fully depressed. It is anticipated that parts for the permanent repair will be available mid-August 2012.

**B. VEHICLE INSPECTION PROCEDURE**

1. Verify that the vehicle is within one of the following ranges:

Model	VIN Range	Build Date Range
Certain 2001 - 2008 Tribute vehicles equipped with 3.0L engine and cruise control	VIN Range: 4F2***** 1K [REDACTED] through 8K [REDACTED] 8	From April 17, 2000 through June 20, 2008

- If the vehicle is within the above range, proceed to Step 2.
  - If the vehicle is not within one of the above ranges, return vehicle to the customer or inventory.
2. Perform a Warranty Vehicle Inquiry using your eMDCS System. Refer to eMDCS System - Warranty Vehicle Inquiry Results table below.

**eMDCS System - Warranty Vehicle Inquiry Results:**

If eMDCS displays:	Action to perform:
RECALL 6812G OPEN	Proceed to "C. INTERIM REPAIR PROCEDURE".
RECALL 6812G is not displayed	Recall does not apply to this vehicle. Return vehicle to inventory or customer.

### C. INTERIM REPAIR PROCEDURE

1. Remove the three nuts (A) and the engine cover (B).

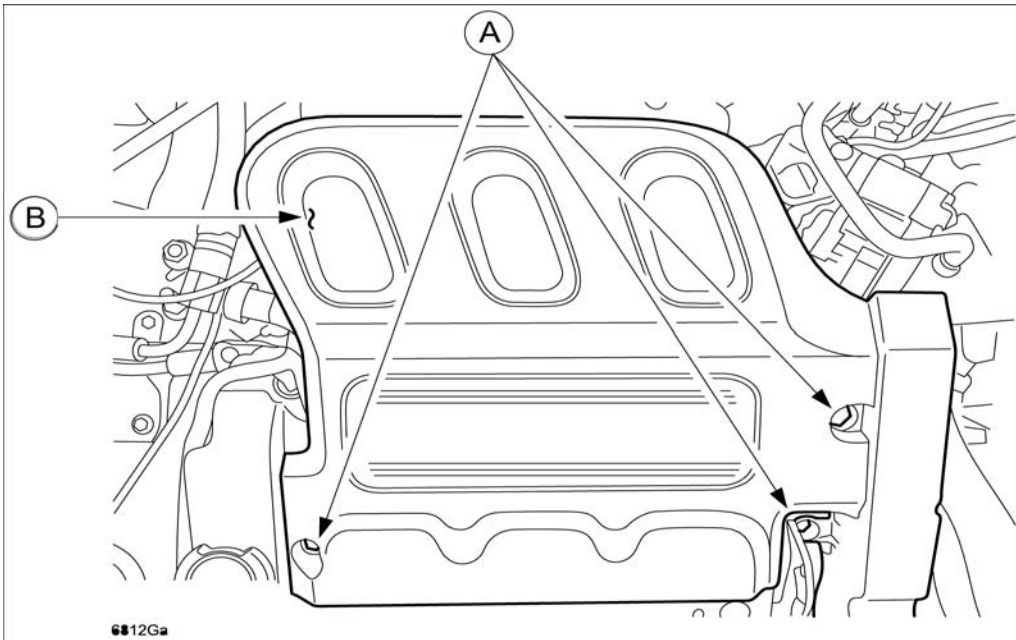

2. Slide the speed control cable off of the throttle body lever nail head (A).

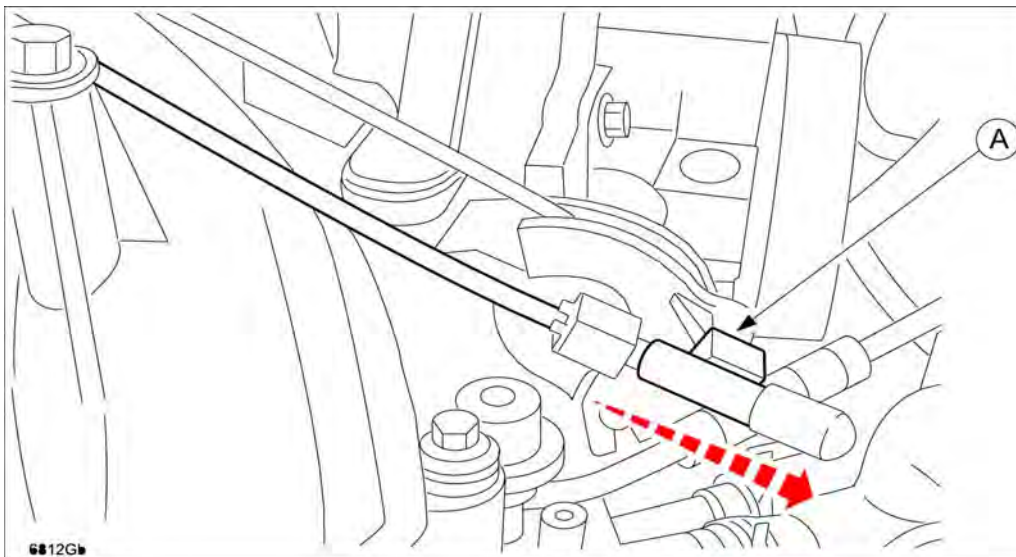

- Loosen the RH throttle cable bracket bolt (A) and remove the LH throttle cable bracket bolt (B). Rotate the bracket (C) to allow enough clearance for the speed control cable to be positioned under the bracket.

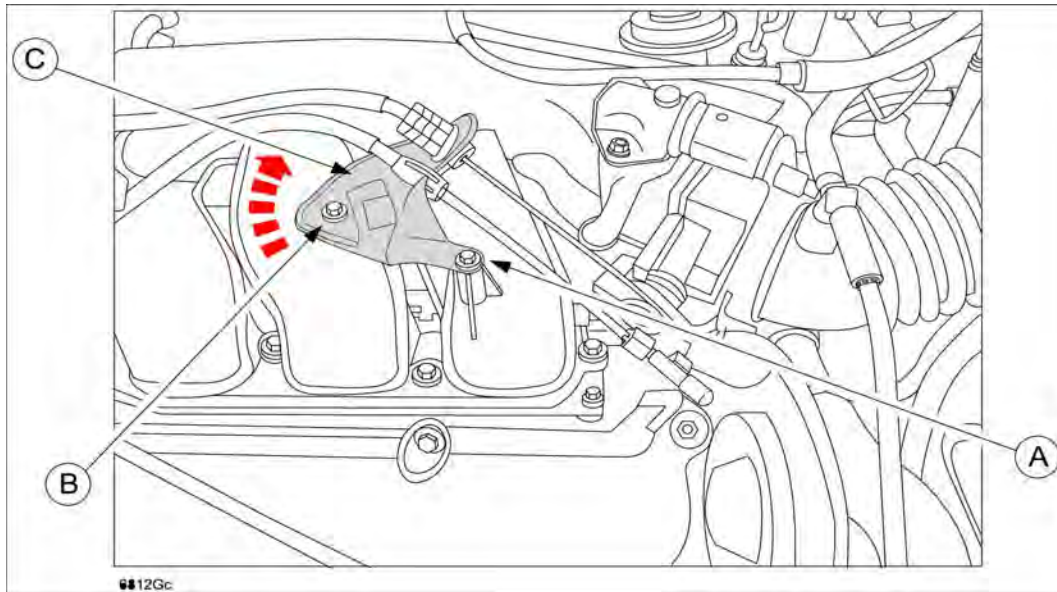

**NOTE:** Do not bend the speed control cable (A) in order to route it under the throttle cable bracket. The throttle cable bracket must be positioned aside or damage to the speed control cable may occur.

- Route the speed control cable (B) under the bracket as shown in "correct installation" below.

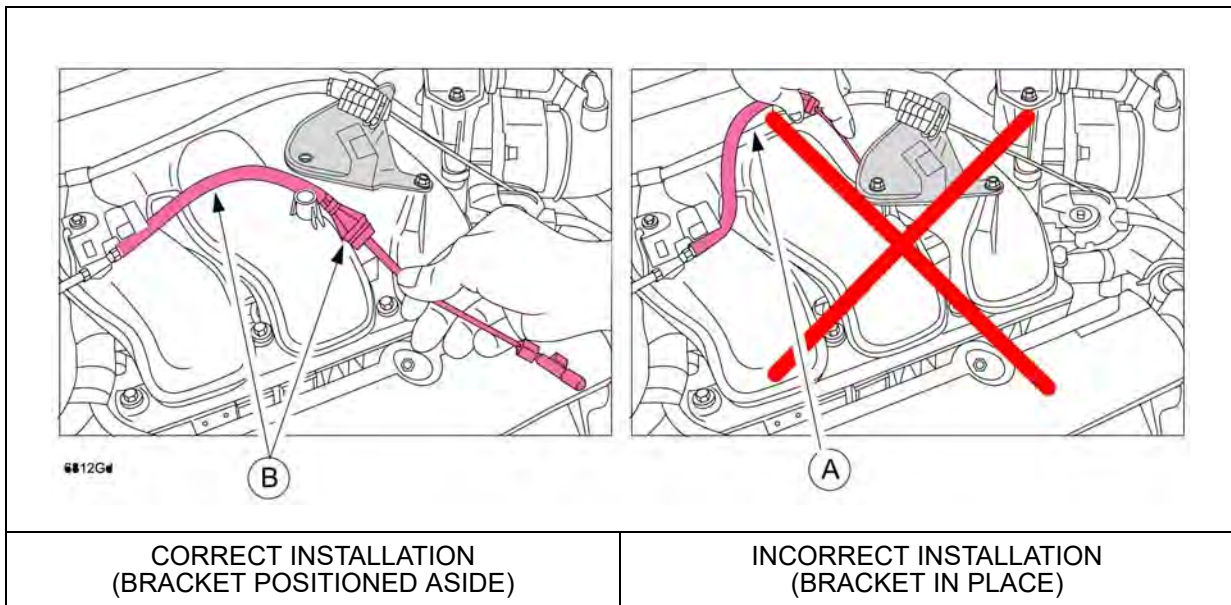

5. Reposition the throttle cable bracket (A) and tighten both bolts (B).  
Tighten the throttle cable bracket bolts (B) to 89 in-lbf (10 Nm).

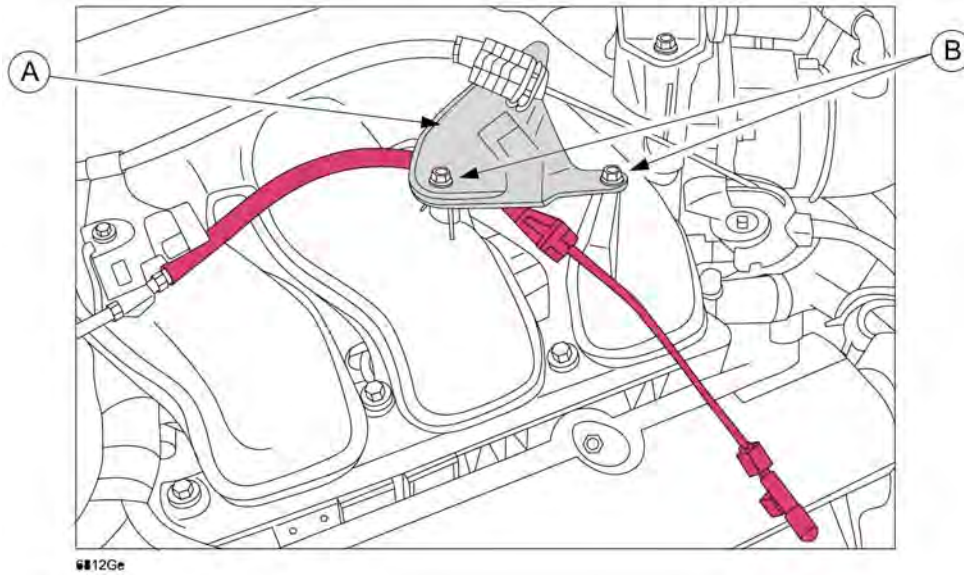

6. Reinstall the engine cover (B) and tighten the three nuts (A).  
Tighten the engine cover nuts to 53 in-lbf (6 Nm).

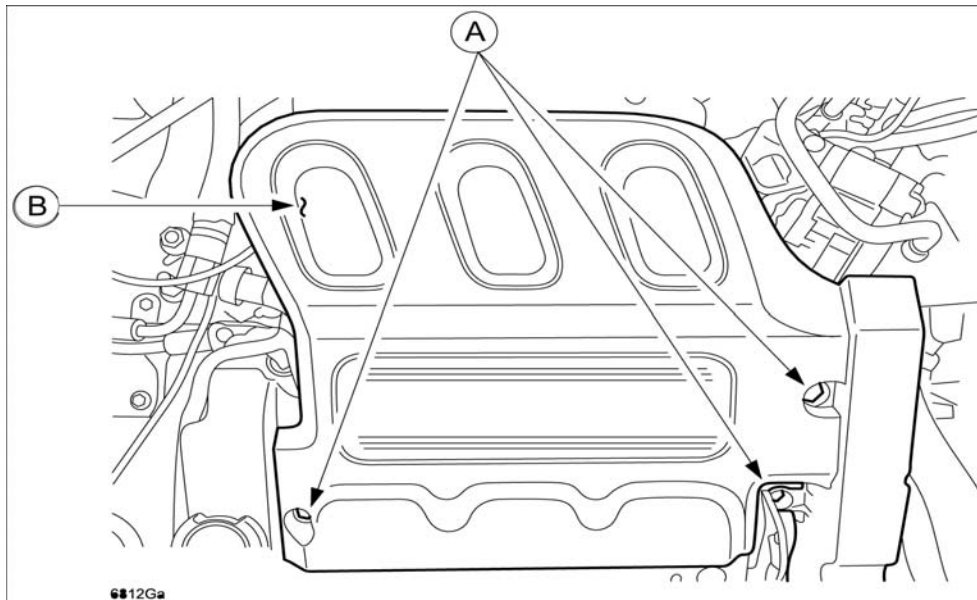

7. Return the vehicle to the customer.

August 2012

**2001 - 2008 Tribute 3.0L Engine Cover Modification Voluntary Safety Recall 6812G**

Dear Mazda Owner:

This notice is sent to you in accordance with the requirements of the National Traffic and Motor Vehicle Safety Act.

Mazda Motor Corporation has decided that a defect which relates to motor vehicle safety exists in certain 2001 - 2008 Tribute vehicles equipped with 3.0L engine and cruise control.

**If you are a recipient of this notice, your vehicle is included in this recall.**

**What is the problem?**

On your vehicle, there may be inadequate clearance between the engine cover and the speed control (sometimes known as cruise control) cable, which could allow the engine to be stuck at full power when the accelerator pedal is fully or almost-fully depressed. A throttle that is stuck fully or almost fully open may result in very high vehicle speeds and make it difficult to stop or slow the vehicle, which could cause a crash, serious injury, or death. **This risk exists regardless of whether or not cruise control is used.**

**What will Mazda do?**

Your Mazda dealer will modify the engine cover to provide sufficient clearance for the speed control cable on your vehicle free of charge. Parts for this permanent repair are expected to be available in mid-August 2012. As a result, a two-stage repair process has been implemented. If parts are available, your dealer will perform the repair. If parts are not yet available, your dealer will disconnect the speed control cable to eliminate the safety concern. With this interim repair, the speed control system will be inoperable until the permanent repair is performed.

When parts for the permanent repair are available, we will notify you again by mail to contact your dealer to have the repair performed free of charge. We recognize this may be an inconvenience, but we believe this action is in the best interest of our customer's safety. We are closely working with our suppliers to accelerate parts availability.

**How long will it take?**

The time needed for this repair is less than one-half day. However, due to service scheduling requirements, your dealer may need your vehicle for a longer period of time.

**What should you do?**

You can temporarily reduce the possibility of this condition occurring by not fully or almost-fully depressing the accelerator pedal until the vehicle is repaired. If you experience what you believe is a stuck throttle in this or any other vehicle, you should firmly and steadily apply the brakes without pumping the brake pedal, shift to neutral, steer the vehicle to a safe location and shut the engine off after the vehicle is safely stopped.

**Mazda is concerned for your safety. Please call your dealer without delay and request a service appointment for this recall. Provide the dealer with the Vehicle Identification Number (VIN) of your vehicle.**

**Where is the closest Mazda dealer?**

To locate your nearest Mazda dealer, visit our web site and try our "Locate a Dealer" feature at [www.MazdaUSA.com](http://www.MazdaUSA.com).

**Moved or no longer own this vehicle?**

If you have moved or no longer own your Mazda vehicle, please complete the enclosed prepaid *Information Change Card* as soon as possible. This enables us to update our records and notify the current owner.

**Federal law requires that any vehicle lessor receiving this recall notice must forward a copy of this notice to the lessee within ten days.**

**Still have questions?**

If you have any questions regarding this campaign, please contact our Customer Assistance Center at (800) 222-5500, option #6.

If Mazda or its dealers do not repair the defect free of charge and within a reasonable amount of time, you may notify the Administrator of the National Highway Traffic Safety Administration, 1200 New Jersey Ave., SE., Washington, DC 20590; or call the toll-free Vehicle Safety Hotline at 1-888-327-4236 (TTY: 1-800-424-9153); or go to <http://www.safercar.gov>.

We apologize for the inconvenience this situation causes, and assure you that we are doing everything possible to expedite resolution.

Sincerely,

**Mazda North American Operations**

**FOR USE ONLY UNTIL PARTS ARE AVAILABLE FOR RECALL 6812G**

**Fax completed, signed form to: 949-727-6592**

**Acknowledgement of Interim Service Offer**

Mazda has announced Safety Recall 6812G for your vehicle to address inadequate clearance between the engine cover and the speed control cable, which could result in a stuck throttle, increasing the risk of an accident. The concern exists regardless of whether or not speed control is used.

Parts for the permanent repair are currently not available. Until parts are available, Mazda is offering an interim repair at no cost to the customer to disable the speed control system to eliminate the possibility of a stuck throttle when the accelerator is fully or almost-fully depressed.

This form acknowledges that the customer:

- (1) has been fully informed by the dealer about the risks associated with declining the interim repair, including the increased risk of an accident,  
and
- (2) has chosen not to have the interim repair completed.

\_\_\_\_\_  
**Dealer Service Manager                      Date**

\_\_\_\_\_  
**Customer Signature    Date**

\_\_\_\_\_  
**Vehicle Identification Number (VIN)**

\_\_\_\_\_  
**Customer Name (Print)    Date**

PE12-019

MADZA

9/6/2012

APPENDIX 11

DEALER

COMMUNICATIONS

FAQs for 6812G

**RECALL 6812G**  
**2001-2008 Tribute 3.0L w/cruise control - Engine cover modification**

## **INTERNAL USE ONLY - NOT FOR DISTRIBUTION**

**FREQUENTLY ASKED QUESTIONS (FAQs)** - These FAQs are intended to help MNAO field managers and hotline staffs answer customer and dealer questions about safety recall 6812G.

### **CUSTOMER QUESTIONS**

**Q1. What is the issue?**

A. Mazda is voluntarily recalling 2001-2008 Model Year Tribute vehicles equipped with 3.0L engine and speed control (sometimes referred to as cruise control) to address inadequate clearance between the engine cover and the speed control cable, which could allow the throttle to stick when the accelerator pedal is fully or almost-fully depressed, increasing the risk of an accident.

**Q2. Are the vehicles safe to drive?**

A. We are advising owners that until they have a dealer perform the interim repair, they can temporarily reduce the possibility of this condition occurring by not fully depressing or almost-fully depressing the accelerator pedal. If drivers experience what they believe is a stuck throttle in this or any other vehicle, they should firmly and steadily apply the brakes without pumping the brake pedal, shift to neutral, steer the vehicle to a safe location and shut the engine off after the vehicle is safely stopped.

**Q3. Do you have an estimate of when parts for the permanent repair will be available?**

A. It is anticipated that parts for the permanent repair will be available mid-August 2012.

**Q4. Why is an interim repair required?**

A. There is a risk that the speed control cable linkage could interfere with the engine cover, which could allow the throttle to stick when the accelerator pedal is fully or almost-fully depressed, increasing the risk of an accident. The interim repair of disconnecting the speed control cable from the throttle linkage will temporarily eliminate the concern.

**Q5. If the interim repair is performed, won't the Speed Control System be disabled?**

A. Yes, customers will not be able to use speed control until the permanent repair is performed. Although some customers may regard the inability to use their Speed Control System as an inconvenience, we believe this action is in the best interest of our customers' safety.

**Q6. Approximately how many vehicles are affected?**

A. Approximately 217,000 Tributes from the 2001 through 2008 model years.

**Q7. Why are the 4 cylinder Tributes not affected?**

A. The 4 cylinder engine is completely different and has a different engine cover.

**Q.8 Why does Ford's recall cover 2001-2004 models, but your recall goes up through 2008 models?**

A. The design of the engine cover diverged between Ford and Mazda vehicles starting in 2005. Mazda used a similar design from 2001-2008.

**Q.9 Have you had any accidents or injuries reported as a result of this condition?**

A. Both the interim repair and permanent repair are designed to prevent future accidents and injuries from occurring as a result of this issue.

**RECALL 6812G**  
**2001-2008 Tribute 3.0L w/cruise control - Engine cover modification**

## **INTERNAL USE ONLY - NOT FOR DISTRIBUTION**

**Q.10 How long will it take to complete repairs, and is Mazda providing free loaner cars during that repair?**

A. The interim repair takes less than ½ day. Free loaner cars will not be provided.

### **DEALER QUESTIONS**

**Q1. What if a customer refuses to have the interim repair performed?**

A. Please make every effort to explain to the customer the risks associated with declining the interim repair and convince the customer to have the interim repair completed. If they still refuse, use the "Acknowledgement of Interim Service Offer" form posted with this bulletin to document the customer's refusal of the interim repair. Fax the completed form to Mazda Customer Assistance at 949-727-6592 and retain the signed letter in the customer's file for future reference.

PE12-019

MADZA

9/6/2012

APPENDIX 11

DEALER

COMMUNICATIONS

6812G

Safety Recall 6812G Launch -  
2001-2008 Tribute Engine  
Cover Modification

## Howell, Rosa (NHTSA)

---

**From:** Technical Services Division  
**Sent:** Friday, July 27, 2012 5:19 PM  
**Subject:** Safety Recall 6812G Launch - 2001-2008 Tribute Engine Cover Modification  
**Importance:** High



*Mazda DEALER EMAIL*

*zoom-zoom*

*zoom-zoom*

### Attention Mazda Service and Parts Managers:

Mazda Motor Corporation has decided that a defect which relates to motor vehicle safety exists in certain 2001 - 2008 Tribute vehicles equipped with 3.0L engine and cruise control.

There may be inadequate clearance between the engine cover and the speed control cable, which could allow the throttle to stick when the accelerator pedal is fully or almost-fully depressed, increasing the risk of an accident.

Parts are currently being secured to perform the permanent repair. We are closely working with our suppliers to accelerate parts availability. Until service parts to modify the engine cover are available, dealers are to perform an interim repair, to disconnect and secure the speed control cable away from the throttle linkage to eliminate the possibility of a stuck throttle when the accelerator is fully or almost-fully depressed. It is anticipated that parts for the permanent repair will be available mid-August 2012.

We will publish updated service procedures, parts information, and warranty information for the permanent repair when parts are available.

Owners of affected vehicles will be notified by first class mail beginning August 6, 2012.

### SUBJECT VEHICLES

Model	Affected VINs	Build Dates
2001-2008 MY Tribute equipped with 3.0L engine and cruise control	4F2****1K [REDACTED] through 8K [REDACTED]	April 17, 2000 through June 20, 2008

The asterisk symbol "\*" can be any letter or number.

Recall 6812G service information and repair procedure are available on the Mazda Service Support System (MS3) website and on eMDCS.

For technical assistance, contact the Technical Assistance Hotline at (888) 832-8477, Option 3 for English speaking Hotline Specialist, option 4 for Spanish speaking Hotline Specialist.

For warranty questions, contact the Warranty Hotline at (877) 727-6626 Option 3.

Please make certain that the appropriate personnel in your dealership are aware of these resources and are familiar with the details of this recall before responding to customer inquiries. If you have any questions, please contact your DSM.

We apologize for any inconvenience this recall may cause you and your customers. Your understanding and support in carrying out this campaign are greatly appreciated.

### **Mazda Technical Services**

PE12-019

MADZA

9/6/2012

APPENDIX 11

DEALER

COMMUNICATIONS

93008



Recall Start August 2000

**2001 Tribute  
Cruise Control Cable Cap Damage  
[Recall #93008]**

**TO:** All **Mazda** Dealers

**ATTENTION:** All General Managers, Service Managers, and Parts Managers

**SUBJECT:** **Recall Campaign 93008**  
2001 Tribute – Cruise Control Cable Cap Damage

Dear **Mazda** Dealer:

**Mazda Motor Corporation** has determined that a defect, which relates to motor vehicle safety, exists on some 2001 Tribute vehicles produced from April 17, 2000 through July 24, 2000.

On some of the affected vehicles, a damaged cruise control cable cap tab could potentially enter the actuator clutch cavity and interfere with the speed control. Additionally, it is possible for water to enter those units with a cracked or missing speed control cap-locating tab. Water entry into the actuator could eventually cause corrosion that could potentially interfere with the speed control function. Either of these conditions may possibly result in a stuck throttle and non-return to idle when disengaging the speed control, which could result in an accident.

**Mazda** has decided to conduct a recall campaign to replace cruise control cable assemblies with cracked or missing speed control to actuator cap locating tabs. This campaign is scheduled to begin on August 25, 2000.

Detailed information regarding this recall is provided in Attachment I and the repair procedures are located in Attachment II.

**The National Traffic and Motor Vehicle Safety Act prohibits selling or leasing any subject vehicles without performing the necessary repair for defects or failures. Failure to perform applicable recalls before sale can result in extensive fines and penalties from the Federal Government. Therefore, you must complete this recall for all affected new and used vehicles in your inventory prior to sale or lease.**

Please make certain that the appropriate personnel in your dealership are familiar with the details of this recall for responding to customer inquiries. Should you have any questions, please contact the **Warranty Hotline at (800)-622-6779**.

We apologize for any inconvenience that this program may cause you and your personnel. Your understanding and support in carrying out this campaign is greatly appreciated.

Sincerely,

**Mazda North American Operations**

**CONDITION OF CONCERN**

Some cruise cable to actuator cap assemblies were damaged during the molding process. This damage can lead to cracked or broken cable to actuator cap mounting tabs. If broken, the tabs could enter into the actuator clutch cavity and interfere with the speed control function. Additionally, it is possible for water to enter through a cable to actuator cap with cracked or broken mounting tabs. This water could eventually cause corrosion that may interfere with the speed control function. The affected cruise cable to actuator caps were molded from cavity number 3 and number 4. Either of the above conditions may possibly result in a stuck throttle and non-return to idle when disengaging the speed control, which could result in an accident.

**SUBJECT VEHICLES**

Model Year & Model	VIN Range	Build Date Range
2001 Tribute	4F2*****1 [REDACTED] to 4F2*****1 K [REDACTED]	04-17-00 to 07-24-00

Note: 1) The asterisk symbol "\*" can be any number or letter

**OWNER NOTIFICATION**

All owners of the affected vehicles have been notified by phone or mail. **Mazda** dealers will inspect and replace the cruise control cable assembly and actuator.

**REQUIRED PARTS**

Part Description	Part Number	Quantity
Cruise Control Cable	EC05-66-311D	1
Cruise Control Actuator	EC05-66-312D	1
Authorized Modification Label	9999-95-065A-00	1

Replacement parts will be drop shipped to dealers. The quantity shipped to each dealer will be based on the number of vehicles allocated to that dealer.

Please verify that you have the necessary parts before making an appointment to perform the recall campaign on a customer's vehicle.

Authorized Modification Labels are supplied at no charge and available in 8 ½" x 11" sheets containing 18 labels. Please use MStore to order labels.

**REPAIR PROCEDURES**

Please refer to Attachment II.

**WARRANTY CLAIM PROCESSING INFORMATION**

	Inspection Only	Inspection and Repair
Warranty Code Type	R	R
Symptom Code	99	99
Damage Code	99	99
Process Number	J0005A	J0005B
Part Number Main Cause	EC05-66-311D	EC05-66-311D
Quantity	0	1
Labor Operation	YY215XRX	YY216XRX
Labor Hours	0.3	0.5

**2001 TRIBUTE [RECALL 93008] CRUISE CONTROL CABLE CAP DAMAGE**

**A. VEHICLE INSPECTION PROCEDURE**

1. Verify VIN and build date are within the following ranges:
  - VIN: 4F2\*\*\*\*\*1 [REDACTED] -4F2\*\*\*\*\*1 K [REDACTED]
  - Build Date: April 17, 2000 - July 24, 2000
  - If vehicle is within the above range, proceed to STEP 2.
  - If vehicle is not within the above ranges, return it to the customer or inventory.
2. Perform a [Warranty Vehicle Inquiry](#) using your [MDCS System](#) and inspect vehicle for an Authorized Modification Label **RECALL #93008** attached to the drivers side door. Refer to illustration below.

**Note**

- Be sure to verify the recall number as the vehicle may have multiple labels.

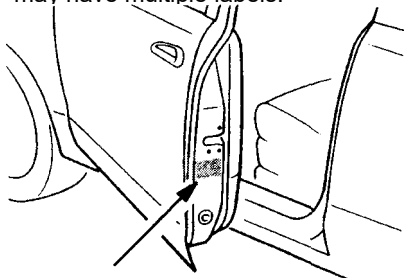

**AUTHORIZED MODIFICATION LABEL**

- If [MDCS](#) displays **RECALL: 93008 Open** and an Authorized Modification Label is **not present**, the recall has not been performed. Proceed to "[B. CRUISE CONTROL INSPECTION PROCEDURE](#)."
- If [MDCS](#) displays **RECALL: 93008 Open** and an Authorized Modification Label is **present**, contact the **Warranty Department at (800) 662-6779**. They will update the vehicle history.
- If [MDCS](#) displays **RECALL: 93008 Closed** and an Authorized Modification Label is **not present**, proceed to "[D. AUTHORIZED MODIFICATION LABEL INSTALLATION](#)."
- If [MDCS](#) displays **RECALL: 93008 Closed** and an Authorization Modification Label is **present**, the recall has already been completed. Return the vehicle to the customer or inventory.
- If [MDCS](#) does not display **RECALL: 93008 Open** or **RECALL: 93008 Closed**, this recall does not apply to the vehicle. Return vehicle to the customer or inventory.

**B. CRUISE CONTROL INSPECTION PROCEDURE**

1. Check for yellow dot on the cruise control actuator.
  - If present, the campaign has been performed and no repair work is necessary. Proceed to "[D. AUTHORIZED MODIFICATION LABEL INSTALLATION](#)."
  - If not present, proceed to STEP 2.

**CRUISE CONTROL ACTUATOR**

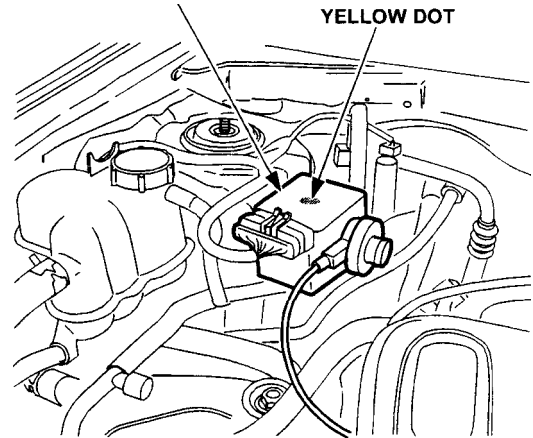

2. Record radio presets, open hood, and disconnect the battery ground cable.
3. Remove the cruise control cable cap from the actuator by pushing in the cable lock tab and rotating assembly counter-clockwise.

**PUSH IN CABLE LOCK TAB AND ROTATE CAP COUNTER-CLOCKWISE**

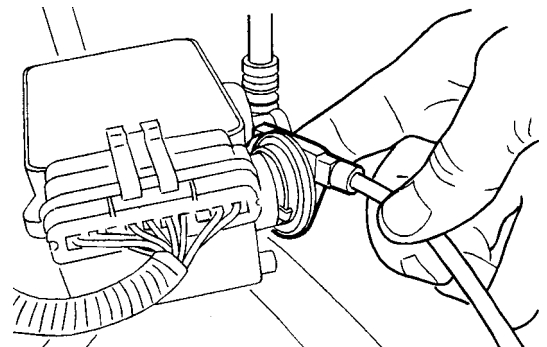

4. Separate the cruise control cap from the actuator and inspect number at the cable to cap connection as shown in the following illustration.

**Note**

- Do not remove the cable from the servo cam.

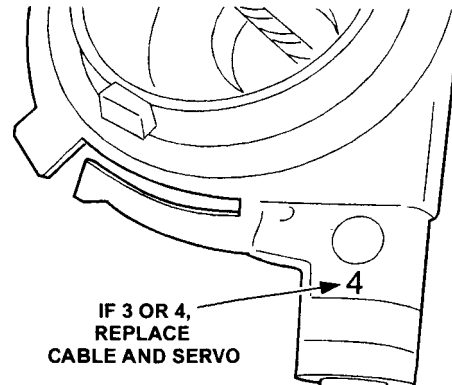

## **2001 TRIBUTE [RECALL 93008] CRUISE CONTROL CABLE CAP DAMAGE**

- If the cavity is #3 or #4, proceed to "C. Repair Procedure."
- If not, reassemble cruise control cable cap and place a yellow paint mark on top of the servo to indicate completion of repair. Reconnect the battery ground cable and set radio presets. Proceed to "**D. AUTHORIZED MODIFICATION LABEL INSTALLATION.**"

### **C. REPAIR PROCEDURE**

1. Remove the cruise control cable from the actuator.
2. Remove the three (3) engine cover retaining nuts and remove cover.
3. Remove cruise control actuator assembly by disconnecting the electrical connector and removing the three (3) actuator bracket nuts.
4. Remove the cruise control cable from the engine bracket and throttle linkage.
5. Replace the actuator and cable with countermeasure parts.
6. Install in reverse order of removal.
7. Reconnect battery ground cable and set radio presets.
8. Place a yellow paint mark on top of the servo to indicate completion of repair.
9. Verify repair.

### **D. AUTHORIZED MODIFICATION LABEL INSTALLATION**

Complete an "Authorized Modification Label" with the recall number written on the sticker and affix it to driver's side door under the door latch. Refer back to the illustration under "**A. VEHICLE INSPECTION PROCEDURE**" on page one (1).

PE12-019

MADZA

9/6/2012

APPENDIX 11

DEALER

COMMUNICATIONS

TSB 01-014-02

<b>Subject:</b>  INTERMITTENT ENGINE QUIT OR IDLE DIP	<b>Bulletin No:</b> 01-014/02R
	<b>Last Issued:</b> 12/16/2002

## NOTE

- This bulletin supersedes Last Issued: 10/01/2002.

## APPLICABLE MODEL(S)/VINS

2001-2003 Tributes with 3.0L Duratec engine only built prior to 9/16/02.

## DESCRIPTION

Some vehicles equipped with a 3.0L Duratec engine may exhibit an intermittent engine quit condition. This is usually a one time event during closed throttle deceleration with no Diagnostic Trouble Codes (DTCs) and no Malfunction Indicator Lamp (MIL). The engine will restart immediately. Because of an intermittent nature, the condition may not be possible to duplicate.

When normal diagnostics cannot pinpoint the root cause, refer to the following Driveability Checklist for details.

## REPAIR PROCEDURE

**NOTE:** This concern may have several causes so it is important to thoroughly complete each step.

**NOTE:** Make sure the vehicle is in the following conditions when performing all tests described below:

- Transmission in Park
- Engine at idle at approximately 750 RPM
- Engine temperature should be at least 88°C (190°F)
- All accessories and the engine cooling fan should be off

**NOTE:** Parts will be collected for warranty inspection and any unnecessary replacements will be debited.

### 1. Inspection of Evaporative (EVAP) Vapor Management Valve

- Determine if the Evaporative Vapor Management (EVAPVM) duty cycle is operating properly. Monitor these parameters using PIDs - EVAPVM # (in percent) and FTP (in volts).
  - If EVAPVM is functioning correctly, the duty cycle should increase to 84-100% with the FTP decreasing to approximately 2.2 volts and then reset back to 0% duty cycle while FTP hold at approximately 2.6 volts. If the duty cycle does not increase within 5 minutes, turn on the headlights and the AC with the blower on high. The duty cycle should start increasing within 5-10 minutes. Do not replace the EVAPVM valve if the duty cycle functions correctly.
  - If the duty cycle stops increasing and remains at 95-100% while Fuel Tank Pressure (FTP) holds at

**CONSUMER NOTICE:** The information and instructions in this bulletin are intended for use by skilled technicians. Mazda technicians utilize the proper tools/equipment and take training to correctly and safely maintain Mazda vehicles. These instructions should not be performed by "do-it-yourselfers." Customers should not assume this bulletin applies to their vehicle or that their vehicle will develop the described concern. To determine if the information applies, customers should contact their nearest authorized Mazda dealership.

approximately 2.6 volts, replace the EVAPVM valve with part number AJ03-18-741A.

**EVAP VAPOR MANAGEMENT VALVE**

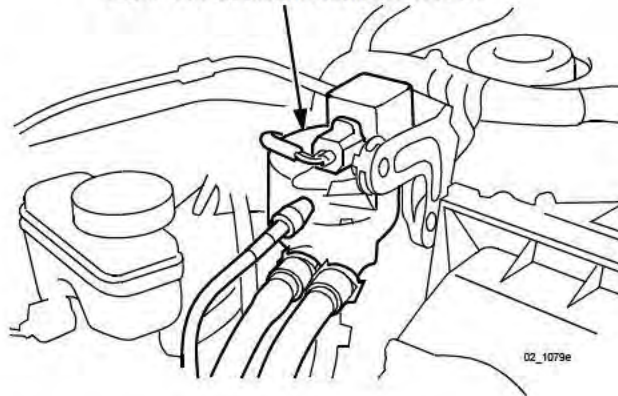

b. Verify corrective action, then proceed to Step 2.

**2. Inspection of EVAP System Vent Line**

a. Disconnect the vent line in the evaporative emissions system from the check valve side. This connection is located just forward of the evaporative emissions canister assembly, underneath the vehicle in the area of the driver side rear seat.

**CANISTER ASSEMBLY WITH BRACKET REMOVED**  
**(VIEW FROM UNDERNEATH VEHICLE)**

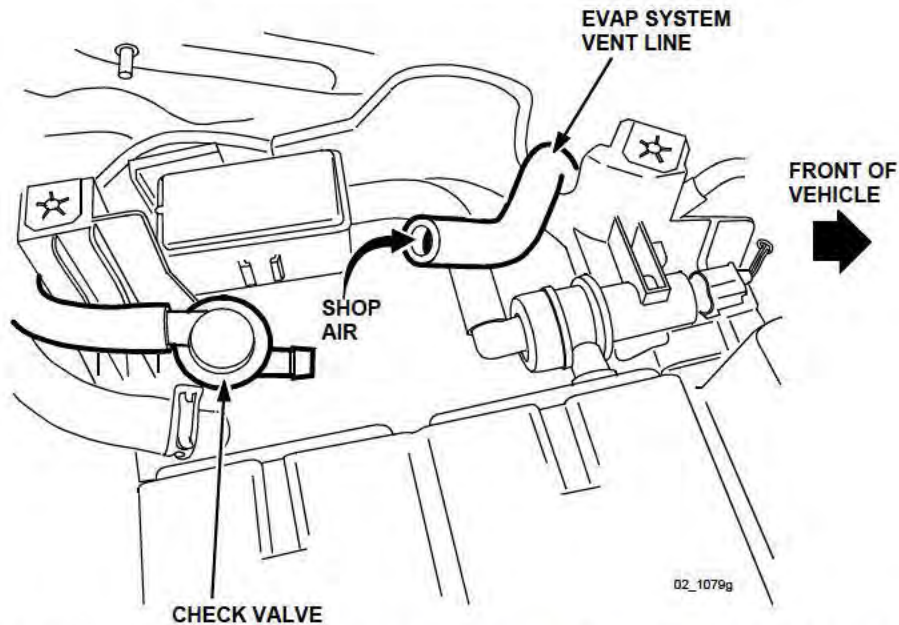

- b. Using shop air, blow the vent line from the check valve side forward (towards the brake booster). In the past, spiders have been known to construct webs in vent lines, so handle with caution. Possible obstructions in the vent line can prevent the evaporative emissions system from purging properly, and in some cases, can cause the condition to occur.
- c. Verify corrective action, then proceed to Step 3.

### 3. Inspection of Idle Air Control (IAC) Valve

- a. Inspect the Idle Air Control (IAC) valve.
  - If the valve is not stamped with part number 1L8E-9F715-AA, replace with AJ71-20-660.

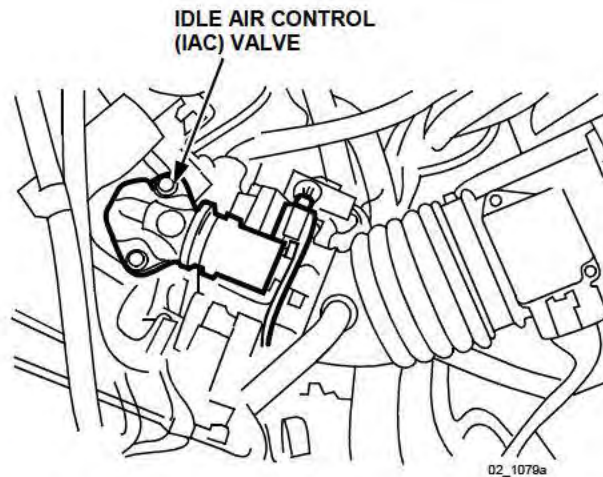

- b. Verify that IAC duty cycle is between 32-40% with no purge flow (EVAPVM duty cycle is 0%) and fuel trims (SHRTFT1, SHRTFT2, LONGFT1, LONGFT2) are less than 15%.
    - If IAC duty cycle is out of specification, replace the throttle body with part number AJ03-13-640B.
    - If IAC duty cycle is within specification proceed to Step 3c now.
  - c. If the fuel trims are above 15%, disconnect the Mass Air Flow Sensor (MAF) and recheck the fuel trims.
    - If the fuel trims drop to below 15%, replace the MAF sensor with part number 1F22-13-210A.
    - If fuel trims stay above 15%, check for vacuum leaks and check the fuel system (Refer to Workshop Manual section 01-01 and 01-14 Troubleshooting and Fuel System).
  - d. Verify corrective action, then proceed to Step 4.
- ### 4. PCM Reflashing
- a. Reprogram PCM with WDS version 21.5 or later. Only use WDS version 21.5 or later during this reprogramming.
  - b. Some 2001 model year PCMs cannot be reprogrammed and must be replaced. This is determined by the MPC # located in the upper left corner of the barcode on the PCM.
    - If the PCM is an MPC 160, then replace with part AJY8-18-881D.
    - If the PCM is an MPC 161, then just reprogram with WDS version 21.5 or later.
  - c. Verify the latest calibration was successfully reprogrammed.
    - WDS should show latest calibration level as 1U7A-12A650-AYD if PCM tear tag is # SJC0, SJC1, or SJC2.
    - For PCM tear tag # HQP1, HQP2, HQP3, or RKG0, the latest calibration level is 2U7A-12A650-CRB.
    - For tear tag # BAR0 or BAR1, the latest calibration level is 3L8A-12A650-BC.

**NOTE:** For additional details on PCM reflashing, refer to the attached **PCM REFLASH PROCEDURE SUPPLEMENT**. Then proceed to Step 5.

## 5. Inspection of Electronic Engine Control (EEC) Relay

### a. Inspection of Electronic Engine Control (EEC) Relay.

- If the Electronic Engine Control (EEC) relay has black stamped lettering, proceed to Step 6 now.
- If the EEC relay has white lettering printed on the top surface, replace with a new Hella service relay, BTDA-67-740, that is all black and has stamped lettering on the top surface.

**NOTE:** Both the new Hella service relay and the old relay have the same part number (BTDA-67-740). Make sure the relay you are installing has stamped lettering.

### b. Confirm EEC relay female terminal tightness on the Battery Junction Box side using tester part number 49-L088-OA2-020 from the Mazda terminal repair kit.

- If loose, adjust terminals as needed.
- If okay, proceed to Step 6.

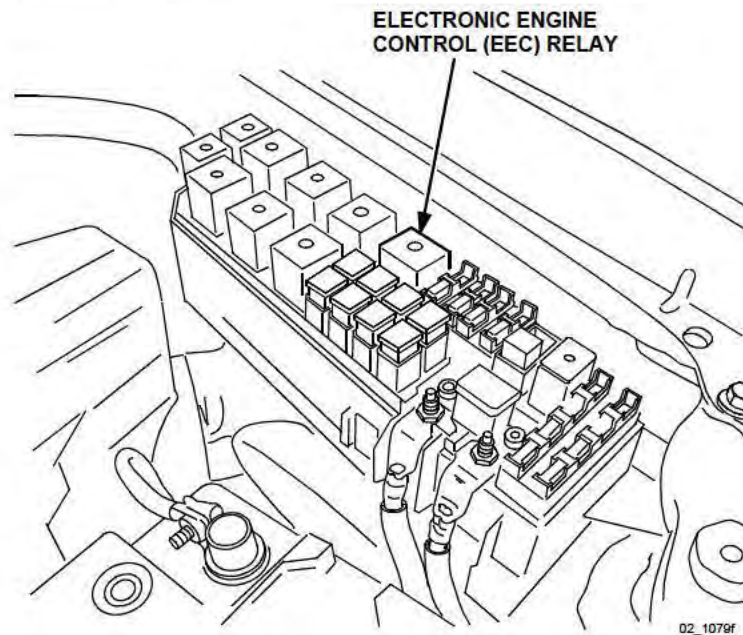

**6. Inspection of Differential Pressure Feedback EGR (DPFE) Sensor Part Number**

- If DPFE sensor is stamped with part number 2F1E-9J460-AA or AB, proceed to Step 7 now.
- If the DPFE sensor is stamped with part number YF1E-9J460-AD, check for a white dot on the sensor housing (note: white dot can be anywhere on housing). If there is a white dot, proceed to Step 7 now. If there is not a white dot, replace the DPFE with part 1F22-20-302A. Proceed to Step 7.

DIFFERENTIAL PRESSURE  
FEEDBACK, EXHAUST GAS  
RECIRCULATION (DPFEGR)  
SENSOR

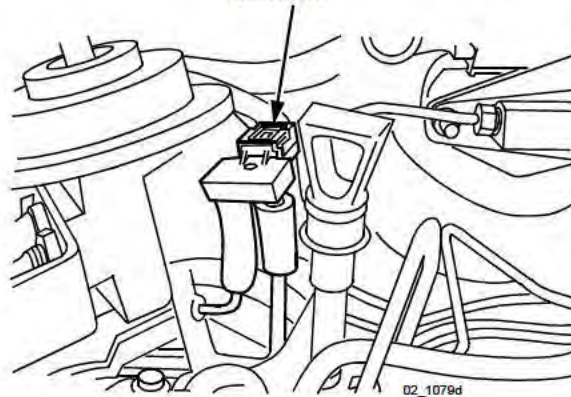
**7. Inspection of Mass Air Flow (MAF) Sensor Gasket**

- a. Ensure the Mass Air Flow (MAF) sensor gasket is properly installed and not blocking the air stream by disconnecting the airbox and looking inside the airbox towards the MAF sensor. If gasket is damaged, replace with part AJ03-13-211. Proceed to Step 8.

MASS AIR FLOW  
(MAF) SENSOR  
GASKET

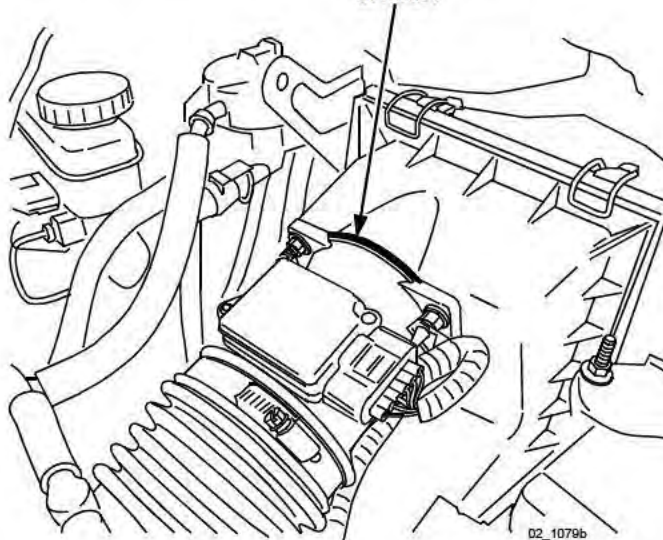

**8. Verify PCM Harness Integrity**

- a. Verify the PCM harness integrity by removing the module from the COWL and moving the PCM harness around while the engine is running. If any abnormalities are observed, repair/replace the harness. Proceed to Step 9.

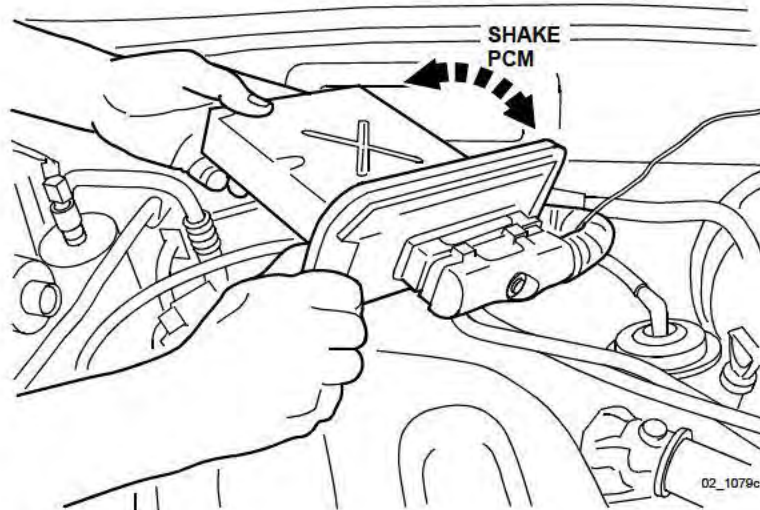
**9. Inspection of Key Ring Weight**

- a. Inform the customer that significant weight (approximately 9 oz or more) hanging from the key ring while the keys are in the ignition may move the ignition cylinder out of the Run position and stop the engine. When this occurs, all gauges immediately shut off (fuel reads "E", tachometer goes to zero, speedometer goes to zero immediately).
- b. It is recommended that the customer attaches fewer keys to the key ring that retains the vehicle ignition key.
- c. Proceed to Step 10.

**10. Road Test**

- a. Road test the vehicle long enough to experience 3 closed throttle decelerations from approximately 40 mph down to 10 mph. Use scan tool to examine engine RPM during test.
- b. Ensure that there are no engine RPM dips below 680 RPM. Then proceed to Step 11.

11. Obtain an Authorized Modification PCM Label through MStore (part number 9999-95-AMDC-97) and list the date, dealer number, and summary of modifications performed. Select a prominent place adjacent to the Vehicle Emission Control Information Decal suitable for installing the Authorized Modifications Label. Clean the area, install the decal, and cover it with a clear plastic decal shield.

<b>Bulletin No:</b> 01-014/02R	<b>Last Issued:</b> 12/16/2002
--------------------------------	--------------------------------

**PART(S) INFORMATION**

Part Number	Description	Qty.	Notes
AJ71-20-660	Bypass Valve	1	
AJ03-13-640B	Throttle Body	1	
AJ03-18-741A	Valve, solenoid	1	
BTDA-67-740	Relay, coolant fan	1	Electronic Engine Control (EEC) Relay
AJY8-18-881D	Control unit, EGI	1	Powertrain Control Module (PCM) Replaces JYB2, JYB3 tear tag PCMs
1F22-13-210A	Reman Sensor Air Flow	1	
1F22-20-302A	Sensor, ENG	1	
AJ03-13-211	Gasket	1	

**WARRANTY INFORMATION**

**NOTE:** This information applies to verified customer complaints on vehicles covered under normal warranty. Refer to the SRT microfiche for warranty term information.

**NOTE:** Parts will be collected for warranty inspection and any unnecessary replacements will be debited.

Warranty Type	A
Symptom Code	05
Damage Code	9W
Part Number Main Cause	AJY8-18-881D
Quantity	0 or 1
Operation Number / Labor Hours	YY289XRX / 1.2 (includes reflashing of the PCM and vehicle repair) YY290XRX / 1.5 (includes replacement and reflashing of the PCM and vehicle repair)

## PCM REFLASH PROCEDURE SUPPLEMENT

(All 2001 Model and early 2002 Model with PCM tear tag of "SJC0, SJC1, or SJC2", 2002 Model with PCM tear tag of HQP1, HQP2, HQP3, or RKG0, and 2003 Model with PCM tear tag BAR0 or BAR1)

### NOTE:

- WDS shows the calibration part number after programming the PCM.
- Please be aware that PCM calibration part numbers and file names listed in any Service Bulletin may change due to future releases of WDS software and additional revisions made to those calibrations for service related concerns. When reprogramming a PCM, WDS will always display the "latest" calibration P/N available for that vehicle. If any calibration has been revised/updated to contain new information for a new service concern/issue, it will also contain all previously released calibrations.

**Connect WDS to the vehicle and perform the below PCM calibration re-flash procedure. Please pay special attention to the following Vehicle PCM information BEFORE beginning this procedure:**

- If vehicle PCM tear tag # is JYB2, JYB3 (MPC-160 level) you must first replace PCM with a later style PCM with Tear Tag # of SJC0, SJC1, SJC2, or SJA3 (MPC-161 level) by performing the PROGRAMMABLE MODULE INSTALLATION (PMI) PROCEDURE (See Procedure 1).
- If vehicle PCM tear tag # is SJC0, SJC1, SJC2, HQP1, HQP2, HQP3, RKB0, BAR0, or BAR1 use WDS B21.5 or later and re-flash PCM by performing the "module reprogramming" procedure. (See Procedure 2)

The latest calibration PCM P/N for tear tag SJC0, SJC1, or SJC2 is 1U7A-12A650-AYD. File name is DOAR63W.

If vehicle PCM tear tag is HQP1, HQP2, HQP3, or RKG0, the latest calibration PCM P/N is 2U7A-12A650-CRB. File name is DOAR63Y.

If vehicle PCM tear tag is BAR0 or BAR1, the latest calibration PCM P/N is 3L8A-12A650-BC. File name is DOAV535.

### Procedure 1

(For 3.0L vehicles with PCMs that have tear tag numbers of JYB2 or JYB3. For all other PCM tear tag numbers, refer to Procedure 2.)

**Note:** When replacing a powertrain control module (PCM), the following items are required:

- WDS with B21.5 or later software loaded.
- Minimum two ignition keys for reprogramming PATS (be sure to ask customer for ALL spare keys).
- Obtain new PCM part number AJY8-18-881D.
- With old PCM still in vehicle follow procedure below.

**Note:** When performing this procedure, if the WDS PTU is not docked and connected to 115V-120V, we recommend that a battery charger be installed on the vehicle battery and turned ON to a maximum charge of no more than 20 AMPS to keep the vehicle battery up to capacity. If you exceed 20 AMPS it will damage the WDS PTU.

1. Connect WDS DLC cable to vehicle's DLC connector (lower portion of dash in front of driver).
2. Press "16 PIN", "All except those below", and then press tick.
3. Screen shows cable hookup. Turn ignition switch to ON. Press Tick.
4. Screen shows WDS communicating with PCM "progress bar" and "Operation in progress".
5. Wait until WDS finishes collection of PCM information. (hard drive light quits flashing). Then the "Vehicle Specification" screen appears with VIN # information. It asks you "Is this correct? Press "Yes" if information is correct.

6. Screen appears to fill out R.O. information and mileage. Fill out information and then press tick. Or skip this by pressing tick.
7. With screen showing "Vehicle Specification", press "Tool Box".
8. Another menu appears. Select "Module programming" then press tick. "Please Wait" appears.
9. Then another menu appears. Select "Programmable module installation" then select "PCM" then press Tick.
10. Screen shows "Set ignition switch to OFF (position 0)". Do this and press tick.
11. Screen shows "Install a new module in vehicle". Replace the PCM with the new unit, then press tick.
12. Screen shows "Remove the fuses for fuel pump and additional fans as this may cause interference and battery drain during the programming process". Do this and press tick.  
**Note:** There are two 50 amp fuses (on 3.0L) labeled "Main Fan" and "Add Fan". Remove only the 50 Amp fuses to deactivate the fans. Fuel pump is a mini fuse 20 amp (position 6) at front end of fuse box.
13. Screen shows "Set ignition switch to the ON position". Do this and press tick
14. Screen shows "Downloading data" box with "progress bar". Please wait 2-3 minutes.
15. Screen now shows "Set ignition switch to the OFF position". Do this and press tick.
16. Screen now shows "Set ignition switch to the ON position". Do this and press tick.
17. Screen shows "Set the ignition switch to OFF (position 0)". Do this and press tick.
18. Screen shows "Calibration has been loaded and checked". Press tick.
19. Screen shows "Re-install fuses for fuel pump and additional fans". Do this, then press tick.
20. Screen shows "Obtain a PCM label and fill in the PCM data shown with the date on the WDS screen. Install in the appropriate position. (New label should be in the new PCM part box) **DO NOT FILL OUT PCM LABEL AT THIS TIME!** Press tick.
21. Screen shows "start engine. Do not depress throttle". **THIS IS INCORRECT!!!!** You must follow the below procedure to start the vehicle:
  - Turn ignition OFF, Turn KEY ON (Count 3 secs. security light is ON solid) Turn key OFF, remove key.
  - Insert 2nd key, turn key ON, (security light stays ON for 3 secs. goes out) then start engine. Turn OFF engine, remove key.
  - both keys programmed.
22. Now with Key OFF, press "Select Systems Options" or "Menu" ICON (at the upper right hand side of screen). Press "EXIT" and push the green tick. This will return you to the "Vehicle Specifications" screen.
23. Now press the "Close session" ICON (lower left hand side of screen, 3rd ICON) and press "delete (deletes session)". Press tick.
24. Now, Press "16 PIN", "All except those below", and then tick.
25. Screen shows cable hookup. Turn ignition switch to ON. Press tick.
26. Screen shows WDS communicating with PCM "progress bar" and "Operation in progress".
27. Wait until WDS finishes collection of PCM information (hard drive light quits flashing). Then the "Vehicle Specification" screen appears with VIN # information. It asks you "Is this correct?" **Press NO.**
28. Then the "Vehicle Specification" screen appears again and asks: "Is this correct?" **Press NO** again.

29. Screen shows "Incorrect Calibration Programmed." Press tick.
30. Screen shows "To enable WDS to identify PCM, please enter one of the following information:
  - PCM part number or
  - Calibration number (7, 10, or 15 digits) or
  - Tear tag numberPress tick.
31. Press the light blue box area next to "tear tag" and enter "SJC0, SJC1, SJC2, or SJA3" (whatever the tear tag number of the new PCM is) and press tick.
32. Vehicle specification screen appears asking "Is this correct?" **Now press YES.**
33. Screen shows "Turn Ignition switch OFF". Do this and press tick.
34. Screen shows "Remove the fuses for fuel pump and additional fans as this may cause interference and battery drain during the programming process". Do this and press tick.
35. Screen shows "Turn ignition switch ON". Do this.
36. Screen shows "Downloading Data" box with progress bar. It takes approx. 2-3 minutes.
37. Screen shows "Turn ignition switch OFF". Do this. Press tick.
38. Screen shows "Turn ignition switch ON". Do this. Press tick.
39. Screen changes to "progress bar" and then changes to "Vehicle Specifications" with VIN # and asks "Is this correct?" Press Yes.
40. Screen to fill out R.O. information appears. Press tick.
41. "Vehicle Specifications" screen appears. Now Re-install fan and fuel pump fuses.
42. Now select "Tool Box", then "Module Programming", then press tick. "Please wait" appears.
43. Now select "Module Reprogramming" and "PCM". Then press tick.
44. Screen should say "No later calibration is available on the system for this PCM. The latest level for this vehicle: **1U7A-12A650-AYD**. Obtain a PCM label and fill in the PCM data shown with the date on the WDS screen. Install it next to the vehicle emissions label on the hood.
45. Now press tick.
46. Now turn Key OFF, press "Select Systems Options" or "Menu" ICON (at the upper right hand side of screen). Press "EXIT" and push the green tick. This will return you to the vehicle specifications screen.
47. Now press the "Close session" ICON (lower left hand side of screen, 3rd ICON) and press "delete (deletes session)". Press tick.
48. Disconnect WDS cable. PCM is now programmed with the latest calibration. Roadtest vehicle to relearn Keep Alive Memory (KAM).
49. Go back to REPAIR PROCEDURE Step 5.

**Procedure 2**

(For 3.0L vehicles with PCMs that have tear tag numbers of SJC0, SJC1, SJC2, HQP1, HQP2, HQP3, RKG0, BAR0, or BAR1)

**Note:** When performing this procedure, if the WDS PTU is not docked and connected to 115V-120V, we recommend that a battery charger be installed on the vehicle battery and turned ON to a maximum charge of no more than 20 AMPS to keep the vehicle battery up to capacity. If you exceed 20 AMPS it will damage the WDS PTU.

1. Connect WDS DLC cable to vehicle's DLC connector (lower portion of dash in front of driver).
2. Press "16 PIN", "All except those below", and then press tick.
3. Screen shows cable hookup. Turn ignition switch to ON. Press Tick.
4. Screen shows WDS communicating with PCM "progress bar" and "Operation in progress".
5. Wait until WDS finishes collection of PCM information. (hard drive light quits flashing). Then the "Vehicle Specification" screen appears with VIN # information. It asks you "Is this correct? Yes or No?" Press "Yes" if information is correct.
6. Screen appears to fill out R.O. information and mileage. Fill out information and then press tick. Or skip this by pressing tick.
7. **On certain tear tag PCM's ONLY**, screen will appear showing the "Standard Equipment Module". Press "Exit", then tick.
8. **For all other PCM tear tag numbers**, screen now return to the "Vehicle Specification".
9. Now press the "tools" tab on the top, then "Module Programming". Then press tick.
10. Screen will show "Please Wait." then another menu appears:
  - Programmable Module Installation
  - Module Reprogramming
  - Programmable Parameters
11. Press "Module Reprogramming" then PCM, then press tick.
12. Screen shows "A later calibration is available, P/N 1U7A-12A650-AYD filename: DOAR63W OR it will show 2U7A-12A650-CRB Filename: DOAR63Y OR it will show 3L8A-12A650-BC Filename: DOAV535. Do you want to program the PCM with it. Press YES.
13. Screen will say to ensure battery is good to run test. Then press Tick.
14. Screen will now say that KOEO test will be run before reprogramming to check for hard faults. Press tick.
15. Screen now shows self test preparation screen. Insure that all parameters are met then press tick.
16. Screen now shows "Performing test-Please Wait"
17. Screen will now show if any codes are stored.

**NOTE:** If any codes are stored they need to be addressed before recalibration. If no codes are stored proceed to next line.
18. If No Codes are stored press "EXIT". Then the tick mark.
19. Screen now shows" Set ignition switch to the OFF position". Do this and press tick.

20. Screen shows "Remove the fuses for fuel pump and cooling fans as this may cause interference and battery drain during the programming process". Do this and press Tick.

**Note:** There are two 50 amp fuses (on 3.0L) labeled "Main Fan" and "Add Fan". Remove only the 50 Amp fuses to deactivate the fans. Fuel pump is a mini fuse 20 amp (position #6) at front end of fuse box.

21. Screen shows "Set ignition switch to the ON position". Do this.

22. Screen shows "Downloading data" box with "progress bar". Please wait 2-3 minutes.

23. Screen now shows "Set ignition switch to the OFF position". Do this and press tick.

24. Screen now shows "Set ignition switch to the ON position". Do this and press tick.

25. Screen now shows "Set ignition switch to the OFF position". Do this and press tick.

26. Screen shows "Calibration has been loaded and checked". Press tick.

27. Screen shows "Re-install fuses for fuel pump and cooling fans". Do this, then press tick.

28. Screen shows "Obtain a PCM label and fill in the PCM data shown with the date on the WDS screen. Calibration P/N is: 1U7A-12A650-AYD, 2U7A-12A650-CRB, or 3L8A-12A650-BC. Install PCM label next to the vehicle emission label on the hood.

29. Screen shows "Start engine. Do not depress throttle". Do this and press tick.

30. Screen shows "operation successful- procedure complete". Press Tick.

31. Screen now shows "Turn key off" - Do this then press tick.

32. Vehicle PCM calibration is now updated.

33. Disconnect WDS cable. Roadtest vehicle to relearn Keep Alive Memory (KAM).

34. Go back to REPAIR PROCEDURE Step 5.