

PE12-019

MADZA

9/6/2012

APPENDIX 3 SUBJECT
VEHICLES

Consumer Reports

MAZDA CAC

VOQ MAZDA PAGE 305

DAMAGE CLAIM PAGE 469

LAWSUIT PAGE 524

PE12-019

Mazda

9-6-2012

REQUEST NUMBER THREE
DOCUMENTS (SUBJECT)

Consumer Reports

Mazda CAC

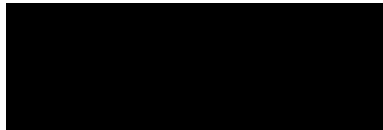

Logout Tools Help Welcome Paul Winovitch EPIPHANY

Home Requests Vehicle Summary Vehicle Summary Request - Recall Inquiry Request - veh jumps forward Request - Recall Inquiry Vehicle Summary Vehicle Summary Vehicle Summary Request

Request Save New Refresh Escalate Create New Task Actions History

inq on recall

Account/Interaction Summary

<p>██████████</p> <p>██████████</p> <p>CINCINNATI OH 45██████████</p> <p>Phone number unknown</p> <p>E-mail address unknown</p>	<p>Current Vehicles(1)</p> <p>Requests(1)</p> <p>Open Requests(0)</p> <p>Pending Dealer Requests(0)</p>
---	---

ID: ██████████ Created: 8/23/05 6:25 AM by: Karen Oeffinger Updated: 8/23/05 6:26 AM by: Karen Oeffinger

Assigned Agent: <input type="text" value="Item To Closed"/>	Create Date: <input type="text" value="8/23/05"/>	Status: <input type="text" value="Closed"/>	Date Closed: <input type="text" value="8/23/05 6:26 AM"/>	Satisfaction Code: <input type="text" value="Satisfied"/>	Escalated: <input type="checkbox"/>
Customer: <input type="text" value="██████████"/>	Assigned Region: <input type="text" value="Midwest Region"/>	Source: <input type="text" value="Special Campaign"/>			
Description: <input type="text" value="inq on recall"/>	Responsible Dealer: <input type="text"/>	Responsible Dealer Name: <input type="text"/>	Responsible Dealer Phone: <input type="text"/>		
Notes: <input type="text" value="cust sts he saw on the internet that his veh had a recall and wanted to know what he needs to do"/>	Resolving Dealer: <input type="text"/>	Resolving Dealer Name: <input type="text"/>	Resolving Dealer Phone: <input type="text"/>	DSA: <input type="text"/>	
	Add'l Requests: <input type="text" value="No"/>	Hotline: <input type="text" value="No"/>	Campaign: <input type="text" value="Yes"/>		
	Goodwill: <input type="text" value="No"/>	Branded: <input type="text" value="No"/>	Log #: <input type="text"/>		

Primary Contact Code

Type: <input type="text" value="INQUIRY (3)"/>	Reason 1: <input type="text" value="RECALL/BSP (5)"/>	Reason 2: <input type="text" value="-----"/>
Component: <input type="text" value="-----"/>	Category: <input type="text" value="-----"/>	Comment: <input type="text" value="-----"/>

VIN: Mileage: Model: Year: Transmission: Previous Repair Attempt: [Validate vehicle](#)

Agent Notes | Contact Codes | Goodwill | Requests | CRV | CC Case Detail | Attachments | Tasks | Knowledge Documents | Emails | Audit Trails | Send To Dealer History

Agent Notes 1-1 of 1

Created Date: 8/23/05 6:26 AM	Created By: Karen Oeffinger	Type: Agent Closing Request Note	Text: provided cust with recall info and adv to make appt at dir thanked	Delete: <input type="button" value="X"/>
-------------------------------	-----------------------------	----------------------------------	--	--

Notepad

Logout Tools Help Welcome Paul Winovitch EPIPHANY

Home Requests Vehicle Summary Vehicle Summary Request - Recall Inquiry Request - veh jumps forward Request - Recall Inquiry Vehicle Summary Vehicle Summary Vehicle Summary Request

Save New Refresh Escalate Create New Task Actions History

Stalling cond

Account/Interaction Summary

PHILADELPHIA PA	Current Vehicles(2)
Phone number unknown	Requests(1)
E-mail address unknown	Open Requests(0)
	Pending Dealer Requests(0)

ID: [redacted] Created: 8/18/06 2:47 PM by: Jerry Sanchez Updated: 2/16/07 7:38 AM by: William Zdan

Assigned Agent: [redacted] Create Date: 8/18/06 Status: Closed Date Closed: 2/16/07 7:38 AM Satisfaction Code: Satisfied Escalated: [checkbox]

Customer: [redacted] Assigned Region: Northeast Region Source: Customer Mediation/Legal

Description: Stalling cond Responsible Dealer: 50359 Responsible Dealer Name: PACIFICO MAZDA Responsible Dealer Phone: 215-3657400

Notes: 8-18-06 - Received Regional Assist Request from Bob FOM. Resolving Dealer: 50359 Resolving Dealer Name: PACIFICO MAZDA Resolving Dealer Phone: 215-3657400 DSA: Yes

Add'l Requests: No Hotline: Yes Campaign: No
 Goodwill: No Branded: No Log #: 008863

Primary Contact Code
 Type: PRODUCT RELATED COMPLAINT (1) Reason 1: PRODUCT (1) Reason 2: LEMON/LLEGAL (1)
 Component: ENGINE Category: PISTON ENGINE (b) Comment: STALLS/WILL RESTART (05)

VIN: 4F2YZ02Z76K Mileage: 4,000 Model: TRB TRIBUTE Year: 2006 Transmission: Automatic Previous Repair Attempt: [checkbox] Vehicle Vehicle

Agent Notes Contact Codes Goodwill Requests CRV CC Case Detail Attachments Tasks Knowledge Documents Emails Audit Trails Send To Dealer History

CRV Detail

CRV Base Information:			Resale Details:			Financials:		
Log Number: 008863	CRV Type: LEMON LAW	Reason CRV: VOLUNTARY	KBB Price:	kbb Price Date: 9/12/06	Condition:	Repurchase Amount: 17,880	Voluntary Trade Assist Amt:	
CRV Status: Sold	Repurchase: Yes	Tradeout: Yes	Committed To:	Hold Until:	Attorney Fee/Legal/Misc:	Total Repurch Amt: \$17880.0		
	No	No	Sold To:	Resale State:	Mileage:	Resale Amount:		

Notepad Clear

* Buyback vehicle

PE12-019

Mazda

9-6-2012

REQUEST NUMBER THREE
DOCUMENTS (SUBJECT)

Consumer Reports

Mazda CAC

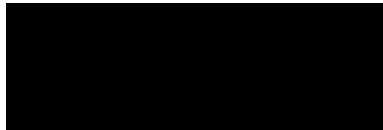



Concern Driven Reporting

Report Detail

Note: Field which are grayed (ghosted) are currently being mapped to the data warehouse. They are not presently being populated.

ECI Record		Source Code	MAZDA CAC
------------	--	-------------	-----------

Commodity Assignment

Commodity	electrical-instrument/display-warning chimes/lights	Symptom	burned out
Commodity	electrical-instrument/display-warning chimes/lights	Symptom	function-malfunction/inoperative
Commodity	electrical-instrument/display-warning chimes/lights	Symptom	mod-driving condition-at cruise
Commodity	electrical-instrument/display-warning chimes/lights	Symptom	mod-driving condition-while driving
Commodity	electrical-instrument/display-warning chimes/lights	Symptom	mod-indicator light/warning chime on
Significant Event		Verified	N

Tread Information

Reported in Tread Quarter	Q3 2003
---------------------------	---------

Report Details

Source Claim Key		Warranty Component Classification (WCC)	
Corporate Product Systems Classification (CPSC)		Time in Service	30
Customer Condition Code		V Function Group (VFG)	
Source System Program Type		Repair/Report/Paid Date	09-Sep-2003
Version Series Code	AAAAX	Load Date	14-Sep-2003
Causal Part Prefix-Base-Suffix	-	Dealer Code	UNKNOW
Causal Part Name	unknown	Dealer Name	
Non Causal Part Prefix-Base-Suffix		Dealer City	
Non Causal Part Numbers		Dealer State/Province	
Fault Code		Dealer Country	UNK
Diagnostic Trouble Code		Dealer Phone Number	
Labor Operation Code		Attachment	
Communication Type		VOQ Component Description Code	
Maintenance Date	14-Sep-2003		

Customer Comment	RCVD LTR FROM CST, STS PURCH VEH W/OUT CRUISE CONTROL, STS DLR HAD INDEP INSTALL CRUISE CONTROL. STS TOOK VEH TO DLR MULTIPLE TIMES FOR CHK ENG LIGHT. STS DLR KEPT REPLACING PARTS. STS NOW VEH OOW AND SHE TOOK VEH TO INDEP AND PROB WAS WITH CRUISE CONTROL INSTALLATION. REQ REIMB.
Technician Comment	MAILED LTR TO ADV TO ADDRESS ISSUE WITH DLR AS CONCERN WITH CRUISE CONTROL INSTALLATION IS NOT FACTORY RELATED AS IT WAS DONE BY DLR/INDEP.
CQIS Recommendations	

Tire Information

Tire Manufacturer	Unknown	Tire Size	Unknown
Tire Brand Series		Wheel	
DOT Left Front		DOT Right Front	
DOT Left Rear		DOT Right Rear	
DOT Left Inner		DOT Right Inner	
DOT Spare			

Vehicle Information

VIN	4F2YU07181K	Engine Serial Number	460374038
Model Year	2001	Engine Description	3.0L DOHC EGI V6 NA*GAS
Transmission	4 SPD AUTO TRANS MAZDA CD4E	Vehicle Description	TRIBUTE
Body Cab Style	CA WE 5 DOOR LIGHT TRUCK	Drive Line	2 WHL L/H FRONT DRIVE
Production Date	27-Jul-2000	Retail Sale Indicator Code	
Plant Description	KANSAS CITY PLANT BUILD	Required Vehicle	
Build Region		Warranty Start Date	30-Mar-2001
Build Country Code		Transmission Serial Number	
Mileage	0	Vehicle Axle Ratio	
Vehicle Restraint Code			

Disclaimer:

This data is for use as one of several potential "awareness" indicators for the Ford Motor Co. Enhanced Concern Identification System. It is unverified, draft, summary data generated from a computer "word search" of customer and technician symptom comments. Supplier data, technician and customer comments are unverified and actual root cause of any potential issue is not established by this summary.

[Contact ODRHELP](#)

Copyright 2001 Ford Motor Co All Rights Reserved

PE12-019

Mazda

9-6-2012

REQUEST NUMBER THREE
DOCUMENTS (SUBJECT)

Consumer Reports

Mazda CAC

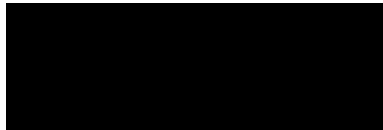



Concern Driven Reporting

Report Detail

Note: Field which are grayed (ghosted) are currently being mapped to the data warehouse. They are not presently being populated.

ECI Record		Source Code	MAZDA CAC
------------	--	-------------	-----------

Commodity Assignment			
Commodity	powertrain-engine	Symptom	function-malfunction/inoperative
Commodity	powertrain-engine	Symptom	mod-intermittent/random
Commodity	powertrain-engine	Symptom	no keyword found
Commodity	powertrain-engine	Symptom	pedal concerns-accelerator pedal
Commodity	powertrain-engine	Symptom	repair-prior repair mentioned
Commodity	powertrain-engine	Symptom	sticks/binds/grabs
Significant Event		Verified	N

Tread Information	
Reported in Tread Quarter	Q1 2005

Report Details			
Source Claim Key		Warranty Component Classification (WCC)	
Corporate Product Systems Classification (CPSC)		Time in Service	46
Customer Condition Code		V Function Group (VFG)	
Source System Program Type		Repair/Report/Paid Date	10-Jan-2005
Version Series Code	AAAQK	Load Date	13-Feb-2005
Causal Part Prefix-Base-Suffix	- -	Dealer Code	23716
Causal Part Name	unknown	Dealer Name	HENNESSY MAZDA
Non Causal Part Prefix-Base-Suffix		Dealer City	MORROW
Non Causal Part Numbers		Dealer State/Province	GA
Fault Code		Dealer Country	USA
Diagonstic Trouble Code		Dealer Phone Number	
Labor Operation Code		Attachment	
Communication Type		VOQ Component Description Code	
Maintenance Date	13-Feb-2005		

Customer Comment	CUST STS ACCELLATOR STICKS. CUST STS ISSUE HAS BEEN NOTICABLE SINCE PURCHASE. CUST STS WANTS ISSUE REPAIRED AT NO COST TO HER. CUST STS SVA [REDACTED] CUST STS VERY IRRATIC WHEN VEH STICKS/LURCH. CUST STS DLR UNABLE TO DUP/DIAG.		
Technician Comment	0012005 01 10CRPP644 REQ DESC INTERMITTENT ACCELLATOR STICKING ADV CUST TO HAVE DLR DIAG ISSUE. ADV CUST WILL CONTACT DLR ON HER BEHALF. THANKED. TT SVM BOB HURST (678) 898 2549, ADV OF CUST ISSUE, ADV VEH MODEL YR NOT PART OF RECALL. REQ SVM RESEARCH VEH HISTORY AND CONTACT TECH LINE FOR REPAIR ASSIST. ADV MAY BE ABLE TO ASSIST IF NECESSARY. NO FURTHER CONTACT FROM CUST.		
CQIS Recommendations			

Tire Information			
Tire Manufacturer	Unknown	Tire Size	Unknown
Tire Brand Series		Wheel	
DOT Left Front		DOT Right Front	
DOT Left Rear		DOT Right Rear	
DOT Left Inner		DOT Right Inner	
DOT Spare			

Vehicle Information			
VIN	4F2YU09191K [REDACTED]	Engine Serial Number	816550086
Model Year	2001	Engine Description	3.0L DOHC EGI V6 NA*GAS
Transmission	4 SPD AUTO TRANS MAZDA CD4E	Vehicle Description	TRIBUTE
Body Cab Style	CA WE 5 DOOR LIGHT TRUCK	Drive Line	2 WHL L/H FRONT DRIVE
Production Date	13-Mar-2001	Retail Sale Indicator Code	
Plant Description	KANSAS CITY PLANT BUILD	Reaquired Vehicle	
Build Region		Warranty Start Date	06-Apr-2001
Build Country Code		Transmission Serial Number	
Mileage	85000	Vehicle Axle Ratio	
Vehicle Restraint Code			

Disclaimer:

This data is for use as one of several potential "awareness" indicators for the Ford Motor Co. Enhanced Concern Identification System. It is unverified, draft, summary data generated from a computer "word search" of customer and technician symptom comments. Supplier data, technician and customer comments are unverified and actual root cause of any potential issue is not established by this summary.

[Contact ODRHELP](#)

Copyright 2001 Ford Motor Co All Rights Reserved

PE12-019

Mazda

9-6-2012

REQUEST NUMBER THREE
DOCUMENTS (SUBJECT)

Consumer Reports

Mazda CAC

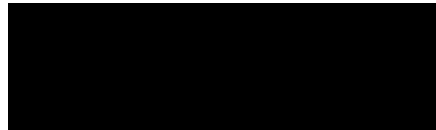



Concern Driven Reporting

Report Detail

Note: Field which are grayed (ghosted) are currently being mapped to the data warehouse. They are not presently being populated.

ECI Record		Source Code	MAZDA Care Surveys
------------	--	-------------	--------------------

Commodity Assignment

Commodity	powertrain-engine-accel pedal/linkage/controls	Symptom	mod-intermittent/random
Commodity	powertrain-engine-accel pedal/linkage/controls	Symptom	pedal concerns-accelerator pedal
Significant Event		Verified	N

Tread Information

Tread Category Code	18	Tread Category Description	speed control
Reported in Tread Quarter	Q1 2006		

Report Details

Source Claim Key		Warranty Component Classification (WCC)	
Corporate Product Systems Classification (CPSC)		Time in Service	37
Customer Condition Code		V Function Group (VFG)	
Source System Program Type		Repair/Report/Paid Date	14-Jan-2006
Version Series Code	AAAA5	Load Date	16-Feb-2006
Causal Part Prefix-Base-Suffix	-	Dealer Code	23877
Causal Part Name	NOT PROVIDED BY SOURCE	Dealer Name	ACCARDI MAZDA
Non Causal Part Prefix-Base-Suffix		Dealer City	LAKE CITY
Non Causal Part Numbers		Dealer State/Province	FL
Fault Code		Dealer Country	USA
Diagonstic Trouble Code		Dealer Phone Number	3867526933
Labor Operation Code		Attachment	
Communication Type		VOQ Component Description Code	
Maintenance Date	16-Feb-2006		

Customer Comment	After receiving a recall notice from Mazda about my 2003 Tribute, I brought it to Eddie Accardi Mazda in Lake City Florida, where I purchased the vehicle and routinely bring it for periodic oil changes and tire rotations. I was told by the service writer that my vehicle was not on the recall list and no recall service was necessary. About two months later I experienced a runaway engine while on the road and fortunately was able to drive the vehicle with much difficulty to Duval Mazda in Gainesville, Florida where the accelerator linkage was replaced as a recall item. This was a scary and dangerous experience as a result of Accardi Mazda's service writer's negligence. Dr. [REDACTED]		
Technician Comment			
CQIS Recommendations			

Tire Information

Tire Manufacturer	Unknown	Tire Size	Unknown
Tire Brand Series		Wheel	
DOT Left Front		DOT Right Front	
DOT Left Rear		DOT Right Rear	
DOT Left Inner		DOT Right Inner	
DOT Spare			

Vehicle Information

VIN	4F2YZ04163K [REDACTED]	Engine Serial Number	
Model Year	2003	Engine Description	3.0L DOHC EGI V6 NA*G DSP2967
Transmission	4 SPD AUTO TRANS MAZDA CD4E	Vehicle Description	TRIBUTE
Body Cab Style	CA WE 5 DOOR LIGHT TRUCK	Drive Line	2 WHL L/H FRONT DRIVE
Production Date	11-Dec-2002	Retail Sale Indicator Code	
Plant Description	KANSAS CITY PLANT BUILD	Required Vehicle	
Build Region		Warranty Start Date	23-Jan-2003
Build Country Code		Transmission Serial Number	
Mileage	0	Vehicle Axle Ratio	
Vehicle Restraint Code			

Disclaimer:

This data is for use as one of several potential "awareness" indicators for the Ford Motor Co. Enhanced Concern Identification System. It is unverified, draft, summary data generated from a computer "word search" of customer and technician symptom comments. Supplier data, technician and customer comments are unverified and actual root cause of any potential issue is not established by this summary.

[Contact ODRHELP](#)

Copyright 2001 Ford Motor Co All Rights Reserved

PE12-019

Mazda

9-6-2012

REQUEST NUMBER THREE
DOCUMENTS (SUBJECT)

Consumer Reports

Mazda CAC

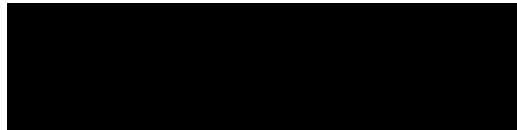



Concern Driven Reporting

Report Detail

Note: Field which are grayed (ghosted) are currently being mapped to the data warehouse. They are not presently being populated.

ECI Record		Source Code	GCQIS Mazda
------------	--	-------------	-------------

Commodity Assignment			
Commodity	powertrain-engine	Symptom	engine power-misfire/runs rough
Commodity	powertrain-engine	Symptom	engine rpm surge/flare
Commodity	powertrain-engine	Symptom	mod-driving condition-at idle
Commodity	powertrain-engine	Symptom	mod-driving condition-on acceleration
Commodity	powertrain-engine	Symptom	pedal concerns-accelerator pedal
Commodity	powertrain-engine	Symptom	sticks/binds/grabs
Commodity	powertrain-engine	Symptom	unintended acceleration
Commodity	powertrain-engine-accel pedal/linkage/controls	Symptom	engine rpm surge/flare
Commodity	powertrain-engine-accel pedal/linkage/controls	Symptom	mod-driving condition-on acceleration
Commodity	powertrain-engine-accel pedal/linkage/controls	Symptom	pedal concerns-accelerator pedal
Commodity	powertrain-engine-accel pedal/linkage/controls	Symptom	sticks/binds/grabs
Significant Event		Verified	N

Tread Information	
Reported in Tread Quarter	Q2 2002

Report Details			
Source Claim Key		Warranty Component Classification (WCC)	
Corporate Product Systems Classification (CPS)		Time in Service	
Customer Condition Code		V Function Group (VFG)	
Source System Program Type	P	Repair/Report/Paid Date	14-May-2002
Version Series Code	AAAQK	Load Date	04-Jan-2003
Causal Part Prefix-Base-Suffix	-Unknown-	Dealer Code	8409L
Causal Part Name	Unknown	Dealer Name	FORD MOTOR CO PROD EVAL SURVEY
Non Causal Part Prefix-Base-Suffix		Dealer City	DEARBORN
Non Causal Part Numbers		Dealer State/Province	MI
Fault Code		Dealer Country	USA
Diagnostic Trouble Code		Dealer Phone Number	
Labor Operation Code		Attachment	N
Communication Type		VOQ Component Description Code	
Maintenance Date	18-Mar-2006		

Customer Comment	VEHICLE HESITATES/SURGES WHEN STARTING FROM STOP. IT SEEMS AS IF THROTTLE PLATE MAY STICK
Technician Comment	
CQIS Recommendations	

Tire Information			
Tire Manufacturer	Unknown	Tire Size	Unknown
Tire Brand Series		Wheel	
DOT Left Front		DOT Right Front	
DOT Left Rear		DOT Right Rear	
DOT Left Inner		DOT Right Inner	
DOT Spare			

Vehicle Information			
VIN	4F2CU08172K	Engine Serial Number	301995087
Model Year	2002	Engine Description	3.0L DOHC EGI V6 NA*GAS
Transmission	4 SPD AUTO TRANS MAZDA CD4E	Vehicle Description	TRIBUTE
Body Cab Style	CA WE 5 DOOR LIGHT TRUCK	Drive Line	4 WHL L/H PART TIME DRIVE
Production Date	23-Feb-2002	Retail Sale Indicator Code	
Plant Description	KANSAS CITY PLANT BUILD	Required Vehicle	
Build Region		Warranty Start Date	20-Mar-2002
Build Country Code		Transmission Serial Number	
Mileage	2500	Vehicle Axle Ratio	
Vehicle Restraint Code			

Disclaimer:

This data is for use as one of several potential "awareness" indicators for the Ford Motor Co. Enhanced Concern Identification System. It is unverified, draft, summary data generated from a computer "word search" of customer and technician symptom comments. Supplier data, technician and customer comments are unverified and actual root cause of any potential issue is not established by this summary.

[Contact ODRHELP](#)

Copyright 2001 Ford Motor Co All Rights Reserved

PE12-019

Mazda

9-6-2012

REQUEST NUMBER THREE
DOCUMENTS (SUBJECT)

Consumer Reports

Mazda CAC

ECi

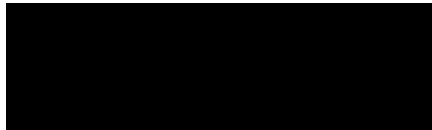



Concern Driven Reporting

Report Detail

Note: Field which are grayed (ghosted) are currently being mapped to the data warehouse. They are not presently being populated.

ECI Record		Source Code	MAZDA CAC
------------	--	-------------	-----------

Commodity Assignment			
Commodity	powertrain-engine—	Symptom	no keyword found
Commodity	powertrain-engine-accel pedal/linkage/controls—	Symptom	loose
Commodity	powertrain-engine-accel pedal/linkage/controls—	Symptom	misaligned/out of position/adjustment/poor fit
Commodity	powertrain-engine-accel pedal/linkage/controls—	Symptom	nvh-noisy operation
Commodity	powertrain-engine-accel pedal/linkage/controls—	Symptom	pedal concerns-accelerator pedal
Commodity	powertrain-engine-accel pedal/linkage/controls—	Symptom	sticks/binds/grabs
Commodity	powertrain-engine-air induction-throttle body-	Symptom	loose
Commodity	powertrain-engine-air induction-throttle body-	Symptom	misaligned/out of position/adjustment/poor fit
Commodity	powertrain-engine-air induction-throttle body-	Symptom	nvh-noisy operation
Commodity	powertrain-engine-air induction-throttle body-	Symptom	sticks/binds/grabs
Significant Event		Verified	N

Tread Information

Report Details

Source Claim Key		Warranty Component Classification (WCC)	
Corporate Product Systems Classification (CPSC)		Time in Service	21
Customer Condition Code		V Function Group (VFG)	
Source System Program Type		Repair/Report/Paid Date	08-Apr-2003
Version Series Code	AAAAX	Load Date	11-Jun-2003
Causal Part Prefix- Base - Suffix	- -	Dealer Code	23235
Causal Part Name	unknown	Dealer Name	PARKS MAZDA
Non Causal Part Prefix-Base-Suffix		Dealer City	HIGH POINT
Non Causal Part Numbers		Dealer State/Province	NC
Fault Code		Dealer Country	USA
Diagonstic Trouble Code		Dealer Phone Number	3368867889
Labor Operation Code		Attachment	
Communication Type		VOQ Component Description Code	
Maintenance Date	30-Jun-2003		

Customer Comment THROTTLE BODY WHERE THE INTAKE HOOKS UP IS STICKING.CST STS DLR CANT FIX IT. CST STS THEY TELL HIM ITS NOT COVERED UNDER WTTY AND THEY WANT TO CHARGE HIM \$179 FOR REPAIR. CST STS HE CAN FIX IT FOR \$2 WITH A CAN OF LUBRUCANT. CST STS HE MAY GO TO ANOTHER DLR FOR HELP. CST STS HIS REAR HATCHBCKA DOOR RATTLES AND THE DLR ONLY PUTS GREESE ON IT TO FIX IT. CST WANTS TO KNOW WHAT HAPPENS WHEN HE GOES OUTSIDE WTTY.

Technician Comment 0012003 04 08CRPC407 AT ATTN SVM PLEASE CLOSE WITH RESOLUTION. THANKS, GRANT ADVISED CUSTOMER THAT THROTTLE BODY LINKAGE STICKING DUE TO CARBON BUILD UP DUE TO FUEL. THIS IS NOT A MFG. DEFECT THEREFORE IT IS NOT COVERED UNDER WARRANTY. ALSO, DISCUSSED REAR HATCH DOOR RATTLE THAT THERE IS AN M TIP OUT ABOUT LUBRICATING THE STRICKER AND ADJUSTING IT. WE HAVE DONE THIS SEVERAL TIMES AND GAVE A TUBE OF LUBRICATE. THIS ALL MAZDA HAS AT THIS TIME ATTN SVM PLEASE CLOSE WITH RESOLUTION. THANKS, GRANT

CQIS Recommendations

Tire Information

Tire Manufacturer	Unknown	Tire Size	Unknown
Tire Brand Series		Wheel	
DOT Left Front		DOT Right Front	
DOT Left Rear		DOT Right Rear	
DOT Left Inner		DOT Right Inner	
DOT Spare			

Vehicle Information

VIN	4F2YU07181K	Engine Serial Number	866890087
Model Year	2001	Engine Description	3.0L DOHC EGI V6 NA*GAS
Transmission	4 SPD AUTO TRANS MAZDA CD4E	Vehicle Description	TRIBUTE
Body Cab Style	CA WE 5 DOOR LIGHT TRUCK	Drive Line	2 WHL L/H FRONT DRIVE
Production Date	12-Apr-2001	Retail Sale Indicator Code	
Plant Description	KANSAS CITY PLANT BUILD	Reaquired Vehicle	
Build Region		Warranty Start Date	16-Aug-2001
Build Country Code		Transmission Serial Number	
Mileage	22000	Vehicle Axle Ratio	
Vehicle Restraint Code			

Disclaimer:

This data is for use as one of several potential "awareness" indicators for the Ford Motor Co. Enhanced Concern Identification System. It is unverified, draft, summary data generated from a computer "word search" of customer and technician symptom comments. Supplier data, technician and customer comments are unverified and actual root cause of any potential issue is not established by this summary.

[Contact ODRHELP](#)

Copyright 2001 Ford Motor Co All Rights Reserved

PE12-019

Mazda

9-6-2012

REQUEST NUMBER THREE
DOCUMENTS (SUBJECT)

Consumer Reports

Mazda CAC

ECI

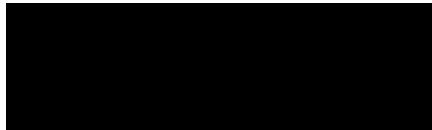



Concern Driven Reporting

Report Detail

Note: Field which are grayed (ghosted) are currently being mapped to the data warehouse. They are not presently being populated.

ECI Record		Source Code	MAZDA CAC
------------	--	-------------	-----------

Commodity Assignment

Commodity	powertrain-engine	Symptom	no keyword found
Commodity	powertrain-engine	Symptom	pedal concerns-accelerator pedal
Commodity	powertrain-engine	Symptom	retract-does not retract
Commodity	powertrain-engine	Symptom	sticks/binds/grabs
Commodity	powertrain-engine-accel pedal/linkage/controls	Symptom	function-malfunction/inoperative
Commodity	powertrain-engine-accel pedal/linkage/controls	Symptom	mod-intermittent/random
Commodity	powertrain-engine-accel pedal/linkage/controls	Symptom	no problem found
Commodity	powertrain-engine-accel pedal/linkage/controls	Symptom	pedal concerns-accelerator pedal
Commodity	powertrain-engine-accel pedal/linkage/controls	Symptom	sticks/binds/grabs
Significant Event		Verified	N

Tread Information

Report Details

Source Claim Key		Warranty Component Classification (WCC)	
Corporate Product Systems Classification (CPSC)		Time in Service	19
Customer Condition Code		V Function Group (VFG)	
Source System Program Type		Repair/Report/Paid Date	23-Jun-2003
Version Series Code	AAAQK	Load Date	24-Aug-2003
Causal Part Prefix-Base-Suffix	-	Dealer Code	60207
Causal Part Name	unknown	Dealer Name	MAZDA OF BEDFORD
Non Causal Part Prefix-Base-Suffix		Dealer City	BEDFORD
Non Causal Part Numbers		Dealer State/Province	OH
Fault Code		Dealer Country	USA
Diagnostic Trouble Code		Dealer Phone Number	4404392323
Labor Operation Code		Attachment	
Communication Type		VOQ Component Description Code	
Maintenance Date	24-Aug-2003		

Customer Comment CUST STS HE TOOK HIS VEH TO DLR FOR A STICKING THROTTLE. STS HE WAS CHAGED TO A THROTTLE BODY CLEANING AND IT IS STICKING AGAIN (WAS CLEANED 3/03). ALSO SEAT BELT WILL NOT RETRACT.

Technician Comment SPOKE WITH JAMES STILL FEELS THROTTLE STICKS. UNHAPPY WITH OUR SERVICE AND HAS APPOINTMENT SET WITH FRED VINCENT MAZDA FOR DIAGNOSIS. OFFERED TO LOOK AGAIN AND DID NOT WANT TO COME BACK TO OUR SERVICE DEPARTMENT AT THIS TIME. OFFERED TO HANDLE SITUATION PERSONALLY BUT HE DECLINED. TOLD HIM I WAS AT HIS DISPOSAL IF FRED VINCENT DID NOT CLEAR UP ISSUE ATTN SVM PLEASE REVIEW FILE AND CLOSE WITH YOUR FINDINGS. THANK YOU, HEATHER B. 949/727 6435 0022003 06 30CRPC399 SPOKE TO SVA DAVID. HE SAID HAVE CUST CALL THEM FOR APPOINTMENT BUT THEY ARE BOOKED PRETTY SOLID DUE TO 4TH JULY WEEKE NED. STS BETTER OFF GETTING IN NEXT WEEK. THANKED. ADV I'LL NOTIFY CUST. ADV CUST OF INFO ABOVE. CUST THANKED FOR CONTACT PERSON. GAVE VDN#. AT ATTN SVM PLEASE REVIEW FILE AND CLOSE WITH YOUR FINDINGS. THANK YOU, HEATHER B. 949/727 6435 0012003 06 30CRPC399 CUSTOMER CALLED TO FOLLOW UP WITH CRPC444. WAS WAITING FOR HIM TO CALL FRED VINCENT MAZDA TO SET UP AN APPOINTMENT FOR 2ND OPINION. STS THAT MAZDA OF BEDFORD TOLD HIM THAT THE STICKING THROTTLE OR GAS PEDAL WAS OPERATING AS DESIGNED AND D SAID THE INTERMITTENT PROBLEM W/THE SEATBELT NOT RETRACTING WAS NOT DUPLICATED. CUST STS HE WOULD LIKE TO GET HIS OIL CHANGED & WOULD LIKE TO SEE IF FRED VINCENT COULD PERFORM THE SERVICE AND ALSO LOOK AT THESE PROBS AS A 2ND OPINION. CALLED FRED VINCENT MAZDA INQ IF THEY TAKE APPOINTMENTS

CQIS Recommendations

Tire Information

Tire Manufacturer	Unknown	Tire Size	Unknown
Tire Brand Series		Wheel	
DOT Left Front		DOT Right Front	
DOT Left Rear		DOT Right Rear	
DOT Left Inner		DOT Right Inner	
DOT Spare			

Vehicle Information

VIN	4F2YU09122K	Engine Serial Number	056419087
Model Year	2002	Engine Description	3.0L DOHC EGI V6 NA*GAS
Transmission	4 SPD AUTO TRANS MAZDA CD4E	Vehicle Description	TRIBUTE
Body Cab Style	CA WE 5 DOOR LIGHT TRUCK	Drive Line	2 WHL L/H FRONT DRIVE
Production Date	11-Sep-2001	Retail Sale Indicator Code	
Plant Description	KANSAS CITY PLANT BUILD	Required Vehicle	
Build Region		Warranty Start Date	30-Dec-2001
Build Country Code		Transmission Serial Number	
Mileage	15000	Vehicle Axle Ratio	
Vehicle Restraint Code			

Disclaimer:

This data is for use as one of several potential "awareness" indicators for the Ford Motor Co. Enhanced Concern Identification System. It is unverified, draft, summary data generated from a computer "word search" of customer and technician symptom comments. Supplier data, technician and customer comments are unverified and actual root cause of any potential issue is not established by this summary.

[Contact ODRHELP](#)

Copyright 2001 Ford Motor Co All Rights Reserved

PE12-019

Mazda

9-6-2012

REQUEST NUMBER THREE
DOCUMENTS (SUBJECT)

Consumer Reports

Mazda CAC

ECI

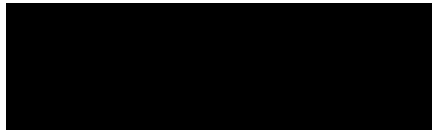



Concern Driven Reporting

Report Detail

Note: Field which are grayed (ghosted) are currently being mapped to the data warehouse. They are not presently being populated.

ECI Record		Source Code	MAZDA CAC
------------	--	-------------	-----------

Commodity Assignment

Commodity	powertrain-engine	Symptom	function-malfunction/inoperative
Commodity	powertrain-engine	Symptom	no keyword found
Commodity	powertrain-engine	Symptom	no problem found
Commodity	powertrain-engine-accel pedal/linkage/controls	Symptom	no keyword found
Commodity	powertrain-engine-air induction-throttle body-	Symptom	no keyword found
Significant Event		Verified	N

Tread Information

Reported in Tread Quarter	Q4 2003 Q1 2004
---------------------------	-----------------

Report Details

Source Claim Key		Warranty Component Classification (WCC)	
Corporate Product Systems Classification (CPSC)		Time in Service	27
Customer Condition Code		V Function Group (VFG)	
Source System Program Type		Repair/Report/Paid Date	18-Dec-2003
Version Series Code	AAAQK	Load Date	11-Jan-2004
Causal Part Prefix - Base - Suffix	- -	Dealer Code	61515
Causal Part Name	unknown	Dealer Name	CLIFF WALL MAZDA
Non Causal Part Prefix-Base-Suffix		Dealer City	GREEN BAY
Non Causal Part Numbers		Dealer State/Province	WI
Fault Code		Dealer Country	USA
Diagnostic Trouble Code		Dealer Phone Number	9204688898
Labor Operation Code		Attachment	
Communication Type		VOQ Component Description Code	
Maintenance Date	11-Jan-2004		

Customer Comment CST STS THAT HIS VEH HAS A PROB W/ THE THROTTLE. CST STS THAT DLR SAID HE NEEDS PART CLEANED. CST STS CLEANING WILL BE MORE THAN \$120. CST STS THAT HE HAD THIS DONE A YR AGO & MAZDA PAID FOR. CST STS HE FEELS DEFECT IN PART. CST STS MAZDA SHOULD COVER. CST STS WILL NOT BUY ANOTHER MAZDA IF HE HAS TO INCUR COST FOR CLEANING. CST STS CRAPPY CAR & CRAPPY DLR.

Technician Comment ATTN SVM ADV CST CARBON CLEANING IS MAINTENANCE ITEM & CST PAY. PLS CLOSE FILE UPON RESOLUTION W/ NOTES. THANK YOU, REBECCA 949.727.6849 EXPLAINED THAT THROTTLE BODY CLEANING WAS PART OF MAINTENCE. CUSTOMER DID NOT FEEL HE HAD TO PAY FOR MAINTENCE. SO WE WERE AT A STALEMATE. 0012003 12 18CRPC522 AT ATTN SVM ADV CST CARBON CLEANING IS MAINTENANCE ITEM & CST PAY. PLS CLOSE FILE UPON RESOLUTION W/ NOTES. THANK YOU, REBECCA 949.727.6849 PUT CST ON HOLD; CONTACTED DLR & TT SVM WHO ADV THAT CARBON BUILD UP ON THROTTLE BLADES & BODY ON 1/13/03. ADV CST IS NOT @ DLR NOW & HASN'T BEEN DIAG. ADV CLEANING WOULD BE PART OF 30K & NOT COVERED. THANKED. RELAYED INFO TO CST WHO SAID WENT IN LAST NIGHT & DIDN'T HAVE FORMALLY DIAG, BUT SA TOLD HIM THIS. ADV CST OF WHAT SVM SAID. CST STS GOING TO WRITE LE 0022003 12 18CRPC522 TTER ABOUT HOW BAD VEH IS & SEND TO THE PAPER. APOLOG FOR SIT. ADV CST REV AFTER FORMALLY DIAG. CST STS WILL WRITE LETTER. AGAIN APOLOG. ADV CST OF FILE # & VDN.

CQIS Recommendations	
----------------------	--

Tire Information

Tire Manufacturer	Unknown	Tire Size	Unknown
Tire Brand Series		Wheel	
DOT Left Front		DOT Right Front	
DOT Left Rear		DOT Right Rear	
DOT Left Inner		DOT Right Inner	
DOT Spare			

Vehicle Information

VIN	4F2YU09141K	Engine Serial Number	998812086
Model Year	2001	Engine Description	3.0L DOHC EGI V6 NA*GAS
Transmission	4 SPD AUTO TRANS MAZDA CD4E	Vehicle Description	TRIBUTE
Body Cab Style	CA WE 5 DOOR LIGHT TRUCK	Drive Line	2 WHL L/H FRONT DRIVE
Production Date	24-Jul-2001	Retail Sale Indicator Code	
Plant Description	KANSAS CITY PLANT BUILD	Required Vehicle	
Build Region		Warranty Start Date	17-Oct-2001
Build Country Code		Transmission Serial Number	
Mileage	29000	Vehicle Axle Ratio	
Vehicle Restraint Code			

Disclaimer:

This data is for use as one of several potential "awareness" indicators for the Ford Motor Co. Enhanced Concern Identification System. It is unverified, draft, summary data generated from a computer "word search" of customer and technician symptom comments. Supplier data, technician and customer comments are unverified and actual root cause of any potential issue is not established by this summary.

[Contact ODRHELP](#)

Copyright 2001 Ford Motor Co All Rights Reserved

PE12-019

Mazda

9-6-2012

REQUEST NUMBER THREE
DOCUMENTS (SUBJECT)

Consumer Reports

Mazda CAC

ECI

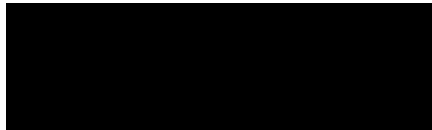



Concern Driven Reporting

Report Detail

Note: Field which are grayed (ghosted) are currently being mapped to the data warehouse. They are not presently being populated.

ECI Record		Source Code	MAZDA CAC
------------	--	-------------	-----------

Commodity Assignment

Commodity	powertrain-engine	Symptom	no keyword found
Commodity	powertrain-engine-accel pedal/linkage/controls	Symptom	engine power-stall
Commodity	powertrain-engine-accel pedal/linkage/controls	Symptom	function-malfunction/inoperative
Commodity	powertrain-engine-accel pedal/linkage/controls	Symptom	mod-driving condition-engine-cold
Commodity	powertrain-engine-accel pedal/linkage/controls	Symptom	mod-driving condition-while driving
Commodity	powertrain-engine-accel pedal/linkage/controls	Symptom	mod-intermittent/random
Commodity	powertrain-engine-accel pedal/linkage/controls	Symptom	mod-no indication (sudden)
Commodity	powertrain-engine-accel pedal/linkage/controls	Symptom	nvh-noisy operation
Commodity	powertrain-engine-accel pedal/linkage/controls	Symptom	pedal concerns-accelerator pedal
Commodity	powertrain-engine-accel pedal/linkage/controls	Symptom	sticks/binds/grabs
Commodity	powertrain-engine-air induction-throttle body-	Symptom	function-malfunction/inoperative
Commodity	powertrain-engine-air induction-throttle body-	Symptom	sticks/binds/grabs
Significant Event		Verified	N

Tread Information

Reported in Tread Quarter	Q4 2003 Q1 2004
---------------------------	-----------------

Report Details

Source Claim Key		Warranty Component Classification (WCC)	
Corporate Product Systems Classification (CPSC)		Time in Service	36
Customer Condition Code		V Function Group (VFG)	
Source System Program Type		Repair/Report/Paid Date	19-Dec-2003
Version Series Code	AAAAX	Load Date	22-Feb-2004
Causal Part Prefix - Base - Suffix	- -	Dealer Code	61549
Causal Part Name	unknown	Dealer Name	FOX MAZDA
Non Causal Part Prefix-Base-Suffix		Dealer City	GRAND RAPIDS
Non Causal Part Numbers		Dealer State/Province	MI
Fault Code		Dealer Country	USA
Diagnostic Trouble Code		Dealer Phone Number	6169565511
Labor Operation Code		Attachment	
Communication Type		VOQ Component Description Code	
Maintenance Date	22-Feb-2004		

Customer Comment	PER SUGGESTION FROM THE DLR THE CUST IS CALLING IN TO NOTIFY MAZDA OF CONCERNS WITH HIS VEHICLE. CUST SAYS THE VEHICLE WILL SUDDENLY STALL, SOMETIMES AT SLOW SPEEDS AND HE HAS TO RESTART THE VEHICLE. HE HAS BEEN TO THE DLR FOR THIS CONCERN BEFORE. CUST ALSO STATES THAT THE TRANS BANGS HARD INTO GEAR FIRST THING IN THE MORNING. CUST ALSO HAS A STICKY GAS PEDAL. CUST HAS APPT WITH DLR TO ADDRESS THESE ISSUES BUT WANTS DOCUMENTATION WITH MAZDA
Technician Comment	ATTN DCSM/SVM CUST IS CONCERNED THAT HIS ISSUES ARE NOT BEING DEALT WITH UNDER WARRANTY. CUST HAS AN APPOINTMENT WITH YOU NEXT MONDAY AND WOULD LIKE TO HAVE HIS VEHICLE DIAGNOSED. PLEASE REVIEW FILE FOR CUSTOMER CONCERNS AND UPDATE WITH RESOLUTION. THANKS, FRANK 949 727 6631 CUSTOMER CONCERN WAS SOLVED BY INSTALLING NEW THROTTLE BODY TO CURE STICKY ACCEL PEDAL, RETEST OK 0012003 12 19CRPC569 AT ATTN DCSM/SVM CUST IS CONCERNED THAT HIS ISSUES ARE NOT BEING DEALT WITH UNDER WARRANTY. CUST HAS AN APPOINTMENT WITH YOU NEXT MONDAY AND WOULD LIKE TO HAVE HIS VEHICLE DIAGNOSED. PLEASE REVIEW FILE FOR CUSTOMER CONCERNS AND UPDATE WITH RESOLUTION. THANKS, FRANK 949 727 6631 AS REQUESTED BY CUST ...LETTER SENT TO CUST WITH FILE#
CQIS Recommendations	

Tire Information

Tire Manufacturer	Unknown	Tire Size	Unknown
Tire Brand Series		Wheel	
DOT Left Front		DOT Right Front	
DOT Left Rear		DOT Right Rear	
DOT Left Inner		DOT Right Inner	
DOT Spare			

Vehicle Information

VIN	4F2YU07121K	Engine Serial Number	590718086
Model Year	2001	Engine Description	3.0L DOHC EGI V6 NA*GAS
Transmission	4 SPD AUTO TRANS MAZDA CD4E	Vehicle Description	TRIBUTE
Body Cab Style	CA WE 5 DOOR LIGHT TRUCK	Drive Line	2 WHL L/H FRONT DRIVE
Production Date	21-Sep-2000	Retail Sale Indicator Code	
Plant Description	KANSAS CITY PLANT BUILD	Required Vehicle	
Build Region		Warranty Start Date	01-Feb-2001
Build Country Code		Transmission Serial Number	
Mileage	0	Vehicle Axle Ratio	
Vehicle Restraint Code			

Disclaimer:

This data is for use as one of several potential "awareness" indicators for the Ford Motor Co. Enhanced Concern Identification System. It is unverified, draft, summary data generated from a computer "word search" of customer and technician symptom comments. Supplier data, technician and customer comments are unverified and actual root cause of any potential issue is not established by this summary.

[Contact ODRHELP](#)

Copyright 2001 Ford Motor Co All Rights Reserved

PE12-019

Mazda

9-6-2012

REQUEST NUMBER THREE
DOCUMENTS (SUBJECT)

Consumer Reports

Mazda CAC

ECI

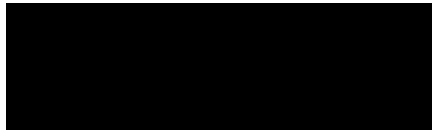



Concern Driven Reporting

Report Detail

Note: Field which are grayed (ghosted) are currently being mapped to the data warehouse. They are not presently being populated.

ECI Record		Source Code	MAZDA CAC
------------	--	-------------	-----------

Commodity Assignment

Commodity	powertrain-engine—	Symptom	no keyword found
Commodity	powertrain-engine-accel pedal/linkage/controls—	Symptom	mod-intermittent/random
Commodity	powertrain-engine-accel pedal/linkage/controls—	Symptom	pedal concerns-accelerator pedal
Commodity	powertrain-engine-accel pedal/linkage/controls—	Symptom	sticks/binds/grabs
Significant Event		Verified	N

Tread Information

Reported in Tread Quarter	Q1 2004
---------------------------	---------

Report Details

Source Claim Key		Warranty Component Classification (WCC)	
Corporate Product Systems Classification (CPS)		Time in Service	21
Customer Condition Code		V Function Group (VFG)	
Source System Program Type		Repair/Report/Paid Date	25-Mar-2004
Version Series Code	AAAA5	Load Date	28-Mar-2004
Causal Part Prefix- Base - Suffix	--	Dealer Code	UNKNOW
Causal Part Name	unknown	Dealer Name	
Non Causal Part Prefix-Base-Suffix		Dealer City	
Non Causal Part Numbers		Dealer State/Province	
Fault Code		Dealer Country	UNK
Diagnostic Trouble Code		Dealer Phone Number	
Labor Operation Code		Attachment	
Communication Type		VOQ Component Description Code	
Maintenance Date	28-Mar-2004		

Customer Comment	CUST SAYS HIS GAS PEDAL STICKS SOMETIMES...
Technician Comment	ADV CUST TO VISIT HIS LOCAL MAZDA DLR FOR DIAGNOSIS AND REPAIR.
CQIS Recommendations	

Tire Information

Tire Manufacturer	Unknown	Tire Size	Unknown
Tire Brand Series		Wheel	
DOT Left Front		DOT Right Front	
DOT Left Rear		DOT Right Rear	
DOT Left Inner		DOT Right Inner	
DOT Spare			

Vehicle Information

VIN	4F2YU081X2R	Engine Serial Number	470126087
Model Year	2002	Engine Description	3.0L DOHC EGI V6 NA*GAS
Transmission	4 SPD AUTO TRANS MAZDA CD4E	Vehicle Description	TRIBUTE
Body Cab Style	CA WE 5 DOOR LIGHT TRUCK	Drive Line	4 WHL L/H PART TIME DRIVE
Production Date	17-Jun-2002	Retail Sale Indicator Code	
Plant Description	KANSAS CITY PLANT BUILD	Required Vehicle	
Build Region		Warranty Start Date	12-Jul-2002
Build Country Code		Transmission Serial Number	
Mileage	0	Vehicle Axle Ratio	
Vehicle Restraint Code			

Disclaimer:

This data is for use as one of several potential "awareness" indicators for the Ford Motor Co. Enhanced Concern Identification System. It is unverified, draft, summary data generated from a computer "word search" of customer and technician symptom comments. Supplier data, technician and customer comments are unverified and actual root cause of any potential issue is not established by this summary.

PE12-019

Mazda

9-6-2012

REQUEST NUMBER THREE
DOCUMENTS (SUBJECT)

Consumer Reports

Mazda CAC

ECI

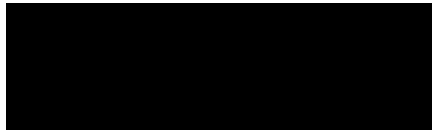



Concern Driven Reporting

Report Detail

Note: Field which are grayed (ghosted) are currently being mapped to the data warehouse. They are not presently being populated.

ECI Record		Source Code	MAZDA CAC
------------	--	-------------	-----------

Commodity Assignment

Commodity	powertrain-engine	Symptom	function-malfunction/inoperative
Commodity	powertrain-engine	Symptom	no keyword found
Commodity	powertrain-engine	Symptom	no problem found
Commodity	powertrain-engine-accel pedal/linkage/controls	Symptom	function-malfunction/inoperative
Commodity	powertrain-engine-accel pedal/linkage/controls	Symptom	mod-driving condition-at cruise
Commodity	powertrain-engine-accel pedal/linkage/controls	Symptom	mod-driving condition-while driving
Commodity	powertrain-engine-accel pedal/linkage/controls	Symptom	pedal concerns-accelerator pedal
Commodity	powertrain-engine-accel pedal/linkage/controls	Symptom	sticks/binds/grabs
Commodity	powertrain-engine-air induction-throttle body-	Symptom	function-malfunction/inoperative
Commodity	powertrain-engine-air induction-throttle body-	Symptom	mod-driving condition-at cruise
Commodity	powertrain-engine-air induction-throttle body-	Symptom	mod-driving condition-while driving
Commodity	powertrain-engine-air induction-throttle body-	Symptom	sticks/binds/grabs
Significant Event		Verified	N

Tread Information

Reported in Tread Quarter	Q1 2004 Q2 2004
---------------------------	-----------------

Report Details

Source Claim Key		Warranty Component Classification (WCC)	
Corporate Product Systems Classification (CPSC)		Time in Service	14
Customer Condition Code		V Function Group (VFG)	
Source System Program Type		Repair/Report/Paid Date	30-Jan-2004
Version Series Code	AAAQK	Load Date	13-Apr-2004
Causal Part Prefix-Base-Suffix	-	Dealer Code	51512
Causal Part Name	unknown	Dealer Name	FAIRHAVEN MAZDA
Non Causal Part Prefix-Base-Suffix		Dealer City	FAIRHAVEN
Non Causal Part Numbers		Dealer State/Province	MA
Fault Code		Dealer Country	USA
Diagnostic Trouble Code		Dealer Phone Number	
Labor Operation Code		Attachment	
Communication Type		VOQ Component Description Code	
Maintenance Date	13-Apr-2004		

Customer Comment	CST STS HE HAS BEEN ADDRESSING THIS CONCERN THROTTLE STICKING SINCE HE BOUGHT VEH AND HAVE BEEN ABLE TO DUPLICATE. CST STS NOW THEY WANT TO CHARGE THROTTLE BODY SERVICE WHICH HE DOES NO FEEL HE SHOULD HAVE TO PAY. CST STS HE IS ALSO HAVING TRANS PROB W/ O/D NOT SHIFTING INTO GEAR ON HWY. CST STS HE DOES NOT BELIEVE ITS NORMAL.
Technician Comment	0032004 04 05CRPC174 RECEIVED EMAIL FROM DAN AND KARSTEN ABOUT FILE WITH AN UPDATE FROM SVM CLIFF ABOUT THE RESOLUTION. CLLD SVM CLIFF LEFT VM TO PLS CLOSE FILE W/FINAL RESOLUTION. 0022004 01 30CRPC174 CST. 0012004 01 30CRPC174 AT PLEASE REVIEW FILE AND CLOSE W/RESOLUTION. THX, JERRY S (949) 727 6249 INFORMED CST I DO APOLOGIZE AND WILL CALL DLR SVM TO SEE IF WE CAN COVER THIS THROTTLE SERVICE THIS ONE TIME BUT IT IS NORMALLY MAINT ITEM. INFORMED CST I WILL ALSO MAKE SURE THEY ADDRESS HIS SHIFTING CONCERN ON HWYS. CST STS OK CLLD DLR SPK W/ANDY ASSIST AND ADDRESSED CST CONCERN. INFORMED ANDY TO COVER THE THROTTLE SERVICE IF NEED BE BUT YOUR DLR IS GOLD DSA DLR SO I DONT SEE A PROB AND TEST DRIVE VEH W/ THROTTLE PLATE STICKING CLEANEDTHROTTLE BODY .PEFORMED FUEL SERVICE CUST HAS NO HISTORY FOR TRANSMISSION CONCERN CUST STATES WILL HAVE CHECKED AT NEXT SERVICE DUE POSS MAY. PLEASE REVIEW FILE AND CLOSE W/RESOLUTION. THX, JERRY S (949) 727 6249
CQIS Recommendations	

Tire Information

Tire Manufacturer	Unknown	Tire Size	Unknown
Tire Brand Series		Wheel	
DOT Left Front		DOT Right Front	
DOT Left Rear		DOT Right Rear	
DOT Left Inner		DOT Right Inner	
DOT Spare			

Vehicle Information

VIN	4F2CZ96103K	Engine Serial Number	
Model Year	2003	Engine Description	3.0L DOHC EGI V6 NA*G DSP2967
Transmission	4 SPD AUTO TRANS MAZDA CD4E	Vehicle Description	TRIBUTE
Body Cab Style	CA WE 5 DOOR LIGHT TRUCK	Drive Line	4 WHL L/H PART TIME DRIVE
Production Date	19-Sep-2002	Retail Sale Indicator Code	
Plant Description	KANSAS CITY PLANT BUILD	Required Vehicle	
Build Region		Warranty Start Date	30-Dec-2002
Build Country Code		Transmission Serial Number	
Mileage	18000	Vehicle Axle Ratio	

Disclaimer:

This data is for use as one of several potential "awareness" indicators for the Ford Motor Co. Enhanced Concern Identification System. It is unverified, draft, summary data generated from a computer "word search" of customer and technician symptom comments. Supplier data, technician and customer comments are unverified and actual root cause of any potential issue is not established by this summary.

[Contact CDR HELP](#)

Copyright 2001 Ford Motor Co All Rights Reserved

PE12-019

Mazda

9-6-2012

REQUEST NUMBER THREE
DOCUMENTS (SUBJECT)

Consumer Reports

Mazda CAC

ECI

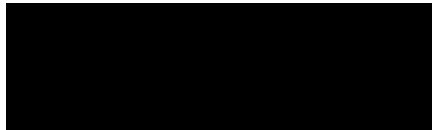



Concern Driven Reporting

Report Detail

Note: Field which are grayed (ghosted) are currently being mapped to the data warehouse. They are not presently being populated.

ECI Record		Source Code	MAZDA CAC
------------	--	-------------	-----------

Commodity Assignment

Commodity	powertrain-engine	Symptom	function-malfunction/inoperative
Commodity	powertrain-engine-accel pedal/linkage/controls	Symptom	engine rpm surge/flare
Commodity	powertrain-engine-accel pedal/linkage/controls	Symptom	loss of control
Commodity	powertrain-engine-accel pedal/linkage/controls	Symptom	mod-driving condition-at high rpm
Commodity	powertrain-engine-accel pedal/linkage/controls	Symptom	mod-driving condition-on acceleration
Commodity	powertrain-engine-accel pedal/linkage/controls	Symptom	mod-driving condition-while driving
Commodity	powertrain-engine-accel pedal/linkage/controls	Symptom	pedal concerns-accelerator pedal
Significant Event		Verified	N

Tread Information

Reported in Tread Quarter	Q1 2004 Q2 2004
---------------------------	-----------------

Report Details

Source Claim Key		Warranty Component Classification (WCC)	
Corporate Product Systems Classification (CPSC)		Time in Service	24
Customer Condition Code		V Function Group (VFG)	
Source System Program Type		Repair/Report/Paid Date	29-Mar-2004
Version Series Code	AAAA5	Load Date	13-Apr-2004
Causal Part Prefix- Base - Suffix	-	Dealer Code	61521
Causal Part Name	unknown	Dealer Name	SUBURBAN MAZDA OF TROY
Non Causal Part Prefix-Base-Suffix		Dealer City	TROY
Non Causal Part Numbers		Dealer State/Province	MI
Fault Code		Dealer Country	USA
Diagnostic Trouble Code		Dealer Phone Number	2486492300
Labor Operation Code		Attachment	
Communication Type		VOQ Component Description Code	
Maintenance Date	13-Apr-2004		

Customer Comment CUST STATES THAT THE VEHICLE REVS TO 6000 RPM WITHOUT STEPPING ON THE GAS PEDAL. CUST IS CONCERNED THAT THE VEHICLE WILL ACCELERATE OUT OF CONTROL IF SHE STEPS OFF THE BRAKE...

Technician Comment 0012004 03 29CRPC569 AT ATTN DCSM/SVM PLEASE REVIEW FILE FOR CUSTOMER CONCERNS... THE CUST WILL BE VISITING THE DLR TO HAVE THE VEHICLE LOOKED AT...SHE ATTEMPTED TO HAVE IT REPAIRED AT ANOTHER MECHANIC BUT THE VEHICLE IS STILL HAVING THE SAME PROBLEM. ADV CUST TO TAKE IT TO AN AUTHORIZED MAZDA DLR TO HAVE REPAIRS DONE. PLEASE UPDATE FILE WITH RESOLUTION AND CLOSE. 0000 NO MRS. JENNINGS CALLED ME, EXPLAINED THE PROBLEM. AND TOLD ME THAT SHE WAS GOING BACK TO THE PEOPLE WHO RATTENDED TO FIX THE FIRST TIME. IF WE FOUND NO SATISFACTION SHE WOULD CALL ME FOR AN APPT TIME AND DAY. SHE HAS MY DIRECT LINE AND I HAVEN'T HEARD FROM HER YET. ATTN DCSM/SVM PLEASE REVIEW FILE FOR CUSTOMER CONCERNS... THE CUST WILL BE VISITING THE DLR TO HAVE THE VEHICLE LOOKED AT...SHE ATTEMPTED TO HAVE IT REPAIRED AT ANOTHER MECHANIC BUT THE VEHICLE IS STILL HAVING THE SAME PROBLEM. ADV CUST TO TAKE IT TO AN AUTHORIZED MAZDA DLR TO HAVE REPAIRS DONE. PLEASE UPDATE FILE WITH RESOLUTION AND CLOSE.

CQIS Recommendations

Tire Information

Tire Manufacturer	Unknown	Tire Size	Unknown
Tire Brand Series		Wheel	
DOT Left Front		DOT Right Front	
DOT Left Rear		DOT Right Rear	
DOT Left Inner		DOT Right Inner	
DOT Spare			

Vehicle Information

VIN	4F2CU08182K	Engine Serial Number	148592087
Model Year	2002	Engine Description	3.0L DOHC EGI V6 NA*GAS
Transmission	4 SPD AUTO TRANS MAZDA CD4E	Vehicle Description	TRIBUTE
Body Cab Style	CA WE 5 DOOR LIGHT TRUCK	Drive Line	4 WHL L/H PART TIME DRIVE
Production Date	05-Nov-2001	Retail Sale Indicator Code	
Plant Description	KANSAS CITY PLANT BUILD	Required Vehicle	
Build Region		Warranty Start Date	29-Apr-2002
Build Country Code		Transmission Serial Number	
Mileage	0	Vehicle Axle Ratio	
Vehicle Restraint Code			

Disclaimer:

This data is for use as one of several potential "awareness" indicators for the Ford Motor Co. Enhanced Concern Identification System. It is unverified, draft, summary data generated from a computer "word search" of customer and technician symptom comments. Supplier data, technician and customer comments are unverified and actual root cause of any potential issue is not established by this summary.

[Contact ODRHELP](#)

Copyright 2001 Ford Motor Co All Rights Reserved

PE12-019

Mazda

9-6-2012

REQUEST NUMBER THREE
DOCUMENTS (SUBJECT)

Consumer Reports

Mazda CAC

ECI

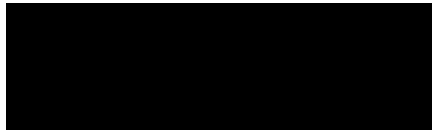



Concern Driven Reporting

Report Detail

Note: Field which are grayed (ghosted) are currently being mapped to the data warehouse. They are not presently being populated.

ECI Record		Source Code	MAZDA CAC
------------	--	-------------	-----------

Commodity Assignment

Commodity	powertrain-engine—	Symptom	no keyword found
Commodity	powertrain-engine-accel pedal/linkage/controls—	Symptom	sticks/binds/grabs
Commodity	powertrain-engine-air induction-throttle body-	Symptom	sticks/binds/grabs
Significant Event		Verified	N

Tread Information

Reported in Tread Quarter	Q2 2004
---------------------------	---------

Report Details

Source Claim Key		Warranty Component Classification (WCC)	
Corporate Product Systems Classification (CPSC)		Time in Service	15
Customer Condition Code		V Function Group (VFG)	
Source System Program Type		Repair/Report/Paid Date	02-Jun-2004
Version Series Code	AAAA5	Load Date	08-Jun-2004
Causal Part Prefix- Base - Suffix	- -	Dealer Code	23203
Causal Part Name	unknown	Dealer Name	SKYLAND MAZDA
Non Causal Part Prefix-Base-Suffix		Dealer City	ASHEVILLE
Non Causal Part Numbers		Dealer State/Province	NC
Fault Code		Dealer Country	USA
Diagonstic Trouble Code		Dealer Phone Number	8286675213
Labor Operation Code		Attachment	
Communication Type		VOQ Component Description Code	
Maintenance Date	08-Jun-2004		

Customer Comment	RCV'D C/A VM FROM KEN BROKAW, SVC MGR. STS CUST SAID CONTACTED MNAO FOR GDWL FOR FUEL PEDDLE STICKING. FOUND CARBON BUILD ON THROTTLE BODY. STS IS MAINT ITEM. STS HAS 1 SVC MAINT ON JUNE 2003 FOR OIL. NO OTHER SVC. WILL NOT PROVIDING ANY GDWL FOR VEH.		
Technician Comment	DOC'D COMMENTS PER SVM.		
CQIS Recommendations			

Tire Information

Tire Manufacturer	Unknown	Tire Size	Unknown
Tire Brand Series		Wheel	
DOT Left Front		DOT Right Front	
DOT Left Rear		DOT Right Rear	
DOT Left Inner		DOT Right Inner	
DOT Spare			

Vehicle Information

VIN	4F2YZ94183K	Engine Serial Number	
Model Year	2003	Engine Description	3.0L DOHC EGI V6 NA*G DSP2967
Transmission	4 SPD AUTO TRANS MAZDA CD4E	Vehicle Description	TRIBUTE
Body Cab Style	CA WE 5 DOOR LIGHT TRUCK	Drive Line	4 WHL L/H PART TIME DRIVE
Production Date	30-Oct-2002	Retail Sale Indicator Code	
Plant Description	KANSAS CITY PLANT BUILD	Required Vehicle	
Build Region		Warranty Start Date	01-Apr-2003
Build Country Code		Transmission Serial Number	
Mileage	27890	Vehicle Axle Ratio	
Vehicle Restraint Code			

Disclaimer:

This data is for use as one of several potential "awareness" indicators for the Ford Motor Co. Enhanced Concern Identification System. It is unverified, draft, summary data generated from a computer "word search" of customer and technician symptom comments. Supplier data, technician and customer comments are unverified and actual root cause of any potential issue is not established by this summary.

[Contact ODRHELP](#)

Copyright 2001 Ford Motor Co All Rights Reserved

PE12-019

Mazda

9-6-2012

REQUEST NUMBER THREE
DOCUMENTS (SUBJECT)

Consumer Reports

Mazda CAC

ECI

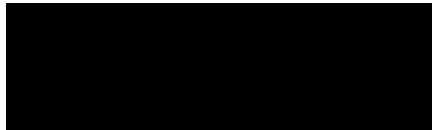



Concern Driven Reporting

Report Detail

Note: Field which are grayed (ghosted) are currently being mapped to the data warehouse. They are not presently being populated.

ECI Record		Source Code	MAZDA CAC
------------	--	-------------	-----------

Commodity Assignment			
Commodity	powertrain-engine	Symptom	administrative cost
Commodity	powertrain-engine	Symptom	damage
Commodity	powertrain-engine	Symptom	mod-vehicle towed in
Commodity	powertrain-engine-accel pedal/linkage/controls	Symptom	function-malfunction/inoperative
Commodity	powertrain-engine-accel pedal/linkage/controls	Symptom	pedal concerns-accelerator pedal
Commodity	powertrain-engine-accel pedal/linkage/controls	Symptom	sticks/binds/grabs
Significant Event		Verified	N

Tread Information	
Reported in Tread Quarter	Q3 2004

Report Details			
Source Claim Key		Warranty Component Classification (WCC)	
Corporate Product Systems Classification (CPSC)		Time in Service	17
Customer Condition Code		V Function Group (VFG)	
Source System Program Type		Repair/Report/Paid Date	02-Aug-2004
Version Series Code	AAAA5	Load Date	08-Aug-2004
Causal Part Prefix-Base-Suffix	-	Dealer Code	UNKNOW
Causal Part Name	unknown	Dealer Name	
Non Causal Part Prefix-Base-Suffix		Dealer City	
Non Causal Part Numbers		Dealer State/Province	
Fault Code		Dealer Country	UNK
Diagonstic Trouble Code		Dealer Phone Number	
Labor Operation Code		Attachment	
Communication Type		VOQ Component Description Code	
Maintenance Date	08-Aug-2004		

Customer Comment	CST ADV THAT SHE WAS BROKEN DOWN ON THE SIDE OF THE ROAD AND THEN GAS PEDAL WAS STUCK. ADV SHE NEEDED SOME HELP		
Technician Comment	ADV CST THE PHONE NUMBER FOR ROAD SIDE ASSISTANCE AND ADV CST THAT THEY WILL TOW VEH TO CLOSEST MAZDA DLR FOR VEH TO BE REPAIRED. ADV THAT IF VEH DAMAGE IS COVERED UNDER WTTY A RENTAL VEH WILL BE PROVIDED. CST THANKED.		
CQIS Recommendations			

Tire Information			
Tire Manufacturer	Unknown	Tire Size	Unknown
Tire Brand Series		Wheel	
DOT Left Front		DOT Right Front	
DOT Left Rear		DOT Right Rear	
DOT Left Inner		DOT Right Inner	
DOT Spare			

Vehicle Information			
VIN	4F2YZ94123K	Engine Serial Number	
Model Year	2003	Engine Description	3.0L DOHC EGI V6 NA*G DSP2967
Transmission	4 SPD AUTO TRANS MAZDA CD4E	Vehicle Description	TRIBUTE
Body Cab Style	CA WE 5 DOOR LIGHT TRUCK	Drive Line	4 WHL L/H PART TIME DRIVE
Production Date	25-Nov-2002	Retail Sale Indicator Code	
Plant Description	KANSAS CITY PLANT BUILD	Reaquired Vehicle	
Build Region		Warranty Start Date	26-Mar-2003
Build Country Code		Transmission Serial Number	
Mileage	30000	Vehicle Axle Ratio	
Vehicle Restraint Code			

Disclaimer:

This data is for use as one of several potential "awareness" indicators for the Ford Motor Co. Enhanced Concern Identification System. It is unverified, draft, summary data generated from a computer "word search" of customer and technician symptom comments. Supplier data, technician and customer comments are unverified and actual root cause of any potential issue is not established by this summary.

[Contact ODRHELP](#)

Copyright 2001 Ford Motor Co All Rights Reserved

PE12-019

Mazda

9-6-2012

REQUEST NUMBER THREE
DOCUMENTS (SUBJECT)

Consumer Reports

Mazda CAC

ECI

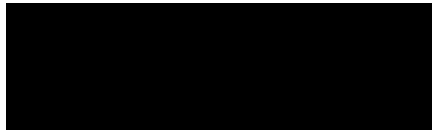



Concern Driven Reporting

Report Detail

Note: Field which are grayed (ghosted) are currently being mapped to the data warehouse. They are not presently being populated.

ECI Record		Source Code	MAZDA CAC
------------	--	-------------	-----------

Commodity Assignment			
Commodity	powertrain-engine—	Symptom	no keyword found
Commodity	powertrain-engine-accel pedal/linkage/controls—	Symptom	mod-driving condition-on acceleration
Commodity	powertrain-engine-accel pedal/linkage/controls—	Symptom	mod-driving condition-while driving
Commodity	powertrain-engine-accel pedal/linkage/controls—	Symptom	pedal concerns-accelerator pedal
Commodity	powertrain-engine-accel pedal/linkage/controls—	Symptom	pedal concerns-pedal positions
Commodity	powertrain-engine-accel pedal/linkage/controls—	Symptom	sticks/binds/grabs
Significant Event		Verified	N

Tread Information	
Reported in Tread Quarter	Q4 2004

Report Details			
Source Claim Key		Warranty Component Classification (WCC)	
Corporate Product Systems Classification (CPSC)		Time in Service	17
Customer Condition Code		V Function Group (VFG)	
Source System Program Type		Repair/Report/Paid Date	22-Oct-2004
Version Series Code	AAAA5	Load Date	24-Oct-2004
Causal Part Prefix- Base - Suffix	- -	Dealer Code	UNKNOW
Causal Part Name	unknown	Dealer Name	
Non Causal Part Prefix-Base-Suffix		Dealer City	
Non Causal Part Numbers		Dealer State/Province	
Fault Code		Dealer Country	UNK
Diagonstic Trouble Code		Dealer Phone Number	
Labor Operation Code		Attachment	
Communication Type		VOQ Component Description Code	
Maintenance Date	24-Oct-2004		

Customer Comment	STS WIFE WAS RECENTLY DRIVNING VEH AND VEH'S GAS PEDAL GOT STUCK IN ACCELERATION POSITION, NO ONE HURT. STS DLR DIAG VEH AS HAVING STCIKY CABLES AND VEH IS FINE NOW. STS IS NERVOUS ABOUT HAVING WIFE DRIVE VEH.		
Technician Comment	0012004 10 22CRPC427 REQ DESC VEHICLE COMPLIANT THANKED CST FOR COMMENTS AND ADVD CST THAT PRODUCT PLANNING AND ENGINEERING DEPTS REVIEW CST'S COMMENTS REGARDING VEHS. ALSO ADVD CST TO CONTACT NHTSA. SUP (MICHELE) APPROVED LTR.		
CQIS Recommendations			

Tire Information			
Tire Manufacturer	Unknown	Tire Size	Unknown
Tire Brand Series		Wheel	
DOT Left Front		DOT Right Front	
DOT Left Rear		DOT Right Rear	
DOT Left Inner		DOT Right Inner	
DOT Spare			

Vehicle Information			
VIN	4F2YZ94183K	Engine Serial Number	
Model Year	2003	Engine Description	3.0L DOHC EGI V6 NA*G DSP2967
Transmission	4 SPD AUTO TRANS MAZDA CD4E	Vehicle Description	TRIBUTE
Body Cab Style	CA WE 5 DOOR LIGHT TRUCK	Drive Line	4 WHL L/H PART TIME DRIVE
Production Date	13-Feb-2003	Retail Sale Indicator Code	
Plant Description	KANSAS CITY PLANT BUILD	Reaquired Vehicle	
Build Region		Warranty Start Date	05-Jun-2003
Build Country Code		Transmission Serial Number	
Mileage	0	Vehicle Axle Ratio	
Vehicle Restraint Code			

Disclaimer:

This data is for use as one of several potential "awareness" indicators for the Ford Motor Co. Enhanced Concern Identification System. It is unverified, draft, summary data generated from a computer "word search" of customer and technician symptom comments. Supplier data, technician and customer comments are unverified and actual root cause of any potential issue is not established by this summary.

[Contact ODRHELP](#)

Copyright 2001 Ford Motor Co All Rights Reserved

PE12-019

Mazda

9-6-2012

REQUEST NUMBER THREE
DOCUMENTS (SUBJECT)

Consumer Reports

Mazda CAC

ECI 



Concern Driven Reporting

Report Detail

Note: Field which are grayed (ghosted) are currently being mapped to the data warehouse. They are not presently being populated.

ECI Record		Source Code	MAZDA CAC
------------	--	-------------	-----------

Commodity Assignment

Commodity	Symptom	function-lack of engagement
powertrain-engine	Symptom	function-malfunction/inoperative
powertrain-engine	Symptom	no keyword found
powertrain-engine	Symptom	pedal concerns-accelerator pedal
powertrain-engine	Symptom	repair-prior repair mentioned
powertrain-engine	Symptom	unintended acceleration
powertrain-engine-accel pedal/linkage/controls	Symptom	function-malfunction/inoperative
powertrain-engine-accel pedal/linkage/controls	Symptom	high effort
powertrain-engine-accel pedal/linkage/controls	Symptom	pedal concerns-accelerator pedal
powertrain-engine-accel pedal/linkage/controls	Symptom	repair-prior repair mentioned
powertrain-engine-accel pedal/linkage/controls	Symptom	sticks/binds/grabs
powertrain-engine-air induction-throttle body-	Symptom	function-malfunction/inoperative
powertrain-engine-air induction-throttle body-	Symptom	repair-prior repair mentioned
powertrain-engine-air induction-throttle body-	Symptom	sticks/binds/grabs
Significant Event	Verified	N

Tread Information

Reported in Tread Quarter	Q4 2004
---------------------------	---------

Report Details

Source Claim Key		Warranty Component Classification (WCC)	
Corporate Product Systems Classification (CPSC)		Time in Service	26
Customer Condition Code		V Function Group (VFG)	
Source System Program Type		Repair/Report/Paid Date	11-Oct-2004
Version Series Code	AAAQK	Load Date	07-Nov-2004
Causal Part Prefix-Base-Suffix	--	Dealer Code	51401
Causal Part Name	NOT PROVIDED BY SOURCE	Dealer Name	RAINES MAZDA
Non Causal Part Prefix-Base-Suffix		Dealer City	SOUTH CHARLESTON
Non Causal Part Numbers		Dealer State/Province	WV
Fault Code		Dealer Country	USA
Diagnosis Trouble Code		Dealer Phone Number	
Labor Operation Code		Attachment	
Communication Type		VOQ Component Description Code	
Maintenance Date	21-Aug-2005		

Customer Comment CUST STS THAT WHEN HE APPLIES PRESSURE TO THE ACCELERATOR THE VEH WONT MOVE. WHEN HE APPLIES A LITTLW BIT MORE THE VEH WILL LUNGE FORWARD. CST STS THAT DLR HAS ALREADY REPLACED THE THROTTLE, WHICH HELPED BUT DIDNT RESOLVE. CUST STS THAT DLR STS THAT THEY DOENT KNOW WHAT THE PROBLEM IS.

Technician Comment 0052005 08 16CRPC666 REPLACED THROTTLE BODY FOR STICKY SPOT AND REPLACED THROTTLE CABLE FOR HARD SPOT IN IT. REPLACED THROTTLE BODY FOR STICKY SPOT AND REPLACED THROTTLE CABLE FOR HARD SPOT IN IT. 0042005 07 13CRPC666 RD THIS FILE TO DCSM TO LOOK AT. ADV DUST TO SCHEDULE APPT WITH SVM IN ORDER TO SPEAK WITH THE DCSM. CASE REOPEN DUE TO NO SOLUTION. 0032005 07 13CRPC666 AT ATTN SVM/DCSM CUST HAS MANY DOCUMENTATION OF THE SAME PROBLEM. AT THIS POINT DLR HAVE TOLD CUST THAT THERE IS NOTHING ELSE THEY COULD DO TO IMPROVE THE SITUATION. REPLACED THROTTLE BODY ONCE. PROBLEM STILL REMAINS. PLEASE KINDLY REVIEW THE FILE AND CLOSE UPON RESOLUTION. THANK YOU. HANS 949 727 6888. 0000 N0CUST CALLED FOR THE SAME PROBLEM. DLR TOLD CUST THAT THERE IS NOTHING ELSE THEY COULD DO TO MEET CUST'S SATISFACTION. ADV DUST THAT HIS HAS BEEN AN ONGOING PROBLEM AND WOULD FORWA 0022004 12 27CRPC646 CUST STS THAT IS STILL SAME PROBLEMS WITH VEH. AVSD CUST THAT NEEDS TO TAKE VEH TO DLR TO HAVE DIAG. ADV THAT VEH IS STILL UNDER WTTY. 0012004 10 11CRPC609 AT ATTN DCSM/SVM PLEASE REVIEW FILE FOR ANY POSSIBLE ASSISTANCE. PLEASE CONTACT TECH HOTLINE FOR ANY ADDITIONAL ASSISTANCE. PLEASE CONTACT CUSTOMER, ADD NOTES, AND CLOSE. THANKS CHRIS MNAO (949) 727 6303 REQ DESC THROTTLE PROBLEM REPLACED THROTTLE BODY FOR STICKY SPOT AND REPLACED THROTTLE CABLE FOR HARD SPOT IN IT. REPLACED THROTTLE BODY FOR STICKY SPOT AND REPLACED THROTTLE CABLE FOR HARD SPOT IN IT. REPLACED THROTTLE BODY FOR STICKY SPOT AND REPLACED THROTTLE CABLE FOR HARD SPOT IN IT. ATTN DCSM/SVM PLEASE REVIEW FILE FOR ANY POSSIBLE ASSISTANCE. PLEASE CONTACT TECH HOTLINE FOR ANY ADDITIONAL ASSISTANCE. PLEASE CONTACT CUSTOMER, ADD NOTES, AND CLOSE. THANKS CHRIS MNAO (949) 727 6303

CQIS Recommendations	
----------------------	--

Tire Information

Tire Manufacturer	Unknown	Tire Size	Unknown
Tire Brand Series		Wheel	
DOT Left Front		DOT Right Front	
DOT Left Rear		DOT Right Rear	
DOT Left Inner		DOT Right Inner	
DOT Spare			

Vehicle Information

VIN	4F2CU08152K	Engine Serial Number	472601087
Model Year	2002	Engine Description	3.0L DOHC EGI V6 NA*GAS
Transmission	4 SPD AUTO TRANS MAZDA CD4E	Vehicle Description	TRIBUTE
Body Cab Style	CA WE 3 DOOR LIGHT TRUCK	Drive Line	4 WHL L/H PART TIME DRIVE
Production Date	18-Jun-2002	Retail Sale Indicator Code	
Plant Description	KANSAS CITY PLANT BUILD	Required Vehicle	
Build Region		Warranty Start Date	31-Aug-2002
Build Country Code		Transmission Serial Number	
Mileage	32000	Vehicle Axle Ratio	
Vehicle Restraint Code			

Disclaimer:

This data is for use as one of several potential "awareness" indicators for the Ford Motor Co. Enhanced Concern Identification System. It is unverified, draft, summary data generated from a computer "word search" of customer and technician symptom comments. Supplier data, technician and customer comments are unverified and actual root cause of any potential issue is not established by this summary.

[Contact CDR HELP](#)

Copyright 2001 Ford Motor Co All Rights Reserved

PE12-019

Mazda

9-6-2012

REQUEST NUMBER THREE
DOCUMENTS (SUBJECT)

Consumer Reports

Mazda CAC

ECI

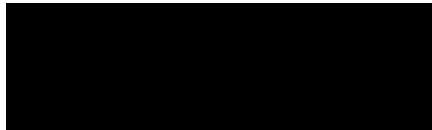



Concern Driven Reporting

Report Detail

Note: Field which are grayed (ghosted) are currently being mapped to the data warehouse. They are not presently being populated.

ECI Record		Source Code	MAZDA CAC
------------	--	-------------	-----------

Commodity Assignment			
Commodity	powertrain-engine	Symptom	function-malfunction/inoperative
Commodity	powertrain-engine	Symptom	no keyword found
Commodity	powertrain-engine	Symptom	part-missing part
Commodity	powertrain-engine	Symptom	repair-prior repair mentioned
Commodity	powertrain-engine-accel pedal/linkage/controls	Symptom	function-malfunction/inoperative
Commodity	powertrain-engine-accel pedal/linkage/controls	Symptom	pedal concerns-accelerator pedal
Commodity	powertrain-engine-accel pedal/linkage/controls	Symptom	sticks/binds/grabs
Significant Event		Verified	N

Tread Information	
Reported in Tread Quarter	Q4 2004

Report Details			
Source Claim Key		Warranty Component Classification (WCC)	
Corporate Product Systems Classification (CPSC)		Time in Service	17
Customer Condition Code		V Function Group (VFG)	
Source System Program Type		Repair/Report/Paid Date	12-Nov-2004
Version Series Code	AAAA5	Load Date	21-Nov-2004
Causal Part Prefix- Base - Suffix	-	Dealer Code	51434
Causal Part Name	unknown	Dealer Name	HERITAGE MAZDA
Non Causal Part Prefix-Base-Suffix		Dealer City	OWINGS MILLS
Non Causal Part Numbers		Dealer State/Province	MD
Fault Code		Dealer Country	USA
Diagnostic Trouble Code		Dealer Phone Number	
Labor Operation Code		Attachment	
Communication Type		VOQ Component Description Code	
Maintenance Date	21-Nov-2004		

Customer Comment	CUST COMPLAINT ABOUT CARBON BUILD UP. CUST STS THAT SHE HAS HAD PREVIOUS PROBLEMS WITH GAS PEDAL STICKING. CUST STS THAT DLR ADV HER OF CARBON BUILD UP. CUST STS DLR ADV HER TO SWITCH GAS. DLR ALSO ADV CUST PROBLEM WILL COME BACK. CUST WANTS PROBLEM RESOLVED. STS THAT DLR ALREADY CLEANED CARBON BUILD UP		
Technician Comment	ATTN DLR/DSCM PLEASE ADD CLOSING NOTES TO CUST FILETHANKSSAM949 727 6582 CALLED CUSTOMER AND TOLD HER WE HAD GOTTEN INFO ON A PART THAT WILL RESOLVE THE CONCERN SHE IS HAVEING WITH HER VAN. I HAVE ORDERED THE PART AND SHE WILL BRING THE VAN THIS WEEK FOR THE REPAIR. 11 12CRPC607 AT ATTN DLR/DSCM PLEASE ADD CLOSING NOTES TO CUST FILETHANKSSAM949 727 6582 REQ DESC CARBON BUILD UP ADV CUST THAT CARBON BUILD UP IS MAINT ITEM AND CUST PAY. ADV CUST TO FOLLOW DLR SUGGESTION AND SWITCH GAS. ADV CUST IF PROBLEM COMES BACK TO CALL BACK CAC AND INQ IF THERE IS ANYTHING CR CAN DO TO ASSIST. ADV CUST IF SHE IS NOT SATISFIED WITH DLR SVC TO TAKE VEH TO OTHER DLR AND SEEK 2ND OPINION		
CQIS Recommendations			

Tire Information			
Tire Manufacturer	Unknown	Tire Size	Unknown
Tire Brand Series		Wheel	
DOT Left Front		DOT Right Front	
DOT Left Rear		DOT Right Rear	
DOT Left Inner		DOT Right Inner	
DOT Spare			

Vehicle Information			
VIN	4F2CZ94173K	Engine Serial Number	
Model Year	2003	Engine Description	3.0L DOHC EGI V6 NA *G DSP2967
Transmission	4 SPD AUTO TRANS MAZDA CD4E	Vehicle Description	TRIBUTE
Body Cab Style	CA WE 5 DOOR LIGHT TRUCK	Drive Line	4 WHL L/H PART TIME DRIVE
Production Date	10-Oct-2002	Retail Sale Indicator Code	
Plant Description	KANSAS CITY PLANT BUILD	Required Vehicle	
Build Region		Warranty Start Date	05-Jul-2003
Build Country Code		Transmission Serial Number	
Mileage	21000	Vehicle Axle Ratio	
Vehicle Restraint Code			

Disclaimer:

This data is for use as one of several potential "awareness" indicators for the Ford Motor Co. Enhanced Concern Identification System. It is unverified, draft, summary data generated from a computer "word search" of customer and technician symptom comments. Supplier data, technician and customer comments are unverified and actual root cause of any potential issue is not established by this summary.

[Contact ODRHELP](#)

Copyright 2001 Ford Motor Co All Rights Reserved

PE12-019

Mazda

9-6-2012

REQUEST NUMBER THREE
DOCUMENTS (SUBJECT)

Consumer Reports

Mazda CAC

ECI

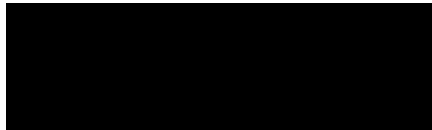



Concern Driven Reporting

Report Detail

Note: Field which are grayed (ghosted) are currently being mapped to the data warehouse. They are not presently being populated.

ECI Record		Source Code	MAZDA CAC
------------	--	-------------	-----------

Commodity Assignment			
Commodity	powertrain-engine	Symptom	no keyword found
Commodity	powertrain-engine-accel pedal/linkage/controls	Symptom	pedal concerns-accelerator pedal
Commodity	powertrain-engine-accel pedal/linkage/controls	Symptom	sticks/binds/grabs
Significant Event		Verified	N

Tread Information	
Reported in Tread Quarter	Q4 2004

Report Details			
Source Claim Key		Warranty Component Classification (WCC)	
Corporate Product Systems Classification (CPSC)		Time in Service	28
Customer Condition Code		V Function Group (VFG)	
Source System Program Type		Repair/Report/Paid Date	16-Nov-2004
Version Series Code	AAAQK	Load Date	21-Nov-2004
Causal Part Prefix- Base - Suffix	- -	Dealer Code	34486
Causal Part Name	unknown	Dealer Name	INGRAM PARK MAZDA
Non Causal Part Prefix-Base-Suffix		Dealer City	SAN ANTONIO
Non Causal Part Numbers		Dealer State/Province	TX
Fault Code		Dealer Country	USA
Diagonstic Trouble Code		Dealer Phone Number	2104060122
Labor Operation Code		Attachment	
Communication Iype		VOQ Component Description Code	
Maintenance Date	21-Nov-2004		

Customer Comment	CUST STS THAT HER GAS PEDAL WAS STICKING. STS THAT DLR ADV HER SHE NEEDS CARBON CLEAN UP. CUST STS THAT IT IS NOT MENTIONED ANYWHERE IN THE OWNERS MANUAL		
Technician Comment	0012004 11 16CRPC607 AT ATTN DLR PLEASE ADD CLOSING NOTES TO CUST FILETHANKSSAM949 727 6582 REQ DESC CARBON CLEAN UP CALLED DLR AND TT MARK IN SVC. STS THAT CARBONBUILD UP IS MAINT AND CUST JUST NEEDS THE CARBON CLEANED UP CALLED BACK CUST AND ADV CUST THAT CARBON BUILD UP IS MAINT BUT MAZDA WILL GOODWILL CLEAN UP FOR CUST. APOLOGIZED FOR INCONVEIENCE FOR CUST. ADV CUST WILL SEND GC DEALER DID NOT OFFER ASSISTANCE SINCE VEHICLE NEEDED JUST ROUTINE MAINT.CUST HAS DONE NO MAINT WITH DEALER. CUST SAYS MAZDA SENDING THEM GIFT CERTIFICATE. ATTN DLR PLEASE ADD CLOSING NOTES TO CUST FILETHANKSSAM949 727 6582		
CQIS Recommendations			

Tire Information			
Tire Manufacturer	Unknown	Tire Size	Unknown
Tire Brand Series		Wheel	
DOT Left Front		DOT Right Front	
DOT Left Rear		DOT Right Rear	
DOT Left Inner		DOT Right Inner	
DOT Spare			

Vehicle Information			
VIN	4F2CU09192K	Engine Serial Number	339178087
Model Year	2002	Engine Description	3.0L DOHC EGI V6 NA*GAS
Transmission	4 SPD AUTO TRANS MAZDA CD4E	Vehicle Description	TRIBUTE
Body Cab Style	CA WE 5 DOOR LIGHT TRUCK	Drive Line	2 WHL L/H FRONT DRIVE
Production Date	21-Mar-2002	Retail Sale Indicator Code	
Plant Description	KANSAS CITY PLANT BUILD	Required Vehicle	
Build Region		Warranty Start Date	19-Aug-2002
Build Country Code		Transmission Serial Number	
Mileage	35000	Vehicle Axle Ratio	
Vehicle Restraint Code			

Disclaimer:

This data is for use as one of several potential "awareness" indicators for the Ford Motor Co. Enhanced Concern Identification System. It is unverified, draft, summary data generated from a computer "word search" of customer and technician symptom comments. Supplier data, technician and customer comments are unverified and actual root cause of any potential issue is not established by this summary.

[Contact ODRHELP](#)

Copyright 2001 Ford Motor Co All Rights Reserved

PE12-019

Mazda

9-6-2012

REQUEST NUMBER THREE
DOCUMENTS (SUBJECT)

Consumer Reports

Mazda CAC

ECI

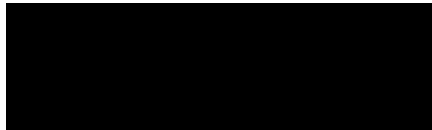



Concern Driven Reporting

Report Detail

Note: Field which are grayed (ghosted) are currently being mapped to the data warehouse. They are not presently being populated.

ECI Record		Source Code	MAZDA CAC
------------	--	-------------	-----------

Commodity Assignment

Commodity	powertrain-engine-accel pedal/linkage/controls	Symptom	no keyword found
Commodity	powertrain-engine-accel pedal/linkage/controls	Symptom	pedal concerns-accelerator pedal
Commodity	powertrain-engine-accel pedal/linkage/controls	Symptom	sticks/binds/grabs
Commodity	powertrain-engine-air induction-throttle body-	Symptom	no keyword found
Commodity	powertrain-engine-air induction-throttle body-	Symptom	sticks/binds/grabs
Significant Event		Verified	N

Tread Information

Reported in Tread Quarter	Q4 2004
---------------------------	---------

Report Details

Source Claim Key		Warranty Component Classification (WCC)	
Corporate Product Systems Classification (CPSC)		Time in Service	10
Customer Condition Code		V Function Group (VFG)	
Source System Program Type		Repair/Report/Paid Date	29-Nov-2004
Version Series Code	AAAQK	Load Date	05-Dec-2004
Causal Part Prefix-Base-Suffix	-	Dealer Code	UNKNOW
Causal Part Name	unknown	Dealer Name	
Non Causal Part Prefix-Base-Suffix		Dealer City	
Non Causal Part Numbers		Dealer State/Province	
Fault Code		Dealer Country	UNK
Diagnostic Trouble Code		Dealer Phone Number	
Labor Operation Code		Attachment	
Communication Type		VOQ Component Description Code	
Maintenance Date	05-Dec-2004		

Customer Comment	CST STS THROTTLE PLATE WAS STICKING AND HE HAD TO HAVE THROTTLE BODY REPLACED. CST STS DLR ADV HIM THIS WAS NOT COVERED UNDER WARRANTY B/C IT IS A MAINTENANCE ITEM. CST INQ IF THIS IS TRUE.
Technician Comment	0012004 11 29CRPC638 REQ DESC THROTTLE PLATE STICKING ADV CST THE DLR IS CORRECT. THE THROTTLE BODY IS A MAINTENANCE ITEM AND NOT COVERED UNDER WARRANTY. CST THANKED.
CQIS Recommendations	

Tire Information

Tire Manufacturer	Unknown	Tire Size	Unknown
Tire Brand Series		Wheel	
DOT Left Front		DOT Right Front	
DOT Left Rear		DOT Right Rear	
DOT Left Inner		DOT Right Inner	
DOT Spare			

Vehicle Information

VIN	4F2CZ96194K	Engine Serial Number	
Model Year	2004	Engine Description	3.0L DOHC EGI V6 NA*G DSP2967
Transmission	4 SPD AUTO TRANS MAZDA CD4E	Vehicle Description	TRIBUTE
Body Cab Style	CA WE 5 DOOR LIGHT TRUCK	Drive Line	4 WHL L/H PART TIME DRIVE
Production Date	23-Jul-2003	Retail Sale Indicator Code	
Plant Description	KANSAS CITY PLANT BUILD	Required Vehicle	
Build Region		Warranty Start Date	19-Feb-2004
Build Country Code		Transmission Serial Number	
Mileage	0	Vehicle Axle Ratio	
Vehicle Restraint Code			

Disclaimer:

This data is for use as one of several potential "awareness" indicators for the Ford Motor Co. Enhanced Concern Identification System. It is unverified, draft, summary data generated from a computer "word search" of customer and technician symptom comments. Supplier data, technician and customer comments are unverified and actual root cause of any potential issue is not established by this summary.

[Contact ODRHELP](#)

Copyright 2001 Ford Motor Co All Rights Reserved

PE12-019

Mazda

9-6-2012

REQUEST NUMBER THREE
DOCUMENTS (SUBJECT)

Consumer Reports

Mazda CAC

ECI

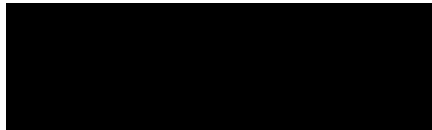



Concern Driven Reporting

Report Detail

Note: Field which are grayed (ghosted) are currently being mapped to the data warehouse. They are not presently being populated.

ECI Record		Source Code	MAZDA CAC
------------	--	-------------	-----------

Commodity Assignment

Commodity	powertrain-engine	Symptom	no keyword found
Commodity	powertrain-engine	Symptom	pedal concerns-accelerator pedal
Commodity	powertrain-engine	Symptom	sticks/binds/grabs
Commodity	powertrain-engine-accel pedal/linkage/controls	Symptom	function-malfunction/inoperative
Commodity	powertrain-engine-accel pedal/linkage/controls	Symptom	pedal concerns-accelerator pedal
Commodity	powertrain-engine-accel pedal/linkage/controls	Symptom	sticks/binds/grabs
Commodity	powertrain-engine-air induction-throttle body-	Symptom	function-malfunction/inoperative
Commodity	powertrain-engine-air induction-throttle body-	Symptom	sticks/binds/grabs
Significant Event		Verified	N

Tread Information

Reported in Tread Quarter	Q4 2004
---------------------------	---------

Report Details

Source Claim Key		Warranty Component Classification (WCC)	
Corporate Product Systems Classification (CPSC)		Time in Service	33
Customer Condition Code		V Function Group (VFG)	
Source System Program Type		Repair/Report/Paid Date	03-Dec-2004
Version Series Code	AAAA5	Load Date	19-Dec-2004
Causal Part Prefix-Base-Suffix	-	Dealer Code	61422
Causal Part Name	unknown	Dealer Name	EVERHART O'LEARY MAZDA
Non Causal Part Prefix-Base-Suffix		Dealer City	JANESVILLE
Non Causal Part Numbers		Dealer State/Province	WI
Fault Code		Dealer Country	USA
Diagnostic Trouble Code		Dealer Phone Number	
Labor Operation Code		Attachment	
Communication Type		VOQ Component Description Code	
Maintenance Date	19-Dec-2004		

Customer Comment CUST STS THAT THIS WILL BE HER 4TH TIME TO DLR FOR SAME ISSUE. CUST STS THAT WHEN YOU PRESS ON THE GAS NOTHING HAPPENS AND WHEN YOU PRESS REALLY HARD IT JUMPS DOWN AND FINALLY GOES. CUST ST SCLR FOUND CARBON BUILD UP ON THROTTLE CABLE AND FIXED, BUT IT IS STILL HAVING ISSUE.

Technician Comment ATTN SVM/DCSM/QA PLEASE REVIEW FILE AND CLOSE UPON RESOLUTION. PLEASE CONTACT TECHNICAL SUPPORT FOR ASSISTANCE. THANKS DAN MNAO 949 727 6481NOTE TO QA VEH GOING TO DLRSHIP. ADVISED CUSTOMER THAT WE CAN CLEAN THROTTLE BODY FOR STICKING.NO REALFIX FOR REPAIR OUT AT THIS TIME,CUSTOMER WILL COME IN FOR REPAIR. 0012004 12 03CRPC598 AT ATTN SVM/DCSM/QA PLEASE REVIEW FILE AND CLOSE UPON RESOLUTION. PLEASE CONTACT TECHNICAL SUPPORT FOR ASSISTANCE. THANKS DAN MNAO 949 727 6481NOTE TO QA VEH GOING TO DLRSHIP. REQ DESC ACCELERATOR STICKING 0022004 12 10CRPC607 CUST CALLED STS THAT SHE IS UPSET THAT SHE HAS TO CLEAN THROTTLE BODY FOR CARBON CLEAN UP. CUST STS THAT SHE HAS HAD TO TAKE VEH TO DLR 4 TIMES FOR CLEANING. CUST WAS ADV THAT THIS IS COMMON PROBLEM ON VEH. ADV CUST TO TRY SWITCHING GAS. APOLOGIZED FOR INCONVEINCE BUT ADV CUST THIS IS MAINT ITEM THAT IS WITH ALL VEH MANUFACTURE. ADV CUST TO TRY SWITCHING GAS TO HIGHER OCTANE AND BRAND NAME GAS. ADV IF PROBLEM PERSISTS TAKE VEH TO DLR AND HAVE DLR CALL TECH LINE FOR ANY RECOMMENDED FIX

CQIS Recommendations	
----------------------	--

Tire Information

Tire Manufacturer	Unknown	Tire Size	Unknown
Tire Brand Series		Wheel	
DOT Left Front		DOT Right Front	
DOT Left Rear		DOT Right Rear	
DOT Left Inner		DOT Right Inner	
DOT Spare			

Vehicle Information

VIN	4F2YU08102K	Engine Serial Number	213228087
Model Year	2002	Engine Description	3.0L DOHC EGI V6 NA*GAS
Transmission	4 SPD AUTO TRANS MAZDA CD4E	Vehicle Description	TRIBUTE
Body Cab Style	CA WE 3 DOOR LIGHT TRUCK	Drive Line	4 WHL L/H PART TIME DRIVE
Production Date	21-Dec-2001	Retail Sale Indicator Code	
Plant Description	KANSAS CITY PLANT BUILD	Reaquired Vehicle	
Build Region		Warranty Start Date	30-Mar-2002
Build Country Code		Transmission Serial Number	
Mileage	39000	Vehicle Axle Ratio	
Vehicle Restraint Code			

Disclaimer:

This data is for use as one of several potential "awareness" indicators for the Ford Motor Co. Enhanced Concern Identification System. It is unverified, draft, summary data generated from a computer "word search" of customer and technician symptom comments. Supplier data, technician and customer comments are unverified and actual root cause of any potential issue is not established by this summary.

[Contact ODRHELP](#)

Copyright 2001 Ford Motor Co All Rights Reserved

PE12-019

Mazda

9-6-2012

REQUEST NUMBER THREE
DOCUMENTS (SUBJECT)

Consumer Reports

Mazda CAC

ECI

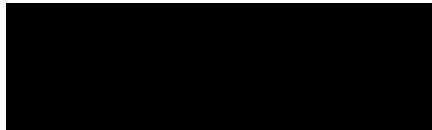



Concern Driven Reporting

Report Detail

Note: Field which are grayed (ghosted) are currently being mapped to the data warehouse. They are not presently being populated.

ECI Record		Source Code	MAZDA CAC
------------	--	-------------	-----------

Commodity Assignment

Commodity	powertrain-engine	Symptom	function-malfunction/inoperative
Commodity	powertrain-engine	Symptom	mod-driving condition-at cruise
Commodity	powertrain-engine	Symptom	no keyword found
Commodity	powertrain-engine	Symptom	pedal concerns-accelerator pedal
Commodity	powertrain-engine	Symptom	repair-prior repair mentioned
Commodity	powertrain-engine-accel pedal/linkage/controls	Symptom	function-malfunction/inoperative
Commodity	powertrain-engine-air induction-throttle body-	Symptom	function-malfunction/inoperative
Significant Event		Verified	N

Tread Information

Reported in Tread Quarter	Q4 2004
---------------------------	---------

Report Details

Source Claim Key		Warranty Component Classification (WCC)	
Corporate Product Systems Classification (CPSC)		Time in Service	21
Customer Condition Code		V Function Group (VFG)	
Source System Program Type		Repair/Report/Paid Date	09-Dec-2004
Version Series Code	AAAQK	Load Date	19-Dec-2004
Causal Part Prefix- Base - Suffix	-	Dealer Code	23834
Causal Part Name	unknown	Dealer Name	CLASSIC MAZDA OF MOTORCARS
Non Causal Part Prefix-Base-Suffix		Dealer City	ORLANDO
Non Causal Part Numbers		Dealer State/Province	FL
Fault Code		Dealer Country	USA
Diagnostic Trouble Code		Dealer Phone Number	4078518510
Labor Operation Code		Attachment	
Communication Type		VOQ Component Description Code	
Maintenance Date	19-Dec-2004		

Customer Comment
CST STS THAT SHE WAS DRIVING VEH WITH HUSBAND AND IT ACCELERATED FROM 40 MPH TO 70 WITH OUT A NY TOUCH OF THE THE ACCELATOR. CST STS VEH AT DLR AND THEY STATE THAT THEY ARE REPAIRING THE VEH. CST STS THAT SHE IS SCARED TO DRIVE VEH. CST DOESNT WANT VEH ANYMORE.

Technician Comment
0012004 12 09CRPC609 AT ATTEN SVM/DCSM PLEASE REVIEW FILE FOR ANY POSSIBLE ASSISTANCE. PLEASE CONTACT TECH HOTLINE FOR ANY ADDITIONAL ASSISTANCE. PLEASE ADD NOTES AND CLOSE. CHRIS MNAO (949) 727 6303 REQ DESC ACCELERATOR PROBLEM ADV CUST THAT I WILL DOCUMENT THIS AND SEND TO EVERY PARTY THAT I CAN TO KEEP A GOOD RECORD OF THIS AND DO EVERYTHING WE CAN TO REPAIR THE VEH. ADV CUST THAT ALL BUYBACKS OR TRADES ARE EAITHER HANDLED BY DLR OR LEMON LAW. THANKED ADVISED OWNER THROTTLE BODY AND CABLE IS BEING REPLACED TO CORRECT CONDITION. WILL TEST DRIVE EXTENSIVELY; VEHICLE WILL BE REPAIRED BACK TO FACTORY SPECS. ATTEN SVM/DCSM PLEASE REVIEW FILE FOR ANY POSSIBLE ASSISTANCE. PLEASE CONTACT TECH HOTLINE FOR ANY ADDITIONAL ASSISTANCE. PLEASE ADD NOTES AND CLOSE. CHRIS MNAO (949) 727 6303

CQIS Recommendations

Tire Information

Tire Manufacturer	Unknown	Tire Size	Unknown
Tire Brand Series		Wheel	
DOT Left Front		DOT Right Front	
DOT Left Rear		DOT Right Rear	
DOT Left Inner		DOT Right Inner	
DOT Spare			

Vehicle Information

VIN	4F2CZ06183K	Engine Serial Number	
Model Year	2003	Engine Description	3.0L DOHC EGI V6 NA*G DSP2967
Transmission	4 SPD AUTO TRANS MAZDA CD4E	Vehicle Description	TRIBUTE
Body Cab Style	CA WE 5 DOOR LIGHT TRUCK	Drive Line	2 WHL L/H FRONT DRIVE
Production Date	31-Jan-2003	Retail Sale Indicator Code	
Plant Description	KANSAS CITY PLANT BUILD	Required Vehicle	
Build Region		Warranty Start Date	03-Apr-2003
Build Country Code		Transmission Serial Number	
Mileage	30000	Vehicle Axle Ratio	
Vehicle Restraint Code			

Disclaimer:

This data is for use as one of several potential "awareness" indicators for the Ford Motor Co. Enhanced Concern Identification System. It is unverified, draft, summary data generated from a computer "word search" of customer and technician symptom comments. Supplier data, technician and customer comments are unverified and actual root cause of any potential issue is not established by this summary.

[Contact ODRHELP](#)

Copyright 2001 Ford Motor Co All Rights Reserved

PE12-019

Mazda

9-6-2012

REQUEST NUMBER THREE
DOCUMENTS (SUBJECT)

Consumer Reports

Mazda CAC

ECI

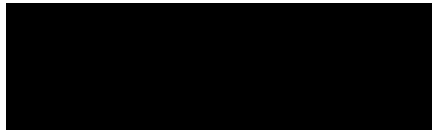



Concern Driven Reporting

Report Detail

Note: Field which are grayed (ghosted) are currently being mapped to the data warehouse. They are not presently being populated.

ECI Record		Source Code	MAZDA CAC
------------	--	-------------	-----------

Commodity Assignment

Commodity	powertrain-engine—	Symptom	function-malfunction/inoperative
Commodity	powertrain-engine—	Symptom	no keyword found
Commodity	powertrain-engine-accel pedal/linkage/controls—	Symptom	engine rpm surge/flare
Commodity	powertrain-engine-accel pedal/linkage/controls—	Symptom	improper assembly
Commodity	powertrain-engine-accel pedal/linkage/controls—	Symptom	pedal concerns-accelerator pedal
Commodity	powertrain-engine-accel pedal/linkage/controls—	Symptom	unintended acceleration
Significant Event		Verified	N

Tread Information

Reported in Tread Quarter	Q4 2004
---------------------------	---------

Report Details

Source Claim Key		Warranty Component Classification (WCC)	
Corporate Product Systems Classification (CPS)		Time in Service	14
Customer Condition Code		V Function Group (VFG)	
Source System Program Type		Repair/Report/Paid Date	27-Dec-2004
Version Series Code	AAAQK	Load Date	02-Jan-2005
Causal Part Prefix-Base-Suffix	-	Dealer Code	51495
Causal Part Name	unknown	Dealer Name	WYOMING VALLEY MAZDA
Non Causal Part Prefix-Base-Suffix		Dealer City	LARKSVILLE
Non Causal Part Numbers		Dealer State/Province	PA
Fault Code		Dealer Country	USA
Diagonstic Trouble Code		Dealer Phone Number	5702887411
Labor Operation Code		Attachment	
Communication Type		VOQ Component Description Code	
Maintenance Date	02-Jan-2005		

Customer Comment CST CALLED STD ACCELERATOR PEDAL FEELS VERY TIGHT. STD WHEN ACCELERATING EVEN SLIGHTLY, PEDAL FEELS TIGHT THEN VEH SEEMS TO SURGE FORWARD. STD WILL CONTACT DLR SVC FOR APPT / REQ CONCERN DOC'D.

Technician Comment ATTN SVC/DCSM PLEASE BE AWARE OF CUST CONCERN. PLEASE NOTATE AND CLOSE FILE WHEN POSSIBLE. THANKS, SID AT MNAO. 949 727 6413. CUSTOMER HAS NOT CONTACTED US IN REFERENCE TO THEIR PROBLEM FOR AN APPOINTMENT, AS SOON AS THEY DO COME IN WE WILL RECTIFY. 0012004 12 27CRPC294 AT ATTN SVC/DCSM PLEASE BE AWARE OF CUST CONCERN. PLEASE NOTATE AND CLOSE FILE WHEN POSSIBLE. THANKS, SID AT MNAO. 949 727 6413. REQ DESC ACCELERATOR PEDAL

CQIS Recommendations

Tire Information

Tire Manufacturer	Unknown	Tire Size	Unknown
Tire Brand Series		Wheel	
DOT Left Front		DOT Right Front	
DOT Left Rear		DOT Right Rear	
DOT Left Inner		DOT Right Inner	
DOT Spare			

Vehicle Information

VIN	4F2CZ96194K	Engine Serial Number	
Model Year	2004	Engine Description	3.0L DOHC EGI V6 NA*G DSP2967
Transmission	4 SPD AUTO TRANS MAZDA CD4E	Vehicle Description	TRIBUTE
Body Cab Style	CA WE 5 DOOR LIGHT TRUCK	Drive Line	4 WHL L/H PART TIME DRIVE
Production Date	23-Sep-2003	Retail Sale Indicator Code	
Plant Description	KANSAS CITY PLANT BUILD	Reaquired Vehicle	
Build Region		Warranty Start Date	29-Nov-2003
Build Country Code		Transmission Serial Number	
Mileage	19000	Vehicle Axle Ratio	
Vehicle Restraint Code			

Disclaimer:

This data is for use as one of several potential "awareness" indicators for the Ford Motor Co. Enhanced Concern Identification System. It is unverified, draft, summary data generated from a computer "word search" of customer and technician symptom comments. Supplier data, technician and customer comments are unverified and actual root cause of any potential issue is not established by this summary.

[Contact ODRHELP](#)

Copyright 2001 Ford Motor Co All Rights Reserved

PE12-019

Mazda

9-6-2012

REQUEST NUMBER THREE
DOCUMENTS (SUBJECT)

Consumer Reports

Mazda CAC

ECI

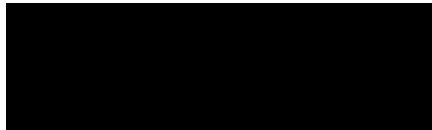



Concern Driven Reporting

Report Detail

Note: Field which are grayed (ghosted) are currently being mapped to the data warehouse. They are not presently being populated.

ECI Record		Source Code	MAZDA CAC
------------	--	-------------	-----------

Commodity Assignment			
Commodity	powertrain-engine	Symptom	engine rpm surge/flare
Commodity	powertrain-engine	Symptom	function-malfunction/inoperative
Commodity	powertrain-engine	Symptom	no keyword found
Commodity	powertrain-engine	Symptom	unintended acceleration
Commodity	powertrain-engine-accel pedal/linkage/controls	Symptom	engine rpm surge/flare
Commodity	powertrain-engine-accel pedal/linkage/controls	Symptom	mod-weather-cold
Commodity	powertrain-engine-accel pedal/linkage/controls	Symptom	unintended acceleration
Commodity	powertrain-engine-air induction-throttle body-	Symptom	engine rpm surge/flare
Commodity	powertrain-engine-air induction-throttle body-	Symptom	mod-weather-cold
Commodity	powertrain-engine-air induction-throttle body-	Symptom	unintended acceleration
Significant Event		Verified	N

Tread Information	
Reported in Tread Quarter	Q4 2004

Report Details			
Source Claim Key		Warranty Component Classification (WCC)	
Corporate Product Systems Classification (CPSC)		Time in Service	18
Customer Condition Code		V Function Group (VFG)	
Source System Program Type		Repair/Report/Paid Date	28-Dec-2004
Version Series Code	AAAQK	Load Date	06-Mar-2005
Causal Part Prefix-Base-Suffix	-	Dealer Code	23454
Causal Part Name	unknown	Dealer Name	JIM ELLIS MAZDA OF MARIETTA
Non Causal Part Prefix-Base-Suffix		Dealer City	MARIETTA
Non Causal Part Numbers		Dealer State/Province	GA
Fault Code		Dealer Country	USA
Diagnostic Trouble Code		Dealer Phone Number	
Labor Operation Code		Attachment	
Communication Type		VOQ Component Description Code	
Maintenance Date	06-Mar-2005		

Customer Comment	CST STS ON COLD MORNINGS WHEN YOU GIVE THE VEH A LITTLE GAS THE VEH SURGES. CST STS CONTACTED THE DLR AND THEY ADV THAT THIS IS PROBABLY DUE TO THE WAY THE GAS BURNS AND THE THROTTLE BODY WILL MOST LIKELY NEED TO BE CLEANED.DLR HAS ADV THIS WILL COST \$300. CST INQ WHAT CAN BE DONE. HE IS STILL WITHIN WARRANTY AND DOES NOT WANT TO PAY.
Technician Comment	CLOSING REQUEST. DID NOT HEAR BACK FROM CST. 0012004 12 28CRPC638 REQ DESC VEH SURGES ADV CST TO TAKE VEH TO DLR AND HAVE VEH DIAGNOSED. ONCE WE KNOW FOR SURE WHAT NEEDS TO BE DONE WE CAN LOOK INTO POSSIBLE ASSISTANCE SHOULD THE CST HAVE TO PAY FOR REPAIRS. CST STS HE WILL TRY TO WORK THIS OUT WITH THE DLR AND WILL CALL ME BACK IF HE HAS ANY FURTHER PROBLEMS OR QUESTIONS.
CQIS Recommendations	

Tire Information			
Tire Manufacturer	Unknown	Tire Size	Unknown
Tire Brand Series		Wheel	
DOT Left Front		DOT Right Front	
DOT Left Rear		DOT Right Rear	
DOT Left Inner		DOT Right Inner	
DOT Spare			

Vehicle Information			
VIN	4F2CZ06153K	Engine Serial Number	
Model Year	2003	Engine Description	3.0L DOHC EGI V6 NA*G DSP2967
Transmission	4 SPD AUTO TRANS MAZDA CD4E	Vehicle Description	TRIBUTE
Body Cab Style	CA WE 5 DOOR LIGHT TRUCK	Drive Line	2 WHL L/H FRONT DRIVE
Production Date	25-Feb-2003	Retail Sale Indicator Code	
Plant Description	KANSAS CITY PLANT BUILD	Required Vehicle	
Build Region		Warranty Start Date	30-Jul-2003
Build Country Code		Transmission Serial Number	
Mileage	0	Vehicle Axle Ratio	
Vehicle Restraint Code			

Disclaimer:

This data is for use as one of several potential "awareness" indicators for the Ford Motor Co. Enhanced Concern Identification System. It is unverified, draft, summary data generated from a computer "word search" of customer and technician symptom comments. Supplier data, technician and customer comments are unverified and actual root cause of any potential issue is not established by this summary.

[Contact ODRHELP](#)

Copyright 2001 Ford Motor Co All Rights Reserved

PE12-019

Mazda

9-6-2012

REQUEST NUMBER THREE
DOCUMENTS (SUBJECT)

Consumer Reports

Mazda CAC

ECI

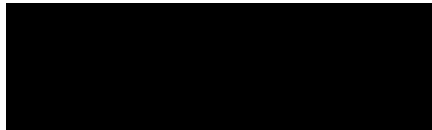



Concern Driven Reporting

Report Detail

Note: Field which are grayed (ghosted) are currently being mapped to the data warehouse. They are not presently being populated.

ECI Record		Source Code	MAZDA CAC
------------	--	-------------	-----------

Commodity Assignment

Commodity	powertrain-engine	Symptom	engine power-stall
Commodity	powertrain-engine	Symptom	function-malfunction/inoperative
Commodity	powertrain-engine	Symptom	no keyword found
Commodity	powertrain-engine-accel pedal/linkage/controls	Symptom	engine rpm surge/flare
Commodity	powertrain-engine-accel pedal/linkage/controls	Symptom	mod-child related
Commodity	powertrain-engine-accel pedal/linkage/controls	Symptom	pedal concerns-accelerator pedal
Commodity	powertrain-engine-accel pedal/linkage/controls	Symptom	sticks/binds/grabs
Significant Event		Verified	N

Tread Information

Reported in Tread Quarter	Q2 2005
---------------------------	---------

Report Details

Source Claim Key		Warranty Component Classification (WCC)	
Corporate Product Systems Classification (CPSC)		Time in Service	9
Customer Condition Code		V Function Group (VFG)	
Source System Program Type		Repair/Report/Paid Date	04-Apr-2005
Version Series Code	AAAQK	Load Date	17-Apr-2005
Causal Part Prefix-Base-Suffix	-	Dealer Code	61457
Causal Part Name	unknown	Dealer Name	JACOBS' TWIN MAZDA
Non Causal Part Prefix-Base-Suffix		Dealer City	CHICAGO
Non Causal Part Numbers		Dealer State/Province	IL
Fault Code		Dealer Country	USA
Diagnostic Trouble Code		Dealer Phone Number	
Labor Operation Code		Attachment	
Communication Type		VOQ Component Description Code	
Maintenance Date	17-Apr-2005		

Customer Comment	. CUST STS THAST SHE HAD A RECALL ON THE THROTTLE CABLE. CUST STS THAT SHE TOOK IT TO HER DLR AND THEY CHANGE THE CABLE. CUST STS THAT SHE DECIDE TO DRIVE 4 HOURS AWAY TO THE CHICAGO BULLS GAME. CUST STS THAT AFTER THE GAME HER VEH KEPT REV UP TO 500RPM AND THE THROTTLE KEPT STICKING. CUST STS THAT HER AND HER 9 YEAR OLD SON WAS IN A PARKING LOT WITH A BUNCH OF DRUNK PEOPLE AT 11 30 @ NIGHT. CUST STS THAT HER VEH WAS TOWED AND SHE HAD TO SPEND THE NIGHT @ A HOTEL.
Technician Comment	ATTN SVM/DCSM PLEASE BE AWARE OF CUSTOMER CONCERNS. PLEASE REVIEW AND CLOSE WITH COMMENTS. THANKS TERELL (949) 727 6516 REPAIRED VEHICLE RETURNED TO CUSTOMER 04.06.05. DCSM HAS AUTHORIZED REIMB FOR SOME INCIDENTAL EXPENSES IN INTEREST OF CSI. 0012005 04 04CRPC599 AT ATTN SVM/DCSM PLEASE BE AWARE OF CUSTOMER CONCERNS. PLEASE REVIEW AND CLOSE WITH COMMENTS. THANKS TERELL (949) 727 6516 REQ DESC STALLED CUST STS THAT SHE NEEDS A VEH I ADV TO GO TO ENT. CUST STS THAT SHE WILL NOT DRIVE BACK TO GET HER VEH. I ADV CUST THAT IF IT IS MAZDA FAULT THAT WE WILL REVIEW HER FILE FOR REIMBURSEMENT.
CQIS Recommendation	

Tire Information

Tire Manufacturer	Unknown	Tire Size	Unknown
Tire Brand Series		Wheel	
DOT Left Front		DOT Right Front	
DOT Left Rear		DOT Right Rear	
DOT Left Inner		DOT Right Inner	
DOT Spare			

Vehicle Information

VIN	4F2CZ96194K	Engine Serial Number	
Model Year	2004	Engine Description	3.0L DOHC EGI V6 NA*G DSP2967
Transmission	4 SPD AUTO TRANS MAZDA CD4E	Vehicle Description	TRIBUTE
Body Cab Style	CA WE 5 DOOR LIGHT TRUCK	Drive Line	4 WHL L/H PART TIME DRIVE
Production Date	13-Jun-2003	Retail Sale Indicator Code	
Plant Description	KANSAS CITY PLANT BUILD	Required Vehicle	
Build Region		Warranty Start Date	15-Jul-2004
Build Country Code		Transmission Serial Number	
Mileage	0	Vehicle Axle Ratio	
Vehicle Restraint Code			

Disclaimer:

This data is for use as one of several potential "awareness" indicators for the Ford Motor Co. Enhanced Concern Identification System. It is unverified, draft, summary data generated from a computer "word search" of customer and technician symptom comments. Supplier data, technician and customer comments are unverified and actual root cause of any potential issue is not established by this summary.

[Contact ODRHELP](#)

Copyright 2001 Ford Motor Co All Rights Reserved

PE12-019

Mazda

9-6-2012

REQUEST NUMBER THREE
DOCUMENTS (SUBJECT)

Consumer Reports

Mazda CAC

ECI

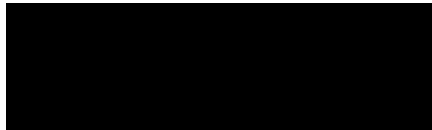



Concern Driven Reporting

Report Detail

Note: Field which are grayed (ghosted) are currently being mapped to the data warehouse. They are not presently being populated.

ECI Record		Source Code	MAZDA CAC
------------	--	-------------	-----------

Commodity Assignment

Commodity	powertrain-engine—	Symptom	no keyword found
Commodity	powertrain-engine-accel pedal/linkage/controls—	Symptom	field service action
Commodity	powertrain-engine-accel pedal/linkage/controls—	Symptom	function-malfunction/inoperative
Commodity	powertrain-engine-accel pedal/linkage/controls—	Symptom	loose
Commodity	powertrain-engine-accel pedal/linkage/controls—	Symptom	pedal concerns-accelerator pedal
Commodity	powertrain-engine-accel pedal/linkage/controls—	Symptom	sticks/binds/grabs
Significant Event		Verified	N

Tread Information

Reported in Tread Quarter	Q2 2005
---------------------------	---------

Report Details

Source Claim Key		Warranty Component Classification (WCC)	
Corporate Product Systems Classification (CPSC)		Time in Service	17
Customer Condition Code		V Function Group (VFG)	
Source System Program Type		Repair/Report/Paid Date	15-Apr-2005
Version Series Code	AAAA5	Load Date	24-Apr-2005
Causal Part Prefix- Base - Suffix	- -	Dealer Code	61454
Causal Part Name	unknown	Dealer Name	RICART MAZDA
Non Causal Part Prefix-Base-Suffix		Dealer City	GROVEPORT
Non Causal Part Numbers		Dealer State/Province	OH
Fault Code		Dealer Country	USA
Diagonstic Trouble Code		Dealer Phone Number	
Labor Operation Code		Attachment	
Communication Type		VOQ Component Description Code	
Maintenance Date	24-Apr-2005		

Customer Comment CUST IS UPSET THAT HER ACCELERATOR PEDAL STUCK AFTER SHE HAS HAD SEVERAL RECALLS ON THE VEHICLE. CUST WANTS IT DOCUMENTED THAT THE PROBLEM PUT HER IN A DANGEROUS SITUATION AND COULD HAVE CAUSED AN ACCIDENT. CUST STATES SHE WANTS TO TALK TO SOMEONE ABOUT MAZDA TAKING BACK THE VEHICLE. CUST SAYS SHE IS TAKING THE VEHICLE TO DLR 61454 TO HAVE IT FIXED

Technician Comment 0012005 04 15CRPC569 AT ATTN DCSM/SVM DLR FYI THE CUST MAY BE VISITING YOU...PLEASE UPDATE NOTES WITH REPAIR INFO AND CLOSE. THANKS, FRANK 949 727 6631 REQ DESC ACCELERATOR PEDAL STUCK VEHICLE COMPLETED ON APRIL 15 2005 RESECURED ACCELERATOR CABLE TO GAS PEDAL AND DROVE 4 MILES ALL SYSTEMS CHECKING OK AT THIS TIME ATTN DCSM/SVM DLR FYI THE CUST MAY BE VISITING YOU...PLEASE UPDATE NOTES WITH REPAIR INFO AND CLOSE. THANKS, FRANK 949 727 6631

CQIS Recommendations

Tire Information

Tire Manufacturer	Unknown	Tire Size	Unknown
Tire Brand Series		Wheel	
DOT Left Front		DOT Right Front	
DOT Left Rear		DOT Right Rear	
DOT Left Inner		DOT Right Inner	
DOT Spare			

Vehicle Information

VIN	4F2YZ94114K	Engine Serial Number	
Model Year	2004	Engine Description	3.0L DOHC EGI V6 NA*G DSP2967
Transmission	4 SPD AUTO TRANS MAZDA CD4E	Vehicle Description	TRIBUTE
Body Cab Style	CA WE 5 DOOR LIGHT TRUCK	Drive Line	4 WHL L/H PART TIME DRIVE
Production Date		Retail Sale Indicator Code	
Plant Description	KANSAS CITY PLANT BUILD	Required Vehicle	
Build Region		Warranty Start Date	30-Nov-2003
Build Country Code		Transmission Serial Number	
Mileage	0	Vehicle Axle Ratio	
Vehicle Restraint Code			

Disclaimer:

This data is for use as one of several potential "awareness" indicators for the Ford Motor Co. Enhanced Concern Identification System. It is unverified, draft, summary data generated from a computer "word search" of customer and technician symptom comments. Supplier data, technician and customer comments are unverified and actual root cause of any potential issue is not established by this summary.

[Contact ODRHELP](#)

Copyright 2001 Ford Motor Co All Rights Reserved

PE12-019

Mazda

9-6-2012

REQUEST NUMBER THREE
DOCUMENTS (SUBJECT)

Consumer Reports

Mazda CAC

ECI

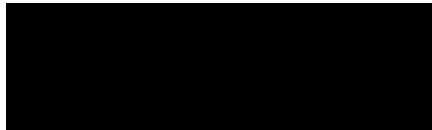



Concern Driven Reporting

Report Detail

Note: Field which are grayed (ghosted) are currently being mapped to the data warehouse. They are not presently being populated.

ECI Record		Source Code	MAZDA CAC
------------	--	-------------	-----------

Commodity Assignment

Commodity	powertrain-engine—	Symptom	repair-prior repair mentioned
Commodity	powertrain-engine-accel pedal/linkage/controls—	Symptom	function-malfunction/inoperative
Commodity	powertrain-engine-accel pedal/linkage/controls—	Symptom	pedal concerns-accelerator pedal
Commodity	powertrain-engine-accel pedal/linkage/controls—	Symptom	repair-prior repair mentioned
Commodity	powertrain-engine-accel pedal/linkage/controls—	Symptom	sticks/binds/grabs
Commodity	powertrain-engine-air induction-throttle body-	Symptom	function-malfunction/inoperative
Commodity	powertrain-engine-air induction-throttle body-	Symptom	repair-prior repair mentioned
Commodity	powertrain-engine-air induction-throttle body-	Symptom	sticks/binds/grabs
Significant Event		Verified	N

Tread Information

Reported in Tread Quarter	Q2 2005
---------------------------	---------

Report Details

Source Claim Key		Warranty Component Classification (WCC)	
Corporate Product Systems Classification (CPSC)		Time in Service	9
Customer Condition Code		V Function Group (VFG)	
Source System Program Type		Repair/Report/Paid Date	04-May-2005
Version Series Code	AAAGH	Load Date	22-May-2005
Causal Part Prefix-Base-Suffix	-	Dealer Code	50360
Causal Part Name	unknown	Dealer Name	RAY PRICE MAZDA
Non Causal Part Prefix-Base-Suffix		Dealer City	EAST STROUDSBURG
Non Causal Part Numbers		Dealer State/Province	PA
Fault Code		Dealer Country	USA
Diagnostic Trouble Code		Dealer Phone Number	5704762800
Labor Operation Code		Attachment	
Communication Type		VOQ Component Description Code	
Maintenance Date	22-May-2005		

Customer Comment	CUST IS UPSET THAT THE THROTTLE BODY REPLACEMENT 2ND TIME IS CAUSING PROBLEMS FOR HIM AND HIS WIFE AS THEY ARE AFRAID OF DRIVING THE VEHICLE AS THIS REPAIR DID NOT FIX THE STICKING ACCELERATOR LAST TIME. CUST ASKING TO HAVE HIS CONCERNS ABOUT THE VEHICLE DOCUMENTED AS THEY FEEL THE VEHICLE WILL GET IN A CRASH. CUST ALSO ADVISED THAT HE IS CONSIDERING THE LEMON LAW		
Technician Comment	ATTN DCSM/SVM PLEASE REVEIW FILE FOR CUSTOMER CONCERNS. DLR PLEASE PUT IN CLOSING NOTES WITH DOCUMENTATION AFTER REPAIR IS COMPLETED. DCSM FYI THE CUST IS ASKING ABOUT LEMON LAW. THANKS, FRANK 949 727 6631 THROTTLE STICK CHECK VEHICLE OVER CALL TECH IN REF: [REDACTED] REPLACE THROTTLE BODY AND CHEKC AFTER REPAIRS OPERATING OK 0012005 05 04CRPC569 AT ATTN DCSM/SVM PLEASE REVEIW FILE FOR CUSTOMER CONCERNS. DLR PLEASE PUT IN CLOSING NOTES WITH DOCUMENTATION AFTER REPAIR IS COMPLETED. DCSM FYI THE CUST IS ASKING ABOUT LEMON LAW. THANKS, FRANK 949 727 6631 REQ DESC THROTTLE BODY REPLACEMENT 2ND TIME		
CQIS Recommendations			

Tire Information

Tire Manufacturer	Unknown	Tire Size	Unknown
Tire Brand Series		Wheel	
DOT Left Front		DOT Right Front	
DOT Left Rear		DOT Right Rear	
DOT Left Inner		DOT Right Inner	
DOT Spare			

Vehicle Information

VIN	4F2YZ92Z95K [REDACTED]	Engine Serial Number	
Model Year	2005	Engine Description	2.3L DOHC EGI I4 I6V NA GAS
Transmission	4 SPD AUTO TRANS MAZDA CD4E	Vehicle Description	TRIBUTE
Body Cab Style	CA WE 5 DOOR LIGHT TRUCK	Drive Line	4 WHL L/H PART TIME DRIVE
Production Date	17-May-2004	Retail Sale Indicator Code	
Plant Description	KANSAS CITY PLANT BUILD	Required Vehicle	
Build Region		Warranty Start Date	20-Aug-2004
Build Country Code		Transmission Serial Number	
Mileage	5000	Vehicle Axle Ratio	
Vehicle Restraint Code			

Disclaimer:

This data is for use as one of several potential "awareness" indicators for the Ford Motor Co. Enhanced Concern Identification System. It is unverified, draft, summary data generated from a computer "word search" of customer and technician symptom comments. Supplier data, technician and customer comments are unverified and actual root cause of any potential issue is not established by this summary.

[Contact ODRHELP](#)

Copyright 2001 Ford Motor Co All Rights Reserved

PE12-019

Mazda

9-6-2012

REQUEST NUMBER THREE
DOCUMENTS (SUBJECT)

Consumer Reports

Mazda CAC

ECI

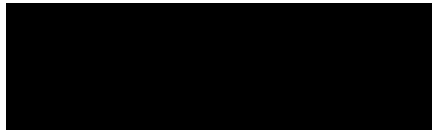



Concern Driven Reporting

Report Detail

Note: Field which are grayed (ghosted) are currently being mapped to the data warehouse. They are not presently being populated.

ECI Record		Source Code	MAZDA CAC
------------	--	-------------	-----------

Commodity Assignment			
Commodity	powertrain-engine	Symptom	no keyword found
Commodity	powertrain-engine-accel pedal/linkage/controls	Symptom	pedal concerns-accelerator pedal
Significant Event		Verified	N

Tread Information	
Reported in Tread Quarter	Q2 2005

Report Details			
Source Claim Key		Warranty Component Classification (WCC)	
Corporate Product Systems Classification (CPSC)		Time in Service	
Customer Condition Code		V Function Group (VFG)	
Source System Program Type		Repair/Report/Paid Date	24-Jun-2005
Version Series Code		Load Date	26-Jun-2005
Causal Part Prefix- Base - Suffix	-	Dealer Code	UNKNOW
Causal Part Name	unknown	Dealer Name	
Non Causal Part Prefix-Base-Suffix		Dealer City	
Non Causal Part Numbers		Dealer State/Province	
Fault Code		Dealer Country	USA
Diagnostic Trouble Code		Dealer Phone Number	
Labor Operation Code		Attachment	
Communication Type		VOQ Component Description Code	
Maintenance Date	26-Jun-2005		

Customer Comment	CASE# [REDACTED] CUST STS THAT WHEN HE PUSHES ON THE GAS THERE IS A HARD SPOT WHILE PRESSING DOWN BUT ONCE YOU GET PAST THAT POINT EVERYTHIN GIS FINE. CUST WONDERING OUR THOUGHTS ON IT.
Technician Comment	0012005 06 24CRPC598 REQ DESC TREAD ACCELERATOR PEDAL DOCUMENTATION FOR TREAD PURPOSE ADV CUST NOT TECH TRAINED. ADV CUST TO CONTACT DLR TO HAVE THEM FORMALLY DIAG CONCERN AS THIS IS NOT SOMETHIGN CAN DIAG OVER E MAIL.
CQIS Recommendations	

Tire Information			
Tire Manufacturer	Unknown	Tire Size	Unknown
Tire Brand Series		Wheel	
DOT Left Front		DOT Right Front	
DOT Left Rear		DOT Right Rear	
DOT Left Inner		DOT Right Inner	
DOT Spare			

Vehicle Information			
VIN	4F2YZ0Z35K [REDACTED]	Engine Serial Number	
Model Year	2005	Engine Description	2.3L DOHC EGI I4 16V NA GAS
Transmission	4 SPD AUTO TRANS MAZDA CD4E	Vehicle Description	TRIBUTE
Body Cab Style	Unknown	Drive Line	2 WHL L/H FRONT DRIVE
Production Date	11-Oct-2004	Retail Sale Indicator Code	
Plant Description	KANSAS CITY PLANT BUILD	Required Vehicle	
Build Region		Warranty Start Date	29-Sep-2009
Build Country Code		Transmission Serial Number	
Mileage	0	Vehicle Axle Ratio	
Vehicle Restraint Code			

Disclaimer:

This data is for use as one of several potential "awareness" indicators for the Ford Motor Co. Enhanced Concern Identification System. It is unverified, draft, summary data generated from a computer "word search" of customer and technician symptom comments. Supplier data, technician and customer comments are unverified and actual root cause of any potential issue is not established by this summary.

PE12-019

Mazda

9-6-2012

REQUEST NUMBER THREE
DOCUMENTS (SUBJECT)

Consumer Reports

Mazda CAC

ECI

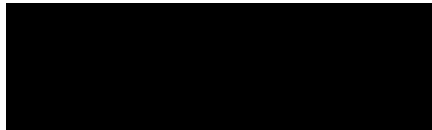



Concern Driven Reporting

Report Detail

Note: Field which are grayed (ghosted) are currently being mapped to the data warehouse. They are not presently being populated.

ECI Record		Source Code	MAZDA CAC
------------	--	-------------	-----------

Commodity Assignment			
Commodity	powertrain-engine	Symptom	administrative cost
Commodity	powertrain-engine	Symptom	charge-low/no/under
Commodity	powertrain-engine	Symptom	engine power-misfire/runs rough
Commodity	powertrain-engine	Symptom	engine power-stall
Commodity	powertrain-engine	Symptom	function-malfunction/inoperative
Commodity	powertrain-engine	Symptom	no keyword found
Commodity	powertrain-engine-accel pedal/linkage/controls	Symptom	administrative cost
Commodity	powertrain-engine-accel pedal/linkage/controls	Symptom	engine power-stall
Commodity	powertrain-engine-accel pedal/linkage/controls	Symptom	function-malfunction/inoperative
Commodity	powertrain-engine-accel pedal/linkage/controls	Symptom	misaligned/out of position/adjustment/poor fit
Commodity	powertrain-engine-accel pedal/linkage/controls	Symptom	mod-driving condition-at idle
Commodity	powertrain-engine-electronic engine control	Symptom	function-malfunction/inoperative
Commodity	powertrain-engine-electronic engine control	Symptom	misaligned/out of position/adjustment/poor fit
Commodity	powertrain-engine-electronic engine control	Symptom	mod-driving condition-at idle
Commodity	powertrain-engine-electronic engine control module-	Symptom	administrative cost
Commodity	powertrain-engine-electronic engine control module-	Symptom	engine power-stall
Commodity	powertrain-engine-electronic engine control module-	Symptom	function-malfunction/inoperative
Significant Event		Verified	N

Tread Information	
Reported in Tread Quarter	Q3 2005

Report Details			
Source Claim Key		Warranty Component Classification (WCC)	
Corporate Product Systems Classification (CPSC)		Time in Service	38
Customer Condition Code		V Function Group (VFG)	
Source System Program Type		Repair/Report/Paid Date	07-Sep-2005
Version Series Code	AAAA5	Load Date	11-Sep-2005
Causal Part Prefix-Base-Suffix	-	Dealer Code	23794
Causal Part Name	NOT PROVIDED BY SOURCE	Dealer Name	CORY FAIRBANKS MAZDA
Non Causal Part Prefix-Base-Suffix		Dealer City	LONGWOOD
Non Causal Part Numbers		Dealer State/Province	FL
Fault Code		Dealer Country	USA
Diagonstic Trouble Code		Dealer Phone Number	
Labor Operation Code		Attachment	
Communication Type		VOQ Component Description Code	
Maintenance Date	11-Sep-2005		

Customer Comment	CST STS VEH WOULD START BUT WON'T IDLE. STS TOOK VEH INTO DLR SAT & LEFT IT OVER WEEKEND. STS CALLED 2X TUES & TOLD VEH READY, REPAIR COST \$135. CST STS VEH WANTED TO STOP WHEN SHE BEGAN TO DRIVE OFF. STS TT DLR & THEY TOOK BACK VEH & PUT CST ON RENTAL. CST STS TOLD THAT SHE HAS TO PAY FOR ADDITIONAL REPAIRS. STS TT SVM & TOLD PROB COULD HAVE HAPPENED AFTER. CST STS REFUSES TO PAY MORE.
Technician Comment	0052005 09 08CRPC568 WE REPAIRED THE VEHICLE NO CHARGE TO CUSTOMER 0042005 09 07CRPC568 STS WILL NOT PAY ANYTHING. 0032005 09 07CRPC568 SENT OUT E MAIL TO CAC ADV TO FWD CST TO ME. CST CALLED & GAVE [REDACTED] C/B # [REDACTED] CALLED CST & ADV DLR DID FIND PROB W/TPS AND ADJUSTED IDLE. ADV THAT VEH IDLED FOR 4 HRS & THAT THEY TEST DROVE VEH & IT WAS FINE. ADV ONCE PROB WAS DISCOVERED, DLR TOOK IN VEH AND DIAG, PUT CST IN RENTAL WHICH DLR IS PAYING FOR. DLR WAS GOING TO COVER REPAIR WHEN HUSBAND CALLED & TOLD DLR THEY WOULD PAY FOR REPAIR. STS DLR GIVING CST DISCOUNT ON PARTS AND NOT CHARGING LABOR. CST STS THE VEH IS HERS NOT HER HUSBANDS. STS HUSBAND IS IN GA. 0022005 09 07CRPC568 CALLED DLR AND TT SVA BILL, PUT ON HOLD, DLR GETTING SVM. SVA JOHN, DID ADJUST ON TPS IDLED FOR 4HRS, DID TEST DRIVE. VEH STALLED ON CST, BROUGHT BACK. DLR SAID WILL LOOK @ VEH & PUT CST IN RENTAL. FOUND BAD IAC MOTOR, SVM TT CST & TOLD HER DLR WILL PUT ON PART NO CHARGE. 5 MINUTES LATER HUSBAND CALLED, HUSBAND SAID THEY WOULD PAY FOR PART. DLR GAVE DISCOUNT ON PART & PUTTING PART ON FOR NO CHARGE FOR LABOR. DEALER PAYING FOR RENTAL. CST DISCONNECTED FROM CALL. CALLED CST #, CST NOT AVAIL. LFT MSG FOR C/B W/LESLIE. 0012005 09 07CRPC568 AT ADV CST DLR PROVIDED HER W/RENTAL, IS GIVING HER A DEAL ON THE PART, & NOT CHARGING ANYTHING FOR LABOR. ADV CST HER HUSBAND CALLED DLR AND TOLD DLR TO CHARGE FOR PART. CST STS THE VEHICLE IS HERS. STS HER HUSBAND IS IN GA & DOESN'T KNOW WHAT HE IS TALKING ABOUT. CST STS SHE WILL NOT PAY FOR ANYTHING. RECOMMEND CST TT HER HUSBAND & TO DLR. PLS0000 N0REQ DESC VEH WON'T IDLE PUT CST ON HOLD AND CALLED DLR & ASKED FOR SVM, SVM NOT ANSWERING GIVEN SVM MOBILE #404 402 6664. CALLED # & GOT V/M. WE REPAIRED THE VEHICLE NO CHARGE TO CUSTOMER ADV CST DLR PROVIDED HER W/RENTAL, IS GIVING HER A DEAL ON THE PART, & NOT CHARGING ANYTHING FOR LABOR. ADV CST HER HUSBAND CALLED DLR AND TOLD DLR TO CHARGE FOR PART. CST STS THE VEHICLE IS HERS. STS HER HUSBAND IS IN GA & DOESN'T KNOW WHAT HE IS TALKING ABOUT. CST STS SHE WILL NOT PAY FOR ANYTHING. RECOMMEND CST TT HER HUSBAND & TO DLR. PLS

CQIS Recommendation	
---------------------	--

Tire Information			
Tire Manufacturer	Unknown	Tire Size	Unknown
Tire Brand Series		Wheel	
DOT Left Front		DOT Right Front	
DOT Left Rear		DOT Right Rear	
DOT Left Inner		DOT Right Inner	
DOT Spare			

Vehicle Information			
VIN	4F2YU09172K [REDACTED]	Engine Serial Number	338596087
Model Year	2002	Engine Description	3.0L DOHC EGI V6 NA*GAS
Transmission	4 SPD AUTO TRANS MAZDA CD4E	Vehicle Description	TRIBUTE
Body Cab Style	CA WE 3 DOOR LIGHT TRUCK	Drive Line	2 WHL L/H FRONT DRIVE
Production Date	26-Jun-2002	Retail Sale Indicator Code	
Plant Description	KANSAS CITY PLANT BUILD	Required Vehicle	
Build Region		Warranty Start Date	04-Aug-2002
Build Country Code		Transmission Serial Number	
Mileage	51000	Vehicle Axle Ratio	
Vehicle Restraint Code			

Disclaimer:

This data is for use as one of several potential "awareness" indicators for the Ford Motor Co. Enhanced Concern Identification System. It is unverified, draft, summary data generated from a computer "word search" of customer and technician symptom comments. Supplier data, technician and customer comments are unverified and actual root cause of any potential issue is not established by this summary.

[Contact CDR HELP](#)
 Copyright 2001 Ford Motor Co. All Rights Reserved

PE12-019

Mazda

9-6-2012

REQUEST NUMBER THREE
DOCUMENTS (SUBJECT)

Consumer Reports

Mazda CAC

ECI

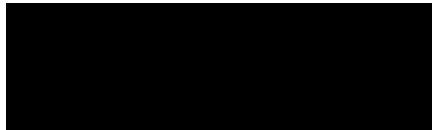



Concern Driven Reporting

Report Detail

Note: Field which are grayed (ghosted) are currently being mapped to the data warehouse. They are not presently being populated.

ECI Record		Source Code	MAZDA CAC
------------	--	-------------	-----------

Commodity Assignment

Commodity	powertrain-engine	Symptom	field service action
Commodity	powertrain-engine-accel pedal/linkage/controls	Symptom	field service action
Commodity	powertrain-engine-accel pedal/linkage/controls	Symptom	nvh-noisy operation
Commodity	powertrain-engine-accel pedal/linkage/controls	Symptom	pedal concerns-accelerator pedal
Commodity	powertrain-engine-accel pedal/linkage/controls	Symptom	sticks/binds/grabs
Significant Event		Verified	N

Tread Information

Reported in Tread Quarter	Q4 2005
---------------------------	---------

Report Details

Source Claim Key		Warranty Component Classification (WCC)	
Corporate Product Systems Classification (CPSC)		Time in Service	05
Customer Condition Code		V Function Group (VFG)	
Source System Program Type		Repair/Report/Paid Date	11-Oct-2005
Version Series Code	AAAAAX	Load Date	16-Oct-2005
Causal Part Prefix-Base-Suffix	-	Dealer Code	UNKNOW
Causal Part Name	NOT PROVIDED BY SOURCE	Dealer Name	
Non Causal Part Prefix-Base-Suffix		Dealer City	
Non Causal Part Numbers		Dealer State/Province	
Fault Code		Dealer Country	USA
Diagnostic Trouble Code		Dealer Phone Number	
Labor Operation Code		Attachment	
Communication Type		VOQ Component Description Code	
Maintenance Date	16-Oct-2005		

Customer Comment	CST STS GAS PEDAL STICKS AND HEARD OF A RECALL RELATING TO THIS
Technician Comment	ADV CST OF RECALL 1503L REGARDING SEATBELT BUCKLE...UPDATED OWNERSHIP.. 0012005 10 11CRPC606 REQ DESC RECALL INQ ADV CST OF RECALL 1503L REGARDING SEATBELT BUCKLE...UPDATED OWNERSHIP...
CQIS Recommendations	

Tire Information

Tire Manufacturer	Unknown	Tire Size	Unknown
Tire Brand Series		Wheel	
DOT Left Front		DOT Right Front	
DOT Left Rear		DOT Right Rear	
DOT Left Inner		DOT Right Inner	
DOT Spare			

Vehicle Information

VIN	4F2YU07B01K	Engine Serial Number	
Model Year	2001	Engine Description	2.0L DOHC EGI I4 NA*GAS
Transmission	5 SPD MAN TRANS MAZDA M5	Vehicle Description	TRIBUTE
Body Cab Style	CA WE 5 DOOR LIGHT TRUCK	Drive Line	2 WHL L/H FRONT DRIVE
Production Date	30-Mar-2001	Retail Sale Indicator Code	
Plant Description	KANSAS CITY PLANT BUILD	Required Vehicle	
Build Region		Warranty Start Date	18-Apr-2001
Build Country Code		Transmission Serial Number	
Mileage	144400	Vehicle Axle Ratio	
Vehicle Restraint Code			

Disclaimer:

This data is for use as one of several potential "awareness" indicators for the Ford Motor Co. Enhanced Concern Identification System. It is unverified, draft, summary data generated from a computer "word search" of customer and technician symptom comments. Supplier data, technician and customer comments are unverified and actual root cause of any potential issue is not established by this summary.

[Contact ODRHELP](#)

Copyright 2001 Ford Motor Co All Rights Reserved

PE12-019

Mazda

9-6-2012

REQUEST NUMBER THREE
DOCUMENTS (SUBJECT)

Consumer Reports

Mazda CAC

ECI

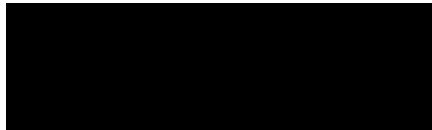



Concern Driven Reporting

Report Detail

Note: Field which are grayed (ghosted) are currently being mapped to the data warehouse. They are not presently being populated.

ECI Record		Source Code	MAZDA CAC
------------	--	-------------	-----------

Commodity Assignment			
Commodity	powertrain-engine—	Symptom	no keyword found
Commodity	powertrain-engine-accel pedal/linkage/controls—	Symptom	no keyword found
Commodity	powertrain-engine-accel pedal/linkage/controls—	Symptom	pedal concerns-accelerator pedal
Commodity	powertrain-engine-accel pedal/linkage/controls—	Symptom	sticks/binds/grabs
Commodity	powertrain-engine-air induction-throttle body-	Symptom	no keyword found
Commodity	powertrain-engine-air induction-throttle body-	Symptom	sticks/binds/grabs
Significant Event		Verified	N

Tread Information	
Reported in Tread Quarter	Q4 2005

Report Details			
Source Claim Key		Warranty Component Classification (WCC)	
Corporate Product Systems Classification (CPSC)		Time in Service	29
Customer Condition Code		V Function Group (VFG)	
Source System Program Type		Repair/Report/Paid Date	07-Dec-2005
Version Series Code	AAAQK	Load Date	11-Dec-2005
Causal Part Prefix-Base-Suffix	- -	Dealer Code	61534
Causal Part Name	NOT PROVIDED BY SOURCE	Dealer Name	LUTHER MAZDA
Non Causal Part Prefix-Base-Suffix		Dealer City	BROOKLYN CENTER
Non Causal Part Numbers		Dealer State/Province	MN
Fault Code		Dealer Country	USA
Diagonstic Trouble Code		Dealer Phone Number	7635665600
Labor Operation Code		Attachment	
Communication Type		VOQ Component Description Code	
Maintenance Date	11-Dec-2005		

Customer Comment	CST STS HIS THROTTLE HAS BEEN STICKING. CST STS DLR RECOM THROTTLE BODY CLEANING AT \$130.00 AND IT ISN'T CVRD UNDER WTTY. CST INQ WHY IT ISN'T.		
Technician Comment	0012005 12 07CRPC673 REQ DESC THROTTLE BODY CLEANING ADV CST THAT IS A SERVICE NOT NORMALLY CVRD UNDER WTTY. ADV CST I WILL REIMB HIM IF HE CAN FAX ME A PAID RECEIPT AS GOODWILL ASSISTANCE. ADV CST OF FAX NUMBER. CST THANKED. UPDATED CST ADDRESS. ADV CST THAT IS A SERVICE NOT NORMALLY CVRD UNDER WTTY. ADV CST I WILL REIMB HIM IF HE CAN FAX ME A PAID RECEIPT AS GOODWILL ASSISTANCE. ADV CST OF FAX NUMBER. CST THANKED. UPDATED CST ADDRESS.		
CQIS Recommendations			

Tire Information			
Tire Manufacturer	Unknown	Tire Size	Unknown
Tire Brand Series		Wheel	
DOT Left Front		DOT Right Front	
DOT Left Rear		DOT Right Rear	
DOT Left Inner		DOT Right Inner	
DOT Spare			

Vehicle Information			
VIN	4F2CZ961X3K	Engine Serial Number	
Model Year	2003	Engine Description	3.0L DOHC EGI V6 NA*G DSP2967
Transmission	4 SPD AUTO TRANS MAZDA CD4E	Vehicle Description	TRIBUTE
Body Cab Style	CA WE 5 DOOR LIGHT TRUCK	Drive Line	4 WHL L/H PART TIME DRIVE
Production Date	27-Feb-2003	Retail Sale Indicator Code	
Plant Description	KANSAS CITY PLANT BUILD	Reaquired Vehicle	
Build Region		Warranty Start Date	05-Aug-2003
Build Country Code		Transmission Serial Number	
Mileage	45200	Vehicle Axle Ratio	
Vehicle Restraint Code			

Disclaimer:

This data is for use as one of several potential "awareness" indicators for the Ford Motor Co. Enhanced Concern Identification System. It is unverified, draft, summary data generated from a computer "word search" of customer and technician symptom comments. Supplier data, technician and customer comments are unverified and actual root cause of any potential issue is not established by this summary.

[Contact ODRHELP](#)

Copyright 2001 Ford Motor Co All Rights Reserved

PE12-019

Mazda

9-6-2012

REQUEST NUMBER THREE
DOCUMENTS (SUBJECT)

Consumer Reports

Mazda CAC

ECI

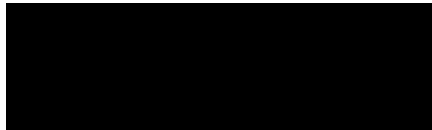



Concern Driven Reporting

Report Detail

Note: Field which are grayed (ghosted) are currently being mapped to the data warehouse. They are not presently being populated.

ECI Record		Source Code	MAZDA CAC
------------	--	-------------	-----------

Commodity Assignment			
Commodity	powertrain-engine	Symptom	no keyword found
Commodity	powertrain-engine-accel pedal/linkage/controls	Symptom	mod-driving condition-at cruise
Commodity	powertrain-engine-accel pedal/linkage/controls	Symptom	mod-driving condition-while driving
Commodity	powertrain-engine-accel pedal/linkage/controls	Symptom	mod-vehicle towed in
Commodity	powertrain-engine-accel pedal/linkage/controls	Symptom	separation
Commodity	powertrain-engine-accel pedal/linkage/controls	Symptom	sticks/binds/grabs
Commodity	powertrain-engine-exhaust-muffler/resonator	Symptom	mod-driving condition-at cruise
Commodity	powertrain-engine-exhaust-muffler/resonator	Symptom	mod-driving condition-while driving
Commodity	powertrain-engine-exhaust-muffler/resonator	Symptom	mod-vehicle towed in
Commodity	powertrain-engine-exhaust-muffler/resonator	Symptom	separation
Significant Event		Verified	N

Tread Information	
Reported in Tread Quarter	Q4 2005

Report Details			
Source Claim Key		Warranty Component Classification (WCC)	
Corporate Product Systems Classification (CPSC)		Time in Service	5
Customer Condition Code		V Function Group (VFG)	
Source System Program Type		Repair/Report/Paid Date	30-Dec-2005
Version Series Code	AAAGJ	Load Date	01-Jan-2006
Causal Part Prefix-Base-Suffix	-	Dealer Code	34525
Causal Part Name	NOT PROVIDED BY SOURCE	Dealer Name	TANNER MAZDA
Non Causal Part Prefix-Base-Suffix		Dealer City	BRAINERD
Non Causal Part Numbers		Dealer State/Province	MN
Fault Code		Dealer Country	USA
Diagnostic Trouble Code		Dealer Phone Number	
Labor Operation Code		Attachment	
Communication Type		VOQ Component Description Code	
Maintenance Date	01-Jan-2006		

Customer Comment	CST STS WHEN SHE WAS TRAVELING ON THE ROAD WITH HER FAMILY THE THROTTLE GOT STUCK, HAD TO SHUT OFF ENGINE WHEN GOING 90 MPH. STS HER AND HER FAMILY WAS NEARLY KILLED. VEH WAS TOWED TO DLR 34525 AND AFTER INSPECTION DLR STS THERE WAS A PIECE OF PLASTIC STUCK IN THE ENGINE CAUSING THE THROTTLE TO GET STUCK. PLASTIC WAS TAKEN OUT AND WHEN SHE DROVE VEH, THE MUFFLER IS COMING OFF.		
Technician Comment	0012005 12 30CRPP038 AT ATTN DCSM, SVC MGR. CUSTOMER STATES SHE AND HER FAMILY NEARLY LOST THEIR LIVES DRIVING THIS VEH. CUSTOMER IS LODGING COMPLAINT ON VEH TO LET MAZDA KNOW THAT THIS INCIDENT MAYBE HAPPENING TO OTHER VEHICLES LIKE HERS. SHE WILL BE BRING VEH IN, MUFFLER IS FALLING OFF. REQ DESC THROTTLE ADV D CST TO TAKE VEH BACK TO DLR, CONTACTED ROADSIDE;VEH TO BE TRANSPORTED BACK TO DLR TANNER MAZDA. ADV D CST TO TAKE VEH BACK TO DLR, CONTACTED ROADSIDE;VEH TO BE TRANSPORTED BACK TO DLR TANNER MAZDA. ATTN DCSM, SVC MGR. CUSTOMER STATES SHE AND HER FAMILY NEARLY LOST THEIR LIVES DRIVING THIS VEH. CUSTOMER IS LODGING COMPLAINT ON VEH TO LET MAZDA KNOW THAT THIS INCIDENT MAYBE HAPPENING TO OTHER VEHICLES LIKE HERS. SHE WILL BE BRING VEH IN, MUFFLER IS FALLING OFF.		
CQIS Recommendations			

Tire Information			
Tire Manufacturer	Unknown	Tire Size	Unknown
Tire Brand Series		Wheel	
DOT Left Front		DOT Right Front	
DOT Left Rear		DOT Right Rear	
DOT Left Inner		DOT Right Inner	
DOT Spare			

Vehicle Information			
VIN	4F2YZ96185K	Engine Serial Number	
Model Year	2005	Engine Description	3.0L DOHC EGI V6 NA*G DSP2967
Transmission	4 SPD AUTO TRANS MAZDA CD4E	Vehicle Description	TRIBUTE
Body Cab Style	CA WE 3 DOOR LIGHT TRUCK	Drive Line	4 WHL L/H PART TIME DRIVE
Production Date	11-Oct-2004	Retail Sale Indicator Code	
Plant Description	KANSAS CITY PLANT BUILD	Required Vehicle	
Build Region		Warranty Start Date	20-Aug-2005
Build Country Code		Transmission Serial Number	
Mileage	8000	Vehicle Axle Ratio	
Vehicle Restraint Code			

Disclaimer:

This data is for use as one of several potential "awareness" indicators for the Ford Motor Co. Enhanced Concern Identification System. It is unverified, draft, summary data generated from a computer "word search" of customer and technician symptom comments. Supplier data, technician and customer comments are unverified and actual root cause of any potential issue is not established by this summary.

[Contact ODRHELP](#)

Copyright 2001 Ford Motor Co All Rights Reserved

PE12-019

Mazda

9-6-2012

REQUEST NUMBER THREE
DOCUMENTS (SUBJECT)

Consumer Reports

Mazda CAC

ECI

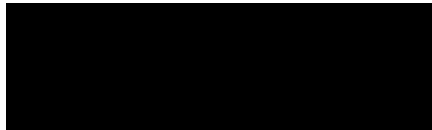



Concern Driven Reporting

Report Detail

Note: Field which are grayed (ghosted) are currently being mapped to the data warehouse. They are not presently being populated.

ECI Record		Source Code	MAZDA CAC
------------	--	-------------	-----------

Commodity Assignment

Commodity	powertrain-engine	Symptom	mod-driving condition-on acceleration
Commodity	powertrain-engine	Symptom	mod-driving condition-while driving
Commodity	powertrain-engine	Symptom	no keyword found
Commodity	powertrain-engine	Symptom	pedal concerns-accelerator pedal
Commodity	powertrain-engine-accel pedal/linkage/controls	Symptom	loss of control
Commodity	powertrain-engine-accel pedal/linkage/controls	Symptom	pedal concerns-accelerator pedal
Significant Event		Verified	Y

Tread Information

Reported in Tread Quarter	Q2 2006
---------------------------	---------

Report Details

Source Claim Key		Warranty Component Classification (WCC)	
Corporate Product Systems Classification (CPSC)		Time in Service	31
Customer Condition Code		V Function Group (VFG)	
Source System Program Type		Repair/Report/Paid Date	15-Jun-2006
Version Series Code	AAAA5	Load Date	18-Jun-2006
Causal Part Prefix-Base-Suffix	--	Dealer Code	70927
Causal Part Name	NOT PROVIDED BY SOURCE	Dealer Name	FRANK BOMMARITO MAZDA
Non Causal Part Prefix-Base-Suffix		Dealer City	ELLISVILLE
Non Causal Part Numbers		Dealer State/Province	MO
Fault Code		Dealer Country	USA
Diagonstic Trouble Code		Dealer Phone Number	6363910073
Labor Operation Code		Attachment	
Communication Type		VOQ Component Description Code	
Maintenance Date	18-Jun-2006		

Customer Comment CUST CALLED, STATES SHE WAS ADVISED BY THE DLR TO CALL HERE AND GET A CASE NUMBER....SO THAT AN INVESTIGATOR CAN COME OUT AND LOOK AT THE VEH.CUST STATES THAT VEHICLE REVERSED OUT OF THE DRIVEWAY AND HIT 2 TRESS AND CAME TO A STOP. CUST STATES NO INJURIES.VEH IS AT BOMMARITO MAZDA.

Technician Comment 0032006 06 16CRPP921 CUSTOMER CONT BY CUSTOMER ON 16 JUNE 2006 AT 1445 ADVISED CUSTOMER THAT VEHICLE WAS INSPECTED BY DCSM ERIC NAPPLE ON THIS DATE AT APPX 10AM AND HIS INFORMATION FORWARDED TO CORP FORCONSIDERATION. CUST ASKED MY OPINION AND EXPLAINED TO HI THAT A AFT RUBBER FLOOR MAT HAD BEEN INSTALLED OVER THE FAC CARPET MAT AND WAS INTERFERRING WITH THE THROTTLE PEDAL. CUST AGREED FINDAND THE FACT THAT HIS 16 YEAR OLD SON WAS DRIVING IS TURNING IT OVER TO HIS INSURANCE TO REPAIR 0022006 06 15CRPP921 AS ACTUALLY SIDESWIPED BY ANOTHER VEH WHILE LEAVING THE DRIVEWAY AFTERWICH LOSS OF CONTROL OCCURED. STATES VEH IS CURRENTLY AT THE DLR BODYSHOP. SM TO ADD NECESSARY COMMENTS IN FILE. SM CALLED BACK, STATES CUST HAS 2 FLOOR MATS IN THE DRIVERS SIDE AND ARE BUNCHED UP WITH THE ACCELERATOR PEDAL. SM STATES THAT HE IS TAKING PICTURES OF THE SITUATION AND WILL CONTACT HIS DCSM AND INFORM OF THE SITUATION AND FORWARD HIM PICS IF NECESSARY OR HAVE DCSM LOOK AT THE VEH. 0012006 06 15CRPP921 AT ATTN DCSM/SVM PER CONVERSATION, PLEASE REVIEW REQUEST. PLEASE CONTACT THE DCSM FOR POSSIBLE GOODWILL. PLEASE CONTACT TECH SUPPORT IF NECESSARY. PLEASE CLOSE UPON RESOLUTION. THANKS. DAN (949) 727 6888 REQ DESC VEH ACCELERATED AND HIT 2 TREES ADVISED CUST THAT HER ISSUE IS DOCUMENTED, ISSUED FILE NUMBER AND ADVISED WILL FORWARD CASE TO THE DLR AND SPEAK WITH THE SM ON THE ISSUE. CALLED THE DLR AND SPOKE WITH THE SM WHO INDICATED VEHICLE W CUSTOMER CONT BY CUSTOMER ON 16 JUNE 2006 AT 1445 ADVISED CUSTOMER THAT VEHICLE WAS INSPECTED BY DCSM ERIC NAPPLE ON THIS DATE AT APPX 10AM AND HIS INFORMATION FORWARDED TO CORP FORCONSIDERATION. CUST ASKED MY OPINION AND EXPLAINED TO HI THAT A AFT RUBBER FLOOR MAT HAD BEEN INSTALLED OVER THE FAC CARPET MAT AND WAS INTERFERRING WITH THE THROTTLE PEDAL. CUST AGREED FINDAND THE FACT THAT HIS 16 YEAR OLD SON WAS DRIVING IS TURNING IT OVER TO HIS INSURANCE TO REPAIR ATTN DCSM/SVM PER CONVERSATION. PLEASE REVIEW REQUEST. PLEASE CONTACT THE DCSM FOR POSSIBLE GOODWILL. PLEASE CONTACT TECH SUPPORT IF NECESSARY. PLEASE CLOSE UPON RESOLUTION. THANKS. DAN (949) 727 6888

CQIS Recommendations

Tire Information

Tire Manufacturer	Unknown	Tire Size	Unknown
Tire Brand Series		Wheel	
DOT Left Front		DOT Right Front	
DOT Left Rear		DOT Right Rear	
DOT Left Inner		DOT Right Inner	
DOT Spare			

Vehicle Information

VIN	4F2YZ04114K	Engine Serial Number	
Model Year	2004	Engine Description	3.0L DOHC EGI V6 NA*G DSP2967
Transmission	4 SPD AUTO TRANS MAZDA CD4E	Vehicle Description	TRIBUTE

Body Cab Style	CA WE 5 DOOR LIGHT TRUCK	Drive Line	2 WHL L/H FRONT DRIVE
Production Date	18-Jun-2003	Retail Sale Indicator Code	
Plant Description	KANSAS CITY PLANT BUILD	Reaquired Vehicle	
Build Region		Warranty Start Date	05-Dec-2003
Build Country Code		Transmission Serial Number	
Mileage	30000	Vehicle Axle Ratio	
Vehicle Restraint Code			

Disclaimer:

This data is for use as one of several potential "awareness" indicators for the Ford Motor Co. Enhanced Concern Identification System. It is unverified, draft, summary data generated from a computer "word search" of customer and technician symptom comments. Supplier data, technician and customer comments are unverified and actual root cause of any potential issue is not established by this summary.

[Contact CDR HELP](#)

Copyright 2001 Ford Motor Co. All Rights Reserved

PE12-019

Mazda

9-6-2012

REQUEST NUMBER THREE
DOCUMENTS (SUBJECT)

Consumer Reports

Mazda CAC

ECI

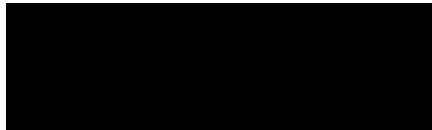



Concern Driven Reporting

Report Detail

Note: Field which are grayed (ghosted) are currently being mapped to the data warehouse. They are not presently being populated.

ECI Record		Source Code	MAZDA CAC
------------	--	-------------	-----------

Commodity Assignment			
Commodity	powertrain-engine—	Symptom	field service action
Commodity	powertrain-engine—	Symptom	part-missing part
Commodity	powertrain-engine-accel pedal/linkage/controls—	Symptom	damage
Commodity	powertrain-engine-accel pedal/linkage/controls—	Symptom	damage-catastrophic failure
Commodity	powertrain-engine-accel pedal/linkage/controls—	Symptom	field service action
Commodity	powertrain-engine-accel pedal/linkage/controls—	Symptom	mod-driving condition-at cruise
Commodity	powertrain-engine-accel pedal/linkage/controls—	Symptom	mod-driving condition-while driving
Commodity	powertrain-engine-accel pedal/linkage/controls—	Symptom	part-missing part
Commodity	powertrain-engine-accel pedal/linkage/controls—	Symptom	sticks/binds/grabs
Significant Event		Verified	N

Tread Information	
Reported in Tread Quarter	Q2 2006

Report Details			
Source Claim Key		Warranty Component Classification (WCC)	
Corporate Product Systems Classification (CPSC)		Time in Service	69
Customer Condition Code		V Function Group (VFG)	
Source System Program Type		Repair/Report/Paid Date	27-Jun-2006
Version Series Code	AAAQK	Load Date	02-Jul-2006
Causal Part Prefix- Base - Suffix	- -	Dealer Code	UNKNOW
Causal Part Name	unknown	Dealer Name	
Non Causal Part Prefix-Base-Suffix		Dealer City	
Non Causal Part Numbers		Dealer State/Province	
Fault Code		Dealer Country	USA
Diagonstic Trouble Code		Dealer Phone Number	
Labor Operation Code		Attachment	
Communication Type		VOQ Component Description Code	
Maintenance Date	02-Jul-2006		

Customer Comment	(FRIEND) CALLED FOR CST. STS CST THROTTLE STUCK, ENGINE RUINED. STS FOUND LISTING FOR RECALL ON CRUISE CONTROL CABLE
Technician Comment	ADV RECALL FOR THROTTLE CABLE DOES NOT APPEAR ON CST VEH. ADV CST VEH IS OOW. 0012006 06 27CRPC568 REQ DESC THROTTLE STUCK ADV RECALL FOR THROTTLE CABLE DOES NOT APPEAR ON CST VEH. ADV CST VEH IS OOW.
CQIS Recommendations	

Tire Information			
Tire Manufacturer	Unknown	Tire Size	Unknown
Tire Brand Series		Wheel	
DOT Left Front		DOT Right Front	
DOT Left Rear		DOT Right Rear	
DOT Left Inner		DOT Right Inner	
DOT Spare			

Vehicle Information			
VIN	4F2CU09101K	Engine Serial Number	509028039
Model Year	2001	Engine Description	3.0L DOHC EGI V6 NA*GAS
Transmission	4 SPD AUTO TRANS MAZDA CD4E	Vehicle Description	TRIBUTE
Body Cab Style	CA WE 5 DOOR LIGHT TRUCK	Drive Line	2 WHL L/H FRONT DRIVE
Production Date	19-Jul-2000	Retail Sale Indicator Code	
Plant Description	KANSAS CITY PLANT BUILD	Reaquired Vehicle	
Build Region		Warranty Start Date	28-Oct-2000
Build Country Code		Transmission Serial Number	
Mileage	94000	Vehicle Axle Ratio	
Vehicle Restraint Code			

Disclaimer:

This data is for use as one of several potential "awareness" indicators for the Ford Motor Co. Enhanced Concern Identification System. It is unverified, draft, summary data generated from a computer "word search" of customer and technician symptom comments. Supplier data, technician and customer comments are unverified and actual root cause of any potential issue is not established by this summary.

[Contact ODRHELP](#)

Copyright 2001 Ford Motor Co All Rights Reserved

PE12-019

Mazda

9-6-2012

REQUEST NUMBER THREE
DOCUMENTS (SUBJECT)

Consumer Reports

Mazda CAC

ECI

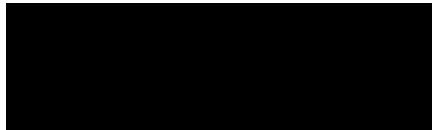



Concern Driven Reporting

Report Detail

Note: Field which are grayed (ghosted) are currently being mapped to the data warehouse. They are not presently being populated.

ECI Record		Source Code	MAZDA CAC
------------	--	-------------	-----------

Commodity Assignment			
Commodity	powertrain-engine—	Symptom	high effort
Commodity	powertrain-engine-accel pedal/linkage/controls—	Symptom	damage-cracked/fractured/split
Commodity	powertrain-engine-accel pedal/linkage/controls—	Symptom	function-malfunction/inoperative
Commodity	powertrain-engine-accel pedal/linkage/controls—	Symptom	high effort
Commodity	powertrain-engine-accel pedal/linkage/controls—	Symptom	pedal concerns-accelerator pedal
Commodity	powertrain-engine-accel pedal/linkage/controls—	Symptom	separation
Significant Event		Verified	N

Tread Information	
Reported in Tread Quarter	Q1 2007

Report Details			
Source Claim Key		Warranty Component Classification (WCC)	
Corporate Product Systems Classification (CPSC)		Time in Service	37
Customer Condition Code		V Function Group (VFG)	
Source System Program Type		Repair/Report/Paid Date	16-Jan-2007
Version Series Code	AAAA5	Load Date	21-Jan-2007
Causal Part Prefix-Base-Suffix	- -	Dealer Code	42045
Causal Part Name	unknown	Dealer Name	D DAHLE MAZDA OF MURRAY
Non Causal Part Prefix-Base-Suffix		Dealer City	MURRAY
Non Causal Part Numbers		Dealer State/Province	UT
Fault Code		Dealer Country	USA
Diagonstic Trouble Code		Dealer Phone Number	8012660033
Labor Operation Code		Attachment	
Communication Type		VOQ Component Description Code	
Maintenance Date	21-Jan-2007		

Customer Comment	CUST STS THE GAS PEDAL ACCELERATED AND THE CABLE BROKE. STS HAD THE CABLES BROKE. STS HE PAID FOR THE RPRS & THE ISSUES OCCURRED. STS ISSUE HAS NOT BEEN DIAGNOSED @ A DLRSHIP. STS WANTS A GUARANTEE BEFORE VEH IS TAKEN IN HE WILL NOT BE RESPONSIBLE FOR ENTIRE COST OF RPR. STS CONTACTED DLR42045 & FLS THEY WERE RUDE WHEN HE ASKED THEM TO COVER THE COST OF THESE RPRS.		
Technician Comment	CAS APOL & ADV'D IF CUST WISHES FOR CAC TO REVIEW FOR POSSIBLE ASSIST FIRST STEP IS TO TAKE VEH TO DLR FOR DIAGNOSIS. ADV'D W/OUT DIAGNOSIS NO ASSIST COULD BE OFFERED. CUST DECLINED AND WAS ABUSIVE TOWARDS CAS. CUST DISCONNECTED CALL. 0012007 01 16CRPP177 REQ DESC AWA ON RPR FOR ACCELERATOR PEDAL CAS APOL & ADV'D IF CUST WISHES FOR CAC TO REVIEW FOR POSSIBLE ASSIST FIRST STEP IS TO TAKE VEH TO DLR FOR DIAGNOSIS. ADV'D W/OUT DIAGNOSIS NO ASSIST COULD BE OFFERED. CUST DECLINED AND WAS ABUSIVE TOWARDS CAS. CUST DISCONNECTED CALL.		
CQIS Recommendations			

Tire Information			
Tire Manufacturer	Unknown	Tire Size	Unknown
Tire Brand Series		Wheel	
DOT Left Front		DOT Right Front	
DOT Left Rear		DOT Right Rear	
DOT Left Inner		DOT Right Inner	
DOT Spare			

Vehicle Information			
VIN	4F2YZ94124K	Engine Serial Number	003104117086
Model Year	2004	Engine Description	3.0L DOHC EGI V6 NA*G DSP2967
Transmission	4 SPD AUTO TRANS MAZDA CD4E	Vehicle Description	TRIBUTE
Body Cab Style	CA WE 5 DOOR LIGHT TRUCK	Drive Line	4 WHL L/H PART TIME DRIVE
Production Date	11-Oct-2003	Retail Sale Indicator Code	
Plant Description	KANSAS CITY PLANT BUILD	Required Vehicle	
Build Region		Warranty Start Date	17-Jan-2004
Build Country Code		Transmission Serial Number	
Mileage	53000	Vehicle Axle Ratio	
Vehicle Restraint Code			

Disclaimer:

This data is for use as one of several potential "awareness" indicators for the Ford Motor Co. Enhanced Concern Identification System. It is unverified, draft, summary data generated from a computer "word search" of customer and technician symptom comments. Supplier data, technician and customer comments are unverified and actual root cause of any potential issue is not established by this summary.

[Contact ODRHELP](#)

Copyright 2001 Ford Motor Co All Rights Reserved

PE12-019

Mazda

9-6-2012

REQUEST NUMBER THREE
DOCUMENTS (SUBJECT)

Consumer Reports

Mazda CAC

ECI

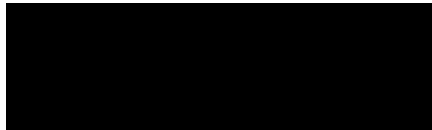



Concern Driven Reporting

Report Detail

Note: Field which are grayed (ghosted) are currently being mapped to the data warehouse. They are not presently being populated.

ECI Record		Source Code	MAZDA CAC
------------	--	-------------	-----------

Commodity Assignment			
Commodity	powertrain-engine	Symptom	engine power-stall
Commodity	powertrain-engine	Symptom	mod-driving condition-at cruise
Commodity	powertrain-engine	Symptom	mod-driving condition-while driving
Commodity	powertrain-engine	Symptom	no keyword found
Commodity	powertrain-engine	Symptom	no problem found
Commodity	powertrain-engine-accel pedal/linkage/controls	Symptom	engine power-stall
Commodity	powertrain-engine-accel pedal/linkage/controls	Symptom	mod-driving condition-at cruise
Commodity	powertrain-engine-accel pedal/linkage/controls	Symptom	mod-driving condition-while driving
Commodity	powertrain-engine-accel pedal/linkage/controls	Symptom	mod-intermittent/random
Commodity	powertrain-engine-accel pedal/linkage/controls	Symptom	pedal concerns-accelerator pedal
Commodity	powertrain-engine-accel pedal/linkage/controls	Symptom	sticks/binds/grabs
Significant Event		Verified	N

Tread Information	
Reported in Tread Quarter	Q1 2007

Report Details			
Source Claim Key		Warranty Component Classification (WCC)	
Corporate Product Systems Classification (CPS)		Time in Service	25
Customer Condition Code		V Function Group (VFG)	
Source System Program Type		Repair/Report/Paid Date	30-Mar-2007
Version Series Code	AAAGH	Load Date	01-Apr-2007
Causal Part Prefix-Base-Suffix	-	Dealer Code	51416
Causal Part Name	unknown	Dealer Name	PRESTON MAZDA
Non Causal Part Prefix-Base-Suffix		Dealer City	HURLOCK
Non Causal Part Numbers		Dealer State/Province	MD
Fault Code		Dealer Country	USA
Diagnostic Trouble Code		Dealer Phone Number	410673/171
Labor Operation Code		Attachment	
Communication Type		VOQ Component Description Code	
Maintenance Date	01-Apr-2007		

Customer Comment	CUST STS THAT SHE HAD THROTTLEBODY REPLACED AFTER REPAIR VEH STALLS WHILE DRIVING ON FREEWAY/HIGHWAY RANDOMLY. CUST IS CONCERNED AND WANTS TO KNOW WHY THE DLR CANNOT FIX. ALSO ISSUE WITH THROTTLEBODY, GAS PEDAL WAS STICKING DLR REPAIRED BUT CUST WANTED TO KNOW WHY THIS REPAIR WAS NOT UNDER WTTY.		
Technician Comment	ADV CUST OF WTTY INFO AND SVM COMMENTS. THANKED 0012007 03 30CRPP230 SM *** FYI *** PLEASE TAKE ACTION W/ CUSTOMER, AS NECESSARY. CUST STS THAT SHE WILL SELL VEH IF STALLING CONDITION IS NOT REPAIRED. WHAT ABOUT TECHLINE DO THEY HAVE FIX THANKS. CHRIS 949 727 6567 REQ DESC 2005 TRIBUTE STALLS WHILE DRIVING TT PETER SVM AT DLR. HE ADV ME THAT THEY HAD THE VEH FOR A FEW DAYS TO SEE ABOUT REPRODUCING CONDITION. DRIVEN APPROX. 40 MILES NOT SURE BUT CANNOT REPRODUCE CONDITION. STS THAT HE PUT THEM INTO A RENTAL. ALSO GAVE ME VIN FOR VEH 4F2YZ02Z15 0022007 03 30CRPP230 KM54094. ADV CUST THAT DLR AND MAZDA BELIEVE HER, HOWEVER IF DLR CANNOT REPRODUCE CONDITION THERE IS NOTHING WE CAN DO. ADV CUST THAT THE SAFETY WTTY WAS SAFETY RESTRAINT WTTY AND ONLY COVERS THE AIR BAGS AND THE SEAT BELTS. CUST ASKED IF THIS WILL BE DOCUMENTED AND I TOLD HER YES. CUST STS SHE WAS CONCERNED THAT THIS INFO WOULD HURT RESALE VALUE OF VEH. I ADV CUST THAT SERV HISTORY IS NOT REVIELED TO POTENTIAL OWNERS. ADV CUST OF WTTY INFO AND SVM COMMENTS. THANKED		
CQIS Recommendations			

Tire Information			
Tire Manufacturer	Unknown	Tire Size	Unknown
Tire Brand Series		Wheel	
DOT Left Front		DOT Right Front	
DOT Left Rear		DOT Right Rear	
DOT Left Inner		DOT Right Inner	
DOT Spare			

Vehicle Information			
VIN	4F2YZ02Z15K	Engine Serial Number	
Model Year	2005	Engine Description	2.3L DOHC EGI I4 16V NA GAS
Transmission	4 SPD AUTO TRANS MAZDA CD4E	Vehicle Description	TRIBUTE
Body Cab Style	CA WE 5 DOOR LIGHT TRUCK	Drive Line	2 WHL L/H FRONT DRIVE
Production Date	09-Feb-2005	Retail Sale Indicator Code	
Plant Description	KANSAS CITY PLANT BUILD	Reaquired Vehicle	
Build Region		Warranty Start Date	12-Mar-2005
Build Country Code		Transmission Serial Number	
Mileage	58000	Vehicle Axle Ratio	
Vehicle Restraint Code			

Disclaimer:

This data is for use as one of several potential "awareness" indicators for the Ford Motor Co. Enhanced Concern Identification System. It is unverified, draft, summary data generated from a computer "word search" of customer and technician symptom comments. Supplier data, technician and customer comments are unverified and actual root cause of any potential issue is not established by this summary.

[Contact ODRHELP](#)

Copyright 2001 Ford Motor Co All Rights Reserved

PE12-019

Mazda

9-6-2012

REQUEST NUMBER THREE
DOCUMENTS (SUBJECT)

Consumer Reports

Mazda CAC

ECI

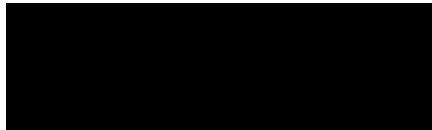



Concern Driven Reporting

Report Detail

Note: Field which are grayed (ghosted) are currently being mapped to the data warehouse. They are not presently being populated.

ECI Record		Source Code	MAZDA CAC
------------	--	-------------	-----------

Commodity Assignment

Commodity	powertrain-engine	Symptom	function-malfunction/inoperative
Commodity	powertrain-engine	Symptom	mod-driving condition-at cruise
Commodity	powertrain-engine	Symptom	mod-driving condition-while driving
Commodity	powertrain-engine	Symptom	no keyword found
Commodity	powertrain-engine	Symptom	no problem found
Commodity	powertrain-engine	Symptom	nvh-noisy operation
Commodity	powertrain-engine-accel pedal/linkage/controls	Symptom	function-malfunction/inoperative
Commodity	powertrain-engine-accel pedal/linkage/controls	Symptom	mod-driving condition-at cruise
Commodity	powertrain-engine-accel pedal/linkage/controls	Symptom	mod-driving condition-on acceleration
Commodity	powertrain-engine-accel pedal/linkage/controls	Symptom	mod-driving condition-on grade
Commodity	powertrain-engine-accel pedal/linkage/controls	Symptom	mod-driving condition-while driving
Commodity	powertrain-engine-accel pedal/linkage/controls	Symptom	nvh-noisy operation
Commodity	powertrain-engine-accel pedal/linkage/controls	Symptom	pedal concerns-accelerator pedal
Commodity	powertrain-engine-accel pedal/linkage/controls	Symptom	sticks/binds/grabs
Significant Event		Verified	Y

Tread Information

Reported in Tread Quarter	Q2 2007
---------------------------	---------

Report Details

Source Claim Key		Warranty Component Classification (WCC)	
Corporate Product Systems Classification (CPSC)		Time in Service	30
Customer Condition Code		V Function Group (VFG)	
Source System Program Type		Repair/Report/Paid Date	25-Jun-2007
Version Series Code	AAAGJ	Load Date	01-Jul-2007
Causal Part Prefix-Base-Suffix	--	Dealer Code	34347
Causal Part Name	unknown	Dealer Name	CLASSIC MAZDA
Non Causal Part Prefix-Base-Suffix		Dealer City	TEXARKANA
Non Causal Part Numbers		Dealer State/Province	TX
Fault Code		Dealer Country	USA
Diagnostic Trouble Code		Dealer Phone Number	9033346413
Labor Operation Code		Attachment	
Communication Type		VOQ Component Description Code	
Maintenance Date	01-Jul-2007		

Customer Comment	CST STS WHEN USING CRUISE CONTROL AND ACCELERATING, THE GAS PEDAL WILL HIT THE FLOOR AND THEN POP BACK UP. STS THIS IS NOT NORMAL LIKE WHEN YOU ARE GOING UP A HILL AND THE PEDAL GOES DOWN MORE BECAUSE THE ENGINE IS SPEEDING UP. STS THAT HE SPOKE TO DLR ABOUT 3 WEEKS AGO AND THEY TOLD HIM THEY HAVE NEVER HEARD OF THE ISSUE BUT WHEN HE WENT A WEEK AGO, THE DLR ADV HIM THIS IS A COMMON PROBLEM. STS CB IS [REDACTED]
Technician Comment	CAS ADV CST OF DLR CMTS. ADV CST THAT DLR IS UNABLE TO REPAIR A VEH IF THEY CANNOT PROPERLY DIAGNOSE OR DUPLICATE ISSUE. ADV CST CAN CONTACT ANOTHER DLR FOR A SECOND OPINION. CST THANKED 0012007 06 25CRPP214 REQ DESC ISSUES W/GAS PEDAL STICKING 0022007 06 26CRPP214 CAS ADV CST WILL F/U AFTER SPEAKING TO DLR. CST THANKED TT RICKY IN SVC WHO STS TECH LINE HAS NEVER HEARD OF IT AND HAVE NOT BEEN ABLE TO DUPLICATE IT. STS THAT UNSURE IF IT IS A PROBLEM OR IF THERE IS A FIX. STS ADV CST THAT IF YOU HIT AN INCLINE THE PEDAL WILL GO DOWN TO KEEP SPEED WHILE IN CRUISE CONTROL. STS HAD SEVERAL TECHS AND EMPLOYEES DRIVE VEH, NONE WHERE ABLE TO DUPLICATE CONCERN. STS NO ONE AT DLR EVER TOLD HIM THIS WAS A COMMON PROBLEM. RICKY THANKED CAS CLLD CST LEFT V/M REQ C/B. PROVIDED PH#/VDN 0032007 06 26CRPP214 CAS ADV CST OF DLR CMTS. ADV CST THAT DLR IS UNABLE TO REPAIR A VEH IF THEY CANNOT PROPERLY DIAGNOSE OR DUPLICATE ISSUE. ADV CST CAN CONTACT ANOTHER DLR FOR A SECOND OPINION. CST THANKED
CQIS Recommendations	

Tire Information

Tire Manufacturer	Unknown	Tire Size	Unknown
Tire Brand Series		Wheel	
DOT Left Front		DOT Right Front	
DOT Left Rear		DOT Right Rear	
DOT Left Inner		DOT Right Inner	
DOT Spare			

Vehicle Information

VIN	4F2YZ06135K [REDACTED]	Engine Serial Number	I04239400026
Model Year	2005	Engine Description	3.0L DOHC EGI V6 NA*G DSP2967
Transmission	4 SPD AUTO TRANS MAZDA CD4E	Vehicle Description	TRIBUTE
Body Cab Style	CA WE 5 DOOR LIGHT TRUCK	Drive Line	2 WHL L/H FRONT DRIVE
Production Date	02-Feb-2004	Retail Sale Indicator Code	
Plant Description	KANSAS CITY PLANT BUILD	Required Vehicle	
Build Region		Warranty Start Date	29-Jan-2005

Build Country Code		Transmission Serial Number	
Mileage	46000	Vehicle Axle Ratio	
Vehicle Restraint Code			

Disclaimer:

This data is for use as one of several potential "awareness" indicators for the Ford Motor Co. Enhanced Concern Identification System. It is unverified, draft, summary data generated from a computer "word search" of customer and technician symptom comments. Supplier data, technician and customer comments are unverified and actual root cause of any potential issue is not established by this summary.

[Contact CDR HELP](#)

Copyright 2001 Ford Motor Co All Rights Reserved

PE12-019

Mazda

9-6-2012

REQUEST NUMBER THREE
DOCUMENTS (SUBJECT)

Consumer Reports

Mazda CAC

ECI

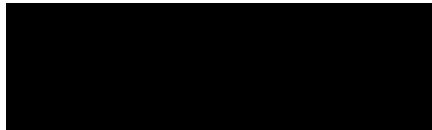



Concern Driven Reporting

Report Detail

Note: Field which are grayed (ghosted) are currently being mapped to the data warehouse. They are not presently being populated.

ECI Record		Source Code	MAZDA CAC
------------	--	-------------	-----------

Commodity Assignment			
Commodity	powertrain-engine—	Symptom	repair-prior repair mentioned
Commodity	powertrain-engine-accel pedal/linkage/controls—	Symptom	mod-no indication (sudden)
Commodity	powertrain-engine-accel pedal/linkage/controls—	Symptom	pedal concerns-accelerator pedal
Commodity	powertrain-engine-accel pedal/linkage/controls—	Symptom	repair-prior repair mentioned
Significant Event		Verified	N

Tread Information	
Reported in Tread Quarter	Q3 2007

Report Details			
Source Claim Key		Warranty Component Classification (WCC)	
Corporate Product Systems Classification (CPSC)		Time in Service	17
Customer Condition Code		V Function Group (VFG)	
Source System Program Type		Repair/Report/Paid Date	06-Aug-2007
Version Series Code	AAAGH	Load Date	12-Aug-2007
Causal Part Prefix-Base-Suffix	-	Dealer Code	42070
Causal Part Name	unknown	Dealer Name	PREMIER MAZDA
Non Causal Part Prefix-Base-Suffix		Dealer City	MILWAUKIE
Non Causal Part Numbers		Dealer State/Province	OR
Fault Code		Dealer Country	USA
Diagnostic Trouble Code		Dealer Phone Number	5033530800
Labor Operation Code		Attachment	
Communication Type		VOQ Component Description Code	
Maintenance Date	12-Aug-2007		

Customer Comment	CST. STS GAS PEDAL WILL GO TO THE FLOOR AND STAY THERE. CST STS THIS HAPPENED IN APRIL OF '06 AND AGAIN NOW. CST STS THERE IS NO WARNING OR REASON FOR PEDAL TO GO THE FLOOR. CST STS HE DOESN'T FEEL SAFE IN THE VEH. CST STS HE READ THAT IF A VEH HAS BEEN IN THE SHOP FOR 3 X MAZDA WILL TAKE THE VEH BACK.		
Technician Comment	ADV CST THAT I WILL DOC HIS CONCERN AND THIS INCIDENT. ADV CST THAT THIS IS ONLY THE SECOND TIME IN THE DLRSHIP FOR THIS REPAIR. ADV CST TO SPEAK DIRECTLY WITH THE SVC MGR OF THE DLRSHIP AS TO WHY THIS HAPPENED A SECOND TIME. 0012007 08 06CRPP206 REQ DESC GAS PEDAL ADV CST THAT I WILL DOC HIS CONCERN AND THIS INCIDENT. ADV CST THAT THIS IS ONLY THE SECOND TIME IN THE DLRSHIP FOR THIS REPAIR. ADV CST TO SPEAK DIRECTLY WITH THE SVC MGR OF THE DLRSHIP AS TO WHY THIS HAPPENED A SECOND TIME.		
CQIS Recommendations			

Tire Information			
Tire Manufacturer	Unknown	Tire Size	Unknown
Tire Brand Series		Wheel	
DOT Left Front		DOT Right Front	
DOT Left Rear		DOT Right Rear	
DOT Left Inner		DOT Right Inner	
DOT Spare			

Vehicle Information			
VIN	4F2YZ02Z16K	Engine Serial Number	160805132443
Model Year	2006	Engine Description	2.3L DOHC EGI I4 16V NA GAS
Transmission	5 SPD MAN TRANS MAZDA M5	Vehicle Description	TRIBUTE
Body Cab Style	CA WE 3 DOOR LIGHT TRUCK	Drive Line	2 WHL L/H FRONT DRIVE
Production Date	09-Sep-2005	Retail Sale Indicator Code	
Plant Description	KANSAS CITY PLANT BUILD	Required Vehicle	
Build Region		Warranty Start Date	01-Apr-2006
Build Country Code		Transmission Serial Number	
Mileage	33000	Vehicle Axle Ratio	
Vehicle Restraint Code			

Disclaimer:

This data is for use as one of several potential "awareness" indicators for the Ford Motor Co. Enhanced Concern Identification System. It is unverified, draft, summary data generated from a computer "word search" of customer and technician symptom comments. Supplier data, technician and customer comments are unverified and actual root cause of any potential issue is not established by this summary.

[Contact ODRHELP](#)

Copyright 2001 Ford Motor Co All Rights Reserved

PE12-019

Mazda

9-6-2012

REQUEST NUMBER THREE
DOCUMENTS (SUBJECT)

Consumer Reports

Mazda CAC

ECI

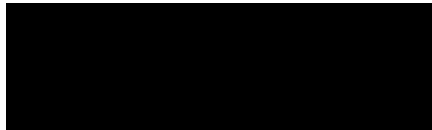



Concern Driven Reporting

Report Detail

Note: Field which are grayed (ghosted) are currently being mapped to the data warehouse. They are not presently being populated.

ECI Record		Source Code	MAZDA CAC
------------	--	-------------	-----------

Commodity Assignment

Commodity	Symptom	engine power-stall
powertrain-engine	Symptom	engine rpm surge/flare
powertrain-engine	Symptom	function-malfunction/inoperative
powertrain-engine	Symptom	high effort
powertrain-engine	Symptom	mod-driving condition-at idle
powertrain-engine	Symptom	mod-intermittent/random
powertrain-engine	Symptom	unintended acceleration
powertrain-engine-accel pedal/linkage/controls	Symptom	function-malfunction/inoperative
powertrain-engine-accel pedal/linkage/controls	Symptom	mod-driving condition-on deceleration/braking
powertrain-engine-accel pedal/linkage/controls	Symptom	nvh-noisy operation
powertrain-engine-accel pedal/linkage/controls	Symptom	unintended acceleration
powertrain-engine-air induction-throttle body-	Symptom	function-malfunction/inoperative
powertrain-engine-air induction-throttle body-	Symptom	mod-driving condition-on deceleration/braking
powertrain-engine-air induction-throttle body-	Symptom	nvh-noisy operation
powertrain-engine-air induction-throttle body-	Symptom	unintended acceleration
Significant Event	Verified	Y

Tread Information

Reported in Tread Quarter	Q3 2007
---------------------------	---------

Report Details

Source Claim Key		Warranty Component Classification (WCC)	
Corporate Product Systems Classification (CPSC)		Time in Service	75
Customer Condition Code		V Function Group (VFG)	
Source System Program Type		Repair/Report/Paid Date	14-Aug-2007
Version Series Code	AAAQK	Load Date	19-Aug-2007
Causal Part Prefix-Base-Suffix	-	Dealer Code	51571
Causal Part Name	unknown	Dealer Name	ALL STAR MAZDA
Non Causal Part Prefix-Base-Suffix		Dealer City	HEMPSTEAD
Non Causal Part Numbers		Dealer State/Province	NY
Fault Code		Dealer Country	USA
Diagnostic Trouble Code		Dealer Phone Number	5162927827
Labor Operation Code		Attachment	
Communication Type		VOQ Component Description Code	
Maintenance Date	19-Aug-2007		

Customer Comment CUST STS VEH JUMPS SPERATICLY WHEN SLOWING DOWN AND JUMPS FORWARD. STS CAR CLUNKS OUT. STS THAT DLR SAID THIS IS REOCCURRING PROBLEM IN OTHER VEH. STS CUST WAS IN ACCIDENT DUE TO NEEDED REPAIR ALL COSMETIC. STS VEH JUMPED FORWARD WHILE TRYING TO PARK AND HIT PARKED VEH. CUST STS LOOKING FOR ASSIST ON REPAIR OF THROTTLE BODY SERVICE QUOTE OF \$1120.80. CUST STS TO CALL MIKE FRACNO AT DEALER

Technician Comment ADV CUST THAT NO ASSIST WILL BE GIVEN AT THIS TIME, CUST STD THAT HE WAS GOING TO HAVE DLR EMAIL DCSM, THANKD 0012007 08 14CRPP274 REQ DESC VEH JUMPS FORWARD TT MIKE FRANCO SRV MGR STS FAXING OVER BULLETIN 0022007 08 15CRPP274 HELLO TINA, CUSTOMER CALLED IN YESTERDAY REGARDING A SITUATION ON HIS TRIBUTE INTERMITTEN ENGINE QUIT OR IDLE DIP FOR TRIBUTES 2001 2003A TSB DID GO OUT TO THE DEALERSHIP WHICH I HAD THE SRV MGR FAX OVER TO ME THIS MORNING. CUSTOMER IS AT DEALERSHIP AND WOULD LIKE MAZDA TO COVER THE AMOUNT OF COST NOTED BELOW. THE FILE DOES SHOW SERVICE HISTORY. WOULD YOU BE WILLING TO GIVE ASSISTANCE SO THEY CAN GET STARTED WORKING ON THE VEHICLE TT MIKE AT DLR STD WAITING ON RESPONSE FROM DCSM 0032007 08 15CRPP274 ADV BY DCSM TINA THAT NO ASSISTANCE WILL BE GIVEN ADV CUST THAT NO ASSIST WILL BE GIVEN AT THIS TIME, CUST STD THAT HE WAS GOING TO HAVE DLR EMAIL DCSM, THANKD

CQIS Recommendations	
----------------------	--

Tire Information

Tire Manufacturer	Unknown	Tire Size	Unknown
Tire Brand Series		Wheel	
DOT Left Front		DOT Right Front	
DOT Left Rear		DOT Right Rear	
DOT Left Inner		DOT Right Inner	
DOT Spare			

Vehicle Information

VIN	4F2CU08151K	Engine Serial Number	917996087
Model Year	2001	Engine Description	3.0L DOHC EGI V6 NA*GAS
Transmission	4 SPD AUTO TRANS MAZDA CD4E	Vehicle Description	TRIBUTE
Body Cab Style	CA WE 5 DOOR LIGHT TRUCK	Drive Line	4 WHL L/H PART TIME DRIVE
Production Date	24-May-2001	Retail Sale Indicator Code	
Plant Description	KANSAS CITY PLANT BUILD	Required Vehicle	

Build Region		Warranty Start Date	30-Jun-2001
Build Country Code		Transmission Serial Number	
Mileage	80000	Vehicle Axle Ratio	
Vehicle Restraint Code			

Disclaimer:

This data is for use as one of several potential "awareness" indicators for the Ford Motor Co. Enhanced Concern Identification System. It is unverified, draft, summary data generated from a computer "word search" of customer and technician symptom comments. Supplier data, technician and customer comments are unverified and actual root cause of any potential issue is not established by this summary.

[Contact CDR HELP](#)

Copyright 2001 Ford Motor Co All Rights Reserved

PE12-019

Mazda

9-6-2012

REQUEST NUMBER THREE
DOCUMENTS (SUBJECT)

Consumer Reports

Mazda CAC

ECI

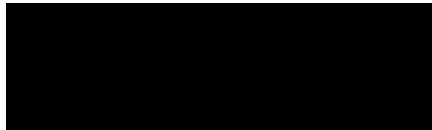



Concern Driven Reporting

Report Detail

Note: Field which are grayed (ghosted) are currently being mapped to the data warehouse. They are not presently being populated.

ECI Record		Source Code	MAZDA CAC
------------	--	-------------	-----------

Commodity Assignment			
Commodity	powertrain-engine—	Symptom	no keyword found
Commodity	powertrain-engine-accel pedal/linkage/controls—	Symptom	mod-weather-cold
Commodity	powertrain-engine-accel pedal/linkage/controls—	Symptom	mod-weather-wet
Commodity	powertrain-engine-accel pedal/linkage/controls—	Symptom	pedal concerns-accelerator pedal
Commodity	powertrain-engine-accel pedal/linkage/controls—	Symptom	start-will not start
Commodity	powertrain-engine-accel pedal/linkage/controls—	Symptom	sticks/binds/grabs
Significant Event		Verified	N

Tread Information	
Reported in Tread Quarter	Q4 2007

Report Details			
Source Claim Key		Warranty Component Classification (WCC)	
Corporate Product Systems Classification (CPSC)		Time in Service	33
Customer Condition Code		V Function Group (VFG)	
Source System Program Type		Repair/Report/Paid Date	08-Dec-2007
Version Series Code	AAAGH	Load Date	09-Dec-2007
Causal Part Prefix- Base - Suffix	- -	Dealer Code	UNKNOW
Causal Part Name	unknown	Dealer Name	
Non Causal Part Prefix-Base-Suffix		Dealer City	
Non Causal Part Numbers		Dealer State/Province	
Fault Code		Dealer Country	USA
Diagonstic Trouble Code		Dealer Phone Number	
Labor Operation Code		Attachment	
Communication Type		VOQ Component Description Code	
Maintenance Date	09-Dec-2007		

Customer Comment	CST STS THROTTLE IS STICKING DURING COLD WEATHER,CST STS USUALLY EXPERIENCES PEDAL STICKING WHEN VISITING HIS SISTER IN APPLE VALLEY,STS SINCE IT HAS BEEN RAINING,HAS BEEN EXPERIENCING PEDAL STICKING AT HOME AREA.STS ATTEMPT TO GET ISSUE ADDRESS PREVIOUSLY,BUT LONG BEACH MAZDA WOULD NOT START VEH UNTIL WEATHER WAS WARMER		
Technician Comment	CAC AGENT ADVS VEH NEEDS TO BE DIAGNOSED AT A DEALER,ADVS THAT CAN TAKE VEH TO A DIFFERENT DLR OTHER THAN LONG BEACH MAZDA 0012007 12 07CRPP121 REQ DESC THROTTLE STICKING 0022007 12 08CRPP121 CAC AGENT ADVS VEH NEEDS TO BE DIAGNOSED AT A DEALER,ADVS THAT CAN TAKE VEH TO A DIFFERENT DLR OTHER THAN LONG BEACH MAZDA		
CQIS Recommendations			

Tire Information			
Tire Manufacturer	Unknown	Tire Size	Unknown
Tire Brand Series		Wheel	
DOT Left Front		DOT Right Front	
DOT Left Rear		DOT Right Rear	
DOT Left Inner		DOT Right Inner	
DOT Spare			

Vehicle Information			
VIN	4F2YZ02Z35K	Engine Serial Number	
Model Year	2005	Engine Description	2.3L DOHC EGI I4 16V NA GAS
Transmission	5 SPD MAN TRANS MAZDA M5	Vehicle Description	TRIBUTE
Body Cab Style	CA WE 5 DOOR LIGHT TRUCK	Drive Line	2 WHL L/H FRONT DRIVE
Production Date	08-Dec-2004	Retail Sale Indicator Code	
Plant Description	KANSAS CITY PLANT BUILD	Reaquired Vehicle	
Build Region		Warranty Start Date	04-Apr-2005
Build Country Code		Transmission Serial Number	
Mileage	37000	Vehicle Axle Ratio	
Vehicle Restraint Code			

Disclaimer:

This data is for use as one of several potential "awareness" indicators for the Ford Motor Co. Enhanced Concern Identification System. It is unverified, draft, summary data generated from a computer "word search" of customer and technician symptom comments. Supplier data, technician and customer comments are unverified and actual root cause of any potential issue is not established by this summary.

[Contact ODRHELP](#)

Copyright 2001 Ford Motor Co All Rights Reserved

PE12-019

Mazda

9-6-2012

REQUEST NUMBER THREE
DOCUMENTS (SUBJECT)

Consumer Reports

Mazda CAC

ECI

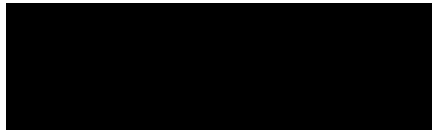



Concern Driven Reporting

Report Detail

Note: Field which are grayed (ghosted) are currently being mapped to the data warehouse. They are not presently being populated.

ECI Record		Source Code	MAZDA CAC
------------	--	-------------	-----------

Commodity Assignment

Commodity	powertrain-engine—	Symptom	no keyword found
Commodity	powertrain-engine-accel pedal/linkage/controls—	Symptom	function-malfunction/inoperative
Commodity	powertrain-engine-accel pedal/linkage/controls—	Symptom	pedal concerns-accelerator pedal
Commodity	powertrain-engine-accel pedal/linkage/controls—	Symptom	sticks/binds/grabs
Significant Event		Verified	N

Tread Information

Reported in Tread Quarter	Q4 2007
---------------------------	---------

Report Details

Source Claim Key		Warranty Component Classification (WCC)	
Corporate Product Systems Classification (CPS)		Time in Service	33
Customer Condition Code		V Function Group (VFG)	
Source System Program Type		Repair/Report/Paid Date	26-Dec-2007
Version Series Code	AAAGH	Load Date	30-Dec-2007
Causal Part Prefix- Base - Suffix	- -	Dealer Code	UNKNOW
Causal Part Name	unknown	Dealer Name	
Non Causal Part Prefix-Base-Suffix		Dealer City	
Non Causal Part Numbers		Dealer State/Province	
Fault Code		Dealer Country	USA
Diagnostic Trouble Code		Dealer Phone Number	
Labor Operation Code		Attachment	
Communication Type		VOQ Component Description Code	
Maintenance Date	30-Dec-2007		

Customer Comment	CUST STS THE GAS PEDAL STICKS. CUST STS SHE CALLED THE DLR AND WAS ADVISED A DIAG FEE WILL BE CHARGED. CUST STS SHE READ ON THE INTERNET THAT THIS IS A COMMON ISSUE WITH THE TRIBUTE.
Technician Comment	FILE CLOSED. 0012007 12 26CRPP229 REQ DESC GAS PEDAL STICKS CUST WAS ADVISED A DIAG FEE MAY BE CHARGED UNTIL THE DLR IS ABLE TO DETERMINE THAT THE REPAIR NEEDED IS WARRANTABLE. CUST WAS ADVISED HER CONCERNS HAVE BEEN DOCUMENTED AND THE REPAIR WILL BE COVERED IF THE DLR IS ABLE TO DUPLICATE THE ISSUE AND DETERMINE THE REPAIR IS WARRANTABLE. CUST UNDERSTOOD AND THANKED, CALL ENDED. FILE CLOSED.
CQIS Recommendations	

Tire Information

Tire Manufacturer	Unknown	Tire Size	Unknown
Tire Brand Series		Wheel	
DOT Left Front		DOT Right Front	
DOT Left Rear		DOT Right Rear	
DOT Left Inner		DOT Right Inner	
DOT Spare			

Vehicle Information

VIN	4F2YZ92Z35K	Engine Serial Number	
Model Year	2005	Engine Description	2.3L DOHC EGI I4 16V NA GAS
Transmission	5 SPD MAN TRANS MAZDA M5	Vehicle Description	TRIBUTE
Body Cab Style	CA WE 5 DOOR LIGHT TRUCK	Drive Line	4 WHL L/H PART TIME DRIVE
Production Date	13-Jan-2005	Retail Sale Indicator Code	
Plant Description	KANSAS CITY PLANT BUILD	Required Vehicle	
Build Region		Warranty Start Date	20-Apr-2005
Build Country Code		Transmission Serial Number	
Mileage	30000	Vehicle Axle Ratio	
Vehicle Restraint Code			

Disclaimer:

This data is for use as one of several potential "awareness" indicators for the Ford Motor Co. Enhanced Concern Identification System. It is unverified, draft, summary data generated from a computer "word search" of customer and technician symptom comments. Supplier data, technician and customer comments are unverified and actual root cause of any potential issue is not established by this summary.

[Contact ODRHELP](#)

Copyright 2001 Ford Motor Co All Rights Reserved

PE12-019

Mazda

9-6-2012

REQUEST NUMBER THREE
DOCUMENTS (SUBJECT)

Consumer Reports

Mazda CAC

ECI

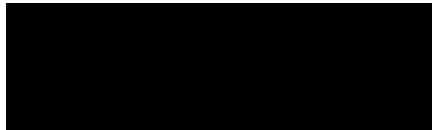



Concern Driven Reporting

Report Detail

Note: Field which are grayed (ghosted) are currently being mapped to the data warehouse. They are not presently being populated.

ECI Record		Source Code	MAZDA CAC
------------	--	-------------	-----------

Commodity Assignment			
Commodity	powertrain-engine	Symptom	field service action
Commodity	powertrain-engine-accel pedal/linkage/controls	Symptom	field service action
Commodity	powertrain-engine-accel pedal/linkage/controls	Symptom	pedal concerns-accelerator pedal
Commodity	powertrain-engine-accel pedal/linkage/controls	Symptom	sticks/binds/grabs
Significant Event		Verified	N

Tread Information	
Reported in Tread Quarter	Q1 2008

Report Details			
Source Claim Key		Warranty Component Classification (WCC)	
Corporate Product Systems Classification (CPSC)		Time in Service	44
Customer Condition Code		V Function Group (VFG)	
Source System Program Type		Repair/Report/Paid Date	22-Feb-2008
Version Series Code	AAAGH	Load Date	24-Feb-2008
Causal Part Prefix-Base-Suffix	-	Dealer Code	UNKNOW
Causal Part Name	unknown	Dealer Name	
Non Causal Part Prefix-Base-Suffix		Dealer City	
Non Causal Part Numbers		Dealer State/Province	
Fault Code		Dealer Country	USA
Diagnostic Trouble Code		Dealer Phone Number	
Labor Operation Code		Attachment	
Communication Type		VOQ Component Description Code	
Maintenance Date	24-Feb-2008		

Customer Comment	CUST STS THAT SHE HAS BEEN IN A DANGEROUS SITUATION WHERE HER THROTTLE CABLE WILL STICK. SEEKS TO KNOW IF THERE ARE ANY RECALLS AND WILL SHE HAVE TO PAY FOR THE REPAIR.
Technician Comment	CAS REVIEWED AND ADV CUST SHE IS NOT INVOLVED IN ANY RECALLS. ADV CUST SHE WILL NEED TO HAVE DIAGD AT DLRSH AND VEH DOES HAVE WTTY LEFT. CUST THANKED. 0012008 02 22CRPP254 REQ DESC THROTTLE CABLE STICKING CAS REVIEWED AND ADV CUST SHE IS NOT INVOLVED IN ANY RECALLS. ADV CUST SHE WILL NEED TO HAVE DIAGD AT DLRSH AND VEH DOES HAVE WTTY LEFT. CUST THANKED.
CQIS Recommendations	

Tire Information			
Tire Manufacturer	Unknown	Tire Size	Unknown
Tire Brand Series		Wheel	
DOT Left Front		DOT Right Front	
DOT Left Rear		DOT Right Rear	
DOT Left Inner		DOT Right Inner	
DOT Spare			

Vehicle Information			
VIN	4F2YZ02Z05K	Engine Serial Number	
Model Year	2005	Engine Description	2.3L DOHC EGI I4 16V NA GAS
Transmission	4 SPD AUTO TRANS MAZDA CD4E	Vehicle Description	TRIBUTE
Body Cab Style	CA WE 5 DOOR LIGHT TRUCK	Drive Line	2 WHL L/H FRONT DRIVE
Production Date	26-May-2004	Retail Sale Indicator Code	
Plant Description	KANSAS CITY PLANT BUILD	Required Vehicle	
Build Region		Warranty Start Date	30-Jul-2004
Build Country Code		Transmission Serial Number	
Mileage	30000	Vehicle Axle Ratio	
Vehicle Restraint Code			

Disclaimer:

This data is for use as one of several potential "awareness" indicators for the Ford Motor Co. Enhanced Concern Identification System. It is unverified, draft, summary data generated from a computer "word search" of customer and technician symptom comments. Supplier data, technician and customer comments are unverified and actual root cause of any potential issue is not established by this summary.

[Contact ODRHELP](#)

Copyright 2001 Ford Motor Co All Rights Reserved

PE12-019

Mazda

9-6-2012

REQUEST NUMBER THREE
DOCUMENTS (SUBJECT)

Consumer Reports

Mazda CAC

ECI

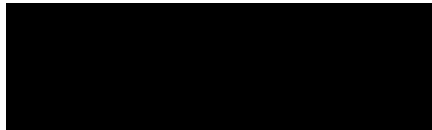



Concern Driven Reporting

Report Detail

Note: Field which are grayed (ghosted) are currently being mapped to the data warehouse. They are not presently being populated.

ECI Record		Source Code	MAZDA CAC
------------	--	-------------	-----------

Commodity Assignment			
Commodity	powertrain-engine—	Symptom	no keyword found
Commodity	powertrain-engine-accel pedal/linkage/controls—	Symptom	frozen/seized
Commodity	powertrain-engine-accel pedal/linkage/controls—	Symptom	function-malfunction/inoperative
Commodity	powertrain-engine-accel pedal/linkage/controls—	Symptom	leak-water leak/entry
Commodity	powertrain-engine-accel pedal/linkage/controls—	Symptom	pedal concerns-accelerator pedal
Commodity	powertrain-engine-accel pedal/linkage/controls—	Symptom	sticks/binds/grabs
Commodity	powertrain-engine-air induction-throttle body-	Symptom	function-malfunction/inoperative
Commodity	powertrain-engine-air induction-throttle body-	Symptom	leak-water leak/entry
Commodity	powertrain-engine-emissions-pcv system-	Symptom	function-malfunction/inoperative
Commodity	powertrain-engine-miscellaneous controls—	Symptom	function-malfunction/inoperative
Commodity	powertrain-engine-miscellaneous controls—	Symptom	leak-water leak/entry
Significant Event		Verified	N

Tread Information	
Reported in Tread Quarter	Q1 2008

Report Details			
Source Claim Key		Warranty Component Classification (WCC)	
Corporate Product Systems Classification (CPS)		Time in Service	49
Customer Condition Code		V Function Group (VFG)	
Source System Program Type		Repair/Report/Paid Date	13-Mar-2008
Version Series Code	AAAQK	Load Date	30-Mar-2008
Causal Part Prefix-Base-Suffix	-	Dealer Code	60326
Causal Part Name	unknown	Dealer Name	HALBINSEL MAZDA
Non Causal Part Prefix-Base-Suffix		Dealer City	ESCANABA
Non Causal Part Numbers		Dealer State/Province	MI
Fault Code		Dealer Country	USA
Diagnostic Trouble Code		Dealer Phone Number	
Labor Operation Code		Attachment	
Communication Type		VOQ Component Description Code	
Maintenance Date	30-Mar-2008		

Customer Comment CST, [REDACTED] STS THE GAS PEDAL WILL STICK CAUSING VEH NOT TO BE ABLE TO BRAKE. CST STS VEH HAS BEEN BACK & FORTH TO THE DLRSHF FOR A MONTH NOW. CST STS DLRSHF IS NOW WAITING ON MAZDA TO FIX THE PROBLEM AND DLRSHF DOESN'T KNOW WHAT TO DO. CST STS HE DOESN'T WANT THE VEH ANY MORE AS IT ISN'T A SAFE VEH. [REDACTED] CELLHM [REDACTED]

Technician Comment TT DLRSHF WHO STS VEH HAS BEEN REPAIRED AND CST IS PICKING VEH UP TODAY. 0012008 03 13CRPP206 REQ DESC GAS PEDAL STICKING TT DAN @ DLRSHF WHO STS VEH CAME IN FOR THROTTLE SYSTEM FREEZING UP ON 1/28 AND LEFT AGAIN ON 1/30. DAN STS VEH CAME BACK IN ON 1/31 AND LEFT ON 2/5 AND RETURNED AGAIN ON 3 1 AND IS STILL AT THE DLRSHF. DAN STS HE IS WAITING ON THE TECH HOTLING TO ADVISE OF A RESOLUTION AND THE DCSM HAS ASKED TO KEEP HIM IN THE LOOP. DAN STS VEH IS NOT SAFE TO DRIVE. TT DCSM, ADAM SWANSON, WHO STS THE BEST REGIONAL SPECIALISTS ARE WORKING ON THE VEH. ADAM STS HE WILL TOUCH BASES WITH TH 0022008 03 13CRPP206 E DOM AND THE SPECIALISTS TO SEE WHAT IS HAPPENING WITH THIS VEH AND GIVE ME A C/B. 0032008 03 17CRPC775 CST STS WOULD LIKE TO SPEAK WITH AGENT. WITH AGENT'S OKAY SENT THE CALL OVER, THANKED. 0042008 03 17CRPP206 CST C/B AND STS RENTAL IS A GAS HOG AND WHAT IS HAPPENING WITH HER VEH. ADV CST I WILL CONTACT THE DLR/DCSM TO SEE WHAT I CAN FIND OUT REGARDING THE STATUS OF HER REPAIR. CALLED DLRSHF, BUT SVC DEPT HAD ALREADY CLOSED. E MAIL TO DCSM, ADAM SWANSON ADAM, DO YOU HAVE ANY UPDATE ON THE REPAIR BEING DONE AT HALBINSEL MAZDA TO THE 2004 TRIBUTE WITH THE GAS PEDAL STICKING THANKS, 0052008 03 18CRPP206 E MAIL FROM DCSM, ADAM SWANSON WE ARE STILL WORKING THIS OUT, THE DEALER DID DUPLICATE THEIR SYMPTOM PRIOR BUT THEY CANNOT ANY MORE DUE TO THE INCREASE IN TEMPERATURE OUTSIDE. I WILL BE CONTACTING THE TECHNICAL OPERATIONS MANAGER TODAY AND WE ARE ACTIVELY TRYING TO MAKE THE APPROPRIATE DECISION/REPAIR. I WOULD HOLD OFF UPDATING THE CUSTOMER ON OUR SITUATION UNTIL I CAN HAVE SOME SOLID ANSWERS FOR YOU. IF YOU HAVE FURTHER QUESTIONS JUST CALL ME THANKS. 0062008 03 19CRPP206 E MAIL FROM DCSM, ADAM SWANSON GLYNN, WE ARE GOING TO REPLACE THE PCV VALVE ON THIS CAR AS WE BELIEVE THIS IS THE MOST LIKELY SOURCE OF THE MOISTURE THAT IS ACCUMULATING ON THE THROTTLE BODY. AFTER THIS REPAIR IS COMPLETED THE CUSTOMER SHOULD PICK UP THEIR VEHICLE. I HAVE AUTHORIZED CSO OVERNIGHT SHIPPING ON THE PART SO THE CAR WILL HOPEFULLY BE REPAIRED BEFORE THE END OF THE WEEK. IF YOU HAVE FURTHER QUESTIONS PLEASE LET ME KNOW. THANKS. 0072008 03 27CRPP206 TT DLRSHF WHO STS VEH HAS BEEN REPAIRED AND CST IS PICKING VEH UP TODAY.

CQIS Recommendations	
----------------------	--

Tire Information			
Tire Manufacturer	Unknown	Tire Size	Unknown
Tire Brand Series		Wheel	
DOT Left Front		DOT Right Front	
DOT Left Rear		DOT Right Rear	
DOT Left Inner		DOT Right Inner	

DOT Spare			
Vehicle Information			
VIN	4F2CZ96134K [REDACTED]	Engine Serial Number	203187658086
Model Year	2004	Engine Description	3.0L DOHC EGI V6 NA*G DSP2967
Transmission	4 SPD AUTO TRANS MAZDA CD4E	Vehicle Description	TRIBUTE
Body Cab Style	CA WE 5 DOOR LIGHT TRUCK	Drive Line	4 WHL L/H PART TIME DRIVE
Production Date	11-Dec-2003	Retail Sale Indicator Code	
Plant Description	KANSAS CITY PLANT BUILD	Reaquired Vehicle	
Build Region		Warranty Start Date	19-Mar-2004
Build Country Code		Transmission Serial Number	
Mileage	0	Vehicle Axle Ratio	
Vehicle Restraint Code			

Disclaimer:

This data is for use as one of several potential "awareness" indicators for the Ford Motor Co. Enhanced Concern Identification System. It is unverified, draft, summary data generated from a computer "word search" of customer and technician symptom comments. Supplier data, technician and customer comments are unverified and actual root cause of any potential issue is not established by this summary.

[Contact CDR HELP](#)
 Copyright 2001 Ford Motor Co. All Rights Reserved

PE12-019

Mazda

9-6-2012

REQUEST NUMBER THREE
DOCUMENTS (SUBJECT)

Consumer Reports

Mazda CAC

ECI

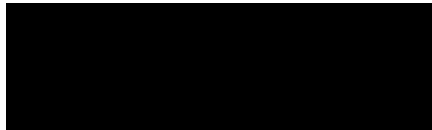



Concern Driven Reporting

Report Detail

Note: Field which are grayed (ghosted) are currently being mapped to the data warehouse. They are not presently being populated.

ECI Record		Source Code	MAZDA CAC
------------	--	-------------	-----------

Commodity Assignment			
Commodity	powertrain-engine—	Symptom	mod-intermittent/random
Commodity	powertrain-engine-accel pedal/linkage/controls—	Symptom	engine power-hesitates
Commodity	powertrain-engine-accel pedal/linkage/controls—	Symptom	function-malfunction/inoperative
Commodity	powertrain-engine-accel pedal/linkage/controls—	Symptom	mod-intermittent/random
Commodity	powertrain-engine-accel pedal/linkage/controls—	Symptom	no problem found
Commodity	powertrain-engine-accel pedal/linkage/controls—	Symptom	pedal concerns-accelerator pedal
Commodity	powertrain-engine-accel pedal/linkage/controls—	Symptom	sticks/binds/grabs
Significant Event		Verified	N

Tread Information	
Reported in Tread Quarter	Q2 2008

Report Details			
Source Claim Key		Warranty Component Classification (WCC)	
Corporate Product Systems Classification (CPSC)		Time in Service	39
Customer Condition Code		V Function Group (VFG)	
Source System Program Type		Repair/Report/Paid Date	07-Apr-2008
Version Series Code	AAAGH	Load Date	14-Apr-2008
Causal Part Prefix-Base-Suffix	-	Dealer Code	42004
Causal Part Name	unknown	Dealer Name	OAK TREE MAZDA
Non Causal Part Prefix-Base-Suffix		Dealer City	SAN JOSE
Non Causal Part Numbers		Dealer State/Province	CA
Fault Code		Dealer Country	USA
Diagnostic Trouble Code		Dealer Phone Number	4085536300
Labor Operation Code		Attachment	
Communication Type		VOQ Component Description Code	
Maintenance Date	14-Apr-2008		

Customer Comment	CST STD BROUGHT VEH TO DLR FOR SERVICE AND ADV DLR INTERMITTEN ISSUE THAT HAPPENS AT MOST, ONCE A WEEK WHEN ACCELERATING VEH, PEDAL WILL STICK FOR A SECOND OR TWO AND THEN ALLOW HER TO ACCELERATE. STD THAT DLR ADV UNABLE TO DIAG IF UNABLE TO DUPLICATE PROBLEM. STD DLR ADV TO KEEP TRACK OF WHEN HAPPENS TO VEH SO DLE CVAN HAVE A BETTER IDEA OF HOW TO DUPLICATE. CST INQ IF ANY OTHER INFO AVAILABLE FROM MNAO.
Technician Comment	CAS ADV CST THAT NOT TECH TRAINED AT THIS OFFICE. ADV CST THAT DLR IS CORRECT, WOULD NEED TO DUPLICATE TO DIAG AND REPAIR. ADV CST I WOULD RECOMMEND KEEPING TRACK OF WHEN HAPPENS SO DLR HAS BETTER CHANCES OF DUPLICATING. CST STD UNDERSTANDS AND WILL KEEP TRACK OF INTERMITTEN ISSUE AND SCH APPT WITH DLR LATER. CAD INQ IF ANY FURTHER ASSISTANCE NEEDED AND CST STD NOTHING ELSE NEEDED. CST THANKED. 0012008 04 07CRPC/777 REQ DESC TECH QUESTION/GAS PEDAL HESITATION CAS ADV CST THAT NOT TECH TRAINED AT THIS OFFICE. ADV CST THAT DLR IS CORRECT, WOULD NEED TO DUPLICATE TO DIAG AND REPAIR. ADV CST I WOULD RECOMMEND KEEPING TRACK OF WHEN HAPPENS SO DLR HAS BETTER CHANCES OF DUPLICATING. CST STD UNDERSTANDS AND WILL KEEP TRACK OF INTERMITTEN ISSUE AND SCH APPT WITH DLR LATER. CAD INQ IF ANY FURTHER ASSISTANCE NEEDED AND CST STD NOTHING ELSE NEEDED. CST THANKED.
CQIS Recommendations	

Tire Information			
Tire Manufacturer	Unknown	Tire Size	Unknown
Tire Brand Series		Wheel	
DOT Left Front		DOT Right Front	
DOT Left Rear		DOT Right Rear	
DOT Left Inner		DOT Right Inner	
DOT Spare			

Vehicle Information			
VIN	4F2YZ02Z95K	Engine Serial Number	
Model Year	2005	Engine Description	2.3L DOHC EGI I4 16V NA GAS
Transmission	4 SPD AUTO TRANS MAZDA CD4E	Vehicle Description	TRIBUTE
Body Cab Style	CA WE 5 DOOR LIGHT TRUCK	Drive Line	2 WHL L/H FRONT DRIVE
Production Date	28-Jan-2005	Retail Sale Indicator Code	
Plant Description	KANSAS CITY PLANT BUILD	Required Vehicle	
Build Region		Warranty Start Date	19-Feb-2005
Build Country Code		Transmission Serial Number	
Mileage	36000	Vehicle Axle Ratio	
Vehicle Restraint Code			

Disclaimer:

This data is for use as one of several potential "awareness" indicators for the Ford Motor Co. Enhanced Concern Identification System. It is unverified, draft, summary data generated from a computer "word search" of customer and technician symptom comments. Supplier data, technician and customer comments are unverified and actual root cause of any potential issue is not established by this summary.

[Contact ODRHELP](#)

Copyright 2001 Ford Motor Co All Rights Reserved

PE12-019

Mazda

9-6-2012

REQUEST NUMBER THREE
DOCUMENTS (SUBJECT)

Consumer Reports

Mazda CAC

ECI

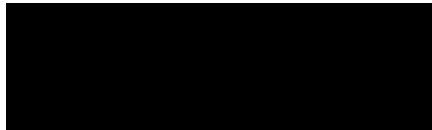



Concern Driven Reporting

Report Detail

Note: Field which are grayed (ghosted) are currently being mapped to the data warehouse. They are not presently being populated.

ECI Record		Source Code	MAZDA CAC
------------	--	-------------	-----------

Commodity Assignment

Commodity	powertrain-engine	Symptom	circuit-poor contact/poor ground
Commodity	powertrain-engine-accel pedal/linkage/controls	Symptom	administrative cost
Commodity	powertrain-engine-accel pedal/linkage/controls	Symptom	pedal concerns-accelerator pedal
Commodity	powertrain-engine-accel pedal/linkage/controls	Symptom	sticks/binds/grabs
Significant Event		Verified	N

Tread Information

Reported in Tread Quarter	Q2 2008
---------------------------	---------

Report Details

Source Claim Key		Warranty Component Classification (WCC)	
Corporate Product Systems Classification (CPSC)		Time in Service	9
Customer Condition Code		V Function Group (VFG)	
Source System Program Type		Repair/Report/Paid Date	10-Jun-2008
Version Series Code	AAAGH	Load Date	06-Jul-2008
Causal Part Prefix- Base - Suffix	-	Dealer Code	50514
Causal Part Name	unknown	Dealer Name	DUNCAN MAZDA
Non Causal Part Prefix-Base-Suffix		Dealer City	BLACKSBURG
Non Causal Part Numbers		Dealer State/Province	VA
Fault Code		Dealer Country	USA
Diagonstic Trouble Code		Dealer Phone Number	
Labor Operation Code		Attachment	
Communication Type		VOQ Component Description Code	
Maintenance Date	07-Oct-2008		

Customer Comment
CST STS DLR COULDN'T PROVIDE A RENTAL AND WOULD LIKE TO KNOW IF A RENTAL COULD BE PROVIDED IF THE VEH ISN'T FIXED. STS THE GAS PEDAL STICKS AND VEH KEEPS GOING. STS UNHAPPY HIS SELLING DLR COULDN'T SOLVE THE ISSUE IN THREE ATTEMPTS BUT DLR 50514 WAS ABLE TO. STS WOULD LIKE TO KNOW WHAT COULD BE DONE TO GET HIM A LOANER IF VEH IS NOT READY TONIGHT.

Technician Comment
CST HAS NOT CONTACT CAC SINCE 06/10/2008 INREGARDS TO THIS ISSUE. IF CST CALLS INTO THE CAC INREGARDS TO THIS CONCERN PLEASE REVEIW AND ASSIST ACCORDINGLY. 0012008 06 10CRPP177 REQ DESC DOC CONCERNS W/RENTAL AND GAS PEDAL ISSUES CAS ADV'D IF VEH IS NOT READY AND CST NEEDS A RENTAL PROVIDED I WOULD REVIEW FOR POSSIBLE ASSIST. ADV'D VDN AND FOR CST TO CALL BACK @ THAT TIME.. 0022008 09 29CRPP187 CST HAS NOT CONTACT CAC SINCE 06/10/2008 INREGARDS TO THIS ISSUE. IF CST CALLS INTO THE CAC INREGARDS TO THIS CONCERN PLEASE REVEIW AND ASSIST ACCORDINGLY.

CQIS Recommendations

Tire Information

Tire Manufacturer	Unknown	Tire Size	Unknown
Tire Brand Series		Wheel	
DOT Left Front		DOT Right Front	
DOT Left Rear		DOT Right Rear	
DOT Left Inner		DOT Right Inner	
DOT Spare			

Vehicle Information

VIN	4F2CZ02Z88K	Engine Serial Number	300707033352
Model Year	2008	Engine Description	2.3L 4V DOHC EFI NA I4 GAS
Transmission	5 SPD MAN TRANS AKK	Vehicle Description	TRIBUTE
Body Cab Style	CA WE 5 DOOR LIGHT TRUCK	Drive Line	2 WHL L/H FRONT DRIVE
Production Date	31-Aug-2007	Retail Sale Indicator Code	
Plant Description	KANSAS CITY PLANT BUILD	Reaquired Vehicle	
Build Region		Warranty Start Date	12-Oct-2007
Build Country Code		Transmission Serial Number	
Mileage	0	Vehicle Axle Ratio	
Vehicle Restraint Code			

Disclaimer:

This data is for use as one of several potential "awareness" indicators for the Ford Motor Co. Enhanced Concern Identification System. It is unverified, draft, summary data generated from a computer "word search" of customer and technician symptom comments. Supplier data, technician and customer comments are unverified and actual root cause of any potential issue is not established by this summary.

[Contact ODRHELP](#)

Copyright 2001 Ford Motor Co All Rights Reserved

PE12-019

Mazda

9-6-2012

REQUEST NUMBER THREE
DOCUMENTS (SUBJECT)

Consumer Reports

Mazda CAC

ECI

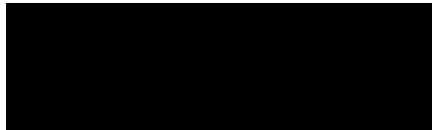



Concern Driven Reporting

Report Detail

Note: Field which are grayed (ghosted) are currently being mapped to the data warehouse. They are not presently being populated.

ECI Record		Source Code	MAZDA CAC
------------	--	-------------	-----------

Commodity Assignment			
Commodity	powertrain-engine	Symptom	damage-cracked/fractured/split
Commodity	powertrain-engine	Symptom	field service action
Commodity	powertrain-engine	Symptom	function-malfunction/inoperative
Commodity	powertrain-engine	Symptom	mod-driving condition-while driving
Commodity	powertrain-engine	Symptom	no keyword found
Commodity	powertrain-engine	Symptom	pedal concerns-accelerator pedal
Commodity	powertrain-engine	Symptom	separation
Commodity	powertrain-engine-accel pedal/linkage/controls	Symptom	function-malfunction/inoperative
Commodity	powertrain-engine-accel pedal/linkage/controls	Symptom	mod-driving condition-while driving
Commodity	powertrain-engine-accel pedal/linkage/controls	Symptom	mod-vehicle towed in
Commodity	powertrain-engine-accel pedal/linkage/controls	Symptom	pedal concerns-accelerator pedal
Commodity	powertrain-engine-accel pedal/linkage/controls	Symptom	separation
Significant Event		Verified	N

Tread Information	
Reported in Tread Quarter	Q3 2008

Report Details			
Source Claim Key		Warranty Component Classification (WCC)	
Corporate Product Systems Classification (CPSC)		Time in Service	48
Customer Condition Code		V Function Group (VFG)	
Source System Program Type		Repair/Report/Paid Date	09-Jul-2008
Version Series Code	AAAQK	Load Date	13-Jul-2008
Causal Part Prefix - Base - Suffix	- -	Dealer Code	34611
Causal Part Name	unknown	Dealer Name	WYATT JOHNSON MAZDA
Non Causal Part Prefix-Base-Suffix		Dealer City	CLARKSVILLE
Non Causal Part Numbers		Dealer State/Province	TN
Fault Code		Dealer Country	USA
Diagnostic Trouble Code		Dealer Phone Number	9316484300
Labor Operation Code		Attachment	
Communication Type		VOQ Component Description Code	
Maintenance Date	13-Jul-2008		

Customer Comment CST STS VEH THROTTLE CABLE BROKE OFF AND THE GAS PEDAL WENT TO THE FLOOR. ADV THAT VEH IS ON THE SIDE OF THE ROAD AWAITING A TOW. ADV THAT VEH IS BEING TOWED TO DLR FOR INSPECTION. STS VEH ONLY HAS 59K MILES AND SHOULD NOT HAVE THIS ISSUE. STS AC SYSTEM IS NOT FUNCTIONING PROPERLY AND WAS REPAIRED UNDER NVLW. STS AC SHOULD BE REPAIRED AGAIN AUTOMATICALLY AS IT WAS A PRIOR ISSUE. STS VEH IS OOW WITH 59KMILES.

Technician Comment CONTACTED CST ADV OF CONVERSATION WITH SVM. ADV THAT RECALL HAD BEEN PERFORMED AND CLOSED AS OF 2005. ADV THAT ONCE A RECALL IS REPAIRED ISSUE IS CONSIDERED RESOLVED. ADV THAT VEH IS 9K MILES OOW. ADV THAT DUE TO VEH MILEAGE AND PRIOR RECALL I HAD MADE THE GW DECISION TO AUTHORIZE REPLACEMENT OF THROTTLE CABLE. ADV CST THAT AC ISSUE IS COMPLETELY SEPERATE ISSUE AND SINCE DLR WAS NOT AUTHORIZED TO INSPECT I COULD NOT REVIEW THIS. ADV THAT CST WOULD INCCUR AN INITIAL DIAG 0012008 07 09CRPC763 REQ DESC THROTTLE CABLE ADV CST THAT VEH IS OOW WRITTY BY TIME. ADV THAT REGARDLESS OF PAST ISSUES W/VEH ONCE A VEH IS OOW REPAIRS ARE CST RESPONSIBILITY. ADV CST OF AWA BASICS AND TO CONTACT ME WHEN VEH IS AT DLR FOR INSPECTION. ADV CST VDN AND FILE#. [REDACTED] 07 09CRPP256 CUSTOMER CALLED INFORMED STEVE, WAS ON ANOTHER LINE. CUSTOMER STATES VEH IS AT WYATT MAZDA. WOULD LIKE A CALL BACK AT [REDACTED] (MOBILE) INFORMED CUSTOMER STEVE WOULD FOLLOW UP ONCE HE SPEAKS WITH DEALER SERVICE. 0032008 07 10CRPC763 CONTACTED SVM WAYNE AT DLR. ADV THAT VEH HAS 59K MILES AND NEEDS A THROTTLE CABLE. ADV THAT CABLE BROKE OFF FROM BACK OF PEDAL. ADV THAT AS OF 7/9/07 AC HOSE WAS DONE UNDER WRITTY AND CUSTOMER PAY FOR BRAKE. ADV THAT AS OF A 10K SERVICE WAS DONE AND MOST RECENTLY AS OF 1/08 AN OIL SERVICE WAS DONE. ADV THAT VEH HAS NOT BEEN INSPECTED FOR AN AC ISSUE AS THE CST DID NOT ADV DLR TO INSPECT. ADV SVM THAT I WOULD AUTH REPLACEMENT OF THROTTLE CABLE AT \$175.54 AS IT HAD ALREADY BEEN ADDRESSED BY A RECALL, CST HAD A 10K SERVICE, BRAKE SE 0042008 07 10CRPC763 RVICE AND 2 ADDITIONAL OIL SERVICES. ADV SVM OF AUTH # LEFT V/M FOR CST C/B. 0052008 07 10CRPP206 CST C/B AND STS DLRSPH IS WAITING ON AN ANS. CST STS HE DOESN'T THINK HE SHOULD HAVE TO PAY FOR THE THROTTLE CABLE. ADV CST STEVE, THE CAS, HE IS WORKING WITH IS ON THE PHONE, BUT HAS ADVISED ME THAT HE WILL GIVE CST A C/B AS SOON AS HE IS OFF THE PHONE. ADV CST I WILL SEND STEVE A MESS THAT CST IS WAITING ON A C/B. SCREEN SHOT TO STEVE 0062008 07 10CRPC763 CONTACTED CST ADV OF CONVERSATION WITH SVM. ADV THAT RECALL HAD BEEN PERFORMED AND CLOSED AS OF 2005. ADV THAT ONCE A RECALL IS REPAIRED ISSUE IS CONSIDERED RESOLVED. ADV THAT VEH IS 9K MILES OOW. ADV THAT DUE TO VEH MILEAGE AND PRIOR RECALL I HAD MADE THE GW DECISION TO AUTHORIZE REPLACEMENT OF THROTTLE CABLE. ADV CST THAT AC ISSUE IS COMPLETELY SEPERATE ISSUE AND SINCE DLR WAS NOT AUTHORIZED TO INSPECT I COULD NOT REVIEW THIS. ADV THAT CST WOULD INCCUR AN INITIAL DIAG FEE FOR POSSIBLE ASSISTANCE. ADV AC ISSUE IS NEW AND SEPER 0072008 07 10CRPC763 ATE. CST THANKED FOR GW ON CABLE AND WILL DECIDED ON AC CONCERN.

CQIS Recommendations

Tire Information

Tire Manufacturer	Unknown	Tire Size	Unknown
Tire Brand Series		Wheel	
DOT Left Front		DOT Right Front	
DOT Left Rear		DOT Right Rear	
DOT Left Inner		DOT Right Inner	
DOT Spare			

Vehicle Information

VIN	4F2CZ06154K	Engine Serial Number	003125379087
Model Year	2004	Engine Description	3.0L DOHC EGI V6 NA*G DSP2967
Transmission	4 SPD AUTO TRANS MAZDA CD4E	Vehicle Description	TRIBUTE
Body Cab Style	CA WE 5 DOOR LIGHT TRUCK	Drive Line	2 WHL L/H FRONT DRIVE
Production Date	28-Oct-2003	Retail Sale Indicator Code	
Plant Description	KANSAS CITY PLANT BUILD	Reaquired Vehicle	
Build Region		Warranty Start Date	31-Jul-2004
Build Country Code		Transmission Serial Number	
Mileage	59000	Vehicle Axle Ratio	
Vehicle Restraint Code			

Disclaimer:

This data is for use as one of several potential "awareness" indicators for the Ford Motor Co. Enhanced Concern Identification System. It is unverified, draft, summary data generated from a computer "word search" of customer and technician symptom comments. Supplier data, technician and customer comments are unverified and actual root cause of any potential issue is not established by this summary.

[Contact CDR HELP](#)

Copyright 2001 Ford Motor Co All Rights Reserved

PE12-019

Mazda

9-6-2012

REQUEST NUMBER THREE
DOCUMENTS (SUBJECT)

Consumer Reports

Mazda CAC

ECI

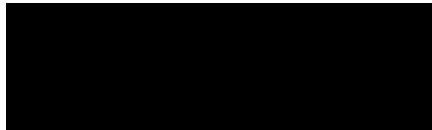



Concern Driven Reporting

Report Detail

Note: Field which are grayed (ghosted) are currently being mapped to the data warehouse. They are not presently being populated.

ECI Record		Source Code	MAZDA CAC
------------	--	-------------	-----------

Commodity Assignment

Commodity	powertrain-engine	Symptom	separation
Commodity	powertrain-engine-accel pedal/linkage/controls	Symptom	loose
Commodity	powertrain-engine-accel pedal/linkage/controls	Symptom	pedal concerns-accelerator pedal
Significant Event		Verified	N

Tread Information

Reported in Tread Quarter	Q3 2008
---------------------------	---------

Report Details

Source Claim Key		Warranty Component Classification (WCC)	
Corporate Product Systems Classification (CPSC)		Time in Service	11
Customer Condition Code		V Function Group (VFG)	
Source System Program Type		Repair/Report/Paid Date	12-Aug-2008
Version Series Code	AAAGH	Load Date	17-Aug-2008
Causal Part Prefix-Base-Suffix	-	Dealer Code	UNKNOW
Causal Part Name	unknown	Dealer Name	
Non Causal Part Prefix-Base-Suffix		Dealer City	
Non Causal Part Numbers		Dealer State/Province	
Fault Code		Dealer Country	USA
Diagonstic Trouble Code		Dealer Phone Number	
Labor Operation Code		Attachment	
Communication Type		VOQ Component Description Code	
Maintenance Date	17-Aug-2008		

Customer Comment	CST STS HE HAD AN ISSUE WHERE THE GAS PEDAL FELL TO THE FLOOR. STS HAD THE VEH TAKEN TO HIS LOCAL DLR AND IT WAS RPR'D. STS THINKS THIS WILL HAPPEN AGAIN AND WANTS OUT OF THE VEH.		
Technician Comment	CAS APOL & INQUIRED TO KNOW IF THE CST ONLY SEEKED TO BE PULLED OUT OF THE VEH. CST STS YES. CAS ADV'D BBB CONTACT INFO. CST THANKED. 0012008 08 12CRPP177 REQ DESC INQ RE BUY BACK CAS APOL & INQUIRED TO KNOW IF THE CST ONLY SEEKED TO BE PULLED OUT OF THE VEH. CST STS YES. CAS ADV'D BBB CONTACT INFO. CST THANKED.		
CQIS Recommendations			

Tire Information

Tire Manufacturer	Unknown	Tire Size	Unknown
Tire Brand Series		Wheel	
DOT Left Front		DOT Right Front	
DOT Left Rear		DOT Right Rear	
DOT Left Inner		DOT Right Inner	
DOT Spare			

Vehicle Information

VIN	4F2CZ02Z58K	Engine Serial Number	300707104355
Model Year	2008	Engine Description	2.3L 4V DOHC EFI NA I4 GAS
Transmission	4 SPD AUTO TRANS NAAO CD4E	Vehicle Description	TRIBUTE
Body Cab Style	CA WE 5 DOOR LIGHT TRUCK	Drive Line	2 WHL L/H FRONT DRIVE
Production Date	10-Aug-2007	Retail Sale Indicator Code	
Plant Description	KANSAS CITY PLANT BUILD	Reaquired Vehicle	
Build Region		Warranty Start Date	06-Oct-2007
Build Country Code		Transmission Serial Number	
Mileage	0	Vehicle Axle Ratio	
Vehicle Restraint Code			

Disclaimer:

This data is for use as one of several potential "awareness" indicators for the Ford Motor Co. Enhanced Concern Identification System. It is unverified, draft, summary data generated from a computer "word search" of customer and technician symptom comments. Supplier data, technician and customer comments are unverified and actual root cause of any potential issue is not established by this summary.

[Contact ODRHELP](#)

Copyright 2001 Ford Motor Co All Rights Reserved

PE12-019

Mazda

9-6-2012

REQUEST NUMBER THREE
DOCUMENTS (SUBJECT)

Consumer Reports

Mazda CAC

eci

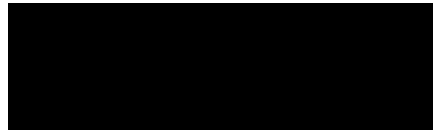



Concern Driven Reporting

Report Detail

Note: Field which are grayed (ghosted) are currently being mapped to the data warehouse. They are not presently being populated.

ECI Record		Source Code	MAZDA CAC
------------	--	-------------	-----------

Commodity Assignment

Commodity	powertrain-engine	Symptom	mod-driving condition-at cruise
Commodity	powertrain-engine	Symptom	no keyword found
Commodity	powertrain-engine	Symptom	pedal concerns-accelerator pedal
Commodity	powertrain-engine	Symptom	sticks/binds/grabs
Commodity	powertrain-engine-accel pedal/linkage/controls	Symptom	sticks/binds/grabs
Significant Event		Verified	N

Tread Information

Reported in Tread Quarter	Q3 2008
---------------------------	---------

Report Details

Source Claim Key		Warranty Component Classification (WCC)	
Corporate Product Systems Classification (CPS)		Time in Service	67
Customer Condition Code		V Function Group (VFG)	
Source System Program Type		Repair/Report/Paid Date	10-Sep-2008
Version Series Code	AAAA5	Load Date	15-Sep-2008
Causal Part Prefix-Base-Suffix	-	Dealer Code	23710
Causal Part Name	unknown	Dealer Name	OCEAN MAZDA
Non Causal Part Prefix-Base-Suffix		Dealer City	MIAMI
Non Causal Part Numbers		Dealer State/Province	FL
Fault Code		Dealer Country	USA
Diagnostic Trouble Code		Dealer Phone Number	/864641100
Labor Operation Code		Attachment	
Communication Type		VOQ Component Description Code	
Maintenance Date	15-Sep-2008		

Customer Comment	RCVD LTR FROM CST, STS WAS DRIVING AT HIGHWAY SPEEDS, STS ACCELERATOR GOT STUCK AND SHE WAS UNABLE TO STOP THE VEHICLE. STS THAT BRAKES WOULD NOT STOP VEH AND IF SHE LET OFF THE BRAKE THE VEH WOULD ACCELERATE. STS EMERGENCY BRAKE WOULDNT STOP VEH. STS LUCKILY DIDNT HAVE VEHs IN FRONT OF HER SO WAS ABLE TO AVOID ACCIDENT. STS HAS HAD ALL MAINT DONE, JUST HAD BRAKES AND TIRES DONE. REQ REIMB FOR REPAIRS AND MAINT DIR ADVD SHOULD BE DONE DUE TO CONCERN.
Technician Comment	SUBMITTED CHECK REQUEST 0012008 09 10CRPC489 REQ DESC THROTTLE STUCK OPEN CLLD CST, APOLOGIZED FOR CONCERN SHE HAD IN VEH. ADVD CAS UNDERSTANDS HOW FRIGHTENED SHE MUST HAVE BEEN. ADVD NOT AWARE OF SIMILAR CONCERNS WITH VEHs. ADV UNDER CIRCUMSTANCES CAS WILL REIMB REPAIR COSTS AND MAINT THAT DLR RECOMMENDED BECAUSE SHE IS ORIG OWNER, DOES MAINT AT THE DEALER AND CAS WANTS TO RESTORE FAITH IN MAZDA BRAND. CST THANKED. ADVD WILL DOC CONCERN FOR QUALITY DEPT IN CORPORATE RECORDS AND TO CALL IF ANY FURTHER CONCERNS ARISE. 0022008 09 10CRPC489 SUBMITTED CHECK REQUEST
CQIS Recommendations	

Tire Information

Tire Manufacturer	Unknown	Tire Size	Unknown
Tire Brand Series		Wheel	
DOT Left Front		DOT Right Front	
DOT Left Rear		DOT Right Rear	
DOT Left Inner		DOT Right Inner	
DOT Spare			

Vehicle Information

VIN	4F2YZ041X3K	Engine Serial Number	
Model Year	2003	Engine Description	3.0L DOHC EGI V6 NA*G DSP296/
Transmission	4 SPD AUTO TRANS MAZDA CD4E	Vehicle Description	TRIBUTE
Body Cab Style	CA WE 5 DOOR LIGHT TRUCK	Drive Line	2 WHL L/H FRONT DRIVE
Production Date	06-Dec-2002	Retail Sale Indicator Code	
Plant Description	KANSAS CITY PLANT BUILD	Required Vehicle	
Build Region		Warranty Start Date	05-Apr-2003
Build Country Code		Transmission Serial Number	
Mileage	82000	Vehicle Axle Ratio	
Vehicle Restraint Code			

Disclaimer:

This data is for use as one of several potential "awareness" indicators for the Ford Motor Co. Enhanced Concern Identification System. It is unverified, draft, summary data generated from a computer "word search" of customer and technician symptom comments. Supplier data, technician and customer comments are unverified and actual root cause of any potential issue is not established by this summary.

[Contact ODRHELP](#)

Copyright 2001 Ford Motor Co All Rights Reserved

PE12-019

Mazda

9-6-2012

REQUEST NUMBER THREE
DOCUMENTS (SUBJECT)

Consumer Reports

Mazda CAC

ECI

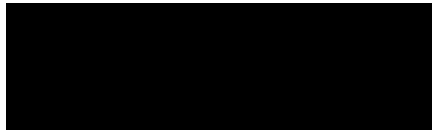



Concern Driven Reporting

Report Detail

Note: Field which are grayed (ghosted) are currently being mapped to the data warehouse. They are not presently being populated.

ECI Record		Source Code	MAZDA CAC
------------	--	-------------	-----------

Commodity Assignment			
Commodity	powertrain-engine—	Symptom	mod-vehicle towed in
Commodity	powertrain-engine-accel pedal/linkage/controls—	Symptom	mod-driving condition-at start up
Commodity	powertrain-engine-accel pedal/linkage/controls—	Symptom	mod-driving condition-engine-cold
Commodity	powertrain-engine-accel pedal/linkage/controls—	Symptom	nvh-noisy operation
Commodity	powertrain-engine-accel pedal/linkage/controls—	Symptom	pedal concerns-accelerator pedal
Commodity	powertrain-engine-accel pedal/linkage/controls—	Symptom	sticks/binds/grabs
Commodity	powertrain-engine-accessory drive-belts-	Symptom	mod-driving condition-at start up
Commodity	powertrain-engine-accessory drive-belts-	Symptom	mod-driving condition-engine-cold
Commodity	powertrain-engine-accessory drive-belts-	Symptom	mod-vehicle towed in
Commodity	powertrain-engine-accessory drive-belts-	Symptom	nvh-noisy operation
Commodity	powertrain-engine-accessory drive-belts-	Symptom	sticks/binds/grabs
Significant Event		Verified	N

Tread Information	
Reported in Tread Quarter	Q4 2008

Report Details			
Source Claim Key		Warranty Component Classification (WCC)	
Corporate Product Systems Classification (CPSC)		Time in Service	
Customer Condition Code		V Function Group (VFG)	
Source System Program Type		Repair/Report/Paid Date	20-Oct-2008
Version Series Code		Load Date	27-Oct-2008
Causal Part Prefix- Base - Suffix	- -	Dealer Code	UNKNOW
Causal Part Name	unknown	Dealer Name	
Non Causal Part Prefix-Base-Suffix		Dealer City	
Non Causal Part Numbers		Dealer State/Province	
Fault Code		Dealer Country	USA
Diagonal Trouble Code		Dealer Phone Number	
Labor Operation Code		Attachment	
Communication Type		VOQ Component Description Code	
Maintenance Date	27-Oct-2008		

Customer Comment	CST STS THAT BELTS ARE NOISY AND THAT THE THROTTLE STICKS WHEN COLD.
Technician Comment	PROVIDED CUST WITH RSA #. ADVISED RSA WILL TOW TO LOCAL DEALER. 0012008 10 20CRPP933 REQ DESC BELTS NOISY PROVIDED CUST WITH RSA #. ADVISED RSA WILL TOW TO LOCAL DEALER.
C Q I S Recommendations	

Tire Information			
Tire Manufacturer	Unknown	Tire Size	Unknown
Tire Brand Series		Wheel	
DOT Left Front		DOT Right Front	
DOT Left Rear		DOT Right Rear	
DOT Left Inner		DOT Right Inner	
DOT Spare			

Vehicle Information			
VIN	4F2CZ02Z68K	Engine Serial Number	301007221310
Model Year	2008	Engine Description	2.3L 4V DOHC EFI NA I4 GAS
Transmission	4 SPD AUTO TRANS NAAO CD4E	Vehicle Description	TRIBUTE
Body Cab Style	Unknown	Drive Line	2 WHL L/H FRONT DRIVE
Production Date	09-Nov-2007	Retail Sale Indicator Code	
Plant Description	Unknown	Required Vehicle	
Build Region		Warranty Start Date	
Build Country Code		Transmission Serial Number	
Mileage	0	Vehicle Axle Ratio	
Vehicle Restraint Code			

Disclaimer:

This data is for use as one of several potential "awareness" indicators for the Ford Motor Co. Enhanced Concern Identification System. It is unverified, draft, summary data generated from a computer "word search" of customer and technician symptom comments. Supplier data, technician and customer comments are unverified and actual root cause of any potential issue is not established by this summary.

[Contact ODRHELP](#)

Copyright 2001 Ford Motor Co All Rights Reserved

PE12-019

Mazda

9-6-2012

REQUEST NUMBER THREE
DOCUMENTS (SUBJECT)

Consumer Reports

Mazda CAC

ECI

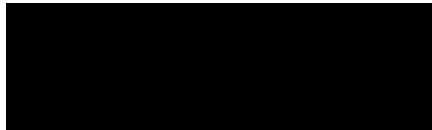



Concern Driven Reporting

Report Detail

Note: Field which are grayed (ghosted) are currently being mapped to the data warehouse. They are not presently being populated.

ECI Record		Source Code	MAZDA CAC
------------	--	-------------	-----------

Commodity Assignment			
Commodity	powertrain-engine—	Symptom	function-malfunction/inoperative
Commodity	powertrain-engine-accel pedal/linkage/controls—	Symptom	frozen/seized
Commodity	powertrain-engine-accel pedal/linkage/controls—	Symptom	mod-driving condition-while driving
Commodity	powertrain-engine-accel pedal/linkage/controls—	Symptom	no keyword found
Commodity	powertrain-engine-accel pedal/linkage/controls—	Symptom	pedal concerns-accelerator pedal
Commodity	powertrain-engine-air induction-throttle body-	Symptom	frozen/seized
Commodity	powertrain-engine-air induction-throttle body-	Symptom	mod-driving condition-while driving
Commodity	powertrain-engine-air induction-throttle body-	Symptom	no keyword found
Significant Event		Verified	N

Tread Information	
Reported in Tread Quarter	Q4 2008

Report Details			
Source Claim Key		Warranty Component Classification (WCC)	
Corporate Product Systems Classification (CPS)		Time in Service	32
Customer Condition Code		V Function Group (VFG)	
Source System Program Type		Repair/Report/Paid Date	21-Oct-2008
Version Series Code	AAAGH	Load Date	27-Oct-2008
Causal Part Prefix-Base-Suffix	-	Dealer Code	34476
Causal Part Name	unknown	Dealer Name	HIXSON AUTO OF ALEX MAZDA
Non Causal Part Prefix-Base-Suffix		Dealer City	ALEXANDRIA
Non Causal Part Numbers		Dealer State/Province	LA
Fault Code		Dealer Country	USA
Diagnostic Trouble Code		Dealer Phone Number	
Labor Operation Code		Attachment	
Communication Type		VOQ Component Description Code	
Maintenance Date	27-Oct-2008		

Customer Comment	CUST STS WHILE DAUGHTER DRIVING GAS PEDAL FROZE. STS NEEDS NEW THROTTLE BODY & DLR. ADVD OUT OF WTTY. CUST REQ AWA.337.298.9207		
Technician Comment	LEFT V/M STATING CAS WAS AWARE THAT DSM WAS @ DLR & APPROVED THE REPAIR. *NO FURTHER ACTION TAKEN* 0012008 10 21CRPP233 REQ DESC THROTTLE BODY/AWA WITH CUST ON HOLD. TT SVC ADVISOR AL WHO STD CUST JUST OUT OF WTTY & NEEDS THROTTLE BODY. ASKED HIM IF HE CLD CONTACT DSM TO AUTHOR. PART & TO CALL CAS BACK WITH DECISION. ADVD CUST WLD CALL HER WITH DSM DECISION. ADVD DSM HIGHEST FORM OF ESCALATION & DECISION IS FINAL. 0022008 10 22CRPP233 TT AL @ DLR WHO STD DSM HAPPENED TO BE THERE YESTERDAY & APPROVED THE REPAIR. STS CUST HAPPY. LEFT V/M STATING CAS WAS AWARE THAT DSM WAS @ DLR & APPROVED THE REPAIR. *NO FURTHER ACTION TAKEN*		
CQIS Recommendation			

Tire Information			
Tire Manufacturer	Unknown	Tire Size	Unknown
Tire Brand Series		Wheel	
DOT Left Front		DOT Right Front	
DOT Left Rear		DOT Right Rear	
DOT Left Inner		DOT Right Inner	
DOT Spare			

Vehicle Information			
VIN	4F2YZ02Z36K	Engine Serial Number	151205150553
Model Year	2006	Engine Description	2.3L DOHC EGI I4 16V NA GAS
Transmission	4 SPD AUTO TRANS MAZDA CD4E	Vehicle Description	TRIBUTE
Body Cab Style	CA WE 3 DOOR LIGHT TRUCK	Drive Line	2 WHL L/H FRONT DRIVE
Production Date	25-Jan-2006	Retail Sale Indicator Code	
Plant Description	KANSAS CITY PLANT BUILD	Reaquired Vehicle	
Build Region		Warranty Start Date	09-Mar-2006
Build Country Code		Transmission Serial Number	
Mileage	50590	Vehicle Axle Ratio	
Vehicle Restraint Code			

Disclaimer:

This data is for use as one of several potential "awareness" indicators for the Ford Motor Co. Enhanced Concern Identification System. It is unverified, draft, summary data generated from a computer "word search" of customer and technician symptom comments. Supplier data, technician and customer comments are unverified and actual root cause of any potential issue is not established by this summary.

[Contact ODRHELP](#)

Copyright 2001 Ford Motor Co All Rights Reserved

PE12-019

Mazda

9-6-2012

REQUEST NUMBER THREE
DOCUMENTS (SUBJECT)

Consumer Reports

Mazda CAC

ECI

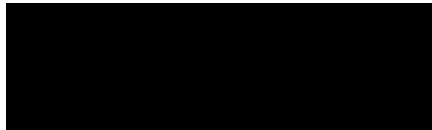



Concern Driven Reporting

Report Detail

Note: Field which are grayed (ghosted) are currently being mapped to the data warehouse. They are not presently being populated.

ECI Record		Source Code	MAZDA CAC
------------	--	-------------	-----------

Commodity Assignment			
Commodity	powertrain-engine—	Symptom	no keyword found
Commodity	powertrain-engine-accel pedal/linkage/controls—	Symptom	damage-catastrophic failure
Commodity	powertrain-engine-accel pedal/linkage/controls—	Symptom	leak/odor-fuel
Commodity	powertrain-engine-accel pedal/linkage/controls—	Symptom	pedal concerns-accelerator pedal
Commodity	powertrain-engine-accel pedal/linkage/controls—	Symptom	pressure-low
Commodity	powertrain-engine-accel pedal/linkage/controls—	Symptom	sticks/binds/grabs
Commodity	powertrain-engine-base engine—	Symptom	damage-catastrophic failure
Commodity	powertrain-engine-base engine—	Symptom	pressure-low
Commodity	powertrain-engine-base engine—	Symptom	sticks/binds/grabs
Significant Event		Verified	N

Tread Information	
Reported in Tread Quarter	Q4 2008

Report Details			
Source Claim Key		Warranty Component Classification (WCC)	
Corporate Product Systems Classification (CPSC)		Time in Service	
Customer Condition Code		V Function Group (VFG)	
Source System Program Type		Repair/Report/Paid Date	22-Oct-2008
Version Series Code	AAAGH	Load Date	08-Nov-2008
Causal Part Prefix- Base - Suffix	-	Dealer Code	UNKNOW
Causal Part Name	unknown	Dealer Name	
Non Causal Part Prefix-Base-Suffix		Dealer City	
Non Causal Part Numbers		Dealer State/Province	
Fault Code		Dealer Country	USA
Diagonstic Trouble Code		Dealer Phone Number	
Labor Operation Code		Attachment	
Communication Type		VOQ Component Description Code	
Maintenance Date	08-Nov-2008		

Customer Comment	CUST STS THE ENGINE IS BLOWN AND THE GAS PEDAL STICKS AND IS HARD TO PRESS DOWN. WANTS ALL REPAIRED UNDER WTTY OR EXT WTTY.
Technician Comment	LEFT ANOTHER PHONE MESSAGE FOR CUSTOMER ASKING HER TO CALL BACK TO DISCUSS. ADVISED CUSTOMER WILL BE CLOSING THE FILE THIS TIME, BUT CAN REFERENCE BACK IF SHE IS STILL SEEKING ASSISTANCE. 0012008 10 22CRPP254 REQ DESC BBB AUTO LINE CLAIM FORM CAS CALLED CUSTOMER AND LEFT MSG FOR CALL BACK REGARDING VEH ISSUES. 0022008 10 24CRPP254 EMAILED CUSTOMER. WAITING FOR REPLY. 0032008 10 28CRPP254 LEFT ANOTHER PHONE MESSAGE FOR CUSTOMER ASKING HER TO CALL BACK TO DISCUSS. ADVISED CUSTOMER WILL BE CLOSING THE FILE THIS TIME, BUT CAN REFERENCE BACK IF SHE IS STILL SEEKING ASSISTANCE.
CQIS Recommendations	

Tire Information			
Tire Manufacturer	Unknown	Tire Size	Unknown
Tire Brand Series		Wheel	
DOT Left Front		DOT Right Front	
DOT Left Rear		DOT Right Rear	
DOT Left Inner		DOT Right Inner	
DOT Spare			

Vehicle Information			
VIN	4F2YZ02Z26K	Engine Serial Number	290905155259
Model Year	2006	Engine Description	2.3L DOHC EGI I4 16V NA GAS
Transmission	4 SPD AUTO TRANS MAZDA CD4E	Vehicle Description	TRIBUTE
Body Cab Style	CA WE 5 DOOR LIGHT TRUCK	Drive Line	2 WHL L/H FRONT DRIVE
Production Date	12-Oct-2005	Retail Sale Indicator Code	
Plant Description	KANSAS CITY PLANT BUILD	Required Vehicle	
Build Region		Warranty Start Date	
Build Country Code		Transmission Serial Number	
Mileage	48000	Vehicle Axle Ratio	
Vehicle Restraint Code			

Disclaimer:

This data is for use as one of several potential "awareness" indicators for the Ford Motor Co. Enhanced Concern Identification System. It is unverified, draft, summary data generated from a computer "word search" of customer and technician symptom comments. Supplier data, technician and customer comments are unverified and actual root cause of any potential issue is not established by this summary.

[Contact ODRHELP](#)

Copyright 2001 Ford Motor Co All Rights Reserved

PE12-019

Mazda

9-6-2012

REQUEST NUMBER THREE
DOCUMENTS (SUBJECT)

Consumer Reports

Mazda CAC

ECI

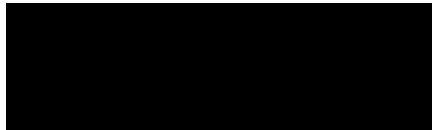



Concern Driven Reporting

Report Detail

Note: Field which are grayed (ghosted) are currently being mapped to the data warehouse. They are not presently being populated.

ECI Record		Source Code	MAZDA CAC
------------	--	-------------	-----------

Commodity Assignment

Commodity	Symptom	field service action
powertrain-engine—	Symptom	no keyword found
powertrain-engine—	Symptom	engine power-poor performance
powertrain-engine-accel pedal/linkage/controls—	Symptom	mod-driving condition-on acceleration
powertrain-engine-accel pedal/linkage/controls—	Symptom	mod-driving condition-while driving
powertrain-engine-accel pedal/linkage/controls—	Symptom	pedal concerns-accelerator pedal
powertrain-engine-accel pedal/linkage/controls—	Symptom	separation
powertrain-engine-accel pedal/linkage/controls—	Symptom	sticks/binds/grabs
powertrain-engine-air induction-throttle body-	Symptom	engine power-poor performance
powertrain-engine-air induction-throttle body-	Symptom	mod-driving condition-on acceleration
powertrain-engine-air induction-throttle body-	Symptom	mod-driving condition-while driving
powertrain-engine-air induction-throttle body-	Symptom	separation
powertrain-engine-air induction-throttle body-	Symptom	sticks/binds/grabs
Significant Event	Verified	N

Tread Information

Reported in Tread Quarter	Q4 2008
---------------------------	---------

Report Details

Source Claim Key	Warranty Component Classification (WCC)
Corporate Product Systems Classification (CPSC)	Time in Service
Customer Condition Code	V Function Group (VFG)
Source System Program Type	Repair/Report/Paid Date
Version Series Code	Load Date
Causal Part Prefix- Base - Suffix	Dealer Code
Causal Part Name	Dealer Name
Non Causal Part Prefix-Base-Suffix	Dealer City
Non Causal Part Numbers	Dealer State/Province
Fault Code	Dealer Country
Diagonstic Trouble Code	Dealer Phone Number
Labor Operation Code	Attachment
Communication Type	VOQ Component Description Code
Maintenance Date	14 -Dec-2008

Customer Comment CSTMER CLED ABOUT HIS VEHICLE; THOUGHT HIS WRTY WAS THROUGH MAZDA BUT FINDS IT'S NOT, A 3RD PARTY WRTY. 3RD PARTY WRTY DENIED HIS CLAIM BUT IS STILL WORKING WITH THEM. STS HIS GAS PEDAL IS STUCK, VEHICLE DOESN'T ACCELERATE. DIAGNOSIS IS \$197 TO DECARBONIZE HIS THROTTLE BODY. STS THE MAZDA DLER SHOULD ONLY SELL MEPP & NOT THE 3RD PARTY WRTY HE WAS SOLD.

Technician Comment FILE CLOSED AS CUSTOMER NEVER RE CONNECT. DEALER SERVICE ADVISED CUSTOMER HAD DECLINED SERVICE & WAS OUT OF WARRANTY. 0012008 10 14CRPP251 REQ DESC RECALL INQUIRY 0022008 10 22CRPP251 ADVISED CSTMER I WOULD RESEARCH HIS CONCERN ON THROTTLE BODY & RE CONNECT. LM FOR SVW MATT TO RE CONNECT WITH DIAGNOSIS. 0032008 12 11CRPP251 FILE CLOSED AS CUSTOMER NEVER RE CONNECT. DEALER SERVICE ADVISED CUSTOMER HAD DECLINED SERVICE & WAS OUT OF WARRANTY.

CQIS Recommendations

Tire Information

Tire Manufacturer	Tire Size
Unknown	Unknown
Tire Brand Series	Wheel
DOT Left Front	DOT Right Front
DOT Left Rear	DOT Right Rear
DOT Left Inner	DOT Right Inner
DOT Spare	

Vehicle Information

VIN	Engine Serial Number
4F2YZ02Z75K	
Model Year	Engine Description
2005	2.3L DOHC EGI I4 16V NA GAS
Transmission	Vehicle Description
5 SPD MAN TRANS MAZDA M5	TRIBUTE
Body Cab Style	Drive Line
CA WE 5 DOOR LIGHT TRUCK	2 WHL L/H FRONT DRIVE
Production Date	Retail Sale Indicator Code
31-Jan-2005	
Plant Description	Reaquired Vehicle
KANSAS CITY PLANT BUILD	
Build Region	Warranty Start Date
	27-Jun-2005
Build Country Code	Transmission Serial Number
Mileage	Vehicle Axle Ratio
63000	
Vehicle Restraint Code	

Disclaimer:

This data is for use as one of several potential "awareness" indicators for the Ford Motor Co. Enhanced Concern Identification System. It is unverified, draft, summary data generated from a computer "word search" of customer and technician symptom comments. Supplier data, technician and customer comments are unverified and actual root cause of any potential issue is not established by this summary.

[Contact ODRHELP](#)

Copyright 2001 Ford Motor Co All Rights Reserved

PE12-019

Mazda

9-6-2012

REQUEST NUMBER THREE
DOCUMENTS (SUBJECT)

Consumer Reports

Mazda CAC

ECI

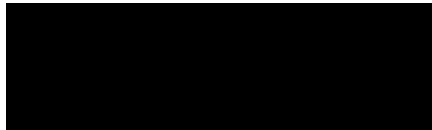



Concern Driven Reporting

Report Detail

Note: Field which are grayed (ghosted) are currently being mapped to the data warehouse. They are not presently being populated.

ECI Record		Source Code	MAZDA CAC
------------	--	-------------	-----------

Commodity Assignment			
Commodity	powertrain-engine	Symptom	mod-driving condition-on acceleration
Commodity	powertrain-engine	Symptom	mod-driving condition-while driving
Commodity	powertrain-engine	Symptom	no keyword found
Commodity	powertrain-engine-accel pedal/linkage/controls	Symptom	function-malfunction/inoperative
Commodity	powertrain-engine-accel pedal/linkage/controls	Symptom	pedal concerns-accelerator pedal
Commodity	powertrain-engine-accel pedal/linkage/controls	Symptom	sticks/binds/grabs
Significant Event		Verified	N

Tread Information	
Reported in Tread Quarter	Q1 2009

Report Details			
Source Claim Key		Warranty Component Classification (WCC)	
Corporate Product Systems Classification (CPSC)		Time in Service	
Customer Condition Code		V Function Group (VFG)	
Source System Program Type		Repair/Report/Paid Date	30-Jan-2009
Version Series Code	AAAGH	Load Date	02-Feb-2009
Causal Part Prefix-Base-Suffix	-	Dealer Code	42040
Causal Part Name	unknown	Dealer Name	SANTIA MARIA MAZDA
Non Causal Part Prefix-Base-Suffix		Dealer City	SANTIA MARIA
Non Causal Part Numbers		Dealer State/Province	CA
Fault Code		Dealer Country	USA
Diagonstic Trouble Code		Dealer Phone Number	8059250077
Labor Operation Code		Attachment	
Communication Type		VOQ Component Description Code	
Maintenance Date	02-Feb-2009		

Customer Comment	CUSTOMER STATES THAT ACCELERATOR PEDAL GETS STUCK THAT IT GETS STUCK AND IT DOESN'T GO. STATES THAT HE HASN'T TAKE VEHICLE BACK INTO SERVICE FOR A FEW MONTHS.		
Technician Comment	ADVISED CUSTOMER ON BELOW NOTES CUSTOMER DECLINED SERVICE STATES HE DID BECAUSE HE DID NOT WANT TO PERFORM ANY MAINTINANCE ON VEHICLE AT DEALER AND ONLY WANTED REPAIR BUT DECLINED AS WELL ADVISED CUSTOMER TO TAKE VEHICLE IN FOR SERVICE/DIAGNOSIS IN REGARDS TO CONCERN. SUGGEST TO CUSTOMER IF HE DOES NOT AGREE WITH DEALERSHIPS DIAGNOSIS TO TAKE VEHICLE IN TO ANOTHER LOCAL MAZDA DEALERSHIP CUSTOMER THANKED 0012009 01 30CRPP256 REQ DESC ACCELERATION CONTACTED SERVICE MANAGER AT DEALER# 42040 IN REGARDS TO CUSTOMER CONCERN WITH VEHICLE REPAIR STATES THAT CUSTOMER LAST BROUGHT VEHICLE IN FOR SERCICE ON 11 24 08 AND DECLINED SERVICE FOR CARBON BUILD UP, AND MAINTINANCE CONCERN STATES WAS NOT A WARRANTY REPAIR. CUSTOMER DECLINED REPAIR BECAUSE HE FELT THAT IT SHOULD BE WARRANTY REPAIR. ADVISED CUSTOMER ON BELOW NOTES CUSTOMER DECLINED SERVICE STATES HE DID BECAUSE HE DID NOT WANT TO PERFORM ANY MAINTINAN 0022009 01 30CRPP256 CE ON VEHICLE AT DEALER AND ONLY WANTED REPAIR BUT DECLINED AS WELL ADVISED CUSTOMER TO TAKE VEHICLE IN FOR SERVICE/DIAGNOSIS IN REGARDS TO CONCERN. SUGGEST TO CUSTOMER IF HE DOES NOT AGREE WITH DEALERSHIPS DIAGNOSIS TO TAKE VEHICLE IN TO ANOTHER LOCAL MAZDA DEALERSHIP CUSTOMER THANKED		
CQIS Recommendations			

Tire Information			
Tire Manufacturer	Unknown	Tire Size	Unknown
Tire Brand Series		Wheel	
DOT Left Front		DOT Right Front	
DOT Left Rear		DOT Right Rear	
DOT Left Inner		DOT Right Inner	
DOT Spare			

Vehicle Information			
VIN	4F2YZ0Z25K	Engine Serial Number	
Model Year	2005	Engine Description	2.3L DOHC EGI I4 16V NA GAS
Transmission	4 SPD AUTO TRANS MAZDA CD4E	Vehicle Description	TRIBUTE
Body Cab Style	CA WE 3 DOOR LIGHT TRUCK	Drive Line	2 WHL L/H FRONT DRIVE
Production Date	27-Oct-2004	Retail Sale Indicator Code	
Plant Description	KANSAS CITY PLANT BUILD	Reaquired Vehicle	
Build Region		Warranty Start Date	
Build Country Code		Transmission Serial Number	
Mileage	45000	Vehicle Axle Ratio	
Vehicle Restraint Code			

Disclaimer:

This data is for use as one of several potential "awareness" indicators for the Ford Motor Co. Enhanced Concern Identification System. It is unverified, draft, summary data generated from a computer "word search" of customer and technician symptom comments. Supplier data, technician and customer comments are unverified and actual root cause of any potential issue is not established by this summary.

[Contact ODRHELP](#)

Copyright 2001 Ford Motor Co All Rights Reserved

PE12-019

Mazda

9-6-2012

REQUEST NUMBER THREE
DOCUMENTS (SUBJECT)

Consumer Reports

Mazda CAC

ECI

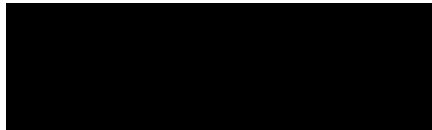



Concern Driven Reporting

Report Detail

Note: Field which are grayed (ghosted) are currently being mapped to the data warehouse. They are not presently being populated.

ECI Record		Source Code	MAZDA CAC
------------	--	-------------	-----------

Commodity Assignment

Commodity	powertrain-engine	Symptom	no keyword found
Commodity	powertrain-engine-accel pedal/linkage/controls	Symptom	pedal concerns-accelerator pedal
Commodity	powertrain-engine-accel pedal/linkage/controls	Symptom	sticks/binds/grabs
Significant Event		Verified	N

Tread Information

Reported in Tread Quarter	Q2 2009
---------------------------	---------

Report Details

Source Claim Key		Warranty Component Classification (WCC)	
Corporate Product Systems Classification (CPSC)		Time in Service	108
Customer Condition Code		V Function Group (VFG)	
Source System Program Type		Repair/Report/Paid Date	25-Jun-2009
Version Series Code	AAAA5	Load Date	05-Jul-2009
Causal Part Prefix-Base-Suffix	-	Dealer Code	60433
Causal Part Name	unknown	Dealer Name	BASNEY MAZDA
Non Causal Part Prefix-Base-Suffix		Dealer City	SOUTH BEND
Non Causal Part Numbers		Dealer State/Province	IN
Fault Code		Dealer Country	USA
Diagonstic Trouble Code		Dealer Phone Number	5742728504
Labor Operation Code		Attachment	
Communication Type		VOQ Component Description Code	
Maintenance Date	05-Jul-2009		

Customer Comment	CUSTOMER CALLED, 2ND OWNER, THE THROTTLE CABLE IS STICKING. CUSTOMER HAS NOT TAKEN VEHICLE INTO THE DEALER. FEELS THIS IS A SAFETY ISSUE AND SHOULD BE COVERED BY MAZDA. HAS RESEARCHED THE THROTTLE CABLE ONLINE AND CAN'T UNDERSTAND WHY HER VEHICLE DOESN'T QUALIFY.		
Technician Comment	NO RE CONNECT FROM CUSTOMER NOR DEALER SERVICE. 0012009 06 25CRPP251 REQ DESC RECALL INQUIRY LEFT MESSAGE FOR DEALER SERVICE, ADVISED CUSTOMER MIGHT COME IN BUT MADE NO PROMISE OF AWA. CONFIRMED NO RECALL SHOWING FOR THROTTLE CABLE. LEFT CONTACT INFO. 0022009 06 29CRPP251 NO RE CONNECT FROM CUSTOMER NOR DEALER SERVICE.		
CQIS Recommendations			

Tire Information

Tire Manufacturer	Unknown	Tire Size	Unknown
Tire Brand Series		Wheel	
DOT Left Front		DOT Right Front	
DOT Left Rear		DOT Right Rear	
DOT Left Inner		DOT Right Inner	
DOT Spare			

Vehicle Information

VIN	4F2CU08161K	Engine Serial Number	511843038
Model Year	2001	Engine Description	3.0L DOHC EGI V6 NA*GAS
Transmission	4 SPD AUTO TRANS MAZDA CD4E	Vehicle Description	TRIBUTE
Body Cab Style	CA WE 3 DOOR LIGHT TRUCK	Drive Line	4 WHL L/H PART TIME DRIVE
Production Date	19-Jul-2000	Retail Sale Indicator Code	
Plant Description	KANSAS CITY PLANT BUILD	Reaquired Vehicle	
Build Region		Warranty Start Date	07-Sep-2000
Build Country Code		Transmission Serial Number	
Mileage	92000	Vehicle Axle Ratio	
Vehicle Restraint Code			

Disclaimer:

This data is for use as one of several potential "awareness" indicators for the Ford Motor Co. Enhanced Concern Identification System. It is unverified, draft, summary data generated from a computer "word search" of customer and technician symptom comments. Supplier data, technician and customer comments are unverified and actual root cause of any potential issue is not established by this summary.

[Contact ODRHELP](#)

Copyright 2001 Ford Motor Co All Rights Reserved

PE12-019

Mazda

9-6-2012

REQUEST NUMBER THREE
DOCUMENTS (SUBJECT)

Consumer Reports

Mazda CAC

ECI

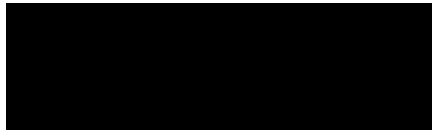



Concern Driven Reporting

Report Detail

Note: Field which are grayed (ghosted) are currently being mapped to the data warehouse. They are not presently being populated.

ECI Record		Source Code	MAZDA CAC
Commodity Assignment			
Commodity	powertrain-engine---	Symptom	circuit-open
Commodity	powertrain-engine---	Symptom	function-malfunction/inoperative
Commodity	powertrain-engine---	Symptom	no keyword found
Commodity	powertrain-engine---	Symptom	repair-similar failures on other vehicles mentioned
Commodity	powertrain-engine---	Symptom	separation
Commodity	powertrain-engine-accel pedal/linkage/controls---	Symptom	engine power-stall
Commodity	powertrain-engine-accel pedal/linkage/controls---	Symptom	function-malfunction/inoperative
Commodity	powertrain-engine-accel pedal/linkage/controls---	Symptom	mod-driving condition-while driving
Commodity	powertrain-engine-accel pedal/linkage/controls---	Symptom	mod-intermittent/random
Commodity	powertrain-engine-accel pedal/linkage/controls---	Symptom	mod-vehicle towed in
Commodity	powertrain-engine-accel pedal/linkage/controls---	Symptom	pedal concerns-accelerator pedal
Commodity	powertrain-engine-accel pedal/linkage/controls---	Symptom	repair-prior repair mentioned
Commodity	powertrain-engine-accel pedal/linkage/controls---	Symptom	sticks/binds/grabs
Commodity	powertrain-engine-air induction-throttle body-	Symptom	engine power-stall
Commodity	powertrain-engine-air induction-throttle body-	Symptom	function-malfunction/inoperative
Commodity	powertrain-engine-air induction-throttle body-	Symptom	mod-driving condition-while driving
Commodity	powertrain-engine-air induction-throttle body-	Symptom	mod-intermittent/random
Commodity	powertrain-engine-air induction-throttle body-	Symptom	mod-vehicle towed in
Commodity	powertrain-engine-air induction-throttle body-	Symptom	repair-prior repair mentioned
Commodity	powertrain-engine-air induction-throttle body-	Symptom	sticks/binds/grabs
Commodity	powertrain-engine-electronic engine control---	Symptom	engine power-stall
Commodity	powertrain-engine-electronic engine control---	Symptom	function-malfunction/inoperative
Commodity	powertrain-engine-electronic engine control---	Symptom	mod-driving condition-while driving
Commodity	powertrain-engine-electronic engine control---	Symptom	mod-intermittent/random
Commodity	powertrain-engine-electronic engine control---	Symptom	mod-vehicle towed in
Commodity	powertrain-engine-electronic engine control---	Symptom	repair-prior repair mentioned
Commodity	powertrain-engine-electronic engine control---	Symptom	sticks/binds/grabs
Commodity	powertrain-engine-miscellaneous controls---	Symptom	engine power-stall
Commodity	powertrain-engine-miscellaneous controls---	Symptom	function-malfunction/inoperative
Commodity	powertrain-engine-miscellaneous controls---	Symptom	mod-driving condition-while driving
Commodity	powertrain-engine-miscellaneous controls---	Symptom	mod-intermittent/random
Commodity	powertrain-engine-miscellaneous controls---	Symptom	mod-vehicle towed in
Commodity	powertrain-engine-miscellaneous controls---	Symptom	repair-prior repair mentioned
Commodity	powertrain-engine-miscellaneous controls---	Symptom	sticks/binds/grabs
Commodity	powertrain-engine-valve train---	Symptom	engine power-stall
Commodity	powertrain-engine-valve train---	Symptom	function-malfunction/inoperative
Commodity	powertrain-engine-valve train---	Symptom	mod-driving condition-while driving
Commodity	powertrain-engine-valve train---	Symptom	mod-intermittent/random
Commodity	powertrain-engine-valve train---	Symptom	mod-vehicle towed in
Commodity	powertrain-engine-valve train---	Symptom	repair-prior repair mentioned
Commodity	powertrain-engine-valve train---	Symptom	sticks/binds/grabs
Significant Event		Verified	N

Tread Information	
Reported in Tread Quarter	Q2 2009

Report Details			
Source Claim Key		Warranty Component Classification (WCC)	
Corporate Product Systems Classification (CPSC)		Time in Service	57
Customer Condition Code		V Function Group (VFG)	
Source System Program Type		Repair/Report/Paid Date	26-Jun-2009
Version Series Code	AAAGJ	Load Date	05-Jul-2009
Causal Part Prefix- Base - Suffix	- -	Dealer Code	23725
Causal Part Name	unknown	Dealer Name	ANDY JONES MAZDA
Non Causal Part Prefix-Base-Suffix		Dealer City	NORTH AUGUSTIA
Non Causal Part Numbers		Dealer State/Province	SC
Fault Code		Dealer Country	USA
Diagnostic Trouble Code		Dealer Phone Number	
Labor Operation Code		Attachment	
Communication Type		VOQ Component Description Code	
Maintenance Date	05-Jul-2009		

Customer Comment CALLED ABOUT HAVING TO REPAIR THE VEHICLE, TOWED INTO DEALER SUNDAY NIGHT, 06/21/09 WITH PROBLEM OF ENGINE CUTTING OUT/THROTTLE STICKING. DIAGNOSED INTERMITTENT IDLE CONTROL VALVE, IAC & THROTTLE BODY. DEALER ADVISED THROTTLE BODY WAS THE PROBLEM. PICKED UP VEHICLE LAST NIGHT AND NOW BACK INTO DEALER FOR SAME PROBLEM. STEVEN IN SERVICE. WORK ██████████ WANTS TO KNOW WHY THIS IS HAPPENING AT 72,000 MILES.

Technician Comment	ATTN DCSM/SVM PER CONVERSATION WITH STEVE, SERVICE MANAGER, DEALER IS WORKING WITH MEPP ON REPAIRING THE VEHICLE. PLEASE CLOSE UPON RESOLUTION. THANKS. 0012009 06 26CRPP251 REQ DESC VEHICLE SERVICE INQUIRY ADVISED I WOULD RESEARCH & RE CONNECT. 0022009 06 30CRPP251 AT ATTN DCSM/SVM PER CONVERSATION WITH STEVE, SERVICE MANAGER, DEALER IS WORKING WITH MEPP ON REPAIRING THE VEHICLE. PLEASE CLOSE UPON RESOLUTION. THANKS. STEVE, SERVICE MANAGER ADVISED CUSTOMER REQUESTED ALL HIS REPLACED PARTS, CUSTOMER KEEPS INSISTING HE'S NEVER HAD THESE PROBLEMS WITH ANOTHER VEHICLE, CONFIRMED THROTTLE SENSOR PROBLEMS/CODES FOR THROTTLE SENSOR REMAINS OPEN, RECOMMENDED BASIC CLEANING MAINTENANCE OF THROTTLE, INJECTOR & TEST DROVE OK. CUSTOMER RETURNED NEXT DAY AND NOW DIAGNOSED TORQUE CONV 0032009 06 30CRPP251 ERTOR SOLENOID & TRYING TO WORK WITH MEPP. CONFIRMED CUSTOMER HAS SPENT MONEY AT DEALER. ADVISED I WOULD FORWARD FILE TO DEALER. ADVISED CUSTOMER STEVE, SERVICE MANAGER IS WORKING ON CUSTOMER CONCERNS AND WILL RE CONNECT IF FURTHER PROBLEMS ARISE.
CQIS Recommendations	

Tire Information			
Tire Manufacturer	Unknown	Tire Size	Unknown
Tire Brand Series		Wheel	
DOT Left Front		DOT Right Front	
DOT Left Rear		DOT Right Rear	
DOT Left Inner		DOT Right Inner	
DOT Spare			

Vehicle Information			
VIN	4F2YZ04155K [REDACTED]	Engine Serial Number	
Model Year	2005	Engine Description	3.0L DOHC EGI V6 NA*G DSP2967
Transmission	4 SPD AUTO TRANS MAZDA CD4E	Vehicle Description	TRIBUTE
Body Cab Style	CA WE 5 DOOR LIGHT TRUCK	Drive Line	2 WHL L/H FRONT DRIVE
Production Date	30-Aug-2004	Retail Sale Indicator Code	
Plant Description	KANSAS CITY PLANT BUILD	Required Vehicle	
Build Region		Warranty Start Date	05-Nov-2004
Build Country Code		Transmission Serial Number	
Mileage	72400	Vehicle Axle Ratio	
Vehicle Restraint Code			

Disclaimer:

This data is for use as one of several potential "awareness" indicators for the Ford Motor Co. Enhanced Concern Identification System. It is unverified, draft, summary data generated from a computer "word search" of customer and technician symptom comments. Supplier data, technician and customer comments are unverified and actual root cause of any potential issue is not established by this summary.

[Contact CDR HELP](#)
 Copyright 2001 Ford Motor Co. All Rights Reserved

PE12-019

Mazda

9-6-2012

REQUEST NUMBER THREE
DOCUMENTS (SUBJECT)

Consumer Reports

Mazda CAC

ECI

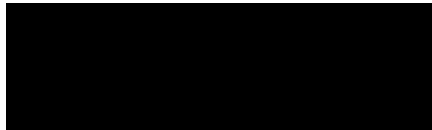



Concern Driven Reporting

Report Detail

Note: Field which are grayed (ghosted) are currently being mapped to the data warehouse. They are not presently being populated.

ECI Record		Source Code	MAZDA CAC
------------	--	-------------	-----------

Commodity Assignment

Commodity	Symptom	
powertrain-engine—	Symptom	damage-cracked/fractured/split
powertrain-engine—	Symptom	function-malfunction/inoperative
powertrain-engine—	Symptom	mod-driving condition-engine-hot
powertrain-engine—	Symptom	no keyword found
powertrain-engine—	Symptom	pedal concerns-accelerator pedal
powertrain-engine-accel pedal/linkage/controls—	Symptom	engine rpm surge/flare
powertrain-engine-accel pedal/linkage/controls—	Symptom	function-malfunction/inoperative
powertrain-engine-accel pedal/linkage/controls—	Symptom	pedal concerns-accelerator pedal
powertrain-engine-base engine-seals and gaskets (not oil pan or head gasket)-	Symptom	function-malfunction/inoperative
powertrain-engine-base engine-seals and gaskets (not oil pan or head gasket)-	Symptom	mod-driving condition-at cruise
powertrain-engine-base engine-seals and gaskets (not oil pan or head gasket)-	Symptom	mod-driving condition-when engine/ignition turned off
powertrain-engine-base engine-seals and gaskets (not oil pan or head gasket)-	Symptom	mod-driving condition-while driving
powertrain-engine-base engine-seals and gaskets (not oil pan or head gasket)-	Symptom	no keyword found
Significant Event	Verified	Y

Tread Information

Reported in Tread Quarter	Q3 2009
---------------------------	---------

Report Details

Source Claim Key		Warranty Component Classification (WCC)	
Corporate Product Systems Classification (CPSC)		Time in Service	92
Customer Condition Code		V Function Group (VFG)	
Source System Program Type		Repair/Report/Paid Date	20-Aug-2009
Version Series Code	AAAQK	Load Date	05-Oct-2009
Causal Part Prefix- Base - Suffix	-	Dealer Code	10169
Causal Part Name	unknown	Dealer Name	PARR MAZDA
Non Causal Part Prefix-Base-Suffix		Dealer City	BREMERTON
Non Causal Part Numbers		Dealer State/Province	WA
Fault Code		Dealer Country	USA
Diagonstic Trouble Code		Dealer Phone Number	
Labor Operation Code		Attachment	
Communication Type		VOQ Component Description Code	
Maintenance Date	05-Oct-2009		

Customer Comment	CUSTOMER STATES THAT SHE HAD THE RECALL ON HER ACCELERATOR CABLE DONE ABOUT 2 YEARS. ON MONDAY HER ACCELERATOR PEDAL DID NOT RETURN TO IDLE AND HAD TO BURN THROUGH THE BRAKE PAD AND ROTORS IN ORDER TO STOP THE CAR. TOOK THE CAR TO AN INDEPENDENT SHOP WHO DETERMINED THAT THE ACCELERATOR CABLE NEEDED TO BE REPLACED. RECALL DONE IN 2005.
------------------	--

Technician Comment	<p>ATTN DCSM/SVM PER CONVERSATION, PLEASE REVIEW REQUEST FOR INSPECTION OF BROKEN ACCELERATOR CABLE, PLEASE CONTACT AGENT UPON RESOLUTION. THANKS. PAUL STEINBRUNER 949 727 6691 VEHICLE HAS ISSUE WITH CABLE CONTACT WITH ENGINE COVER GAVE CUSTOMER EST. CUSTOMER DECLINED REPAIR AGENT CLOSED DUE TO INACTIVITY. 0012009 08 20CRPP172 AT ATTN DCSM/SVM PER CONVERSATION, PLEASE REVIEW REQUEST FOR INSPECTION OF BROKEN ACCELERATOR CABLE, PLEASE CONTACT AGENT UPON RESOLUTION. THANKS. PAUL STEINBRUNER 949 727 6691 REQ DESC BROKEN ACCELERATOR CABLE AGENT CONTACTED DEALER, SPOKE TO GREG STEEL. INFORMED GREG THAT AGENT ADVISED CUSTOMER TO BRING VEHICLE INTO DEALERSHIP FOR INSPECTION OF BROKEN PART AND INSTALLATION. AGENT ADVISED THAT MAZDA WOULD COVER DIAGNOSES, \$50, VIA AUTHORIZATION. AGENT REQUESTED CALL BACK WITH FINDINGS. AGENT WILL SEND FIL 0022009 08 20CRPP172 E TO DEALER FOR REVIEW. 0032009 08 24CRPP172 GREG STEEL AT DEALER STATED CRUISE CONTROL CABLE WAS CAUGHT ON THE ENGINE COVER. STATED THE TECHNITION FOUND NOTHING WRONG WITH THE THROTTLE CABLE. STATED THAT THE INDEPEDENT SHOP REPLACED THE BRAKES AND THROTTLE CABLE. DEALER INSPECTED THE THROTTLE CABLE THAT WAS REPLACED FOR PROPER OPERATION. STATED HE HAD SPOKEN TO THE CUSTOMER WHO WAS CONCERENED THERE WAS STILL A SAFTEY ISSUE WITH THE VEHICLE. DEALER STATED THAT THE CAR IS PERFECTLY SAFE TO DRIVE WITH THE ENGINE COVER OFF. DEALER WILL CALL AGENT WITH COST OF REPAIR. AGENT WILL THE 0042009 08 24CRPP172 N MAKE AWA DECISION AND CONTACT CUSTOMER. 0052009 08 25CRPP172 AT ATTN DCSM/GREG STEEL PER CONVERSATION, PLEASE REVIEW REQUEST, AGENT HAS AUTHORIZED FOR REPAIRS TO BE DONE AT NO COST TO CUSTOMER. PLEASE CLOSE UPON COMPLETION OF REPAIR THANKS. PAUL STEINBRUNER 949 727 6691 LEFT MESSAGE FOR GREG REQUESTING CALL BACK. GREG FROM DEALERSHIP CALLED. RECIEVED PRICE FOR PART EC50 66 312D, CRUISE CONTROL ACTUATOR, WARRANTY PRICE \$255.86 + 1 HOUR LABOR AT 89.50 (RETAIL PRICE). AGENT ADVISED THAT MAZDA WOULD PAY FOR COST OF REPAIR AND AUTHORIZE \$350.00 FOR REPAI 0062009 08 25CRPP172 RS. FILE NUMBER GIVEN TO GREG FOR AUTHORIZATION. GREG WILL CONTACT CUSTOMER WITH INFORMATION. 0072009 09 16CRPP172 VEHICLE HAS ISSUE WITH CABLE CONTACT WITH ENGINE COVER GAVE CUSTOMER EST. CUSTOMER DECLINED REPAIR [REDACTED] DEALER CALLED IN FOR AGENT. WARM TRANSFERRED WITH PERMISSION. 0092009 09 18CRPP172 GREG FROM DEALER 10169 CALLED. STATED THAT THEY SUBMITTED A CLAIM FOR THE LABOR WHICH WENT THROUGH. STATES THAT THE CLAIM FOR THE PARTS KEEP ON COMING BACK. AGENT ADVISED THAT HE IS AWARE OF THE SITUATION AND SUBMITTED AN UPDATED CLAIM THIS MORNING. ADVISED THAT IF THE CLAIM COMES BACK AGAIN HE WILL SPEAK WITH HIS SUPERVISOR ON HOW TO APPROVE IT. AGENT REQUESTED FOR GREG TO UPDATE CLOSING NOTES ON FILE SINCE CUSTOMER DID HAVE THE REPAIR PERFORMED. 0102009 10 06CRPP172 AGENT CLOSED DUE TO INACTIVITY. 0112009 10 07CRPP206 GREG FROM DEALERSHIP CALLED BACK AND REQUESTED TO SPEAK WITH PAUL. TRANSFERRED GREG TO PAUL WITH PERMISSION. 0122009 10 07CRPP172 GREG FROM DEALER 10169 CALLED STATING THAT THE WARRANTY PAYMENT HAD NOT GONE THROUGH. AGENT ADVISED THAT HE SUBMITTED THE WARRANTY DOCUMENTATION ON 9/18 AND HAS NOT RECIEVED AT NOTIFICATION SINCE THEN. GREG ADVISED THAT HE WILL CHECK WITH HIS WARRANTY DEPARMENT TO SEE IF IT HAS SINCE GONE THROUGH. AGENT PROVIDED GREG WITH DIRECT LINE. 0132009 10 15CRPP172 DEBBY PARR FROM DEALER 10169 CALLED. STATED THAT GREG STEEL IS NO LONGER WITH DEALERSHIP. ADVISED THAT THE PAYMENT FOR THE PART HAS STILL NOT GONE THROUGH. AGENT ADVISED THAT HE HAD PUT THE AUTHORIZATION THROUGH AND IT HAS NOT COME BACK AS INVAILID. AGENT SPOKE WITH SUPERVISOR LINDA WHO ADVISED SHE WILL MANUALLY APPROVE THE CLAIM. AGENT ADVISED DEBBY THAT SUPERVISOR WILL APPROVE WORK. DEBBY REQUESTED TO BE CONTACTED WHEN AUTHORIZATION HAS BEEN COMPLETED. EXT 1244. 0142009 11 12CRPP172 AGENT UPDATED WARRANTY APPROVAL TO REFLECT THAT THE AUTHORIZATION COVERS PARTS.</p>
CQIS Recommendation	

Tire Information

Tire Manufacturer	Unknown	Tire Size	Unknown
Tire Brand Series		Wheel	
DOT Left Front		DOT Right Front	
DOT Left Rear		DOT Right Rear	
DOT Left Inner		DOT Right Inner	
DOT Spare			

Vehicle Information

VIN	4F2YU081X2K [REDACTED]	Engine Serial Number	206301087
Model Year	2002	Engine Description	3.0L DOHC EGI V6 NA *GAS
Transmission	4 SPD AUTO TRANS MAZDA CD4E	Vehicle Description	TRIBUTE
Body Cab Style	CA WE 5 DOOR LIGHT TRUCK	Drive Line	4 WHL L/H PART TIME DRIVE
Production Date	18-Dec-2001	Retail Sale Indicator Code	
Plant Description	KANSAS CITY PLANT BUILD	Reaquired Vehicle	
Build Region		Warranty Start Date	17-Feb-2002
Build Country Code		Transmission Serial Number	
Mileage	113000	Vehicle Axle Ratio	
Vehicle Restraint Code			

Disclaimer:

This data is for use as one of several potential "awareness" indicators for the Ford Motor Co. Enhanced Concern Identification System. It is unverified, draft, summary data generated from a computer "word search" of customer and technician symptom comments. Supplier data, technician and customer comments are unverified and actual root cause of any potential issue is not established by this summary.

PE12-019

Mazda

9-6-2012

REQUEST NUMBER THREE
DOCUMENTS (SUBJECT)

Consumer Reports

Mazda CAC

ECI

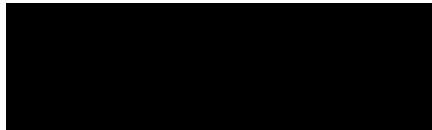



Concern Driven Reporting

Report Detail

Note: Field which are grayed (ghosted) are currently being mapped to the data warehouse. They are not presently being populated.

ECI Record		Source Code	MAZDA CAC
------------	--	-------------	-----------

Commodity Assignment

Commodity	powertrain-engine	Symptom	no keyword found
Commodity	powertrain-engine	Symptom	pedal concerns-accelerator pedal
Commodity	powertrain-engine	Symptom	sticks/binds/grabs
Commodity	powertrain-engine-accel pedal/linkage/controls	Symptom	function-malfunction/inoperative
Commodity	powertrain-engine-accel pedal/linkage/controls	Symptom	mod-driving condition-on grade
Commodity	powertrain-engine-accel pedal/linkage/controls	Symptom	pedal concerns-accelerator pedal
Commodity	powertrain-engine-accel pedal/linkage/controls	Symptom	sticks/binds/grabs
Significant Event		Verified	Y

Tread Information

Reported in Tread Quarter Q4 2009

Report Details

Source Claim Key		Warranty Component Classification (WCC)	
Corporate Product Systems Classification (CPSC)		Time in Service	61
Customer Condition Code		V Function Group (VFG)	
Source System Program Type		Repair/Report/Paid Date	01-Dec-2009
Version Series Code	AAAGH	Load Date	06-Dec-2009
Causal Part Prefix-Base-Suffix	-	Dealer Code	UNKNOW
Causal Part Name	unknown	Dealer Name	
Non Causal Part Prefix-Base-Suffix		Dealer City	
Non Causal Part Numbers		Dealer State/Province	
Fault Code		Dealer Country	USA
Diagnostic Trouble Code		Dealer Phone Number	
Labor Operation Code		Attachment	
Communication Type		VOQ Component Description Code	
Maintenance Date	06-Dec-2009		

Customer Comment
CUSTOMER EMAILED; MY CAR IS CURRENTLY IN THE SHOP BECAUSE THE GAS PEDAL GOT STUCK LAST NIGHT AND I COULDN'T GET IT UP THE HILL I WAS CLIMBING. I WAS ON A BUSY STREET AND HAD TO WAIT IN THE MIDDLE OF THE ROAD UNTIL ALL THE TRAFFIC PASSED SO I COULD ROLL BACKWARDS ONTO A SIDE STREET. IT WAS A VERY DANGEROUS SITUATION. WHEN I GOT HOME I GOOGLED THIS AND FOUND THAT MANY PEOPLE ARE HAVING THE SAME PROBLEM AND SEVERAL HAVE HAD ACCIDENTS.

Technician Comment
CONFIRMED CUSTOMER HAS NO OPEN RECALLS & ADVISED CUSTOMER TO POSSIBLY INVESTIGATE A DEALER DIAGNOSIS & POSSIBLE AWA. 0012009 12 01CRPP251 REQ DESC STUCK ACCELERATOR CONCERN CONTINUED; MY CAR HAS 32,000 MILES ON IT BUT IS OUT OF WARRANTY BECAUSE OF ITS AGE. I FEEL THAT YOU SHOULD RECALL THESE VEHICLES AND FIX THE PROBLEM BECAUSE IT IS A SAFETY ISSUE AND EVENTUALLY SOMEONE WILL BE SERIOUSLY HURT. HI MS. SELIG, THANK YOU FOR CONTACTING MAZDA AND MY APOLOGIES FOR THE VEHICLE CONCERNS. I FOUND NO RECALL FOR THE CONCERN YOU DESCRIBE. I WOULD RECOMMEND THAT YOU SEEK A DIAGNOSIS FROM A MAZDA DEALER. THEY WOULD BE ABLE TO TELL MAZDA IF THE 0022009 12 01CRPP251 Y FEEL YOUR PARTICULAR CONCERN WOULD WARRANT WARRANTY ASSISTANCE. WE APPRECIATE YOUR TAKING THE TIME TO INFORM US ABOUT YOUR RECENT VEHICLE EXPERIENCE. SINCERELY, FRANK BRCAK REPRESENTATIVE, MAZDA CUSTOMER ASSISTANCE CONFIRMED CUSTOMER HAS NO OPEN RECALLS & ADVISED CUSTOMER TO POSSIBLY INVESTIGATE A DEALER DIAGNOSIS & POSSIBLE AWA.

CQIS Recommendations

Tire Information

Tire Manufacturer	Unknown	Tire Size	Unknown
Tire Brand Series		Wheel	
DOT Left Front		DOT Right Front	
DOT Left Rear		DOT Right Rear	
DOT Left Inner		DOT Right Inner	
DOT Spare			

Vehicle Information

VIN	4F2YZ92Z25K	Engine Serial Number	
Model Year	2005	Engine Description	2.3L DOHC EGI I4 16V NA GAS
Transmission	5 SPD MAN TRANS MAZDA M5	Vehicle Description	TRIBUTE
Body Cab Style	CA WE 5 DOOR LIGHT TRUCK	Drive Line	4 WHL L/H PART TIME DRIVE
Production Date	27-Aug-2004	Retail Sale Indicator Code	
Plant Description	KANSAS CITY PLANT BUILD	Required Vehicle	
Build Region		Warranty Start Date	18-Dec-2004
Build Country Code		Transmission Serial Number	
Mileage	32000	Vehicle Axle Ratio	
Vehicle Restraint Code			

Disclaimer:

This data is for use as one of several potential "awareness" indicators for the Ford Motor Co. Enhanced Concern Identification System. It is unverified, draft, summary data generated from a computer "word search" of customer and technician symptom comments. Supplier data, technician and customer comments are unverified and actual root cause of any potential issue is not established by this summary.

[Contact ODRHELP](#)

Copyright 2001 Ford Motor Co All Rights Reserved

PE12-019

Mazda

9-6-2012

REQUEST NUMBER THREE
DOCUMENTS (SUBJECT)

Consumer Reports

Mazda CAC

ECI

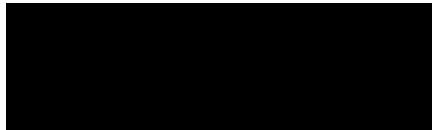



Concern Driven Reporting

Report Detail

Note: Field which are grayed (ghosted) are currently being mapped to the data warehouse. They are not presently being populated.

ECI Record		Source Code	MAZDA CAC
------------	--	-------------	-----------

Commodity Assignment			
Commodity	powertrain-engine—	Symptom	no keyword found
Commodity	powertrain-engine—	Symptom	pedal concerns-accelerator pedal
Commodity	powertrain-engine—	Symptom	sticks/binds/grabs
Commodity	powertrain-engine-accel pedal/linkage/controls—	Symptom	field service action
Commodity	powertrain-engine-accel pedal/linkage/controls—	Symptom	pedal concerns-accelerator pedal
Commodity	powertrain-engine-accel pedal/linkage/controls—	Symptom	sticks/binds/grabs
Commodity	powertrain-engine-air induction-throttle body-	Symptom	field service action
Commodity	powertrain-engine-air induction-throttle body-	Symptom	sticks/binds/grabs
Commodity	powertrain-engine-electronic engine control—	Symptom	field service action
Commodity	powertrain-engine-electronic engine control—	Symptom	sticks/binds/grabs
Commodity	powertrain-engine-miscellaneous controls—	Symptom	field service action
Commodity	powertrain-engine-miscellaneous controls—	Symptom	sticks/binds/grabs
Significant Event		Verified	Y

Tread Information	
Reported in Tread Quarter	Q4 2009

Report Details			
Source Claim Key		Warranty Component Classification (WCC)	
Corporate Product Systems Classification (CPSC)		Time in Service	100
Customer Condition Code		V Function Group (VFG)	
Source System Program Type		Repair/Report/Paid Date	02-Dec-2009
Version Series Code	AAAAX	Load Date	06-Dec-2009
Causal Part Prefix - Base - Suffix	- -	Dealer Code	51608
Causal Part Name	unknown	Dealer Name	LIBERTY MAZDA
Non Causal Part Prefix-Base-Suffix		Dealer City	WAKEFIELD
Non Causal Part Numbers		Dealer State/Province	MA
Fault Code		Dealer Country	USA
Diagnostic Trouble Code		Dealer Phone Number	7812458000
Labor Operation Code		Attachment	
Communication Type		VOQ Component Description Code	
Maintenance Date	06-Dec-2009		

Customer Comment	CUSTOMER STATES VEHICLE INVOLVED IN ACCIDENT ACCELERATOR BINDING, THROTTLE BODY DIRTY AND BINDING, IAC VALVE WAS STUCK OPEN. LIBERTY MAZDA INSPECTED VEHICLE AND STATED THIS WAS THE CAUSE OF THE ACCIDENT. THE ACCELERATOR REPAIRED EARLIER UNDER RECALL. THEN THE VEHICLE IN ACCIDENT 10/13/2009 AND VEHICLE REPAIRED BY MAZDA DEALER (\$4000).
Technician Comment	AGENT CONFIRMED CUSTOMER INSURANCE COMPANY INVOLVED. AGENT ADVISED CUSTOMER IF INSURANCE COMPANY CONCLUDES VEHICLE DEFECT CAUSE OF ACCIDENT THEN THE INSURANCE COMPANY NEEDS TO SUBMIT IN WRITING ON COMPANY LETTER HEAD WHAT THEIR FINDINGS ARE. IN AN ACCIDENT MAZDA DOES NOT INVESTIGATE CAUSE OF ACCIDENT. 0012009 12 02CRPP235 REQ DESC ACCIDENT VEHICLE IN 2ND ACCIDENT FOR ACCELERATOR STICKING AND NOW THE MAZDA DEALER AFTER TALKING TO MAZDA WILL NOT TOUCH VEHICLE OR INSPECT. CUSTOMER INQUIRED WHY, VEHICEL MIGHT BE TOTALED AGENT CONFIRMED CUSTOMER INSURANCE COMPANY INVOLVED. AGENT ADVISED CUSTOMER IF INSURANCE COMPANY CONCLUDES VEHICLE DEFECT CAUSE OF ACCIDENT THEN THE INSURANCE COMPANY NEEDS TO SUBMIT IN WRITING ON COMPANY LETTER HEAD WHAT THEIR FINDINGS AR 0022009 12 02CRPP235 E. IN AN ACCIDENT MAZDA DOES NOT INVESTIGATE CAUSE OF ACCIDENT.
CQIS Recommendations	

Tire Information			
Tire Manufacturer	Unknown	Tire Size	Unknown
Tire Brand Series		Wheel	
DOT Left Front		DOT Right Front	
DOT Left Rear		DOT Right Rear	
DOT Left Inner		DOT Right Inner	
DOT Spare			

Vehicle Information			
VIN	4F2YU06152K	Engine Serial Number	003331086
Model Year	2002	Engine Description	3.0L DOHC EGI V6 NA*GAS
Transmission	4 SPD AUTO TRANS MAZDA CD4E	Vehicle Description	TRIBUTE
Body Cab Style	CA WE 5 DOOR LIGHT TRUCK	Drive Line	4 WHL L/H PART TIME DRIVE
Production Date	31-Jul-2001	Retail Sale Indicator Code	
Plant Description	KANSAS CITY PLANT BUILD	Required Vehicle	
Build Region		Warranty Start Date	07-Oct-2001
Build Country Code		Transmission Serial Number	
Mileage	89000	Vehicle Axle Ratio	

Disclaimer:

This data is for use as one of several potential "awareness" indicators for the Ford Motor Co. Enhanced Concern Identification System. It is unverified, draft, summary data generated from a computer "word search" of customer and technician symptom comments. Supplier data, technician and customer comments are unverified and actual root cause of any potential issue is not established by this summary.

[Contact CDR HELP](#)

Copyright 2001 Ford Motor Co All Rights Reserved

PE12-019

Mazda

9-6-2012

REQUEST NUMBER THREE
DOCUMENTS (SUBJECT)

Consumer Reports

Mazda CAC

ECI

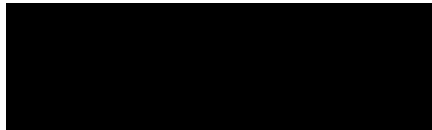



Concern Driven Reporting

Report Detail

Note: Field which are grayed (ghosted) are currently being mapped to the data warehouse. They are not presently being populated.

ECI Record		Source Code	MAZDA CAC
------------	--	-------------	-----------

Commodity Assignment			
Commodity	powertrain-engine	Symptom	field service action
Commodity	powertrain-engine	Symptom	function-malfunction/inoperative
Commodity	powertrain-engine	Symptom	mod-driving condition-while towing
Commodity	powertrain-engine	Symptom	no keyword found
Commodity	powertrain-engine-accel pedal/linkage/controls	Symptom	field service action
Commodity	powertrain-engine-accel pedal/linkage/controls	Symptom	function-malfunction/inoperative
Commodity	powertrain-engine-accel pedal/linkage/controls	Symptom	mod-vehicle towed in
Commodity	powertrain-engine-accel pedal/linkage/controls	Symptom	sticks/binds/grabs
Commodity	powertrain-engine-air induction-throttle body-	Symptom	field service action
Commodity	powertrain-engine-air induction-throttle body-	Symptom	function-malfunction/inoperative
Significant Event		Verified	N

Tread Information	
Reported in Tread Quarter	Q4 2009

Report Details			
Source Claim Key		Warranty Component Classification (WCC)	
Corporate Product Systems Classification (CPSC)		Time in Service	80
Customer Condition Code		V Function Group (VFG)	
Source System Program Type		Repair/Report/Paid Date	07-Dec-2009
Version Series Code	AAAA5	Load Date	13-Dec-2009
Causal Part Prefix-Base-Suffix	--	Dealer Code	34648
Causal Part Name	unknown	Dealer Name	RAY BRANDT MAZDA
Non Causal Part Prefix-Base-Suffix		Dealer City	HARVEY
Non Causal Part Numbers		Dealer State/Province	LA
Fault Code		Dealer Country	USA
Diagnostic Trouble Code		Dealer Phone Number	5043631405
Labor Operation Code		Attachment	
Communication Type		VOQ Component Description Code	
Maintenance Date	13-Dec-2009		

Customer Comment: CUSTOMER STATES THROTTLE CABLE IS STUCK, AND HE THINKS IT IS RELATED TO OPEN RECALL 2704L. OR: CUSTOMER IS AT WORK LOCATION GRETNA LA 7

Technician Comment: ADVISED CUSTOMER PER KEITH AT DEALER, FAILURE IS UNRELATED TO RECALL, HOWEVER THEY WILL BE PERFORMING RECALL FOR CUSTOMER. CUSTOMER DISAGREES THAT FAILURE IS UNRELATED AND MAY CONTACT ATTORNEY. ADVISED CUSTOMER DEALER WILL BE MORE THAN HAPPY TO EXPLAIN FAILURE IN MORE DETAIL AS THIS OFFICE IS NOT TECHNICALLY TRAINED. 0012009 12 07CRPP229 REQ DESC RECALL INQUIRY/THROTTLE CABLE STUCK PLACED CUSTOMER ON HOLD AND SPOKE WITH SUPERVISOR REGARDING AUTHORIZING TOW AS CUSTOMERS FEELS FAILURE IS RELATED TO OPEN RECALL. ADVISED RECEIVED ADDRESS OF WHERE CUSTOMER IS LOCATED, AND STATED WILL BE CALLING ROADSIDE ASSISTANCE TO AUTHORIZE FREE TOW TO CLOSEST DEALER. CALLED CUSTOMER WHO STATED HE HAS NOT HEARD FROM RSA YET. INFORMED HIM AGENT SPOKE WITH DARALYN AT RSA, WHO INFORMED AGENT SHE WILL BE CALLING CUSTOMER AT TWO NUMBERS PROVIDED. ADV 0022009 12 07CRPP229 ISED GAVE RSA ADDRESS TO WHERE VEHICLE IS AND AUTHORIZED FREE TOW. ADVISED ONCE VEHICLE IS AT DEALER, THEY WILL BE ABLE TO DETERMIN IF PROBLEM FALLS UNDER RECALL OR NOT. GAVE CUSTOMER DIRECT CONTACT INFO IF HE DOES NOT HEAR FROM ROADSIDE ASSISTANCE TO CALL. WILL LEAVE OPEN FOR THE DAY. 0032009 12 08CRPP104 CUSTOMER CALLED FOR AGENT, TRANSFERRED CALL 0042009 12 08CRPP229 CUSTOMER STATES EVENTHOUGH PART SHOULD BE COVERED BECAUSE OF RECALL. DEALER HAS SAID THERE IS A CHARGE. AGENT ADVISED MAZDA WILL ONLY BE ABLE TO ASSIST WITH PERFORMING RECALL. ADVISED IF DEALER HAS DETERMINED FAILURE IS UNRELATED TO RECALL, THEN IT WOULD BE CUSTOMER PAY. ADVISED CUSTOMER AGENT WILL CONTACT DEALER FOR FURTHER CLARIFICATION. LEFT MESSAGE FOR KEITH IN SERVICE FOR EXPLANATION. SPOKE WITH KEITH AT DEALER. STATES THROTTLE BODY HAS FAILED WHICH IS COMPLETELY UNRELATED TO OPEN RECALL. STATES THEY WI 0052009 12 08CRPP229 LL BE COMPLETING RECALL FOR CUSTOMER. ADVISED CUSTOMER PER KEITH AT DEALER, FAILURE IS UNRELATED TO RECALL, HOWEVER THEY WILL BE PERFORMING RECALL FOR CUSTOMER. CUSTOMER DISAGREES THAT FAILURE IS UNRELATED AND MAY CONTACT ATTORNEY. ADVISED CUSTOMER DEALER WILL BE MORE THAN HAPPY TO EXPLAIN FAILURE IN MORE DETAIL AS THIS OFFICE IS NOT TECHNICALLY TRAINED.

CQIS Recommendations:

Tire Information			
Tire Manufacturer	Unknown	Tire Size	Unknown
Tire Brand Series		Wheel	
DOT Left Front		DOT Right Front	
DOT Left Rear		DOT Right Rear	
DOT Left Inner		DOT Right Inner	
DOT Spare			

Vehicle Information

VIN	4F2YZ04133K [REDACTED]	Engine Serial Number	
Model Year	2003	Engine Description	3.0L DOHC EGI V6 NA*G DSP2967
Transmission	4 SPD AUTO TRANS MAZDA CD4E	Vehicle Description	TRIBUTE
Body Cab Style	CA WE 5 DOOR LIGHT TRUCK	Drive Line	2 WHL L/H FRONT DRIVE
Production Date	02-Dec-2002	Retail Sale Indicator Code	
Plant Description	KANSAS CITY PLANT BUILD	Required Vehicle	
Build Region		Warranty Start Date	11-Jun-2003
Build Country Code		Transmission Serial Number	
Mileage	130000	Vehicle Axle Ratio	
Vehicle Restraint Code			

Disclaimer:

This data is for use as one of several potential "awareness" indicators for the Ford Motor Co. Enhanced Concern Identification System. It is unverified, draft, summary data generated from a computer "word search" of customer and technician symptom comments. Supplier data, technician and customer comments are unverified and actual root cause of any potential issue is not established by this summary.

[Contact CDR HELP](#)
 Copyright 2001 Ford Motor Co All Rights Reserved

PE12-019

Mazda

9-6-2012

REQUEST NUMBER THREE
DOCUMENTS (SUBJECT)

Consumer Reports

Mazda CAC

ECI

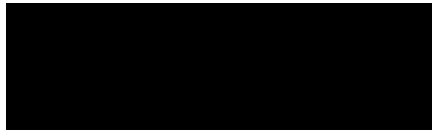



Concern Driven Reporting

Report Detail

Note: Field which are grayed (ghosted) are currently being mapped to the data warehouse. They are not presently being populated.

ECI Record		Source Code	MAZDA CAC
------------	--	-------------	-----------

Commodity Assignment			
Commodity	powertrain-engine	Symptom	administrative cost
Commodity	powertrain-engine	Symptom	function-malfunction/inoperative
Commodity	powertrain-engine	Symptom	high effort
Commodity	powertrain-engine	Symptom	no keyword found
Commodity	powertrain-engine	Symptom	pedal concerns-accelerator pedal
Commodity	powertrain-engine	Symptom	repair-prior repair mentioned
Commodity	powertrain-engine	Symptom	separation
Commodity	powertrain-engine	Symptom	sticks/binds/grabs
Commodity	powertrain-engine-accel pedal/linkage/controls	Symptom	no keyword found
Commodity	powertrain-engine-air induction-throttle body-	Symptom	no keyword found
Significant Event		Verified	N

Tread Information	
Reported in Tread Quarter	Q4 2009

Report Details			
Source Claim Key		Warranty Component Classification (WCC)	
Corporate Product Systems Classification (CPSC)		Time in Service	57
Customer Condition Code		V Function Group (VFG)	
Source System Program Type		Repair/Report/Paid Date	08-Dec-2009
Version Series Code	AAAGH	Load Date	13-Dec-2009
Causal Part Prefix-Base-Suffix	--	Dealer Code	34581
Causal Part Name	unknown	Dealer Name	BOMMARITO MAZDA SOUTH
Non Causal Part Prefix-Base-Suffix		Dealer City	SAINT LOUIS
Non Causal Part Numbers		Dealer State/Province	MO
Fault Code		Dealer Country	USA
Diagonstic Trouble Code		Dealer Phone Number	3144879800
Labor Operation Code		Attachment	
Communication Type		VOQ Component Description Code	
Maintenance Date	13-Dec-2009		

Customer Comment CUSTOMER STATES ACCELERATOR IS STUCK AND WILL NOT GO DOWN TO PROVIDE GAS, THIS HAS JUST HAPPEN ONCE SINCE THE REPAIR IN NOVEMBER 2007 WHERE THE ACCELERATOR WAS STUCK ACCELERATING VEHICLE WHILE DRIVING. CUSTOMER STATES VEHICLE IS OUT OF WARRANTY AND WOULD LIKE MNAO TO ASSIST WITH REPAIR VEHICLE IS NOT AT A MAZDA DEALER

Technician Comment AGENT CONFERENCE CALL CUSTOMER & SERVICE ADVISOR GREG BAMBERG OF DEALER # 34581. AGENT EXPLAINED TO DEALER CUSTOMER TO PAY FOR INSPECTION AND AWA WILL BE CONSIDERED. DEALER AND CUSTOMER GIVEN FILE # AND AGENTS CONTACT # 0012009 12 08CRPP235 REQ DESC AWA CUSTOMER ADVISED THERE ARE NO RECALLS FOR THIS PROBLEM AND AWA CANNOT BE CONSIDERED UNTIL A VEHICLE IS INSPECTED BY A MAZDA DEALER AND CUSTOMER IS RESPONSIBLE TO PAY FOR INSPECTION. AGENT ADVISED CUSTOMER THERE IS NO GUARANTEE OF ASSISTANCE, BUT AGENT WILL CONSIDER AGENT CONFERENCE CALL CUSTOMER & SERVICE ADVISOR GREG BAMBERG OF DEALER # 34581. AGENT EXPLAINED TO DEALER CUSTOMER TO PAY FOR INSPECTION AND AWA WILL BE CONSIDERED. DEALER AND C 0022009 12 08CRPP235 USTOMER GIVEN FILE # AND AGENTS CONTACT # [REDACTED] 12 09CRPP235 CUSTOMER LEFT VOICE MAIL STATING SHE WAS OFFERED A 50/50 SPLIT FOR THE REPAIR TO THROTTLE AND UNDERSTANDS THE VEHICLE IS OUT OF WARRANTY. CUSTOMER CALLED TO EXPRESS CONCERN THAT SHE BELIEVES THE REPAIR DONE TWO YEARS AGO WAS NOT DONE PROPERLY AND THIS IS NOW CAUSING MONEY TO COME OUT OF HER POCKET. CUSTOMER STATES SHE NOT HAPPY A LOANER VEHICLE WAS NOT PROVIDED, AND SHE IS NOT SURE SHE WILL RETURN TO MAZDA DUE TO THE LEVEL OF CUSTOMER SERVICE SHE HAS RECEIVED. AGENT CONTACTED SERVICE ADVISOR GREG BAMBERG TO REVIEW WHAT WAS APPROVED F 0042009 12 09CRPP235 OR ASSISTANCE AND BY WHOM. GREG INDICATES THE REPAIR IS FOR THE THROTTLE BODY AND SAME REPAIR THAT WAS COMPLETED UNDER WARRANTY 11/2007. DEALER CONTACTED THE DSM WHO APPROVED A 50/50 SPLIT AND PRICING SET AT WARRANTY PRICING. CUSTOMER TO PAY ESTIMATED \$92 AND RETAIL PRICE WOULD HAVE BEEN \$380. GREG STATES HE ATTEMPTED TO CONTACT CUSTOMER TODAY TO UPDATE HER PORTION WAS LOWER THAN YESTERDAYS QUOTE OF \$160. GREG STATES CUSTOMER WAS PLEASED YESTERDAY WITH THE ASSISTANCE THAT WAS BEING PROVIDED. AGENT ADVISED THAT CUSTOMER HAS CALLED L 0052009 12 09CRPP235 EAVING VOICE EXPRESSING HER DISSATISFACTION WITH THE 50/50 SPLIT, BUT AGENT WILL CALL CUSTOMER TO ADDRESS HER CONCERNS AGENT HAS LEFT 2 MESSAGES TODAY AT REQUESTED CALL BACK # [REDACTED] CUSTOMER CALLED BACK AGENT EXPLAINED WHO AND WHY THE OFFER OF GOODWILL ASSISTANCE WAS MADE AND WHY A RENTAL OR LOANER CAR WOULD NOT BE PROVIDED. CUSTOMER THANKED AGENT FOR HIS ASSISTANCE

CQIS Recommendation	
---------------------	--

Tire Information			
Tire Manufacturer	Unknown	Tire Size	Unknown
Tire Brand Series		Wheel	
DOT Left Front		DOT Right Front	
DOT Left Rear		DOT Right Rear	
DOT Left Inner		DOT Right Inner	

DOT Spare			
Vehicle Information			
VIN	4F2YZ02Z25K	Engine Serial Number	
Model Year	2005	Engine Description	2.3L DOHC EGI I4 16V NA GAS
Transmission	4 SPD AUTO TRANS MAZDA CD4E	Vehicle Description	TRIBUTE
Body Cab Style	CA WE 5 DOOR LIGHT TRUCK	Drive Line	2 WHL L/H FRONT DRIVE
Production Date	05-Apr-2005	Retail Sale Indicator Code	
Plant Description	KANSAS CITY PLANT BUILD	Required Vehicle	
Build Region		Warranty Start Date	23-Apr-2005
Build Country Code		Transmission Serial Number	
Mileage	50150	Vehicle Axle Ratio	
Vehicle Restraint Code			

Disclaimer:

This data is for use as one of several potential "awareness" indicators for the Ford Motor Co. Enhanced Concern Identification System. It is unverified, draft, summary data generated from a computer "word search" of customer and technician symptom comments. Supplier data, technician and customer comments are unverified and actual root cause of any potential issue is not established by this summary.

[Contact CDR HELP](#)
 Copyright 2001 Ford Motor Co. All Rights Reserved

PE12-019

Mazda

9-6-2012

REQUEST NUMBER THREE
DOCUMENTS (SUBJECT)

Consumer Reports

Mazda CAC

ECI

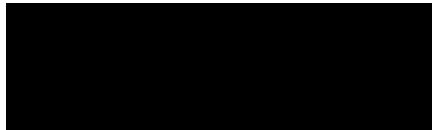



Concern Driven Reporting

Report Detail

Note: Field which are grayed (ghosted) are currently being mapped to the data warehouse. They are not presently being populated.

ECI Record		Source Code	MAZDA CAC
------------	--	-------------	-----------

Commodity Assignment

Commodity	Symptom	Administrative Cost
powertrain-engine—	powertrain-engine—	administrative cost
powertrain-engine—	powertrain-engine—	no keyword found
powertrain-engine-accel pedal/linkage/controls—	powertrain-engine-accel pedal/linkage/controls—	administrative cost
powertrain-engine-accel pedal/linkage/controls—	powertrain-engine-accel pedal/linkage/controls—	high effort
powertrain-engine-accel pedal/linkage/controls—	powertrain-engine-accel pedal/linkage/controls—	mod-driving condition-on acceleration
powertrain-engine-accel pedal/linkage/controls—	powertrain-engine-accel pedal/linkage/controls—	mod-driving condition-while driving
powertrain-engine-accel pedal/linkage/controls—	powertrain-engine-accel pedal/linkage/controls—	no keyword found
powertrain-engine-accel pedal/linkage/controls—	powertrain-engine-accel pedal/linkage/controls—	pedal concerns-accelerator pedal
powertrain-engine-accel pedal/linkage/controls—	powertrain-engine-accel pedal/linkage/controls—	repair-prior repair mentioned
powertrain-engine-accel pedal/linkage/controls—	powertrain-engine-accel pedal/linkage/controls—	sticks/binds/grabs
powertrain-engine-air induction-throttle body-	powertrain-engine-air induction-throttle body-	no keyword found
powertrain-engine-fuel system—	powertrain-engine-fuel system—	repair-prior repair mentioned
powertrain-engine-fuel system—	powertrain-engine-fuel system—	sticks/binds/grabs
Significant Event	Verified	N

Tread Information

Reported in Tread Quarter	Q4 2009
---------------------------	---------

Report Details

Source Claim Key	Warranty Component Classification (WCC)
Corporate Product Systems Classification (CPSC)	Time in Service
Customer Condition Code	V Function Group (VFG)
Source System Program Type	Repair/Report/Paid Date
Version Series Code	Load Date
Causal Part Prefix- Base - Suffix	Dealer Code
Causal Part Name	Dealer Name
Non Causal Part Prefix-Base-Suffix	Dealer City
Non Causal Part Numbers	Dealer State/Province
Fault Code	Dealer Country
Diagnosis Trouble Code	Dealer Phone Number
Labor Operation Code	Attachment
Communication Type	VOQ Component Description Code
Maintenance Date	21-Dec-2009

Customer Comment: CUSTOMER STATES THAT HER VEHICLE HAS BEEN IN THE DEALERSHIP MULTIPLE TIME FOR THE SAME CONCERN REGARDING THE THROTTLE STICKING. CUSTOMER STATES THE DEALERSHIP HAS MADE MULTIPLE REPAIRS TO FIX THE CONCERN, AND NOTHING HAS FIXED IT YET. STATES THE DEALERSHIP IS RECOMMENDING FUEL INJECTION SERVICE. WOULD LIKE MAZDA TO ASSIST IN MAKING SURE THE CONCERN IS ADDRESSED.

Technician Comment: ATTN DCSM/SVM PLEASE REVIEW CUSTOMER REQUEST. CUSTOMER HAS HAD VEHICLE AT DEALERSHIP MULTIPLE TIMES FOR THE SAME CONCERN. CUSTOMER STATES THE VEHICLE IS STILL HAVING THE SAME ISSUE UPON DELIVERY. WOULD LIKE MAZDA TO ASSIST IN REPAIRING THE VEHICLE AND TO PROVIDE A RENTAL IF POSSIBLE. REPLACED THROTTLE BODY 0012009 12 08CRPC325 AT ATTN DCSM/SVM PLEASE REVIEW CUSTOMER REQUEST. CUSTOMER HAS HAD VEHICLE AT DEALERSHIP MULTIPLE TIMES FOR THE SAME CONCERN. CUSTOMER STATES THE VEHICLE IS STILL HAVING THE SAME ISSUE UPON DELIVERY. WOULD LIKE MAZDA TO ASSIST IN REPAIRING THE VEHICLE AND TO PROVIDE A RENTAL IF POSSIBLE. REQ DESC THROTTLE STICKS / HARD ACCELERATION AGENT ADVISED THE CUSTOMER THAT I WOULD LIKE TO CONTACT THE DEALERSHIP AND ALSO THE DSM TO GET MORE INFORMATION ON HOW WE CAN ASSIST. CUSTOMER UNDERSTOOD. 0022009 12 08CRPC325 AGENT CONTACTED THE DEALERSHIP AND SPOKE WITH HENRY IN SERVICE. HENRY ADVISED THAT THEY REPLACED THE GAS PEDAL AND ALL THE WIRINGS, AND THEY FOUND NO ISSUE WITH THE VEHICLE WHEN THEY TEST DROVE IT. ADVISED THAT IF THE CUSTOMER IS STILL CONTINUING TO EXPERIENCE THE CONCERNS, SHE NEEDS TO BRING THE VEHICLE IN TO THE DEALERSHIP. AGENT SENT AN EMAIL MESSAGE WITH CUSTOMER REQUEST TO DSM DAN. AWAITING REPLY 0032009 12 14CRPC325 AGENT CONTACTED THE CUSTOMER. CUSTOMER STATES THAT THE DEALERSHIP DIAGNOSED THE CONCERN, AND REPAIRED THE ISSUE. CUSTOMER THANKED ME FOR MY HELP AND TIME, AND STATES THAT SHE WAS VERY APPRECIATIVE FOR OUR INTERVENTION. AGENT THANKED CUSTOMER. CUSTOMER REQUEST RESOLVED. AWAITING FILE CLOSURE BY DEALERSHIP OR DSM. 0042009 12 16CRPC325 REPLACED THROTTLE BODY

CQIS Recommendations	
----------------------	--

Tire Information

Tire Manufacturer	Tire Size
Unknown	P235/70R 16T BSW A S
Tire Brand Series	Wheel
DOT Left Front	DOT Right Front
DOT Left Rear	DOT Right Rear
DOT Left Inner	DOT Right Inner
DOT Spare	

Vehicle Information

VIN	4F2CZ92Z48K	Engine Serial Number	191207I02801
Model Year	2008	Engine Description	2.3L 4V DOHC EFI NA I4 GAS
Transmission	4 SPD AUTO TRANS NAAO CD4E	Vehicle Description	TRIBUTE
Body Cab Style	Unknown	Drive Line	4 WHL L/H FULL TIME DRIVE
Production Date	14-Jan-2008	Retail Sale Indicator Code	
Plant Description	KANSAS CITY PLANT BUILD	Required Vehicle	
Build Region		Warranty Start Date	28-Feb-2008
Build Country Code		Transmission Serial Number	010880040385
Mileage	22000	Vehicle Axle Ratio	
Vehicle Restraint Code			

Disclaimer:

This data is for use as one of several potential "awareness" indicators for the Ford Motor Co. Enhanced Concern Identification System. It is unverified, draft, summary data generated from a computer "word search" of customer and technician symptom comments. Supplier data, technician and customer comments are unverified and actual root cause of any potential issue is not established by this summary.

[Contact CDR HELP](#)
 Copyright 2001 Ford Motor Co All Rights Reserved

PE12-019

Mazda

9-6-2012

REQUEST NUMBER THREE
DOCUMENTS (SUBJECT)

Consumer Reports

Mazda CAC

ECI

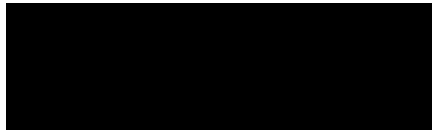



Concern Driven Reporting

Report Detail

Note: Field which are grayed (ghosted) are currently being mapped to the data warehouse. They are not presently being populated.

ECI Record		Source Code	MAZDA CAC
------------	--	-------------	-----------

Commodity Assignment			
Commodity	powertrain-engine—	Symptom	no keyword found
Commodity	powertrain-engine-accel pedal/linkage/controls—	Symptom	pedal concerns-accelerator pedal
Commodity	powertrain-engine-accel pedal/linkage/controls—	Symptom	sticks/binds/grabs
Commodity	powertrain-engine-air induction-throttle body-	Symptom	sticks/binds/grabs
Commodity	powertrain-engine-miscellaneous controls—	Symptom	no keyword found
Commodity	powertrain-engine-miscellaneous controls—	Symptom	sticks/binds/grabs
Significant Event		Verified	N

Tread Information	
Reported in Tread Quarter	Q4 2009

Report Details			
Source Claim Key		Warranty Component Classification (WCC)	
Corporate Product Systems Classification (CPSC)		Time in Service	
Customer Condition Code		V Function Group (VFG)	
Source System Program Type		Repair/Report/Paid Date	21-Dec-2009
Version Series Code	AAAGH	Load Date	29-Dec-2009
Causal Part Prefix- Base - Suffix	- -	Dealer Code	UNKNOW
Causal Part Name	unknown	Dealer Name	
Non Causal Part Prefix-Base-Suffix		Dealer City	
Non Causal Part Numbers		Dealer State/Province	
Fault Code		Dealer Country	USA
Diagonstic Trouble Code		Dealer Phone Number	
Labor Operation Code		Attachment	
Communication Type		VOQ Component Description Code	
Maintenance Date	29-Dec-2009		

Customer Comment	CUSTOMER STATES THE ACCELERATOR GETS STUCK AND THEN POWER IS GIVEN AFTER A DELAY. THE FORD DEALER HAS ADVISED A VALVE IN A THROTTLE BODY FLAP IS GETTING STUCK AND NEEDS TO BE CLEAN. THIS HAS OCCURRED 3 TIMES, EVERY 30K. CUSTOMER INQUIRED WHAT CAN BE DONE		
Technician Comment	AGENT ADVISED NO RECALLS AND AGENT RECOMMEND THANKING VEHICLE TO MAZDA DEALER FOR INSPECTION 0012009 12 21CRPP235 REQ DESC THROTTLE VALVE AGENT ADVISED NO RECALLS AND AGENT RECOMMEND THANKING VEHICLE TO MAZDA DEALER FOR INSPECTION		
CQIS Recommendations			

Tire Information			
Tire Manufacturer	Unknown	Tire Size	Unknown
Tire Brand Series		Wheel	
DOT Left Front		DOT Right Front	
DOT Left Rear		DOT Right Rear	
DOT Left Inner		DOT Right Inner	
DOT Spare			

Vehicle Information			
VIN	4F2YZ0Z26K	Engine Serial Number	290705234215
Model Year	2006	Engine Description	2.3L DOHC EGI I4 16V NA GAS
Transmission	4 SPD AUTO TRANS MAZDA CD4E	Vehicle Description	TRIBUTE
Body Cab Style	CA WE 5 DOOR LIGHT TRUCK	Drive Line	2 WHL L/H FRONT DRIVE
Production Date	11-Aug-2005	Retail Sale Indicator Code	
Plant Description	KANSAS CITY PLANT BUILD	Reaquired Vehicle	
Build Region		Warranty Start Date	
Build Country Code		Transmission Serial Number	
Mileage	73000	Vehicle Axle Ratio	
Vehicle Restraint Code			

Disclaimer:

This data is for use as one of several potential "awareness" indicators for the Ford Motor Co. Enhanced Concern Identification System. It is unverified, draft, summary data generated from a computer "word search" of customer and technician symptom comments. Supplier data, technician and customer comments are unverified and actual root cause of any potential issue is not established by this summary.

[Contact ODRHELP](#)

Copyright 2001 Ford Motor Co All Rights Reserved

PE12-019

Mazda

9-6-2012

REQUEST NUMBER THREE
DOCUMENTS (SUBJECT)

Consumer Reports

Mazda CAC

ECI

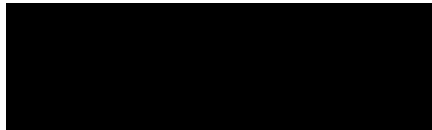



Concern Driven Reporting

Report Detail

Note: Field which are grayed (ghosted) are currently being mapped to the data warehouse. They are not presently being populated.

ECI Record		Source Code	MAZDA CAC
------------	--	-------------	-----------

Commodity Assignment			
Commodity	powertrain-engine	Symptom	administrative cost
Commodity	powertrain-engine	Symptom	damage
Commodity	powertrain-engine	Symptom	field service action
Commodity	powertrain-engine	Symptom	function-malfunction/inoperative
Commodity	powertrain-engine	Symptom	mod-pre delivery
Commodity	powertrain-engine	Symptom	no keyword found
Commodity	powertrain-engine	Symptom	repair-prior repair mentioned
Commodity	powertrain-engine	Symptom	start-will not start
Commodity	powertrain-engine-accel pedal/linkage/controls	Symptom	function-malfunction/inoperative
Commodity	powertrain-engine-air induction-throttle body-	Symptom	function-malfunction/inoperative
Significant Event		Verified	N

Tread Information	
Reported in Tread Quarter	Q4 2009

Report Details			
Source Claim Key		Warranty Component Classification (WCC)	
Corporate Product Systems Classification (CPSC)		Time in Service	38
Customer Condition Code		V Function Group (VFG)	
Source System Program Type		Repair/Report/Paid Date	23-Oct-2009
Version Series Code		Load Date	06-Jan-2010
Causal Part Prefix- Base - Suffix	--	Dealer Code	34554
Causal Part Name	unknown	Dealer Name	NORTH POINT MAZDA
Non Causal Part Prefix-Base-Suffix		Dealer City	SHERWOOD
Non Causal Part Numbers		Dealer State/Province	AR
Fault Code		Dealer Country	USA
Diagonstic Trouble Code		Dealer Phone Number	5019455353
Labor Operation Code		Attachment	
Communication Type		VOQ Component Description Code	
Maintenance Date	27-Dec-2010		

Customer Comment	LOG NO 2029 NO START, HIGH IDLE ON 10/23/09 RCVD ATTY LTR FROM ANIBLE & EDWARDS. STS REPRESENTS CUST PURSUANT TO THE AR NEW MOTOR VEH QUALITY ASSURANCE ACT. CUST CONTACTED CUSTOMER MEDIATION & BBB BACK IN JUNE 2008 SEEKING REPURCHASE. STS CUST IS STILL EXPERIENCING SAME CONCERNS WITH TRANSMISSION & ENGINE AS BEFORE. CUSTOMER MEDIATION HANDLING CHARLIE KIM
------------------	---

Technician Comment
CORPORATE REPURCHASE DUE TO MULTIPLE REPAIRS. REPLACED ALTERNATOR, TRANSMISSION, THROTTLE BODY. RCVD CONFIRMATION FROM VANESSA YU IN FINANCE THAT WIRED FUNDS WERE RCVD FROM RIVERSIDE AUTO AUCTION ON 12/21/10 FROM SALE OF VEHICLE 0012009 10 23CRPC408 REQ DESC ATTY LEMON LAW DEMAND 0022009 10 28CRPC408 SENT EMAIL TO ATTORNEY. ADVISED OF ORIGINAL IN SERVICE DATE. ADVISED WE HAVE COPY OF SALES CONTRACT FROM ORIGINAL OWNER. ADVISED MAZDA WILL OFFER \$2500, INCLUSIVE OF ATTORNEY FEES. 0032009 10 30CRPC408 RECEIVED EMAIL FROM ATTORNEY. ATTORNEY INQUIRING IF MAZDA WILL CONSIDER REPURCHASING THE VEHICLE. CALLED AND SPOKE WITH ATTORNEY. ADVISED MAZDA HAS NOT PRECLUDED THE POSSIBILITY OF REPURCHASE AS AN OPTION IF NECESSARY. ATTORNEY STATES WILL REVIEW OFFER WITH CLIENT AND CALL ME BACK. 0042009 11 20CRPC408 RECEIVED EMAIL FROM ATTORNEY DEAR MR. KIM,I UNDERSTAND THAT MAZDA USA WILL INDEMNIFY NORTH POINT MAZDA WITH RESPECT TO ITS LIABILITY IN THIS MATTER. I HAVE CONSULTED WITH MY CLIENT REGARDING YOUR REQUEST FOR A SETTLEMENT COUNTER OFFER. MY CLIENT STANDS FIRM ON HER ORIGINAL DEMAND. THE AMOUNT OF MY CLIENT'S DEMAND IS \$28,151.18 AND INCLUDES MAZDA USA REPURCHASING THE VEHICLE IN QUESTION. THIS AMOUNT WAS COMPUTED BY APPLYING THE DAMAGES PROVISIONS OF THE ARKANSAS NEW MOTOR VEHICLE QUALITY ASSURANCE ACT. THIS ACT EXPLICITLY SETS FO 0052009 11 20CRPC408 RTH THE MANNER IN WHICH DAMAGES SHOULD BE COMPUTED AND PROVIDES FOR AN AWARD OF THE CONSUMER'S ATTORNEY'S FEES. I UNDERSTAND THAT MAZDA USA HAS TAKEN THE POSITION THAT THE VEHICLE IN QUESTION WAS PLACED IN SERVICE PRIOR TO MY CLIENT'S PURCHASE OF SAME AND THAT MY CLIENT IS TIME BARRED FROM BRINGING HER CLAIM. HOWEVER, THIS POSITION IGNORES THE FACTS OF THIS CASE. NORTH POINT MAZDA SOLD THIS VEHICLE TO MY CLIENT AS A NEW VEHICLE. THIS FACT IS DOCUMENTED IN THE SALES PAPERWORK AND IN A LETTER RECEIVED FROM THE GENERAL MANAGER OF NORT 0062009 11 20CRPC408 H POINT MAZDA. THE CLOCK DID NOT BEGIN TICKING WITH RESPECT TO MY CLIENT'S CLAIM UNTIL THE DATE SHE PURCHASED THE VEHICLE. GIVEN THE FACTS OF THIS CASE, THE PROVISIONS OF THE ARKANSAS NEW MOTOR VEHICLE QUALITY ASSURANCE ACT SHOULD APPLY IN THIS CLAIM AND SAID CLAIM HAS BEEN MADE TIMELY REGARDLESS WHETHER THE VEHICLE WAS USED PRIOR TO MY CLIENT'S PURCHASE. ADDITIONALLY, SHOULD A JURY FIND THAT YOUR DEALERSHIP COMMITTED FRAUD IN THE SALE OF THIS VEHICLE TO MY CLIENT, THERE LIES THE POSSIBILITY OF PUNITIVE DAMAGES BEING AWARDED AGAI 0072009 11 20CRPC408 NST NORTH POINT MAZDA.I AM HOPEFUL THAT WE WILL BE ABLE TO RESOLVE THIS MATTER WITHOUT THE NEED OF LITIGATION. I AWAIT YOUR REPLY. SENT EMAIL TO ATTORNEY. ADVISED MAZDA IS WILLING TO SETTLE FOR \$3500.00, INCLUSIVE OF ATTORNEY FEES. ADVISED WE WOULD TAKE FULL USAGE AS PERMITTED BY THE STATE EVEN IF WE HAD TO REPURCHASE THE VEHICLE. ADVISED THEIR CLIENT'S REQUEST FOR \$28,151.18 SETTLEMENT OFFER IS REASONABLE. 0082009 11 25CRPC408 SENT EMAIL TO ATTORNEY. ADVISED MAZDA IS WILLING TO SETTLE FOR \$3500.00, INCLUSIVE OF ATTORNEY FEES. ADVISED WE WOULD TAKE FULL USAGE AS PERMITTED BY THE STATE EVEN IF WE HAD TO REPURCHASE THE VEHICLE. RECVD EMAIL FROM ATTORNEY. STATES THE BREAKDOWN FORMULA FOR THE SETTLEMENT OF \$28,000. SENT EMAIL TO ATTORNEY. ADVISED MAZDA IS WILLING TO OFFER \$6,000.00, INCLUSIVE OF ATTORNEY FEES. 0092009 12 01CRPC408 RECEIVED EMAIL FROM ATTORNEY DEAR MR. KIM,MY CLIENT IS WILLING TO FULLY RESOLVE THIS MATTER BY PAYMENT OF \$26,151.18.I AWAIT YOUR RESPONSE. SENT EMAIL TO ATTORNEY. ADVISED THIS CASE WILL BE FORWARDED TO SENIOR SPECIALIST FOR REVIEW. ADVISED WILL NEED CURRENT REGISTRATION AND LOAN INFO SHOWING PAYOFF AND PAYMENT HISTORY. 0102009 12 08CRPC408 FILE FORWARDED TO SENIOR SPECIALIST, MARIE, FOR REVIEW. 0112010 04 28CRPP939 _____ FROM MARIE MORTENSEN SENT WEDNESDAY, APRIL 28, 2010 3 06 PMTO 'BRUCE ANIBLE'SUBJECT _____ MAZDA REPURCHASE OFFERATTACHED PLEASE FIND OUR OFFER TO REPURCHASE YOUR CLIENTS 2006 TRIBUTE. PLEASE CONTACT ME WITH ANY QUESTIONS. MARIE MORTENSEN SENIOR SPECIALIST, CUSTOMER MEDIATIONMAZDA NORTH AMERICAN OPERATIONS949 727 6380 PHONE949 727 6592 FAXMMORTENS@MAZDAUSA.COM 0122010 04 30CRPP939 RECEIVED SIGNED ACCEPTANCE OF OFFER. SUBMITTED CHECK REQUEST. 0132010 05 24CRPP939 SENT EMAIL TO ATTORNEY REQUESTING A COPY OF THE CURRENT REGISTRATION AS THE REGISTRATION THAT I HAVE EXPIRED IN FEB. 2010. 0142010 05 25CRPP939 RECEIVED CURRENT REGISTRATION, SENT CHECKS AND CONTACT PACKAGE TO ISG. 0152010 06 02CRPP939 ATTORNEY ADVISED HE HAD BEEN CONTACTED BY ISG TODAY. 0162010 06 07CRPC399 VEHICLE TRANSACTION COMPLETED NOTIFICATION THE ABOVE REFERENCED VEHICLE WAS TURNED INTO NORTH POINT MAZDA ON 06/04/2010. THE VEHICLE WAS REPURCHASED FOR 1. MULTIPLE REPAIRS NO START, HIGH IDLE.. 0172010 08 26CRPC399 PER RACHEL AT ISG VEH WAS MOVED TO REPAIRING DEALER FREEMAN MAZDA ON 06/26 0182010 10 29CRPC399 RANDY HATZL SENT FINAL RO'S INDICATING VEH HAS BEEN REPAIRED SENT RACHEL @ ISG AN E MAIL REQUESTING TO SEND VEH TO AUCTION 0192010 12 22CRPC399 RCVD CONFIRMATION FROM VANESSA YU IN FINANCE THAT WIRED FUNDS WERE RCVD FROM RIVERSIDE AUTO AUCTION ON 12/21/10 FROM SALE OF VEHICLE

CQIS Recommendations

Tire Information			
Tire Manufacturer	Unknown	Tire Size	Unknown
Tire Brand Series		Wheel	
DOT Left Front		DOT Right Front	
DOT Left Rear		DOT Right Rear	
DOT Left Inner		DOT Right Inner	
DOT Spare			

Vehicle Information			
VIN	4F2YZ02Z56K _____	Engine Serial Number	070905124726
Model Year	2006	Engine Description	2.3L DOHC EGI I4 16V NA GAS
Transmission	4 SPD AUTO TRANS MAZDA CD4E	Vehicle Description	TRIBUTE
Body Cab Style	Unknown	Drive Line	2 WHL L/H FRONT DRIVE
Production Date	20-Dec-2005	Retail Sale Indicator Code	
Plant Description	KANSAS CITY PLANT BUILD	Required Vehicle	
Build Region		Warranty Start Date	22-Sep-2006
Build Country Code		Transmission Serial Number	
Mileage	39000	Vehicle Axle Ratio	
Vehicle Restraint Code			

Disclaimer:

This data is for use as one of several potential "awareness" indicators for the Ford Motor Co. Enhanced Concern Identification System. It is unverified, draft, summary data generated from a computer "word search" of customer and technician symptom comments. Supplier data, technician and customer comments are unverified and actual root cause of any potential issue is not established by this summary.

[Contact ODRHELP](#)

Copyright 2001 Ford Motor Co All Rights Reserved

PE12-019

Mazda

9-6-2012

REQUEST NUMBER THREE
DOCUMENTS (SUBJECT)

Consumer Reports

Mazda CAC

ECI

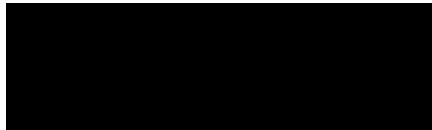



Concern Driven Reporting

Report Detail

Note: Field which are grayed (ghosted) are currently being mapped to the data warehouse. They are not presently being populated.

ECI Record		Source Code	MAZDA CAC
------------	--	-------------	-----------

Commodity Assignment

Commodity	powertrain-engine	Symptom	high effort
Commodity	powertrain-engine	Symptom	no keyword found
Commodity	powertrain-engine	Symptom	pedal concerns-accelerator pedal
Commodity	powertrain-engine	Symptom	sticks/binds/grabs
Commodity	powertrain-engine-accel pedal/linkage/controls	Symptom	high effort
Commodity	powertrain-engine-accel pedal/linkage/controls	Symptom	pedal concerns-accelerator pedal
Commodity	powertrain-engine-accel pedal/linkage/controls	Symptom	sticks/binds/grabs
Significant Event		Verified	N

Tread Information

Reported in Tread Quarter	Q4 2009
---------------------------	---------

Report Details

Source Claim Key		Warranty Component Classification (WCC)	
Corporate Product Systems Classification (CPSC)		Time in Service	61
Customer Condition Code		V Function Group (VFG)	
Source System Program Type		Repair/Report/Paid Date	28-Dec-2009
Version Series Code	AAAGH	Load Date	06-Jan-2010
Causal Part Prefix-Base-Suffix	-	Dealer Code	61454
Causal Part Name	unknown	Dealer Name	RICART MAZDA
Non Causal Part Prefix-Base-Suffix		Dealer City	GROVEPORT
Non Causal Part Numbers		Dealer State/Province	OH
Fault Code		Dealer Country	USA
Diagnostic Trouble Code		Dealer Phone Number	
Labor Operation Code		Attachment	
Communication Type		VOQ Component Description Code	
Maintenance Date	06-Jan-2010		

Customer Comment CUSTOMER STATES THE ACCELERATOR IS STUCK ON HER VEHICLE AND THIS WAS FIXED BACK IN 2006. SEEKING AWA AS IT SHOULD NOT BE HAPPENING AGAIN. STATES SHE CALLED DEALER TO INFORM AND THEY ASKED THAT SHE CALL CAC FOR AWA.

Technician Comment ADVISED CUSTOMER THAT FIRST STEP TO AWA IS TO HAVE VEHICLE DIAGNOSED BY DEALER. ADVISED ONCE THAT IS DONE, DEALER WILL CONTACT DSM FOR AWA CONSIDERATION. ADVISED CUSTOMER AGENT CAN NOT GUARENTEE ASSISTANCE AS WARRANTY HAS EXPIRED. ADVISED SENDING FILE TO DEALER TO INFORM. 0012009 12 28CRPP229 SM *** FYI *** CUSTOMER WAS ADVISED THAT VEHICLE IS OUT OF MMA WARRANTY. PLEASE REVIEW AND ASSIST, IF APPLICABLE. PLEASE CONTACT DSM FOR POSSIBLE AWA PER CUSTOMER REQUEST. THANK YOU|| AMY 949 727 6832 REQ DESC GAS PEDAL STICKING ADVISED CUSTOMER THAT FIRST STEP TO AWA IS TO HAVE VEHICLE DIAGNOSED BY DEALER. ADVISED ONCE THAT IS DONE, DEALER WILL CONTACT DSM FOR AWA CONSIDERATION. ADVISED CUSTOMER AGENT CAN NOT GUARENTEE ASSISTANCE AS WARRANTY HAS EXPIRED. ADVISED S 0022009 12 28CRPP229 ENDING FILE TO DEALER TO INFORM.

CQIS Recommendation

Tire Information

Tire Manufacturer	Unknown	Tire Size	Unknown
Tire Brand Series		Wheel	
DOT Left Front		DOT Right Front	
DOT Left Rear		DOT Right Rear	
DOT Left Inner		DOT Right Inner	
DOT Spare			

Vehicle Information

VIN	4F2YZ02ZX5K	Engine Serial Number	
Model Year	2005	Engine Description	2.3L DOHC EGI I4 16V NA GAS
Transmission	4 SPD AUTO TRANS MAZDA CD4E	Vehicle Description	TRIBUTE
Body Cab Style	CA WE 5 DOOR LIGHT TRUCK	Drive Line	2 WHL L/H FRONT DRIVE
Production Date	08-Sep-2004	Retail Sale Indicator Code	
Plant Description	KANSAS CITY PLANT BUILD	Required Vehicle	
Build Region		Warranty Start Date	19-Jan-2005
Build Country Code		Transmission Serial Number	
Mileage	56500	Vehicle Axle Ratio	
Vehicle Restraint Code			

Disclaimer:

This data is for use as one of several potential "awareness" indicators for the Ford Motor Co. Enhanced Concern Identification System. It is unverified, draft, summary data generated from a computer "word search" of customer and technician symptom comments. Supplier data, technician and customer comments are unverified and actual root cause of any potential issue is not established by this summary.

[Contact ODRHELP](#)

Copyright 2001 Ford Motor Co All Rights Reserved

PE12-019

Mazda

9-6-2012

REQUEST NUMBER THREE
DOCUMENTS (SUBJECT)

Consumer Reports

Mazda CAC

ECI

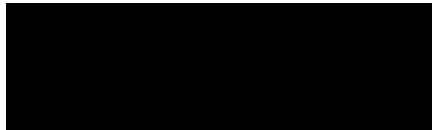



Concern Driven Reporting

Report Detail

Note: Field which are grayed (ghosted) are currently being mapped to the data warehouse. They are not presently being populated.

ECI Record		Source Code	MAZDA CAC
------------	--	-------------	-----------

Commodity Assignment			
Commodity	powertrain-engine	Symptom	function-malfunction/inoperative
Commodity	powertrain-engine	Symptom	mod-aftermarket
Commodity	powertrain-engine	Symptom	mod-weather-cold
Commodity	powertrain-engine	Symptom	no keyword found
Commodity	powertrain-engine	Symptom	no problem found
Commodity	powertrain-engine	Symptom	pedal concerns-accelerator pedal
Commodity	powertrain-engine	Symptom	sticks/binds/grabs
Commodity	powertrain-engine-accel pedal/linkage/controls	Symptom	engine power-loss of power
Commodity	powertrain-engine-accel pedal/linkage/controls	Symptom	function-malfunction/inoperative
Commodity	powertrain-engine-accel pedal/linkage/controls	Symptom	mod-aftermarket
Commodity	powertrain-engine-accel pedal/linkage/controls	Symptom	mod-intermittent/random
Commodity	powertrain-engine-accel pedal/linkage/controls	Symptom	no keyword found
Commodity	powertrain-engine-accel pedal/linkage/controls	Symptom	no problem found
Commodity	powertrain-engine-accel pedal/linkage/controls	Symptom	pedal concerns-accelerator pedal
Commodity	powertrain-engine-accel pedal/linkage/controls	Symptom	sticks/binds/grabs
Commodity	powertrain-engine-air induction-throttle body-	Symptom	engine power-loss of power
Commodity	powertrain-engine-air induction-throttle body-	Symptom	function-malfunction/inoperative
Commodity	powertrain-engine-air induction-throttle body-	Symptom	mod-aftermarket
Commodity	powertrain-engine-air induction-throttle body-	Symptom	mod-intermittent/random
Commodity	powertrain-engine-air induction-throttle body-	Symptom	no keyword found
Commodity	powertrain-engine-air induction-throttle body-	Symptom	no problem found
Commodity	powertrain-engine-air induction-throttle body-	Symptom	sticks/binds/grabs
Significant Event		Verified	N

Tread Information	
Reported in Tread Quarter	Q1 2010

Report Details			
Source Claim Key		Warranty Component Classification (WCC)	
Corporate Product Systems Classification (CPSC)		Time in Service	44
Customer Condition Code		V Function Group (VFG)	
Source System Program Type		Repair/Report/Paid Date	19-Jan-2010
Version Series Code	AAAGH	Load Date	07-Feb-2010
Causal Part Prefix-Base-Suffix	-	Dealer Code	23961
Causal Part Name	unknown	Dealer Name	MAZDA OF NEW BERN
Non Causal Part Prefix-Base-Suffix		Dealer City	NEW BERN
Non Causal Part Numbers		Dealer State/Province	NC
Fault Code		Dealer Country	USA
Diagnostic Trouble Code		Dealer Phone Number	2526336161
Labor Operation Code		Attachment	
Communication Type		VOQ Component Description Code	
Maintenance Date	07-Feb-2010		

Customer Comment	CUSTOMER STATES THAT IN THE COLD WEATHER THEY HAVE PROBLEMS WITH THE ACCELERATOR GETTING STUCK. STATES YOU PUSH ON THE ACCELERATOR AND NOTHING HAPPENS. STATES HE HAS HAD HIS VEHICLE AT THE DEALERSHIP MULTIPLE TIMES FOR THE SAME CONCERN. STATES WOULD LIKE MAZDA TO ASSIST IN FIXING THE VEHICLE. CELL [REDACTED]
------------------	---

Technician Comment
 ATTN DCSM/SVM PLEASE REVIEW CUSTOMER REQUEST. CUSTOMER STATES ACCELERATOR GETS STUCK AND PREVENTS FURTHER ACCELERATION AT RANDOM TIMES. DEALERSHIP IS RECOMMENDING NEW THROTTLE BODY TO ADDRESS CONCERNS. CUSTOMER IS OUTSIDE WARRANTY AND IS REQUESTING MAZDA PROVIDE AWA FOR THIS REPAIR. PLEASE REVIEW AND CLOSE OUT FILE UPON RESOLUTION WITH THE CUSTOM NPF AT TIME OF SERVICE. VEHICLE FOUND TO HAVE AFTERMARKET FLOORMATS, ADVISE CUSTOMER TO REMOVE AFTERMARKET FLOORMATS TO CORRECT CONCERN. IF PROBLEM IS STILL PRESENT TO RETURN BACK TO THE DEALERSHIP FOR FURTHER INSPECTION. 0012010 01 19CRPC325 AT ATTN DCSM/SVM PLEASE REVIEW CUSTOMER REQUEST. CUSTOMER STATES ACCELERATOR GETS STUCK AND PREVENTS FURTHER ACCELERATION AT RANDOM TIMES. DEALERSHIP IS RECOMMENDING NEW THROTTLE BODY TO ADDRESS CONCERNS. CUSTOMER IS OUTSIDE WARRANTY AND IS REQUESTING MAZDA PROVIDE AWA FOR THIS REPAIR. PLEASE REVIEW AND CLOSE OUT FILE UPON RESOLUTION WITH THE CUSTOM0000 N0REQ DESC POOR ACCELERATION AGENT ADVISED THE CUSTOMER THAT I WOULD LIKE TO CALL THE DEALERSHIP TO FIND OUT MORE ABOUT THE REPAIRS NEEDED TO THE VEH 0022010 01 19CRPC325 ICLE. CUSTOMER UNDERSTOOD AND PROVIDED CONTACT INFORMATION. AGENT ADVISED THE CUSTOMER THAT I WOULD CONTACT BACK WITH AN UPDATE ONCE THE DEALERSHIP AND DSM HAD BEEN CONTACTED. AGENT CONTACTED THE DEALERSHIP (252) 633 6161 MAZDA OF NEW BERN, AND SPOKE WITH CHRISTINE IN SERVICE. CHRISTINE ADVISED THAT THEY ARE RECOMMENDING A NEW THROTTLE BODY FOR THE VEHICLE TO ADDRESS THE CONCERNS. CHRISTINE ADVISED THE DEALERSHIP HAS BEEN UNABLE TO REPLICATE THE STICKING ISSUE WITH THE ACCELERATOR, BUT FEEL THE THROTTLE BODY WOULD ADDRESS THE CONC 0032010 01 19CRPC325 ERN. DEALERSHIP ADVISED CUSTOMER IS SEEKING AWA FROM MAZDA FOR THIS REPAIR SINCE HE IS OUTSIDE OF WARRANTY. AGENT SENT EMAIL MESSAGE TO DSM IN THE REGION WITH CUSTOMER'S REQUEST. AWAITING REPLY FOR FURTHER INSTRUCTION. AGENT CONTACTED THE CUSTOMER AND ADVISED THAT THE DEALERSHIP HAD BEEN CONTACTED ABOUT THE SITUATION. ADVISED THEY WILL BE IN CONTACT WITH THEIR DSM FOR POSSIBLE AWA FROM MAZDA FOR THE THROTTLE BODY CONCERN. CUSTOMER UNDERSTOOD. AGENT ADVISED I WOULD CONTACT THE CUSTOMER WITH FURTHER INSTRUCTION FROM 0042010 01 19CRPC325 THE DEALERSHIP OR DSM. 0052010 01 21CRPC325 DEALER UNABLE TO DUPLICATE CUSTOMERS CONCERN, VEHICLE HAS AFTERMARKET FLOOR MAT. DEALER TO ADVISE CUST. TO REMOVE FLOOR MAT AND DRIVE. IF REOCCURS, CUST. TO SHOW CONCERN TO DEALER. 0062010 01 25CRPC325 NPF AT TIME OF CHECK . FOUND TO HAVE AFTERMARKET FLOORMATS, ADVISED CUSTOMER TO REMOVE FLOORMATS TO CORECT CONCERN. IF PROBLEM STILL PERSITS TO BRING VEHICLE BACK IF FOR REPAIR. NPF AT TIME OF SERVICE. VEHICLE FOUND TO HAVE AFTERMARKET FLOORMATS, ADVISE CUSTOMER TO REMOVE AFTERMARKET FLOORMATS TO CORRECT CONCERN. IF PROBLEM IS STILL PRESENT TO RETURN BACK TO THE DEALERSHIP FOR FURTHER INSPECTION.

CQIS Recommendations

Tire Information			
Tire Manufacturer	Unknown	Tire Size	Unknown
Tire Brand Series		Wheel	
DOT Left Front		DOT Right Front	
DOT Left Rear		DOT Right Rear	
DOT Left Inner		DOT Right Inner	
DOT Spare			

Vehicle Information			
VIN	4F2YZ02Z96K	Engine Serial Number	051205072402
Model Year	2006	Engine Description	2.3L DOHC EGI I4 16V NA GAS
Transmission	4 SPD AUTO TRANS MAZDA CD4E	Vehicle Description	TRIBUTE
Body Cab Style	CA WE 5 DOOR LIGHT TRUCK	Drive Line	2 WHL L/H FRONT DRIVE
Production Date	13-Jan-2006	Retail Sale Indicator Code	
Plant Description	KANSAS CITY PLANT BUILD	Required Vehicle	
Build Region		Warranty Start Date	23-Jun-2006
Build Country Code		Transmission Serial Number	
Mileage	64000	Vehicle Axle Ratio	
Vehicle Restraint Code			

Disclaimer:

This data is for use as one of several potential "awareness" indicators for the Ford Motor Co. Enhanced Concern Identification System. It is unverified, draft, summary data generated from a computer "word search" of customer and technician symptom comments. Supplier data, technician and customer comments are unverified and actual root cause of any potential issue is not established by this summary.

[Contact CDR HELP](#)
 Copyright 2001 Ford Motor Co All Rights Reserved

PE12-019

Mazda

9-6-2012

REQUEST NUMBER THREE
DOCUMENTS (SUBJECT)

Consumer Reports

Mazda CAC

ECI

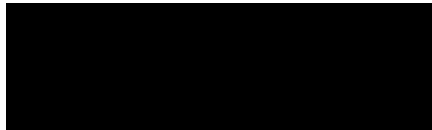



Concern Driven Reporting

Report Detail

Note: Field which are grayed (ghosted) are currently being mapped to the data warehouse. They are not presently being populated.

ECI Record		Source Code	MAZDA CAC
------------	--	-------------	-----------

Commodity Assignment			
Commodity	powertrain-engine	Symptom	no keyword found
Commodity	powertrain-engine-accel pedal/linkage/controls	Symptom	pedal concerns-accelerator pedal
Commodity	powertrain-engine-accel pedal/linkage/controls	Symptom	sticks/binds/grabs
Significant Event		Verified	N

Tread Information	
Reported in Tread Quarter	Q1 2010

Report Details			
Source Claim Key		Warranty Component Classification (WCC)	
Corporate Product Systems Classification (CPSC)		Time in Service	34
Customer Condition Code		V Function Group (VFG)	
Source System Program Type		Repair/Report/Paid Date	23-Mar-2010
Version Series Code	AAAGH	Load Date	27-Mar-2010
Causal Part Prefix-Base-Suffix	-	Dealer Code	UNKNOW
Causal Part Name	unknown	Dealer Name	
Non Causal Part Prefix-Base-Suffix		Dealer City	
Non Causal Part Numbers		Dealer State/Province	
Fault Code		Dealer Country	USA
Diagonstic Trouble Code		Dealer Phone Number	
Labor Operation Code		Attachment	
Communication Type		VOQ Component Description Code	
Maintenance Date	27-Mar-2010		

Customer Comment	CUSTOMER WANTED TO KNOW IF SHE WAS STILL WITH IN THE BASICE WARRANTY OR NOT. STATES SHE HAS BEEN HAVING AN ON GOING ISSUE WITH HER GAS PEDAL STICKING ON HER AND WANTED TO KNOW IF THIS WOULD BE COVERED UNDER ANY OTHER WARRANTY
Technician Comment	ADVISED CUSTOMER THAT VEHICLE WAS OUT OF WARRANTY BY MILLEAGE AND WOULD SUGGEST THE VEHICLE BE TAKEN INTO DEALER FOR DIAGNOSES AND THEY WOULD BE ABLE TO DETERMINE IF VEHICLE WOULD FALL UNDER ANY WARRANTY. 0012010 03 23CRPP926 REQ DESC WARRANTY COVERAGE ADVISED CUSTOMER THAT VEHICLE WAS OUT OF WARRANTY BY MILLEAGE AND WOULD SUGGEST THE VEHICLE BE TAKEN INTO DEALER FOR DIAGNOSES AND THEY WOULD BE ABLE TO DETERMINE IF VEHICLE WOULD FALL UNDER ANY WARRANTY.
CQIS Recommendations	

Tire Information			
Tire Manufacturer	Unknown	Tire Size	Unknown
Tire Brand Series		Wheel	
DOT Left Front		DOT Right Front	
DOT Left Rear		DOT Right Rear	
DOT Left Inner		DOT Right Inner	
DOT Spare			

Vehicle Information			
VIN	4F2CZ92Z88K	Engine Serial Number	160307190435
Model Year	2008	Engine Description	2.3L 4V DOHC EFI NA I4 GAS
Transmission	4 SPD AUTO TRANS NAAO CD4E	Vehicle Description	TRIBUTE
Body Cab Style	CA WE 5 DOOR LIGHT TRUCK	Drive Line	ALL 4 WHEEL LEFT HAND DRIVE
Production Date	28-Mar-2007	Retail Sale Indicator Code	
Plant Description	KANSAS CITY PLANT BUILD	Reaquired Vehicle	
Build Region		Warranty Start Date	20-Jun-2007
Build Country Code		Transmission Serial Number	
Mileage	37000	Vehicle Axle Ratio	
Vehicle Restraint Code			

Disclaimer:

This data is for use as one of several potential "awareness" indicators for the Ford Motor Co. Enhanced Concern Identification System. It is unverified, draft, summary data generated from a computer "word search" of customer and technician symptom comments. Supplier data, technician and customer comments are unverified and actual root cause of any potential issue is not established by this summary.

[Contact ODRHELP](#)

Copyright 2001 Ford Motor Co All Rights Reserved

PE12-019

Mazda

9-6-2012

REQUEST NUMBER THREE
DOCUMENTS (SUBJECT)

Consumer Reports

Mazda CAC

ECI

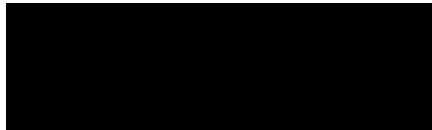



Concern Driven Reporting

Report Detail

Note: Field which are grayed (ghosted) are currently being mapped to the data warehouse. They are not presently being populated.

ECI Record		Source Code	MAZDA CAC
------------	--	-------------	-----------

Commodity Assignment

Commodity	Symptom	Administrative Cost
powertrain-engine	administrative cost	
powertrain-engine	damage	
powertrain-engine	field service action	
powertrain-engine	function-malfunction/inoperative	
powertrain-engine	mod-pre delivery	
powertrain-engine	no keyword found	
powertrain-engine	repair-prior repair mentioned	
powertrain-engine	start-will not start	
powertrain-engine-accel pedal/linkage/controls	function-malfunction/inoperative	
powertrain-engine-air induction-throttle body-	function-malfunction/inoperative	
Significant Event	Verified	N

Tread Information

Reported in Tread Quarter	Q2 2010
---------------------------	---------

Report Details

Source Claim Key	Warranty Component Classification (WCC)
Corporate Product Systems Classification (CPSC)	Time in Service 44
Customer Condition Code	V Function Group (VFG)
Source System Program Type	Repair/Report/Paid Date 30-Apr-2010
Version Series Code	Load Date 02-May-2010
Causal Part Prefix- Base - Suffix	Dealer Code 34554
Causal Part Name unknown	Dealer Name NORTH POINT MAZDA
Non Causal Part Prefix-Base-Suffix	Dealer City SHERWOOD
Non Causal Part Numbers	Dealer State/Province AR
Fault Code	Dealer Country USA
Diagonstic Trouble Code	Dealer Phone Number 5019455353
Labor Operation Code	Attachment
Communication Type	VOQ Component Description Code
Maintenance Date 27-Dec-2010	

Customer Comment	LOG NO 2029 NO START, HIGH IDLE ON 10/23/09 RCVD ATTY LTR FROM ANIBLE & EDWARDS. STS REPRESENTS CUST PURSUANT TO THE AR NEW MOTOR VEH QUALITY ASSURANCE ACT. CUST CONTACTED CUSTOMER MEDIATION & BBB BACK IN JUNE 2008 SEEKING REPURCHASE. STS CUST IS STILL EXPERIENCING SAME CONCERNS WITH TRANSMISSION & ENGINE AS BEFORE. CUSTOMER MEDIATION HANDLING CHARLIE KIM
------------------	---

Technician Comment	<p>CORPORATE REPURCHASE DUE TO MULTIPLE REPAIRS. REPLACED ALTERNATOR, TRANSMISSION, THROTTLE BODY. RCVD CONFIRMATION FROM VANESSA YU IN FINANCE THAT WIRED FUNDS WERE RCVD FROM RIVERSIDE AUTO AUCTION ON 12/21/10 FROM SALE OF VEHICLE 0012009 10 23CRPC408 REQ DESC ATTY LEMON LAW DEMAND 0022009 10 28CRPC408 SENT EMAIL TO ATTORNEY. ADVISED OF ORIGINAL IN SERVICE DATE. ADVISED WE HAVE COPY OF SALES CONTRACT FROM ORIGINAL OWNER. ADVISED MAZDA WILL OFFER \$2500, INCLUSIVE OF ATTORNEY FEES. 0032009 10 30CRPC408 RECEIVED EMAIL FROM ATTORNEY. ATTORNEY INQUIRING IF MAZDA WILL CONSIDER REPURCHASING THE VEHICLE. CALLED AND SPOKE WITH ATTORNEY. ADVISED MAZDA HAS NOT PRECLUDED THE POSSIBILITY OF REPURCHASE AS AN OPTION IF NECESSARY. ATTORNEY STATES WILL REVIEW OFFER WITH CLIENT AND CALL ME BACK. 0042009 11 20CRPC408 RECEIVED EMAIL FROM ATTORNEY DEAR MR. KIM,I UNDERSTAND THAT MAZDA USA WILL INDEMNIFY NORTH POINT MAZDA WITH RESPECT TO ITS LIABILITY IN THIS MATTER. I HAVE CONSULTED WITH MY CLIENT REGARDING YOUR REQUEST FOR A SETTLEMENT COUNTER OFFER. MY CLIENT STANDS FIRM ON HER ORIGINAL DEMAND. THE AMOUNT OF MY CLIENT'S DEMAND IS \$28,151.18 AND INCLUDES MAZDA USA REPURCHASING THE VEHICLE IN QUESTION. THIS AMOUNT WAS COMPUTED BY APPLYING THE DAMAGES PROVISIONS OF THE ARKANSAS NEW MOTOR VEHICLE QUALITY ASSURANCE ACT. THIS ACT EXPLICITLY SETS FO 0052009 11 20CRPC408 RTH THE MANNER IN WHICH DAMAGES SHOULD BE COMPUTED AND PROVIDES FOR AN AWARD OF THE CONSUMER'S ATTORNEY'S FEES. I UNDERSTAND THAT MAZDA USA HAS TAKEN THE POSITION THAT THE VEHICLE IN QUESTION WAS PLACED IN SERVICE PRIOR TO MY CLIENT'S PURCHASE OF SAME AND THAT MY CLIENT IS TIME BARRED FROM BRINGING HER CLAIM. HOWEVER, THIS POSITION IGNORES THE FACTS OF THIS CASE. NORTH POINT MAZDA SOLD THIS VEHICLE TO MY CLIENT AS A NEW VEHICLE. THIS FACT IS DOCUMENTED IN THE SALES PAPERWORK AND IN A LETTER RECEIVED FROM THE GENERAL MANAGER OF NORT 0062009 11 20CRPC408 H POINT MAZDA. THE CLOCK DID NOT BEGIN TICKING WITH RESPECT TO MY CLIENT'S CLAIM UNTIL THE DATE SHE PURCHASED THE VEHICLE. GIVEN THE FACTS OF THIS CASE, THE PROVISIONS OF THE ARKANSAS NEW MOTOR VEHICLE QUALITY ASSURANCE ACT SHOULD APPLY IN THIS CLAIM AND SAID CLAIM HAS BEEN MADE TIMELY REGARDLESS WHETHER THE VEHICLE WAS USED PRIOR TO MY CLIENT'S PURCHASE. ADDITIONALLY, SHOULD A JURY FIND THAT YOUR DEALERSHIP COMMITTED FRAUD IN THE SALE OF THIS VEHICLE TO MY CLIENT, THERE LIES THE POSSIBILITY OF PUNITIVE DAMAGES BEING AWARDED AGAI 0072009 11 20CRPC408 NST NORTH POINT MAZDA.I AM HOPEFUL THAT WE WILL BE ABLE TO RESOLVE THIS MATTER WITHOUT THE NEED OF LITIGATION. I AWAIT YOUR REPLY. SENT EMAIL TO ATTORNEY. ADVISED MAZDA IS WILLING TO SETTLE FOR \$3500.00, INCLUSIVE OF ATTORNEY FEES. ADVISED WE WOULD TAKE FULL USAGE AS PERMITTED BY THE STATE EVEN IF WE HAD TO REPURCHASE THE VEHICLE. ADVISED THEIR CLIENT'S REQUEST FOR \$28,151.18 SETTLEMENT OFFER IS REASONABLE. 0082009 11 25CRPC408 SENT EMAIL TO ATTORNEY. ADVISED MAZDA IS WILLING TO SETTLE FOR \$3500.00, INCLUSIVE OF ATTORNEY FEES. ADVISED WE WOULD TAKE FULL USAGE AS PERMITTED BY THE STATE EVEN IF WE HAD TO REPURCHASE THE VEHICLE. RECVD EMAIL FROM ATTORNEY. STATES THE BREAKDOWN FORMULA FOR THE SETTLEMENT OF \$28,000. SENT EMAIL TO ATTORNEY. ADVISED MAZDA IS WILLING TO OFFER \$6,000.00, INCLUSIVE OF ATTORNEY FEES. 0092009 12 01CRPC408 RECEIVED EMAIL FROM ATTORNEY DEAR MR. KIM,MY CLIENT IS WILLING TO FULLY RESOLVE THIS MATTER BY PAYMENT OF \$26,151.18.I AWAIT YOUR RESPONSE. SENT EMAIL TO ATTORNEY. ADVISED THIS CASE WILL BE FORWARDED TO SENIOR SPECIALIST FOR REVIEW. ADVISED WILL NEED CURRENT REGISTRATION AND LOAN INFO SHOWING PAYOFF AND PAYMENT HISTORY. 0102009 12 08CRPC408 FILE FORWARDED TO SENIOR SPECIALIST, MARIE, FOR REVIEW. 0112010 04 28CRPP939 _____ FROM MARIE MORTENSEN SENT WEDNESDAY, APRIL 28, 2010 3 06 PMTO 'BRUCE ANIBLE'SUBJECT _____ MAZDA REPURCHASE OFFERATTACHED PLEASE FIND OUR OFFER TO REPURCHASE YOUR CLIENTS 2006 TRIBUTE. PLEASE CONTACT ME WITH ANY QUESTIONS. MARIE MORTENSEN SENIOR SPECIALIST, CUSTOMER MEDIATIONMAZDA NORTH AMERICAN OPERATIONS949 727 6380 PHONE949 727 6592 FAXMMORTENS@MAZDAUSA.COM 0122010 04 30CRPP939 RECEIVED SIGNED ACCEPTANCE OF OFFER. SUBMITTED CHECK REQUEST. 0132010 05 24CRPP939 SENT EMAIL TO ATTORNEY REQUESTING A COPY OF THE CURRENT REGISTRATION AS THE REGISTRATION THAT I HAVE EXPIRED IN FEB. 2010. 0142010 05 25CRPP939 RECEIVED CURRENT REGISTRATION, SENT CHECKS AND CONTACT PACKAGE TO ISG. 0152010 06 02CRPP939 ATTORNEY ADVISED HE HAD BEEN CONTACTED BY ISG TODAY. 0162010 06 07CRPC399 VEHICLE TRANSACTION COMPLETED NOTIFICATION THE ABOVE REFERENCED VEHICLE WAS TURNED INTO NORTH POINT MAZDA ON 06/04/2010. THE VEHICLE WAS REPURCHASED FOR 1. MULTIPLE REPAIRS NO START, HIGH IDLE.. 0172010 08 26CRPC399 PER RACHEL AT ISG VEH WAS MOVED TO REPAIRING DEALER FREEMAN MAZDA ON 06/26 0182010 10 29CRPC399 RANDY HATZL SENT FINAL RO'S INDICATING VEH HAS BEEN REPAIRED SENT RACHEL @ ISG AN E MAIL REQUESTING TO SEND VEH TO AUCTION 0192010 12 22CRPC399 RCVD CONFIRMATION FROM VANESSA YU IN FINANCE THAT WIRED FUNDS WERE RCVD FROM RIVERSIDE AUTO AUCTION ON 12/21/10 FROM SALE OF VEHICLE</p>
CQIS Recommendations	

Tire Information			
Tire Manufacturer	Unknown	Tire Size	Unknown
Tire Brand Series		Wheel	
DOT Left Front		DOT Right Front	
DOT Left Rear		DOT Right Rear	
DOT Left Inner		DOT Right Inner	
DOT Spare			

Vehicle Information			
VIN	4F2YZ02Z56K _____	Engine Serial Number	070905124726
Model Year	2006	Engine Description	2.3L DOHC EGI I4 16V NA GAS
Transmission	4 SPD AUTO TRANS MAZDA CD4E	Vehicle Description	TRIBUTE
Body Cab Style	Unknown	Drive Line	2 WHL L/H FRONT DRIVE
Production Date	20-Dec-2005	Retail Sale Indicator Code	
Plant Description	KANSAS CITY PLANT BUILD	Required Vehicle	
Build Region		Warranty Start Date	22-Sep-2006
Build Country Code		Transmission Serial Number	
Mileage	0	Vehicle Axle Ratio	
Vehicle Restraint Code			

Disclaimer:

This data is for use as one of several potential "awareness" indicators for the Ford Motor Co. Enhanced Concern Identification System. It is unverified, draft, summary data generated from a computer "word search" of customer and technician symptom comments. Supplier data, technician and customer comments are unverified and actual root cause of any potential issue is not established by this summary.

[Contact ODRHELP](#)

Copyright 2001 Ford Motor Co All Rights Reserved

PE12-019

Mazda

9-6-2012

REQUEST NUMBER THREE
DOCUMENTS (SUBJECT)

Consumer Reports

Mazda CAC

ECI

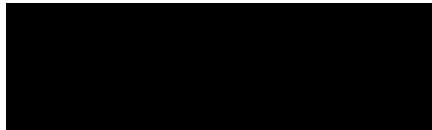

DOT Left Front		DOT Right Front	
DOT Left Rear		DOT Right Rear	
DOT Left Inner		DOT Right Inner	
DOT Spare			

Vehicle Information

VIN	4F2CZ02Z98K [REDACTED]	Engine Serial Number	181207215733
Model Year	2008	Engine Description	2.3L 4V DOHC EFI NA I4 GAS
Transmission	4 SPD AUTO TRANS NAAO CD4E	Vehicle Description	TRIBUTE
Body Cab Style	Unknown	Drive Line	2 WHL L/H FRONT DRIVE
Production Date	04-Jan-2008	Retail Sale Indicator Code	
Plant Description	KANSAS CITY PLANT BUILD	Required Vehicle	
Build Region		Warranty Start Date	12-Mar-2008
Build Country Code		Transmission Serial Number	I20773480132
Mileage	41000	Vehicle Axle Ratio	
Vehicle Restraint Code			

Disclaimer:

This data is for use as one of several potential "awareness" indicators for the Ford Motor Co. Enhanced Concern Identification System. It is unverified, draft, summary data generated from a computer "word search" of customer and technician symptom comments. Supplier data, technician and customer comments are unverified and actual root cause of any potential issue is not established by this summary.

[Contact CDR HELP](#)

Copyright 2001 Ford Motor Co. All Rights Reserved

PE12-019

Mazda

9-6-2012

REQUEST NUMBER THREE
DOCUMENTS (SUBJECT)

Consumer Reports

Mazda CAC

ECI

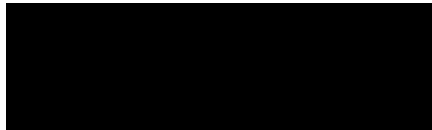



Concern Driven Reporting

Report Detail

Note: Field which are grayed (ghosted) are currently being mapped to the data warehouse. They are not presently being populated.

ECI Record		Source Code	MAZDA CAC
------------	--	-------------	-----------

Commodity Assignment

Commodity	powertrain-engine	Symptom	field service action
Commodity	powertrain-engine-accel pedal/linkage/controls	Symptom	field service action
Commodity	powertrain-engine-accel pedal/linkage/controls	Symptom	mod-intermittent/random
Commodity	powertrain-engine-accel pedal/linkage/controls	Symptom	pedal concerns-accelerator pedal
Commodity	powertrain-engine-accel pedal/linkage/controls	Symptom	sticks/binds/grabs
Significant Event		Verified	N

Tread Information

Reported in Tread Quarter	Q3 2010
---------------------------	---------

Report Details

Source Claim Key		Warranty Component Classification (WCC)	
Corporate Product Systems Classification (CPS)		Time in Service	88
Customer Condition Code		V Function Group (VFG)	
Source System Program Type		Repair/Report/Paid Date	18-Aug-2010
Version Series Code	AAAA5	Load Date	22-Aug-2010
Causal Part Prefix-Base-Suffix	-	Dealer Code	UNKNOW
Causal Part Name	unknown	Dealer Name	
Non Causal Part Prefix-Base-Suffix		Dealer City	
Non Causal Part Numbers		Dealer State/Province	
Fault Code		Dealer Country	USA
Diagnostic Trouble Code		Dealer Phone Number	
Labor Operation Code		Attachment	
Communication Type		VOQ Component Description Code	
Maintenance Date	22-Aug-2010		

Customer Comment	CUSTOMER STATES THAT THE THROTTLE SOMETIMES STICKS. INQUIRING ABOUT RECALLS.
Technician Comment	ADVISED THAT THERE WAS A RECALL FOR THE THROTTLE CABLE BUT IT WAS COMPLETED IN 2005. 0012010 08 18rcpc802 REQ DESC THROTTLE STICKING ADVISED THAT THERE WAS A RECALL FOR THE THROTTLE CABLE BUT IT WAS COMPLETED IN 2005.
CQIS Recommendations	

Tire Information

Tire Manufacturer	Unknown	Tire Size	Unknown
Tire Brand Series		Wheel	
DOT Left Front		DOT Right Front	
DOT Left Rear		DOT Right Rear	
DOT Left Inner		DOT Right Inner	
DOT Spare			

Vehicle Information

VIN	4F2YZ04193K	Engine Serial Number	
Model Year	2003	Engine Description	3.0L DOHC EGI V6 NA*G DSP2967
Transmission	4 SPD AUTO TRANS MAZDA CD4E	Vehicle Description	TRIBUTE
Body Cab Style	CA WE 5 DOOR LIGHT TRUCK	Drive Line	2 WHL L/H FRONT DRIVE
Production Date	27-Mar-2003	Retail Sale Indicator Code	
Plant Description	KANSAS CITY PLANT BUILD	Required Vehicle	
Build Region		Warranty Start Date	11-Jun-2003
Build Country Code		Transmission Serial Number	
Mileage	108000	Vehicle Axle Ratio	
Vehicle Restraint Code			

Disclaimer:

This data is for use as one of several potential "awareness" indicators for the Ford Motor Co. Enhanced Concern Identification System. It is unverified, draft, summary data generated from a computer "word search" of customer and technician symptom comments. Supplier data, technician and customer comments are unverified and actual root cause of any potential issue is not established by this summary.

[Contact ODRHELP](#)

Copyright 2001 Ford Motor Co All Rights Reserved

PE12-019

Mazda

9-6-2012

REQUEST NUMBER THREE
DOCUMENTS (SUBJECT)

Consumer Reports

Mazda CAC

ECI

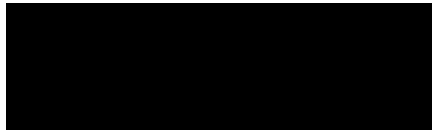



Concern Driven Reporting

Report Detail

Note: Field which are grayed (ghosted) are currently being mapped to the data warehouse. They are not presently being populated.

ECI Record		Source Code	MAZDA CAC
------------	--	-------------	-----------

Commodity Assignment

Commodity	powertrain-engine	Symptom	field service action
Commodity	powertrain-engine	Symptom	function-false activation/cycle/deploy
Commodity	powertrain-engine	Symptom	function-malfunction/inoperative
Commodity	powertrain-engine	Symptom	no keyword found
Commodity	powertrain-engine	Symptom	repair-prior repair mentioned
Commodity	powertrain-engine-accel pedal/linkage/controls	Symptom	high effort
Commodity	powertrain-engine-accel pedal/linkage/controls	Symptom	sticks/binds/grabs
Significant Event		Verified	N

Tread Information

Reported in Tread Quarter Q3 2010

Report Details

Source Claim Key		Warranty Component Classification (WCC)	
Corporate Product Systems Classification (CPSC)		Time in Service	94
Customer Condition Code		V Function Group (VFG)	
Source System Program Type		Repair/Report/Paid Date	22-Sep-2010
Version Series Code	AAAQK	Load Date	26-Sep-2010
Causal Part Prefix-Base-Suffix	-	Dealer Code	UNKNOW
Causal Part Name	unknown	Dealer Name	
Non Causal Part Prefix-Base-Suffix		Dealer City	
Non Causal Part Numbers		Dealer State/Province	
Fault Code		Dealer Country	USA
Diagnostic Trouble Code		Dealer Phone Number	
Labor Operation Code		Attachment	
Communication Type		VOQ Component Description Code	
Maintenance Date	26-Sep-2010		

Customer Comment CUSTOMER STATES SHE IS HAVING TROUBLE WITH THE RPMS ON HER VEHICLE GOING UP ON THEIR OWN. CUSTOMER STATES THAT SHE HAD A THROTTLE CABLE REPLACED PREVIOUSLY UNDER THE RECALL. CUSTOMER WOULD LIKE TO KNOW IF SHE CAN HAVE THIS RECALL PERFORMED AGAIN.

Technician Comment REVIEWED ISSUE WITH CUSTOMER 130K MILESNOT BEEN INSPECTEDNO ASSISTANCE... 0012010 09 22CRPP279 REQ DESC THROTTLE STUCK AGENT ADVISED CUSTOMER THAT THE VEHICLE WOULD NEED TO GO TO A DEALERSHIP TO BE DIAGNOSED BEFORE WE COULD MAKE ANY DECISION BUT THAT THE VEHICLE IS WELL OUTSIDE OF THE WARRANTY. AGENT ADVISED THAT ASSISTANCE WOULD BE VERY SLIM AND PROBABLY NO ASSISTANCE WOULD BE OFFERED. CUSTOMER STATES WOULD LIKE TO ESCALATE TO SUPERVISOR AS SHE FEELS THIS IS A SAFETY CONCERNS. AGENT CHECKED WITH SUPERVISOR TIM AND HE IS AVAILABLE. AGENT TRANSFERRED CALL TO SUPERVISOR TIM WITH PERMISSION. 0022010 09 22CRPC606 REVIEWED ISSUE WITH CUSTOMER 130K MILESNOT BEEN INSPECTEDNO ASSISTANCE... 0032010 09 22CRPP104 CUSTOMER CALLED AND WANTED SUPERVISORS SUPERVISOR. AGENT ADVISED SHE SPOKE WITH THE HIGHEST LEVEL OF ESCALATION HERE. CUSTOMER DISAGREED AND DISCONNECTED CALL

CQIS Recommendations

Tire Information

Tire Manufacturer	Unknown	Tire Size	Unknown
Tire Brand Series		Wheel	
DOT Left Front		DOT Right Front	
DOT Left Rear		DOT Right Rear	
DOT Left Inner		DOT Right Inner	
DOT Spare			

Vehicle Information

VIN	4F2CZ96173K	Engine Serial Number	
Model Year	2003	Engine Description	3.0L DOHC EGI V6 NA*G DSP2967
Transmission	4 SPD AUTO TRANS MAZDA CD4E	Vehicle Description	TRIBUTE
Body Cab Style	CA WE 3 DOOR LIGHT TRUCK	Drive Line	4 WHL L/H PART TIME DRIVE
Production Date	02-Dec-2002	Retail Sale Indicator Code	
Plant Description	KANSAS CITY PLANT BUILD	Reaquired Vehicle	
Build Region		Warranty Start Date	17-Jan-2003
Build Country Code		Transmission Serial Number	
Mileage	130000	Vehicle Axle Ratio	
Vehicle Restraint Code			

Disclaimer:

This data is for use as one of several potential "awareness" indicators for the Ford Motor Co. Enhanced Concern Identification System. It is unverified, draft, summary data generated from a computer "word search" of customer and technician symptom comments. Supplier data, technician and customer comments are unverified and actual root cause of any potential issue is not established by this summary.

[Contact ODRHELP](#)

Copyright 2001 Ford Motor Co All Rights Reserved

PE12-019

Mazda

9-6-2012

REQUEST NUMBER THREE
DOCUMENTS (SUBJECT)

Consumer Reports

Mazda CAC

ECI

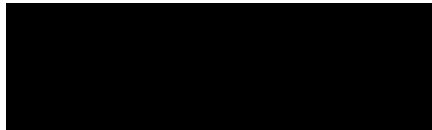



Concern Driven Reporting

Report Detail

Note: Field which are grayed (ghosted) are currently being mapped to the data warehouse. They are not presently being populated.

ECI Record		Source Code	MAZDA CAC
------------	--	-------------	-----------

Commodity Assignment

Commodity	powertrain-engine	Symptom	high effort
Commodity	powertrain-engine-accel pedal/linkage/controls	Symptom	function-malfunction/inoperative
Commodity	powertrain-engine-accel pedal/linkage/controls	Symptom	high effort
Commodity	powertrain-engine-accel pedal/linkage/controls	Symptom	pedal concerns-accelerator pedal
Commodity	powertrain-engine-accel pedal/linkage/controls	Symptom	sticks/binds/grabs
Significant Event		Verified	N

Tread Information

Reported in Tread Quarter	Q4 2010
---------------------------	---------

Report Details

Source Claim Key		Warranty Component Classification (WCC)	
Corporate Product Systems Classification (CPS)		Time in Service	60
Customer Condition Code		V Function Group (VFG)	
Source System Program Type		Repair/Report/Paid Date	05-Oct-2010
Version Series Code	AAAGH	Load Date	10-Oct-2010
Causal Part Prefix-Base-Suffix	-	Dealer Code	23816
Causal Part Name	unknown	Dealer Name	MAZDA OF DOTHAN
Non Causal Part Prefix-Base-Suffix		Dealer City	DOTHAN
Non Causal Part Numbers		Dealer State/Province	AL
Fault Code		Dealer Country	USA
Diagnostic Trouble Code		Dealer Phone Number	
Labor Operation Code		Attachment	
Communication Type		VOQ Component Description Code	
Maintenance Date	10-Oct-2010		

Customer Comment	CUSTOMER STATES THAT THEY HAD A SIMILAR PROBLEM WITH THE GAS PEDAL STICKING OVER A YEAR AGO AND MAZDA OFFERED ASSISTANCE. CONCERN IS RETURNING AND WAS INQUIRING ABOUT GOODWILL. LAST TOOK THE DEALER 5 6 MONTHS AGO.
Technician Comment	AGENT ADVISED THAT VEHICLE WAS BEYOND THE LIMITS OF PART WARRANTY AND GOODWILL GUIDELINES. NO ASSISTANCE COULD BE OFFERED IN THIS REPAIR. ADVISED THAT CONCERNS WERE DOCUMENTED AND CUSTOMER WOULD RECEIVE NOTIFICATION IF REIMBURSEMENT EVER WAS POSSIBLE. 0012010 10 05crpc802 REQ DESC GAS PEDAL STICKING AGENT ADVISED THAT VEHICLE WAS BEYOND THE LIMITS OF PART WARRANTY AND GOODWILL GUIDELINES. NO ASSISTANCE COULD BE OFFERED IN THIS REPAIR. ADVISED THAT CONCERNS WERE DOCUMENTED AND CUSTOMER WOULD RECEIVE NOTIFICATION IF REIMBURSEMENT EVER WAS POSSIBLE.
CQIS Recommendations	

Tire Information

Tire Manufacturer	Unknown	Tire Size	Unknown
Tire Brand Series		Wheel	
DOT Left Front		DOT Right Front	
DOT Left Rear		DOT Right Rear	
DOT Left Inner		DOT Right Inner	
DOT Spare			

Vehicle Information

VIN	4F2YZ02Z46K	Engine Serial Number	
Model Year	2006	Engine Description	2.3L DOHC EGI I4 16V NA GAS
Transmission	5 SPD MAN TRANS MAZDA M5	Vehicle Description	TRIBUTE
Body Cab Style	CA WE 3 DOOR LIGHT TRUCK	Drive Line	2 WHL L/H FRONT DRIVE
Production Date	03-Jun-2005	Retail Sale Indicator Code	
Plant Description	KANSAS CITY PLANT BUILD	Required Vehicle	
Build Region		Warranty Start Date	28-Nov-2005
Build Country Code		Transmission Serial Number	
Mileage	110000	Vehicle Axle Ratio	
Vehicle Restraint Code			

Disclaimer:

This data is for use as one of several potential "awareness" indicators for the Ford Motor Co. Enhanced Concern Identification System. It is unverified, draft, summary data generated from a computer "word search" of customer and technician symptom comments. Supplier data, technician and customer comments are unverified and actual root cause of any potential issue is not established by this summary.

[Contact ODRHELP](#)

Copyright 2001 Ford Motor Co All Rights Reserved

PE12-019

Mazda

9-6-2012

REQUEST NUMBER THREE
DOCUMENTS (SUBJECT)

Consumer Reports

Mazda CAC

ECI

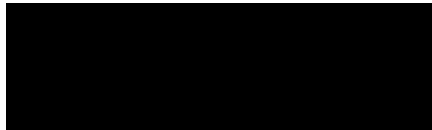



Concern Driven Reporting

Report Detail

Note: Field which are grayed (ghosted) are currently being mapped to the data warehouse. They are not presently being populated.

ECI Record		Source Code	MAZDA CAC
------------	--	-------------	-----------

Commodity Assignment

Commodity	powertrain-engine	Symptom	no keyword found
Commodity	powertrain-engine-accel pedal/linkage/controls	Symptom	mvh-noisy operation
Commodity	powertrain-engine-accel pedal/linkage/controls	Symptom	sticks/binds/grabs
Significant Event		Verified	N

Tread Information

Reported in Tread Quarter	Q4 2010
---------------------------	---------

Report Details

Source Claim Key		Warranty Component Classification (WCC)	
Corporate Product Systems Classification (CPSC)		Time in Service	73
Customer Condition Code		V Function Group (VFG)	
Source System Program Type		Repair/Report/Paid Date	08-Oct-2010
Version Series Code	AAAGH	Load Date	10-Oct-2010
Causal Part Prefix-Base-Suffix	-	Dealer Code	UNKNOW
Causal Part Name	unknown	Dealer Name	
Non Causal Part Prefix-Base-Suffix		Dealer City	
Non Causal Part Numbers		Dealer State/Province	
Fault Code		Dealer Country	USA
Diagonstic Trouble Code		Dealer Phone Number	
Labor Operation Code		Attachment	
Communication Type		VOQ Component Description Code	
Maintenance Date	10-Oct-2010		

Customer Comment	CUSTOMER CALLED REGARDING RECALL HE HEARD ABOUT FOR ACCELERATION PEDAL STICKING. ADVISED HE HAS EXPERIANCED THIS CONDITION IN VEHICLE. VEHICLE PURCHASE NEW IN 2004.
Technician Comment	ADVISED CUSTOMER THERE ARE CURRENTLY NO OPEN RECALLS FOR VEHICLE. CUSTOMER THANKED. 0012010 10 08crpc034 REQ DESC RECALL INQUIRY ADVISED CUSTOMER THERE ARE CURRENTLY NO OPEN RECALLS FOR VEHICLE. CUSTOMER THANKED.
CQIS Recommendations	

Tire Information

Tire Manufacturer	Unknown	Tire Size	Unknown
Tire Brand Series		Wheel	
DOT Left Front		DOT Right Front	
DOT Left Rear		DOT Right Rear	
DOT Left Inner		DOT Right Inner	
DOT Spare			

Vehicle Information

VIN	4F2YZ92ZX5K	Engine Serial Number	130104052118
Model Year	2005	Engine Description	2.3L DOHC EGI I4 16V NA GAS
Transmission	4 SPD AUTO TRANS MAZDA CD4E	Vehicle Description	TRIBUTE
Body Cab Style	CA WE 5 DOOR LIGHT TRUCK	Drive Line	4 WHL L/H PART TIME DRIVE
Production Date	05-Feb-2004	Retail Sale Indicator Code	
Plant Description	KANSAS CITY PLANT BUILD	Reaquired Vehicle	
Build Region		Warranty Start Date	25-Oct-2004
Build Country Code		Transmission Serial Number	
Mileage	108000	Vehicle Axle Ratio	
Vehicle Restraint Code			

Disclaimer:

This data is for use as one of several potential "awareness" indicators for the Ford Motor Co. Enhanced Concern Identification System. It is unverified, draft, summary data generated from a computer "word search" of customer and technician symptom comments. Supplier data, technician and customer comments are unverified and actual root cause of any potential issue is not established by this summary.

[Contact ODRHELP](#)

Copyright 2001 Ford Motor Co All Rights Reserved

PE12-019

Mazda

9-6-2012

REQUEST NUMBER THREE
DOCUMENTS (SUBJECT)

Consumer Reports

Mazda CAC

ECI

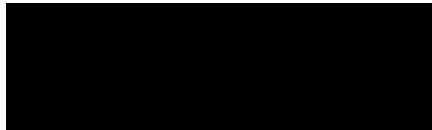



Concern Driven Reporting

Report Detail

Note: Field which are grayed (ghosted) are currently being mapped to the data warehouse. They are not presently being populated.

ECI Record		Source Code	MAZDA CAC
------------	--	-------------	-----------

Commodity Assignment			
Commodity	powertrain-engine—	Symptom	field service action
Commodity	powertrain-engine—	Symptom	function-malfunction/inoperative
Commodity	powertrain-engine-accel pedal/linkage/controls—	Symptom	function-malfunction/inoperative
Commodity	powertrain-engine-accel pedal/linkage/controls—	Symptom	no problem found
Commodity	powertrain-engine-accel pedal/linkage/controls—	Symptom	pedal concerns-accelerator pedal
Commodity	powertrain-engine-accel pedal/linkage/controls—	Symptom	sticks/binds/grabs
Commodity	powertrain-engine-air induction-throttle body-	Symptom	function-malfunction/inoperative
Commodity	powertrain-engine-air induction-throttle body-	Symptom	no problem found
Commodity	powertrain-engine-air induction-throttle body-	Symptom	sticks/binds/grabs
Significant Event		Verified	N

Tread Information	
Reported in Tread Quarter	Q4 2010

Report Details			
Source Claim Key		Warranty Component Classification (WCC)	
Corporate Product Systems Classification (CPSC)		Time in Service	110
Customer Condition Code		V Function Group (VFG)	
Source System Program Type		Repair/Report/Paid Date	02-Nov-2010
Version Series Code	AAAQK	Load Date	07-Nov-2010
Causal Part Prefix- Base - Suffix	-	Dealer Code	UNKNOW
Causal Part Name	unknown	Dealer Name	
Non Causal Part Prefix-Base-Suffix		Dealer City	
Non Causal Part Numbers		Dealer State/Province	
Fault Code		Dealer Country	USA
Diagnotic Trouble Code		Dealer Phone Number	
Labor Operation Code		Attachment	
Communication Type		VOQ Component Description Code	
Maintenance Date	07-Nov-2010		

Customer Comment	CUSTOMER STATES SHE'S BEEN EXPERIENCING PROBLEMS WHERE THE VEHICLES THROTTLE BODY IS STICKING AND THE VEHICLES RPM CONTINUES TO GET HIGHER. SHE HAS EXPERIENCED THIS SERVERAL TIMES AND WHEN SHE BROUGHT VEHICLE TO MAZDA DEALER, DEALER WAS NOT ABLE TO DUPLICATE. ALSO STATES SHE'S BEEN HAVING PROBLEMS WITH LOCKING THE LATCH TO HER VEHICLE.
Technician Comment	AGENT ADVISED CUSTOMER THAT IF SHE FEELS AT ANY TIME THAT SAFETY IS AN ISSUE AND SHE IS WORRIED ABOUT A DIAGNOSTIC FEE, TO STILL TAKE THE VEHICLE TO A MAZDA DEALER TO HAVE THEM DETERMINE WHAT IS CAUSING THE PROBLEMS. ALSO STATED THAT ALTHOUGH SHE IS OUT OF WARRANTY, SHE CAN STILL TAKE TO DEALER. CUSTOMER THANKED AGENT. 0012010 11 02crpc036 REQ DESC RECALL INQUIRY AGENT ADVISED CUSTOMER THAT IF SHE FEELS AT ANY TIME THAT SAFETY IS AN ISSUE AND SHE IS WORRIED ABOUT A DIAGNOSTIC FEE, TO STILL TAKE THE VEHICLE TO A MAZDA DEALER TO HAVE THEM DETERMINE WHAT IS CAUSING THE PROBLEMS. ALSO STATED THAT ALTHOUGH SHE IS OUT OF WARRANTY, SHE CAN STILL TAKE TO DEALER. CUSTOMER THANKED AGENT.
CQIS Recommendations	

Tire Information			
Tire Manufacturer	Unknown	Tire Size	Unknown
Tire Brand Series		Wheel	
DOT Left Front		DOT Right Front	
DOT Left Rear		DOT Right Rear	
DOT Left Inner		DOT Right Inner	
DOT Spare			

Vehicle Information			
VIN	4F2YU09162K	Engine Serial Number	018675087
Model Year	2002	Engine Description	3.0L DOHC EGI V6 NA*GAS
Transmission	4 SPD AUTO TRANS MAZDA CD4E	Vehicle Description	TRIBUTE
Body Cab Style	CA WE 5 DOOR LIGHT TRUCK	Drive Line	2 WHL L/H FRONT DRIVE
Production Date	28-Aug-2001	Retail Sale Indicator Code	
Plant Description	KANSAS CITY PLANT BUILD	Required Vehicle	
Build Region		Warranty Start Date	13-Nov-2001
Build Country Code		Transmission Serial Number	
Mileage	91000	Vehicle Axle Ratio	
Vehicle Restraint Code			

Disclaimer:

This data is for use as one of several potential "awareness" indicators for the Ford Motor Co. Enhanced Concern Identification System. It is unverified, draft, summary data generated from a computer "word search" of customer and technician symptom comments. Supplier data, technician and customer comments are unverified and actual root cause of any potential issue is not established by this summary.

[Contact ODRHELP](#)

Copyright 2001 Ford Motor Co All Rights Reserved

PE12-019

Mazda

9-6-2012

REQUEST NUMBER THREE
DOCUMENTS (SUBJECT)

Consumer Reports

Mazda CAC

ECI

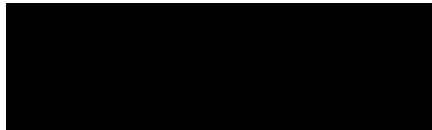



Concern Driven Reporting

Report Detail

Note: Field which are grayed (ghosted) are currently being mapped to the data warehouse. They are not presently being populated.

ECI Record		Source Code	MAZDA CAC
------------	--	-------------	-----------

Commodity Assignment

Commodity	powertrain-engine	Symptom	no keyword found
Commodity	powertrain-engine-accel pedal/linkage/controls	Symptom	field service action
Commodity	powertrain-engine-accel pedal/linkage/controls	Symptom	pedal concerns-accelerator pedal
Commodity	powertrain-engine-accel pedal/linkage/controls	Symptom	pressure-low
Significant Event		Verified	N

Tread Information

Reported in Tread Quarter	Q4 2010
---------------------------	---------

Report Details

Source Claim Key		Warranty Component Classification (WCC)	
Corporate Product Systems Classification (CPS)		Time in Service	28
Customer Condition Code		V Function Group (VFG)	
Source System Program Type		Repair/Report/Paid Date	09-Dec-2010
Version Series Code		Load Date	12-Dec-2010
Causal Part Prefix- Base - Suffix	-	Dealer Code	UNKNOW
Causal Part Name	unknown	Dealer Name	
Non Causal Part Prefix-Base-Suffix		Dealer City	
Non Causal Part Numbers		Dealer State/Province	
Fault Code		Dealer Country	USA
Diagnostic Trouble Code		Dealer Phone Number	
Labor Operation Code		Attachment	
Communication Type		VOQ Component Description Code	
Maintenance Date	12-Dec-2010		

Customer Comment CUSTOMER STATES IN THE MORNING IT IS HARD TO PRESS DOWN ON THE GAS PEDAL. HE STATES IT HAS BEEN HAPPENING MORE AND MORE OFTEN. CUSTOMER WOULD LIKE TO KNOW IF THIS WOULD BE COVERED UNDER WARRANTY OR IF THIS IS A RECALL.

Technician Comment AGENT ADVISED CUSTOMER THAT HE WOULD NEED TO TAKE THE VEHICLE TO THE DEALERSHIP FOR THEM TO DIAGNOSE AND THAT AT THIS POINT HIS VEHICLE IS OUT OF WARRANTY. AGENT ADVISED CUSTOMER THAT THERE ARE NO OPEN RECALLS ON THE VEHICLE. 0012010 12 09crpc330 REQ DESC GAS PEDAL CONCERN

CQIS Recommendations

Tire Information

Tire Manufacturer	Unknown	Tire Size	P235/70R 16T BSW A S
Tire Brand Series		Wheel	
DOT Left Front		DOT Right Front	
DOT Left Rear		DOT Right Rear	
DOT Left Inner		DOT Right Inner	
DOT Spare			

Vehicle Information

VIN	4F2CZ02ZX8K	Engine Serial Number	260308022237
Model Year	2008	Engine Description	2.3L 4V DOHC EFI NA I4 GAS
Transmission	4 SPD AUTO TRANS NAAO CD4E	Vehicle Description	TRIBUTE
Body Cab Style	Unknown	Drive Line	2 WHL L/H FRONT DRIVE
Production Date	04-Apr-2008	Retail Sale Indicator Code	
Plant Description	KANSAS CITY PLANT BUILD	Required Vehicle	
Build Region		Warranty Start Date	30-Aug-2008
Build Country Code		Transmission Serial Number	030880850019
Mileage	39000	Vehicle Axle Ratio	
Vehicle Restraint Code			

Disclaimer:

This data is for use as one of several potential "awareness" indicators for the Ford Motor Co. Enhanced Concern Identification System. It is unverified, draft, summary data generated from a computer "word search" of customer and technician symptom comments. Supplier data, technician and customer comments are unverified and actual root cause of any potential issue is not established by this summary.

[Contact ODRHELP](#)

Copyright 2001 Ford Motor Co All Rights Reserved

PE12-019

Mazda

9-6-2012

REQUEST NUMBER THREE
DOCUMENTS (SUBJECT)

Consumer Reports

Mazda CAC

ECI

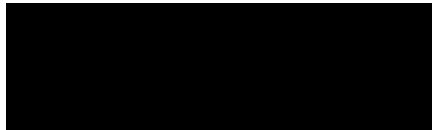



Concern Driven Reporting

Report Detail

Note: Field which are grayed (ghosted) are currently being mapped to the data warehouse. They are not presently being populated.

ECI Record		Source Code	MAZDA CAC
------------	--	-------------	-----------

Commodity Assignment			
Commodity	powertrain-engine	Symptom	mod-vehicle towed in
Commodity	powertrain-engine-accel pedal/linkage/controls	Symptom	mod-vehicle towed in
Commodity	powertrain-engine-accel pedal/linkage/controls	Symptom	pedal concerns-accelerator pedal
Commodity	powertrain-engine-accel pedal/linkage/controls	Symptom	sticks/binds/grabs
Significant Event		Verified	N

Tread Information	
Reported in Tread Quarter	Q4 2010

Report Details			
Source Claim Key		Warranty Component Classification (WCC)	
Corporate Product Systems Classification (CPSC)		Time in Service	62
Customer Condition Code		V Function Group (VFG)	
Source System Program Type		Repair/Report/Paid Date	10-Dec-2010
Version Series Code	AAAGH	Load Date	12-Dec-2010
Causal Part Prefix-Base-Suffix	-	Dealer Code	23778
Causal Part Name	unknown	Dealer Name	ED MORSE MAZDA
Non Causal Part Prefix-Base-Suffix		Dealer City	PORT RICHEY
Non Causal Part Numbers		Dealer State/Province	FL
Fault Code		Dealer Country	USA
Diagnostic Trouble Code		Dealer Phone Number	7278625411
Labor Operation Code		Attachment	
Communication Type		VOQ Component Description Code	
Maintenance Date	12-Dec-2010		

Customer Comment	CUSTOMER CALLED IN BECAUSE SHE WAS STUCK ON THE SIDE OF THE ROAD BECAUSE HER GAS PEDAL GOT STUCK TO THE FLOOR AND NEEDED ASSISTANCE.
Technician Comment	AGENT ADVISED CUSTOMER TO HAVE VEHICLE TOWED TO NEAREST MAZDA DEALERSHIP. PROVIDED FILE NUMBER [REDACTED] 10crpc035 REQ DESC GAS PEDAL ORIGINAL CALL AGENT ADVISED CUSTOMER THAT VEHICLE WAS OUTSIDE THE LIMITATIONS OF WARRANTY. CUSTOMER STATED SHE HAD AAA. AGENT ADVISED THAT SHE HAVE VEHICLE TOWED TO NEAREST MAZDA DEALERSHIP FOR REPAIR. AGENT ADVISED CUSTOMER TO HAVE VEHICLE TOWED TO NEAREST MAZDA DEALERSHIP. PROVIDED FILE NUMBER.
CQIS Recommendations	

Tire Information			
Tire Manufacturer	Unknown	Tire Size	Unknown
Tire Brand Series		Wheel	
DOT Left Front		DOT Right Front	
DOT Left Rear		DOT Right Rear	
DOT Left Inner		DOT Right Inner	
DOT Spare			

Vehicle Information			
VIN	4F2YZ02ZX6K [REDACTED]	Engine Serial Number	050905131849
Model Year	2006	Engine Description	2.3L DOHC EGI I4 16V NA GAS
Transmission	4 SPD AUTO TRANS MAZDA CD4E	Vehicle Description	TRIBUTE
Body Cab Style	CA WE 5 DOOR LIGHT TRUCK	Drive Line	2 WHL L/H FRONT DRIVE
Production Date	24-Sep-2005	Retail Sale Indicator Code	
Plant Description	KANSAS CITY PLANT BUILD	Required Vehicle	
Build Region		Warranty Start Date	19-Nov-2005
Build Country Code		Transmission Serial Number	
Mileage	82571	Vehicle Axle Ratio	
Vehicle Restraint Code			

Disclaimer:

This data is for use as one of several potential "awareness" indicators for the Ford Motor Co. Enhanced Concern Identification System. It is unverified, draft, summary data generated from a computer "word search" of customer and technician symptom comments. Supplier data, technician and customer comments are unverified and actual root cause of any potential issue is not established by this summary.

[Contact ODRHELP](#)

Copyright 2001 Ford Motor Co All Rights Reserved

PE12-019

Mazda

9-6-2012

REQUEST NUMBER THREE
DOCUMENTS (SUBJECT)

Consumer Reports

Mazda CAC

ECI

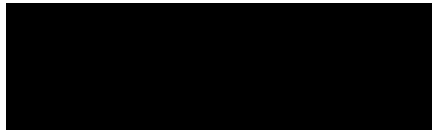



Concern Driven Reporting

Report Detail

Note: Field which are grayed (ghosted) are currently being mapped to the data warehouse. They are not presently being populated.

ECI Record		Source Code	MAZDA CAC
------------	--	-------------	-----------

Commodity Assignment			
Commodity	powertrain-engine	Symptom	mod-driving condition-at high rpm
Commodity	powertrain-engine	Symptom	no keyword found
Commodity	powertrain-engine	Symptom	pedal concerns-accelerator pedal
Commodity	powertrain-engine-accel pedal/linkage/controls	Symptom	field service action
Commodity	powertrain-engine-accel pedal/linkage/controls	Symptom	mod-driving condition-at high rpm
Commodity	powertrain-engine-accel pedal/linkage/controls	Symptom	pedal concerns-accelerator pedal
Commodity	powertrain-engine-accel pedal/linkage/controls	Symptom	sticks/binds/grabs
Significant Event		Verified	N

Tread Information	
Reported in Tread Quarter	Q4 2010

Report Details			
Source Claim Key		Warranty Component Classification (WCC)	
Corporate Product Systems Classification (CPSC)		Time in Service	67
Customer Condition Code		V Function Group (VFG)	
Source System Program Type		Repair/Report/Paid Date	09-Nov-2010
Version Series Code	AAAGH	Load Date	27-Dec-2010
Causal Part Prefix- Base - Suffix	-	Dealer Code	42090
Causal Part Name	unknown	Dealer Name	MAZDA OF ESCONDIDO
Non Causal Part Prefix-Base-Suffix		Dealer City	ESCONDIDO
Non Causal Part Numbers		Dealer State/Province	CA
Fault Code		Dealer Country	USA
Diagnostic Trouble Code		Dealer Phone Number	7607373275
Labor Operation Code		Attachment	
Communication Type		VOQ Component Description Code	
Maintenance Date	27-Dec-2010		

Customer Comment	CUSTOMER STATES THAT ACCELERATOR IS STICKING IN THE MORNING. NOTHING WILL HAPPEN WHEN GAS PEDAL IS PUSHED. WANTED TO CHECK RECALLS. HAS APOINMENT AT 42090 ON FRIDAY. TINA/WIFEMILAGE UNKNOWN ON CALL.
Technician Comment	ATTN DCSM/SVM PER CONVERSATION, PLEASE REVIEW REQUEST. PLEASE CONTACT THE DCSM FOR POSSIBLE GOODWILL. PLEASE CLOSE UPON RESOLUTION. THANKS. MARTIN 949 727 6697 CUSTOMER DID NOT SHOW FOR HIS APPOINTMENT. CONATCT SHOULD BE CLOSED. 0012010 11 09crpc802 AT ATTN DCSM/SVM PER CONVERSATION, PLEASE REVIEW REQUEST. PLEASE CONTACT THE DCSM FOR POSSIBLE GOODWILL. PLEASE CLOSE UPON RESOLUTION. THANKS. MARTIN 949 727 6697 REQ DESC ACCELERATOR CONCERN 0022010 11 24crpc802 LEFT VOICE MESSAGE WITH RONA AT DEALER. REQUESTED CALL BACK WITH INFORMATION. VM FROM RONA AT 42090. HAS NOT SEEN CUSTOMER AT DEALER SINCE 2008 0032010 11 26crpc802 CUSTOMER HAS NOT BROUGHT CAR IN FOR DIAGNOSIS 0042010 12 06crpc802 CUSTOMER DID NOT SHOW FOR HIS APPOINTMENT. CONATCT SHOULD BE CLOSED.
CQIS Recommendations	

Tire Information			
Tire Manufacturer	Unknown	Tire Size	Unknown
Tire Brand Series		Wheel	
DOT Left Front		DOT Right Front	
DOT Left Rear		DOT Right Rear	
DOT Left Inner		DOT Right Inner	
DOT Spare			

Vehicle Information			
VIN	4F2YZ02Z95K	Engine Serial Number	
Model Year	2005	Engine Description	2.3L DOHC EGI I4 I6V NA GAS
Transmission	4 SPD AUTO TRANS MAZDA CD4E	Vehicle Description	TRIBUTE
Body Cab Style	CA WE 5 DOOR LIGHT TRUCK	Drive Line	2 WHL L/H FRONT DRIVE
Production Date	07-Apr-2005	Retail Sale Indicator Code	
Plant Description	KANSAS CITY PLANT BUILD	Reaquired Vehicle	
Build Region		Warranty Start Date	14-May-2005
Build Country Code		Transmission Serial Number	
Mileage	0	Vehicle Axle Ratio	
Vehicle Restraint Code			

Disclaimer:

This data is for use as one of several potential "awareness" indicators for the Ford Motor Co. Enhanced Concern Identification System. It is unverified, draft, summary data generated from a computer "word search" of customer and technician symptom comments. Supplier data, technician and customer comments are unverified and actual root cause of any potential issue is not established by this summary.

[Contact ODRHELP](#)

Copyright 2001 Ford Motor Co All Rights Reserved

PE12-019

Mazda

9-6-2012

REQUEST NUMBER THREE
DOCUMENTS (SUBJECT)

Consumer Reports

Mazda CAC

ECI

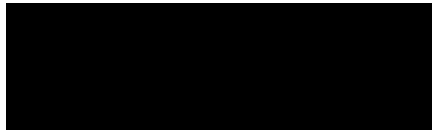



Concern Driven Reporting

Report Detail

Note: Field which are grayed (ghosted) are currently being mapped to the data warehouse. They are not presently being populated.

ECI Record		Source Code	MAZDA CAC
------------	--	-------------	-----------

Commodity Assignment			
Commodity	powertrain-engine	Symptom	no keyword found
Commodity	powertrain-engine-accel pedal/linkage/controls	Symptom	function-malfunction/inoperative
Commodity	powertrain-engine-accel pedal/linkage/controls	Symptom	pedal concerns-accelerator pedal
Commodity	powertrain-engine-accel pedal/linkage/controls	Symptom	sticks/binds/grabs
Significant Event		Verified	N

Tread Information	
Reported in Tread Quarter	Q1 2011

Report Details			
Source Claim Key		Warranty Component Classification (WCC)	
Corporate Product Systems Classification (CPSC)		Time in Service	39
Customer Condition Code		V Function Group (VFG)	
Source System Program Type		Repair/Report/Paid Date	11-Feb-2011
Version Series Code		Load Date	13 -Feb-2011
Causal Part Prefix- Base - Suffix	- -	Dealer Code	34602
Causal Part Name	unknown	Dealer Name	PADUCAH MAZDA
Non Causal Part Prefix-Base-Suffix		Dealer City	PADUCAH
Non Causal Part Numbers		Dealer State/Province	KY
Fault Code		Dealer Country	USA
Diagnostic Trouble Code		Dealer Phone Number	2704440011
Labor Operation Code		Attachment	
Communication Type		VOQ Component Description Code	
Maintenance Date	13 -Feb-2011		

Customer Comment	CUSTOMER STATES HIS THROTTLE HAS BEEN STICKING SINCE ONCTOBER, HE CALLED 34602 AND THEY THINK THE TROTTLER BODY NEEDS TO BE REPLACED, HOWEVER, HE HAS NOT HAD IT DIAGNOSED. THE CUSTOMER WOULD LIKE TO KNOW IF HE CAN GET ASSISTANCE.
Technician Comment	AGENT ADVISED CUSTOMER THAT HE WOULD NEED TO HAVE THE VEHICLE DIAGNOSED BEFORE ANY ASSISTANCE COULD BE PROVIDED. AGENT PROVIDED CUSTOMER WITH A FILE NUMBER AND EXTENSION WHICH DOCUMENTS THE CALL. 0012011 02 11crpc330 REQ DESC THOROTTLE BODY CONCERN AGENT ADVISED CUSTOMER THAT HE WOULD NEED TO HAVE THE VEHICLE DIAGNOSED BEFORE ANY ASSISTANCE COULD BE PROVIDED. AGENT PROVIDED CUSTOMER WITH A FILE NUMBER AND EXTENSION WHICH DOCUMENTS THE CALL.
CQIS Recommendations	

Tire Information			
Tire Manufacturer	Unknown	Tire Size	Unknown
Tire Brand Series		Wheel	
DOT Left Front		DOT Right Front	
DOT Left Rear		DOT Right Rear	
DOT Left Inner		DOT Right Inner	
DOT Spare			

Vehicle Information			
VIN	4F2CZ02Z18K	Engine Serial Number	031007164128
Model Year	2008	Engine Description	2.3L 4V DOHC EFI NA I4 GAS
Transmission	4 SPD AUTO TRANS NAAO CD4E	Vehicle Description	TRIBUTE
Body Cab Style	Unknown	Drive Line	2 WHL L/H FRONT DRIVE
Production Date	12-Oct-2007	Retail Sale Indicator Code	
Plant Description	KANSAS CITY PLANT BUILD	Reaquired Vehicle	
Build Region		Warranty Start Date	26-Dec-2007
Build Country Code		Transmission Serial Number	
Mileage	79400	Vehicle Axle Ratio	
Vehicle Restraint Code			

Disclaimer:

This data is for use as one of several potential "awareness" indicators for the Ford Motor Co. Enhanced Concern Identification System. It is unverified, draft, summary data generated from a computer "word search" of customer and technician symptom comments. Supplier data, technician and customer comments are unverified and actual root cause of any potential issue is not established by this summary.

[Contact ODRHELP](#)

Copyright 2001 Ford Motor Co All Rights Reserved

PE12-019

Mazda

9-6-2012

REQUEST NUMBER THREE
DOCUMENTS (SUBJECT)

Consumer Reports

Mazda CAC

ECI

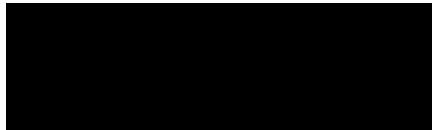



Concern Driven Reporting

Report Detail

Note: Field which are grayed (ghosted) are currently being mapped to the data warehouse. They are not presently being populated.

ECI Record		Source Code	MAZDA CAC
------------	--	-------------	-----------

Commodity Assignment

Commodity	powertrain-engine—	Symptom	field service action
Commodity	powertrain-engine-accel pedal/linkage/controls—	Symptom	field service action
Commodity	powertrain-engine-accel pedal/linkage/controls—	Symptom	mod-driving condition-while driving
Commodity	powertrain-engine-accel pedal/linkage/controls—	Symptom	pedal concerns-accelerator pedal
Commodity	powertrain-engine-accel pedal/linkage/controls—	Symptom	sticks/binds/grabs
Significant Event		Verified	N

Tread Information

Reported in Tread Quarter	Q3 2011
---------------------------	---------

Report Details

Source Claim Key		Warranty Component Classification (WCC)	
Corporate Product Systems Classification (CPS)		Time in Service	110
Customer Condition Code		V Function Group (VFG)	
Source System Program Type		Repair/Report/Paid Date	15-Sep-2011
Version Series Code	AAAA5	Load Date	18-Sep-2011
Causal Part Prefix-Base-Suffix	- -	Dealer Code	UNKNOW
Causal Part Name	unknown	Dealer Name	
Non Causal Part Prefix-Base-Suffix		Dealer City	
Non Causal Part Numbers		Dealer State/Province	
Fault Code		Dealer Country	USA
Diagnostic Trouble Code		Dealer Phone Number	
Labor Operation Code		Attachment	
Communication Type		VOQ Component Description Code	
Maintenance Date	18-Sep-2011		

Customer Comment	CUSTOMER'S FATHER STATED THE GAS PEDAL STICKS WHILE DRIVING. INQUIRE ABOUT RECALLS
Technician Comment	AGENT ADVISED CUSTOMER THERE ARE TWO OPEN RECALLS. RECOMMEND MAKING APPOINTMENT TO ADDRESS RECALLS. 0012011 09 17crpc816 REQ DESC GAS PEDAL
C Q I S Recommendations	

Tire Information

Tire Manufacturer	Unknown	Tire Size	Unknown
Tire Brand Series		Wheel	
DOT Left Front		DOT Right Front	
DOT Left Rear		DOT Right Rear	
DOT Left Inner		DOT Right Inner	
DOT Spare			

Vehicle Information

VIN	4F2YZ04103K	Engine Serial Number	552457086
Model Year	2003	Engine Description	3.0L DOHC EGI V6 NA*G DSP2967
Transmission	4 SPD AUTO TRANS MAZDA CD4E	Vehicle Description	TRIBUTE
Body Cab Style	CA WE 5 DOOR LIGHT TRUCK	Drive Line	2 WHL L/H FRONT DRIVE
Production Date	28-Aug-2002	Retail Sale Indicator Code	
Plant Description	KANSAS CITY PLANT BUILD	Required Vehicle	
Build Region		Warranty Start Date	19-Sep-2002
Build Country Code		Transmission Serial Number	
Mileage	177000	Vehicle Axle Ratio	
Vehicle Restraint Code			

Disclaimer:

This data is for use as one of several potential "awareness" indicators for the Ford Motor Co. Enhanced Concern Identification System. It is unverified, draft, summary data generated from a computer "word search" of customer and technician symptom comments. Supplier data, technician and customer comments are unverified and actual root cause of any potential issue is not established by this summary.

[Contact ODRHELP](#)

Copyright 2001 Ford Motor Co All Rights Reserved

PE12-019

Mazda

9-6-2012

REQUEST NUMBER THREE
DOCUMENTS (SUBJECT)

Consumer Reports

Mazda CAC

ECI

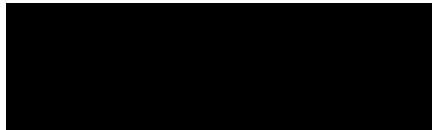



Concern Driven Reporting

Report Detail

Note: Field which are grayed (ghosted) are currently being mapped to the data warehouse. They are not presently being populated.

ECI Record		Source Code	MAZDA CAC
------------	--	-------------	-----------

Commodity Assignment

Commodity	powertrain-engine	Symptom	no keyword found
Commodity	powertrain-engine-accel pedal/linkage/controls	Symptom	function-malfunction/inoperative
Commodity	powertrain-engine-accel pedal/linkage/controls	Symptom	pedal concerns-accelerator pedal
Commodity	powertrain-engine-accel pedal/linkage/controls	Symptom	separation
Commodity	powertrain-engine-accel pedal/linkage/controls	Symptom	sticks/binds/grabs
Significant Event		Verified	N

Tread Information

Reported in Tread Quarter	Q4 2011
---------------------------	---------

Report Details

Source Claim Key		Warranty Component Classification (WCC)	
Corporate Product Systems Classification (CPSC)		Time in Service	42
Customer Condition Code		V Function Group (VFG)	
Source System Program Type		Repair/Report/Paid Date	09-Dec-2011
Version Series Code		Load Date	11-Dec-2011
Causal Part Prefix-Base-Suffix	-	Dealer Code	51502
Causal Part Name	unknown	Dealer Name	HERITAGE MAZDA OF BEL AIR
Non Causal Part Prefix-Base-Suffix		Dealer City	BEL AIR
Non Causal Part Numbers		Dealer State/Province	MD
Fault Code		Dealer Country	USA
Diagnostic Trouble Code		Dealer Phone Number	
Labor Operation Code		Attachment	
Communication Type		VOQ Component Description Code	
Maintenance Date	11-Dec-2011		

Customer Comment CUSTOMER STATED THE GAS PEDAL WENT STRIAIGHT TO THE FLOOR. DEALERSHIP STATED THROTTLE CABLE NEEDS TO BE REPLACED.

Technician Comment AGENT WILL APPROVE ONCE IN THE SYSTEM 0012011 12 09crpc816 REQ DESC THROTTLE CABLE AWA AGENT SPOKE WITH WILL, SERVICE ADVISOR WHO STATED THE CABLE BROKE BY THE GAS PEDAL. THE CABLE ENDED UP STUCK IN THE FIREWALL. WILL STATED THE PART HAD BEEN REPLACED ON IN 11/2010. AGENT POVIDED ONE TIME GOOD WILL TO COVER PARTS AND LABOR. WILL STATED THE PART AND LABOR COST \$160.90. AGENT WILL APPROVE ONCE IN THE SYSTEM

CQIS Recommendations

Tire Information

Tire Manufacturer	Unknown	Tire Size	P235/70R 16T BSW A S
Tire Brand Series		Wheel	
DOT Left Front		DOT Right Front	
DOT Left Rear		DOT Right Rear	
DOT Left Inner		DOT Right Inner	
DOT Spare			

Vehicle Information

VIN	4F2CZ96118K	Engine Serial Number	007524086050
Model Year	2008	Engine Description	MOD 3.0L DOHC EFI NA V6 G*NAAO
Transmission	4 SPD AUTO TRANS NAAO CD4E	Vehicle Description	TRIBUTE
Body Cab Style	Unknown	Drive Line	4 WHL L/H FULL TIME DRIVE
Production Date	23-Oct-2007	Retail Sale Indicator Code	
Plant Description	KANSAS CITY PLANT BUILD	Reaquired Vehicle	
Build Region		Warranty Start Date	24-Jul-2008
Build Country Code		Transmission Serial Number	100772850371
Mileage	19000	Vehicle Axle Ratio	
Vehicle Restraint Code			

Disclaimer:

This data is for use as one of several potential "awareness" indicators for the Ford Motor Co. Enhanced Concern Identification System. It is unverified, draft, summary data generated from a computer "word search" of customer and technician symptom comments. Supplier data, technician and customer comments are unverified and actual root cause of any potential issue is not established by this summary.

[Contact ODRHELP](#)

Copyright 2001 Ford Motor Co All Rights Reserved

PE12-019

Mazda

9-6-2012

REQUEST NUMBER THREE
DOCUMENTS (SUBJECT)

Consumer Reports

Mazda CAC

ECI

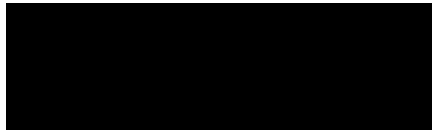



Concern Driven Reporting

Report Detail

Note: Field which are grayed (ghosted) are currently being mapped to the data warehouse. They are not presently being populated.

ECI Record		Source Code	MAZDA CAC
------------	--	-------------	-----------

Commodity Assignment			
Commodity	powertrain-engine	Symptom	field service action
Commodity	powertrain-engine	Symptom	no keyword found
Commodity	powertrain-engine	Symptom	pedal concerns-accelerator pedal
Commodity	powertrain-engine	Symptom	sticks/binds/grabs
Commodity	powertrain-engine	Symptom	unintended acceleration
Commodity	powertrain-engine-accel pedal/linkage/controls	Symptom	pedal concerns-accelerator pedal
Significant Event		Verified	N

Tread Information	
Reported in Tread Quarter	Q4 2011

Report Details			
Source Claim Key		Warranty Component Classification (WCC)	
Corporate Product Systems Classification (CPSC)		Time in Service	81
Customer Condition Code		V Function Group (VFG)	
Source System Program Type		Repair/Report/Paid Date	21-Dec-2011
Version Series Code	AAAGH	Load Date	25-Dec-2011
Causal Part Prefix-Base-Suffix	-	Dealer Code	UNKNOW
Causal Part Name	unknown	Dealer Name	
Non Causal Part Prefix-Base-Suffix		Dealer City	
Non Causal Part Numbers		Dealer State/Province	
Fault Code		Dealer Country	USA
Diagonstic Trouble Code		Dealer Phone Number	
Labor Operation Code		Attachment	
Communication Type		VOQ Component Description Code	
Maintenance Date	25-Dec-2011		

Customer Comment	CUSTOMER STATES THAT ACCELERATOR STICKS AND IT GOT STUCK IN AN ITERSECTION AND TOOK TO DEALER BUT THEY WANT TO CHARGE HER FOR DIAGNOSIS. WANTS TO KNOW IF THERE ARE ANY RECALLS.
Technician Comment	AGENT ADVISED THAT THERE ARE NO RECALLS AND THAT IT IS OUT OF WARRANTNY. SUGGESTED THAT SHE HAVE THE CAR DIAGNOSED AND WE CAN POSSIBLE HELP WITH AWA. 0012011 12 22CRPP286 REQ DESC ACCELERATOR PEDAL.
CQIS Recommendations	

Tire Information			
Tire Manufacturer	Unknown	Tire Size	Unknown
Tire Brand Series		Wheel	
DOT Left Front		DOT Right Front	
DOT Left Rear		DOT Right Rear	
DOT Left Inner		DOT Right Inner	
DOT Spare			

Vehicle Information			
VIN	4F2YZ02Z55K	Engine Serial Number	
Model Year	2005	Engine Description	2.3L DOHC EGI I4 16V NA GAS
Transmission	4 SPD AUTO TRANS MAZDA CD4E	Vehicle Description	TRIBUTE
Body Cab Style	CA WE 5 DOOR LIGHT TRUCK	Drive Line	2 WHL L/H FRONT DRIVE
Production Date	14-Apr-2005	Retail Sale Indicator Code	
Plant Description	KANSAS CITY PLANT BUILD	Required Vehicle	
Build Region		Warranty Start Date	14-May-2005
Build Country Code		Transmission Serial Number	
Mileage	46000	Vehicle Axle Ratio	
Vehicle Restraint Code			

Disclaimer:

This data is for use as one of several potential "awareness" indicators for the Ford Motor Co. Enhanced Concern Identification System. It is unverified, draft, summary data generated from a computer "word search" of customer and technician symptom comments. Supplier data, technician and customer comments are unverified and actual root cause of any potential issue is not established by this summary.

[Contact ODRHELP](#)

Copyright 2001 Ford Motor Co All Rights Reserved

PE12-019

Mazda

9-6-2012

REQUEST NUMBER THREE
DOCUMENTS (SUBJECT)

Consumer Reports

Mazda CAC

ECI

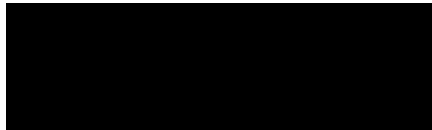



Concern Driven Reporting

Report Detail

Note: Field which are grayed (ghosted) are currently being mapped to the data warehouse. They are not presently being populated.

ECI Record		Source Code	MAZDA CAC
------------	--	-------------	-----------

Commodity Assignment			
Commodity	powertrain-engine	Symptom	battery-dead/weak
Commodity	powertrain-engine	Symptom	engine power-loss of power
Commodity	powertrain-engine	Symptom	field service action
Commodity	powertrain-engine	Symptom	function-malfunction/inoperative
Commodity	powertrain-engine	Symptom	no keyword found
Commodity	powertrain-engine	Symptom	pedal concerns-accelerator pedal
Commodity	powertrain-engine	Symptom	sticks/binds/grabs
Commodity	powertrain-engine-accel pedal/linkage/controls	Symptom	no keyword found
Commodity	powertrain-engine-accel pedal/linkage/controls	Symptom	pedal concerns-accelerator pedal
Commodity	powertrain-engine-accel pedal/linkage/controls	Symptom	repair-prior repair mentioned
Commodity	powertrain-engine-accel pedal/linkage/controls	Symptom	sticks/binds/grabs
Commodity	powertrain-engine-air induction-throttle body-	Symptom	no keyword found
Commodity	powertrain-engine-air induction-throttle body-	Symptom	repair-prior repair mentioned
Significant Event		Verified	N

Tread Information	
Reported in Tread Quarter	Q1 2012

Report Details			
Source Claim Key		Warranty Component Classification (WCC)	
Corporate Product Systems Classification (CPSC)		Time in Service	82
Customer Condition Code		V Function Group (VFG)	
Source System Program Type		Repair/Report/Paid Date	09-Jan-2012
Version Series Code	AAAGH	Load Date	16-Jan-2012
Causal Part Prefix-Base-Suffix	--	Dealer Code	50234
Causal Part Name	unknown	Dealer Name	MAPLE SHADE MAZDA TURNERSVILLE
Non Causal Part Prefix-Base-Suffix		Dealer City	SICKLERVILLE
Non Causal Part Numbers		Dealer State/Province	NJ
Fault Code		Dealer Country	USA
Diagnostic Trouble Code		Dealer Phone Number	8568750200
Labor Operation Code		Attachment	
Communication Type		VOQ Component Description Code	
Maintenance Date	24-Jan-2012		

Customer Comment CUSTOMER'S WIFE, FLORENCE, STATES HAS HAD ACCELERATOR STICK A COUPLE OF TIMES IN THE PAST TWO WEEKS AND IS INQUIRING IF VEHICLE HAS ANY OPEN RECALLS. ALSO STATES BRAKES ARE STICKING WHEN UNABLE TO ACCELERATE. STATES IS CONSIDERING CALLING DEALER TO SCHEDULE AN APPOINTMENT BUT NOT SURE BECAUSE OF THE COST OF PAYING A DIAGNOSTIC

Technician Comment ADVISED CUSTOMER NO OPEN RECALLS AND ADVISED CUSTOMER TO SCHEDULE AN APPOINTMENT WITH LOCAL AUTHORIZED MAZDA DEALER. ADVISED CUSTOMER THROTTLE BODY NEEDS CLEANING, WHICH IS A NORMAL MAINTENANCE ITEM AND NOT COVERED UNDER WARRANTY. ADVISED CUSTOMER THE LAST TIME THROTTLE BODY WAS CLEANED WAS IN 2007 AT 21K. 0012012 01 09CRPC427 REQ DESC RECALL INQUIRY ACCELERATOR PEDAL ADVISED CUSTOMER NO OPEN RECALLS AND ADVISED CUSTOMER TO SCHEDULE AN APPOINTMENT WITH LOCAL AUTHORIZED MAZDA DEALER. 0022012 01 10CRPP206 WIFE CALLED BACK AGAIN AND STATES FOUND INVOICES OF WHERE VEHICLE WAS TAKEN TO DEALER FOR GAS PEDAL STICKING PREVIOUSLY. WIFE STATES HAS AN APPOINTMENT WITH DEALER NEXT WEDNESDAY AND INQUIRED WHAT SHE SHOULD DO. WIFE STATES VEHICLE IS SAFE TO DRIVE AND SHE WILL DRIVE VEHICLE TO DEALERSHIP. ADVISED SHE SHOULD HAVE DEALER LOOK AT VEHICLE FOR CONCERN. ADVISED OF FILE NUMBER [REDACTED] 1 18CRPP206 WIFE CALLED BACK AND STATES VEHICLE IS AT DEALER NOW AND NEEDS \$500 WORTH OF THROTTLE WORK ON THE VEHICLE. CUSTOMER STATES SINCE THIS HAS BEEN ADDRESSED THREE TIMES BEFORE DOESNT FEEL SHE SHOULD HAVE TO PAY FOR THE REPAIR. 0042012 01 18crpc155 CUSTOMER FLORENCE CALLING BACK, IS COMPLAINING OF MULTIPLE BATTERY ISSUES WITH HER CAR. CUSTOMER WANTS TO KNOW CAN A BATTERY GO BAD THAT FAST AGENT ADVISED CANNOT SAY, WE ARE NOT TRAINED MECHANICS, TECHNICAL EXPLANATION WOULD NEED TO COME FROM THE DEALER. AGENT ADVISED GLYNN STILL WORKING ON HER CASE AND WILL CALL YOU BACK IF YOU CALLED HER. CUSTOMER STATES GOOD # AFTER 2PM IS [REDACTED] AGENT SENT CHAT NOTE TO GLYNN. 0052012 01 18CRPC427 CUSTOMER CALLING FOR GLYNN. TRANSFERRED CALL WITH PERMISSION. 0062012 01 18CRPP206 TALKED TO BRENT, SERVICE ADVISOR AT DEALERSHIP, WHO STATES LAST TIME VEHICLE WAS IN FOR THIS CONCERN WAS IN 2007 @ 21K. BRENT STATES THROTTLE BODY NEEDS SERVICING, WHICH IS A NORMAL MAINTENANCE ITEM. ADVISED CUSTOMER THROTTLE BODY NEEDS CLEANING, WHICH IS A NORMAL MAINTENANCE ITEM AND NOT COVERED UNDER WARRANTY. ADVISED CUSTOMER THE LAST TIME THROTTLE BODY WAS CLEANED WAS IN 2007 AT 21K.

CQIS Recommendations	
----------------------	--

Tire Information			
Tire Manufacturer	Unknown	Tire Size	Unknown
Tire Brand Series		Wheel	

DOT Left Front		DOT Right Front	
DOT Left Rear		DOT Right Rear	
DOT Left Inner		DOT Right Inner	
DOT Spare			

Vehicle Information

VIN	4F2YZ02Z25K [REDACTED]	Engine Serial Number	
Model Year	2005	Engine Description	2.3L DOHC EGI I4 16V NA GAS
Transmission	4 SPD AUTO TRANS MAZDA CD4E	Vehicle Description	TRIBUTE
Body Cab Style	CA WE 5 DOOR LIGHT TRUCK	Drive Line	2 WHL L/H FRONT DRIVE
Production Date	24-Mar-2005	Retail Sale Indicator Code	
Plant Description	KANSAS CITY PLANT BUILD	Required Vehicle	
Build Region		Warranty Start Date	27-Apr-2005
Build Country Code		Transmission Serial Number	
Mileage	48000	Vehicle Axle Ratio	
Vehicle Restraint Code			

Disclaimer:

This data is for use as one of several potential "awareness" indicators for the Ford Motor Co. Enhanced Concern Identification System. It is unverified, draft, summary data generated from a computer "word search" of customer and technician symptom comments. Supplier data, technician and customer comments are unverified and actual root cause of any potential issue is not established by this summary.

[Contact CDR HELP](#)

Copyright 2001 Ford Motor Co. All Rights Reserved

PE12-019

Mazda

9-6-2012

REQUEST NUMBER THREE
DOCUMENTS (SUBJECT)

Consumer Reports

Mazda CAC

ECI

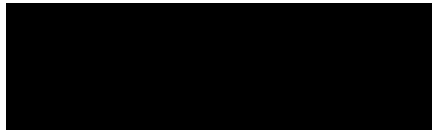



Concern Driven Reporting

Report Detail

Note: Field which are grayed (ghosted) are currently being mapped to the data warehouse. They are not presently being populated.

ECI Record		Source Code	MAZDA CAC
------------	--	-------------	-----------

Commodity Assignment

Commodity	powertrain-engine	Symptom	damage-cracked/fractured/split
Commodity	powertrain-engine	Symptom	function-malfunction/inoperative
Commodity	powertrain-engine	Symptom	high effort
Commodity	powertrain-engine	Symptom	improper assembly
Commodity	powertrain-engine	Symptom	no keyword found
Commodity	powertrain-engine	Symptom	separation
Commodity	powertrain-engine-accel pedal/linkage/controls	Symptom	function-malfunction/inoperative
Commodity	powertrain-engine-accel pedal/linkage/controls	Symptom	high effort
Commodity	powertrain-engine-accel pedal/linkage/controls	Symptom	improper assembly
Commodity	powertrain-engine-accel pedal/linkage/controls	Symptom	mod-driving condition-while driving
Commodity	powertrain-engine-accel pedal/linkage/controls	Symptom	pedal concerns-accelerator pedal
Commodity	powertrain-engine-accel pedal/linkage/controls	Symptom	separation
Significant Event		Verified	N

Tread Information

Reported in Tread Quarter	Q1 2012
---------------------------	---------

Report Details

Source Claim Key		Warranty Component Classification (WCC)	
Corporate Product Systems Classification (CPSC)		Time in Service	46
Customer Condition Code		V Function Group (VFG)	
Source System Program Type		Repair/Report/Paid Date	26-Mar-2012
Version Series Code		Load Date	01-Apr-2012
Causal Part Prefix- Base - Suffix	- -	Dealer Code	34662
Causal Part Name	unknown	Dealer Name	MAZDA OF MESQUITE
Non Causal Part Prefix-Base-Suffix		Dealer City	MESQUITE
Non Causal Part Numbers		Dealer State/Province	TX
Fault Code		Dealer Country	USA
Diagnostic Trouble Code		Dealer Phone Number	
Labor Operation Code		Attachment	
Communication Type		VOQ Component Description Code	
Maintenance Date	01-Apr-2012		

Customer Comment	CUSTOMER DRIVING VEHICLE AND GAS PEDAL/THROTTLE CABLE BROKE. CUSTOMER STATES DEALER SAID CABLE WAS NOT BUILT PROPERLY AND THAT IS WHY IT BROKE, IS ASKING FOR REPAIR ASSISTANCE TO PAY FOR REPAIRS. CUSTOMER FEELS THIS IS A SAFETY CONCERN. CAR IS DOWN AT MAZDA OF MESQUITE. PART WILL BE IN TODAY AT 2PM, I AM TRAVELLING AND ONLY HERE FOR TODAY.
------------------	---

Technician Comment	<p>ATTN DCSM/SVM PER CONVERSATION, PLEASE REVIEW REQUEST. PLEASE CONTACT THE DCSM FOR POSSIBLE GOODWILL. PLEASE CLOSE UPON RESOLUTION. THANKS. SENT CARD TO CUSTOMER TODAYMARCH 29, 2012BRETT SWETT1003 HURON AVELUBBOCK, TX 79416RE FILE NUMBER [REDACTED] VIN 4F2CZ06168K [REDACTED] VEHICLE 2008 TRIBUTEDEAR MR. [REDACTED] THANK YOU FOR CONTACTING MAZDA REGARDING YOUR 2008 MAZDA TRIBUTE.FIRST, LET ME SAY THAT IT IS NEVER OUR INTENTION TO HAVE ANYONE LESS THAN COMPLETELY SATISFIED WITH ANY ASPECT OF HIS OR HER MAZDA OWNERSHIP EXPERIENCE. I APOLOGIZE FOR ANY INCONVENIENCE OR FRUSTRATION WITH YOUR WHEEL HUBCAPS.AS 0012012 03 26crpc155 AT ATTN DCSM/SVM PER CONVERSATION, PLEASE REVIEW REQUEST. PLEASE CONTACT THE DCSM FOR POSSIBLE GOODWILL. PLEASE CLOSE UPON RESOLUTION. THANKS. REQ DESC AWA THROTTLE CABLE AGENT ADVISED WILL REVIEW FOR AWA AND CONTACT BACK REGARDING THIS CONCERN. PLEASE GIVE ME TIME TO REVIEW AND I WILL BE IN TOUCH. CALLED DSM MELODY, ADVISED STATUS AND CUSTOMER REQUEST. WILL EMAIL UPDATE AND DISPATCH. 0022012 03 26crpc155 HI MELODY,CUSTOMER CALLED US TODAY. CAR IS DOWN IN THE SHOP, NEEDS THROTTLE CABLE. CUSTOMER ASKING FOR WARRANTY ASSISTANCE, WORKING WITH MIKE J. COULD YOU PLEASE REVIEW AND ADVISE [REDACTED] [REDACTED] TRIBUTEMAZDA OF MESQUITE 34662THANKS, CALLED DSM MELODY, LEFT MESSAGE FOR CALL BACK. CALLED MIKE J AT MAZDA, ADVISED DID NOT SAY WHAT CUSTOMER SAID. CUSTOMER TRAVELLING AND WE ARE PUTTING A FORD PART ON THE CAR, CANNOT GET A MAZDA CABLE UNTIL TOMORROW CUSTOMER DOES 0032012 03 26crpc155 NOT WANT TO STAY. ADVISED WILL OFFER GIFT CARD TO CUSTOMER, BUT NO FURTHER BECAUSE NON MAZDA PARTS AND DSM DECLINED TO ASSIST. CALLED CUSTOMER ADVISED WITH THE CURRENT SITUATION, WILL OFFER MAZDA GIFT CARDS FOR INCONVENIENCE. CANNOT ASSIST DIRECTLY BECAUSE THE REPAIR IS USING A FORD PART. WILL DOCUMENT THIS AS A SAFETY CONCERN PER YOUR REQUEST. ADVISED AWA PROCEDURE FOR MAZDA AND WILL SEND OUT \$75.00 IN GIFT CARDS TO CUSTOMER. 0042012 03 26crpc155 DSM MELODY CALLED AGENT, DISCUSSED WITH SERVICE MANAGER AT DEALER, DO NOT FEEL THEY WOULD VERBALLY EXPLAIN THIS TO THE CUSTOMER IN THE WAY HE DESCRIBED. ADVISED NOT INCLINED TO ASSIST DUE TO TRAVELLING CUSTOMER, BUT OK IF YOU WANT TO ASSIST OR PROVIDE GIFT CARDS. AGENT ADVISED WILL REVIEW AND CONTACT DEALER AND CUSTOMER. SENT TO MANAGEMENT AS FYI.CAC# [REDACTED] 8 TRIBUTE [REDACTED] OF MESQUITE 34662GULF REGIONCOMPLAINT CUSTOMER BRETT DRIVING VEHICLE AND GAS PEDAL/THROTTLE 0052012 03 26crpc155 CABLE BROKE. CUSTOMER STATES DEALER SAID CABLE WAS NOT BUILT PROPERLY AND THAT IS WHY IT BROKE, IS ASKING FOR REPAIR ASSISTANCE TO PAY FOR REPAIRS. CUSTOMER FEELS THIS IS A SAFETY CONCERN. CAR IS DOWN AT MAZDA OF MESQUITE. PART WILL BE IN TODAY AT 2PM, I AM TRAVELLING AND ONLY HERE FOR REPAIRS TODAY. 541.680.3705THANKS, 0062012 03 29crpc155 SENT CARD TO CUSTOMER TODAYMARCH 29, 2012 [REDACTED] 1003 HURON AVELUBBOCK, TX 79416RE FILE NUMBER [REDACTED] VIN 4F2CZ06168K [REDACTED] VEHICLE 2008 TRIBUTEDEAR MR. [REDACTED], THANK YOU FOR CONTACTING MAZDA REGARDING YOUR 2008 MAZDA TRIBUTE.FIRST, LET ME SAY THAT IT IS NEVER OUR INTENTION TO HAVE ANYONE LESS THAN COMPLETELY SATISFIED WITH ANY ASPECT OF HIS OR HER MAZDA OWNERSHIP EXPERIENCE. I APOLOGIZE FOR ANY INCONVENIENCE OR FRUSTRATION WITH YOUR WHEEL HUBCAPS.AS A GOODWILL GESTURE, ENCLOSED PLEASE FIND TWO (2) GIFT CERTIF 0072012 03 29crpc155 ICATE CARDS FOR \$30.00 AND \$45.00, TOTALING \$75.00. THESE MAY BE USED AT ANY MAZDA DEALER FOR PARTS OR SERVICES. PLEASE UNDERSTAND THIS GESTURE OF GOODWILL EMPHASIZES THAT YOUR INPUT AND CUSTOMER LOYALTY ARE GREATLY APPRECIATED. THANK YOU AGAIN FOR SPEAKING WITH ME ABOUT YOUR MAZDA OWNERSHIP EXPERIENCE. IF I CAN BE OF ANY FURTHER ASSISTANCE PLEASE CALL ME AT 800 222 5500, X1153. BEST REGARDS,TRAVISREPRESENTATIVE, CUSTOMER ASSISTANCE CENTERMAZDA NORTH AMERICAN OPERATIONS</p>
CQIS Recommendation	

Tire Information

Tire Manufacturer	Unknown	Tire Size	P235/70R 16T BSW A S
Tire Brand Series		Wheel	
DOT Left Front		DOT Right Front	
DOT Left Rear		DOT Right Rear	
DOT Left Inner		DOT Right Inner	
DOT Spare			

Vehicle Information

VIN	4F2CZ06168K [REDACTED]	Engine Serial Number	I08579832050
Model Year	2008	Engine Description	MOD 3.0L DOHC EFI NA V6 G*NAAO
Transmission	4 SPD AUTO TRANS NAAO CD4E	Vehicle Description	TRIBUTE
Body Cab Style	Unknown	Drive Line	2 WHL L/H FRONT DRIVE
Production Date	16-Jan-2008	Retail Sale Indicator Code	
Plant Description	KANSAS CITY PLANT BUILD	Reaquired Vehicle	
Build Region		Warranty Start Date	28-Jun-2008
Build Country Code		Transmission Serial Number	010880040424
Mileage	60000	Vehicle Axle Ratio	
Vehicle Restraint Code			

Disclaimer:

This data is for use as one of several potential "awareness" indicators for the Ford Motor Co. Enhanced Concern Identification System. It is unverified, draft, summary data generated from a computer "word search" of customer and technician symptom comments. Supplier data, technician and customer comments are unverified and actual root cause of any potential issue is not established by this summary.

PE12-019

Mazda

9-6-2012

REQUEST NUMBER THREE
DOCUMENTS (SUBJECT)

Consumer Reports

Mazda CAC

ECI

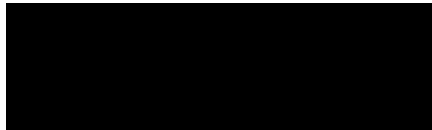



Concern Driven Reporting

Report Detail

Note: Field which are grayed (ghosted) are currently being mapped to the data warehouse. They are not presently being populated.

ECI Record		Source Code	MAZDA CAC
------------	--	-------------	-----------

Commodity Assignment

Commodity	powertrain-engine	Symptom	field service action
Commodity	powertrain-engine-accel pedal/linkage/controls	Symptom	field service action
Commodity	powertrain-engine-accel pedal/linkage/controls	Symptom	mod-driving condition-while driving
Commodity	powertrain-engine-accel pedal/linkage/controls	Symptom	pedal concerns-accelerator pedal
Commodity	powertrain-engine-accel pedal/linkage/controls	Symptom	sticks/binds/grabs
Significant Event		Verified	N

Tread Information

Reported in Tread Quarter	Q2 2012
---------------------------	---------

Report Details

Source Claim Key		Warranty Component Classification (WCC)	
Corporate Product Systems Classification (CPSC)		Time in Service	112
Customer Condition Code		V Function Group (VFG)	
Source System Program Type		Repair/Report/Paid Date	23-Apr-2012
Version Series Code	AAAA5	Load Date	01-May-2012
Causal Part Prefix - Base - Suffix	- -	Dealer Code	UNKNOW
Causal Part Name	unknown	Dealer Name	
Non Causal Part Prefix-Base-Suffix		Dealer City	
Non Causal Part Numbers		Dealer State/Province	
Fault Code		Dealer Country	USA
Diagnostic Trouble Code		Dealer Phone Number	
Labor Operation Code		Attachment	
Communication Type		VOQ Component Description Code	
Maintenance Date	01-May-2012		

Customer Comment CUSTOMER STATES HE WAS DRIVING AND THE THROTTLE STUCK ALMOST RESULTING IN AN ACCIDENT. CUSTOMER STATES HE WOULD LIKE TO DOCUMENT THE CONCERN.

Technician Comment AGENT APOLOGIZED FOR THE INCONVENIENCE AND PROVIDED FILE NUMBER. AGENT SUGGESTED TO HAVE THE VEHICLE DIAGNOSED BY THE LOCAL MAZDA DEALERSHIP FOR POSSIBLE REPAIRS/ RECALL COMPLETION. AGENT ADVISED OF OPEN RECALL. 0012012 04 23CRPC815 REQ DESC THROTTLE STICK AGENT APOLOGIZED FOR THE INCONVENIENCE AND PROVIDED FILE NUMBER. AGENT SUGGESTED TO HAVE THE VEHICLE DIAGNOSED BY THE LOCAL MAZDA DEALERSHIP FOR POSSIBLE REPAIRS/ RECALL COMPLETION. AGENT ADVISED OF OPEN RECALL.

CQIS Recommendations

Tire Information

Tire Manufacturer	Unknown	Tire Size	Unknown
Tire Brand Series		Wheel	
DOT Left Front		DOT Right Front	
DOT Left Rear		DOT Right Rear	
DOT Left Inner		DOT Right Inner	
DOT Spare			

Vehicle Information

VIN	4F2YZ04113K	Engine Serial Number	
Model Year	2003	Engine Description	3.0L DOHC EGI V6 NA*G DSP2967
Transmission	4 SPD AUTO TRANS MAZDA CD4E	Vehicle Description	TRIBUTE
Body Cab Style	CA WE 5 DOOR LIGHT TRUCK	Drive Line	2 WHL L/H FRONT DRIVE
Production Date	22-Oct-2002	Retail Sale Indicator Code	
Plant Description	KANSAS CITY PLANT BUILD	Reaquired Vehicle	
Build Region		Warranty Start Date	27-Feb-2003
Build Country Code		Transmission Serial Number	
Mileage	190000	Vehicle Axle Ratio	
Vehicle Restraint Code			

Disclaimer:

This data is for use as one of several potential "awareness" indicators for the Ford Motor Co. Enhanced Concern Identification System. It is unverified, draft, summary data generated from a computer "word search" of customer and technician symptom comments. Supplier data, technician and customer comments are unverified and actual root cause of any potential issue is not established by this summary.

[Contact ODRHELP](#)

Copyright 2001 Ford Motor Co All Rights Reserved

PE12-019

Mazda

9-6-2012

REQUEST NUMBER THREE
DOCUMENTS (SUBJECT)

Consumer Reports

Mazda CAC

ECI

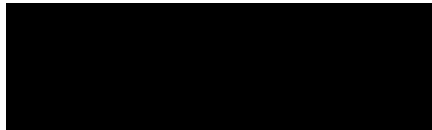



Concern Driven Reporting

Report Detail

Note: Field which are grayed (ghosted) are currently being mapped to the data warehouse. They are not presently being populated.

ECI Record		Source Code	MAZDA Care Surveys
------------	--	-------------	--------------------

Commodity Assignment

Commodity	powertrain-engine-accel pedal/linkage/controls	Symptom	function-malfunction/inoperative
Commodity	powertrain-engine-accel pedal/linkage/controls	Symptom	misaligned/out of position/adjustment/poor fit
Commodity	powertrain-engine-accel pedal/linkage/controls	Symptom	mod-driving condition-while driving
Commodity	powertrain-engine-accel pedal/linkage/controls	Symptom	pedal concerns-accelerator pedal
Significant Event		Verified	N

Tread Information

Reported in Tread Quarter Q4 2005

Report Details

Source Claim Key		Warranty Component Classification (WCC)	
Corporate Product Systems Classification (CPS)		Time in Service	2
Customer Condition Code		V Function Group (VFG)	
Source System Program Type		Repair/Report/Paid Date	18-Oct-2005
Version Series Code	AAAGH	Load Date	13-Nov-2005
Causal Part Prefix- Base - Suffix	-	Dealer Code	51435
Causal Part Name	NOT PROVIDED BY SOURCE	Dealer Name	QUIRK MAZDA
Non Causal Part Prefix-Base-Suffix		Dealer City	QUINCY
Non Causal Part Numbers		Dealer State/Province	MA
Fault Code		Dealer Country	USA
Diagnostic Trouble Code		Dealer Phone Number	
Labor Operation Code		Attachment	
Communication Type		VOQ Component Description Code	
Maintenance Date	13-Nov-2005		

Customer Comment
 Experienced problem with engine revving unable to stop without manually adjusting gas pedal, (no, mat NOT the issue), talked to service manager. Dislike the big gun having to come talk to you after initial talk with salesperson degrading" They go back to the huddle to chat about your credit, etc., then back to you. Then the credit big gun appears. Salesperson appears unable to handle these things too many players" BUT drove my last Mazda for 123,000 miles without ANY problems. That's why I came back to Mazda. (Bottom of front) Lewis at Mazda, Quincy, MA was the low key, non aggressive salesperson I was looking for. I would have walked away from the typical macho salesman"

Technician Comment
CQIS Recommendations

Tire Information

Tire Manufacturer	Unknown	Tire Size	Unknown
Tire Brand Series		Wheel	
DOT Left Front		DOT Right Front	
DOT Left Rear		DOT Right Rear	
DOT Left Inner		DOT Right Inner	
DOT Spare			

Vehicle Information

VIN	4F2YZ02Z96K	Engine Serial Number	
Model Year	2006	Engine Description	2.3L DOHC EGI I4 I6V NA GAS
Transmission	4 SPD AUTO TRANS MAZDA CD4E	Vehicle Description	TRIBUTE
Body Cab Style	CA WE 5 DOOR LIGHT TRUCK	Drive Line	2 WHL L/H FRONT DRIVE
Production Date	28-Jul-2005	Retail Sale Indicator Code	
Plant Description	KANSAS CITY PLANT BUILD	Required Vehicle	
Build Region		Warranty Start Date	17-Sep-2005
Build Country Code		Transmission Serial Number	
Mileage	0	Vehicle Axle Ratio	
Vehicle Restraint Code			

Disclaimer:

This data is for use as one of several potential "awareness" indicators for the Ford Motor Co. Enhanced Concern Identification System. It is unverified, draft, summary data generated from a computer "word search" of customer and technician symptom comments. Supplier data, technician and customer comments are unverified and actual root cause of any potential issue is not established by this summary.

[Contact ODRHELP](#)

Copyright 2001 Ford Motor Co All Rights Reserved

PE12-019

Mazda

9-6-2012

REQUEST NUMBER THREE
DOCUMENTS (SUBJECT)

Consumer Reports

Mazda CAC

ECI

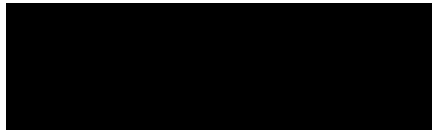



Concern Driven Reporting

Report Detail

Note: Field which are grayed (ghosted) are currently being mapped to the data warehouse. They are not presently being populated.

ECI Record		Source Code	MAZDA Care Surveys
------------	--	-------------	--------------------

Commodity Assignment			
Commodity	powertrain-engine-accel pedal/linkage/controls	Symptom	mod-intermittent/random
Commodity	powertrain-engine-accel pedal/linkage/controls	Symptom	pedal concerns-accelerator pedal
Significant Event		Verified	N

Tread Information	
Reported in Tread Quarter	Q1 2006

Report Details			
Source Claim Key		Warranty Component Classification (WCC)	
Corporate Product Systems Classification (CPSC)		Time in Service	37
Customer Condition Code		V Function Group (VFG)	
Source System Program Type		Repair/Report/Paid Date	14-Jan-2006
Version Series Code	AAAA5	Load Date	16-Feb-2006
Causal Part Prefix-Base-Suffix	-	Dealer Code	23877
Causal Part Name	NOT PROVIDED BY SOURCE	Dealer Name	ACCARDI MAZDA
Non Causal Part Prefix-Base-Suffix		Dealer City	LAKE CITY
Non Causal Part Numbers		Dealer State/Province	FL
Fault Code		Dealer Country	USA
Diagnostic Trouble Code		Dealer Phone Number	3867526933
Labor Operation Code		Attachment	
Communication Type		VOQ Component Description Code	
Maintenance Date	16-Feb-2006		

Customer Comment	After receiving a recall notice from Mazda about my 2003 Tribute, I brought it to Eddie Accardi Mazda in Lake City Florida, where I purchased the vehicle and routinely bring it for periodic oil changes and tire rotations. I was told by the service writer that my vehicle was not on the recall list and no recall service was necessary. About two months later I experienced a runaway engine while on the road and fortunately was able to drive the vehicle with much difficulty to Duval Mazda in Gainesville, Florida where the accelerator linkage was replaced as a recall item. This was a scary and dangerous experience as a result of Accardi Mazda's service writer's negligence. Dr. Olga Dreeben
Technician Comment	
CQIS Recommendations	

Tire Information			
Tire Manufacturer	Unknown	Tire Size	Unknown
Tire Brand Series		Wheel	
DOT Left Front		DOT Right Front	
DOT Left Rear		DOT Right Rear	
DOT Left Inner		DOT Right Inner	
DOT Spare			

Vehicle Information			
VIN	4F2YZ04163K	Engine Serial Number	
Model Year	2003	Engine Description	3.0L DOHC EGI V6 NA*G DSP2967
Transmission	4 SPD AUTO TRANS MAZDA CD4E	Vehicle Description	TRIBUTE
Body Cab Style	CA WE 3 DOOR LIGHT TRUCK	Drive Line	2 WHL L/H FRONT DRIVE
Production Date	11-Dec-2002	Retail Sale Indicator Code	
Plant Description	KANSAS CITY PLANT BUILD	Required Vehicle	
Build Region		Warranty Start Date	23-Jan-2003
Build Country Code		Transmission Serial Number	
Mileage	0	Vehicle Axle Ratio	
Vehicle Restraint Code			

Disclaimer:

This data is for use as one of several potential "awareness" indicators for the Ford Motor Co. Enhanced Concern Identification System. It is unverified, draft, summary data generated from a computer "word search" of customer and technician symptom comments. Supplier data, technician and customer comments are unverified and actual root cause of any potential issue is not established by this summary.

[Contact ODRHELP](#)

Copyright 2001 Ford Motor Co All Rights Reserved

PE12-019

Mazda

9-6-2012

REQUEST NUMBER THREE
DOCUMENTS (SUBJECT)

Consumer Reports

Mazda CAC

ECI

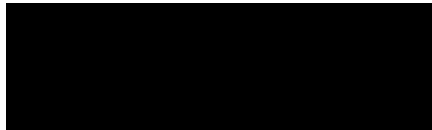



Concern Driven Reporting

Report Detail

Note: Field which are grayed (ghosted) are currently being mapped to the data warehouse. They are not presently being populated.

ECI Record		Source Code	MAZDA Care Surveys
------------	--	-------------	--------------------

Commodity Assignment			
Commodity	powertrain-engine-accel pedal/linkage/controls	Symptom	function-malfunction/inoperative
Commodity	powertrain-engine-accel pedal/linkage/controls	Symptom	mod-driving condition-on grade
Commodity	powertrain-engine-accel pedal/linkage/controls	Symptom	nvh-noisy operation
Commodity	powertrain-engine-accel pedal/linkage/controls	Symptom	pedal concerns-accelerator pedal
Commodity	powertrain-engine-accel pedal/linkage/controls	Symptom	pedal concerns-pedal positions
Significant Event		Verified	N

Tread Information	
Reported in Tread Quarter	Q1 2006

Report Details			
Source Claim Key		Warranty Component Classification (WCC)	
Corporate Product Systems Classification (CPSC)		Time in Service	68
Customer Condition Code		V Function Group (VFG)	
Source System Program Type		Repair/Report/Paid Date	03-Mar-2006
Version Series Code	AAAAAX	Load Date	11-Apr-2006
Causal Part Prefix-Base-Suffix	-	Dealer Code	51565
Causal Part Name	NOT PROVIDED BY SOURCE	Dealer Name	VARNEY MAZDA
Non Causal Part Prefix-Base-Suffix		Dealer City	BANGOR
Non Causal Part Numbers		Dealer State/Province	ME
Fault Code		Dealer Country	USA
Diagnostic Trouble Code		Dealer Phone Number	2079901200
Labor Operation Code		Attachment	
Communication Type		VOQ Component Description Code	
Maintenance Date	11-Apr-2006		

Customer Comment	We have experienced some kind of engine or transmission noise, especially when going up hill or changing speed. Having some of the coils replaced seemed to help. If the noise is in the transmission, it could be part of the normal running. Before taking the car into the garage, when you stepped on the gas from a standing position, it was very sensitive; either would not go or took off like rocket. Now the gas pedal works very good. Overall, we have enjoyed the car.
Technician Comment	
CQIS Recommendations	

Tire Information			
Tire Manufacturer	Unknown	Tire Size	Unknown
Tire Brand Series		Wheel	
DOT Left Front		DOT Right Front	
DOT Left Rear		DOT Right Rear	
DOT Left Inner		DOT Right Inner	
DOT Spare			

Vehicle Information			
VIN	4F2YU06171K	Engine Serial Number	
Model Year	2001	Engine Description	3.0L DOHC EGI V6 NA*GAS
Transmission	4 SPD AUTO TRANS MAZDA CD4E	Vehicle Description	TRIBUTE
Body Cab Style	CA WE 5 DOOR LIGHT TRUCK	Drive Line	4 WHL L/H PART TIME DRIVE
Production Date	29-Jun-2000	Retail Sale Indicator Code	
Plant Description	KANSAS CITY PLANT BUILD	Required Vehicle	
Build Region		Warranty Start Date	31-Aug-2000
Build Country Code		Transmission Serial Number	
Mileage	0	Vehicle Axle Ratio	
Vehicle Restraint Code			

Disclaimer:

This data is for use as one of several potential "awareness" indicators for the Ford Motor Co. Enhanced Concern Identification System. It is unverified, draft, summary data generated from a computer "word search" of customer and technician symptom comments. Supplier data, technician and customer comments are unverified and actual root cause of any potential issue is not established by this summary.

[Contact ODRHELP](#)

Copyright 2001 Ford Motor Co All Rights Reserved

PE12-019

Mazda

9-6-2012

REQUEST NUMBER THREE
DOCUMENTS (SUBJECT)

Consumer Reports

Mazda CAC

ECI

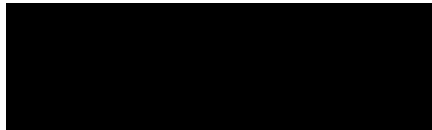



Concern Driven Reporting

Report Detail

Note: Field which are grayed (ghosted) are currently being mapped to the data warehouse. They are not presently being populated.

ECI Record		Source Code	MAZDA Care Surveys
------------	--	-------------	--------------------

Commodity Assignment

Commodity	powertrain-engine-accel pedal/linkage/controls	Symptom	pedal concerns-accelerator pedal
Commodity	powertrain-engine-accel pedal/linkage/controls	Symptom	sticks/binds/grabs
Significant Event		Verified	N

Tread Information

Reported in Tread Quarter	Q1 2007
---------------------------	---------

Report Details

Source Claim Key		Warranty Component Classification (WCC)	
Corporate Product Systems Classification (CPSC)		Time in Service	26
Customer Condition Code		V Function Group (VFG)	
Source System Program Type		Repair/Report/Paid Date	20-Jan-2007
Version Series Code	AAAGH	Load Date	07-Apr-2007
Causal Part Prefix- Base - Suffix	-	Dealer Code	UNKNOW
Causal Part Name	NOT PROVIDED BY SOURCE	Dealer Name	
Non Causal Part Prefix-Base-Suffix		Dealer City	
Non Causal Part Numbers		Dealer State/Province	
Fault Code		Dealer Country	USA
Diagnostic Trouble Code		Dealer Phone Number	
Labor Operation Code		Attachment	
Communication Type		VOQ Component Description Code	
Maintenance Date	07-Apr-2007		

Customer Comment	CUSTOMER STATED HIS GAS PEDAL STICKS. HE SAID HE WAS TOLD IT WAS DUE TO HIS FLOOR MATS. HE SAID AFTER TAKING THEM OUT, THE PEDAL STILL STICKS.
------------------	--

Technician Comment	
--------------------	--

C Q I S	
---------	--

Recommendations	
-----------------	--

Tire Information

Tire Manufacturer	Unknown	Tire Size	Unknown
Tire Brand Series		Wheel	
DOT Left Front		DOT Right Front	
DOT Left Rear		DOT Right Rear	
DOT Left Inner		DOT Right Inner	
DOT Spare			

Vehicle Information

VIN	4F2YZ02Z25K	Engine Serial Number	
Model Year	2005	Engine Description	2.3L DOHC EGI I4 16V NA GAS
Transmission	4 SPD AUTO TRANS MAZDA CD4E	Vehicle Description	TRIBUTE
Body Cab Style	CA WE 5 DOOR LIGHT TRUCK	Drive Line	2 WHL L/H FRONT DRIVE
Production Date	30-Nov-2004	Retail Sale Indicator Code	
Plant Description	KANSAS CITY PLANT BUILD	Required Vehicle	
Build Region		Warranty Start Date	30-Dec-2004
Build Country Code		Transmission Serial Number	
Mileage	0	Vehicle Axle Ratio	
Vehicle Restraint Code			

Disclaimer:

This data is for use as one of several potential "awareness" indicators for the Ford Motor Co. Enhanced Concern Identification System. It is unverified, draft, summary data generated from a computer "word search" of customer and technician symptom comments. Supplier data, technician and customer comments are unverified and actual root cause of any potential issue is not established by this summary.

[Contact ODR HELP](#)

Copyright 2001 Ford Motor Co All Rights Reserved

PE12-019

Mazda

9-6-2012

REQUEST NUMBER THREE
DOCUMENTS (SUBJECT)

Consumer Reports

Mazda CAC

ECI

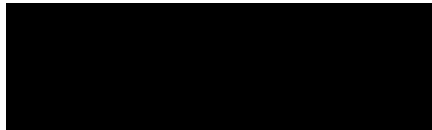



Concern Driven Reporting

Report Detail

Note: Field which are grayed (ghosted) are currently being mapped to the data warehouse. They are not presently being populated.

ECI Record		Source Code	MAZDA eMQF
------------	--	-------------	------------

Commodity Assignment

Commodity	powertrain-engine-accel pedal/linkage/controls	Symptom	engine power-poor performance
Commodity	powertrain-engine-accel pedal/linkage/controls	Symptom	engine power-stall
Commodity	powertrain-engine-accel pedal/linkage/controls	Symptom	function-shuts off
Commodity	powertrain-engine-accel pedal/linkage/controls	Symptom	mod-intermittent/random
Commodity	powertrain-engine-accel pedal/linkage/controls	Symptom	pedal concerns-accelerator pedal
Commodity	powertrain-engine-accel pedal/linkage/controls	Symptom	sticks/binds/grabs
Significant Event		Verified	N

Tread Information

Reported in Tread Quarter	Q3 2008
---------------------------	---------

Report Details

Source Claim Key		Warranty Component Classification (WCC)	
Corporate Product Systems Classification (CPSC)		Time in Service	
Customer Condition Code		V Function Group (VFG)	
Source System Program Type		Repair/Report/Paid Date	10-Sep-2008
Version Series Code	AAAGH	Load Date	22-Oct-2008
Causal Part Prefix- Base - Suffix	- -	Dealer Code	UNKNOW
Causal Part Name	NOT PROVIDED BY SOURCE	Dealer Name	
Non Causal Part Prefix-Base-Suffix		Dealer City	
Non Causal Part Numbers		Dealer State/Province	
Fault Code		Dealer Country	USA
Diagonstic Trouble Code		Dealer Phone Number	
Labor Operation Code		Attachment	
Communication Type		VOQ Component Description Code	
Maintenance Date	22-Oct-2008		

Customer Comment My car as I pull to stop light or a stop sign the engine just shuts off. It's been happening for the last two weeks and I work in sales so unfortunately I haven't been able to take it in yet. The main issue which I just spent \$550 last month or maybe it was two months ago. Sometimes when I would accelerate it would stick, the accelerator would stick and then it would not accelerate. The actual gas pedal would hold tight and it would just accelerate which is very dangerous getting on the freeways when cars were coming. That was my main issue that I spent the money on and that still occurs every once in while as well so now I've got two issues unfortunately.

Technician Comment	
CQIS Recommendations	

Tire Information

Tire Manufacturer	Unknown	Tire Size	Unknown
Tire Brand Series		Wheel	
DOT Left Front		DOT Right Front	
DOT Left Rear		DOT Right Rear	
DOT Left Inner		DOT Right Inner	
DOT Spare			

Vehicle Information

VIN	4F2YZ02Z96K	Engine Serial Number	181005003535
Model Year	2006	Engine Description	2.3L DOHC EGI I4 16V NA GAS
Transmission	4 SPD AUTO TRANS MAZDA CD4E	Vehicle Description	TRIBUTE
Body Cab Style	CA WE 5 DOOR LIGHT TRUCK	Drive Line	2 WHL L/H FRONT DRIVE
Production Date	28-Oct-2005	Retail Sale Indicator Code	
Plant Description	KANSAS CITY PLANT BUILD	Required Vehicle	
Build Region		Warranty Start Date	
Build Country Code		Transmission Serial Number	
Mileage	0	Vehicle Axle Ratio	
Vehicle Restraint Code			

Disclaimer:

This data is for use as one of several potential "awareness" indicators for the Ford Motor Co. Enhanced Concern Identification System. It is unverified, draft, summary data generated from a computer "word search" of customer and technician symptom comments. Supplier data, technician and customer comments are unverified and actual root cause of any potential issue is not established by this summary.

[Contact ODRHELP](#)

Copyright 2001 Ford Motor Co All Rights Reserved

PE12-019

Mazda

9-6-2012

REQUEST NUMBER THREE
DOCUMENTS (SUBJECT)

Consumer Reports

Mazda CAC

ECI

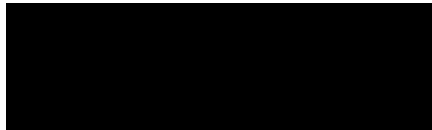



Concern Driven Reporting

Report Detail

Note: Field which are grayed (ghosted) are currently being mapped to the data warehouse. They are not presently being populated.

ECI Record		Source Code	MAZDA eMQF
------------	--	-------------	------------

Commodity Assignment

Commodity	powertrain-engine-accel pedal/linkage/controls	Symptom	mod-driving condition-engine-cold
Commodity	powertrain-engine-accel pedal/linkage/controls	Symptom	mod-driving condition-on acceleration
Commodity	powertrain-engine-accel pedal/linkage/controls	Symptom	mod-driving condition-while driving
Commodity	powertrain-engine-accel pedal/linkage/controls	Symptom	pedal concerns-accelerator pedal
Commodity	powertrain-engine-accel pedal/linkage/controls	Symptom	sticks/binds/grabs
Significant Event		Verified	N

Tread Information

Reported in Tread Quarter	Q4 2008
---------------------------	---------

Report Details

Source Claim Key		Warranty Component Classification (WCC)	
Corporate Product Systems Classification (CPSC)		Time in Service	9
Customer Condition Code		V Function Group (VFG)	
Source System Program Type		Repair/Report/Paid Date	15-Dec-2008
Version Series Code		Load Date	14-Jan-2009
Causal Part Prefix-Base-Suffix	-	Dealer Code	UNKNOW
Causal Part Name	NOT PROVIDED BY SOURCE	Dealer Name	
Non Causal Part Prefix-Base-Suffix		Dealer City	
Non Causal Part Numbers		Dealer State/Province	
Fault Code		Dealer Country	USA
Diagnostic Trouble Code		Dealer Phone Number	
Labor Operation Code		Attachment	
Communication Type		VOQ Component Description Code	
Maintenance Date	14-Jan-2009		

Customer Comment	i think the gas pedal or whatever is behind the gas pedal gets stuck and I have trouble making acceleration smoothUsually the engine is not warmed up.I think I wrote I have 12,000 miles, but I really have 1200 miles.get up and go		
Technician Comment			
C Q I S Recommendations			

Tire Information

Tire Manufacturer	Unknown	Tire Size	Unknown
Tire Brand Series		Wheel	
DOT Left Front		DOT Right Front	
DOT Left Rear		DOT Right Rear	
DOT Left Inner		DOT Right Inner	
DOT Spare			

Vehicle Information

VIN	4F2CZ02Z08K	Engine Serial Number	161107091042
Model Year	2008	Engine Description	2.3L 4V DOHC EFI NA I4 GAS
Transmission	5 SPD MAN TRANS AKK	Vehicle Description	TRIBUTE
Body Cab Style	Unknown	Drive Line	2 WHL L/H FRONT DRIVE
Production Date	17-Jan-2008	Retail Sale Indicator Code	
Plant Description	Unknown	Required Vehicle	
Build Region		Warranty Start Date	22-Mar-2008
Build Country Code		Transmission Serial Number	
Mileage	0	Vehicle Axle Ratio	
Vehicle Restraint Code			

Disclaimer:

This data is for use as one of several potential "awareness" indicators for the Ford Motor Co. Enhanced Concern Identification System. It is unverified, draft, summary data generated from a computer "word search" of customer and technician symptom comments. Supplier data, technician and customer comments are unverified and actual root cause of any potential issue is not established by this summary.

[Contact ODRHELP](#)

Copyright 2001 Ford Motor Co All Rights Reserved

PE12-019

Mazda

9-6-2012

REQUEST NUMBER THREE
DOCUMENTS (SUBJECT)

Consumer Reports

Mazda CAC

ECI

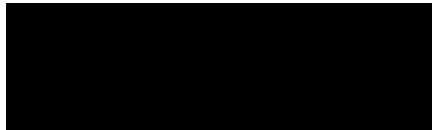



Concern Driven Reporting

Report Detail

Note: Field which are grayed (ghosted) are currently being mapped to the data warehouse. They are not presently being populated.

ECI Record		Source Code	MAZDA Care Surveys
------------	--	-------------	--------------------

Commodity Assignment			
Commodity	powertrain-engine-accel pedal/linkage/controls	Symptom	engine power-loss of power
Commodity	powertrain-engine-accel pedal/linkage/controls	Symptom	function-malfunction/inoperative
Commodity	powertrain-engine-accel pedal/linkage/controls	Symptom	mod-driving condition-at cruise
Commodity	powertrain-engine-accel pedal/linkage/controls	Symptom	mod-driving condition-on acceleration
Commodity	powertrain-engine-accel pedal/linkage/controls	Symptom	mod-driving condition-on deceleration/braking
Commodity	powertrain-engine-accel pedal/linkage/controls	Symptom	mod-driving condition-while driving
Commodity	powertrain-engine-accel pedal/linkage/controls	Symptom	mod-indicator light/warning chime on
Commodity	powertrain-engine-accel pedal/linkage/controls	Symptom	part-missing part
Commodity	powertrain-engine-accel pedal/linkage/controls	Symptom	repair-prior repair mentioned
Commodity	powertrain-engine-air induction-throttle body	Symptom	engine power-loss of power
Commodity	powertrain-engine-air induction-throttle body	Symptom	function-malfunction/inoperative
Commodity	powertrain-engine-air induction-throttle body	Symptom	mod-driving condition-at cruise
Commodity	powertrain-engine-air induction-throttle body	Symptom	mod-driving condition-on acceleration
Commodity	powertrain-engine-air induction-throttle body	Symptom	mod-driving condition-on deceleration/braking
Commodity	powertrain-engine-air induction-throttle body	Symptom	mod-driving condition-while driving
Commodity	powertrain-engine-air induction-throttle body	Symptom	mod-indicator light/warning chime on
Commodity	powertrain-engine-air induction-throttle body	Symptom	part-missing part
Commodity	powertrain-engine-air induction-throttle body	Symptom	repair-prior repair mentioned
Significant Event		Verified	N

Tread Information	
Reported in Tread Quarter	Q3 2010

Report Details			
Source Claim Key		Warranty Component Classification (WCC)	
Corporate Product Systems Classification (CPSC)		Time in Service	48
Customer Condition Code		V Function Group (VFG)	
Source System Program Type		Repair/Report/Paid Date	28-Jul-2010
Version Series Code	AAAGH	Load Date	12 -Aug-2010
Causal Part Prefix- Base - Suffix	-	Dealer Code	10173
Causal Part Name	NOT PROVIDED BY SOURCE	Dealer Name	AUBURN VALLEY MAZDA
Non Causal Part Prefix-Base-Suffix		Dealer City	AUBURN
Non Causal Part Numbers		Dealer State/Province	WA
Fault Code		Dealer Country	USA
Diagnostic Trouble Code		Dealer Phone Number	
Labor Operation Code		Attachment	
Communication Type		VOQ Component Description Code	
Maintenance Date	12 -Aug-2010		

Customer Comment	Took car in to be diagnosed since car felt like it was still accelerating when braking. Technician diagnosed problem and decided to replace the throttle body. Had to bring car back since part was not in stock. Left car at dealership all day. Picked up car and check engine light was on. There was nobody available to look at error and I was told to bring car back the next day. On the way home the car almost broke down 3 times and was losing power. I was scared of breaking down in the middle of the road and getting hit. When I returned the next day they found out that the technician did not properly install connection. Shop promised to test drive car good after fixing problem. Noting mileage at drop off and pick up and they only test drove 2 miles leaving me unconfident that the problem was fixed. In between bringing the car in my cruise control stopped working. I called to try and make another appointment since I was afraid of going over 50K mile warranty over holiday weeken
Technician Comment	
CQIS Recommendations	

Tire Information			
Tire Manufacturer	Unknown	Tire Size	Unknown
Tire Brand Series		Wheel	
DOT Left Front		DOT Right Front	
DOT Left Rear		DOT Right Rear	
DOT Left Inner		DOT Right Inner	
DOT Spare			

Vehicle Information			
VIN	4F2YZ02Z96K	Engine Serial Number	141205134748
Model Year	2006	Engine Description	2.3L DOHC EGI I4 16V NA GAS
Transmission	4 SPD AUTO TRANS MAZDA CD4E	Vehicle Description	TRIBUTE
Body Cab Style	CA WE 5 DOOR LIGHT TRUCK	Drive Line	2 WHL L/H FRONT DRIVE
Production Date	18-Jan-2006	Retail Sale Indicator Code	
Plant Description	KANSAS CITY PLANT BUILD	Required Vehicle	
Build Region		Warranty Start Date	06-Sep-2006
Build Country Code		Transmission Serial Number	

Mileage	0	Vehicle Axle Ratio	
Vehicle Restraint Code			

Disclaimer:

This data is for use as one of several potential "awareness" indicators for the Ford Motor Co. Enhanced Concern Identification System. It is unverified, draft, summary data generated from a computer "word search" of customer and technician symptom comments. Supplier data, technician and customer comments are unverified and actual root cause of any potential issue is not established by this summary.

[Contact CDR HELP](#)

Copyright 2001 Ford Motor Co. All Rights Reserved

PE12-019

Mazda

9-6-2012

REQUEST NUMBER THREE
DOCUMENTS (SUBJECT)

Consumer Reports

Mazda CAC

ECI

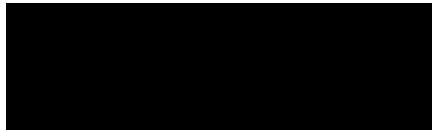



Concern Driven Reporting

Report Detail

Note: Field which are grayed (ghosted) are currently being mapped to the data warehouse. They are not presently being populated.

ECI Record		Source Code	MAZDA Care Surveys
------------	--	-------------	--------------------

Commodity Assignment

Commodity	powertrain-engine-accel pedal/linkage/controls	Symptom	function-malfunction/inoperative
Commodity	powertrain-engine-accel pedal/linkage/controls	Symptom	pedal concerns-accelerator pedal
Commodity	powertrain-engine-accel pedal/linkage/controls	Symptom	repair-prior repair mentioned
Commodity	powertrain-engine-accel pedal/linkage/controls	Symptom	sticks/binds/grabs
Commodity	powertrain-engine-accessory drive-pulley/tension	Symptom	function-malfunction/inoperative
Commodity	powertrain-engine-accessory drive-pulley/tension	Symptom	repair-prior repair mentioned
Commodity	powertrain-engine-accessory drive-pulley/tension	Symptom	sticks/binds/grabs
Significant Event		Verified	N

Tread Information

Reported in Tread Quarter Q3 2011

Report Details

Source Claim Key		Warranty Component Classification (WCC)	
Corporate Product Systems Classification (CPSC)		Time in Service	42
Customer Condition Code		V Function Group (VFG)	
Source System Program Type		Repair/Report/Paid Date	22-Sep-2011
Version Series Code		Load Date	11-Oct-2011
Causal Part Prefix-Base-Suffix	-	Dealer Code	50514
Causal Part Name	NOT PROVIDED BY SOURCE	Dealer Name	DUNCAN MAZDA
Non Causal Part Prefix-Base-Suffix		Dealer City	BLACKSBURG
Non Causal Part Numbers		Dealer State/Province	VA
Fault Code		Dealer Country	USA
Diagnostic Trouble Code		Dealer Phone Number	
Labor Operation Code		Attachment	
Communication Type		VOQ Component Description Code	
Maintenance Date	12-Oct-2011		

Customer Comment The vehicle's throttle continues to stick in a closed position and has to be stomped on to get the vehicle to move. This was at least the third time vehicle was brought in for same problem. The other problem which was a belt pulley of some sort was replaced satisfactorily although, with the age of the belt, it should have been suggested to us to have it replaced while they had the vehicle apart.

Technician Comment
CQIS Recommendations

Tire Information

Tire Manufacturer	Unknown	Tire Size	P235/70R 16T BSW A S
Tire Brand Series		Wheel	
DOT Left Front		DOT Right Front	
DOT Left Rear		DOT Right Rear	
DOT Left Inner		DOT Right Inner	
DOT Spare			

Vehicle Information

VIN	4F2CZ02Z08K	Engine Serial Number	181007230541
Model Year	2008	Engine Description	2.3L 4V DOHC EFI NA I4 GAS
Transmission	4 SPD AUTO TRANS NAAO CD4E	Vehicle Description	TRIBUTE
Body Cab Style	Unknown	Drive Line	2 WHL L/H FRONT DRIVE
Production Date	25-Oct-2007	Retail Sale Indicator Code	
Plant Description	KANSAS CITY PLANT BUILD	Required Vehicle	
Build Region		Warranty Start Date	26-Apr-2008
Build Country Code		Transmission Serial Number	100772920322
Mileage	0	Vehicle Axle Ratio	
Vehicle Restraint Code			

Disclaimer:

This data is for use as one of several potential "awareness" indicators for the Ford Motor Co. Enhanced Concern Identification System. It is unverified, draft, summary data generated from a computer "word search" of customer and technician symptom comments. Supplier data, technician and customer comments are unverified and actual root cause of any potential issue is not established by this summary.

[Contact ODRHELP](#)

Copyright 2001 Ford Motor Co All Rights Reserved

PE12-019

Mazda

9-6-2012

REQUEST NUMBER THREE
DOCUMENTS (SUBJECT)

Consumer Reports

Mazda CAC

ECI

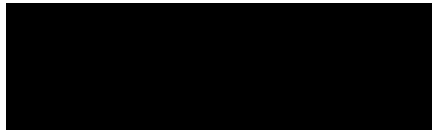



Concern Driven Reporting

Report Detail

Note: Field which are grayed (ghosted) are currently being mapped to the data warehouse. They are not presently being populated.

ECI Record		Source Code	MAZDA Care Surveys
------------	--	-------------	--------------------

Commodity Assignment			
Commodity	powertrain-engine-accel pedal/linkage/controls	Symptom	damage
Commodity	powertrain-engine-accel pedal/linkage/controls	Symptom	frozen/seized
Commodity	powertrain-engine-accel pedal/linkage/controls	Symptom	mod-child related
Commodity	powertrain-engine-accel pedal/linkage/controls	Symptom	pedal concerns-accelerator pedal
Commodity	powertrain-engine-air induction-throttle body-	Symptom	damage
Commodity	powertrain-engine-air induction-throttle body-	Symptom	frozen/seized
Commodity	powertrain-engine-air induction-throttle body-	Symptom	mod-child related
Significant Event		Verified	N

Tread Information	
Reported in Tread Quarter	Q4 2011

Report Details			
Source Claim Key		Warranty Component Classification (WCC)	
Corporate Product Systems Classification (CPSC)		Time in Service	69
Customer Condition Code		V Function Group (VFG)	
Source System Program Type		Repair/Report/Paid Date	15-Nov-2011
Version Series Code	AAAGH	Load Date	11-Dec-2011
Causal Part Prefix-Base-Suffix	-	Dealer Code	34469
Causal Part Name	NOT PROVIDED BY SOURCE	Dealer Name	BOMMARITO MAZDA
Non Causal Part Prefix-Base-Suffix		Dealer City	SAINT PETERS
Non Causal Part Numbers		Dealer State/Province	MO
Fault Code		Dealer Country	USA
Diagnostic Trouble Code		Dealer Phone Number	6369282300
Labor Operation Code		Attachment	
Communication Type		VOQ Component Description Code	
Maintenance Date	11-Dec-2011		

Customer Comment	Sent out emails to tribute owners when they learned that the injector system would damage the throttle body where it would have to be totally replaced, as ours was. Looked in service manual, never saw any indication that this expensive, injector cleaning process was even required. We were rather blind sided and had to pay about \$500 to fix it.....not to mention the danger we were put in when our exceleator pedal froze up in heavy traffic wour grandson in the car.		
Technician Comment			
CQIS Recommendations			

Tire Information			
Tire Manufacturer	Unknown	Tire Size	Unknown
Tire Brand Series		Wheel	
DOT Left Front		DOT Right Front	
DOT Left Rear		DOT Right Rear	
DOT Left Inner		DOT Right Inner	
DOT Spare			

Vehicle Information			
VIN	4F2YZ02Z66K	Engine Serial Number	151205220658
Model Year	2006	Engine Description	2.3L DOHC EGI I4 16V NA GAS
Transmission	4 SPD AUTO TRANS MAZDA CD4E	Vehicle Description	TRIBUTE
Body Cab Style	CA WE 5 DOOR LIGHT TRUCK	Drive Line	2 WHL L/H FRONT DRIVE
Production Date	23-Jan-2006	Retail Sale Indicator Code	
Plant Description	KANSAS CITY PLANT BUILD	Reaquired Vehicle	
Build Region		Warranty Start Date	10-Apr-2006
Build Country Code		Transmission Serial Number	
Mileage	0	Vehicle Axle Ratio	
Vehicle Restraint Code			

Disclaimer:

This data is for use as one of several potential "awareness" indicators for the Ford Motor Co. Enhanced Concern Identification System. It is unverified, draft, summary data generated from a computer "word search" of customer and technician symptom comments. Supplier data, technician and customer comments are unverified and actual root cause of any potential issue is not established by this summary.

[Contact ODRHELP](#)

Copyright 2001 Ford Motor Co All Rights Reserved

PE12-019

Mazda

9-6-2012

REQUEST NUMBER THREE
DOCUMENTS (SUBJECT)

Consumer Reports

Mazda CAC

ECI

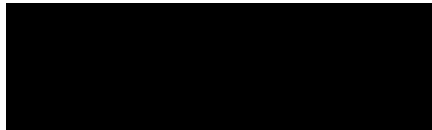



Concern Driven Reporting

Report Detail

Note: Field which are grayed (ghosted) are currently being mapped to the data warehouse. They are not presently being populated.

ECI Record		Source Code	MAZDA KANA
------------	--	-------------	------------

Commodity Assignment

Commodity	powertrain-engine-accel pedal/linkage/controls	Symptom	engine power-misfire/runs rough
Commodity	powertrain-engine-accel pedal/linkage/controls	Symptom	field service action
Commodity	powertrain-engine-accel pedal/linkage/controls	Symptom	function-malfunction/inoperative
Commodity	powertrain-engine-accel pedal/linkage/controls	Symptom	function-shuts off
Commodity	powertrain-engine-accel pedal/linkage/controls	Symptom	mod-driving condition-at start up
Commodity	powertrain-engine-accel pedal/linkage/controls	Symptom	mod-driving condition-in park
Commodity	powertrain-engine-accel pedal/linkage/controls	Symptom	mod-intermittent/random
Commodity	powertrain-engine-accel pedal/linkage/controls	Symptom	pedal concerns-accelerator pedal
Commodity	powertrain-engine-accel pedal/linkage/controls	Symptom	sticks/binds/grabs
Commodity	powertrain-engine-electronic engine control	Symptom	engine power-misfire/runs rough
Commodity	powertrain-engine-electronic engine control	Symptom	field service action
Commodity	powertrain-engine-electronic engine control	Symptom	function-malfunction/inoperative
Commodity	powertrain-engine-electronic engine control	Symptom	function-shuts off
Commodity	powertrain-engine-electronic engine control	Symptom	mod-driving condition-at start up
Commodity	powertrain-engine-electronic engine control	Symptom	mod-driving condition-in park
Commodity	powertrain-engine-electronic engine control	Symptom	mod-intermittent/random
Commodity	powertrain-engine-electronic engine control	Symptom	sticks/binds/grabs
Significant Event		Verified	N

Tread Information

Reported in Tread Quarter	Q4 2004
---------------------------	---------

Report Details

Source Claim Key		Warranty Component Classification (WCC)	
Corporate Product Systems Classification (CPSC)		Time in Service	
Customer Condition Code	B	V Function Group (VFG)	
Source System Program Type		Repair/Report/Paid Date	22-Nov-2004
Version Series Code	UNKN	Load Date	28-Nov-2004
Causal Part Prefix- Base - Suffix	- -	Dealer Code	
Causal Part Name	NOT PROVIDED BY SOURCE	Dealer Name	NOT PROVIDED BY SOURCE
Non Causal Part Prefix-Base-Suffix		Dealer City	
Non Causal Part Numbers		Dealer State/Province	
Fault Code		Dealer Country	USA
Diagonstic Trouble Code		Dealer Phone Number	
Labor Operation Code		Attachment	
Communication Type		VOQ Component Description Code	
Maintenance Date	28-Nov-2004		

Customer Comment My wife and I bought a new Mazda Tribute 2001 from Dean Patterson 101 Pleasant Valley Blv. Altoona Pa 16602. My wife and I both liked the car very much, however it has been nothing but problems, first transmission went out, front end ball jountins gas peddle stuck, and then a recall on seat belts and more important a recall on something to do with the computer, ever since then the car started running like crap, when you first start it it wants to and does sometimes shut off, if you step on the gas when it is in park it spits and sputters, put it in drive and it runs fine. My warranty ran out

Technician Comment
CQIS Recommendations

Tire Information

Tire Manufacturer	Unknown	Tire Size	Unknown
Tire Brand Series		Wheel	
DOT Left Front		DOT Right Front	
DOT Left Rear		DOT Right Rear	
DOT Left Inner		DOT Right Inner	
DOT Spare			

Vehicle Information

VIN	UNK TRIBUTE	Engine Serial Number	UNKNOWN
Model Year	2001	Engne Description	Unknown
Transmission	Unknown	Vehicle Description	TRIBUTE
Body Cab Style	UNKN Unknown	Drive Line	Unknown
Production Date		Retail Sale Indicator Code	
Plant Description	Unknown	Reaquired Vehicle	
Build Region		Warranty Start Date	
Build Country Code		Transmission Serial Number	UNKNOWN
Mileage	0	Vehicle Axle Ratio	
Vehicle Restraint Code			

Disclaimer:

This data is for use as one of several potential "awareness" indicators for the Ford Motor Co. Enhanced Concern Identification System. It is unverified, draft, summary data generated from a computer "word search" of customer and technician symptom comments. Supplier data, technician and customer comments are unverified and actual root cause of any potential issue is not established by this summary.

[Contact ODRHELP](#)

Copyright 2001 Ford Motor Co All Rights Reserved

PE12-019

Mazda

9-6-2012

REQUEST NUMBER THREE
DOCUMENTS (SUBJECT)

Consumer Reports

Mazda CAC

ECI

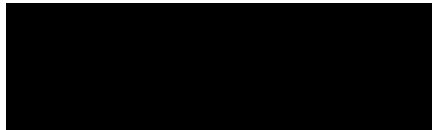



Concern Driven Reporting

Report Detail

Note: Field which are grayed (ghosted) are currently being mapped to the data warehouse. They are not presently being populated.

ECI Record		Source Code	MAZDA KANA
------------	--	-------------	------------

Commodity Assignment

Commodity	powertrain-engine-accel pedal/linkage/controls	Symptom	field service action
Commodity	powertrain-engine-accel pedal/linkage/controls	Symptom	high effort
Commodity	powertrain-engine-accel pedal/linkage/controls	Symptom	mod-weather-cold
Commodity	powertrain-engine-accel pedal/linkage/controls	Symptom	pedal concerns-accelerator pedal
Commodity	powertrain-engine-accel pedal/linkage/controls	Symptom	sticks/binds/grabs
Significant Event		Verified	N

Tread Information

Reported in Tread Quarter	Q4 2004
---------------------------	---------

Report Details

Source Claim Key		Warranty Component Classification (WCC)	
Corporate Product Systems Classification (CPSC)		Time in Service	36
Customer Condition Code	B	V Function Group (VFG)	
Source System Program Type		Repair/Report/Paid Date	15-Dec-2004
Version Series Code	AAAA5	Load Date	19-Dec-2004
Causal Part Prefix-Base-Suffix	-	Dealer Code	
Causal Part Name	NOT PROVIDED BY SOURCE	Dealer Name	NOT PROVIDED BY SOURCE
Non Causal Part Prefix-Base-Suffix		Dealer City	
Non Causal Part Numbers		Dealer State/Province	
Fault Code		Dealer Country	USA
Diagnostic Trouble Code		Dealer Phone Number	
Labor Operation Code		Attachment	
Communication Type		VOQ Component Description Code	
Maintenance Date	19-Dec-2004		

Customer Comment	Ford just announced a recall on Escapes with an accelerator cable problem. Since the Tribute has a Ford engine, will there be a similar recall with my vehicle I am having problems in cold weather where my accelerator pedal is hard to press at first; it's either binding or something like that. I only have 32,000 mi and this problem was not there when it was new but appeared a year or so ago and is getting worse. Just wondering if the Escape recall will apply here and fix my problem. Thanks
Technician Comment	
CQIS Recommendations	

Tire Information

Tire Manufacturer	Unknown	Tire Size	Unknown
Tire Brand Series		Wheel	
DOT Left Front		DOT Right Front	
DOT Left Rear		DOT Right Rear	
DOT Left Inner		DOT Right Inner	
DOT Spare			

Vehicle Information

VIN	4F2CU08192K	Engine Serial Number	092429087
Model Year	2002	Engine Description	3.0L DOHC EGI V6 NA*GAS
Transmission	4 SPD AUTO TRANS MAZDA CD4E	Vehicle Description	TRIBUTE
Body Cab Style	CA WE 5 DOOR LIGHT TRUCK	Drive Line	4 WHL L/H PART TIME DRIVE
Production Date	03-Oct-2001	Retail Sale Indicator Code	
Plant Description	KANSAS CITY PLANT BUILD	Required Vehicle	
Build Region		Warranty Start Date	11-Jan-2002
Build Country Code		Transmission Serial Number	
Mileage	0	Vehicle Axle Ratio	
Vehicle Restraint Code			

Disclaimer:

This data is for use as one of several potential "awareness" indicators for the Ford Motor Co. Enhanced Concern Identification System. It is unverified, draft, summary data generated from a computer "word search" of customer and technician symptom comments. Supplier data, technician and customer comments are unverified and actual root cause of any potential issue is not established by this summary.

[Contact ODRHELP](#)

Copyright 2001 Ford Motor Co All Rights Reserved

PE12-019

Mazda

9-6-2012

REQUEST NUMBER THREE
DOCUMENTS (SUBJECT)

Consumer Reports

Mazda CAC

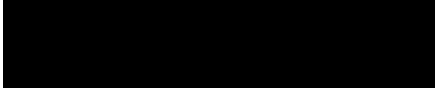
ECI _CAC record

Logout Tools Help Welcome Paul Winovitch EPIPHANY

Home Requests Vehicle Summary Vehicle Summary Request - Recall Inquiry Request - veh jumps forward Request - Recall Inquiry Vehicle Summary Vehicle Summary Vehicle Summary Request

Request Save New Refresh Escalate Create New Task Actions History

Inquiry on recall

Account/Interaction Summary

<p>██████████</p> <p>██████████</p> <p>CINCINNATI OH ██████████</p> <p>Phone number unknown</p> <p>E-mail address unknown</p>	<p>Current Vehicles(1)</p> <p>Requests(1)</p> <p>Open Requests(0)</p> <p>Pending Dealer Requests(0)</p>
---	---

ID: ██████████ Created: 8/23/05 6:25 AM by: Karen Oeffinger Updated: 8/23/05 6:26 AM by: Karen Oeffinger

Assigned Agent: ██████████ Create Date: 8/23/05 Status: Closed Date Closed: 8/23/05 6:26 AM Satisfaction Code: Satisfied Escalated:

Customer: ██████████ Assigned Region: Midwest Region Source: Special Campaign

Description: Inquiry on recall Responsible Dealer: Resolving Dealer: Add'l Requests: No Goodwill: No Hotline: No Branded: No Campaign: Yes Log #:
 Notes: Customer states he saw on the internet that his veh had a recall and wanted to know what he needs to do

Reason 1: RECALL/BSP (5) Reason 2:
 Category:
 Comment:
 Primary Contact Code: Type: INQUIRY (3) Component:
 VIN: 4F2Y204143 Mileage: Model: TRB TRIBUTE Year: 2003 Transmission: Automatic Previous Repair Attempt:
 Agent Notes Contact Codes Goodwill Requests CRV CC Case Detail Attachments Tasks Knowledge Documents Emails Audit Trails Send To Dealer History

Agent Notes 1-1 of 1

Created Date	Created By	Type	Text	Delete
8/23/05 6:26 AM	Karen Oeffinger	Agent Closing Request Note	provided cust with recall info and adv to make appt at dir thanked	<input type="button" value="X"/>

Notepad

PE12-019

Mazda

9-6-2012

REQUEST NUMBER THREE
DOCUMENTS (SUBJECT)

Consumer Reports

Mazda CAC

ECI

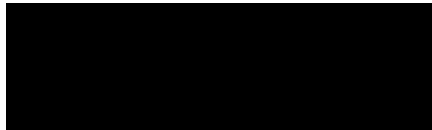



Concern Driven Reporting

Report Detail

Note: Field which are grayed (ghosted) are currently being mapped to the data warehouse. They are not presently being populated.

ECI Record		Source Code	MAZDA KANA
------------	--	-------------	------------

Commodity Assignment			
Commodity	powertrain-engine-accel pedal/linkage/controls	Symptom	engine rpm surge/flare
Commodity	powertrain-engine-accel pedal/linkage/controls	Symptom	field service action
Commodity	powertrain-engine-accel pedal/linkage/controls	Symptom	mod-driving condition-on acceleration
Commodity	powertrain-engine-accel pedal/linkage/controls	Symptom	mod-driving condition-while driving
Commodity	powertrain-engine-accel pedal/linkage/controls	Symptom	mod-weather-cold
Commodity	powertrain-engine-accel pedal/linkage/controls	Symptom	mod-weather-hot
Commodity	powertrain-engine-accel pedal/linkage/controls	Symptom	no problem found
Commodity	powertrain-engine-accel pedal/linkage/controls	Symptom	pedal concerns-accelerator pedal
Commodity	powertrain-engine-accel pedal/linkage/controls	Symptom	sticks/binds/grabs
Significant Event		Verified	N

Tread Information	
Reported in Tread Quarter	Q4 2005

Report Details			
Source Claim Key		Warranty Component Classification (WCC)	
Corporate Product Systems Classification (CPSC)		Time in Service	33
Customer Condition Code	B	V Function Group (VFG)	
Source System Program Type		Repair/Report/Paid Date	13-Oct-2005
Version Series Code	AAAA5	Load Date	16-Oct-2005
Causal Part Prefix- Base - Suffix	- -	Dealer Code	
Causal Part Name	NOT PROVIDED BY SOURCE	Dealer Name	NOT PROVIDED BY SOURCE
Non Causal Part Prefix-Base-Suffix		Dealer City	
Non Causal Part Numbers		Dealer State/Province	
Fault Code		Dealer Country	USA
Diagonstic Trouble Code		Dealer Phone Number	
Labor Operation Code		Attachment	
Communication Type		VOQ Component Description Code	
Maintenance Date	16-Oct-2005		

Customer Comment	The gas pedal on this vehicle is once again sticking. Corrected in 2003 at no cost. The problem occurs when you accelerate from a complete stop, the gas pedal sticks before releasing causing the engine to race. Not a big problem during the summer when you are aware of the problem but can be very dangerous once winter weather returns. Had hoped the problem would be fixed with a recall done on this vehicle about a month ago but that was not the case. Told by dealership this is a routine problem, something (not sure what it was) has to be cleaned very 30,000 miles or so at a cost to fix of
Technician Comment	
CQIS Recommendations	

Tire Information			
Tire Manufacturer	Unknown	Tire Size	Unknown
Tire Brand Series		Wheel	
DOT Left Front		DOT Right Front	
DOT Left Rear		DOT Right Rear	
DOT Left Inner		DOT Right Inner	
DOT Spare			

Vehicle Information			
VIN	4F2YZ04143K	Engine Serial Number	
Model Year	2003	Engine Description	3.0L DOHC EGI V6 NA*G DSP2967
Transmission	4 SPD AUTO TRANS MAZDA CD4E	Vehicle Description	TRIBUTE
Body Cab Style	CA WE 5 DOOR LIGHT TRUCK	Drive Line	2 WHL L/H FRONT DRIVE
Production Date	03-Dec-2002	Retail Sale Indicator Code	
Plant Description	KANSAS CITY PLANT BUILD	Required Vehicle	
Build Region		Warranty Start Date	24-Feb-2003
Build Country Code		Transmission Serial Number	
Mileage	0	Vehicle Axle Ratio	
Vehicle Restraint Code			

Disclaimer:

This data is for use as one of several potential "awareness" indicators for the Ford Motor Co. Enhanced Concern Identification System. It is unverified, draft, summary data generated from a computer "word search" of customer and technician symptom comments. Supplier data, technician and customer comments are unverified and actual root cause of any potential issue is not established by this summary.

[Contact ODRHELP](#)

Copyright 2001 Ford Motor Co All Rights Reserved

PE12-019

Mazda

9-6-2012

REQUEST NUMBER THREE
DOCUMENTS (SUBJECT)

Consumer Reports

Mazda CAC

ECI _CAC record

Logout Tools Help Welcome Paul Winovitch EPIPHANY

Home Requests Vehicle Summary Vehicle Summary Request - Recall Inquiry Request - veh jumps forward Request - Recall Inquiry Vehicle Summary Vehicle Summary Vehicle Summary Request

Request Save New Refresh Escalate Create New Task Actions History

Stalling cond

Account/Interaction Summary

PHILADELPHIA PA Phone number unknown E-mail address unknown	Current Vehicles(2) Requests(1) Open Requests(0) Pending Dealer Requests(0)
---	--

ID: 109007780 Created: 8/18/06 2:47 PM by: Jerry Sanchez Updated: 2/16/07 7:38 AM by: William Zdan

Assigned Agent: <input type="text" value="Item Is Closed"/>	Create Date: 8/18/06	Status: Closed	Date Closed: 2/16/07 7:38 AM	Satisfaction Code: Satisfied	Escalated: <input type="checkbox"/>
---	----------------------	----------------	------------------------------	------------------------------	-------------------------------------

Customer: <input type="text" value=""/>	Assigned Region: Northeast Region	Source: Customer Mediation/Legal
---	-----------------------------------	----------------------------------

Description: Stalling cond	Responsible Dealer: 50359	Responsible Dealer Name: PACIFICO MAZDA	Responsible Dealer Phone: 215-3657400
Notes: 8-18-06 - Received Regional Assist Request from Bob FOM.	Resolving Dealer: 50359	Resolving Dealer Name: PACIFICO MAZDA	Resolving Dealer Phone: 215-3657400

Add'l Requests: No	Hotline: Yes	Campaign: No
Goodwill: No	Branded: No	Log #: 008863

Primary Contact Code

Type: PRODUCT RELATED COMPLAINT (1)	Reason 1: PRODUCT (1)	Reason 2: LEMON/LLEGAL (1)
Component: ENGINE	Category: PISTON ENGINE (b)	Comment: STALLS/WILL RESTART (05)

VIN: 4F2YZ02Z76K	Mileage: 4,000	Model: TRB TRIBUTE	Year: 2006	Transmission: Automatic	Previous Repair Attempt: -----
------------------	----------------	--------------------	------------	-------------------------	--------------------------------

Agent Notes Contact Codes Goodwill Requests CRV CC Case Detail Attachments Tasks Knowledge Documents Emails Audit Trails Send To Dealer History

CRV Detail

CRV Base Information:			Resale Details:			Financials:		
Log Number: 008863	CRV Type: LEMON LAW	Reason CRV: VOLUNTARY	KBB Price:	kbb Price Date: 9/12/06	Condition:	Repurchase Amount: 17,880	Voluntary Trade Assist Amt:	
CRV Status: Sold	Repurchase: Yes	Tradeout: Yes	Committed To:	Hold Until:	Attorney Fee/Legal/Misc:	Total Repurch Amt: \$17880.0		
	Yes	Yes	Sold To:	Resale State:	Mileage:	Resale Amount:		
	No	No						

Notepad

* Buyback vehicle

PE12-019

Mazda

9-6-2012

REQUEST NUMBER THREE
DOCUMENTS (SUBJECT)

Consumer Reports

Mazda CAC

ECI

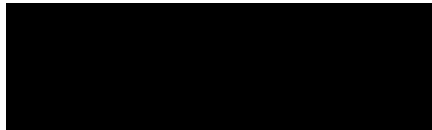



Concern Driven Reporting

Report Detail

Note: Field which are grayed (ghosted) are currently being mapped to the data warehouse. They are not presently being populated.

ECI Record		Source Code	MAZDA KANA
------------	--	-------------	------------

Commodity Assignment			
Commodity	powertrain-engine-accel pedal/linkage/controls	Symptom	engine power-stall
Commodity	powertrain-engine-accel pedal/linkage/controls	Symptom	function-malfunction/inoperative
Commodity	powertrain-engine-accel pedal/linkage/controls	Symptom	function-shuts off
Commodity	powertrain-engine-accel pedal/linkage/controls	Symptom	mod-driving condition-when engine/ignition turned off
Commodity	powertrain-engine-accel pedal/linkage/controls	Symptom	pedal concerns-accelerator pedal
Significant Event		Verified	N

Tread Information	
Reported in Tread Quarter	Q3 2006

Report Details			
Source Claim Key		Warranty Component Classification (WCC)	
Corporate Product Systems Classification (CPS)		Time in Service	0
Customer Condition Code	B	V Function Group (VFG)	
Source System Program Type		Repair/Report/Paid Date	24-Jul-2006
Version Series Code	AAAGH	Load Date	30-Jul-2006
Causal Part Prefix-Base-Suffix	-	Dealer Code	
Causal Part Name	NOT PROVIDED BY SOURCE	Dealer Name	NOT PROVIDED BY SOURCE
Non Causal Part Prefix-Base-Suffix		Dealer City	
Non Causal Part Numbers		Dealer State/Province	
Fault Code		Dealer Country	USA
Diagnostic Trouble Code		Dealer Phone Number	
Labor Operation Code		Attachment	
Communication Type		VOQ Component Description Code	
Maintenance Date	30-Jul-2006		

Customer Comment	IVE BEEN HAVING PROBLEMS WITH MY TRIBUTE IT SHUTS OFF ON ME AND I ACTUALLY HAVE TO REALLY PUSH ON THE GAS PEDAL FOR THE CAR TO MOVE, IT DOESNT SHIFT GEARS RIGHT. ON JULY 20, 2006 I TOOK IT BACK TO PACIFICO MAZDA ON ESSINGTON AVENUE IN SOUTHWEST PHILA. AND THEY TOLD ME THERE IS NOTHING WRONG WITH THE CAR AND IM NOT COMPLETELY SATISFIED WITH THAT ANSWER I GOT THE CAR BACK THURSDAY NIGHT. AGAIN ON FRIDAY IM BACKING INTO A PARKING SPOT HALFWAY INTO THE SPOT THE CAR SHUT OFF ON ME. SO NOW I HAVE TO TAKE THE CAR BACK ONCE AGAIN. I CALLED AND SPOKE TO THE SERVICE MGR. HE TOLD ME THAT HIS MECHANIC S		
Technician Comment			
CQIS Recommendations			

Tire Information			
Tire Manufacturer	Unknown	Tire Size	Unknown
Tire Brand Series		Wheel	
DOT Left Front		DOT Right Front	
DOT Left Rear		DOT Right Rear	
DOT Left Inner		DOT Right Inner	
DOT Spare			

Vehicle Information			
VIN	4F2YZ02Z76K	Engine Serial Number	
Model Year	2006	Engine Description	2.3L DOHC EGI I4 16V NA GAS
Transmission	4 SPD AUTO TRANS MAZDA CD4E	Vehicle Description	TRIBUTE
Body Cab Style	CA WE 5 DOOR LIGHT TRUCK	Drive Line	2 WHL L/H FRONT DRIVE
Production Date	05-Jan-2006	Retail Sale Indicator Code	
Plant Description	KANSAS CITY PLANT BUILD	Required Vehicle	
Build Region		Warranty Start Date	10-Mar-2006
Build Country Code		Transmission Serial Number	
Mileage	0	Vehicle Axle Ratio	
Vehicle Restraint Code			

Disclaimer:

This data is for use as one of several potential "awareness" indicators for the Ford Motor Co. Enhanced Concern Identification System. It is unverified, draft, summary data generated from a computer "word search" of customer and technician symptom comments. Supplier data, technician and customer comments are unverified and actual root cause of any potential issue is not established by this summary.

[Contact ODRHELP](#)

Copyright 2001 Ford Motor Co All Rights Reserved

PE12-019

Mazda

9-6-2012

REQUEST NUMBER THREE
DOCUMENTS (SUBJECT)

Consumer Reports

Mazda CAC

ECI

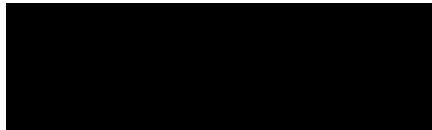

Tread Information	
Reported in Tread Quarter	Q4 2005

Report Details			
Source Claim Key		Warranty Component Classification (WCC)	
Corporate Product Systems Classification (CPSC)		Time in Service	
Customer Condition Code		V Function Group (VFG)	
Source System Program Type		Repair/Report/Paid Date	28-Nov-2005
Version Series Code	AAAAX	Load Date	14-Dec-2005
Causal Part Prefix- Base - Suffix	-	Dealer Code	
Causal Part Name	NOT PROVIDED BY SOURCE	Dealer Name	NOT PROVIDED BY SOURCE
Non Causal Part Prefix-Base-Suffix		Dealer City	
Non Causal Part Numbers		Dealer State/Province	
Fault Code		Dealer Country	USA
Diagonstic Trouble Code		Dealer Phone Number	
Labor Operation Code		Attachment	
Communication Type		VOQ Component Description Code	
Maintenance Date	29-Mar-2006		

Customer Comment	
Technician Comment	Complaint AP 11/2 2 51 BOOSTER.LEFT EXHM GSKTS.MOUNT. Comment REAR LOWER ENGM(4) Notes C; HISSING NOISE FROM BRAKES. C; BOOSTER LEAKING EXTERNALLY. MATERIAL FAILURE. C; REPLACE. C; TICKING NOISE. C; EXH MNFLD GASKETS LEAKING EXTERNALLY. MATERIAL FAILURE. C; REPLACE. C; NOISE IN STEERING. C; RACK HAS EXCESSIVE PLAY AND NOISE. MATERIAL FAILURE. C; REPLACE. C; TECH FOUND. C; MOTOR MOUNT HAS PLAY AND NOISE. MATERIAL FAILURE. C; REPLACE. NO OTHER COMPLAINTS. WILL CB WITH COMPLETE ESTIMATE. W ID(LARRY WRIGHT) CALLING W SAYS CLAIM WAS SUPPOSED TO BE SET UP FOR INSPECTION YESTERDAY BUT INSPECTOR HAS NOT BEEN OUT. ADV HIM NOT SO. ADV HIM WAITING ON COMPLETE EST. SAYS HAS ESTIMATE. TOOK ESTIMATE ADV HIM WOULD INSPECT APOLOGIZED FOR MISCOMMUNICATION CAR WILL BE AT SHOP AND TECH CAN SHOW FAILURES W INSPECT RECD EM FROM CARR STATES INSPECTOR RAN OUT OF TIME YESTERDAY. HAS SET INSPECTION UP WITH SHOP FOR TODAY @ 1 30 EST INSPECTION 1)GEORGE PEDREGON CARR DIGITAL PICS #9154970179 2)M 50142 V M57522 CH SAMUEL PEREZ 3)3.0 AUTO 4)C VEHICLE HAS AIR ESCAPING HISSING TYPE COMING FROM BRAKE/GAS AREA C VEHICLE HAS A TICKING NOISE ON COLD STARTS MAYBE EXHAUST LEAK C VEHICLE HAS A GRINDING/VIBRATION IN THE STRG COLUMN 5)FINDINGS TD NONE BRAKE BOOSTER LEAKING VACUUM FROM THE DIAGPHAM & BRAKE PEDAL HARDER THEN NORMAL TICKING NOISE COMING FROM THE LEFT SIDE OF THE ENGINE LEFT EXHAUST MANIFOLD GS LEAKING LEAKING, NO WARPAGE TO THE MANIFOLD LEFT LOWER ENGINE MOUNT HAS COLLSPED & LEAKING OIL OIL ON THE RACK IS FROM THE ENGINE MOUNT STRG RACK FLUID FULL NO VIBRATION FROM THE STRG WHEEL STRG RACK BOOTS ARE CLEAN NO FAILURE TO THE STRG RACK 6)COF INTERNAL FAILURE BRAKE BOOSTER DIAGPHAM LEAKING VACUUM FAILURE LEFT LOWER ENGINE MOUNT COLLSPED & LEAKING OIL FAILURE LEFT EXHAUST MANIFOLD GS LEAKING 7)FAILED PARTS SAME 8)HISTORY NONE RELATED 9)ALL FLUIDS F/G 10)NO COM/COL/TOW MOD TIRE SIZE P275/45R20 AFTERMARKET WHEELS, STOCK 235/75R16 11)GOOD COND 12)LARRY SIGNED NO COMMENTS 13)LR 78.00 VERBAL END INSPECTION REPORT W SPOKE TO LARRY W. W ADV NO FAILURE VERIFIED TO THE RACK ANYTHING ELSE INSPECTOR CAN BE SHOWN STATED CAN NOT SHOW ANYTHING ELSE TO THE STRG RACK, ADV THE VEHICLE WILL NEED TO HAVE THE VEHICLE BROUGHT BACK TO MFG SPEC FOR THE TIRES FOR FUTURE DRIVETRAIN,STRG & SUSP COMPONENTS COVERAGE W ADV NEED TO REVIEW & CB Authorization Granted # [REDACTED] 524.75 W LARRY CALLING FROM THE I/D W TO CHECK STATUS OF THE CLAIM REVIEWED & GAVE THE ABOVE AUTH NUMBER W PENDING INVOICE FOR PAYMENT W LARRY CB W; ASKED TO ADD RENTAL W; WILL ADD/AUTH Authorization Granted # [REDACTED] 704.75 W TERRY, ID W INQ ON HOW TO SEND RA, ADV SHE CAN FAX TO # [REDACTED] W PE RA W; TERRY, ID CALLED W; INQ PAYMENT, ADV OF PAYMENT MADE W; PENDING CHECK PAYMENT W TERRY CALLING FROM ID WARR ADMIN W; NEEDS TO REVIEW TOTALS NO TAX ON CLAIM WILL ADD 8.25 PARTS ONLY W PE PAYMENT OF TAX Authorization Granted # [REDACTED] 822.39 W TERRY ID W CALLING IN REGARDS TO TAXES. STATES SHE HAD THEM AUTH. STILL LOOKING FOR PAYMENT I VIEWED PPWK IN NS TO MAKE SURE TAXES WERE BILLED AND ADV WILL GO OUT MONDAY AND AMT. APOLOGIZED PAYMENT NOT PROCESSED FOR TAXES. W PEND PAYMENT
CQIS Recommendations	

Tire Information			
Tire Manufacturer	Unknown	Tire Size	Unknown
Tire Brand Series		Wheel	
DOT Left Front		DOT Right Front	
DOT Left Rear		DOT Right Rear	
DOT Left Inner		DOT Right Inner	
DOT Spare			

Vehicle Information			
VIN	4F2YU06141K [REDACTED]	Engine Serial Number	887604086
Model Year	2001	Engine Description	3.0L DOHC EGI V6 NA*GAS
Transmission	4 SPD AUTO TRANS MAZDA CD4E	Vehicle Description	TRIBUTE
Body Cab Style	CA WE 5 DOOR LIGHT TRUCK	Drive Line	4 WHL L/H PART TIME DRIVE
Production Date	25-Apr-2001	Retail Sale Indicator Code	
Plant Description	KANSAS CITY PLANT BUILD	Reaquired Vehicle	
Build Region		Warranty Start Date	15-Aug-2001
Build Country Code		Transmission Serial Number	
Mileage	50142	Vehicle Axle Ratio	
Vehicle Restraint Code			

Disclaimer:

This data is for use as one of several potential "awareness" indicators for the Ford Motor Co. Enhanced Concern Identification System. It is unverified, draft, summary data generated from a computer "word search" of customer and technician symptom comments. Supplier data, technician and customer comments are unverified and actual root cause of any potential issue is not established by this summary.

[Contact ODRHELP](#)

Copyright 2001 Ford Motor Co All Rights Reserved

PE12-019

Mazda

9-6-2012

REQUEST NUMBER THREE
DOCUMENTS (SUBJECT)

Consumer Reports

Mazda CAC

ECI

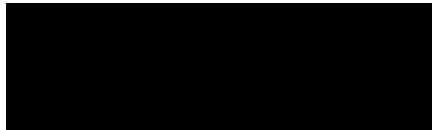

Commodity	powertrain-engine-base engine-seals and gaskets (not oil pan or head gasket)-	Symptom	mod-driving condition-while towing
Commodity	powertrain-engine-base engine-seals and gaskets (not oil pan or head gasket)-	Symptom	repair-mtime mentioned
Commodity	powertrain-engine-electronic engine control	Symptom	calibration-issue/re-flash
Commodity	powertrain-engine-electronic engine control	Symptom	damage
Commodity	powertrain-engine-electronic engine control	Symptom	damage-chafed/excessive wear
Commodity	powertrain-engine-electronic engine control	Symptom	damage-threads stripped/crossthreaded
Commodity	powertrain-engine-electronic engine control	Symptom	emissions-failed co
Commodity	powertrain-engine-electronic engine control	Symptom	engine power-stall
Commodity	powertrain-engine-electronic engine control	Symptom	field service action
Commodity	powertrain-engine-electronic engine control	Symptom	function-malfunction/inoperative
Commodity	powertrain-engine-electronic engine control	Symptom	improper assembly
Commodity	powertrain-engine-electronic engine control	Symptom	leak-failed gasket/seal/weatherstrip
Commodity	powertrain-engine-electronic engine control	Symptom	loose
Commodity	powertrain-engine-electronic engine control	Symptom	mod-driving condition-at start up
Commodity	powertrain-engine-electronic engine control	Symptom	mod-driving condition-engine-cold
Commodity	powertrain-engine-electronic engine control	Symptom	mod-driving condition-while towing
Commodity	powertrain-engine-electronic engine control	Symptom	repair-mtime mentioned
Commodity	powertrain-engine-electronic engine control	Symptom	separation
Commodity	powertrain-engine-electronic engine control	Symptom	sticks/binds/grabs
Commodity	powertrain-engine-miscellaneous controls	Symptom	damage
Commodity	powertrain-engine-miscellaneous controls	Symptom	damage-chafed/excessive wear
Commodity	powertrain-engine-miscellaneous controls	Symptom	damage-threads stripped/crossthreaded
Commodity	powertrain-engine-miscellaneous controls	Symptom	emissions-failed co
Commodity	powertrain-engine-miscellaneous controls	Symptom	engine power-stall
Commodity	powertrain-engine-miscellaneous controls	Symptom	field service action
Commodity	powertrain-engine-miscellaneous controls	Symptom	function-malfunction/inoperative
Commodity	powertrain-engine-miscellaneous controls	Symptom	improper assembly
Commodity	powertrain-engine-miscellaneous controls	Symptom	leak-failed gasket/seal/weatherstrip
Commodity	powertrain-engine-miscellaneous controls	Symptom	loose
Commodity	powertrain-engine-miscellaneous controls	Symptom	mod-driving condition-at start up
Commodity	powertrain-engine-miscellaneous controls	Symptom	mod-driving condition-engine-cold
Commodity	powertrain-engine-miscellaneous controls	Symptom	mod-driving condition-while towing
Commodity	powertrain-engine-miscellaneous controls	Symptom	repair-mtime mentioned
Commodity	powertrain-engine-miscellaneous controls	Symptom	sticks/binds/grabs
Commodity	powertrain-engine-oil system-oil pan and crank sealing-	Symptom	damage
Commodity	powertrain-engine-oil system-oil pan and crank sealing-	Symptom	damage-chafed/excessive wear
Commodity	powertrain-engine-oil system-oil pan and crank sealing-	Symptom	damage-threads stripped/crossthreaded
Commodity	powertrain-engine-oil system-oil pan and crank sealing-	Symptom	emissions-failed co
Commodity	powertrain-engine-oil system-oil pan and crank sealing-	Symptom	engine power-stall
Commodity	powertrain-engine-oil system-oil pan and crank sealing-	Symptom	field service action
Commodity	powertrain-engine-oil system-oil pan and crank sealing-	Symptom	function-malfunction/inoperative
Commodity	powertrain-engine-oil system-oil pan and crank sealing-	Symptom	improper assembly
Commodity	powertrain-engine-oil system-oil pan and crank sealing-	Symptom	leak-failed gasket/seal/weatherstrip
Commodity	powertrain-engine-oil system-oil pan and crank sealing-	Symptom	leak-oil
Commodity	powertrain-engine-oil system-oil pan and crank sealing-	Symptom	loose
Commodity	powertrain-engine-oil system-oil pan and crank sealing-	Symptom	mod-driving condition-at start up
Commodity	powertrain-engine-oil system-oil pan and crank sealing-	Symptom	mod-driving condition-engine-cold
Commodity	powertrain-engine-oil system-oil pan and crank sealing-	Symptom	mod-driving condition-while towing
Commodity	powertrain-engine-oil system-oil pan and crank sealing-	Symptom	repair-mtime mentioned
Commodity	powertrain-engine-oil system-oil pan and crank sealing-	Symptom	separation
Significant Event		Verified	N

Tread Information

Reported in Tread Quarter Q4 2005

Report Details

Source Claim Key		Warranty Component Classification (WCC)	
Corporate Product Systems Classification (CPS)		Time in Service	
Customer Condition Code		V Function Group (VFG)	
Source System Program Type		Repair/Report/Paid Date	06-Dec-2005
Version Series Code	AAAA5	Load Date	28 -Dec-2005
Causal Part Prefix- Base - Suffix	-	Dealer Code	
Causal Part Name	NOT PROVIDED BY SOURCE	Dealer Name	NOT PROVIDED BY SOURCE
Non Causal Part Prefix-Base-Suffix		Dealer City	
Non Causal Part Numbers		Dealer State/Province	
Fault Code		Dealer Country	USA
Diagnostic Trouble Code		Dealer Phone Number	
Labor Operation Code		Attachment	
Communication Type		VOQ Component Description Code	
Maintenance Date	28 -Dec-2005		

Customer Comment

Technician Comment	<p>Complaint OIL PAN GASKET Comment OIL PAN GASKET Notes C; STALLING C IAC VALE INTERNAL FIALURE, T BODY HAS INTERNAL MECHANICAL FIALURE C REPLACE VALVE (T BODY NCP) C; TECH FOUND C OIL PAN LEAKING FROM DRAIN PLUG BOSS BUT NOT STRIPED AS PER STEVE FRONT CRAS LEAKING C REPLACE OIL PAN AND FRONT CRANK SEAL NOC STEVE DID NOT HAVE EST FOR THE REPAIR OF THE OIL PAN AND FRONT CRAS, HE WILL CB ADVISED BASED ON THE OIL PAN NOT STRIPPED WE WOULD NEED TO INSPECT TO VERIFY FIALURE NO AUTH GIVEN W STSVE CB W HAD PART EST, NJO LABOR WILL LOOK UP IN WARRANTY WIZARD AND INSPECT W WILL INSPECT W STSTEV CB W A SKED XABOUT DE W REVIEW ENO DED INSPECTION REPORT 1. LEE JOSEPHS CARR [REDACTED] 2. MILEAGE 86,902 VIN M20885 MATCH C/H MILTON GRAUS 3. ENG 3.0 V 6 TRANS AUTO 4WD 4. CC STALLS ON STARTING OR STOPPING 5. FINDINGS T/D IAC & AIR INLET TUBE REMOVED VEHICLE ON LIFT OIL PAN GASKET LEAKING OIL TO A DRIP FRT CRANK SEAL SEEPING NOT ACTIVE LEAK TECH DRAINED OIL PAN THREADS WORN APPEARS PAN HAS HAD PLUG OVER TORQUED AND THREADS DAMAGED TECH HAS IAC OFF THROTTLE BODY IS CARBONED NEEDS TO BE CLEANED STATES IAC VALVE IS STUCK INSPECTOR ABLE TO MOVE VALVE HAS LIGHT CARBON NO CODES STORED, NO CK ENG LIGHT ON NO OTHER FAILURES SEEN OR DEMO'D 6. COF THREAD DAMAGE TO OIL PAN FROM WEAR & USE/OVERTORQUE SEAL FAILURE TO OIL PAN GASKET 7. FAILED PARTS OIL PAN GASKET OIL PAN PHY DAMAGE 8. HISTORY NONE RELATED 9. FLUIDS OIL DRAINED/GOOD, COOL/ATF F/G, STRG/BRK F/G 10. OVERALL GOOD 11. NO M/C/C TOW FACTORY NOT USED 12 LABOR \$80 V 13. SIGNED STEVE NO ADDS OR COMMENTS END OF REPORT STEVE N/A WILL C/B W AUTH PE C/B TO REVIEW NO COVERABLE COF VERIFIED TO IAC, T/BDY, OIL PAN OR FRTC Authorization Granted # [REDACTED] 150.95 W CALLING ID STEVE W REVIEW PARTS & LABOR ID STATES VALVE IS STUCK, DOES NOT AGREE WITH FINDINGS WANTS TO SPEAK TO SUPERVISOR DON N/A ADVISED ID WILL LEAVE MESSAGE FOR C/B STEVES ext 1875 W EMAIL DON FOR C/B CORRECTION EMAIL DAN J W REC EMAIL TO CALL SHOP BACK W CALLED INSP, TECH WAS THERE AND SAY THE VALVE MOVE, TECH CLAIMS IT IS STUCK I T IS STUCK IN THE SOLENOID. WOULD NEED TO REINSTALL IT TO TEST IT. CALLED STEVE EBERS WENT TO VOICE MAIL, ADV IF THEY FEEL PART IS FAILED TO REI NSTALL IT AND WE COULD REINSPECT THE FAILURE. W PEND CALL BACK IF PART IS FAILED W STEVE CALLING FROM THE I/D W TO SPEAK WITH DAN OFFERED MY ASSISTANCE & ADVISED PER ABOVE NOTES TO REINSTALL THE VALVE & WE COULD REINSPECT,STEVE SAYS THEY WILL NOT REINSTALL A PART THAT THE INSPECTOR HAD THEM REMOVE.I ADVISED PER THE INSPECTION REPORT THE VALVE WAS ALREADY REMOVED. STEVE DOES NOT AGREE & WANTS TO SPEAK WITH DAN. W SPOKE WITH & TRANS TO DAN W SPOKE TO STEVE AGAIN, HE SAID THE INSPECTOR ASKED TECH TO TAKE THE VALVE OFF THE CAR, I CALLED THE INSPECTOR HE SAID HE HAD THEM REMOVE THE AIR TUBE BUT THE IAC VALVE WAS ALREADY OFF. i ADV STEVE EBER AT THE ID THAT WE WILL HAVE TO HAVE THE PART REINSTALLED AND CONFRIM A FAILURE TO IT. ADV NO OTHER OPTION. HE THEN A SKED ABOUT THE OIL PAN, ADV THREADS DAMAGED FROM BEING OVER TIGHTENED. HE SAID T HE THREADS ARE WORN FROM CHANGING THE OIL. ADV WE COULD LOOK AT THE PICTURES OF THIS AND SEE IF THERE WAS ANY SIGN OF WEAR ONLY. HE THEN ASKED FOR MY BOSS CAUSE HE DOES NOT ACCEPT THIS. ADV WILL REQUEST HIM TO CALL BACK AS THEY ARE IN MEETI GS. W EMAIL STEVE M TO CALL SA w CALLING THE ID FOR STEVE EBERS W VOICE MAIL.....LEFT VOICE MESSAGE THAT THE THREADS APPEAR PER THE REPORT TO BE DAMAGED AND NOT COVERABLE AND THE IAC SEEMS TO BE CARBONED, AGAIN NOT A COVERED FAILURE....WILL BE HAPPY TO LOOK AT THE PICTURES BUT THAT WILL NOT TAKE PLACE UNTIL TOMORROW..... STEVE....CALLED NOW....SAYS THAT THE VALVE STUCK....COULD BE MOVED WITH A PEN....BUT HE THINKS THAT THE FAILURE IS NOT DUE TO CARBON....SAYS THERE IS NOT EXTENSIVE CARBON HERE, AND THAT ALL CARS CREATE CARBON...NOT EXCESSIVE I TOLD HIM THAT THE MAJORITY OF IAC FAILURES ARE DUE TO CARBON, AND IF WE TOOK THE CARBON OUR OF THE PICTURE WOULD THE VALVE BE STICKING,...HE THINKS IT WOULD, WHEN I ASKED WHY, HE DOESN:T KNOW WHY....TOLD HIM WE HAVE TO BE ABLE TO NOTE A MATERIAL FAILURE, AND IF HE CAN:T TELL WHY, THEN WE CAN'T HELP.....HE ASKED THAT I LOOK AT ALL THE PICTURES IN THE MORNING AND CALL HIM BACK....WILL DO W WILL CALL ID BACK AFTER PIC REVIEW IN AM W CH MILTON GRAUS W CH STATES THAT HAVING PROBLEM CH STATES THAT TOOK VEH TO DEALERSHIP THEY DIAG WHATEVER THEY THINK PROBLEM AND THERE IS SOMETHING BC WE HAVE NOT APPROVED ADV CH THAT WE HAVE AUTH OIL PAN GASKET EXPL TO CH THAT AS FOR IAC VALVE WE HAVE DENIED DUE TO A NON COV;D COF EXPL TO CH THAT UNDER CONTRACT HAS TO BE DEFECT IN MAT. OR WRKMHSP ONLY IF NOT WE CAN NOT ASSIST W PEND REVIEW W STEVE CALLING FROM ID W CALLING TO CONT CLAIM ASKING IF stevem HAS VIEWED PICS. ADV NO NOTES SHOWING THAT HE HAS YET. REV'D WHAT HAS BEEN AUTHED IN NF5 W PAY PEND PW PE REV OF PICS. W CALLING THE ID BACK W REVIEWED PICS AND REPORT....NO DEFECT IN MATERIALS...THREADS IN THE PAN HAVE BEEN PULLED OUT, AND THERE WAS NOTHING SHOWN DEFECTIVE TO THE IAC.... TOLD STEVE THERE IS A TSB THAT DESCRIBES THIS SITUATION AND ONE OF THE PROCEEDURES IS TO RE FLASH THE PCM....AN ADJUSTMENT STEVE SAYS THAT THEY HAVE SPOKEN WITH THEIR MAZDA REP WHO SUPPORTS THEM AND NOT OUR DECISION AND HE HAS TAKEN MY NAME AND NUMBERBUT MAZDA WILL COVER THIS AT THIS TIME ASKED FOR AUTH NUMBER AND AMOUNTS....GAVE HIM THE INFO W PENDING RO FOR PAYMENT ON OIL PAN GASKET ONLY RECD RO W/O ID INFO, FWD TO ERICA FOR RS RESUB LETTER... W; KAREN ID W; NEED FAX NUMBER TO SUBMIT RS INFO GAVE FAX 2468 W; PEND PPWK</p>
CQIS Recommendations	

Tire Information			
Tire Manufacturer	Unknown	Tire Size	Unknown
Tire Brand Series		Wheel	
DOT Left Front		DOT Right Front	
DOT Left Rear		DOT Right Rear	
DOT Left Inner		DOT Right Inner	
DOT Spare			

Vehicle Information			
VIN	4F2CU081X1K [REDACTED]	Engine Serial Number	603519087
Model Year	2001	Engine Description	3.0L DOHC EGI V6 NA *GAS
Transmission	4 SPD AUTO TRANS MAZDA CD4E	Vehicle Description	TRIBUTE
Body Cab Style	CA WE 5 DOOR LIGHT TRUCK	Drive Line	4 WHL L/H PART TIME DRIVE
Production Date	28-Sep-2000	Retail Sale Indicator Code	
Plant Description	KANSAS CITY PLANT BUILD	Required Vehicle	
Build Region		Warranty Start Date	20-Oct-2000
Build Country Code		Transmission Serial Number	
Mileage	86902	Vehicle Axle Ratio	
Vehicle Restraint Code			

Disclaimer:

This data is for use as one of several potential "awareness" indicators for the Ford Motor Co. Enhanced Concern Identification System. It is unverified, draft, summary data generated from a computer "word search" of customer and technician symptom comments. Supplier data, technician and customer comments are unverified and actual root cause of any potential issue is not established by this summary.

[Contact ODRHELP](#)

Copyright 2001 Ford Motor Co All Rights Reserved

PE12-019

Mazda

9-6-2012

REQUEST NUMBER THREE
DOCUMENTS (SUBJECT)

Consumer Reports

Mazda CAC

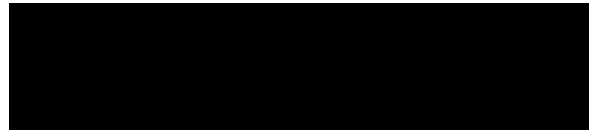



Concern Driven Reporting

Report Detail

Note: Field which are grayed (ghosted) are currently being mapped to the data warehouse. They are not presently being populated.

ECI Record		Source Code	MAZDA CAC
Commodity Assignment			
Commodity	powertrain-engine—	Symptom	contaminated/foreign
Commodity	powertrain-engine—	Symptom	function-malfunction/inoperative
Commodity	powertrain-engine—	Symptom	mod-driving condition-while towing
Commodity	powertrain-engine—	Symptom	no keyword found
Commodity	powertrain-engine—	Symptom	nvh-noisy operation
Commodity	powertrain-engine-accel pedal/linkage/controls—	Symptom	engine rpm surge/flare
Commodity	powertrain-engine-accel pedal/linkage/controls—	Symptom	frozen/seized
Commodity	powertrain-engine-accel pedal/linkage/controls—	Symptom	function-malfunction/inoperative
Commodity	powertrain-engine-accel pedal/linkage/controls—	Symptom	mod-driving condition-while driving
Commodity	powertrain-engine-accel pedal/linkage/controls—	Symptom	mod-vehicle towed in
Commodity	powertrain-engine-accel pedal/linkage/controls—	Symptom	nvh-noisy operation
Commodity	powertrain-engine-accel pedal/linkage/controls—	Symptom	sticks/binds/grabs
Commodity	powertrain-engine-base engine—	Symptom	frozen/seized
Commodity	powertrain-engine-base engine—	Symptom	function-malfunction/inoperative
Commodity	powertrain-engine-base engine—	Symptom	mod-driving condition-at cruise
Commodity	powertrain-engine-base engine—	Symptom	mod-driving condition-while driving
Commodity	powertrain-engine-base engine—	Symptom	nvh-noisy operation
Commodity	powertrain-engine-base engine-seals and gaskets (not oil pan or head gasket)-	Symptom	engine rpm surge/flare
Commodity	powertrain-engine-base engine-seals and gaskets (not oil pan or head gasket)-	Symptom	function-malfunction/inoperative
Commodity	powertrain-engine-base engine-seals and gaskets (not oil pan or head gasket)-	Symptom	mod-driving condition-while driving
Commodity	powertrain-engine-base engine-seals and gaskets (not oil pan or head gasket)-	Symptom	mod-vehicle towed in
Commodity	powertrain-engine-base engine-seals and gaskets (not oil pan or head gasket)-	Symptom	nvh-noisy operation
Significant Event		Verified	N

Tread Information

Reported in Tread Quarter Q2 2006

Report Details

Source Claim Key		Warranty Component Classification (WCC)	
Corporate Product Systems Classification (CPSC)		Time in Service	53
Customer Condition Code		V Function Group (VFG)	
Source System Program Type		Repair/Report/Paid Date	25-Apr-2006
Version Series Code	AAAAA5	Load Date	30-Apr-2006
Causal Part Prefix-Base-Suffix	-	Dealer Code	23901
Causal Part Name	NOT PROVIDED BY SOURCE	Dealer Name	SOUTHERN STATES MAZDA
Non Causal Part Prefix-Base-Suffix		Dealer City	RALEIGH
Non Causal Part Numbers		Dealer State/Province	NC
Fault Code		Dealer Country	USA
Diagonstic Trouble Code		Dealer Phone Number	9198397481
Labor Operation Code		Attachment	
Communication Type		VOQ Component Description Code	
Maintenance Date	30-Apr-2006		

Customer Comment CST DAUGHTER CALLED STS SHE WAS DRIVING VEH FROM MD TO NC HER BOYFRIND PESS ON THROTTLE & GOT STUCK VEH TOWED TO DLR AND THEY NOTICE THE CRUISE CONTROL CABLE WAS HANGING & STUCK ON ENG COVER DLR STS THERE WAS TO MUCH PLAY ON CABLE THEY REPAIRED & ADV CUST SHE NEED A OIL CHG CST ASKED IF SHE COULD WAIT UNTIL SHE GOT TO NC AND DLR STS IT WAS DIRTY BUT SHE COULD DRIVE THE 4 HRS HOME THEY ADV IT WAS OK. CST STS 1 1/2 HR OF DRIVING THERE WAS A KNOCKING NOISE,& THE VEH SEIZED.

Technician Comment	0042006 04 26CRPC582 DCSM DECLINE REPAIRS SOUTHERN STATES MAZDA IS OFFERING DISCOUNT FOR REPAIRS AND CUSTOMER SEEMS TO BE SATIFED WITH DISCOUNT 0032006 04 25CRPC582 IN JULY OF 05 CALLED CUST AND LEFT MESSAGE ON VOICE MAIL ADVISING HER I WAS SENDING FILE TO DLR AND THEY WILL CONTACT THE REP. FOR ASST. 0022006 04 25CRPC582 AND NOTED AT DLR PAPER WORK NOT ON CUST WORK ORDER. CALLED SOUTHERN STATES MZ AND TT ASHLEY AND HE STS THAT THE VEH HAS METAL IN THE OIL AND ENG STS VEH JUST NEEDS NEW ENG CUST STS THAT FATHER CALLED AND STS DAUGHTER DID NOT HEAR A KNOCKIN NOISE UNTIL SHE LEFT DLR. HE DOES NT KNOW HOW SHE COULD NOT OF HEARD ANYTHING WITH ALL THE METAL AND STS VEH WAS ALL INTACT WHEN IT ARRIVED BY TOW. HE STS HE GAVE CUST 2 OPTIONS A MZ REMAN ENG OR A USED ENG. CUST HAS NOT GOTTEN BACK TO HIM LOOKING AT CUST VEH HISTORY VEH ONLY AT THIS DLR 1 X 0012006 04 25CRPC582 AT ATTN DCSM/SVM PER OUR CONVERSATION, PLEASE REVIEW CONCERNS ON VEH. PLEASE CONTACT THE DCSM FOR POSSIBLE GOODWILL. PLEASE CLOSE WITH NOTES UPON RESOLUTION. THANKS. KAREN 949 727 6797 REQ DESC ENG SEIZED CALLED DLR TT DOMINGO SERV MRG. AND HE STS THAT THEY ADDRESSED CUST CONCERN ON THE CRUISE CONTROL CABLE, HE STS THAT IF THEY DID THE OIL CHG ON VEH THEY MIGHT OF NOTICE A PROBLEM. BUT CUST DID NOT WANT A OIL CHG. TECH DID HEARD NOISE IN VEH DCSM DECLINE REPAIRS SOUTHERN STATES MAZDA IS OFFERING DISCOUNT FOR REPAIRS AND CUSTOMER SEEMS TO BE SATIFED WITH DISCOUNT ATTN DCSM/SVM PER OUR CONVERSATION, PLEASE REVIEW CONCERNS ON VEH. PLEASE CONTACT THE DCSM FOR POSSIBLE GOODWILL. PLEASE CLOSE WITH NOTES UPON RESOLUTION. THANKS. KAREN 949 727 6797
CQIS Recommendations	

Tire Information

Tire Manufacturer	Unknown	Tire Size	Unknown
Tire Brand Series		Wheel	
DOT Left Front		DOT Right Front	
DOT Left Rear		DOT Right Rear	
DOT Left Inner		DOT Right Inner	
DOT Spare			

Vehicle Information

VIN	4F2YU08142K	Engine Serial Number	191426086
Model Year	2002	Engine Description	3.0L DOHC EGI V6 NA *GAS
Transmission	4 SPD AUTO TRANS MAZDA CD4E	Vehicle Description	TRIBUTE
Body Cab Style	CA WE 5 DOOR LIGHT TRUCK	Drive Line	4 WHL L/H PART TIME DRIVE
Production Date	06-Dec-2001	Retail Sale Indicator Code	
Plant Description	KANSAS CITY PLANT BUILD	Reaquired Vehicle	
Build Region		Warranty Start Date	28-Dec-2001
Build Country Code		Transmission Serial Number	
Mileage	68000	Vehicle Axle Ratio	
Vehicle Restraint Code			

Disclaimer:

This data is for use as one of several potential "awareness" indicators for the Ford Motor Co. Enhanced Concern Identification System. It is unverified, draft, summary data generated from a computer "word search" of customer and technician symptom comments. Supplier data, technician and customer comments are unverified and actual root cause of any potential issue is not established by this summary.

Contact CDRHELP
Copyright 2001 Ford Motor Co All Rights Reserved

PE12-019

MADZA

9/6/2012

APPENDIX 3 SUBJECT
VEHICLES

Consumer Reports

VOQ Mazda

ECI

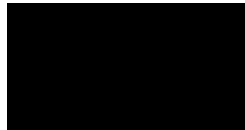



Concern Driven Reporting

Report Detail

Note: Field which are grayed (ghosted) are currently being mapped to the data warehouse. They are not presently being populated.

ECI Record		Source Code	VOQ Mazda
------------	--	-------------	-----------

Commodity Assignment			
Commodity	powertrain-engine-accel pedal/linkage/controls	Symptom	function-malfunction/inoperative
Commodity	powertrain-engine-accel pedal/linkage/controls	Symptom	mod-driving condition-while driving
Commodity	powertrain-engine-accel pedal/linkage/controls	Symptom	sticks/binds/grabs
Significant Event		Verified	N

Tread Information

Report Details

Source Claim Key	ODI 891605	Warranty Component Classification (WCC)	
Corporate Product Systems Classification (CPSC)		Time in Service	
Customer Condition Code		V Function Group (VFG)	
Source System Program Type		Repair/Report/Paid Date	23-Jun-2001
Version Series Code	UNKN	Load Date	01-Apr-2004
Causal Part Prefix- Base - Suffix	-	Dealer Code	
Causal Part Name	NOT PROVIDED BY SOURCE	Dealer Name	NOT PROVIDED BY SOURCE
Non Causal Part Prefix-Base-Suffix		Dealer City	
Non Causal Part Numbers		Dealer State/Province	
Fault Code		Dealer Country	USA
Diagnostic Trouble Code		Dealer Phone Number	
Labor Operation Code		Attachment	
Communication Type		VOQ Component Description Code	
Maintenance Date	01-Apr-2004		

Customer Comment	VEHICLE WAS GOING 10 15MPH AND STEPPED ON GAS TO GO 20 25MPH. AND RPMS WERE STICKING,AND BRAKING MADE IT 80 85% LESS EFFECTIVE. DEALER IS CONVINCED THE PROBLEM IS THE FLOOR MATS.
Technician Comment	
CQIS Recommendations	

Tire Information

Tire Manufacturer	Unknown	Tire Size	Unknown
Tire Brand Series		Wheel	
DOT Left Front		DOT Right Front	
DOT Left Rear		DOT Right Rear	
DOT Left Inner		DOT Right Inner	
DOT Spare			

Vehicle Information

VIN	UNK TRIBUTE	Engine Serial Number	UNKNOWN
Model Year	2001	Engine Description	Unknown
Transmission	Unknown	Vehicle Description	TRIBUTE
Body Cab Style	UNKN Unknown	Drive Line	Unknown
Production Date		Retail Sale Indicator Code	
Plant Description	Unknown	Reaquired Vehicle	
Build Region		Warranty Start Date	
Build Country Code		Transmission Serial Number	UNKNOWN
Mileage	0	Vehicle Axle Ratio	
Vehicle Restraint Code			

Disclaimer:

This data is for use as one of several potential "awareness" indicators for the Ford Motor Co. Enhanced Concern Identification System. It is unverified, draft, summary data generated from a computer "word search" of customer and technician symptom comments. Supplier data, technician and customer comments are unverified and actual root cause of any potential issue is not established by this summary.

[Contact ODR Help](#)

PE12-019

MADZA

9/6/2012

APPENDIX 3 SUBJECT
VEHICLES

Consumer Reports

VOQ Mazda

ECI

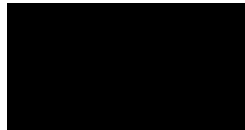



Concern Driven Reporting

Report Detail

Note: Field which are grayed (ghosted) are currently being mapped to the data warehouse. They are not presently being populated.

ECI Record	██████████	Source Code	VOQ Mazda
------------	------------	-------------	-----------

Commodity Assignment			
Commodity	powertrain-engine-accel pedal/linkage/controls	Symptom	pedal concerns-accelerator pedal
Significant Event	Property Damage;	Verified	N

Tread Information

Report Details

Source Claim Key	██████████ ODI 10015759	Warranty Component Classification (WCC)	
Corporate Product Systems Classification (CPSC)		Time in Service	
Customer Condition Code		V Function Group (VFG)	
Source System Program Type		Repair/Report/Paid Date	11-Apr-2003
Version Series Code	AAAQK	Load Date	01-Apr-2004
Causal Part Prefix-Base-Suffix	-	Dealer Code	
Causal Part Name	NOT PROVIDED BY SOURCE	Dealer Name	NOT PROVIDED BY SOURCE
Non Causal Part Prefix-Base-Suffix		Dealer City	
Non Causal Part Numbers		Dealer State/Province	
Fault Code		Dealer Country	USA
Diagonstic Trouble Code		Dealer Phone Number	
Labor Operation Code		Attachment	
Communication Type		VOQ Component Description Code	
Maintenance Date	01-Apr-2004		

Customer Comment	THE CONSUMER PUT THE GEAR SHIFT IN THE DRIVE GEAR. WHEN THE DRIVER TAPPED THE ACCELERATOR PEDAL THE VEHICLE ACCELERATED IN FULL THROTTLE. *NLM *TS
Technician Comment	
C Q I S	
Recommendations	

Tire Information

Tire Manufacturer	Unknown	Tire Size	Unknown
Tire Brand Series		Wheel	
DOT Left Front		DOT Right Front	
DOT Left Rear		DOT Right Rear	
DOT Left Inner		DOT Right Inner	
DOT Spare			

Vehicle Information

VIN	4F2CU08141K ██████████	Engine Serial Number	917979087
Model Year	2001	Engine Description	3.0L DOHC EGI V6 NA*GAS
Transmission	4 SPD AUTO TRANS MAZDA CD4E	Vehicle Description	TRIBUTE
Body Cab Style	CA WE 5 DOOR LIGHT TRUCK	Drive Line	4 WHL L/H PART TIME DRIVE
Production Date	24-May-2001	Retail Sale Indicator Code	
Plant Description	KANSAS CITY PLANT BUILD	Reaquired Vehicle	
Build Region		Warranty Start Date	11-Jun-2001
Build Country Code		Transmission Serial Number	
Mileage	29000	Vehicle Axle Ratio	
Vehicle Restraint Code			

Disclaimer:

This data is for use as one of several potential "awareness" indicators for the Ford Motor Co. Enhanced Concern Identification System. It is unverified, draft, summary data generated from a computer "word search" of customer and technician symptom comments. Supplier data, technician and customer comments are unverified and actual root cause of any potential issue is not established by this summary.

PE12-019

MADZA

9/6/2012

APPENDIX 3 SUBJECT
VEHICLES

Consumer Reports

VOQ Mazda

ECI

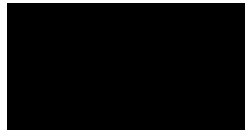



Concern Driven Reporting

Report Detail

Note: Field which are grayed (ghosted) are currently being mapped to the data warehouse. They are not presently being populated.

ECI Record		Source Code	VOQ Mazda
------------	--	-------------	-----------

Commodity Assignment

Commodity	powertrain-engine-accel pedal/linkage/controls	Symptom	function-malfunction/inoperative
Commodity	powertrain-engine-accel pedal/linkage/controls	Symptom	mod-driving condition-on acceleration
Commodity	powertrain-engine-accel pedal/linkage/controls	Symptom	mod-driving condition-while driving
Commodity	powertrain-engine-accel pedal/linkage/controls	Symptom	pedal concerns-accelerator pedal
Commodity	powertrain-engine-accel pedal/linkage/controls	Symptom	sticks/binds/grabs
Significant Event		Verified	N

Tread Information

Report Details

Source Claim Key		ODI I00I0623	Warranty Component Classification (WCC)	
Corporate Product Systems Classification (CPS)			Time in Service	
Customer Condition Code			V Function Group (VFG)	
Source System Program Type			Repair/Report/Paid Date	12-Feb-2003
Version Series Code	AAAA5		Load Date	01-Apr-2004
Causal Part Prefix-Base-Suffix	-		Dealer Code	
Causal Part Name	NOT PROVIDED BY SOURCE		Dealer Name	NOT PROVIDED BY SOURCE
Non Causal Part Prefix-Base-Suffix			Dealer City	
Non Causal Part Numbers			Dealer State/Province	
Fault Code			Dealer Country	USA
Diagnostic Trouble Code			Dealer Phone Number	
Labor Operation Code			Attachment	
Communication Type			VOQ Component Description Code	
Maintenance Date	01-Apr-2004			

Customer Comment	THROTTLE STICKS WHEN ACCELERATING FROM COMPLETE STOP DUE TO BUILD UP ON THROTTLE PLATE. OWNER HAS PROVIDED MAINTENANCE AND FUEL AS SPECIFIED IN MANUAL, YET WAS TOLD MAZDA DOES NOT COVER UNDER WARRANTY. PROBLEM APPEARED WITH LESS THAN 15000 MILES. CLEANING (AT OWNER COST) PROVIDES ONLY SHORT TERM REMEDY. *NLM
Technician Comment	
CQIS Recommendations	

Tire Information

Tire Manufacturer	Unknown	Tire Size	Unknown
Tire Brand Series		Wheel	
DOT Left Front		DOT Right Front	
DOT Left Rear		DOT Right Rear	
DOT Left Inner		DOT Right Inner	
DOT Spare			

Vehicle Information

VIN	4F2CU08122K	Engine Serial Number	311584087
Model Year	2002	Engine Description	3.0L DOHC EGI V6 NA*GAS
Transmission	4 SPD AUTO TRANS MAZDA CD4E	Vehicle Description	TRIBUTE
Body Cab Style	CA WE 5 DOOR LIGHT TRUCK	Drive Line	4 WHL L/H PART TIME DRIVE
Production Date	01-Mar-2002	Retail Sale Indicator Code	
Plant Description	KANSAS CITY PLANT BUILD	Required Vehicle	
Build Region		Warranty Start Date	28-Mar-2002
Build Country Code		Transmission Serial Number	
Mileage	0	Vehicle Axle Ratio	
Vehicle Restraint Code			

Disclaimer:

This data is for use as one of several potential "awareness" indicators for the Ford Motor Co. Enhanced Concern Identification System. It is unverified, draft, summary data generated from a computer "word search" of customer and technician symptom comments. Supplier data, technician and customer comments are unverified and actual root cause of any potential issue is not established by this summary.

[Contact ODRHELP](#)

Copyright 2001 Ford Motor Co All Rights Reserved

PE12-019

MADZA

9/6/2012

APPENDIX 3 SUBJECT
VEHICLES

Consumer Reports

VOQ Mazda

ECI

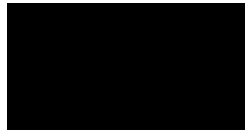



Concern Driven Reporting

Report Detail

Note: Field which are grayed (ghosted) are currently being mapped to the data warehouse. They are not presently being populated.

ECI Record		Source Code	VOQ Mazda
------------	--	-------------	-----------

Commodity Assignment

Commodity	powertrain-engine-accel pedal/linkage/controls	Symptom	mod-driving condition-on acceleration
Commodity	powertrain-engine-accel pedal/linkage/controls	Symptom	mod-driving condition-while driving
Commodity	powertrain-engine-accel pedal/linkage/controls	Symptom	mod-no indication (sudden)
Commodity	powertrain-engine-accel pedal/linkage/controls	Symptom	unintended acceleration
Significant Event	Property Damage;	Verified	N

Tread Information

Report Details

Source Claim Key	ODI 10033988	Warranty Component Classification (WCC)	
Corporate Product Systems Classification (CPSC)		Time in Service	
Customer Condition Code		V Function Group (VFG)	
Source System Program Type		Repair/Report/Paid Date	14-Aug-2003
Version Series Code	UNKN	Load Date	01-Apr-2004
Causal Part Prefix-Base-Suffix	-	Dealer Code	
Causal Part Name	NOT PROVIDED BY SOURCE	Dealer Name	NOT PROVIDED BY SOURCE
Non Causal Part Prefix-Base-Suffix		Dealer City	
Non Causal Part Numbers		Dealer State/Province	
Fault Code		Dealer Country	USA
Diagonstic Trouble Code		Dealer Phone Number	
Labor Operation Code		Attachment	
Communication Type		VOQ Component Description Code	
Maintenance Date	01-Apr-2004		

Customer Comment	VEHICLE EXPERIENCED SUDDEN ACCELERATION WHILE DRIVING AT THE PARKING LOT, AND VEHICLE COLLIDED WITH A BRICK WALL, SMASHING THE FRONT. DEALER NOTIFIED. *AK
Technician Comment	
C Q I S Recommendations	

Tire Information

Tire Manufacturer	Unknown	Tire Size	Unknown
Tire Brand Series		Wheel	
DOT Left Front		DOT Right Front	
DOT Left Rear		DOT Right Rear	
DOT Left Inner		DOT Right Inner	
DOT Spare			

Vehicle Information

VIN	UNK TRIBUTE	Engine Serial Number	UNKNOWN
Model Year	2002	Engine Description	Unknown
Transmission	Unknown	Vehicle Description	TRIBUTE
Body Cab Style	UNKN Unknown	Drive Line	Unknown
Production Date		Retail Sale Indicator Code	
Plant Description	Unknown	Reaquired Vehicle	
Build Region		Warranty Start Date	
Build Country Code		Transmission Serial Number	UNKNOWN
Mileage	0	Vehicle Axle Ratio	
Vehicle Restraint Code			

Disclaimer:

This data is for use as one of several potential "awareness" indicators for the Ford Motor Co. Enhanced Concern Identification System. It is unverified, draft, summary data generated from a computer "word search" of customer and technician symptom comments. Supplier data, technician and customer comments are unverified and actual root cause of any potential issue is not established by this summary.

PE12-019

MADZA

9/6/2012

APPENDIX 3 SUBJECT
VEHICLES

Consumer Reports

VOQ Mazda

ECI

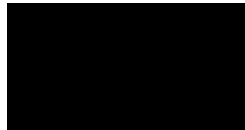



Concern Driven Reporting

Report Detail

Note: Field which are grayed (ghosted) are currently being mapped to the data warehouse. They are not presently being populated.

ECI Record	██████████	Source Code	VOQ Mazda
------------	------------	-------------	-----------

Commodity Assignment			
Commodity	powertrain-engine-accel pedal/linkage/controls	Symptom	engine power-hesitates
Commodity	powertrain-engine-accel pedal/linkage/controls	Symptom	mod-no indication (sudden)
Commodity	powertrain-engine-accel pedal/linkage/controls	Symptom	pedal concerns-accelerator pedal
Commodity	powertrain-engine-accel pedal/linkage/controls	Symptom	unintended acceleration
Significant Event		Verified	N

Tread Information

Report Details

Source Claim Key	██████████ ODI 10027270	Warranty Component Classification (WCC)	
Corporate Product Systems Classification (CPSC)		Time in Service	
Customer Condition Code		V Function Group (VFG)	
Source System Program Type		Repair/Report/Paid Date	14-Jul-2003
Version Series Code	AAAAX	Load Date	01-Apr-2004
Causal Part Prefix-Base-Suffix	- -	Dealer Code	
Causal Part Name	NOT PROVIDED BY SOURCE	Dealer Name	NOT PROVIDED BY SOURCE
Non Causal Part Prefix-Base-Suffix		Dealer City	
Non Causal Part Numbers		Dealer State/Province	
Fault Code		Dealer Country	USA
Diagonstic Trouble Code		Dealer Phone Number	
Labor Operation Code		Attachment	
Communication Type		VOQ Component Description Code	
Maintenance Date	01-Apr-2004		

Customer Comment	CONSUMER DEPRESSED ACCELERATOR PEDAL AND VEHICLE HESITATED, AND THEN SUDDENLY LURCHED FORWARD, ALMOST CAUSING A COLLISION. RELATED INVESTIGATION EA 02 027.*AK		
Technician Comment			
C Q I S Recommendations			

Tire Information

Tire Manufacturer	Unknown	Tire Size	Unknown
Tire Brand Series		Wheel	
DOT Left Front		DOT Right Front	
DOT Left Rear		DOT Right Rear	
DOT Left Inner		DOT Right Inner	
DOT Spare			

Vehicle Information

VIN	4F2YU07121K ██████████	Engine Serial Number	746173086
Model Year	2001	Engine Description	3.0L DOHC EGI V6 NA*GAS
Transmission	4 SPD AUTO TRANS MAZDA CD4E	Vehicle Description	TRIBUTE
Body Cab Style	CA WE 5 DOOR LIGHT TRUCK	Drive Line	2 WHL L/H FRONT DRIVE
Production Date	11-Jan-2001	Retail Sale Indicator Code	
Plant Description	KANSAS CITY PLANT BUILD	Reaquired Vehicle	
Build Region		Warranty Start Date	15-Feb-2001
Build Country Code		Transmission Serial Number	
Mileage	0	Vehicle Axle Ratio	
Vehicle Restraint Code			

Disclaimer:

This data is for use as one of several potential "awareness" indicators for the Ford Motor Co. Enhanced Concern Identification System. It is unverified, draft, summary data generated from a computer "word search" of customer and technician symptom comments. Supplier data, technician and customer comments are unverified and actual root cause of any potential issue is not established by this summary.

PE12-019

MADZA

9/6/2012

APPENDIX 3 SUBJECT
VEHICLES

Consumer Reports

VOQ Mazda

ECI

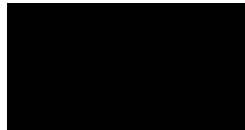



Concern Driven Reporting

Report Detail

Note: Field which are grayed (ghosted) are currently being mapped to the data warehouse. They are not presently being populated.

ECI Record		Source Code	VOQ Mazda
------------	--	-------------	-----------

Commodity Assignment

Commodity	powertrain-engine-accel pedal/linkage/controls	Symptom	contaminated/foreign
Commodity	powertrain-engine-accel pedal/linkage/controls	Symptom	pedal concerns-accelerator pedal
Commodity	powertrain-engine-accel pedal/linkage/controls	Symptom	sticks/binds/grabs
Commodity	powertrain-engine-accel pedal/linkage/controls	Symptom	unintended acceleration
Significant Event		Verified	N

Tread Information

Report Details

Source Claim Key	ODI 10047269	Warranty Component Classification (WCC)	
Corporate Product Systems Classification (CPSC)		Time in Service	
Customer Condition Code		V Function Group (VFG)	
Source System Program Type		Repair/Report/Paid Date	17-Nov-2003
Version Series Code	AAAA5	Load Date	01-Apr-2004
Causal Part Prefix-Base-Suffix	-	Dealer Code	
Causal Part Name	NOT PROVIDED BY SOURCE	Dealer Name	NOT PROVIDED BY SOURCE
Non Causal Part Prefix-Base-Suffix		Dealer City	
Non Causal Part Numbers		Dealer State/Province	
Fault Code		Dealer Country	USA
Diagonstic Trouble Code		Dealer Phone Number	
Labor Operation Code		Attachment	
Communication Type		VOQ Component Description Code	
Maintenance Date	01-Apr-2004		

Customer Comment	ACCELERATOR PEDAL IS STICKY RIGHT FROM THE START OF DEPRESSING THE PEDAL. ONCE THE RESISTANCE IS OVERCOME THE VEHICLE LURCHES FORWARD. DEALER CLAIMS CARBON BUILD UP (CONTAMINATION) ON OR NEAR THE THROTTLE PLATE IS CAUSING INITIAL RESISTANCE. TWO OCCURRENCES (APPROXIMATELY 5,000 AND 10,000 MILES) HAVE RESULTED IN DEALER CLEANING AREA TO REMOVE CONTAMINATION. *LA		
Technician Comment			
CQIS Recommendations			

Tire Information

Tire Manufacturer	Unknown	Tire Size	Unknown
Tire Brand Series		Wheel	
DOT Left Front		DOT Right Front	
DOT Left Rear		DOT Right Rear	
DOT Left Inner		DOT Right Inner	
DOT Spare			

Vehicle Information

VIN	4F2CZ04113K	Engine Serial Number	
Model Year	2003	Engine Description	3.0L DOHC EGI V6 NA *G DSP2967
Transmission	4 SPD AUTO TRANS MAZDA CD4E	Vehicle Description	TRIBUTE
Body Cab Style	CA WE 5 DOOR LIGHT TRUCK	Drive Line	2 WHL L/H FRONT DRIVE
Production Date	15-Oct-2002	Retail Sale Indicator Code	
Plant Description	KANSAS CITY PLANT BUILD	Reaquired Vehicle	
Build Region		Warranty Start Date	30-Dec-2002
Build Country Code		Transmission Serial Number	
Mileage	10500	Vehicle Axle Ratio	
Vehicle Restraint Code			

Disclaimer:

This data is for use as one of several potential "awareness" indicators for the Ford Motor Co. Enhanced Concern Identification System. It is unverified, draft, summary data generated from a computer "word search" of customer and technician symptom comments. Supplier data, technician and customer comments are unverified and actual root cause of any potential issue is not established by this summary.

[Contact ODRHELP](#)

Copyright 2001 Ford Motor Co All Rights Reserved

PE12-019

MADZA

9/6/2012

APPENDIX 3 SUBJECT
VEHICLES

Consumer Reports

VOQ Mazda

ECI

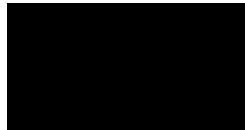



Concern Driven Reporting

Report Detail

Note: Field which are grayed (ghosted) are currently being mapped to the data warehouse. They are not presently being populated.

ECI Record		Source Code	VOQ Mazda
------------	--	-------------	-----------

Commodity Assignment			
Commodity	powertrain-engine-accel pedal/linkage/controls	Symptom	function-malfunction/inoperative
Commodity	powertrain-engine-accel pedal/linkage/controls	Symptom	high effort
Commodity	powertrain-engine-accel pedal/linkage/controls	Symptom	pedal concerns-accelerator pedal
Commodity	powertrain-engine-accel pedal/linkage/controls	Symptom	pedal concerns-pedal positions
Commodity	powertrain-engine-accel pedal/linkage/controls	Symptom	sticks/binds/grabs
Significant Event		Verified	N

Tread Information

Report Details

Source Claim Key		ODI I0053779	Warranty Component Classification (WCC)	
Corporate Product Systems Classification (CPS)			Time in Service	
Customer Condition Code			V Function Group (VFG)	
Source System Program Type			Repair/Report/Paid Date	01-Nov-2003
Version Series Code	AAAA5		Load Date	01-Apr-2004
Causal Part Prefix-Base-Suffix	-		Dealer Code	
Causal Part Name	NOT PROVIDED BY SOURCE		Dealer Name	NOT PROVIDED BY SOURCE
Non Causal Part Prefix-Base-Suffix			Dealer City	
Non Causal Part Numbers			Dealer State/Province	
Fault Code			Dealer Country	USA
Diagnostic Trouble Code			Dealer Phone Number	
Labor Operation Code			Attachment	
Communication Type			VOQ Component Description Code	
Maintenance Date	01-Apr-2004			

Customer Comment	THE ACCELERATOR PEDAL STUCK ON TWO SEPARATE OCCASIONS. THIS OCCURRED WHILE ACCELERATING FROM A STOP POSITION. AS A RESULT, EXCESSIVE FORCE HAD TO BE APPLIED TO THE PEDAL WHICH RESULTED IN RAPID ACCELERATION. BOTH FAILURES WERE DUE TO THE THROTTLE BODY.*AK *MR		
Technician Comment			
CQIS Recommendations			

Tire Information

Tire Manufacturer	Unknown	Tire Size	Unknown
Tire Brand Series		Wheel	
DOT Left Front		DOT Right Front	
DOT Left Rear		DOT Right Rear	
DOT Left Inner		DOT Right Inner	
DOT Spare			

Vehicle Information

VIN	4F2CU08101K	Engine Serial Number	003614087
Model Year	2001	Engine Description	3.0L DOHC EGI V6 NA*GAS
Transmission	4 SPD AUTO TRANS MAZDA CD4E	Vehicle Description	TRIBUTE
Body Cab Style	CA WE 5 DOOR LIGHT TRUCK	Drive Line	4 WHL L/H PART TIME DRIVE
Production Date	26-Jul-2001	Retail Sale Indicator Code	
Plant Description	KANSAS CITY PLANT BUILD	Required Vehicle	
Build Region		Warranty Start Date	06-Oct-2001
Build Country Code		Transmission Serial Number	
Mileage	20000	Vehicle Axle Ratio	
Vehicle Restraint Code			

Disclaimer:

This data is for use as one of several potential "awareness" indicators for the Ford Motor Co. Enhanced Concern Identification System. It is unverified, draft, summary data generated from a computer "word search" of customer and technician symptom comments. Supplier data, technician and customer comments are unverified and actual root cause of any potential issue is not established by this summary.

[Contact ODRHELP](#)

Copyright 2001 Ford Motor Co All Rights Reserved

PE12-019

MADZA

9/6/2012

APPENDIX 3 SUBJECT
VEHICLES

Consumer Reports

VOQ Mazda

ECI

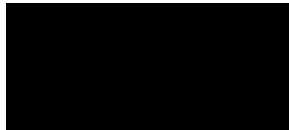



Concern Driven Reporting

Report Detail

Note: Field which are grayed (ghosted) are currently being mapped to the data warehouse. They are not presently being populated.

ECI Record		Source Code	VOQ Mazda
------------	--	-------------	-----------

Commodity Assignment

Commodity	powertrain-engine-accel pedal/linkage/controls	Symptom	engine power-loss of power
Commodity	powertrain-engine-accel pedal/linkage/controls	Symptom	function-malfunction/inoperative
Commodity	powertrain-engine-accel pedal/linkage/controls	Symptom	mod-driving condition-in neutral
Commodity	powertrain-engine-accel pedal/linkage/controls	Symptom	mod-driving condition-while driving
Commodity	powertrain-engine-accel pedal/linkage/controls	Symptom	mod-location-interior
Significant Event		Verified	N

Tread Information

Report Details

Source Claim Key		ODI 762592	Warranty Component Classification (WCC)	
Corporate Product Systems Classification (CPS)			Time in Service	
Customer Condition Code			V Function Group (VFG)	
Source System Program Type			Repair/Report/Paid Date	01-Jun-2002
Version Series Code	UNKN		Load Date	01-Apr-2005
Causal Part Prefix- Base - Suffix	- -		Dealer Code	
Causal Part Name	NOT PROVIDED BY SOURCE		Dealer Name	NOT PROVIDED BY SOURCE
Non Causal Part Prefix-Base-Suffix			Dealer City	
Non Causal Part Numbers			Dealer State/Province	
Fault Code			Dealer Country	USA
Diagnostic Trouble Code			Dealer Phone Number	
Labor Operation Code			Attachment	
Communication Type			VOQ Component Description Code	
Maintenance Date	01-Apr-2005			

Customer Comment	MAY 23, 2002 CRUISE CONTROL STOPPED WORKING. LIGHT ON CONSOLE COMES ON BUT DOESN'T ENGAGE. JUNE 01, 2002 LOST ALL POWER WHILE GOING APPROX 35 MPH AROUND A SLIGHT CURVE. PULLED TO THE SIDE, PUT IN NEUTRAL AND STARTED AGAIN.		
Technician Comment			
CQIS Recommendations			

Tire Information

Tire Manufacturer	Unknown	Tire Size	Unknown
Tire Brand Series		Wheel	
DOT Left Front		DOT Right Front	
DOT Left Rear		DOT Right Rear	
DOT Left Inner		DOT Right Inner	
DOT Spare			

Vehicle Information

VIN	UNK TRIBUTE	Engine Serial Number	UNKNOWN
Model Year	2001	Engine Description	Unknown
Transmission	Unknown	Vehicle Description	TRIBUTE
Body Cab Style	UNKN Unknown	Drive Line	Unknown
Production Date		Retail Sale Indicator Code	
Plant Description	Unknown	Required Vehicle	
Build Region		Warranty Start Date	
Build Country Code		Transmission Serial Number	UNKNOWN
Mileage	0	Vehicle Axle Ratio	
Vehicle Restraint Code			

Disclaimer:

This data is for use as one of several potential "awareness" indicators for the Ford Motor Co. Enhanced Concern Identification System. It is unverified, draft, summary data generated from a computer "word search" of customer and technician symptom comments. Supplier data, technician and customer comments are unverified and actual root cause of any potential issue is not established by this summary.

[Contact ODRHELP](#)

Copyright 2001 Ford Motor Co All Rights Reserved

PE12-019

MADZA

9/6/2012

APPENDIX 3 SUBJECT
VEHICLES

Consumer Reports

VOQ Mazda

ECI 



Concern Driven Reporting

Report Detail

Note: Field which are grayed (ghosted) are currently being mapped to the data warehouse. They are not presently being populated.

ECI Record		Source Code	VOQ Mazda
------------	--	-------------	-----------

Commodity Assignment

Commodity	powertrain-engine-accel pedal/linkage/controls	Symptom	pedal concerns-accelerator pedal
Significant Event	Property Damage;	Verified	N

Tread Information

Report Details

Source Claim Key	ODI 10015759	Warranty Component Classification (WCC)	
Corporate Product Systems Classification (CPSC)		Time in Service	
Customer Condition Code		V Function Group (VFG)	
Source System Program Type		Repair/Report/Paid Date	11-Apr-2003
Version Series Code	UNKN	Load Date	01-Apr-2005
Causal Part Prefix-Base-Suffix	-	Dealer Code	
Causal Part Name	NOT PROVIDED BY SOURCE	Dealer Name	NOT PROVIDED BY SOURCE
Non Causal Part Prefix-Base-Suffix		Dealer City	
Non Causal Part Numbers		Dealer State/Province	
Fault Code		Dealer Country	USA
Diagonstic Trouble Code		Dealer Phone Number	
Labor Operation Code		Attachment	
Communication Type		VOQ Component Description Code	
Maintenance Date	01-Apr-2005		

Customer Comment	THE CONSUMER PUT THE GEAR SHIFT IN THE DRIVE GEAR. WHEN THE DRIVER TAPPED THE ACCELERATOR PEDAL THE VEHICLE ACCELERATED IN FULL THROTTLE. *NLM *TS
------------------	--

Technician Comment

C Q I S Recommendations

Tire Information

Tire Manufacturer	Unknown	Tire Size	Unknown
Tire Brand Series		Wheel	
DOT Left Front		DOT Right Front	
DOT Left Rear		DOT Right Rear	
DOT Left Inner		DOT Right Inner	
DOT Spare			

Vehicle Information

VIN	UNK TRIBUTE	Engine Serial Number	UNKNOWN
Model Year	2001	Engine Description	Unknown
Transmission	Unknown	Vehicle Description	TRIBUTE
Body Cab Style	UNKN Unknown	Drive Line	Unknown
Production Date		Retail Sale Indicator Code	
Plant Description	Unknown	Reaquired Vehicle	
Build Region		Warranty Start Date	
Build Country Code		Transmission Serial Number	UNKNOWN
Mileage	29000	Vehicle Axle Ratio	
Vehicle Restraint Code			

Disclaimer:

This data is for use as one of several potential "awareness" indicators for the Ford Motor Co. Enhanced Concern Identification System. It is unverified, draft, summary data generated from a computer "word search" of customer and technician symptom comments. Supplier data, technician and customer comments are unverified and actual root cause of any potential issue is not established by this summary.

[Contact CDR HELP](#)

Copyright 2001 Ford Motor Co All Rights Reserved

PE12-019

MADZA

9/6/2012

APPENDIX 3 SUBJECT
VEHICLES

Consumer Reports

VOQ Mazda

ECI

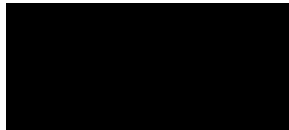



Concern Driven Reporting

Report Detail

Note: Field which are grayed (ghosted) are currently being mapped to the data warehouse. They are not presently being populated.

ECI Record		Source Code	VOQ Mazda
------------	--	-------------	-----------

Commodity Assignment

Commodity	powertrain-engine-accel pedal/linkage/controls	Symptom	function-malfunction/inoperative
Commodity	powertrain-engine-accel pedal/linkage/controls	Symptom	mod-driving condition-on acceleration
Commodity	powertrain-engine-accel pedal/linkage/controls	Symptom	mod-driving condition-while driving
Commodity	powertrain-engine-accel pedal/linkage/controls	Symptom	sticks/binds/grabs
Significant Event		Verified	N

Tread Information

Report Details

Source Claim Key	ODI 10010623	Warranty Component Classification (WCC)	
Corporate Product Systems Classification (CPSC)		Time in Service	
Customer Condition Code		V Function Group (VFG)	
Source System Program Type		Repair/Report/Paid Date	12-Feb-2003
Version Series Code	UNKN	Load Date	01-Apr-2005
Causal Part Prefix- Base - Suffix	- -	Dealer Code	
Causal Part Name	NOT PROVIDED BY SOURCE	Dealer Name	NOT PROVIDED BY SOURCE
Non Causal Part Prefix-Base-Suffix		Dealer City	
Non Causal Part Numbers		Dealer State/Province	
Fault Code		Dealer Country	USA
Diagonstic Trouble Code		Dealer Phone Number	
Labor Operation Code		Attachment	
Communication Type		VOQ Component Description Code	
Maintenance Date	01-Apr-2005		

Customer Comment	THROTTLE STICKS WHEN ACCELERATING FROM COMPLETE STOP DUE TO BUILD UP ON THROTTLE PLATE. OWNER HAS PROVIDED MAINTENANCE AND FUEL AS SPECIFIED IN MANUAL, YET WAS TOLD MAZDA DOES NOT COVER UNDER WARRANTY. PROBLEM APPEARED WITH LESS THAN 15000 MILES. CLEANING (AT OWNER COST) PROVIDES ONLY SHORT TERM REMEDY. *NLM		
Technician Comment			
CQIS Recommendations			

Tire Information

Tire Manufacturer	Unknown	Tire Size	Unknown
Tire Brand Series		Wheel	
DOT Left Front		DOT Right Front	
DOT Left Rear		DOT Right Rear	
DOT Left Inner		DOT Right Inner	
DOT Spare			

Vehicle Information

VIN	UNK TRIBUTE	Engine Serial Number	UNKNOWN
Model Year	2002	Engine Description	Unknown
Transmission	Unknown	Vehicle Description	TRIBUTE
Body Cab Style	UNKN Unknown	Drive Line	Unknown
Production Date		Retail Sale Indicator Code	
Plant Description	Unknown	Reaquired Vehicle	
Build Region		Warranty Start Date	
Build Country Code		Transmission Serial Number	UNKNOWN
Mileage	0	Vehicle Axle Ratio	
Vehicle Restraint Code			

Disclaimer:

This data is for use as one of several potential "awareness" indicators for the Ford Motor Co. Enhanced Concern Identification System. It is unverified, draft, summary data generated from a computer "word search" of customer and technician symptom comments. Supplier data, technician and customer comments are unverified and actual root cause of any potential issue is not established by this summary.

[Contact ODRHELP](#)

Copyright 2001 Ford Motor Co All Rights Reserved

PE12-019

MADZA

9/6/2012

APPENDIX 3 SUBJECT
VEHICLES

Consumer Reports

VOQ Mazda

ECI

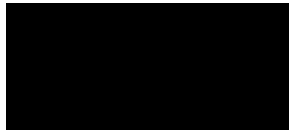



Concern Driven Reporting

Report Detail

Note: Field which are grayed (ghosted) are currently being mapped to the data warehouse. They are not presently being populated.

ECI Record		Source Code	VOQ Mazda
------------	--	-------------	-----------

Commodity Assignment

Commodity	powertrain-engine-accel pedal/linkage/controls	Symptom	engine power-hesitates
Commodity	powertrain-engine-accel pedal/linkage/controls	Symptom	mod-no indication (sudden)
Commodity	powertrain-engine-accel pedal/linkage/controls	Symptom	pedal concerns-accelerator pedal
Commodity	powertrain-engine-accel pedal/linkage/controls	Symptom	unintended acceleration
Significant Event		Verified	N

Tread Information

Report Details

Source Claim Key	ODI 10027270	Warranty Component Classification (WCC)	
Corporate Product Systems Classification (CPSC)		Time in Service	
Customer Condition Code		V Function Group (VFG)	
Source System Program Type		Repair/Report/Paid Date	14-Jul-2003
Version Series Code	UNKN	Load Date	01-Apr-2005
Causal Part Prefix-Base-Suffix	-	Dealer Code	
Causal Part Name	NOT PROVIDED BY SOURCE	Dealer Name	NOT PROVIDED BY SOURCE
Non Causal Part Prefix-Base-Suffix		Dealer City	
Non Causal Part Numbers		Dealer State/Province	
Fault Code		Dealer Country	USA
Diagonstic Trouble Code		Dealer Phone Number	
Labor Operation Code		Attachment	
Communication Type		VOQ Component Description Code	
Maintenance Date	01-Apr-2005		

Customer Comment	CONSUMER DEPRESSED ACCELERATOR PEDAL AND VEHICLE HESITATED, AND THEN SUDDENLY LURCHED FORWARD, ALMOST CAUSING A COLLISION. RELATED INVESTIGATION EA 02 027.*AK		
Technician Comment			
C Q I S Recommendations			

Tire Information

Tire Manufacturer	Unknown	Tire Size	Unknown
Tire Brand Series		Wheel	
DOT Left Front		DOT Right Front	
DOT Left Rear		DOT Right Rear	
DOT Left Inner		DOT Right Inner	
DOT Spare			

Vehicle Information

VIN	UNK TRIBUTE	Engine Serial Number	UNKNOWN
Model Year	2001	Engine Description	Unknown
Transmission	Unknown	Vehicle Description	TRIBUTE
Body Cab Style	UNKN Unknown	Drive Line	Unknown
Production Date		Retail Sale Indicator Code	
Plant Description	Unknown	Reaquired Vehicle	
Build Region		Warranty Start Date	
Build Country Code		Transmission Serial Number	UNKNOWN
Mileage	0	Vehicle Axle Ratio	
Vehicle Restraint Code			

Disclaimer:

This data is for use as one of several potential "awareness" indicators for the Ford Motor Co. Enhanced Concern Identification System. It is unverified, draft, summary data generated from a computer "word search" of customer and technician symptom comments. Supplier data, technician and customer comments are unverified and actual root cause of any potential issue is not established by this summary.

PE12-019

MADZA

9/6/2012

APPENDIX 3 SUBJECT
VEHICLES

Consumer Reports

VOQ Mazda

ECI

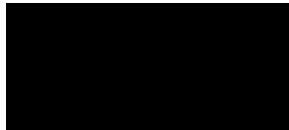



Concern Driven Reporting

Report Detail

Note: Field which are grayed (ghosted) are currently being mapped to the data warehouse. They are not presently being populated.

ECI Record		Source Code	VOQ Mazda
------------	--	-------------	-----------

Commodity Assignment

Commodity	powertrain-engine-accel pedal/linkage/controls	Symptom	function-malfunction/inoperative
Commodity	powertrain-engine-accel pedal/linkage/controls	Symptom	high effort
Commodity	powertrain-engine-accel pedal/linkage/controls	Symptom	pedal concerns-accelerator pedal
Commodity	powertrain-engine-accel pedal/linkage/controls	Symptom	pedal concerns-pedal positions
Commodity	powertrain-engine-accel pedal/linkage/controls	Symptom	sticks/binds/grabs
Significant Event		Verified	N

Tread Information

Report Details

Source Claim Key		ODI I0053779	Warranty Component Classification (WCC)	
Corporate Product Systems Classification (CPS)			Time in Service	
Customer Condition Code			V Function Group (VFG)	
Source System Program Type			Repair/Report/Paid Date	01-Nov-2003
Version Series Code	UNKN		Load Date	01-Apr-2005
Causal Part Prefix-Base-Suffix	-		Dealer Code	
Causal Part Name	NOT PROVIDED BY SOURCE		Dealer Name	NOT PROVIDED BY SOURCE
Non Causal Part Prefix-Base-Suffix			Dealer City	
Non Causal Part Numbers			Dealer State/Province	
Fault Code			Dealer Country	USA
Diagnostic Trouble Code			Dealer Phone Number	
Labor Operation Code			Attachment	
Communication Type			VOQ Component Description Code	
Maintenance Date	01-Apr-2005			

Customer Comment	THE ACCELERATOR PEDAL STUCK ON TWO SEPARATE OCCASIONS. THIS OCCURRED WHILE ACCELERATING FROM A STOP POSITION. AS A RESULT, EXCESSIVE FORCE HAD TO BE APPLIED TO THE PEDAL WHICH RESULTED IN RAPID ACCELERATION. BOTH FAILURES WERE DUE TO THE THROTTLE BODY.*AK *MR
Technician Comment	
CQIS Recommendations	

Tire Information

Tire Manufacturer	Unknown	Tire Size	Unknown
Tire Brand Series		Wheel	
DOT Left Front		DOT Right Front	
DOT Left Rear		DOT Right Rear	
DOT Left Inner		DOT Right Inner	
DOT Spare			

Vehicle Information

VIN	UNK TRIBUTE	Engine Serial Number	UNKNOWN
Model Year	2001	Engine Description	Unknown
Transmission	Unknown	Vehicle Description	TRIBUTE
Body Cab Style	UNKN Unknown	Drive Line	Unknown
Production Date		Retail Sale Indicator Code	
Plant Description	Unknown	Required Vehicle	
Build Region		Warranty Start Date	
Build Country Code		Transmission Serial Number	UNKNOWN
Mileage	20000	Vehicle Axle Ratio	
Vehicle Restraint Code			

Disclaimer:

This data is for use as one of several potential "awareness" indicators for the Ford Motor Co. Enhanced Concern Identification System. It is unverified, draft, summary data generated from a computer "word search" of customer and technician symptom comments. Supplier data, technician and customer comments are unverified and actual root cause of any potential issue is not established by this summary.

[Contact ODRHELP](#)

Copyright 2001 Ford Motor Co All Rights Reserved

PE12-019

MADZA

9/6/2012

APPENDIX 3 SUBJECT
VEHICLES

Consumer Reports

VOQ Mazda

ECI

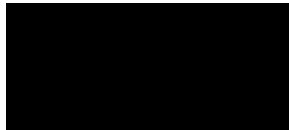



Concern Driven Reporting

Report Detail

Note: Field which are grayed (ghosted) are currently being mapped to the data warehouse. They are not presently being populated.

ECI Record		Source Code	VOQ Mazda
------------	--	-------------	-----------

Commodity Assignment			
Commodity	powertrain-engine-accel pedal/linkage/controls	Symptom	mod-driving condition-at cruise
Commodity	powertrain-engine-accel pedal/linkage/controls	Symptom	mod-driving condition-on acceleration
Commodity	powertrain-engine-accel pedal/linkage/controls	Symptom	mod-driving condition-while driving
Commodity	powertrain-engine-accel pedal/linkage/controls	Symptom	unintended acceleration
Significant Event	Personal Injury, Property Damage;	Verified	N

Tread Information

Report Details

Source Claim Key	ODI 10103702	Warranty Component Classification (WCC)	
Corporate Product Systems Classification (CPSC)		Time in Service	
Customer Condition Code		V Function Group (VFG)	
Source System Program Type		Repair/Report/Paid Date	23-Nov-2004
Version Series Code	UNKN	Load Date	01-Apr-2005
Causal Part Prefix- Base - Suffix	- -	Dealer Code	
Causal Part Name	NOT PROVIDED BY SOURCE	Dealer Name	NOT PROVIDED BY SOURCE
Non Causal Part Prefix-Base-Suffix		Dealer City	
Non Causal Part Numbers		Dealer State/Province	
Fault Code		Dealer Country	USA
Diagonstic Trouble Code		Dealer Phone Number	
Labor Operation Code		Attachment	
Communication Type		VOQ Component Description Code	
Maintenance Date	01-Apr-2005		

Customer Comment	WHILE BACKING OUT OF A PARKING SPACE THE BACK BUMPER SLIGHTLY BUMPED THE LIGHT POLE. WHEN THE CONSUMER SHIFTED THE VEHICLE INTO DRIVE IT COMMENCED TO ACCELERATE AT HIGH SPEED, LURCHED FORWARD AND RAN INTO A CENTER BLOCK WALL. NO INJURIES WERE REPORTED. THE INSURANCE COMPANY TOALED THE VEHICLE, AND THEY NOTIFIED THE DEALER AND THE MANUFACTURER *AK
Technician Comment	
CQIS Recommendations	

Tire Information

Tire Manufacturer	Unknown	Tire Size	Unknown
Tire Brand Series		Wheel	
DOT Left Front		DOT Right Front	
DOT Left Rear		DOT Right Rear	
DOT Left Inner		DOT Right Inner	
DOT Spare			

Vehicle Information

VIN	UNK TRIBUTE	Engine Serial Number	UNKNOWN
Model Year	2002	Engine Description	Unknown
Transmission	Unknown	Vehicle Description	TRIBUTE
Body Cab Style	UNKN Unknown	Drive Line	Unknown
Production Date		Retail Sale Indicator Code	
Plant Description	Unknown	Reaquired Vehicle	
Build Region		Warranty Start Date	
Build Country Code		Transmission Serial Number	UNKNOWN
Mileage	20000	Vehicle Axle Ratio	
Vehicle Restraint Code			

Disclaimer:

This data is for use as one of several potential "awareness" indicators for the Ford Motor Co. Enhanced Concern Identification System. It is unverified, draft, summary data generated from a computer "word search" of customer and technician symptom comments. Supplier data, technician and customer comments are unverified and actual root cause of any potential issue is not established by this summary.

[Contact ODRHELP](#)

Copyright 2001 Ford Motor Co All Rights Reserved

PE12-019

MADZA

9/6/2012

APPENDIX 3 SUBJECT
VEHICLES

Consumer Reports

VOQ Mazda

ECI

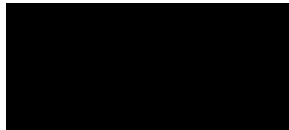



Concern Driven Reporting

Report Detail

Note: Field which are grayed (ghosted) are currently being mapped to the data warehouse. They are not presently being populated.

ECI Record		Source Code	VOQ Mazda
------------	--	-------------	-----------

Commodity Assignment			
Commodity	powertrain-engine-accel pedal/linkage/controls	Symptom	engine rpm surge/flare
Commodity	powertrain-engine-accel pedal/linkage/controls	Symptom	field service action
Commodity	powertrain-engine-accel pedal/linkage/controls	Symptom	high effort
Commodity	powertrain-engine-accel pedal/linkage/controls	Symptom	mod-driving condition-on acceleration
Commodity	powertrain-engine-accel pedal/linkage/controls	Symptom	mod-driving condition-while driving
Commodity	powertrain-engine-accel pedal/linkage/controls	Symptom	pedal concerns-accelerator pedal
Significant Event		Verified	N

Tread Information

Report Details

Source Claim Key	ODI 10114903	Warranty Component Classification (WCC)	
Corporate Product Systems Classification (CPSC)		Time in Service	
Customer Condition Code		V Function Group (VFG)	
Source System Program Type		Repair/Report/Paid Date	01-Mar-2005
Version Series Code	UNKN	Load Date	01-Apr-2005
Causal Part Prefix-Base-Suffix	-	Dealer Code	
Causal Part Name	NOT PROVIDED BY SOURCE	Dealer Name	NOT PROVIDED BY SOURCE
Non Causal Part Prefix-Base-Suffix		Dealer City	
Non Causal Part Numbers		Dealer State/Province	
Fault Code		Dealer Country	USA
Diagnostic Trouble Code		Dealer Phone Number	
Labor Operation Code		Attachment	
Communication Type		VOQ Component Description Code	
Maintenance Date	01-Apr-2005		

Customer Comment	THE CONSUMER NOTICED THAT THE GAS PEDAL ON HIS 2001 MAZDA TRIBUTE HAS BECOME HARDER TO DEPRESS AND THE ENGINE JUMPS WHEN THE VEHICLE ACCELERATES. *NM THE CONSUMER WANTS TO KNOW IF RECALL 04V574000 APPLIES TO HIS VEHICLE, BECAUSE A RECALL WAS ISSUED ON THE 2003 FORD ESCAPE AND FORD ALSO MADE THE MAZDA TRIBUTE. *SC *JB
Technician Comment	
CQIS Recommendations	

Tire Information

Tire Manufacturer	Unknown	Tire Size	Unknown
Tire Brand Series		Wheel	
DOT Left Front		DOT Right Front	
DOT Left Rear		DOT Right Rear	
DOT Left Inner		DOT Right Inner	
DOT Spare			

Vehicle Information

VIN	UNK TRIBUTE	Engine Serial Number	UNKNOWN
Model Year	2001	Engine Description	Unknown
Transmission	Unknown	Vehicle Description	TRIBUTE
Body Cab Style	UNKN Unknown	Drive Line	Unknown
Production Date		Retail Sale Indicator Code	
Plant Description	Unknown	Reaquired Vehicle	
Build Region		Warranty Start Date	
Build Country Code		Transmission Serial Number	UNKNOWN
Mileage	0	Vehicle Axle Ratio	
Vehicle Restraint Code			

Disclaimer:

This data is for use as one of several potential "awareness" indicators for the Ford Motor Co. Enhanced Concern Identification System. It is unverified, draft, summary data generated from a computer "word search" of customer and technician symptom comments. Supplier data, technician and customer comments are unverified and actual root cause of any potential issue is not established by this summary.

[Contact ODRHELP](#)

Copyright 2001 Ford Motor Co All Rights Reserved

PE12-019

MADZA

9/6/2012

APPENDIX 3 SUBJECT
VEHICLES

Consumer Reports

VOQ Mazda

ECI

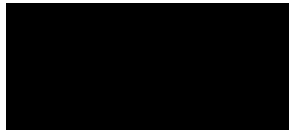



Concern Driven Reporting

Report Detail

Note: Field which are grayed (ghosted) are currently being mapped to the data warehouse. They are not presently being populated.

ECI Record		Source Code	VOQ Mazda
------------	--	-------------	-----------

Commodity Assignment			
Commodity	powertrain-engine-accel pedal/linkage/controls	Symptom	damage-cracked/fractured/split
Commodity	powertrain-engine-accel pedal/linkage/controls	Symptom	damage-cut/torn/frayed
Commodity	powertrain-engine-accel pedal/linkage/controls	Symptom	field service action
Commodity	powertrain-engine-accel pedal/linkage/controls	Symptom	function-malfunction/inoperative
Commodity	powertrain-engine-accel pedal/linkage/controls	Symptom	loss of control
Commodity	powertrain-engine-accel pedal/linkage/controls	Symptom	mod-vehicle towed in
Commodity	powertrain-engine-accel pedal/linkage/controls	Symptom	pedal concerns-accelerator pedal
Commodity	powertrain-engine-accel pedal/linkage/controls	Symptom	repair-prior repair mentioned
Commodity	powertrain-engine-accel pedal/linkage/controls	Symptom	separation
Significant Event	Personal Injury, Property Damage,	Verified	N

Tread Information

Report Details

Source Claim Key		ODI 10108769	Warranty Component Classification (WCC)	
Corporate Product Systems Classification (CPS)			Time in Service	
Customer Condition Code			V Function Group (VFG)	
Source System Program Type			Repair/Report/Paid Date	22-Jan-2005
Version Series Code	UNKN		Load Date	01-Apr-2005
Causal Part Prefix-Base-Suffix	-		Dealer Code	
Causal Part Name	NOT PROVIDED BY SOURCE		Dealer Name	NOT PROVIDED BY SOURCE
Non Causal Part Prefix-Base-Suffix			Dealer City	
Non Causal Part Numbers			Dealer State/Province	
Fault Code			Dealer Country	USA
Diagnostic Trouble Code			Dealer Phone Number	
Labor Operation Code			Attachment	
Communication Type			VOQ Component Description Code	
Maintenance Date	01-Apr-2005			

Customer Comment	NHTSA RECALL 04V583000 ON THE ACCELERATOR CABLE. APPROXIMATELY TWO YEARS AFTER HAVING THE ACCELERATOR CABLE REPLACED THE PROBLEM RECURRED. WHILE DRIVING 2 MPH, THE VEHICLE ACCELERATED UNCONTROLLABLY. THE DRIVER APPLIED THE BRAKE PEDAL AND THE VEHICLE CONTINUED TO ACCELERATE. THE DRIVER WAS NOT ABLE TO MAINTAIN THE CONTROL OF THE VEHICLE AND COLLIDED INTO A LIGHT POLE. THIS CAUSED THE DRIVER TO SUSTAIN MINOR INJURIES AND WAS TAKEN TO THE HOSPITAL. THE VEHICLE WAS TOWED TO A DEALER FOR INSPECTION. *JB THE BATTERY WAS INOPERATIVE DUE TO A BROKEN CABLE AND A FRAYED MAIN BELT HAD COME OFF AND THE STEERING WAS IMPAIRED. *SC		
Technician Comment			
CQIS Recommendations			

Tire Information

Tire Manufacturer	Unknown	Tire Size	Unknown
Tire Brand Series		Wheel	
DOT Left Front		DOT Right Front	
DOT Left Rear		DOT Right Rear	
DOT Left Inner		DOT Right Inner	
DOT Spare			

Vehicle Information

VIN	UNK TRIBUTE	Engine Serial Number	UNKNOWN
Model Year	2002	Engine Description	Unknown
Transmission	Unknown	Vehicle Description	TRIBUTE
Body Cab Style	UNKN Unknown	Drive Line	Unknown
Production Date		Retail Sale Indicator Code	
Plant Description	Unknown	Required Vehicle	
Build Region		Warranty Start Date	
Build Country Code		Transmission Serial Number	UNKNOWN
Mileage	27095	Vehicle Axle Ratio	
Vehicle Restraint Code			

Disclaimer:

This data is for use as one of several potential "awareness" indicators for the Ford Motor Co. Enhanced Concern Identification System. It is unverified, draft, summary data generated from a computer "word search" of customer and technician symptom comments. Supplier data, technician and customer comments are unverified and actual root cause of any potential issue is not established by this summary.

[Contact ODRHELP](#)

Copyright 2001 Ford Motor Co All Rights Reserved

PE12-019

MADZA

9/6/2012

APPENDIX 3 SUBJECT
VEHICLES

Consumer Reports

VOQ Mazda

ECI

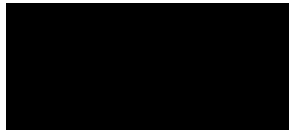



Concern Driven Reporting

Report Detail

Note: Field which are grayed (ghosted) are currently being mapped to the data warehouse. They are not presently being populated.

ECI Record		Source Code	VOQ Mazda
------------	--	-------------	-----------

Commodity Assignment

Commodity	powertrain-engine-accel pedal/linkage/controls	Symptom	function-malfunction/inoperative
Commodity	powertrain-engine-accel pedal/linkage/controls	Symptom	mod-driving condition-on deceleration/braking
Commodity	powertrain-engine-accel pedal/linkage/controls	Symptom	mod-driving condition-while driving
Commodity	powertrain-engine-accel pedal/linkage/controls	Symptom	mod-vehicle towed in
Commodity	powertrain-engine-accel pedal/linkage/controls	Symptom	sticks/binds/grabs
Significant Event		Verified	N

Tread Information

Report Details

Source Claim Key		ODI 10107624	Warranty Component Classification (WCC)	
Corporate Product Systems Classification (CPSC)			Time in Service	
Customer Condition Code			V Function Group (VFG)	
Source System Program Type			Repair/Report/Paid Date	17-Dec-2004
Version Series Code	UNKN		Load Date	05-May-2005
Causal Part Prefix- Base - Suffix	-		Dealer Code	
Causal Part Name	NOT PROVIDED BY SOURCE		Dealer Name	NOT PROVIDED BY SOURCE
Non Causal Part Prefix-Base-Suffix			Dealer City	
Non Causal Part Numbers			Dealer State/Province	
Fault Code			Dealer Country	USA
Diagnostic Trouble Code			Dealer Phone Number	
Labor Operation Code			Attachment	
Communication Type			VOQ Component Description Code	
Maintenance Date	05-May-2005			

Customer Comment	2005 MAZDA TRIBUTE [4000 MI] BRAKES FAILED AND THROTTLE STUCK ON DEC 17, 2004. I HAD TO PULL HAND BRAKE TO STOP CAR WAS TOWED TO DEALERSHIP IN AMHERST VA. THROTTLE ASSY, IDLE CONTROL VALVE AND A 100MI ROAD TEST WERE DONE. PICKED VEHICLE UP ON JAN 14,2005. ON JAN 15TH, PROBLEM OCCURRED AGAIN WITH BRAKES NON RESPONSIVE AND THROTTLE STUCK. SOMEONE ELSE WAS DRIVING AND THEY TURNED ENGINE OFF AND COASTED OFF THE ROAD. VEHICLE WAS TOWED BACK TO DEALERSHIP IN AMHERST AND REMAINS THERE AT PRESENT.		
Technician Comment			
CQIS Recommendations			

Tire Information

Tire Manufacturer	Unknown	Tire Size	Unknown
Tire Brand Series		Wheel	
DOT Left Front		DOT Right Front	
DOT Left Rear		DOT Right Rear	
DOT Left Inner		DOT Right Inner	
DOT Spare			

Vehicle Information

VIN	UNK TRIBUTE	Engine Serial Number	UNKNOWN
Model Year	2005	Engine Description	Unknown
Transmission	Unknown	Vehicle Description	TRIBUTE
Body Cab Style	UNKN Unknown	Drive Line	Unknown
Production Date		Retail Sale Indicator Code	
Plant Description	Unknown	Reaquired Vehicle	
Build Region		Warranty Start Date	
Build Country Code		Transmission Serial Number	UNKNOWN
Mileage	4000	Vehicle Axle Ratio	
Vehicle Restraint Code			

Disclaimer:

This data is for use as one of several potential "awareness" indicators for the Ford Motor Co. Enhanced Concern Identification System. It is unverified, draft, summary data generated from a computer "word search" of customer and technician symptom comments. Supplier data, technician and customer comments are unverified and actual root cause of any potential issue is not established by this summary.

[Contact ODRHELP](#)

Copyright 2001 Ford Motor Co All Rights Reserved

PE12-019

MADZA

9/6/2012

APPENDIX 3 SUBJECT
VEHICLES

Consumer Reports

VOQ Mazda

ECI

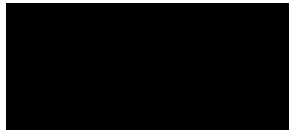



Concern Driven Reporting

Report Detail

Note: Field which are grayed (ghosted) are currently being mapped to the data warehouse. They are not presently being populated.

ECI Record		Source Code	VOQ Mazda
------------	--	-------------	-----------

Commodity Assignment

Commodity	powertrain-engine-accel pedal/linkage/controls—	Symptom	sticks/binds/grabs
Significant Event	Property Damage;	Verified	N

Tread Information

Report Details

Source Claim Key	ODI 10046790	Warranty Component Classification (WCC)	
Corporate Product Systems Classification (CPSC)		Time in Service	
Customer Condition Code		V Function Group (VFG)	
Source System Program Type		Repair/Report/Paid Date	11-Nov-2003
Version Series Code	UNKN	Load Date	11-May-2005
Causal Part Prefix- Base - Suffix	- -	Dealer Code	
Causal Part Name	NOT PROVIDED BY SOURCE	Dealer Name	NOT PROVIDED BY SOURCE
Non Causal Part Prefix-Base-Suffix		Dealer City	
Non Causal Part Numbers		Dealer State/Province	
Fault Code		Dealer Country	USA
Diagonstic Trouble Code		Dealer Phone Number	
Labor Operation Code		Attachment	
Communication Type		VOQ Component Description Code	
Maintenance Date	11-May-2005		

Customer Comment	ACCELERATOR PEDAL STUCK ON 2004 MAZDA TRIBUTE. *LA
Technician Comment	
CQIS Recommendations	

Tire Information

Tire Manufacturer	Unknown	Tire Size	Unknown
Tire Brand Series		Wheel	
DOT Left Front		DOT Right Front	
DOT Left Rear		DOT Right Rear	
DOT Left Inner		DOT Right Inner	
DOT Spare			

Vehicle Information

VIN	UNK TRIBUTE	Engine Serial Number	UNKNOWN
Model Year	2004	Engine Description	Unknown
Transmission	Unknown	Vehicle Description	TRIBUTE
Body Cab Style	UNKN Unknown	Drive Line	Unknown
Production Date		Retail Sale Indicator Code	
Plant Description	Unknown	Reaquired Vehicle	
Build Region		Warranty Start Date	
Build Country Code		Transmission Serial Number	UNKNOWN
Mileage	2200	Vehicle Axle Ratio	
Vehicle Restraint Code			

Disclaimer:

This data is for use as one of several potential "awareness" indicators for the Ford Motor Co. Enhanced Concern Identification System. It is unverified, draft, summary data generated from a computer "word search" of customer and technician symptom comments. Supplier data, technician and customer comments are unverified and actual root cause of any potential issue is not established by this summary.

PE12-019

MADZA

9/6/2012

APPENDIX 3 SUBJECT
VEHICLES

Consumer Reports

VOQ Mazda

ECI

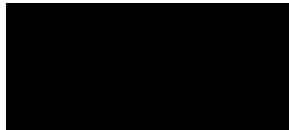



Concern Driven Reporting

Report Detail

Note: Field which are grayed (ghosted) are currently being mapped to the data warehouse. They are not presently being populated.

ECI Record		Source Code	VOQ Mazda
------------	--	-------------	-----------

Commodity Assignment

Commodity	powertrain-engine-accel pedal/linkage/controls	Symptom	damage
Commodity	powertrain-engine-accel pedal/linkage/controls	Symptom	engine rpm surge/flare
Commodity	powertrain-engine-accel pedal/linkage/controls	Symptom	unintended acceleration
Significant Event	Property Damage;	Verified	N

Tread Information

Report Details

Source Claim Key		ODI 10082337	Warranty Component Classification (WCC)	
Corporate Product Systems Classification (CPSC)			Time in Service	
Customer Condition Code			V Function Group (VFG)	
Source System Program Type			Repair/Report/Paid Date	07-May-2004
Version Series Code	UNKN		Load Date	11-May-2005
Causal Part Prefix- Base - Suffix	-		Dealer Code	
Causal Part Name	NOT PROVIDED BY SOURCE		Dealer Name	NOT PROVIDED BY SOURCE
Non Causal Part Prefix-Base-Suffix			Dealer City	
Non Causal Part Numbers			Dealer State/Province	
Fault Code			Dealer Country	USA
Diagnostic Trouble Code			Dealer Phone Number	
Labor Operation Code			Attachment	
Communication Type			VOQ Component Description Code	
Maintenance Date	11-May-2005			

Customer Comment	PULLING INTO A PARKING SPOT AND THE CAR SURGED FORWARD AT A HIGH RATE. RESULTING IN \$2,206.79 IN DAMAGE THE DEALER SAID THAT IS NOT POSSIBLE AND SAID THAT HAS NEVER HAPPENED BEFORE. *LA
Technician Comment	
CQIS Recommendations	

Tire Information

Tire Manufacturer	Unknown	Tire Size	Unknown
Tire Brand Series		Wheel	
DOT Left Front		DOT Right Front	
DOT Left Rear		DOT Right Rear	
DOT Left Inner		DOT Right Inner	
DOT Spare			

Vehicle Information

VIN	UNK TRIBUTE	Engine Serial Number	UNKNOWN
Model Year	2004	Engine Description	Unknown
Transmission	Unknown	Vehicle Description	TRIBUTE
Body Cab Style	UNKN Unknown	Drive Line	Unknown
Production Date		Retail Sale Indicator Code	
Plant Description	Unknown	Required Vehicle	
Build Region		Warranty Start Date	
Build Country Code		Transmission Serial Number	UNKNOWN
Mileage	5228	Vehicle Axle Ratio	
Vehicle Restraint Code			

Disclaimer:

This data is for use as one of several potential "awareness" indicators for the Ford Motor Co. Enhanced Concern Identification System. It is unverified, draft, summary data generated from a computer "word search" of customer and technician symptom comments. Supplier data, technician and customer comments are unverified and actual root cause of any potential issue is not established by this summary.

Contact ODR FILE

PE12-019

MADZA

9/6/2012

APPENDIX 3 SUBJECT
VEHICLES

Consumer Reports

VOQ Mazda

ECI

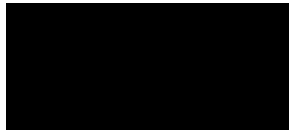



Concern Driven Reporting

Report Detail

Note: Field which are grayed (ghosted) are currently being mapped to the data warehouse. They are not presently being populated.

ECI Record		Source Code	VOQ Mazda
------------	--	-------------	-----------

Commodity Assignment			
Commodity	powertrain-engine-accel pedal/linkage/controls	Symptom	function-malfunction/inoperative
Commodity	powertrain-engine-accel pedal/linkage/controls	Symptom	loss of control
Commodity	powertrain-engine-accel pedal/linkage/controls	Symptom	mod-driving condition-at cruise
Commodity	powertrain-engine-accel pedal/linkage/controls	Symptom	mod-driving condition-on acceleration
Commodity	powertrain-engine-accel pedal/linkage/controls	Symptom	mod-driving condition-on deceleration/braking
Commodity	powertrain-engine-accel pedal/linkage/controls	Symptom	mod-driving condition-while driving
Commodity	powertrain-engine-accel pedal/linkage/controls	Symptom	mod-vehicle towed in
Commodity	powertrain-engine-accel pedal/linkage/controls	Symptom	no problem found
Significant Event		Verified	N

Tread Information

Report Details

Source Claim Key		ODI T0105214	Warranty Component Classification (WCC)	
Corporate Product Systems Classification (CPSC)			Time in Service	
Customer Condition Code			V Function Group (VFG)	
Source System Program Type			Repair/Report/Paid Date	21-Oct-2004
Version Series Code	UNKN		Load Date	11-May-2005
Causal Part Prefix- Base - Suffix	-		Dealer Code	
Causal Part Name	NOT PROVIDED BY SOURCE		Dealer Name	NOT PROVIDED BY SOURCE
Non Causal Part Prefix-Base-Suffix			Dealer City	
Non Causal Part Numbers			Dealer State/Province	
Fault Code			Dealer Country	USA
Diagnostic Trouble Code			Dealer Phone Number	
Labor Operation Code			Attachment	
Communication Type			VOQ Component Description Code	
Maintenance Date	11-May-2005			

Customer Comment	WHILE DRIVING 60 MPH OR MORE THE VEHICLE ACCELERATED UP TO 110 MPH FOR NO KNOWN REASON, THE CONSUMER STATED, SHE ATTEMPTED TO STOP THE VEHICLE BY APPLYING THE BRAKE, WHICH FAILED TO SLOW DOWN OR STOP THE VEHICLE. THE CONSUMER THEN PLACED THE VEHICLE INTO NEUTRAL, WHICH CAUSED THE VEHICLE TO FISH TAIL SEVERELY. THE CONSUMER SHIFTED THE VEHICLE BACK INTO DRIVE.A LITTLE WHILE LATER SHE SHIFTED THE VEHICLE INTO PARKED, WHICH CAUSED THE VEHICLE TO COME TO A COMPLETE STOP. THE VEHICLE WAS TOWED TO THE DEALER. THE DEALER INSPECTED THE VEHICLE AND COULD NOT FIND ANYTHING WRONG. *JB
Technician Comment	
CQIS Recommendations	

Tire Information

Tire Manufacturer	Unknown	Tire Size	Unknown
Tire Brand Series		Wheel	
DOT Left Front		DOT Right Front	
DOT Left Rear		DOT Right Rear	
DOT Left Inner		DOT Right Inner	
DOT Spare			

Vehicle Information

VIN	UNK TRIBUTE	Engine Serial Number	UNKNOWN
Model Year	2004	Engine Description	Unknown
Transmission	Unknown	Vehicle Description	TRIBUTE
Body Cab Style	UNKN Unknown	Drive Line	Unknown
Production Date		Retail Sale Indicator Code	
Plant Description	Unknown	Required Vehicle	
Build Region		Warranty Start Date	
Build Country Code		Transmission Serial Number	UNKNOWN
Mileage	10000	Vehicle Axle Ratio	
Vehicle Restraint Code			

Disclaimer:

This data is for use as one of several potential "awareness" indicators for the Ford Motor Co. Enhanced Concern Identification System. It is unverified, draft, summary data generated from a computer "word search" of customer and technician symptom comments. Supplier data, technician and customer comments are unverified and actual root cause of any potential issue is not established by this summary.

[Contact ODRHELP](#)

Copyright 2001 Ford Motor Co All Rights Reserved

PE12-019

MADZA

9/6/2012

APPENDIX 3 SUBJECT
VEHICLES

Consumer Reports

VOQ Mazda

ECI

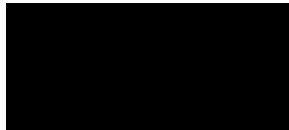



Concern Driven Reporting

Report Detail

Note: Field which are grayed (ghosted) are currently being mapped to the data warehouse. They are not presently being populated.

ECI Record		Source Code	VOQ Mazda
------------	--	-------------	-----------

Commodity Assignment			
Commodity	powertrain-engine-accel pedal/linkage/controls	Symptom	damage
Commodity	powertrain-engine-accel pedal/linkage/controls	Symptom	function-malfunction/inoperative
Commodity	powertrain-engine-accel pedal/linkage/controls	Symptom	function-stays on
Commodity	powertrain-engine-accel pedal/linkage/controls	Symptom	mod-driving condition-at cruise
Commodity	powertrain-engine-accel pedal/linkage/controls	Symptom	mod-driving condition-on acceleration
Commodity	powertrain-engine-accel pedal/linkage/controls	Symptom	mod-driving condition-while driving
Commodity	powertrain-engine-accel pedal/linkage/controls	Symptom	mod-no indication (sudden)
Significant Event		Verified	N

Tread Information

Report Details

Source Claim Key	ODI 10119300	Warranty Component Classification (WCC)	
Corporate Product Systems Classification (CPSC)		Time in Service	
Customer Condition Code		V Function Group (VFG)	
Source System Program Type		Repair/Report/Paid Date	01-Apr-2005
Version Series Code	UNKN	Load Date	23-May-2005
Causal Part Prefix- Base - Suffix	- -	Dealer Code	
Causal Part Name	NOT PROVIDED BY SOURCE	Dealer Name	NOT PROVIDED BY SOURCE
Non Causal Part Prefix-Base-Suffix		Dealer City	
Non Causal Part Numbers		Dealer State/Province	
Fault Code		Dealer Country	USA
Diagonstic Trouble Code		Dealer Phone Number	
Labor Operation Code		Attachment	
Communication Type		VOQ Component Description Code	
Maintenance Date	23-May-2005		

Customer Comment	2004 MAZDA TRIBUTE EXPERIENCING PROBLEMS WITH SUDDEN ACCELERATION. *MR THERE WERE TWO OCCASIONS WHEN THE CONSUMER APPLIED THE BRAKES BUT THE VEHICLE DID NOT STOP. ONE OCCASION THE VEHICLE WAS PULLING UP TO A BUILDING AND DAMAGED THE FRONT END OF THE VEHICLE AND ON THE SECOND OCCASION, THE CONSUMER WAS TRAVELING ON THE HIGHWAY WHEN THE VEHICLE SUDDENLY ACCELERATED WITHOUT INCIDENT. *SC		
Technician Comment			
CQIS Recommendations			

Tire Information

Tire Manufacturer	Unknown	Tire Size	Unknown
Tire Brand Series		Wheel	
DOT Left Front		DOT Right Front	
DOT Left Rear		DOT Right Rear	
DOT Left Inner		DOT Right Inner	
DOT Spare			

Vehicle Information

VIN	UNKN TRIBUTE	Engine Serial Number	UNKNOWN
Model Year	2004	Engine Description	Unknown
Transmission	Unknown	Vehicle Description	TRIBUTE
Body Cab Style	UNKN Unknown	Drive Line	Unknown
Production Date		Retail Sale Indicator Code	
Plant Description	Unknown	Reaquired Vehicle	
Build Region		Warranty Start Date	
Build Country Code		Transmission Serial Number	UNKNOWN
Mileage	0	Vehicle Axle Ratio	
Vehicle Restraint Code			

Disclaimer:

This data is for use as one of several potential "awareness" indicators for the Ford Motor Co. Enhanced Concern Identification System. It is unverified, draft, summary data generated from a computer "word search" of customer and technician symptom comments. Supplier data, technician and customer comments are unverified and actual root cause of any potential issue is not established by this summary.

[Contact ODRHELP](#)

Copyright 2001 Ford Motor Co All Rights Reserved

PE12-019

MADZA

9/6/2012

APPENDIX 3 SUBJECT
VEHICLES

Consumer Reports

VOQ Mazda

ECI

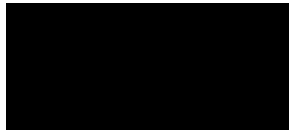



Concern Driven Reporting

Report Detail

Note: Field which are grayed (ghosted) are currently being mapped to the data warehouse. They are not presently being populated.

ECI Record		Source Code	VOQ Mazda
------------	--	-------------	-----------

Commodity Assignment			
Commodity	powertrain-engine-accel pedal/linkage/controls	Symptom	field service action
Commodity	powertrain-engine-accel pedal/linkage/controls	Symptom	mod-weather-cold
Commodity	powertrain-engine-accel pedal/linkage/controls	Symptom	no problem found
Commodity	powertrain-engine-accel pedal/linkage/controls	Symptom	pedal concerns-accelerator pedal
Commodity	powertrain-engine-accel pedal/linkage/controls	Symptom	sticks/binds/grabs
Significant Event	Property Damage;	Verified	N

Tread Information

Report Details

Source Claim Key		ODI 10119596	Warranty Component Classification (WCC)	
Corporate Product Systems Classification (CPSC)			Time in Service	
Customer Condition Code			V Function Group (VFG)	
Source System Program Type			Repair/Report/Paid Date	05-Dec-2003
Version Series Code		UNKN	Load Date	08-Jun-2005
Causal Part Prefix- Base - Suffix		-	Dealer Code	
Causal Part Name		NOT PROVIDED BY SOURCE	Dealer Name	NOT PROVIDED BY SOURCE
Non Causal Part Prefix-Base-Suffix			Dealer City	
Non Causal Part Numbers			Dealer State/Province	
Fault Code			Dealer Country	USA
Diagnostic Trouble Code			Dealer Phone Number	
Labor Operation Code			Attachment	
Communication Type			VOQ Component Description Code	
Maintenance Date		08-Jun-2005		

Customer Comment	CONTACT STATES THE ACCELERATOR IS STICKING. RECEIVED A RECALL LETTER, AND TOOK THE LETTER TO THE DEALER, WHO DID NOT FIX THE PROBLEM. ACCELERATOR STICKS MAINLY IN THE WINTER...WHEN TAKING FOOT OFF THE PEDAL FOR A FEW SECONDS AND TRYING TO HIT THE ACCELERATOR AGAIN VEHICLE SPEEDS UP AND IT JUMPS. *AK *JB		
Technician Comment			
CQIS Recommendations			

Tire Information

Tire Manufacturer	Unknown	Tire Size	Unknown
Tire Brand Series		Wheel	
DOT Left Front		DOT Right Front	
DOT Left Rear		DOT Right Rear	
DOT Left Inner		DOT Right Inner	
DOT Spare			

Vehicle Information

VIN	UNK TRIBUTE	Engine Serial Number	UNKNOWN
Model Year	2002	Engine Description	Unknown
Transmission	Unknown	Vehicle Description	TRIBUTE
Body Cab Style	UNKN Unknown	Drive Line	Unknown
Production Date		Retail Sale Indicator Code	
Plant Description	Unknown	Required Vehicle	
Build Region		Warranty Start Date	
Build Country Code		Transmission Serial Number	UNKNOWN
Mileage	6000	Vehicle Axle Ratio	
Vehicle Restraint Code			

Disclaimer:

This data is for use as one of several potential "awareness" indicators for the Ford Motor Co. Enhanced Concern Identification System. It is unverified, draft, summary data generated from a computer "word search" of customer and technician symptom comments. Supplier data, technician and customer comments are unverified and actual root cause of any potential issue is not established by this summary.

[Contact ODRHELP](#)

Copyright 2001 Ford Motor Co All Rights Reserved

PE12-019

MADZA

9/6/2012

APPENDIX 3 SUBJECT
VEHICLES

Consumer Reports

VOQ Mazda

ECI

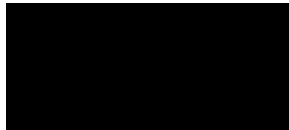



Concern Driven Reporting

Report Detail

Note: Field which are grayed (ghosted) are currently being mapped to the data warehouse. They are not presently being populated.

ECI Record		Source Code	VOQ Mazda
------------	--	-------------	-----------

Commodity Assignment			
Commodity	powertrain-engine-accel	pedal/linkage/controls	Symptom
			engine rpm surge/flare
Commodity	powertrain-engine-accel	pedal/linkage/controls	Symptom
			function-malfunction/inoperative
Commodity	powertrain-engine-accel	pedal/linkage/controls	Symptom
			function-stays on
Commodity	powertrain-engine-accel	pedal/linkage/controls	Symptom
			mod-driving condition-at idle
Commodity	powertrain-engine-accel	pedal/linkage/controls	Symptom
			mod-driving condition-on acceleration
Commodity	powertrain-engine-accel	pedal/linkage/controls	Symptom
			mod-driving condition-when engine running
Commodity	powertrain-engine-accel	pedal/linkage/controls	Symptom
			mod-driving condition-when engine/ignition turned off
Significant Event		Verified	N

Tread Information

Report Details

Source Claim Key		ODI 10125132	Warranty Component Classification (WCC)	
Corporate Product Systems Classification (CPSC)			Time in Service	
Customer Condition Code			V Function Group (VFG)	
Source System Program Type			Repair/Report/Paid Date	10-Jun-2005
Version Series Code	UNKN		Load Date	15-Jun-2005
Causal Part Prefix-Base-Suffix	-		Dealer Code	
Causal Part Name	NOT PROVIDED BY SOURCE		Dealer Name	NOT PROVIDED BY SOURCE
Non Causal Part Prefix-Base-Suffix			Dealer City	
Non Causal Part Numbers			Dealer State/Province	
Fault Code			Dealer Country	USA
Diagnostic Trouble Code			Dealer Phone Number	
Labor Operation Code			Attachment	
Communication Type			VOQ Component Description Code	
Maintenance Date	15-Jun-2005			

Customer Comment OCCASIONALLY, WHILE MY CAR IS IDLE BOTH PARKED BUT RUNNING OR WHILE I'M IN TRAFFIC, THE ENGINE ACCELERATES AND THE RPM GAUGE RACES. THE ENGINE WILL NOT STOP RACING UNLESS I TURN THE CAR OFF. ALSO, DRIVER CAR DOOR DOES NOT OPEN FROM THE INSIDE, SERVICE DEALER SAYS I NEED TO REPLACE ENTIRE LOCK INCLUDING COMPONENTS NOT COVERED UNDER MAP.

Technician Comment

CQIS Recommendations

Tire Information

Tire Manufacturer	Unknown	Tire Size	Unknown
Tire Brand Series		Wheel	
DOT Left Front		DOT Right Front	
DOT Left Rear		DOT Right Rear	
DOT Left Inner		DOT Right Inner	
DOT Spare			

Vehicle Information

VIN	UNK TRIBUTE	Engine Serial Number	UNKNOWN
Model Year	2001	Engine Description	Unknown
Transmission	Unknown	Vehicle Description	TRIBUTE
Body Cab Style	UNKN Unknown	Drive Line	Unknown
Production Date		Retail Sale Indicator Code	
Plant Description	Unknown	Reaquired Vehicle	
Build Region		Warranty Start Date	
Build Country Code		Transmission Serial Number	UNKNOWN
Mileage	0	Vehicle Axle Ratio	
Vehicle Restraint Code			

Disclaimer:

This data is for use as one of several potential "awareness" indicators for the Ford Motor Co. Enhanced Concern Identification System. It is unverified, draft, summary data generated from a computer "word search" of customer and technician symptom comments. Supplier data, technician and customer comments are unverified and actual root cause of any potential issue is not established by this summary.

[Contact ODRHELP](#)

Copyright 2001 Ford Motor Co All Rights Reserved

PE12-019

MADZA

9/6/2012

APPENDIX 3 SUBJECT
VEHICLES

Consumer Reports

VOQ Mazda

ECI

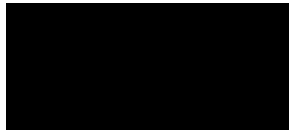



Concern Driven Reporting

Report Detail

Note: Field which are grayed (ghosted) are currently being mapped to the data warehouse. They are not presently being populated.

ECI Record		Source Code	VOQ Mazda
------------	--	-------------	-----------

Commodity Assignment			
Commodity	powertrain-engine-accel pedal/linkage/controls	Symptom	function-malfunction/inoperative
Commodity	powertrain-engine-accel pedal/linkage/controls	Symptom	loose
Commodity	powertrain-engine-accel pedal/linkage/controls	Symptom	pedal concerns-accelerator pedal
Significant Event		Verified	N

Tread Information

Report Details

Source Claim Key		ODI 10127870	Warranty Component Classification (WCC)	
Corporate Product Systems Classification (CPSC)			Time in Service	
Customer Condition Code			V Function Group (VFG)	
Source System Program Type			Repair/Report/Paid Date	08-Jul-2005
Version Series Code	UNKN		Load Date	13-Jul-2005
Causal Part Prefix- Base - Suffix	-		Dealer Code	
Causal Part Name	NOT PROVIDED BY SOURCE		Dealer Name	NOT PROVIDED BY SOURCE
Non Causal Part Prefix-Base-Suffix			Dealer City	
Non Causal Part Numbers			Dealer State/Province	
Fault Code			Dealer Country	USA
Diagnostic Trouble Code			Dealer Phone Number	
Labor Operation Code			Attachment	
Communication Type			VOQ Component Description Code	
Maintenance Date	13-Jul-2005			

Customer Comment	CONSUMER STATES SHE RECEIVED A RECALL LETTER NOTICE IN THE MAIL IN 1 05 REGARDING THE ACCELERATOR CABLE. THERE WAS NO RECALL # AVAILABLE. SHE TOOK IT IN TO A DEALER AND THEY EITHER REPLACED/OR REPAIRED THE CABLE, SHE WAS NOT SURE. SHE HAS NOTICED AN EXTREME CHANGE IN THE ACCELERATOR PEDAL SINCE THEN. THE GAS PEDAL SEEMS TO BE TO LOSE; SHE SAYS THERE SEEMS TO BE NO TENSION IN THE PEDAL. SHE TOOK IT BACK TO THE DEALER AND HE TOLD HER THAT WAS NORMAL; THAT THERE WAS A DIFFERENT CABLE IN THE CAR AND THAT WAS WHAT SHE WAS FEELING. SHE DOES NOT AGREE. SHE HAS NOT YET REPORTED THIS TO THE MANUFACTURER. SHE WANTS THE DEALER TO REPLACE THE CABLE THEY SAY THEY REPLACED.		
Technician Comment			
CQIS Recommendations			

Tire Information

Tire Manufacturer	Unknown	Tire Size	Unknown
Tire Brand Series		Wheel	
DOT Left Front		DOT Right Front	
DOT Left Rear		DOT Right Rear	
DOT Left Inner		DOT Right Inner	
DOT Spare			

Vehicle Information

VIN	UNK TRIBUTE	Engine Serial Number	UNKNOWN
Model Year	2002	Engine Description	Unknown
Transmission	Unknown	Vehicle Description	TRIBUTE
Body Cab Style	UNKN Unknown	Drive Line	Unknown
Production Date		Retail Sale Indicator Code	
Plant Description	Unknown	Reaquired Vehicle	
Build Region		Warranty Start Date	
Build Country Code		Transmission Serial Number	UNKNOWN
Mileage	0	Vehicle Axle Ratio	
Vehicle Restraint Code			

Disclaimer:

This data is for use as one of several potential "awareness" indicators for the Ford Motor Co. Enhanced Concern Identification System. It is unverified, draft, summary data generated from a computer "word search" of customer and technician symptom comments. Supplier data, technician and customer comments are unverified and actual root cause of any potential issue is not established by this summary.

[Contact ODRHELP](#)

Copyright 2001 Ford Motor Co All Rights Reserved

PE12-019

MADZA

9/6/2012

APPENDIX 3 SUBJECT
VEHICLES

Consumer Reports

VOQ Mazda

ECI

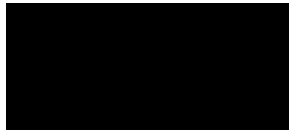



Concern Driven Reporting

Report Detail

Note: Field which are grayed (ghosted) are currently being mapped to the data warehouse. They are not presently being populated.

ECI Record		Source Code	VOQ Mazda
------------	--	-------------	-----------

Commodity Assignment			
Commodity	powertrain-engine-accel pedal/linkage/controls	Symptom	function-malfunction/inoperative
Commodity	powertrain-engine-accel pedal/linkage/controls	Symptom	function-stays on
Commodity	powertrain-engine-accel pedal/linkage/controls	Symptom	mod-driving condition-at cruise
Commodity	powertrain-engine-accel pedal/linkage/controls	Symptom	mod-driving condition-in neutral
Commodity	powertrain-engine-accel pedal/linkage/controls	Symptom	mod-intermittent/random
Commodity	powertrain-engine-accel pedal/linkage/controls	Symptom	mod-no indication (sudden)
Commodity	powertrain-engine-accel pedal/linkage/controls	Symptom	pedal concerns-accelerator pedal
Commodity	powertrain-engine-accel pedal/linkage/controls	Symptom	unintended acceleration
Significant Event		Verified	N

Tread Information

Report Details

Source Claim Key		ODI T0149101	Warranty Component Classification (WCC)	
Corporate Product Systems Classification (CPSC)			Time in Service	
Customer Condition Code			V Function Group (VFG)	
Source System Program Type			Repair/Report/Paid Date	26-Jan-2006
Version Series Code	UNKN		Load Date	15-Mar-2006
Causal Part Prefix- Base - Suffix	-		Dealer Code	
Causal Part Name	NOT PROVIDED BY SOURCE		Dealer Name	NOT PROVIDED BY SOURCE
Non Causal Part Prefix-Base-Suffix			Dealer City	
Non Causal Part Numbers			Dealer State/Province	
Fault Code			Dealer Country	USA
Diagnostic Trouble Code			Dealer Phone Number	
Labor Operation Code			Attachment	
Communication Type			VOQ Component Description Code	
Maintenance Date	29-Mar-2006			

Customer Comment	DT* THE CONTACT STATED WHILE THE CRUISE CONTROL IS ENGAGED, IF THE ACCELERATOR IS GENTLY APPLIED THE PEDAL PULLED DOWN TO THE FLOOR. THE VEHICLE SUDDENLY LURCHED FORWARD. THE CONTACT PULLED OVER AND PLACED THE VEHICLE IN NEUTRAL. WITH THE ACCELERATION SUBDUED, THE ENGINE WAS TURNED OFF AND ON, BUT THE ACCELERATOR PEDAL REMAINED ON THE FLOOR. THE VEHICLE WAS SEEN BY A DEALER, BUT THE DEALER WAS UNABLE TO DUPLICATE THE PROBLEM. THE VEHICLE WAS SEEN BY A SECONDARY DEALER. ALTHOUGH THE DEALER WAS UNABLE TO DUPLICATE THE PROBLEM AS WELL, THE DEALER REPLACED THE ACCELERATOR CABLE AND CRUISE CONTROL. THE VEHICLE HAS NOT BEEN DRIVEN TO DETERMINE IF THIS REPAIR REMEDIED THE PROBLEM.		
Technician Comment			
CQIS Recommendations			

Tire Information

Tire Manufacturer	Unknown	Tire Size	Unknown
Tire Brand Series		Wheel	
DOT Left Front		DOT Right Front	
DOT Left Rear		DOT Right Rear	
DOT Left Inner		DOT Right Inner	
DOT Spare			

Vehicle Information

VIN	*4F2CZ	Engine Serial Number	UNKNOWN
Model Year	2003	Engine Description	Unknown
Transmission	Unknown	Vehicle Description	TRIBUTE
Body Cab Style	UNKN Unknown	Drive Line	Unknown
Production Date		Retail Sale Indicator Code	
Plant Description	Unknown	Required Vehicle	
Build Region		Warranty Start Date	12-Mar-2006
Build Country Code		Transmission Serial Number	UNKNOWN
Mileage	61000	Vehicle Axle Ratio	
Vehicle Restraint Code			

Disclaimer:

This data is for use as one of several potential "awareness" indicators for the Ford Motor Co. Enhanced Concern Identification System. It is unverified, draft, summary data generated from a computer "word search" of customer and technician symptom comments. Supplier data, technician and customer comments are unverified and actual root cause of any potential issue is not established by this summary.

[Contact ODRHELP](#)

Copyright 2001 Ford Motor Co All Rights Reserved

PE12-019

MADZA

9/6/2012

APPENDIX 3 SUBJECT
VEHICLES

Consumer Reports

VOQ Mazda

ECI

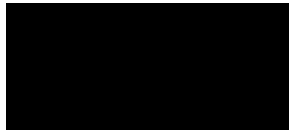



Concern Driven Reporting

Report Detail

Note: Field which are grayed (ghosted) are currently being mapped to the data warehouse. They are not presently being populated.

ECI Record		Source Code	VOQ Mazda
------------	--	-------------	-----------

Commodity Assignment

Commodity	powertrain-engine-accel pedal/linkage/controls	Symptom	function-malfunction/inoperative
Commodity	powertrain-engine-accel pedal/linkage/controls	Symptom	mod-no indication (sudden)
Commodity	powertrain-engine-accel pedal/linkage/controls	Symptom	pedal concerns-accelerator pedal
Commodity	powertrain-engine-accel pedal/linkage/controls	Symptom	pressure-low
Commodity	powertrain-engine-accel pedal/linkage/controls	Symptom	repair-prior repair mentioned
Commodity	powertrain-engine-accel pedal/linkage/controls	Symptom	repair-similar failures on other vehicles mentioned
Commodity	powertrain-engine-accel pedal/linkage/controls	Symptom	sticks/binds/grabs
Significant Event		Verified	Y

Tread Information

Report Details

Source Claim Key		ODI 10156904	Warranty Component Classification (WCC)	
Corporate Product Systems Classification (CPSC)			Time in Service	
Customer Condition Code			V Function Group (VFG)	
Source System Program Type			Repair/Report/Paid Date	05-May-2006
Version Series Code	UNKN		Load Date	11-May-2006
Causal Part Prefix- Base - Suffix	- -		Dealer Code	
Causal Part Name	NOT PROVIDED BY SOURCE		Dealer Name	NOT PROVIDED BY SOURCE
Non Causal Part Prefix-Base-Suffix			Dealer City	
Non Causal Part Numbers			Dealer State/Province	
Fault Code			Dealer Country	USA
Diagonstic Trouble Code			Dealer Phone Number	
Labor Operation Code			Attachment	
Communication Type			VOQ Component Description Code	
Maintenance Date	11-May-2006			

Customer Comment
 ACCELERATOR PEDAL BEGAN STICKING. I COULD NOT RAISE THE PEDAL UP OR PRESS IT DOWN. SUDDENLY, CAR WOULD TAKE OFF. THIS HAPPENS AT ANY TIME DURING DRIVING. I HAVE TAKEN THE CAR BACK TO DEALERSHIP TWICE FOR THE SAME PROBLEM. ALL WITHIN 6 MONTHS TIME. I FEEL THIS IS A SAFETY ISSUE WITH THE VEHICLE. I WAS TOLD IT WAS CARBON BUILD UP ON THE THROTTLE BODY. I FEEL IT IS AN ISSUE WITH THE TRIBUTE, OTHER CARS DO NOT HAVE THIS ISSUE. ALL THEY DID WAS CLEAN THE THROTTLE BODY BOTH TIMES. THEY ALSO SAID IT WAS NOT COVERED UNDER WARRANTY ALTHOUGH THEY DID NOT CHARGE ME FOR THE WORK DONE. I AM LEARY ABOUT DRIVING MY CAR SINCE I NEVER KNOW WHEN IT WILL START STICKING AGAIN. *JB

Technician Comment
CQIS Recommendation

Tire Information

Tire Manufacturer	Unknown	Tire Size	Unknown
Tire Brand Series		Wheel	
DOT Left Front		DOT Right Front	
DOT Left Rear		DOT Right Rear	
DOT Left Inner		DOT Right Inner	
DOT Spare			

Vehicle Information

VIN	*4F2YZ	Engine Serial Number	UNKNOWN
Model Year	2005	Engine Description	Unknown
Transmission	Unknown	Vehicle Description	TRIBUTE
Body Cab Style	UNKN Unknown	Drive Line	Unknown
Production Date		Retail Sale Indicator Code	
Plant Description	Unknown	Reaquired Vehicle	
Build Region		Warranty Start Date	
Build Country Code		Transmission Serial Number	UNKNOWN
Mileage	0	Vehicle Axle Ratio	
Vehicle Restraint Code			

Disclaimer:

This data is for use as one of several potential "awareness" indicators for the Ford Motor Co. Enhanced Concern Identification System. It is unverified, draft, summary data generated from a computer "word search" of customer and technician symptom comments. Supplier data, technician and customer comments are unverified and actual root cause of any potential issue is not established by this summary.

[Contact ODRHELP](#)

Copyright 2001 Ford Motor Co All Rights Reserved

PE12-019

MADZA

9/6/2012

APPENDIX 3 SUBJECT
VEHICLES

Consumer Reports

VOQ Mazda

ECI

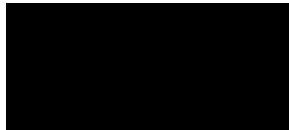



Concern Driven Reporting

Report Detail

Note: Field which are grayed (ghosted) are currently being mapped to the data warehouse. They are not presently being populated.

ECI Record		Source Code	VOQ Mazda
------------	--	-------------	-----------

Commodity Assignment

Commodity	powertrain-engine-accel pedal/linkage/controls	Symptom	damage-cracked/fractured/split
Commodity	powertrain-engine-accel pedal/linkage/controls	Symptom	function-malfunction/inoperative
Commodity	powertrain-engine-accel pedal/linkage/controls	Symptom	function-stays on
Commodity	powertrain-engine-accel pedal/linkage/controls	Symptom	leak-failed gasket/seal/weatherstrip
Commodity	powertrain-engine-accel pedal/linkage/controls	Symptom	mod-driving condition-at cruise
Commodity	powertrain-engine-accel pedal/linkage/controls	Symptom	mod-driving condition-in park
Commodity	powertrain-engine-accel pedal/linkage/controls	Symptom	mod-no indication (sudden)
Commodity	powertrain-engine-accel pedal/linkage/controls	Symptom	mod-vehicle towed in
Commodity	powertrain-engine-accel pedal/linkage/controls	Symptom	pedal concerns-accelerator pedal
Commodity	powertrain-engine-accel pedal/linkage/controls	Symptom	sticks/binds/grabs
Significant Event		Verified	Y

Tread Information

Report Details

Source Claim Key		ODI 10160004	Warranty Component Classification (WCC)	
Corporate Product Systems Classification (CPSC)			Time in Service	
Customer Condition Code			V Function Group (VFG)	
Source System Program Type			Repair/Report/Paid Date	02-May-2006
Version Series Code	UNKN		Load Date	19-Jul-2006
Causal Part Prefix-Base-Suffix	-		Dealer Code	
Causal Part Name	NOT PROVIDED BY SOURCE		Dealer Name	NOT PROVIDED BY SOURCE
Non Causal Part Prefix-Base-Suffix			Dealer City	
Non Causal Part Numbers			Dealer State/Province	
Fault Code			Dealer Country	USA
Diagnostic Trouble Code			Dealer Phone Number	
Labor Operation Code			Attachment	
Communication Type			VOQ Component Description Code	
Maintenance Date	19-Jul-2006			

Customer Comment
 DT* THE CONTACT STATED WHILE DRIVING ABOUT 30 MPH, WITH ACCELERATOR PRESSURE APPLIED, THE ACCELERATOR PEDAL PULLED TO THE FLOOR WITHOUT WARNING. THE VEHICLE ACCELERATED AT A HIGH SPEED ONTO THE HIGHWAY. THE CONTACT ATTEMPTED TO DISENGAGE THE ACCELERATOR PEDAL BY PUMPING THE PEDAL SEVERAL TIMES WITHOUT SUCCESS. THE VEHICLE SLOWLY RESPONDED TO BRAKE PRESSURE AND THE VEHICLE WAS PLACED IN PARK. WHILE PARKED, THE ENGINE REVVED UNTIL THE IGNITION WAS TURNED OFF. THE VEHICLE WAS TOWED TO A DEALER WHO DETERMINED THE CASING ON THE CRUISE CONTROL CRACKED WHICH CAUSED THE CRUISE CONTROL CABLE TO STICK, ALTHOUGH THE CRUISE CONTROL WAS NOT ENGAGED AT THAT TIME. THE DEALER REPLACED THE CRUISE CONTROL CASING AND CABLES WHICH CORRECTED THE PROBLEM. THE VALVE COVER AND GASKET WERE REPLACED. UPDATED 07/07/06

Technician Comment
CQIS Recommendations

Tire Information

Tire Manufacturer	Unknown	Tire Size	Unknown
Tire Brand Series		Wheel	
DOT Left Front		DOT Right Front	
DOT Left Rear		DOT Right Rear	
DOT Left Inner		DOT Right Inner	
DOT Spare			

Vehicle Information

VIN	*4F2YZ	Engine Serial Number	UNKNOWN
Model Year	2003	Engine Description	Unknown
Transmission	Unknown	Vehicle Description	TRIBUTE
Body Cab Style	UNKN Unknown	Drive Line	Unknown
Production Date		Retail Sale Indicator Code	
Plant Description	Unknown	Required Vehicle	
Build Region		Warranty Start Date	12-Mar-2006
Build Country Code		Transmission Serial Number	UNKNOWN
Mileage	58000	Vehicle Axle Ratio	
Vehicle Restraint Code			

Disclaimer:

This data is for use as one of several potential "awareness" indicators for the Ford Motor Co. Enhanced Concern Identification System. It is unverified, draft, summary data generated from a computer "word search" of customer and technician symptom comments. Supplier data, technician and customer comments are unverified and actual root cause of any potential issue is not established by this summary.

[Contact ODRHELP](#)

Copyright 2001 Ford Motor Co All Rights Reserved

PE12-019

MADZA

9/6/2012

APPENDIX 3 SUBJECT
VEHICLES

Consumer Reports

VOQ Mazda

ECI

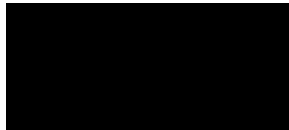



Concern Driven Reporting

Report Detail

Note: Field which are grayed (ghosted) are currently being mapped to the data warehouse. They are not presently being populated.

ECI Record		Source Code	VOQ Mazda
------------	--	-------------	-----------

Commodity Assignment			
Commodity	powertrain-engine-accel pedal/linkage/controls	Symptom	field service action
Commodity	powertrain-engine-accel pedal/linkage/controls	Symptom	function-false activation/cycle/deploy
Commodity	powertrain-engine-accel pedal/linkage/controls	Symptom	mod-driving condition-at cruise
Commodity	powertrain-engine-accel pedal/linkage/controls	Symptom	pedal concerns-accelerator pedal
Commodity	powertrain-engine-accel pedal/linkage/controls	Symptom	sticks/binds/grabs
Significant Event	Personal Injury;	Verified	Y

Tread Information

Report Details

Source Claim Key		ODI 101/0988	Warranty Component Classification (WCC)	
Corporate Product Systems Classification (CPSC)			Time in Service	
Customer Condition Code			V Function Group (VFG)	
Source System Program Type			Repair/Report/Paid Date	16-Oct-2006
Version Series Code	UNKN		Load Date	25-Oct-2006
Causal Part Prefix- Base - Suffix	-		Dealer Code	
Causal Part Name	NOT PROVIDED BY SOURCE		Dealer Name	NOT PROVIDED BY SOURCE
Non Causal Part Prefix-Base-Suffix			Dealer City	
Non Causal Part Numbers			Dealer State/Province	
Fault Code			Dealer Country	USA
Diagnostic Trouble Code			Dealer Phone Number	
Labor Operation Code			Attachment	
Communication Type			VOQ Component Description Code	
Maintenance Date	25-Oct-2006			

Customer Comment	2002 MAZDA TRIBUTE. ON 10/12/2006 WHILE MY WIFE WAS DRIVING THE MENTIONED VEHICLE IT ACCELERATED BY ITSELF TO SPEEDS IN EXCESS OF 55 MILES PER HOUR, WHILE SHE WAS IN A TARGET STORE PARKING LOT. IT DID NOT BRAKE OR STOP UNTIL IT HIT AN STOP SIGN AND MY WIFE WAS ABLE TO TURN THE IGNITION OFF. THE POLICE DEPT. OF THE CITY OF DAVIE WAS CALLED, THEY VERIFIED IT WAS SOME MECHANICAL PROBLEM WITH THE ACCELERATOR. NO TICKETS WERE ISSUED. WE CALLED THE AAA AND THE DRIVER INFORMED US THAT THE THROTTLE CABLE WAS STUCK AND THAT PRODUCED THE ACCELERATION. WE CALLED THE MAZDA DEALERSHIP WHERE THE VEHICLE WAS PURCHASED. THEY STATED THAT THERE WAS A RECALL FOR THE THROTTLE AND TO BRING THE CAR IN FOR SERVICE. MY WIFE AND SON BROUGHT THE CAR IN UNDER THE IMPRESSION THAT THEY WILL TAKE CARE OF THIS PROBLEM. THEY SAID WHEN THE CAR WAS READY IT COST \$157.20 AND IT HAD TO BE PAID OR THE CAR WOULD NOT BE RELEASED. SAID THAT MY SON AUTHORIZED THE CHARGE. HAD TO PAY TO HAVE CAR RELEASED. MAZDA SHOULD PAY. *NM		
Technician Comment			
CQIS Recommendations			

Tire Information

Tire Manufacturer	Unknown	Tire Size	Unknown
Tire Brand Series		Wheel	
DOT Left Front		DOT Right Front	
DOT Left Rear		DOT Right Rear	
DOT Left Inner		DOT Right Inner	
DOT Spare			

Vehicle Information

VIN	*4F2C0	Engine Serial Number	UNKNOWN
Model Year	2002	Engine Description	Unknown
Transmission	Unknown	Vehicle Description	TRIBUTE
Body Cab Style	UNKN Unknown	Drive Line	Unknown
Production Date		Retail Sale Indicator Code	
Plant Description	Unknown	Required Vehicle	
Build Region		Warranty Start Date	
Build Country Code		Transmission Serial Number	UNKNOWN
Mileage	37918	Vehicle Axle Ratio	
Vehicle Restraint Code			

Disclaimer:

This data is for use as one of several potential "awareness" indicators for the Ford Motor Co. Enhanced Concern Identification System. It is unverified, draft, summary data generated from a computer "word search" of customer and technician symptom comments. Supplier data, technician and customer comments are unverified and actual root cause of any potential issue is not established by this summary.

[Contact ODRHELP](#)

Copyright 2001 Ford Motor Co All Rights Reserved

PE12-019

MADZA

9/6/2012

APPENDIX 3 SUBJECT
VEHICLES

Consumer Reports

VOQ Mazda

ECI

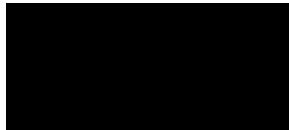



Concern Driven Reporting

Report Detail

Note: Field which are grayed (ghosted) are currently being mapped to the data warehouse. They are not presently being populated.

ECI Record		Source Code	VOQ Mazda
------------	--	-------------	-----------

Commodity Assignment

Commodity	powertrain-engine-accel pedal/linkage/controls	Symptom	circuit-poor contact/poor ground
Commodity	powertrain-engine-accel pedal/linkage/controls	Symptom	damage-cracked/fractured/split
Commodity	powertrain-engine-accel pedal/linkage/controls	Symptom	damage-terminal/connector
Commodity	powertrain-engine-accel pedal/linkage/controls	Symptom	field service action
Commodity	powertrain-engine-accel pedal/linkage/controls	Symptom	mod-driving condition-at idle
Commodity	powertrain-engine-accel pedal/linkage/controls	Symptom	mod-driving condition-on deceleration/braking
Commodity	powertrain-engine-accel pedal/linkage/controls	Symptom	nvh-noisy operation
Commodity	powertrain-engine-accel pedal/linkage/controls	Symptom	pedal concerns-accelerator pedal
Commodity	powertrain-engine-accel pedal/linkage/controls	Symptom	repair-prior repair mentioned
Commodity	powertrain-engine-accel pedal/linkage/controls	Symptom	sticks/binds/grabs
Significant Event		Verified	Y

Tread Information

Report Details

Source Claim Key		ODI 10178811	Warranty Component Classification (WCC)	
Corporate Product Systems Classification (CPSC)			Time in Service	
Customer Condition Code			V Function Group (VFG)	
Source System Program Type			Repair/Report/Paid Date	14-Jan-2007
Version Series Code	UNKN		Load Date	24-Jan-2007
Causal Part Prefix-Base-Suffix	-		Dealer Code	
Causal Part Name	NOT PROVIDED BY SOURCE		Dealer Name	NOT PROVIDED BY SOURCE
Non Causal Part Prefix-Base-Suffix			Dealer City	
Non Causal Part Numbers			Dealer State/Province	
Fault Code			Dealer Country	USA
Diagnotic Trouble Code			Dealer Phone Number	
Labor Operation Code			Attachment	
Communication Type			VOQ Component Description Code	
Maintenance Date	24-Jan-2007			

Customer Comment
 TL* THE CONTACT STATED THAT WHILE DRIVING A 2004 MAZDA TRIBUTE AT 25 MPH THE ACCELERATOR PEDAL GOT STUCK. THE CONTACT APPLIED THE BRAKES AND THE VEHICLE WOULDN'T COME TO A COMPLETE STOP, UNTIL THE CONTACT HEARD A POPPING NOISE, THAT'S WHEN THE VEHICLE SHIFTED INTO IDLE. WHILE INSPECTING THE VEHICLE THE CONTACT NOTICED THAT THE ACCELERATOR CABLE HAD SNAPPED. THE CONTACT TOOK THE VEHICLE TO THE DEALERSHIP (D DAHLE MAZDA IN MURRAY, UT) AND THEY STATED THAT THE CONTACT WOULD HAVE TO PAY FOR THE REPAIR SINCE THEY HAD ALREADY PERFORM THE RECALL REPAIR FOR CONTACT NHTSA CAMPAIGN ID NUMBER 04V583000. THE CONTACT CAN PROVIDE PICTURES IF NEEDED.

Technician Comment

CQIS Recommendations

Tire Information

Tire Manufacturer	Unknown	Tire Size	Unknown
Tire Brand Series		Wheel	
DOT Left Front		DOT Right Front	
DOT Left Rear		DOT Right Rear	
DOT Left Inner		DOT Right Inner	
DOT Spare			

Vehicle Information

VIN	*4F2Y2	Engine Serial Number	UNKNOWN
Model Year	2004	Engine Description	Unknown
Transmission	Unknown	Vehicle Description	TRIBUTE
Body Cab Style	UNKN Unknown	Drive Line	Unknown
Production Date		Retail Sale Indicator Code	
Plant Description	Unknown	Reaquired Vehicle	
Build Region		Warranty Start Date	
Build Country Code		Transmission Serial Number	UNKNOWN
Mileage	53200	Vehicle Axle Ratio	
Vehicle Restraint Code			

Disclaimer:

This data is for use as one of several potential "awareness" indicators for the Ford Motor Co. Enhanced Concern Identification System. It is unverified, draft, summary data generated from a computer "word search" of customer and technician symptom comments. Supplier data, technician and customer comments are unverified and actual root cause of any potential issue is not established by this summary.

[Contact ODRHELP](#)

Copyright 2001 Ford Motor Co All Rights Reserved

PE12-019

MADZA

9/6/2012

APPENDIX 3 SUBJECT
VEHICLES

Consumer Reports

VOQ Mazda

ECI

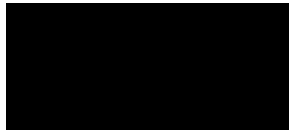



Concern Driven Reporting

Report Detail

Note: Field which are grayed (ghosted) are currently being mapped to the data warehouse. They are not presently being populated.

ECI Record		Source Code	VOQ Mazda
------------	--	-------------	-----------

Commodity Assignment			
Commodity	powertrain-engine-accel pedal/linkage/controls	Symptom	field service action
Commodity	powertrain-engine-accel pedal/linkage/controls	Symptom	function-malfunction/inoperative
Commodity	powertrain-engine-accel pedal/linkage/controls	Symptom	mod-driving condition-at cruise
Commodity	powertrain-engine-accel pedal/linkage/controls	Symptom	mod-driving condition-engine-hot
Commodity	powertrain-engine-accel pedal/linkage/controls	Symptom	mod-driving condition-on acceleration
Commodity	powertrain-engine-accel pedal/linkage/controls	Symptom	mod-driving condition-on deceleration/braking
Commodity	powertrain-engine-accel pedal/linkage/controls	Symptom	mod-driving condition-while driving
Commodity	powertrain-engine-accel pedal/linkage/controls	Symptom	mod-weather-cold
Commodity	powertrain-engine-accel pedal/linkage/controls	Symptom	pedal concerns-accelerator pedal
Commodity	powertrain-engine-accel pedal/linkage/controls	Symptom	repair-prior repair mentioned
Commodity	powertrain-engine-accel pedal/linkage/controls	Symptom	separation
Commodity	powertrain-engine-accel pedal/linkage/controls	Symptom	sticks/binds/grabs
Significant Event	Property Damage;	Verified	Y

Tread Information

Report Details

Source Claim Key	ODI 10181688	Warranty Component Classification (WCC)	
Corporate Product Systems Classification (CPSC)		Time in Service	
Customer Condition Code		V Function Group (VFG)	
Source System Program Type		Repair/Report/Paid Date	03-Feb-2007
Version Series Code	UNKN	Load Date	13-Feb-2007
Causal Part Prefix-Base-Suffix	-	Dealer Code	
Causal Part Name	NOT PROVIDED BY SOURCE	Dealer Name	NOT PROVIDED BY SOURCE
Non Causal Part Prefix-Base-Suffix		Dealer City	
Non Causal Part Numbers		Dealer State/Province	
Fault Code		Dealer Country	USA
Diagnostic Trouble Code		Dealer Phone Number	
Labor Operation Code		Attachment	
Communication Type		VOQ Component Description Code	
Maintenance Date	13-Feb-2007		

Customer Comment	<p>I WAS DRIVING ON A FREEWAY (4 LANE 65 MPH SPEED LIMIT) ON THE AFTERNOON OF 2/3/2007 WITH MY CRUISE CONTROL SET TO 65 MPH. I NOTICED THAT I WAS SPEEDING UP, AND WITHIN A SHORT TIME, MY SPEED HAD CLIMBED TO ABOUT 90 MPH. AT FIRST, I THOUGHT THIS WAS A MALFUNCTION OF MY SPEED CONTROL, BUT AFTER TOUCHING THE BRAKE AND TURNING THE SPEED CONTROL OFF, IT CONTINUED TO GO ABOUT 90 MPH. AT THIS TIME, I NOTICED AN EXIT COMING UP IN ABOUT 1 MILE SO I KEPT TOUCHING THE BREAK TO KEEP THE SPEED ABOUT 75 80 AND WHEN I APPROACHED THE EXIT, SHUT OFF THE CAR AND COASTED TO THE TOP OF THE RAMP. WITH THE CAR SAFELY STOPPED, I WAS ABLE TO GET THE CAR TOWED TO A SERVICE STATION, WHERE THE MECHANIC PULLED OFF THE AIR FILTER ASSEMBLY GOING INTO WHAT I THINK IS A THROTTLE CHAMBER AND FOUND A LARGE PIECE OF ICE HOLDING EITHER THE CHOKE OR THROTTLE CAUSING THE PROBLEM. IT IS IMPORTANT TO NOTE THAT THE TEMPERATURES THAT DAY WERE VERY COLD ABOUT 10 DEGREES F. BELOW ZERO. AFTER REMOVING THE ICE AND CLEANING OUT THE CHAMBER WITH SILICON, AND ALLOWING IT TO WARM UP FOR ABOUT 15 MINUTES EVERYTHING WAS OKAY. I SHOULD NOTE THAT I HAD TAKEN THE VEHICLE INTO THE LOCAL MAZDA DEALER ABOUT A MONTH EARLIER BECAUSE I NOTICED THE THROTTLE WAS STICKING THEY SERVICED IT AND IT SEEMED TO BE OKAY, UNTIL THE INCIDENT ON 2/3/07. WHEN I CALLED THE MAZDA DEALERSHIP, THEY TOLD ME THAT THERE WAS A SAFETY RECALL ON THE THROTTLE ASSEMBLY, BUT THEY SHOWED THIS PART HAD BEEN REPLACED ALREADY. I AM CONCERNED THAT ICE CAN BUILD UP IN THIS AREA AND THE SAME THING WILL HAPPEN AGAIN, WHENEVER IT IS COLD OUT. I HAVEN'T SEEN ANOTHER SIMILAR COMPLAINT, BUT THOUGHT IT WOULD BE A GOOD IDEA TO DOCUMENT THIS THIS COULD HAVE EASILY CAUSED A MAJOR ACCIDENT. *NM</p>		
Technician Comment			
CQIS Recommendations			

Tire Information

Tire Manufacturer	Unknown	Tire Size	Unknown
Tire Brand Series		Wheel	
DOT Left Front		DOT Right Front	
DOT Left Rear		DOT Right Rear	
DOT Left Inner		DOT Right Inner	
DOT Spare			

Vehicle Information

VIN	*4F2YZ	Engine Serial Number	UNKNOWN
Model Year	2004	Engine Description	Unknown
Transmission	Unknown	Vehicle Description	TRIBUTE
Body Cab Style	UNKN Unknown	Drive Line	Unknown
Production Date		Retail Sale Indicator Code	

Plant Description	Unknown	Required Vehicle	
Build Region		Warranty Start Date	
Build Country Code		Transmission Serial Number	UNKNOWN
Mileage	70500	Vehicle Axle Ratio	
Vehicle Restraint Code			

Disclaimer:

This data is for use as one of several potential "awareness" indicators for the Ford Motor Co. Enhanced Concern Identification System. It is unverified, draft, summary data generated from a computer "word search" of customer and technician symptom comments. Supplier data, technician and customer comments are unverified and actual root cause of any potential issue is not established by this summary.

[Contact CDK HELP](#)

Copyright 2001 Ford Motor Co. All Rights Reserved

PE12-019

MADZA

9/6/2012

APPENDIX 3 SUBJECT
VEHICLES

Consumer Reports

VOQ Mazda

ECI

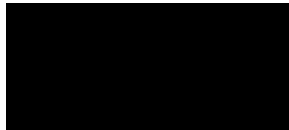



Concern Driven Reporting

Report Detail

Note: Field which are grayed (ghosted) are currently being mapped to the data warehouse. They are not presently being populated.

ECI Record		Source Code	VOQ Mazda
------------	--	-------------	-----------

Commodity Assignment

Commodity	powertrain-engine-accel pedal/linkage/controls	Symptom	function-malfunction/inoperative
Commodity	powertrain-engine-accel pedal/linkage/controls	Symptom	mod-driving condition-while driving
Commodity	powertrain-engine-accel pedal/linkage/controls	Symptom	sticks/binds/grabs
Significant Event		Verified	N

Tread Information

Report Details

Source Claim Key		ODI 891605	Warranty Component Classification (WCC)	
Corporate Product Systems Classification (CPSC)			Time in Service	
Customer Condition Code			V Function Group (VFG)	
Source System Program Type			Repair/Report/Paid Date	23-Jun-2001
Version Series Code	UNKN		Load Date	29-Nov-2007
Causal Part Prefix- Base - Suffix	-		Dealer Code	
Causal Part Name	NOT PROVIDED BY SOURCE		Dealer Name	NOT PROVIDED BY SOURCE
Non Causal Part Prefix-Base-Suffix			Dealer City	
Non Causal Part Numbers			Dealer State/Province	
Fault Code			Dealer Country	USA
Diagnostic Trouble Code			Dealer Phone Number	
Labor Operation Code			Attachment	
Communication Type			VOQ Component Description Code	
Maintenance Date	29-Nov-2007			

Customer Comment	VEHICLE WAS GOING 10 15MPH AND STEPPED ON GAS TO GO 20 25MPH. AND RPMS WERE STICKING,AND BRAKING MADE IT 80 85% LESS EFFECTIVE. DEALER IS CONVINCED THE PROBLEM IS THE FLOOR MATS
Technician Comment	
CQIS Recommendations	

Tire Information

Tire Manufacturer	Unknown	Tire Size	Unknown
Tire Brand Series		Wheel	
DOT Left Front		DOT Right Front	
DOT Left Rear		DOT Right Rear	
DOT Left Inner		DOT Right Inner	
DOT Spare			

Vehicle Information

VIN	*4F2CU	Engine Serial Number	UNKNOWN
Model Year	2001	Engine Description	Unknown
Transmission	Unknown	Vehicle Description	TRIBUTE
Body Cab Style	UNKN Unknown	Drive Line	Unknown
Production Date		Retail Sale Indicator Code	
Plant Description	Unknown	Required Vehicle	
Build Region		Warranty Start Date	
Build Country Code		Transmission Serial Number	UNKNOWN
Mileage	0	Vehicle Axle Ratio	
Vehicle Restraint Code			

Disclaimer:

This data is for use as one of several potential "awareness" indicators for the Ford Motor Co. Enhanced Concern Identification System. It is unverified, draft, summary data generated from a computer "word search" of customer and technician symptom comments. Supplier data, technician and customer comments are unverified and actual root cause of any potential issue is not established by this summary.

Contact ODR FILE

PE12-019

MADZA

9/6/2012

APPENDIX 3 SUBJECT
VEHICLES

Consumer Reports

VOQ Mazda

ECI

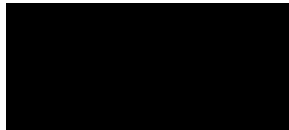



Concern Driven Reporting

Report Detail

Note: Field which are grayed (ghosted) are currently being mapped to the data warehouse. They are not presently being populated.

ECI Record		Source Code	VOQ Mazda
------------	--	-------------	-----------

Commodity Assignment			
Commodity	powertrain-engine-accel pedal/linkage/controls	Symptom	engine power-loss of power
Commodity	powertrain-engine-accel pedal/linkage/controls	Symptom	function-malfunction/inoperative
Commodity	powertrain-engine-accel pedal/linkage/controls	Symptom	mod-driving condition-in neutral
Commodity	powertrain-engine-accel pedal/linkage/controls	Symptom	mod-driving condition-while driving
Commodity	powertrain-engine-accel pedal/linkage/controls	Symptom	mod-location-interior
Significant Event		Verified	N

Tread Information

Report Details

Source Claim Key		ODI 762592	Warranty Component Classification (WCC)	
Corporate Product Systems Classification (CPSC)			Time in Service	
Customer Condition Code			V Function Group (VFG)	
Source System Program Type			Repair/Report/Paid Date	01-Jun-2002
Version Series Code	UNKN		Load Date	29-Nov-2007
Causal Part Prefix-Base-Suffix	-		Dealer Code	
Causal Part Name	NOT PROVIDED BY SOURCE		Dealer Name	NOT PROVIDED BY SOURCE
Non Causal Part Prefix-Base-Suffix			Dealer City	
Non Causal Part Numbers			Dealer State/Province	
Fault Code			Dealer Country	USA
Diagnostic Trouble Code			Dealer Phone Number	
Labor Operation Code			Attachment	
Communication Type			VOQ Component Description Code	
Maintenance Date	29-Nov-2007			

Customer Comment	MAY 23, 2002 CRUISE CONTROL STOPPED WORKING. LIGHT ON CONSOLE COMES ON BUT DOESN'T ENGAGE. JUNE 01, 2002 LOST ALL POWER WHILE GOING APPROX 35 MPH AROUND A SLIGHT CURVE. PULLED TO THE SIDE, PUT IN NEUTRAL AND STARTED AGAIN		
Technician Comment			
CQIS Recommendations			

Tire Information

Tire Manufacturer	Unknown	Tire Size	Unknown
Tire Brand Series		Wheel	
DOT Left Front		DOT Right Front	
DOT Left Rear		DOT Right Rear	
DOT Left Inner		DOT Right Inner	
DOT Spare			

Vehicle Information

VIN	*4F2CU	Engine Serial Number	UNKNOWN
Model Year	2001	Engine Description	Unknown
Transmission	Unknown	Vehicle Description	TRIBUTE
Body Cab Style	UNKN Unknown	Drive Line	Unknown
Production Date		Retail Sale Indicator Code	
Plant Description	Unknown	Required Vehicle	
Build Region		Warranty Start Date	
Build Country Code		Transmission Serial Number	UNKNOWN
Mileage	0	Vehicle Axle Ratio	
Vehicle Restraint Code			

Disclaimer:

This data is for use as one of several potential "awareness" indicators for the Ford Motor Co. Enhanced Concern Identification System. It is unverified, draft, summary data generated from a computer "word search" of customer and technician symptom comments. Supplier data, technician and customer comments are unverified and actual root cause of any potential issue is not established by this summary.

[Contact ODRHELP](#)

Copyright 2001 Ford Motor Co All Rights Reserved

PE12-019

MADZA

9/6/2012

APPENDIX 3 SUBJECT
VEHICLES

Consumer Reports

VOQ Mazda

ECI

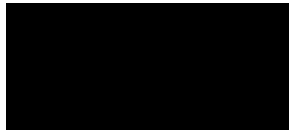



Concern Driven Reporting

Report Detail

Note: Field which are grayed (ghosted) are currently being mapped to the data warehouse. They are not presently being populated.

ECI Record	██████████	Source Code	VOQ Mazda
------------	------------	-------------	-----------

Commodity Assignment

Commodity	powertrain-engine-accel pedal/linkage/controls	Symptom	engine power-hesitates
Commodity	powertrain-engine-accel pedal/linkage/controls	Symptom	mod-no indication (sudden)
Commodity	powertrain-engine-accel pedal/linkage/controls	Symptom	pedal concerns-accelerator pedal
Commodity	powertrain-engine-accel pedal/linkage/controls	Symptom	unintended acceleration
Significant Event		Verified	N

Tread Information

Report Details

Source Claim Key	██████████ ODI 10027270	Warranty Component Classification (WCC)	
Corporate Product Systems Classification (CPSC)		Time in Service	
Customer Condition Code		V Function Group (VFG)	
Source System Program Type		Repair/Report/Paid Date	14-Jul-2003
Version Series Code	UNKN	Load Date	29-Nov-2007
Causal Part Prefix-Base-Suffix	- -	Dealer Code	
Causal Part Name	NOT PROVIDED BY SOURCE	Dealer Name	NOT PROVIDED BY SOURCE
Non Causal Part Prefix-Base-Suffix		Dealer City	
Non Causal Part Numbers		Dealer State/Province	
Fault Code		Dealer Country	USA
Diagonstic Trouble Code		Dealer Phone Number	
Labor Operation Code		Attachment	
Communication Type		VOQ Component Description Code	
Maintenance Date	29-Nov-2007		

Customer Comment	CONSUMER DEPRESSED ACCELERATOR PEDAL AND VEHICLE HESITATED, AND THEN SUDDENLY LURCHED FORWARD, ALMOST CAUSING A COLLISION. RELATED INVESTIGATION EA 02 027.*A		
Technician Comment			
C Q I S Recommendations			

Tire Information

Tire Manufacturer	Unknown	Tire Size	Unknown
Tire Brand Series		Wheel	
DOT Left Front		DOT Right Front	
DOT Left Rear		DOT Right Rear	
DOT Left Inner		DOT Right Inner	
DOT Spare			

Vehicle Information

VIN	*4F2YU ██████████	Engine Serial Number	UNKNOWN
Model Year	2001	Engine Description	Unknown
Transmission	Unknown	Vehicle Description	TRIBUTE
Body Cab Style	UNKN Unknown	Drive Line	Unknown
Production Date		Retail Sale Indicator Code	
Plant Description	Unknown	Reaquired Vehicle	
Build Region		Warranty Start Date	
Build Country Code		Transmission Serial Number	UNKNOWN
Mileage	0	Vehicle Axle Ratio	
Vehicle Restraint Code			

Disclaimer:

This data is for use as one of several potential "awareness" indicators for the Ford Motor Co. Enhanced Concern Identification System. It is unverified, draft, summary data generated from a computer "word search" of customer and technician symptom comments. Supplier data, technician and customer comments are unverified and actual root cause of any potential issue is not established by this summary.

PE12-019

MADZA

9/6/2012

APPENDIX 3 SUBJECT
VEHICLES

Consumer Reports

VOQ Mazda

ECI

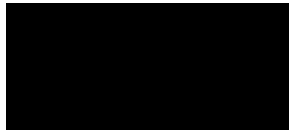



Concern Driven Reporting

Report Detail

Note: Field which are grayed (ghosted) are currently being mapped to the data warehouse. They are not presently being populated.

ECI Record		Source Code	VOQ Mazda
------------	--	-------------	-----------

Commodity Assignment			
Commodity	powertrain-engine-accel pedal/linkage/controls	Symptom	function-malfunction/inoperative
Commodity	powertrain-engine-accel pedal/linkage/controls	Symptom	mod-driving condition-on acceleration
Commodity	powertrain-engine-accel pedal/linkage/controls	Symptom	mod-driving condition-while driving
Commodity	powertrain-engine-accel pedal/linkage/controls	Symptom	pedal concerns-accelerator pedal
Commodity	powertrain-engine-accel pedal/linkage/controls	Symptom	sticks/binds/grabs
Significant Event		Verified	N

Tread Information

Report Details

Source Claim Key		ODI I0010623	Warranty Component Classification (WCC)	
Corporate Product Systems Classification (CPS)			Time in Service	
Customer Condition Code			V Function Group (VFG)	
Source System Program Type			Repair/Report/Paid Date	12-Feb-2003
Version Series Code	UNKN		Load Date	29-Nov-2007
Causal Part Prefix-Base-Suffix	-		Dealer Code	
Causal Part Name	NOT PROVIDED BY SOURCE		Dealer Name	NOT PROVIDED BY SOURCE
Non Causal Part Prefix-Base-Suffix			Dealer City	
Non Causal Part Numbers			Dealer State/Province	
Fault Code			Dealer Country	USA
Diagnostic Trouble Code			Dealer Phone Number	
Labor Operation Code			Attachment	
Communication Type			VOQ Component Description Code	
Maintenance Date	29-Nov-2007			

Customer Comment	THROTTLE STICKS WHEN ACCELERATING FROM COMPLETE STOP DUE TO BUILD UP ON THROTTLE PLATE. OWNER HAS PROVIDED MAINTENANCE AND FUEL AS SPECIFIED IN MANUAL, YET WAS TOLD MAZDA DOES NOT COVER UNDER WARRANTY. PROBLEM APPEARED WITH LESS THAN 15000 MILES. CLEANING (AT OWNER COST) PROVIDES ONLY SHORT TERM REMEDY. *NL
Technician Comment	
CQIS Recommendations	

Tire Information

Tire Manufacturer	Unknown	Tire Size	Unknown
Tire Brand Series		Wheel	
DOT Left Front		DOT Right Front	
DOT Left Rear		DOT Right Rear	
DOT Left Inner		DOT Right Inner	
DOT Spare			

Vehicle Information

VIN	*4F2CU	Engine Serial Number	UNKNOWN
Model Year	2002	Engine Description	Unknown
Transmission	Unknown	Vehicle Description	TRIBUTE
Body Cab Style	UNKN Unknown	Drive Line	Unknown
Production Date		Retail Sale Indicator Code	
Plant Description	Unknown	Required Vehicle	
Build Region		Warranty Start Date	
Build Country Code		Transmission Serial Number	UNKNOWN
Mileage	0	Vehicle Axle Ratio	
Vehicle Restraint Code			

Disclaimer:

This data is for use as one of several potential "awareness" indicators for the Ford Motor Co. Enhanced Concern Identification System. It is unverified, draft, summary data generated from a computer "word search" of customer and technician symptom comments. Supplier data, technician and customer comments are unverified and actual root cause of any potential issue is not established by this summary.

[Contact ODRHELP](#)

Copyright 2001 Ford Motor Co All Rights Reserved

PE12-019

MADZA

9/6/2012

APPENDIX 3 SUBJECT
VEHICLES

Consumer Reports

VOQ Mazda

ECI

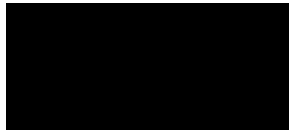



Concern Driven Reporting

Report Detail

Note: Field which are grayed (ghosted) are currently being mapped to the data warehouse. They are not presently being populated.

ECI Record		Source Code	VOQ Mazda
------------	--	-------------	-----------

Commodity Assignment			
Commodity	powertrain-engine-accel pedal/linkage/controls	Symptom	contaminated/foreign
Commodity	powertrain-engine-accel pedal/linkage/controls	Symptom	pedal concerns-accelerator pedal
Commodity	powertrain-engine-accel pedal/linkage/controls	Symptom	sticks/binds/grabs
Commodity	powertrain-engine-accel pedal/linkage/controls	Symptom	unintended acceleration
Significant Event		Verified	N

Tread Information

Report Details

Source Claim Key		ODI 10047269	Warranty Component Classification (WCC)	
Corporate Product Systems Classification (CPSC)			Time in Service	
Customer Condition Code			V Function Group (VFG)	
Source System Program Type			Repair/Report/Paid Date	17-Nov-2003
Version Series Code	UNKN		Load Date	29-Nov-2007
Causal Part Prefix-Base-Suffix	-		Dealer Code	
Causal Part Name	NOT PROVIDED BY SOURCE		Dealer Name	NOT PROVIDED BY SOURCE
Non Causal Part Prefix-Base-Suffix			Dealer City	
Non Causal Part Numbers			Dealer State/Province	
Fault Code			Dealer Country	USA
Diagonstic Trouble Code			Dealer Phone Number	
Labor Operation Code			Attachment	
Communication Type			VOQ Component Description Code	
Maintenance Date	29-Nov-2007			

Customer Comment	ACCELERATOR PEDAL IS STICKY RIGHT FROM THE START OF DEPRESSING THE PEDAL. ONCE THE RESISTANCE IS OVERCOME THE VEHICLE LURCHES FORWARD. DEALER CLAIMS CARBON BUILD UP (CONTAMINATION) ON OR NEAR THE THROTTLE PLATE IS CAUSING INITIAL RESISTANCE. TWO OCCURRENCES (APPROXIMATELY 5,000 AND 10,000 MILES) HAVE RESULTED IN DEALER CLEANING AREA TO REMOVE CONTAMINATION. *L		
Technician Comment			
CQIS Recommendations			

Tire Information

Tire Manufacturer	Unknown	Tire Size	Unknown
Tire Brand Series		Wheel	
DOT Left Front		DOT Right Front	
DOT Left Rear		DOT Right Rear	
DOT Left Inner		DOT Right Inner	
DOT Spare			

Vehicle Information

VIN	*4F2CZ	Engine Serial Number	UNKNOWN
Model Year	2003	Engine Description	Unknown
Transmission	Unknown	Vehicle Description	TRIBUTE
Body Cab Style	UNKN Unknown	Drive Line	Unknown
Production Date		Retail Sale Indicator Code	
Plant Description	Unknown	Reaquired Vehicle	
Build Region		Warranty Start Date	12-Mar-2006
Build Country Code		Transmission Serial Number	UNKNOWN
Mileage	10500	Vehicle Axle Ratio	
Vehicle Restraint Code			

Disclaimer:

This data is for use as one of several potential "awareness" indicators for the Ford Motor Co. Enhanced Concern Identification System. It is unverified, draft, summary data generated from a computer "word search" of customer and technician symptom comments. Supplier data, technician and customer comments are unverified and actual root cause of any potential issue is not established by this summary.

[Contact ODRHELP](#)

Copyright 2001 Ford Motor Co All Rights Reserved

PE12-019

MADZA

9/6/2012

APPENDIX 3 SUBJECT
VEHICLES

Consumer Reports

VOQ Mazda

ECI

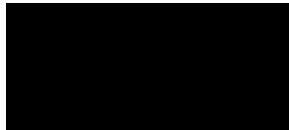



Concern Driven Reporting

Report Detail

Note: Field which are grayed (ghosted) are currently being mapped to the data warehouse. They are not presently being populated.

ECI Record		Source Code	VOQ Mazda
------------	--	-------------	-----------

Commodity Assignment

Commodity	powertrain-engine-accel pedal/linkage/controls	Symptom	function-malfunction/inoperative
Commodity	powertrain-engine-accel pedal/linkage/controls	Symptom	mod-driving condition-at start up
Commodity	powertrain-engine-accel pedal/linkage/controls	Symptom	mod-driving condition-engine-cold
Commodity	powertrain-engine-accel pedal/linkage/controls	Symptom	pedal concerns-accelerator pedal
Commodity	powertrain-engine-accel pedal/linkage/controls	Symptom	sticks/binds/grabs
Commodity	powertrain-engine-accel pedal/linkage/controls	Symptom	unintended acceleration
Significant Event		Verified	N

Tread Information

Report Details

Source Claim Key		ODI 10046572	Warranty Component Classification (WCC)	
Corporate Product Systems Classification (CPSC)			Time in Service	
Customer Condition Code			V Function Group (VFG)	
Source System Program Type			Repair/Report/Paid Date	10-Dec-2002
Version Series Code	UNKN		Load Date	29-Nov-2007
Causal Part Prefix-Base-Suffix	-		Dealer Code	
Causal Part Name	NOT PROVIDED BY SOURCE		Dealer Name	NOT PROVIDED BY SOURCE
Non Causal Part Prefix-Base-Suffix			Dealer City	
Non Causal Part Numbers			Dealer State/Province	
Fault Code			Dealer Country	USA
Diagnostic Trouble Code			Dealer Phone Number	
Labor Operation Code			Attachment	
Communication Type			VOQ Component Description Code	
Maintenance Date	29-Nov-2007			

Customer Comment	WHEN IT IS COLD THE ACCELERATOR STICKS AFTER GOING ABOUT AN INCH. WHEN THE ACCELERATOR BECOMES UNLOCKED IT CAUSES THE VEHICLE TO LURCH FORWARD. THE VEHICLE WAS TAKEN TO A DEALER, WHO INFORMED THE CONSUMER THAT THERE WAS A CARBON BUILDUP ON THE CABLE. THIS INCIDENT OCCURRED AT LEAST TWENTY FIVE TIMES. THE MANUFACTURER WAS AWARE OF THE PROBLEM.*A
Technician Comment	
CQIS Recommendations	

Tire Information

Tire Manufacturer	Unknown	Tire Size	Unknown
Tire Brand Series		Wheel	
DOT Left Front		DOT Right Front	
DOT Left Rear		DOT Right Rear	
DOT Left Inner		DOT Right Inner	
DOT Spare			

Vehicle Information

VIN	*	Engine Serial Number	UNKNOWN
Model Year	2003	Engine Description	Unknown
Transmission	Unknown	Vehicle Description	TRIBUTE
Body Cab Style	UNKN Unknown	Drive Line	Unknown
Production Date		Retail Sale Indicator Code	
Plant Description	Unknown	Reaquired Vehicle	
Build Region		Warranty Start Date	12-Mar-2006
Build Country Code		Transmission Serial Number	UNKNOWN
Mileage	7200	Vehicle Axle Ratio	
Vehicle Restraint Code			

Disclaimer:

This data is for use as one of several potential "awareness" indicators for the Ford Motor Co. Enhanced Concern Identification System. It is unverified, draft, summary data generated from a computer "word search" of customer and technician symptom comments. Supplier data, technician and customer comments are unverified and actual root cause of any potential issue is not established by this summary.

[Contact ODRHELP](#)

Copyright 2001 Ford Motor Co All Rights Reserved

PE12-019

MADZA

9/6/2012

APPENDIX 3 SUBJECT
VEHICLES

Consumer Reports

VOQ Mazda

ECI

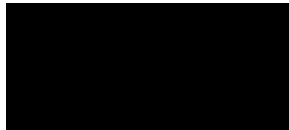



Concern Driven Reporting

Report Detail

Note: Field which are grayed (ghosted) are currently being mapped to the data warehouse. They are not presently being populated.

ECI Record		Source Code	VOQ Mazda
------------	--	-------------	-----------

Commodity Assignment

Commodity	powertrain-engine-accel pedal/linkage/controls	Symptom	pedal concerns-accelerator pedal
Commodity	powertrain-engine-accel pedal/linkage/controls	Symptom	sticks/binds/grabs
Significant Event	Property Damage;	Verified	N

Tread Information

Report Details

Source Claim Key	ODI 10046790	Warranty Component Classification (WCC)	
Corporate Product Systems Classification (CPSC)		Time in Service	
Customer Condition Code		V Function Group (VFG)	
Source System Program Type		Repair/Report/Paid Date	11-Nov-2003
Version Series Code	UNKN	Load Date	29-Nov-2007
Causal Part Prefix-Base-Suffix	--	Dealer Code	
Causal Part Name	NOT PROVIDED BY SOURCE	Dealer Name	NOT PROVIDED BY SOURCE
Non Causal Part Prefix-Base-Suffix		Dealer City	
Non Causal Part Numbers		Dealer State/Province	
Fault Code		Dealer Country	USA
Diagnostic Trouble Code		Dealer Phone Number	
Labor Operation Code		Attachment	
Communication Type		VOQ Component Description Code	
Maintenance Date	29-Nov-2007		

Customer Comment	ACCELERATOR PEDAL STUCK ON 2004 MAZDA TRIBUTE. *L
Technician Comment	
CQIS Recommendations	

Tire Information

Tire Manufacturer	Unknown	Tire Size	Unknown
Tire Brand Series		Wheel	
DOT Left Front		DOT Right Front	
DOT Left Rear		DOT Right Rear	
DOT Left Inner		DOT Right Inner	
DOT Spare			

Vehicle Information

VIN	*	Engine Serial Number	UNKNOWN
Model Year	2004	Engine Description	Unknown
Transmission	Unknown	Vehicle Description	TRIBUTE
Body Cab Style	UNKN Unknown	Drive Line	Unknown
Production Date		Retail Sale Indicator Code	
Plant Description	Unknown	Required Vehicle	
Build Region		Warranty Start Date	
Build Country Code		Transmission Serial Number	UNKNOWN
Mileage	2200	Vehicle Axle Ratio	
Vehicle Restraint Code			

Disclaimer:

This data is for use as one of several potential "awareness" indicators for the Ford Motor Co. Enhanced Concern Identification System. It is unverified, draft, summary data generated from a computer "word search" of customer and technician symptom comments. Supplier data, technician and customer comments are unverified and actual root cause of any potential issue is not established by this summary.

[Contact CDR HELP](#)
Copyright 2001 Ford Motor Co. All Rights Reserved

PE12-019

MADZA

9/6/2012

APPENDIX 3 SUBJECT
VEHICLES

Consumer Reports

VOQ Mazda

ECI

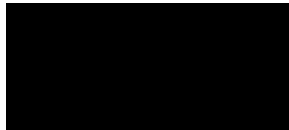



Concern Driven Reporting

Report Detail

Note: Field which are grayed (ghosted) are currently being mapped to the data warehouse. They are not presently being populated.

ECI Record		Source Code	VOQ Mazda
------------	--	-------------	-----------

Commodity Assignment

Commodity	powertrain-engine-accel pedal/linkage/controls	Symptom	function-malfunction/inoperative
Commodity	powertrain-engine-accel pedal/linkage/controls	Symptom	high effort
Commodity	powertrain-engine-accel pedal/linkage/controls	Symptom	pedal concerns-accelerator pedal
Commodity	powertrain-engine-accel pedal/linkage/controls	Symptom	pedal concerns-pedal positions
Commodity	powertrain-engine-accel pedal/linkage/controls	Symptom	sticks/binds/grabs
Significant Event		Verified	N

Tread Information

Report Details

Source Claim Key		ODI I0053779	Warranty Component Classification (WCC)	
Corporate Product Systems Classification (CPS)			Time in Service	
Customer Condition Code			V Function Group (VFG)	
Source System Program Type			Repair/Report/Paid Date	01-Nov-2003
Version Series Code	UNKN		Load Date	29-Nov-2007
Causal Part Prefix-Base-Suffix	-		Dealer Code	
Causal Part Name	NOT PROVIDED BY SOURCE		Dealer Name	NOT PROVIDED BY SOURCE
Non Causal Part Prefix-Base-Suffix			Dealer City	
Non Causal Part Numbers			Dealer State/Province	
Fault Code			Dealer Country	USA
Diagnostic Trouble Code			Dealer Phone Number	
Labor Operation Code			Attachment	
Communication Type			VOQ Component Description Code	
Maintenance Date	29-Nov-2007			

Customer Comment	THE ACCELERATOR PEDAL STUCK ON TWO SEPARATE OCCASIONS. THIS OCCURRED WHILE ACCELERATING FROM A STOP POSITION. AS A RESULT, EXCESSIVE FORCE HAD TO BE APPLIED TO THE PEDAL WHICH RESULTED IN RAPID ACCELERATION. BOTH FAILURES WERE DUE TO THE THROTTLE BODY.*AK *M
Technician Comment	
CQIS Recommendations	

Tire Information

Tire Manufacturer	Unknown	Tire Size	Unknown
Tire Brand Series		Wheel	
DOT Left Front		DOT Right Front	
DOT Left Rear		DOT Right Rear	
DOT Left Inner		DOT Right Inner	
DOT Spare			

Vehicle Information

VIN	*4F2C0	Engine Serial Number	UNKNOWN
Model Year	2001	Engine Description	Unknown
Transmission	Unknown	Vehicle Description	TRIBUTE
Body Cab Style	UNKN Unknown	Drive Line	Unknown
Production Date		Retail Sale Indicator Code	
Plant Description	Unknown	Required Vehicle	
Build Region		Warranty Start Date	
Build Country Code		Transmission Serial Number	UNKNOWN
Mileage	20000	Vehicle Axle Ratio	
Vehicle Restraint Code			

Disclaimer:

This data is for use as one of several potential "awareness" indicators for the Ford Motor Co. Enhanced Concern Identification System. It is unverified, draft, summary data generated from a computer "word search" of customer and technician symptom comments. Supplier data, technician and customer comments are unverified and actual root cause of any potential issue is not established by this summary.

[Contact ODRHELP](#)

Copyright 2001 Ford Motor Co All Rights Reserved

PE12-019

MADZA

9/6/2012

APPENDIX 3 SUBJECT
VEHICLES

Consumer Reports

VOQ Mazda

ECI

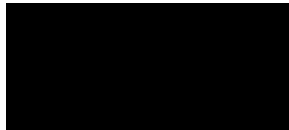



Concern Driven Reporting

Report Detail

Note: Field which are grayed (ghosted) are currently being mapped to the data warehouse. They are not presently being populated.

ECI Record		Source Code	VOQ Mazda
------------	--	-------------	-----------

Commodity Assignment			
Commodity	powertrain-engine-accel pedal/linkage/controls	Symptom	damage
Commodity	powertrain-engine-accel pedal/linkage/controls	Symptom	engine rpm surge/flare
Commodity	powertrain-engine-accel pedal/linkage/controls	Symptom	unintended acceleration
Significant Event	Property Damage;	Verified	N

Tread Information

Report Details

Source Claim Key		ODI 10082337	Warranty Component Classification (WCC)	
Corporate Product Systems Classification (CPSC)			Time in Service	
Customer Condition Code			V Function Group (VFG)	
Source System Program Type			Repair/Report/Paid Date	07-May-2004
Version Series Code	UNKN		Load Date	29-Nov-2007
Causal Part Prefix- Base - Suffix	-		Dealer Code	
Causal Part Name	NOT PROVIDED BY SOURCE		Dealer Name	NOT PROVIDED BY SOURCE
Non Causal Part Prefix-Base-Suffix			Dealer City	
Non Causal Part Numbers			Dealer State/Province	
Fault Code			Dealer Country	USA
Diagnostic Trouble Code			Dealer Phone Number	
Labor Operation Code			Attachment	
Communication Type			VOQ Component Description Code	
Maintenance Date	29-Nov-2007			

Customer Comment	PULLING INTO A PARKING SPOT AND THE CAR SURGED FORWARD AT A HIGH RATE. RESULTING IN \$2,206.79 IN DAMAGE THE DEALER SAID THAT IS NOT POSSIBLE AND SAID THAT HAS NEVER HAPPENED BEFORE. *L		
Technician Comment			
CQIS Recommendations			

Tire Information

Tire Manufacturer	Unknown	Tire Size	Unknown
Tire Brand Series		Wheel	
DOT Left Front		DOT Right Front	
DOT Left Rear		DOT Right Rear	
DOT Left Inner		DOT Right Inner	
DOT Spare			

Vehicle Information

VIN	*4F2CZ	Engine Serial Number	UNKNOWN
Model Year	2004	Engine Description	Unknown
Transmission	Unknown	Vehicle Description	TRIBUTE
Body Cab Style	UNKN Unknown	Drive Line	Unknown
Production Date		Retail Sale Indicator Code	
Plant Description	Unknown	Required Vehicle	
Build Region		Warranty Start Date	
Build Country Code		Transmission Serial Number	UNKNOWN
Mileage	5228	Vehicle Axle Ratio	
Vehicle Restraint Code			

Disclaimer:

This data is for use as one of several potential "awareness" indicators for the Ford Motor Co. Enhanced Concern Identification System. It is unverified, draft, summary data generated from a computer "word search" of customer and technician symptom comments. Supplier data, technician and customer comments are unverified and actual root cause of any potential issue is not established by this summary.

[Contact ODR Help](#)

PE12-019

MADZA

9/6/2012

APPENDIX 3 SUBJECT
VEHICLES

Consumer Reports

VOQ Mazda

ECI

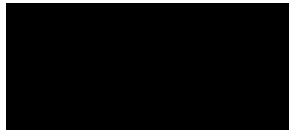



Concern Driven Reporting

Report Detail

Note: Field which are grayed (ghosted) are currently being mapped to the data warehouse. They are not presently being populated.

ECI Record		Source Code	VOQ Mazda
------------	--	-------------	-----------

Commodity Assignment

Commodity	powertrain-engine-accel pedal/linkage/controls	Symptom	mod-driving condition-at cruise
Commodity	powertrain-engine-accel pedal/linkage/controls	Symptom	mod-driving condition-on acceleration
Commodity	powertrain-engine-accel pedal/linkage/controls	Symptom	mod-driving condition-while driving
Commodity	powertrain-engine-accel pedal/linkage/controls	Symptom	mod-shift reverse
Commodity	powertrain-engine-accel pedal/linkage/controls	Symptom	unintended acceleration
Significant Event	Personal Injury; Property Damage;	Verified	N

Tread Information

Report Details

Source Claim Key		ODI 10103702	Warranty Component Classification (WCC)	
Corporate Product Systems Classification (CPSC)			Time in Service	
Customer Condition Code			V Function Group (VFG)	
Source System Program Type			Repair/Report/Paid Date	23-Nov-2004
Version Series Code	UNKN		Load Date	29-Nov-2007
Causal Part Prefix- Base - Suffix	-		Dealer Code	
Causal Part Name	NOT PROVIDED BY SOURCE		Dealer Name	NOT PROVIDED BY SOURCE
Non Causal Part Prefix-Base-Suffix			Dealer City	
Non Causal Part Numbers			Dealer State/Province	
Fault Code			Dealer Country	USA
Diagnostic Trouble Code			Dealer Phone Number	
Labor Operation Code			Attachment	
Communication Type			VOQ Component Description Code	
Maintenance Date	29-Nov-2007			

Customer Comment	WHILE BACKING OUT OF A PARKING SPACE THE BACK BUMPER SLIGHTLY BUMPED THE LIGHT POLE. WHEN THE CONSUMER SHIFTED THE VEHICLE INTO DRIVE IT COMMENCED TO ACCELERATE AT HIGH SPEED, LURCHED FORWARD AND RAN INTO A CENTER BLOCK WALL. NO INJURIES WERE REPORTED. THE INSURANCE COMPANY TOTALED THE VEHICLE, AND THEY NOTIFIED THE DEALER AND THE MANUFACTURER.*A
Technician Comment	
CQIS Recommendations	

Tire Information

Tire Manufacturer	Unknown	Tire Size	Unknown
Tire Brand Series		Wheel	
DOT Left Front		DOT Right Front	
DOT Left Rear		DOT Right Rear	
DOT Left Inner		DOT Right Inner	
DOT Spare			

Vehicle Information

VIN	*4F2CU	Engine Serial Number	UNKNOWN
Model Year	2002	Engine Description	Unknown
Transmission	Unknown	Vehicle Description	TRIBUTE
Body Cab Style	UNKN Unknown	Drive Line	Unknown
Production Date		Retail Sale Indicator Code	
Plant Description	Unknown	Required Vehicle	
Build Region		Warranty Start Date	
Build Country Code		Transmission Serial Number	UNKNOWN
Mileage	20000	Vehicle Axle Ratio	
Vehicle Restraint Code			

Disclaimer:

This data is for use as one of several potential "awareness" indicators for the Ford Motor Co. Enhanced Concern Identification System. It is unverified, draft, summary data generated from a computer "word search" of customer and technician symptom comments. Supplier data, technician and customer comments are unverified and actual root cause of any potential issue is not established by this summary.

[Contact ODRHELP](#)

Copyright 2001 Ford Motor Co All Rights Reserved

PE12-019

MADZA

9/6/2012

APPENDIX 3 SUBJECT
VEHICLES

Consumer Reports

VOQ Mazda

ECI 



Concern Driven Reporting

Report Detail

Note: Field which are grayed (ghosted) are currently being mapped to the data warehouse. They are not presently being populated.

ECI Record		Source Code	VOQ Mazda
------------	--	-------------	-----------

Commodity Assignment

Commodity	powertrain-engine-accel pedal/linkage/controls	Symptom	damage-burned component (not fire)
Commodity	powertrain-engine-accel pedal/linkage/controls	Symptom	function-malfunction/inoperative
Commodity	powertrain-engine-accel pedal/linkage/controls	Symptom	mod-driving condition-at cruise
Commodity	powertrain-engine-accel pedal/linkage/controls	Symptom	mod-driving condition-at idle
Commodity	powertrain-engine-accel pedal/linkage/controls	Symptom	mod-vehicle towed in
Commodity	powertrain-engine-accel pedal/linkage/controls	Symptom	pedal concerns-accelerator pedal
Commodity	powertrain-engine-accel pedal/linkage/controls	Symptom	repair-prior repair mentioned
Significant Event		Verified	N

Tread Information

Report Details

Source Claim Key		ODI 10103722	Warranty Component Classification (WCC)	
Corporate Product Systems Classification (CPSC)			Time in Service	
Customer Condition Code			V Function Group (VFG)	
Source System Program Type			Repair/Report/Paid Date	12-Dec-2004
Version Series Code	UNKN		Load Date	29-Nov-2007
Causal Part Prefix- Base - Suffix	- -		Dealer Code	
Causal Part Name	NOT PROVIDED BY SOURCE		Dealer Name	NOT PROVIDED BY SOURCE
Non Causal Part Prefix-Base-Suffix			Dealer City	
Non Causal Part Numbers			Dealer State/Province	
Fault Code			Dealer Country	USA
Diagonstic Trouble Code			Dealer Phone Number	
Labor Operation Code			Attachment	
Communication Type			VOQ Component Description Code	
Maintenance Date	29-Nov-2007			

Customer Comment WHILE DRIVING 40 MPH VEHICLE COMMENCED TO ACCELERATE. CONSUMER WAS ABLE TO DRIVE THE VEHICLE TO A SERVICE STATION. WHILE PARKED AND IDLING THE PROBLEM RECURRED. THIS TIME THE ACCELERATOR PEDAL WAS DOWN TO THE FLOOR. VEHICLE WAS TOWED TO THE DEALER, WHO INFORMED THE CONSUMER ACCELERATOR ASSEMBLY BURNED OUT AND NEEDED TO BE REPLACED.*AK

Technician Comment

CQIS Recommendations

Tire Information

Tire Manufacturer	Unknown	Tire Size	Unknown
Tire Brand Series		Wheel	
DOT Left Front		DOT Right Front	
DOT Left Rear		DOT Right Rear	
DOT Left Inner		DOT Right Inner	
DOT Spare			

Vehicle Information

VIN	*4F2CZ	Engine Serial Number	UNKNOWN
Model Year	2003	Engine Description	Unknown
Transmission	Unknown	Vehicle Description	TRIBUTE
Body Cab Style	UNKN Unknown	Drive Line	Unknown
Production Date		Retail Sale Indicator Code	
Plant Description	Unknown	Reaquired Vehicle	
Build Region		Warranty Start Date	12-Mar-2006
Build Country Code		Transmission Serial Number	UNKNOWN
Mileage	47000	Vehicle Axle Ratio	
Vehicle Restraint Code			

Disclaimer:

This data is for use as one of several potential "awareness" indicators for the Ford Motor Co. Enhanced Concern Identification System. It is unverified, draft, summary data generated from a computer "word search" of customer and technician symptom comments. Supplier data, technician and customer comments are unverified and actual root cause of any potential issue is not established by this summary.

[Contact ODRHELP](#)

Copyright 2001 Ford Motor Co All Rights Reserved

PE12-019

MADZA

9/6/2012

APPENDIX 3 SUBJECT
VEHICLES

Consumer Reports

VOQ Mazda

ECI

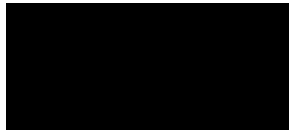



Concern Driven Reporting

Report Detail

Note: Field which are grayed (ghosted) are currently being mapped to the data warehouse. They are not presently being populated.

ECI Record		Source Code	VOQ Mazda
------------	--	-------------	-----------

Commodity Assignment

Commodity	powertrain-engine-accel pedal/linkage/controls	Symptom	field service action
Commodity	powertrain-engine-accel pedal/linkage/controls	Symptom	mod-driving condition-at cruise
Commodity	powertrain-engine-accel pedal/linkage/controls	Symptom	pedal concerns-accelerator pedal
Significant Event	Personal Injury; Property Damage;	Verified	N

Tread Information

Report Details

Source Claim Key		ODI 10111295	Warranty Component Classification (WCC)	
Corporate Product Systems Classification (CPSC)			Time in Service	
Customer Condition Code			V Function Group (VFG)	
Source System Program Type			Repair/Report/Paid Date	18-Jan-2005
Version Series Code	UNKN		Load Date	29-Nov-2007
Causal Part Prefix- Base - Suffix	-		Dealer Code	
Causal Part Name	NOT PROVIDED BY SOURCE		Dealer Name	NOT PROVIDED BY SOURCE
Non Causal Part Prefix-Base-Suffix			Dealer City	
Non Causal Part Numbers			Dealer State/Province	
Fault Code			Dealer Country	USA
Diagnostic Trouble Code			Dealer Phone Number	
Labor Operation Code			Attachment	
Communication Type			VOQ Component Description Code	
Maintenance Date	29-Nov-2007			

Customer Comment	WHILE DRIVING 40 MPH VEHICLE ACCELERATED. AS A RESULT, CONSUMER'S VEHICLE REAR ENDED ANOTHER VEHICLE. NO INJURIES REPORTED. CONSUMER STATED TWO WEEKS LATER A RECALL FOR THE ACCELERATOR PEDAL WAS ISSUED. *A
Technician Comment	
CQIS Recommendations	

Tire Information

Tire Manufacturer	Unknown	Tire Size	Unknown
Tire Brand Series		Wheel	
DOT Left Front		DOT Right Front	
DOT Left Rear		DOT Right Rear	
DOT Left Inner		DOT Right Inner	
DOT Spare			

Vehicle Information

VIN	*	Engine Serial Number	UNKNOWN
Model Year	2003	Engine Description	Unknown
Transmission	Unknown	Vehicle Description	TRIBUTE
Body Cab Style	UNKN Unknown	Drive Line	Unknown
Production Date		Retail Sale Indicator Code	
Plant Description	Unknown	Required Vehicle	
Build Region		Warranty Start Date	12-Mar-2006
Build Country Code		Transmission Serial Number	UNKNOWN
Mileage	20000	Vehicle Axle Ratio	
Vehicle Restraint Code			

Disclaimer:

This data is for use as one of several potential "awareness" indicators for the Ford Motor Co. Enhanced Concern Identification System. It is unverified, draft, summary data generated from a computer "word search" of customer and technician symptom comments. Supplier data, technician and customer comments are unverified and actual root cause of any potential issue is not established by this summary.

[Contact ODR Help](#)

PE12-019

MADZA

9/6/2012

APPENDIX 3 SUBJECT
VEHICLES

Consumer Reports

VOQ Mazda

ECI

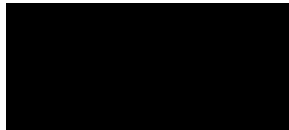



Concern Driven Reporting

Report Detail

Note: Field which are grayed (ghosted) are currently being mapped to the data warehouse. They are not presently being populated.

ECI Record		Source Code	VOQ Mazda
------------	--	-------------	-----------

Commodity Assignment			
Commodity	powertrain-engine-accel pedal/linkage/controls	Symptom	field service action
Commodity	powertrain-engine-accel pedal/linkage/controls	Symptom	function-malfunction/inoperative
Commodity	powertrain-engine-accel pedal/linkage/controls	Symptom	high effort
Commodity	powertrain-engine-accel pedal/linkage/controls	Symptom	mod-driving condition-at idle
Commodity	powertrain-engine-accel pedal/linkage/controls	Symptom	no problem found
Commodity	powertrain-engine-accel pedal/linkage/controls	Symptom	pedal concerns-accelerator pedal
Commodity	powertrain-engine-accel pedal/linkage/controls	Symptom	pedal concerns-pedal positions
Commodity	powertrain-engine-accel pedal/linkage/controls	Symptom	pressure-low
Significant Event		Verified	N

Tread Information

Report Details

Source Claim Key		ODI T0104559	Warranty Component Classification (WCC)	
Corporate Product Systems Classification (CPSC)			Time in Service	
Customer Condition Code			V Function Group (VFG)	
Source System Program Type			Repair/Report/Paid Date	04-Nov-2004
Version Series Code	UNKN		Load Date	29-Nov-2007
Causal Part Prefix- Base - Suffix	-		Dealer Code	
Causal Part Name	NOT PROVIDED BY SOURCE		Dealer Name	NOT PROVIDED BY SOURCE
Non Causal Part Prefix-Base-Suffix			Dealer City	
Non Causal Part Numbers			Dealer State/Province	
Fault Code			Dealer Country	USA
Diagnostic Trouble Code			Dealer Phone Number	
Labor Operation Code			Attachment	
Communication Type			VOQ Component Description Code	
Maintenance Date	29-Nov-2007			

Customer Comment	ACCELLATOR PEDAL IS HARDER TO PRESS DOWN, THEN IT WAS 15,000 MILES AGO. IT DOES RETURN TO A PROPER IDLE SPEED AT THIS TIME. PER MAZDA SERVICE DEPARTMENT TECH, THE THROTTLE BODY COLLECTS A SOOT, OR OILY EXHAUST OVER TIME, CAUSING THE THROTTLE BODY BUTTERFLY VALVE TO NOT MOVE FREELY. THE CAUSE OF THIS CONDITION IN MAZDA TRIBUTE AND IN FORD ESCAPES IS A POOR DESIGN OF THE ENTRANCE OF EXHAUST GASSES TO BE REBURNED. THE EXHAUST GASSES ARE RETURNED JUST IN BACK OF THE THROTTLE BODY, THEREBY CAUSING THE BUILDUP AND POSSIBLE MALFUNCTION OF THE THROTTLE BODY IN THE OPEN POSITION. RECALL CAMPAIGN NUMBER 04V583000 DOES NOT COVER THIS PROBLEM, AS IT COVERS THE VEHICLE SPEED CONTROL CABLES.*A		
Technician Comment			
CQIS Recommendations			

Tire Information

Tire Manufacturer	Unknown	Tire Size	Unknown
Tire Brand Series		Wheel	
DOT Left Front		DOT Right Front	
DOT Left Rear		DOT Right Rear	
DOT Left Inner		DOT Right Inner	
DOT Spare			

Vehicle Information

VIN	*4F2CZ	Engine Serial Number	UNKNOWN
Model Year	2003	Engine Description	Unknown
Transmission	Unknown	Vehicle Description	TRIBUTE
Body Cab Style	UNKN Unknown	Drive Line	Unknown
Production Date		Retail Sale Indicator Code	
Plant Description	Unknown	Required Vehicle	
Build Region		Warranty Start Date	12-Mar-2006
Build Country Code		Transmission Serial Number	UNKNOWN
Mileage	28000	Vehicle Axle Ratio	
Vehicle Restraint Code			

Disclaimer:

This data is for use as one of several potential "awareness" indicators for the Ford Motor Co. Enhanced Concern Identification System. It is unverified, draft, summary data generated from a computer "word search" of customer and technician symptom comments. Supplier data, technician and customer comments are unverified and actual root cause of any potential issue is not established by this summary.

[Contact ODRHELP](#)

Copyright 2001 Ford Motor Co All Rights Reserved

PE12-019

MADZA

9/6/2012

APPENDIX 3 SUBJECT
VEHICLES

Consumer Reports

VOQ Mazda

ECI

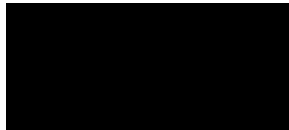



Concern Driven Reporting

Report Detail

Note: Field which are grayed (ghosted) are currently being mapped to the data warehouse. They are not presently being populated.

ECI Record		Source Code	VOQ Mazda
------------	--	-------------	-----------

Commodity Assignment

Commodity	powertrain-engine-accel pedal/linkage/controls	Symptom	field service action
Commodity	powertrain-engine-accel pedal/linkage/controls	Symptom	pedal concerns-accelerator pedal
Commodity	powertrain-engine-accel pedal/linkage/controls	Symptom	sticks/binds/grabs
Significant Event	Personal Injury; Property Damage;	Verified	N

Tread Information

Report Details

Source Claim Key		ODI 10111725	Warranty Component Classification (WCC)	
Corporate Product Systems Classification (CPSC)			Time in Service	
Customer Condition Code			V Function Group (VFG)	
Source System Program Type			Repair/Report/Paid Date	09-Feb-2005
Version Series Code	UNKN		Load Date	29-Nov-2007
Causal Part Prefix- Base - Suffix	-		Dealer Code	
Causal Part Name	NOT PROVIDED BY SOURCE		Dealer Name	NOT PROVIDED BY SOURCE
Non Causal Part Prefix-Base-Suffix			Dealer City	
Non Causal Part Numbers			Dealer State/Province	
Fault Code			Dealer Country	USA
Diagnostic Trouble Code			Dealer Phone Number	
Labor Operation Code			Attachment	
Communication Type			VOQ Component Description Code	
Maintenance Date	29-Nov-2007			

Customer Comment	WHILE DRIVING THE VEHICLE, THE ACCELERATOR STUCK. THE CONSUMER PULLED OFF THE ROAD DUE TO HEAVY FOG BUT THE VEHICLE WENT INTO THE LAKE. *NM RECALL CAMPAIGN# 04V583000. *SC *J
Technician Comment	
C Q I S Recommendations	

Tire Information

Tire Manufacturer	Unknown	Tire Size	Unknown
Tire Brand Series		Wheel	
DOT Left Front		DOT Right Front	
DOT Left Rear		DOT Right Rear	
DOT Left Inner		DOT Right Inner	
DOT Spare			

Vehicle Information

VIN	*4F2YZ	Engine Serial Number	UNKNOWN
Model Year	2003	Engine Description	Unknown
Transmission	Unknown	Vehicle Description	TRIBUTE
Body Cab Style	UNKN Unknown	Drive Line	Unknown
Production Date		Retail Sale Indicator Code	
Plant Description	Unknown	Required Vehicle	
Build Region		Warranty Start Date	12-Mar-2006
Build Country Code		Transmission Serial Number	UNKNOWN
Mileage	32655	Vehicle Axle Ratio	
Vehicle Restraint Code			

Disclaimer:

This data is for use as one of several potential "awareness" indicators for the Ford Motor Co. Enhanced Concern Identification System. It is unverified, draft, summary data generated from a computer "word search" of customer and technician symptom comments. Supplier data, technician and customer comments are unverified and actual root cause of any potential issue is not established by this summary.

[Contact ODR Help](#)

PE12-019

MADZA

9/6/2012

APPENDIX 3 SUBJECT
VEHICLES

Consumer Reports

VOQ Mazda

ECI

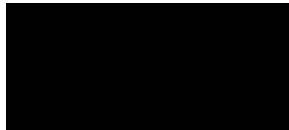



Concern Driven Reporting

Report Detail

Note: Field which are grayed (ghosted) are currently being mapped to the data warehouse. They are not presently being populated.

ECI Record		Source Code	VOQ Mazda
------------	--	-------------	-----------

Commodity Assignment			
Commodity	powertrain-engine-accel pedal/linkage/controls	Symptom	mod-driving condition-at idle
Commodity	powertrain-engine-accel pedal/linkage/controls	Symptom	mod-driving condition-at start up
Commodity	powertrain-engine-accel pedal/linkage/controls	Symptom	mod-driving condition-engine-hot
Commodity	powertrain-engine-accel pedal/linkage/controls	Symptom	mod-intermittent/random
Commodity	powertrain-engine-accel pedal/linkage/controls	Symptom	pedal concerns-accelerator pedal
Commodity	powertrain-engine-accel pedal/linkage/controls	Symptom	pedal concerns-pedal positions
Commodity	powertrain-engine-accel pedal/linkage/controls	Symptom	sticks/binds/grabs
Significant Event		Verified	N

Tread Information

Report Details

Source Claim Key		ODI 10106829	Warranty Component Classification (WCC)	
Corporate Product Systems Classification (CPSC)			Time in Service	
Customer Condition Code			V Function Group (VFG)	
Source System Program Type			Repair/Report/Paid Date	25-Sep-2004
Version Series Code	UNKN		Load Date	29-Nov-2007
Causal Part Prefix- Base - Suffix	- -		Dealer Code	
Causal Part Name	NOT PROVIDED BY SOURCE		Dealer Name	NOT PROVIDED BY SOURCE
Non Causal Part Prefix-Base-Suffix			Dealer City	
Non Causal Part Numbers			Dealer State/Province	
Fault Code			Dealer Country	USA
Diagonstic Trouble Code			Dealer Phone Number	
Labor Operation Code			Attachment	
Communication lype			VOQ Component Description Code	
Maintenance Date	29-Nov-2007			

Customer Comment	ACCELERATOR PEDAL GETS STUCK IN IDLE POSITION. BY APPLYING FORCE, THEN ACCELERATOR PEDAL MOVES BUT VEHICLE TAKES OFF ERRATICALLY. IT HAPPENS WHEN ENGINE IS COLD AND HOT. *A		
Technician Comment			
C Q I S Recommendations			

Tire Information

Tire Manufacturer	Unknown	Tire Size	Unknown
Tire Brand Series		Wheel	
DOT Left Front		DOT Right Front	
DOT Left Rear		DOT Right Rear	
DOT Left Inner		DOT Right Inner	
DOT Spare			

Vehicle Information

VIN	*4F2C2	Engine Serial Number	UNKNOWN
Model Year	2003	Engine Description	Unknown
Transmission	Unknown	Vehicle Description	TRIBUTE
Body Cab Style	UNKN Unknown	Drive Line	Unknown
Production Date		Retail Sale Indicator Code	
Plant Description	Unknown	Reaquired Vehicle	
Build Region		Warranty Start Date	12-Mar-2006
Build Country Code		Transmission Serial Number	UNKNOWN
Mileage	0	Vehicle Axle Ratio	
Vehicle Restraint Code			

Disclaimer:

This data is for use as one of several potential "awareness" indicators for the Ford Motor Co. Enhanced Concern Identification System. It is unverified, draft, summary data generated from a computer "word search" of customer and technician symptom comments. Supplier data, technician and customer comments are unverified and actual root cause of any potential issue is not established by this summary.

[Contact ODRHELP](#)

Copyright 2001 Ford Motor Co All Rights Reserved

PE12-019

MADZA

9/6/2012

APPENDIX 3 SUBJECT
VEHICLES

Consumer Reports

VOQ Mazda

ECI

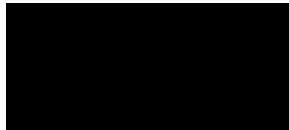



Concern Driven Reporting

Report Detail

Note: Field which are grayed (ghosted) are currently being mapped to the data warehouse. They are not presently being populated.

ECI Record		Source Code	VOQ Mazda
------------	--	-------------	-----------

Commodity Assignment

Commodity	powertrain-engine-accel pedal/linkage/controls	Symptom	function-malfunction/inoperative
Commodity	powertrain-engine-accel pedal/linkage/controls	Symptom	mod-driving condition-on deceleration/braking
Commodity	powertrain-engine-accel pedal/linkage/controls	Symptom	mod-driving condition-while driving
Commodity	powertrain-engine-accel pedal/linkage/controls	Symptom	mod-vehicle towed in
Commodity	powertrain-engine-accel pedal/linkage/controls	Symptom	sticks/binds/grabs
Significant Event		Verified	N

Tread Information

Report Details

Source Claim Key		ODI 10107624	Warranty Component Classification (WCC)	
Corporate Product Systems Classification (CPSC)			Time in Service	
Customer Condition Code			V Function Group (VFG)	
Source System Program Type			Repair/Report/Paid Date	17-Dec-2004
Version Series Code	UNKN		Load Date	29-Nov-2007
Causal Part Prefix- Base - Suffix	-		Dealer Code	
Causal Part Name	NOT PROVIDED BY SOURCE		Dealer Name	NOT PROVIDED BY SOURCE
Non Causal Part Prefix-Base-Suffix			Dealer City	
Non Causal Part Numbers			Dealer State/Province	
Fault Code			Dealer Country	USA
Diagnostic Trouble Code			Dealer Phone Number	
Labor Operation Code			Attachment	
Communication Type			VOQ Component Description Code	
Maintenance Date	29-Nov-2007			

Customer Comment	2005 MAZDA TRIBUTE [4000 MI] BRAKES FAILED AND THROTTLE STUCK ON DEC 17, 2004. I HAD TO PULL HAND BRAKE TO STOP CAR WAS TOWED TO DEALERSHIP IN AMHERST VA. THROTTLE ASSY, IDLE CONTROL VALVE AND A 100MI ROAD TEST WERE DONE. PICKED VEHICLE UP ON JAN 14,2005. ON JAN 15TH, PROBLEM OCCURRED AGAIN WITH BRAKES NON RESPONSIVE AND THROTTLE STUCK. SOMEONE ELSE WAS DRIVING AND THEY TURNED ENGINE OFF AND COASTED OFF THE ROAD. VEHICLE WAS TOWED BACK TO DEALERSHIP IN AMHERST AND REMAINS THERE AT PRESENT		
Technician Comment			
CQIS Recommendations			

Tire Information

Tire Manufacturer	Unknown	Tire Size	Unknown
Tire Brand Series		Wheel	
DOT Left Front		DOT Right Front	
DOT Left Rear		DOT Right Rear	
DOT Left Inner		DOT Right Inner	
DOT Spare			

Vehicle Information

VIN	*4F2YZ	Engine Serial Number	UNKNOWN
Model Year	2005	Engine Description	Unknown
Transmission	Unknown	Vehicle Description	TRIBUTE
Body Cab Style	UNKN Unknown	Drive Line	Unknown
Production Date		Retail Sale Indicator Code	
Plant Description	Unknown	Reaquired Vehicle	
Build Region		Warranty Start Date	
Build Country Code		Transmission Serial Number	UNKNOWN
Mileage	4000	Vehicle Axle Ratio	
Vehicle Restraint Code			

Disclaimer:

This data is for use as one of several potential "awareness" indicators for the Ford Motor Co. Enhanced Concern Identification System. It is unverified, draft, summary data generated from a computer "word search" of customer and technician symptom comments. Supplier data, technician and customer comments are unverified and actual root cause of any potential issue is not established by this summary.

[Contact ODRHELP](#)

Copyright 2001 Ford Motor Co All Rights Reserved

PE12-019

MADZA

9/6/2012

APPENDIX 3 SUBJECT
VEHICLES

Consumer Reports

VOQ Mazda

ECI

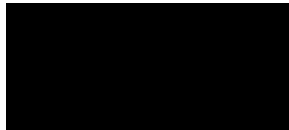



Concern Driven Reporting

Report Detail

Note: Field which are grayed (ghosted) are currently being mapped to the data warehouse. They are not presently being populated.

ECI Record		Source Code	VOQ Mazda
------------	--	-------------	-----------

Commodity Assignment			
Commodity	powertrain-engine-accel pedal/linkage/controls	Symptom	damage-cracked/fractured/split
Commodity	powertrain-engine-accel pedal/linkage/controls	Symptom	damage-cut/torn/frayed
Commodity	powertrain-engine-accel pedal/linkage/controls	Symptom	field service action
Commodity	powertrain-engine-accel pedal/linkage/controls	Symptom	function-malfunction/inoperative
Commodity	powertrain-engine-accel pedal/linkage/controls	Symptom	loss of control
Commodity	powertrain-engine-accel pedal/linkage/controls	Symptom	mod-vehicle towed in
Commodity	powertrain-engine-accel pedal/linkage/controls	Symptom	pedal concerns-accelerator pedal
Commodity	powertrain-engine-accel pedal/linkage/controls	Symptom	repair-prior repair mentioned
Commodity	powertrain-engine-accel pedal/linkage/controls	Symptom	separation
Significant Event	Personal Injury, Property Damage,	Verified	N

Tread Information

Report Details

Source Claim Key		ODI 10108769	Warranty Component Classification (WCC)	
Corporate Product Systems Classification (CPS)			Time in Service	
Customer Condition Code			V Function Group (VFG)	
Source System Program Type			Repair/Report/Paid Date	22-Jan-2005
Version Series Code	UNKN		Load Date	29-Nov-2007
Causal Part Prefix-Base-Suffix	-		Dealer Code	
Causal Part Name	NOT PROVIDED BY SOURCE		Dealer Name	NOT PROVIDED BY SOURCE
Non Causal Part Prefix-Base-Suffix			Dealer City	
Non Causal Part Numbers			Dealer State/Province	
Fault Code			Dealer Country	USA
Diagnostic Trouble Code			Dealer Phone Number	
Labor Operation Code			Attachment	
Communication Type			VOQ Component Description Code	
Maintenance Date	29-Nov-2007			

Customer Comment	NHTSA RECALL 04V583000 ON THE ACCELERATOR CABLE. APPROXIMATELY TWO YEARS AFTER HAVING THE ACCELERATOR CABLE REPLACED THE PROBLEM RECCURED. WHILE DRIVING 2 MPH, THE VEHICLE ACCELERATED UNCONTROLLABLY. THE DRIVER APPLIED THE BRAKE PEDAL AND THE VEHICLE CONTINUED TO ACCELERATE. THE DRIVER WAS NOT ABLE TO MAINTAIN CONTROL OF THE VEHICLE AND COLLIDED INTO A LIGHT POLE. THIS CAUSED THE DRIVER TO SUSTAIN MINOR INJURIES AND WAS TAKEN TO THE HOSPITAL. THE VEHICLE WAS TOWED TO A DEALER FOR INSPECTION. *JB THE BATTERY WAS INOPERATIVE DUE TO A BROKEN CABLE AND A FRAYED MAIN BELT HAD COME OFF AND THE STEERING WAS IMPAIRED. *SC *J		
Technician Comment			
CQIS Recommendations			

Tire Information

Tire Manufacturer	Unknown	Tire Size	Unknown
Tire Brand Series		Wheel	
DOT Left Front		DOT Right Front	
DOT Left Rear		DOT Right Rear	
DOT Left Inner		DOT Right Inner	
DOT Spare			

Vehicle Information

VIN	*4S2YC	Engine Serial Number	UNKNOWN
Model Year	2002	Engine Description	Unknown
Transmission	Unknown	Vehicle Description	TRIBUTE
Body Cab Style	UNKN Unknown	Drive Line	Unknown
Production Date		Retail Sale Indicator Code	
Plant Description	Unknown	Required Vehicle	
Build Region		Warranty Start Date	
Build Country Code		Transmission Serial Number	UNKNOWN
Mileage	27095	Vehicle Axle Ratio	
Vehicle Restraint Code			

Disclaimer:

This data is for use as one of several potential "awareness" indicators for the Ford Motor Co. Enhanced Concern Identification System. It is unverified, draft, summary data generated from a computer "word search" of customer and technician symptom comments. Supplier data, technician and customer comments are unverified and actual root cause of any potential issue is not established by this summary.

[Contact ODRHELP](#)

Copyright 2001 Ford Motor Co All Rights Reserved

PE12-019

MADZA

9/6/2012

APPENDIX 3 SUBJECT
VEHICLES

Consumer Reports

VOQ Mazda

ECI

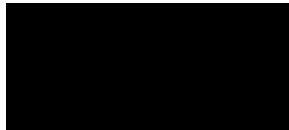



Concern Driven Reporting

Report Detail

Note: Field which are grayed (ghosted) are currently being mapped to the data warehouse. They are not presently being populated.

ECI Record		Source Code	VOQ Mazda
------------	--	-------------	-----------

Commodity Assignment			
Commodity	powertrain-engine-accel pedal/linkage/controls	Symptom	engine rpm surge/flare
Commodity	powertrain-engine-accel pedal/linkage/controls	Symptom	field service action
Commodity	powertrain-engine-accel pedal/linkage/controls	Symptom	high effort
Commodity	powertrain-engine-accel pedal/linkage/controls	Symptom	mod-driving condition-on acceleration
Commodity	powertrain-engine-accel pedal/linkage/controls	Symptom	mod-driving condition-while driving
Commodity	powertrain-engine-accel pedal/linkage/controls	Symptom	pedal concerns-accelerator pedal
Significant Event		Verified	N

Tread Information

Report Details

Source Claim Key		ODI 10114903	Warranty Component Classification (WCC)	
Corporate Product Systems Classification (CPSC)			Time in Service	
Customer Condition Code			V Function Group (VFG)	
Source System Program Type			Repair/Report/Paid Date	01-Mar-2005
Version Series Code	UNKN		Load Date	29-Nov-2007
Causal Part Prefix-Base-Suffix	-		Dealer Code	
Causal Part Name	NOT PROVIDED BY SOURCE		Dealer Name	NOT PROVIDED BY SOURCE
Non Causal Part Prefix-Base-Suffix			Dealer City	
Non Causal Part Numbers			Dealer State/Province	
Fault Code			Dealer Country	USA
Diagnostic Trouble Code			Dealer Phone Number	
Labor Operation Code			Attachment	
Communication Type			VOQ Component Description Code	
Maintenance Date	29-Nov-2007			

Customer Comment	THE CONSUMER NOTICED THAT THE GAS PEDAL ON HIS 2001 MAZDA TRIBUTE HAS BECOME HARDER TO DEPRESS AND THE ENGINE JUMPS WHEN THE VEHICLE ACCELERATES. *NM THE CONSUMER WANTS TO KNOW IF RECALL 04V574000 APPLIES TO HIS VEHICLE, BECAUSE A RECALL WAS ISSUED ON THE 2003 FORD ESCAPE AND FORD ALSO MADE THE MAZDA TRIBUTE. *SC *J
Technician Comment	
CQIS Recommendations	

Tire Information

Tire Manufacturer	Unknown	Tire Size	Unknown
Tire Brand Series		Wheel	
DOT Left Front		DOT Right Front	
DOT Left Rear		DOT Right Rear	
DOT Left Inner		DOT Right Inner	
DOT Spare			

Vehicle Information

VIN	*4F2CU	Engine Serial Number	UNKNOWN
Model Year	2001	Engine Description	Unknown
Transmission	Unknown	Vehicle Description	TRIBUTE
Body Cab Style	UNKN Unknown	Drive Line	Unknown
Production Date		Retail Sale Indicator Code	
Plant Description	Unknown	Reaquired Vehicle	
Build Region		Warranty Start Date	
Build Country Code		Transmission Serial Number	UNKNOWN
Mileage	0	Vehicle Axle Ratio	
Vehicle Restraint Code			

Disclaimer:

This data is for use as one of several potential "awareness" indicators for the Ford Motor Co. Enhanced Concern Identification System. It is unverified, draft, summary data generated from a computer "word search" of customer and technician symptom comments. Supplier data, technician and customer comments are unverified and actual root cause of any potential issue is not established by this summary.

[Contact ODRHELP](#)

Copyright 2001 Ford Motor Co All Rights Reserved

PE12-019

MADZA

9/6/2012

APPENDIX 3 SUBJECT
VEHICLES

Consumer Reports

VOQ Mazda

ECI

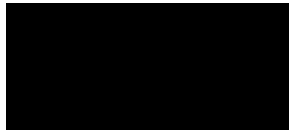

Disclaimer:

This data is for use as one of several potential "awareness" indicators for the Ford Motor Co. Enhanced Concern Identification System. It is unverified, draft, summary data generated from a computer "word search" of customer and technician symptom comments. Supplier data, technician and customer comments are unverified and actual root cause of any potential issue is not established by this summary.

[Contact ODRHELP](#)

Copyright 2001 Ford Motor Co All Rights Reserved

PE12-019

MADZA

9/6/2012

APPENDIX 3 SUBJECT
VEHICLES

Consumer Reports

VOQ Mazda

ECI

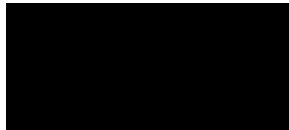



Concern Driven Reporting

Report Detail

Note: Field which are grayed (ghosted) are currently being mapped to the data warehouse. They are not presently being populated.

ECI Record		Source Code	VOQ Mazda
------------	--	-------------	-----------

Commodity Assignment			
Commodity	powertrain-engine-accel pedal/linkage/controls	Symptom	field service action
Commodity	powertrain-engine-accel pedal/linkage/controls	Symptom	mod-weather-cold
Commodity	powertrain-engine-accel pedal/linkage/controls	Symptom	no problem found
Commodity	powertrain-engine-accel pedal/linkage/controls	Symptom	pedal concerns-accelerator pedal
Commodity	powertrain-engine-accel pedal/linkage/controls	Symptom	sticks/binds/grabs
Significant Event	Property Damage;	Verified	N

Tread Information

Report Details

Source Claim Key		ODI I0119596	Warranty Component Classification (WCC)	
Corporate Product Systems Classification (CPSC)			Time in Service	
Customer Condition Code			V Function Group (VFG)	
Source System Program Type			Repair/Report/Paid Date	05-Dec-2003
Version Series Code	UNKN		Load Date	29-Nov-2007
Causal Part Prefix- Base - Suffix	-		Dealer Code	
Causal Part Name	NOT PROVIDED BY SOURCE		Dealer Name	NOT PROVIDED BY SOURCE
Non Causal Part Prefix-Base-Suffix			Dealer City	
Non Causal Part Numbers			Dealer State/Province	
Fault Code			Dealer Country	USA
Diagnostic Trouble Code			Dealer Phone Number	
Labor Operation Code			Attachment	
Communication Type			VOQ Component Description Code	
Maintenance Date	29-Nov-2007			

Customer Comment	CONTACT STATES THE ACCELERATOR IS STICKING. RECEIVED A RECALL LETTER, AND TOOK THE LETTER TO THE DEALER, WHO DID NOT FIX THE PROBLEM. ACCELERATOR STICKS MAINLY IN THE WINTER...WHEN TAKING FOOT OFF THE PEDAL FOR A FEW SECONDS AND TRYING TO HIT THE ACCELERATOR AGAIN VEHICLE SPEEDS UP AND IT JUMPS. *AK *J		
Technician Comment			
CQIS Recommendations			

Tire Information

Tire Manufacturer	Unknown	Tire Size	Unknown
Tire Brand Series		Wheel	
DOT Left Front		DOT Right Front	
DOT Left Rear		DOT Right Rear	
DOT Left Inner		DOT Right Inner	
DOT Spare			

Vehicle Information

VIN	*4F2YU	Engine Serial Number	UNKNOWN
Model Year	2002	Engine Description	Unknown
Transmission	Unknown	Vehicle Description	TRIBUTE
Body Cab Style	UNKN Unknown	Drive Line	Unknown
Production Date		Retail Sale Indicator Code	
Plant Description	Unknown	Required Vehicle	
Build Region		Warranty Start Date	
Build Country Code		Transmission Serial Number	UNKNOWN
Mileage	6000	Vehicle Axle Ratio	
Vehicle Restraint Code			

Disclaimer:

This data is for use as one of several potential "awareness" indicators for the Ford Motor Co. Enhanced Concern Identification System. It is unverified, draft, summary data generated from a computer "word search" of customer and technician symptom comments. Supplier data, technician and customer comments are unverified and actual root cause of any potential issue is not established by this summary.

[Contact ODRHELP](#)

Copyright 2001 Ford Motor Co All Rights Reserved

PE12-019

MADZA

9/6/2012

APPENDIX 3 SUBJECT
VEHICLES

Consumer Reports

VOQ Mazda

ECI

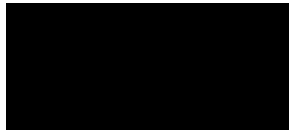



Concern Driven Reporting

Report Detail

Note: Field which are grayed (ghosted) are currently being mapped to the data warehouse. They are not presently being populated.

ECI Record		Source Code	VOQ Mazda
------------	--	-------------	-----------

Commodity Assignment

Commodity	powertrain-engine-accel pedal/linkage/controls	Symptom	mod-no indication (sudden)
Commodity	powertrain-engine-accel pedal/linkage/controls	Symptom	pedal concerns-accelerator pedal
Commodity	powertrain-engine-accel pedal/linkage/controls	Symptom	sticks/binds/grabs
Significant Event	Personal Injury; Property Damage;	Verified	N

Tread Information

Report Details

Source Claim Key		ODI 10119157	Warranty Component Classification (WCC)	
Corporate Product Systems Classification (CPSC)			Time in Service	
Customer Condition Code			V Function Group (VFG)	
Source System Program Type			Repair/Report/Paid Date	01-Dec-2004
Version Series Code	UNKN		Load Date	29-Nov-2007
Causal Part Prefix- Base - Suffix	-		Dealer Code	
Causal Part Name	NOT PROVIDED BY SOURCE		Dealer Name	NOT PROVIDED BY SOURCE
Non Causal Part Prefix-Base-Suffix			Dealer City	
Non Causal Part Numbers			Dealer State/Province	
Fault Code			Dealer Country	USA
Diagnostic Trouble Code			Dealer Phone Number	
Labor Operation Code			Attachment	
Communication Type			VOQ Component Description Code	
Maintenance Date	29-Nov-2007			

Customer Comment	ACCIDENT INVOLVING MAZDA TRIBUTE WHEREIN THE ACCELERATOR BECAME STUCK.*MR THE ATTORNEY REQUEST INFORMATION ON BEHALF OF CLIENT WHO WAS INJURED WHEN HER VEHICLE ACCELERATED SUDDENLY. THE VEHICLE WAS TOTALED. *N
Technician Comment	
CQIS Recommendations	

Tire Information

Tire Manufacturer	Unknown	Tire Size	Unknown
Tire Brand Series		Wheel	
DOT Left Front		DOT Right Front	
DOT Left Rear		DOT Right Rear	
DOT Left Inner		DOT Right Inner	
DOT Spare			

Vehicle Information

VIN	*4F2Y2	Engine Serial Number	UNKNOWN
Model Year	2003	Engine Description	Unknown
Transmission	Unknown	Vehicle Description	TRIBUTE
Body Cab Style	UNKN Unknown	Drive Line	Unknown
Production Date		Retail Sale Indicator Code	
Plant Description	Unknown	Reaquired Vehicle	
Build Region		Warranty Start Date	12-Mar-2006
Build Country Code		Transmission Serial Number	UNKNOWN
Mileage	0	Vehicle Axle Ratio	
Vehicle Restraint Code			

Disclaimer:

This data is for use as one of several potential "awareness" indicators for the Ford Motor Co. Enhanced Concern Identification System. It is unverified, draft, summary data generated from a computer "word search" of customer and technician symptom comments. Supplier data, technician and customer comments are unverified and actual root cause of any potential issue is not established by this summary.

PE12-019

MADZA

9/6/2012

APPENDIX 3 SUBJECT
VEHICLES

Consumer Reports

VOQ Mazda

ECI

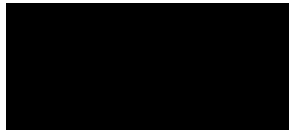



Concern Driven Reporting

Report Detail

Note: Field which are grayed (ghosted) are currently being mapped to the data warehouse. They are not presently being populated.

ECI Record		Source Code	VOQ Mazda
------------	--	-------------	-----------

Commodity Assignment			
Commodity	powertrain-engine-accel pedal/linkage/controls	Symptom	damage
Commodity	powertrain-engine-accel pedal/linkage/controls	Symptom	function-malfunction/inoperative
Commodity	powertrain-engine-accel pedal/linkage/controls	Symptom	function-stays on
Commodity	powertrain-engine-accel pedal/linkage/controls	Symptom	mod-driving condition-at cruise
Commodity	powertrain-engine-accel pedal/linkage/controls	Symptom	mod-driving condition-on acceleration
Commodity	powertrain-engine-accel pedal/linkage/controls	Symptom	mod-driving condition-while driving
Commodity	powertrain-engine-accel pedal/linkage/controls	Symptom	mod-no indication (sudden)
Significant Event	Property Damage;	Verified	N

Tread Information

Report Details

Source Claim Key		ODI 10119300	Warranty Component Classification (WCC)	
Corporate Product Systems Classification (CPSC)			Time in Service	
Customer Condition Code			V Function Group (VFG)	
Source System Program Type			Repair/Report/Paid Date	01-Apr-2005
Version Series Code	UNKN		Load Date	29-Nov-2007
Causal Part Prefix- Base - Suffix	- -		Dealer Code	
Causal Part Name	NOT PROVIDED BY SOURCE		Dealer Name	NOT PROVIDED BY SOURCE
Non Causal Part Prefix-Base-Suffix			Dealer City	
Non Causal Part Numbers			Dealer State/Province	
Fault Code			Dealer Country	USA
Diagonstic Trouble Code			Dealer Phone Number	
Labor Operation Code			Attachment	
Communication Type			VOQ Component Description Code	
Maintenance Date	29-Nov-2007			

Customer Comment	2004 MAZDA TRIBUTE EXPERIENCING PROBLEMS WITH SUDDEN ACCELERATION. *MR THERE WERE TWO OCCASIONS WHEN THE CONSUMER APPLIED THE BRAKES BUT THE VEHICLE DID NOT STOP. ONE OCCASION THE VEHICLE WAS PULLING UP TO A BUILDING AND DAMAGED THE FRONT END OF THE VEHICLE AND ON THE SECOND OCCASION, THE CONSUMER WAS TRAVELING ON THE HIGHWAY WHEN THE VEHICLE SUDDENLY ACCELERATED WITHOUT INCIDENT. *SC *J		
Technician Comment			
CQIS Recommendations			

Tire Information

Tire Manufacturer	Unknown	Tire Size	Unknown
Tire Brand Series		Wheel	
DOT Left Front		DOT Right Front	
DOT Left Rear		DOT Right Rear	
DOT Left Inner		DOT Right Inner	
DOT Spare			

Vehicle Information

VIN	*4F2CZ	Engine Serial Number	UNKNOWN
Model Year	2004	Engine Description	Unknown
Transmission	Unknown	Vehicle Description	TRIBUTE
Body Cab Style	UNKN Unknown	Drive Line	Unknown
Production Date		Retail Sale Indicator Code	
Plant Description	Unknown	Reaquired Vehicle	
Build Region		Warranty Start Date	
Build Country Code		Transmission Serial Number	UNKNOWN
Mileage	0	Vehicle Axle Ratio	
Vehicle Restraint Code			

Disclaimer:

This data is for use as one of several potential "awareness" indicators for the Ford Motor Co. Enhanced Concern Identification System. It is unverified, draft, summary data generated from a computer "word search" of customer and technician symptom comments. Supplier data, technician and customer comments are unverified and actual root cause of any potential issue is not established by this summary.

[Contact ODRHELP](#)

Copyright 2001 Ford Motor Co All Rights Reserved

PE12-019

MADZA

9/6/2012

APPENDIX 3 SUBJECT
VEHICLES

Consumer Reports

VOQ Mazda

ECI

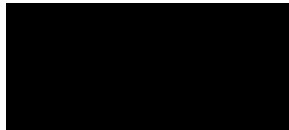



Concern Driven Reporting

Report Detail

Note: Field which are grayed (ghosted) are currently being mapped to the data warehouse. They are not presently being populated.

ECI Record		Source Code	VOQ Mazda
------------	--	-------------	-----------

Commodity Assignment			
Commodity	powertrain-engine-accel	pedal/linkage/controls	Symptom
			engine rpm surge/flare
Commodity	powertrain-engine-accel	pedal/linkage/controls	Symptom
			function-malfunction/inoperative
Commodity	powertrain-engine-accel	pedal/linkage/controls	Symptom
			function-stays on
Commodity	powertrain-engine-accel	pedal/linkage/controls	Symptom
			mod-driving condition-at idle
Commodity	powertrain-engine-accel	pedal/linkage/controls	Symptom
			mod-driving condition-on acceleration
Commodity	powertrain-engine-accel	pedal/linkage/controls	Symptom
			mod-driving condition-when engine running
Commodity	powertrain-engine-accel	pedal/linkage/controls	Symptom
			mod-driving condition-when engine/ignition turned off
Commodity	powertrain-engine-accel	pedal/linkage/controls	Symptom
			mod-intermittent/random
Significant Event		Verified	N

Tread Information

Report Details

Source Claim Key		ODI 10125132	Warranty Component Classification (WCC)	
Corporate Product Systems Classification (CPSC)			Time in Service	
Customer Condition Code			V Function Group (VFG)	
Source System Program Type			Repair/Report/Paid Date	10-Jun-2005
Version Series Code	UNKN		Load Date	29-Nov-2007
Causal Part Prefix - Base - Suffix	- -		Dealer Code	
Causal Part Name	NOT PROVIDED BY SOURCE		Dealer Name	NOT PROVIDED BY SOURCE
Non Causal Part Prefix-Base-Suffix			Dealer City	
Non Causal Part Numbers			Dealer State/Province	
Fault Code			Dealer Country	USA
Diagnostic Trouble Code			Dealer Phone Number	
Labor Operation Code			Attachment	
Communication Type			VOQ Component Description Code	
Maintenance Date	29-Nov-2007			

Customer Comment OCCASIONALLY, WHILE MY CAR IS IDLE BOTH PARKED BUT RUNNING OR WHILE I'M IN TRAFFIC, THE ENGINE ACCELERATES AND THE RPM GAUGE RACES. THE ENGINE WILL NOT STOP RACING UNLESS I TURN THE CAR OFF. ALSO, DRIVER CAR DOOR DOES NOT OPEN FROM THE INSIDE, SERVICE DEALER SAYS I NEED TO REPLACE ENTIRE LOCK INCLUDING COMPONENTS NOT COVERED UNDER MAP

Technician Comment

CQIS Recommendations

Tire Information

Tire Manufacturer	Unknown	Tire Size	Unknown
Tire Brand Series		Wheel	
DOT Left Front		DOT Right Front	
DOT Left Rear		DOT Right Rear	
DOT Left Inner		DOT Right Inner	
DOT Spare			

Vehicle Information

VIN	*4F2CU	Engine Serial Number	UNKNOWN
Model Year	2001	Engine Description	Unknown
Transmission	Unknown	Vehicle Description	TRIBUTE
Body Cab Style	UNKN Unknown	Drive Line	Unknown
Production Date		Retail Sale Indicator Code	
Plant Description	Unknown	Reaquired Vehicle	
Build Region		Warranty Start Date	
Build Country Code		Transmission Serial Number	UNKNOWN
Mileage	0	Vehicle Axle Ratio	
Vehicle Restraint Code			

Disclaimer:

This data is for use as one of several potential "awareness" indicators for the Ford Motor Co. Enhanced Concern Identification System. It is unverified, draft, summary data generated from a computer "word search" of customer and technician symptom comments. Supplier data, technician and customer comments are unverified and actual root cause of any potential issue is not established by this summary.

[Contact ODRHELP](#)

Copyright 2001 Ford Motor Co All Rights Reserved

PE12-019

MADZA

9/6/2012

APPENDIX 3 SUBJECT
VEHICLES

Consumer Reports

VOQ Mazda

ECI

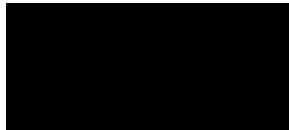



Concern Driven Reporting

Report Detail

Note: Field which are grayed (ghosted) are currently being mapped to the data warehouse. They are not presently being populated.

ECI Record		Source Code	VOQ Mazda
------------	--	-------------	-----------

Commodity Assignment

Commodity	powertrain-engine-accel pedal/linkage/controls	Symptom	engine power-stall
Commodity	powertrain-engine-accel pedal/linkage/controls	Symptom	function-shuts off
Commodity	powertrain-engine-accel pedal/linkage/controls	Symptom	pedal concerns-accelerator pedal
Significant Event		Verified	Y

Tread Information

Report Details

Source Claim Key		ODI 10121980	Warranty Component Classification (WCC)	
Corporate Product Systems Classification (CPSC)			Time in Service	
Customer Condition Code			V Function Group (VFG)	
Source System Program Type			Repair/Report/Paid Date	29-May-2002
Version Series Code	UNKN		Load Date	02-Jan-2008
Causal Part Prefix- Base - Suffix	-		Dealer Code	
Causal Part Name	NOT PROVIDED BY SOURCE		Dealer Name	NOT PROVIDED BY SOURCE
Non Causal Part Prefix-Base-Suffix			Dealer City	
Non Causal Part Numbers			Dealer State/Province	
Fault Code			Dealer Country	USA
Diagnostic Trouble Code			Dealer Phone Number	
Labor Operation Code			Attachment	
Communication Type			VOQ Component Description Code	
Maintenance Date	02-Jan-2008			

Customer Comment	DT VEHICLE SHUTS OFF COMPLETELY DURING MOVEMENT. IT ALSO SPEEDS UP WITHOUT THE ACCELERATOR PEDAL BEING DEPRESSED. ALSO, TRANSMISSION DOES NOT CHANGE GEARS. *A
Technician Comment	
C Q I S Recommendations	

Tire Information

Tire Manufacturer	Unknown	Tire Size	Unknown
Tire Brand Series		Wheel	
DOT Left Front		DOT Right Front	
DOT Left Rear		DOT Right Rear	
DOT Left Inner		DOT Right Inner	
DOT Spare			

Vehicle Information

VIN	*4F2YU	Engine Serial Number	UNKNOWN
Model Year	2002	Engine Description	Unknown
Transmission	Unknown	Vehicle Description	TRIBUTE
Body Cab Style	UNKN Unknown	Drive Line	Unknown
Production Date		Retail Sale Indicator Code	
Plant Description	Unknown	Reaquired Vehicle	
Build Region		Warranty Start Date	
Build Country Code		Transmission Serial Number	UNKNOWN
Mileage	20	Vehicle Axle Ratio	
Vehicle Restraint Code			

Disclaimer:

This data is for use as one of several potential "awareness" indicators for the Ford Motor Co. Enhanced Concern Identification System. It is unverified, draft, summary data generated from a computer "word search" of customer and technician symptom comments. Supplier data, technician and customer comments are unverified and actual root cause of any potential issue is not established by this summary.

[Contact ODR Help](#)

PE12-019

MADZA

9/6/2012

APPENDIX 3 SUBJECT
VEHICLES

Consumer Reports

VOQ Mazda

ECI

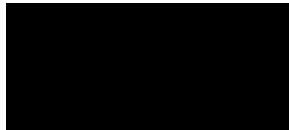

CQIS Recommendation	
---------------------	--

Tire Information			
Tire Manufacturer	Unknown	Tire Size	Unknown
Tire Brand Series		Wheel	
DOT Left Front		DOT Right Front	
DOT Left Rear		DOT Right Rear	
DOT Left Inner		DOT Right Inner	
DOT Spare			

Vehicle Information			
VIN	*	Engine Serial Number	UNKNOWN
Model Year	2002	Engine Description	Unknown
Transmission	Unknown	Vehicle Description	TRIBUTE
Body Cab Style	UNKN Unknown	Drive Line	Unknown
Production Date		Retail Sale Indicator Code	
Plant Description	Unknown	Reaquired Vehicle	
Build Region		Warranty Start Date	
Build Country Code		Transmission Serial Number	UNKNOWN
Mileage	0	Vehicle Axle Ratio	
Vehicle Restraint Code			

Disclaimer:

This data is for use as one of several potential "awareness" indicators for the Ford Motor Co. Enhanced Concern Identification System. It is unverified, draft, summary data generated from a computer "word search" of customer and technician symptom comments. Supplier data, technician and customer comments are unverified and actual root cause of any potential issue is not established by this summary.

[Contact ODR HELP](#)
 Copyright 2001 Ford Motor Co. All Rights Reserved

PE12-019

MADZA

9/6/2012

APPENDIX 3 SUBJECT
VEHICLES

Consumer Reports

VOQ Mazda

ECI

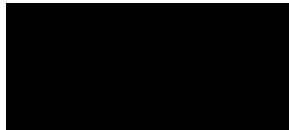



Concern Driven Reporting

Report Detail

Note: Field which are grayed (ghosted) are currently being mapped to the data warehouse. They are not presently being populated.

ECI Record		Source Code	VOQ Mazda
------------	--	-------------	-----------

Commodity Assignment			
Commodity	powertrain-engine-accel pedal/linkage/controls	Symptom	function-malfunction/inoperative
Commodity	powertrain-engine-accel pedal/linkage/controls	Symptom	mod-weather-cold
Commodity	powertrain-engine-accel pedal/linkage/controls	Symptom	pedal concerns-accelerator pedal
Commodity	powertrain-engine-accel pedal/linkage/controls	Symptom	sticks/binds/grabs
Significant Event		Verified	Y

Tread Information

Report Details

Source Claim Key		ODI 10439165	Warranty Component Classification (WCC)	
Corporate Product Systems Classification (CPSC)			Time in Service	
Customer Condition Code			V Function Group (VFG)	
Source System Program Type			Repair/Report/Paid Date	26-Nov-2009
Version Series Code	UNKN		Load Date	14-Dec-2011
Causal Part Prefix- Base - Suffix	- -		Dealer Code	
Causal Part Name	NOT PROVIDED BY SOURCE		Dealer Name	NOT PROVIDED BY SOURCE
Non Causal Part Prefix-Base-Suffix			Dealer City	
Non Causal Part Numbers			Dealer State/Province	
Fault Code			Dealer Country	USA
Diagonstic Trouble Code			Dealer Phone Number	
Labor Operation Code			Attachment	
Communication Type			VOQ Component Description Code	
Maintenance Date	14-Dec-2011			

Customer Comment	AFTER READING OTHER SIMILAR COMPLAINTS, I FELT COMPELLED TO ADDRESS THIS ISSUE WITH THE GAS PEDAL. IT SEEMS MAZDA HAS BEEN AWARE OF THIS PROBLEM FOR MANY YEARS, YET NO RECALL. THE GAS PEDAL STICKS IN WEATHER COLDER THAN 50 DEGREES. FOR AN ALL TERRAIN VEHICLE (SUV) WHICH IS MADE TO GO OFF ROAD AND IN MOUNTAINS, THIS IS A PRETTY SERIOUS SAFETY ISSUE. WHEN I CONFERRED WITH MY LOCAL MAZDA DEALER, THEY WANTED TO CHARGE ME \$400 FOR PARTS AND LABOR TO REPLACE A FAULTY MECHANISM. I FEEL I SHOULDN'T HAVE TO PAY FOR SOMETHING WHICH IS INHERENT WITH THESE TRIBUTE VEHICLES AND FOR WHICH MAZDA IS FULLY AWARE
------------------	---

Technician Comment	
--------------------	--

CQIS Recommendations	
----------------------	--

Tire Information

Tire Manufacturer	Unknown	Tire Size	Unknown
Tire Brand Series		Wheel	
DOT Left Front		DOT Right Front	
DOT Left Rear		DOT Right Rear	
DOT Left Inner		DOT Right Inner	
DOT Spare			

Vehicle Information

VIN	*4F2Y2	Engine Serial Number	UNKNOWN
Model Year	2005	Engine Description	Unknown
Transmission	Unknown	Vehicle Description	TRIBUTE
Body Cab Style	UNKN Unknown	Drive Line	Unknown
Production Date		Retail Sale Indicator Code	
Plant Description	Unknown	Reaquired Vehicle	
Build Region		Warranty Start Date	
Build Country Code		Transmission Serial Number	UNKNOWN
Mileage	0	Vehicle Axle Ratio	
Vehicle Restraint Code			

Disclaimer:

This data is for use as one of several potential "awareness" indicators for the Ford Motor Co. Enhanced Concern Identification System. It is unverified, draft, summary data generated from a computer "word search" of customer and technician symptom comments. Supplier data, technician and customer comments are unverified and actual root cause of any potential issue is not established by this summary.

[Contact ODRHELP](#)

Copyright 2001 Ford Motor Co All Rights Reserved

PE12-019

MADZA

9/6/2012

APPENDIX 3 SUBJECT
VEHICLES

Consumer Reports

VOQ Mazda

ECI

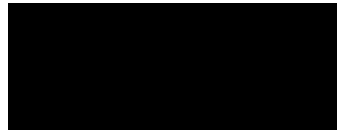



Concern Driven Reporting

Report Detail

Note: Field which are grayed (ghosted) are currently being mapped to the data warehouse. They are not presently being populated.

ECI Record		Source Code	VOQ Mazda
------------	--	-------------	-----------

Commodity Assignment			
Commodity	powertrain-engine-accel pedal/linkage/controls	Symptom	mod-driving condition-on acceleration
Commodity	powertrain-engine-accel pedal/linkage/controls	Symptom	mod-driving condition-while driving
Commodity	powertrain-engine-accel pedal/linkage/controls	Symptom	mod-no indication (sudden)
Commodity	powertrain-engine-accel pedal/linkage/controls	Symptom	unintended acceleration
Significant Event	Property Damage;	Verified	N

Tread Information

Report Details

Source Claim Key		ODI 10033988	Warranty Component Classification (WCC)	
Corporate Product Systems Classification (CPSC)			Time in Service	
Customer Condition Code			V Function Group (VFG)	
Source System Program Type			Repair/Report/Paid Date	14-Aug-2003
Version Series Code	UNKN		Load Date	29-Nov-2007
Causal Part Prefix- Base - Suffix	- -		Dealer Code	
Causal Part Name	NOT PROVIDED BY SOURCE		Dealer Name	NOT PROVIDED BY SOURCE
Non Causal Part Prefix-Base-Suffix			Dealer City	
Non Causal Part Numbers			Dealer State/Province	
Fault Code			Dealer Country	USA
Diagonstic Trouble Code			Dealer Phone Number	
Labor Operation Code			Attachment	
Communication Type			VOQ Component Description Code	
Maintenance Date	29-Nov-2007			

Customer Comment	VEHICLE EXPERIENCED SUDDEN ACCELERATION WHILE DRIVING AT THE PARKING LOT, AND VEHICLE COLLIDED WITH A BRICK WALL, SMASHING THE FRONT. DEALER NOTIFIED. *A		
Technician Comment			
C Q I S Recommendations			

Tire Information

Tire Manufacturer	Unknown	Tire Size	Unknown
Tire Brand Series		Wheel	
DOT Left Front		DOT Right Front	
DOT Left Rear		DOT Right Rear	
DOT Left Inner		DOT Right Inner	
DOT Spare			

Vehicle Information

VIN	*	Engine Serial Number	UNKNOWN
Model Year	2002	Engine Description	Unknown
Transmission	Unknown	Vehicle Description	TRIBUTE
Body Cab Style	UNKN Unknown	Drive Line	Unknown
Production Date		Retail Sale Indicator Code	
Plant Description	Unknown	Reaquired Vehicle	
Build Region		Warranty Start Date	
Build Country Code		Transmission Serial Number	UNKNOWN
Mileage	0	Vehicle Axle Ratio	
Vehicle Restraint Code			

Disclaimer:

This data is for use as one of several potential "awareness" indicators for the Ford Motor Co. Enhanced Concern Identification System. It is unverified, draft, summary data generated from a computer "word search" of customer and technician symptom comments. Supplier data, technician and customer comments are unverified and actual root cause of any potential issue is not established by this summary.

PE12-019

MADZA

9/6/2012

APPENDIX 3 SUBJECT
VEHICLES

DAMAGE CLAIM



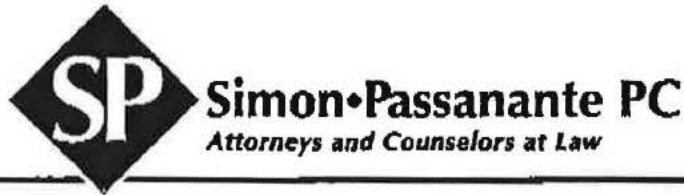

May 23, 2005

Via Facsimile – Hard Copy to Follow

Julie Shull
Shook, Hardy & Bacon, L.L.P.
One Kansas City Place
1200 Main Street
Kansas City, MO 64105-2118

re: *January 26, 2005 Rollover in Stoddard Co.*

Dear Julie:

As we discussed today, enclosed please find the police report relating to a rollover of a 2004 Mazda Tribute where [REDACTED] my client, was injured. C.H. Parsons of Parsons & Wilson in Dexter, Missouri represents Whitney Malloy and her family.

Our office is investigating this rollover on behalf of [REDACTED] and her family. To that end we have contacted William Rosenbluth, of Automotive Systems Analysis in Reston, Virginia, to download the information from the black box in the 2004 Mazda Tribute involved in this incident. This inspection and downloading will take place on June 9, 2005 at 10:00 a.m. in Dexter, Missouri with the Malloy family's permission.

Mr. Rosenbluth has requested that we notify Ford Motor Company and Mazda Motor of America, Inc. of this inspection and provide to Ford and Mazda the opportunity to participate. Accordingly, if you could contact Ford, and Mazda if possible, and inform the companies of this inspection, it would be appreciated. I am directing this correspondence to you as your office has represented Ford Motor Company in the past on cases I have filed in Missouri. I have also contacted Lisa A. Keesling of Bryan Cave here in St. Louis, who has in the past represented Mazda, and am awaiting her return call.

Please let me know if either Ford or Mazda would like to participate in the inspection and downloading of the black box on June 9, 2005 and if so, I can provide more details about the location, etc.

Page -2 -
May 23, 2005

Thank you for your assistance with this matter. Please contact me if you have any further questions or if more information is needed.

Very truly yours,

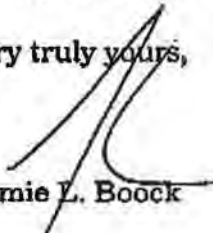

Jamie L. Boock

Enclosure

cc: PJP
C.H. Parsons
William Rosenbluth



MISSOURI UNIFORM ACCIDENT REPORT

SPACE USED FOR BARCODE		1 - AGENCY NAME AND OFF MISSOURI STATE HIGHWAY PATROL MOMHPEE00			
------------------------	--	---	--	--	--

LEFT THE SCENE <input type="checkbox"/> YES <input checked="" type="checkbox"/> NO	CLEARED <input type="checkbox"/> YES <input type="checkbox"/> NO	ACCIDENT CLASSIFICATION	PROPERTY DAMAGE ONLY <input type="checkbox"/>	NUMBER INJURED 2	NUMBER KILLED 0	REPORT / CASE / INCIDENT NUMBER
NUMBER OF VEHICLES INVOLVED 1	ACCIDENT DATE 01/26/2005	ACCIDENT TIME (ML) 0715	TIME NOTIFIED (ML) 0719	TIME ARRIVED (ML) 0726	INVESTIGATION DATE 01/26/2005	

2 - LOCATION

COUNTY Stoddard	104	MUNICIPALITY NA	9999	BEAT / ZONE 11	TRAV DIST / PCT E	INVESTIGATED AT SCENE <input checked="" type="checkbox"/> YES <input type="checkbox"/> NO
ON US 60	DISTANCE FROM FEET	LOCATION <input type="checkbox"/> AFTER <input type="checkbox"/> BEFORE <input checked="" type="checkbox"/> AT	INTERSECTING STREET OR ROADWAY CRD 531 (S)	SPEED LIMIT 45	GEO. CODE NA	GPS LONGITUDE W 089° 53' 51.3"
ROADWAY DIRECTION W	SPEED LIMIT 65	MILES				LATITUDE N 036° 49' 51.3"

ROAD MAINTAINED BY 1. STATE 2. COUNTY 3. MUNICIPAL 4. PRIVATE PROPERTY 5. OTHER

3 - DAMAGE TO PROPERTY OTHER THAN VEHICLES NONE

GIVE OWNER'S NAME AND ADDRESS, DESCRIPTION OF PROPERTY, AND DAMAGE.
 Modot One way sign and post; post broken signs bent

4. DRIVER 1

DRIVER'S FULL NAME (LAST, FIRST, MI) **Benton, MO,** ADDRESS (STREET, CITY, STATE, ZIP)

DRIVER LICENSE NUMBER / ID NUMBER STATE **MO** TYPE OF LICENSE 1. OPERATOR CLASS 2. CDL CLASS 3. PERMIT 4. UNLICENSED 5. MC ONLY 6. UNKOWN 7. NA MC ENDORSEMENT YES NO NA

PROOF OF INSURANCE YES NO NOT REQUIRED INSURANCE COMPANY **None** DRIVER VEHICLE NA POLICY NUMBER

VEHICLE 1

YEAR **2004** MAKE **Mazda** MODEL **Tribute** COLOR **White**

LIC. PLATE NO. STATE **MO** YEAR **2005** VIN **4P2CZ04134K** TOTAL NO. OF OCCUPANTS **2**

VEHICLE OWNER NAME (LAST, FIRST, MI) / COMMERCIAL CARRIER **Springfield, MO,** ADDRESS (STREET, CITY, STATE, ZIP) SAME AS DRIVER

VEHICLE DAMAGE (Circle all damaged areas) NONE INITIAL IMPACT NO. NA **14**

REAR 13 - Undercarriage 14 - Windshield 20 - Bumpud 21 - Towed Unit 22 - Cargo

TOWED FROM SCENE YES NO TOW CO. INFORMATION **D & L (Rotation), Box 162, Essex, MO, 63846, (573) 283-5561**

5. DRIVER 2

DRIVER'S FULL NAME (LAST, FIRST, MI) ADDRESS (STREET, CITY, STATE, ZIP)

DRIVERS LICENSE NUMBER / ID NUMBER STATE TYPE OF LICENSE 1. OPERATOR CLASS 2. CDL CLASS 3. PERMIT 4. UNLICENSED 5. MC ONLY 6. UNKOWN 7. NA MC ENDORSEMENT YES NO NA

PROOF OF INSURANCE YES NO NOT REQUIRED INSURANCE COMPANY DRIVER VEHICLE NA POLICY NUMBER

YEAR MAKE MODEL COLOR

LIC. PLATE NO. STATE YEAR VIN TOTAL NO. OF OCCUPANTS

VEHICLE OWNER NAME (LAST, FIRST, MI) / COMMERCIAL CARRIER ADDRESS (STREET, CITY, STATE, ZIP) SAME AS DRIVER

VEHICLE DAMAGE (Circle all damaged areas) NONE INITIAL IMPACT NO. NA

REAR 18 - Undercarriage 19 - Windshield 20 - Bumpud 21 - Towed Unit 22 - Cargo

TOWED FROM SCENE YES NO TOW CO. INFORMATION

6 - WITNESS NONE IDENTIFIED

NAME OF WITNESS	ADDRESS (STREET, CITY, STATE, ZIP)	TELEPHONE NO.
Birch Tree, MO,		
Mountainview, MO,		
Emminence, MO,		

COLLISION DIAGRAM	Direction of Impact (circle one)	V1	NES	V2	NES	V3	NES	V4	NES	Est. Speed - Fable Only				INDICATE NORTH
										V1 NA	V2 NA	V3 NA	V4 NA	

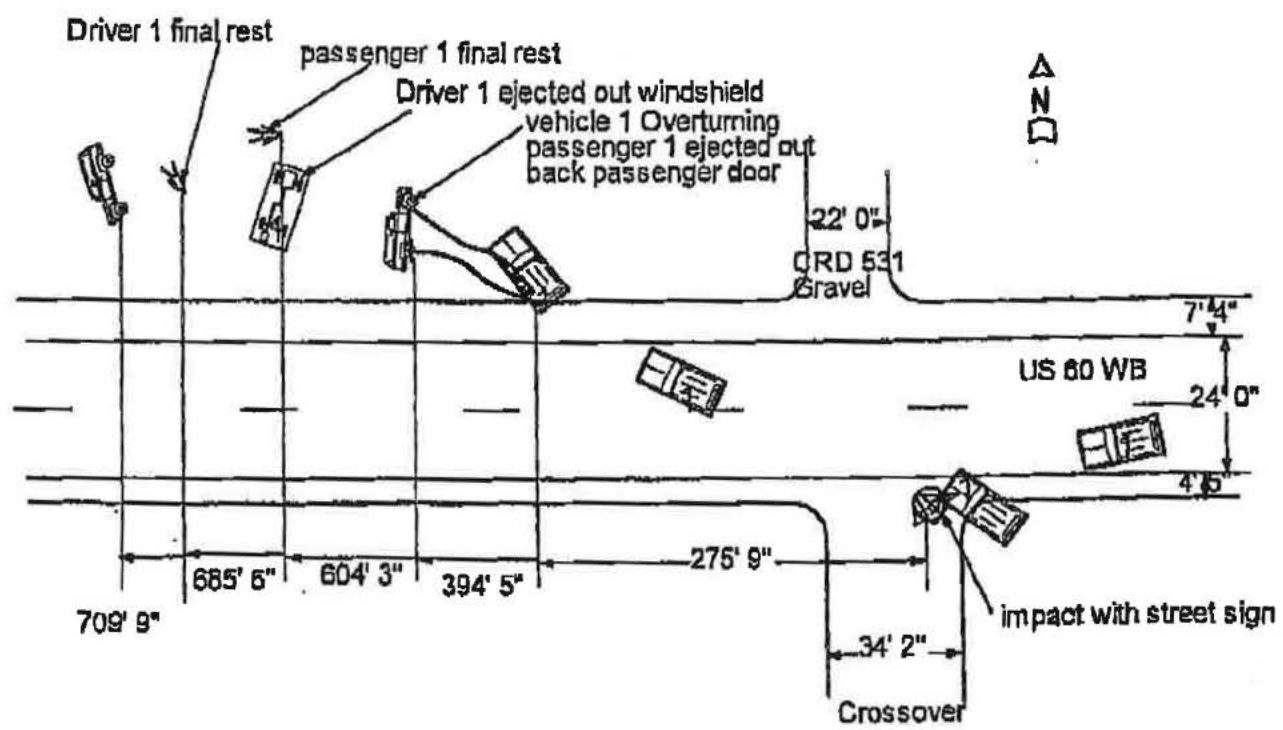

INDICATE VEHICLE NAMES REQUIRED UNLESS DELAYER REPORT DIAGRAM NOT TO SCALE

B. EVIDENTIARY PHOTOS TAKEN
 YES NO BY WHOM NA AVAILABLE FROM NA

RECONSTRUCTION - Includes Narrative, Diagram, & Photo(s)
 YES NO BY WHOM NA

11. APPROPRIATE CONTRIBUTING CIRCUMSTANCES V1 V2 <input type="checkbox"/> <input type="checkbox"/> 1. Vehicle Defect (explain) <input type="checkbox"/> <input type="checkbox"/> 2. Traffic Control Inoperative or Missing <input type="checkbox"/> <input type="checkbox"/> 3. Improperly Stopped on Right-of-Way <input checked="" type="checkbox"/> <input type="checkbox"/> 4. Speed - Exceeded Limit <input type="checkbox"/> <input type="checkbox"/> 5. Too Fast for Conditions <input type="checkbox"/> <input type="checkbox"/> 6. Improper Passing <input type="checkbox"/> <input type="checkbox"/> 7. Violation Signal / Sign <input type="checkbox"/> <input type="checkbox"/> 8. Wrong Side (not passing) <input type="checkbox"/> <input type="checkbox"/> 9. Following Too Close <input type="checkbox"/> <input type="checkbox"/> 10. Improper Signal <input type="checkbox"/> <input type="checkbox"/> 11. Improper Backing <input type="checkbox"/> <input type="checkbox"/> 12. Improper Turn <input type="checkbox"/> <input type="checkbox"/> 13. Improper Lane Usage / Change <input type="checkbox"/> <input type="checkbox"/> 14. Wrong Way (One-Way) <input type="checkbox"/> <input type="checkbox"/> 15. Improper Sign From Park <input type="checkbox"/> <input type="checkbox"/> 16. Improperly Parked <input type="checkbox"/> <input type="checkbox"/> 17. Failed to Yield <input type="checkbox"/> <input type="checkbox"/> 18. Alcohol <input type="checkbox"/> <input checked="" type="checkbox"/> 19. Drugs <input type="checkbox"/> <input type="checkbox"/> 20. Physical Impairment (explain) <input type="checkbox"/> <input type="checkbox"/> 21. Inattention (explain) P1 P2 V1 V2 <input type="checkbox"/> <input type="checkbox"/> <input type="checkbox"/> <input type="checkbox"/> 22. None	19. PEDESTRIAN INVOLVEMENT P1 P2 <input checked="" type="checkbox"/> NA <input type="checkbox"/> <input type="checkbox"/> 1. At Intersection <input type="checkbox"/> <input type="checkbox"/> 2. Not At Intersection CROSSING ROAD <input type="checkbox"/> <input type="checkbox"/> 3. With Signal <input type="checkbox"/> <input type="checkbox"/> 4. Against Signal <input type="checkbox"/> <input type="checkbox"/> 5. No Signal <input type="checkbox"/> <input type="checkbox"/> 6. Diagonally <input type="checkbox"/> <input type="checkbox"/> 7. Within Crosswalk <input type="checkbox"/> <input type="checkbox"/> 8. Within Marked Crosswalk <input type="checkbox"/> <input type="checkbox"/> 9. Behind / In Front of Parked Car <input type="checkbox"/> <input type="checkbox"/> 10. With Traffic <input type="checkbox"/> <input type="checkbox"/> 11. Against Traffic <input type="checkbox"/> <input type="checkbox"/> 12. Getting On / Off Vehicle <input type="checkbox"/> <input type="checkbox"/> 13. Standing / Lying / Sitting on Road <input type="checkbox"/> <input type="checkbox"/> 14. Pushing / Working on Vehicle <input type="checkbox"/> <input type="checkbox"/> 15. Other Working <input type="checkbox"/> <input type="checkbox"/> 16. Playing on Road <input type="checkbox"/> <input type="checkbox"/> 17. Off Roadway 25. ROAD SURFACE <input checked="" type="checkbox"/> 1. Concrete <input type="checkbox"/> 3. Brick <input type="checkbox"/> 5. Dirt / Sand <input type="checkbox"/> 2. Asphalt <input type="checkbox"/> 4. Gravel <input type="checkbox"/> 6. Multi-Surface	20. VISION OBSCURED V1 V2 <input type="checkbox"/> <input type="checkbox"/> 1. Windshield <input type="checkbox"/> <input type="checkbox"/> 2. Load on Vehicle <input type="checkbox"/> <input type="checkbox"/> 3. Trees / Brush <input type="checkbox"/> <input type="checkbox"/> 4. Building <input type="checkbox"/> <input type="checkbox"/> 5. Embankment <input type="checkbox"/> <input type="checkbox"/> 6. Signs/Barriers <input type="checkbox"/> <input type="checkbox"/> 7. Hitchhiker <input type="checkbox"/> <input type="checkbox"/> 8. Parked Cars <input type="checkbox"/> <input type="checkbox"/> 9. Moving Cars <input type="checkbox"/> <input type="checkbox"/> 10. Glare <input type="checkbox"/> <input type="checkbox"/> 11. Other (explain) <input checked="" type="checkbox"/> <input type="checkbox"/> 12. Not Obscured 23. LIGHT CONDITION <input checked="" type="checkbox"/> 1. Daylight <input type="checkbox"/> 2. Dark with Street Lights On <input type="checkbox"/> 3. Dark with Street Lights Off <input type="checkbox"/> 4. Dark - No Street Lights <input type="checkbox"/> 5. Indeterminate (explain)	22. TRAFFIC CONTROL V1 V2 <input type="checkbox"/> <input type="checkbox"/> 1. Construction Zone <input type="checkbox"/> <input type="checkbox"/> 2. Outer Work Zone <input type="checkbox"/> <input type="checkbox"/> 3. School Zone <input type="checkbox"/> <input type="checkbox"/> 4. Stop Sign <input type="checkbox"/> <input type="checkbox"/> 5. Electric Signal <input type="checkbox"/> <input type="checkbox"/> 6. RR Signal / Gate <input type="checkbox"/> <input type="checkbox"/> 7. Yield Sign <input type="checkbox"/> <input type="checkbox"/> 8. Officer / Flagman <input type="checkbox"/> <input type="checkbox"/> 9. No Passing Zone <input type="checkbox"/> <input type="checkbox"/> 10. Turn Restricted <input type="checkbox"/> <input type="checkbox"/> 11. Signal on School Bus <input checked="" type="checkbox"/> <input type="checkbox"/> 12. None	22. ROAD CHARACTER ALIGNMENT <input checked="" type="checkbox"/> 1. Straight <input type="checkbox"/> 2. Curve PROFILE <input checked="" type="checkbox"/> 1. Level <input type="checkbox"/> 2. Grade <input type="checkbox"/> 3. Hillside
---	--	---	---	--

27 - COMMERCIAL MOTOR VEHICLE (Complete for each commercial vehicle involved.)

A. CMV CRITERIA Answer the following to determine if this section should be completed. 1. Does this accident involve any of the following: 1.a person fatally injured; or 2.a person transported for medical attention; or 3.a vehicle towed from the scene of the accident? <input type="checkbox"/> NO - DO NOT COMPLETE <input checked="" type="checkbox"/> YES - GO TO NUMBER 2 2. Examine each vehicle to determine if it is a commercial vehicle based on the following: 1.a truck with GVWR of more than 10,000 lbs. and engaged in commerce; or 2.a bus or school bus (8 or more including driver); or 3.a vehicle with a hazardous materials placard <input type="checkbox"/> NO - DO NOT COMPLETE <input checked="" type="checkbox"/> YES - COMPLETE SECTIONS B - E	B. CARRIER ID NUMBER V1 ICC NO. MC _____ USDOT NO. _____ V2 ICC NO. MC _____ USDOT NO. _____	E. CARGO BODY TYPE V1 V2 <input type="checkbox"/> <input type="checkbox"/> 1. Enclosed Box <input type="checkbox"/> <input type="checkbox"/> 2. Cargo Tank <input type="checkbox"/> <input type="checkbox"/> 3. Flatbed <input type="checkbox"/> <input type="checkbox"/> 4. Dump <input type="checkbox"/> <input type="checkbox"/> 5. Concrete Mixer <input type="checkbox"/> <input type="checkbox"/> 6. Auto Transporter <input type="checkbox"/> <input type="checkbox"/> 7. Garbage / Refuse <input type="checkbox"/> <input type="checkbox"/> 8. Grain, Chaff, Gravel <input type="checkbox"/> <input type="checkbox"/> 9. Pole Trailer <input type="checkbox"/> <input type="checkbox"/> 10. Other
C. HAZARDOUS MATERIAL PLACARD NUMBER <input type="checkbox"/> NA V1 4-Digit Placard Number from Diamond / Box _____ Number from Bottom of Diamond _____ V2 4-Digit Placard Number from Diamond / Box _____ Number from Bottom of Diamond _____	D. TRAFFICWAY <input type="checkbox"/> 1. Two-Way; Not Divided <input type="checkbox"/> 2. Two-Way; Divided; Unprotected Median <input type="checkbox"/> 3. Two-Way; Divided; Protective Median Barrier <input type="checkbox"/> 4. One-Way; Not Divided	

28 - NARRATIVE / STATEMENTS (if additional room is necessary, attach a separate sheet.)

This accident occurred as vehicle 1 was westbound on US 60. Vehicle 1 traveled off the south side of the road and struck a road sign. Vehicle 1 traveled across westbound US 60 off the north side of the road and overturned several times ejecting the passenger out the passenger side rear door on the first roll and ejecting the driver out the windshield several rolls later.

Driver 1 was unable to provide a statement at the accident scene. Arch Air Medical Helicopter flew driver 1 to St. Francis Hospital. Air Evac Medical Helicopter flew passenger 1 to St. Francis Hospital. Both Passenger 1 and Driver 1 were flown from St. Francis Hospital to St. Louis University Hospital by Arch Air Medical Helicopter. Stoddard County Ambulance Personnel and Dexter First Responders treated driver 1 and Passenger 1 at the scene.

All four witnesses indicated that vehicle 1 was traveling at or near 100 miles per hour, passing vehicles, lost control struck a road sign, crossed the road and overturned in the ditch ejecting passenger 1 on the first roll.

██████████ Dexter Mo. ██████████ witnessed vehicle 1 travel off the road a few miles before the accident and take off traveling at a very high rate of speed, but did not witness the actual accident.

██████████, Van Buren, Mo. ██████████ witnessed vehicle 1 travel off the road and overturn, but did not witness the striking of the road sign

29. REPORTING OFFICER SIGNATURE Michael D Lynch <i>[Signature]</i>	DSN / BADGE NO. 1161	BEAT / ZONE 11	TOWN / DIST (PST) E
REVIEWING OFFICER 1 SIGNATURE <i>[Signature]</i>	DSN / BADGE NO. 95	REVIEWING OFFICER 2 SIGNATURE	DSN / BADGE NO.

PE12-019

MADZA

9/6/2012

APPENDIX 3 SUBJECT

VEHICLES

DAMAGE CLAIM

42006002

State Farm Insurance Companies



June 12, 2006

State Farm Insurance
Subrogation Services
PO Box 2371
Bloomington, IL 61702-2371

Certified Mail-Return Receipt Requested

Mazda Motors of America/David Orr
7755 Irving Center Drive
Irving, CA 92718

RECEIVED
JUN 19 2006
LEGAL

RE: Claim Number: [REDACTED]
Date of Loss: February 4, 2005
Our Insured: [REDACTED]
Loss Location: Valley Stream, NY
Vehicle: Mazda, Tribute
VIN: 4F2CZ96183K [REDACTED]
Mileage: 1563
Your File Number:

Dear Sir/Madam:

This notice is to advise of a loss that occurred to our insured's vehicle. The damage was caused by recall #2704L. The accelerator cable prevented the throttle from returning to the idle position. Our driver was backing when the defect occurred and hit another vehicle. Our documents concern the other vehicle

Our investigation indicates that Mazda Motors of America/David Orr is responsible for this loss. By virtue of our payment, we are entitled to recover from the responsible party. Please consider this letter as our demand to Mazda Motors of America/David Orr for reimbursement of \$2,345.01.

Any settlement with State Farm's policyholder with respect to this loss must not prejudice our rights, as subrogator, and shall not be released by execution of a general release with such policyholder.

In order to assist you in evaluating and processing the claim we are asserting, we may provide nonpublic personal information about our customer. We are sharing this information to effect, administer, or enforce a transaction authorized by the consumer. However, you are neither authorized nor permitted to: (1) use the customer information we provide for any purpose other than to

Page 2
June 12, 2006

evaluate and process the subrogation claim, or (2) disclose or share the customer information we provide for any purpose other than to evaluate and process the subrogation claim.

Sincerely,



Doug Flesher
Claim Representative
(877) 457-8276, Team 60

State Farm Mutual Automobile Insurance Company

Enclosure *cdg*



RBZ0006Z
date: 06-13-06

page: 1

route to: Steve Lollar

STATE FARM MUTUAL AUTOMOBILE INSURANCE COMPANY

AUTO PAYMENTS BY COL

claim number

policy number

named insured

date of loss

02-04-05

COL 200

C denotes consolidated payment
P denotes previous data

E denotes EFT payment

COL: 200 indemnity: 2,345.01 dir rcov: 0.00 expense: 0.00

payment number	payee	amount	status	COL	pay cd	rsn	reporting party
E	ENTERPRISE RENT	337.71	PAID	205	3		COHEN, L
E	MERRICK ROAD CO	2,007.30	PAID	200	1		COHEN, L



date: 06-13-06
time: 08:35 AM

route to: Lollar, Steve

STATE FARM MUTUAL AUTOMOBILE INSURANCE COMPANY

VEHICLE DAMAGE REPORT

claim number

date of loss
02-04-05

```

*****
* Estimate Vehicle Info *
*
* Vehicle Owner: *
* Vehicle Description: 05 HOND PILOT 4X4 EX 4D UTV B-533M-4 *
*
*****

```

03/03/2005 AT 01:05 PM

JOB NUMBER: [REDACTED]

MERRICK ROAD COLLISION CORP.
LICENSE # [REDACTED] FEDERAL ID # [REDACTED]
QUALITY IS NOT RUSHED
214 MERRICK ROAD
LYNBROOK , U.S.A., NY 11563
(516)593-3636 FAX: (516)599-4544

SUPPLEMENT OF RECORD 1 WITH SUMMARY

WRITTEN BY: WILLIAM ROTH #IA-934502-FQ01 03/03/2005 01:05 PM
ADJUSTER: TEAM 4 PROC (631)385-6775

INSURED: STATE FARM INSURED
OWNER: [REDACTED]
ADDRESS: [REDACTED]
OCEANSIDE, NY [REDACTED]
EVENING: ([REDACTED])

CLAIM # [REDACTED]
POLICY # [REDACTED]
DEDUCTIBLE:
DATE OF LOSS: 02/04/2005 AT 08:45 PM
TYPE OF LOSS: LIABILITY
POINT OF IMPACT: 10. LEFT FRONT PIL

INSPECT MERRICK ROAD COLLISION CORP.
LOCATION: 214 MERRICK ROAD
LYNBROOK , U.S.A., NY 11563

BUSINESS: (516)593-3636

INSURANCE STATE FARM INSURANCE COMPANIES
COMPANY: 1305 OLD WALT WHITMAN ROAD
MELVILLE, NY 11747

BUSINESS: (631)385-6775
7 DAYS TO REPAIR

2005 HOND PILOT 4X4 EX 6-3.5L-FI 4D UTV B-533M-4 INT:GREY
VIN: 2HKYF18475H [REDACTED] LIC: DDF7264 NY PROD DATE: 10/2004 ODOMETER: 1563
AIR CONDITIONING REAR DEFOGGER TILT WHEEL
CRUISE CONTROL INTERMITTENT WIPERS KEYLESS ENTRY
DUAL AIR CONDITION REAR WIPER STEERING WHEEL CONTROLS
BODY SIDE MOLDINGS DUAL MIRRORS PRIVACY GLASS
LUGGAGE/ROOF RACK CLEAR COAT PAINT METALLIC PAINT
POWER STEERING POWER BRAKES POWER WINDOWS
POWER LOCKS POWER DRIVER SEAT POWER MIRRORS
AM RADIO FM RADIO STEREO
CASSETTE SEARCH/SEEK CD CHANGER/STACKER
ANTI-LOCK BRAKES (4) DRIVER AIR BAG PASSENGER AIR BAG
FRONT SIDE IMPACT AIR BAG 4 WHEEL DISC BRAKES TRACTION CONTROL
CLOTH SEATS BUCKET SEATS POWER TRUNK/TAILGATE
AUTOMATIC TRANSMISSION 4 WHEEL DRIVE OVERDRIVE
ALUMINUM/ALLOY WHEELS

NO.	OP.	DESCRIPTION	QTY	EXT.	PRICE	LABOR	PAINT
1		FRONT BUMPER					
2	R&I	R&I BUMPER COVER				1.0	
3		FRONT LAMPS					
4	R&I	LT HEADLAMP ASSY				0.3	
5	REPL	AIM HEADLAMPS	1			0.4	
6		FENDER					
7	BLND	LT FENDER					1.0

03/03/2005 AT 01:05 PM

JOB NUMBER: [REDACTED]

SUPPLEMENT OF RECORD 1 WITH SUMMARY
2005 HOND PILOT 4X4 EX 6-3.5L-FI 4D UTV B-533M-4 INT:GREY

NO.	OP.	DESCRIPTION	QTY	EXT. PRICE	LABOR	PAINT
8	R&I	LT MUD GUARD			0.2	
9	R&I	LT SIDE MOLDING BLUE			0.2	
10#		CLEAN AND REFACE MOLDING	1	2.00	0.3	
11	R&I	LT FENDER LINER			0.4	
12		PILLARS, ROCKER & FLOOR				
13	R&I	LT ROCKER MOLDING			0.4	
14		FRONT DOOR				
15	REPL	LT OUTER PANEL	1	257.77	6.2	2.0
16		ADD FOR CLEAR COAT				0.8
17		ADD FOR MIRROR			0.3	
18		ADD FOR EDGING				0.5
19		ADD FOR CLEAR COAT				0.1
20		ADD FOR INSIDE				0.5
21		ADD FOR CLEAR COAT				0.1
22	REPL	LT WATER DEFLECTOR	1	28.87	INCL.	
23	R&I	LT LOCK ASSY EX			0.4	
24	REPL	LT TAPE	1	8.15	0.2	
25	REPL	LT BELT W' STRIP RETAINER CLIP TYPE 1	2	2.02		
26	REPL	RT BELT W' STRIP RETAINER CLIP TYPE 2	3	4.62		
27	R&I	LT DOOR GLASS HONDA EX			0.7	
28	R&I	LT DOOR CHECK			0.3	
29*	R&I	LT WINDOW REGULATOR			0.4*	
30#	R&I	PULL OUT WIRE HARNESS			0.3	
31*	RPR	LT BODY SIDE MLDG EX BLUE PEARL			0.5*	1.0
32		ADD FOR CLEAR COAT				0.2
33#		CLEAN AND REFACE DOOR MOLDING	1	5.00	0.3	
34		REAR DOOR				
35	BLND	LT DOOR SHELL				1.0
36	REPL	LT WATER DEFLECTOR	1	28.95	0.1	
37	R&I	LT BODY SIDE MLDG EX STEEL BLUE			0.4	
38	BLND	LT BODY SIDE MLDG EX STEEL BLUE				0.5
39#		CLEAN AND REFACE DOOR MOLDING	1	3.50	0.3	
40	R&I	LT MOVEABLE GLASS HONDA GREEN			0.7	
41*	R&I	LT FIXED GLASS HONDA GREEN			0.5*	
42	R&I	LT HANDLE, OUTSIDE			0.3	
43	R&I	LT R&I TRIM PANEL			0.4	
44#						
45#		***ADDITIONAL OPERATIONS***	1			
46#		PLASTIC CAR COVER	1	5.00	0.2	
47#		FLEX ADDITIVE	1	15.00		
48#		CORROSION PROTECTION	1	12.00	0.2	
49#		HAZ MAT REMOVAL	1	2.00		
50#		COLOR TINT TEST CARD	1		0.5	

03/03/2005 AT 01:05 PM

JOB NUMBER: [REDACTED]

SUPPLEMENT OF RECORD 1 WITH SUMMARY
2005 HOND PILOT 4X4 EX 6-3.5L-FI 4D UTV B-533M-4 INT:GREY

NO.	OP.	DESCRIPTION	QTY	EXT.	PRICE	LABOR	PAINT
		WET SAND AND POLISH	1			1.0	
N	52# S01	SEAM SEALER	1		15.00	0.5	
	53#	FLUTTER (PILLAR FOAM)	1		15.00		
	54#						
N	55#	PAINT MATERIALS	1		160.91		
	56# S01	FINAL BILL INDICATOR	1				
	57	OTHER CHARGES					
	58#	VEHICLE CONDITION = EXCELLENT	1		0.00		
SUBTOTALS ==>					565.79	17.9	7.7

LINE 52 : LABOR TO MASK OFF FOR CAULK/SEAM SEAL
 LINE 55 : NEW FORMULA AND IS NOT IN MITCHEL GUIDE, USED SIMILAR COLOR FOR COST PRICING

PARTS			565.79
BODY LABOR	17.9 HRS	@ \$ 50.00/HR	895.00
PAINT LABOR	7.7 HRS	@ \$ 50.00/HR	385.00
SUBTOTAL			\$ 1845.79
SALES TAX	\$ 1845.79	@ 8.7500%	161.51
GRAND TOTAL			\$ 2007.30
ADJUSTMENTS:			
DEDUCTIBLE			0.00
CUSTOMER PAY			\$ 0.00
INSURANCE PAY			\$ 2007.30

THIS ESTIMATE IS BASED ON OUR INSPECTION AND DOES NOT COVER ADDITIONAL PARTS OR LABOR WHICH IS REQUIRED AFTER WORK HAS BEEN STARTED. AFTER WORK HAS BEEN STARTED, WORN OR DAMAGED PARTS WHICH WERE NOT EVIDENT ON FIRST INSPECTION MAY BE DISCOVERED. OUR MOTTO - QUALITY IS NOT RUSHED-WE DON'T SELL BODY WORK, WE SELL CONFIDENCE .

*** PART PRICES ARE SUBJECT TO DEALER INVOICES. PART PRICES MAY VARY FROM ORIGINAL ESTIMATE DUE TO ESTIMATING DATA BASE ERRORS***

03/03/2005 AT 01:05 PM

JOB NUMBER: [REDACTED]

SUPPLEMENT OF RECORD 1 WITH SUMMARY
2005 HOND PILOT 4X4 EX 6-3.5L-FI 4D UTV B-533M-4 INT:GREY

ANY PERSON WHO KNOWINGLY AND WITH INTENT TO DEFRAUD ANY INSURANCE COMPANY OR OTHER PERSON FILES AN APPLICATION FOR COMMERCIAL INSURANCE OR A STATEMENT OF CLAIM FOR ANY COMMERCIAL OR PERSONAL INSURANCE BENEFITS CONTAINING ANY MATERIALLY FALSE INFORMATION, OR CONCEALS FOR THE PURPOSE OF MISLEADING, INFORMATION CONCERNING ANY FACT MATERIAL THERETO, AND ANY PERSON WHO, IN CONNECTION WITH SUCH APPLICATION OR CLAIM, KNOWINGLY MAKES OR KNOWINGLY ASSISTS, ABETS, SOLICITS OR CONSPIRES WITH ANOTHER TO MAKE A FALSE REPORT OF THE THEFT, DESTRUCTION, DAMAGE OR CONVERSION OF ANY MOTOR VEHICLE TO A LAW ENFORCEMENT AGENCY, THE DEPARTMENT OF MOTOR VEHICLES OR AN INSURANCE COMPANY, COMMITS A FRAUDULENT INSURANCE ACT, WHICH IS A CRIME, AND SHALL ALSO BE SUBJECT TO A CIVIL PENALTY NOT TO EXCEED FIVE THOUSAND DOLLARS AND THE VALUE OF THE SUBJECT MOTOR VEHICLE OR STATED CLAIM FOR EACH VIOLATION.

ESTIMATE BASED ON MOTOR CRASH ESTIMATING GUIDE. UNLESS OTHERWISE NOTED ALL ITEMS ARE DERIVED FROM THE GUIDE ARG4455 DATABASE DATE 02/2005, CCC DATA DATE 02/2005, AND THE PARTS SELECTED ARE OEM-PARTS MANUFACTURED BY THE VEHICLES ORIGINAL EQUIPMENT MANUFACTURER. OEM PARTS ARE AVAILABLE AT OE/VEHICLE DEALERSHIPS. ASTERISK (*) OR DOUBLE ASTERISK (**) INDICATES THAT THE PARTS AND/OR LABOR INFORMATION PROVIDED BY MOTOR MAY HAVE BEEN MODIFIED OR MAY HAVE COME FROM AN ALTERNATE DATA SOURCE. TILDE SIGN (~) ITEMS INDICATE MOTOR NOT-INCLUDED LABOR OPERATIONS. NON-ORIGINAL EQUIPMENT MANUFACTURER AFTERMARKET PARTS ARE DESCRIBED AS AM, QUAL REPL PARTS OR COMP REPL PARTS WHICH STANDS FOR COMPETITIVE REPLACEMENT PARTS. USED PARTS ARE DESCRIBED AS LKQ, QUAL RECY PARTS, RCY, OR USED. RECONDITIONED PARTS ARE DESCRIBED AS RECON. RECORDED PARTS ARE DESCRIBED AS RECORE. NAGS PART NUMBERS AND PRICES ARE PROVIDED BY NATIONAL AUTO GLASS SPECIFICATIONS, INC. POUND SIGN (#) ITEMS INDICATE MANUAL ENTRIES. SOME PARTS THAT ARE DESCRIBED AS RECON. MAY BE OE SURPLUS PARTS OR OTHER OE PARTS OFFERED AT A SPECIAL PRICING DISCOUNT. FOR FURTHER CLARIFICATION PLEASE REVIEW THE SUPPLIERS LIST ATTACHED TO THIS ESTIMATE, OR CONSULT THE APPRAISER OR ESTIMATOR.

CCC PATHWAYS - A PRODUCT OF CCC INFORMATION SERVICES INC.

03/03/2005 AT 01:05 PM

JOB NUMBER: [REDACTED]

SUPPLEMENT OF RECORD 1 WITH SUMMARY
2005 HOND PILOT 4X4 EX 6-3.5L-FI 4D UTV B-533M-4 INT:GREY

NO.	OP.	DESCRIPTION	QTY	EXT.	PRICE	LABOR	PAINT
----- CHANGED ITEMS -----							
51#		SEAM SEALER	1		-15.00		
N 52#	S01	SEAM SEALER	1		15.00	0.5	
----- ADDED ITEMS -----							
56#	S01	FINAL BILL INDICATOR	1				
SUBTOTALS ==>					0.00	0.5	0.0

LINE 52 : LABOR TO MASK OFF FOR CAULK/SEAM SEAL

PARTS	0.00
ADDITIONAL SUPPLEMENT LABOR	25.00

SUBTOTAL	\$ 25.00
SALES TAX	\$ 25.00 @ 8.7500% 2.19

TOTAL SUPPLEMENT AMOUNT	\$ 27.19
NET COST OF SUPPLEMENT	\$ 27.19

ESTIMATE	1980.11	DAVID HERNANDEZ
SUPPLEMENT S1	27.19	WILLIAM ROTH

JOB TOTAL \$ 2007.30

INSURANCE PAY \$ 2007.30

THIS ESTIMATE IS BASED ON OUR INSPECTION AND DOES NOT COVER ADDITIONAL PARTS OR LABOR WHICH IS REQUIRED AFTER WORK HAS BEEN STARTED. AFTER WORK HAS BEEN STARTED, WORN OR DAMAGED PARTS WHICH WERE NOT EVIDENT ON FIRST INSPECTION MAY BE DISCOVERED. OUR MOTTO - QUALITY IS NOT RUSHED-WE DON'T SELL BODY WORK, WE SELL CONFIDENCE .

*** PART PRICES ARE SUBJECT TO DEALER INVOICES. PART PRICES MAY VARY FROM ORIGINAL ESTIMATE DUE TO ESTIMATING DATA BASE ERRORS***

ANY PERSON WHO KNOWINGLY AND WITH INTENT TO DEFRAUD ANY INSURANCE COMPANY OR OTHER PERSON FILES AN APPLICATION FOR COMMERCIAL INSURANCE OR A STATEMENT OF CLAIM FOR ANY COMMERCIAL OR PERSONAL INSURANCE BENEFITS CONTAINING ANY MATERIALLY FALSE INFORMATION, OR CONCEALS FOR THE PURPOSE OF MISLEADING, INFORMATION CONCERNING ANY FACT MATERIAL THERETO, AND ANY PERSON WHO, IN CONNECTION WITH SUCH APPLICATION OR CLAIM, KNOWINGLY MAKES OR KNOWINGLY ASSISTS, ABETS, SOLICITS OR CONSPIRES WITH ANOTHER TO MAKE A FALSE REPORT OF THE THEFT, DESTRUCTION, DAMAGE OR CONVERSION OF ANY MOTOR VEHICLE TO A LAW ENFORCEMENT AGENCY, THE DEPARTMENT OF MOTOR VEHICLES OR AN INSURANCE COMPANY, COMMITS A FRAUDULENT INSURANCE ACT, WHICH IS A CRIME, AND SHALL ALSO BE SUBJECT TO A CIVIL PENALTY NOT TO EXCEED FIVE THOUSAND DOLLARS AND THE VALUE OF THE SUBJECT MOTOR VEHICLE OR STATED CLAIM FOR EACH VIOLATION.

03/03/2005 AT 01:05 PM
12855

JOB NUMBER: 4385

SUPPLEMENT OF RECORD 1 WITH SUMMARY
2005 HOND PILOT 4X4 EX 6-3.5L-FI 4D UTV B-533M-4 INT:GREY

ESTIMATE BASED ON MOTOR CRASH ESTIMATING GUIDE. UNLESS OTHERWISE NOTED ALL ITEMS ARE DERIVED FROM THE GUIDE ARG4455 DATABASE DATE 02/2005, CCC DATA DATE 02/2005, AND THE PARTS SELECTED ARE OEM-PARTS MANUFACTURED BY THE VEHICLES ORIGINAL EQUIPMENT MANUFACTURER. OEM PARTS ARE AVAILABLE AT OE/VEHICLE DEALERSHIPS. ASTERISK (*) OR DOUBLE ASTERISK (**) INDICATES THAT THE PARTS AND/OR LABOR INFORMATION PROVIDED BY MOTOR MAY HAVE BEEN MODIFIED OR MAY HAVE COME FROM AN ALTERNATE DATA SOURCE. TILDE SIGN (~) ITEMS INDICATE MOTOR NOT-INCLUDED LABOR OPERATIONS. NON-ORIGINAL EQUIPMENT MANUFACTURER AFTERMARKET PARTS ARE DESCRIBED AS AM, QUAL REPL PARTS OR COMP REPL PARTS WHICH STANDS FOR COMPETITIVE REPLACEMENT PARTS. USED PARTS ARE DESCRIBED AS LKQ, QUAL RECY PARTS, RCY, OR USED. RECONDITIONED PARTS ARE DESCRIBED AS RECON. RECORED PARTS ARE DESCRIBED AS RECORE. NAGS PART NUMBERS AND PRICES ARE PROVIDED BY NATIONAL AUTO GLASS SPECIFICATIONS, INC. POUND SIGN (#) ITEMS INDICATE MANUAL ENTRIES. SOME PARTS THAT ARE DESCRIBED AS RECON. MAY BE OE SURPLUS PARTS OR OTHER OE PARTS OFFERED AT A SPECIAL PRICING DISCOUNT. FOR FURTHER CLARIFICATION PLEASE REVIEW THE SUPPLIERS LIST ATTACHED TO THIS ESTIMATE, OR CONSULT THE APPRAISER OR ESTIMATOR.

CCC PATHWAYS - A PRODUCT OF CCC INFORMATION SERVICES INC.

03/03/2005 AT 01:05 PM

JOB NUMBER: [REDACTED]

SUPPLEMENT OF RECORD 1 WITH SUMMARY
2005 HOND PILOT 4X4 EX 6-3.5L-FI 4D UTV B-533M-4 INT:GREY

ALTERNATE PARTS USAGE

AFTERMARKET PARTS

AFTERMARKET SELECTION METHOD: MANUALLY LIST

NO. OF TIMES USER WAS NOTIFIED THAT AN AFTERMARKET PART WAS AVAILABLE:	0
NO. OF AFTERMARKET PARTS THAT APPEAR IN THE FINAL ESTIMATE:	0

```
*****
*****
*****
***
***
***          06/13/06 07:31:12 AM          ***
***
*** Company          : Auto                  ***
*** Claim Number    : 32-V567-178          ***
*** Insured Name     : ██████████ ████████ ***
*** Requestor Name   : Steve Lollar        ***
*** Requestor Id     : QELZ                 ***
***
***
*** Total Number of Documents: 3           ***
***
*****
*****
*****
```



IMPORTS OF WANTAGH LTD.

3180 Sunrise Highway
Wantagh, N.Y. 11793
516-785-0300



PQO

PQO

CUSTOMER NO.	ADVISOR JIM	TAG NO. 104	INVOICE DATE 05/02/05
LABOR RATE 80.00	LICENSE NO.	MILEAGE OUT 20,067	COLOR TN/
YEAR / MAKE / MODEL 03/MAZDA/TRIBUTE	DELIVERY DATE	DELIVERY MILES	STOCK NO.
VEHICLE I.D. NO. 4 F 2 C Z 9 6 1 8 3 K	SELLING DEALER NO.	PRODUCTION DATE	
F.T.E. NO.	P.O. NO.	R.O. DATE 05/02/05	
RESIDENCE PHONE	BUSINESS PHONE	COMMENTS	MO:

LABOR & PARTS
104 MAZ CAMPAIGN HOURS: 0.40 TECH(S): 19 WARRANTY
CUSTOMER REQUESTS ACCEL CABLE RECALL
TECH INSTALLED RECALL PART

PARTS	QTY	FP NUMBER	DESCRIPTION	UNIT PRICE	WARRANTY
JOB # 1	1	EC05-41-660F	ACCEL CABL		
JOB # 1 TOTAL PARTS				0.00	
JOB # 1 TOTAL LABOR & PARTS				0.00	

TECHNICIAN CERTIFICATION
19 EDUARDO E. MORAN 19

TOTALS

TOTAL LABOR	0.00
TOTAL PARTS	0.00
TOTAL SUBLET	0.00
TOTAL G.O.G.	0.00
TOTAL MISC CHG.	0.00
TOTAL MISC DISC	0.00
TOTAL TAX	0.00
TOTAL INVOICE \$	0.00

N.Y.S. REG. REPAIR SHOP LIC. NO.
R1301223

ANY WARRANTIES ON THE PRODUCTS SOLD HEREBY ARE THOSE MADE BY THE MANUFACTURER. THE SELLER HEREBY EXPRESSLY DISCLAIMS EITHER EXPRESSED OR IMPLIED, INCLUDING ANY IMPLIED WARRANTY OF MERCHANTABILITY OR FITNESS FOR A PARTICULAR PURPOSE AND NEITHER ASSUMES NOR AUTHORIZES ANY OTHER PERSON TO ASSUME FOR IT ANY LIABILITY IN CONNECTION WITH THE SALE OF SAID PRODUCTS.

LABOR AND PARTS ARE WARRANTED FOR 6 MONTHS OR 6,000 MILES WHICHEVER OCCURS FIRST. THE DEALER HEREBY LIMITS ANY IMPLIED WARRANTIES OR MERCHANTABILITY AND FITNESS TO THE SAME PERIOD. WARRANTY REPAIRS TO BE PERFORMED AT THE SELLER'S PLACE OF BUSINESS.

THE FOLLOWING ARE NOT COVERED BY WARRANTY

FRONT-END ALIGNMENT, COOLANT AND COOLANT LEAKS, AIR CONDITIONING, SEAL LEAKS, POLISHES, ELECTRICAL WIRING AND SHORTS (WHEN NOT RELATED TO ORIGINAL REPAIR), FUEL SYSTEM WHEN DUE TO CONTAMINATION, TIRES AND BATTERIES WARRANTED AT MANUFACTURERS OPTION.



THIS WARRANTY DOES NOT COVER CONDITIONS RESULTING FROM MISUSE, NEGLIGENCE, ACCIDENT OR ALTERATIONS.

CUSTOMER SATISFACTION IS OUR NUMBER 1 CONCERN.

THANK YOU

FOR THIS OPPORTUNITY TO SERVE YOU. IT IS OUR AIM TO PERFORM ALL THE REPAIRS REQUESTED ON THIS REPAIR ORDER TO YOUR COMPLETE SATISFACTION. IF OUR SERVICE WAS SATISFACTORY TELL YOUR FRIENDS, IF NOT PLEASE TELL US IMMEDIATELY.

CUSTOMER SIGNATURE

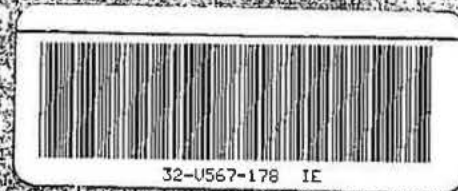
32-U567-178 IE

PAGE 1 OF 1

END OF INVOICE 109.33am

Rental Invoice



LYNBROOK NY

Rental Agreement - 2413

BILLING DETAIL		
Description	Rate	Amount
11 DAYS @	26.99	296.89
SALES TAX%	13.75	40.82

Bill To:
 0000251-00014/00025-F-24135124106
 STATE FARM-WAYNE CLAIMS CENTRAL
 ATTN: PROC*TEAM 4*
 300 KIMBALL DRIVE
 PARSIPPANY NJ 07054

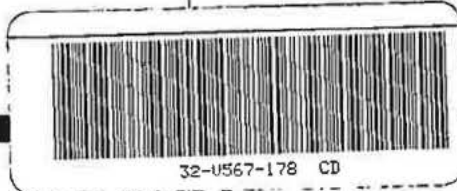

RENTAL INFORMATION	
Date Out 2/21/05	Date In 3/03/05
Renter LISA COHEN	

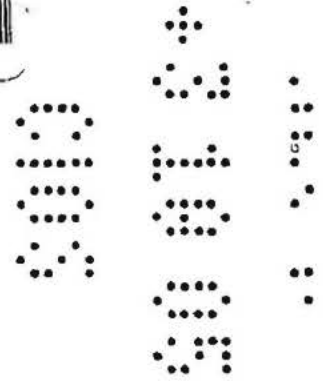

Additional Driver
Name
 NO OTHER DRIVER PERMITTED

AMOUNT DUE **337.71**

RENTAL VEHICLES		CLAIM INFORMATION	
Color GOLD	License No. [REDACTED]	Claim #/Policy #/P.O. # [REDACTED]	
Model 02 FOCU	Unit # NS2483	Insured [REDACTED]	
	Date of Loss 2/04/05	Type of Loss CLAIMANT	
	Type of Car HONDA PILO	Repair Shop MERRICK RD C	

IMPORTANT INFORMATION
Billing Inquiries Call [REDACTED]
Fed Tax ID #
 43-1487854
Billing Information

Thank You For Choosing Enterprise
 CONGRATS ENTERPRISE HONORED BY J.D.POWER
 AS NUMBER ONE IN CUSTOMER SERVICE FOR
 DOMESTIC AIRPORT OPERATIONS-4 YRS IN ROW



Please Return This Portion with Remittance

AMOUNT DUE **337.71**

Remit to:
 ENTERPRISE RENT-A-CAR
 ATTN: ACCTS RECEIVABLE
 3125 VETS MEMORIAL HWY STE 2
 RONKONKOMA NY 11779-7644

Paid by:
 STATE FARM-WAYNE CLAIMS CENTRAL
 ATTN: PROC*TEAM 4*
 300 KIMBALL DRIVE
 PARSIPPANY NJ 07054

03/07

Customer# [REDACTED] **Rental Agreement** [REDACTED] **Amount** 337.71 **GPBR** 2413

PE12-019

MADZA

9/6/2012

APPENDIX 3 SUBJECT

VEHICLES

DAMAGE CLAIM



**GREGORY A. GERMAIN
ATTORNEY AT LAW**

639 Jefferson Avenue
Scranton, Pennsylvania 18510

Telephone: (570) 341-1910
Facsimile: (570) 341-1903
Email: germainesq@aol.com

FAX**DATE: February 15, 2008****TO: Tim**
Mazda North American Operations**FAX NO: (949) 727-6592****FROM: Gregory A. Germain, Esq.****FAX NO: (570)341-1903****NO. OF
PAGES: 8****In Re:** [REDACTED]**VIN: 4F272941X4K** [REDACTED]**D.O.I:** [REDACTED]

Tim:

Thank you for your phone call this morning. As discussed I am attaching hereto the following documents:

Letter of settlement demand addressed to Mr. Mercer

Five photos of the cable preserved from the accident

The service manager at Bour Motors who confirmed that the cable was defective and caused the accident is Ed Frable 570-342-7831. Kindly direct the appropriate party at Mazda to respond to our demand in an effort to resolve my client's claim. Thank you for your attention and please call me with any questions in this regard.

Gregory A. Germain, Esquire

CONFIDENTIALITY NOTE: The documents accompanying this telecopy transmission contain information from an ATTORNEY/LEGAL COUNSEL, which is confidential and/or legally privileged. The information is intended only for the use of the individual or entity named on this transmission sheet. If you are not the intended recipient, you are hereby notified that any disclosure, copying, distribution or taking of any action in reliance on the contents of this telecopied information is strictly prohibited, and that the documents should be returned to this firm immediately. In this regard, if you have received this telecopy in error, please notify us by telephone immediately so that we can arrange for the return of the original documents to us at no cost to you.

**Gregory A. Germain
Attorney At Law**

636 Jefferson Avenue
Scranton, Pennsylvania 18510

Telephone: (570) 341-1910
Facsimile: (570) 341-1910

February 15, 2008

Robert B. Mercer
VP and General Counsel
Mazda North American Operations
7755 Irvine Center Dr.
Irvine, CA 92623

In Re: [REDACTED]
20 [REDACTED]
VIN: 4F272941X4K [REDACTED]
D.O.I: [REDACTED]

Dear Attorney Mercer:

I have been retained by Mrs. [REDACTED] to represent her with regard to vehicular accident which occurred on March 9, 2006. This will serve as our formal settlement demand.

I. Biographical Information

Mrs. [REDACTED] was born on March 21, 1953. She was married and [REDACTED] years old when her 2004 Mazda Tribute malfunctioned.

II. Summary of Occurrence

On the night of March 9, 2006 at approximately 7:30PM, the accelerator/cruise control cable in Mrs. [REDACTED] 2004 Tribute malfunctioned resulting in abnormal acceleration. Mrs. [REDACTED] was merging into traffic from the entrance ramp onto the Scranton Pennsylvania Expressway/McDade Expressway at North Main Avenue. Her 2004 Mazda Tribute dangerously accelerated beyond the speed of all surrounding traffic. Mrs. [REDACTED] attempts to brake and use the emergency brake were not successful in slowing down the automobile. My client was forced to drive for several miles on the shoulder of a busy expressway in order to avoid colliding with moving traffic in front of her. Mrs. [REDACTED] activated her flashers and used her car horn to caution other drivers of her precarious situation. Fearing for her life and that of other motorists, Mrs. [REDACTED] endeavored courageously to avoid contact with the guard rail because she assumed that any contact would launch her vehicle into the moving traffic. The guard rail ended before the Keyser Avenue exit and Mrs. [REDACTED] now traveling at approximately 100 miles per hour steered her automobile onto a large rock

embankment in an effort to reduce speed. Notwithstanding this extraordinary effort the 2004 Mazda Tribute continued moving at high speed and Mrs. [REDACTED] drove the vehicle towards the Keyser Avenue exit ramp. In a second attempt to reduce speed, my client braced herself for impact and aimed the automobile into a steep embankment on the left side of the exit ramp. The 2004 Mazda Tribute climbed the steep embankment and landed on the left side of the exit ramp where it finally stopped inches from the intersection of Keyser Avenue and the exit ramp. The automobile's defect could have resulted in numerous deaths and injuries. The automobile's defect did result in intense emotional trauma to my client.

III. Liability

It is our position that Mazda Corporation is liable for the emotional trauma and anxiety that Mrs. [REDACTED] sustained. My client purchased the 2004 Mazda Tribute from Bour Motors, Inc., a certified Mazda dealer, with the understanding that the automobile was safe to operate on public thoroughfares. Mrs. [REDACTED] regularly serviced the vehicle and is in no way responsible for the automobile malfunction. Furthermore, the 2004 Mazda Tribute was examined by the certified Mazda dealership and it was documented by the Bour Motors mechanic that the cruise control cable malfunctioned, resulting in the acceleration described above.

As the result of the defective nature of the cable and its housing, Mazda is strictly liable to my client pursuant to § 402A of the Restatement (Second) of Torts for the following reasons:

- (a) failing to properly and adequately design the cable system;
- (b) failing to properly and adequately manufacture or the cable system;
- (c) failing to warn my client of the dangerous nature of the cable system.

Furthermore, Mazda was negligent in:

- (a) failing to discover the defect in the cable system when it knew or should have known that such a defect existed;
- (b) failing to take steps necessary to repair the cable system; and
- (c) failing to properly test the cable system;

Furthermore, Mazda and /or its dealer, Bour Motors, Scranton, PA, breached warranties, both express and implied, by providing my client and her husband with a vehicle which was defective.

IV. Summary of Injuries

As a result of the vehicle malfunction, Mrs. [REDACTED] was subject to extremely unsafe driving conditions. My client was forced to purposely collide with two embankments in an effort to avoid harming other travelers on the expressway. Mrs. [REDACTED] managed to avoid contact with other vehicles. Mrs. [REDACTED] selflessly chose to direct her vehicle towards the embankments rather than remaining on the expressway so that the only injuries resulting from the malfunction would be injuries to her own body.

On March 9, 2006, Mrs. [REDACTED] was subjected to grossly abnormal stress levels. My client experienced indescribable anxiety for the duration of time she was inside the moving vehicle. Mrs. [REDACTED] along with countless other automobile operators, could have died or been seriously injured on the evening of March 9, 2006.

V. Damages

Mrs. [REDACTED] sustained contusions to her left knee which caused her substantial discomfort for about four months. Her left leg still bothers her occasionally especially in winter. Significantly, she also endured severe emotional trauma when her Mazda Tribute malfunctioned. My client was placed in the predicament of saving other travelers' lives by directing her car into steep embankments. Now, she experiences enhanced anxiety and fear every time she is in a moving vehicle. Mrs. [REDACTED] may have easily lost her life on March 9, 2006 while she was preventing the injuries and deaths of other expressway travelers.

Mrs. [REDACTED] was only [REDACTED] years old at the time of the vehicle malfunction, married, and very accustomed to operating a vehicle on public thoroughfares. She refused to operate a motor vehicle for almost a full year following the accident and continues to take anxiety medication as prescribed.

Prior to the accident on March 9, 2006 Mrs. [REDACTED] enjoyed worry-free mobility. Since March 9, 2006 she operates a vehicle with constant fear of malfunction. Even daily errands are dreaded as they require time in an automobile.

VI. Demand

Under Pennsylvania law Mrs. [REDACTED] is entitled to recovery for past, present and future discomfort, mental anguish and emotional distress. It is our reasonable belief that based on the clear liability of Mazda (**not considering punitive damages for failure to correct the design defect inherent to the acceleration cable and its housing**) our client would recover between a low award of \$50,000 and a high of \$125,000.00.

Based on research which evidences Mazda's experience and knowledge of the defective cable and cable housing in the 04' Tribute we would reasonably expect an award for punitive damages between a low of \$50,000 and a high of \$250,000.00.

The foregoing evaluation of the prospective jury award for actual damages recoverable sets forth a range from \$ 100,000.00 to \$375,000.00. The average of the High and Low is approximately \$237,500.00.

At this time, Mrs. [REDACTED] would demand that amount of \$75,000.00 to resolve this claim.

Kindly review this offer and respond to the same in the next ten (10) days. If you require further information to complete your review please feel free to contact my office at any time. The applicable statute of limitations is two years and failing a resolution before March 3, 2008 Mrs. [REDACTED] must file suit against Mazda.

Very truly yours,



Gregory A. Germain, Esq

Enclosures

cc: Mrs. [REDACTED] [REDACTED] [REDACTED]

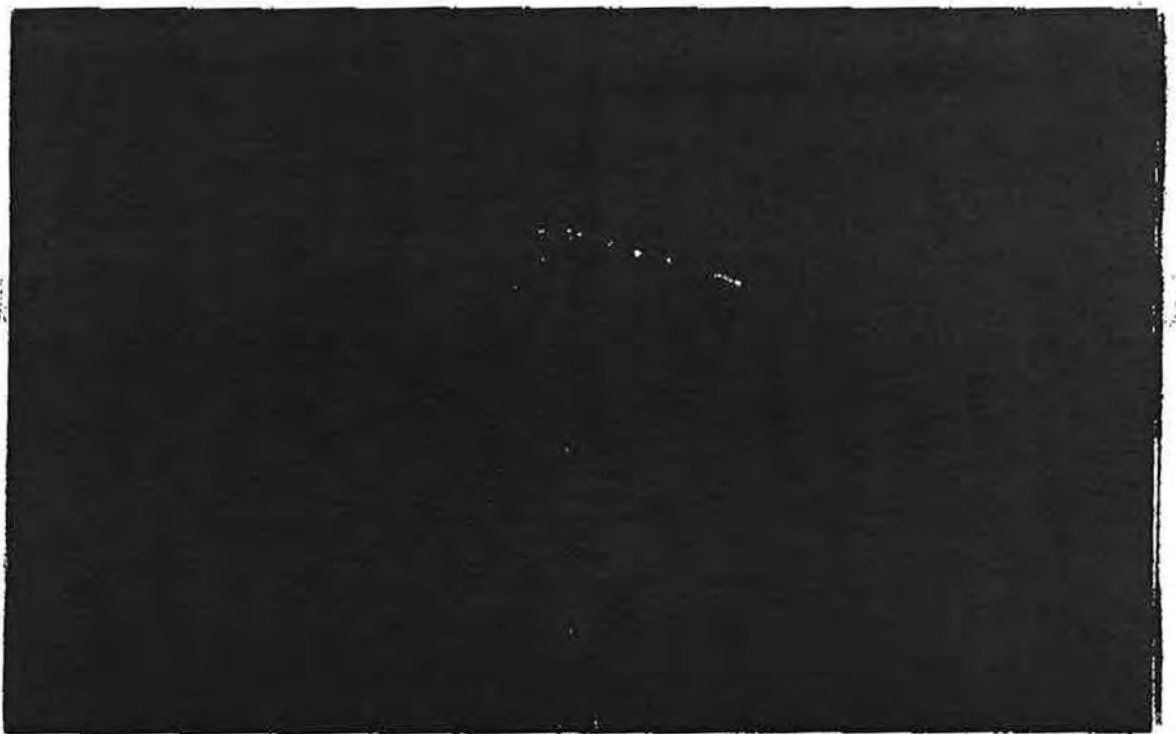

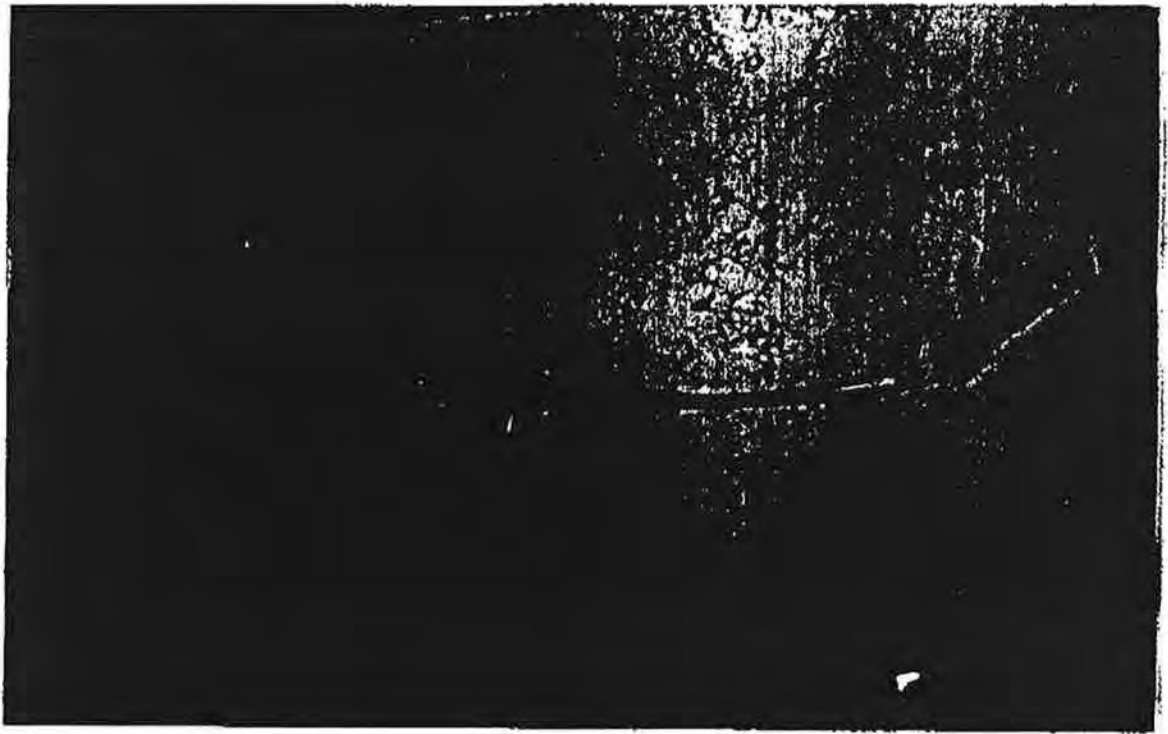



RECEIVED
FEB 12 2008
LEGAL DIVISION

**GREGORY A. GERMAIN
ATTORNEY AT LAW**

639 Jefferson Avenue
Scranton, Pennsylvania 18510

Telephone: (570) 341-1910
Facsimile: (570) 341-1903
Email: germainesq@aol.com

RECEIVED

FEB 13 2008

CUSTOMER MEDIATION

FAX

DATE: February 8, 2008

TO: Robert B. Mercer
VP and General Counsel
Mazda North American Operations

Damen

FAX NO: (949) 727-6101

FROM: Gregory A. Germain, Esq.

FAX NO: (570)341-1903

**NO. OF
PAGES:** 6

IN RE: [REDACTED] v. Mazda

Attached find letter of representation



Gregory A. Germain, Esquire

CONFIDENTIALITY NOTE: The documents accompanying this telecopy transmission contain information from an ATTORNEY/LEGAL COUNSEL, which is confidential and/or legally privileged. The information is intended only for the use of the individual or entity named on this transmission sheet. If you are not the intended recipient, you are hereby notified that any disclosure, copying, distribution or taking of any action in reliance on the contents of this telecopied information is strictly prohibited, and that the documents should be returned to this firm immediately. In this regard, if you have received this telecopy in error, please notify us by telephone immediately so that we can arrange for the return of the original documents to us at no cost to you.

Gregory A. Germain
Attorney at Law
639 Jefferson Avenue
Scranton, Pennsylvania 18510
Phone (570) 341-1910
Fax (570) 341-1903
germainesq@aol.com

February 11, 2008

Robert B. Mercer
VP and General Counsel
Mazda North American Operations
7755 Irvine Center Dr.
Irvine, CA 92623

In Re: [REDACTED]

VIN: 4F272941X4K [REDACTED]

D.O.I: [REDACTED]

Dear Attorney Mercer:

: Please be advised that I represent [REDACTED] in regard to a vehicle accident caused by a defective acceleration/cruise control cable in her 2004 Mazda Tribute. I am enclosing a copy of the Police Report for your file at this time.

Kindly refer this matter for immediate attention to your appropriate personnel or insurance carrier and advise them to direct all future correspondence to my office. My client has prepared a settlement demand and would like to resolve this claim by agreement and without litigation if possible.

Thank you for your attention in this regard

Very truly yours,

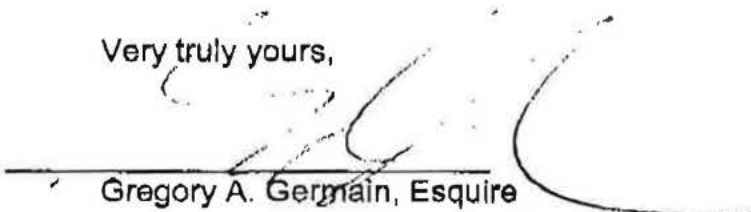

Gregory A. Germain, Esquire

cc: [REDACTED]

VIA FAX AND REGULAR MAIL

COMMONWEALTH OF PENNSYLVANIA POLICE CRASH REPORTING FORM



Crash Number

AA 500 1

Case Closed Yes No
Reportable Crash Yes No

Page



<input type="text" value="SCRANTON P. D."/>				Police Agency <input type="text" value="35302"/>	Patrol Zone <input type="text" value=""/>
Precinct				Investigation Date (MM-DD-YYYY) <input type="text" value="03-09-2006"/>	
Dispatch Time (mil) <input type="text" value="1939"/>	Arrival Time (mil) <input type="text" value="1942"/>	Investigator <input type="text" value="PTLM. MICHAEL ALBERT"/>	Badge Number <input type="text" value="00669"/>		
Reviewer <input type="text" value="COE, R. B. J."/>	Badge Number <input type="text" value="544"/>	Approval Date (MM-DD-YYYY) <input type="text" value="03-10-2006"/>			

County <input type="text" value="35"/>	County Name <input type="text" value="LACKAWANNA"/>	Municipality <input type="text" value="302"/>	Municipality Name <input type="text" value="SCRANTON"/>	Day of Week <input type="radio"/> Sun <input checked="" type="radio"/> Thu <input type="radio"/> Mon <input type="radio"/> Fri <input type="radio"/> Tue <input type="radio"/> Sat <input type="radio"/> Wed <input type="radio"/> Unk	
Crash Date (MM-DD-YYYY) <input type="text" value="03-09-2006"/>		Crash Time (mil) <input type="text" value="1939"/>	No of Units <input type="text" value="01"/>	People Injured <input type="text" value="01"/>	Killed* <input type="text" value="00"/>
Workzone (If Yes, Complete Form M, Section 29) <input type="radio"/> Yes <input checked="" type="radio"/> No		School Bus Related <input type="radio"/> Yes <input checked="" type="radio"/> No	School Zone Related <input type="radio"/> Yes <input checked="" type="radio"/> No	Notify PENNDOT Maintenance <input type="radio"/> Yes <input checked="" type="radio"/> No	

Intersection Type <input type="radio"/> 4 Way Intersection <input type="radio"/> *Y* Intersection <input type="radio"/> Multi-Leg Intersection <input checked="" type="radio"/> Off Ramp <input type="radio"/> Railroad Crossing <input type="radio"/> Midblock <input type="radio"/> *T* Intersection <input type="radio"/> Traffic Circle/ Round About <input type="radio"/> On Ramp <input type="radio"/> Crossover <input type="radio"/> Other		*Special Location <input type="text" value="02"/> * See Overlay			
Route Number <input type="text" value=""/>	Segment (Optional) <input type="text" value=""/>	Travel Lanes <input type="text" value="03"/>	Speed Limit <input type="text" value="25"/>	Orientation <input type="radio"/> North <input type="radio"/> South <input type="radio"/> East <input type="radio"/> West <input type="radio"/> Unknown	House Number (if applicable) <input type="text" value=""/>
Signaling <input type="radio"/> Interstate (Not Turnpike) <input type="radio"/> Turnpike (East/West) <input type="radio"/> Turnpike Spur <input checked="" type="radio"/> State Highway <input type="radio"/> County Road <input type="radio"/> Local Road or Street <input type="radio"/> Private Road <input type="radio"/> Other/Unknown					

Route Number <input type="text" value=""/>	Segment (Optional) <input type="text" value=""/>	Travel Lanes <input type="text" value="04"/>	Speed Limit <input type="text" value="25"/>	Orientation <input type="radio"/> North <input type="radio"/> South <input type="radio"/> East <input type="radio"/> West <input type="radio"/> Unknown	<input type="text" value="T"/>
Signaling <input type="radio"/> Interstate (Not Turnpike) <input type="radio"/> Turnpike (East/West) <input type="radio"/> Turnpike Spur <input type="radio"/> State Highway <input type="radio"/> County Road <input checked="" type="radio"/> Local Road or Street <input type="radio"/> Private Road <input type="radio"/> Other/Unknown					

Use For Mid-Block Crashes Please Enter Information for BOTH Landmarks if Using This Option	Landmark 1	Intersecting Rt Num Or Mile Post <input type="text" value=""/>	Or Segment Marker <input type="text" value=""/>	Ramp Use Only <input type="radio"/> North <input type="radio"/> South <input type="radio"/> East <input type="radio"/> West	Feet <input type="text" value=""/>
		Or Intersecting Street Name <input type="text" value=""/>	St Ending <input type="text" value=""/>		
	Landmark 2	Intersecting Rt Num Or Mile Post <input type="text" value=""/>	Or Segment Marker <input type="text" value=""/>	Ramp Use Only <input type="radio"/> North <input type="radio"/> South <input type="radio"/> East <input type="radio"/> West	Distance From Crash Scene to Landmark 1 (For Crash between Landmark 1 and Landmark 2) <input type="text" value=""/>
		Or Intersecting Street Name <input type="text" value=""/>	St Ending <input type="text" value=""/>		

Latitude: Degrees Minutes Seconds Longitude: Degrees Minutes Seconds

Traffic Control Device <input checked="" type="radio"/> Not Applicable <input type="radio"/> Traffic Signal <input type="radio"/> Active RR Crossing Controls <input type="radio"/> Flashing Traffic Signal <input type="radio"/> Stop Sign <input type="radio"/> Yield Sign <input type="radio"/> Police Officer or Flagman <input type="radio"/> Other Type TCD <input type="radio"/> Unknown		TCD Functioning <input checked="" type="radio"/> No Controls <input type="radio"/> Device Not Functioning <input type="radio"/> Device Functioning Improperly <input type="radio"/> Device Functioning Properly		Emergency Preemptive Signal <input type="radio"/> Unknown
--	--	--	--	--

Lane Closed (If "Not Applicable", skip rest of the Lane Closure section) <input checked="" type="radio"/> Not Applicable <input type="radio"/> Partially <input type="radio"/> Fully <input type="radio"/> Unknown	Lane Closure Direction <input type="radio"/> North <input type="radio"/> South <input type="radio"/> East <input type="radio"/> West <input type="radio"/> North and South <input type="radio"/> East and West <input type="radio"/> All (N,S,E,W)
---	---

Traffic Detoured Yes No Unknown
Esti. Time Closed < 30 Min. 30-60 Min. 1-3 hrs 3-6 hrs 6-9 hrs > 9 hours Unknown

COMMONWEALTH OF PENNSYLVANIA POLICE CRASH REPORTING FORM



Crash Number

AA 500 2

Police Use Only

Page:

02

UNIT INFO

Type Unit	<input checked="" type="radio"/> Motor Vehicle in Transport	<input type="radio"/> Hit & Run Vehicle	<input type="radio"/> Illegally Parked	<input type="radio"/> Legally Parked	<input type="radio"/> Non - Motorized	Commercial Vehicle <input type="radio"/> Yes <input checked="" type="radio"/> No <i>(If Yes, Complete Form C)</i>
	<input type="radio"/> Pedestrian	<input type="radio"/> Pedestrian on Skates, in Wheelchair, etc	<input type="radio"/> Disabled From Previous Crash	<input type="radio"/> Train	<input type="radio"/> Phantom Vehicle	

(If "Pedestrian" or "Pedestrian on Skates, in Wheelchair, etc", Complete Form M, Section 28)

Unit No	First Name	MI	Date of Birth (MM-DD-YY)
01	[REDACTED]	E	[REDACTED]
Delete?	Address / City / State		Telephone Number
<input type="radio"/>	[REDACTED]		[REDACTED]
Driver License Number		State	Class
[REDACTED]		PA	C

Alcohol/Drugs Suspected	Driver or Pedestrian Physical Condition
<input checked="" type="radio"/> No <input type="radio"/> Alcohol <input type="radio"/> Illegal Drugs <input type="radio"/> Alcohol and Drugs <input type="radio"/> Medication <input type="radio"/> Unknown	<input checked="" type="radio"/> Apparently Normal <input type="radio"/> Had Been Drinking <input type="radio"/> Illegal Drug Use <input type="radio"/> Sick <input type="radio"/> Fatigue <input type="radio"/> Asleep <input type="radio"/> Medication <input type="radio"/> Unknown

Alcohol Test Type	Primary Vehicle Code Violation	Charged?
<input checked="" type="radio"/> Test Not Given <input type="radio"/> Blood <input type="radio"/> Breath <input type="radio"/> Urine <input type="radio"/> Other <input type="radio"/> Unknown if Test Given	[REDACTED]	<input type="radio"/> Yes <input checked="" type="radio"/> No

Alcohol Test Results	Driver Presence
<input type="radio"/> Test Refused <input type="radio"/> Test Given, Contaminated Results <input type="radio"/> Unknown Results	<input checked="" type="radio"/> 1=Driver Operated Vehicle <input type="radio"/> 2=No Driver <input type="radio"/> 3=Driver fled Scene <input type="radio"/> 4=Hit and Run <input type="radio"/> 9=Unknown

Owner/Driver	00=Not Applicable	02=Private Vehicle Not Owned/Leased by Driver	04=State Police Vehicle	07=Municipal Police Veh	09=Federal Gov Veh
	01=Private Vehicle Owned/Leased by Driver	03=Rented Vehicle	05=PENNDOT Vehicle	08=Other Municipal Government Vehicle	98=Other
			06=Other State Gov Veh		99=Unknown

Same as Driver	Owner First Name	Owner Last Name or Business Name (If Pedestrian, skip this Section)
<input checked="" type="radio"/>	[REDACTED]	[REDACTED]

Address / City / State / Zip	Vehicle Make	*Make Code
[REDACTED]	MAZDA	41
VIN	Model Year	Vehicle Model
4F242941X4K [REDACTED]	2004	TRIBUTE
License Plate	Reg. State	Est. Speed
[REDACTED]	PA	[REDACTED]
Insurance	Insurance Company	Policy No
<input checked="" type="radio"/> Yes <input type="radio"/> No <input type="radio"/> Unknown	STATE FARM	[REDACTED]

Trailing Unit	Type Unit	Tag No	Tag Year	Tag St
<input type="radio"/> No. of Trailing Units: 0	<input type="checkbox"/> 1=Towing Pass. Veh <input type="checkbox"/> 2=Towing Truck <input type="checkbox"/> 3=Towing Utility Trailer <input type="checkbox"/> 4=Mobile/Modular Home <input type="checkbox"/> 5=Camper <input type="checkbox"/> 6=Full Trailer <input type="checkbox"/> 7=Semi-Trailer <input type="checkbox"/> 8=Other <input type="checkbox"/> 9=Unknown	[REDACTED]	[REDACTED]	[REDACTED]

Direction of Travel	*Vehicle Position	*Movement	*See Overlay	Special Usage
N	01	01		00
Vehicle Color	Vehicle Type	05=Large Truck	20=Unicycle, Bicycle, Tricycle	12=Commercial Passenger Carrier
02	04	06=SUV	21=Other Pedalcycle	13=Taxi
01=Blue 02=Red 03=White 04=Green 05=Black	01=Automobile 02=Motorcycle 03=Bus 04=Small Truck <i>(If "02", Complete Form M, Section 26)</i> <i>(If "20" or "21", Complete Form M, Section 27)</i>	07=Van 10=Snowmobile 11=Farm Equip 12=Construction Equip 13=ATV 18=Other Type Spec Veh 19=Unk. Type Spec Veh	22=Horse & Buggy 23=Horse & Rider 24=Train 25=Trolley 98=Other 99=Unknown	00=Not Applicable 01=Fire Veh 02=Ambulance 03=Police 08=Other Emergency Vehicle 11=Pupil Transport

Initial Impact Point	Damage Indicator	Gradient	Road Alignment
01	2	3	1
00=Non-Collision 01-12=Clock Points 13=Top	0=None 2=Functional 1=Minor 3=Disabling 9=Unknown	1=Level 2=Uphill	1=Straight 2=Curved 9=Unknown

VEHICLE DRIVER / PASSENGER INFORMATION

COMMONWEALTH OF PENNSYLVANIA POLICE CRASH REPORTING FORM



Crash Number

AA 500 3

Police Use Only

Page

03

people information

- A Person Type:**
 1=Driver
 2=Passenger
 7=Pedestrian
 8=Other
 9=Unknown

- B Sex:**
 F=Female
 M=Male
 U=Unknown

- C Injury Severity:**
 0=Not Injured
 1=Killed
 2=Major Injury
 3=Moderate Injury
 4=Minor Injury
 8=Injury, Unk Severity
 9=Unknown if Injury

- D Seat Position:**
 00=Not A Passenger/Occupant
 01=Driver - All Vehicles
 02=Front Seat Middle Position
 03=Front Seat Right Side
 04=Second Row - Left Side Or Motorcycle Passenger
 05=Second Row - Middle Position
 06=Second Row - Right Side
 07=Third Row Or Greater - Left Side
 08=Third Row Or Greater - Middle Position
 09=Third Row Or Greater - Right Side
 10=Sleeper Section of Truckcab
 11=In Other Enclosed Passenger Or Cargo Area
 12=In Open Area (Back Of Pickup, Etc.)
 13=Trailing Unit
 14=Riding On Vehicle Exterior
 15=Bus Passenger
 98=Other
 99=Unknown

- E Safety Equipment One:**
 00=None Used / Not Applicable
 01=Shoulder Belt Used
 02=Lap Belt Used
 03=Lap And Shoulder Belt Used
 04=Child Safety Seat Used
 05=Motorcycle Helmet Used
 06=Bicycle Helmet Used
 10=Safety Belt Used Improperly
 11=Child Safety Seat Used Improperly
 12=Helmet Used Improperly
 90=Restraint Used, Type Unknown
 99=Unknown

- F Safety Equipment Two:**
 00=None Used / Not Applicable
 01=Front Air Bag Deployed (For This Seat)
 02=Side Air Bag Deployed (For This Seat)
 03=Other Type Air Bag Deployed
 04=Multiple Air Bags Deployed
 05=Motorcycle Eye Protection
 06=Bicyclist Wearing Elbow/Knee/Pads
 10=Air Bag Not Deployed, Switch On
 11=Air Bag Not Deployed, Switch Off
 12=Air Bag Not Deployed, Unk Switch Setting
 13=Air Bag Removed (Prior To Crash)
 19=Unknown If Air Bag Deployed
 99=Unknown

- G Ejection:**
 0=Not Applicable
 1=Not Ejected
 2=Totally Ejected
 3=Partially Ejected
 9=Unknown

- H Ejection Path:**
 0=Not Ejected / Not Applicable
 1=Through Side Door Opening
 2=Through Side Window
 3=Through Windshield
 4=Through Back Door
 5=Through Back Door Tailgate Opening
 6=Through Roof Opening (Sunroof/Convertible Top Down)
 7=Through Roof Opening (Convertible Top Up)
 9=Unknown

- I Extrication:**
 0=Not Applicable
 1=Not Extricated
 2=Extricated By Mechanical Means
 3=Extricated By Non - Mechanical Means
 8=Other
 9=Unknown

EMS Agency:

Medical Facility:

Unit No	Person No	Delete?	Date	A	B	C	D	E	F	G	H	I
01	01	<input type="radio"/>		1	F	0	0	1	9	9	1	2

Name / Address / Phone

EMS Transport

Same as Operator

Yes No

Unit No	Person No	Delete?	Date of Birth (MM-DD-YYYY)	A	B	C	D	E	F	G	H	I
		<input type="radio"/>										

Name / Address / Phone

EMS Transport

Same as Operator

Yes No

Unit No	Person No	Delete?	Date of Birth (MM-DD-YYYY)	A	B	C	D	E	F	G	H	I
		<input type="radio"/>										

Name / Address / Phone

EMS Transport

Same as Operator

Yes No

Unit No	Person No	Delete?	Date of Birth (MM-DD-YYYY)	A	B	C	D	E	F	G	H	I
		<input type="radio"/>										

Name / Address / Phone

EMS Transport

Same as Operator

Yes No

Unit No	Person No	Delete?	Date of Birth (MM-DD-YYYY)	A	B	C	D	E	F	G	H	I
		<input type="radio"/>										

Name / Address / Phone

EMS Transport

Same as Operator

Yes No

Unit No	Person No	Delete?	Date of Birth (MM-DD-YYYY)	A	B	C	D	E	F	G	H	I
		<input type="radio"/>										

Name / Address / Phone

EMS Transport

Same as Operator

Yes No

COMMONWEALTH OF PENNSYLVANIA POLICE CRASH REPORTING FORM



Crash Number

AA 500 4

Police Use Only

Page

04

General Crash Information (If more than 2 Units, complete one)

Crash Description	4	0=Non-Collision 1=Rear End	2=Head On 3=Rear to Rear (Backing)	4=Angle 5=Slideswipe (Same Direction)	6=Slideswipe (Opposite Direction) 7=Hit Fixed Object	8=Hit Pedestrian 9=Other/Unknown
Relation to Roadway	2	1=On Travel Lanes 2=Shoulder	3=Median 4=Roadside	5=Outside Trafficway 6=In Parking Lane	7=Gore (Ramp Intersection) 9=Unknown	
Illumination	3	1=Daylight 2=Dark - No Street Lights	3=Dark - Street Lights 4=Dusk	5=Dawn 6=Dark - Unknown Roadway Lighting	6=Other	
Weather Conditions	1	1=No Adverse Conditions 2=Rain	3=Sleet (Hail) 4=Snow	5=Fog 6=Rain & Fog	7=Sleet & Fog 8=Other	9=Unknown
Road Surface Conditions	0	0=Dry 1=Wet	2=Sand, Mud, Dirt, Oil 3=Snow Covered	4=Slush 5=Ice	6=Ice Patches 7=Water - Standing or Moving	8=Other

Harmful Events (Harmful Events)

Unit No	Harm Event	L/R	Most?	Utility Pole Number
1	25			
01				
2				
3				
4				

Unit No	Harm Event	L/R	Most?	Utility Pole Number
1				
2				
3				
4				

Unit No	Harm Event	Most Harmful Event In the Crash
01	25	25

Do not repeat this information on multiple pages

Environmental / Roadway Potential Factors (E/R)

1	00	2	00	3	00
---	----	---	----	---	----

00=None
01=Windy Conditions
02=Sudden Weather Conditions
03=Other Weather Conditions
04=Deer In Roadway
05=Obstacle On Roadway
06=Other Animal In Roadway
07=Glare
08=Work Zone Related
11=Slippery Road Conditions (Ice/Snow)
12=Substance On Roadway
13=Potholes
14=Broken Or Cracked Pavement
15=TCO Obstructed
16=Soft Shoulder Or Shoulder Drop Off
28=Other Roadway Factor
29=Other Environmental Factor
99=Unknown

Possible Vehicle Failures (V)

00=None	06=Exhaust	12=Wipers
01=Tires	07=Headlights	13=Driver Seating/Control
02=Brake System	08=Signal Lights	14=Body, Doors, Hood, Etc
03=Steering System	09=Other Lights	15=Trailer Hitch
04=Suspension	10=Horn	16=Wheels
05=Power Train	11=Mirrors	17=Airbags
		18=Trailer Overloaded
		19=Unsecure/Shifted Trailer Load
		20=Improper Towing
		21=Obstructed Windshield
		99=Unknown

Indicated Prime Factor

Do not repeat this information on multiple pages.

E/R	V	D	P
0	0	0	0

Unit No: 01 Factor Code: 00

If E/R is the Prime Factor Type, leave Unit No blank

Harmful Events (Harm Event)

01=Hit Unit 1
02=Hit Unit 2
03=Hit Unit 3
04=Hit Unit 4
05=Hit Unit 5
06=Hit Other Traffic Unit
07=Hit Deer
08=Hit Other Animal
09=Collision With Other Non Fixed Object
11=Struck By Unit 1
12=Struck By Unit 2
13=Struck By Unit 3
14=Struck By Unit 4
15=Struck By Unit 5
16=Struck By Other Traffic Unit
21=Hit Tree Or Shrubbery
22=Hit Embankment
23=Hit Utility Pole
24=Hit Traffic Sign
25=Hit Guard Rail
26=Hit Guard Rail End
27=Hit Curb
28=Hit Concrete Or Longitudinal Barrier
29=Hit Ditch
30=Hit Fence Or Wall
31=Hit Building
32=Hit Culvert
33=Hit Bridge Pier Or Abutment
34=Hit Parapet End
35=Hit Bridge Rail
36=Hit Boulder Or Obstacle On Roadway
37=Hit Impact Attenuator
38=Hit Fire Hydrant
39=Hit Roadway Equipment
40=Hit Mail Box
41=Hit Traffic Island
42=Hit Snow Bank
43=Hit Temporary Construction Barrier
48=Hit Other Fixed Object
49=Hit Unknown Fixed Object
50=Overturn/Roll Over
51=Struck By Thrown Or Falling Object
52=Pot Holes Or Other Pavement Irregularities
53=Jackknife
54=Fire In Vehicle
58=Other Non-Collision
99=Unknown Harmful Event

Driver Action (D)

00=No Contributing Action
01=Driver Was Distracted
02=Driving Using Hand Held Phone
03=Driving Using Hands Free Phone
04=Making Illegal U-Turn
05=Improper/Careless Turning
06=Turning From Wrong Lane
07=Proceeding W/O Clearance After Stop
08=Running Stop Sign
09=Running Red Light
10=Failure To Respond To Other Traffic Control Device
11=Tailgating
12=Sudden Slowing/Stopping
13=Illegally Stopped On Road
14=Careless Passing Or Lane Change
15=Passing In No Passing Zone
16=Driving The Wrong Way On 1-Way Street
17=Careless Or Illegal Backing On Roadway
18=Driving On The Wrong Side Of Road
19=Making Improper Entrance To Highway
20=Making Improper Exit From Highway
21=Careless Parking/Unparking
22=Over/Under Compensation At Curve
23=Speeding
24=Driving Too Fast For Conditions
25=Failure To Maintain Proper Speed
26=Driver Fleeing Police (Poi Chase)
27=Driver Inexperienced
28=Failure To Use Specialized Equip
92=Affected By Physical Condition
98=Other Improper Driving Actions
99=Unknown

Unit No	01	1	00	2	00	3	00	4	00
Unit No		1		2		3		4	

Pedestrian Action (P)

00=None
01=Entering Or Crossing At Specified Location
02=Walking, Running, Jogging, Or Playing
03=Working
04=Pushing Vehicle
05=Approaching Or Leaving Vehicle
06=Working On Vehicle
07=Standing
98=Other
99=Unknown

Unit No: 01 00 Unit No:

COMMONWEALTH OF PENNSYLVANIA
POLICE CRASH REPORTING FORM



Crash Number

AA 500 5

Police Use Only

Page

05

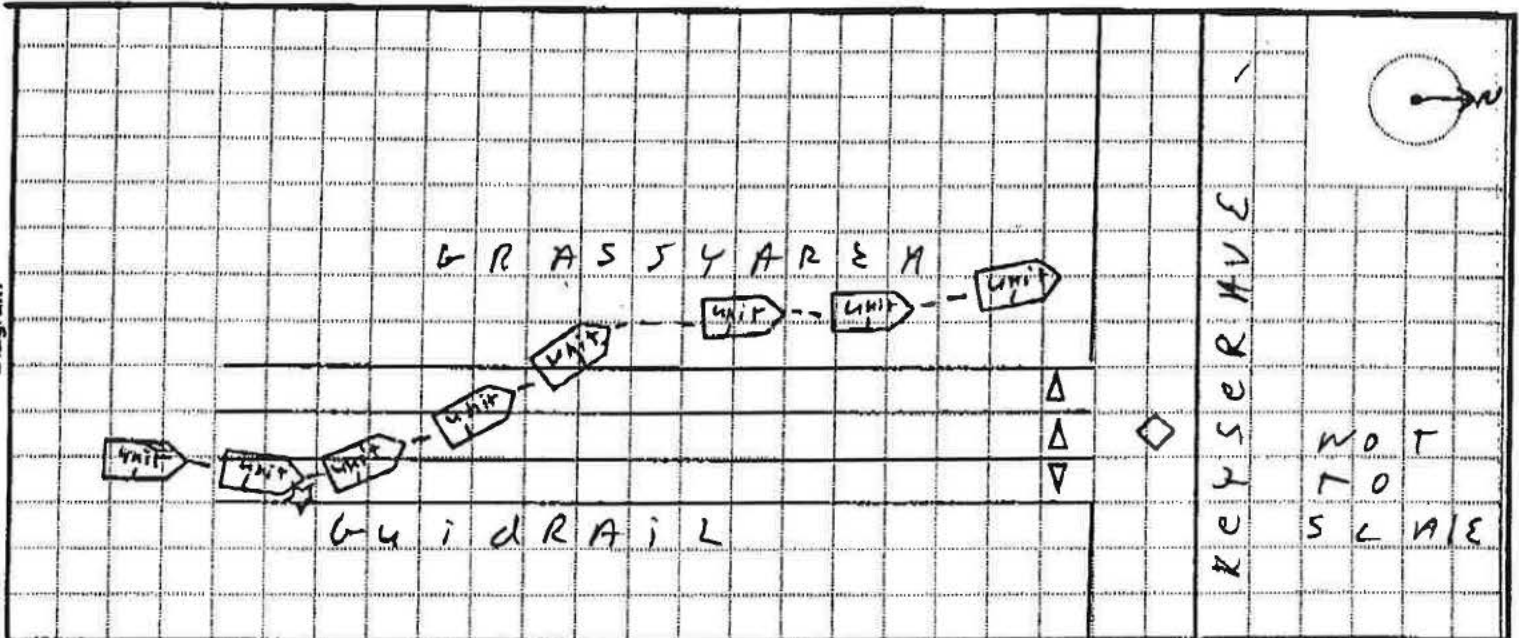

Witness Name	Address	Phone
1 [REDACTED]	[REDACTED] SCR. PA	[REDACTED]
2		

Narrative and additional witnesses: Accident Investigation Notification Issued? Property Damage

ON THE ABOVE DATE AND TIME I RESPONDED TO THE 1200 BLOCK OF KEYSER AVE. FOR A VEHICLE THAT RAN OFF THE ROAD AND ON FIRE. UPON MY ARRIVAL THE ACCIDENT OCCURED ON THE KEYSER AVE. OFF RAMP FROM THE SCRANTON EXPRESSWAY. I SPOKE TO MARYCLARE SWARTS (DRIVER UNIT #1) WHO STATED SHE WAS TRAVELING NORTH ON THE EXPRESSWAY AND EXITED THE KEYSER AVE EXIT WHEN HER BRAKES FAILED. UNIT #1 STATED SHE HIT GUARD RAIL AND CROSSED THREE LANES AND INTO THE GRASSY AREA LEFT OF THE OFF RAMP. THE VEHICLE WAS NOT ON FIRE BUT WAS SMOKING HEAVILY BECAUSE OF THE BRAKES LOCKING UP. NO INJURIES TO THIS ACCIDENT.

PE12-019

MADZA

9/6/2012

APPENDIX 3 SUBJECT
VEHICLES

DAMAGE CLAIM



K.B.



Erie Insurance®

Bruce E. Peterson, AIC
Vice President & Claims Manager

Claims Office • 18544 Breeze Hill Drive • P.O. Box 4158 • Hagerstown, MD 21741-4158
301.797.5185 • Toll free 1.800.533.5602 • Fax 301.714.9218 • www.erieinsurance.com

April 7, 2009

Darcars Imports, Inc.
Attn: Stan in Service
12511 Prosperity Drive
Silver Spring, MD 20904

Mazda North American Operations
Customer Mediation Department
7755 Irvine Center Drive
Irvine, CA 92618

RE: Erie Insured: [REDACTED]
Claim #: [REDACTED]
Loss Date: 03/28/2009
Vehicle: 2002 Mazda Tribute LX
VIN: 4F2CU08102K [REDACTED]

RECEIVED

APR 28 2009

CUSTOMER MEDIATION

Dear Service Manager,

Our insured Ms. [REDACTED] was involved in a motor vehicle accident on 3/28/2009. While driving her 2002 Mazda Tribute her check engine light came on. She stopped at a red light in which she was going to turn around and pull off the road. While stopped at the red light, the engine began revving and suddenly and without warning her airbags went off and she was into the rear of the vehicle in front of her.

Erie checked her VIN for any recalls and located recall # 2704L which matched up to a recall she had completed at your facility on 2/10/2005.

Erie has requested an engineer complete an inspection of the vehicle to determine the cause of the sudden acceleration. The engineer has recommended a representative from the dealership and Mazda be present.

Please contact me at your **earliest** convenience to coordinate an inspection time with the engineering company. The vehicle is currently located at Insurance Auto Auctions at 14149 Brandywine Road, Brandywine, MD 20613.

Thank you for your time.

Sincerely,

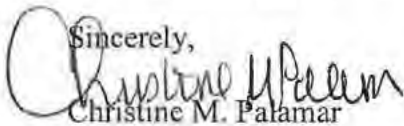

Christine M. Palamar
Claim Adjuster, III
(866) 558-6076
(301) 824-2807 (fax)
PO Box 3515
Hagerstown, MD 21742

Cc: [REDACTED]



ChoicePoint Police Records
P.O.Box 740167
Atlanta, GA 30374-0167
Phone: 1.800.934.9698 Fax 1.800.934.6449
Email: orderpoint.support@choicepoint.com

REPORT ATTACHED

PAGE COUNT: 2

CLIENT : [REDACTED]
DIVISION : 022
ADJUSTER : A812MDAPV21
CLAIM : [REDACTED]

TRANSACTION # : [REDACTED]
DATE : 04/16/2009

DATE OF LOSS : 03/28/2009 TIME OF LOSS : 05:00 PM
STREET : HICKORY RIDGE AND CEDAR_LANE
CITY : COLUMBIA
COUNTY : HOWARD
STATE : MD

INVESTIGATING AGENCY : HOWARD CO PD
REPORT NUMBER : 09031212
REPORT TYPE : Auto Accident
PARTY 1 : [REDACTED]
PARTY 2 : [REDACTED]
PARTY 3 : [REDACTED]

CAR : 4 DOOR MAKE : MAZD YEAR : 2002
TAG : [REDACTED]

DRIVER LICENSE : [REDACTED]
ADDITIONAL INFO :

NOTE :

State of Maryland Motor Vehicle Accident Report

REPORT NO. [REDACTED]		1. INJURY	2. ACCIDENT DATE	3. ACCIDENT TIME	4. REPORT TYPE	5. RESEARCH	6. LOCAL CASE NUMBER	7. LOCAL CODES	8. INJURY	9. INJURY													
INVESTIGATING OFFICER ID Rosebraun 5566		10. AGENCY AND AREA	11. SUPERVISING OFFICER ID	12. REVIEWER	13. CODE AND NAME OF MUNICIPALITY		14. COUNTY		15. COUNTY														
16. RD CHAR	17. RTE NUM	18. ROAD NAME		19. IN LANE	20. TRAF SIG	21. ON RAMP	22. Ramp Number (Direction)		23. D-Not Ramp	24. IN INTERSECTION													
01	C000082	Cedar Lane		5L	YES	NO	1 N-W 2 W-N 3 E-W 4 N-E		NO	NO													
25. INT-RTE	26. INTERSECTING ROAD NAME or Log Mile Reference Manual description.		27. MILEPT		28. DIR		29. Dist. of Acc to INT-RTE/Ref & Dir.		30. INJURY														
01	C0014571 Hickory Ridge Road		21012N		101000		101000		S														
31. ACCIDENT DIAGRAM				32. DESCRIBE ACCIDENT briefly; identify units by numbers. Also identify the following as the OBJECT DAMAGED & NATURE OF DAMAGE (Property other than vehicle) and by the NAME & ADDRESS OF OWNER when applicable.																			
				Vehicle 2 was stopped in the left turn lane on Cedar Lane waiting to turn onto Hickory Ridge. Vehicle 1 was behind Vehicle 2 also in the left turn lane. Driver of vehicle 1 stated her "check engine" light came on and when she attempted to apply the break in response to her engine revving unexpectedly she accidentally hit the gas pedal. Vehicle 1 then rear ended vehicle 2.																			
33. UNIT #		34. SLX		35. UNIT #		36. NAME (First, Middle, Last)		37. UNIT #		38. NAME (First, Middle, Last)													
01		02		02		[REDACTED]		02		[REDACTED]													
39. ADDRESS (No. Street City, State, Zip)				40. TYPE				41. ADDRESS (No. Street City, State, Zip)				42. TYPE											
Mount Airy MD				A				Ellicott City MD				A											
43. MOVEMENT		44. CONDITN		45. SUBST		46. TEST		47. RESULT		48. FOR PDS ONLY		49. AGE		50. TYPE		51. LOCATN		52. OBY		53. VISBL			
02		01		01		01		01		01		01		01		01		01		01			
54. SPEED LIMIT		55. SAF. EQU.		56. EQ PROB		57. FICT		58. (CITATION NUMBER(S))		59. SPEED LIMIT		60. SAF. EQU.		61. EQ PROB		62. FICT		63. (CITATION NUMBER(S))		64. FAULT			
35		32		01		01		01		35		32		01		01		01		NO			
65. COINC.		66. DRIVER'S LICENSE NUMBER		67. CLASS		68. COINC.		69. DRIVER'S LICENSE NUMBER		70. CLASS		71. COINC.		72. DRIVER'S LICENSE NUMBER		73. CLASS		74. COINC.		75. DRIVER'S LICENSE NUMBER			
02		[REDACTED]		M.D.		02		[REDACTED]		M.D.		02		[REDACTED]		M.D.		02		[REDACTED]			
76. CONTIN.		77. DR DATE OF BIRTH		78. IRREGULAR CONDITION		79. HMI SPILL		80. HAZ MAT NUMBER		81. CONTIN.		82. DR DATE OF BIRTH		83. IRREGULAR CONDITION		84. HMI SPILL		85. HAZ MAT NUMBER		86. CONTIN.			
03		01		NO		NO		0		03		01		NO		NO		0		03			
87. BODY TY		88. COMM. VEHICL ONLY		89. U. S. DOT NUMBER		90. IC# NUMBER		91. BODY TY		92. COMM. VEHICL ONLY		93. U. S. DOT NUMBER		94. IC# NUMBER		95. BODY TY		96. COMM. VEHICL ONLY		97. U. S. DOT NUMBER			
02		NO		[REDACTED]		[REDACTED]		20		NO		[REDACTED]		[REDACTED]		20		NO		[REDACTED]			
98. OWNER OR CARRIER NAME (When "SAME" if Driver)				99. TEL				100. MOST IIE				101. OWNER OR CARRIER NAME (When "SAME" if Driver)				102. TEL							
Same				[REDACTED]				01				[REDACTED]				[REDACTED]							
103. CONTRIB CIRCUMSTANCES				104. OWNER/CARRIER ADDRESS				105. CONTRIB CIRCUMSTANCES				106. OWNER/CARRIER ADDRESS				107. CONTRIB CIRCUMSTANCES				108. OWNER/CARRIER ADDRESS			
5.9				Same				01				Ellicott City MD				01				Ellicott City MD			
109. YEAR & MAKE OF VEHICLE		110. MODIF		111. YEAR & MAKE OF VEHICLE		112. MODIF		113. YEAR & MAKE OF VEHICLE		114. MODIF		115. YEAR & MAKE OF VEHICLE		116. MODIF		117. YEAR & MAKE OF VEHICLE		118. MODIF		119. YEAR & MAKE OF VEHICLE			
07		021 Mazda		05 Tribute		07		02 Toyota		05 Tacoma		07		02 Toyota		05 Tacoma		07		02 Toyota			
120. EXP YR & REGISTR # STATE		121. AKA/S DAMAGED		122. INSURER		123. EXP YR & REGISTR # STATE		124. AKA/S DAMAGED		125. INSURER		126. EXP YR & REGISTR # STATE		127. AKA/S DAMAGED		128. INSURER		129. EXP YR & REGISTR # STATE		130. AKA/S DAMAGED			
00		09 M726734MD		010203		00		01077204MD		091101		00		01077204MD		091101		00		01077204MD			
131. VEHICLE ID NUMBER		132. POLICY NUMBER		133. VEHICLE ID NUMBER		134. POLICY NUMBER		135. VEHICLE ID NUMBER		136. POLICY NUMBER		137. VEHICLE ID NUMBER		138. POLICY NUMBER		139. VEHICLE ID NUMBER		140. POLICY NUMBER		141. VEHICLE ID NUMBER			
00		4F2C008102K		[REDACTED]		00		5TEWM72N7Z		[REDACTED]		00		5TEWM72N7Z		[REDACTED]		00		5TEWM72N7Z			
142. VEHICLE REMOVED BY		143. VEHICLE REMOVED TO		144. VEHICLE REMOVED BY		145. VEHICLE REMOVED TO		146. VEHICLE REMOVED BY		147. VEHICLE REMOVED TO		148. VEHICLE REMOVED BY		149. VEHICLE REMOVED TO		150. VEHICLE REMOVED BY		151. VEHICLE REMOVED TO		152. VEHICLE REMOVED BY			
04		Bill's Towing		03		Bill's Towing		03		03		Bill's Towing		03		03		03		03			
153. TRAFIC UNIT #		154. SEATING POSITION		155. CODE of injured/injured PASSENGERS below. Use "W" for witness in TRAFIC UNIT and SEAT columns		156. WITNESS NAME & ADDRESS of Injured Passengers and Witnesses.		157. Witness telephone #		158. SEX		159. AGE		160. SALLY EQUIP		161. EQUIP PROB		162. INJUR SEVER		163. ELEC-TION		164. LMS UNIT	
02		03		[REDACTED]		[REDACTED]		[REDACTED]		M		03		3.2		0.1		0.1		0.1			
165. INJURED TAKEN BY:		166. INJURED TAKEN TO:		167. EMS RUN REPORT #		168. INJURED TAKEN BY:		169. INJURED TAKEN TO:		170. EMS RUN REPORT #		171. INJURED TAKEN BY:		172. INJURED TAKEN TO:		173. EMS RUN REPORT #		174. INJURED TAKEN BY:		175. INJURED TAKEN TO:		176. EMS RUN REPORT #	
A97 HCFR A-96		Howard County Garage		09-7310		A97 HCFR A-96		Howard County Garage		09-7310		A97 HCFR A-96		Howard County Garage		09-7310		A97 HCFR A-96		Howard County Garage		09-7310	





PE12-019

MADZA

9/6/2012

APPENDIX 3 SUBJECT
VEHICLES

DAMAGE CLAIM





FARMERS'

National Document Center
P. O. Box 268992
Oklahoma City, OK 73126-8992
claimsdocuments@hpcs.com
Fax: 877-217-1389
Toll Free: 800-HelpPoint

08/08/2011

Mazda North American Operations
Attn: Customer Assistance Center
P.O. Box 19734
Irvine, CA 92623-9734

Our Insured: [REDACTED]
Our Claim #: [REDACTED]
Date of Loss: 01/13/2010
Your Claim #:
Deductible Amount: \$0.00
Total Amount Owed: \$33,895.70

RECEIVED
AUG 16 2011
CUSTOMER MEDIATION

Dear Customer Assistance Center,

Our initial investigation has established that the above loss may have been caused by the malfunction of your product.

She advised she had backed out of her driveway, put vehicle in drive, had foot on brake and vehicle raced backwards and into neighbor's house across the street.

We are in the process of making payment to our insured for their damages. By virtue of our subrogation rights we shall seek reimbursement from you for the amount of the damages.

Please be aware that no payment that is less than the full amount claimed herein will be considered in any way an acceptance of benefits, a novation or an accord and satisfaction of this claim without an express written release of our claim executed by an individual who identifies himself/herself as a member of our subrogation department. Therefore, our legal rights to enforce collection on the remaining amount of the claim shall not be waived or stopped due to partial payment by you or someone acting on your behalf.

We can discuss this matter with your representative. Please supply the name, phone number and file number of your representative contact.

Sincerely,
Mid-Century Insurance Company

Morgan Pattermann
Litigation Claims Representative
630-907-6942

NE

MISSOURI UNIFORM ACCIDENT REPORT

PAGE 1 OF 4

SPACE USED FOR BARCODE		AGENCY NAME AND ORI ST. PETERS POLICE DEPARTMENT H00930100			
LEFT THE SCENE CLEARED <input type="checkbox"/> YES <input checked="" type="checkbox"/> NO <input type="checkbox"/> YES <input type="checkbox"/> NO	ACCIDENT CLASSIFICATION PROPERTY DAMAGE ONLY	NUMBER INURED	NUMBER KILLED	REPORT / CASE / INCIDENT NUMBER	
NUMBER OF VEHICLES INVOLVED	ACCIDENT DATE 01-13-2010	ACCIDENT TIME (MIL) 0738	TIME NOTIFIED (MIL) 0730	TIME ARRIVED (MIL) 0736	INVESTIGATION DATE 01-13-2010
2 - LOCATION COUNTY MUNICIPALITY		BEAT / ZONE	TRP / DIST / PCT	INVESTIGATED AT SCENE <input checked="" type="checkbox"/> YES <input type="checkbox"/> NO	
COL.	DISTANCE FROM	LOCATION	INVESTIGATED STREET OR HIGHWAY		
	100 FEET	<input type="checkbox"/> AFTER			
	SPEED LIMIT	<input checked="" type="checkbox"/> BEFORE	SPEED LIMIT	GEO. CODE	GPS LONGITUDE
	25	<input type="checkbox"/> AT	25		
PROPERTY DAMAGE BY: <input type="checkbox"/> 1. STATE <input type="checkbox"/> 2. COUNTY <input checked="" type="checkbox"/> 3. MUNICIPAL <input type="checkbox"/> 4. PRIVATE PROPERTY <input type="checkbox"/> 5. OTHER		LATITUDE			
GIVE OWNER'S NAME AND ADDRESS, DESCRIPTION OF PROPERTY, AND DAMAGE. <input type="checkbox"/> M/DOT					
J. PETERSON MO					
STRUCTURAL DAMAGE TO HOUSE FRONT (SOUTH EAST CORNER) DAMAGE UNDISAPPEARED					
4 - DRIVER 1 DRIVER LICENSE NUMBER / ID NUMBER		STATE	TYPE OF LICENSE	MC ENDORSEMENT	
		MO	<input checked="" type="checkbox"/> 1. OPERATOR CLASS E <input type="checkbox"/> 2. CDL CLASS	<input type="checkbox"/> 3. PERMIT <input type="checkbox"/> 4. UNLICENSED	<input type="checkbox"/> 5. MC ONLY <input type="checkbox"/> YES <input type="checkbox"/> NO <input checked="" type="checkbox"/> NA
PROOF OF INSURANCE <input checked="" type="checkbox"/> YES <input type="checkbox"/> NO <input type="checkbox"/> NOT REQUIRED		INSURANCE COMPANY FARMERS		POLICY NUMBER 1418395553	
YEAR	MAKE	MODEL	COLOR		
2002	HONDA	TRIBUTE	GRAY		
LIC. PLATE NO.	STATE	YEAR	VIN	TOTAL NO. OF OCCUPANTS	
	MO	2010	4F2YU08192K	1	
VEHICLE OWNER NAME (LAST, FIRST, MI) / COMMERCIAL CARRIER		ADDRESS (STREET, CITY, STATE, ZIP)			
		J. PETERSON MO			
VEHICLE DAMAGE (Circle all damaged areas)		TOWED FROM SCENE		TOW CO. INFORMATION	
<input type="checkbox"/> NONE		<input checked="" type="checkbox"/> YES <input type="checkbox"/> NO		A-Care Towing	
INITIAL IMPACT NO. 7		230 SPRING DR. ST. PETERS MO			
1. DRIVER 2 DRIVER LICENSE NUMBER / ID NUMBER		STATE	TYPE OF LICENSE	MC ENDORSEMENT	
			<input type="checkbox"/> 1. OPERATOR CLASS <input type="checkbox"/> 2. CDL CLASS	<input type="checkbox"/> 3. PERMIT <input type="checkbox"/> 4. UNLICENSED	<input type="checkbox"/> 5. MC ONLY <input type="checkbox"/> YES <input type="checkbox"/> NO <input type="checkbox"/> NA
PROOF OF INSURANCE <input type="checkbox"/> YES <input type="checkbox"/> NO <input type="checkbox"/> NOT REQUIRED		INSURANCE COMPANY		POLICY NUMBER	
				NA	
YEAR	MAKE	MODEL	COLOR		
N/A					
LIC. PLATE NO.	STATE	YEAR	VIN	TOTAL NO. OF OCCUPANTS	
VEHICLE OWNER NAME (LAST, FIRST, MI) / COMMERCIAL CARRIER		ADDRESS (STREET, CITY, STATE, ZIP)			
VEHICLE DAMAGE (Circle all damaged areas)		TOWED FROM SCENE		TOW CO. INFORMATION	
<input type="checkbox"/> NONE		<input type="checkbox"/> YES <input type="checkbox"/> NO			
INITIAL IMPACT NO. NA					
4 - WITNESS <input type="checkbox"/> NONE IDENTIFIED		NAME OF WITNESS		ADDRESS (STREET, CITY, STATE, ZIP)	
		J. PETERSON MO			
				TELEPHONE NO.	

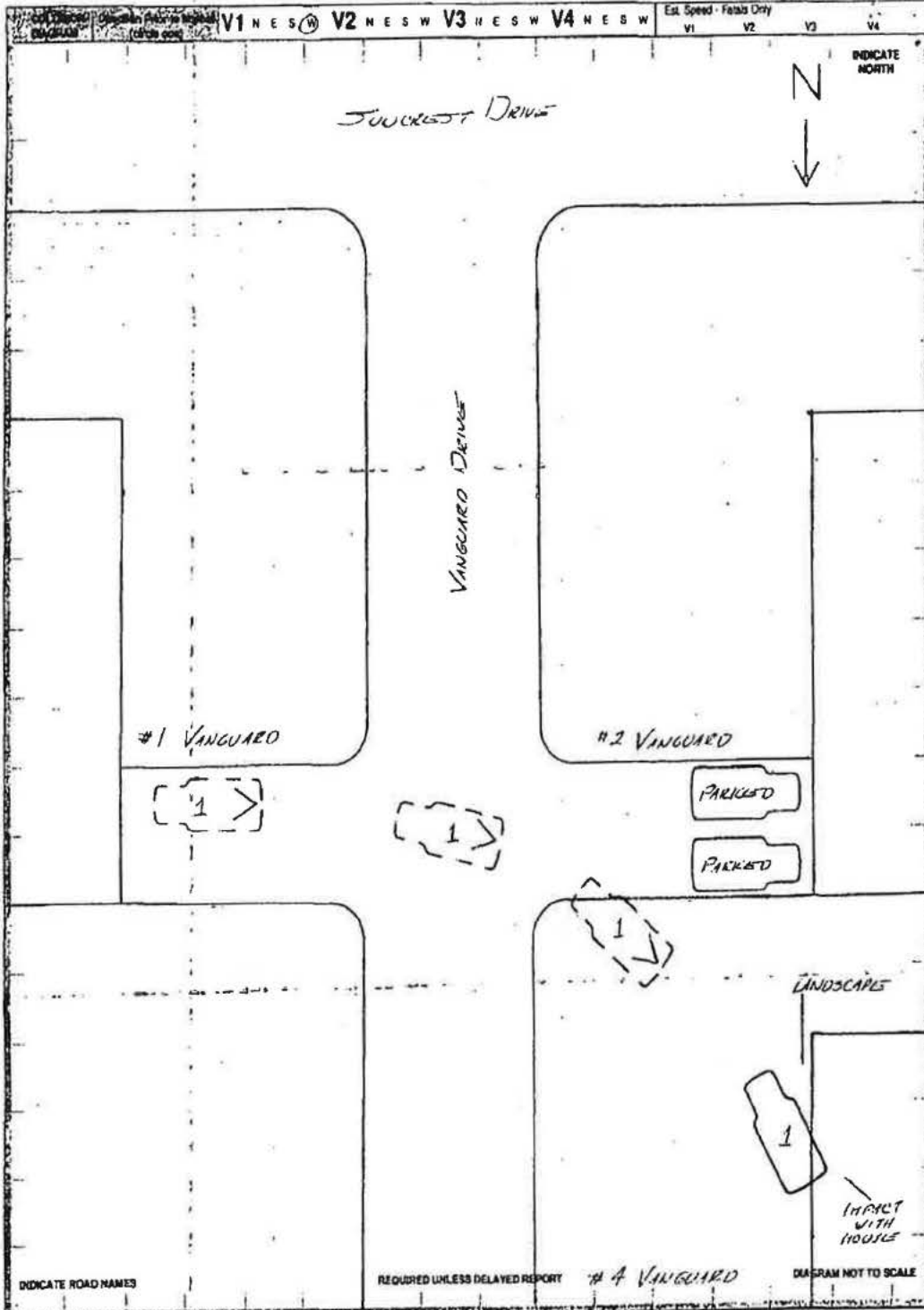

DEDICATE ROAD NAMES

REQUIRED UNLESS DELAYED REPORT

#4 VANGUARD

DIAGRAM NOT TO SCALE

8. EVIDENTIARY PHOTOS TAKEN

YES NO BY WHOM

AVAILABLE FROM

RECONSTRUCTION - Includes Narrative, Diagram, & Photo(s)

YES NO BY WHOM

9 - CODES

SEAT LOCATION IX - Not Known P - Pedestrian B - Bicycle M - Motorcycle OE - Occupant - Enclosed Load Area OU - Occupant - Unenclosed Load Area CP - Commercial Passenger SV - Other (Explain in Remarks)	<table border="1"> <tr><td>FR</td><td>SF</td><td>TR</td></tr> <tr><td>FC</td><td>SC</td><td>TC</td></tr> <tr><td>FL</td><td>SL</td><td>TL</td></tr> </table>	FR	SF	TR	FC	SC	TC	FL	SL	TL	INJURY 1. Fatal 2. Disabling 3. Evident - Not Disabling 4. Probable - Not Apparent 5. None Apparent 6. Unknown	TRANSPORTED (Medical Treatment) 1. No 2. EMS 3. Other 4. Unknown	EJECTION 1. NA 2. No 3. Partially 4. Totally 5. Unknown	AIR BAG FRONT 1. None / NA 2. Deployed 3. Not Deployed	AIR BAG SIDE 1. None / NA 2. Deployed 3. Not Deployed	SAFETY DEVICES 1. None 2. Not Used 3. Shoulder Belt Only 4. Lap Belt Only 5. Shoulder and Lap Belt 6. Child Restraint 7. Helmet Used 8. Helmet Not Used 9. Use Unknown
		FR	SF	TR												
FC	SC	TC														
FL	SL	TL														

10 - DRIVERS

NAME	DATE OF BIRTH	SEX	VEH NO.	SEAT LOC.	PL.	TRANS-PORT	EJEC-TION	AIR BAG	SAF DEV	TELEPHONE NO.
ADDRESS	MM-DD-YYYY							F S		
<input type="checkbox"/> NA DRIVER 1 - SAME ADDRESS AS ABOVE										
<input checked="" type="checkbox"/> NA DRIVER 2 - SAME ADDRESS AS ABOVE			2							

11 - OTHER OCCUPANTS & PEDESTRIANS (SAD = SAME AS DRIVER)

<input type="checkbox"/> SAD										
<input type="checkbox"/> SAD										
<input type="checkbox"/> SAD										
<input type="checkbox"/> SAD										
<input type="checkbox"/> SAD										
<input type="checkbox"/> SAD										

12. VEHICLE BODY TYPES

V1 V2 - NA

<input type="checkbox"/> 1. Passenger Car	<input type="checkbox"/> 2 Wh.
<input type="checkbox"/> 2. Station Wagon	<input type="checkbox"/> 3 Wh.
<input checked="" type="checkbox"/> 3. Sport Utility Vehicle	<input type="checkbox"/> 4 Wh.
<input type="checkbox"/> 4. Limousine (5-15 for hire)	<input type="checkbox"/> 5 Wh. or more
<input type="checkbox"/> 5. Van (8 or less with driver)	<input type="checkbox"/> Unknown
<input type="checkbox"/> 6. Small Bus (9-15 with driver)	
<input type="checkbox"/> 7. Bus (16 or more with driver)	
<input type="checkbox"/> 8. School Bus (less than 16 with driver)	
<input type="checkbox"/> 9. School Bus (16 or more with driver)	
<input type="checkbox"/> 10. Motorcycle	
<input type="checkbox"/> 11. ATV	
<input type="checkbox"/> 12. Motorized Bicycle	
<input type="checkbox"/> 13. Pedalcycle	
<input type="checkbox"/> 14. Motor Home / Camper	
<input type="checkbox"/> 15. Farm Implements	
<input type="checkbox"/> 16. Construction Equipment	
<input type="checkbox"/> 17. Other Transport Device	
<input type="checkbox"/> 18. Unknown	
<input type="checkbox"/> 19. Pick-up	
<input type="checkbox"/> 20. Single-unit Truck: 2 axles, 6 tires	
<input type="checkbox"/> 21. Single-unit Truck: 3 or more axles	
<input type="checkbox"/> A. Vehicle Pulling Another Unit(s) 1-21 only	
<input type="checkbox"/> 22. Truck Tractor With No Units	
<input type="checkbox"/> 23. Truck Tractor With One Unit	
<input type="checkbox"/> 24. Truck Tractor With Two Units	
<input type="checkbox"/> 25. Truck Tractor With Three Units	
<input type="checkbox"/> 26. Other Heavy Truck	

GCYW Rating (not licensed weights) 19-26 only
 Less than or equal to 10,000 lbs.
 10,001 - 26,000 lbs.
 Greater than 26,000 lbs.

13. EMERGENCY VEHICLE INVOLVEMENT

V1 V2 NA

<input type="checkbox"/> 1. Police
<input type="checkbox"/> 2. Fire
<input type="checkbox"/> 3. Ambulance
<input type="checkbox"/> 4. Other (must check 'A')

A. Emergency Vehicle on Emergency Run

14. HAZARDOUS MATERIALS NA

V1 V2

<input type="checkbox"/> Hazard Displayed
<input type="checkbox"/> 1. Gases in Bulk
<input type="checkbox"/> 2. Solids in Bulk
<input type="checkbox"/> 3. Liquids in Bulk
<input type="checkbox"/> 4. Explosives
<input type="checkbox"/> 5. None
<input type="checkbox"/> A. Hazardous Materials' Cargo Released / Spilled

15. ACCIDENT TYPE

1. On Roadway
 2. Off Roadway

COLLISION INVOLVING

<input type="checkbox"/> 1. Animal
<input type="checkbox"/> 2. Pedalcycle
<input checked="" type="checkbox"/> 3. Fixed Object
<input type="checkbox"/> 4. Other Object
<input type="checkbox"/> 5. Pedestrian
<input type="checkbox"/> 6. Train
<input type="checkbox"/> 7. MV in Transport
<input type="checkbox"/> 8. MV on Other Roadway
<input type="checkbox"/> 9. Parked MV

NON-COLLISION

<input type="checkbox"/> 10. Overtaking
<input type="checkbox"/> 11. Other Non-Collision

TWO VEHICLE COLLISION

<input type="checkbox"/> 60. Head On
<input type="checkbox"/> 61. Rear End
<input type="checkbox"/> 62. Sideswipe - Meeting
<input type="checkbox"/> 63. Sideswipe - Passing
<input type="checkbox"/> 64. Angle
<input type="checkbox"/> 65. Backed Into
<input type="checkbox"/> 67. Other

17. VEHICLE ACTION / SOURCE OF FRONTS

1. Going Straight	20. Ran Off Road - Right
2. Overtaking	21. Ran Off Road - Left
3. Making Right Turn	22. Overtum / Rollover
4. Right Turn on Red	23. Fire / Explosion
5. Making Left Turn	24. Immersion
6. Making U Turn	25. Jackknife
7. Sliding / Skidding	26. Cargo Loss / Shift
8. Stopping / Stopping	27. Equipment Failure
9. Start in Traffic	28. Separation of Units
10. Start From Parked	29. Returned to Road
11. Backing	30. Collision Inv. Pedestrian
12. Stopped in Traffic	31. Collision Inv. Pedalcycle
13. Parked	32. Collision Inv. Train
14. Changing Lanes	33. Collision Inv. Animal (enter code - explain)
15. Avoiding	34. Collision Inv. MV in Transport
16. Crossover Median	35. Collision Inv. Parked Motor Vehicle
17. Crossover Centerline	36. Collision Inv. Fixed Object (enter code - explain)
18. Crossing Road	37. Collision Inv. Other Object (explain)
19. Airborne	38. Other - Non Collision

V1 Unknown
10, 11, 19, 20, 36, 1

33. Animal Code _____
 36. Fixed Object Code 44, 36, 1

V2 Unknown
NA

33. Animal Code _____
 36. Fixed Object Code _____

18. TRAFFIC CONDITIONS

V1 V2 - NA

<input type="checkbox"/> 1. Normal
<input type="checkbox"/> 2. Accident Ahead
<input type="checkbox"/> 3. Congestion Ahead

Animal, Fixed Object, and Inattention Codes explained in narrative.

18. PEDESTRIAN INVOLVEMENT P1 P2 <input type="checkbox"/> NA <input type="checkbox"/> 1. At Intersection <input type="checkbox"/> 2. Not At Intersection CROSSING ROAD <input type="checkbox"/> 3. With Signal <input type="checkbox"/> 4. Against Signal <input type="checkbox"/> 5. No Signal <input type="checkbox"/> 6. Diagonally <input type="checkbox"/> 7. Within Crosswalk <input type="checkbox"/> 8. Within Marked Crosswalk <input type="checkbox"/> 9. Behind / In Front of Parked Car <input type="checkbox"/> 10. With Traffic <input type="checkbox"/> 11. Against Traffic <input type="checkbox"/> 12. Getting On / Off Vehicle <input type="checkbox"/> 13. Standing / Lying / Sitting on Road <input type="checkbox"/> 14. Pushing / Working on Vehicle <input type="checkbox"/> 15. Other Working <input type="checkbox"/> 16. Playing on Road <input type="checkbox"/> 17. Off Roadway 26. ROAD SURFACE <input type="checkbox"/> 1. Concrete <input type="checkbox"/> 3. Brick <input type="checkbox"/> 5. Dirt / Sand <input checked="" type="checkbox"/> 2. Asphalt <input type="checkbox"/> 4. Gravel <input type="checkbox"/> 6. Multi-Surface	19. VISION OBSCURED V1 V2 -N/A <input type="checkbox"/> 1. Windshield <input type="checkbox"/> 2. Load on Vehicle <input type="checkbox"/> 3. Trees / Brush <input type="checkbox"/> 4. Building <input type="checkbox"/> 5. Embankment <input type="checkbox"/> 6. Signboards <input type="checkbox"/> 7. Hillcrest <input type="checkbox"/> 8. Parked Cars <input type="checkbox"/> 9. Moving Cars <input type="checkbox"/> 10. Glare <input type="checkbox"/> 11. Other (explain) <input checked="" type="checkbox"/> 12. Not Obscured 24. WEATHER CONDITION <input type="checkbox"/> 1. Clear <input checked="" type="checkbox"/> 2. Cloudy <input type="checkbox"/> 3. Rain <input type="checkbox"/> 4. Snow <input type="checkbox"/> 5. Sleet <input type="checkbox"/> 6. Freezing (farp.) <input type="checkbox"/> 7. Fog / Mist <input type="checkbox"/> 8. Indeterminate (explain)	21. TRAFFIC CONTROL V1 V2 -N/A <input type="checkbox"/> 1. Construction Zone <input type="checkbox"/> 2. Other Work Zone <input type="checkbox"/> 3. School Zone <input type="checkbox"/> 4. Stop Sign <input type="checkbox"/> 5. Electric Signal <input type="checkbox"/> 6. RR Signal / Gate <input type="checkbox"/> 7. Yield Sign <input type="checkbox"/> 8. Officer / Flagman <input type="checkbox"/> 9. No Passing Zone <input type="checkbox"/> 10. Turn Restricted <input type="checkbox"/> 11. Signal on School Bus <input checked="" type="checkbox"/> 12. None	22. ROAD CHARACTER ALIGNMENT <input type="checkbox"/> 1. Straight <input type="checkbox"/> 2. Curve PROFILE <input checked="" type="checkbox"/> 1. Level <input type="checkbox"/> 2. Grade <input type="checkbox"/> 3. Hillcrest
	27 - COMMERCIAL MOTOR VEHICLE (Complete for each commercial vehicle involved.) Prepare the following to determine if this section should be completed: 1. Does this accident involve any of the following: 1. a person fatally injured; or 2. a person transported for medical attention; or 3. a vehicle towed from the scene of the accident <input type="checkbox"/> NO - DO NOT COMPLETE <input checked="" type="checkbox"/> YES - GO TO NUMBER 2 2. Examine each vehicle to determine if it is a commercial vehicle based on the following: 1. a truck with GVWR of more than 10,000 lbs. and engaged in commerce; or 2. a bus or school bus (9 or more including driver); or 3. a vehicle with a hazardous materials placard <input type="checkbox"/> NO - DO NOT COMPLETE <input type="checkbox"/> YES - COMPLETE SECTIONS B - E	B. CARRIER ID NUMBER V1 ICC NO. MC _____ USDOT NO. _____ V2 ICC NO. MC _____ USDOT NO. _____ C. HAZARDOUS MATERIAL PLACARD NUMBER <input type="checkbox"/> NA V1 4-Digit Placard Number from Diamond / Box _____ Number From Bottom of Diamond _____ V2 4-Digit Placard Number from Diamond / Box _____ Number From Bottom of Diamond _____ D. TRAFFICWAY <input type="checkbox"/> 1. Two-Way; Not Divided <input type="checkbox"/> 2. Two-Way; Divided; Unprotected Median <input type="checkbox"/> 3. Two-Way; Divided; Protective Median Barrier <input type="checkbox"/> 4. One-Way; Not Divided	E. CARGO BODY TYPE V1 V2 <input type="checkbox"/> 1. Enclosed Box <input type="checkbox"/> 2. Cargo Tank <input type="checkbox"/> 3. Flatbed <input type="checkbox"/> 4. Dump <input type="checkbox"/> 5. Concrete Mixer <input type="checkbox"/> 6. Auto Transporter <input type="checkbox"/> 7. Garbage / Refuse <input type="checkbox"/> 8. Grain, Chp. Gravel <input type="checkbox"/> 9. Pole Trailer <input type="checkbox"/> 10. Other

28 - NARRATIVE / STATEMENTS (If additional room is necessary, attach a separate sheet.)

1 DRIVER # 1 STATED THAT AS SHE BEGAN BACKING OUT OF HER DRIVELWAY THE VEHICLE BEGAN ACCELERATING DUE TO A MECHANICAL PROBLEM. DRIVER # 1 STATED SHE WAS UNABLE TO STOP AND CONTROL WAS LOST. VEHICLE # 1 TRAVELED OUT OF THE DRIVELWAY, ACROSS THE BRADWAY AND OVER THE DRIVELWAY AND YARD AT # 2 VANGUARD. VEHICLE # 1 CONTINUED IN A NORTHWESTERLY DIRECTION CROSSING THE LAWN AND IMPACTING THE LANDSCAPING AND HOUSE AT # 4 VANGUARD DRIVE.

THERE WAS SIGNIFICANT DAMAGE TO THIS PROPERTY AT # 4 VANGUARD. BUT NO INJURIES WERE REPORTED.

RESIDENT AT # 4 VANGUARD AT THE TIME OF THE INCIDENT WERE JONNA G. KRASSER 6-05-97, BRODIE DIERNEY 10-06, KAYLEE BEHRLE 7-01, AND CHEYANNE BEHRLE 2-01.

[REDACTED]	[REDACTED]	[REDACTED]	[REDACTED]
[REDACTED]	[REDACTED]	[REDACTED]	[REDACTED]
[REDACTED]	[REDACTED]	[REDACTED]	[REDACTED]
[REDACTED]	[REDACTED]	[REDACTED]	[REDACTED]

ST. PETERS POLICE DEPARTMENT Incident Narrative Report

LD #1

Print Date: January 14, 2010

Printed By: mhelm

Narratives for Incident Number [redacted] ? Yes

Other Narratives not authorized for print? None

Narratives this user authorized to print:

Narrative by: Patrolman Michael Helm

Date & Time	Narrative Description	Entered by	Status	Reviewed by	Last Edit Date
01/13/2010 08:46	ST. PETERS POLICE DEPARTMENT CRIME SCENE INVESTIGATION REPORT	Patrolman Michael Helm	Open		01/13/2010

REPORT NUMBER: [redacted]

DATE: 01-13-10

TIME: 0758

LOCATION: 4 Vanguard Dr.

TYPE OF INCIDENT: Vehicle Crash

VICTIM INFORMATION:
(If more than one victim repeat below information for each victim)

VICTIM NAME:
VICTIM ADDRESS:
VICTIM PHONE NUMBER(S):

REQUESTING OFFICER: Coulter

PROCESSING OFFICER: Helm

CRIME SCENE PROCESSED: Photographs only

LAB ID REQUEST:
(If NO, Do Not Complete EVIDENCE DISPOSITION)

EVIDENCE DISPOSITION:
DESTROY AFTER PROCESSING -
MAINTAIN AS EVIDENCE -
RELEASE TO OWNER -
(If RELEASE is requested, owner's name and phone number must be included below)
OWNER'S NAME:
PHONE NUMBER:

SCENE PROCESSING REPORT
(COMPLETED BY ID OFFICER)

TIME ON JOB: 30 minutes

TYPE AND DESCRIPTION OF SCENE: Vehicle crashed into house

MULTIPLE SCENES PROCESSED:
If YES, describe other scenes:

FINGERPRINT SEARCH: No
NUMBER OF LATENT CARDS: 0
CRIME SCENE SKETCH: Accident diagram by reporting officer

CRIME SCENE PHOTO / IMAGE AND EVIDENCE LOG
(Photo # and/or Evidence # followed by description)

TOTAL NUMBER OF PHOTOS: 37

ST. PETERS POLICE DEPARTMENT**Incident Narrative Report**

Print Date: January 14, 2010

Printed By: mhelm

Narratives for Incident Number 2010000000924 ? YesOther Narratives not authorized for print? None

Narratives this user authorized to print:

Narrative by: Patrolman Michael Helm

<u>Date & Time</u>	<u>Narrative Description</u>	<u>Entered by</u>	<u>Status</u>	<u>Reviewed by</u>	<u>Last Edit Date</u>
01/13/2010 08:46		Patrolman Michael Helm	Open		01/13/2010

P1 Overall scene 1 Vanguard
 P2 Overall scene roadway
 P3 Overall scene 4 Vanguard
 P4 Front of 1 Vanguard:
 P5 Driveway of 1 Vanguard
 P6 Roadway and driveway of 1 Vanguard
 P7 Roadway and front of 4 Vanguard
 P8 Vehicle in 4 Vanguard
 P9-P15 Various angles of vehicle in house

P16 VIN

P17-P25 Inside of residence

P26 Front of residence after vehicle moved
 P27 Same
 P28 Passenger side of vehicle
 P29 Passenger side of vehicle
 P30 Rear of vehicle
 P31 Front of residence
 P32 Same
 P33 Same
 P34 Inside of residence
 P35 Inside of residence
 P36 Inside of residence
 P37 Placard

PROCEDURE:

- 1) PROCESS SCENE
- 2) COMPLETE ID REPORT
- 3) SUBMIT LATENTS, REPORT AND EVIDENCE FOR PROCESSING
- 4) DROP KEY IN CRIME LAB SLOT

NOTE - DO NOT PUT LATENT EVIDENCE IN SAME LOCKER AS OTHER EVIDENCE. USE SEPARATE EVIDENCE SHEET WHEN SUBMITTING ITEMS TO BE PROCESSED.

CHECK LIST:

CRIME SCENE INVESTIGATION REPORT -
 AFIS ENVELOPE (IF APPLICABLE) -
 PROPERTY RECORD (IF LATENT EVIDENCE SEIZED) -
 CRIME SCENE SKETCH (IF APPLICABLE) -

CRIME LAB USE ONLY

EVIDENCE PROCESSED: YES / NO

REPORT COMPLETED: YES / NO

CRIME REPORT LOGGED: YES

ORIGINAL TO RECORDS: YES

LOGGED BY: *JCH/570*

ST. PETERS POLICE DEPARTMENT

Incident Narrative Report

Print Date: January 14, 2010

Printed By: mhelm

Narratives for Incident Number 2010000000924 ? Yes

Other Narratives not authorized for print? None

Narratives this user authorized to print:

Signature - Reporting Officer

Sgt. [Signature] 301

Signature - Reviewing Officer

PE12-019

MADZA

9/6/2012

APPENDIX 3 SUBJECT
VEHICLES

Lawsuit



TO: Robert Mercer
MAZDA MOTOR OF AMERICA, INC.
7755 Irvine Center Dr.
Irvine, CA, 92618-2922

RE: Process Served in Virginia

FOR: MAZDA MOTOR OF AMERICA, INC. (Domestic State: CA)

RECEIVED
OCT 21 2005
LEGAL DIVISION

ENCLOSED ARE COPIES OF LEGAL PROCESS RECEIVED BY THE STATUTORY AGENT OF THE ABOVE COMPANY AS FOLLOWS:

TITLE OF ACTION: [REDACTED] Pltf. vs. Mazda Motor of America, Inc., Dft.

DOCUMENT(S) SERVED: Notice of, Motion for Judgment

COURT/AGENCY: Staunton City Circuit Court, Va
Case # [REDACTED]

NATURE OF ACTION: Product Liability Litigation - Breach of Warranty - \$29,170.49

ON WHOM PROCESS WAS SERVED: C T Corporation System, Glen Allen, VA

DATE AND HOUR OF SERVICE: By Process Server on 10/20/2005 at 08:30

APPEARANCE OR ANSWER DUE: Within 21 Days

ATTORNEY(S) / SENDER(S): David W. Schmidt, Esq.
James B. Feinman & Associates
PO Box 697
Lynchburg, VA, 24505
434-846-7603

ACTION ITEMS: SOP Papers with Transmittal, via Fed Ex 2 Day, 791244209766
Email Notification, Jill Hortinela jhortine@mazdausa.com

SIGNED: C T Corporation System
PER: Nanette Rider
ADDRESS: 4701 Cox Road
Suite 301
Glen Allen, VA, 23060
TELEPHONE: 804-217-7255



Staunton Circuit Court
Law Division
113 E. Beverley Street
Staunton, VA 24401
540-332-3874

Notice Of Motion For Judgment

To: MAZDA MOTOR OF AMERICA INC
CT CORPORATION SYSTEM
REGISTERED AGENT
4701 COX ROAD
SUITE 301
GLEN ALLEN, VA

Case number: 7 [REDACTED]

You are hereby notified that unless, within twenty-one (21) days after the service of this notice of Motion for Judgment on you, response is made by filing in the clerk's office of this court a pleading in writing, in proper legal form, judgment may be entered against you by default.

Done in the name of the Commonwealth of Virginia on October 14, 2005.

Clerk of Court: Thomas E. Roberts

By:

(Clerk/Deputy Clerk)

Instructions:

Attorney's name: SCHMIDT, DAVID

- d. The vehicle has a faulty fuel gauge;
- e. The vehicle's engine revs-up for no apparent reason;
- f. The vehicle's paint is peeling off the front roof;
- g. The vehicle's engine cuts off for no reason.

3. These non-conformities to the applicable warranties are significant impairments that have been subject to repair three (3) or more times by the manufacturer, its agents or its authorized dealer(s) and the same non-conformities continue to exist. The vehicle has been returned for repair but to no avail. The vehicle has been out of service due to repair attempts over a cumulative total of 30 days.

4. These non-conformities to the applicable warranty are serious safety defects that have been subject to repair one or more times by the manufacturer, its agents or its authorized dealer and the same non-conformities continue to exist.

5. All attempts to repair these significant impairments have occurred within eighteen (18) months of the purchase of said vehicle. Under Virginia Code §59.1-207.13(B), it is presumed that the manufacturer has not conformed the aforesaid motor vehicle to the applicable warranty which is required by the Motor Vehicle Warranty Enforcement Act.

6. The plaintiff, [REDACTED] [REDACTED] has allowed the manufacturer, its agents or authorized dealers, full and ample opportunity to correct and repair the significant impairments and/or serious safety defects to the use of the vehicle, to the market value of the vehicle, and warranty defects in a good faith effort to resolve this dispute; however, the significant impairments and defects to the market value, and the warranty defects, have not been corrected as of this date.

7. The aforesaid defects, and the significant impairments to the market value of the vehicle and the breaches of warranty and the unsatisfactory attempts to repair the same constitute breaches of implied and expressed warranties on the part of the defendant, Mazda Motor of America, Inc., and the plaintiff, [REDACTED] [REDACTED] pray for relief available under the Commercial Code of Virginia, Virginia Code §8.2 et seq.

8. Pursuant to Virginia Code §59.1-207.9 et seq. the defendant, Mazda Motor of America, Inc., has been notified of the continuing non-conformities prior to the plaintiff, [REDACTED] [REDACTED] availing himself of this action.

WHEREFORE, the plaintiff, [REDACTED] [REDACTED] respectfully prays that this Court enter Judgment in his favor for Twenty-Nine Thousand One Hundred Seventy Dollars and Forty-Nine Cents (\$29,170.49) plus all finance charges associated with the loan, collateral charges, incidental damages, less a reasonable allowance for the use of the vehicle up to the date of the first notice of the non-conformity that was given to the manufacturer, its agents or authorized dealer, and for such other and further relief as the facts and equity as this case may require plus reasonable attorney's fees in the amount of \$300.00 per hour, expert witness fees and court costs.

Respectfully submitted,

[REDACTED] [REDACTED]

By: 
Of Counsel

David W. Schmidt, Esq.
James B. Feinman & Associates
P.O. Box 697
Lynchburg, Virginia 24505
Tel.: (434) 846-7603
Fax: (434) 846-0158

PE12-019

MADZA

9/6/2012

APPENDIX 3 SUBJECT
VEHICLES

Lawsuit



RECEIVED

MAR 01 2006

LEGAL

LAW OFFICES
DAVID J. GORBERG & ASSOCIATES, P.C.

1234 MARKET STREET

SUITE 2040

PHILADELPHIA, PA 19107-3789

1 (800) MY-LEMON

1 (800) 695-3666

(215) 563-7210

FAX (215) 563-8738

www.MyLemon.com

NEW JERSEY OFFICE

GREENTREE COMMONS

8001 D LINCOLN DRIVE WEST

MARLTON, NJ 08053-3211

(856) 797-0703

FAX (856) 983-6123

PITTSBURGH OFFICE

1301 GRANT BLDG.

310 GRANT STREET

PITTSBURGH, PA 15219

(412) 894-7004

FAX (412) 894-7006

DAVID J. GORBERG
DOMINIQUE GRENIER*
DANA LYNN TARQUINI*
TAMMY J. SCHMITT
MELISSA A. WEIK-HANNA*
TRACY A. PHILLIPS
KIMBERLY A. HOEHING*

OF COUNSEL
MEROVITZ AND CEDAR, LLP

*MEMBER OF PA AND NJ BARS

February 24, 2006

Mazda Motor of America, Inc. d/b/a
Mazda North American Operations
7755 Irvine Center Drive
Box 19734
Irvine, CA 92713

RE: [REDACTED] vs. Mazda
CCP February Term, 2006 No. 2395

Dear Sir/Madam:

Pursuant to the current Rules of Civil Procedure, we enclose herein the copy of the Civil Action Complaint, the original of which has been filed by our office in connection with the above referenced matter.

You are hereby notified that you have been sued in Court and that you must take action within twenty (20) days from your receipt of this letter or a default judgment may be entered against you.

Very truly yours,

DAVID J. GORBERG

DJG/as
Enclosure

CERTIFIED MAIL - RETURN RECEIPT REQUESTED

RECEIPT NO.: [REDACTED]

Civil Cover Sheet

002395

FEBRUARY 2006

PLAINTIFF'S NAME [REDACTED] DEFENDANT'S NAME MAZDA MOTOR OF AMERICA, INC d/b/a MAZDA NORTH AMERICAN OPERATIONS

PLAINTIFF'S ADDRESS Wynnewood, PA [REDACTED] DEFENDANT'S ADDRESS 7755 Irvine Center Drive Box 19734 Irvine, CA 92713

PLAINTIFF'S NAME [REDACTED] DEFENDANT'S NAME

PLAINTIFF'S ADDRESS [REDACTED] DEFENDANT'S ADDRESS

PLAINTIFF'S NAME [REDACTED] DEFENDANT'S NAME

PLAINTIFF'S ADDRESS [REDACTED] DEFENDANT'S ADDRESS

TOTAL NUMBER OF PLAINTIFFS TOTAL NO. OF DEFENDANTS COMMENCEMENT OF ACTION Complaint Petition Action Notice of Appeal Writ of Summons Transfer From Other Jurisdictions

AMOUNT IN CONTROVERSY \$50,000.00 or less More than \$50,000.00 COURT PROGRAMS Arbitration Jury Non-Jury Other Mass Tort Savings Action Petition Commerce Minor Court Appeal Statutory Appeals Settlement Minors W/D/Survival

CASE TYPE AND CODE (SEE INSTRUCTIONS) 1C Contract

STATUTORY BASIS FOR CAUSE OF ACTION (SEE INSTRUCTIONS) N/A

RELATED PENDING CASES (LIST BY CASE CAPTION AND DOCKET NUMBER) None IS CASE SUBJECT TO COORDINATION ORDER? Yes No

TO THE PROTHONOTARY:
Kindly enter my appearance on behalf of Plaintiff/Petitioner/Appellant:
Papers may be served at the address set forth below.

NAME OF PLAINTIFF/PETITIONER'S/APPELLANT'S ATTORNEY David J. Gorberg ADDRESS (SEE INSTRUCTIONS) 1234 Market Street Suite 2040 Philadelphia, PA 19107 PHONE NUMBER (215) 563-7210 FAX NUMBER (215) 563-8738

SUPREME COURT IDENTIFICATION NO 53084 E-MAIL ADDRESS

SIGNATURE [Signature] DATE 2/9/06

THIS IS ~~NOT~~ ARBITRATION

ASSESSMENT OF DAMAGES IS ~~NOT~~ REQUIRED

USTED ESTA ORDENADO COMPARCER EN ARBITRATION HEARING 1000 JPK DAVID STAFF PHILADELPHIA PA 19103
TIME: 9:30
OCT 19 2006
YOU MUST STILL COMPLY WITH THE NOTICE BELOW
USTED TODAVIA DEBE CUMPLIR CON EL AVISO PARA DEFENDERSE

DAVID J. GORBERG & ASSOCIATES, P.C.
BY: DAVID J. GORBERG
IDENTIFICATION NO: [REDACTED]
SUITE 2040
1234 MARKET STREET
PHILADELPHIA, PENNSYLVANIA 19107
(215) 563-7210

ATTORNEY FOR

plaintiffs

[REDACTED]
Wynnewood, PA [REDACTED]

COURT OF COMMON PLEAS
DIVISION

FEBRUARY 2006

TERM,

vs.

MAZDA MOTOR OF AMERICA, INC. d/b/a
MAZDA NORTH AMERICAN OPERATIONS
7755 Irvine Center Drive
Box 19734
Irvine, CA 92713

No.

[REDACTED]

THIS MATTER WILL BE HEARD BY A JUDGE ON AND AT THE TIME, DATE AND PLACE OF HEARING FOR ONE OR MORE PARTIES TO BE PRESENT AT THE HEARING. THE MATTER MAY BE HEARD AT THE SAME TIME AND DATE BEFORE A JUDGE OF THE COURT WITHOUT THE ABSENT PARTY OR PARTIES. THERE IS NO RIGHT TO A TRIAL DE NOVO ON APPEAL FROM A DECISION ENTERED BY A JUDGE.

ATTEST
FEB 23 2006
D. SAVAGE

NOTICE

You have been sued in court. If you wish to defend against the claims set forth in the following pages, you must take action within twenty (20) days after this complaint and notice are served, by entering a written appearance personally or by attorney and filing in writing with the court your defenses or objections to the claims set forth against you. You are warned that if you fail to do so the case may proceed without you and a judgment may be entered against you by the court without further notice for any money claimed in the complaint or for any other claim or relief requested by the plaintiff. You may lose money or property or other rights important to you.

YOU SHOULD TAKE THIS PAPER TO YOUR LAWYER AT ONCE. IF YOU DO NOT HAVE A LAWYER GO TO OR TELEPHONE THE OFFICE SET FORTH BELOW. THIS OFFICE CAN PROVIDE YOU WITH INFORMATION ABOUT HIRING A LAWYER. IF YOU CANNOT AFFORD TO HIRE A LAWYER, THIS OFFICE MAY BE ABLE TO PROVIDE YOU WITH INFORMATION ABOUT AGENCIES THAT MAY OFFER LEGAL SERVICES TO ELIGIBLE PERSONS AT A REDUCED FEE OR NO FEE.

LAWYER REFERENCE SERVICE
One Reading Center
1101 Market Street
Philadelphia, Pennsylvania 19107
(215) 238-6333

AVISO

Le han demandado en corte. Si usted deseen defender contra las demandas dispuestas en las páginas siguientes, usted debe tomar la acción en el plazo de veinte (20) días después de esta queja y se sirve aviso, incorporando un aspecto escrito personalmente o y archivando en escribir con la corte sus defensas u objeciones a las demandas dispuestas contra usted el abogado le advierte que si usted no puede hacer así que el caso puede proceder sin usted y un juicio se puede incorporar contra usted compra la corte sin aviso adicional para cualquier dinero demandado en la queja o para cualquier otro demanda o relovación pedida por el demandante. Usted puede perder el dinero o la característica de otra endereza importante a usted.

USTED DEBE LLEVAR ESTE PAPEL SU ABOGADO INMEDIATAMENTE. SI USTED NO HACE QUE UN ABOGADO VAYA A O LLAME POR TELÉFONO LA OFICINA DISPUESTA ABAJO. ESTA OFICINA PUEDE PROVEER DE USTED LA INFORMACIÓN SOBRE EMPLEAR A UN ABOGADO. SI USTED NO PUEDE PERMITIRSE AL HIRE A UN ABOGADO, ESTA OFICINA PUEDE PODER PROVEER DE USTED LA INFORMACIÓN SOBRE LAS AGENCIAS QUE LOS SERVICIOS JURIDICOS DE LA OFERTA DE MAYO A LAS PERSONAS ELEGIBLES EN UN HONORARIO REDUCIDO O NINGUN HONORARIO.

SERVICIO DE REFERENCIA LEGAL
One Reading Center
1101 Market Street
Philadelphia, Pennsylvania 19107
Teléfono: (215) 238-6333

DAVID J. GORBERG & ASSOCIATES, P.C.

By: **DAVID J. GORBERG**

Attorney for Plaintiffs

Identification No. [REDACTED]

1234 Market Street

Suite 2040

Philadelphia, PA 19107

(215) 563-7210

[REDACTED]

: COURT OF COMMON PLEAS

:

Wynnewood, PA [REDACTED]

: PHILADELPHIA COUNTY

:

vs.

: TERM, 2006

:

MAZDA MOTOR OF AMERICA, INC. d/b/a

:

MAZDA NORTH AMERICAN OPERATIONS

:

7755 Irvine Center Drive

:

Box 19734

:

Irvine, CA 92713

: NO.

COMPLAINT

1. Plaintiff, [REDACTED] is an adult individual citizen and legal resident of the Commonwealth of Pennsylvania, residing at [REDACTED], Wynnewood, PA [REDACTED]

2. Defendant, Mazda Motor of America, Inc. d/b/a Mazda North American Operations, is a business corporation qualified to do business and regularly conducts business in the Commonwealth of Pennsylvania with it's legal residence and principal place of business at 7755 Irvine Center Drive, Box 19734, Irvine, CA 92713.

BACKGROUND

3. Plaintiff incorporates by reference paragraphs 1 and 2 as fully as if set forth here length.

4. On or about July 8, 2004, Plaintiff purchased a 2004 Mazda Tribute manufactured and warranted by Defendant bearing the Vehicle Identification Number 4F2CZ04144K [REDACTED]. The vehicle was purchased and registered in the Commonwealth of Pennsylvania.

5. The price of the vehicle, including registration charges, document fees, sales tax, but, excluding other collateral charges not specified, totaled more than \$29,118.20.

6. Plaintiff avers that as a result of the ineffective repair attempts made by Defendant through its authorized dealer, the vehicle cannot be utilized for the purposes intended by Plaintiff at the time of acquisition and as such, the vehicle is worthless.

7. In consideration of the purchase of the above vehicle, Defendant, issued to Plaintiff several warranties, fully outlined in the warranty booklet.

8. On or about July 8, 2004, Plaintiff took possession of the above mentioned vehicle and experienced nonconformities, which substantially impaired the use, value and/or safety of the vehicle.

9. Said nonconformities consisted of, but was not limited to, defective engine and defective brakes. Copies of repair receipts are attached hereto and marked as Exhibit "A".

10. The nonconformities violate the express written warranties issued to Plaintiff by Defendant.

11. Plaintiff avers the vehicle has been subject to repair more than three (3) times for the same nonconformity, and the nonconformity remains uncorrected.

12. Plaintiff has delivered the nonconforming vehicle to an authorized service and repair facility of the defendant on numerous occasions. After a reasonable number of attempts, Defendant was unable to repair the nonconformities.

13. In addition, the above vehicle has or will in the future be out of service by reason of the non-conformities complained of for a cumulative total of thirty (30) days or more.

14. The vehicle continues to exhibit defects and nonconformities which substantially impair its use, value and/or safety.

15. Plaintiff avers the vehicle has been subject to additional repair attempts for defects and/or nonconformities and/or conditions for which the Defendant and or its authorized service center, may not have maintained records.

16. Plaintiff has been and will continue to be financially damaged due to Defendant's intentional, reckless, wanton and negligent failure to comply with the provisions of its' warranty.

17. Plaintiff seeks relief for losses due to the nonconformities and defects in the above mentioned vehicle in addition to attorney fees and all court costs.

COUNT I
PENNSYLVANIA AUTOMOBILE LEMON LAW CLAIM

18. Plaintiff hereby incorporates all facts and allegations set forth in this Complaint by reference as if fully set forth at length herein.

19. Plaintiff is a "Purchaser" as defined by 73 P.S. §1952.

20. Defendant is a "Manufacturer" as defined by 73 P.S. §1952.

21. Plaintiff's vehicle is a "New Motor Vehicle" as defined by 73 P.S. §1952.

22. Said vehicle experienced non conformities within the first year of purchase, which substantially impairs the use, value and safety of said vehicle.

23. Defendant failed to correct and or repair said nonconformities.

24. The vehicle continues to exhibit defects and nonconformities which substantially impair it's use, value and/or safety.

25. Defendant does not require participation in any informal dispute settlement program prior to filing suit.

26. As a direct and proximate result of Defendant's failure to repair the nonconformities , Plaintiff has suffered damages and, in accordance with 73 P.S. §1958, Plaintiff is entitled to bring suit for such damages and other legal and equitable relief.

27. Plaintiff avers that upon successfully prevailing upon the Lemon Law claim herein, all attorney fees are recoverable and are demanded against the Defendant.

WHEREFORE, Plaintiff respectfully demands judgment in his favor and against the Defendant in an amount equal to three (3) times the purchase price of the subject vehicle, plus all available collateral charges and attorney fees. Amount not in excess of \$50,000.00.

COUNT II
MAGNUSON-MOSS FEDERAL TRADE COMMISSION IMPROVEMENT ACT

28. Plaintiff hereby incorporates all facts and allegations set forth in this Complaint by reference as if fully set forth at length herein.

29. Plaintiff is a "Consumer" as defined by 15 U.S.C. §2301(3).

30. Defendant is a "Warrantor" as defined by 15 U.S.C. §2301(5).

31. Plaintiff uses the subject product for personal, family and household purposes.

32. By the terms of the express written warranties referred to in this Complaint, Defendant agreed to perform effective warranty repairs at no charge for parts and/or labor.

33. Defendant failed to make effective repairs.

34. As a direct and proximate result of Defendant's failure to comply with the express written warranties, Plaintiff has suffered damages and, in accordance with 15 U.S.C. §2310(d) (1), Plaintiff is entitled to bring suit for such damages and other legal and equitable relief.

35. Section 15 U.S.C. §2310 (d) (1) provides:

If a consumer finally prevails on an action brought under paragraph (1) of this subsection, he may be allowed by the Court to recover as part of the judgment a sum equal to the amount of aggregate amount of costs and expenses (including attorney fees based upon actual time expended), determined by the Court to have been reasonably incurred by the Plaintiff for, or in connection with the commencement and prosecution of such action, unless the Court, in its discretion shall determine that such an award of attorney's fees would be inappropriate.

36. Plaintiff avers that upon successfully prevailing upon the Magnuson-Moss claim herein, all attorney fees are recoverable and are demanded against the Defendant.

WHEREFORE, Plaintiff respectfully demands judgment in his favor and against the Defendant in an amount equal to three (3) times the purchase price of the subject vehicle, plus all available collateral charges and attorney fees. Amount not in excess of \$50,000.00.

COUNT III
UNIFORM COMMERCIAL CODE

37. Plaintiff hereby incorporates all the paragraphs of this Complaint by reference as if fully set forth at length herein.

38. The defects and nonconformities existing within the vehicle constitute a breach of contractual and statutory obligations of the Defendant, including but not limited to the following;

- a. Breach of Express Warranty
- b. Breach of Implied Warranty of Merchantability;
- c. Breach of Implied Warranty of Fitness For a Particular Purpose;

d. Breach of Duty of Good Faith.

39. The purpose for which Plaintiff purchased the vehicle include but are not limited to his personal, family and household use.

40. At the time of this purchase and at all times subsequent thereto, Plaintiff has justifiably relied upon Defendant's express warranties and implied warranties of fitness for a particular purpose and implied warranty of merchantability.

41. At the time of the purchase and at all times subsequent thereto, Defendant was aware Plaintiff was relying upon Defendant's express and implied warranties, obligations, and representations with regard to the subject vehicle.

42. Plaintiff has incurred damages as a direct and proximate result of the breach and failure of Defendant to honor its express and implied warranties.

43. Such damages include, but are not limited to, the purchase price of the vehicle plus all collateral charges, including attorney fees and costs, as well as other expenses, the full extent of which are not yet known.

WHEREFORE, Plaintiff respectfully demands judgment in his favor and against the Defendant in an amount equal to three (3) times the purchase price of the subject vehicle, plus all available collateral changes and attorney fees. Amount not in excess of \$50,000.00.

COUNT IV
PENNSYLVANIA UNFAIR TRADE PRACTICES AND
CONSUMER PROTECTION CLAIM

44. Plaintiff hereby incorporates all the paragraphs of this Complaint by reference as if set forth at length herein.

45. The Unfair Trade Practices and Consumer Protection Law defines unfair methods

of competition to include the following:

(xiv). Failing to comply with the terms of any written guarantee or warranty given to the buyer at, prior to, or after a contract for the purchase of goods or services is made.

46. Plaintiff, as a Pennsylvania resident, believes, and therefore, avers the reckless, wanton and willful failure of Defendant to comply with the terms of the written warranty constitutes an unfair method of competition.

47. Section 201-9.2(a) of the Unfair Trade Practices and Consumer Protection Law, authorizes the Court, in its discretion, to award up to three (3) times the actual damages sustained for violations of the Act.

WHEREFORE, Plaintiff respectfully demands judgment in his favor and against the Defendant in an amount equal to three (3) times the purchase price of the subject vehicle, plus all available collateral charges and attorney fees. Amount not in excess of \$50,000.00.

DAVID J. GORBERG & ASSOCIATES, P.C.

BY: 
DAVID J. GORBERG, ESQUIRE
Attorney for Plaintiff

VERIFICATION

I, **DAVID J. GORBERG**, verify that I am the attorney for the Plaintiff; and ~~that~~ the statements made in the attached Civil Action Complaint are based on information furnished to counsel, which information has been gathered by counsel in the course of this lawsuit; and that the language of this pleading is that of counsel. Signer verifies that he has read the within pleadings and that they are true and correct to the best of his knowledge, information and belief. This verification is made subject to the penalties of 18 Pa. C.S. 4904 relating to unsworn falsification to authorities.

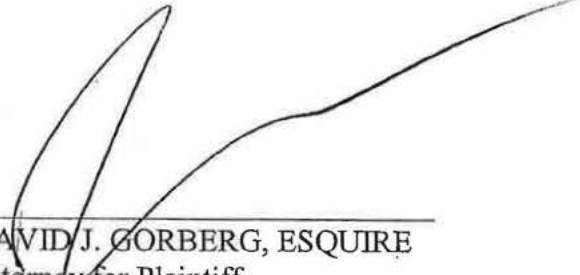

DAVID J. GORBERG, ESQUIRE
Attorney for Plaintiff

DATE: February 9, 2006

PE12-019

MADZA

9/6/2012

APPENDIX 3 SUBJECT
VEHICLES

Lawsuit



545928

CT CORPORATION
A WoltersKluwer Company

**Service of Process
Transmittal**

10/17/2007

CT Log Number [REDACTED]



TO: Chris Dzbanski
Ford Motor Company
Three Parklane Blvd., Ste.1400 West
Dearborn, MI 48126-

RE: Process Served in Michigan

FOR: Ford Motor Company (Domestic State: DE)

ENCLOSED ARE COPIES OF LEGAL PROCESS RECEIVED BY THE STATUTORY AGENT OF THE ABOVE COMPANY AS FOLLOWS:

TITLE OF ACTION: [REDACTED] Pltf. vs. Mazda Motor Company, et al. including Ford Motor Company, Dfts.

DOCUMENT(S) SERVED: Summons, Track Assignment Notice, Complaint, Information Statement

COURT/AGENCY: Superior Court - Law Division, Essex County, NJ
Case # [REDACTED]

NATURE OF ACTION: Product Liability Litigation - Manufacturing Defect - Brakes failed - Pertaining to a 2002 Mazda Tribute LX, VIN 4F2YU09112K [REDACTED] - Resulting in a vehicle collision on 12/22/2004

ON WHOM PROCESS WAS SERVED: The Corporation Company, Bingham Farms, MI

DATE AND HOUR OF SERVICE: By Process Server on 10/17/2007 at 16:16

APPEARANCE OR ANSWER DUE: Within 35 days from the date of receipt of Summons, not counting the date of receipt - File Answer // 300 Days, Starting From the First of the First Answer or 90 Days from Service on the First Defendant - Discovery

ATTORNEY(S) / SENDER(S): Robert F. DiStefano
Clark & DiStefano, P.C.
1500 Meeting House Road
Sea Girt, NJ 08750
732-528-9111

ACTION ITEMS: SOP Papers with Transmittal, via Fed Ex 2 Day , 798288906851
Image SOP - Page(s): 9
Email Notification, Chris Dzbanski CDZBANSK@FORD.COM

SIGNED:
PER:
ADDRESS: The Corporation Company
Stephanie Hendrickson
30600 Telegraph Road
Suite 2345
Bingham Farms, MI 48025-5720
TELEPHONE: 248-646-9033

LITIGATION
PRACTICE GROUP

7 OCT 18 P5:33

OFFICE OF THE
GENERAL COUNSEL

5010.2002
CLARK & DISTEFANO, P.C.
1500 MEETING HOUSE ROAD
SEA GIRT, NEW JERSEY 08750
(732) 528-9111
ATTORNEYS FOR PLAINTIFF, MARIA R. NARDONE

SUPERIOR COURT OF NEW JERSEY
LAW DIVISION: ESSEX COUNTY

PLAINTIFF(S)

DOCKET NO. [REDACTED]

-VS-

MAZDA MOTOR COMPANY, MAZDA NORTH
AMERICAN OPERATIONS, FORD MOTOR
COMPANY AND DOE CORPORATIONS
1 THROUGH 10, FICTITIOUS ENTITIES,

CIVIL ACTION

SUMMONS

DEFENDANT(S)

FORD MOTOR COMPANY, C/O RICHARD WOOD, ESQ., 3001 MILLER ROAD, DEARBORN, MI 48120;
ATTN: EMPLOYEE RELATIONS

From the State of New Jersey, To the Defendant{s} Named Above:

The plaintiff, named above, has filed a lawsuit against you in the Superior Court of New Jersey. The complaint attached to this summons states the basis for this lawsuit. If you dispute this complaint, you or your attorney must file a written answer or motion and proof of service with the deputy clerk of the Superior Court in the county listed above within {35} days from the date you received this summons, not counting the date you received it. {The address of each deputy clerk of the Superior Court is provided}. A \$135.00 filing fee payable to the Clerk of the Superior Court and completed Case Information Statement (available from the deputy clerk of the Superior Court) must accompany your answer or motion when it is filed. You must also send a copy of your answer or motion to plaintiff's attorney whose name and address appear above, or to plaintiff, if no attorney is named above. A telephone call will not protect your rights; you must file and serve a written answer or motion (with fee and completed Case Information Statement) if you want the court to hear your defense.

If you do not file and serve a written answer or motion within 35 days, the court may enter a judgment against you for the relief plaintiff demands, plus interest and costs of suit. If judgment is entered against you, the Sheriff may seize your money, wages or property to pay all or part of the judgment.

If you cannot afford to pay an attorney, you may call a Legal Services Office in the county where you live. A list of these offices is provided. If you do not have an attorney or are not eligible for free legal assistance, you may obtain a referral to an attorney by calling one of the Lawyer Referral Services. A list of these numbers is also provided.

Dated: 09/25/07

/s/Donald F. Phelan
DONALD F. PHELAN
Clerk of the Superior Court

ESSEX COUNTY - CIVIL DIVISION
SUPERIOR COURT OF NJ
465 MARTIN LUTHER KING JR BLVD
NEWARK NJ 07102

5010, 2002

TRACK ASSIGNMENT NOTICE

COURT TELEPHONE NO. (973) 693-6851
COURT HOURS

DATE: MARCH 20, 2007
RE: [REDACTED] ROONE US MAZDA MOTOR COMPANY
DOCKET: ESX [REDACTED]

THE ABOVE CASE HAS BEEN ASSIGNED TO: TRACK 2.

DISCOVERY IS 300 DAYS AND RUNS FROM THE FIRST ANSWER OR 90 DAYS FROM SERVICE ON THE FIRST DEFENDANT, WHICHEVER COMES FIRST.

THE PRETRIAL JUDGE ASSIGNED IS: HON GARRY J. FURNARI

IF YOU HAVE ANY QUESTIONS, CONTACT TEAM 003
AT: (973) 693-6443 EXT 6431.

IF YOU BELIEVE THAT THE TRACK IS INAPPROPRIATE YOU MUST FILE A CERTIFICATION OF GOOD CAUSE WITHIN 30 DAYS OF THE FILING OF YOUR PLEADING. PLAINTIFF MUST SERVE COPIES OF THIS FORM ON ALL OTHER PARTIES IN ACCORDANCE WITH R.4:5A-2.

ATTENTION:

ATT: ROBERT F. DISTEFANO
CLARK & DISTEFANO
1500 MEETING HOUSE ROAD
PO BOX 235
SEA GIRT NJ 08750

JUGHOOD

8

5010.2002 ✓
CLARK & DISTEFANO, P.C.
1500 MEETING HOUSE ROAD
SEA GIRT, NEW JERSEY 08750
(732) 528-9111
ATTORNEYS FOR PLAINTIFF, MARIA R. NARDONE

MAR 15 2007

SUPERIOR COURT OF NEW JERSEY
LAW DIVISION: ESSEX COUNTY

PLAINTIFF(S)

DOCKET NO. [REDACTED]

-VS-

MAZDA MOTOR COMPANY, MAZDA NORTH
AMERICAN OPERATIONS, FORD MOTOR
COMPANY AND DOE CORPORATIONS
1 THROUGH 10, FICTITIOUS ENTITIES,

CIVIL ACTION

COMPLAINT

DEFENDANT(S)

The plaintiff, [REDACTED] [REDACTED] residing at 49 Pulaski Street, in the Township of Bloomfield, County of Essex and State of New Jersey, by way of complaint against the defendants, says:

FIRST COUNT

1. At all times hereinafter mentioned, the plaintiff was the owner of a 2002 Mazda Tribute LX automobile which was manufactured in our about August 2001. This vehicle bore VIN number 4F2YU09112K [REDACTED].

2. At all relevant times hereto, Allstate Insurance Company, the real party in interest herein, provided a policy of automobile liability insurance on behalf of the plaintiff. The 2002 Mazda Tribute LX automobile was covered under the policy of automobile liability insurance issued by Allstate to the plaintiff.

3. At all relevant times hereto, the defendant, Mazda Motor Corporation, was a Japanese Corporation authorized and doing business in the State of New Jersey.

4. At all relevant times hereto, the defendant, Mazda North American Operations, was a California corporation authorized and doing business in the State of New Jersey.

5. At all relevant times hereto, the defendant, Ford Motor Company, was a Delaware Corporation authorized and doing business in the State of New Jersey.

6. At all relevant times hereto, the defendants, Doe Corporations 1 through 10, fictitious entities, were corporations and/or business entities unknown to the plaintiff who may have been responsible for the cause of action as set forth by the plaintiff herein.

7. On December 22, 2004, the plaintiff was operating her 2002 Mazda Tribute LX automobile in a southerly direction on Broughton Avenue in Bloomfield, New Jersey. The plaintiff struck a motor vehicle in the rear after the brakes on the plaintiff's 2002 Mazda Tribute LX automobile failed.

8. It was subsequently determined that the brakes on the plaintiff's 2002 Mazda Tribute LX automobile failed as a result of a product defect within said automobile.

9. The defendants were negligent in that they manufactured, designed, assembled, supplied, delivered, sold, installed, distributed and serviced a defective automobile or component thereof.

10. As a direct and proximate result of the negligence of the defendants as set forth above, the plaintiff's 2002 Mazda Tribute LX automobile sustained severe damage and the plaintiff was injured.

11. As a result of the negligence of the defendants as set forth above, the plaintiff submitted a claim to her insurance company, Allstate Insurance Company, the real party in interest herein, as a result of the plaintiff's automobile being severely damaged, requiring extensive repairs, was depreciated in value and the plaintiff lost the use thereof.

WHEREFORE, the plaintiff demands judgment against the defendants, jointly and severally, for damages together with interest, attorney's fees and costs of suit.

SECOND COUNT

1. The plaintiff repeats and realleges all of the allegations contained in the first count as if same were set forth at length herein.

2. At all times relevant hereto, the defendants, as part of their regular business, manufactured, designed, assembled, supplied, delivered, sold, distributed and/or serviced defective automobiles and/or parts thereof which were placed into the stream of commerce and became an intricate part of the automobile owned by the plaintiff. Said products were defective in that they were not safe nor reasonably fit for their intended purposes.

3. At all times relevant hereto, the above mentioned defective products were used and employed for the purposes for which they were manufactured, designed, assembled, supplied, delivered, installed, sold and/or serviced and were intended to be used in the manner foreseeable to the defendants.

4. As a direct and proximate result of the defective, dangerous and unsafe products being placed into the stream of commerce by the defendants, the plaintiff's vehicle sustained damage and the plaintiff was injured as a result thereof.

WHEREFORE, the plaintiff demands judgment against the defendants, jointly and severally, for damages together with interest, attorney's fees and costs of suit.

THIRD COUNT

1. The plaintiff repeats and realleges all of the allegations contained in the first and second count as if same were set forth at length herein.

2. The defendants expressly and impliedly warranted that the 2002 Mazda Tribute LX automobile which they manufactured, designed, assembled, supplied, delivered, sold, installed, distributed and/or serviced, was free of any defects and was reasonably fit for the purpose for which it was intended to be used.

3. The defendants breached said warranties in that the 2002 Mazda Tribute LX automobile which they manufactured, designed, assembled, supplied, delivered, sold, installed, distributed and/or serviced, was defective and unsafe.

4. As a direct and proximate result of the breach of warranties by the defendants, the plaintiff's 2002 Mazda Tribute LX automobile sustained severe damage and the plaintiff was injured.

WHEREFORE, the plaintiff demands judgment against the defendants, jointly and severally, for damages together with interest, attorney's fees and costs of suit.

TRIAL COUNSEL DESIGNATION

Pursuant to R. 4-5-1{c}, Robert F. DiStefano, Esquire, is hereby designated as trial counsel in this matter.

REQUEST FOR INTERROGATORIES

Pursuant to R. 4:17-1, et seq., demand is hereby made as to the defendant for answers to interrogatories within the time set forth in the Rules of Court.

CERTIFICATION OF OTHER ACTIONS

I hereby certify that the matter in controversy is not the subject of any other action or arbitration proceeding, now or contemplated, and that no other parties should be joined. R.4:5-1.

CLARK & DISTEFANO, P.C

Dated: 03/05/07

By: 
Robert F. DiStefano, Esquire



CIVIL CASE INFORMATION STATEMENT

(CIS)

Use for initial Law Division
Civil Part pleadings (not motions) under Rule 4:5-1
Pleading will be rejected for filing, under Rule 1:5-6(c),
if information above the black bar is not completed or
if attorney's signature is not affixed.

FOR USE BY CLERK'S OFFICE ONLY

PAYMENT TYPE: CK CG CA

CHG/CK NO.

AMOUNT:

OVERPAYMENT:

BATCH NUMBER:

1. ATTORNEY/PRO SE NAME

Robert F. DiStefano

2. TELEPHONE NUMBER

(732) 528-9111

3. COUNTY OF VENUE

Essex

4. FIRM NAME (if applicable)

Clark & DiStefano

5. DOCKET NUMBER (when available)

[REDACTED]

6. OFFICE ADDRESS

1500 Meetinghouse Rd.
Sea Girt, NJ 08750

7. DOCUMENT TYPE

Complaint

8. JURY DEMAND

YES NO

9. NAME OF PARTY (e.g., John Doe, Plaintiff)

[REDACTED]

10. CAPTION

[REDACTED]

Mazda Motor Co., et al

11. CASE TYPE NUMBER
(See reverse for listing)

[REDACTED]

12. IS THIS A PROFESSIONAL MALPRACTICE CASE? YES NO

IF YOU HAVE CHECKED "YES," SEE N.J.S.A. 2A:53A-27 AND APPLICABLE CASE LAW REGARDING YOUR OBLIGATION TO FILE AN AFFIDAVIT OF MERIT.

13. RELATED CASES PENDING?

YES NO

14. IF YES, LIST DOCKET NUMBERS

15. DO YOU ANTICIPATE ADDING ANY PARTIES (arising out of same transaction or occurrence)? YES NO

16. NAME OF DEFENDANT'S PRIMARY INSURANCE COMPANY, IF KNOWN

NONE
 UNKNOWN

THE INFORMATION PROVIDED ON THIS FORM CANNOT BE INTRODUCED INTO EVIDENCE.

CASE CHARACTERISTICS FOR PURPOSES OF DETERMINING IF CASE IS APPROPRIATE FOR MEDIATION

17. A. DO PARTIES HAVE A CURRENT, PAST OR RECURRENT RELATIONSHIP? YES NO

IF YES, IS THAT RELATIONSHIP EMPLOYER-EMPLOYEE FRIEND/NEIGHBOR OTHER (explain)
 FAMILIAL BUSINESS

18. B. DOES THE STATUTE GOVERNING THIS CASE PROVIDE FOR PAYMENT OF FEES BY THE LOSING PARTY? YES NO

19. USE THIS SPACE TO ALERT THE COURT TO ANY SPECIAL CASE CHARACTERISTICS THAT MAY WARRANT INDIVIDUAL MANAGEMENT OR ACCELERATED DISPOSITION:

20. DO YOU OR YOUR CLIENT NEED ANY DISABILITY ACCOMMODATIONS? YES NO

IF YES, PLEASE IDENTIFY THE REQUESTED ACCOMMODATION:

21. WILL AN INTERPRETER BE NEEDED? YES NO

IF YES, FOR WHAT LANGUAGE:

22. ATTORNEY SIGNATURE

[Handwritten Signature]



CIVIL CASE INFORMATION STATEMENT (CIS)

Use for initial pleadings (not motions) under *Rule 4:5-1*

CASE TYPES (Choose one and enter number of case type in appropriate space on the reverse side.)

Track I — 150 days' discovery

- 151 NAME CHANGE
- 175 FORFEITURE
- 302 TENANCY
- 399 REAL PROPERTY (other than Tenancy, Contract, Condemnation, Complex Commercial or Construction)
- 502 BOOK ACCOUNT (debt collection matters only)
- 505 OTHER INSURANCE CLAIM (INCLUDING DECLARATORY JUDGMENT ACTIONS)
- 506 PIP COVERAGE
- 510 UM or UIM CLAIM
- 511 ACTION ON NEGOTIABLE INSTRUMENT
- 512 LEMON LAW
- 801 SUMMARY ACTION
- 802 OPEN PUBLIC RECORDS ACT (SUMMARY ACTION)
- 999 OTHER (Briefly describe nature of action)

Track II — 300 days' discovery

- 305 CONSTRUCTION
- 509 EMPLOYMENT (other than CEPA or LAD)
- 599 CONTRACT/COMMERCIAL TRANSACTION
- 603 AUTO NEGLIGENCE – PERSONAL INJURY
- 605 PERSONAL INJURY
- 610 AUTO NEGLIGENCE – PROPERTY DAMAGE
- 699 TORT – OTHER

Track III — 450 days' discovery

- 005 CIVIL RIGHTS
- 301 CONDEMNATION
- 602 ASSAULT AND BATTERY
- 604 MEDICAL MALPRACTICE
- 606 PRODUCT LIABILITY
- 607 PROFESSIONAL MALPRACTICE
- 608 TOXIC TORT
- 609 DEFAMATION
- 616 WHISTLEBLOWER / CONSCIENTIOUS EMPLOYEE PROTECTION ACT (CEPA) CASES
- 617 INVERSE CONDEMNATION
- 618 LAW AGAINST DISCRIMINATION (LAD) CASES

Track IV — Active Case Management by Individual Judge / 450 days' discovery

- 156 ENVIRONMENTAL/ENVIRONMENTAL COVERAGE LITIGATION
- 303 MT. LAUREL
- 508 COMPLEX COMMERCIAL
- 513 COMPLEX CONSTRUCTION
- 514 INSURANCE FRAUD
- 701 ACTIONS IN LIEU OF PREROGATIVE WRITS

Mass Tort (Track IV)

- | | |
|---|----------------------------------|
| 240 REDUX/PHEN-FEN (formerly "DIET DRUG") | 268 MANUFACTURED GAS PLANT (MGP) |
| 241 TOBACCO | 271 ACCUTANE |
| 248 CIBA GEIGY | 272 BEXTRA/CELEBREX |
| 264 PPA | 601 ASBESTOS |
| 266 HORMONE REPLACEMENT THERAPY (HRT) | 619 VIOXX |

If you believe this case requires a track other than that provided above, please indicate the reason on Side 1, in the space under "Case Characteristics."

Please check off each applicable category:

Verbal Threshold

Putative Class Action

Title 59

PE12-019

MADZA

9/6/2012

APPENDIX 3 SUBJECT
VEHICLES

Lawsuit



**Service of Process
Transmittal**

12/14/2007

CT Log Number [REDACTED]



TO: Shawn Murphy, VP & General Counsel of MNAO
Mazda North American Operations
7755 Irvine Center Drive
Irvine, CA 92618

RE: Process Served in Massachusetts

FOR: MAZDA MOTOR OF AMERICA, INC. (Domestic State: CA)

RECEIVED
DEC 17 2007
LEGAL DIVISION

ENCLOSED ARE COPIES OF LEGAL PROCESS RECEIVED BY THE STATUTORY AGENT OF THE ABOVE COMPANY AS FOLLOWS:

TITLE OF ACTION: Plymouth Rock Assurance Corporation as subrogee of Egor Racz, Plif. vs. Mazda Motor of America, Inc., Dft.

DOCUMENT(S) SERVED: Summons, Proof of Service Form, Complaint and Jury Demand, Cover Sheet

COURT/AGENCY: Boston Municipal Court Department of The Trial Court-Civil Business Central Division, Suffolk County, MA
Case # [REDACTED]

NATURE OF ACTION: Product Liability Litigation - Manufacturing Defect - Tribute vehicle's accelerator malfunctioned

ON WHOM PROCESS WAS SERVED: C T Corporation System, Boston, MA

DATE AND HOUR OF SERVICE: By Process Server on 12/14/2007 at 14:45

APPEARANCE OR ANSWER DUE: Within 20 days, exclusive of the day of service - File Answer // Within 5 days - File answer with the Clerk of Courts

ATTORNEY(S) / SENDER(S): Jorge A. Solis
Gibson & Behman, P.C.
One Faneuil Hall Marketplace
South Building, Fourth Floor
Boston, MA 02109
617-723-9170

ACTION ITEMS: SOP Papers with Transmittal, via Fed Ex 2 Day , 791456566851
Email Notification, Jill Hortinela jhortine@mazdausa.com

SIGNED: C T Corporation System
PER: Dahrlena Mitchell
ADDRESS: 155 Federal Street
Suite 700
Boston, MA 02110
TELEPHONE: 617-757-6404

Commonwealth of Massachusetts

SUFFOLK, SS.

BOSTON MUNICIPAL COURT DEPARTMENT
OF THE TRIAL COURT FOR CIVIL BUSINESS
CENTRAL DIVISION.
07 01 CV

CIVIL No.

006490 DE-7-07

Plymouth Rock Assurance Corp.
Plaintiff(s)

SUMMONS

Mazda Motor of America, Inc.
Defendant(s)

To the above-named defendant:

You are hereby summoned and required to serve upon Jorge A. Solis

plaintiff's attorney, whose address is 1 Faneuil Hall Market place, Suite Bld., Boston MA 0210
a copy of your answer to the complaint which is herewith served upon you, within twenty (20) days after service of this summons, exclusive of the day of service. You are also required to file your answer to the complaint in the Office of the Clerk/Magistrate of this Court either before service upon plaintiff's attorney, or within five (5) days thereafter. If you fail to meet the above requirements, judgment by default may be rendered against you for relief demanded in the complaint.

Unless otherwise provided by Rule 13(a), your answer must state as a counterclaim any claim which you may have against the plaintiff which arises out of the transaction or occurrence that is the subject matter of the plaintiff's claim or you will be barred from making such claim in any other action.

WITNESS, CHARLES R. JOHNSON, Esq. at Boston, the day of

....., in the year of our Lord two thousand and

John Carter Daniel J Hogan
17-14-07
CLERK / MAGISTRATE.

NOTES.

- (1) When more than one defendant is involved, the names of all defendants should appear in the caption. If a separate summons is used for each defendant, each should be addressed to the particular defendant.
- (2) The number assigned to the complaint by the Clerk/Magistrate's Office at commencement of the action shall be affixed to this summons before it is served.

NOTICE TO DEFENDANT - YOU NEED NOT APPEAR PERSONALLY IN COURT TO ANSWER THE COMPLAINT, BUT IF YOU CLAIM TO HAVE A DEFENSE, EITHER YOU OR YOUR ATTORNEY MUST SERVE A COPY OF YOUR WRITTEN ANSWER WITHIN TWENTY (20) DAYS AS SPECIFIED HEREIN AND ALSO FILE THE ORIGINAL IN THE CLERK/MAGISTRATE'S OFFICE.

PROOF OF SERVICE OF PROCESS

I hereby certify that on....., 2
I served a copy of the within summons, together with a copy of the complaint in this action, upon the within-named defendant, in the following manner (See Rule 4(d) (1-5):*

.....
.....
.....

Dated: 2

N.B. TO PROCESS SERVER:-
PLEASE PLACE DATE YOU MAKE SERVICE ON DEFENDANT IN THIS BOX AND ON COPY SERVED ON DEFENDANT AND RETURN ORIGINAL TO THIS COURT.

..... 2

* If service is made at the last and usual place of abode, the officer shall forthwith mail first class a copy of the summons to such last and usual place of abode, and shall set forth in the return the date of mailing and the address to which the summons was sent (G.L. Chap. 223 sec. 31).



The Commonwealth of Massachusetts

SUFFOLK, ss. BOSTON MUNICIPAL COURT DEPARTMENT
OF THE TRIAL COURT FOR CIVIL BUSINESS
CENTRAL DIVISION

No.

Plff(s)

v.

Defft(s)

SUMMONS

(Mass. R. Civ. P. 4)

OFFICE OF THE CLERK / MAGISTRATE
BOSTON MUNICIPAL COURT DEPARTMENT
CENTRAL DIVISION
24 NEW CHARDON STREET, SIXTH FLOOR
BOSTON, MASSACHUSETTS 02114

COMMONWEALTH OF MASSACHUSETTS

SUFFOLK, ss.

001400 DE-707

TRIAL COURT DEPARTMENT
BOSTON MUNICIPAL COURT
C. A. NO.:

07 01 CV

PLYMOUTH ROCK ASSURANCE)
CORPORATION AS SUBROGEE)
OF EGOR RACZ)
Plaintiff,)
)
v.)
)
MAZDA MOTOR of AMERICA, INC.,)
Defendant)

COMPLAINT AND JURY DEMAND

PARTIES

1. The Plaintiff, Plymouth Rock Assurance Corporation (“Plymouth Rock”), is a duly organized corporation under the laws of the Commonwealth of Massachusetts, with a principle place of business located at 695 Atlantic Avenue in Boston, MA 02111.
2. Plymouth Rock, is exercising its right to subrogation pursuant to an insurance contract that it has with Egor Racz.
3. The Defendant, Mazda Motor Corporation, is a corporation duly organized under the laws of the State of California with a principal place of business located at 7755 Irvine Center Drive, Irvine, CA 92623-9734, and which, directly, or by agent, transacts business within the Commonwealth of Massachusetts.

4. Jurisdiction is proper in the Court pursuant to M.G.L. ch. 223A §3, as a result of the Defendant, Mazda Motor Corporation conducting business within the Commonwealth of Massachusetts, and an incident arising out of said business transactions within this jurisdiction of the Commonwealth of Massachusetts.

FACTS

5. Prior to December 7, 2004, the Defendant, Mazda Motor Corporation, designed, manufactured, inspected, tested, assembled, sold, distributed and/or supplied a 2002 Mazda Tribute vehicle equipped with a 3.0 liter engine.
6. On or about December 7, 2004, the subject Tribute vehicle's accelerator malfunctioned, causing a collision with another vehicle.
7. In January of 2005, the Defendant, Mazda Motor Corporation, sent out a recall for 2002-2004 Tribute accelerator cables. The recall specified that the accelerator cable may prevent the throttle from returning to the idle position, which could result in vehicle crashes without warning.
8. Plymouth Rock paid five thousand five hundred and six dollars and fifty-four cents (\$5,506.54) for said property damage to Egon Racz's vehicle and one thousand four hundred and fifty five dollars and fifty-three cents (\$1,455.53) for damages to the vehicle that Egon Racz's Tribute vehicle collided with pursuant to its insurance policy with Egon Racz.

COUNT I - NEGLIGENCE

9. The Plaintiff repeats and fully incorporates by reference herein paragraphs 1 through 9 above.

10. As a direct and proximate result of the negligence of the Defendant, Mazda Motor Corporation, in the design, manufacture, inspection, testing, assembly, sale, distribution and/or supply of the subject accelerator cable for the Tribute model vehicle; and as a direct and proximate result of the negligence of the Defendant, Mazda Motor Corporation, Mr. Racz suffered extensive property damage to his vehicle. Plaintiff compensated Mr. Racz for said property damage as well as the owner of the vehicle Mr. Racz hit pursuant to an insurance contract it has with him.

WHEREFORE, the Plaintiff, Plymouth Rock, demands judgment against the Defendant, Mazda Motor Corporation in the amount of six thousand nine hundred and sixty two dollars and seven cents (\$6,962.07) together with interests therein, costs, attorney's fees and other relief this Honorable Court deems just and equitable.

COUNT II – BREACH OF WARRANTY

11. The Plaintiff repeats and fully incorporates by reference herein paragraphs 1 through 11 above.
12. Prior to December 7, 2004, the Defendant, Mazda Motor Corporation, in its sale, design, manufacture, distribution and supply of the subject Tribute vehicles made implied warranties of merchantability, safety and fitness for the ordinary purpose for which the subject product was to be used.
13. Said warranties were breached by the Defendant as the subject Tribute vehicle was not safe, not merchantable, not fit for the ordinary purpose for its intended use.

14. As a direct and proximate result of the Defendant, Mazda Motor Corporation's breach of warranties, the Egon Racz suffered extensive property damage as well as causing damage to another vehicle. Plaintiff compensated the Egon Racz for said property damage pursuant to an insurance contract.

WHEREFORE, the Plaintiff, Plymouth Rock, demands judgment against the Defendant, Mazda Motor Corporation in the amount of six thousand nine hundred and sixty two dollars and seven cents (\$6,962.07) together with interests therein. costs, attorney's fees and other relief this Honorable Court deems just and equitable.

COUNT III – UNFAIR COMPETITION PURSUANT TO M.G.L. c. 93A

15. The Plaintiff repeats and fully incorporates by reference herein paragraphs 1 through 15 above.
16. As a result of the Defendant, Mazda Motor Corporation's, material and substantial breach of warranties, the Defendant has committed unfair or deceptive acts or practices in its conduct of trade or commerce in violation of the Massachusetts Consumer Protection statute. M.G.L. c. 93A

WHEREFORE, the Plaintiff, Plymouth Rock, demands judgment against the Defendant, Mazda Motor Corporation in the amount of six thousand nine hundred and sixty two dollars and seven cents (\$6,962.07) together with interests therein. costs, attorney's fees, treble damages pursuant to M.G.L. c. 93A, and other relief this Honorable Court deems just and equitable.

PLAINTIFF DEMANDS A TRIAL BY JURY ON ALL COUNTS.

Dated: 12/7/07

Respectfully submitted
The Plaintiff,
by its attorney,

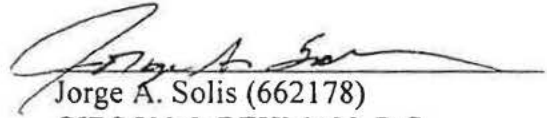

Jorge A. Solis (662178)
GIBSON & BEHMAN, P.C.
One Faneuil Hall Marketplace
South Building, fourth floor
Boston, MA 02109
(617) 723-9170

CIVIL ACTION COVER SHEET	DOCKET NO(S)	Trial Ct. of Massachusetts Superior Court Department County: <u>Suffolk - BMC</u>	
PLAINTIFF(S) <u>Plymouth Rock Assurance Corp.</u> <u>a/s/o Egor Racz</u>		DEFENDANT(S) <u>Mazda Motor Corp.</u>	
ATTORNEY, FIRM NAME, ADDRESS AND TELEPHONE <u>Gibson & Behman, P.C.</u> <u>Jorge Solis</u> <u>One Mountain Road, Burlington, MA</u> Board of Bar Overseers number: <u>01816</u>		ATTORNEY of known:	
Origin code and track designation			
Place an X in one box only:			
<input checked="" type="checkbox"/> 1. F01 Original Complaint	<input type="checkbox"/> 4. F04 District Court Appeal (C 231, s. 97 & 104 (After trial) (N))		
<input type="checkbox"/> 2. F02 Removal to Sup. Ct. (231, s. 104 (Before trial) (F))	<input type="checkbox"/> 5. F05 Reactivated after rescript, relief from judgment/Order (Mass.R.Civ.P. 60)(N)		
<input type="checkbox"/> 3. F03 Retransfer to Sup. Ct. (C 231, s. 102)(N)	<input type="checkbox"/> 6. E10 Summary process Appeal (N)		
TYPE OF ACTION AND TRACK DESIGNATION (See reverse side)			
CODE NO.	TYPE OF ACTION (Specify)	TRACK	IS THIS A JURY CASE?
<u>B06</u>	<u>product liability</u>	<u>(F)</u>	<u>(X)</u> Yes () No
The following is a full, itemized and detailed statement of the facts on which plaintiff relies to determine money damages. For this form, disregard double or treble damage claims; indicate single damages only.			
TORT CLAIMS (Attach additional sheets as necessary)			
A. Documented medical expenses to date:			
1. Total hospital expenses	\$
2. Total doctor expenses	\$
3. Total chiropractic expenses	\$
4. Total physical therapy expenses	\$
5. Total other expenses (describe)	\$
Subtotal			\$
B. Documented lost wages and compensation to date	\$
C. Documented property damages to date	\$	<u>6,962.07</u>
D. Reasonably anticipated future medical and hospital expenses	\$
E. Reasonably anticipated lost wages	\$
F. Other documented items of damages (describe)	\$
TOTAL			\$ <u>6,962.07</u>
CONTRACT CLAIMS (Attach additional sheets as necessary)			
Provide a detailed description of claim(s):			
TOTAL \$		
PLEASE IDENTIFY, BY CASE NUMBER AND COUNTY, ANY RELATED ACTION PENDING IN THE SUPERIOR COURT DEPARTMENT			
"I hereby certify that I have complied with the requirements of Rule 5 of the Supreme Judicial Court Uniform Rules on Dispute Resolution (SJC Rule 1:18) requiring that I provide my clients with information about court-connected dispute resolution services and discuss with them the advantages and disadvantages of the various methods."			
Signature of Attorney of Record <u>Jorge A. Solis</u>			Date: <u>12/7/07</u>