

INFORMATION Redacted PURSUANT TO THE FREEDOM OF
INFORMATION ACT (FOIA), 5 U.S.C . 552(B)(6)

EA12-001
CHRYSLER
10-4-2012
ENCLOSURE 4
FIELD DATA SUBJECT
CAIRs Backup



3052

CASE #
9027763

Jeep



CASE # 9027762



CASE #
9027763

ED SCHMIDT
Jeep

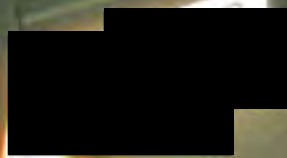



CASE #
9027763



CASE #
9027763

THIS PAPER
IS TO BE USED TO
MARK EVIDENCE
IN YOUR VEHICLE
FOR INVESTIGATION
PURPOSES. IT IS NOT
TO BE USED TO
MARK OTHER EVIDENCE
OR OTHER ITEMS
IN YOUR VEHICLE.



**CASE #
9027763**

3052

CASE #
9027763

A photograph showing the underside of a vehicle, likely a truck or heavy-duty car, with a focus on the suspension and tire area. A man is looking up at the vehicle. A sign is attached to the suspension, displaying a case number. The background shows a workshop or garage setting.

CASE #
9027763

A photograph showing the underside of a dark-colored car, specifically the rear suspension and a tire. A black tag with white text is attached to the suspension components. The tag reads "CASE # 9027763". A man in a grey shirt is looking up at the car's undercarriage. The background shows a workshop or garage setting with other vehicles and equipment.

CASE #
9027763

DAIMLERCHRYSLER REACQUIRED VEHICLE BUYBACK AND DISPOSAL SYSTEM

Approved Buyback Package -- 1/9/2002

STATUS: Check Request Approved

Disposal Package Open

CAIR 9027763 VIN 2W [REDACTED] Zone 42 Dealer 26571

Owner [REDACTED] VIN 1J4GL48K72V [REDACTED] I/S/D 6/30/2001
 Address [REDACTED]
TOLEDO, OH [REDACTED]

Phone [REDACTED] Year 02
 M/M JEEP LIBERTY SPORT 4X4 SPORT UTILITY 4-DR

CAIR 9027763 Amount \$21,679.13
 Payee #1 Ed Schmidt Jeep
 Address 26875 N Dixie Hwy
Perrysburg, OH 43552

Miles 2,140
 Warranty Expense \$53.73

Total \$21,679.13

Type Replacement Category N - Accident

State Lemon Law Filed? No State? _____
 DaimlerChrysler Arbitration Case Filed? No DC Case # _____
 Arbitration/LL/Litigation-Settled/Decision? _____ Date? _____
 FL Lemon Law Case # _____ RV? _____

Disposal Type _____

Title State _____ Title Number _____ Branding Required _____

Vehicle Location _____
 Address _____

Contact: _____ Phone: _____

Cannot Resell In: _____ Assign to Auction: _____

Were multiple repair attempts made for the same nonconformity? _____
 Were there repairs to Steering/Brakes/Safety Hazards? _____
 Was the vehicle reacquired due to days out of service? _____ No of Days _____
 Any Prior or Current Accident Damage? _____

Describe Area Repaired and the Approximate Cost of Repair _____

RC	NONCONFORMITY	Status Code	DATE REPAIRED or OTHER COMMENTS
1.			1.
2.			2.
3.			3.
4.			4.
5.			5.

Replacement Vehicle Worksheet

CAIR # 9027763

VIN # 1J4GL48K72W

Owner Name: MR.

New Vin 1J4GL48K42V

USAGE FEE

Mileage 0 X \$0.00 = \$0.00
(# of miles) (cost/mile)

AND/OR

Purchase \$0.00 X 0 Miles = \$0.00
 Price 100,000
(insert either 100,000 or 120,000)

AND/OR

Mileage Offset Calculation
(Purchase Price * Miles / (100,000 or 120,000)) * 50%

\$0.00 X 0
100,000
 = \$0.00 X 50% = \$0.00
(Usage Fee) (Offset)

AND/OR

Flat Usage Fee \$0.00

A. TOTAL USAGE FEE \$0.00

MSRP CALCULATION

MSRP (New Vin) \$23,000.00

AfterMarket Accessories / Conversion
(when added at customer expense)

\$0.00
\$0.00
\$0.00

1. Total MSRP Value (New Vin) \$23,000.00

MSRP (Old Vin) \$23,000.00

AfterMarket Accessories / Conversion
(only if items are not added to new Vin)

\$0.00
\$0.00
\$0.00

2. Total MSRP Value (Old Vin) \$23,000.00

B. MSRP DIFFERENCE (1 - 2) 0

C. OWNER CONTRIBUTION TO VEHICLE COST (A + B) \$0.00

REMARKS

Mileage fee waived, please refer to CAIR line 029.

Old Vin 1J4GL48K72W

OWNER'S COLLATERAL COSTS

Taxes \$0.00
 License & Title Fees \$0.00
 Doc Fees \$0.00
 Damage (Requires Estimate) \$0.00
 Service Contract \$0.00
 Other \$0.00

D. TOTAL COLLATERAL COSTS \$0.00

VEHICLE COST

New Vehicle Invoice Cost \$21,983.00
 Less Holdback \$672.00
 Subtotal \$21,311.00
 AfterMarket Accessories / Conversion
(items added to new vin only)

\$0.00
\$0.00
\$0.00
 Owner Contribution (Step C) (+/-) \$0.00

E. TOTAL VEHICLE COST \$21,311.00

COLLATERAL COSTS

Taxes \$3.13
 License & Title Fees \$15.00
 Doc Fees \$50.00
 Service Contract \$0.00
 Dealer Handling \$300.00
 Other \$0.00
 Owner Contribution (Step D) (+/-) \$0.00

F. TOTAL COLLATERAL COSTS \$368.13

TOTAL AMOUNT REQUESTED (E + F) \$21,679.13

OWNER CHECK TO DEALER (C + D) \$0.00

DAIMLERCHRYSLER REACQUIRED VEHICLE BUYBACK AND DISPOSAL SYSTEM

Approved Buyback Package -- 1/9/2002 (con't)

CAIR 9027763

VIN 2W

HISTORY

Approval History

Check Request

Approved -- 1/9/02 11:11:58 AM (Edward J Janke)
Submitted for Approval -- 01/09/2002 8:02:58 AM (Vanessa Kibble)
Submitted for Review -- 01/08/2002 4:15:24 PM (Marne Ellis)
1/9/02 2400038817 - Ed Schmidt Jeep \$21679.13

Original Selling Dealer Information

Dealer: 26571

ED SCHMIDT JEEP

26875 N DIXIE HWY

PERRYSBURG, OH 43552

Main Number: 8744331

DAIMLERCHRYSLER REACQUIRED VEHICLE BUYBACK AND DISPOSAL SYSTEM

Approved Disposal Package -- 01/22/2002

STATUS: Check Request Approved

Disposal Package Approved

CAIR 9027763 VIN 2W [REDACTED]

Zone 42

Dealer 26571

Owner [REDACTED]
Address [REDACTED]
TOLEDO, OH

VIN 1J4GL48K72W [REDACTED]

I/S/D 6/30/2001

Year 02

M/M JEEP LIBERTY SPORT 4X4 SPORT UTILITY 4-DR

Phone 419-944-5373

Miles 2,140

Warranty Expense \$53.73

CAIR 9027763 Amount \$21,679.13

Payee #1 Ed Schmidt Jeep

Address 26875 N Dixie Hwy
Perrysburg, OH 43552

Total \$21,679.13

Type Replacement

Category N - Accident

State Lemon Law Filed? No State? _____
DaimlerChrysler Arbitration Case Filed? No DC Case # _____
Arbitration/LL/Litigation-Settled/Decision? _____ Date? _____
FL Lemon Law Case # _____ RV? _____

Disposal Type Auction

Title State OH Title Number 31 0346 8408 Branding Required No

Vehicle Location DETROIT AUTO AUCTION
Address 20911 GLADWIN
TAYLOR, MI 48180
Contact: Debbie Holme Phone: 734-246-2293

Cannot Resell In: AL, MD, ND, VT, ID, MN, NH, OH, PA Assign to Auction: 553

Were multiple repair attempts made for the same nonconformity? Yes
Were there repairs to Steering/Brakes/Safety Hazards? Yes
Was the vehicle reacquired due to days out of service? No No of Days _____
Any Prior or Current Accident Damage? No

Describe Area Repaired and the Approximate Cost of Repair _____

RC	NONCONFORMITY	Status Code	DATE REPAIRED or OTHER COMMENTS
0123	1. While making a right turn both front airbags deployed.	A	1. 10/1/01-Replace airbag control module.
	2.		2.
	3.		3.
	4.		4.
	5.		5.

DAIMLERCHRYSLER REACQUIRED VEHICLE BUYBACK AND DISPOSAL SYSTEM
Approved Disposal Package -- 01/22/2002 (con't)

CAIR 9027763

VIN 2W

HISTORY

Approval History

Check Request

Approved -- 1/9/02 11:11:58 AM (Edward J Janke)
Submitted for Approval -- 01/09/2002 8:02:58 AM (Vanessa Kibble)
Submitted for Review -- 01/08/2002 4:15:24 PM (Marne Ellis)
1/9/02 2400038817 - Ed Schmidt Jeep \$21679.13

Disposal Package

Approved -- 1/22/02 9:11:27 AM (Vincent P Imperiale)
Submitted for Approval -- 01/18/2002 2:18:58 PM (John Monroe)
Submitted for Review -- 01/18/2002 12:43:05 PM (Darla Rollins)

Original Selling Dealer Information

Dealer: 26571

ED SCHMIDT JEEP

26875 N DIXIE HWY

PERRYSBURG, OH 43552

Main Number: 8744331

Consigned Auction Inforr

Auction: 553

DETROIT AUTO AUCTION

20911 GLADWIN

TAYLOR, MI 48180

Main Number: 734-246-2293

DATE 09/05/01 X210170T ACCTS RECEIVABLE VEHICLE INQUIRY TIME 12:13:37

VEHICLE FOUND ON VEHICLE DB

VIN - 1J4GL48K72W [REDACTED] PROD STATUS - KZ VON/TON - 61766521 AR TYPE - FIRM
BUILT DATE 060901 STATUS DATE 061201 INVOICE DATE 060801 SOLD DATE 070201
SOLD TO - 42 26571 INVOICE TO - 42 26571 SHIP TO - 26571 M0714 2607

DIVRSN/COLL INV#	CI DATE	CI CANCELL DATE
REVENUE		COST
BASE VEHICLE -	16,739.00	BASE VEHICLE - 0.00
OPTIONS -	4,039.00	OPTION COST - 0.00
GROUP FUNDS -	620.00	TIRE TAX - 0.00
DESTINATION -	585.00	DESTINATION - 0.00
TOTAL INVOICE -	21,983.00	HANDLING - 0.00
TOTAL MSRP -	23,000.00	PLT SPEC EQUIP- 0.00
		BODY VENDOR - 0.00
		TOTAL COST - 0.00

MEMO INFO :
HOLD BACK - 672.00-
EMPLOYEE NVP - 20,671.00

USE PF1 FOR PRINTED OUTPUT PF8 TO OBTAIN "HELP" INFORMATION
PF10 TO RETURN TO PRIOR MENU PF11 TO RETURN TO PRIMARY MENU

NEXT INQUIRY VIN OR VON/TON CARLINE YEAR

DAIMLERCHRYSLER MOTORS CORPORATION INVOICE

1664-A

PLANT	ZONE	DEALER	VEHICLE ID NO.	INVOICE NO.	INVOICE DT
TOLEDO NORTH	42	26571	1J4GL48K42W	2-KJJ-61766564	06/18/01

SHIP TO: ED SCHMIDT JEEP EAGLE
PO BOX 111
PERRYSBURG OH 43551

IGN KEY M1248
TRK KEY 1248
ACC KEY 3432
2462-01-6218

SOLD TO: ED SCHMIDT JEEP EAGLE
PO BOX 111
PERRYSBURG OH 43551

SHIPPING WT. 4135

PAID FOR BY: HUNTINGTON NATIONAL BANK
CREDIT SALE XX CASH SALE

SAE HP 32.2
000-044000-00

BODY & EQUIP.

DESCRIPTION

FACTORY WHOLESALE PRICE

MJH74	JEEP LIBERTY SPORT	16,944.00
PU2	Woodland Brown Satin Glow	
MSL5	Seats - Cloth High-Back Bucket	NO CHARGE
UG4	Transmission-Multi-Speed Auto, 45RFE	743.00
EKG	Engine - 3.7L Power Tech V6	765.00
CEG	Glass - Deep Tint Sunscreen	243.00
CTS	Mirrors - Power Heated, Fold-Away	45.00
LNJ	Fog Lamps	108.00
MHM	Speed Control	270.00
FBK	Radio-AM/FM Compact Disc w/Chgr Ctrl	113.00
TSN	Tires - P235/70R16 OWL All Terrain	221.00
YDH	DaimlerChrysler Owner Loyalty Mail	20.00
YGE	5 Additional Gallons Of Gas	8.00
2TB	Customer Preferred Package 2TB	
27B	Customer Preferred Package 27B	2,201.00
3VD	Customer Preferred Discount	698.00
E25	DETROIT OUTSTATE - DAA	205.00
L25	DETROIT OUTER - PPA/EB-PF	210.00
309	DESTINATION CHARGE	585.00
	HB 67200	

02.3182
3miles
06.27.01

JUN 27 2001

MDH # 061612
EP 20671

MSRP RETAIL TOTAL	23,000.00	TOTAL 21,983.00
		ORIGINAL INVOICE

HIS VEHICLE IS MANUFACTURED TO MEET SPECIFIC UNITED STATES REQUIREMENTS. THIS VEHICLE IS NOT MANUFACTURED FOR SALE OR REGISTRATION OUTSIDE OF THE UNITED STATES.

09/05/01

08:26

ED SCHMIDT AUTO GROUP -> 214-634-2263

SEP-4-01 12:53;

NO. 729 003

PAGE 2/2

VEHICLE ORDER



P.O. Box 111 • 25875 Dixie Hwy. Rte. 25 • (419) 874-4931
PERRYSBURG, OHIO 43652-0111
www.edschmidt.com

STOCK NO. (12-3154)

OTL. NO. 87923

JUN 30 1981

PURCHASER'S NAME DATE
STREET ADDRESS PHONE
CITY STATE OH ZIP SALESMAN'S NAME MICHAEL J FUJAWA

PLEASE ENTER MY ORDER FOR ONE NEW USED CAR TRUCK DEMONSTRATOR AS FOLLOWS:

Table with vehicle details: Year 2002, Make JEEP, Model LIBERTY, Body Type 4DR, Color BR SILVER, Trim DK FLATE 6. Includes VIN and Mileage/Odometer fields.

Table for 'ADDITIONAL EQUIPMENT' and 'CASH PRICE OF VEHICLE'.

Table for 'DEPOSIT RECEIPT' and 'NEGATIVE EQUITY'. Includes 'CASH PRICE OF VEHICLE HAS BEEN RAISED TO COVER NEGATIVE EQUITY IN TRADE-IN VEHICLE' and 'SELLING PRICE 22853.39'.

Table for 'TRADE-IN AND OTHER CREDITS'. Includes 'TRADE-IN ALLOWANCE', 'BALANCE OWED ON TRADE', 'NET EQUITY', 'DEPOSIT', 'CASH ON DELIVERY', 'OTHER', 'TOTAL CREDIT', 'TOTAL CREDIT', 'TRADE-IN STOCK NO.', 'YEAR', 'MAKE', 'MOO.', 'BODY TYPE', 'VIN', 'MILEAGE', 'BALANCE DUE'.

ALL WARRANTIES, IF ANY, BY A MANUFACTURER OR SUPPLIER OTHER THAN DEALER ARE THEIRS, NOT DEALER'S, AND ONLY SUCH MANUFACTURER OR OTHER SUPPLIER SHALL BE LIABLE FOR PERFORMANCE UNDER SUCH WARRANTIES. UNLESS DEALER FURNISHES BUYER WITH A SEPARATE WRITTEN WARRANTY OR SERVICE CONTRACT MADE BY DEALER ON ITS OWN BEHALF, DEALER HEREBY DISCLAIMS ALL WARRANTIES, EXPRESS OR IMPLIED, INCLUDING ANY IMPLIED WARRANTIES OF MERCHANTABILITY OF FITNESS FOR A PARTICULAR PURPOSE: (A) ON ALL GOODS AND SERVICES SOLD BY DEALER, AND (B) ON ALL USED VEHICLES WHICH ARE HEREBY SOLD "AS IS-NOT EXPRESSLY WARRANTED OR GUARANTEED."

IF THIS CONTRACT IS A FINANCE SALE ARRANGED BY ED SCHMIDT PONTIAC, GMC TRUCK, INC., THEN THIS ORDER IS NOT VALID UNTIL A FINANCE DISCLOSURE STATEMENT IS FILLED IN AND SIGNED BY THE BUYER.

THIS ORDER IS NOT VALID UNLESS SIGNED AND ACCEPTED BY DEALER OR HIS AUTHORIZED REPRESENTATIVE. ACCEPTED BY PURCHASER DATE 06/30/01. APPROVED DEALER OR AUTHORIZED REPRESENTATIVE SIGNATURE

FIRST CARE, THEN CARE™

ed schmidt

PONTIAC • GMC • JEEP • VOLVO • SAAB • VOLKSWAGEN

P.O. Box 111 • 26875 Dixie Hwy. Rte. 25 • (419) 874-4331
PERRYSBURG, OHIO 43552-0111

VEHICLE WORKSHEET

STOCK NO. 02-3182

CTL. NO. _____

PURCHASER'S NAME

9/5/01

STREET ADDRESS

PHONE _____

CITY TOLEDO

STATE OHIO

ZIP _____

SALESMAN'S NAME M. KUTALIA

PLEASE ENTER MY ORDER FOR ONE NEW USED CAR TRUCK DEMONSTRATOR AS FOLLOWS:

YEAR	MAKE	MODEL	BODY TYPE	COLOR	TRIM
<u>2002</u>	<u>JEOP</u>	<u>LIBERTY</u>	<u>SPORT 404w</u>	<u>WOODLAND BROWN</u>	<u>CLTB</u>
MVI OR SERIAL NO	<u>1J4GL4BK42W</u>		<u>927</u>	MILEAGE APPEARING ON ODOMETER	<input checked="" type="checkbox"/> ODOMETER MILEAGE IS ACCURATE <input type="checkbox"/> ODOMETER MILEAGE IS NOT ACCURATE

ADDITIONAL EQUIPMENT	CASH PRICE OF VEHICLE

SUB-TOTAL		
DEPOSIT RECEIPT:	NEGATIVE EQUITY:	
PURCHASE OPTION GOOD UNTIL _____ DEPOSIT IS NOT REFUNDABLE UNLESS BUYER IS UNABLE TO OBTAIN FINANCING. IF THIS DEPOSIT IS IN CONNECTION WITH THE SPECIAL ORDER OF A VEHICLE NOT IN OUR POSSESSION. IT IS NOT REFUNDABLE UNLESS VEHICLE IS UNDELIVERABLE OR DELIVERED AT A HIGHER PRICE THAN QUOTED.	CASH PRICE OF VEHICLE HAS BEEN RAISED TO COVER NEGATIVE EQUITY IN TRADE-IN VEHICLE. X	SELLING PRICE <u>23000 00</u>
		DOCUMENTARY FEE <u>50 00</u>
		SUB-TOTAL → <u>23050 00</u>

TRADE-IN ALLOWANCE	<u>23000 00</u>	→	TAXABLE TOTAL	<u>50 00</u>	X <u>6 1/4</u> % - SALES TAX	<u>3 13</u>
BALANCE OWED ON TRADE					COUNTY <u>LUCAS</u>	
BALANCE OWED TO:			CONTRACTUAL DISCLOSURE STATEMENT FOR USED VEHICLE ONLY The information you see on the window form for this vehicle is part of this contract. Information on the window form overrides any contrary provisions in the contract of sale.			LICENSE & TITLE <u>15 00</u>
NET EQUITY					OTHER	
DEPOSIT					TOTAL	<u>23068 13</u>
CASH ON DELIVERY					TOTAL CREDIT	<u>23000 00</u>
OTHER					BALANCE DUE	<u>68 13</u>
TOTAL CREDIT	<u>23000 00</u>	→				
TRADE-IN STOCK NO.	YEAR <u>2002</u> MAKE <u>Jeep</u> MOD <u>LIBERTY</u>					
	BODY TYPE <u>40R</u> VIN <u>1J4GL4BK72W</u>					

This Vehicle Worksheet is not a valid contract.
The vehicle order, signed by an authorized representative of the dealership,
is the valid contract.

ACCEPTED BY PURCHASER _____ DATE _____
SIGNED _____ PURCHASER _____

INCENTIVE RESOLUTION AGREEMENT

Dealer: Ed Schmidt Jeep
26875 N Dixie Hwy
Perrysburg, OH 43552
Dealer Code: 26571

In mutual resolution of the complaint of [REDACTED] regarding his/her vehicle, VIN:
1J4GL48K72W [REDACTED] we have agreed to place [REDACTED] into another vehicle, VIN:
1J4GL48K42W [REDACTED]

As part of this transaction, I understand and agree that the new vehicle, VIN:
1J4GL48K42W136337 will be ineligible and disqualified from all consumer and dealer incentive
programs available. Nor will it count as a "qualifying" unit toward any dealer objective for such incentives /
programs.

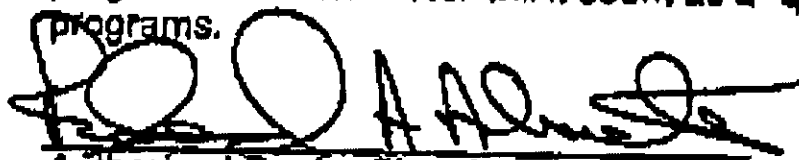
Authorized Dealer Signature
Sales Rep.
Title

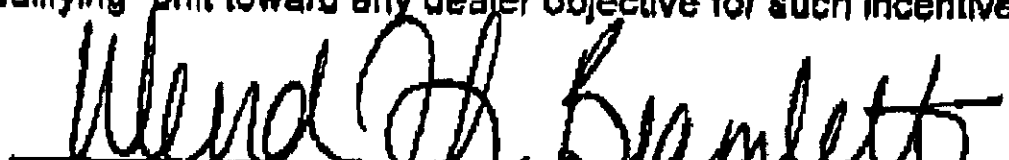
Authorized DaimlerChrysler Signature

Ed Schmidt Jeep
Dealership Name
26571
Dealer Code

ISG
Zone
91
Zone Code

DaimlerChrysler Corporation

P.O. BOX 21-8004
AUBURN HILLS, MI 48321-8004

CHASE MANHATTAN BANK USA, N.A.
WILMINGTON, DELAWARE

2400038817 62-26
311

3611-09

2400038817

COUNTER SIGNATURE

PAY
TO THE
ORDER OF

DATE

AMOUNT

1/9/02

\$21,679.13

VOID SIX MONTHS AFTER DATE OF ISSUE
NOT VALID OVER \$25000 UNLESS COUNTERSIGNED

AUTHORIZED SIGNER FOR

DaimlerChrysler Customer Center

ACCOUNT 7527

Ed Schmidt Jeep
26875 N Dixie Hwy
Perrysburg, OH 43552

Edward Lauke

DaimlerChrysler Customer Center

2400038817

2400038817

Payee Name: Ed Schmidt Jeep
Memo:

Date

Amount

1/9/02

\$21,679.13

42 Accident

Payee Name: Ed Schmidt Jeep
Memo:
Program Tracking: BYBACK

Date

Amount

Check No.

1/9/02

\$21,679.13

2400038817

<u>Loc</u>	<u>Account</u>	<u>Center</u>	<u>Description</u>
2100	1809100	0009999	1J4GL48K72W
2100	5793000	0094666	1J4GL48K72W

Expense Auth.

9027763

21,311.00

9027763

368.13

OHIO CERTIFICATE OF TITLE

COUNTY OF HAMILTON

STATE OF OHIO

No. [REDACTED]

ORIGINAL

ISSUE DATE
01/14/2002

BUYBACK:

THIS VEHICLE WAS RETURNED TO THE MANUFACTURER BECAUSE IT MAY NOT HAVE CONFORMED TO ITS WARRANTY

IDENTIFICATION NUMBER
1J4GL48K72W [REDACTED]

YEAR
2002

MAKE
JEEP

MAKE DESCRIPTION
JEEP (MFD. AFTE

COMMENTS

PURCHASE PRICE
\$00

BODY TYPE
SW

MODEL
SPR

MODEL DESCRIPTION

EXEMPT
NE

MILEAGE
61

CONVERSION

MLG BRAND ACTUAL

BRAND(S) BUYBACK VEHICLE

OWNER
DAIMLER CHRYSLER MOTORS CORP

11300 CORNELL PARK DR
CINCINNATI, OH 45242

PREVIOUS OWNER
ED SCHMIDT PONTAC GMC TRUCK INC

26875 N DIXIE HWY
PERRYSBURG, OH 43551-0000

LIEN DISCHARGE

Lienholder

LIEN DISCHARGE

Lienholder

by:

Authorized signature

date

CLERK OF COURTS LIEN CANCELLATION

by:

Deputy Clerk

date

by:

Authorized signature

date

CLERK OF COURTS LIEN CANCELLATION

by:

Deputy Clerk

date

WITNESS MY HAND AND OFFICIAL SEAL THIS 14th DAY OF JANUARY, 2002
(SEAL)



James Cissell

JAMES CISSELL
CLERK OF COURTS

COLLIERVILLE

DO NOT ACCEPT TITLE SHOWING ANY ERASURES, ALTERATIONS OR MUTILATIONS.



Predelivery Service Corporation

26115 Trowbridge
Inkster, MI 48141

Repair Order

Dealer Code 78003



Vin:	72W [REDACTED]
MileageIn:	2080
MileageOut:	2140
RO Type:	Warranty
Program Code	

RecRepair:	9/24/2001
Completion Date:	
Year:	02
Make:	Jeep
Model:	Liberty

Advisor:	1044-Esterline, Dave
CustomerName:	[REDACTED]
Authorization:	
DealerRoNum:	4059
PriorClaimNum	

Job 1 1295-Zelten, Paul

Cause & Cure

Concern Code: [REDACTED]

WHILE MAKING A RIGHT
TURN- BOTH FRONT
AIRBAGS DEPLOYED

DRB TEST/ OPEN SQUIB

REPLACE AIRBAG
CONTROL MODULE

Part Name	Failed	PartNumber	Qty	BuyPrice	LOP	FC	Hours
module	<input checked="" type="checkbox"/>	56010501ae	1	\$178.50	23115001	58	0.4
					85410000		1.0

SpecialService	SpcSvcInv	LOP	Hours	Amount
Safety Inspection	131388	95121212	1.0	\$50.00

*Demoit
Auto
Action*

**IMPARTIAL SERVICES GROUP, INC.
VEHICLE PICK-UP REQUEST**

Date: September 17, 2001
To: Road One

Telephone
Fax:

248-886-0534
248-886-0538

Customer Name: [REDACTED]
Zone: 42
VIN: 1J4GL48K72W [REDACTED]
Year: 2002
Model: Jeep Liberty Sport 4X4 Sport Utility 4-Dr
Color: XXXXXX
Brake/Steering: Yes

*****ATTENTION DRIVER*****

Call 24 hours in advance before going to pick up the vehicle to insure that the contact will be available to assist you when you arrive.

Pick Up Name: Ed Schmidt Jeep
Address: 26875 N Dixie Hwy
City: Perrysburg
State: OH
Zip Code: 43552
Telephone: 419 872-5440
Contact Name: Mike Cajowa

Special Remarks:
Delivery Name: Predelivery - Detroit
Street Address: 26115 Trowbridge
City: Inkster
State: MI
Zip Code: 48141
Telephone: 313-274-0000
Contact Name: Dave Esterline

*****ATTENTION DRIVER*****

Call Road One at 248-886-0534 if you have any problems picking up this vehicle at the dealership.

Final Destination: DETROIT AUTO AUCTION

ROAD ONE USE ONLY

Date Received:	
Transportation Cost Estimate:	
Delivery Completed By:	
Special Requirments:	
Signature:	

**IMPARTIAL SERVICES GROUP, INC.
VEHICLE PICK-UP REQUEST**

Date: October 4, 2001
To: Lyn Tetreau

Telephone
Fax:

248-886-0534
248-886-0538

Customer Name: [REDACTED]
Zone: 42
VIN: 1J4GL48K72W [REDACTED]
Year: 2002
Model: Jeep Liberty Sport 4X4 Sport Utility 4-Dr
Color: XXXXXXX
Brake/Steering: Yes

*****ATTENTION DRIVER*****

Call 24 hours in advance before going to pick up the vehicle to insure that the contact will be available to assist you when you arrive.

Pick Up Name: Predelivery - Detroit
Address: 26115 Trowbridge
City: Inkster
State: MI
Zip Code: 48141
Telephone: 313-274-0000
Contact Name: Dave Esterline

Special Remarks:

Delivery Name: Marshalling

*****ATTENTION DRIVER*****

Call Road One at 248-886-0534 if you have any problems picking up this vehicle at the dealership.

Final Destination: DETROIT AUTO AUCTION

ROAD ONE USE ONLY

Date Received:	
Transportation Cost Estimate:	
Delivery Completed By:	
Special Requirments:	
Signature:	

**IMPARTIAL SERVICES GROUP, INC.
VEHICLE PICK-UP REQUEST**

Date: January 18, 2002 Telephone 989-269-2161
To: Lyn Tetreau Fax: 989-269-2361

Customer Name: [REDACTED]
Zone: 42
VIN: 1J4GL48K72W [REDACTED]
Year: 2002
Model: Jeep Liberty Sport 4X4 Sport Utility 4-Dr
Color: XXXXXX
Brake/Steering: Yes

*****ATTENTION DRIVER*****

Call 24 hours in advance before going to pick up the vehicle to ensure that the contact will be available to assist you when you arrive.

Pick Up Name: Marshalling

Special Remarks:

Delivery Name: Detroit Auto Auction
Street Address: 20911 Gladwin
City: Taylor
State: MI
Zip Code: 48180
Telephone: 734-246-2293 Ext. 281
Contact Name: Debbie Holme

*****ATTENTION DRIVER*****

Call Road One at 989-269-2161 if you have any problems picking up this vehicle at the dealership.

Final Destination: DETROIT AUTO AUCTION

ROAD ONE USE ONLY

Date Received:	
Transportation Cost Estimate:	
Delivery Completed By:	
Special Requirments:	
Signature:	

REPLACEMENT AGREEMENT

In sole consideration of 1J4GL48K42W [REDACTED] I/We, [REDACTED] release DaimlerChrysler Motors Corporation, and its subsidiaries, dealerships, and all persons involved in the dispute resolution and vehicle repurchase or replacement transactions from all known and unknown claims, damages, costs, fees, loss of service, personal injuries and property damage related to a 2002, Jeep Liberty Sport 4X4 Sport Utility 4-Dr VIN: 1J4GL48K72W [REDACTED]. In return, I will transfer the ownership of the vehicle to DaimlerChrysler Motors Corporation with clear title, and will sign all papers DaimlerChrysler Motors Corporation requires to transfer the vehicle. I will return the vehicle with no original or substituted equipment missing and in an undamaged condition, except for normal wear and tear and any previously alleged defects.

I agree to indemnify and hold the above parties harmless from all further claims, costs or expenses relating to this claim. I expressly agree that the only consideration I will receive is that listed above and that DaimlerChrysler Motors Corporation has made no other promises to me. I accept the consideration listed above as full satisfaction of this claim.

Except as permitted by law, I agree not to talk about the details of this agreement and release to anyone. I understand that all the above parties deny any liability for this claim.

I fully understand and freely sign this release.

Date: 9-13, 2001

Si [REDACTED]

Signature

Witness Signature



2777 Stemmons Freeway . Suite 1425
Dallas, TX 75207
(214) 634-9100
Fax: (214) 634-2262

September 17, 2001

To: Dave Esterline
Co: Predelivery - Detroit
Fax: 313-274-5759

From: Darla Rollins
Zone: 42
Telephone: 214-634-9100

BUYBACK VEHICLE:

Customer Name: [REDACTED]
Vehicle VIN: 1J4GL48K72W [REDACTED]
Model: JEEP LIBERTY SPORT 4X4 SPORT UTILITY
4-DR
Color: XXXXXX
Year: 2002
State: OH

Regarding the repair of the above referenced vehicle, the customer complained of the following:

1. While Making A Right Turn Both Front Airbags Deployed.

Please attempt to have the vehicle repaired by: 10/17/2001

- If you are unable to Repair any of the above complaints, please notify ISG immediately.
- Please call before completing any repairs not related to the problems listed on this sheet.
- Once the repairs have been completed, please fax a copy of the R.O to 214-634-2262.
- If you are unable to meet the requested vehicle repair date or if you have any questions regarding the repair of this vehicle, please call me at 214-634-9100.

Thank you for your assistance and speedy attention to this matter.

DAIMLERCHRYSLER

DISCLOSURE NOTICE

1077
3023019

Rev. 11/98

(Check One)

In an effort to promote customer satisfaction, this vehicle was repurchased by DaimlerChrysler Motors Corporation due to the problem(s) listed below.

This vehicle was repurchased by DaimlerChrysler Motors Corporation pursuant to consumer warranty laws due to the defect(s)/nonconformity(ies) listed below.

VIN	YEAR	MAKE	MODEL
1J4GL48K72W [REDACTED]	02	JEEP	LIBERTY SPORT 4X4 SPORT UTILITY 4-DR

Reported Problem(s):

- While making a right turn both front airbags deployed.
-
-
-
-

Date Repaired or Other Comments:

- 10/1/01-Replace airbag control module.
-
-
-
-

Additional Information: _____

J. Selma, Agent 02/21/2002
 DaimlerChrysler Motors Corporation Representative Signature Date

Al Hampton - Agent 02/21/2002
 Auction Representative Signature/Title Date

The signature of the dealer representative constitutes agreement by the dealer that disclosure of the above information will be made to the retail customer at the time of sale of this vehicle as provided by law in the state in which it is resold. The dealer agrees to defend, indemnify, and hold harmless DaimlerChrysler Motors Corporation from all claims, causes of action, or any other liability arising from or related to the dealer's failure to make proper disclosure of the above information, whether or not disclosure is required by state or federal law. DaimlerChrysler Motors Corporation provides a supplemental Limited Warranty for a period of 12 months with unlimited mileage effective with the date of purchase or lease of this vehicle by the subsequent retail buyer. Additionally, this vehicle may be eligible for any remaining new vehicle warranty coverage.

MO Lynch Pres FEB 21 2002
 Dealer Representative Signature/Title Date

Customer Acknowledgement/Signature Date

MO LYNCH 26515
 Printed Name Dealer Code

Printed Name

NORTHERN AUTO CO INC, MI
 Dealership Name State

Street & No. City or Town and State



DAIMLERCHRYSLER

DISCLOSURE NOTICE

Rev. 11/98

(Check One)

In an effort to promote customer satisfaction, this vehicle was repurchased by DaimlerChrysler Motors Corporation due to the problem(s) listed below.

This vehicle was repurchased by DaimlerChrysler Motors Corporation pursuant to consumer warranty laws due to the defect(s)/nonconformity(ies) listed below.

VIN	YEAR	MAKE	MODEL
1J4GL48K72W [REDACTED]	02	JEEP	LIBERTY SPORT 4X4 SPORT UTILITY 4-DR

Reported Problem(s):

- While making a right turn both front airbags deployed.
-
-
-
-

Date Repaired or Other Comments:

- 10/1/01-Replace airbag control module.
-
-
-
-

Additional Information:

J. Selma, Agent 02/21/2002
 DaimlerChrysler Motors Corporation Representative Signature Date

At Hampton - Agent 02/21/2002
 Auction Representative Signature/Title Date

The signature of the dealer representative constitutes agreement by the dealer that disclosure of the above information will be made to the retail customer at the time of sale of this vehicle as provided by law in the state in which it is resold. The dealer agrees to defend, indemnify, and hold harmless DaimlerChrysler Motors Corporation from all claims, causes of action, or any other liability arising from or related to the dealer's failure to make proper disclosure of the above information, whether or not disclosure is required by state or federal law. DaimlerChrysler Motors Corporation provides a supplemental Limited Warranty for a period of 12 months with unlimited mileage effective with the date of purchase or lease of this vehicle by the subsequent retail buyer. Additionally, this vehicle may be eligible for any remaining new vehicle warranty coverage.

M O Lynch Pres. _____
 Dealer Representative Signature/Title Date

M O LYNCH Pres. 26515
 Printed Name Dealer Code

NORTHERN AUTO CO INC, MI
 Dealership Name State

[REDACTED] 4/4/02
 Street & No. Date

[REDACTED] MI
 City or Town and State



30700 Telegraph Road - Suite 4566

Warren, Michigan 48025-4532

Phone (248) 642-3232

Fax (248) 642-4558

Case 9027763

Vin # 1J4GL48K72W131388

Mr. Steven Avery

7 Bronson Pl

Toledo, OH 43608

Facsimile Cover Sheet
DaimlerChrysler Vehicle Investigation

Owner	[Redacted]
EAA No:	DF01-0446039
CAIR No:	9027763

HOT!

Transmitting	2	pages
If transmission not complete, please call the above phone number.		

To:	Fred Warbath
Phone No:	
Fax No:	330-725-2608

From:	Tina Martin
Date Faxed:	8-17-01
Due Date:	ASAP, please

Please acknowledge promptly by FAX or phone.

Receipt of CAIR and Accepting case for investigation YES NO DATE 8/18

Fax Coversheet for DaimlerChrysler (Service Associate Use Only)
(also fax to EAA for closure)

Closure Date: 8/20 DaimlerChrysler Fax Number: 248-512-8748

Number of pages (including cover) TO:

<input type="checkbox"/> Bennis (248) 944-7036	<input type="checkbox"/> Martell (248) 944-7038
<input checked="" type="checkbox"/> Bott (248) 944-7056	<input type="checkbox"/> Mucci (248) 944-7039
<input type="checkbox"/> Gilbert (248) 944-7037	<input type="checkbox"/> Porterfield (248) 944-7134

Comments: Tina - likely Tuesday A.M. There was a phone message at my house from Jay that Chrysler Engineering was there Friday 8/17 so that somewhat takes the heat off



Confidential Preliminary Vehicle Investigation Report

REF # 9027763

YEAR 02	MODEL Jen Liberty	VEHICLE IDENTIFICATION NUMBER 1J4GL48K72W	ODOMETER 20780	M.D.H. 060722	DELIVERY DATE 6/30/01
CITY Toledo		STATE OH	[Redacted]		
SELLING DEALER NAME Ed Schmidt	ZONE 42	DLR. CODE 26571	CITY Perrysburg	STATE OH	
CHRYSLER REPRESENTATIVE - PRINT Fred Harbath EAA	ZONE Medina OH	PHONE (330) 725-5547	REPAIR ESTIMATE \$ None Made		

INTERVIEW

INTERVIEW WITH <input checked="" type="checkbox"/> DRIVER <input type="checkbox"/> OWNER <input type="checkbox"/> OTHER	INTERVIEW DATE 08/19/01	DATE OF INCIDENT 08/16/01	TIME OF INCIDENT 8:00 AM	INSPECTION DATE 08/20/01
--	----------------------------	------------------------------	-----------------------------	-----------------------------

DESCRIPTION OF INCIDENT (VEHICLE DAMAGE, OCCUPANT INJURY, AND ROAD SURFACE)

Driver's and/or occupant's description of incident
 What? When? Where? How?
 Exact order of events
 Did this happen before?

Pulling out of a video store and both bags went off at the same time

Sore arm

Personal Injury: Were there Personal Injuries? Yes No If yes, complete section "L."

IMPORTANT: SHOW TO NO ONE. DRAW NO CONCLUSIONS

DIRECTIONS: • FILL OUT UPPER PART OF FC
 • FOR "FIRE" USE FORM 84-130
 • FOLLOW INSTRUCTIONS FOR
 • FOLLOW INSTRUCTIONS FOR
 • ATTACH ANY ADDENDUMS TO

Case 9027763
 Vin # 1J4GL48K72W
 Toledo, OH

COMMENTS: • NOTE ANY MISSING COMPONENTS AND WHO REMOVED THEM.
 • NOTE ANY AFTERMARKET EQUIPMENT INSTALLED AND BY WHOM.

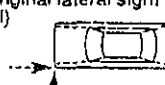
ALLEG.	PHOTOGRAPH REQUIRED	INFORMATION	EVALUATION
General A	<input type="checkbox"/> From center of vehicle front every 45 degrees (6 total) <input type="checkbox"/> If crash damaged — perspective from every corner of vehicle down both original lateral sight lines. (8 total)  <input type="checkbox"/> Send neg. & 2 sets of prints	<input checked="" type="checkbox"/> Police report <input type="checkbox"/> Vehicle service file <input type="checkbox"/> Any reports/photos by others <input type="checkbox"/> Location of inspection <i>Ed Schmidt 26875 N. Dixie Hwy Perrysburg OH 43552</i>	<input type="checkbox"/> Driver's and/or occupant's description of incident <input type="checkbox"/> Complete exterior damage diagram and measurements on last page. <input type="checkbox"/> What? When? Where? How? <input type="checkbox"/> Exact order of events <input type="checkbox"/> Did this happen before?
Airbag(s) B	<input type="checkbox"/> Steering Wheel <input type="checkbox"/> Airbag(s) <input type="checkbox"/> Knee Blockers <input type="checkbox"/> All possible body contact areas <input type="checkbox"/> All code readings using DRB II <i>As found dash air bag check light is OK</i>	<input type="checkbox"/> Record: <input type="checkbox"/> Was Airbag deployed? Driver <input checked="" type="checkbox"/> Yes <input type="checkbox"/> No Passenger <input checked="" type="checkbox"/> Yes <input type="checkbox"/> No <input type="checkbox"/> Type of Steering Wheel <input checked="" type="checkbox"/> Tilt <input type="checkbox"/> Std. <input type="checkbox"/> Condition of Steering Wheel <i>Good</i> <input type="checkbox"/> Condition of Steering Wheel Mounting (measure column collapse) <i>Normal</i>	<input type="checkbox"/> Evidence of tampering or disassembly? <input type="checkbox"/> Yes <input checked="" type="checkbox"/> No <input type="checkbox"/> Use DRB II <input type="checkbox"/> Record Existing Readings 1. <i>See Attached</i> 2. <i>RO</i> <input type="checkbox"/> Record Stored Readings 1. <i>See Attached</i> 2. <i>RO</i> 3. _____ <input type="checkbox"/> Important: DO NOT ERASE DRB II READINGS. <i>DRB Check by Ed Schmidt RO 535058td 8/20/01 paid by F. Harbath EAA for Chrysler Corp</i> PN 56010501 AE Ver 5.3

Confidential

REF. # 9027763

ALLEG.	PHOTOGRAPH REQUIRED	INFORMATION	EVALUATION
C Sudden Acceleration or Throttle Hold	<input type="checkbox"/> Accelerator Pedal <input type="checkbox"/> Throttle Cable <input type="checkbox"/> Return Springs <input type="checkbox"/> Floor Mats	<input type="checkbox"/> Describe any Accelerator Pedal interference with Carpet/Mat <div style="text-align: center;">NA</div>	<input type="checkbox"/> DRB II Tests <input type="checkbox"/> Disconnect Cable at Throttle Body/Carburetor lever; operate: <input type="checkbox"/> Lever <input type="checkbox"/> Cable <input type="checkbox"/> Any restricted motion? <input type="checkbox"/> Yes <input type="checkbox"/> No <input type="checkbox"/> If safe and permitted to drive - attempt to duplicate and check Service Brakes at reported speed.
D Brakes	<input type="checkbox"/> Items in Information Block.	<input type="checkbox"/> Check and record Brake Fluid Level. _____ <input type="checkbox"/> Check and record if Vacuum Hose is connected. <input type="checkbox"/> Yes <input type="checkbox"/> No <input type="checkbox"/> Check and record for Brake Line Leaks. <input type="checkbox"/> Yes <input type="checkbox"/> No <input type="checkbox"/> Pull Wheels, check Linings and record condition. <input type="checkbox"/> Check Brake Pedal, does it set firm? <input type="checkbox"/> Yes <input type="checkbox"/> No <input type="checkbox"/> Check operation of Parking Brake. <input type="checkbox"/> Check operation of ABS System.	With Engine off: <input type="checkbox"/> Apply Brake fully 3 or 4 times. <input type="checkbox"/> With light force held to Pedal, start the Engine. <input type="checkbox"/> Note reaction of Pedal and record: _____ <input type="checkbox"/> ABS System DRB II test readouts _____
E Steering	<input type="checkbox"/> Complete Steering System Including as required: <ul style="list-style-type: none"> • Rack & Pinion • Linkage • C/V & Universal Joints • Column • Belts & Pulleys 	<input type="checkbox"/> Record if: <input type="checkbox"/> Manual Steering <input type="checkbox"/> <input type="checkbox"/> Check Fluid Level _____ <input type="checkbox"/> Record if Drive Belts tight <input type="checkbox"/> Check for Hose/System _____ <input type="checkbox"/> Check condition of Steering Linkage/Column, record deformation or loose connections. _____	<input type="checkbox"/> Unlock key and turn Wheels fully right and left. <input type="checkbox"/> start Engine and turn Wheels left. <div style="text-align: center;"> <p>Case 9027763</p> <p>Vin # 11A...</p> <p>Toledo, OH</p> </div>
F Transmission	<input type="checkbox"/> Entire Transmission with pictures and closeup of leaks, if any.	<input type="checkbox"/> Record: Type of Transmission? <input type="checkbox"/> Auto <input type="checkbox"/> Std. How many Speeds? <input type="checkbox"/> 3 <input type="checkbox"/> 4 <input type="checkbox"/> 5 <input type="checkbox"/> Record Gear Shift location at time of Inspection _____ <input type="checkbox"/> Run Shift Lever thru all shift positions and record "Feel of Galling" _____ <input type="checkbox"/> Is Shift Indicator properly aligned? <input type="checkbox"/> Yes <input type="checkbox"/> No	If safe and permitted to drive vehicle: <input type="checkbox"/> Drive Vehicle and record feel of Gear during each Gear Shift _____ <input type="checkbox"/> Does Parking Pawl engage? <input type="checkbox"/> Yes <input type="checkbox"/> No <input type="checkbox"/> If lockup is alleged - check rotation of Transmission in all Gears. <input type="checkbox"/> Check starting ability in park and neutral. Check to see that start does not occur in other selector positions.
G Engine Stall/Drivability	<input type="checkbox"/> Complete Engine Compartment Including as required: <ul style="list-style-type: none"> • Underhood Emissions Label • Engine Wiring/Connections • Vacuum Hoses • Fuel Lines • Exhaust System • Spark Plugs • Connections 	<input type="checkbox"/> Record type of Spark Plugs (location of unique plugs). <div style="text-align: center;">NA</div>	If safe and permitted to: <input type="checkbox"/> Try to duplicate Allegation Off Hiway <input type="checkbox"/> DRB II or I/P Fault Code Test _____ _____

Confidential

REF # 9027763

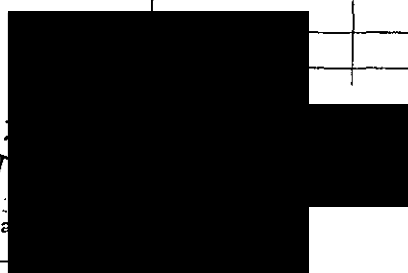
ALLEG.	PHOTOGRAPH REQUIRED	INFORMATION	EVALUATION								
H Seat/Shoulder Belts	<input type="checkbox"/> Overall of seat belts I/B and O/B. <input type="checkbox"/> Close ups of any irregularities on belts. <input type="checkbox"/> Shoulder Belt Pendulum <input type="checkbox"/> Latchplate wear <input type="checkbox"/> Close up of D-ring to show belt loading.	<input type="checkbox"/> Locate seat belt labels and record ALL information (Some labels are sewn to webbing, other labels are on retractor frame. Inboard seat belt labels are near floor.) <input type="checkbox"/> Record ALL information stamped on latchplate.	If allowed, function belts to insure they FUNCTION PROPERLY, note results: Do they latch? <input type="checkbox"/> Yes <input type="checkbox"/> No Do they release? <input type="checkbox"/> Yes <input type="checkbox"/> No Do they retract? <input type="checkbox"/> Yes <input type="checkbox"/> No <input type="checkbox"/> Does Inertia Pendulum System run freely? <input type="checkbox"/> Yes <input type="checkbox"/> No								
I Seat	<input type="checkbox"/> Overall of seat <input type="checkbox"/> Close ups of damage	<input type="checkbox"/> Existing location of recliner - number of teeth from rear of sector gear to rear edge of Pawl (crayon mark location). <input type="checkbox"/> Existing location of seat adjuster (window or tooth location from rear of adjuster). <input type="checkbox"/> Existing location of head restraint (measure gap under head restraint).	<input type="checkbox"/> If allowed, adjust all functions of seat and return to original location <input type="checkbox"/> Describe functions <input type="checkbox"/> Note any irregular orientations								
J Tires	<input type="checkbox"/> Each Tire with visible location label, insuring all Tire identification and Tread wear is documented. <input type="checkbox"/> All damaged Wheel and Rim area including impacted foreign material.	Record: <input type="checkbox"/> Tire Size <input type="checkbox"/> Brand <input type="checkbox"/> Ratings <input type="checkbox"/> DOT No. (I/B Side) <input type="checkbox"/> Rim Size <input type="checkbox"/> Tread Depth	<table border="1"> <thead> <tr> <th>Front Left</th> <th>Front Right</th> <th>Rear Left</th> <th>Rear Right</th> </tr> </thead> <tbody> <tr> <td>NA</td> <td></td> <td></td> <td></td> </tr> </tbody> </table>	Front Left	Front Right	Rear Left	Rear Right	NA			
Front Left	Front Right	Rear Left	Rear Right								
NA											
K Axle Lockup	<input type="checkbox"/> Entire Axle and close up of Leaks	While on holst: <input type="checkbox"/> Rear Wheel Drive Record amount of Lateral Axle Movement on ea <input type="checkbox"/> Trans. Axle - rotate Wheels <input type="checkbox"/> Note function									
L Occupant Contact	<input type="checkbox"/> Windshield <input type="checkbox"/> All areas of occupant contact on interior and exterior. <input type="checkbox"/> Close ups of stains, skin, hair, cloth <input type="checkbox"/> Exterior and interior damage	<input type="checkbox"/> See Seat Belt/Seats if applicable <input type="checkbox"/> Occupant contact description									

ADDITIONAL COMMENTS

At this contact also attended by TAW + Chrysler engineering they were to remove the module to take back to pull additional information out of the module

Confidential

REF. # 9027763

Exterior Damage Diagram an

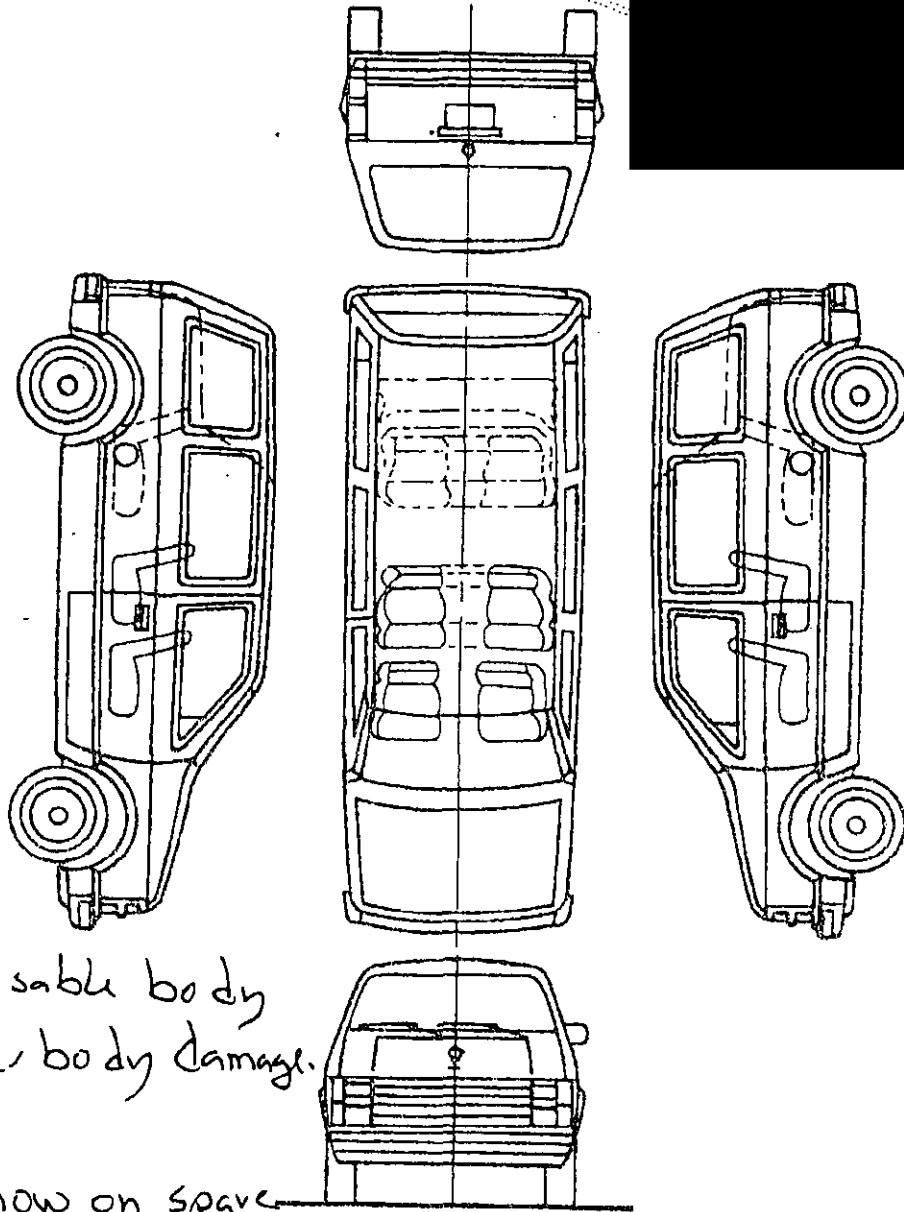
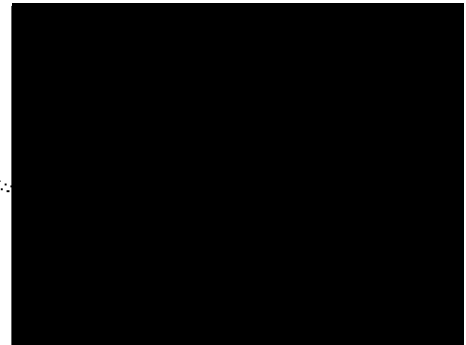

No visible body or under body damage.

RR Tire now on spare as there is a nail puncture mark in the tread. Nothing noted that should deploy the air bags

Sketch damage on all views. Include dimensions to describe and locate each damaged area and maximum depth of penetration for each impact. Annotate observations which might be useful in reconstructing the accident (e.g., direction of scrapes, markings on tires and wheels, etc.). Take photographs.

ED SCHMIDT

AUTOMOTIVE GROUP



ED SCHMIDT PONTIAC-GMC, INC.
26875 N. Dixie Hwy., PERRYSBURG, OH. 43551
(419) 874-4331



ED SCHMIDT FORD
9760 Waterville-Swanton Rd.
WATERVILLE, OH. 43566
(419) 878-8151

THE TRUCK STORE

ed schmidt



1270 CONANT ST. • MAUMEE, OHIO 43537 • PHONE (419) 872-4488

Please send all payments to: Ed Schmidt Pontiac-GMC, Inc. • 1280 Conant St. • Maumee, Ohio 43537
Visit us on the web at: www.edschmidt.com

CUSTOMER NO. 102236	ADVISOR DENNIS KINNEY	1581	TAG NO. 3052	INVOICE DATE 08/20/01	INVOICE # CHCS535056
LABOR RATE 69.00	LICENSE NO.	MLEAGE 2,078	CHASSIS BR SILVER/D	02	3154
YEAR / MAKE / MODEL 02/JEEP/LIBERTY/LIBERTY 4WD SPORT	DELIVERY DATE 06/30/01	DELIVERY MILES 61	SELLING DEALER NO.	PROB 08/08/01	
VEHICLE ID NO. 1J4GL48K72W	F T E NO.	P O NO.	08/20/01		
COMMENTS C# 06-14-01	E# NO MSO				

LABOR & PARTS

J# 1-11CHZ GENERAL REPAIRS 1 HOUR \$11.00 TECH(S) 6094
 INSPECTION FOR AIR BAG DEPLOYMENT
 INSPECT FOR STORED AND EXISTING CODES
 AIR BAG CODES: ACTIVE 1.DRIVER SQUIB OPEN #1 2.PASS SQUIB OPEN #1 3.DRIVER SQUIB CIRCUIT OPEN #2 4.PASS SQUIB CIRCUIT OPEN #2 5.DRIVER SEAT BELT TENSIONER OPEN STORED CODE 1.DRIVER SQUIB #1 CIRCUIT OPEN #2 PASS SQUIB #1 CIRCUIT OPEN 3.DRIVER SQUIB #1 SHORT TO GROUND 4.DRIVER SQUIB #2 CIRCUIT OPEN 5.PASS SQUIB #2 CIRCUIT OPEN 6.DRIVER SQUIB #2 SHORT TO GROUND 7.DRIVER SEAT BELT TENSIONER OPEN

JOB # 1 TOTAL LABOR & PARTS 69.00

ESTIMATE

CUSTOMER HEREBY ACKNOWLEDGES RECEIVING ORIGINAL ESTIMATE OF \$69.00 (+TAX)
TOTALS

CASH () DISCOVER () CHECK # ()	TOTAL LABOR	69.00
PAID AMERICAN EXPRESS () MASTERCARD/VISA ()	TOTAL PARTS	0.00
ACCTS RECEIVABLE ACCOUNT # ()	TOTAL SUBLET	0.00
	TOTAL G.O.G.	0.00
	TOTAL MISC CHG	0.00
	TOTAL MISC DISC	0.00
	TOTAL TAX	0.00

TOTAL INVOICE \$ 69.00

THANK YOU FOR CHOOSING THE ED SCHMIDT AUTO GROUP FOR YOUR AUTOMOTIVE NEEDS!!!

Case 9027763
Vin # 1J4GL48K72W

Toledo, OH

00: 215201716994
ED SCHMIDT PONTIAC GMC
1280 CONANT ST
MAUMEE, OH 43537

00: DATE 08/20/01
ACCT # 44639
EXP DATE 06/02
CARD TYPE MASTERCARD
TRRN TYPE SALE
TERMINAL # 00831820
AUTH CODE 379211
RECORD # 002
AMOUNT \$69.00

In the event that you, the customer, authorize commencement but do not authorize completion of a repair or service, a charge will be imposed for disassembly, reassembly or partially completed work. Such charge will be directly related to the actual amount of labor and parts involved in the inspection, repair or service.
 DISCLAIMER OF WARRANTIES: Any warranties sold herein are those made by the manufacturer of those products. The seller, ED SCHMIDT PONTIAC GMC, INC., THE ED SCHMIDT TRUCK STORE and ED SCHMIDT FORD, L.L.C. hereby expressly disclaims all warranties, either express or implied, including any implied warranties of merchantability or fitness for a particular purpose regarding any products or services provided, unless otherwise indicated on the repair order. ED SCHMIDT PONTIAC GMC, INC., THE ED SCHMIDT TRUCK STORE, and ED SCHMIDT FORD, L.L.C., neither assumes nor authorizes any other person to assume for it any liability in connection with the sale of said products or services. This disclaimer by ED SCHMIDT PONTIAC GMC, INC., THE ED SCHMIDT TRUCK STORE, and ED SCHMIDT FORD, L.L.C. in no way affects the terms of performance of the manufacturer's warranty.
 This dealership utilizes the hours published in the manufacturer's labor/time guide which reflect an average time requirement for the performance of specific vehicle repairs, and which may, therefore, be either more or less than the actual clock time in any given instance.
 * SUPPLIES: A token charge equivalent to 1% of the labor charge to a maximum of \$25.00 is included for supplies used on your vehicle. Applicable supply items are: Nuts, bolts, washers, tape, pins, aerospray, sheetrock, solvent, rags, carburetor cleaner, towels, solder, battery cleaner, wire, window sealer, etc.

EA12-001

CHRYSLER

10-4-2012

ENCLOSURE 4

FIELD DATA SUBJECT

CAIRs Backup

EA12-001

CHRYSLER

10-4-2012

ENCLOSURE 4

FIELD DATA SUBJECT

CAIRs Backup

ARCHITECTURE
CAIR*
10174069



22:13



Jeep



NO
PARKING

9594

PARK

22:14



NO
PARKING

22:14



DAVE

NO
PARKING

8594

M

22:14

DAVE
MARSTON



22:15



Quick Lane

LIBERTY 4x4

4x4

4x4

22:15



22:15



22:15



22:15



22 1:16



Jeep

22:19



CALL FOR SERVICE
CALL FOR SERVICE
CALL FOR SERVICE
CALL FOR SERVICE
CALL FOR SERVICE
CALL FOR SERVICE
CALL FOR SERVICE
CALL FOR SERVICE
CALL FOR SERVICE
CALL FOR SERVICE

22 1:20

Jeep



WRANGLER
GOOD YEAR

22128



WRANGLER

22:28









22 1:30

December 13, 2002

ICC

Ms. Marcia Bailey Product Litigation 485-13-62

A. Gilbert Special Investigations 431-00-00

Reference: 1J4GL48K62W [REDACTED] CAIR #10174069, [REDACTED]

Dear Ms. Bailey:

Please find enclosed attorney letter dated November 6, 2002 and our files on this matter. I am forwarding this to your office for review and handling due to the possible magnitude of this incident.

Sincerely,

A. L. Gilbert
Special Investigations
(248) 944-7037

Enclosure(s)

ALG/kat

*Please
impr 10/74069*

Robert E Cousineau

07/01/02 12:45 PM

To: Arthur L Gilbert/FRC/DCC/DCX@wk-America
cc: Robin T Hartzell/CLTB/DCC/DCX@wk-America, David E
Friedel/CLTB/DCC/DCX@wk-America
Subject: 2002 Liberty Airbag Deployed

Mr. Gilbert,

The STAR Center received the following call about a 2002 Liberty in which the airbags deployed, but not in an accident situation. Please contact Paul Hanson at the dealer. Thanks for your assistance.

Bob Cousineau

Daimler Chrysler
S.T.A.R. Center
Body / Chassis / Electrical Group
Phone: T/L 722-7075
Outside: 248-512-7075
Fax: 248-512-7904
EMAIL: rec4@dcx.com
CIMS 429-08-05

*7-1-02
Request
Inspection*

10174069

DAW STAR April 19 2002 Version: 7.4.3 - [Case Update]

CASE UPDATE

Case No: [REDACTED] Status: [REDACTED] Date: [REDACTED]

Vehicle: [REDACTED] VIN: [REDACTED] Make: [REDACTED] Model: [REDACTED]

Year: [REDACTED] Color: [REDACTED] Mileage: [REDACTED] License: [REDACTED]

Owner: [REDACTED] Address: [REDACTED] City: [REDACTED] State: [REDACTED] Zip: [REDACTED]

Phone: [REDACTED] Email: [REDACTED]

Case Description: [REDACTED]

Incident No: [REDACTED] Date: [REDACTED] Time: [REDACTED] Location: [REDACTED]

Police No: [REDACTED] Agency: [REDACTED]

Officer: [REDACTED]

Case Details:

Customer complaint - air bag light came on for about 15 seconds - then the driver side airbag deployed - there was a 5 second delay, then the pass side bag deployed. There were no reported injuries.
:CW008-07/01/2002

Advised tech not to do anything until special investigations contacts him. Contact Paul Hansen. Sent to T2 for further action.
:CW008-07/01/2002

System: [REDACTED] Status: [REDACTED] Date: [REDACTED]



28635 Mound Road
Warren, Michigan 48092-3499
(586) 753-3326
FAX (586) 753-3335

Facsimile Cover Sheet
DaimlerChrysler Vehicle Investigation

Owner: [REDACTED]

Project No. DAIM-0001

CAIR No.: 10174069

TO: Cal Compe

FROM: Tina Martin

Date Sent: 7-2-02

DUE DATE: 7-8-02

***PLEASE ACKNOWLEDGE PROMPTLY BY FAX OR EMAIL**

***Receipt of CAIR and Accepting case for investigation?** Yes No

Date: 07/02/02

Coversheet for DaimlerChrysler (Service Associate Use Only)
(Also fax or email to EAA for closure)

*Closure Date: 7-3-02

DaimlerChrysler Fax No.: 248- 512-8748

Bennis (248) 944-7036

Martell (248) 944-7038

Bott (248) 944-7056

Susalla (248) 944-7149

Gilbert (248) 944-7037

Porterfield (248) 944-7134

Comments: _____

107/01/02 CAIR Data File

10174069.txt

CAIR: 10174069 82 1/ 1 Page: 1
Tmp Address:

Comp [REDACTED]
Cust [REDACTED]
AD1: [REDACTED]
AD2: [REDACTED]
Cty/St/ZIP: ARBOR VITAE
Co-own:

UNKNOWN
Ph [REDACTED] H
Ph [REDACTED]

WI [REDACTED]

Company:
Rep:
AD1:
AD2:
Cty/St/ZIP:

Ph:
Ph:
Cntry: Lang:

Status and Notes -----

Opened by: ALG2 Open Dt: 070102 Typ: L
Stat: 0 Closed by: Closed Dt:
Alrt: A Curresp: 82E 82
Lst Upd: 070102 1540P ALG2 82
Cntc Typ: T Orig: C Mail Ctgr:
Dt on Ltr: Exec:
Resp Ltr: Resp Ltr Dt:

Check Information -----

Ck Amt: \$.00 S:
Payee:
Addr1:
Addr2:
City:
St/ZIP:

Vehicle Information -----

VIN: 1J4GL48K62V [REDACTED] YR/Model: 02 JEEP LIBERTY SPORT 4X4 SPORT UTILITY 4-DR
Sl's Zn/Sl's/Svc/Dlr: 55 F F 43956 DAVE MARSTON MOTORS IN In Srv Date: 04/30/02
Svc Zn/Sl's/Svc/Dlr: 55 F F 43956 DAVE MARSTON MOTORS IN Curr Mi/Km: M 3900
WCC: 336 - /36 3/36 0 7
CSC: [REDACTED] - 7/100,000 EXTEND LTD PTWN WARR

General Narrative -----

REASONS FOR CONTACT:

- 1) Air Bag Inquiry - Both Air Bags deployed

*--> NARRATIVE ADDED BY A. L. GILBERT ON 07/01/02 AT 03:43PM

7-1-02 e mail from S.T.A.R. center.
owner alleges air bag light came on for 15 seconds and then drivers side air bag deployed then after 5 seconds passenger side deployed. no accident.

location:

43956 DAVE MARSTON MOTORS INC CJDY
9594 HWY 70 WEST MINOCQUA WI 54548 715-356-3242

contact: paul hanson

7-1-02 please contact dealer and owner if possible and arrange for inspection on deployment of air bags. need drb codes and times.

check for hidden/prior damage. thanks. art gilbert

CAIR NUMBER 10174069 REQUEST EAA INSPECTION 07-01-2002 15:45

DAIMLERCHRYSLER

Confidential Preliminary Vehicle Investigation Report

REF # 101746

YEAR 02	MODEL LIBERTY JEEP SET 4x4	VEHICLE IDENTIFICATION NUMBER 1T4BN48K62W	ODOMETER 4838	M.D.H. 0442319	DELIVERY DATE 04/30/02
CITY ARBOR VITAE	STATE WI	ZIP [REDACTED]	BUSINESS PHONE ()	HOME PHONE ()	
SELLING DEALER NAME DAVE MARSTON Motors, Inc	ZONE 55	DLR. CODE 43956	CITY MINOCQUA	STATE WI	
CHRYSLER REPRESENTATIVE - PRINT CAL COMPE	ZONE 55	PHONE 920-897-3201	<input type="checkbox"/> MINOR <input checked="" type="checkbox"/> MODERATE <input type="checkbox"/> MAJOR	REPAIR ESTIMATE \$ No estimate	
INTERVIEW					
INTERVIEW WITH <input type="checkbox"/> DRIVER <input type="checkbox"/> OWNER <input type="checkbox"/> OTHER	NAME [REDACTED]	INTERVIEW DATE	DATE OF INCIDENT 06/27/02	TIME OF INCIDENT 11:35 AM	INSPECTION DATE 07/03/02
DESCRIPTION OF EVENT (MODELS OF WEATHER CONDITIONS AND ROAD SURFACE) DRIVER STATED HE SOUTHBOUND ON Int 94 ABOUT 10 MILES NORTH OF MADISON, WI TRAVELING 65MPH. HE WAS DRIVING IN STOP & GO TRAFFIC FOR ABOUT 15-20 MINUTES AND JUST WHEN HE GOT OUT OF IT & GOT UP TO SPEED AN ALARM WENT OFF. HE LOOKED AT THE DASH & SAW THE "AIRBAG" LAMP ON.					
<input type="checkbox"/> Driver's and/or occupant's description of incident <input type="checkbox"/> What? When? Where? How? <input type="checkbox"/> Exact order of events <input type="checkbox"/> Did this happen before?					
Personal Injury: Were there Personal Injuries? <input type="checkbox"/> Yes <input checked="" type="checkbox"/> No If yes, complete section "L." (CONT)					

IMPORTANT: SHOW TO NO ONE & DRAW NO CONCLUSIONS

- DIRECTIONS:
- FILL OUT UPPER PART OF FORM.
 - FOR "FIRE" USE FORM 84-130-6950.
 - FOLLOW INSTRUCTIONS FOR SECTION "A" ON ALL VEHICLES.
 - FOLLOW INSTRUCTIONS FOR SPECIFIC ALLEGATIONS FOR THIS VEHICLE.
 - ATTACH ANY ADDENDUMS TO REPORT AND STATE SECTION IT PERTAINS TO.

- COMMENTS:
- NOTE ANY MISSING COMPONENTS AND WHO REMOVED THEM.
 - NOTE ANY AFTERMARKET EQUIPMENT INSTALLED AND BY WHOM.

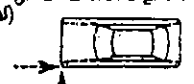
ALLEG.	PHOTOGRAPH REQUIRED	INFORMATION	EVALUATION
A General <input checked="" type="checkbox"/> From center of vehicle front every 45 degrees (8 total) <input type="checkbox"/> If crash damaged — perspective from every corner of vehicle down both original lateral sight lines. (8 total)  <input type="checkbox"/> Send neg. & 2 sets of prints	<input checked="" type="checkbox"/> Police report NONE <input checked="" type="checkbox"/> Vehicle service file NONE <input type="checkbox"/> Any reports/photos by others NO <input type="checkbox"/> Location of inspection	<input type="checkbox"/> Driver's and/or occupant's description of incident <input type="checkbox"/> What? When? Where? How? <input type="checkbox"/> Exact order of events <input type="checkbox"/> Did this happen before?	<input type="checkbox"/> Complete exterior damage diagram and measurements on last page.
B Airbag(s) <input checked="" type="checkbox"/> Steering Wheel <input checked="" type="checkbox"/> Airbag(s) <input type="checkbox"/> Knee Blockers <input checked="" type="checkbox"/> All possible body contact areas <input type="checkbox"/> All code readings using DRB II	<input type="checkbox"/> Record: <input checked="" type="checkbox"/> Was Airbag deployed? Driver <input checked="" type="checkbox"/> Yes <input type="checkbox"/> No Passenger <input checked="" type="checkbox"/> Yes <input type="checkbox"/> No <input type="checkbox"/> Type of Steering Wheel <input checked="" type="checkbox"/> Tilt <input type="checkbox"/> Std. <input checked="" type="checkbox"/> Condition of Steering Wheel STRAIGHT <input checked="" type="checkbox"/> Condition of Steering Wheel Mounting (measure column collapse) NO DAMAGE	<input type="checkbox"/> Use DRB II <input type="checkbox"/> Record Existing Readings 1 _____ 2 _____ <input type="checkbox"/> Record Stored Readings 1 _____ 2 _____ 3 _____ <input checked="" type="checkbox"/> Important: DO NOT ERASE DRB II READINGS. AIRBAG LAMP COMES ON WITH IGNITION & STAYS ON	<input type="checkbox"/> Evidence of tampering or disassembly? <input type="checkbox"/> Yes <input checked="" type="checkbox"/> No UNABLE TO OBTAIN READINGS WITH DRB

Confidential

REF. # 10174067

ALLEG.	PHOTOGRAPH REQUIRED	INFORMATION	EVALUATION																								
H Seat/Shoulder Belts	<input type="checkbox"/> Overall of seat belts I/B and O/B. <input type="checkbox"/> Close ups of any irregularities on belts. <input type="checkbox"/> Shoulder Belt Pendulum <input type="checkbox"/> Latchplate wear <input type="checkbox"/> Close up of D-ring to show belt loading.	<input type="checkbox"/> Locate seat belt labels and record ALL information (Some labels are sewn to webbing, other labels are on retractor frame. Inboard seat belt labels are near floor.) <u>BELT-LEFT-03102R</u> <u>TENSIONER IS DISABLED</u> <input type="checkbox"/> Record ALL information stamped on latchplate.	If allowed, function belts to insure they FUNCTION PROPERLY, note results: Do they latch? <input checked="" type="checkbox"/> Yes <input type="checkbox"/> No Do they release? <input checked="" type="checkbox"/> Yes <input type="checkbox"/> No Do they retract? <input type="checkbox"/> Yes <input checked="" type="checkbox"/> No <input type="checkbox"/> Does Inertia Pendulum System run freely? <input type="checkbox"/> Yes <input type="checkbox"/> No																								
I Seat	<input type="checkbox"/> Overall of seat <input type="checkbox"/> Close ups of damage <u>NA</u>	<input type="checkbox"/> Existing location of recliner - number of teeth from rear of sector gear to rear edge of Pawl (crayon mark location). <input type="checkbox"/> Existing location of seat adjuster (window or tooth location from rear of adjuster). <input type="checkbox"/> Existing location of head restraint (measure gap under head restraint).	<input type="checkbox"/> If allowed, adjust all functions of seat and return to original location <input type="checkbox"/> Describe functions <input type="checkbox"/> Note any irregular orientations																								
J Tires	<input type="checkbox"/> Each Tire with visible location label, insuring all Tire identification and Tread wear is documented. <input type="checkbox"/> All damaged Wheel and Rim area including impacted foreign material. <u>NA</u>	Record: <input type="checkbox"/> Tire Size <input type="checkbox"/> Brand <input type="checkbox"/> Ratings <input type="checkbox"/> DOT No. (I/B Side) <input type="checkbox"/> Rim Size <input type="checkbox"/> Tread Depth	<table border="1"> <thead> <tr> <th>Front Left</th> <th>Front Right</th> <th>Rear Left</th> <th>Rear Right</th> </tr> </thead> <tbody> <tr><td> </td><td> </td><td> </td><td> </td></tr> <tr><td> </td><td> </td><td> </td><td> </td></tr> <tr><td> </td><td> </td><td> </td><td> </td></tr> <tr><td> </td><td> </td><td> </td><td> </td></tr> <tr><td> </td><td> </td><td> </td><td> </td></tr> </tbody> </table>	Front Left	Front Right	Rear Left	Rear Right																				
Front Left	Front Right	Rear Left	Rear Right																								
K Axle Lockup	<input type="checkbox"/> Entire Axle and close up of Leaks <u>NA</u>	<input type="checkbox"/> While on hoist: <input type="checkbox"/> Rear Wheel Drive Record amount of Lateral Axle Movement on each side and will Wheels turn <input type="checkbox"/> Trans. Axle - rotate Wheels <input type="checkbox"/> Note function																									
L Occupant Contact	<input type="checkbox"/> Windshield <input type="checkbox"/> All areas of occupant contact on interior and exterior. <input type="checkbox"/> Close ups of stains, skin, hair, cloth <input type="checkbox"/> Exterior and interior damage	<input type="checkbox"/> See Seat Belt/Seats if applicable <input type="checkbox"/> Occupant contact description <u>No EVIDENCE of occupant contact</u>																									

ADDITIONAL COMMENTS

7-2-02 Vehicle inspect - No EVIDENCE of ANY IMPACT ON VEHICLE ANYWHERE, INCLUDING UNDERCARRIAGE - WE WERE UNABLE TO OBTAIN A DRB READING - CALLED TECH CENTER - SPOKE TO PAT. HE SAID TO TRY THE DRB ON ANOTHER JEEP LIBERTY TO SEE IF IT WORKS AND IF IT DOES THEN THE REASON WE CAN'T GET A READING IS BECAUSE THE MODULE IS BAD OR BURNED UP. HE SAID TO TELL THE DEALER TO GO AHEAD & REPAIR VEHICLE. I TOLD SER MGR & ALSO TOLD him to KEEP DEFECTIVE PARTS THIS INCIDENT ALSO CAUSED SEATBELT TENSIONER TO FAIL.

Description of Event (cont)

He said he quickly got the owners manual out and opened it across the steering wheel - He smelled an odor like electrical wires burning and then the driver airbag deployed. In just seconds the passenger bag deployed. He was able to control the vehicle without hitting anyone or anything. He drove to the Jeep dealer in Madison WI and asked if they could check to determine what caused the bags to deploy and if it was OK to drive. They told him they didn't think there was anything they could do & it was OK to drive and he should go back to where he bought it. So, he said he cut the bags off and returned the car to the selling dealer. He stated prior to the incident there wasn't anything wrong with the driveability or anything else unusual.

Confidential

REF. #10174068

ALLEG.	PHOTOGRAPH REQUIRED	INFORMATION	EVALUATION
C	Sudden Acceleration or Throttle Hold <input type="checkbox"/> Accelerator Pedal <input type="checkbox"/> Throttle Cable <input type="checkbox"/> Return Springs <input type="checkbox"/> Floor Mats	<input type="checkbox"/> Describe any Accelerator Pedal interference with Carpet/Mat _____ _____ _____ _____	<input type="checkbox"/> DRB II Tests <input type="checkbox"/> Disconnect Cable at Throttle Body/Carburetor lever; operate: <input type="checkbox"/> Lever <input type="checkbox"/> Cable <input type="checkbox"/> Any restricted motion? <input type="checkbox"/> Yes <input type="checkbox"/> No <input type="checkbox"/> If safe and permitted to drive - attempt to duplicate and check Service Brakes at reported speed.

D	Brakes <input type="checkbox"/> Items in Information Block.	<input type="checkbox"/> Check and record Brake Fluid Level. _____ <input type="checkbox"/> Check and record if Vacuum Hose is connected. <input type="checkbox"/> Yes <input type="checkbox"/> No <input type="checkbox"/> Check and record for Brake Line Leaks. <input type="checkbox"/> Yes <input type="checkbox"/> No <input type="checkbox"/> Pull Wheels, check Linings and record condition. <input type="checkbox"/> Check Brake Pedal, does it set firm? <input type="checkbox"/> Yes <input type="checkbox"/> No <input type="checkbox"/> Check operation of Parking Brake. <input type="checkbox"/> Check operation of ABS System.	With Engine off: <input type="checkbox"/> Apply Brake fully 3 or 4 times. <input type="checkbox"/> With light force held to Pedal, start the Engine. <input type="checkbox"/> Note reaction of Pedal and record: _____ _____ <input type="checkbox"/> ABS System DRB II test readouts _____ _____
----------	--	---	---

E	Steering <input type="checkbox"/> Complete Steering System Including as required: • Rack & Pinion • Linkage • CV & Universal Joints • Column • Belts & Pulleys	<input type="checkbox"/> Record if: <input type="checkbox"/> Manual Steering <input type="checkbox"/> Power Steering <input type="checkbox"/> Check Fluid Level _____ <input type="checkbox"/> Record if Drive Belt is tight <input type="checkbox"/> Yes <input type="checkbox"/> No <input type="checkbox"/> Check for Hose/System leaks <input type="checkbox"/> Yes <input type="checkbox"/> No Leaks <input type="checkbox"/> Check condition of Steering Linkage from Wheel to Steering Column, record deformation or loose connections. _____ _____	<input type="checkbox"/> Unlock key and turn Wheels fully right and left. <input type="checkbox"/> If safe, start Engine and turn Wheels fully right and left. <input type="checkbox"/> Record Steering function.
----------	--	---	---

F	Transmission <input type="checkbox"/> Entire Transmission with pictures and closeup of leaks, if any.	<input type="checkbox"/> Record: Type of Transmission? <input type="checkbox"/> Auto <input type="checkbox"/> Std. How many Speeds? <input type="checkbox"/> 3 <input type="checkbox"/> 4 <input type="checkbox"/> 5 <input type="checkbox"/> Record Gear Shift location at time of inspection _____ _____ <input type="checkbox"/> Run Shift Lever thru all shift positions and record "Feel of Gating" _____ _____ <input type="checkbox"/> Is Shift Indicator properly aligned? <input type="checkbox"/> Yes <input type="checkbox"/> No	If safe and permitted to drive vehicle: <input type="checkbox"/> Drive Vehicle and record feel of Gear during each Gear Shift. _____ _____ _____ <input type="checkbox"/> Does Parking Pawl engage? <input type="checkbox"/> Yes <input type="checkbox"/> No <input type="checkbox"/> If lockup is alleged - check rotation of Transmission in all Gears. <input type="checkbox"/> Check starting ability in park and neutral. Check to see that start does not occur in other selector positions.
----------	--	---	--

G	Engine Stall/ Drivability <input type="checkbox"/> Complete Engine Compartment Including as required: • Underhood Emissions Label • Engine Wiring/Connections • Vacuum Hoses • Fuel Lines • Exhaust System • Spark Plugs • Connections	<input type="checkbox"/> Record type of Spark Plugs (location of unique plugs). _____ _____ _____ _____ _____	If safe and permitted to: <input type="checkbox"/> Try to duplicate Allegation Off Hiway <input type="checkbox"/> DRB II or I/P Fault Code Test _____ _____ _____
----------	--	--	--

Confidential

REF. # 1017406

Exterior Damage Diagram and Measurements

No DAMAGE

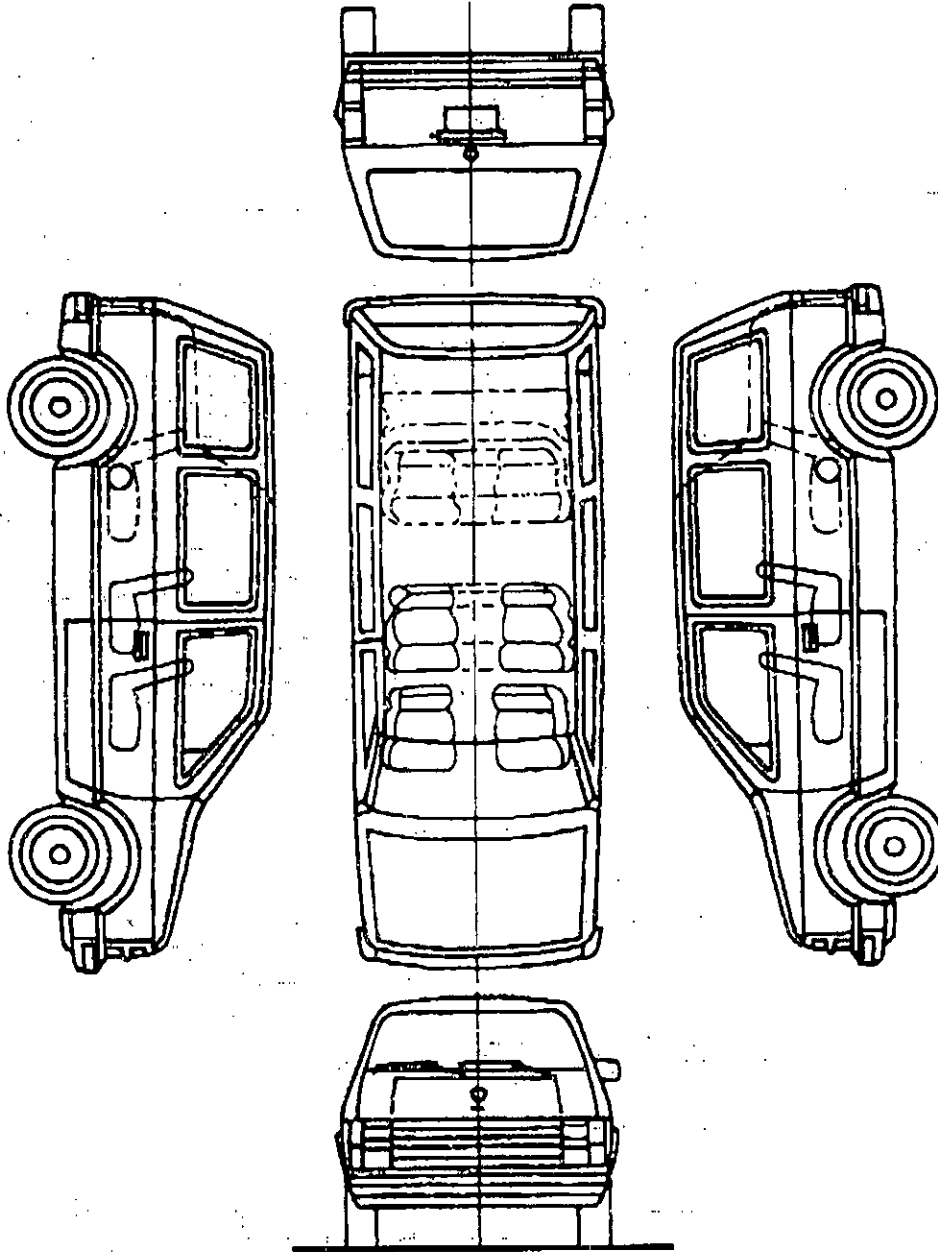

Sketch damage on all views. Include dimensions to describe and locate each damaged area and maximum depth of penetration for each impact. Annotate observations which might be useful in reconstructing the accident (e.g., direction of scrapes, markings on tires and wheels, etc.). Take photographs.

EA12-001

CHRYSLER

10-4-2012

ENCLOSURE 4

FIELD DATA SUBJECT

CAIRs Backup

Yahoo! Mail - [REDACTED]

Page 1 of 2

28638 Mot

Warren, Michigan 48

(588)

FAX (588):

Facsimile Cover Sheet

DaimlerChrysler Vehicle Investigation

Owner:



Project No. DAIM-0001 CAIR No.: 10447794

TO: Bud Nelson

FROM: Tina Martin

Date Sent: 9-17-02

DUE DATE: 9-20-02

FAX —
8 PAGES TOTAL

***PLEASE ACKNOWLEDGE PROMPTLY BY FAX OR EMAIL**

***Receipt of CAIR and Accepting case for investigation**
No

Date:

.../ShowLetter?box=Inbox&MsgId=7234_129986_3110_1083_28146_0_22933&bodyPa9/17/02

Yahoo! Mail - [REDACTED]

Coversheet for DaimlerChrysler (Service Associate Use Only)

(Also fax or email to EAA for closure)

***Closure Date: DaimlerChrysler Fax No.: 248- 512-8**

Bennis (248) 944-7036 Martell (248) 944-7038

Bott (248) 944-7056 Susalla (248) 944-7149

Arch **Gilbert (248) 944-7037 Porterfield (248) 944-7134**

Comments:

.../ShowLetter?box=Inbox&MsgID=7234_129986_3110_1083_26146_0_229338&bodyPa9/17/02

Yahoo! Mail -

Page 1 of 2

File name: 10447784.txt
File type: application/octet-stream

100/1702 CAIR Data File CAIR: 10447784 05 1/1 Page: 1

Company: Tmp Address:

Cust:

AD1:

AD2: Ph:

Cty/SI/ZIP: LARGO FL Crtry: USA Lang: E

Co-addr:

Company:

Rep:

AD1: Ph:

AD2: Ph:

Cty/SI/ZIP: Crtry: Lang:

Status and Notes -----|Check Information -----

Opened by: RCH8 Open Dt: 001702 Typ: L | Ck Amt: \$.00 E:

Stat: O Closed by: Closed Dt: | Payee:

Akt: A Cur/resp: ALG2 82 |

Let Upd: 001702 1020A ALG2 82 | Addr1:

Crnto Typ: T Orig: C Mail Orig: | Addr2:

Dt on Ltr: Exec: | City:

Resp Ltr: Resp Ltr Dt: | SI/ZIP:

Vehicle Information -----

VIN: 1J8GK88K02W205184 YR/Model: 02 JEEP LIBERTY LTD EDITION 4X2 SPORT UTILIT

Sls Zn/Sls Svc/Dir: 86 K K 82821 DAYTON ANDREWS INC In Srv Date: 11/16/01

Svc Zn/Sls Svc/Dir: 86 K K 82821 DAYTON ANDREWS INC Curr MIA/Km: M 8325

WCC: 338 - /36 3/36 0 7

.../ShowLetter?box=Inbox&MsgId=7234_129985_3110_1083_26146_0_22933&bodyPa9/17/02

Yahoo! Mail - [REDACTED]

CSC: HNRAT70P - 7/79 WARRANTY WRAPAROUND

Recall: A07 - AIR BAG WIRE CHAFING SAFETY Status: I

General Narrative

REASONS FOR CONTACT:

1) Air Bag Inquiry

*-> NARRATIVE ADDED BY R. C. HORN ON 09/17/02 AT 09:18AM

9/17/02 RCH6 owner was driving down the road and air bag light came on and air bag deployed without any impact. Owner has been put in a rental car and vehicle is # 82821. Charlie Flatley, Service Manager, has keys and knows of vehicle. Dealer phone 727-769-4439. Owner and DM request EAA inspection.

Please advise DM, Bob Horn 407-748-8787

NOTE: Recall A07 air bag wiring chafing has not been performed.

*-> NARRATIVE ADDED BY A. L. GILBERT ON 09/17/02 AT 10:21AM

82821 DAYTON ANDREWS INC CJ

2388 GULF TO BAY BOULEVA CLEARWATER FL 33765 727-769-4439

9-17-02 please contact owner and arrange for inspection on deployment of air bags. need d/e codes and times. check for hidden damage. Thanks.

art gilbert

CLAIM NUMBER 10447709 REQUEST EAA INSPECTION 09-17-2002 10:22

*mon - 9/16/02
7 AM?*

*no. clear.
Just turned corner 30-35 MPH.
Light f. help
came on - then both deployed.
Driver's head in gear by part -
Driver's head in stomach
brined -*

.../ShowLetter?box=Info&MsgID=7234_129986_3110_1083_26146_0_229338&bodyPa9/17/02

DAIMLERCHRYSLER

Confidential Preliminary Vehicle Investigation Report

REF. # 10447799

YEAR 2002	MODEL JEEP	VEHICLE IDENTIFICATION NUMBER 1J06K59M62W	SECURITY NUMBER 8325	M.I.H. 101023	DELIVERY DATE 11-6-01
CITY LARGO		STATE FL	ZIP 33770	BUSINESS PHONE	
SELLING DEALER NAME DAYTON ANDREAS		ZONE 66	DLR CODE 62621	CITY CLEARWATER	STATE FL
SALES REPRESENTATIVE C.L. (BUD) NELSON		PHONE 494-9517	ORLANDO		

INTERVIEW

INTERVIEW WITH <input checked="" type="checkbox"/> DRIVER <input checked="" type="checkbox"/> OWNER <input type="checkbox"/> OTHER	NAME MAS, KATHY GARTIN	INTERVIEW DATE 09/18/02	DATE OF INCIDENT 09/16/02	TIME OF INCIDENT 7:00	INSPECTION DATE 09/18/02
---	---------------------------	----------------------------	------------------------------	--------------------------	-----------------------------

DESCRIPTION OF EVENT (INCLUDING WEATHER CONDITIONS AND ROAD SURFACE)
CLEAR

Driver's and/or occupant's description of incident
 What? When? Where? How?
 Exact order of events
 Did this happen before?

JUST TURNED CORNER, AT 35MPH, AIRBAG LIGHT CAME ON, BELL DINGED AND ONE MINUTE LATER BOTH AIRBAGS DEPLOYED. PASS. HIT IN JAW BY DEBRIS, DRIVER'S STOMACH BRUISED BY BAG.

Personal Injury: Were there Personal Injuries? Yes No If yes, complete section "L."

IMPORTANT: SHOW TO NO ONE & DRAW NO CONCLUSIONS

- DIRECTIONS:
- FILL OUT UPPER PART OF FORM.
 - FOR "FIRE" USE FORM 84-130-8950.
 - FOLLOW INSTRUCTIONS FOR SECTION "A" ON ALL VEHICLES.
 - FOLLOW INSTRUCTIONS FOR SPECIFIC ALLEGATIONS FOR THIS VEHICLE.
 - ATTACH ANY ADDENDUMS TO REPORT AND STATE SECTION IT PERTAINS TO.

- COMMENTS:
- NOTE ANY MISSING COMPONENTS AND WHO REMOVED THEM.
 - NOTE ANY AFTERMARKET EQUIPMENT INSTALLED AND BY WHOM.

ALLEG.	PHOTOGRAPH REQUIRED	INFORMATION	EVALUATION
A	<input type="checkbox"/> Front center of vehicle front every 45 degrees (8 total) <input type="checkbox"/> If crush damaged - perspective front every corner of vehicle down both original lateral sight lines (8 total)	<input type="checkbox"/> Police report <input type="checkbox"/> Vehicle service file <input type="checkbox"/> Any reports/photos by others <input type="checkbox"/> Location of inspection	<input type="checkbox"/> Driver's and/or occupant's description of incident <input type="checkbox"/> Complete exterior damage diagram and measurements on last page. <input type="checkbox"/> What? When? Where? How? <input type="checkbox"/> Exact order of events <input type="checkbox"/> Did this happen before?

B	<input checked="" type="checkbox"/> Steering Wheel <input checked="" type="checkbox"/> Airbag(s) <input type="checkbox"/> Knee Blockers <input type="checkbox"/> All visible body contact areas <input checked="" type="checkbox"/> All code readings using DRB II	<input checked="" type="checkbox"/> Record: <input type="checkbox"/> Was Airbag deployed? Driver <input checked="" type="checkbox"/> Yes <input type="checkbox"/> No Passenger <input type="checkbox"/> Yes <input type="checkbox"/> No <input type="checkbox"/> Type of Steering Wheel <input checked="" type="checkbox"/> TIR <input type="checkbox"/> Std. <input type="checkbox"/> Condition of Steering Wheel UNDAMAGED <input type="checkbox"/> Condition of Steering Wheel Mounting (measure column collapse) UNDAMAGED	<input type="checkbox"/> Evidence of tampering or disassembly? <input type="checkbox"/> Yes <input checked="" type="checkbox"/> No <input type="checkbox"/> Use DRB II <input type="checkbox"/> Record Existing Readings 1. NO READINGS - COULD NOT ACCESS AIRBAG CODES - ENGINE 2. ALL OTHERS CAN BE READ BUT NOTHING ON AIRBAGS. <input type="checkbox"/> Record Stored Readings 1. _____ 2. _____ 3. _____ <input type="checkbox"/> Important: DO NOT ERASE DRB II READINGS.
----------	--	---	---

Confidential

REF # 1044779

ALLEG. PHOTOGRAPH REQUIRED INFORMATION EVALUATION

Sudden Acceleration or Throttle Hold

C

- Accelerator Pedal
 - Throttle Cable
 - Return Springs
 - Floor Mats
- Describe any Accelerator Pedal Interference with Carpet/Mat
- _____
- _____
- _____
- _____

- DRB II Tests
- Disconnect Cable at Throttle Body/Carburetor lever; operate:
 - Lever
 - Cable
- Any restricted motion?
 - Yes
 - No
- If safe and permitted to drive - attempt to duplicate and check Service Brakes at reported speed.

Brakes

D

- Items in Information Block.
- Check and record Brake Fluid Level. _____
- Check and record if Vacuum Hose is connected: Yes No
- Check and record for Brake Line Leaks. Yes No
- Pull Wheels, check Linings and record condition.
- Check Brake Pedal, does it set firm? Yes No
- Check operation of Parking Brake.
- Check operation of ABS System.

- With Engine off:
- Apply Brake fully 3 or 4 times.
- With light force hold to Pedal, start the Engine.
- Note reaction of Pedal and record: _____
- ABS System DRB II test readouts _____

Steering

E

- Complete Steering System including as required:
 - Rack & Pinion
 - Linkage
 - CV & Universal Joints
 - Column
 - Belts & Pulleys
 - Record it:
 - Manual Steering
 - Power Steering
 - Check Fluid Level _____
 - Record if Drive Belt is tight Yes No
 - Check for Hose/System leaks Yes No Leaks
 - Check condition of Steering Linkage from Wheels to Steering Column, record deformation or loose connections.
- _____
- _____

- Unlock key and turn Wheels fully right and left.
- If safe, start Engine and turn Wheels fully right and left.
- Record Steering function.

Transmission

F

- Entire Transmission with pictures and closeup of leaks, if any.
- Record:
 - Type of Transmission?
 - Auto
 - Std.
 - How many Speeds?
 - 3
 - 4
 - 5
- Record Gear Shift location at time of inspection _____
- Run Shift Lever thru all shift positions and record "Feel of Gating" _____
- Is Shift Indicator properly aligned?
 - Yes
 - No

- If safe and permitted to drive vehicle:
- Drive Vehicle and record feet of Gear during each Gear Shift _____
- Does Parking Pawl engage?
 - Yes
 - No
- If lockup is alleged - check rotation of Transmission in all Gears.
- Check starting ability in park and neutral. Check to see that start does not occur in other selector positions.

Engine Stall/ Drivability

G

- Complete Engine Compartment including as required:
 - Underhood Emissions Label
 - Engine Wiring/Connections
 - Vacuum Hoses
 - Fuel Lines
 - Exhaust System
 - Spark Plugs
 - Connectors
- Record type of Spark Plugs (location of unique plugs). _____
- _____
- _____
- _____
- _____
- _____

- If safe and permitted to:
- Try to duplicate Allegation Off Highway
- DRB II or I/P Fault Code Test _____
- _____
- _____
- _____

Confidential

REF # 10447794

ALLEG.	PHOTOGRAPH REQUIRED	INFORMATION	EVALUATION
H Seat/Shoulder Belts	<input type="checkbox"/> Overall of seat belts I/B and O/B. <input type="checkbox"/> Close ups of any irregularities on belts. <input type="checkbox"/> Shoulder Belt Pendulum <input type="checkbox"/> Latchplate wear <input type="checkbox"/> Close up of D-ring to show belt loading.	<input type="checkbox"/> Locate seat belt labels and record ALL information (Some labels are sewn to webbing, other labels are on retractor frame. Inboard seat belt labels are near floor.) <input type="checkbox"/> Record ALL information stamped on latchplate.	If allowed, function belts to insure they FUNCTION PROPERLY; note results: Do they latch? <input type="checkbox"/> Yes <input type="checkbox"/> No Do they release? <input type="checkbox"/> Yes <input type="checkbox"/> No Do they retract? <input type="checkbox"/> Yes <input type="checkbox"/> No <input type="checkbox"/> Does Inertia Pendulum System run freely? <input type="checkbox"/> Yes <input type="checkbox"/> No

I Seat	<input type="checkbox"/> Overall of seat <input type="checkbox"/> Close ups of damage	<input type="checkbox"/> Existing location of recliner - number of teeth from rear of sector gear to rear edge of Pawl (crayon mark location). <input type="checkbox"/> Existing location of seat adjuster (window or tooth location from rear of adjuster). <input type="checkbox"/> Existing location of head restraint (measure gap under head restraint).	<input type="checkbox"/> If allowed, adjust all functions of seat and return to original location <input type="checkbox"/> Describe functions <input type="checkbox"/> Note any irregular orientations

J Tires	<input type="checkbox"/> Each Tire with visible location label, insuring all Tire Identification and Tread wear is documented. <input type="checkbox"/> All damaged Wheel and Rim area including impacted foreign material.	Record: <input type="checkbox"/> Tire Size <input type="checkbox"/> Brand <input type="checkbox"/> Ratings <input type="checkbox"/> DOT No. (I/B Side) <input type="checkbox"/> Rim Size <input type="checkbox"/> Tread Depth	Front Left	Front Right	Rear Left	Rear Right

K Axle Lookup	<input type="checkbox"/> Entire Axle and close up of Leaks	<input type="checkbox"/> While on hoist: <input type="checkbox"/> Rear Wheel Drive Record amount of Lateral Axle Movement on each side and will Wheels turn
		<input type="checkbox"/> Trans. Axle - rotate Wheels <input type="checkbox"/> Note function

L Occupant Contact	<input type="checkbox"/> Windshield <input type="checkbox"/> All areas of occupant contact on interior and exterior. <input type="checkbox"/> Close ups of stains, skin, hair, cloth <input type="checkbox"/> Exterior and Interior damage	<input type="checkbox"/> See Seat Belts/Seats if applicable <input type="checkbox"/> Occupant contact description

ADDITIONAL COMMENTS

THE SCANNER MESSAGE REGARDING AIRBAGS SAYS TO THE EFFECT, "SOFTWARE NOT CORRECT TO SECURE THE INFO. DESIRED."

Confidential

REF. # ~~10447894~~

Exterior Damage Diagram and Measurements

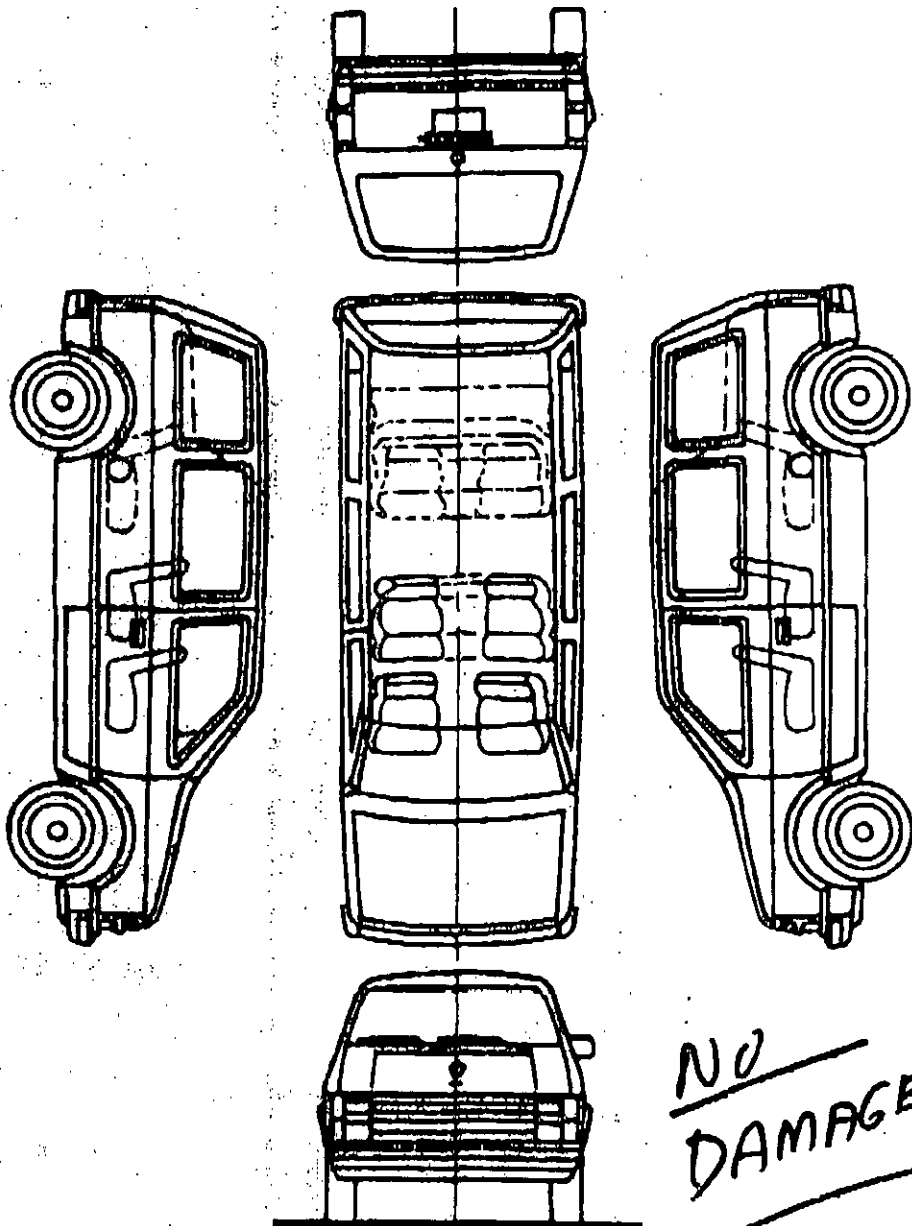

NO
DAMAGE

Sketch damage on all views. Include dimensions to describe and locate each damaged area and maximum depth of penetration for each impact. Annotate observations which might be useful in reconstructing the accident (e.g., direction of scrapes, markings on tires and wheels, etc.). Take photographs.

EA12-001

CHRYSLER

10-4-2012

ENCLOSURE 4

FIELD DATA SUBJECT

CAIRs Backup



01/21/2003

CONTROLLED SUBSTANCE

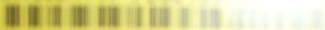

WARNING: DO NOT RE-SCREW BATTERY. DO NOT REWELD.
IMPROPER SCREWING CAN RESULT IN AIR BAG SYSTEM
FAILURE AND POSSIBLE DEATH AND/OR PERSONAL INJURY.

CONTROLLED SUBSTANCE TOP FUEL CYLINDER 1193 SUPPLIER CODE



01/21/2003



01/21/2003



MDS2

DELL

MDS2

01/21/2003



01/21/2003



01/21/2003



01/21/2003



01/21/2003



01/21/2003



01/21/2003



01/21/2003



01/21/2003



01/21/2008



Classifieds 427, 8208

Our FREE Classifieds Are Purrfect.

Republic's "Caraway" charges 10 FREE advertising for persons placing their resumes in our newspaper. To be eligible, resumes must be placed in the newspaper by 10:00 AM on the day of publication. To place your classified ad call (707) 432-8936. Monday - Friday, 9:00 AM - 5:00 PM.

Daily Republic • www.dailyrep.com

Confidential Authority

CONFIDENTIAL - Prior Approval

Primary Vehicle Investigator #

NAME	DATE	TIME	LOCATION	STATUS
...

SALES - L

INTERVIEW WITH: NAME LAST, FIRST, MIDDLE

INTERVIEW DATE: 11-21-03

1. DRIVER'S DESCRIPTION OF EVENT:

Insurance Company Name: USA

Personal Injury: Yes No

Were there personal injuries? Yes No

Any Indicator/Warning Lights on Prior? Yes No

IMPORTANT: SHO

Mila Pfeifer

air bag def.

airbag carriage

seat belts

01/21/2003

Nacerville 1-2203



Confidential Air

CONFIDENTIAL - Prior Approval

Preliminary Vehicle Investigation

Report #

IDENTIFICATION NUMBER

PLATE #

ALVIN

DATE

REPORTING OFFICE



SALES - LE

DATE:

1-23

DRIVER'S DESCRIPTION OF EVENT:

Insurance Company Name:
Personal Injury:
Were there Personal Injuries?
Any bodily damage?
Weather conditions?

Alpa
maye
01/21/2003

Help Key

PART A - GENERAL

Chrysler



01/21/2003



01/21/2003



01/21/2003



01/21/2003



01/21/2003



01/21/2003



01/21/2003

WARNING



**DEATH OR SERIOUS
INJURY CAN OCCUR**

- CHILDREN 12 AND UNDER CAN BE KILLED BY THE AIR BAG.
- THE BACK SEAT IS THE SAFEST PLACE FOR CHILDREN.
- NEVER PUT A REAR-FACING CHILD SEAT IN THE FRONT.
- SIT AS FAR BACK AS POSSIBLE FROM THE AIR BAG.
- ALWAYS USE SEAT BELTS AND CHILD RESTRAINTS.

AWA



01/21/2003



01/21/2003

STY CARING
449-8900

01/21/2003



Jeep
LIBERTY

3.7L

01/21/2003



01/21/2003



01/21/2003



01/21/2003



01/21/2003



01/21/2003



01/21/2003

⚠ WARNING

DEATH OR SERIOUS INJURY CAN OCCUR



- CHILDREN 12 AND UNDER CAN BE KILLED BY THE AIR BAG.
- THE BACK SEAT IS THE SAFEST PLACE FOR CHILDREN.
- NEVER PUT A REAR-FACING CHILD SEAT IN THE FRONT.
- SIT AS FAR BACK AS POSSIBLE FROM THE AIR BAG.
- ALWAYS USE SEAT BELTS AND CHILD RESTRAINTS.

01/21/2003

MFD BY DAIMLERCHRYSLER CORPORATION DATE OF MFR 3-02 GVWR 2541 KG (85600 LB)

GVWR FRONT	WITH TIRES	RIMS AT	COLD
1180 KG (2600 LB)	235/70R16	16X7	227 KPA(33 PSI)
GVWR REAR	WITH TIRES	RIMS AT	COLD
1429 KG (3150 LB)	235/70R16	16X7	227 KPA(33 PSI)

THIS VEHICLE CONFORMS TO ALL APPLICABLE FEDERAL MOTOR VEHICLE SAFETY AND THEFT PREVENTION STANDARDS IN EFFECT ON THE DATE OF MANUFACTURE SHOWN ABOVE.

VIN: 1J8GL5BK32 [REDACTED] TYPE: MPV SINGLE X DUAL



MDH: 831521 387AA PNT:PS2 VEHICLE MADE IN U.S.A. TRN:DL2 4648583

01/21/2003



01/21/2003



01/21/2003



01/21/2003



01/21/2003



01/21/2003



01/21/2003



01/21/2003



1/21/2003



110007
5210112038
10835-D

01/21/2003



01/21/2003



01/21/2003



01/21/2003



01/21/2003

- Main Menu
1. DRB III Standalone
 2. Connect to MDS2
 3. Generic Scan Tool
 4. PEP Module Tools
 5. Run Memory Card Program
 6. DRB Utilities
 7. Vehicle Flash
 8. Legacy MDS1 Support

Page 1 of 1

HELP

CONFIDENTIAL - Private Information

CASE#	00000000	00000000
NAME	STRANGLER 4VA	1997
YEAR	1997	1997
MAKE	CHRYSLER	1997
MODEL	PT CRUISER	1997
VIN	1C3B3C9G9L7000000	1997
YEAR	1997	1997
MAKE	Chrysler	1997
MODEL	PT CRUISER	1997
YEAR	1997	1997
SELLING DEALER	JACK MILLER TOYS	
INSPECTOR	NAME LAST	
DAMAGE	MODERATE	
HONOR	MODERATE	

01/21/2003



SELECT SYSTEM

- 1. Engine
- 2. Transmission
- 3. Body
- 4. Chassis
- 5. Anti-lock Brakes
- 6. Passive Restraints
- 7. Theft Alarm
- 8. System Monitors

Page 1 of 1

HELP SYS MAIN



F1 F2 F3 F4

ENTER

01/21/2003

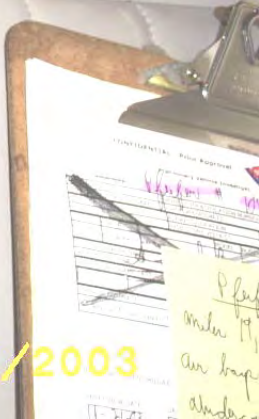

CONFIDENTIAL - Your Approval

DATE: 1/21/03

TIME: 11:00

BY: [Signature]

Please
 under 19
 our bags
 always

SELECT RESTRAINT SYSTEM
1. Airbag
2. Side Airbags
3. Airbag On/OFF Switch System

Page 1 of 1

HELP SYS MAIN

CONFIDENTIAL - Prior Approval

Interview with: *Blakely*

NAME	
DOB	
SSN	
PHONE	
ADDRESS	
CITY	
STATE	
ZIP	
DATE OF INTERVIEW	
INTERVIEWER	
INTERVIEWER TITLE	
INTERVIEW DATE	
INTERVIEW TIME	
INTERVIEW LOCATION	
INTERVIEW METHOD	
INTERVIEWER SIGNATURE	
INTERVIEWEE SIGNATURE	
INTERVIEWEE TITLE	
INTERVIEWEE AGENCY	
INTERVIEWEE CONTACT	
INTERVIEWEE PHONE	
INTERVIEWEE FAX	
INTERVIEWEE EMAIL	
INTERVIEWEE WEBSITE	
INTERVIEWEE ADDRESS	
INTERVIEWEE CITY	
INTERVIEWEE STATE	
INTERVIEWEE ZIP	
INTERVIEWEE COUNTY	
INTERVIEWEE DISTRICT	
INTERVIEWEE OFFICE	
INTERVIEWEE DIVISION	
INTERVIEWEE BRANCH	
INTERVIEWEE SECTION	
INTERVIEWEE UNIT	
INTERVIEWEE POSITION	
INTERVIEWEE GRADE	
INTERVIEWEE PAY RATE	
INTERVIEWEE EMPLOYMENT TYPE	
INTERVIEWEE STATUS	
INTERVIEWEE CLASSIFICATION	
INTERVIEWEE CODE	
INTERVIEWEE ID	
INTERVIEWEE PHOTO	
INTERVIEWEE SIGNATURE	
INTERVIEWEE TITLE	
INTERVIEWEE AGENCY	
INTERVIEWEE CONTACT	
INTERVIEWEE PHONE	
INTERVIEWEE FAX	
INTERVIEWEE EMAIL	
INTERVIEWEE WEBSITE	
INTERVIEWEE ADDRESS	
INTERVIEWEE CITY	
INTERVIEWEE STATE	
INTERVIEWEE ZIP	
INTERVIEWEE COUNTY	
INTERVIEWEE DISTRICT	
INTERVIEWEE OFFICE	
INTERVIEWEE DIVISION	
INTERVIEWEE BRANCH	
INTERVIEWEE SECTION	
INTERVIEWEE UNIT	
INTERVIEWEE POSITION	
INTERVIEWEE GRADE	
INTERVIEWEE PAY RATE	
INTERVIEWEE EMPLOYMENT TYPE	
INTERVIEWEE STATUS	
INTERVIEWEE CLASSIFICATION	
INTERVIEWEE CODE	
INTERVIEWEE ID	
INTERVIEWEE PHOTO	

INTERVIEW WITH: *Blakely*

INTERVIEW DATE: 11-24-03

INTERVIEW TIME: 11:24:03

INTERVIEW LOCATION: *Blakely*

INTERVIEW METHOD: *Blakely*

INTERVIEWER: *Blakely*

INTERVIEWER TITLE: *Blakely*

INTERVIEWER AGENCY: *Blakely*

INTERVIEWER CONTACT: *Blakely*

INTERVIEWER PHONE: *Blakely*

INTERVIEWER FAX: *Blakely*

INTERVIEWER EMAIL: *Blakely*

INTERVIEWER WEBSITE: *Blakely*

INTERVIEWER ADDRESS: *Blakely*

INTERVIEWER CITY: *Blakely*

INTERVIEWER STATE: *Blakely*

INTERVIEWER ZIP: *Blakely*

INTERVIEWER COUNTY: *Blakely*

INTERVIEWER DISTRICT: *Blakely*

INTERVIEWER OFFICE: *Blakely*

INTERVIEWER DIVISION: *Blakely*

INTERVIEWER BRANCH: *Blakely*

INTERVIEWER SECTION: *Blakely*

INTERVIEWER UNIT: *Blakely*

INTERVIEWER POSITION: *Blakely*

INTERVIEWER GRADE: *Blakely*

INTERVIEWER PAY RATE: *Blakely*

INTERVIEWER EMPLOYMENT TYPE: *Blakely*

INTERVIEWER STATUS: *Blakely*

INTERVIEWER CLASSIFICATION: *Blakely*

INTERVIEWER CODE: *Blakely*

INTERVIEWER ID: *Blakely*

INTERVIEWER PHOTO: *Blakely*

01/21/2003

This Diagnostic Control
Module is not supported by
this software. Please use the
DRB III with the Supercard
software to diagnose this
vehicle.

F1

SYS

MAIN

F1

F2

F3

F4

ENTER

↑

↓

01/21/2003

Disable IO Module for
OSC

press any key to continue

F1 F2 F3 F4



01/21/2003

CONFIDENTIAL - Your Review

Primary Office Location

London, VA

Secondary Office Location

London, VA

Office Name

London, VA

Office Address

London, VA

Office Phone

London, VA

Office Fax

London, VA

*Plat
m...*



01/21/2003



01/21/2003

01/21/2003



12:11

REVERSE
STOP

01/21/2003



01/21/2003



01/21/2003

SRS
AIRBAG

01/21/2003

SRS
AIRBAG

01/21/2003



01/21/2003



01/21/2003



01/21/2003



707 449-8900

671 ORANGE DR. • VACAVILLE, CA 95687

FAX TRANSMISSION

To:

NAME <i>PORTERFIELD</i>	DATE AND TIME OF TRANSMISSION <i>March 4, 2003</i>
COMPLAINT <i>DANNON CHRYS SPECIAL INVESTIGATIONS</i>	FAX NUMBER <i>248-512-8748</i>

From:

NAME <i>DAVID LAW - 707-452-2546</i>	FAX NUMBER <i>(707) 452-7332</i>
---	-------------------------------------

Reference:

SUBJECT <i>DIRECT CHECK RENTAL REIMB.</i>
--

Message:

42 day rental for [REDACTED]

Coin # 10850016

TOTAL RENTAL \$ 1,172.54

(PLEASE REFERENCE RD 135056.)

THANKS -

D. LAW

NOV 10 08855

NO CHARGE

ORIGIN VEHICLE
 RENTAL NO. 40FT 141
 LICENSE NO. 216 25
 LOCAL ADDRESS RAIRFIELD CA
 DRIVER'S LICENSE 88420707 CA 3/16/03
 SOCIAL SECURITY 216 75
 EMPLOYER

DAY = 24 HOUR PERIOD
 HOURS #
 42 10.00 HOUR
 25.00 DAY
 25.00++ 1082.00

BILL TO COMPANY
 ADDRESS DODGE/PLYMOUTH OF VACAVILLE**
 471 ORANGE DR
 CITY VACAVILLE CA 95687
 PHONE 707-449-8900
 RENTER ACCEPTS LIABILITY RESPONSIBILITY X
 RENTERS DECLINES LIABILITY RESPONSIBILITY X
 ADDITIONAL AUTHORIZED DRIVER - NONE PERMITTED WITHOUT OWNER'S APPROVAL

CCX
 ON 14.99/DAY
 BAI 3.00/DAY
 SLP 9.99/DAY
 TAX 7.375 80.34
 FUEL CHARGE 2.75/DOLLAR

PERMISSION GRANTED FOR VEHICLE TO LEAVE THE STATE OF RENTAL
 YES NO
 AUTHORIZED STATES OF OPERATION CA ONLY
 AUTH BY OWNER'S REP

TOTAL CHARGES 1172.54

ACKNOWLEDGMENT OF THE ENTIRE AGREEMENT INCLUDING RENTAL AGREEMENT, TICKET JACKET
 I HAVE READ AND AGREE TO THE TERMS AND CONDITIONS ON BOTH SIDES OF THIS PAGE AND THE ATTACHED RENTAL AGREEMENT, TICKET JACKET WHICH IS HEREBY INCORPORATED IN AND A PART OF THIS AGREEMENT. MY SIGNATURE BELOW IS CONSIDERED TO HAVE BEEN MADE ON ANY APPLICABLE CREDIT CARD VOUCHER AND I AUTHORIZE OWNER TO REFUSE OR LIMIT MY LIABILITY RESTRICTIONS.

DEPOSITS
 REFUNDS
 AMOUNT DUE 1172.54
 CLOSED BY

REPLACE/RENTAL VEHICLE
 RETURN CAR BY EXT TO
 DATE 1/16/03
 DEPT
 ADDTL DEP
 ADDTL DEP
 ADDTL DEP

PAID BY CASH
 RECEIPT FOR CASH REFUND
 DATE RECEIVED
 AMOUNT

ADDITIONAL INFORMATION
 DROPPED VEHICLES: If Renter returns vehicle during non-business hours at any place other than the original rental branch, Renter agrees to pay for any and all damages and/or rental charges incurred and to be assessed to the vehicle.
 8518 8509
 PRINCEVILLE

CLAIM INFORMATION
 POL OR CL# 31924
 INSUR
 LOSS DATE
 PHONE 707-449-8900
 REPAIR SHOP DODGE/PLYMOUTH DE
 LIBERTY



28635 Mound Road
Warren, Michigan 48092-3499
(586) 753-3326
FAX (586) 753-3335

Facsimile Cover Sheet
DaimlerChrysler Vehicle Investigation

Owner: [REDACTED]

Project No. DAIM-2003

CAIR No.: 10850016

TO: Bob Lewis

FROM: Tina Martin

Date Sent: 01-21-03

DUE DATE: 01-24-03

***PLEASE ACKNOWLEDGE PROMPTLY BY FAX OR EMAIL**

***Receipt of CAIR and Accepting case for investigation?** Yes No

Date: 1-21-03

Coversheet for DaimlerChrysler (Service Associate Use Only)
(Also fax or email to EAA for closure)

*Closure Date: 1-22-03

DaimlerChrysler Fax No.: 248-512-8748

Bennis (248) 944-7036

Martell (248) 944-7038

Bott (248) 944-7056

Susalla (248) 944-7149

Gilbert (248) 944-7037

Porterfield (248) 944-7134

Comments: ATTACHMENTS: VACAVILLE D-C-J REPAIR
ORDERS (2).
Regard
Bob Lewis.



891 Orange Drive
Vacaville, CA 95687
(707) 449-8900
EPA# CAL000224187
BAR# AD183427

671 Orange Drive
Vacaville, CA 95687
(707) 452-7300
EPA# CAL000148576
BAR# AD216027

CAIR # 10850016

CUSTOMER NO. 36578	ACM# ORP AMY C PEARCE 428	TAG NO. 1503	INVOICE DATE 01/22/03	INVOICE NO. CHCS13: 82
FAIRFIELD, CA	LABOR RATE	LICENSE NO.	MILEAGE 16,181	COLOR SILVER/
	YEAR / MAKE / MODEL 02/JEEP/LIBERTY/UT LIBERTY LMTD	DELIVERY DATE 04/21/02	DELIVERY MILES 8	
	VEHICLE I.D. NO. 1J8GL58K32W	SELLING DEALER NO. 1	PRODUCTION DATE	
	F.T.E. NO.	P.O. NO.	01/22/03	
COMMENTS				MO: 16 81

LABOR & PARTS: ELECTRICAL SYSTEM TECH# 3000 144.00
 PER CHRYSLER INSPECTOR: INSPECT AND DIAGNOSE AIR BAG CONTROL MODULE COMMUNICATION
 PER CHRYSLER INSPECTOR: DRB UNABLE TO IDENTIFY OR COMMUNICATE WITH ACM. CODE SET IN INSTRUMENT CLUSTER FOR NO ORC BUS MESSAGE RECEIVED. TEST PER DIAG MANUAL (BODY DTAG PROCEDURE) PAGE 249. THAT PAGE INSTRUCTED TO USE COMMUNICATION DIAG PAGE 174. NO RESPONSE FROM ACM. BOTH POWER SUPPLIES AND GROUND OK AT ACM AND PCT BUS WERE OK. MODULE HAS BURNT SMELL. MODULE NEEDS TO BE REPLACED PER DTAG MANUAL.

JOB # 1 TOTAL LABOR & PARTS 144.00

ESTIMATE: CUSTOMER HEREBY ACKNOWLEDGES RECEIVING ORIGINAL ESTIMATE OF \$144.00 (+TAX)

COMMENTS: PARTS ETA 01/17 AIR BAGS, GLOCK SPRING AND BRACKET

TOTALS:

***** NEXT RECOMMENDED SERVICE 03/12/2003 / 19181 MI *****

WE HERE AT DODGE CHRYSLER JEEP OF VACAVILLE AND NISSAN OF VACAVILLE LOOK FORWARD TO PROVIDING YOU AND YOUR VEHICLE WITH CONTINUOUS QUALITY SERVICE.

PLEASE REMEMBER OUR SERVICE HOURS: FROM 7:30 AM TO 6:00 PM MONDAY THROUGH FRIDAY

PLEASE INITIAL HERE IF WE EXPLAINED THE REPAIRS/CHARGES

TOTAL LABOR	144.00
TOTAL PARTS	0.00
TOTAL SUBLET	0.00
TOTAL B.O.B.	0.00
TOTAL MISC. CHG.	0.00
TOTAL MISC. DISC.	0.00
TOTAL TAX	0.00

TOTAL INVOICE \$ 144.00

RECORD NUMBER: 887
 ACCOUNT: 441157613917674 88794
 NAME TYPE: 9168
 INTR TYPE: SALE
 CITY CODE: 622484

RECEIVED BY: 68624283
 DATE: 01/22/03 11:46:04 AM

SPRUE CHRYSLER
 671 ORANGE DR
 VACAVILLE, CA 95687-3193
 707-449-8900

175582

LEWIS, ROBERT E
 I AGREE TO PAY ABOVE TOTAL AMOUNT ACCORDING TO HONO TROUSEL AGREEMENT
 ACTION COPY CUSTOMER TOP COPY MERCHANT MERCHANT COPY

A I D
 JAN 22 2003
 CHECK VISA DISC

MO: 16 81
 BAR# AD216027



681 Orange Drive
Vacaville, CA 95687
(707) 449-8900
EPA# CAL000224187
BAR# AD163427



571 Orange Drive
Vacaville, CA 95687
(707) 452-7300
EPA# CAL000148576
BAR# AD216027

135056

135056

RECOMMENDED SERVICES

OPERATION	OPERATION DESCRIPTION	MO/MI	TOTAL	OPERATION	OPERATION DESCRIPTION	MO/MI	TOT
26CHZ-LOF	LUBE OIL AND FILTER	MI	0.00				

SERVICE HISTORY

DATE	REPAIR ORDER	MILEAGE	ADVISOR	TECHNICIAN	TYPE	OPERATION	OPERATION DESCRIPTION
12/19/02	133656	14177	428	620	W	26CHZ-15KG	15000 MILES SERVICE
09/20/02	127896	8859	428	632	W	26CHZ-6KG	6000 MILES SERVICE
06/06/02	120784	3191	461	197	W	26CHZ-LOF	LUBE OIL AND FILTER
03/28/02	116224	1	429	415	I	40CHZ-PDI	NEW VEHICLE PDI

SALESPERSON NO. 477

S E R V I C E

STATE REG# AD216027

SAVE OLD PARTS? <input type="checkbox"/> YES <input type="checkbox"/> NO	VEHICLE I.D. NO. 1J8GL58K32W	YEAR/MAKE/MODEL 02/JEEP/LIBERTY/UT LIBERTY LMTD	PRODUCTION DATE	STOCK NO. 16156	LICENSE NO. 135056
			DELIVERY DATE 04/21/02	DELIVERY MILES 181	SELLING DEALER NO. 0174
			CUSTOMER NO. 36578	CONTRACT NO.	EXPIRATION DATE
			COLOR SILVER/	EXPIRATION MILES	TAG NO. 1513
			TURBO CHZZ	MILEAGE 16,181	ADVISOR NO. 428
					ADVISOR AMY C PEARCE

I hereby authorize the repair work described for my vehicle to be done along with the necessary material and agree that you are not responsible for damage to vehicle or articles left in vehicle in case of fire, theft or any other cause beyond your control or for any delays caused by unavailability of parts or delays to parts shipment by the supplier or transporter. I hereby grant you and/or your employees permission to operate the herein described devices, hardware or software for the purpose of testing and/or inspection. An excess machine's lien is acknowledged on above vehicle to secure the amount of repair charges. I am responsible for the cargo from freezing due to lack of anti-freeze.

APPOINTMENT: Yes No

TIME RECEIVED: 02:19pm DATE TIME PROMISED: 01/15/03 06:00pm PRIORITY: 5

AUTHORIZED BY: [Signature]

TOTAL: [Redacted]

COMMENTS: BEING TOWED IN - SEE AMY

1. W: 21CHZ TRANS AUTO/MANU. CUSTOMER SAYS WHEN DRIVING 25-35 MPH VEHICLE HAS A CONTINUOUS HESITATION UNTIL ACCELERATES TO A STEADY SPEED. NO WARNING LIGHTS HAVE CAME ON. CHECK AND ADVISE.

2. W: 08CHZ ELECTRICAL SYSTEM. CUSTOMER WAS DRIVING, HEARD A CHIME DING, LOOKED DOWN AND BOTH DRIVER AND PASSENGER SIDE AIR BAGS DEPLOYED. TOWED IN, NO VISIBLE SIGNS OF IMPACT ON VEHICLE. CHECK AND ADVISE.

REVISED ESTIMATE DATE: [Redacted]

REVISED PARTS ORDERED: [Redacted]

REVISED ESTIMATE (\$): [Redacted]

TIME Date: [Redacted]

PERSON CONTACTED: [Redacted]

PHONE BY: [Redacted]

I HEREBY ACKNOWLEDGE THAT I WAS NOTIFIED & GAVE ORAL APPROVAL OF THE ABOVE REVISED ESTIMATES.

CUSTOMER SIGNATURE: [Redacted]

NOTES: BAR# AD216027

Also Rec'd 1/11/03 - 3800

1/17/03 - Rec'd - will contact speed

557 AM

Inventory returns and input care.

advised 1/17/03 @ 4:05

to Steven Pfeifer per

is discontinued as of

(he called in)

PSHG-331LEAF

Steven
688 7643
OR 424 6489

Brandi
688 9595

Fairfield, CA

facsimile transmittal

To: Mr. Potterfield

Fax:

From:

Date: 03/12/03

Re: Claim #10850016

Pages: 2

CC:

Urgent

For Review

Please Comment

Please Reply

Please Recycle

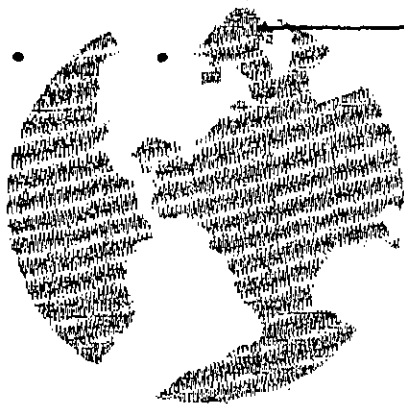

[Faded, illegible text at the bottom of the page]

March 12, 2003

Mr. Porterfield:

In regards to our conversation on Tuesday, February 18, 2003 regarding my claim file #10850016.

In response to your request I have reached a fair and reasonable sum of \$63,363.70. The breakdown is as follows:

-	Lost wages (Nine days following incident)	\$ 1,713.70
-	Lost wages (to date after returning to work)	600.00
-	Medication	40.00
-	Car payments (2 months)	1,010.00
-	Mental Anguish	15,000.00
-	Pain and suffering to back, neck, and left arm	25,000.00
-	Release of any future claim due to Lost wages, medical, medication, etc.	25,000.00
	Total	\$63,363.70

Upon your review and agreement of this request, I release all future liability caused by the malfunction of my 2002 Jeep air bag unit.

Please contact me within 3-5 business days from today by phone or by certified check at the phone number or address below.

Thanks again for your immediate assistance in this matter.

Sincerely,

[Redacted Signature]

Fairfield, CA

[Redacted Address]

cairnumber :10850016

CONFIDENTIAL - Prior Approval Required Before Duplicating

Preliminary Vehicle Investigation Report(PVIR)

CAIR# 10850016

YEAR	BRAND	VEHICLE IDENTIFICATION NUMBER		MO/DY-HR	ODOMETER	SERVICE DATE
2002	JEEP LIBERTY LTD EDITION 4X4 SPORT UTILITY 4-DR	1J8GL58K32W [REDACTED]		03-15 21	19323	04/21/2002
NAME OF OWNER		ADDRESS/LOCATION		CITY		STATE
[REDACTED]		[REDACTED]		FAIRFIELD		CA
ZIP	COLOR	MODEL	HOME PHONE		BUSINESS PHONE	
[REDACTED]	Bright Silver Metallic Clear Coat	KJJ	[REDACTED]			
SELLING DEALER NAME		ZONE	DLR. CODE	CITY	STATE	
DODGE-CHRY-JEEP OF VACAVILLE		71	44517	VACAVILLE	CA	
INSPECTOR - NAME FIRST, LAST, MIDDLE			INSPECTOR'S COMPANY		INSPECTOR'S PHONE NO.	
BOB LEWIS E			EAA		916-782-8712	
DAMAGE ESTIMATE				REPAIR ESTIMATE		
<input checked="" type="radio"/> MINOR <input type="radio"/> MODERATE <input type="radio"/> TOTAL LOSS				\$ 1.00		

INTERVIEW

INTERVIEW WITH:

DRIVER OWNER OTHER DRIVER/OWNER

NAME: LAST, FIRST, MIDDLE

[REDACTED]

INTERVIEW DATE:

DATE OF INCIDENT:

TIME OF INCIDENT

INSPECTION DATE:

01/21/2003

01/14/2002

02:00 AM PM

01/22/2003

1. DRIVER'S

DESCRIPTION OF EVENT:

MS. [REDACTED] OWNERS' FRIEND, WAS DRIVING ON A SMOOTH RESIDENTIAL ROAD, WHEN THE AIR BAGS SUDDENLY DEPLOYED, WITH NO IMPACT TO THE VEHICLE. HER INSURANCE COMPANY INSPECTED THE VEHICLE ON 01/21/2003 AND INFORMED HER IT IS DC'S RESPONSIBILITY AND THEY ARE NOT HANDLING HER CLAIM.

Insurance

Company

USAA

Name:

Personal Injury:

Were there

Personal

Injuries?

Any Indicator/

Warning Lights

on Prior?

Yes No

If Yes, complete section "B"

Yes No

If Yes, What light: **CHIME WENT OFF**

IMPORTANT: SHOW THIS REPORT TO NO ONE & ONLY STATE FACTS (DRAW NO CONCLUSIONS)

Help Key

PART A- GENERAL

REQUIRED PHOTOGRAPHS:

ALL FOUR SIDE VIEWS

IF CRASH DAMAGED:

PERSPECTIVE FROM EVERY CORNER OF VEHICLE DOWN BOTH ORIGINAL LATERAL SIGHT LINES(8 TOTAL)

- ANY RECENT VEHICLE SERVICE

YES NO

UNKNOWN

IF YES, ENCLOSE COPIES OF REPAIR ORDERS

INFORMATION:

POLICE/AGENCY REPORT #:

NONE

ALL REPORTS/PHOTOS BY OTHERS

- ADDRESS OF INSPECTION

Address **VACAVILLE D-C-J**

1

Address **681 ORANGE DR.**

2

City **VACAVILLE**

State **CA**

Zip **95687**

PHONE

- EVIDENCE OF TAMPERING OR PRIOR DISASSEMBLY

YES NO

- IF YES, DESCRIBE AND PHOTOGRAPH

PART B - EXTERIOR/INTERIOR VEHICLE DAMAGE

REQUIRED PHOTOGRAPHS:

WINDSHIELD

ALL AREAS OF DAMAGE MARKINGS ON INTERIOR AND EXTERIOR

CLOSE UPS OF STAINS, SKIN, HAIR, CLOTH

EXTERIOR AND INTERIOR DAMAGE INCLUDING UNDERCARRIAGE

INFORMATION:

DESCRIBE ANY INJURIES TO DRIVER AND/OR OTHER OCCUPANTS

SEE SEAT BELT/SEATS SECTION IF APPLICABLE

AIR BAG DEPLOYMENT INJURED MS. [REDACTED] NECK, SHOULDER AND ARM. SHE WAS TREATED BY DOCTOR LISA SATO-707-448-9350. 01/22/2003-NO DAMAGE TO THE EXTERIOR OR UNDERCARRAGE OF THE VEHICLE.

Next

PART C - AIRBAG(S)

REQUIRED PHOTOGRAPHS

- STEERING WHEEL
- AIRBAG(S)
- KNEE BLOCKERS
- ALL POSSIBLE LOCATIONS OF CONTACT

AECM INFORMATION

- SOFTWARE VERSION:

N/A

- SERIAL NUMBER :

N/A

- PART NUMBER :

N/A

- DOES AIRBAG WARNING LIGHT CYCLE ON?

YES NO N/A

- ARE WARNING LABELS PRESENT (PHOTO)

YES NO N/A

- RECORD LABEL PART NUMBER

NONE

COMPLETE PART D

- PHOTOGRAPH REQUIRED FOR DRB SCREENS & RECORD FAULTS
 - WERE THERE DRB READINGS TAKEN?

YES NO IF NO, EXPLAIN

AIR BAG MODULE SHORTERED.

- RECORD ACTIVE DTC'S EXACTLY AS APPEAR :	MIN	COUNT
SEE COMMENTS		
- RECORD STORED DTC'S (MINUTES/COUNTS) :	MIN	COUNT
SEE COMMENTS		

- WAS AIRBAG DEPLOYED?

DRIVER YES NO

IF NO, EXPLAIN

PASSENGER YES NO

IF NO, EXPLAIN

SIDE AIRBAG YES NO N/A

IF NO, EXPLAIN **SEE PHOTOS**

- WHICH SIDE DEPLOYED?

LEFT RIGHT N/A BOTH

- TYPE OF SIDE AIRBAG

SEAT CURTAIN N/A

- TYPE OF STEERING WHEEL

TILT STANDARD

- ANY DAMAGE TO STEERING WHEEL

YES NO

IF YES, EXPLAIN

DO NOT ERASE DRB READINGS

IS VEHICLE EQUIPPED WITH PASSENGER AIRBAG DEFAULT SWITCH?

YES NO

IF YES,

NOTE POSITION OF PASSENGER A/B SWITCH

ON OFF N/A

- EVIDENCE OF TAMPERING OR DISASSEMBLY?

YES NO N/A

IF YES, EXPLAIN

CHECK ENTIRE UNDERBODY FOR HIDDEN DAMAGE INCLUDING FRONT AND REAR SUSPENSION COMPONENTS

- UNDERBODY DAMAGED?

YES NO

IF YES, EXPLAIN

PHOTOGRAPH REQUIRED

PART D - SEATS/SHOULDER BELTS

REQUIRED PHOTOGRAPHS:

- OVERALL SEAT BELTS I/B & O/B
- CLOSE UP OF ANY IRREGULARITIES
- LATCHPLATE WEAR
- CLOSE UP D-RING TO SHOW LOADING
- OVERALL OF SEAT
- CLOSE UP OF DAMAGE
- RECORD DTC'S:

INFORMATION:

- LOCATE SEAT BELT LABELS AND RECORD ALL INFORMATION (SOME LABELS ARE SEWN TO WEBBING, OTHER LABELS ARE ON THE RETRACTOR FRAME: INBOARD SEAT BELT LABELS ARE NEAR THE FLOOR):

NONE

- RECORD ALL INFORMATION STAMPED ON LATCHPLATE

DRIVER-TD071-33014254-D22
PASSENGER-TD061-33014254-D22

- PRETENSION DEPLOYED?

YES NO UNKNOWN

- EXISTING LOCATION OF RECLINER - DESCRIBE THE LOCATION AND PICTURE OF SEAT BACK WITH B PILLOR AS REFERENCE AND INCLINOMETER READING

SEE PHOTOS

EXISTING LOCATION OF HEAD RESTRAINT (MEASURE GAP UNDER HEAD RESTRAINT):

IF ALLOWED. FUNCTION BELTS TO INSURE THEY **FUNCTION PROPERLY**

NOTE RESULTS

- DOES THE BUCKLE LATCH?

YES NO

IF NO, EXPLAIN

- DO THEY RELEASE?

YES NO

IF NO, EXPLAIN

- DO THEY RETRACT?

YES NO

IF NO, EXPLAIN

- ANY LOOSENESS OR BROKEN PARTS

YES NO

IF YES, EXPLAIN?

- CHECK FOR SEAT RETAINING BOLTS

NORMAL

BROKEN

LOOSE

MISSING

- NOTE AND RECORD APPROX. SEAT TRACK OVERLAP

SEE PHOTOS

PART - E TRANSMISSION NOT APPLICABLE

Previous

Next

PART - F UNINTENDED ACCELERATION NOT APPLICABLE

PART - G BRAKES NOT APPLICABLE

PART - H STEERING/SUSPENSION/TIRES NOT APPLICABLE

PART I - AXLE/DIFFERENTIAL

REQUIRED

PHOTOGRAPHS:

ENTIRE AXLE AND
CLOSE UP OF LEAKS

INFORMATION:

- VEHICLE ON HOIST:

REAR WHEEL DRIVE:

- RECORD AMOUNT OF LATERAL AXLE MOVEMENT OF EACH SIDE AND WILL WHEELS
TURN:

TRANS. AXLE - ROTATE WHEELS

- NOTE FUNCTION:

PART J - ADDITIONAL COMMENTS (DO NOT DRAW ANY CONCLUSIONS)

01/21/2003-CALLED VACAVILLE D-C-J AND ARRANGED TO INSPECT THE VEHICLE ON 01/22/2003, A.M.
CALLED OWNER, NOT IN, LEFT MESSAGE. 01/21/2003-P.M.-CONTACTED DRIVER, MS. [REDACTED] AND
INTERVIEWED HER FOR ADDITIONAL FACTS ON THE INCIDENT. INSPECTED VEHICLE AND TOOK PHOTOS
AT VACAVILLE D-C-J. RAN DRB ON THE AIR BAG SYSTEM. COMPLETED ALL THE INFORMATION AND
PHOTOS OUTLINED ON THE PVIR FOR SEAT BELTS AND AIR BAGS. ADDITIONAL COMMENTS ARE
OUTLINED BELOW: *NO EXTERIOR OR UNDERCARRAGE DAMAGE. *TUG TEST ON THE SEAT BELTS
INDICATE THEY LOCK. *AIR BAG LIGHT STAYS ON. *DRB TEST WAS NOT ABLE TO OBTAIN ANY DTC`S.
DRB SCREEN MESSAGE WAS "UNABLE TO ID MODULE FOR ORC." *TECNICIAN, GREG PARSONS, AT
DEALERSHIP AND I, USING THE 2002 "BODY DIAGNOSIS SHOP MANUAL" DIAGNOSED THE NO
COMMUNICATION MESSAGE ON THE DRB TEST. REPAIR ORDER #135582 OUTLINES THE TESTS USED TO
LOCATE THE SHORTED AIR BAG MODULE CONCERN. AIR BAG MODULE WAS REMOVED AND HAD A BURNT
ELECTRICAL SMELL. *AIR BAG MODULE CODES FOLLOW: CHRY. PIN-P560105AG. CHRY. SIN-
TSPME0702E119339754C. CONTACTED ROY PORTERFIELD AT DC TO INFORM HIM OF THE AIR BAG
MODULE CONCERN. COMPLETED THE PVIR AND E-MAILED WITH THE PHOTOS TO DC. FAXED THE REPAIR
ORDERS TO DC.

Previous

EA12-001

CHRYSLER

10-4-2012

ENCLOSURE 4

FIELD DATA SUBJECT

CAIRs Backup

10961678

Gene's Chrysler



DODGE



Jeep



3400 Cushman Street
Fairbanks, Alaska 99701
907-452-7117
907-458-3247 fax
www.geneschrysler.com

FAX COVER SHEET

3 Pages to follow

TO Dave Bennis

Message _____

Claim for 2003 Liberty air bags
deployment. Refer to Car #10961678.

From: Kathy Immel

Date 04-02-03

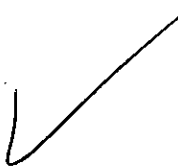

64398

WARRANTY

PAGE 1

HOME:

BUS:

SERVICE ADVISOR: 359 ROXY MARCY

COLOR	YEAR	MAKE/MODEL	VIN	LICENSE	MILEAGE IN/ OUT	TAG
BLU	03	JEEP LIBERTY	1J4GL48K73W [REDACTED]		16/28	T9709
DEL DATE	PROD. DATE	WARR. EXP.	PROMISED	PO NO.	RATE	PAYMENT
			17:00 25MAR03			CASH
R.O. OPENED	READY	OPTIONS: STK:2364181 DLR:63826 ENG:3.7 TRN:MANU				

09:50 21FEB03 15:24 25MAR03
 LINE OPCODE TECH TYPE HOURS LIST NET TOTAL
 A AIR BAG DEPLOYED WHILE IDLING
 CAUSE: SEE TECH NOTES
 08900201 WIRING HARNESS, AIR INSTRUMENT PANEL → 08909001 (3.4) → 255.68
 08901509 (1.5) → 112.80
 REFER TO CAIR # 10961678

08900201 WIRING HARNESS, AIR INSTRUMENT PANEL	08909001 (3.4)	→	255.68
08901509 WIRING HARNESS, BODY	08901509 (1.5)	→	112.80
1 56010509AG WIRING	317.00	266.00	266.00
1 56010364AG WIRING-INSTRUMENT PANEL	300.00	252.00	252.00
1 5HG331DVAH SEAT BELT-FRONT OUTER	260.00	218.40	218.40
1 55315033AC SLIDE-SEAT BELT TURNING L	25.00	21.00	21.00
1 FRT FREIGHT	35.00	35.00	35.00
1 DAY FRT CHARGE			
1 FRT FREIGHT	146.67	146.67	146.67
SH FRT CHARGE			
1 5066386AA *COOLANT	14.25	12.39	12.39
FC: PART#: COUNT:			
CLAIM TYPE:			
AUTH CODE:			
2663			
08906504 WIRING HARNESS, ENGINE COMPARTMENT AND HEADLAMP-Replace (B)			
479 W 1.20		90.24	90.24
1 56009954AP WIRING-HEADLAMP TO DASH	430.00	361.20	361.20
FC: PART#: COUNT:			
CLAIM TYPE:			
AUTH CODE:			
2663			
23115001 AIRBAG, PASSENGER-Replace (A)			N/C
479 W 0.50		37.60	37.60
1 5GG30DX9AE AIRBAG	397.00	333.20	333.20
FC: PART#: COUNT:			
CLAIM TYPE:			
AUTH CODE: F			
2663			
06142522 SENSOR, AIR BAG IMPACT-Replace (H) only left Replaced			

DEALERSHIP WARRANTY

 90 DAYS OR 4,000 MILES ON PARTS & LABOR.
 CHRYSLER (MOPAR) LIMITED WARRANTY

 12 MONTHS OR 12,000 MILES PARTS & LABOR.

STATEMENT OF DISCLAIMER
 All warranties on the product sold hereby are those made by the manufacturer. The Seller, GENE'S CHRYSLER, hereby expressly disclaims all warranties, either express or implied, including any implied warranty of merchantability or fitness for a particular purpose, and GENE'S CHRYSLER neither assumes nor authorizes any other person to assume for it any liability in connection with this sale. Not responsible for loss or damage to car or articles left in cars in case of fire, theft or any other cause beyond our control. I hereby authorize the above repair work to be done along with the necessary material and hereby grant you and/or your employees permission to operate the vehicle described on the streets, highways or elsewhere for the purpose of testing and/or inspection. An express mechanic's lien is hereby acknowledged on the above vehicle to secure the amount of repairs thereto.
 CUSTOMER SIGNATURE

DESCRIPTION	TOTALS
LABOR AMOUNT	
PARTS AMOUNT	
GAS, OIL, LUBE	
SUBLET AMOUNT	
MISC. CHARGES	
TOTAL CHARGES	
LESS INSURANCE	
SALES TAX	
PLEASE PAY THIS AMOUNT	

64398

WARRANTY

PAGE 2

HOME:

BUS:

SERVICE ADVISOR: 359 ROXY MARCY

COLOR	YEAR	MAKE/MODEL	VIN	LICENSE	MILEAGE IN/ OUT	TAG	
BLU	03	JEEP LIBERTY	1J4GL48K73W [REDACTED]		16/28	T9709	
DEL DATE	PROD. DATE	WARR. EXP.	PROMISED	PO NO.	RATE	PAYMENT	INV. DATE
			17:00 25MAR03			CASH	25MAR2003
R.O. OPENED	READY	OPTIONS: STK:2364181 DLR:63826 ENG:3.7 TRN:MANJ					
09:50 21FEB03	15:24 25MAR03						

LINE	OPCODE	TECH	TYPE	HOURS	LIST	NET	TOTAL	
		479	W	0.30		22.56	22.56	
08142503		SENSOR, AIR BAG IMPACT-Replace (B)						
		479	W	0.30		22.56	22.56	
1	56010319AB	SENSOR			37.10	31.15	31.15	
	FC: PART#: COUNT:							
	CLAIM TYPE:							
	AUTH CODE:							
	2663							
08450901		MODULE, AIR BAG/OCCUPANT RESTRAINT CONTROL-Replace (A)						
		479	W	0.40		30.08	30.08	
1	56010501AI	MODULE-OCCUPANT RESTRAINT			114.00	95.69	95.69	
	FC: PART#: COUNT:							
	CLAIM TYPE:							
	AUTH CODE:							
	2663							
19852502		CLOCKSPRING-Replace (B)						
		479	W	0.40		30.08	30.08	
1	56010146AE	CLKSPRING			110.00	92.33	92.33	
	FC: PART#: COUNT:							
	CLAIM TYPE:							
	AUTH CODE:							
	2663							

120240 186503 TPARTS
21837 45120 TLABOR

28 REMOVED INSTRUMENT PANEL & FRONT SEATS & ALSO ALL FRONT TRIM PANELS, REMOVED INSTRUMENT PANEL WIRING HARNESS & REMOVED FRONT BODY WIRING HARNESS & REPLACED BOTH WIRING HARNESS'S, REMOVED HEADLAMP TO I/P HARNESS & REPLACED ALSO WITH NEW WIRING HARNESS, REPLACED FRONT AIR BAG IMPACT SENSORS, REPLACED AIR BAG CONTROL MODULE FOR HAVING SHORDED & CAUSING LEFT AIR BAG & SEAT BELT TO DEPLOY WITHOUT VEHICLE BEING IMPACTED OR HIT, INSTALLED ALL NEW WIRING & SENSORS & AIRBAG CONTROL MODULE, & SEAT BELT ASSY. REINSTALLED RADIATOR, RADIATOR WAS REMOVED TO GET TO FRONT WIRING, FILLED WITH COOLANT & VERIFIED THAT ALL AIR WAS OUT OF

STATEMENT OF DISCLAIMER		DESCRIPTION	TOTALS
DEALERSHIP WARRANTY *** 90 DAYS OR 4,000 MILES ON PARTS & LABOR. CHRYSLER (MOPAR) LIMITED WARRANTY *** 12 MONTHS OR 12,000 MILES PARTS & LABOR.	All warranties on the product sold hereby are those made by the manufacturer. The Seller, GENE'S CHRYSLER, hereby expressly disclaims all warranties, either express or implied, including any implied warranty of merchantability or fitness for a particular purpose, and GENE'S CHRYSLER neither assumes nor authorizes any other person to assume for it any liability in connection with this sale. Not responsible for loss or damage to car or articles left in cars in case of fire, theft or any other cause beyond our control. I hereby authorize the above repair work to be done along with the necessary material and hereby grant you and/or your employees permission to operate the vehicle described on the streets, highways or elsewhere for the purpose of testing and/or inspection. An express mechanic's lien is hereby acknowledged on the above vehicle to secure the amount of repairs thereto.	LABOR AMOUNT	
		PARTS AMOUNT	
		GAS, OIL, LUBE	
		SUBLET AMOUNT	
		MISC. CHARGES	
		TOTAL CHARGES	
		LESS INSURANCE	
		SALES TAX	
CUSTOMER SIGNATURE	PLEASE PAY THIS AMOUNT		

6 4 3 9 8

WARRANTY

PAGE 3

HOME:

BUS:

SERVICE ADVISOR: 359 ROXY MARCY

COLOR	YEAR	MAKE/MODEL	VIN	LICENSE	MILEAGE IN/ OUT	TAG	
BLU	03	JEEP LIBERTY	1J4GL48K73W		16/28	T9709	
DEL DATE	PROD. DATE	WARR. EXP.	PROMISED	PO NO.	RATE	PAYMENT	INV. DATE
			17:00 25MAR03			CASH	25MAR2003
R.O. OPENED	READY	OPTIONS: STK:2364181 DLR:63826 ENG:3.7 TRN:MANU					
09:50 21FEB03	15:24 25MAR03						

LINE	OPCODE	TECH	TYPE	HOURS	LIST	NET	TOTAL
------	--------	------	------	-------	------	-----	-------

SYSTEM, REINSTALLED FRONT SEATS, REINSTALLED INSTRUMENT PANEL, REINSTALL GAUGE CLUSTER & RADIO & REINSTALL HEATER, CONTROLS, ALS O REINSTALLED STEERING COLUMN WITH NEW CLOCK SP RING & REINSTALL TURN SIGNAL ASSY., REINSTALL B GLOVE BOX & ALL TRIM PANEL FOR I/P, & DOOR SILLS AND KICK PANELS, TEST DROVE AFTER REINSTALLING ALL PARTS NO AIR BAG LIGHTS CAME ON & NO OTHER DTCS WERE PRESENT DROVE FOR TWELVE MILES NO PROBLEMS FOUND & NO RATTLING FOUND FROM TRIM.

B** PRE PAID FRIEGHT

CAUSE:

0 FREIGHT

479 W 0.00
 1 FRT FREIGHT
 FC: PART#: COUNT:
 CLAIM TYPE:
 AUTH CODE:
 2663

	0.00	0.00
11.54	11.54	11.54

pre-paid freight

0	1154	TPARTS
0	0	TLABOR

28

COST, SALE, & COMP TOTALS 142077 232777 0

DEALERSHIP WARRANTY 90 DAYS OR 4,000 MILES ON PARTS & LABOR. CHRYSLER (MOPAR) LIMITED WARRANTY 12 MONTHS OR 12,000 MILES PARTS & LABOR.	STATEMENT OF DISCLAIMER All warranties on the product sold hereby are those made by the manufacturer. The Seller, GENE'S CHRYSLER, hereby expressly disclaims all warranties, either express or implied, including any implied warranty of merchantability or fitness for a particular purpose, and GENE'S CHRYSLER neither assumes nor authorizes any other person to assume for it any liability in connection with this sale. Not responsible for loss or damage to car or articles left in cars in case of fire, theft or any other cause beyond our control. I hereby authorize the above repair work to be done along with the necessary material and hereby grant you and/or your employees permission to operate the vehicle described on the streets, highways or elsewhere for the purpose of testing and/or inspection. An express mechanic's lien is hereby acknowledged on the above vehicle to secure the amount of repairs thereto.	DESCRIPTION	TOTALS
		LABOR AMOUNT	451.20
	PARTS AMOUNT	1876.57	
	GAS, OIL, LUBE	0.00	
	SUBLET AMOUNT	0.00	
	MISC. CHARGES	0.00	
	TOTAL CHARGES	2327.77	
	LESS INSURANCE	0.00	
	SALES TAX	0.00	
CUSTOMER SIGNATURE	PLEASE PAY THIS AMOUNT	2327.77	

7541.44

WARRANTY COPY

2406.47

April 7, 2003

Jeans Chrysler Jeep
Attn: Kathy Immel
3400 S. Cushman Street
Fairbanks, AK 99701

Reference No.: 10961678

V.I.N.: 1J4GL48K73W [REDACTED]

Dear Mr. Immel:

Enclosed you will find DaimlerChrysler check number 6320554 in the amount of \$2,406.47.

The amount of this check will represent reimbursement for the repairs performed on Mr. [REDACTED] 2003 Jeep Liberty Sport.

Thank you for your courtesy and cooperation in the repair of this vehicle.

Sincerely,

D. M. Bennis
Special Investigations
(248) 944-7036

DMB/kat

Enclosure(s)

VENDOR NO: SU00000001
 VENDOR LOC:
 FACTOR VENDOR:
 FACTOR VENDOR LOC:

REMITTANCE ADVICE
 DAIMLERCHRYSLER CORPORATION
 CIMS: 431-00-00
 P.O. BOX 21-8004
 AUBURN HILLS MI 48321-8004

PAY REF. NO: 0006320554
 DATE: 04/04/2003
 PH: USCKU SOURCE: SU
 MAIL: R:SU

INV/REF DATE	INVOICE/REFERENCE NUMBER-SCHEDULE PAY NO.	GROSS AMOUNT	DISCOUNT AMOUNT	NET AMOUNT
04/03/2003 ZONE 82	10961678 VIN 1J4GL48K73M549709	2,406.47		2,406.47
TOTALS		2,406.47		2,406.47

REMOVE CHECK ALONG THIS PERFORATION

THIS CHECK HAS A SECURITY FEATURE THAT WILL APPEAR IF ALTERED.

DAIMLERCHRYSLER GAP CHASE MANHATTAN BANK USA, N.A.
 WILMINGTON, DELAWARE

62-26 1530-09 0006320554
 311

DATE: 04/04/2003 SEQUENCE NO. 00036 PAY 5000000000002406AND47CENTS *****2406.47

PAY TO THE ORDER OF
 [REDACTED]

VOID SIX MONTHS AFTER DATE OF ISSUE
 ACCOUNT 7601 BANK USCKU
 DAIMLERCHRYSLER CORPORATION
 AUTHORIZED SIGNER
T.P. Dykstra

FAIRBANKS AK [REDACTED]

1587218

SEE REVERSE SIDE FOR OPENING INSTRUCTIONS

DAIMLERCHRYSLER
 CORPORATE PAYMENTS GAP
 CIMS: 431-00-00
 P.O. BOX 21-8004
 AUBURN HILLS MI 48321-8004

USCKU SU 0006320554 R:SU

FAIRBANKS AK [REDACTED]

2855-0709-0222 Moon North America ©2000, SecureScan® Patents 5,018,767; 5,193,853; and other patents pending. PressureSeal Patent 4,918,128. - 0221

10961678

Gene's Chrysler Center
3400 Cushman St
Fairbanks, AK 99701

urgent

f a c s i m i l e

To: Dave Bennis
Fax Number: 91-248-512-8748,,,2094

From: Jim Scoles
Fax Number: 907-458-3251
Business Phone: 907-458-3250
Home Phone:

Pages: 6
Date/Time: 2/25/2003 12:44:42 PM
Subject: CAIR # 10961678

Kelly & Dave,

Attached you will find documentation regarding 03 Jeep Liberty that dispatched the airbag. I will await your response to move forward. I am not a lawyer but when you read the Alaska Statute's it appears we have exceeded the 5% rule for "replacement" vs repair.

Dave - just let Kelly or I know if you want photo's for the module we took from vehicle. Thanks for you rtime.

Respectfully,

Jim Scoles

Gene's Chrysler Center

Your Five Star Dealership

3400 Cushman St.
Fairbanks, AK 99701
907-458-3200
jims@geneschrysler.com
www.geneschrysler.com

ESTIMATE

DATE: 25Feb03

To: Dave Bennis
Daimler Chrysler Corp
Special Investigations
Fax: 248-512-8748
Voice: 248-944-7036

Phone: 907-458-3250 direct line
Estimated By: Jim Scoles - S & P Director
Start Date: Upon your approval
Location: Gene's Chrysler Center
Job Phone:

TERMS: Net 30 Days

JOB DESCRIPTION

Repair as directed by DCX for airbag deploying without an event present – Special Investigations report on file with DCX by David B. Vial

***** Mr. Bennis: please note, Rick Monsey (Shop Foreman) disassembled control module and found burnt "computer chip" in module. I have taken digital photos. Will forward those photos to DOM – Kelly Linn. If you Request them, please contact Kelly unless you want to send your e-mail address to jims@geneschrysler.com I will be happy to send directly to you. Thanks—jbs

ITEMIZED ESTIMATE

Part list and labor on attached documents-----	
Parts total with markup	\$1968.12
Labor – total 9.9hrs sold @ \$75.20 per hr Warranty Rate	\$744.48
TOTAL ESTIMATED JOB COST	\$2712.60

***** Note – MSRP = \$20,830 – total repair far exceeds Alaska Statute 45.25.510 (attch)

This is an estimate only, not a contract for services. This estimate is for completing the job as described above. It is based on our evaluation and does not include material price increases or additional labor and materials which may be required should unforeseen problems arise after the work has started.

Page 19 line 11

Sec. 45.25.510. Disclosure of damages.

- (a) Before entering into a new motor vehicle sales contract, a new motor vehicle dealer shall disclose in writing to a buyer of the new motor vehicle any known damage and repair to the new motor vehicle if the damage exceeds five percent of the manufacturer's suggested retail price as calculated at the dealer's authorized warranty rate for labor and parts or \$1000.00 whichever is greater. A new motor vehicle dealer is not required to disclose to a buyer that glass, tires, bumpers, or cosmetic parts of a new motor vehicle were damaged at any time if the damaged item has been replaced with original or comparable equipment. A replaced part is not part of the cumulative damage required to be disclosed under this subsection.
- (b) If disclosure is not required under this section, a buyer may not revoke or rescind a sales contract due to the fact that the new motor vehicle was damaged and repaired before completion of the sale.
- (c) In this section,
- (1) "cosmetic parts" means parts that are attached by and can be replaced in total through the use of screws, bolts, or other fasteners without the use of welding or thermal cutting and includes windshields, bumpers, hoods, or trim panels;
- (2) "manufacturer's suggested retail price" means the retail price of the new motor vehicle suggested by the manufacturer and includes the retail delivered price suggested by the manufacturer for each accessory or item of optional equipment physically attached to the new motor vehicle at the time of delivery to the new motor vehicle dealer that is not included within the retail price suggested by the manufacturer financing approval.

Page 21 line 18

- (d) If a buyer's final financing is not approved **[within seven business days**

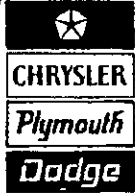

GENE'S CHRYSLER

3400 CUSHMAN STREET
 FAIRBANKS, ALASKA 99701



907-458-3200
 800-478-4363
 907-451-7747 (Parts Hotline)
 907-458-3274 (Parts Dept. Fax)

NO RETURNS ON ELECTRICAL OR SPECIAL ORDERED PARTS.
 ALL RETURNS ARE SUBJECT TO A 20% HANDLING CHARGE.

ALL PARTS RETURNED FOR CREDIT MUST BE IN ORIGINAL PACKAGE WITH PURCHASE INVOICE OR CREDIT WILL BE REFUSED.

DISCLAIMER OF WARRANTIES: Any warranties on the products sold hereby are those made by the manufacturers. The seller hereby expressly disclaims all warranties, either express or implied, including any implied warranty of merchantability or fitness for a particular purpose, and neither assume nor authorizes any other person to assume for it any liability in connection with the sale of said products. Customer shall not be entitled to recover any consequential damages, damages to property, damages for loss of use, loss of time, loss of profits, or income, or any other incidental damages.

DATE ENTERED 25 FEB 03	YOUR ORDER NO.	DATE SHIPPED 25 FEB 03	INVOICE DATE	INVOICE NUMBER 44343
---------------------------	----------------	---------------------------	--------------	-------------------------

S
O
L
D
T
O

ACCOUNT NO. 98

GENE'S CHRYSLER CENTER
 CAIR#10961678
 2003 JEEP LIBERTY

QUOTE

S
H
I
P
T
O

CASH WHOLESALE

PAGE 1 OF 1
 Q44343

SHIP VIA		SLSM.	B/L NO.	TERMS	F.O.B. POINT		
		348		CASH	FAIRBANKS AK		
QTY	UNIT	PART NO.	DESCRIPTION	LIST	NET	AMOUNT	
1	0	5G330DX9AE 279D	AIRBAG	333.20	333.20	333.20	
1	0	56010501AH	MODULE-OCCU	95.69	95.69	95.69	
1	0	56010146AF	CLKSPRING	92.33	92.33	92.33	
1	0	56010509AG	WIRING	266.00	266.00	266.00	
1	0	56010363AC	WIRING-INST	266.00	266.00	266.00	
1	0	56010364AG	WIRING-INST	252.00	252.00	252.00	
1	0	5HG331DVAF	SEAT BELT-F	218.40	218.40	218.40	
1	0	55315033AC	SLIDE-SEAT	21.00	21.00	21.00	
1	0	56010319AB	SENSOR	31.15	31.15	31.15	
1	0	56010412AC 204F	SENSOR	31.15	31.15	31.15	
1	0	56009954AO	WIRING-HEAD	361.20	361.20	361.20	
1	0	LABOR	9.9HRS @75.20	893.38	744.48	744.48	
**** I N V O I C E Q U O T E - DO NOT PAY ****							
All parts include 46% markup							
All labor sold @ Warranty Rate - 75.20 per hr							
***** VISIT US ON THE INTERNET! *****				PARTS		2,712.60	
***** www.geneschrysler.com *****				SUBLET			
*****				FREIGHT		0.00	
*****				SALES TAX		0.00	
*****				TOTAL		\$2,712.60	
CUSTOMER'S SIGNATURE							
X							

THANK
 YOU
 FOR
 YOUR
 BUSINESS!

CUSTOMER COPY

6 4 3 9 8

CUSTOMER #:

WORKORDER



GENE'S CHRYSLER



3400 CUSHMAN STREET
FAIRBANKS, ALASKA 99701

(907) 452-7117 FAX (907) 458-3247

HOME:

BUS:

SERVICE ADVISOR: 359 MARCY, ROXY

COLOR	YEAR	MAKE/MODEL	VIN	LICENSE	MILEAGE IN/ OUT	TAG
BLU	03	JEEP LIBERTY	1J4GL48K73W		16 1/	T9709
DEL DATE	PROD DATE	WARR EXP	PROMISED	PO NO	RATE	PAYMENT
			17:00 28FEB03			CASH
R.O. OPENED	READY	OPTIONS: STK:2364181 DLR:63826 ENG:3.7 TRN:MANU				
21FEB2003 09:50						

LINE	OP CODE	TECH	TYPE	DESCRIPTIONS/INSTRUCTIONS
# 1	A	S100	W	AIR BAG DEPLOYED WHILE IDLING

Ken

2-21-03 10:15 AM
Star -

- Impact sensors Resistance -

- 08-45-09-01 .4
- 19-85-25-02 .4
- 23-13-01-05 .5
- 23-13-09-03 .3
- 08-90-75-08 3.3
- 08-90-90-01 3.4
- 08-90-65-04 1.0
- 08-14-25-03 .3
- 08-14-25-04 .3

(Drivers Air Bag A/T?)
clock spring
NA fit seat Belt & turning loop adjuster
Air Bag control module (ORC)
Body wiring Harness
Instrument panel wiring Harness
Head lamp to dash wiring Harness
Frt Impact sensors

75.20

I hereby authorize the repair work to be done along with the necessary materials. You and/or your employees may operate the vehicle for the purpose of testing, inspection or delivery at my risk. An express mechanic's lien is acknowledged on vehicle to secure the amount of repairs thereto. You will not be held responsible for loss or damage to vehicle or articles left in vehicle in case of fire, theft, accident or any other cause beyond your control or for any delays caused by unavailability of parts or delays in parts shipments by the supplier or transporter.

PRELIMINARY ESTIMATE \$ _____

AUTHORIZED BY X

REVISED ESTIMATE (1)	DATE	TIME	BY
REVISED ESTIMATE (2)			
REVISED ESTIMATE (3)			

I HEREBY ACKNOWLEDGE THAT I WAS NOTIFIED & GAVE ORAL APPROVAL OF THE ABOVE REVISED ESTIMATES:

X

CUSHMAN SERVICE

CHRYSLER

2364181

DAIMLERCHRYSLER MOTORS CORPORATION INVOICE

10050-A PLANT ZONE DEALER VEHICLE ID NO. INVOICE NO. INVOICE DT
 TOLEDO NORTH 72 63826 1J4GL48K73W [REDACTED] 3-KJJ-65108670 12/06/02

SHIP GENE'S CHRYSLER CENTER
 TO: PO BOX 70989
 FAIRBANKS AK 99707

IGN KEY M2307
 TRK KEY 2307
 ACC KEY 5390
 2462-01-C306

1114/03
 NK

SOLD GENE'S CHRYSLER CENTER
 TO: PO BOX 70989
 FAIRBANKS AK 99707

SHIPPING WT. 3805

PAID FOR BY: CHRYSLER FINANCIAL CORPORATION
 XX CREDIT SALE CASH SALE

SAE HP 32.2
 000-222222-75

BODY & EQUIP. DESCRIPTION FACTORY WHOLESALE PRICE

KJJH74	JEEP LIBERTY SPORT 4WD	17,908.00
PB7	Patriot Blue Pearl Coat	
MSDV	Seats - Cloth High-Back Bucket	NO CHARGE
AHM	Convenience Group I	167.00
DDD	Transmission - 5-Speed HD Manual	
EKG	Engine - 3.7L Power Tech V6	765.00
NHK	Engine Block Heater	36.00
RBK	Radio-AM/FM Compact Disc w/Chgr Ctrl	113.00
YDH	DaimlerChrysler Owner Loyalty Mail	20.00
2TA	Customer Preferred Package 2TA	
26A	Customer Preferred Package 26A	
3VC	Customer Preferred Discount	
E55	ALASKA - DAA	205.00
L55	ALASKA - PPA/EB-PF	210.00
461	DESTINATION CHARGE	610.00
	HB 60700	

MDH # 120409
 EP 18787

\$24,224.00

MSRP RETAIL TOTAL 20,830.00 TOTAL 20,034.00
 ORIGINAL INVOICE

THIS VEHICLE IS MANUFACTURED TO MEET SPECIFIC UNITED STATES REQUIREMENTS. THIS VEHICLE IS NOT MANUFACTURED FOR SALE OR REGISTRATION OUTSIDE OF THE UNITED STATES.

cairnumber :10961678

CONFIDENTIAL - Prior Approval Required Before Duplicating

Preliminary Vehicle Investigation Report(PVIR)

CAIR# 10961678

YEAR	BRAND	VEHICLE IDENTIFICATION NUMBER		MO/DY-HR	ODOMETER	SERVICE DATE
2003	JEEP LIBERTY SPORT 4X4 SPORT UTILITY 4-DR	1J4GL48K73W[REDACTED]		12-04 09	13	12/04/2002
NAME OF OWNER		ADDRESS/LOCATION		CITY		STATE
[REDACTED]		[REDACTED]		FAIRBANKS		AK
ZIP	COLOR	MODEL	HOME PHONE		BUSINESS PHONE	
[REDACTED]	Patriot Blue Pearl Coat	KJJ	[REDACTED]		[REDACTED]	
SELLING DEALER NAME		ZONE	DLR. CODE	CITY	STATE	
GENE'S CHRYSLER CENTER		71	63826	FAIRBANKS	AK	
INSPECTOR - NAME FIRST, LAST, MIDDLE			INSPECTOR'S COMPANY		INSPECTOR'S PHONE NO.	
David Vial B			EAA		253-851-3991	
DAMAGE ESTIMATE				REPAIR ESTIMATE		
<input checked="" type="radio"/> MINOR <input type="radio"/> MODERATE <input type="radio"/> TOTAL LOSS				\$ 2000.00		

INTERVIEW

INTERVIEW WITH: DRIVER OWNER OTHER DRIVER/OWNER

NAME: LAST, FIRST, MIDDLE [REDACTED]

INTERVIEW DATE:	DATE OF INCIDENT:	TIME OF INCIDENT	INSPECTION DATE:
02/20/2003	02/13/2003	08:00 <input type="radio"/> AM <input checked="" type="radio"/> PM	02/20/2003

1. DRIVER'S DESCRIPTION OF EVENT: **Dealerships shop foreman statement was the vehicle was moved off the sales lot so snow could be removed. The engine was left idling with heater switch on high speed and temperature setting at the highest level. The vehicle was apparently left idling as stated several hours – exact amount of time is not known. When returning to the vehicle at 4 hours the airbag had not deployed however when returning to the vehicle at the end of the day the driver side airbag had deployed.**

Insurance Company Name: **N/A**

Personal Injury: Were there Personal Injuries? Yes No

If Yes, complete section "B"

Any Indicator/Warning Lights on Prior? Yes No

If Yes, What light:

IMPORTANT: SHOW THIS REPORT TO NO ONE & ONLY STATE FACTS (DRAW NO CONCLUSIONS)

Help Key

PART A- GENERAL

REQUIRED PHOTOGRAPHS:

- ALL FOUR SIDE VIEWS
- IF CRASH DAMAGED:**
- PERSPECTIVE FROM EVERY CORNER OF VEHICLE DOWN BOTH ORIGINAL LATERAL SIGHT LINES(8 TOTAL)
- ANY RECENT VEHICLE SERVICE

YES NO

UNKNOWN

IF YES, ENCLOSE COPIES OF REPAIR ORDERS

INFORMATION:

- POLICE/AGENCY REPORT #:

N/A

- ALL REPORTS/PHOTOS BY OTHERS

- ADDRESS OF INSPECTION
 Address **3400 Cushman St.**
 1
 Address
 2
 City **Fairbanks**
 State **AK**
 Zip **99701**
 PHONE

- EVIDENCE OF TAMPERING OR PRIOR DISASSEMBLY

YES NO

- IF YES, DESCRIBE AND PHOTOGRAPH

PART B - EXTERIOR/INTERIOR VEHICLE DAMAGE

REQUIRED PHOTOGRAPHS: N/A

- WINDSHIELD
- ALL AREAS OF DAMAGE MARKINGS ON INTERIOR AND EXTERIOR
- CLOSE UPS OF STAINS, SKIN, HAIR, CLOTH
- EXTERIOR AND INTERIOR DAMAGE INCLUDING UNDERCARRIAGE

INFORMATION:

- DESCRIBE ANY INJURIES TO DRIVER AND/OR OTHER OCCUPANTS
- SEE SEAT BELT/SEATS SECTION IF APPLICABLE

Next

cairnumber :10961678

PART C - AIRBAG(S)

REQUIRED PHOTOGRAPHS

- STEERING WHEEL
- AIRBAG(S)
- KNEE BLOCKERS
- ALL POSSIBLE LOCATIONS OF CONTACT

AECM INFORMATION

- SOFTWARE VERSION:

N/A

- SERIAL NUMBER :

TRFME3292E0212

- PART NUMBER :

P56010501AI

- DOES AIRBAG WARNING LIGHT CYCLE ON?

YES NO N/A

- ARE WARNING LABELS PRESENT (PHOTO)

YES NO N/A

- RECORD LABEL PART NUMBER

N/A

COMPLETE PART D

- PHOTOGRAPH REQUIRED FOR DRB SCREENS & RECORD FAULTS
- WERE THERE DRB READINGS TAKEN?

YES NO IF NO, EXPLAIN

- RECORD ACTIVE DTC'S EXACTLY AS APPEAR :	MIN	COUNT
No Communication with ABM	0	0
- RECORD STORED DTC'S (MINUTES/COUNTS) :	MIN	COUNT
No DTC's found	0	0

- WAS AIRBAG DEPLOYED?

DRIVER YES NO

IF NO, EXPLAIN

PASSENGER YES NO

IF NO, EXPLAIN

No Deployment

SIDE AIRBAG YES NO N/A

IF NO, EXPLAIN

Not equipt.

- WHICH SIDE DEPLOYED?

LEFT RIGHT N/A BOTH

- TYPE OF SIDE AIRBAG

SEAT CURTAIN N/A

- TYPE OF STEERING WHEEL

TILT STANDARD

- ANY DAMAGE TO STEERING WHEEL

YES NO

IF YES, EXPLAIN

DO NOT ERASE DRB READINGS

IS VEHICLE EQUIPPED WITH PASSENGER AIRBAG DEFAULT SWITCH?

YES NO

IF YES,

NOTE POSITION OF PASSENGER A/B SWITCH

ON OFF N/A

- EVIDENCE OF TAMPERING OR DISASSEMBLY?

YES NO N/A

IF YES, EXPLAIN

CHECK ENTIRE UNDERBODY FOR HIDDEN DAMAGE INCLUDING FRONT AND REAR SUSPENSION COMPONENTS

- UNDERBODY DAMAGED?

YES NO

IF YES, EXPLAIN

PHOTOGRAPH REQUIRED

PART - D SEATS/SHOULDER BELTS NOT APPLICABLE

PART - E TRANSMISSION NOT APPLICABLE

Previous

Next

PART - F UNINTENDED ACCELERATION NOT APPLICABLE

PART - G BRAKES NOT APPLICABLE

PART - H STEERING/SUSPENSION/TIRES NOT APPLICABLE

PART - I AXLE/DIFFERENTIAL NOT APPLICABLE

PART J - ADDITIONAL COMMENTS (DO NOT DRAW ANY CONCLUSIONS)

The vehicle was inspected at Gene's Chrysler, 3400 Cushman Street, Fairbanks, AK, on 02/20/2003. Facts: This vehicle driver side airbag had deployed. The driver side seat belt tensioner had also deployed. The following tests were performed. · The DRB III scan tool was used to for scan stored DTC's, photo "DRB III view of communication with all modules" will show communication with applicable modules. Please note there was no communication with the airbag module. · The only communication was with BCM, MTC, and RBK. · The airbag MIL with ignition key in run position was steady red and did not cycle off. · The center shift council was removed to expose ACM. The ACM yellow connector was in place and locked. Serial number of the module is P56010501AI. · The dummy connector was placed on ACM wire bulk connector. The following tests reveal: #8 cavity -driver side squib – low – 5.7 ohms and not steady. #5 cavity – driver side squib – high – 3.3 ohms and steady. #6 cavity – driver seat belt tensioner – 1290 ohms and not steady. · The driver doorsill molding was removed. The wire harness to seat belt was inspected for possible damage – none found. The wire harness under dash panel was inspected for damage and none was found. · The 2 - 10 ampere airbag fuses were in place and tested for continuity and tested for open. The bridges were intact. · The wiring schematics were reviewed with applicable service manual. All wire going to ACM bulkhead connector was in proper order. · The ACM module back cover was removed. The processor board was checked for any discolor, burn spots. None discovered. · Photos will show no damage from impact in the frontal areas of the vehicle. Summary: Dealer personnel discovered deployment after the vehicle had been idling for lengthily period of time (4 to 8 hours) with heater controls on high speed and high temperature settings. Inside cabin temperatures were not determined when the airbag deployed.

Previous

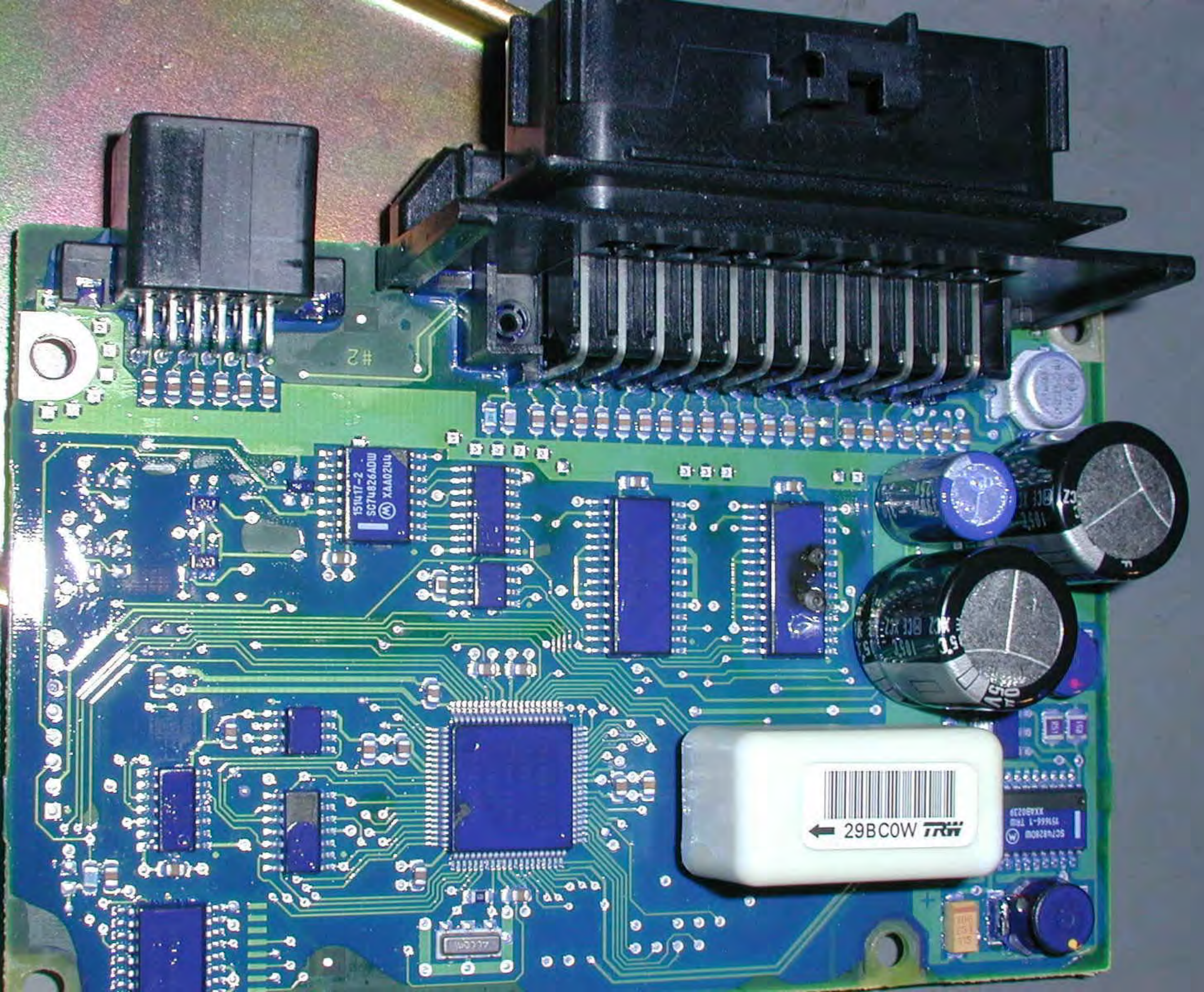

#2

1514T-2
SC74826ADIW
XAA0244

← 29BC0W TRW

SC74826ADIW
M08281205
19166-1 TRW
XAA0244



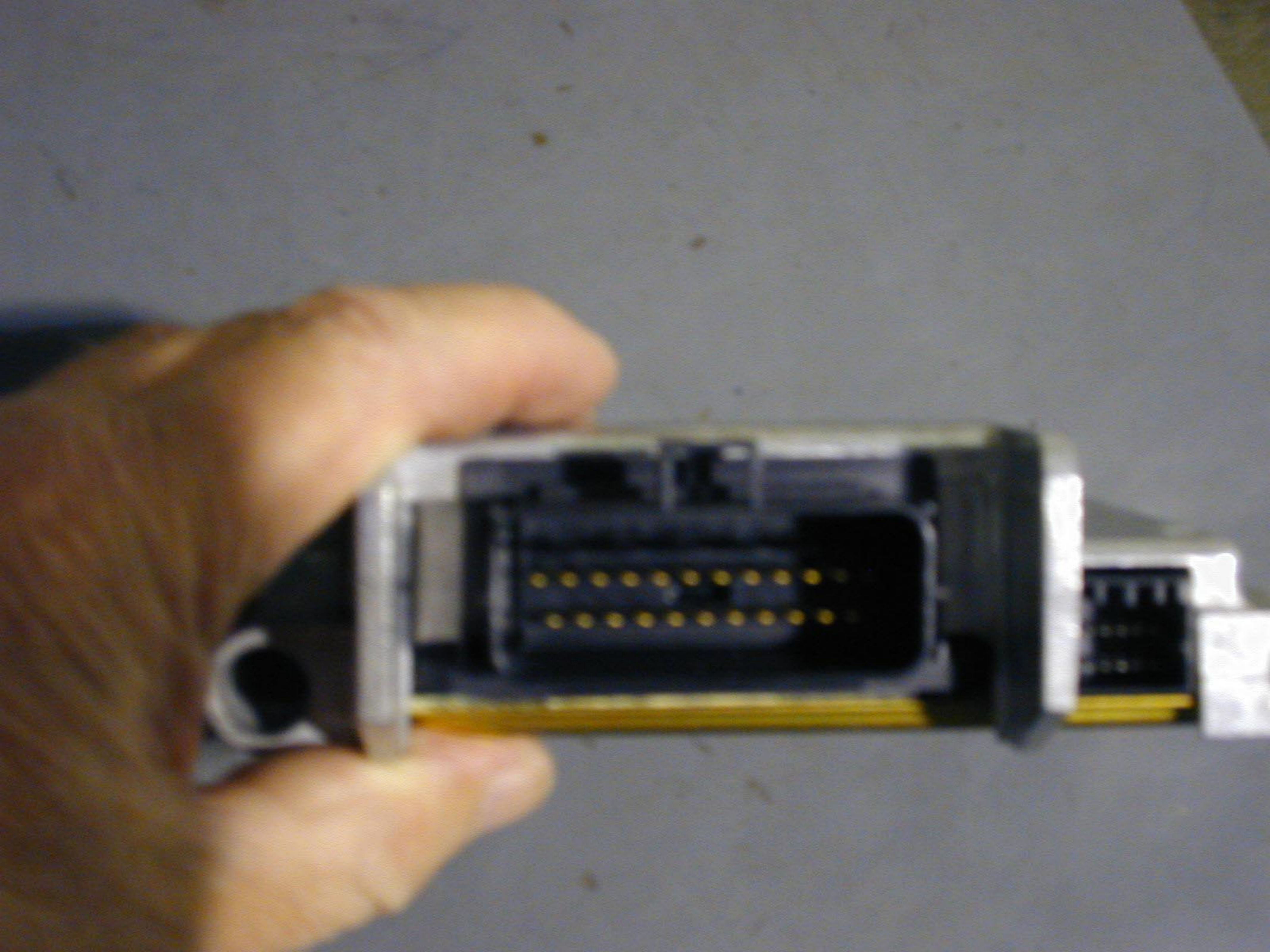

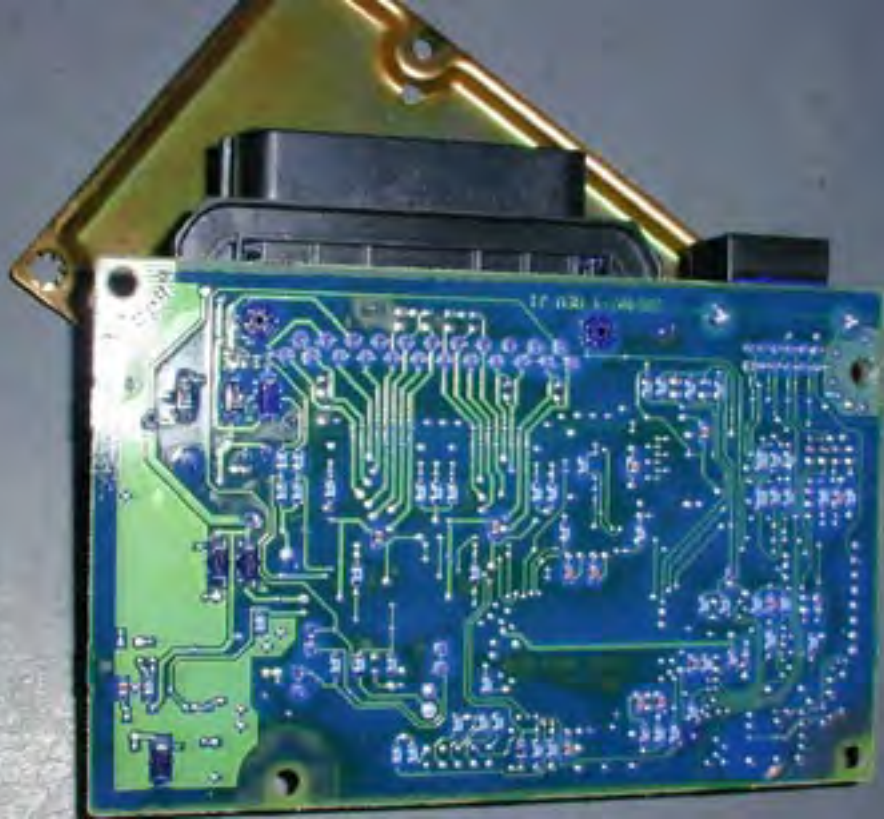

Copyright © 1998 by [unreadable]

[unreadable]

WARNING: Before using this device, read the instructions.

CAUTION: Do not use this device in the presence of flammable vapors.

For more information, contact [unreadable]

Copyright © 1998 by [unreadable]

[unreadable]



Vehicle Scan Tool

1. 3.7 3.4.7 JTEC+ 99
2. BCM_KJ
3. * MIC_KJ
4. RBK Audio

Page 1 of 1

PCM

Item 41 of 41







SAFETY
SAVINGS

WARNING





CHRYSLER PIN P5601060147



WARNING: REFER TO SERVICE MANUAL BEFORE SERVICE.

IMPROPER SERVICING CAN RESULT IN AIR BAG SYSTEM

FAILURE AND POSSIBLE DRIVER AND/OR PASSENGER INJURY.

CHRYSLER SN TRFME329E3E00112

TRFME329E3E00112

CHRYSLER SN TRFME329E3E00112

TRFME329E3E00112

TRFME329E3E00112

TRFME329E3E00112

TRFME329E3E00112

TRFME329E3E00112

TRFME329E3E00112

TRFME329E3E00112

TRFME329E3E00112

TRFME329E3E00112

TRFME329E3E00112

TRFME329E3E00112

TRFME329E3E00112

TRFME329E3E00112

MFD BY

DAIMLERCHRYSLER
CORPORATION

DATE OF MFR
12-02

GWR
2541 KG(05600 LB)

GWR FRONT

1248 KG(2750 LB)

WITH TIRES

P215/75R16

RIMS AT

16X7

COLD

227 KPA(33 PSI)

GWR REAR

1429 KG(3150 LB)

WITH TIRES

R215/75R16

RIMS AT

16X7

COLD

227 KPA(33 PSI)

THIS VEHICLE CONFORMS TO ALL APPLICABLE FEDERAL MOTOR VEHICLE SAFETY AND THEFT
PREVENTION STANDARDS IN EFFECT ON THE DATE OF MANUFACTURE SHOWN ABOVE.

VIN: 1J4GL48K73

TYPE:

MPV

SINGLE X DUAL



MDA:

120409 776AB

PNT:PB7

VEHICLE MADE IN U.S.A.

TRM:H50V

4648503





248 CDA 27W









1-800-321-COPIA
www.copa.com

PLEASE PLUG IN
ONLY WHEN
TEMPERATURE IS
BELOW -10°
WHEN YOU COME
TO WORK
THANKS!

SAFETY
SAVINGS

SAFETY
INFORMATION







EA12-001

CHRYSLER

10-4-2012

ENCLOSURE 4

FIELD DATA SUBJECT

CAIRs Backup









Jeep

Brand of Year
2008

3.7L



Jeep

David O'Neal
11111 11111 11111 11111

ERTY sport

A close-up photograph of a dark-colored car door. The door features a silver door handle with a circular keyhole. Below the handle, the text 'ERTY sport' is visible in a light-colored font. A silver trim piece runs horizontally along the bottom of the door. The car's interior, including the steering wheel and dashboard, is visible through the window. The car is parked in a garage with overhead fluorescent lights.



LIBERTY

4754

Jeep





LIBERTY sport

RE







Owner's Manual
Model: [unreadable]
Date: [unreadable]
[unreadable]

26
SW 1

cairnumber :11960954

CONFIDENTIAL - Prior Approval Required Before Duplicating**Preliminary Vehicle Investigation Report(PVIR)**

CAIR# 11960954

YEAR	BRAND	VEHICLE IDENTIFICATION NUMBER		MO/DY-HR	ODOMETER	SERVICE DATE
2002	JEEP LIBERTY SPORT 4X4 SPORT UTILITY 4-DR	1J4GL48K72W		01-08 10	28307	09/03/2002
NAME OF OWNER		ADDRESS/LOCATION		CITY	STATE	COUNTRY
				MORRISVILLE	NC	USA
ZIP	COLOR	MODEL	HOME PHONE		BUSINESS PHONE	
	Black Clear Coat	KJJ				
SELLING DEALER NAME		BUSINESS CENTER	DLR. CODE	CITY	STATE	COUNTRY
DAVID O'NEAL INC		66	67779	RALEIGH	NC	USA
INSPECTOR - NAME FIRST, LAST, MIDDLE			INSPECTOR'S COMPANY		INSPECTOR'S PHONE NO.	
Herman Montgomery B					704-488-2579	
DAMAGE ESTIMATE				REPAIR ESTIMATE		
<input checked="" type="radio"/> MINOR <input type="radio"/> MODERATE <input type="radio"/> TOTAL LOSS				\$ 2500.00		

INTERVIEWINTERVIEW WITH: DRIVER OWNER OTHER DRIVER/OWNER

NAME: LAST, FIRST, MIDDLE

INTERVIEW DATE:	DATE OF INCIDENT:	TIME OF INCIDENT	INSPECTION DATE:
01/18/2004	01/11/2004	02:00 <input type="radio"/> AM <input checked="" type="radio"/> PM	01/20/2004

1. DRIVER'S DESCRIPTION OF EVENT: **Mr. [REDACTED] stated that he was traveling down the road, coming up to a traffic light that was green. As he made a right turn at about 10 MPH, the drivers side airbag went off. He stopped the vehicle and collected his thoughts. Since he was out of town he packed the airbag back in place and drove home.**

Insurance Company Name: **State Farm**

Personal Injury: Were there Personal Injuries? Yes No

Any Indicator/Warning Lights on Prior? Yes No

If Yes, complete section "B"

If Yes, What light:

IMPORTANT: SHOW THIS REPORT TO NO ONE & ONLY STATE FACTS (DRAW NO CONCLUSIONS)

Help Key

PART A- GENERAL

REQUIRED PHOTOGRAPHS: ALL FOUR SIDE VIEWS**IF CRASH DAMAGED:**

PERSPECTIVE FROM EVERY
CORNER OF VEHICLE DOWN
BOTH ORIGINAL LATERAL
SIGHT LINES(8 TOTAL)

- ANY RECENT VEHICLE
SERVICE

YES NO

UNKNOWN

IF YES, ENCLOSE COPIES OF
REPAIR ORDERS

INFORMATION: POLICE/AGENCY REPORT #:

ALL REPORTS/PHOTOS BY
OTHERS

- ADDRESS OF INSPECTION

Address **David O'Neal Chrysler**

1

Address **5500 Capital Blvd**

2

City **Raleigh**

State **NC**

Zip **27619**

PHONE

- EVIDENCE OF TAMPERING OR PRIOR
DISASSEMBLY

YES NO

- IF YES, DESCRIBE AND PHOTOGRAPH

PART B - EXTERIOR/INTERIOR VEHICLE DAMAGE

REQUIRED PHOTOGRAPHS: **There is no physical damage to the vehicle. There is no personal injuries. The drivers side airbag deployed.**

 WINDSHIELD

ALL AREAS OF DAMAGE
MARKINGS ON INTERIOR
AND EXTERIOR

CLOSE UPS OF STAINS,
SKIN, HAIR, CLOTH

EXTERIOR AND INTERIOR
DAMAGE INCLUDING
UNDERCARRIAGE

INFORMATION:

DESCRIBE ANY INJURIES
TO DRIVER AND/OR OTHER
OCCUPANTS

SEE SEAT BELT/SEATS
SECTION IF APPLICABLE

Next

cairnumber :11960954

PART C - AIRBAG(S)

REQUIRED PHOTOGRAPHS

- STEERING WHEEL
- AIRBAG(S)
- KNEE BLOCKERS
- ALL POSSIBLE LOCATIONS OF CONTACT

AECM INFORMATION

- SOFTWARE VERSION:

- SERIAL NUMBER :
1J4GL48K72W2559
- PART NUMBER :

- DOES AIRBAG WARNING LIGHT CYCLE ON?
 YES NO N/A
- ARE WARNING LABELS PRESENT (PHOTO)
 YES NO N/A
- RECORD LABEL PART NUMBER

COMPLETE PART D

- PHOTOGRAPH REQUIRED FOR DRB SCREENS & RECORD FAULTS
- WERE THERE DRB READINGS TAKEN?

YES NO IF NO, EXPLAIN **The code read,unable to ID Module.**

- RECORD ACTIVE DTC'S EXACTLY AS APPEAR :	MIN	COUNT
Unable to ID Module		
- RECORD STORED DTC'S (MINUTES/COUNTS) :	MIN	COUNT

- WAS AIRBAG DEPLOYED?

DRIVER YES NO

IF NO, EXPLAIN

PASSENGER YES NO

IF NO, EXPLAIN

Did not deploy

SIDE AIRBAG YES NO N/A

IF NO, EXPLAIN

- WHICH SIDE DEPLOYED?

LEFT RIGHT N/A

BOTH

- TYPE OF SIDE AIRBAG

SEAT CURTAIN N/A

- TYPE OF STEERING WHEEL

TILT STANDARD

- ANY DAMAGE TO STEERING WHEEL

YES NO
IF YES, EXPLAIN

DO NOT ERASE DRB READINGS

IS VEHICLE EQUIPPED WITH PASSENGER AIRBAG DEFAULT SWITCH?

YES NO

IF YES,

NOTE POSITION OF PASSENGER A/B SWITCH

ON OFF N/A

- EVIDENCE OF TAMPERING OR DISASSEMBLY?

YES NO N/A

IF YES, EXPLAIN

CHECK ENTIRE UNDERBODY FOR HIDDEN DAMAGE INCLUDING FRONT AND REAR SUSPENSION COMPONENTS

- UNDERBODY DAMAGED?

YES NO
IF YES, EXPLAIN

PHOTOGRAPH REQUIRED

PART D - SEATS/SHOULDER BELTS

REQUIRED PHOTOGRAPHS:

- OVERALL SEAT BELTS I/B & O/B
- CLOSE UP OF ANY IRREGULARITIES
- LATCHPLATE WEAR
- CLOSE UP D-RING TO SHOW LOADING
- OVERALL OF SEAT
- CLOSE UP OF DAMAGE
- RECORD DTC'S:

INFORMATION:

- LOCATE SEAT BELT LABELS AND RECORD ALL INFORMATION (SOME LABELS ARE SEWN TO WEBBING, OTHER LABELS ARE ON THE RETRACTOR FRAME: INBOARD SEAT BELT LABELS ARE NEAR THE FLOOR):

left front-TD049,Right front-T0049,Left rear-TC217,Right rear-TC226.

- RECORD ALL INFORMATION STAMPED ON LATCHPLATE

- PRETENSION DEPLOYED?

YES NO UNKNOWN

- EXISTING LOCATION OF RECLINER - DESCRIBE THE LOCATION AND PICTURE OF SEAT BACK WITH B PILLOR AS REFERENCE AND INCLINOMETER READING

EXISTING LOCATION OF HEAD RESTRAINT (MEASURE GAP UNDER HEAD RESTRAINT):

IF ALLOWED. FUNCTION BELTS TO INSURE THEY **FUNCTION PROPERLY**

NOTE RESULTS

- DOES THE BUCKLE LATCH?

YES NO

IF NO, EXPLAIN

- DO THEY RELEASE?

YES NO

IF NO, EXPLAIN

- DO THEY RETRACT?

YES NO

IF NO, EXPLAIN

- ANY LOOSENESS OR BROKEN PARTS

YES NO

IF YES, EXPLAIN?

- CHECK FOR SEAT RETAINING BOLTS

NORMAL

BROKEN

LOOSE

MISSING

- NOTE AND RECORD APPROX. SEAT TRACK OVERLAP

PART - E TRANSMISSION NOT APPLICABLE

[Previous](#)

[Next](#)

PART - F UNINTENDED ACCELERATION NOT APPLICABLE

PART - G BRAKES NOT APPLICABLE

PART - H STEERING/SUSPENSION/TIRES NOT APPLICABLE

PART - I AXLE/DIFFERENTIAL NOT APPLICABLE

 PART J - ADDITIONAL COMMENTS (DO NOT DRAW ANY CONCLUSIONS)

The spare tire on the vehicle had a four inch cut in it but the owner states it did not come off the front of the vehicle.I inspected the vehicle completely and could find no physical damage.The front wheels were removed and no damage to the brakes.

Previous

EA12-001

CHRYSLER

10-4-2012

ENCLOSURE 4

FIELD DATA SUBJECT

CAIRs Backup

From: [REDACTED]
To: customerassist@daimlerchrysler.com
Date: Sat Jan 17 18:15:34 EST 2004
Subject: DaimlerChrysler Customer Assistance
Form Selected:

Category: US Customer Service
Brief Description:

Air bag deployed when vehicle was unoccupied and stationary
Comments:

I was standing 20 feet from the parked vehicle - heard a bang - looked up
and the airbag had deployed. Vehicle was parked and idling.

Should I
contact NTSB?

Sender Information:

Title: Dr.
First Name: [REDACTED]
Middle Initial: [REDACTED]
Last Name: [REDACTED]

From: [REDACTED] Postmaster@wkamerica.notes.chrysler.com
To: customerassist@daimlerchrysler.com
Date: Sat Jan 17 18:21:17 EST 2004
Subject: DELIVERY FAILURE: host mailin.scccd.com[10.10.10.7] said: 550
[REDACTED]: Userunknown (in reply to RCPT TO command)
This is the Postfix program at host smtp-relay1.scccd.com.

I'm sorry to have to inform you that the message returned below could not be delivered to one or more destinations.

For further assistance, please send mail to <postmaster>

If you do so, please include this problem report. You can delete your own text from the message returned below.

The Postfix program

[REDACTED] mailin.scccd.com[10.10.10.7] said:
[REDACTED] User unknown (in reply to RCPT
TO command)

[Attachment 1.2 Type: message/delivery-status][Forwarded message displayed below]

Final-Recipient: rfc822; [REDACTED]
Action: failed
Status: 5.0.0
Diagnostic-Code: X-Postfix; host mailin.scccd.com[10.10.10.7] said: 550
[REDACTED] User unknown (in reply to RCPT TO
command)

[End of Forwarded Message 1]

[Attachment 1.1 Type: message/rfc822][Forwarded message displayed below]

Date: Sat, 17 Jan 2004 18:18:08 -0500
Subject: DaimlerChrysler Customer Assistance Center (KMM697326V81440L0KM)
From: customerassist <customerassist@daimlerchrysler.com>
Reply-To: customerassist <customerassist@daimlerchrysler.com>

*****AUTOMATED RESPONSE - DO NOT REPLY TO THIS ADDRESS *****

Thank you for your email inquiry. Your question has been sent to the DaimlerChrysler Customer Assistance Center in order to provide the best answer for your Chrysler, Dodge, or Jeep question. Every effort will be made to respond to your email within 3 business days.

While waiting for our response, feel free to visit our brand web sites at <http://www.chrysler.com>, <http://www.dodge.com> or <http://www.jeep.com>. These sites may provide the information you have requested.

NOTE: This is an automatically generated response. Our system is NOT able to accept email at this address. Please do not use the 'Reply' function of your email.

If this matter is urgent, please call us at 800.992.1997 (8:00 a.m. to

5:00 p.m., Monday thru Friday).

For ALL future communications (related to this email), please refer to the following information:

REFERENCE NUMBER: 11983584

[End of Forwarded Message 1]

From: [REDACTED]
To: customerassist@daimlerchrysler.com
Date: Fri Jan 23 10:25:14 EST 2004
Subject: DELIVERY FAILURE: host mailin.scccd.com[10.10.10.7] said: 550
<carljohansson@fresnocitycollege.edu>: Userunknown (in reply to RCPT TO command)
This is the Postfix program at host smtp-relay1.scccd.com.

I'm sorry to have to inform you that the message returned below could not be delivered to one or more destinations.

For further assistance, please send mail to <postmaster>

If you do so, please include this problem report. You can delete your own text from the message returned below.

The Postfix program

<[REDACTED]@mailin.scccd.com[10.10.10.7] said:
User unknown (in reply to RCPT
TO command)

[Attachment 1.2 Type: message/delivery-status][Forwarded message displayed below]

Final-Recipient: rfc822; [REDACTED]
Action: failed
Status: 5.0.0
Diagnostic-Code: X-Postfix: host mailin.scccd.com[10.10.10.7] said: 550
[REDACTED] User unknown (in reply to RCPT TO
command)

[End of Forwarded Message 1]

[Attachment 1.1 Type: message/rfc822][Forwarded message displayed below]

Date: Fri, 23 Jan 2004 10:22:52 -0500
Subject: Re: DaimlerChrysler Customer Assistance (KMM711764V71153L0KM)
From: customerassist <customerassist@daimlerchrysler.com>
Reply-To: customerassist <customerassist@daimlerchrysler.com>

Dear [REDACTED]

Thank you again for your email to DaimlerChrysler regarding your Liberty.

A review of our records indicate that the following recall campaign(s) have not been performed by an authorized DaimlerChrysler dealer.

Recall # C36 - LOWER BALL JOINTS

Since we can't always confirm that the needed service has been performed, we ask that you contact your local authorized Jeep dealer to make arrangements for an inspection and, if necessary, corrective action at no charge to you.

Thank you again for writing.

NOTE: Please do not use the 'Reply' function of your email system. If you have a need to respond to this message, please visit us at our reply form (link provided below). Our system is NOT able to accept any emails at this address.

For any future communications related to this email, please refer to the following information:

REFERENCE NUMBER:

REPLY LINK:

http://www.chrysler.com/wccsapp/wccs/brand_forms/us/reply.jsp?trk_ID=KMM711764C0KM&

Sincerely,

Laura
Senior Staff Representative
DaimlerChrysler Customer Assistance Center

Previous Reply Follows:

Dear Carl:

Your email concerning your air bag incident was received and reviewed by the DaimlerChrysler Customer Assistance Center.

We were sorry to learn of the incident, and understand your being upset over it. If you haven't already done so, it is recommended that you contact your insurance company and advise them of the occurrence.

These types of issues are handled on a personal basis, over the telephone. Please contact our Customer Assistance Center at 1-800-992-1997 so that we may discuss this matter with you.

The Agent will be gathering some critical information concerning the incident, and your vehicle, for further investigation. Some of this information will be: the date of the incident; the place; detailed information about the incident; where the vehicle is currently; the vehicle identification number of your vehicle; and other pertinent information.

Our Agent will then advise you concerning further actions.

Thank you again for writing.

NOTE: Please do not use the 'Reply' function of your email system. If you have a need to respond to this message, please visit us at our reply form (link provided below). Our system is NOT able to accept any emails at this address.

For any future communications related to this email, please refer to the following information:

REFERENCE NUMBER: 11983584

REPLY LINK:

http://www.chrysler.com/wccsapp/wccs/brand_forms/us/reply.jsp?trk_ID=KMM711724C0KM&

Sincerely,

Laura
Senior Staff Representative
DaimlerChrysler Customer Assistance Center

Original Message Follows:

Form Selected:

Category: US Customer Service

Brief Description:

Air bag deployed when vehicle was unoccupied and stationary

Comments:

I was standing 20 feet from the parked vehicle - heard a bang - looked
up
and the airbag had deployed. Vehicle was parked and idling.

Should I
contact NTSB?

Sender Information:

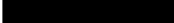
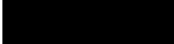
Title: Dr.
First Name: 
Middle Initial: 
Last Name: 

[End of Forwarded Message 1]

From: customerassist@daimlerchrysler.com
To: [REDACTED]
Date: Fri Jan 23 10:19:13 EST 2004
Subject: Re: DaimlerChrysler Customer Assistance
Dear [REDACTED]

Thank you again for your email to DaimlerChrysler regarding your Liberty.

A review of our records indicate that the following recall campaign(s) have not been performed by an authorized DaimlerChrysler dealer.

Recall # C36 - LOWER BALL JOINTS

Since we can't always confirm that the needed service has been performed, we ask that you contact your local authorized Jeep dealer to make arrangements for an inspection and, if necessary, corrective action at no charge to you.

Thank you again for writing.

NOTE: Please do not use the 'Reply' function of your email system. If you have a need to respond to this message, please visit us at our reply form (link provided below). Our system is NOT able to accept any emails at this address.

For any future communications related to this email, please refer to the following information:

REFERENCE NUMBER:

REPLY LINK:

http://www.chrysler.com/wccsapp/wccs/brand_forms/us/reply.jsp?trk_ID=KMM711764C0KM&

Sincerely,

Laura
Senior Staff Representative
DaimlerChrysler Customer Assistance Center

Previous Reply Follows:

Dear [REDACTED]

Your email concerning your air bag incident was received and reviewed by the DaimlerChrysler Customer Assistance Center.

We were sorry to learn of the incident, and understand your being upset over it. If you haven't already done so, it is recommended that you contact your insurance company and advise them of the occurrence.

These types of issues are handled on a personal basis, over the telephone. Please contact our Customer Assistance Center at 1-800-992-1997 so that we may discuss this matter with you.

The Agent will be gathering some critical information concerning the incident, and your vehicle, for further investigation. Some of this information will be: the date of the incident; the place; detailed information about the incident; where the vehicle is currently; the vehicle identification number of your vehicle; and other pertinent information.

Our Agent will then advise you concerning further actions.

Thank you again for writing.

NOTE: Please do not use the 'Reply' function of your email system. If you have a need to respond to this message, please visit us at our reply form (link provided below). Our system is NOT able to accept any emails at this address.

For any future communications related to this email, please refer to the following information:

REFERENCE NUMBER: 11983584

REPLY LINK:

http://www.chrysler.com/wccsapp/wccs/brand_forms/us/reply.jsp?trk_ID=KMM711724C0KM&

Sincerely,

Laura
Senior Staff Representative
DaimlerChrysler Customer Assistance Center

Original Message Follows:

Form Selected:

Category: US Customer Service

Brief Description:

Air bag deployed when vehicle was unoccupied and stationary

Comments:

I was standing 20 feet from the parked vehicle - heard a bang - looked up and the airbag had deployed. Vehicle was parked and idleing.

Should I
contact NTSB?

Sender Information:

Title: Dr
First Name
Middle Initial
Last Name

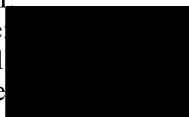

From: [REDACTED]
To: customerassist@daimlerchrysler.com
Date: Fri Jan 23 10:19:38 EST 2004
Subject: DELIVERY FAILURE: host mailin.scccd.com[10.10.10.7] said: 550
[REDACTED]: Userunknown (in reply to RCPT TO command)
This is the Postfix program at host smtp-relay1.scccd.com.

I'm sorry to have to inform you that the message returned below could not be delivered to one or more destinations.

For further assistance, please send mail to <postmaster>

If you do so, please include this problem report. You can delete your own text from the message returned below.

The Postfix program

<[REDACTED]@mailin.scccd.com[10.10.10.7] said:
[REDACTED] User unknown (in reply to RCPT
TO command)

[Attachment 1.2 Type: message/delivery-status][Forwarded message displayed below]

Final-Recipient: rfc822; carljohansson@fresnocitycollege.edu
Action: failed
Status: 5.0.0
Diagnostic-Code: X-Postfix; host mailin.scccd.com[10.10.10.7] said: 550
[REDACTED] User unknown (in reply to RCPT TO
command)

[End of Forwarded Message 1]

[Attachment 1.1 Type: message/rfc822][Forwarded message displayed below]

Date: Fri, 23 Jan 2004 10:17:41 -0500
Subject: Re: DaimlerChrysler Customer Assistance (KMM711724V70271L0KM)
From: customerassist <customerassist@daimlerchrysler.com>
Reply-To: customerassist <customerassist@daimlerchrysler.com>

Dear [REDACTED]

Your email concerning your air bag incident was received and reviewed by the DaimlerChrysler Customer Assistance Center.

We were sorry to learn of the incident, and understand your being upset over it. If you haven't already done so, it is recommended that you contact your insurance company and advise them of the occurrence.

These types of issues are handled on a personal basis, over the telephone. Please contact our Customer Assistance Center at 1-800-992-1997 so that we may discuss this matter with you.

The Agent will be gathering some critical information concerning the incident, and your vehicle, for further investigation. Some of this information will be: the date of the incident; the place; detailed

information about the incident; where the vehicle is currently; the vehicle identification number of your vehicle; and other pertinent information.

Our Agent will then advise you concerning further actions.

Thank you again for writing.

NOTE: Please do not use the 'Reply' function of your email system. If you have a need to respond to this message, please visit us at our reply form (link provided below). Our system is NOT able to accept any emails at this address.

For any future communications related to this email, please refer to the following information:

REFERENCE NUMBER: 11983584

REPLY LINK:

http://www.chrysler.com/wccsapp/wccs/brand_forms/us/reply.jsp?trk_ID=KMM711724C0KM&

Sincerely,

Laura
Senior Staff Representative
DaimlerChrysler Customer Assistance Center

Original Message Follows:

Form Selected:

Category: US Customer Service

Brief Description:



Air bag deployed when vehicle was unoccupied and stationary

Comments:

I was standing 20 feet from the parked vehicle - heard a bang - looked up and the airbag had deployed. Vehicle was parked and idleing.

Should I
contact NTSB?

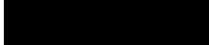
Sender Information:

Title: Dr.
First Name: 
Middle Initial: 
Last Name: 

[End of Forwarded Message 1]

From: customerassist@daimlerchrysler.com
To: [REDACTED]
Date: Fri Jan 23 10:04:31 EST 2004
Subject: Re: DaimlerChrysler Customer Assistance
Dear [REDACTED]

Your email concerning your air bag incident was received and reviewed by the DaimlerChrysler Customer Assistance Center.

We were sorry to learn of the incident, and understand your being upset over it. If you haven't already done so, it is recommended that you contact your insurance company and advise them of the occurrence.

These types of issues are handled on a personal basis, over the telephone. Please contact our Customer Assistance Center at 1-800-992-1997 so that we may discuss this matter with you.

The Agent will be gathering some critical information concerning the incident, and your vehicle, for further investigation. Some of this information will be: the date of the incident; the place; detailed information about the incident; where the vehicle is currently; the vehicle identification number of your vehicle; and other pertinent information.

Our Agent will then advise you concerning further actions.

Thank you again for writing.

NOTE: Please do not use the 'Reply' function of your email system. If you have a need to respond to this message, please visit us at our reply form (link provided below). Our system is NOT able to accept any emails at this address.

For any future communications related to this email, please refer to the following information:

REFERENCE NUMBER: 11983584

REPLY LINK:

http://www.chrysler.com/wccsapp/wccs/brand_forms/us/reply.jsp?trk_ID=KMM711724C0KM&

Sincerely,

Laura
Senior Staff Representative
DaimlerChrysler Customer Assistance Center

Original Message Follows:

Form Selected:

Category: US Customer Service

Brief Description:

Air bag deployed when vehicle was unoccupied and stationary

Comments:

I was standing 20 feet from the parked vehicle - heard a bang - looked up and the airbag had deployed. Vehicle was parked and idling.

Should I
contact NTSB?

Sender Information:

Title: Dr.

First Name:

Middle Initial:

Last Name:



EA12-001

CHRYSLER

10-4-2012

ENCLOSURE 4

FIELD DATA SUBJECT

CAIRs Backup



9989

Jeep









Jeep

3.7L

WRANGLER SUV
GOODYEAR







9989

LIBERTY 4x4

LIBERTY

MFD BY DAIMLERCHRYSLER CORPORATION

DATE OF MFR 10-01

GVWR 2541 KG (05600 LB)

GVWR FRONT WITH TIRES 1730 KG (2600 LB) P215/75SR16

RIMS AT 16X7

COLD

GVWR REAR WITH TIRES 1429 KG (3150 LB) P215/75SR16

RIMS AT 16X7

227 KPA (33 PSI)

COLD

227 KPA (33 PSI)

THIS VEHICLE CONFORMS TO ALL APPLICABLE FEDERAL MOTOR VEHICLE SAFETY AND THEFT PREVENTION STANDARDS IN EFFECT ON THE DATE OF MANUFACTURE SHOWN ABOVE.

VIN: 1J4GL48K52W [REDACTED]

TYPE: MPV

SINGLE X DUAL



MDH: 101602 387AA PNT:PR4

VEHICLE MADE IN U.S.A. TRM:MSDU 4648503















A WARNING
DEATH OR SERIOUS INJURY CAN OCCUR



989

WARNING



BEWAKUKAN KESELAMATAN
MELAKUKAKAN PERKALAN

WARNING



PERINGATAN
DILAKUKAN PERKALAN

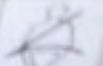

990





060702

















BFGoodrich

All-Terrain T/A







0000000000
0000000000











IB/CK





CHRISTMAS

12V

12V

12V

12V

12V

12V

12V

12V

12V

12V

12V

12V

12V

12V

12V

12V

12V

12V



CHRYSLER P/N P56010501AE

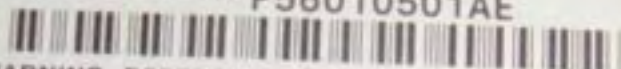

WARNING. REFER TO SERVICE MANUAL BEFORE SERVICING.
IMPROPER SERVICING CAN RESULT IN AIR BAG SYSTEM
FAILURE AND POSSIBLE DRIVER AND/OR PASSENGER INJURY.

CHRYSLER S/N TSFME2811A7513

SUPPLIER CODE

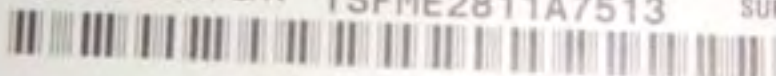

39754C

From: [REDACTED]
To: customerassist@daimlerchrysler.com
Date: Tue Jan 20 13:12:58 EST 2004
Subject: DaimlerChrysler Customer Assistance
Form Selected:

Category: US Customer Service
Brief Description:

Airbag deployment in parked vehicle
Comments:

I parked the vehicle at the side of the road - got out to talk with a neighbor - we heard a bang and both airbags had deployed . Vehicle was stationary engine was idleing.

Sender Information:

Title: Dr.
First Name: [REDACTED]
Middle Initial: [REDACTED]
Last Name: [REDACTED]

cairnumber :11991929

CONFIDENTIAL - Prior Approval Required Before Duplicating**Preliminary Vehicle Investigation Report(PVIR)**

CAIR# 11991929

YEAR	BRAND	VEHICLE IDENTIFICATION NUMBER		MO/DY-HR	ODOMETER	SERVICE DATE
2002	JEEP LIBERTY SPORT 4X4 SPORT UTILITY 4-DR	1J4GL48K52W [REDACTED]		10-16 02	60702	03/28/2002
NAME OF OWNER		ADDRESS/LOCATION		CITY	STATE	COUNTRY
[REDACTED]		[REDACTED]		AUBERRY	CA	USA
ZIP	COLOR	MODEL	HOME PHONE		BUSINESS PHONE	
[REDACTED]	Flame Red Clear Coat	KJJ	[REDACTED]		[REDACTED]	
SELLING DEALER NAME		BUSINESS CENTER	DLR. CODE	CITY	STATE	COUNTRY
SURROZ DODGE-CHRY-JEEP		71	43921	VISALIA	CA	USA
INSPECTOR - NAME FIRST, LAST, MIDDLE			INSPECTOR'S COMPANY		INSPECTOR'S PHONE NO.	
Hank Machado			SPX-E.A.A.		408-778-9555	
DAMAGE ESTIMATE				REPAIR ESTIMATE		
<input type="radio"/> MINOR <input checked="" type="radio"/> MODERATE <input type="radio"/> TOTAL LOSS				\$ 2500.00		

INTERVIEW

INTERVIEW WITH:

 DRIVER
 OWNER
 OTHER
 DRIVER/OWNER

NAME: LAST, FIRST, MIDDLE

[REDACTED]

INTERVIEW DATE:

DATE OF INCIDENT:

TIME OF INCIDENT

INSPECTION DATE:

01/22/2004**01/18/2004****00:01** AM PM**01/22/2004**

1. DRIVER'S DESCRIPTION OF EVENT: **Driver advises he had parked the vehicle and left the engine running. He got out of the vehicle and heard the airbags deploy.**

Insurance

Company

Farmers

Name:

Personal Injury:

Were there

Personal

 Yes No

If Yes, complete section "B"

Injuries?

Any Indicator/

Warning Lights

 Yes No

If Yes, What light:

on Prior?

IMPORTANT: SHOW THIS REPORT TO NO ONE & ONLY STATE FACTS (DRAW NO CONCLUSIONS)

Help Key

PART A- GENERAL

REQUIRED PHOTOGRAPHS:

- ALL FOUR SIDE VIEWS
- IF CRASH DAMAGED:**
- PERSPECTIVE FROM EVERY CORNER OF VEHICLE DOWN BOTH ORIGINAL LATERAL SIGHT LINES(8 TOTAL)
- ANY RECENT VEHICLE SERVICE

YES NO

UNKNOWN

IF YES, ENCLOSE COPIES OF REPAIR ORDERS

INFORMATION:

POLICE/AGENCY REPORT #:

None

ALL REPORTS/PHOTOS BY OTHERS

- ADDRESS OF INSPECTION

Address **Fresno C-J**

1

Address **4880 Blackstone**

2

City **Fresno**

State **CA**

Zip **93726**

PHONE

- EVIDENCE OF TAMPERING OR PRIOR DISASSEMBLY

YES NO

- IF YES, DESCRIBE AND PHOTOGRAPH

PART B - EXTERIOR/INTERIOR VEHICLE DAMAGE

REQUIRED PHOTOGRAPHS:

- WINDSHIELD
- ALL AREAS OF DAMAGE MARKINGS ON INTERIOR AND EXTERIOR
- CLOSE UPS OF STAINS, SKIN, HAIR, CLOTH
- EXTERIOR AND INTERIOR DAMAGE INCLUDING UNDERCARRIAGE

Windshield is cracked from rock chips. The vehicle was not occupied when airbags deployed. There were no injuries involved with this incident.

INFORMATION:

- DESCRIBE ANY INJURIES TO DRIVER AND/OR OTHER OCCUPANTS
 - SEE SEAT BELT/SEATS SECTION IF APPLICABLE
-
-

Next

cairnumber :11991929

PART C - AIRBAG(S)

REQUIRED PHOTOGRAPHS

- STEERING WHEEL
- AIRBAG(S)
- KNEE BLOCKERS
- ALL POSSIBLE LOCATIONS OF CONTACT

AECM INFORMATION

- SOFTWARE VERSION:

NO RESPONSE

- SERIAL NUMBER :

TSFME2811A7513

- PART NUMBER :

P56010501AE

- DOES AIRBAG WARNING LIGHT CYCLE ON?

YES NO N/A

- ARE WARNING LABELS PRESENT (PHOTO)

YES NO N/A

- RECORD LABEL PART NUMBER

NONE

COMPLETE PART D

- PHOTOGRAPH REQUIRED FOR DRB SCREENS & RECORD FAULTS
- WERE THERE DRB READINGS TAKEN?

YES NO IF NO, EXPLAIN

NO RESPONSE FROM SRS SYSTEM

- RECORD ACTIVE DTC'S EXACTLY AS APPEAR :	MIN	COUNT
DRB III HAS NO RESPONSE FROM SRS CONTROLLER		
- RECORD STORED DTC'S (MINUTES/COUNTS) :	MIN	COUNT
UNABLE TO OBTAIN ANY INFO WITH DRB III FROM CONTROLLER		

- WAS AIRBAG DEPLOYED?

DRIVER YES NO

IF NO, EXPLAIN

PASSENGER YES NO

IF NO, EXPLAIN

SIDE AIRBAG YES NO N/A

IF NO, EXPLAIN

- WHICH SIDE DEPLOYED?

LEFT RIGHT N/A

BOTH

- TYPE OF SIDE AIRBAG

SEAT CURTAIN N/A

- TYPE OF STEERING WHEEL

TILT STANDARD

- ANY DAMAGE TO STEERING WHEEL

YES NO

IF YES, EXPLAIN

DO NOT ERASE DRB READINGS

IS VEHICLE EQUIPPED WITH PASSENGER AIRBAG DEFAULT SWITCH?

YES NO

IF YES,

NOTE POSITION OF PASSENGER A/B SWITCH

ON OFF N/A

- EVIDENCE OF TAMPERING OR DISASSEMBLY?

YES NO N/A

IF YES, EXPLAIN

CHECK ENTIRE UNDERBODY FOR HIDDEN DAMAGE INCLUDING FRONT AND REAR SUSPENSION COMPONENTS

- UNDERBODY DAMAGED?

YES NO

IF YES, EXPLAIN

PHOTOGRAPH REQUIRED

PART D - SEATS/SHOULDER BELTS

REQUIRED PHOTOGRAPHS:

- OVERALL SEAT BELTS I/B & O/B
- CLOSE UP OF ANY IRREGULARITIES
- LATCHPLATE WEAR
- CLOSE UP D-RING TO SHOW LOADING
- OVERALL OF SEAT
- CLOSE UP OF DAMAGE
- RECORD DTC'S:

INFORMATION:

- LOCATE SEAT BELT LABELS AND RECORD ALL INFORMATION (SOME LABELS ARE SEWN TO WEBBING, OTHER LABELS ARE ON THE RETRACTOR FRAME: INBOARD SEAT BELT LABELS ARE NEAR THE FLOOR):

VEHICLE NOT OCCUPIED

- RECORD ALL INFORMATION STAMPED ON LATCHPLATE

VEHICLE NOT OCCUPIED

- PRETENSION DEPLOYED?

YES NO UNKNOWN

- EXISTING LOCATION OF RECLINER - DESCRIBE THE LOCATION AND PICTURE OF SEAT BACK WITH B PILLOR AS REFERENCE AND INCLINOMETER READING

VEHICLE NOT OCCUPIED

EXISTING LOCATION OF HEAD RESTRAINT (MEASURE GAP UNDER HEAD RESTRAINT):

IF ALLOWED. FUNCTION BELTS TO INSURE THEY **FUNCTION PROPERLY**

NOTE RESULTS

- DOES THE BUCKLE LATCH?

YES NO

IF NO, EXPLAIN

- DO THEY RELEASE?

YES NO

IF NO, EXPLAIN

- DO THEY RETRACT?

YES NO

IF NO, EXPLAIN

- ANY LOOSENESS OR BROKEN PARTS

YES NO

IF YES, EXPLAIN?

- CHECK FOR SEAT RETAINING BOLTS

NORMAL

BROKEN

LOOSE

MISSING

MISSING
NOTE AND RECORD APPROX. SEAT TRACK
OVERLAP
VEHICLE NOT OCCUPIED

PART - E TRANSMISSION NOT APPLICABLE

Previous

Next

PART - F UNINTENDED ACCELERATION NOT APPLICABLE

PART - G BRAKES NOT APPLICABLE

PART - H STEERING/SUSPENSION/TIRES NOT APPLICABLE

PART - I AXLE/DIFFERENTIAL NOT APPLICABLE

PART J - ADDITIONAL COMMENTS (DO NOT DRAW ANY CONCLUSIONS)

THE DRB III IS UNABLE TO COMMUNICATE WITH THE AIRBAG MODULE. AIRBAGS DEPLOYED WHEN THE VEHICLE WAS PARKED WITH THE ENGINE RUNNING.THERE WERE NO OCCUPANTS IN THE VEHICLE AT THE TIME. THERE IS NO DAMAGE TO THE VEHICLE.INSPECTOR WAS UNABLE TO DETERMINE WHY AIRBAGS DEPLOYED.

Previous

From: customerassist@daimlerchrysler.com
To: [REDACTED]
Date: Mon Jan 26 16:31:23 EST 2004
Subject: Re: DaimlerChrysler Customer Assistance
Dear [REDACTED]

Thank you for your email to DaimlerChrysler regarding your 2002 Jeep Liberty.

Our records show that you have contacted us by telephone and are addressing your concerns. We have updated your file to reflect the latest information you provided in the email message.

If your concerns have not been addressed, or you have other concerns, please email or contact the DaimlerChrysler Customer Assistance Center by telephone at 1-800-992-1997, 8:00 a.m. to 5:00 p.m., Monday through Friday.

Thank you again for your email.

NOTE: Please do not use the 'Reply' function of your email system. If you have a need to respond to this message, please visit us at our reply form (link provided below). Our system is NOT able to accept any emails at this address.

For any future communications related to this email, please refer to the following information:

REFERENCE NUMBER: 11991929

REPLY LINK:

http://www.chrysler.com/wccsapp/wccs/brand_forms/us/reply.jsp?trk_ID=KMM717798C0KM&

Sincerely,

Nicole
Senior Staff Representative
DaimlerChrysler Customer Assistance Center

Original Message Follows:

Form Selected:

Category: US Customer Service

Brief Description:

Airbag deployment in parked vehicle

Comments:

I parked the vehicle at the side of the road - got out to talk with a neighbor - we heard a bang and both airbags had deployed . Vehicle was stationary engine was idleing.

Sender Information:

Title: Dr.
First Name: [REDACTED]
Middle Initial: [REDACTED]
Last Name: [REDACTED]

EA12-001

CHRYSLER

10-4-2012

ENCLOSURE 4

FIELD DATA SUBJECT

CAIRs Backup

MFD BY DAIMLERCHRYSLER CORPORATION DATE OF MFR 3-03 GVWR 2427 KG(05350 LB)

GVWR FRONT	WITH TIRES	RIMS AT	COLD
1248 KG(2750 LB)	P215/75R16	16X7	227 KPA(33 PSI)
GVWR REAR	WITH TIRES	RIMS AT	COLD
1429 KG(3150 LB)	R215/75R16	16X7	227 KPA(33 PSI)

THIS VEHICLE CONFORMS TO ALL APPLICABLE FEDERAL MOTOR VEHICLE SAFETY AND THEFT PREVENTION STANDARDS IN EFFECT ON THE DATE OF MANUFACTURE SHOWN ABOVE.

VIN: 1J4GK48K63 [REDACTED] TYPE: MPV SINGLE X DUAL



KDH: 030413 978AA PNT:PRV VEHICLE MADE IN U.S.A. TRM:KSL5 4648503



AIR BAG



BRAKE

008091

Before operating, carefully read the
DRIII Software License Agreement
provided with the original software and
DRIII or with any other updates
provided updates to the software.
The DRIII Software License Agreement
can also be viewed at the following
<http://www.williams.com>
or contact Williams Global Inc.
in the US: 1-800-888-5428
Press YES
If you agree to be bound by the terms
of that license agreement.

F1 F2 F3 F4

ENTER

8091
1608
W125

63w0644118
w0066020

Main Menu
1. Connect to TechCONNECT
2. Connect to TechCONNECT
3. Generic Scan Tool
4. PIP Module Tools
5. Run Memory Card Programs
6. DRB Utilities
Vehicle Flash
Legacy KMS1 Support
Page 1 of 1
HELP

F1 F2 F3 F4

8091
111505

3w6 44118

are 60.0

DRE-III CORB Application
DaimlerChrysler
Copyright © 1993-2004
All Rights Reserved
RELEASE: 68.0.01

Released: 11:22:27 5/21/2004
Bios Version: 4.07
Database: 15:23:16 5/20/2004
Cable in use: J1962 (CI70000)

HELP

0.0

F1 F2 F3 F4

↑ ↓

8091
M106

163w644118

WAVE 607

1998 - 2005 DIAGNOSTICS
1. 01 - 05 Stratus/Sebring Coupe
2. 96 - 00 Buenger/Sebring Coupe
3. 1998 Talon
4. 2000 - 2005 Crossfire
5. 2003 - 2004 Sprinter

Page 1 of 1
HELP B78 H00

8091
MI 465
163w64418
w npe 60.0

F1 F2 F3 F4

ENTER

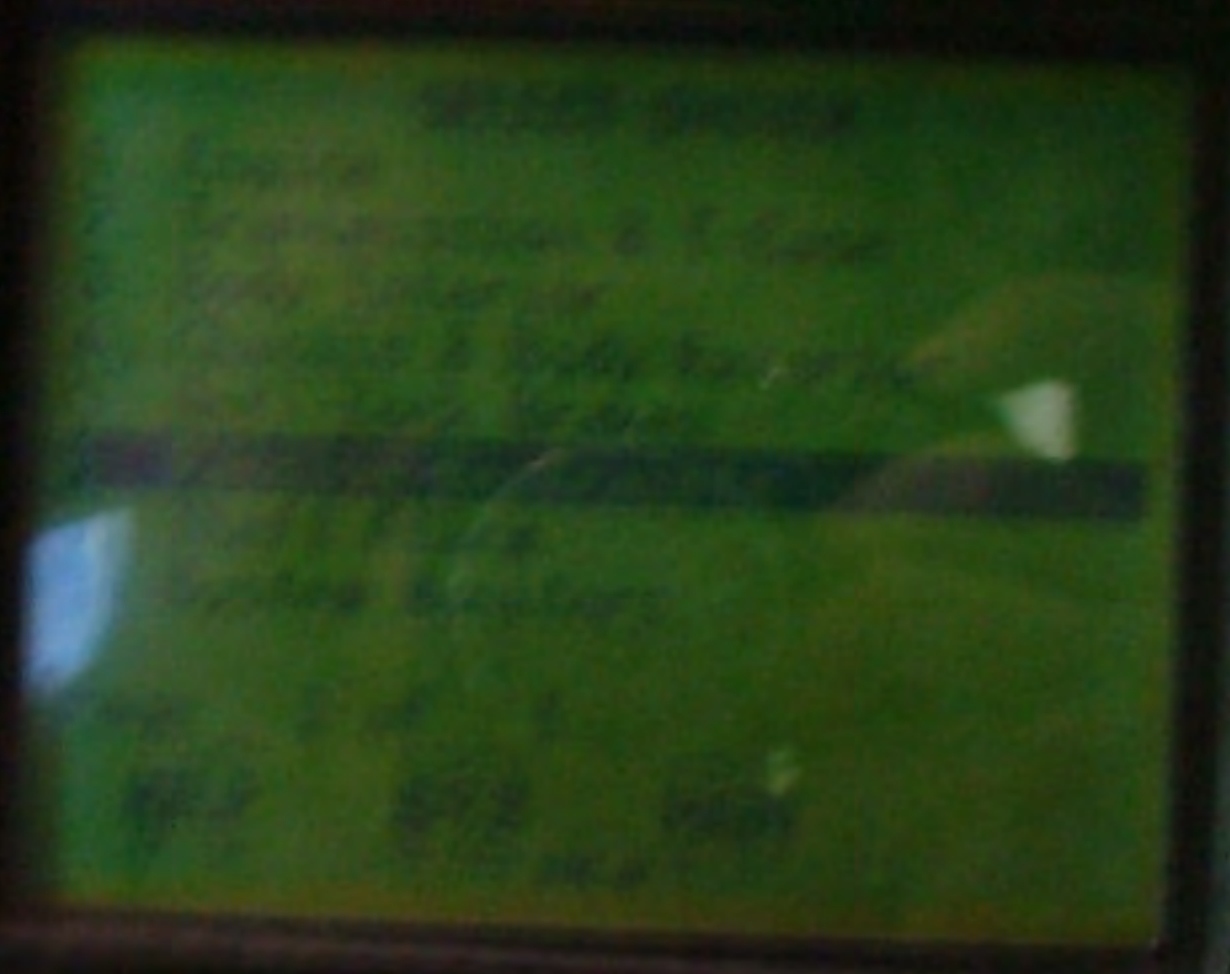

F1 F2 F3 F4



16002
141-5200
811446
3/20/06 444118
17-10-2006 6:00:00

SELECT RESTRAINT SYSTEM

- 1. Airbag
- 2. Side Airbags
- 3. Airbag On/Off Switch System
- 4. Occupant Classification S

Page 1 of 1

882 878 100

F1 F2 F3 F4



882
100

886 306 4418

7 0000 0000

1000

Interlocking Controller
Type
Please call

F1 F2 F3 F4

ENTER

501W
1500

8463W644118

6000

This Diagnostic Control
Module is not supported by
this software. Please use a
DBB III with the Superior
software to diagnose this
vehicle.

HELP STOP FWD

8091
1600
Miles

8K63W644118

ware 60-2

F1 F2 F3 F4

ENTER UP DOWN



Jeep

SRS
AIRBAG

4
5
6
RPM x1000

20
30
40
50
60
70

P
R
N
D
2
1

WARNING
DEATH OR SERIOUS
INJURY CAN OCCUR
IF AIR BAGS ARE NOT
PROPERLY MAINTAINED
OR IF THEY ARE
REPLACED WITH
NON-OEM PARTS



WARNING
DEATH OR SERIOUS
INJURY CAN OCCUR
IF AIR BAGS ARE NOT
PROPERLY MAINTAINED
OR IF THEY ARE
REPLACED WITH
NON-OEM PARTS































Jeep
LIBERTY

Jeep
LIBERTY











RV
H01-06
084031R
MEETS FMVSS 209
ASSEMBLED IN MEXICO







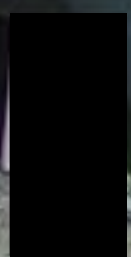



LIBERTY sport

Jeep

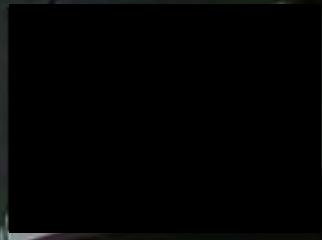



Jeep

05

Jeep



