

PE11-040

GM

2-10-2012

ATT_1_

Q_03

North American Operations

General Motors Corporation
 Disbursements (2613)
 PO Box 62530
 Phoenix, AZ 85082-2530



CHECK **No. 900882601**

50-937
213

DATE
11/02/06

*****75 DOLLARS

*****00 CENTS

AMOUNT

*****75.00

PAY TO THE ORDER OF

MANCHESTER MO

North American Operations
 General Motors Corporation
 Disbursement Account

Rachel C. [Signature]
 SIGNATURE

The Chase Manhattan Bank, N.A.
 Syracuse, New York

AUDIT

North American Operations

General Motors Corporation
 Disbursements (2613)
 PO Box 62530
 Phoenix, AZ 85082-2530

DETACH BEFORE DEPOSITING CHECK

CHECK NO. 900882601

PAYMENT DATE 11/02/06

VENDOR DUNS NO. BB 000000064

1

VENDOR NAME

REGISTER N. DESCRIPTION

DOC. REFERENCE NUMBER

% DISC.

INVOICE AMOUNT

DISC. AMOUNT

NET AMOUNT

1GDFH15T73	11/01/06 1-4302199	VM 1-7A26VA 02.1-7A26VA	00.0000	75.00	.00	75.00
------------	-----------------------	----------------------------	---------	-------	-----	-------

ACCEPTANCE OF THIS CHECK CONSTITUTES FULL RESOLUTION FOR REIMBURSEMENT OR QUESTIONS CALL 800-462-8782

W3

TOTAL

75.00

.00

75.00

February 14, 2012

[REDACTED]
Manchester, MO [REDACTED]

Service Request: 1-430219902
Customer Relationship Specialist: Rene Alexander

Dear Mr. [REDACTED]:

We sincerely regret that you experienced a concern with your 2003 GMC Savana, which resulted in an unexpected repair expense to you.

We value you as a GMC owner and your satisfaction with our products is a high priority. As we discussed over the phone, we believe you are entitled to a reimbursement. We have enclosed a check in the amount of \$75.00. We hope this goodwill adjustment will offset, to some degree, the inconvenience that this repair may have caused you.

We look forward to keeping you in our GMC family. If you have any future questions, please feel free to contact our GMC Customer Assistance Center at 1-800-462-8782 Monday through Friday between 8:00 a.m. and 11:00 p.m., Eastern Time. Please refer to your service request number above and any of our Customer Relationship Specialists will be happy to assist you.

Sincerely,

GMC Customer Assistance Center

For more information regarding the maintenance and care of your vehicle, please visit www.mygmlink.com. This free online service offers vehicle and ownership-related information and tools tailored to your specific vehicle.

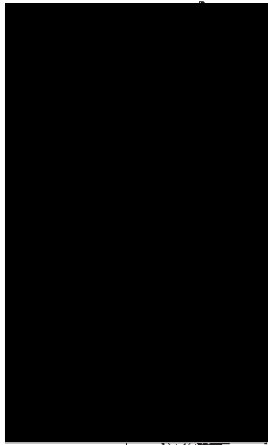

ST LOUIS, MO 631
23 SEP 2008 PM 7 L

SEP 5 2008

GMC Customer Assistance Center
P.O. Box 33172
Detroit, MI 48232-5172

48232+5172

22 September, 2006

GMC Customer Assistance Center
PO Box 33172
Detroit, MI 48232-5172

Re: Claim 1-430-219902

Dear Ms. Renee Alexander

Enclosed is the following back-up information pursuant to your request on 18 September 2006 to reimburse me for the \$100.00 charge:

- 1) Original Repair Order GCCS246599 dated 08/30/06
- 2) Original Discover Credit Receipt for \$100.00
- 3) Missouri registration renewal notice good through May 2007 (Copy)
- 4) Title # PH560294 for VIN 1GDFH15T731 [REDACTED] (Copy)

Thank you. Please call if you have any questions.

Sincerely,

A large black rectangular redaction box covering the signature area.

Manchester, MO [REDACTED]



Bommarito

Buick-GMC-Infiniti-Isuzu
Mazda-Suzuki

MAZDA



15736 MANCHESTER
8 Min. West Inter. 270
ELLISVILLE, MO 63011
PHONE 636-391-7200

ATTN: 1-430-219902

CUSTOMER NO 59599	ADVISOR CHRISTIAN PETERSEN	419	TAG NO. 3157	INVOICE DATED 08/30/06	INVOICE NO. GCCS246599
[REDACTED] MANCHESTER, MO	LABOR RATE	LICENSE NO.	MILEAGE 69,222	COLOR BLUE/	STOCK NO.
	YEAR / MAKE / MODEL 03/GMC/	DELIVERY DATE		DELIVERY MILES	
	VEHICLE I.D. NO. 1 G D F H 1 5 T 7 3 1	SELLING DEALER NO.		PRODUCTION DATE	
	F.T.E. NO.	P.O. NO.	R.O. DATE 08/30/06		
BUSINESS PHONE	COMMENTS				MO: 69222

LABOR & PARTS
J# 1 10GCZ DRIVEABILITY/FUEL TECH(S):536
OWNER STATES FUEL FILLER PIPE RUSTED THRU (ADVISE)
CUSTOMER HAS BEEN OFFERED GM ASSISTANCE \$100.00 DEDUCT
08-22-2006 1:16PM db VIA rb
HOLE RUSTED THRU AT LOWER SECTION
J1065 REPLACE FUEL FILLER NECK
POLICY ADJUSTMENT \$100.00 DEDUCTABLE

DISCLAIMER OF WARRANTIES
THE SELLER, HEREBY EXPRESSLY DISCLAIMS ALL WARRANTIES, EITHER EXPRESS OR IMPLIED, INCLUDING ANY IMPLIED WARRANTY OF MERCHANTABILITY OR FITNESS FOR A PARTICULAR PURPOSE, AND NEITHER ASSUMES NOR AUTHORIZES ANY OTHER PERSON TO ASSUME FOR IT ANY LIABILITY IN CONNECTION WITH THE SALE OF THE VEHICLE.

PARTS	QTY	FP-NUMBER	DESCRIPTION	LIST PRICE	UNIT PRICE	WARRANTY
JOB # 1	1	25755765	PIPE 3.003			
				JOB # 1 TOTAL PARTS		0.00
				JOB # 1 TOTAL LABOR & PARTS		0.00

SHOP SALES
CLAIMS FOR WORK PERFORMED MUST BE MADE WITHIN 90 DAYS OR 4000 MILES FROM DATE OF WORK
PARTS SALES
NO RETURNS ON ELECTRICAL COMPONENTS
NO RETURNS AFTER 30 DAYS
NO RETURNS ON SPECIAL ORDERS
20% HANDLING CHARGE ON ALL RETURNS
NO CLAIMS WITHOUT THIS INVOICE

MISC	CODE	DESCRIPTION	CONTROL NO	PRICE
JOB # 1	DEDUCTG	GMC-WARRANTY DEDUCTIBLE	246599	100.00
			TOTAL - MISC	100.00

COMMENTS
WAIT

TOTALS

MAZDA, ISUZU, AND GM PARTS AND LABOR ARE COVERED 12 MONTHS OR 12,000 MILES WHICHEVER OCCURS FIRST.

WE APPRECIATE YOUR BUSINESS AT FRANK BOMMARITO AND STRIVE FOR COMPLETE CUSTOMER SATISFACTION. IF YOU HAVE ANY QUESTIONS OR CONCERNS, PLEASE CALL YOUR SERVICE ADVISOR: BUICK/GMC/ISUZU/SUZUKI 636-391-7200 MAZDA 636-391-0073

TOTAL LABOR....	0.00
TOTAL PARTS....	0.00
TOTAL SUBLET....	0.00
TOTAL G.O.G....	0.00
TOTAL MISC CHG.	100.00
TOTAL MISC DISC	0.00
TOTAL TAX.....	0.00
TOTAL INVOICE \$	100.00

Bommarito
Buick-Isuzu-Mazda-GMC-Infiniti-Suzuki
15736 Manchester Road
Ellisville, Missouri 63011
(636) 391-7200
ELLISVILLE

[] CASH [] CREDIT CARD [] CHECK CK#
[] CHARGE

BOMMARITO COLLISION CENTER PROV
GUARANTEE ON MATERIALS AND WORK

Bommarito
Nissan, Inc.
661 Dunn Road
Hazelwood, Missouri 63042
(314) 731-2228
HAZELWOOD

CUSTOMER SIGNATURE

1-430-219902

BOMMARITO OLDS GMC
15736 MANCHESTER RD.
ELLISVILLE, MO. 63011
636-391-7200
TID: 00290255288981

MERCHANT ID: 29025529889
DATE: 08/30/06 8:59:16 AM

RECORD NUMBER: 001
ACCOUNT: *****1153
CARD TYPE: DISCOVER
TRAN TYPE: SALE
AUTH CODE: 636228

AMOUNT: 100.00
FORBARTY/REVEN

THANK YOU.
CUSTOMER COPY

Bommarito
Cadillac-Mazda
I-70 & Cave Springs
4190 North Service Road
St. Peters, Missouri 63376
(636) 928-2300
ST. PETERS

Bommarito
Pontiac-Mazda South, Inc.
6127 So. Lindbergh Blvd.
St. Louis, MO 63123
(314) 487-9800
SOUTH COUNTY

RENEWAL APPLICATION

(SEE INSTRUCTIONS AND CHECKLIST ON REVERSE SIDE)

YOU MAY RENEW BY MAIL, ONLINE (IF A PIN IS REGISTERED ON THIS APPLICATION) AT www.dor.mo.gov/mv/moreinfo.cfm, OR IN PERSON TO HELP AVOID LONG LINES AT THE LICENSE OFFICE, PLAN TO RENEW BEFORE THE LAST WEEK OF THE MONTH.

VALIDATE HERE

ATTN:

1-430-21990Z

PASSENGER

EMIS

CURRENT LICENSE NO.	EXP. MO.	EXP. YR.	NEW LICENSE PLATE NO.	NEW TAB NO.	NEW EXP. MO/YR.
[REDACTED]	MAY	05	[REDACTED]	L3A27460	MAY/07

VERIFY YOUR CURRENT PLATE - IF INCORRECT, PIN NO.

GROSS WEIGHT/SEAT	ZONE	FUEL	INDICATE ANY ZONE, GROSS WEIGHT, SEATING, OR FUEL CHANGE.	GROSS WEIGHT/SEAT	ZONE	NEW FUEL
		G				

SUBMIT 2004 PAID PERSONAL PROPERTY TAX RECEIPT, CURRENT INSURANCE CARD FOR VEHICLE AND TWO INSPECTIONS - SAFETY AND EMISSIONS.

YOU MUST ADD PROCESSING FEE 1-YR \$3.50, 2-YR \$7.00.

YEAR	MAKE	VEHICLE IDENTIFICATION NUMBER	RENEWAL FEE
03	GMC	1GDFH1S1731 [REDACTED]	<input type="checkbox"/> ONE YEAR \$ 23.25
BODY STYLE	TITLE NUMBER	CORPORATION	<input type="checkbox"/> TWO YEAR \$ 46.50
VAN	PH560294		<input type="checkbox"/> FUND DONATIONS \$ 0.00
L.O.V.	HP	PURCHASE DATE	PENALTY/FEE
P	48	01/27/03	10 PENALTY \$ 2.00
MILEAGE FROM SAFETY INSPECTION	43434	COUNTY	SUBTOTAL OF FEES \$ 66.50
		ST. LOUIS	REGISTRATION FEE
			<input type="checkbox"/> 1-YEAR \$ 7.00
			<input type="checkbox"/> 2-YEAR \$ 14.00
			STATE FEES \$ 13.50

FINANCIAL RESPONSIBILITY SIGNATURE PAGE REQUIRED

This is to certify that I have the operation and maintenance during the period of registration, financial responsibility and safety on the streets or highways. You must present your financial responsibility certificate to a county under Section 575.050 of Missouri law.

RECORD YOUR OLDSN/FEN NUMBER

YOU MAY OBTAIN A TWO-YEAR REGISTRATION.

0386-000 098011 *****AUTO** 5-DIGIT 13021

MANCHESTER MO OFFICE USE ONLY ATTACHED

STATE OF MISSOURI

CERTIFICATE OF TITLE

ORIGINAL

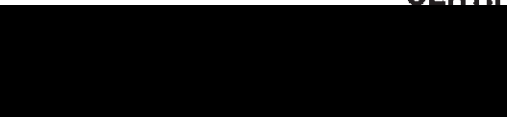

VEHICLE IDENTIFICATION NUMBER: **IGDFH15T731** [REDACTED]
 YEAR: **03** MAKE: **GMC** MODEL: [REDACTED] BODY STYLE: **VAN** FUEL: [REDACTED]
 CYL: **8** HP: **46** PREVIOUS STATE: [REDACTED] MILEAGE AT TIME OF TRANSFER: **2*** TAX PAID: [REDACTED] PURCHASE DATE: **01/27/03** DATE ISSUED: **03/03/03**

OWNER: [REDACTED]
MANCHESTER MO [REDACTED]

MAIL TO: [REDACTED]
MANCHESTER MO [REDACTED]

VEHICLE SUBJECT TO FOLLOWING LIEN(S)

RELEASE OF LIEN-The holder of lien on the vehicle described in this certificate of title does hereby state that the lien described in said certificate of title is released and discharged.

FIRST LIEN _____ LIEN DATE _____ NAME OF FIRM _____

SIGNATURE OF AUTHORIZED AGENT _____

DATE RELEASED: _____

SECOND LIEN _____ NAME OF FIRM _____

SIGNATURE OF AUTHORIZED AGENT _____

DATE RELEASED: _____

BUYER ON REVERSE SIDE MUST TITLE IN 30 DAYS TO AVOID PENALTY

MILEAGE STATEMENT _____

***ACTUAL MILEAGE.**
ANNUAL ODOMETER UPDATES MAY BE AVAILABLE FROM THE DEPARTMENT OF REVENUE.

Carl R. Fisher
 DIRECTOR OF REVENUE DOR-387 (8-97)

MO 860-0331 (8- [REDACTED])

ANY ALTERATION OR ERASURE VOIDS THIS TITLE

VOID IF EAGLE WATERMARK NOT VISIBLE WHEN HELD TO LIGHT

VOID IF EAGLE WATERMARK NOT VISIBLE WHEN HELD TO LIGHT

ATTN: 1-430-21990Z

Field Performance Report			
GM Aftersales			
FPR Case No:	65156		
Type:	GMNA Truck		
VIN:	1GBFH15T331 [REDACTED]		
Make:	Chevrolet		
Model:	Express		
Model Year:	2003		
Part Name:	Filler tube		
Location:	Body side, fuel tank		
Complaint:	Fuel Filler Tube Leaking		
Origination Point:	<input type="radio"/> Dealer <input checked="" type="radio"/> GM Internal		
Dealer Code			
GM Rep ID No			
- Affected Vehicles -			
Mileage (Miles)	Build Date		
123595			
No of Vehicles: 1			
Engine:	Transmission:		
Axle:	Transfer Case:		
- Functional Group -			
Level 1:	Level 2:	Level 3:	Level 4:
15 Induction/Exh/Fuel/Contr ols/Driveline	05 Fuel Storage & Handling	03 Fuel Plumbing & Hardware	02 Filler Neck
Trouble Category:		Trouble:	
Z - Not assignable		Not Assignable (Add new Code)	
Symptoms / Complaints:			
Fuel filler tube leaking			
Probable Cause:			
Fuel pipe corrosion			
Correction:			
Replace fuel filler tube assembly			
Sample Parts Available:		Part No:	
<input checked="" type="radio"/> Yes <input type="radio"/> No		25755765	
Remark/ Location of Parts:			
John Hamilton Engineering / VEC			

Attachments:

Name	Type
------	------

Document Information

Document Author:	Created by: KZPBYP	Date of creation: 11/09/2011 11:21:47 AM	Server of Creation: USABHEM0DB10/A/GMS ERVER/GMC
Last Modified by:	Last modified by: KZPBYP	Date of modification:	Server of Modification:
Last Accessed on:		Date last accessed : 01/25/2012 09:23:55 AM	

Vehicle Category:	GM, Used	Plan Customer:	Individual
Division:	Chevrolet	Customer Type:	Owner
VIN:	1GKFH15T731 [REDACTED]	[REDACTED]	[REDACTED]
		Arnold, Missouri, United States	[REDACTED]
		Evening Phone:	
		Primary Language:	English
		Secondary Language:	

Sales Information

Dealer Code:	32888
Action:	Add Protection Plan
Odometer:	73488
Delivery Date:	10/24/2008

Plan Lienholder

Lienholder Type:	Other
	Chevrolet
	PO Box 33170
	Detroit, Michigan - 48232

Protection Plans

Plan Purchase Date:	10/24/2008
In Service Date:	10/24/2008
Plan Type:	Smart Care Retail
Term:	12
Mileage Limit:	12000
Deductible:	0
Rental Type:	None
Plan Price:	\$ 0.00
Tax:	\$ 0.00
Total:	\$ 0.00



Transaction Details



Click the "Print" button in order to keep a record of this transaction detail. After you review the transaction details, click "Close Window".

VIN: 1GKFH15T731 [REDACTED]	Status: Pending
Dealer Code: 32888	User ID: 1w3qhs
Transaction Date: 10/24/2008	User Role: Central Office Administrator
Transaction Type: GM Protection Plan	Timestamp Date: 2008-10-29-15.11.50.635000
Transaction Messages:	
1097 - GMPP sent to MIC	



February 14, 2012

[REDACTED]
[REDACTED]
Arnold, MO [REDACTED]

Service Request: 71-668145090
Customer Relationship Specialist: Brittany Craney

Dear Mr. [REDACTED]

Thank you for your support of GMC. As we agreed, the necessary paperwork has been completed and forwarded to General Motors Protection Plan (GMPP). The processing time will take approximately eight weeks. The Smart Care Plan for your 2003 GMC Savana, Vehicle Identification Number 1GKFH15T731 [REDACTED], is for the following:

- 12 months or 12,000 miles, whichever occurs first, beginning on October 27, 2008 and ending on October 27, 2009, and begins with 73,844 and ends with 85,488 odometer miles
- A \$0.00 deductible

You will be notified by GMPP once the plan has been processed. This letter will serve as your policy until the plan confirmation is received. Please contact your local GM Dealer if you have coverage questions. Your complete satisfaction is very important to us. We hope this transaction demonstrates our appreciation of you as a valued GMC customer.

If you have any future questions, please feel free to contact our GMC Customer Assistance Center at 1-800-462-8782 Monday through Friday between 8:00 a.m. and 11:00 p.m., Eastern Time. Please refer to your service request number above and any of our Customer Relationship Specialists will be happy to assist you.

Thank you for allowing us the opportunity to assist you.

Sincerely,

GMC Customer Assistance Center

For more information regarding the maintenance and care of your vehicle, please visit www.mygmlink.com. This free online service offers vehicle and ownership-related information and tools tailored to your specific vehicle.

February 14, 2012

[REDACTED]
Doylestown, PA [REDACTED]

Dear [REDACTED],

Thank you for your support of Chevrolet. As we agreed, the necessary paperwork has been completed and forwarded to General Motors Protection Plan (GMPP) for the Smart Care plan on your 2003 Chevrolet Express, Vehicle Identification Number 1GBFH15T931[REDACTED]. The processing time will take approximately eight weeks.

You will be notified by GMPP once the plan has been processed and you will receive complete details on your plan's coverage at that time. This letter will serve as your policy until you receive your plan confirmation. Should you require service prior to receiving your plan confirmation from GMPP, simply bring this letter to your local Chevrolet Dealership. Your complete satisfaction is very important to us at Chevrolet. We hope the issuance of this GMPP demonstrates our appreciation of you as a valued customer.

At Chevrolet, our commitment to customer satisfaction is a top priority. If you have future questions, please don't hesitate to email us using the Contact Us link at Chevrolet.com or call us at 1-800-222-1020.

Sincerely,

Chevrolet Customer Assistance Center
Service Request: 71-767072781

For more information regarding the maintenance and care of your vehicle, please visit www.gmownercenter.com. This free online service offers vehicle and ownership-related information and tools tailored to your specific vehicle.

Transaction Details

Click the "Print" button in order to keep a record of this transaction detail. After you review the transaction details, click "Close Window".

VIN: 1GBFH15T93 [REDACTED]	Status: Pending
Dealer Code: 32888	User ID: 1w64ey
Transaction Date: 10/27/2009	User Role: Central Office Administrator
Transaction Type: GM Protection Plan	Timestamp Date: 2009-10-30-10.44.44.119000
Transaction Messages: 1097 - GMPP sent to MIC	

Report Vehicle Information

Vehicle & C
This screen is th
submit a request
customer inform
report.

Transaction M

Online

Vehicle Identif

Vehicle Categ

GM, Used

Division:

Chevrolet

VIN:

Full VIN

Dealer Identifi

Division:

Chevrolet

February 14, 2012

[REDACTED]
Bel Air, MD [REDACTED]

Dear [REDACTED]

Thank you for your support of Chevrolet. As we agreed, the necessary paperwork has been completed and forwarded to General Motors Protection Plan (GMPP) for the Smart Care plan on your 2003 Chevrolet Express, Vehicle Identification Number 1GBFG15T831[REDACTED]. The processing time will take approximately eight weeks.

You will be notified by GMPP once the plan has been processed and you will receive complete details on your plan's coverage at that time. This letter will serve as your policy until you receive your plan confirmation. Should you require service prior to receiving your plan confirmation from GMPP, simply bring this letter to your local Chevrolet Dealership. Your complete satisfaction is very important to us at Chevrolet. We hope the issuance of this GMPP demonstrates our appreciation of you as a valued customer.

At Chevrolet, our commitment to customer satisfaction is a top priority. If you have future questions, please don't hesitate to email us using the Contact Us link at Chevrolet.com or call us at 1-800-222-1020.

Sincerely,

Chevrolet Customer Assistance Center
Service Request: 71-982912238

For more information regarding the maintenance and care of your vehicle, please visit www.gmownercenter.com. This free online service offers vehicle and ownership-related information and tools tailored to your specific vehicle.



Report Vehicle GMPP: Summary

Current as of: 09/20/2011 - 12:01 PM EDT

Transaction Mode: Online
 User ID: 1w5x8n
 User Role: Central Office Administrator
 Timestamp Date: 2011-09-20 12:01:30.53
 Status: Pending

Vehicle Identifier

Vehicle Category: GM, Used
 VIN: 1GBFG15T831 [REDACTED]

Customer Information

Plan Customer: Individual
 Customer Type: Owner
 Mr.. Carl Sherinsky Sr
 207 Northview Road

Sales Information

Dealer Code: 32888
 Action: Add Protection Plan
 Odometer: 39600
 Delivery Date: 09/13/2011
 Reference number:

Bel Air , Maryland , United States
 21015
 Evening Phone:
 Daytime Phone:
 Ext:
 Primary Language: English
 Secondary Language:

Plan Lienholder

Lienholder Type: Other
 Chevrolet
 P.O. Box 33170
 Detroit, Michigan 48232

Protection Plans

Plan Purchase Date: 09/13/2011
 In Service Date: 09/13/2011
 Schedule Type: GMPP Retail
 Promotion Code:

Plan Type: Smart Care Retail
 Term: 12
 Mileage Limit: 12000
 Deductible: 0



Rental Type:	None
Plan Price:	□0.00
Tax:	□0.00
Total:	□0.00

PE11-040

GM

2-10-2012

ATT_1_

Q_08_B

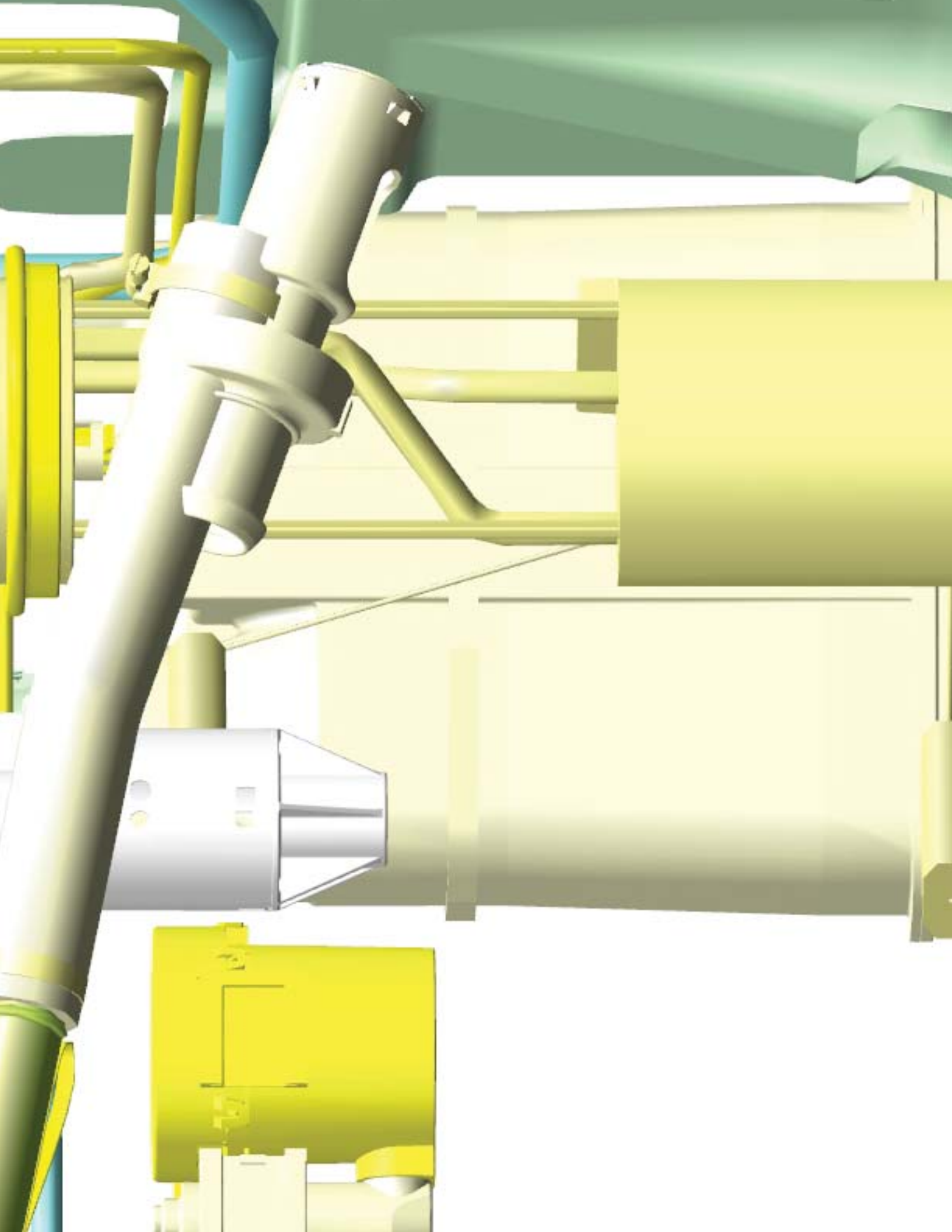





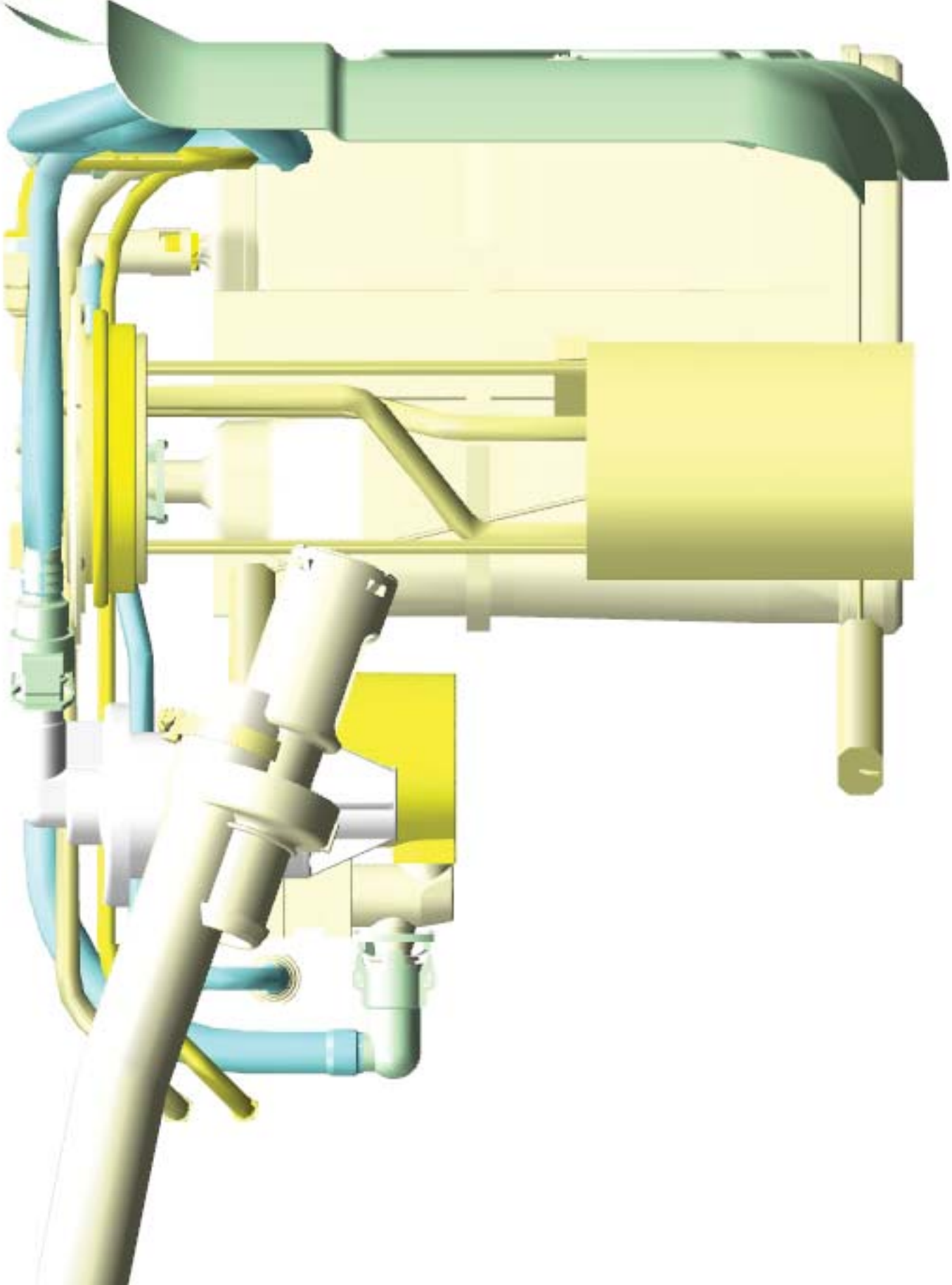



PE11-040

GM

2-10-2012

ATT_1_

Q_08_D

2003-2004 GMT 610, PN
25755765

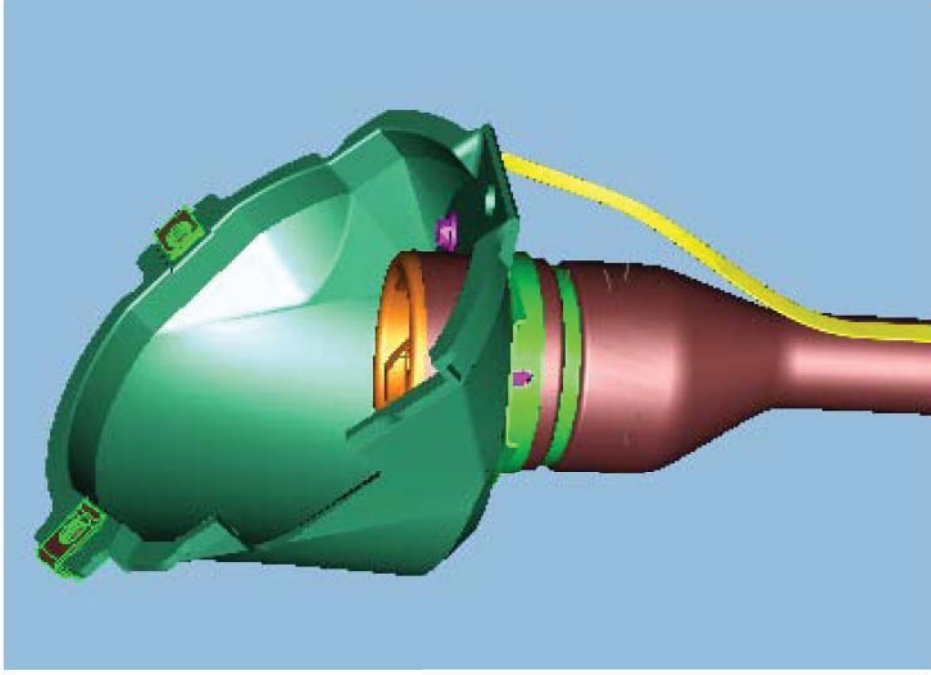

2005 GMT 610, PN 15117935
(2012 looks the same...)

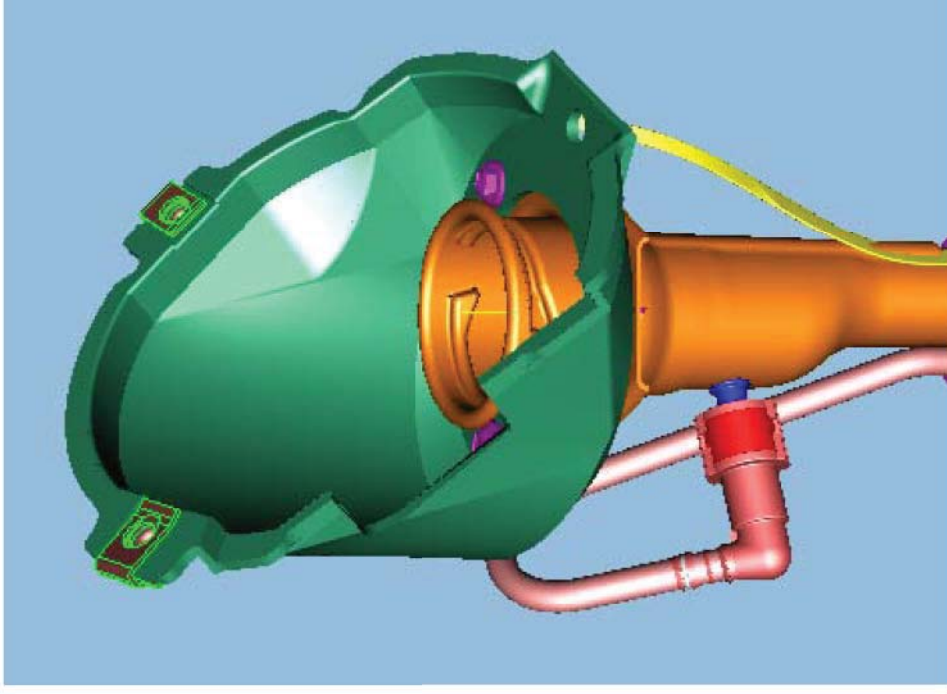

{*} Indicates GM Confidential Business Information Redacted

{*}

{*}

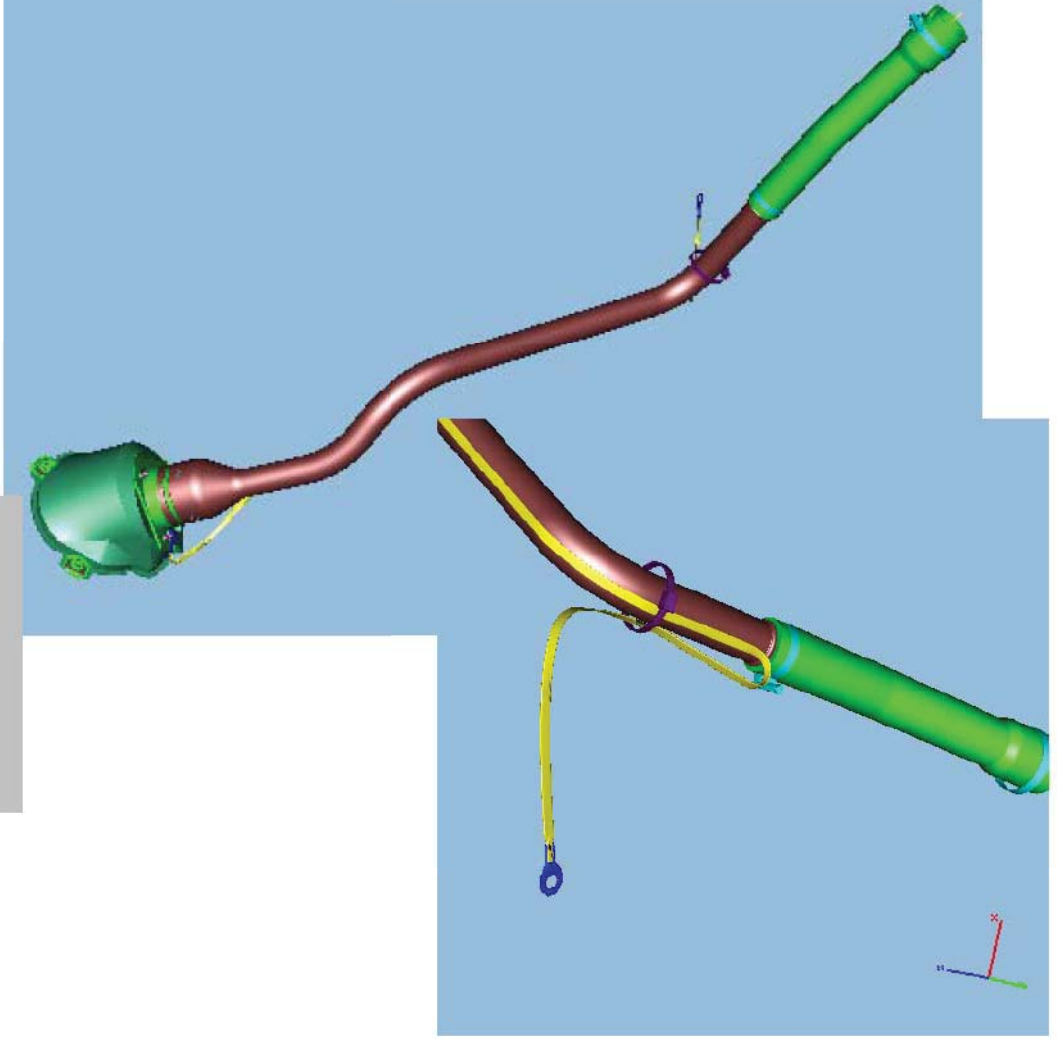
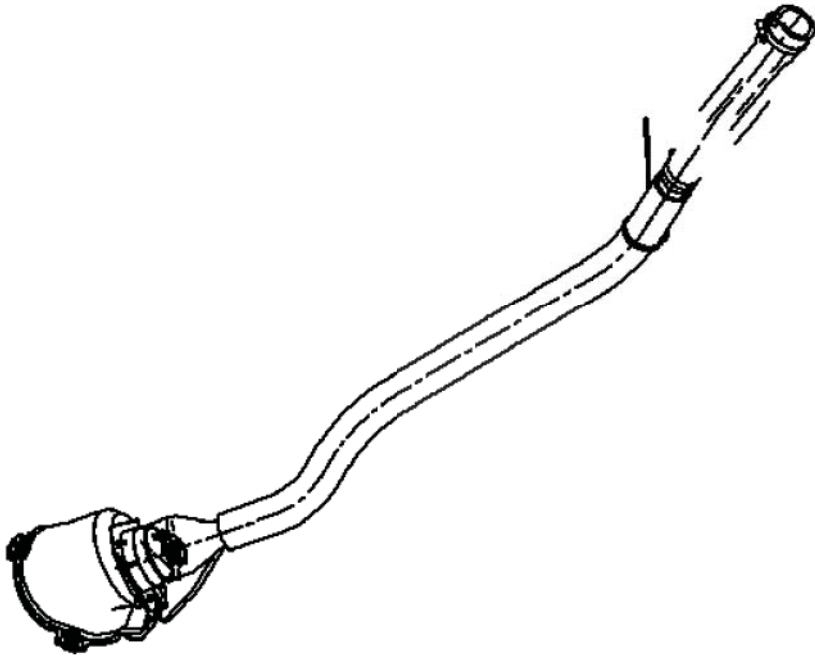

15117935 – 2004 V8 and 2005 – Current All

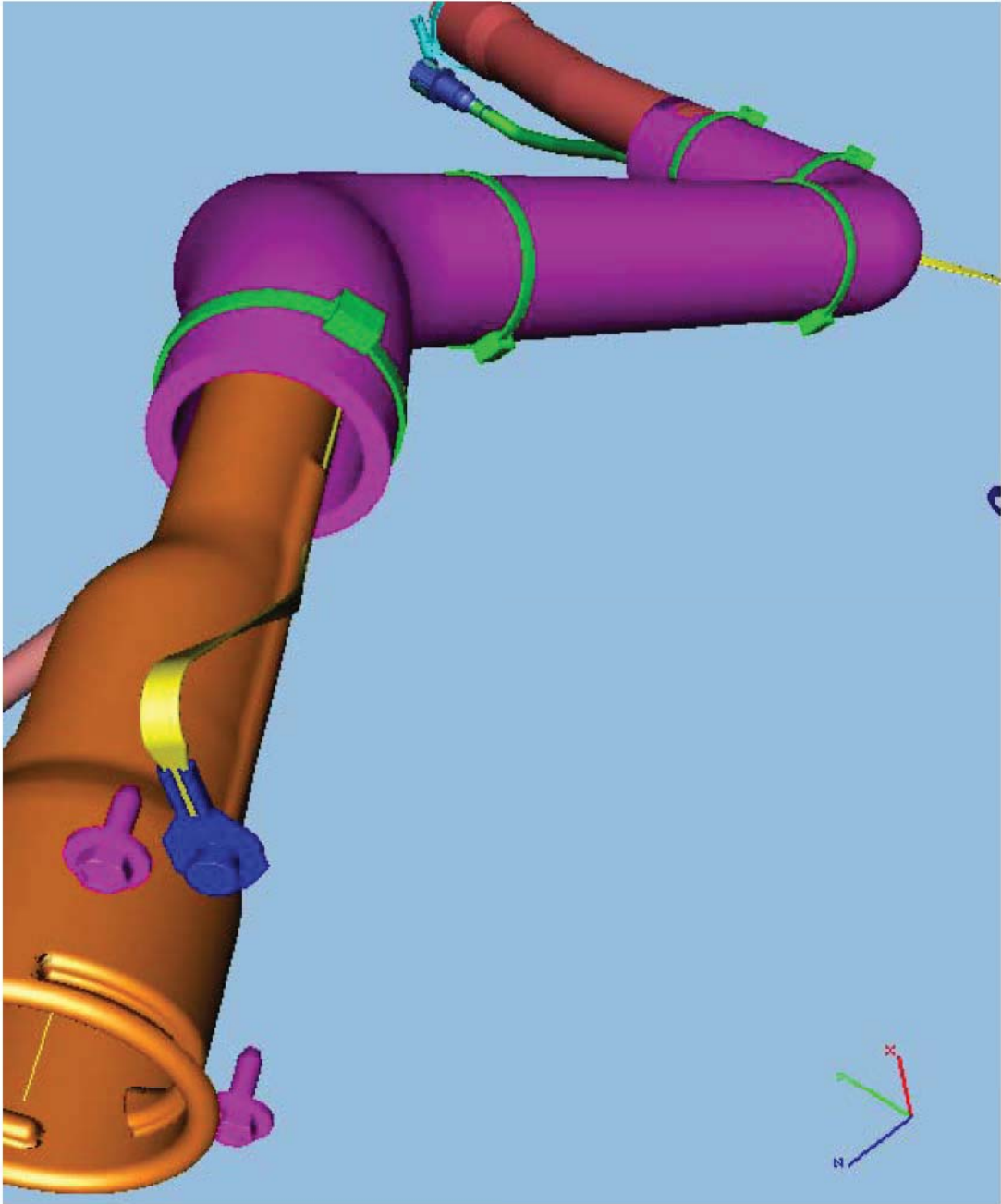

{*} Indicates GM Confidential Business Information Redacted

{**} Indicates Cost Information Redacted

2003-2004 G-Van – Fuel Filler Neck Corrosion



2003-2004MY G-van (Express/Savana) w/left cargo door, E26

22,723 Vehicles (21 countries, before attrition)

Cost Estimate: {}**

N-110359

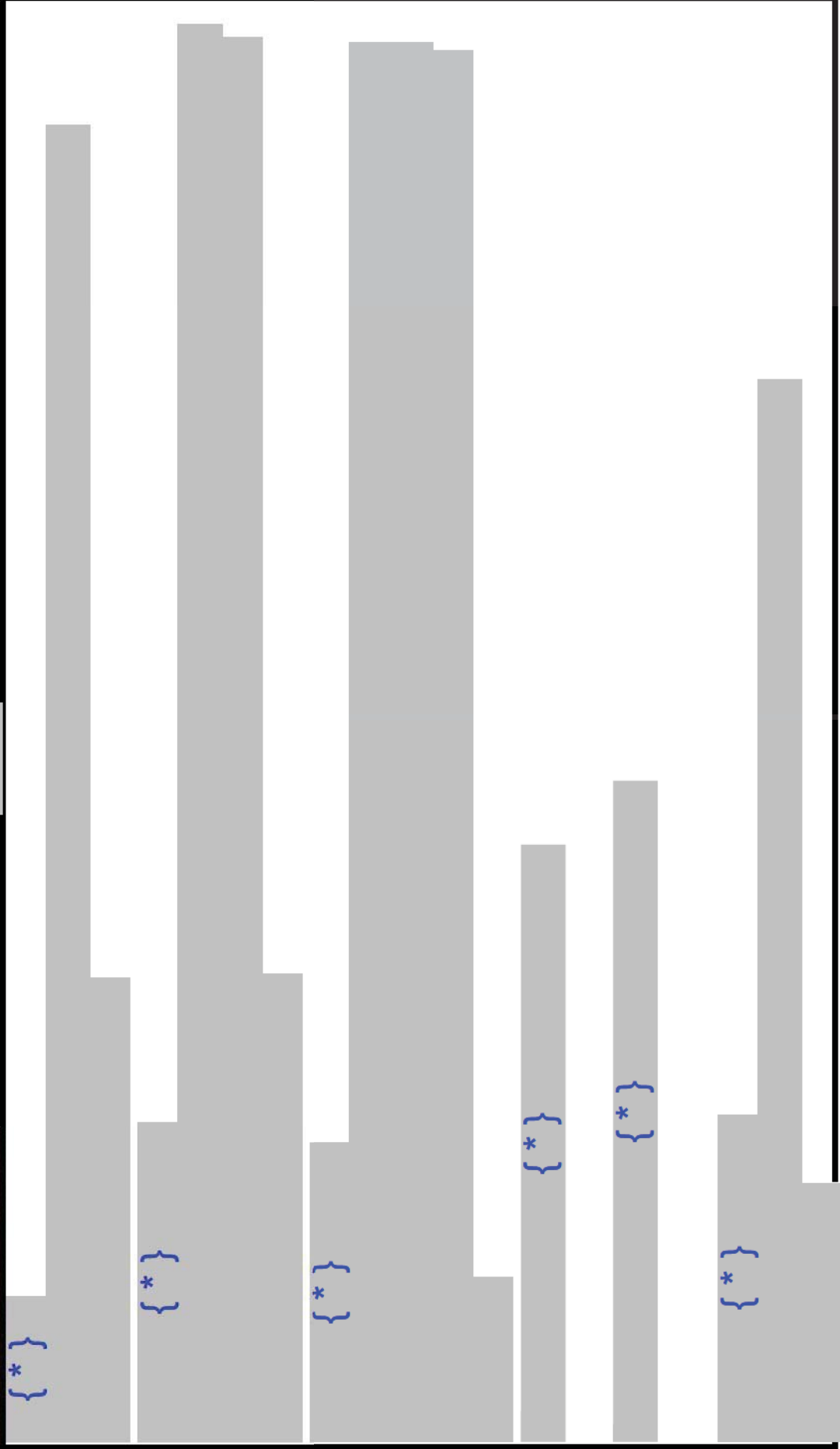



2003-2004 G-Van – Fuel Filler Neck Corrosion

GMT 610 G-Van

2003 V6/V8 and 2004 V6 (suspect)

PN 25755765

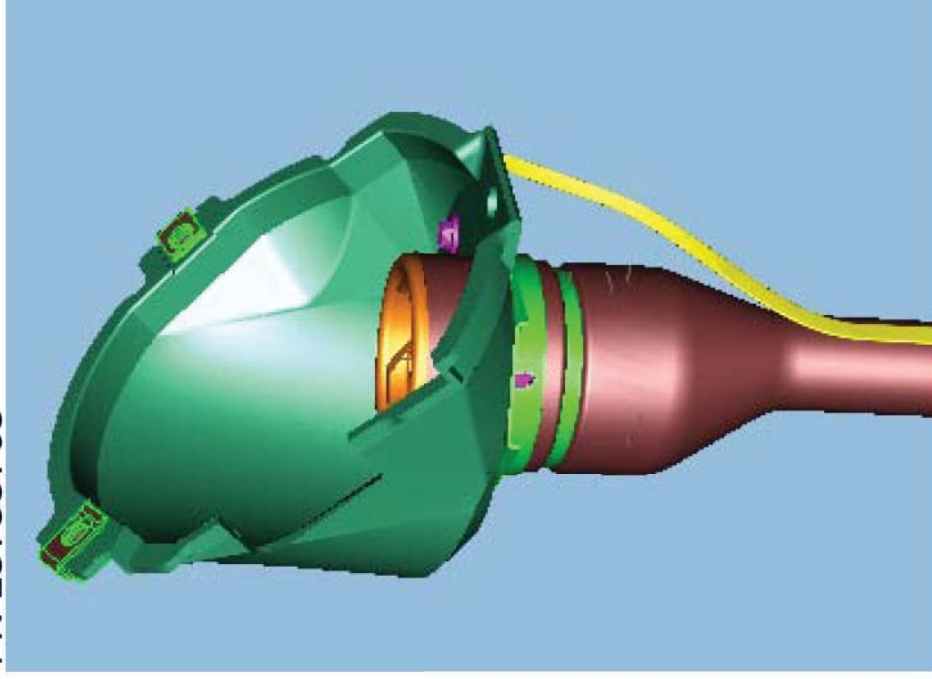

GMT 610 G-Van

2004 V8 and 2005 V6/V8 thru current

PN 15117935

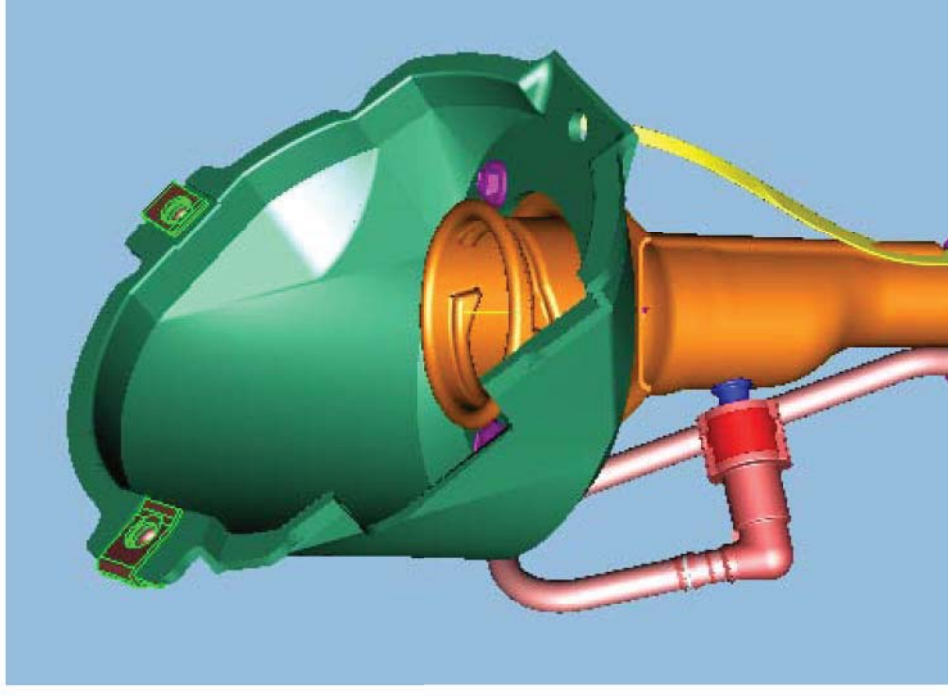



{*} Indicates GM Confidential Business Information Redacted

{*}
{*}

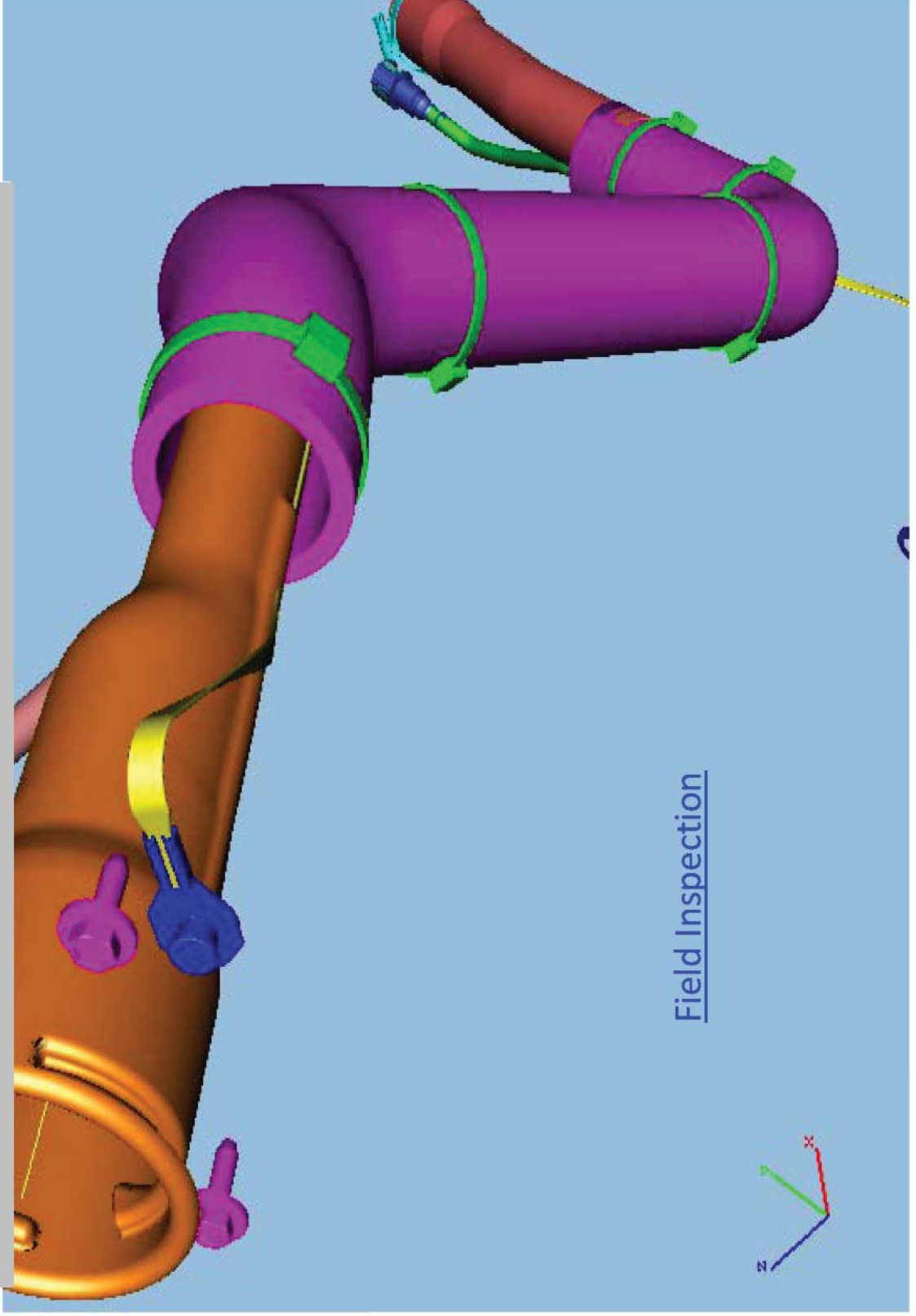

Field Inspection

6 VOQs: 2003-2004 G-Van – Fuel Filler Neck Corrosion

VOQ	Incident Date	State	VIN	MY	E26 (Y/N)	Eng	Miles	Fire(F) Crash (C) Injury(I)	VOQ Description
10413568 *	06/10/11	VA	1GCHG35U231 [REDACTED]	2003	Y	V8	51,459	None	GAS LEAKING FROM FUEL FILLER PIPE ONTO INSIDE OF WHEEL WELL AND GROUND. EXAMINATION REVEALS DESIGN OF PIPE ASSEMBLY (METAL PIPE INSIDE CORRUGATED PLASTIC TUBE), TRAPS CONDENSATION AND WATER AROUND METAL PIPE GUARANTEERING RUST AND LEAKS. MAY BE WORSE IN HIGH HUMIDITY REGIONS BUT SAME ASSEMBLY IS OPEN TO WATER SPLASHED UP FROM ROAD. THIS MAY ONLY OCCUR ON CARGO VANS WITH LEFT HAND DOOR OPTION.
10413214 *	07/10/10	IL	1GBFG15T831 [REDACTED]	2003	Y	V8	63,000	None	GAS FILLER TUBE RUSTED THROUGH AND GASOLINE LEAKED EVERY TIME I REFUELED. THIS WAS NOT A SMALL HOLE. THE METAL ON THE WHOLE TUBE BROKE DOWN CAUSING FUEL TO LEAK ...
10411911 *	06/20/11	MI	1GNFG25U73 [REDACTED]	2003	Y	V8	140,000	None	... GASOLINE WAS LEAKING FROM THE FUEL FILLER TUBE. INVESTIGATION CONCLUDED THAT THE PLASTIC CORRUGATED WRAP THAT CHEVY PLACED ON THE TUBE, TRAPS WATER, SALT, DIRT, ECT... IN IT, ALLOWING THE PIPE TO RUST,
10353717 *	09/03/10	IL	1GNFH15TX31 [REDACTED]	2003	Y	V8	92,464	None	FUEL LEAKING FROM FUEL TANK FILLER TUBE WHEN FILLING GAS TANK.
10259377 *	10/24/08	OH	1GNFG15T131 [REDACTED]	2003	Y	V8	62,000	None	SINCE OCTOBER OF 08, I ORDERED A FILLER TUBE WHICH ALLOWS THE GAS TO TRAVEL FROM THE GAS CAP TO THE GAS STORAGE TANK. EVERYTIME I FILL UP, GAS STATIONS WILL SHUT THE PUMP OFF DUE TO SEVERE LEAKING FROM THIS FILLER TUBE. THE LEAK IS SO SEVERE
10441615	12/26/11	MI	1GBFH: [REDACTED]	2003	Y	n/a	n/a	None	...GAS FILLER TUBE RUSTED THROUGH AND GASOLINE LEAKED EVERY TIME I REFUELED. CORROSION HOLES CAUSED FUEL TO LEAK AND CREATING A FIRE HAZARD. THIS VAN HAS A LEFT SIDE REAR CARGO DOOR. THIS IS A SIMILAR COMPLAINT AS: ODI ID NUMBER 10413214 (Possible duplicate)
10443143	09/01/11	MI	1GBFG [REDACTED]	2003			64,000	None	... AFTER REFUELING, 'contact' NOTICED AN OVERPOWERING FUEL ODOR. CONTACT FOUND THAT THE FUEL TANK WAS LEAKING. THE VEHICLE WAS INSPECTED BY THE DEALER AND THEY ADVISED THE CONTACT THAT THE GASOLINE FILLER TUBE NEEDED TO BE REPLACED. THE VEHICLE WAS NOT REPAIRED. THE MANUFACTURER

(*) Denotes PE11-040 VOQ



21 TREAD Records: 2003-2004 G-Van – Fuel Filler Neck Corrosion

Incident	Source	Incident Date	State	MIS to Repair	VIN	MY	E26 (Y/N)	Eng	Miles	Fire(F) Crash (C) Injury(I)	In Warranty File	Incident Description
73721445	GM Cars	11/30/10	MD	75	1GTFG15X44	2004	Y	V6	54,000	None	N	cust is having issues with the veh and he wanted to know if he still has any warranty" the gas filler tube needed to be replaced
43823517	GM Cars	08/30/06	MO	44	1GDFH15T73	2003	Y	-	69,222	None	Y	Cust noticed rust on the neck of the gas tank and if you touch it too hard you could put inger through it
44532500	GM Cars	10/17/06	IN	48	1GNGG35U83	2003	Y	-	70,000	None	N	Cust Sts: his gas filler is rusted threw and the gas feel out while pumping and feels that since the veh is only 3 yrs old it
55337969	GM Cars	03/18/08	VT	61	1GTHG35U113	2003	Y	-	56,959	None	L1225 Pump	Dir sts the reason the filler neck has rusted out and the rust was going into the
60981663	GM Cars	10/07/08	MI	63	1GNFG15T03	2003	Y	-	61,000	None	N	Cust sts: fuel filler tube corroded. drove it to a repair station. It ends up that it's spilling out uel...no one in the country has that part
61099926	GM Cars	10/16/08	NY	62	1GBFG15T93	2003	Y	-	100,000	None	N	veh had a SES light on - dir advised that the veh needs a fuel fill neck as it was corroded. Fuel fill neck is on national back order
61229421	GM Cars	10/20/08	NY	63	1GBFG15T53	2003	Y	-	49,726	None	Y	. the fuel filler tube corroded, and it is not covered under warranty, engine light come on first and they said they cant get the part anymore like for a month
66436801	GM Cars	08/25/09	IN	76	1GKFG15T53	2003	Y	-	124,587	None	N	...fuel fill tube rusting causing fuel to leak. Cust sts it's a design flaw.-denial for cost assistance delivered due to the fr reasons
66718958	GM Cars	09/24/09	MI	77	1GBFH15T73	2003	Y	-	146,000	None	N	ollow up 2nd attempt rotted out fuel filler neck 7345162506
67124387	GM Cars	10/13/09	PA	75	1GBFH15T93	2003	Y	-	77,000	None	N	SM sts: Fuel filler neck, rusted and leaking. Part was ordered 2 or 3 days ago. Part will not be available until the end of November.
67130434	GM Cars	10/12/09	MN	73	1GDFG15T33	2003	Y	-	90,000	None	N	...fuel filler pipe 25755765-ordered -it rusted out when pouring veh,gas falls out of veh
73255492	GM Cars	10/25/10	IL	92	1GDFG15T63	2003	Y	-	71,952	None	N	Please deliver the nocust fuel leak is due to rust/corrosion.
74958473	GM Cars	03/25/11	UNKNOWN	0	UNKNOWN	2003	Y	-	105,000	None	N	...the tube that put on the gasoline was completely rusted -i brought it to an indep acity-costrepair - over \$300.
76494652	GM Cars	08/15/11	IL	97	1GTHG35U13	2003	Y	-	90,000	None	N	...fuel filler neck was leaking due to corrosion
76620495	GM Cars	09/01/11	MD	102	1GBFG15T83	2003	Y	-	39,600	None	N	I was filling the tank yesterday ...i could see there was dripping gasoline. The filler pipe was rusted through... repair cost \$473.73.
76765184	GM Cars	09/15/11	OH	95	1GBFG15T03	2003	Y	-	96,000	None	N	Cst Sts: 2003 Express with 90000 miles-fuel filler neck rusted away
77396953	FPRD	11/09/11		96	1GBFH15T33	2003	Y	-	123,595	None	N	Fuel pipe corrosion
77520341	GM Cars	11/18/11	TN	105	1GBFH15T53	2003	Y	-	78,000	None	N	cust sts:...gas is still pouring out. Pulled the rear tire...looks like its rusted
52146797	GM Cars	10/08/07	PA	48	1GCFH25T03	2003	Y	-	44,010	None	N	Cust states that his check engine light came on. Dirshp diagnosed it as the gas tank neck has rusted
62355218	GM Cars	11/21/08	SC	73	1GTHG35U33	2003	Y	-	798,432	None	N	...when I am putting Gasoline into my van, it is leaking behind the sheet metal. What has happened is the fuel fill
68321839	GM Cars	01/22/10	IL	75	1GBFG15T53	2003	Y	-	100,000	None	N	CUST STS:-gas pipe was rusted out. its corroded inside a plastic tubing.-

2003-2004 G-Van – Fuel Filler Neck Corrosion Corrosive State Frequency Analysis

All Suspect Reports

(NHTSA Corrosive States within dotted line)

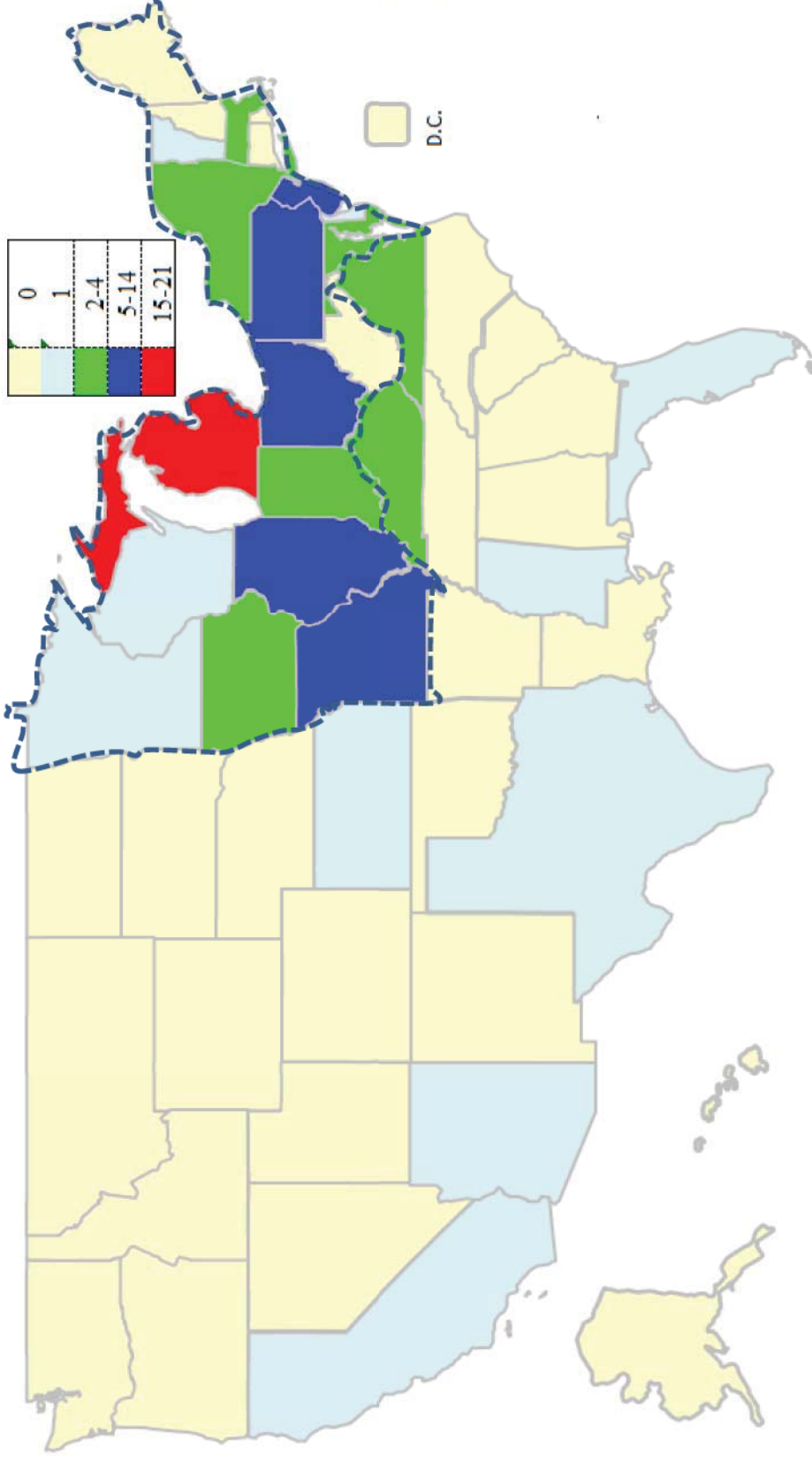

2003-2004 G-Van – Fuel Filler Neck Corrosion

Summary

Reported Cases:

6 VOQs: 5 from NHTSA IR + 1 additional discovered
None had associated warranty claims

21 TREAD Records: 2 of 21 included in the warranty claims

73 Warranty Claims: ‘Likely’ or ‘Possibly’ Related (2003 V6/V8, 2004 V6)

Service Parts Sales:

Sales Period	25755765 2003 V6/V8 2004 V6	20979210	20934913 replaced by 20979210	15117935 20934913 2004 V8, 2005-Current V6/V8	15117935 replaced by 20934913	Total 20979210 20934913 15117935
2010 Total	1490	0	7	75	82	82
2011 Total	1276	0	79	12	91	91
2010-2011 Total	2766	0	86	87	173	173

Suspect Global Population (production count) & Cost:

G-Van with E26 Left Side Cargo Door

2003 V6/V8, 2004 V6

22,723 units

{**}

2003-2004 G-Van – Fuel Filler Neck Corrosion Global Impact

Global G-Van Production Volume (w/E26)			
Engine	2003	2004	
LM7 - V8	13,410	12,100	
LQ4 - V8	2,929	2,447	
LR4 - V8	1,235	1,229	
LU3 - V6	2,313	2,836	
Total	19,887		
Total Suspect Population			22,723

LM7-ENGINE GAS, 8 CYL, 5.3L, MFI, IRON, GM
LQ4-ENGINE GAS, 8 CYL, 6.0L, MFI, IRON, GM
LR4-ENGINE GAS, 8 CYL, 4.8L, MFI, IRON, GM
LU3-ENGINE GAS, 6 CYL, 4.3L, MFI, V6, 90 DEG

Where Sold Countries (G-Van)	
AE	U. A. E.
AG	ANTIGUA AND BARBUDA
BH	BELGIUM
CA	CANADA
CR	COSTA RICA
DO	DOMINICAN REPUBLIC
GT	GUATEMALA
GU	GUAM
JM	JAMAICA
JP	JAPAN
KY	CAYMAN ISLANDS
MX	MEXICO
NL	NETHERLANDS
PA	PANAMA
PR	PUERTO RICO
QA	QATAR
SA	SAUDI ARABIA
US	UNITED STATES
VE	VENEZUELA
VG	VIRGIN ISLANDS (BRITISH)
VI	VIRGIN ISLANDS (U.S.)



{ ** } Indicates Cost Information Redacted

2003-2004 G-Van – Fuel Filler Neck Corrosion

Backup

G-Van w/E26 Side Door - Fuel Fill Pipe (Service Parts)			
Model Year	V6	V8	
2003	25755765	25755765	25755765- { ** } (365 in inventory)
2004	25755765	20934913	20979210- { ** } (12 in inventory)
2005-2011	20934913	20934913	20934913- { ** } (5 in inventory)
2012-2013	20979210	20979210	
*when the stock of (25755765 & 20934913) is depleted all of the usage will go to the 20979210			
2004-2008	15117935	&LM7/LQ4/LR4&E26.	



Model Year
2003 (V6/V8)– 2004(V6)

Model
Express & Savana

GM CONFIDENTIAL



{*} Indicates GM Confidential Business Information Redacted

2003-2004 G-Van – Fuel Filler Neck Corrosion

P0442 Evaporative DTC

The P0442 evap diagnostic to .020" as required by the regulation. . The diagnostic measures accumulated system leaks equivalent routine for detecting this size leak is a bit different than many diagnostics in a couple of ways.

1. This diagnostic monitors tank pressure when the vehicle gets turned off to determine if the fuel storage system is leaking.

[Redacted] {*}

[Redacted]

[Redacted]

[Redacted] {*}

[Redacted]

[Redacted]

[Redacted] {*}

[Redacted]

[Redacted] {*}

[Redacted]

[Redacted]

[Redacted]

[Redacted]

2003-2004 G-Van – Fuel Filler Neck Corrosion

Field inspection, 1-20-12 Arbogast Buick GMC in Troy, OH 2004-2005 MY G-Vans with E26 Left Side Door

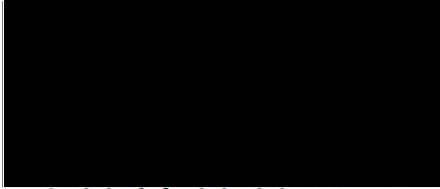

1GDPG15T641
1GBFH15T041
1GBFG15T051
1GBFG15T251
1GBFH15T641
1GDFH15T151
1GDFG15T151

2003-2004 G-Van – Fuel Filler Neck Corrosion

Arbogast Buick GMC, 2004-2005 MY G-Van field inspection



2003-2004 G-Van – Fuel Filler Neck Corrosion

Arbogast Buick GMC, 2004-2005 MY G-Van field inspection



1GBFH15T041

2004 MY V8, In Service 03/31/2005, Maine

2003-2004 G-Van – Fuel Filler Neck Corrosion

Arbogast Buick GMC, 2004-2005 MY G-Van field inspection



1GBFG15T251

2005 MY V8, In Service 06/19/2005, Florida

2003-2004 G-Van – Fuel Filler Neck Corrosion

Arbogast Buick GMC, 2004-2005 MY G-Van field inspection

1GBFG15T251

2005 MY V8, In Service 06/19/2005, Florida



2003-2004 G-Van – Fuel Filler Neck Corrosion

Arbogast Buick GMC, 2004-2005 MY G-Van field inspection



1GBFH15T641

2004 MY V8, In Service 02/28/2005, Michigan

2003-2004 G-Van – Fuel Filler Neck Corrosion

Arbogast Buick GMC, 2004-2005 MY G-Van field inspection

1GBFH15T641

2004 MY V8, In Service 02/28/2005, Michigan



6 VOQs: 2003-2004 G-Van – Fuel Filler Neck Corrosion

VOQ	Incident Date	State	VIN	MY	E26 (Y/N)	Eng	Miles	Fire(F) Crash (C) Injury(I)	VOQ Description
10413568 *	06/10/11	VA	1GCHG35U231	2003	Y	V8	51,459	None	GAS LEAKING FROM FUEL FILLER PIPE ONTO INSIDE OF WHEEL WELL AND GROUND. EXAMINATION REVEALS DESIGN OF PIPE ASSEMBLY (METAL PIPE INSIDE CORRUGATED PLASTIC TUBE), TRAPS CONDENSATION AND WATER AROUND METAL PIPE GUARANTEEING RUST AND LEAKS. MAY BE WORSE IN HIGH HUMIDITY REGIONS BUT SAME ASSEMBLY IS OPEN TO WATER SPLASHED UP FROM ROAD. THIS MAY ONLY OCCUR ON CARGO VANS WITH LEFT HAND DOOR OPTION.
10413214 *	07/10/10	IL	1GBFG15T831	2003	Y	V8	63,000	None	GAS FILLER TUBE RUSTED THROUGH AND GASOLINE LEAKED EVERY TIME I REFUELED. THIS WAS NOT A SMALL HOLE. THE METAL ON THE WHOLE TUBE BROKE DOWN CAUSING FUEL TO LEAK....
10411911 *	06/20/11	MI	1GNNG25U73	2003	Y	V8	140,000	None	...GASOLINE WAS LEAKING FROM THE FUEL FILLER TUBE. INVESTIGATION CONCLUDED THAT THE PLASTIC CORRUGATED WRAP THAT CHEVY PLACED ON THE TUBE, TRAPS WATER, SALT, DIRT, ECT... IN IT, ALLOWING THE PIPE TO RUST, WITHOUT THE DRIVER/OWNER NOTICING THE DAMAGE UNTIL IT STARTS LEAKING. AS A FIREFIGHTER, I REALIZE THE DANGERS OF GASOLINE LEAKING UNDER A VEHICLE, I FEEL THAT THIS IS A SERIOUS DESIGN FLAW FOR THE FILLER TUBE.
10353717 *	09/03/10	IL	1GNFH15TX31	2003	Y	V8	92,464	None	FUEL LEAKING FROM FUEL TANK FILLER TUBE WHEN FILLING GAS TANK.
10259377 *	10/24/08	OH	1GNFG15T131	2003	Y	V8	62,000	None	SINCE OCTOBER OF 08, I ORDERED A FILLER TUBE WHICH ALLOWS THE GAS TO TRAVEL FROM THE GAS CAP TO THE GAS STORAGE TANK. EVERYTIME I FILL UP, GAS STATIONS WILL SHUT THE PUMP OFF DUE TO SEVERE LEAKING FROM THIS FILLER TUBE. THE LEAK IS SO SEVERE THAT THE FEAR IS SOMEBODY DROPPING A CIGARETTE AT THE TIME OF FILLUP. APPROX 1 GAL OF GAS LEAKS/ FILLUP. I ORDERED THE NEW PART IN LATE OCTOBER FROM THE DEALERSHIP I PURCHASED MY 2003 CHEVY PASSENGER EXPRESS VAN. I HAVE SPOKEN TO THE CHEVY REGIONAL OFFICE AND BEEN TOLD THAT THE PART IS ONLY AVAILABLE AT 5 DEALERSHIPS IN THE COUNTRY BUT THEY HAVE BEEN RESERVED FOR CUSTOMERS AND I WOULD HAVE TO WAIT UNTIL THE PART GETS MANUFACTURED ONCE AGAIN. WHEN? THEY DON'T KNOW.
10441615	12/26/11	MI	1GBFH	2003	Y	n/a	n/a	None	...GAS FILLER TUBE RUSTED THROUGH AND GASOLINE LEAKED EVERY TIME I REFUELED. CORROSION HOLES CAUSED FUEL TO LEAK AND CREATING A FIRE HAZARD. THIS VAN HAS A LEFT SIDE REAR CARGO DOOR. THIS IS A SIMILAR COMPLAINT AS: ODI ID NUMBER 10413214 (Possible duplicate)
10443143	09/01/11	MI	1GBFG	2003			64,000	None	... AFTER REFUELING, 'contact' NOTICED AN OVERPOWERING FUEL ODOR. CONTACT FOUND THAT THE FUEL TANK WAS LEAKING. THE VEHICLE WAS INSPECTED BY THE DEALER AND THEY ADVISED THE CONTACT THAT THE GASOLINE FILLER TUBE NEEDED TO BE REPLACED. THE VEHICLE WAS NOT REPAIRED. THE MANUFACTURER WAS CONTACTED AND THEY OFFERED NO ASSISTANCE. THE FAILURE MILEAGE WAS APPROXIMATELY 64,000.

NHTSA – Corrosion States

Per NHTSA letter NSA-11jdw (ref ODI RQ97017) received 9/4/98, minimum states to be included for problems related to corrosion from long term exposure to road salt

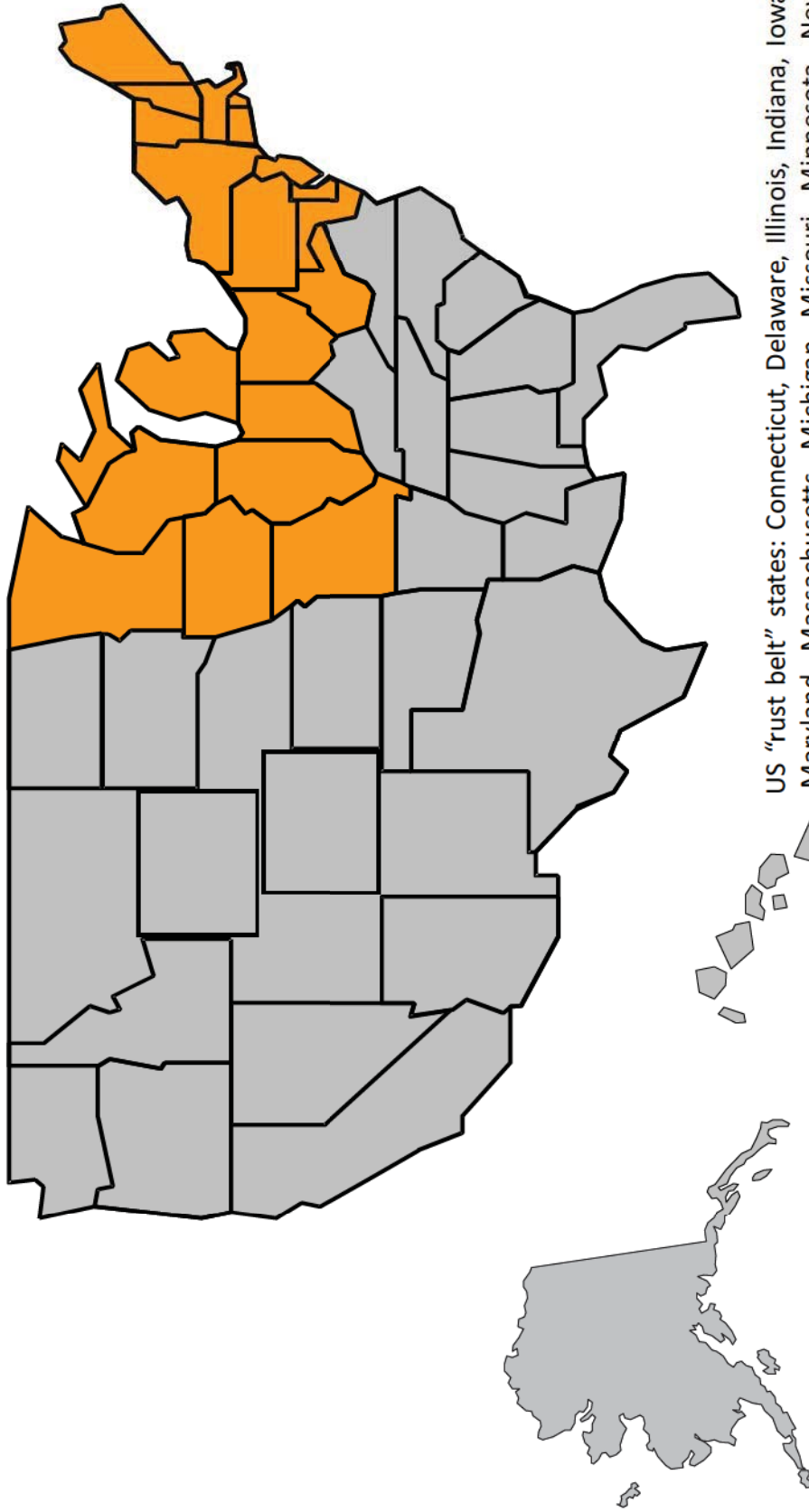

US "rust belt" states: Connecticut, Delaware, Illinois, Indiana, Iowa, Maine, Maryland, Massachusetts, Michigan, Minnesota, Missouri, New Jersey, New York, New Hampshire, Ohio, Pennsylvania, Rhode Island, Vermont, Wisconsin, West Virginia, and the District of Columbia

Regions of Corrosive Severity

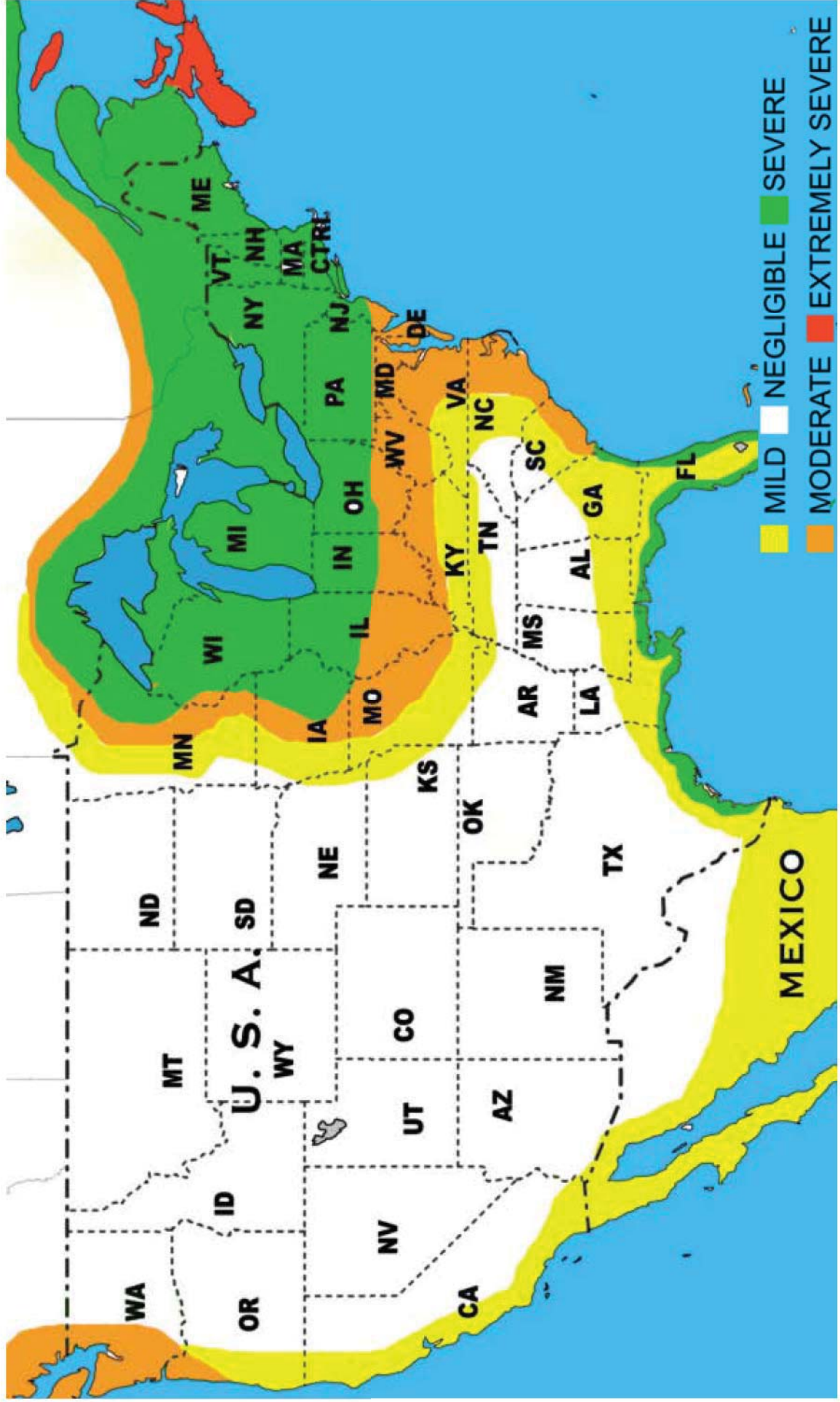

PE11-040

GM

2-10-2012

ATT_1_

Q_08_E



Re: G-van Fuel Fill
Robert VanHorn to: Joe Voyt
Cc: Gary Smits, Jeffrey Lobb

01/21/2012 12:48 PM
[Hide Details](#)

From: Robert VanHorn/C/US/GM/GMC
To: Joe Voyt/US/GM/GMC@GM
Cc: Gary Smits/US/GM/GMC@GM, Jeffrey Lobb/C/US/GM/GMC@GM

Joe,

I have attached a power point containing the pictures of the 7 vehicles I was able to examine on Friday. One of the vehicles you had listed did not have the correct option code and the other two vehicle could not be located by the dealership.



Dave Arbogast Fuel Neck G vans.pptx

R. Van Horn
HP Enterprise Services
Representing GM Customer Care & Aftersales
Field Service Engineering (FSE)
Cell:859-409-9665

▼ Joe Voyt

Hi Bob, I'll call to discuss.

01/19/2012 03:36:09 PM

1GDPFG15T641

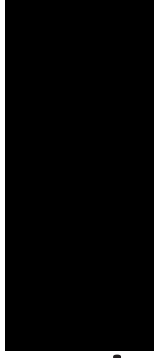



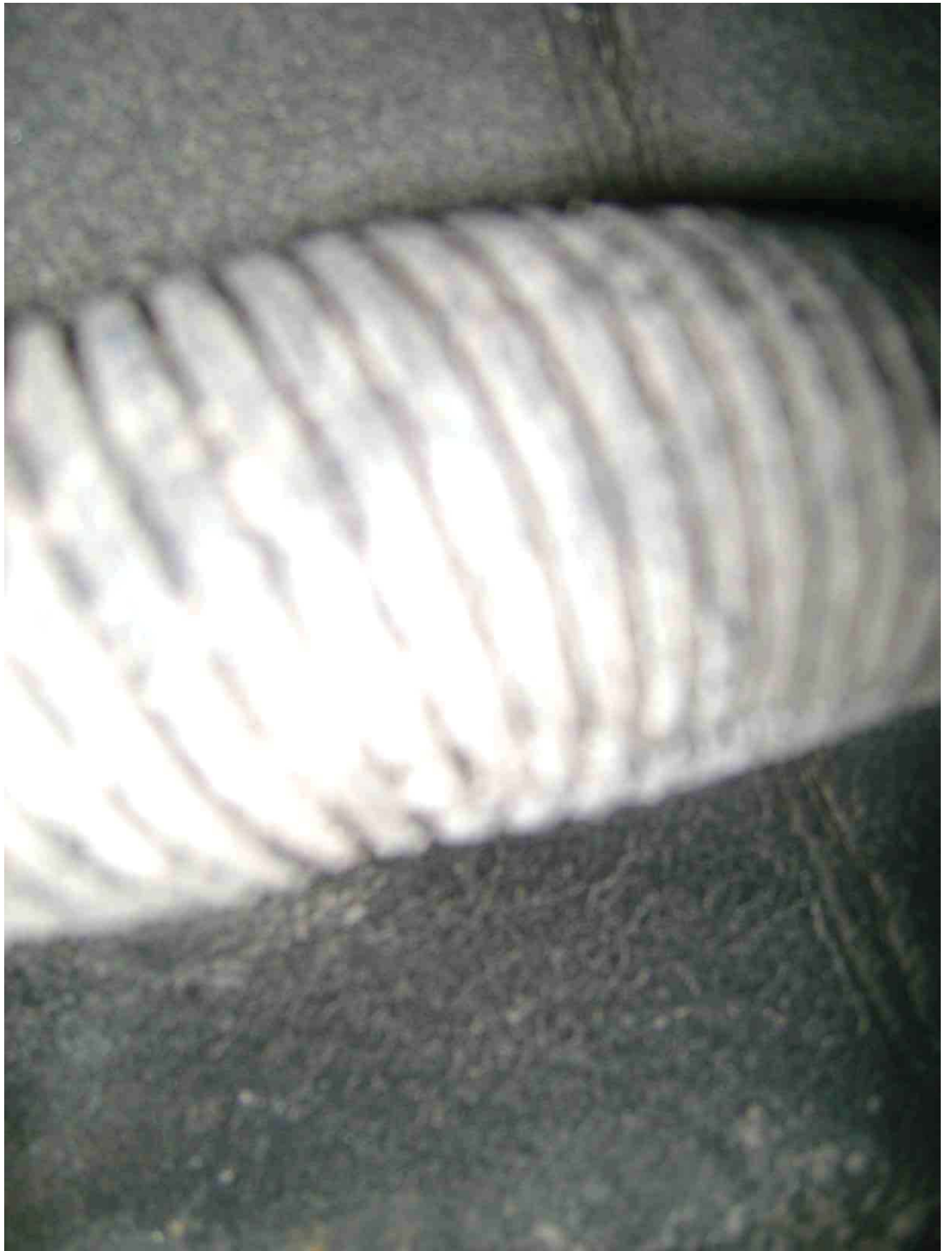



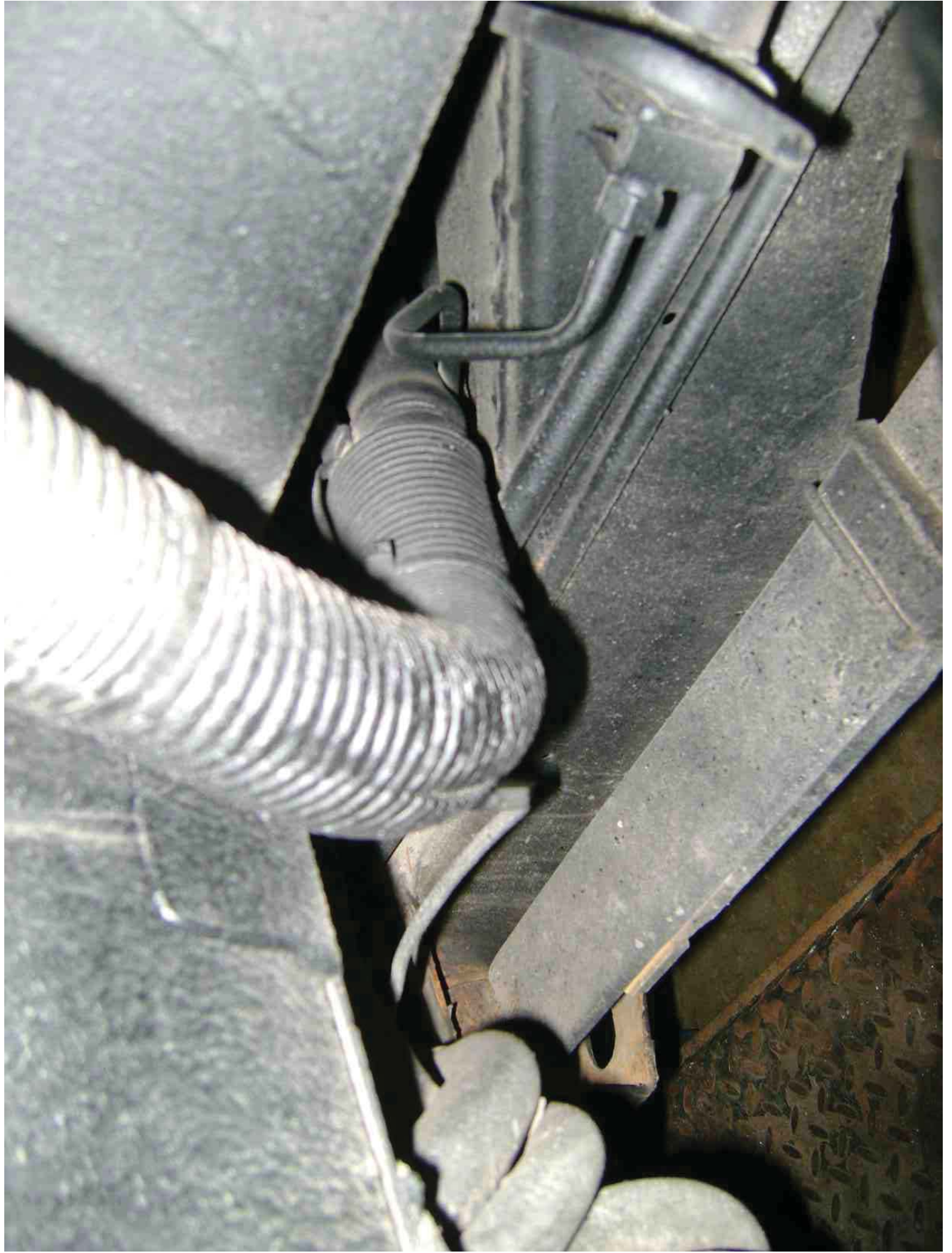

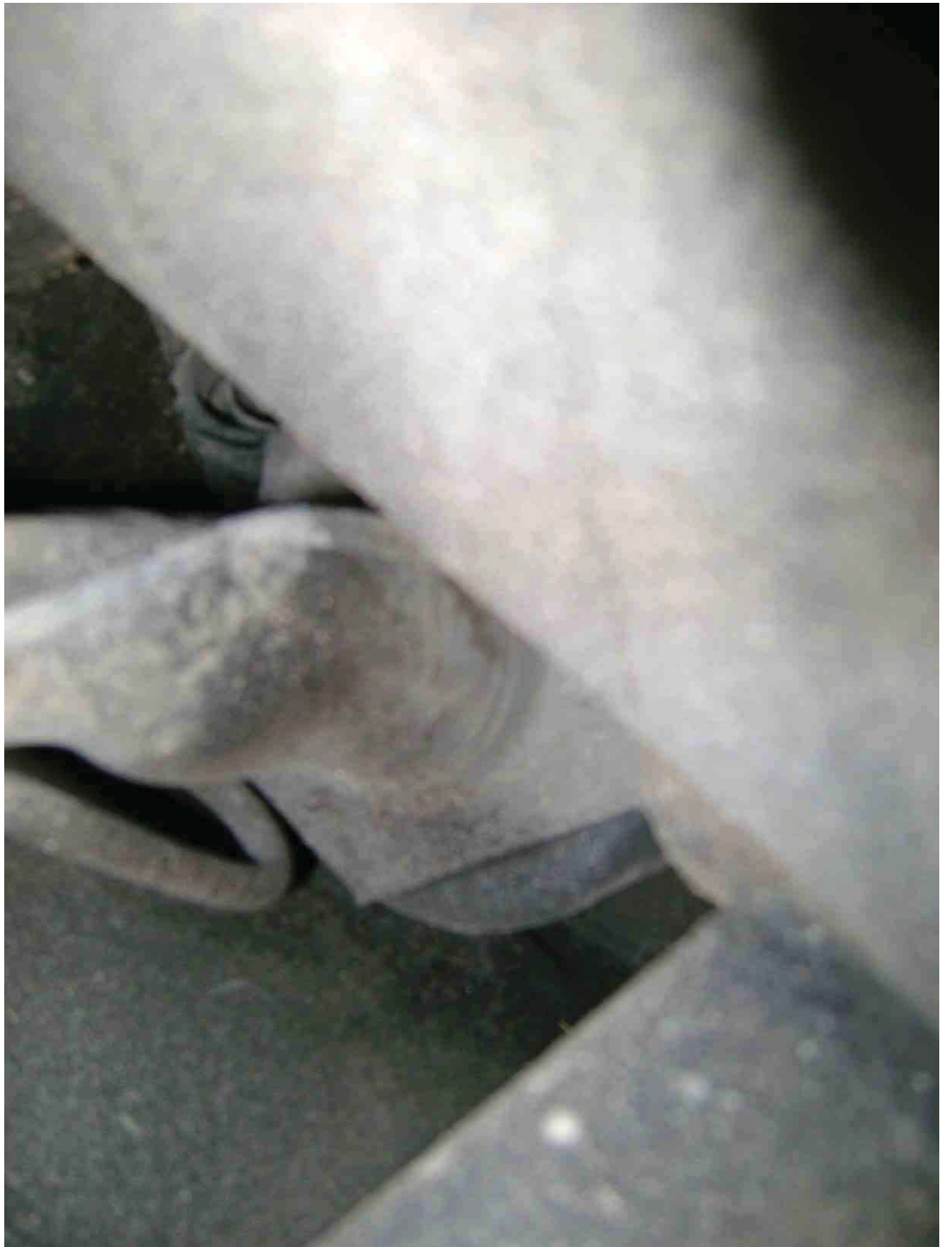





1GBFH15T041

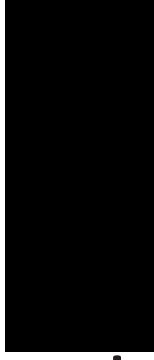

1GBFH15T041



1GBFH15T041







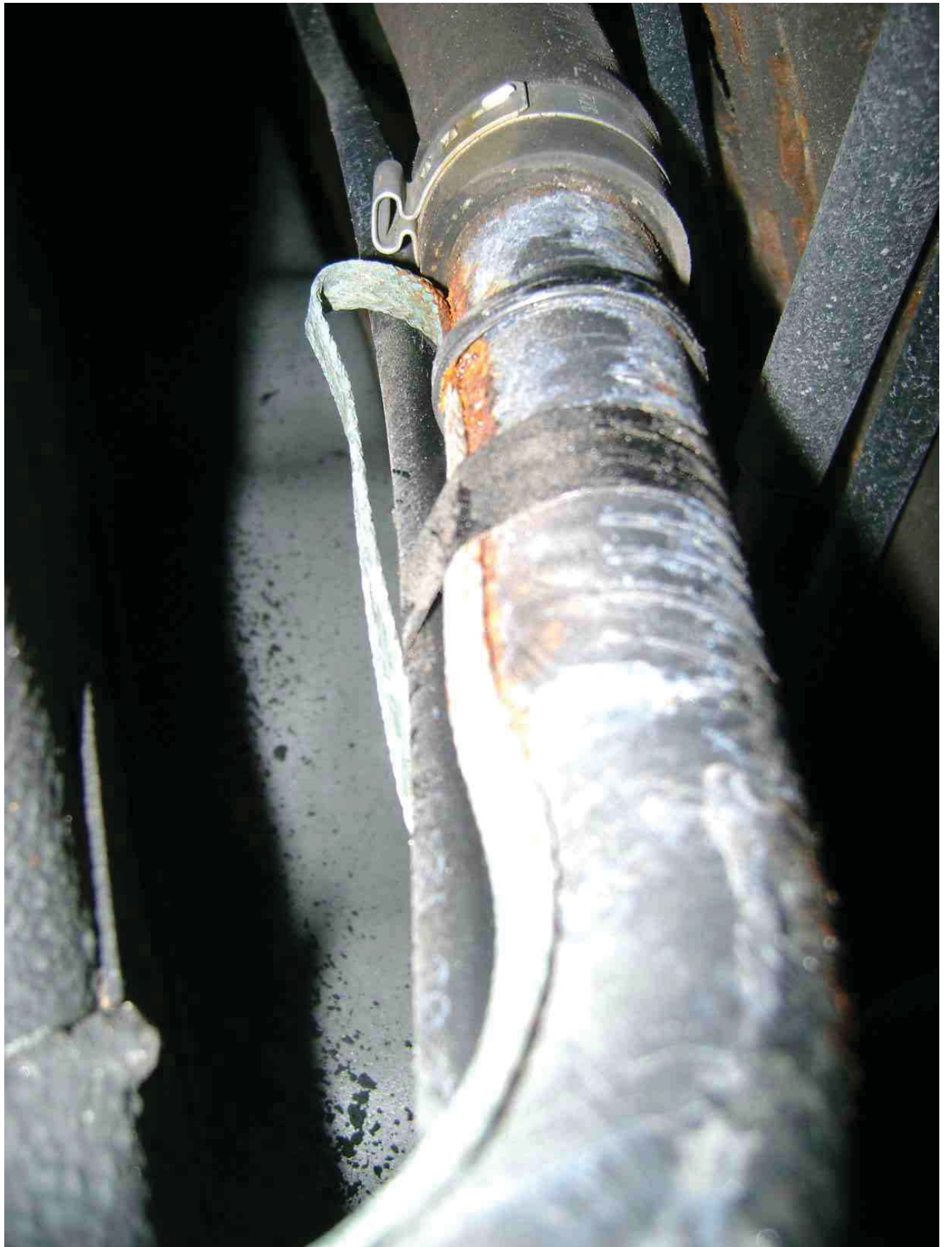

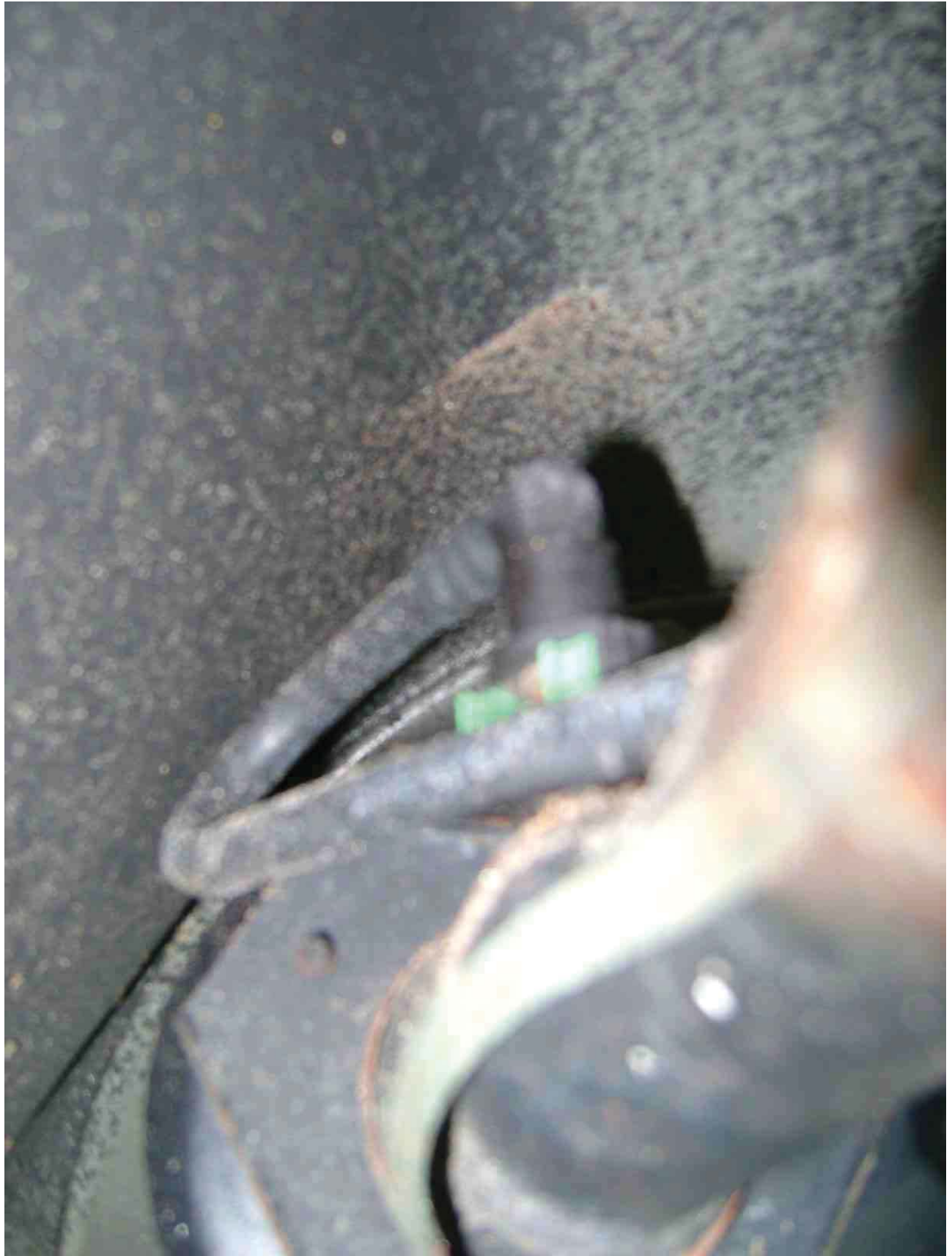



1GBFG15T051

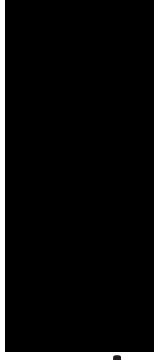

1GBFG15T051

1GBFG15T051



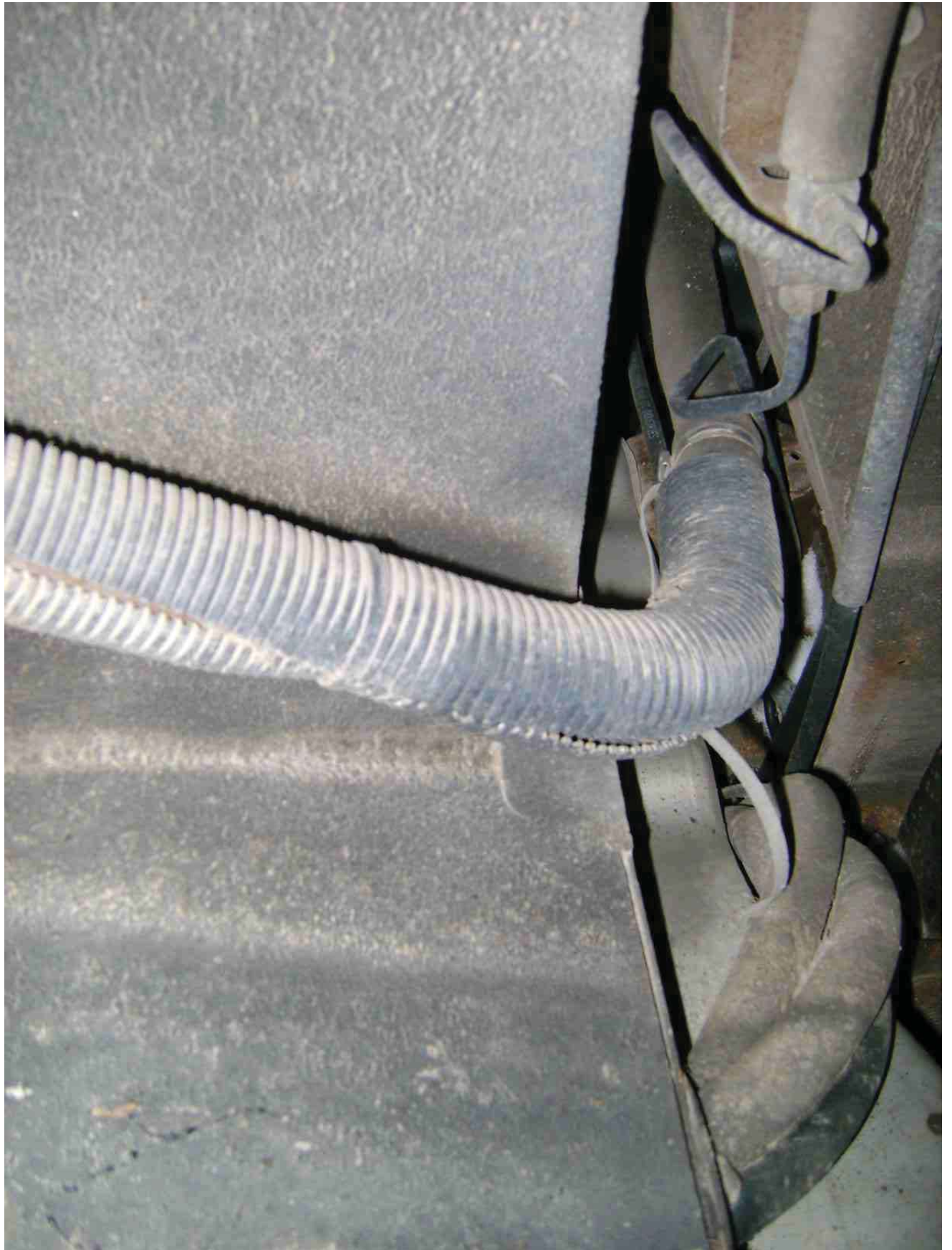

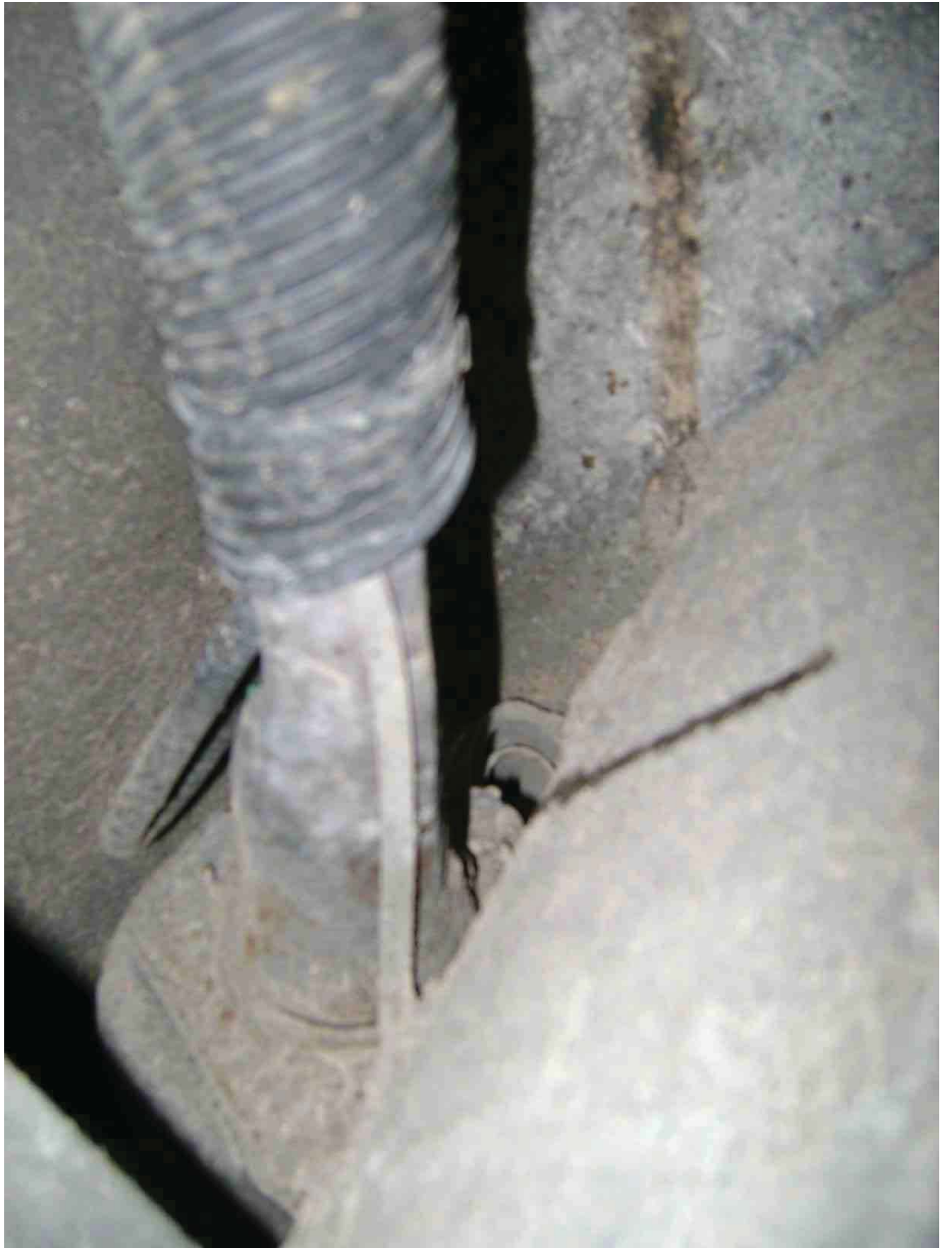

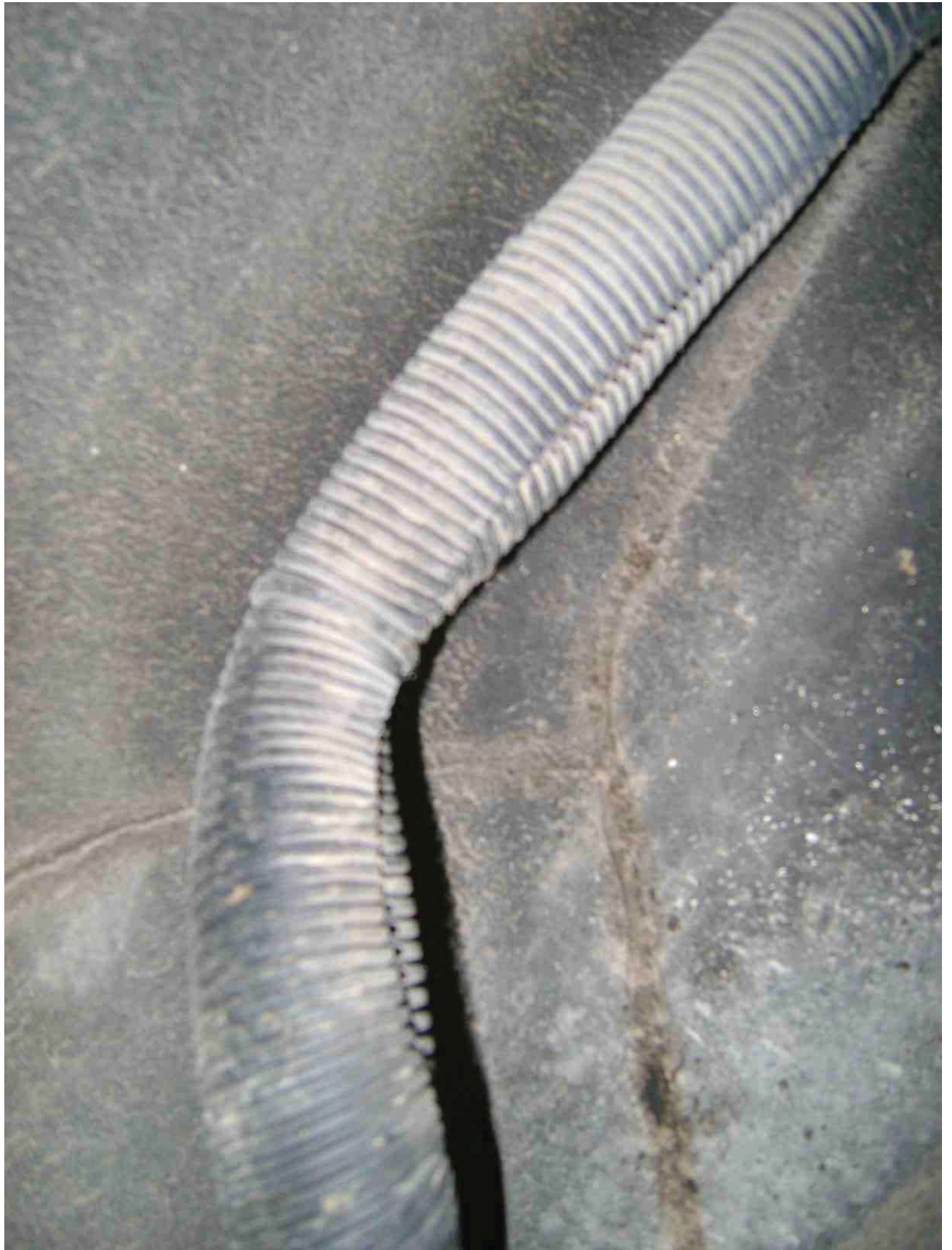





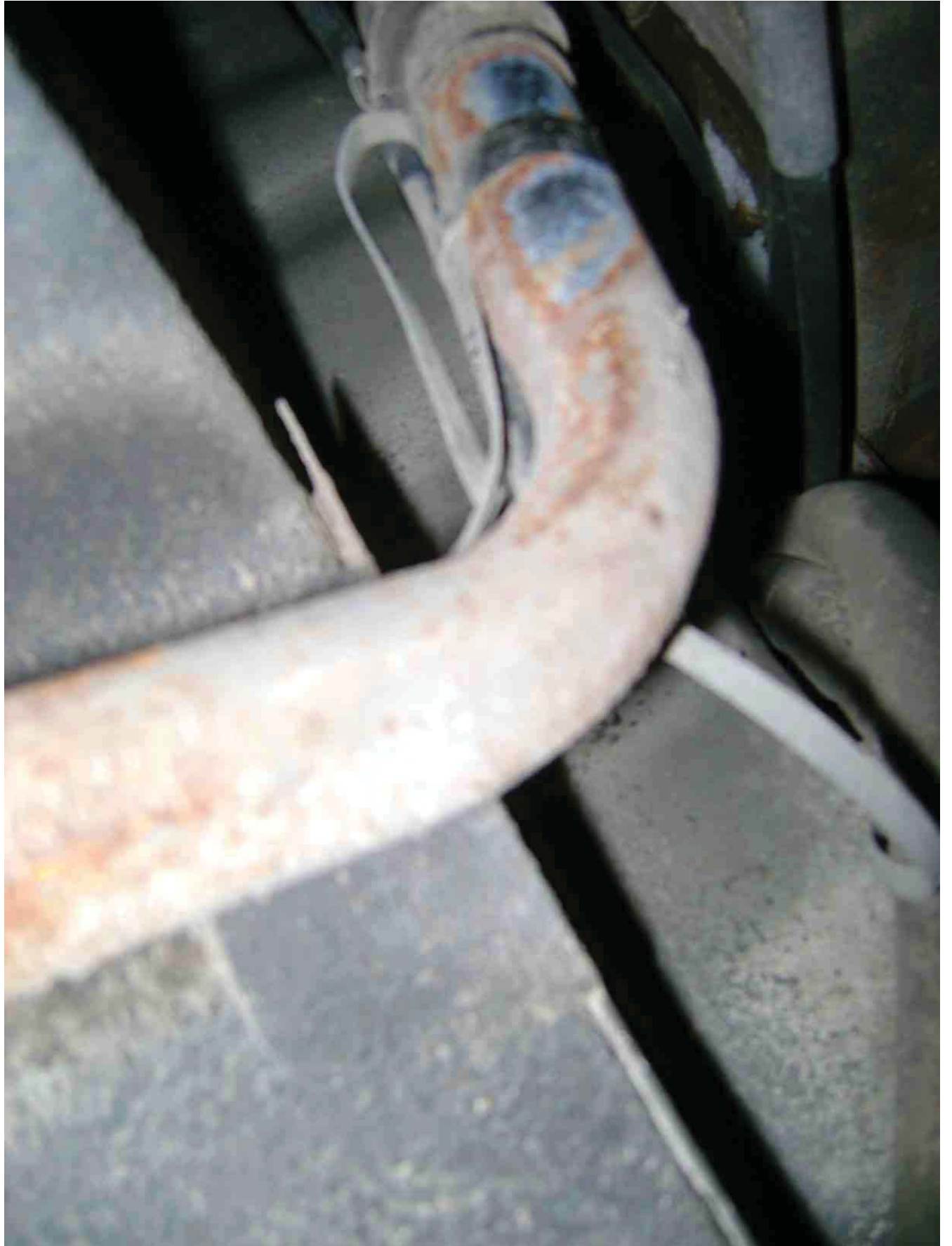

1GBFG15T251

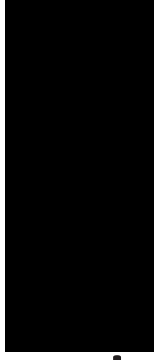

1GBFG15T251

1GBFG15T251

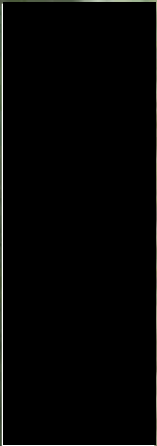
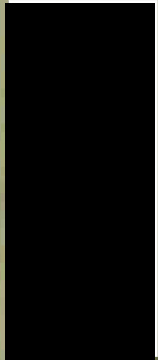







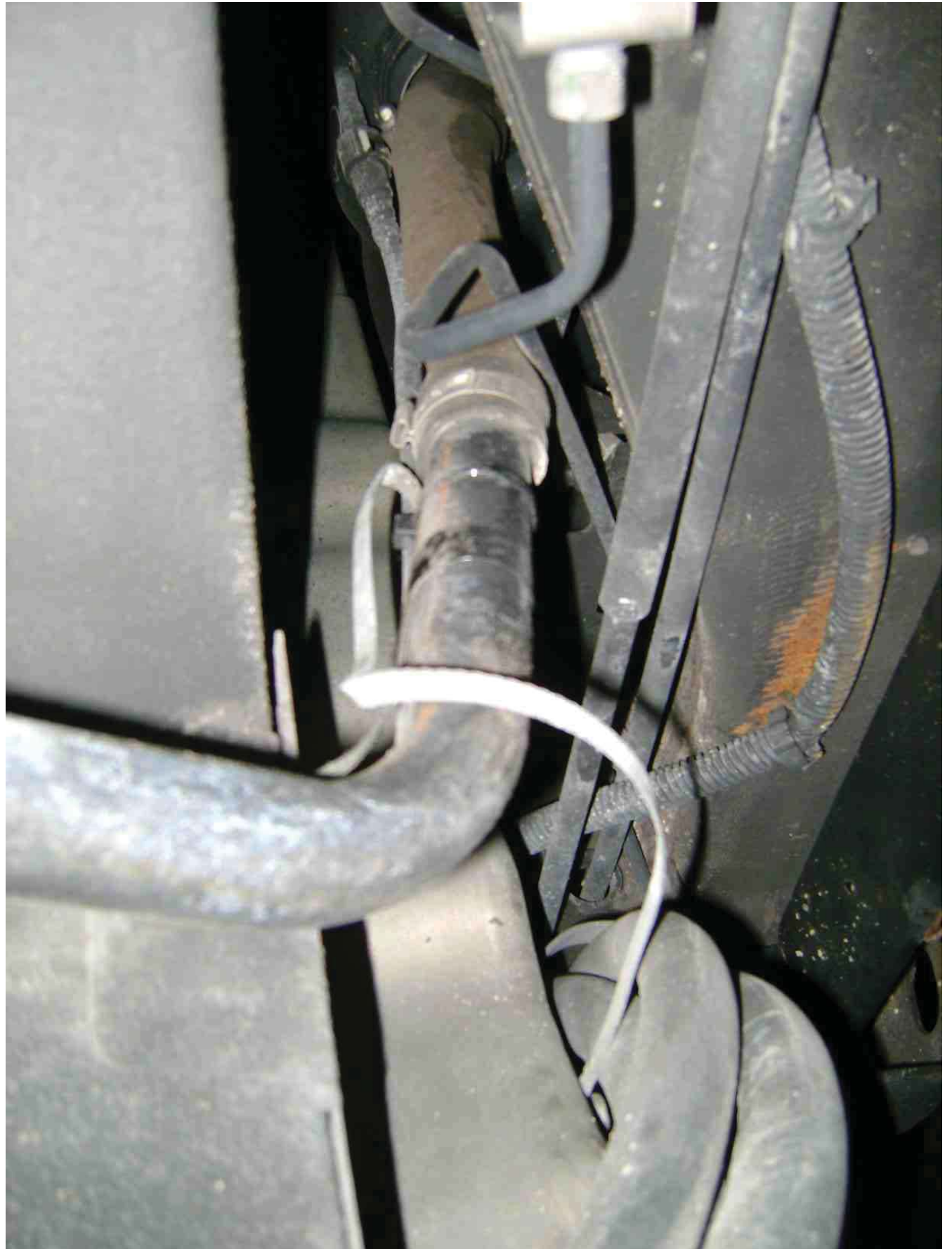





1GBFH15T641

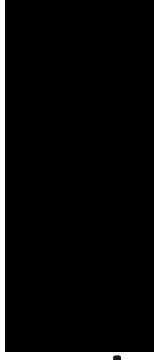

1GBFH15T641



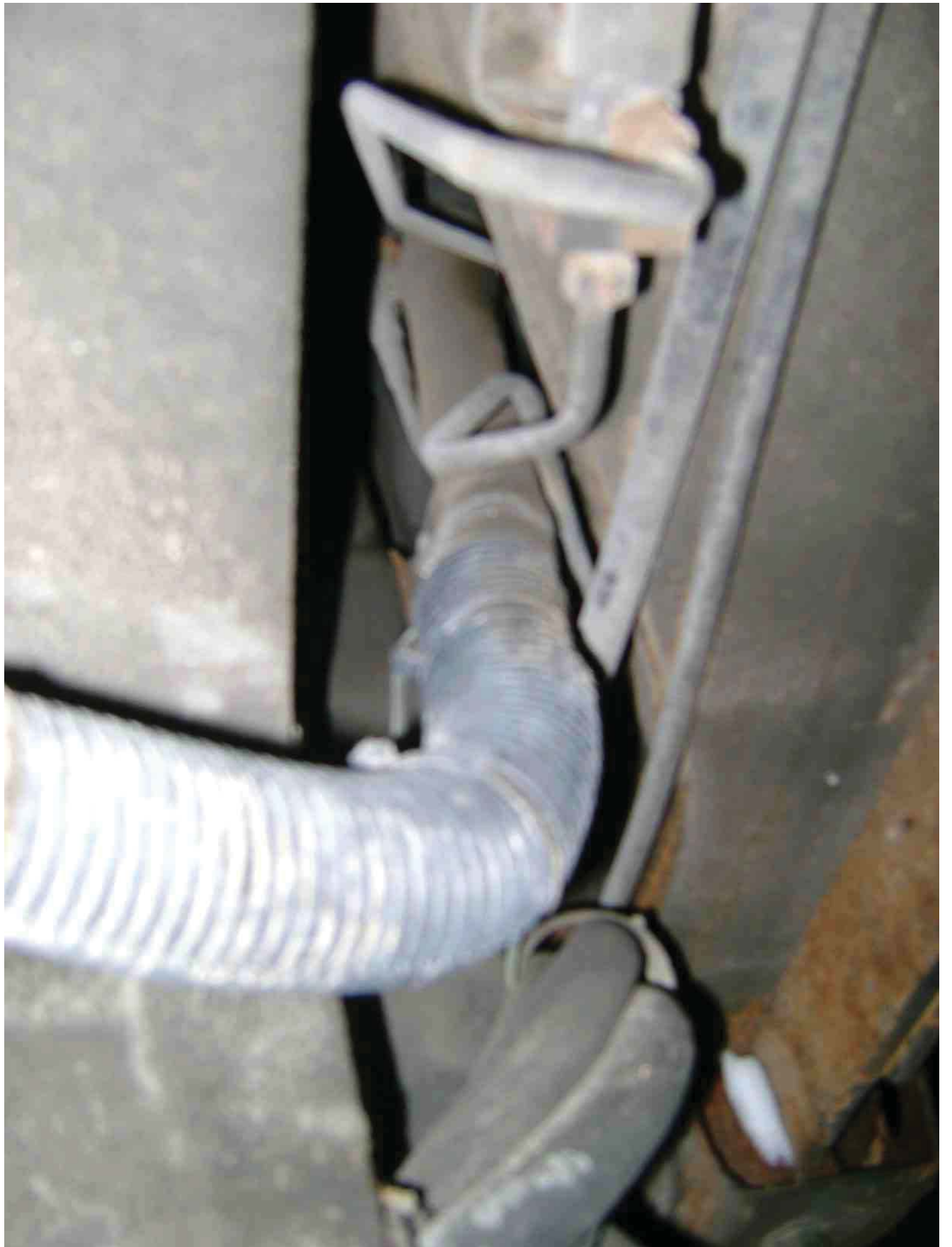











1GDFH15T15

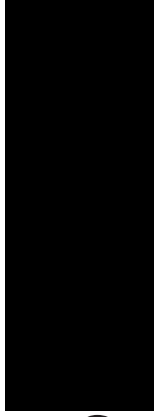

1GDFH15T151

1GDFH15T151

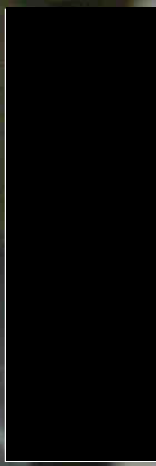













1GDFG15T151

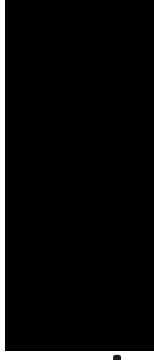













VehicleVIN:
1GBFH15T331 [REDACTED]
CH13405Transaction:
001105420139

Non GM Vehicle Indicator:

Delivery Type:
021Odometer:
123595Assigned Warranty Start Date:
12/17/2003Business Unit:
GM - USRepairing BAC:
115098-JOE LUNGHAMER
CHEVROLET, INC.**Transaction Header Information:**Job Card:
524955Job Card Line:
1Transaction Type:
ZREG - Regular Vehicle TransactionJob Card Open Date:
10/31/2011Repair completion date:
10/31/2011Process Date:
11/04/2011Financial Year/Month:
11/04/2011

Serialized Part ID:

Causal Part Number:
000000000025755765

Pre-Repair Approval No:

Add-On Repair:

Labour Operation:

Z2017 - BRAND QUALITY EXPENSE - CARS, TRUCKS AND POWERTRAIN

Transaction Version Information:Process Status:
ACC/PAID

Correction Required:

Labour Operation Dependency
Code:

Reference Number:

Transaction Category:
WTYVersion:
2

Foreign Tourist VIN:

Tourist/Transient:

Additional Credit:

Debit:

Partial Debit:

Action Performed:

Service Advisor:
0917780823Technician:
758297045Flag Count:
0Repair Group:
29-Miscellaneous

Special Policy:

Adjustment Reason:

Field Action:

Service Contract Information:

MIC Agreement Ref Number: MIC Agreement Ref Type: MIC Part Number: MIC Assembly Code:

Transaction Amounts:

	Requested Before Tax:	Paid Before Tax:	Taxes:	Total:
Labour:	USD 58.64	USD 58.64	USD 0.00	USD 58.64
Parts & Parts Handling:	USD 184.65	USD 184.65	USD 0.00	USD 184.65
Net Items:	USD 0.00	USD 0.00	USD 0.00	USD 0.00
Deductible:				USD 0.00
Customer/Service Agent Participation:				USD 0.00
Total:	USD 243.29	USD 243.29	USD 0.00	USD 243.29

Parts Return Status:

Project ID: Request Nbr: Status: Test Results:
001105420139 No

Complaint/Cause/Correction:

Complaint:0021 - No Customer Complaint - Maintenance - FUEL FILLER NECK.. PART ON ORDER

Cause:8019 - Module/Component - Corrosion - REPLACED THE FUEL FILLER NECK DUE TO CORROSION , REPAIR PERFORMED PER BQM CALVIN WILLIAMS

Correction: - INSPECTED THE FUEL FILLER NECK AND RELATED COMPONENTS, THE TECH REPLAC ED THE FUEL FILLER NECK DUE TO CORROSION. THE REPAIR WASAPPROVED BY B RAND QUALITY MANAGER CALVIN WILLIAMS OF G VAN . PART WAS RETURN TO THE BRAND QUALITY MANAGER FOR ENGINEERINGANALYSIS.

Approvals/Rejects:

Reject Messages:

Number	Description	Type
806 400100	Valid Warranty found.	I

Approver Code:	Approver Type:	Effective Authorization:	Required Auth Code:

Comments:

GOODWILL PER BQM.

Labour:

	Requested Hours	Paid hours	Requested Amount	Paid Before Tax	Taxes	Total	Tax Rate
Base Labour Hours	0.6	0.6	USD 58.64	USD 58.64	USD 0.00	USD 58.64	USD 0.00

Parts:

Causal Part:

000000000025755765

Causal Part: Module/Component - Corrosion

Quantity	Causal Part	Causal Part Number	Description	Requested Parts Handling	Paid Parts	Paid Parts Handling	Paid Before Tax	Paid Taxes	Paid Total	Invoice Number	Part Install Date	Non-GM Part	Svc Agent Trade	Major Assembly
1	X	0000000 0002575 5765	PIPE ASM-F/TNK FIL	USD 184.65	USD 52.76	USD 184.65	USD 0.00	USD 184.65	USD 184.65					

Additional Parts Information

Battery Flag
ACD Jobber Number
SDO Ship Direct Number

ACD Batt Mths ACD Batt Code ACD Batt Date ACD Batt Fail Pur Date Service Code Trans Code Transaction Form Number

Net Item Type:

Description	Requested Amount	Paid Before Tax	Taxes	Total	Tax Rate	Invoice Number	VIN	Days	Distance

VIN History:

Flag Count	Repairing Service Agent	Transaction Number	Version	Active Version Indicator	Process Status	Job Card Number	Job Card Date	Labour Operation	Repair completion date	Total Hours	Total Parts	Total Net	Total	Debit Ind
0	115098	001105420139	2	X	ACC/PAI D	524955	10/31/201	Z2017	10/31/201	0.60	131.89	0.00	243.29	

FILTER: Service Agent = AUDIA MOTOR SALES INC
GM GLOBAL WARRANTY MANAGEMENT

GM CONFIDENTIAL

11/8/11 11:58 AM EDT

Vehicle

VIN: 1GBFH15T331 [REDACTED] CH13405	Transaction: 001105420139	Non GM Vehicle Indicator:	Delivery Type: 021
Odometer: 123595	Assigned Warranty Start Date: 12/17/2003	Business Unit: GM - US	Repairing BAC: 115098-JOE LUNGHAMER CHEVROLET, INC.

Transaction Header Information:

Job Card: 524955	Job Card Line: 1	Transaction Type: ZREG - Regular Vehicle Transaction	
Job Card Open Date: 10/31/2011	Repair completion date: 10/31/2011	Process Date: 11/04/2011	Financial Year/Month: 11/04/2011
Serialized Part ID:	Causal Part Number: 000000000025755765	Pre-Repair Approval No:	Add-On Repair:

Labour Operation:
Z2017 - BRAND QUALITY EXPENSE - CARS, TRUCKS AND POWERTRAIN

Transaction Version Information:

Process Status: ACC/PAID	Correction Required:	Labour Operation Dependency Code:	Reference Number:
Transaction Category: WTY	Version: 2	Foreign Tourist VIN:	Tourist/Translent:
Additional Credit:	Debit:	Partial Debit:	Action Performed:
Service Advisor: 0917780823	Technician: 758297045	Flag Count: 0	Repair Group: 29-Miscellaneous
Special Policy:	Adjustment Reason:	Field Action:	

Service Contract Information:

MIC Agreement Ref Number: MIC Agreement Ref Type: MIC Part Number: MIC Assembly Code:

Transaction Amounts:

	Requested Before Tax:	Paid Before Tax:	Taxes:	Total:
Labour:	USD 58.64	USD 58.64	USD 0.00	USD 58.64
Parts & Parts Handling:	USD 184.65	USD 184.65	USD 0.00	USD 184.65
Net Items:	USD 0.00	USD 0.00	USD 0.00	USD 0.00
Deductible:				USD 0.00
Customer/Service Agent Participation:				USD 0.00
Total:	USD 243.29	USD 243.29	USD 0.00	USD 243.29

Parts Return Status:

Project ID: Request Nbr: Status: Test Results:
001105420139 No

Complaint/Cause/Correction:

Complaint:0021 - No Customer Complaint - Maintenance - FUEL FILLER NECK.. PART ON ORDER

Cause:8019 - Module/Component - Corrosion - REPLACED THE FUEL FILLER NECK DUE TO CORROSION , REPAIR PERFORMED PER BQM CALVIN WILLIAMS

Correction: - INSPECTED THE FUEL FILLER NECK AND RELATED COMPONENTS, THE TECH REPLAC ED THE FUEL FILLER NECK DUE TO CORROSION. THE REPAIR WASAPPROVED BY B RAND QUALITY MANAGER CALVIN WILLIAMS OF G VAN . PART WAS RETURN TO THE BRAND QUALITY MANAGER FOR ENGINEERINGANALYSIS.

Approvals/Rejects:

Reject Messages:

Number	Description	Type
806 400100	Valid Warranty found.	I

Approver Code:	Approver Type:	Effective Authorization:	Required Auth Code:

Comments:

GOODWILL PER BQM.

Labour:

	Requested Hours	Paid hours	Requested Amount	Paid Before Tax	Taxes	Total	Tax Rate
Base Labour Hours	0.6	0.6	USD 58.64	USD 58.64	USD 0.00	USD 58.64	USD 0.00

Parts:

Causal Part:

000000000025755765

Causal Part: Module/Component - Corrosion

Quantity	Causal Part	Causal Part Number	Description	Requested Parts Handling	Paid Parts	Paid Parts Handling	Paid Before Tax	Paid Taxes	Paid Total	Invoice Number	Part Install Date	Non-GM Part	Svc Agent Trade	Major Assembly
1	X	0000000 0002575 5765	PIPE ASM-F/TNK FIL	USD 184.65	USD 52.76	USD 184.65	USD 184.65	USD 0.00	USD 184.65					

Additional Parts Information

Battery Flag
ACD Jobber Number
SDO Ship Direct Number

ACD Batt Mths ACD Batt Code ACD Batt Date ACD Batt Fail Pur Date Service Code Trans Code Transaction Form Number

Net Item Type:

Description	Requested Amount	Paid Before Tax	Taxes	Total	Tax Rate	Invoice Number	VIN	Days	Distance

VIN History:

Flag Count	Repairing Service Agent	Transaction Number	Version	Active Version Indicator	Process Status	Job Card Number	Job Card Date	Labour Operation	Repair completion date	Total Hours	Total Parts	Total Net	Total	Debit Ind
0	115098	001105420139	2	X	ACC/PAI D	524955	10/31/201	Z2017	10/31/201	0.60	131.89	0.00	243.29	

FILTER: Service Agent = AUDIA MOTOR SALES INC
GM GLOBAL WARRANTY MANAGEMENT

GM CONFIDENTIAL

11/8/11 11:58 AM EDT



MARK IV AUTOMOTIVE
5755765





FRS
26755765

01/09/12
08:47:47



PE11-040

GM

2-10-2012

Q10,

Explanation_PN_25746083



Re: GMT 610 Ir Documentation 

John M Hamilton to: Susan Phillips
Cc: Benjamin F. Nash, Linda Regnier-Sebastian

01/30/2012 08:07 AM

From: John M Hamilton/US/GM/GMC
To: Susan Phillips/US/GM/GMC@GM
Cc: Benjamin F. Nash/US/GM/GMC@GM, Linda Regnier-Sebastian/US/GM/GMC@GM

Susan -

There is no 2D in the system for 25746083 and the 3D is the same as PN 25755765 with the exception of the 1 tie strap at the base of the convoute.

Thank You,

John M. Hamilton
Design Release Engineer - Fuel Fill Systems
BFO - Fuel Filler Pipes
Cell: (586) 907-4815
E-mail: john.m.hamilton@gm.com

Susan Phillips Thank you, John. I looked at the folder with the... 01/27/2012 04:01:54 PM

From: Susan Phillips/US/GM/GMC
To: John M Hamilton/US/GM/GMC@GM
Cc: Benjamin F. Nash/US/GM/GMC@GM, Linda Regnier-Sebastian/US/GM/GMC@GM
Date: 01/27/2012 04:01 PM
Subject: Re: GMT 610 Ir Documentation

Thank you, John.

I looked at the folder with the 2D drawings. Do you have a drawing available for PN 25746083, the early 2003 tube without the lower tie strap?

Susan Phillips
GM Product Investigations

Vehicle Engineering Center, 2K4-04
30001 Van Dyke
Warren, Michigan, 48090-9020

PHONE 586-907-3057

John M Hamilton	These are 3D math files. You probably have n...	01/27/2012 03:11:04 PM
Susan Phillips	John, We cannot open the files with the ".jt" ex...	01/27/2012 03:04:08 PM
John M Hamilton	Susan and Joe - The 610 IR data that Linda an...	01/25/2012 05:03:05 PM