

INFORMATION Redacted PURSUANT TO THE FREEDOM OF
INFORMATION ACT (FOIA), 5 U.S.C . 552(B)(6)





CASE #
9027763

ED SCHMIDT
Jeep

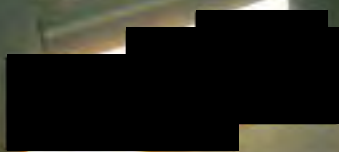



CASE #

3.7L



CASE #



THIS PAPER
IS TO BE USED TO
RECORD THE
POSITION OF
EVIDENCE
MARKERS
PLACED IN THE
VEHICLE
FOR INVESTIGATION
OF THE
ACCIDENT
AND TO BE
RETURNED TO THE
POLICE DEPARTMENT
FOR RECORDING



3052

CASE #
[REDACTED]

CASE #

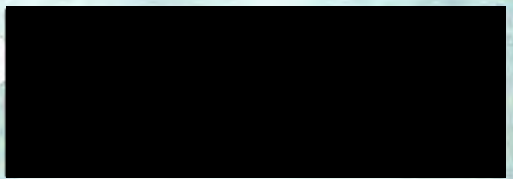

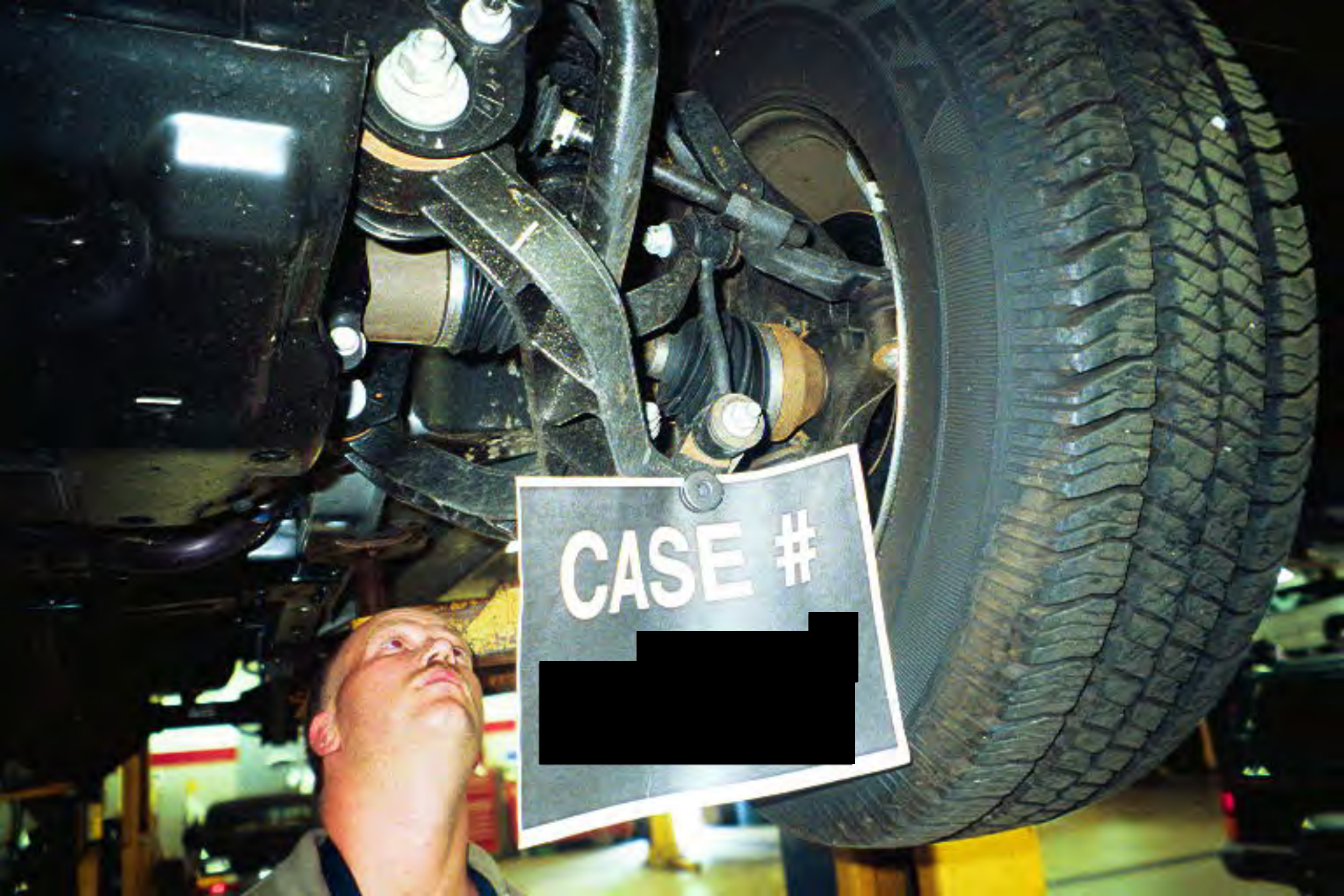

CASE #



CASE #

Replacement Vehicle Worksheet

CAIR # 9027763

VIN # 1J4GL48K72W

Owner Name: MR.

New Vin 1J4GL48K42W

USAGE FEE

Mileage 0 X \$0.00 = \$0.00
(# of miles) (cost/mile)

AND/OR

Purchase \$0.00 X 0 Miles = \$0.00
 Price 100,000
(insert either 100,000 or 120,000)

AND/OR

Mileage Offset Calculation
(Purchase Price * Miles / (100,000 or 120,000)) * 50%

\$0.00 X 0
100,000
 = \$0.00 X 50% = \$0.00
(Usage Fee) (Offset)

AND/OR

Flat Usage Fee \$0.00

A. TOTAL USAGE FEE \$0.00

MSRP CALCULATION

MSRP (New Vin) \$23,000.00

AfterMarket Accessories / Conversion
(when added at customer expense)

\$0.00
\$0.00
\$0.00

1. Total MSRP Value (New Vin) \$23,000.00

MSRP (Old Vin) \$23,000.00

AfterMarket Accessories / Conversion
(only if items are not added to new Vin)

\$0.00
\$0.00
\$0.00

2. Total MSRP Value (Old Vin) \$23,000.00

B. MSRP DIFFERENCE (1 - 2) 0

C. OWNER CONTRIBUTION TO VEHICLE COST (A + B) \$0.00

REMARKS

Mileage fee waived, please refer to CAIR line 029.

Old Vin 1J4GL48K72W

OWNER'S COLLATERAL COSTS

Taxes \$0.00
 License & Title Fees \$0.00
 Doc Fees \$0.00
 Damage (Requires Estimate) \$0.00
 Service Contract \$0.00
 Other \$0.00

D. TOTAL COLLATERAL COSTS \$0.00

VEHICLE COST

New Vehicle Invoice Cost \$21,983.00
 Less Holdback \$672.00
 Subtotal \$21,311.00
 AfterMarket Accessories / Conversion
(items added to new vin only)

\$0.00
\$0.00
\$0.00
 Owner Contribution (Step C) (+/-) \$0.00

E. TOTAL VEHICLE COST \$21,311.00

COLLATERAL COSTS

Taxes \$3.13
 License & Title Fees \$15.00
 Doc Fees \$50.00
 Service Contract \$0.00
 Dealer Handling \$300.00
 Other \$0.00
 Owner Contribution (Step D) (+/-) \$0.00

F. TOTAL COLLATERAL COSTS \$368.13

TOTAL AMOUNT REQUESTED (E + F) \$21,679.13

OWNER CHECK TO DEALER (C + D) \$0.00

DAIMLERCHRYSLER REACQUIRED VEHICLE BUYBACK AND DISPOSAL SYSTEM
Approved Buyback Package -- 1/9/2002 (con't)

CAIR [REDACTED]

VIN 2W [REDACTED]

HISTORY

Approval History

Check Request

Approved -- 1/9/02 11:11:58 AM (Edward J Janke)
Submitted for Approval -- 01/09/2002 8:02:58 AM (Vanessa Kibble)
Submitted for Review -- 01/08/2002 4:15:24 PM (Marne Ellis)
1/9/02 2400038817 - Ed Schmidt Jeep \$21679.13

Original Selling Dealer Information

Dealer: 26571

[REDACTED]

PERRYSBURG, OH [REDACTED]

Main Number: [REDACTED]

DATE 09/05/01 X210170T ACCTS RECEIVABLE VEHICLE INQUIRY TIME 12:13:37

VEHICLE FOUND ON VEHICLE DB

VIN - 1J4GL48K72W [REDACTED] PROD STATUS - KZ VON/TON - 61766521 AR TYPE - FIRM
BUILT DATE 060901 STATUS DATE 061201 INVOICE DATE 060801 SOLD DATE 070201
SOLD TO - 42 26571 INVOICE TO - 42 26571 SHIP TO - 26571 M0714 2607

DIVRSN/COLL INV#	CI DATE	CI CANCELL DATE
REVENUE		COST
BASE VEHICLE -	16,739.00	BASE VEHICLE - 0.00
OPTIONS -	4,039.00	OPTION COST - 0.00
GROUP FUNDS -	620.00	TIRE TAX - 0.00
DESTINATION -	585.00	DESTINATION - 0.00
TOTAL INVOICE -	21,983.00	HANDLING - 0.00
TOTAL MSRP -	23,000.00	PLT SPEC EQUIP- 0.00
		BODY VENDOR - 0.00
		TOTAL COST - 0.00

MEMO INFO :
 HOLD BACK - 672.00-
 EMPLOYEE NVP - 20,671.00

USE PF1 FOR PRINTED OUTPUT PF8 TO OBTAIN "HELP" INFORMATION
 PF10 TO RETURN TO PRIOR MENU PF11 TO RETURN TO PRIMARY MENU

NEXT INQUIRY VIN OR VON/TON CARLINE YEAR

DAIMLERCHRYSLER MOTORS CORPORATION INVOICE

1664-A
 PLANT ZONE DEALER VEHICLE ID NO. INVOICE NO. INVOICE DT
 TOLEDO NORTH 42 26571 1J4GL48K42W [REDACTED] [REDACTED] 06/18/01

SHIP TO: ED SCHMIDT JEEP EAGLE
 PO BOX 111
 PERRYSBURG OH 43551

IGN KEY M1248
 TRK KEY 1248
 ACC KEY 3432
 2462-01-6218

SOLD TO: ED SCHMIDT JEEP EAGLE
 PO BOX 111
 PERRYSBURG OH 43551

SHIPPING WT. 4135

PAID FOR BY: HUNTINGTON NATIONAL BANK
 CREDIT SALE XX CASH SALE

SAE HP 32.2
 000-044000-00

BODY & EQUIP.	DESCRIPTION	FACTORY WHOLESALE PRICE
MJH74	JEEP LIBERTY SPORT	16,944.00
PU2	Woodland Brown Satin Glow	
MSL5	Seats - Cloth High-Back Bucket	NO CHARGE
UG4	Transmission-Multi-Speed Auto, 45RFE	743.00
EKG	Engine - 3.7L Power Tech V6	765.00
CEG	Glass - Deep Tint Sunscreen	243.00
CTS	Mirrors - Power Heated, Fold-Away	45.00
LNJ	Fog Lamps	108.00
MHM	Speed Control	270.00
FBK	Radio-AM/FM Compact Disc w/Chgr Ctrl	113.00
TSN	Tires - P235/70R16 OWL All Terrain	221.00
YDH	DaimlerChrysler Owner Loyalty Mail	20.00
YGE	5 Additional Gallons Of Gas	8.00
2TB	Customer Preferred Package 2TB	
27B	Customer Preferred Package 27B	2,201.00
3VD	Customer Preferred Discount	698.00
E25	DETROIT OUTSTATE - DAA	205.00
L25	DETROIT OUTER - PPA/EB-PF	210.00
309	DESTINATION CHARGE HB 67200	585.00

02.3182
 3miles
 06.27.01

JUN 27 2001

MDH # 061612
 EP 20671

MSRP RETAIL TOTAL 23,000.00 TOTAL 21,983.00
 ORIGINAL INVOICE

HIS VEHICLE IS MANUFACTURED TO MEET SPECIFIC UNITED STATES REQUIREMENTS. THIS VEHICLE IS NOT MANUFACTURED FOR SALE OR REGISTRATION OUTSIDE OF THE UNITED STATES.

09/05/01

08:26

ED SCHMIDT AUTO GROUP -> 214-634-2263

SEP-4-01 12:53;

NO. 729 003

PAGE 2/2

VEHICLE ORDER



P.O. Box 111 • 25875 Dixie Hwy. Rte. 25 • (419) 874-4931
PERRYBURG, OHIO 43652-0111
schmidt.com

STOCK NO.

(12-3154

OTL NO. 87923

JUN 30 1981

PURCHASER'S NAME DATE

CITY STATE OH PHONE MICHAEL J FUJAWA

SALESMAN'S NAME

VEHICLE USE ENTER MY ORDER FOR ONE NEW USED CAR TRUCK DEMONSTRATOR AS FOLLOWS:

VEHICLE YEAR 2002 MAKE JEEP MODEL LIBERTY BODY TYPE 4DR COLOR BR SILVER TRIM DK FLATE G

MILEAGE APPROXIMATE ON ODOMETER ODOMETER MILEAGE IS ACCURATE PROMPTER MILEAGE IS NOT ACCURATE

Table with columns for ADDITIONAL EQUIPMENT and CASH PRICE OF VEHICLE

Table with columns for DEPOSIT RECEIPT, NEGATIVE EQUITY, CASH PRICE OF VEHICLE, HAS BEEN RAISED TO COVER NEGATIVE EQUITY IN TRADE-IN VEHICLE, SELLING PRICE, DOCUMENTARY FEE

Table with columns for TRADE-IN AND OTHER CREDITS, TRADE-IN ALLOWANCE, BALANCE OWED ON TRADE, CONTRACTUAL DISCLOSURE STATEMENT FOR USED VEHICLE ONLY, COUNTY, LICENSE & TITLE, OTHER, TOTAL, TOTAL CREDIT, TRADE-IN STOCK NO., YEAR, MAKE, MOO., BODY TYPE, VIN, MILEAGE, BALANCE DUE

ALL WARRANTIES, IF ANY, BY A MANUFACTURER OR SUPPLIER OTHER THAN DEALER ARE THEIRS, NOT DEALER'S, AND ONLY SUCH MANUFACTURER OR OTHER SUPPLIER SHALL BE LIABLE FOR PERFORMANCE UNDER SUCH WARRANTIES. UNLESS DEALER FURNISHES BUYER WITH A SEPARATE WRITTEN WARRANTY OR SERVICE CONTRACT MADE BY DEALER ON ITS OWN BEHALF, DEALER HEREBY DISCLAIMS ALL WARRANTIES, EXPRESS OR IMPLIED, INCLUDING ANY IMPLIED WARRANTIES OF MERCHANTABILITY OF FITNESS FOR A PARTICULAR PURPOSE: (A) ON ALL GOODS AND SERVICES SOLD BY DEALER, AND (B) ON ALL USED VEHICLES WHICH ARE HEREBY SOLD "AS IS-NOT EXPRESSLY WARRANTED OR GUARANTEED."

IF THIS CONTRACT IS A FINANCE SALE ARRANGED BY ED SCHMIDT PONTIAC, GMC TRUCK, INC., THEN THIS ORDER IS NOT VALID UNTIL A FINANCE DISCLOSURE STATEMENT IS FILLED IN AND SIGNED BY THE BUYER.

THIS ORDER IS NOT VALID UNLESS SIGNED AND ACCEPTED BY DEALER OR HIS AUTHORIZED REPRESENTATIVE. ACCEPTED BY PURCHASER DATE 06/30/01. SIGNED PURCHASER

APPROVED DEALER OR AUTHORIZED REPRESENTATIVE. APPROVED AND SIGNATURE (PUB) PURCHASER

09/05/01

08:26

ED SCHMIDT AUTO GROUP → 214-634-2263

NO. 729

002

FAST CARE,

ed schmidt

THEN CARS

PONTIAC • GMC • JEEP • VOLVO • SAAB • VOLKSWAGEN

P.O. Box 111 • 26875 Dixie Hwy. Rte. 25 • (419) 874-4331
PERRYSBURG, OHIO 43552-0111

VEHICLE WORKSHEET

STOCK NO. 02-3182

CTL. NO. _____

PURCHASER'S NAME _____

DATE 9/5/01

STREET ADDRESS _____

PHONE _____

CITY Toledo

STATE OHIO

ZIP _____

SALESMAN'S NAME M. KUTAJA

PLEASE ENTER MY ORDER FOR ONE

NEW

USED

CAR

TRUCK

DEMONSTRATOR

AS FOLLOWS:

YEAR	MAKE	MODEL	BODY TYPE	COLOR	TRIM
2002	Jeep	LIBERTY	SPORT 4x4	WOODLAND BROWN	Cloth
MVI OR SERIAL NO	1J4GL48K42W		927	MILEAGE APPEARING ON ODOMETER	<input checked="" type="checkbox"/> ODOMETER MILEAGE IS ACCURATE <input type="checkbox"/> ODOMETER MILEAGE IS NOT ACCURATE
ADDITIONAL EQUIPMENT			CASH PRICE OF VEHICLE		
SUB-TOTAL					
DEPOSIT RECEIPT:		NEGATIVE EQUITY:			
PURCHASE OPTION GOOD UNTIL <u>1/1</u>		CASH PRICE OF VEHICLE			
DEPOSIT IS NOT REFUNDABLE UNLESS BUYER IS UNABLE TO OBTAIN FINANCING. IF THIS DEPOSIT IS IN CONNECTION WITH THE SPECIAL ORDER OF A VEHICLE NOT IN OUR POSSESSION, IT IS NOT REFUNDABLE UNLESS VEHICLE IS UNDELIVERABLE OR DELIVERED AT A HIGHER PRICE THAN QUOTED.		HAS BEEN RAISED TO COVER NEGATIVE EQUITY IN TRADE-IN VEHICLE.			
		SELLING PRICE		23000 00	
		DOCUMENTARY FEE		50 00	
TRADE-IN AND OTHER CREDITS:		SUB-TOTAL		23050 00	
TRADE-IN ALLOWANCE	23000 00		TAXABLE TOTAL	50 00	
BALANCE OWED ON TRADE			X 6.74 % SALES TAX	3 13	
BALANCE OWED TO:			COUNTY	<u>LUCAS</u>	
NET EQUITY			LICENSE & TITLE	15 00	
DEPOSIT			OTHER		
CASH ON DELIVERY			TOTAL	23068 13	
OTHER			TOTAL CREDIT	23000 00	
TOTAL CREDIT	23000 00		BALANCE DUE	68 13	
TRADE-IN STOCK NO.	YEAR	MAKE	MOD	MILEAGE	
	2002	Jeep	LIBERTY	388	

This Vehicle Worksheet is not a valid contract.

The vehicle order, signed by an authorized representative of the dealership, is the valid contract.

ACCEPTED BY PURCHASER

DATE _____

SIGNED _____

PURCHASER

INCENTIVE RESOLUTION AGREEMENT

Dealer: [Redacted]
Perrysburg, OH [Redacted]
Dealer Code: 26571

In mutual resolution of the complaint of [Redacted] regarding his/her vehicle, VIN:
1J4GL48K72W [Redacted], we have agreed to place [Redacted] into another vehicle, VIN:
1J4GL48K42W [Redacted].

As part of this transaction, I understand and agree that the new vehicle, VIN:
1J4GL48K42W [Redacted] will be ineligible and disqualified from all consumer and dealer incentive
programs available. Nor will it count as a "qualifying" unit toward any dealer objective for such incentives /
programs.

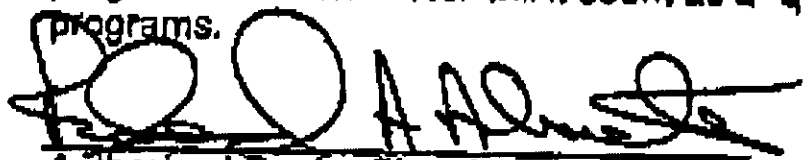
Authorized Dealer Signature
Sales Rep
Title

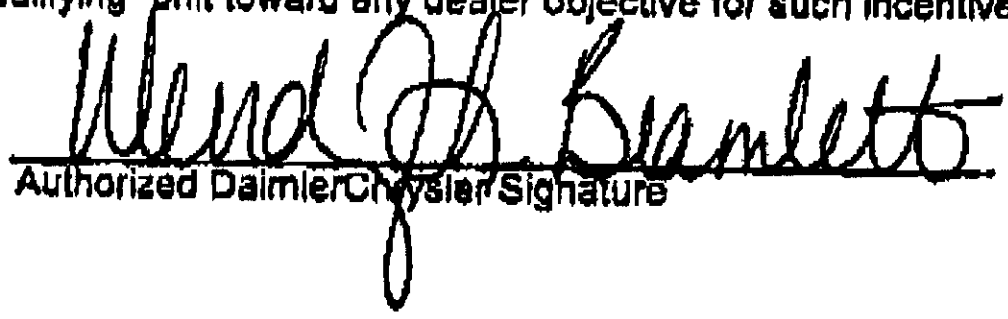
Authorized DaimlerChrysler Signature

Ed Schmidt Jeep
Dealership Name
26571
Dealer Code

ISG
Zone
91
Zone Code

2400038817

62-26
311

DaimlerChrysler Corporation

P.O. BOX 21-8004
AUBURN HILLS, MI 48321-8004

CHASE MANHATTAN BANK USA, N.A.
WILMINGTON, DELAWARE

3611-09

2400038817

COUNTER SIGNATURE

PAY
TO THE
ORDER OF

DATE

AMOUNT

1/9/02

\$21,679.13

VOID SIX MONTHS AFTER DATE OF ISSUE
NOT VALID OVER \$25000 UNLESS COUNTERSIGNED

AUTHORIZED SIGNER FOR

DaimlerChrysler Customer Center

ACCOUNT 7527

[Redacted]

Perrysburg, OH [Redacted]

[Redacted]

[Redacted Signature Line]

DaimlerChrysler Customer Center

2400038817

2400038817

Payee Name: Ed Schmidt Jeep
Memo:

Date

Amount

1/9/02

\$21,679.13

Payee Name:

[Redacted]

Memo:

Program Tracking: BYBACK

Date

Amount

Check No.

1/9/02

\$21,679.13

2400038817

Loc Account Center Description

Expense Auth.

2100 [Redacted] 0009999 1J4GL48K72W [Redacted]

9027763

21,311.00

2100 [Redacted] 0094666 1J4GL48K72W [Redacted]

9027763

368.13

42 Accident

OHIO CERTIFICATE OF TITLE

COUNTY OF HAMILTON

STATE OF OHIO

No. [REDACTED]

ORIGINAL

BUYBACK:

THIS VEHICLE WAS RETURNED TO THE MANUFACTURER BECAUSE IT MAY NOT HAVE CONFORMED TO ITS WARRANTY

ISSUE DATE
01/14/2002

IDENTIFICATION NUMBER
1J4GL48K72W [REDACTED]

YEAR
2002

MAKE
JEEP

MAKE DESCRIPTION
JEEP (MFD. AFTE

COMMENTS

PURCHASE PRICE
\$00

BODY TYPE
SW

MODEL
SPR

MODEL DESCRIPTION

CONVERSION

EXEMPT
NE

MILEAGE
61

EVIDENCE
OH [REDACTED]

MLG BRAND ACTUAL

BRAND(S) BUYBACK VEHICLE

OWNER

CINCINNATI, OH [REDACTED]

PREVIOUS OWNER

PERRYSBURG, OH [REDACTED]

LIEN DISCHARGE

Lienholder

by:

Authorized signature

date

CLERK OF COURTS LIEN CANCELLATION

by:

Deputy Clerk

date

LIEN DISCHARGE

Lienholder

by:

Authorized signature

date

CLERK OF COURTS LIEN CANCELLATION

by:

Deputy Clerk

date

WITNESS MY HAND AND OFFICIAL SEAL THIS 14th DAY OF JANUARY, 2002
(SEAL)

JAMES CISSELL
CLERK OF COURTS

COLLIERVILLE

DO NOT ACCEPT TITLE SHOWING ANY ERASURES, ALTERATIONS OR MUTILATIONS.



Predelivery Service Corporation

26115 Trowbridge
Inkster, MI 48141

Repair Order

Dealer Code 78003



Vin:	72W [REDACTED]
MileageIn:	2080
MileageOut:	2140
RO Type:	Warranty
Program Code	

RecRepair:	9/24/2001
Completion Date:	
Year:	02
Make:	Jeep
Model:	Liberty

Advisor:	1044-Esterline, Dave
CustomerName:	[REDACTED] AV
Authorization:	
DealerRoNum:	4059
PriorClaimNum	

Job 1 1295-Zelten, Paul

Cause & Cure

Concern Code:

WHILE MAKING A RIGHT
TURN- BOTH FRONT
AIRBAGS DEPLOYED

DRB TEST/ OPEN SQUIB

REPLACE AIRBAG
CONTROL MODULE

Part Name	Failed	PartNumber	Qty	BuyPrice	LOP	FC	Hours
module	<input checked="" type="checkbox"/>	56010501ae	1	\$178.50	23115001	58	0.4
					85410000		1.0

SpecialService	SpcSvcInv	LOP	Hours	Amount
Safety Inspection	131388	95121212	1.0	\$50.00

*Demoit
Auto
Action*

**IMPARTIAL SERVICES GROUP, INC.
VEHICLE PICK-UP REQUEST**

Date: September 17, 2001
To: Road One

Telephone
Fax:

248-886-0534
248-886-0538

Customer Name: [REDACTED]
Zone: 42
VIN: 1J4GL48K72W [REDACTED]
Year: 2002
Model: Jeep Liberty Sport 4X4 Sport Utility 4-Dr
Color: XXXXXX
Brake/Steering: Yes

*****ATTENTION DRIVER*****

Call 24 hours in advance before going to pick up the vehicle to insure that the contact will be available to assist you when you arrive.

Pick Up Name: [REDACTED]
Address: [REDACTED]
City: Perrysburg
State: OH
Zip Code: [REDACTED]
Telephone: [REDACTED]
Contact Name: [REDACTED]

Special Remarks:
Delivery Name: Predelivery - Detroit
Street Address: 26115 Trowbridge
City: Inkster
State: MI
Zip Code: 48141
Telephone: 313-274-0000
Contact Name: Dave Esterline

*****ATTENTION DRIVER*****

Call Road One at 248-886-0534 if you have any problems picking up this vehicle at the dealership.

Final Destination: DETROIT AUTO AUCTION

ROAD ONE USE ONLY

Date Received:	
Transportation Cost Estimate:	
Delivery Completed By:	
Special Requirments:	
Signature:	

**IMPARTIAL SERVICES GROUP, INC.
VEHICLE PICK-UP REQUEST**

Date: October 4, 2001
To: Lyn Tetreau

Telephone
Fax:

248-886-0534
248-886-0538

Customer Name: [REDACTED]
Zone: 42
VIN: 1J4GL48K72W [REDACTED]
Year: 2002
Model: Jeep Liberty Sport 4X4 Sport Utility 4-Dr
Color: XXXXXXX
Brake/Steering: Yes

*****ATTENTION DRIVER*****

Call 24 hours in advance before going to pick up the vehicle to insure that the contact will be available to assist you when you arrive.

Pick Up Name: Predelivery - Detroit
Address: 26115 Trowbridge
City: Inkster
State: MI
Zip Code: 48141
Telephone: 313-274-0000
Contact Name: Dave Esterline

Special Remarks:
Delivery Name: Marshalling

*****ATTENTION DRIVER*****

Call Road One at 248-886-0534 if you have any problems picking up this vehicle at the dealership.

Final Destination: DETROIT AUTO AUCTION

ROAD ONE USE ONLY

Date Received:	
Transportation Cost Estimate:	
Delivery Completed By:	
Special Requirments:	
Signature:	

**IMPARTIAL SERVICES GROUP, INC.
VEHICLE PICK-UP REQUEST**

Date: January 18, 2002 Telephone 989-269-2161
To: Lyn Tetreau Fax: 989-269-2361

Customer Name: [REDACTED]
Zone: 42
VIN: 1J4GL48K72W [REDACTED]
Year: 2002
Model: Jeep Liberty Sport 4X4 Sport Utility 4-Dr
Color: XXXXXX
Brake/Steering: Yes

*****ATTENTION DRIVER*****

Call 24 hours in advance before going to pick up the vehicle to ensure that the contact will be available to assist you when you arrive.

Pick Up Name: Marshalling

Special Remarks:

Delivery Name: Detroit Auto Auction
Street Address: 20911 Gladwin
City: Taylor
State: MI
Zip Code: 48180
Telephone: 734-246-2293 Ext. 281
Contact Name: Debbie Holme

*****ATTENTION DRIVER*****

Call Road One at 989-269-2161 if you have any problems picking up this vehicle at the dealership.

Final Destination: DETROIT AUTO AUCTION

ROAD ONE USE ONLY

Date Received:	
Transportation Cost Estimate:	
Delivery Completed By:	
Special Requirments:	
Signature:	

REPLACEMENT AGREEMENT

In sole consideration of 1J4GL48K42W [redacted] I/We, [redacted] release DaimlerChrysler Motors Corporation, and its subsidiaries, dealerships, and all persons involved in the dispute resolution and vehicle repurchase or replacement transactions from all known and unknown claims, damages, costs, fees, loss of service, personal injuries and property damage related to a 2002, Jeep Liberty Sport 4X4 Sport Utility 4-Dr VIN: 1J4GL48K72W [redacted]. In return, I will transfer the ownership of the vehicle to DaimlerChrysler Motors Corporation with clear title, and will sign all papers DaimlerChrysler Motors Corporation requires to transfer the vehicle. I will return the vehicle with no original or substituted equipment missing and in an undamaged condition, except for normal wear and tear and any previously alleged defects.

I agree to indemnify and hold the above parties harmless from all further claims, costs or expenses relating to this claim. I expressly agree that the only consideration I will receive is that listed above and that DaimlerChrysler Motors Corporation has made no other promises to me. I accept the consideration listed above as full satisfaction of this claim.

Except as permitted by law, I agree not to talk about the details of this agreement and release to anyone. I understand that all the above parties deny any liability for this claim.

I fully understand and freely sign this release.

Date: 9-13, 2001

[redacted]

Signature

[redacted]

Signature

Witness Signature



2777 Stemmons Freeway . Suite 1425
Dallas, TX 75207
(214) 634-9100
Fax: (214) 634-2262

September 17, 2001

To: Dave Esterline
Co: Predelivery - Detroit
Fax: 313-274-5759

From: Darla Rollins
Zone: 42
Telephone: 214-634-9100

BUYBACK VEHICLE:

Customer Name: [REDACTED]
Vehicle VIN: 1J4GL48K72W [REDACTED]
Model: JEEP LIBERTY SPORT 4X4 SPORT UTILITY
4-DR
Color: XXXXXX
Year: 2002
State: OH

Regarding the repair of the above referenced vehicle, the customer complained of the following:

1. While Making A Right Turn Both Front Airbags Deployed.

Please attempt to have the vehicle repaired by: 10/17/2001

- If you are unable to Repair any of the above complaints, please notify ISG immediately.
- Please call before completing any repairs not related to the problems listed on this sheet.
- Once the repairs have been completed, please fax a copy of the R.O to 214-634-2262.
- If you are unable to meet the requested vehicle repair date or if you have any questions regarding the repair of this vehicle, please call me at 214-634-9100.

Thank you for your assistance and speedy attention to this matter.

1077

DAIMLERCHRYSLER

DISCLOSURE NOTICE

3023019

Rev. 11/98

(Check One)

[X] In an effort to promote customer satisfaction, this vehicle was repurchased by DaimlerChrysler Motors Corporation due to the problem(s) listed below.

[] This vehicle was repurchased by DaimlerChrysler Motors Corporation pursuant to consumer warranty laws due to the defect(s)/nonconformity(ies) listed below.

VIN	YEAR	MAKE	MODEL
1J4GL48K72W [REDACTED]	02	JEEP	LIBERTY SPORT 4X4 SPORT UTILITY 4-DR

Reported Problem(s):

- While making a right turn both front airbags deployed.
-
-
-
-

Date Repaired or Other Comments:

- 10/1/01-Replace airbag control module.
-
-
-
-

Additional Information:

J. Selma, Agent 02/21/2002
 DaimlerChrysler Motors Corporation Representative Signature Date

Al Hampton - Agent 02/21/2002
 Auction Representative Signature/Title Date

The signature of the dealer representative constitutes agreement by the dealer that disclosure of the above information will be made to the retail customer at the time of sale of this vehicle as provided by law in the state in which it is resold. The dealer agrees to defend, indemnify, and hold harmless DaimlerChrysler Motors Corporation from all claims, causes of action, or any other liability arising from or related to the dealer's failure to make proper disclosure of the above information, whether or not disclosure is required by state or federal law. DaimlerChrysler Motors Corporation provides a supplemental Limited Warranty for a period of 12 months with unlimited mileage effective with the date of purchase or lease of this vehicle by the subsequent retail buyer. Additionally, this vehicle may be eligible for any remaining new vehicle warranty coverage.

MO Lynch Pres FEB 21 2002
 Dealer Representative Signature/Title Date

MO LYNCH 26515
 Printed Name Dealer Code

Customer Acknowledgement/Signature Date

Printed Name

NORTHERN AUTO CO INC, MI
 Dealership Name State

Street & No. City or Town and State



DAIMLERCHRYSLER

DISCLOSURE NOTICE

Rev. 11/98

(Check One)

In an effort to promote customer satisfaction, this vehicle was repurchased by DaimlerChrysler Motors Corporation due to the problem(s) listed below.

This vehicle was repurchased by DaimlerChrysler Motors Corporation pursuant to consumer warranty laws due to the defect(s)/nonconformity(ies) listed below.

VIN	YEAR	MAKE	MODEL
1J4GL48K72W [REDACTED]	02	JEEP	LIBERTY SPORT 4X4 SPORT UTILITY 4-DR

Reported Problem(s):

- While making a right turn both front airbags deployed.
-
-
-
-

Date Repaired or Other Comments:

- 10/1/01-Replace airbag control module.
-
-
-
-

Additional Information: _____

J. Selma, Agent

02/21/2002

DaimlerChrysler Motors Corporation Representative Signature Date

At Hampton - Agent

02/21/2002

Auction Representative Signature/Title Date

The signature of the dealer representative constitutes agreement by the dealer that disclosure of the above information will be made to the retail customer at the time of sale of this vehicle as provided by law in the state in which it is resold. The dealer agrees to defend, indemnify, and hold harmless DaimlerChrysler Motors Corporation from all claims, causes of action, or any other liability arising from or related to the dealer's failure to make proper disclosure of the above information, whether or not disclosure is required by state or federal law. DaimlerChrysler Motors Corporation provides a supplemental Limited Warranty for a period of 12 months with unlimited mileage effective with the date of purchase or lease of this vehicle by the subsequent retail buyer. Additionally, this vehicle may be eligible for any remaining new vehicle warranty coverage.

M O Lynch

Dealer Representative Signature/Title Date

M O LYNCH Pres.

Printed Name Dealer Code

NORTHERN AUTO CO INC, MI
Dealership Name State

[REDACTED]

Customer Acknowledgment/Signature Date

4/4/02

Printed Name

[REDACTED] Hillman MI
Street & No. City or Town and State





30700 Telegraph Road - Suite 4566

Warren, Michigan 48025-4532

Case 9027763 Phone (248) 642-3232

Vin # 1J4GL48K72W (248) 642-4558

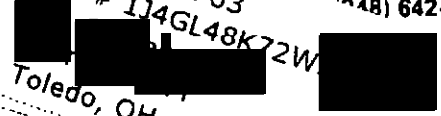

Facsimile Cover Sheet

DaimlerChrysler Vehicle Investigation

Toledo, OH 43608

Owner:	[Redacted]
EAA No:	DF01-0441039
CAIR No:	[Redacted]

HOT!

Transmitting	2	pages
If transmission not complete, please call the above phone number.		

To:	Fred Warbath
Phone No:	
Fax No:	330-725-2608

From:	Tina Martin
Date Faxed:	8-17-01
Due Date:	ASAP, please

Please acknowledge promptly by FAX or phone.

Receipt of CAIR and Accepting case for investigation YES NO DATE 8/18

Fax Coversheet for DaimlerChrysler (Service Associate Use Only)
(also fax to EAA for closure)

Closure Date: 8/20 6 DaimlerChrysler Fax Number: 248-512-8748

Number of pages (including cover) TO:

<input type="checkbox"/> Bennis (248) 944-7036	<input type="checkbox"/> Martell (248) 944-7038
<input checked="" type="checkbox"/> Bott (248) 944-7056	<input type="checkbox"/> Mucci (248) 944-7039
<input type="checkbox"/> Gilbert (248) 944-7037	<input type="checkbox"/> Porterfield (248) 944-7134

Comments: Tina - likely Tuesday AM. There was a phone message at my house from Jay that Chrysler Engineering was there Friday 8/17 so that somewhat takes the heat off



Confidential Preliminary Vehicle Investigation Report

REF [Redacted]

YEAR 02	MODEL Jeep Liberty	VEHICLE IDENTIFICATION NUMBER 1J4GL48K72W	ODOMETER 20,780	M.D.H. 06/07/22	DELIVERY DATE 6/30/01
NAME [Redacted]		ADDRESS/LOCATION [Redacted]			
CITY Toledo	STATE OH	BUSINESS PHONE [Redacted]	HOME PHONE [Redacted]		
SELLING DEALER NAME Ed Schmidt	ZONE 42	DLR. CODE 26571	CITY Perrysburg	STATE OH	
CHRYSLER REPRESENTATIVE - PRINT Fred Harbath EAA	ZONE Medina OH	PHONE (330) 725-5547	REPAIR ESTIMATE None Made		

INTERVIEW

INTERVIEW WITH: <input checked="" type="checkbox"/> DRIVER <input type="checkbox"/> OWNER <input type="checkbox"/> OTHER	NAME [Redacted]	INTERVIEW DATE 08/19/01	DATE OF INCIDENT 08/16/01	TIME OF INCIDENT 8:00 AM	INSPECTION DATE 08/20/01
---	--------------------	----------------------------	------------------------------	-----------------------------	-----------------------------

DESCRIPTION OF EVENT. (INCLUDING WEATHER CONDITIONS AND ROAD SURFACE)

- Driver's and/or occupant's description of incident
- What? When? Where? How?
- Exact order of events
- Did this happen before?

Pulling out of a video store and both bags went off at the same time

Sore arm

Personal Injury: Were there Personal Injuries? Yes No If yes, complete section "L."

IMPORTANT: SHOW TO NO ONE. DRAW NO CONCLUSIONS

- DIRECTIONS:
- FILL OUT UPPER PART OF FC
 - FOR "FIRE" USE FORM 84-130
 - FOLLOW INSTRUCTIONS FOR
 - FOLLOW INSTRUCTIONS FOR
 - ATTACH ANY ADDENDUMS TO

Case 9027763
 Vin # 1J4GL48K72W [Redacted]
 [Redacted]
 Toledo, OH [Redacted]

- COMMENTS:
- NOTE ANY MISSING COMPONENTS AND WHO REMOVED THEM.
 - NOTE ANY AFTERMARKET EQUIPMENT INSTALLED AND BY WHOM.

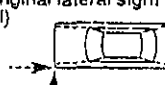
ALLEG.	PHOTOGRAPH REQUIRED	INFORMATION	EVALUATION
General	<input type="checkbox"/> From center of vehicle front every 45 degrees (6 total) <input type="checkbox"/> If crash damaged — perspective from every corner of vehicle down both original lateral sight lines. (8 total)  <input type="checkbox"/> Send neg. & 2 sets of prints	<input type="checkbox"/> Police report <input type="checkbox"/> Vehicle service file <input type="checkbox"/> Any reports/photos by others <input type="checkbox"/> Location of inspection Ed Schmidt 26875 N. Dixie Hwy Perrysburg OH 43552 419-874 4331 Dennis Kinney SM	<input type="checkbox"/> Driver's and/or occupant's description of incident <input type="checkbox"/> What? When? Where? How? <input type="checkbox"/> Exact order of events <input type="checkbox"/> Did this happen before? <input type="checkbox"/> Complete exterior damage diagram and measurements on last page.
Airbag(s)	<input type="checkbox"/> Steering Wheel <input type="checkbox"/> Airbag(s) <input type="checkbox"/> Knee Blockers <input type="checkbox"/> All possible body contact areas <input type="checkbox"/> All code readings using DRB II As found dash air bag check light is OK	<input type="checkbox"/> Record: <input type="checkbox"/> Was Airbag deployed? Driver <input checked="" type="checkbox"/> Yes <input type="checkbox"/> No Passenger <input checked="" type="checkbox"/> Yes <input type="checkbox"/> No <input type="checkbox"/> Type of Steering Wheel <input checked="" type="checkbox"/> Tilt <input type="checkbox"/> Std. <input type="checkbox"/> Condition of Steering Wheel Good <input type="checkbox"/> Condition of Steering Wheel Mounting (measure column collapse) Normal	<input type="checkbox"/> Evidence of tampering or disassembly? <input type="checkbox"/> Yes <input checked="" type="checkbox"/> No <input type="checkbox"/> Use DRB II <input type="checkbox"/> Record Existing Readings 1. See Attached 2. RO <input type="checkbox"/> Record Stored Readings 1. See Attached 2. RO 3. _____ <input type="checkbox"/> Important: DO NOT ERASE DRB II READINGS. PN 56010501 AE Ver 5.3 DRB Check by Ed Schmidt RO 5350581d 8/20/01 paid by F. Harbath EAA for Chrysler Corp

Confidential

REF. # 9027763

ALLEG.	PHOTOGRAPH REQUIRED	INFORMATION	EVALUATION
C	<input type="checkbox"/> Accelerator Pedal <input type="checkbox"/> Throttle Cable <input type="checkbox"/> Return Springs <input type="checkbox"/> Floor Mats	<input type="checkbox"/> Describe any Accelerator Pedal interference with Carpet/Mat 	<input type="checkbox"/> DRB II Tests <input type="checkbox"/> Disconnect Cable at Throttle Body/Carburetor lever; operate: <input type="checkbox"/> Lever <input type="checkbox"/> Cable <input type="checkbox"/> Any restricted motion? <input type="checkbox"/> Yes <input type="checkbox"/> No <input type="checkbox"/> If safe and permitted to drive - attempt to duplicate and check Service Brakes at reported speed.
D	<input type="checkbox"/> Items in Information Block.	<input type="checkbox"/> Check and record Brake Fluid Level. _____ <input type="checkbox"/> Check and record if Vacuum Hose is connected. <input type="checkbox"/> Yes <input type="checkbox"/> No <input type="checkbox"/> Check and record for Brake Line Leaks. <input type="checkbox"/> Yes <input type="checkbox"/> No <input type="checkbox"/> Pull Wheels, check Linings and record condition. <input type="checkbox"/> Check Brake Pedal, does it set firm? <input type="checkbox"/> Yes <input type="checkbox"/> No <input type="checkbox"/> Check operation of Parking Brake. <input type="checkbox"/> Check operation of ABS System.	With Engine off: <input type="checkbox"/> Apply Brake fully 3 or 4 times. <input type="checkbox"/> With light force held to Pedal, start the Engine. <input type="checkbox"/> Note reaction of Pedal and record: _____ <input type="checkbox"/> ABS System DRB II test readouts _____ _____
E	<input type="checkbox"/> Complete Steering System Including as required: • Rack & Pinion • Linkage • C/V & Universal Joints • Column • Belts & Pulleys	<input type="checkbox"/> Record if: <input type="checkbox"/> Manual Steering <input type="checkbox"/> <input type="checkbox"/> Check Fluid Level _____ <input type="checkbox"/> Record if Drive Belt is tight <input type="checkbox"/> Check for Hose/System _____ <input type="checkbox"/> Check condition of Steering Linkage/Column, record deformation or loose connection. _____ _____ _____	<input type="checkbox"/> Unlock key and turn Wheels fully right and left. <input type="checkbox"/> start Engine and turn Wheels full left.
F	<input type="checkbox"/> Entire Transmission with pictures and closeup of leaks, if any.	<input type="checkbox"/> Record: Type of Transmission? <input type="checkbox"/> Auto <input type="checkbox"/> Std. How many Speeds? <input type="checkbox"/> 3 <input type="checkbox"/> 4 <input type="checkbox"/> 5 <input type="checkbox"/> Record Gear Shift Location at time of Inspection _____ <input type="checkbox"/> Run Shift Lever thru all shift positions and record "Feel of Galling" _____ <input type="checkbox"/> Is Shift Indicator properly aligned? <input type="checkbox"/> Yes <input type="checkbox"/> No	If safe and permitted to drive vehicle: <input type="checkbox"/> Drive Vehicle and record feel of Gear during each Gear Shift _____ _____ <input type="checkbox"/> Does Parking Pawl engage? <input type="checkbox"/> Yes <input type="checkbox"/> No <input type="checkbox"/> If lockup is alleged - check rotation of Transmission in all Gears. <input type="checkbox"/> Check starting ability in park and neutral. Check to see that start does not occur in other selector positions.
G	<input type="checkbox"/> Complete Engine Compartment Including as required: • Underhood Emissions Label • Engine Wiring/Connections • Vacuum Hoses • Fuel Lines • Exhaust System • Spark Plugs • Connections	<input type="checkbox"/> Record type of Spark Plugs (location of unique plugs). _____ _____ _____ _____ _____	If safe and permitted to: <input type="checkbox"/> Try to duplicate Allegation Off Hiway <input type="checkbox"/> DRB II or I/P Fault Code Test _____ _____ _____

Case 9027763
 Vin # 1J4GL48K72W
 Toledo, OH

Confidential

REF # 9027763

ALLEG.	PHOTOGRAPH REQUIRED	INFORMATION	EVALUATION								
H Seat/Shoulder Belts	<input type="checkbox"/> Overall of seat belts I/B and O/B. <input type="checkbox"/> Close ups of any irregularities on belts. <input type="checkbox"/> Shoulder Belt Pendulum <input type="checkbox"/> Latchplate wear <input type="checkbox"/> Close up of D-ring to show belt loading.	<input type="checkbox"/> Locate seat belt labels and record ALL information (Some labels are sewn to webbing, other labels are on retractor frame. Inboard seat belt labels are near floor.) <input type="checkbox"/> Record ALL information stamped on latchplate.	If allowed, function belts to insure they FUNCTION PROPERLY, note results: Do they latch? <input type="checkbox"/> Yes <input type="checkbox"/> No Do they release? <input type="checkbox"/> Yes <input type="checkbox"/> No Do they retract? <input type="checkbox"/> Yes <input type="checkbox"/> No <input type="checkbox"/> Does Inertia Pendulum System run freely? <input type="checkbox"/> Yes <input type="checkbox"/> No								
			NA								
I Seat	<input type="checkbox"/> Overall of seat <input type="checkbox"/> Close ups of damage	<input type="checkbox"/> Existing location of recliner - number of teeth from rear of sector gear to rear edge of Pawl (crayon mark location). <input type="checkbox"/> Existing location of seat adjuster (window or tooth location from rear of adjuster). <input type="checkbox"/> Existing location of head restraint (measure gap under head restraint).	<input type="checkbox"/> If allowed, adjust all functions of seat and return to original location <input type="checkbox"/> Describe functions <input type="checkbox"/> Note any irregular orientations								
			NA								
J Tires	<input type="checkbox"/> Each Tire with visible location label, insuring all Tire identification and Tread wear is documented. <input type="checkbox"/> All damaged Wheel and Rim area including impacted foreign material.	Record: <input type="checkbox"/> Tire Size <input type="checkbox"/> Brand <input type="checkbox"/> Ratings <input type="checkbox"/> DOT No. (I/B Side) <input type="checkbox"/> Rim Size <input type="checkbox"/> Tread Depth	<table border="1"> <thead> <tr> <th>Front Left</th> <th>Front Right</th> <th>Rear Left</th> <th>Rear Right</th> </tr> </thead> <tbody> <tr> <td>NA</td> <td></td> <td></td> <td></td> </tr> </tbody> </table>	Front Left	Front Right	Rear Left	Rear Right	NA			
		Front Left	Front Right	Rear Left	Rear Right						
NA											
Case 9027763 Vin # 1J4GL48K72W Toledo, OH											
K Axle Locktip	<input type="checkbox"/> Entire Axle and close up of Leaks	While on holst: <input type="checkbox"/> Rear Wheel Drive Record amount of Lateral Axle Movement on each side <input type="checkbox"/> Trans. Axle - rotate Wheels <input type="checkbox"/> Note function									
			NA								
L Occupant Contact	<input type="checkbox"/> Windshield <input type="checkbox"/> All areas of occupant contact on interior and exterior. <input type="checkbox"/> Close ups of stains, skin, hair, cloth <input type="checkbox"/> Exterior and interior damage	<input type="checkbox"/> See Seat Belt/Seats if applicable <input type="checkbox"/> Occupant contact description									
			NA								

ADDITIONAL COMMENTS

At this contact also attended by TAW + Chrysler engineering they were to remove the module to take back to pull additional information out of the module

Confidential

REF. # 9027763

Exterior Damage Diagram and

ments
 Case 9027763
 Vin # 114GL48K72W
 Toledo, OH

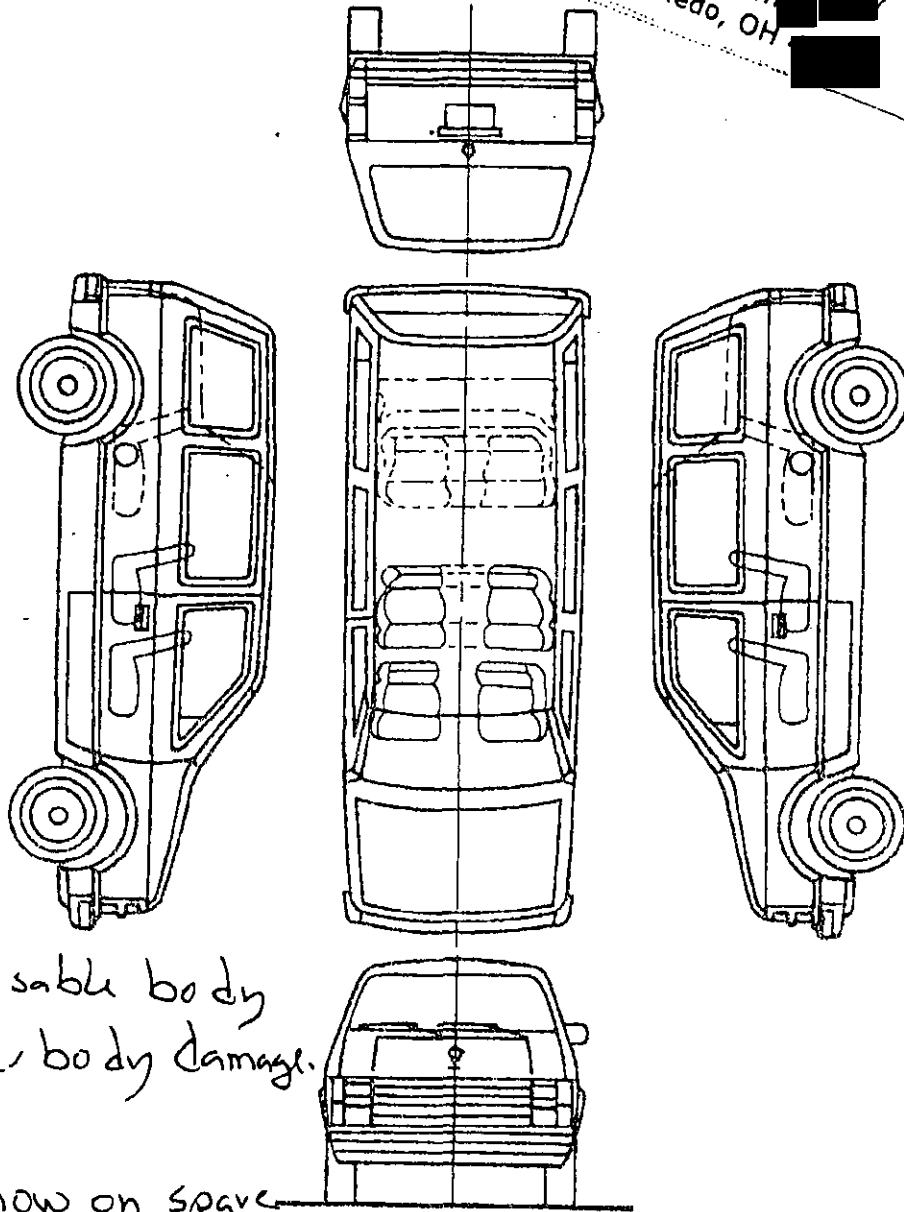

No visible body
 or under body damage.

RR Tire now on spare
 as there is a nail puncture
 mark in the tread. Nothing noted
 that should deploy the air bags

Sketch damage on all views. Include dimensions to describe and locate each damaged area and maximum depth of penetration for each impact. Annotate observations which might be useful in reconstructing the accident (e.g., direction of scrapes, markings on tires and wheels, etc.). Take photographs.

ED SCHMIDT

AUTOMOTIVE GROUP



ED SCHMIDT PONTIAC-GMC, INC.
26875 N. Dixie Hwy., PERRYSBURG, OH. 43551
(419) 874-4331



ED SCHMIDT FORD
9760 Waterville-Swanton Rd.
WATERVILLE, OH. 43566
(419) 878-8151

THE TRUCK STORE

ed schmidt



1270 CONANT ST. • MAUMEE, OHIO 43537 • PHONE (419) 872-4488

Please send all payments to: Ed Schmidt Pontiac-GMC, Inc. • 1280 Conant St. • Maumee, Ohio 43537
Visit us on the web at: www.edschmidt.com

CUSTOMER NO. 102236	ADVISOR DENNIS KINNEY	1581	TAG NO. 3052	INVOICE DATE 08/20/01	INVOICE # CHCS535056
TOLEDO, OH	LABOR RATE 69.00	LICENSE NO.	MILEAGE 2,078	CHASSIS BR SILVER/D	02 3154
	YEAR / MAKE / MODEL 02/JEEP/LIBERTY/LIBERTY 4WD SPORT			DELIVERY DATE 08/30/01	DELIVERY MILES 61
	VEHICLE ID NO. 1J4GL48K72W			SELLING DEALER NO.	08/08/01
	COMMENTS C# 06-14-01		E# NO MSO		

LABOR & PARTS
 # 1: 11CHZ GENERAL REPAIRS 1 HOUR \$11.00 TECH(S) 6094
 INSPECTION FOR AIR BAG DEPLOYMENT
 INSPECT FOR STORED AND EXISTING CODES
 AIR BAG CODES: ACTIVE 1.DRIVER SQUIB OPEN #1 2.PASS SQUIB OPEN #1 3.DRIVER SQUIB CIRCUIT OPEN #2 4.PASS SQUIB CIRCUIT OPEN #2 5.DRIVER SEAT BELT TENSIONER OPEN STORED CODE 1.DRIVER SQUIB #1 CIRCUIT OPEN #2 PASS SQUIB #1 CIRCUIT OPEN 3.DRIVER SQUIB #1 SHORT TO GROUND 4.DRIVER SQUIB #2 CIRCUIT OPEN 5.PASS SQUIB #2 CIRCUIT OPEN 6.DRIVER SQUIB #2 SHORT TO GROUND 7.DRIVER SEAT BELT TENSIONER OPEN

JOB # 1 TOTAL LABOR & PARTS 69.00

ESTIMATE
 CUSTOMER HEREBY ACKNOWLEDGES RECEIVING
 ORIGINAL ESTIMATE OF \$69.00 (+TAX)
 TOTALS

*** CASH () DISCOVER () CHECK # ()	TOTAL LABOR ... 69.00
* PAID	TOTAL PARTS ... 0.00
* AMERICAN EXPRESS () MASTERCARD/VISA ()	TOTAL SUBLET ... 0.00
* ACCTS RECEIVABLE ACCOUNT # ()	TOTAL G.O.G. ... 0.00
	TOTAL MISC CHG ... 0.00
	TOTAL MISC DISC ... 0.00
	TOTAL TAX ... 0.00
	TOTAL INVOICE \$ 69.00

THANK YOU FOR CHOOSING THE ED SCHMIDT AUTO GROUP FOR YOUR AUTOMOTIVE NEEDS!!!

Case 9027763
Vin # 1J4GL48K72W

Toledo, OH

00: 215201716994
 ED SCHMIDT PONTIAC GMC
 1280 CONANT ST
 MAUMEE, OH 43537

00: 44639
 TIME 11:31 AM DATE 08/20/01
 ACCT #
 EXP DATE 0502
 CARD TYPE MASTERCARD
 TRN TYPE SALE
 TERMINAL # 00831820
 AUTH CODE 379211
 RECORD # 002
 AMOUNT \$69.00

In the event that you, the customer, authorize commencement but do not authorize completion of a repair or service, a charge will be imposed for disassembly, reassembly or partially completed work. Such charge will be directly related to the actual amount of labor and parts involved in the inspection, repair or service.
DISCLAIMER OF WARRANTIES: Any warranties sold herein are those made by the manufacturer of those products. The seller, ED SCHMIDT PONTIAC GMC, INC., THE ED SCHMIDT TRUCK STORE and ED SCHMIDT FORD, L.L.C. hereby expressly disclaims all warranties, either express or implied, including any implied warranties of merchantability or fitness for a particular purpose regarding any products or services provided, unless otherwise indicated on the repair order. ED SCHMIDT PONTIAC GMC, INC., THE ED SCHMIDT TRUCK STORE, and ED SCHMIDT FORD, L.L.C., neither assumes nor authorizes any other person to assume for it any liability in connection with the sale of said products or services. This disclaimer by ED SCHMIDT PONTIAC GMC, INC., THE ED SCHMIDT TRUCK STORE, and ED SCHMIDT FORD, L.L.C. in no way affects the terms of performance of the manufacturer's warranty.
 This dealership utilizes the hours published in the manufacturer's labor/time guide which reflect an average time requirement for the performance of specific vehicle repairs, and which may, therefore, be either more or less than the actual clock time in any given instance.
 * SUPPLIES: A token charge equivalent to 1% of the labor charge to a maximum of \$25.00 is included for supplies used on your vehicle. Applicable supply items are: Nuts, bolts, washers, tape, pins, aerospray, shelec, solvent, rags, carburetor cleaner, towels, solder, battery cleaner, wire, window sealer, etc.

ARCHITECTURE
CAIR*

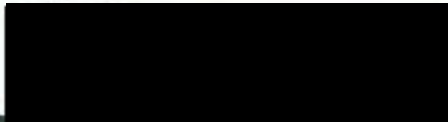

22:13



Jeep



NO
PARKING

9594

22:14



NO
PARKING

22:14



DAVE

NO
PARKING

8514

M

22:14

DAVE
MARSTON



22:15



Quick Lane

LIBERTY 4x4

4x4

4x4

22:15



22:15







22:16



Jeep

22:19



CALL FOR SERVICE
CALL FOR SERVICE
CALL FOR SERVICE
CALL FOR SERVICE
CALL FOR SERVICE
CALL FOR SERVICE
CALL FOR SERVICE
CALL FOR SERVICE
CALL FOR SERVICE
CALL FOR SERVICE

22 1:20

Jeep

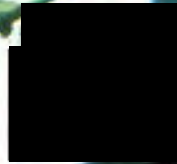

22128











22 1:30

December 13, 2002

ICC

Ms. Marcia Bailey Product Litigation 485-13-62

A. Gilbert Special Investigations 431-00-00

Reference: 1J4GL48K62W [REDACTED], CAIR # [REDACTED], Architecture North

Dear Ms. Bailey:

Please find enclosed attorney letter dated November 6, 2002 and our files on this matter. I am forwarding this to your office for review and handling due to the possible magnitude of this incident.

Sincerely,

A. L. Gilbert
Special Investigations
(248) 944-7037

Enclosure(s)

ALG/kat

*Please
imply 10174069*

Robert E Cousineau

07/01/02 12:45 PM

To: Arthur L Gilbert/FRC/DCC/DCX@wk-America
cc: Robin T Hartzell/CLTB/DCC/DCX@wk-America, David E
Friedel/CLTB/DCC/DCX@wk-America
Subject: 2002 Liberty Airbag Deployed

Mr. Gilbert,

The STAR Center received the following call about a 2002 Liberty in which the airbags deployed, but not in an accident situation. Please contact Paul Hanson at the dealer. Thanks for your assistance.

Bob Cousineau

Daimler Chrysler
S.T.A.R. Center
Body / Chassis / Electrical Group
Phone: T/L 722-7075
Outside: 248-512-7075
Fax: 248-512-7904
EMAIL: rec4@dcx.com
CIMS 429-08-05

*7-1-02
Request
Inspection*

10174069

DAW STAR Agency: 91873rc Version: 7.4.3 - [Case Update]

CASE UPDATE

Case No: [REDACTED] Date: [REDACTED] Time: [REDACTED]

Vehicle: [REDACTED] VIN: [REDACTED] Make: [REDACTED] Model: [REDACTED]

Year: [REDACTED] Color: [REDACTED] Mileage: [REDACTED] Status: [REDACTED]

Reported By: [REDACTED] Reported On: [REDACTED] Reported At: [REDACTED]

Investigator: [REDACTED] Assigned To: [REDACTED] Assigned On: [REDACTED]

Priority: [REDACTED] Status: [REDACTED] Category: [REDACTED] Sub-Category: [REDACTED]

Call Type: [REDACTED] Call Status: [REDACTED] Call Date: [REDACTED]

Call Time: [REDACTED] Call Duration: [REDACTED] Call Location: [REDACTED]

Call Description: [REDACTED]

Customer Complaint: [REDACTED]

Investigation Notes:

Report: Customer complaint - air bag light came on for about 15 seconds - then the driver side airbag deployed - there was a 5 second delay, then the pass side bag deployed. There were no reported injuries.
:CWO# 07/01/2002

Report: Advised tech not to do anything until special investigations contacts him. Contact Paul Hanson. Sent to T2 for further action.
:CWO# 07/01/2002

System: [REDACTED] Status: [REDACTED] Date: [REDACTED]

Print Refresh Close



28635 Mound Road
Warren, Michigan 48092-3499
(586) 753-3326
FAX (586) 753-3335

Facsimile Cover Sheet
DaimlerChrysler Vehicle Investigation

Owner: Architecture

Project No. DAIM-0001

CAIR No.: [REDACTED]

TO: Cal Compe

FROM: Tina Martin

Date Sent: 7-2-02

DUE DATE: 7-8-02

***PLEASE ACKNOWLEDGE PROMPTLY BY FAX OR EMAIL**

***Receipt of CAIR and Accepting case for investigation?** Yes No

Date: 07/02/02

Coversheet for DaimlerChrysler (Service Associate Use Only)
(Also fax or email to EAA for closure)

*Closure Date: 7-3-02

DaimlerChrysler Fax No.: 248- 512-8748

Bennis (248) 944-7036

Martell (248) 944-7038

Bott (248) 944-7056

Susalla (248) 944-7149

Gilbert (248) 944-7037

Porterfield (248) 944-7134

Comments: _____

107/01/02 CAIR Data File [redacted] txt CAIR: [redacted] 1/ 1 Page: 1
 Company: ARCHITECTURE NORTH L [redacted] Tmp Address:
 Cust: MR [redacted] UNKNOWN
 AD1: [redacted] Ph: [redacted] H
 AD2: [redacted] Ph: [redacted]
 Cty/St/ZIP: ARBOR VITAE WI [redacted] Cntry: USA Lang: E
 Co-own: [redacted]

Company:
 Rep:
 AD1: Ph:
 AD2: Ph:
 Cty/St/ZIP: Cntry: Lang:

Status and Notes	Check Information
Opened by: ALG2 Open Dt: 070102 Typ: L	Ck Amt: \$.00 S:
Stat: 0 Closed by: Closed Dt:	Payee:
Alrt: A Curresep: 82E 82	Addr1:
Lst Upd: 070102 1540P ALG2 82	Addr2:
Cntc Typ: T Orig: C Mail Ctgr: Y	City:
Dt on Ltr: Exec:	St/ZIP:
Resp Ltr: Resp Ltr Dt:	

Vehicle Information -----
 VIN: 1J4GL48K62W [redacted] YR/Model: 02 JEEP LIBERTY SPORT 4X4 SPORT UTILITY 4-DR
 Sls Zn/Sls/Svc/Dlr: 55 F F 43956 DAVE MARSTON MOTORS IN In Srv Date: 04/30/02
 Svc Zn/Sls/Svc/Dlr: 55 F F 43956 DAVE MARSTON MOTORS IN Curr Mi/Km: M 3900
 WCC: 336 - /36 3/36 0 7
 CSC: HHW7100J - 7/100,000 EXTEND LTD PTWN WARR

General Narrative -----
 REASONS FOR CONTACT:
 1) Air Bag Inquiry - Both Air Bags deployed

*--> NARRATIVE ADDED BY A. L. GILBERT ON 07/01/02 AT 03:43PM
 7-1-02 e mail from S.T.A.R. center.
 owner alleges air bag light came on for 15 seconds and then drivers
 side air bag deployed then after 5 seconds passenger side deployed.
 no accident.
 location:
 43956 DAVE MARSTON MOTORS INC CJDY
 9594 HWY 70 WEST MINOCQUA WI 54548 715-356-3242
 contact: paul hanson
 7-1-02 please contact dealer and owner if possible and arrange for
 inspection on deployment of air bags. need drb codes and times.
 check for hidden/prior damage. thanks. art gilbert
 CAIR NUMBER [redacted] REQUEST EAA INSPECTION 07-01-2002 15:45

DAIMLERCHRYSLER

Confidential Preliminary Vehicle Investigation Report

REF # 101746

YEAR 02	MODEL JEEP SPT 4x4	LIBERTY	VEHICLE IDENTIFICATION NUMBER 1J4BL48K62W1	ODOMETER 14838	M.D.H. 04/23/9	DELIVERY DATE 04/30/02
NAME OF OWNER		ADDRESS/LOCATION				
CITY ARBOR VITAE		STATE WI	ZIP	BUSINESS PHONE	HOME PHONE	
SELLING DEALER NAME DAVE MARSTON Motors, Inc		ZONE 55	DLR. CODE 43956	CITY MINOCQUA	STATE WI	
CHRYSLER REPRESENTATIVE - PRINT CAL COMPE		ZONE 55	PHONE 920-897-3201	<input type="checkbox"/> MINOR <input checked="" type="checkbox"/> MODERATE <input type="checkbox"/> MAJOR		REPAIR ESTIMATE \$ No estimate
INTERVIEW						
INTERVIEW DATE		DATE OF INCIDENT 06/27/02	TIME OF INCIDENT 11:35 AM	INSPECTION DATE 07/03/02		
<input type="checkbox"/> DRIVER <input type="checkbox"/> OWNE <input type="checkbox"/> OTHE <input type="checkbox"/> DESCRIP						
DRIVER STATED he Southbound on Int 94 About 10 miles North of MADISON, WI TRAVELING 65MPH. HE WAS DRIVING IN STOP & GO TRAFFIC FOR ABOUT 15-20 MINUTES AND JUST WHEN HE GOT OUT OF IT & GOT UP TO SPEED AN ALARM WENT OFF. HE LOOKED AT THE DASH & SAW THE "AIRBAG" LAMP ON.						
<input type="checkbox"/> Driver's and/or occupant's description of incident <input type="checkbox"/> What? When? Where? How? <input type="checkbox"/> Exact order of events <input type="checkbox"/> Did this happen before?						
Personal Injury: Were there Personal Injuries? <input type="checkbox"/> Yes <input checked="" type="checkbox"/> No If yes, complete section "L." (CONT)						

IMPORTANT: SHOW TO NO ONE & DRAW NO CONCLUSIONS

- DIRECTIONS:
- FILL OUT UPPER PART OF FORM.
 - FOR "FIRE" USE FORM 84-130-6950.
 - FOLLOW INSTRUCTIONS FOR SECTION "A" ON ALL VEHICLES.
 - FOLLOW INSTRUCTIONS FOR SPECIFIC ALLEGATIONS FOR THIS VEHICLE.
 - ATTACH ANY ADDENDUMS TO REPORT AND STATE SECTION IT PERTAINS TO.

- COMMENTS:
- NOTE ANY MISSING COMPONENTS AND WHO REMOVED THEM.
 - NOTE ANY AFTERMARKET EQUIPMENT INSTALLED AND BY WHOM.

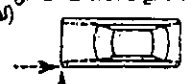
ALLEG.	PHOTOGRAPH REQUIRED	INFORMATION	EVALUATION
A General	<input checked="" type="checkbox"/> From center of vehicle front every 45 degrees (8 total) <input type="checkbox"/> If crash damaged — perspective from every corner of vehicle down both original lateral sight lines. (8 total) 	<input checked="" type="checkbox"/> Police report NONE <input checked="" type="checkbox"/> Vehicle service file NONE <input type="checkbox"/> Any reports/photos by others NO <input type="checkbox"/> Location of inspection	<input type="checkbox"/> Driver's and/or occupant's description of incident <input type="checkbox"/> Complete exterior damage diagram and measurements on last page. <input type="checkbox"/> What? When? Where? How? <input type="checkbox"/> Exact order of events <input type="checkbox"/> Did this happen before?
B Airbag(s)	<input type="checkbox"/> Steering Wheel <input checked="" type="checkbox"/> Airbag(s) <input type="checkbox"/> Knee Blockers <input checked="" type="checkbox"/> All possible body contact areas <input type="checkbox"/> All code readings using DRB II	<input type="checkbox"/> Record: <input checked="" type="checkbox"/> Was Airbag deployed? Driver <input checked="" type="checkbox"/> Yes <input type="checkbox"/> No Passenger <input checked="" type="checkbox"/> Yes <input type="checkbox"/> No <input type="checkbox"/> Type of Steering Wheel <input checked="" type="checkbox"/> Tilt <input type="checkbox"/> Std. <input type="checkbox"/> Condition of Steering Wheel <u>STRAIGHT</u> <input type="checkbox"/> Condition of Steering Wheel Mounting (measure column collapse) <u>NO DAMAGE</u>	<input type="checkbox"/> Evidence of tampering or disassembly? <input type="checkbox"/> Yes <input checked="" type="checkbox"/> No <input type="checkbox"/> Use DRB II <input checked="" type="checkbox"/> Record Existing Readings 1 _____ 2 _____ <input type="checkbox"/> Record Stored Readings 1 _____ 2 _____ 3 _____ <input checked="" type="checkbox"/> Important: DO NOT ERASE DRB II READINGS. AIRBAG LAMP COMES ON WITH IGNITION & STAYS ON

Confidential

REF. # 10174067

ALLEG.	PHOTOGRAPH REQUIRED	INFORMATION	EVALUATION																								
H Seat/Shoulder Belts	<input type="checkbox"/> Overall of seat belts I/B and O/B. <input type="checkbox"/> Close ups of any irregularities on belts. <input type="checkbox"/> Shoulder Belt Pendulum <input type="checkbox"/> Latchplate wear <input type="checkbox"/> Close up of D-ring to show belt loading.	<input type="checkbox"/> Locate seat belt labels and record ALL information (Some labels are sewn to webbing, other labels are on retractor frame. Inboard seat belt labels are near floor.) <u>BELT-LEFT-03102R</u> <u>TENSIONER IS DISABLED</u> <input type="checkbox"/> Record ALL information stamped on latchplate.	If allowed, function belts to insure they FUNCTION PROPERLY, note results: Do they latch? <input checked="" type="checkbox"/> Yes <input type="checkbox"/> No Do they release? <input checked="" type="checkbox"/> Yes <input type="checkbox"/> No Do they retract? <input type="checkbox"/> Yes <input checked="" type="checkbox"/> No <input type="checkbox"/> Does Inertia Pendulum System run freely? <input type="checkbox"/> Yes <input type="checkbox"/> No																								
I Seat	<input type="checkbox"/> Overall of seat <input type="checkbox"/> Close ups of damage <u>NA</u>	<input type="checkbox"/> Existing location of recliner - number of teeth from rear of sector gear to rear edge of Pawl (crayon mark location). <input type="checkbox"/> Existing location of seat adjuster (window or tooth location from rear of adjuster). <input type="checkbox"/> Existing location of head restraint (measure gap under head restraint).	<input type="checkbox"/> If allowed, adjust all functions of seat and return to original location <input type="checkbox"/> Describe functions <input type="checkbox"/> Note any irregular orientations																								
J Tires	<input type="checkbox"/> Each Tire with visible location label, insuring all Tire identification and Tread wear is documented. <input type="checkbox"/> All damaged Wheel and Rim area including impacted foreign material. <u>NA</u>	Record: <input type="checkbox"/> Tire Size <input type="checkbox"/> Brand <input type="checkbox"/> Ratings <input type="checkbox"/> DOT No. (I/B Side) <input type="checkbox"/> Rim Size <input type="checkbox"/> Tread Depth	<table border="1"> <thead> <tr> <th>Front Left</th> <th>Front Right</th> <th>Rear Left</th> <th>Rear Right</th> </tr> </thead> <tbody> <tr><td> </td><td> </td><td> </td><td> </td></tr> <tr><td> </td><td> </td><td> </td><td> </td></tr> <tr><td> </td><td> </td><td> </td><td> </td></tr> <tr><td> </td><td> </td><td> </td><td> </td></tr> <tr><td> </td><td> </td><td> </td><td> </td></tr> </tbody> </table>	Front Left	Front Right	Rear Left	Rear Right																				
Front Left	Front Right	Rear Left	Rear Right																								
K Axle Lockup	<input type="checkbox"/> Entire Axle and close up of Leaks <u>NA</u>	<input type="checkbox"/> While on hoist: <input type="checkbox"/> Rear Wheel Drive Record amount of Lateral Axle Movement on each side and will Wheels turn <input type="checkbox"/> Trans. Axle - rotate Wheels <input type="checkbox"/> Note function																									
L Occupant Contact	<input type="checkbox"/> Windshield <input type="checkbox"/> All areas of occupant contact on interior and exterior. <input type="checkbox"/> Close ups of stains, skin, hair, cloth <input type="checkbox"/> Exterior and interior damage	<input type="checkbox"/> See Seat Belt/Seats if applicable <input type="checkbox"/> Occupant contact description <u>NO EVIDENCE of occupant contact</u>																									

ADDITIONAL COMMENTS

7-2-02 Vehicle inspect - NO EVIDENCE OF ANY IMPACT ON VEHICLE ANYWHERE, INCLUDING UNDERCARRIAGE - WE WERE UNABLE TO OBTAIN A DRB READING - CALLED TECH CENTER - SPOKE TO PAT. HE SAID TO TRY THE DRB ON ANOTHER JEEP LIBERTY TO SEE IF IT WORKS AND IF IT DOES THEN THE REASON WE CAN'T GET A READING IS BECAUSE THE MODULE IS BAD OR BURNED UP. HE SAID TO TELL THE DEALER TO GO AHEAD & REPAIR VEHICLE. I TOLD SER MGR & ALSO TOLD HIM TO KEEP DEFECTIVE PARTS THIS INCIDENT ALSO CAUSED SEATBELT TENSIONER TO FAIL.

Description of Event (cont)

He said he quickly got the owners manual out and opened it across the steering wheel - He smelled an odor like electrical wires burning and then the driver airbag deployed. In just seconds the passenger bag deployed. He was able to control the vehicle without hitting anyone or anything. He drove to the Jeep dealer in Madison WI and asked if they could check to determine what caused the bags to deploy and if it was OK to drive. They told him they didn't think there was anything they could do & it was OK to drive and he should go back to where he bought it. So, he said he cut the bags off and returned the car to the selling dealer. He stated prior to the incident there wasn't anything wrong with the driveability or anything else unusual.

Confidential

REF. #10174068

ALLEG.	PHOTOGRAPH REQUIRED	INFORMATION	EVALUATION
C	Sudden Acceleration or Throttle Hold <input type="checkbox"/> Accelerator Pedal <input type="checkbox"/> Throttle Cable <input type="checkbox"/> Return Springs <input type="checkbox"/> Floor Mats	<input type="checkbox"/> Describe any Accelerator Pedal interference with Carpet/Mat _____ _____ _____ _____	<input type="checkbox"/> DRB II Tests <input type="checkbox"/> Disconnect Cable at Throttle Body/Carburetor lever; operate: <input type="checkbox"/> Lever <input type="checkbox"/> Cable <input type="checkbox"/> Any restricted motion? <input type="checkbox"/> Yes <input type="checkbox"/> No <input type="checkbox"/> If safe and permitted to drive - attempt to duplicate and check Service Brakes at reported speed.

D	Brakes <input type="checkbox"/> Items in Information Block.	<input type="checkbox"/> Check and record Brake Fluid Level. _____ <input type="checkbox"/> Check and record if Vacuum Hose is connected. <input type="checkbox"/> Yes <input type="checkbox"/> No <input type="checkbox"/> Check and record for Brake Line Leaks. <input type="checkbox"/> Yes <input type="checkbox"/> No <input type="checkbox"/> Pull Wheels, check Linings and record condition. <input type="checkbox"/> Check Brake Pedal, does it set firm? <input type="checkbox"/> Yes <input type="checkbox"/> No <input type="checkbox"/> Check operation of Parking Brake. <input type="checkbox"/> Check operation of ABS System.	With Engine off: <input type="checkbox"/> Apply Brake fully 3 or 4 times. <input type="checkbox"/> With light force held to Pedal, start the Engine. <input type="checkbox"/> Note reaction of Pedal and record: _____ _____ <input type="checkbox"/> ABS System DRB II test readouts _____ _____
----------	--	---	---

E	Steering <input type="checkbox"/> Complete Steering System Including as required: • Rack & Pinion • Linkage • CV & Universal Joints • Column • Belts & Pulleys	<input type="checkbox"/> Record if: <input type="checkbox"/> Manual Steering <input type="checkbox"/> Power Steering <input type="checkbox"/> Check Fluid Level _____ <input type="checkbox"/> Record if Drive Belt is tight <input type="checkbox"/> Yes <input type="checkbox"/> No <input type="checkbox"/> Check for Hose/System leaks <input type="checkbox"/> Yes <input type="checkbox"/> No Leaks <input type="checkbox"/> Check condition of Steering Linkage from Wheels to Steering Column, record deformation or loose connections. _____ _____	<input type="checkbox"/> Unlock key and turn Wheels fully right and left. <input type="checkbox"/> If safe, start Engine and turn Wheels fully right and left. <input type="checkbox"/> Record Steering function.
----------	--	--	---

F	Transmission <input type="checkbox"/> Entire Transmission with pictures and closeup of leaks, if any.	<input type="checkbox"/> Record: Type of Transmission? <input type="checkbox"/> Auto <input type="checkbox"/> Std. How many Speeds? <input type="checkbox"/> 3 <input type="checkbox"/> 4 <input type="checkbox"/> 5 <input type="checkbox"/> Record Gear Shift location at time of inspection _____ _____ <input type="checkbox"/> Run Shift Lever thru all shift positions and record "Feel of Gating" _____ _____ <input type="checkbox"/> Is Shift Indicator properly aligned? <input type="checkbox"/> Yes <input type="checkbox"/> No	If safe and permitted to drive vehicle: <input type="checkbox"/> Drive Vehicle and record feel of Gear during each Gear Shift. _____ _____ _____ <input type="checkbox"/> Does Parking Pawl engage? <input type="checkbox"/> Yes <input type="checkbox"/> No <input type="checkbox"/> If lockup is alleged - check rotation of Transmission in all Gears. <input type="checkbox"/> Check starting ability in park and neutral. Check to see that start does not occur in other selector positions.
----------	--	---	--

G	Engine Stall/ Drivability <input type="checkbox"/> Complete Engine Compartment Including as required: • Underhood Emissions Label • Engine Wiring/Connections • Vacuum Hoses • Fuel Lines • Exhaust System • Spark Plugs • Connections	<input type="checkbox"/> Record type of Spark Plugs (location of unique plugs). _____ _____ _____ _____ _____	If safe and permitted to: <input type="checkbox"/> Try to duplicate Allegation Off Hiway <input type="checkbox"/> DRB II or I/P Fault Code Test _____ _____ _____
----------	--	--	--

Confidential

REF. # 1017406

Exterior Damage Diagram and Measurements

No DAMAGE

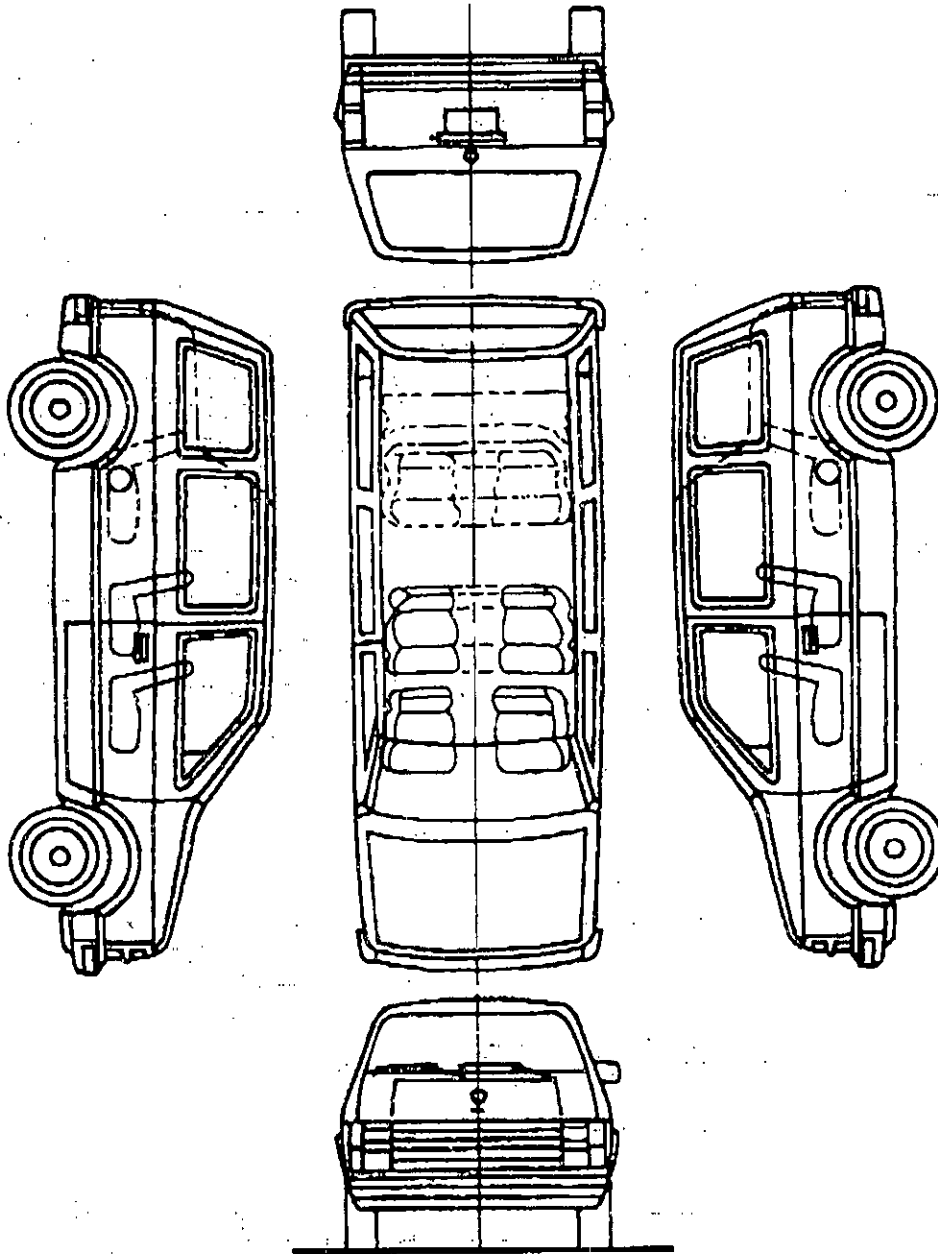

Sketch damage on all views. Include dimensions to describe and locate each damaged area and maximum depth of penetration for each impact. Annotate observations which might be useful in reconstructing the accident (e.g., direction of scrapes, markings on tires and wheels, etc.). Take photographs.

Yahoo! Mail - banjobud3@yahoo.com

Page 1 of 2

28638 Mot

Warren, Michigan 48

(588)

FAX (588):

Facsimile Cover Sheet

DaimlerChrysler Vehicle Investigation

Owner:



Project No. DAIM-0001 CAIR No.:

TO: Bud Nelson

FROM: Tina Martin

Date Sent: 9-17-02

DUE DATE: 9-20-02

FAX
8 PAGES TOTAL

***PLEASE ACKNOWLEDGE PROMPTLY BY FAX OR EMAIL**

***Receipt of CAIR and Accepting case for investigation**
No

Date:

.../ShowLetter?box=Inbox&MsgId=7234_129986_3110_1083_28146_0_22933&bodyPa9/17/02

Yahoo! Mail - banjobud3@yahoo.com

Page 2 of 2

Coversheet for DaimlerChrysler (Service Associate Use Only)

(Also fax or email to EAA for closure)

***Closure Date: DaimlerChrysler Fax No.: 248- 512-8**

Bennis (248) 944-7036 Martell (248) 944-7038

Bott (248) 944-7056 Susalla (248) 944-7149

Arch **Gilbert (248) 944-7037 Porterfield (248) 944-7134**

Comments:

.../ShowLetter?box=Inbox&MsgId=7234_129986_3110_1083_26146_0_229338&bodyPa9/17/02

Yahoo! Mail

File name: 10447704.txt

File type: application/octet-stream

1001702 CAIR Data File CAIR: 05 1/1 Page: 1

Company: Tmp Address:

Cust:

AD1:

AD2: Ph:

Cty/ST/ZIP: LARGO FL Cntry: USA Lang: E

Co-addr:

Company:

Rep:

AD1: Ph:

AD2: Ph:

Cty/ST/ZIP: Cntry: Lang:

Status and Notes -----|Check Information|-----

Opened by: RCH8 Open Dt: 001702 Typ: L | Ck Amt: \$.00 E:

Stat: O Closed by: Closed Dt: | Payee:

Akt: A Cur/rep: ALG2 82 |

Let Upd: 001702 1020A ALG2 82 | Addr1:

Cntr Typ: T Orig: C Mail Orig: | Addr2:

Dt on Ltr: Exec: | City:

Resp Ltr: Resp Ltr Dt: | ST/ZIP:

Vehicle Information -----

VIN: 1J8GK58K02V YR/Model: 02 JEEP LIBERTY LTD EDITION 4X2 SPORT UTILIT

Bus Zn/Biz Svc/Dir: 88 K K 82821 DAYTON ANDREWS INC In Srv Date: 11/16/01

Svc Zn/Biz Svc/Dir: 88 K K 82821 DAYTON ANDREWS INC Curr MIA/Km: M 8325

WCC: 338 - /38 3/38 8 7

.../ShowLetter?box=Inbox&MsgId=

&bodyPa9/17/02

Yahoo! Mail - [REDACTED]

CSC: HNRAT70P- 7/79 WARRANTY WRAPAROUND

Recall: A07 - AIR BAG WIRE CHAFING SAFETY Status: I

General Narrative

REASONS FOR CONTACT:

1) Air Bag Inquiry

*-> NARRATIVE ADDED BY [REDACTED] ON 09/17/02 AT 09:18AM

9/17/02 RCH6 owner was driving down the road and air bag light came on and air bag deployed without any impact. Owner has been put in a rental car and vehicle is at [REDACTED] Charlie Flatley, Service Manager, has keys and knows of vehicle. Dealer phone 727-769-4439. Owner and DM request EAA inspection.

Please advise DM, Bob Horn 407-748-8787

NOTE: Recall A07 air bag wiring chafing has not been performed.

*-> NARRATIVE ADDED BY A. L. GILBERT ON 09/17/02 AT 10:21AM

62821 DAYTON ANDREWS INC CJ

2388 GULF TO BAY BOULEVA CLEARWATER FL 33765 727-769-4439

9-17-02 please contact owner and arrange for inspection on deployment of air bags. need d/e codes and times. check for hidden damage. Thanks.

art gilbert

CAR NUMBER [REDACTED] REQUEST EAA INSPECTION 09-17-2002 10:22

*mon - 9/16/02
7 AM?*

*no. clear.
Just turned corner 30-35 MPH.
Light f. help
came on - then both deployed.
Driver's head is
stomach bruised -*

.../ShowLetter?box=Inbox&MsgId=[REDACTED]&bodyPa9/17/02

DAIMLERCHRYSLER

Confidential Preliminary Vehicle Investigation Report

REF. # 10447294

YEAR 2002	MODEL JEEP	VEHICLE IDENTIFICATION NUMBER 1J06K59M62W	SECURITY NUMBER 8325	M.I.H. 101023	DELIVERY DATE 11-6-01
NAME OF OWNER		ADDRESS			
CITY LARGO	STATE FL	ZIP	BUSINESS PHONE	HOME PHONE	
SELLING DEALER NAME DAYTON ANDREAS		ZONE 66	DLR CODE 62621	CITY CLEARWATER	STATE FL
SALES REPRESENTATIVE C.L. (BUD) NELSON		PHONE 494-9517	ORIG. OWNER		REPAIR ESTIMATE MINOR MODERATE MAJOR

INTERVIEW

INTERVIEW TYPE <input type="checkbox"/> DRIVER <input type="checkbox"/> OWNER <input type="checkbox"/> OTHER	INTERVIEW DATE 09/18/02	DATE OF INCIDENT 09/16/02	TIME OF INCIDENT 7: AM	INSPECTION DATE 09/18/02
---	----------------------------	------------------------------	---------------------------	-----------------------------

DESCRIPTION OF EVENT (INCLUDING WEATHER CONDITIONS AND ROAD SURFACE)
CLEAR

Driver's and/or occupant's description of incident
 What? When? Where? How?
 Exact order of events
 Did this happen before?

JUST TURNED CORNER, AT 35MPH, AIRBAG LIGHT CAME ON, BELL DINGED AND ONE MINUTE LATER BOTH AIRBAGS DEPLOYED. PASS. HIT IN JAW BY DEBRIS, DRIVER'S STOMACH BRUISED BY BAG.

Personal Injury: Were there Personal Injuries? Yes No If yes, complete section "L."

IMPORTANT: SHOW TO NO ONE & DRAW NO CONCLUSIONS

- DIRECTIONS:**
- FILL OUT UPPER PART OF FORM.
 - FOR "FIRE" USE FORM 84-130-8950.
 - FOLLOW INSTRUCTIONS FOR SECTION "A" ON ALL VEHICLES.
 - FOLLOW INSTRUCTIONS FOR SPECIFIC ALLEGATIONS FOR THIS VEHICLE.
 - ATTACH ANY ADDENDUMS TO REPORT AND STATE SECTION IT PERTAINS TO.

- COMMENTS:**
- NOTE ANY MISSING COMPONENTS AND WHO REMOVED THEM.
 - NOTE ANY AFTERMARKET EQUIPMENT INSTALLED AND BY WHOM.

ALLEG.	PHOTOGRAPH REQUIRED	INFORMATION	EVALUATION
A	<input type="checkbox"/> Front center of vehicle front every 45 degrees (8 total) <input type="checkbox"/> If crush damaged - perspective from every corner of vehicle down both original lateral sight lines (8 total)	<input type="checkbox"/> Police report <input type="checkbox"/> Vehicle service file <input type="checkbox"/> Any reports/photos by others <input type="checkbox"/> Location of inspection	<input type="checkbox"/> Driver's and/or occupant's description of incident <input type="checkbox"/> Complete exterior damage diagram and measurements on last page. <input type="checkbox"/> What? When? Where? How? <input type="checkbox"/> Exact order of events <input type="checkbox"/> Did this happen before?

B	<input checked="" type="checkbox"/> Steering Wheel <input checked="" type="checkbox"/> Airbag(s) <input type="checkbox"/> Knee Blockers <input type="checkbox"/> All visible body contact areas <input checked="" type="checkbox"/> All code readings using DRB II	<input checked="" type="checkbox"/> Record: <input type="checkbox"/> Was Airbag deployed? Driver <input checked="" type="checkbox"/> Yes <input type="checkbox"/> No Passenger <input type="checkbox"/> Yes <input type="checkbox"/> No <input type="checkbox"/> Type of Steering Wheel <input checked="" type="checkbox"/> TIR <input type="checkbox"/> Std. <input type="checkbox"/> Condition of Steering Wheel UNDAMAGED <input type="checkbox"/> Condition of Steering Wheel Mounting (measure column collapse) UNDAMAGED	<input type="checkbox"/> Evidence of tampering or disassembly? <input type="checkbox"/> Yes <input checked="" type="checkbox"/> No <input type="checkbox"/> Use DRB II <input type="checkbox"/> Record Existing Readings 1. NO READINGS - COULD NOT ACCESS AIRBAG CODES - ENGINE 2. ALL OTHERS CAN BE READ BUT NOTHING ON AIRBAGS. <input type="checkbox"/> Record Stored Readings 1. _____ 2. _____ 3. _____ <input type="checkbox"/> Important: DO NOT ERASE DRB II READINGS.
----------	--	---	---

Confidential

REF. #

ALLEG.	PHOTOGRAPH REQUIRED	INFORMATION	EVALUATION
Sudden Acceleration or Throttle Hold	<input type="checkbox"/> Accelerator Pedal <input type="checkbox"/> Throttle Cable <input type="checkbox"/> Return Springs <input type="checkbox"/> Floor Mats	<input type="checkbox"/> Describe any Accelerator Pedal Interference with Carpet/Mat <hr/> <hr/> <hr/> <hr/> <hr/> <hr/>	<input type="checkbox"/> DRB II Tests <input type="checkbox"/> Disconnect Cable at Throttle Body/Carburetor lever; operate: <input type="checkbox"/> Lever <input type="checkbox"/> Cable <input type="checkbox"/> Any restricted motion? <input type="checkbox"/> Yes <input type="checkbox"/> No <input type="checkbox"/> If safe and permitted to drive - attempt to duplicate and check Service Brakes at reported speed.
Brakes	<input type="checkbox"/> Items in Information Block.	<input type="checkbox"/> Check and record Brake Fluid Level. _____ <input type="checkbox"/> Check and record if Vacuum Hose is connected. <input type="checkbox"/> Yes <input type="checkbox"/> No <input type="checkbox"/> Check and record for Brake Line Leaks. <input type="checkbox"/> Yes <input type="checkbox"/> No <input type="checkbox"/> Pull Wheels, check Linings and record condition. <hr/> <input type="checkbox"/> Check Brake Pedal, does it set firm? <input type="checkbox"/> Yes <input type="checkbox"/> No <input type="checkbox"/> Check operation of Parking Brake. <input type="checkbox"/> Check operation of ABS System.	With Engine off: <input type="checkbox"/> Apply Brake fully 3 or 4 times. <input type="checkbox"/> With light force held to Pedal, start the Engine. <input type="checkbox"/> Note reaction of Pedal and record: <hr/> <hr/> <input type="checkbox"/> ABS System DRB II test readouts <hr/> <hr/>
Steering	<input type="checkbox"/> Complete Steering System including as required: • Rack & Pinion • Linkage • CV & Universal Joints • Column • Bells & Pulleys	<input type="checkbox"/> Record it: <input type="checkbox"/> Manual Steering <input type="checkbox"/> Power Steering <input type="checkbox"/> Check Fluid Level _____ <input type="checkbox"/> Record if Drive Belt is tight <input type="checkbox"/> Yes <input type="checkbox"/> No <input type="checkbox"/> Check for Hose/System leaks <input type="checkbox"/> Yes <input type="checkbox"/> No Leaks <input type="checkbox"/> Check condition of Steering Linkage from Wheels to Steering Column, record deformation or loose connections. <hr/> <hr/> <hr/>	<input type="checkbox"/> Unlock key and turn Wheels fully right and left. <input type="checkbox"/> If safe, start Engine and turn Wheels fully right and left. <input type="checkbox"/> Record Steering function.
Transmission	<input type="checkbox"/> Entire Transmission with pictures and closeup of leaks, if any.	<input type="checkbox"/> Record: Type of Transmission? <input type="checkbox"/> Auto <input type="checkbox"/> Std. How many Speeds? <input type="checkbox"/> 3 <input type="checkbox"/> 4 <input type="checkbox"/> 5 <input type="checkbox"/> Record Gear Shift location at time of inspection <hr/> <hr/> <input type="checkbox"/> Run Shift Lever thru all shift positions and record "Feel of Gating" <hr/> <hr/> <input type="checkbox"/> Is Shift Indicator properly aligned? <input type="checkbox"/> Yes <input type="checkbox"/> No	If safe and permitted to drive vehicle: <input type="checkbox"/> Drive Vehicle and record feet of Gear during each Gear Shift <hr/> <hr/> <hr/> <hr/> <input type="checkbox"/> Does Parking Pawl engage? <input type="checkbox"/> Yes <input type="checkbox"/> No <input type="checkbox"/> If lockup is alleged - check rotation of Transmission in all Gears. <input type="checkbox"/> Check starting ability in park and neutral. Check to see that start does not occur in other selector positions.
Engine Stall/ Drivability	<input type="checkbox"/> Complete Engine Compartment including as required: • Underhood Emissions Label • Engine Wiring/Connections • Vacuum Hoses • Fuel Lines • Exhaust System • Spark Plugs • Connectors	<input type="checkbox"/> Record type of Spark Plugs (location of unique plugs). <hr/> <hr/> <hr/> <hr/> <hr/> <hr/>	If safe and permitted to: <input type="checkbox"/> Try to duplicate Allegation Off Highway <input type="checkbox"/> DRB II or I/P Fault Code Test <hr/> <hr/> <hr/> <hr/>

Confidential

REF. [REDACTED]

ALLEG.	PHOTOGRAPH REQUIRED	INFORMATION	EVALUATION
H Seat/Shoulder Belts	<input type="checkbox"/> Overall of seat belts I/B and O/B. <input type="checkbox"/> Close ups of any irregularities on belts. <input type="checkbox"/> Shoulder Belt Pendulum <input type="checkbox"/> Latchplate wear <input type="checkbox"/> Close up of D-ring to show belt loading.	<input type="checkbox"/> Locate seat belt labels and record ALL information (Some labels are sewn to webbing, other labels are on retractor frame. Inboard seat belt labels are near floor.) <hr/> <input type="checkbox"/> Record ALL information stamped on latchplate. <hr/>	If allowed, function belts to insure they FUNCTION PROPERLY, note results: Do they latch? <input type="checkbox"/> Yes <input type="checkbox"/> No Do they release? <input type="checkbox"/> Yes <input type="checkbox"/> No Do they retract? <input type="checkbox"/> Yes <input type="checkbox"/> No <input type="checkbox"/> Does Inertia Pendulum System run freely? <input type="checkbox"/> Yes <input type="checkbox"/> No

I Seat	<input type="checkbox"/> Overall of seat <input type="checkbox"/> Close ups of damage	<input type="checkbox"/> Existing location of recliner - number of teeth from rear of sector gear to rear edge of Pawl (crayon mark location). <hr/> <input type="checkbox"/> Existing location of seat adjuster (window or tooth location from rear of adjuster). <hr/> <input type="checkbox"/> Existing location of head restraint (measure gap under head restraint). <hr/>	<input type="checkbox"/> If allowed, adjust all functions of seat and return to original location <input type="checkbox"/> Describe functions <hr/> <input type="checkbox"/> Note any irregular orientations. <hr/>
------------------	--	--	--

J Tires	<input type="checkbox"/> Each Tire with visible location label, insuring all Tire Identification and Tread wear is documented. <input type="checkbox"/> All damaged Wheel and Rim area including impacted foreign material.	Record: <input type="checkbox"/> Tire Size <input type="checkbox"/> Brand <input type="checkbox"/> Ratings <input type="checkbox"/> DOT No. (I/B Side) <input type="checkbox"/> Rim Size <input type="checkbox"/> Tread Depth	Front Left	Front Right	Rear Left	Rear Right

K Axle Lookup	<input type="checkbox"/> Entire Axle and close up of Leaks	While on hoist: <input type="checkbox"/> Rear Wheel Drive Record amount of Lateral Axle Movement on each side and will Wheels turn <hr/> <input type="checkbox"/> Trans. Axle - rotate Wheels <input type="checkbox"/> Note function <hr/>
-------------------------	--	---

L Occupant Contact	<input type="checkbox"/> Windshield <input type="checkbox"/> All areas of occupant contact on interior and exterior. <input type="checkbox"/> Close ups of stains, skin, hair, cloth <input type="checkbox"/> Exterior and Interior damage	<input type="checkbox"/> See Seat Belts/Seats if applicable <input type="checkbox"/> Occupant contact description <hr/> <hr/>
------------------------------	---	---

ADDITIONAL COMMENTS

THE SCANNER MESSAGE REGARDING AIRBAGS SAYS TO THE EFFECT, "SOFTWARE NOT CORRECT TO SECURE THE INFO. DESIRED."

Confidential

REF. [REDACTED]

Exterior Damage Diagram and Measurements

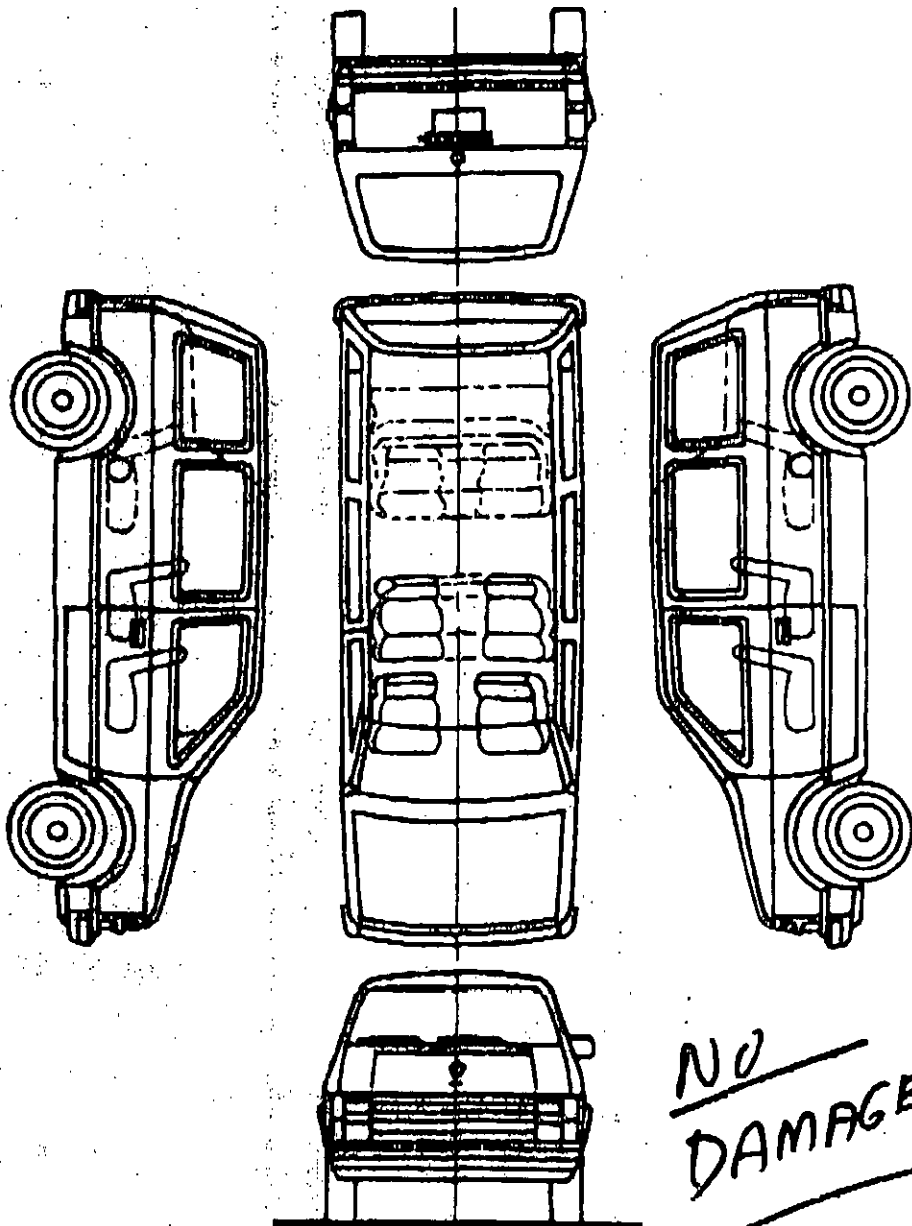

NO
DAMAGE

Sketch damage on all views. Include dimensions to describe and locate each damaged area and maximum depth of penetration for each impact. Annotate observations which might be useful in reconstructing the accident (e.g., direction of scrapes, markings on tires and wheels, etc.). Take photographs.

CHRYSLER MOTORS COMPANY LLC CUSTOMER CENTER

Customer

Address

(Street)

(City)

(State)

(Zip)

Daytime Telephone

VIN Number 1J4BL58K12W (2002 Liberty)

Date of Purchase 08-28-02 Mileage 2100

Servicing Dealer Adrian Dodge, Adrian, MI.

Number of days vehicle has been Out-of-Service 4

Number of repair attempts to repair same condition 4-Airbag 3-Pull

Description of Concern: Airbag light & pulls right

[Redacted]

Street Address

Lambertville MI [Redacted]

City, State, ZIP

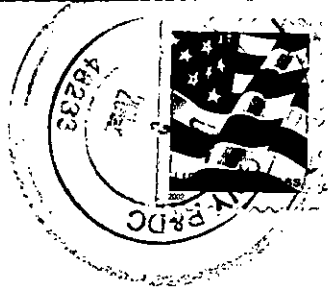

RECEIVED

OCT 08 2002

OWNER RELATIONS

DaimlerChrysler Motors Company LLC
Customer Center
P.O. Box 21-8004
Auburn Hills, MI 483 21-8004

10-05-02



01/21/2003

CONTROLLED ITEM F1001001



WARNING: DO NOT RE-SCREW BATTERY SCREWING
IMPROPER SCREWING CAN RESULT IN AIR BAG SYSTEM
FAILURE AND POSSIBLE DEATH AND/OR PERSONAL INJURY

CONTROLLED ITEM TOP F1001001E 1103

SUPPLIER CODE



200340

01/21/2003



01/21/2003



MDS2

DELL

MDS 2

01/21/2003



01/21/2003



01/21/2003



01/21/2003



01/21/2003



01/21/2003



01/21/2003



01/21/2003



01/21/2003



01/21/2008

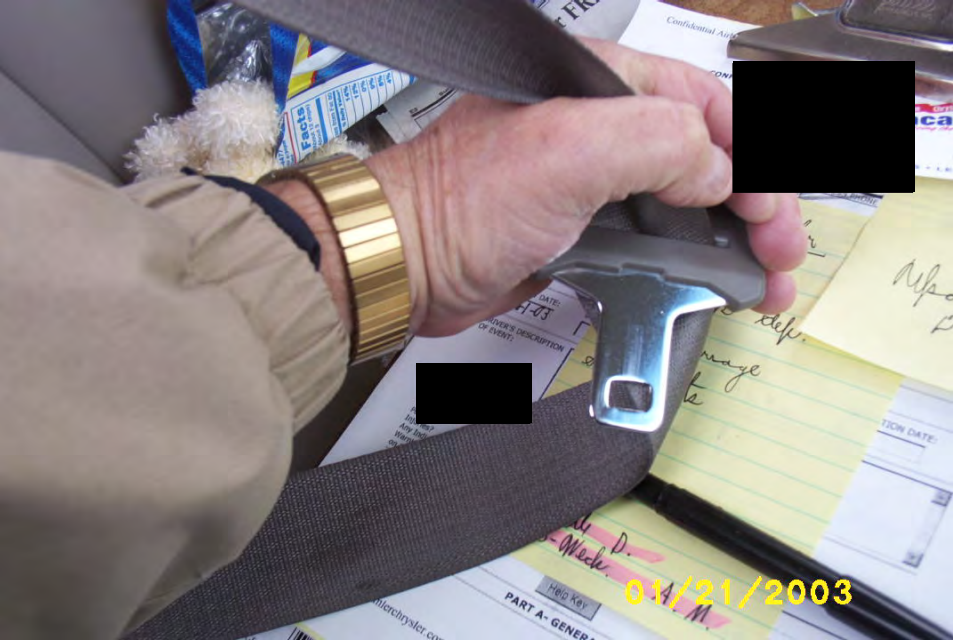

Confidential Air

Facts

DATE: 1-23
DRIVER'S DESCRIPTION OF EVENT:

Alpa

maye
Week

DATE:

01/21/2003

Help Key
PART A - GENERAL

chrysler.com



01/21/2003



01/21/2003



01/21/2003



Confidential Accident

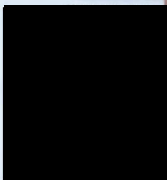

11-21-03

1. DRIVER'S DESCRIPTOR OF EVENT:

01/21/2003



Confidential Airline

01/21/2003



01/21/2003



01/21/2003



AIR
BAG



01/21/2003



01/21/2003

⚠ WARNING



**DEATH OR SERIOUS
INJURY CAN OCCUR**

- CHILDREN 12 AND UNDER CAN BE KILLED BY THE AIR BAG.
- THE BACK SEAT IS THE SAFEST PLACE FOR CHILDREN.
- NEVER PUT A REAR-FACING CHILD SEAT IN THE FRONT.
- SIT AS FAR BACK AS POSSIBLE FROM THE AIR BAG.
- ALWAYS USE SEAT BELTS AND CHILD RESTRAINTS.

⚠ WA



01/21/2003



01/21/2003



STY CARING
449-8900

01/21/2003



Jeep
LIBERTY

3.7L

01/21/2003



01/21/2003



01/21/2003



01/21/2003



01/21/2003



01/21/2003



01/21/2003

⚠ WARNING

DEATH OR SERIOUS INJURY CAN OCCUR



- CHILDREN 12 AND UNDER CAN BE KILLED BY THE AIR BAG.
- THE BACK SEAT IS THE SAFEST PLACE FOR CHILDREN.
- NEVER PUT A REAR-FACING CHILD SEAT IN THE FRONT.
- SIT AS FAR BACK AS POSSIBLE FROM THE AIR BAG.
- ALWAYS USE SEAT BELTS AND CHILD RESTRAINTS.

01/21/2003

MFD BY DAIMLERCHRYSLER CORPORATION DATE OF MFR 3-02 GVWR 2541 KG (85600 LB)

GVWR FRONT	WITH TIRES	RIMS AT	COLD
1180 KG (2600 LB)	235/70R16	16X7	227 KPA(33 PSI)
GVWR REAR	WITH TIRES	RIMS AT	COLD
1429 KG (3150 LB)	235/70R16	16X7	227 KPA(33 PSI)

THIS VEHICLE CONFORMS TO ALL APPLICABLE FEDERAL MOTOR VEHICLE SAFETY AND THEFT PREVENTION STANDARDS IN EFFECT ON THE DATE OF MANUFACTURE SHOWN ABOVE.

VIN: 1J8GL5BK32 [REDACTED]

TYPE:

MPV

SINGLE X DUAL



MDH: 831521 387AA PNT:PS2 VEHICLE MADE IN U.S.A. TRN:DL2 4648583

01/21/2003



01/21/2003



01/21/2003



01/21/2003

DODGE CHRYSLER JEEP

VACAVILLE NISSA

01/21/2003

DODGE CHRYSLER JEEP

NIS

NISSAN

01/21/2003



01/21/2003



01/21/2003



1/21/2003



110007
10835-D

01/21/2003



01/21/2003



01/21/2003



01/21/2003



01/21/2003

- Main Menu
1. DRB III Standalone
 2. Connect to MDS2
 3. Generic Scan Tool
 4. PEP Module Tools
 5. Run Memory Card Program
 6. DRB Utilities
 7. Vehicle Flash
 8. Legacy MDS1 Support

Page 1 of 1

HELP

Confidential Airbag

01/21/20

DRB III CDRB Application
DealerChrysler
Copyright © 1993-2001
All Rights Reserved
RELEASE 55.0 01
Released: 14:03:36 6/14/2002
Bios Version: 4.02
Database: 15:09:40 6/05/2002
Cable in use: J1962 (CH7000)

F1
HELP

55.0

F1 F2 F3 F4

01/21/20

Confidential Party 1



SELECT SYSTEM

1. Engine
2. Transmission
3. Body
4. Chassis
5. Anti-lock Brakes
6. Passive Restraints
7. Theft Alarm
8. System Monitors

Page 1 of 1

HELP SYS MAIN

55.0

F1 F2 F3 F4

ENTER

ENTER

↑

↑

↑

01/21/2

SELECT RESTRAINT SYSTEM

- 1. Airbag
- 2. Side Airbags
- 3. Airbag On/OFF Switch System

Page 1 of 1

HELP SYS MAIN

01/21/20

F1 F2 F3 F4

ENTER

This Diagnostic Control
Module is not supported by
this software. Please use the
DRB III with the Supercard
software to diagnose this
vehicle.

F1

SYS

MAIN

F1

F2

F3

F4

01/21/2003

Disable to ID Module for
DNC

press any key to continue

F1 F2 F3 F4



01/21/

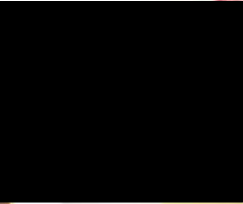



01/21/2003



01/21/2003



01/21/2003



01/21/2003

SRS
AIRBAG

01/21/2003

SRS
AIRBAG

01/21/2003



01/21/2003



01/21/2003



01/21/2003



707 449-8900

671 ORANGE DR. • VACAVILLE, CA 95687

FAX TRANSMISSION

To:

NAME <i>PORTERFIELD</i>	DATE AND TIME OF TRANSMISSION <i>March 4, 2003</i>
COMPLAINT <i>DANNON CHRYS SPECIAL INVESTIGATIONS</i>	FAX NUMBER <i>248-512-8748</i>

From:

NAME <i>DAVID LAW - 707-452-2546</i>	FAX NUMBER <i>(707) 452-7332</i>
---	-------------------------------------

Reference:

SUBJECT <i>DIRECT CHECK RENTAL REIMB.</i>
--

Message:

42 days rental for [REDACTED]
Coin # [REDACTED]

TOTAL RENTAL \$ 1,172.54
(PLEASE REFERENCE RD 135056.)

THANKS -
D. LAW

FORM REV. 8/00

MO 7:30A-6:00P TU 7:30A-6:00P
WE 7:30A-6:00P TH 7:30A-6:00P
FR 7:30A-6:00P SA 9:00A-2:00P

RENTAL TYPE		D		NO. 10		D		08855	
RENTER		ROBERTS		[REDACTED]		[REDACTED]		[REDACTED]	
ORIGIN VEHICLE		RAINFIELD		CA		[REDACTED]		[REDACTED]	
RAT. BL.		4VFT		[REDACTED]		[REDACTED]		[REDACTED]	
DRIVER'S LICENSE		[REDACTED]		CA		3/16/03		[REDACTED]	
BILL TO		COMPANY		DODGE/PLYMOUTH OF VACAVILLE**		[REDACTED]		[REDACTED]	
ADDRESS		471 ORANGE DR		VACAVILLE		CA 95687		[REDACTED]	
RENTAL ACCEPTS LIABILITY		RENTER		RENTER		RENTER		RENTER	
RENTER DECLINES LIABILITY		RENTER		RENTER		RENTER		RENTER	
ADDITIONAL AUTHORIZED DRIVER - NONE PERMITTED WITHOUT OWNER'S APPROVAL		SPOUSE		[REDACTED]		[REDACTED]		[REDACTED]	
PERMISSION TO LEAVE THE STATE OF RENTAL		YES		NO		NO		NO	
ACKNOWLEDGMENT OF THE ENTIRE AGREEMENT INCLUDING RENTAL AGREEMENT, TICKET JACKET		[REDACTED]		[REDACTED]		[REDACTED]		[REDACTED]	
DATE		1/16/03		[REDACTED]		[REDACTED]		[REDACTED]	
EMP.		[REDACTED]		[REDACTED]		[REDACTED]		[REDACTED]	
PAID BY		CASH		[REDACTED]		[REDACTED]		[REDACTED]	
RECEIPT FOR CASH REFUND		[REDACTED]		[REDACTED]		[REDACTED]		[REDACTED]	
CLAIM INFORMATION		POL. OR CL. #		31924		[REDACTED]		[REDACTED]	
LOSS DATE		[REDACTED]		[REDACTED]		[REDACTED]		[REDACTED]	
PHONE		707-449-8900		[REDACTED]		[REDACTED]		[REDACTED]	
REPAIR SHOP		DODGE/PLYMOUTH DE		[REDACTED]		[REDACTED]		[REDACTED]	
TYPE CAR		[REDACTED]		[REDACTED]		[REDACTED]		[REDACTED]	

DAY = 24 HOUR PERIOD
HOURS #
10.00 HOUR
42 DAYS *
25.00/DAY
25.00++
1082.00

OH 14.99/DAY
BAI 3.00/DAY
SLP 9.99/DAY

TAX 2.375
FUEL CHARGE 2.75/DOLLAR
80.34

TOTAL CHARGES 1172.54

DEPOSITS
REFUNDS
AMOUNT DUE 1172.54

DATE RECEIVED
CLAIM INFORMATION
POL. OR CL. # 31924
INSUR.
LOSS DATE
PHONE 707-449-8900
REPAIR SHOP DODGE/PLYMOUTH DE
TYPE CAR [REDACTED]

disclosure that damage waiver may be duplicative of coverage obtained under his or her own policy of motor vehicle insurance. purchase of damage waiver is not and may not be deemed to constitute an offer of insurance.

REPLACEMENT VEHICLE
LICENSE NO.
DATE RECEIVED
CLAIM INFORMATION

DROPPED RENTAL CHARGES
[REDACTED]



28635 Mound Road
Warren, Michigan 48092-3499
(586) 753-3326
FAX (586) 753-3335

Facsimile Cover Sheet
DaimlerChrysler Vehicle Investigation

Owner: [REDACTED]

Project No. DAIM-2003

CAIR No.: [REDACTED]

TO: Bob Lewis

FROM: Tina Martin

Date Sent: 01-21-03

DUE DATE: 01-24-03

***PLEASE ACKNOWLEDGE PROMPTLY BY FAX OR EMAIL**

***Receipt of CAIR and Accepting case for investigation?** Yes No

Date: 1-21-03

Coversheet for DaimlerChrysler (Service Associate Use Only)
(Also fax or email to EAA for closure)

*Closure Date: 1-22-03

DaimlerChrysler Fax No.: 248-512-8748

Bennis (248) 944-7036

Martell (248) 944-7038

Bott (248) 944-7056

Susalla (248) 944-7149

Gilbert (248) 944-7037

Porterfield (248) 944-7134

Comments: ATTACHMENTS: VACAVILLE D-C-J REPAIR
ORDERS (2).
Regard
Bob Lewis.



891 Orange Drive
 Vacaville, CA 95687
 (707) 449-8900
 EPA# CAL000224187
 BAR# AD183427

671 Orange Drive
 Vacaville, CA 95687
 (707) 452-7300
 EPA# CAL000148576
 BAR# AD216027

CAIR # 10850016

CUSTOMER NO. 36578	ACR# ORP AMY C PEARCE	428	TAG NO. 1503	INVOICE DATE 01/22/03	INVOICE NO. CHCS13182
FAIRFIELD, CA	LABOR RATE	LICENSE NO.	MILEAGE 16,181	COLOR SILVER/	STOCK NO. 16156
	YEAR / MAKE / MODEL 02 / JEEP / LIBERTY/UT LIBERTY LMTD			DELIVERY DATE 04/21/02	DELIVERY MILES 8
	VEHICLE I.D. NO. 1J8GL58K32W			SELLING DEALER NO. 1	PRODUCTION DATE
	F.T.E. NO.	P.O. NO.		PO# 01/22/03	
COMMENTS					MO: 1681

BAR# AD216027

LABOR & PARTS
 ELECTRICAL SYSTEM TECH# 3000 144.00
 PER CHRYSLER INSPECTOR INSPECT AND DIAGNOSE AIR BAG CONTROL MODULE COMMUNICATION
 PER CHRYSLER INSPECTOR
 DRB UNABLE TO IDENTIFY OR COMMUNICATE WITH ACM. CODE SET IN INSTRUMENT CLUSTER FOR NO ORC BUS MESSAGE RECEIVED. TEST PER DIAG MANUAL (BODY DTAG PROCEDURE) PAGE 249. THAT PAGE INSTRUCTED TO USE COMMUNICATION DIAG PAGE 174. NO RESPONSE FROM ACM. BOTH POWER SUPPLIES AND GROUND OK AT ACM AND PCT BUS WERE OK. MODULE HAS BURNT SMELL. MODULE NEEDS TO BE REPLACED PER DTAG MANUAL.
 JOB # 1 TOTAL LABOR & PARTS 144.00

ESTIMATE
 CUSTOMER HEREBY ACKNOWLEDGES RECEIVING ORIGINAL ESTIMATE OF \$144.00 (+TAX)

COMMENTS
 PARTS ETA 01/17 AIR BAGS, GLOCK SPRING AND BRACKET

TOTALS	
***** NEXT RECOMMENDED SERVICE 03/12/2003 / 19181 MI *****	
WE HERE AT DODGE CHRYSLER JEEP OF VACAVILLE AND NISSAN OF VACAVILLE LOOK FORWARD TO PROVIDING YOU AND YOUR VEHICLE WITH CONTINUOUS QUALITY SERVICE.	TOTAL LABOR 144.00
PLEASE REMEMBER OUR SERVICE HOURS	TOTAL PARTS 0.00
FROM 7:30 AM TO 6:00 PM MONDAY THROUGH FRIDAY	TOTAL SUBLET 0.00
PLEASE INITIAL HERE IF WE EXPLAINED THE REPAIRS/CHARGES	TOTAL B.O.B. 0.00
	TOTAL MISC CHG. 0.00
	TOTAL MISC DISC 0.00
	TOTAL TAX 0.00
	TOTAL INVOICE \$ 144.00

RECORD NUMBER: 887
 ACCOUNT: 441157613917674 88794
 NAME TYPE: 0168
 TRADE TYPE: SALE
 CITY CODE: 622544
 PROJECT: 144.00
 LEWIS ROBERT E
 I AGREE TO PAY ABOVE TOTAL AMOUNT ACCORDING TO HONO TROUSE AGREEMENT
 ACTION COPY CUSTOMER TOP COPY REPAIRMENT REPAIRMENT COPY

A I D
 JAN 22 2003
 CHECK VISA DISC
 DODGE CHRYSLER
 671 ORANGE DR
 VACAVILLE, CA 95687-3193
 707 449-8900
 REPAIRMENT TOP: 88624293
 DATE: 01/22/03 11:46:04 AM
 (JAN 22 2003)



681 Orange Drive
Vacaville, CA 95687
(707) 449-8900
EPA# CAL000224187
BAR# AD163427



571 Orange Drive
Vacaville, CA 95687
(707) 452-7300
EPA# CAL000148576
BAR# AD216027

135056

135056

RECOMMENDED SERVICES

OPERATION	OPERATION DESCRIPTION	MO/MI	TOTAL	OPERATION	OPERATION DESCRIPTION	MO/MI	TOT
26CHZ-LOF	LUBE OIL AND FILTER	MI	0.00				

SERVICE HISTORY

DATE	REPAIR ORDER	MI/LEAGE	ADVISOR	TECHNICIAN	TYPE	OPERATION	OPERATION DESCRIPTION
12/19/02	133656	14177	428	620	W	26CHZ-15KG	15000 MILES SERVICE
09/20/02	127896	8859	428	632	W	26CHZ-6KG	6000 MILES SERVICE
06/06/02	120784	3191	461	197	W	26CHZ-LOF	LUBE OIL AND FILTER
03/28/02	116224	1	429	415	I	40CHZ-PDI	NEW VEHICLE PDI

SALESPERSON NO. 477

S E R V I C E

STATE REG# AD216027

SAVE OLD PARTS? <input type="checkbox"/> YES <input type="checkbox"/> NO	VEHICLE I.D. NO. 1J8GL58K32W	YEAR/MAKE/MODEL 02/JEEP/LIBERTY/UT LIBERTY LMTD	PRODUCTION DATE 04/21/02	STOCK NO. 16156	LICENSE NO. 135056
TERMS CASH <input type="checkbox"/> CHARGE <input type="checkbox"/> CHECK <input type="checkbox"/>	VACAVILLE, CA F.F.	CUSTOMER NO. [REDACTED] SERVICE CONTRACT [REDACTED]	DELIVERY DATE 04/21/02	DELIVERY MILES 181	SELLING DEALER NO. 017403
APPOINTMENT <input checked="" type="checkbox"/> Yes <input type="checkbox"/> No	RESIDENCE PHONE [REDACTED] BUSINESS PHONE [REDACTED]	COLOR SILVER/	CONTRACT NO. [REDACTED]	EXPIRATION DATE [REDACTED]	EXPIRATION MILES [REDACTED]
TIME RECEIVED 02:19pm	DATE/TIME PROMISED 01/15/03 06:00pm	TURBO <input type="checkbox"/> M/MC <input type="checkbox"/> AIR COND <input type="checkbox"/> P/S <input type="checkbox"/> TRANS <input type="checkbox"/>	ADVISOR NO. 428	ADVISOR AMY C PEARCE	

COMMENTS: BEING TOWED IN - SEE AMY -

W: 21CHZ TRANS AUTO/MANU
CUSTOMER SAYS WHEN DRIVING 25-35 MPH VEHICLE HAS A CONTINUOUS HESITATION UNTIL ACCELERATES TO A STEADY SPEED. NO WARNING LIGHTS HAVE CAME ON. CHECK AND ADVISE.

W: 08CHZ ELECTRICAL SYSTEM
CUSTOMER WAS DRIVING, HEARD A CHIME DING, LOOKED DOWN AND BOTH DRIVER AND PASSENGER SIDE AIR BAGS DEPLOYED. TOWED IN, NO VISIBLE SIGNS OF IMPACT ON VEHICLE. CHECK AND ADVISE.

REVISED ESTIMATE DATE	REVISED PARTS ON ORDER	REVISED ESTIMATE (\$)
TIME Date	Technician	
PERSON CONTACTED	[Handwritten signature]	
PHONE #	By: [Handwritten signature]	

NOTES: BAR# AD216027
 Also Rec'd 1/14/03 - 3800.
 1/17/03 - Rec'd - will contact speed
 059 AM
 [Handwritten notes about parts and contact info]



2144 Merritt Place
Fairfield, CA 94533

facsimile transmittal

To: Mr. Potterfield Fax: (248) 512-8748

From: [Redacted] Date: 03/12/03

Re: Claim [Redacted] Pages: 2

CC:

Urgent For Review Please Comment Please Reply Please Recycle

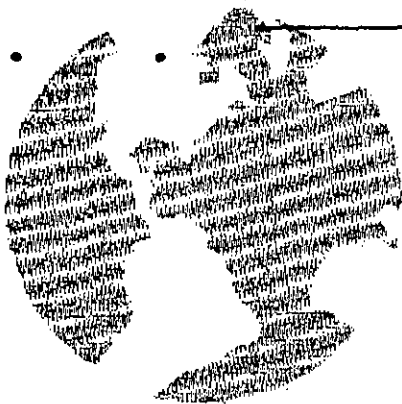

[Faded, illegible text at the bottom of the page, possibly a footer or contact information.]

March 12, 2003

Mr. Porterfield:

In regards to our conversation on Tuesday, February 18, 2003 regarding my claim file # [REDACTED]

In response to your request I have reached a fair and reasonable sum of \$63,363.70. The breakdown is as follows:

-	Lost wages (Nine days following incident)	\$ 1,713.70
-	Lost wages (to date after returning to work)	600.00
-	Medication	40.00
-	Car payments (2 months)	1,010.00
-	Mental Anguish	15,000.00
-	Pain and suffering to back, neck, and left arm	25,000.00
-	Release of any future claim due to Lost wages, medical, medication, etc.	25,000.00
	Total	\$63,363.70

Upon your review and agreement of this request, I release all future liability caused by the malfunction of my 2002 Jeep air bag unit.

Please contact me within 3-5 business days from today by phone or by certified check at the phone number or address below.

Thanks again for your immediate assistance in this matter.

Sincerely,

[REDACTED]
 Fairfield, CA [REDACTED]
 [REDACTED]

cairnumber :10850016

CONFIDENTIAL - Prior Approval Required Before Duplicating

Preliminary Vehicle Investigation Report(PVIR)

CAIR# 10850016

YEAR	BRAND	VEHICLE IDENTIFICATION NUMBER		MO/DY-HR	ODOMETER	SERVICE DATE
2002	JEEP LIBERTY LTD EDITION 4X4 SPORT UTILITY 4-DR	1J8GL58K32W [REDACTED]		03-15 21	19323	04/21/2002
NAME OF OWNER		ADDRESS/LOCATION		CITY		STATE
[REDACTED]		[REDACTED]		FAIRFIELD		CA
ZIP	COLOR	MODEL	HOME PHONE		BUSINESS PHONE	
[REDACTED]	Bright Silver Metallic Clear Coat	KJJ	[REDACTED]			
SELLING DEALER NAME		ZONE	DLR. CODE	CITY	STATE	
DODGE-CHRY-JEEP OF VACAVILLE		71	44517	VACAVILLE	CA	
INSPECTOR - NAME FIRST, LAST, MIDDLE			INSPECTOR'S COMPANY		INSPECTOR'S PHONE NO.	
BOB LEWIS E			EAA		916-782-8712	
DAMAGE ESTIMATE				REPAIR ESTIMATE		
<input checked="" type="radio"/> MINOR <input type="radio"/> MODERATE <input type="radio"/> TOTAL LOSS				\$ 1.00		

INTERVIEW

INTERVIEW WITH:

DRIVER OWNER OTHER DRIVER/OWNER

NAME: LAST, FIRST, MIDDLE

[REDACTED]

INTERVIEW DATE:

DATE OF INCIDENT:

TIME OF INCIDENT

INSPECTION DATE:

01/21/2003

01/14/2002

02:00 AM PM

01/22/2003

1. DRIVER'S

DESCRIPTION OF EVENT:

MS. [REDACTED] OWNERS' FRIEND, WAS DRIVING ON A SMOOTH RESIDENTIAL ROAD, WHEN THE AIR BAGS SUDDENLY DEPLOYED, WITH NO IMPACT TO THE VEHICLE. HER INSURANCE COMPANY INSPECTED THE VEHICLE ON 01/21/2003 AND INFORMED HER IT IS DC'S RESPONSIBILITY AND THEY ARE NOT HANDLING HER CLAIM.

Insurance

Company

USAA

Name:

Personal Injury:

Were there

Personal

Injuries?

Any Indicator/

Warning Lights

on Prior?

Yes No

Yes No

If Yes, complete section "B"

If Yes, What light: **CHIME WENT OFF**

IMPORTANT: SHOW THIS REPORT TO NO ONE & ONLY STATE FACTS (DRAW NO CONCLUSIONS)

Help Key

PART A- GENERAL

REQUIRED PHOTOGRAPHS:

ALL FOUR SIDE VIEWS

IF CRASH DAMAGED:

PERSPECTIVE FROM EVERY CORNER OF VEHICLE DOWN BOTH ORIGINAL LATERAL SIGHT LINES(8 TOTAL)

- ANY RECENT VEHICLE SERVICE

YES NO

UNKNOWN

IF YES, ENCLOSE COPIES OF REPAIR ORDERS

INFORMATION:

POLICE/AGENCY REPORT #:

NONE

ALL REPORTS/PHOTOS BY OTHERS

- ADDRESS OF INSPECTION

Address **VACAVILLE D-C-J**

1

Address **681 ORANGE DR.**

2

City **VACAVILLE**

State **CA**

Zip **95687**

PHONE

- EVIDENCE OF TAMPERING OR PRIOR DISASSEMBLY

YES NO

- IF YES, DESCRIBE AND PHOTOGRAPH

PART B - EXTERIOR/INTERIOR VEHICLE DAMAGE

REQUIRED PHOTOGRAPHS:

WINDSHIELD

ALL AREAS OF DAMAGE MARKINGS ON INTERIOR AND EXTERIOR

CLOSE UPS OF STAINS, SKIN, HAIR, CLOTH

EXTERIOR AND INTERIOR DAMAGE INCLUDING UNDERCARRIAGE

INFORMATION:

DESCRIBE ANY INJURIES TO DRIVER AND/OR OTHER OCCUPANTS

SEE SEAT BELT/SEATS SECTION IF APPLICABLE

AIR BAG DEPLOYMENT INJURED MS. [REDACTED] NECK, SHOULDER AND ARM. SHE WAS TREATED BY DOCTOR [REDACTED] 01/22/2003-NO DAMAGE TO THE EXTERIOR OR UNDERCARRIAGE OF THE VEHICLE.

Next

PART C - AIRBAG(S)

REQUIRED PHOTOGRAPHS

- STEERING WHEEL
- AIRBAG(S)
- KNEE BLOCKERS
- ALL POSSIBLE LOCATIONS OF CONTACT

AECM INFORMATION

- SOFTWARE VERSION:

N/A

- SERIAL NUMBER :

N/A

- PART NUMBER :

N/A

- DOES AIRBAG WARNING LIGHT CYCLE ON?

YES NO N/A

- ARE WARNING LABELS PRESENT (PHOTO)

YES NO N/A

- RECORD LABEL PART NUMBER

NONE

COMPLETE PART D

- PHOTOGRAPH REQUIRED FOR DRB SCREENS & RECORD FAULTS
 - WERE THERE DRB READINGS TAKEN?

YES NO IF NO, EXPLAIN

AIR BAG MODULE SHORTERED.

- RECORD ACTIVE DTC'S EXACTLY AS APPEAR :	MIN	COUNT
SEE COMMENTS		
- RECORD STORED DTC'S (MINUTES/COUNTS) :	MIN	COUNT
SEE COMMENTS		

- WAS AIRBAG DEPLOYED?

DRIVER YES NO

IF NO, EXPLAIN

PASSENGER YES NO

IF NO, EXPLAIN

SIDE AIRBAG YES NO N/A

IF NO, EXPLAIN

SEE PHOTOS

- WHICH SIDE DEPLOYED?

LEFT RIGHT N/A BOTH

- TYPE OF SIDE AIRBAG

SEAT CURTAIN N/A

- TYPE OF STEERING WHEEL

TILT STANDARD

- ANY DAMAGE TO STEERING WHEEL

YES NO

IF YES, EXPLAIN

DO NOT ERASE DRB READINGS

IS VEHICLE EQUIPPED WITH PASSENGER AIRBAG DEFAULT SWITCH?

YES NO

IF YES,

NOTE POSITION OF PASSENGER A/B SWITCH

ON OFF N/A

- EVIDENCE OF TAMPERING OR DISASSEMBLY?

YES NO N/A

IF YES, EXPLAIN

CHECK ENTIRE UNDERBODY FOR HIDDEN DAMAGE INCLUDING FRONT AND REAR SUSPENSION COMPONENTS

- UNDERBODY DAMAGED?

YES NO

IF YES, EXPLAIN

PHOTOGRAPH REQUIRED

PART D - SEATS/SHOULDER BELTS

REQUIRED PHOTOGRAPHS:

- OVERALL SEAT BELTS I/B & O/B
- CLOSE UP OF ANY IRREGULARITIES
- LATCHPLATE WEAR
- CLOSE UP D-RING TO SHOW LOADING
- OVERALL OF SEAT
- CLOSE UP OF DAMAGE
- RECORD DTC'S:

INFORMATION:

- LOCATE SEAT BELT LABELS AND RECORD ALL INFORMATION (SOME LABELS ARE SEWN TO WEBBING, OTHER LABELS ARE ON THE RETRACTOR FRAME: INBOARD SEAT BELT LABELS ARE NEAR THE FLOOR):

NONE

- RECORD ALL INFORMATION STAMPED ON LATCHPLATE

DRIVER-TD071-33014254-D22
PASSENGER-TD061-33014254-D22

- PRETENSION DEPLOYED?

YES NO UNKNOWN

- EXISTING LOCATION OF RECLINER - DESCRIBE THE LOCATION AND PICTURE OF SEAT BACK WITH B PILLOR AS REFERENCE AND INCLINOMETER READING

SEE PHOTOS

EXISTING LOCATION OF HEAD RESTRAINT (MEASURE GAP UNDER HEAD RESTRAINT):

IF ALLOWED. FUNCTION BELTS TO INSURE THEY **FUNCTION PROPERLY**

NOTE RESULTS

- DOES THE BUCKLE LATCH?

YES NO

IF NO, EXPLAIN

- DO THEY RELEASE?

YES NO

IF NO, EXPLAIN

- DO THEY RETRACT?

YES NO

IF NO, EXPLAIN

- ANY LOOSENESS OR BROKEN PARTS

YES NO

IF YES, EXPLAIN?

- CHECK FOR SEAT RETAINING BOLTS

NORMAL

BROKEN

LOOSE

MISSING

- NOTE AND RECORD APPROX. SEAT TRACK OVERLAP

SEE PHOTOS

PART - E TRANSMISSION NOT APPLICABLE

Previous

Next

PART - F UNINTENDED ACCELERATION NOT APPLICABLE

PART - G BRAKES NOT APPLICABLE

PART - H STEERING/SUSPENSION/TIRES NOT APPLICABLE

PART I - AXLE/DIFFERENTIAL

REQUIRED

PHOTOGRAPHS:

ENTIRE AXLE AND
CLOSE UP OF LEAKS

INFORMATION:

- VEHICLE ON HOIST:

REAR WHEEL DRIVE:

- RECORD AMOUNT OF LATERAL AXLE MOVEMENT OF EACH SIDE AND WILL WHEELS
TURN:

TRANS. AXLE - ROTATE WHEELS

- NOTE FUNCTION:

PART J - ADDITIONAL COMMENTS (DO NOT DRAW ANY CONCLUSIONS)

01/21/2003-CALLED VACAVILLE D-C-J AND ARRANGED TO INSPECT THE VEHICLE ON 01/22/2003, A.M.
CALLED OWNER, NOT IN, LEFT MESSAGE. 01/21/2003-P.M.-CONTACTED DRIVER, MS. [REDACTED] AND
INTERVIEWED HER FOR ADDITIONAL FACTS ON THE INCIDENT. INSPECTED VEHICLE AND TOOK PHOTOS
AT VACAVILLE D-C-J. RAN DRB ON THE AIR BAG SYSTEM. COMPLETED ALL THE INFORMATION AND
PHOTOS OUTLINED ON THE PVIR FOR SEAT BELTS AND AIR BAGS. ADDITIONAL COMMENTS ARE
OUTLINED BELOW: *NO EXTERIOR OR UNDERCARRAGE DAMAGE. *TUG TEST ON THE SEAT BELTS
INDICATE THEY LOCK. *AIR BAG LIGHT STAYS ON. *DRB TEST WAS NOT ABLE TO OBTAIN ANY DTC`S.
DRB SCREEN MESSAGE WAS "UNABLE TO ID MODULE FOR ORC." *TECNICIAN, GREG PARSONS, AT
DEALERSHIP AND I, USING THE 2002 "BODY DIAGNOSIS SHOP MANUAL" DIAGNOSED THE NO
COMMUNICATION MESSAGE ON THE DRB TEST. REPAIR ORDER #135582 OUTLINES THE TESTS USED TO
LOCATE THE SHORTED AIR BAG MODULE CONCERN. AIR BAG MODULE WAS REMOVED AND HAD A BURNT
ELECTRICAL SMELL. *AIR BAG MODULE CODES FOLLOW: CHRY. PIN-P560105AG. CHRY. SIN-
TSPME0702E119339754C. CONTACTED ROY PORTERFIELD AT DC TO INFORM HIM OF THE AIR BAG
MODULE CONCERN. COMPLETED THE PVIR AND E-MAILED WITH THE PHOTOS TO DC. FAXED THE REPAIR
ORDERS TO DC.

Previous

10.96/678

Gene's Chrysler



DODGE



Jeep.



3400 Cushman Street
Fairbanks, Alaska 99701
907-452-7117
907-458-3247 fax
www.geneschrysler.com

FAX COVER SHEET

3 Pages to follow

TO Dave Bennis.

Message _____

Claim for 2003 Liberty air bag
deployment. Refer to Car# [REDACTED].

From: Kathy Immel

Date 04-02-03

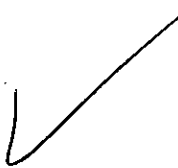

64398

WARRANTY

PAGE 1

HOME:

BUS:

SERVICE ADVISOR: 359 ROXY MARCY

COLOR	YEAR	MAKE/MODEL	VIN	LICENSE	MILEAGE IN/ OUT	TAG	
BLU	03	JEEP LIBERTY	1J4GL48K73W [REDACTED]		16/28	T9709	
DEL DATE	PROD. DATE	WARR. EXP.	PROMISED	PO NO.	RATE	PAYMENT	INV. DATE
			17:00 25MAR03			CASH	25MAR2003

R.O. OPENED READY OPTIONS: STK:2364181 DLR:63826 ENG:3.7 TRN:MANU
 09:50 21FEB03 15:24 25MAR03 **REFER TO CAIR # [REDACTED]**

LINE	OPCODE	TECH	TYPE	HOURS	LIST	NET	TOTAL
------	--------	------	------	-------	------	-----	-------

A AIR BAG DEPLOYED WHILE IDLING
 CAUSE: SEE TECH NOTES

08900201	WIRING HARNESS, AIR INSTRUMENT PANEL	08909001 (3.4)	→ 255.68
	CONDITIONING/HEATER Replace (C)	08901509 (1.5)	→ 112.80
479	W 2.90		218.08 → 218.08
1	56010509AG WIRING	317.00	266.00 266.00
1	56010364AG WIRING-INSTRUMENT PANEL	300.00	252.00 252.00
1	5HG331DVAH SEAT BELT-FRONT OUTER	260.00	218.40 218.40
1	55315033AC SLIDE-SEAT BELT TURNING L	25.00	21.00 21.00
1	FRT FREIGHT	35.00	35.00 35.00
1	DAY FRT CHARGE		
1	FRT FREIGHT	146.67	146.67 146.67
SH	FRT CHARGE		
1	5066386AA *COOLANT	14.25	12.39 12.39
	FC: PART#: COUNT:		
	CLAIM TYPE:		
	AUTH CODE:		
	2663		
08906504	WIRING HARNESS, ENGINE COMPARTMENT AND HEADLAMP-Replace (B)		
479	W 1.20		90.24 90.24
1	56009954AP WIRING-HEADLAMP TO DASH	430.00	361.20 361.20
	FC: PART#: COUNT:		
	CLAIM TYPE:		
	AUTH CODE:		
	2663		
23115001	AIRBAG, PASSENGER-Replace (A)		N/C
479	W 0.50		37.60 → 37.60
1	5GG30DX9AE AIRBAG	397.00	333.20 333.20
	FC: PART#: COUNT:		
	CLAIM TYPE:		
	AUTH CODE: F		
	2663		
06142522	SENSOR, AIR BAG IMPACT-Replace (H) only left Replaced		

DEALERSHIP WARRANTY

 90 DAYS OR 4,000 MILES ON PARTS & LABOR.
 CHRYSLER (MOPAR) LIMITED WARRANTY

 12 MONTHS OR 12,000 MILES PARTS & LABOR.

STATEMENT OF DISCLAIMER
 All warranties on the product sold hereby are those made by the manufacturer. The Seller, GENE'S CHRYSLER, hereby expressly disclaims all warranties, either express or implied, including any implied warranty of merchantability or fitness for a particular purpose, and GENE'S CHRYSLER neither assumes nor authorizes any other person to assume for it any liability in connection with this sale. Not responsible for loss or damage to car or articles left in cars in case of fire, theft or any other cause beyond our control. I hereby authorize the above repair work to be done along with the necessary material and hereby grant you and/or your employees permission to operate the vehicle described on the streets, highways or elsewhere for the purpose of testing and/or inspection. An express mechanic's lien is hereby acknowledged on the above vehicle to secure the amount of repairs thereto.
 CUSTOMER SIGNATURE

DESCRIPTION	TOTALS
LABOR AMOUNT	
PARTS AMOUNT	
GAS, OIL, LUBE	
SUBLET AMOUNT	
MISC. CHARGES	
TOTAL CHARGES	
LESS INSURANCE	
SALES TAX	
PLEASE PAY THIS AMOUNT	

64398

WARRANTY

PAGE 2

HOME:

BUS:

SERVICE ADVISOR: 359 ROXY MARCY

COLOR	YEAR	MAKE/MODEL	VIN	LICENSE	MILEAGE IN/ OUT	TAG
BLU	03	JEEP LIBERTY	1J4GL48K73W		16/28	T9709
DEL DATE	PROD. DATE	WARR. EXP.	PROMISED	PO NO.	RATE	PAYMENT
			17:00 25MAR03			CASH
R.O. OPENED	READY	OPTIONS: STK:2364181 DLR:63826 ENG:3.7 TRN:MANJ				
09:50 21FEB03	15:24 25MAR03					

LINE	OPCODE	TECH	TYPE	HOURS	LIST	NET	TOTAL	
		479	W	0.30		22.56	22.56	
08142503		SENSOR, AIR BAG IMPACT-Replace (B)						
		479	W	0.30		22.56	22.56	
1	56010319AB	SENSOR			37.10	31.15	31.15	
	FC: PART#: COUNT:							
	CLAIM TYPE:							
	AUTH CODE:							
	2663							
08450901		MODULE, AIR BAG/OCCUPANT RESTRAINT CONTROL-Replace (A)						
		479	W	0.40		30.08	30.08	
1	56010501AI	MODULE-OCCUPANT RESTRAINT			114.00	95.69	95.69	
	FC: PART#: COUNT:							
	CLAIM TYPE:							
	AUTH CODE:							
	2663							
19852502		CLOCKSPRING-Replace (B)						
		479	W	0.40		30.08	30.08	
1	56010146AE	CLKSPRING			110.00	92.33	92.33	
	FC: PART#: COUNT:							
	CLAIM TYPE:							
	AUTH CODE:							
	2663							

120240 186503 TPARTS
21837 45120 TLABOR

28 REMOVED INSTRUMENT PANEL & FRONT SEATS & ALSO ALL FRONT TRIM PANELS, REMOVED INSTRUMENT PANEL WIRING HARNESS & REMOVED FRONT BODY WIRING HARNESS & REPLACED BOTH WIRING HARNESS'S, REMOVED HEADLAMP TO I/P HARNESS & REPLACED ALSO WITH NEW WIRING HARNESS, REPLACED FRONT AIR BAG IMPACT SENSORS, REPLACED AIR BAG CONTROL MODULE FOR HAVING SHORDED & CAUSING LEFT AIR BAG & SEAT BELT TO DEPLOY WITHOUT VEHICLE BEING IMPACTED OR HIT, INSTALLED ALL NEW WIRING & SENSORS & AIRBAG CONTROL MODULE, & SEAL BELT ASSY. REINSTALLED RADIATOR, RADIATOR WAS REMOVED TO GET TO FRONT WIRING, FILLED WITH COOLANT & VERIFIED THAT ALL AIR WAS OUT OF

DEALERSHIP WARRANTY *** 90 DAYS OR 4,000 MILES ON PARTS & LABOR. CHRYSLER (MOPAR) LIMITED WARRANTY *** 12 MONTHS OR 12,000 MILES PARTS & LABOR.	STATEMENT OF DISCLAIMER	
	All warranties on the product sold hereby are those made by the manufacturer. The Seller, GENE'S CHRYSLER, hereby expressly disclaims all warranties, either express or implied, including any implied warranty of merchantability or fitness for a particular purpose, and GENE'S CHRYSLER neither assumes nor authorizes any other person to assume for it any liability in connection with this sale. Not responsible for loss or damage to car or articles left in cars in case of fire, theft or any other cause beyond our control. I hereby authorize the above repair work to be done along with the necessary material and hereby grant you and/or your employees permission to operate the vehicle described on the streets, highways or elsewhere for the purpose of testing and/or inspection. An express mechanic's lien is hereby acknowledged on the above vehicle to secure the amount of repairs thereto.	
	LABOR AMOUNT	TOTALS
	PARTS AMOUNT	
	GAS, OIL, LUBE	
	SUBLET AMOUNT	
	MISC. CHARGES	
	TOTAL CHARGES	
	LESS INSURANCE	
	SALES TAX	
CUSTOMER SIGNATURE	PLEASE PAY THIS AMOUNT	

6 4 3 9 8

WARRANTY

PAGE 3

HOME:

BUS:

SERVICE ADVISOR: 359 ROXY MARCY

COLOR	YEAR	MAKE/MODEL	VIN	LICENSE	MILEAGE IN/ OUT	TAG	
BLU	03	JEEP LIBERTY	1J4GL48K73W		16/28	T9709	
DEL DATE	PROD. DATE	WARR. EXP.	PROMISED	PO NO.	RATE	PAYMENT	INV. DATE
			17:00 25MAR03			CASH	25MAR2003
R.O. OPENED	READY	OPTIONS: STK:2364181 DLR:63826 ENG:3.7 TRN:MANU					

09:50 21FEB03	15:24 25MAR03						
LINE	OPCODE	TECH	TYPE	HOURS	LIST	NET	TOTAL

SYSTEM, REINSTALLED FRONT SEATS, REINSTALLED INSTRUMENT PANEL, REINSTALL GAUGE CLUSTER & RADIO & REINSTALL HEATER, CONTROLS, ALS O REINSTALLED STEERING COLUMN WITH NEW CLOCK SP RING & REINSTALL TURN SIGNAL ASSY., REINSTALL B GLOVE BOX & ALL TRIM PANEL FOR I/P, & DOOR SILLS AND KICK PANELS, TEST DROVE AFTER REINSTALLING ALL PARTS NO AIR BAG LIGHTS CAME ON & NO OTHER DTCS WERE PRESENT DROVE FOR TWELVE MILES NO PROBLEMS FOUND & NO RATTLING FOUND FROM TRIM.

B** PRE PAID FRIEGHT

CAUSE:

0 FREIGHT

479	W	0.00					
1	FRT FREIGHT				11.54	11.54	11.54
FC:	PART#:	COUNT:					
CLAIM	TYPE:						
AUTH	CODE:						
2663							

pre-paid freight

0 1154 TPARTS
0 0 TLABOR

28

COST, SALE, & COMP TOTALS 142077 232777 0

DEALERSHIP WARRANTY 90 DAYS OR 4,000 MILES ON PARTS & LABOR. CHRYSLER (MOPAR) LIMITED WARRANTY 12 MONTHS OR 12,000 MILES PARTS & LABOR.	STATEMENT OF DISCLAIMER All warranties on the product sold hereby are those made by the manufacturer. The Seller, GENE'S CHRYSLER, hereby expressly disclaims all warranties, either express or implied, including any implied warranty of merchantability or fitness for a particular purpose, and GENE'S CHRYSLER neither assumes nor authorizes any other person to assume for it any liability in connection with this sale. Not responsible for loss or damage to car or articles left in cars in case of fire, theft or any other cause beyond our control. I hereby authorize the above repair work to be done along with the necessary material and hereby grant you and/or your employees permission to operate the vehicle described on the streets, highways or elsewhere for the purpose of testing and/or inspection. An express mechanic's lien is hereby acknowledged on the above vehicle to secure the amount of repairs thereto.	DESCRIPTION	TOTALS
		LABOR AMOUNT	451.20
PARTS AMOUNT	1876.57		
GAS, OIL, LUBE	0.00		
SUBLET AMOUNT	0.00		
MISC. CHARGES	0.00		
TOTAL CHARGES	2327.77		
LESS INSURANCE	0.00		
SALES TAX	0.00		
CUSTOMER SIGNATURE	PLEASE PAY THIS AMOUNT	2327.77	

7541.44

WARRANTY COPY

2406.47

April 7, 2003

Jeans Chrysler Jeep
Attn: Kathy Immel
3400 S. Cushman Street
Fairbanks, AK 99701

Reference No.: [REDACTED]

V.I.N.: 1J4GL48K73W [REDACTED]

Dear Mr. Immel:

Enclosed you will find DaimlerChrysler check number 6320554 in the amount of \$2,406.47.

The amount of this check will represent reimbursement for the repairs performed on Mr. [REDACTED]' 2003 Jeep Liberty Sport.

Thank you for your courtesy and cooperation in the repair of this vehicle.

Sincerely,

D. M. Bennis
Special Investigations
(248) 944-7036

DMB/kat

Enclosure(s)

VENDOR NO: SU00000001
VENDOR LOC:
FACTOR VENDOR:
FACTOR VENDOR LOC:

REMITTANCE ADVICE
DAIMLERCHRYSLER CORPORATION
CIMS: 431-00-00
P.O. BOX 21-8004
AUBURN HILLS MI 48321-8004

PAY REF. NO: [REDACTED]
DATE: 04/04/2003
PH: USCKU SOURCE: SU
MAIL: R:SU

INV/REF DATE	INVOICE/REFERENCE NUMBER-SCHEDULE PAY NO.	GROSS AMOUNT	DISCOUNT AMOUNT	NET AMOUNT
04/03/2003 ZONE 82	[REDACTED] VIN 1J4GL48K73M [REDACTED]	2,406.47		2,406.47
TOTALS		2,406.47		2,406.47

REMOVE CHECK ALONG THIS PERFORATION

THIS CHECK HAS A SECURITY FEATURE THAT WILL APPEAR IF ALTERED.

DAIMLERCHRYSLER GAP CHASE-MANHATTAN BANK USA, N.A.
WILMINGTON, DELAWARE

62-26 1530-09 0006320554
311

DATE: 04/04/2003 SEQUENCE NO. 00036 PAY: 5000000000002406AND47CENTS *****2406.47

PAY TO THE ORDER OF [REDACTED] VOID SIX MONTHS AFTER DATE OF ISSUE
ACCOUNT 7601 BANK USCKU
DAIMLERCHRYSLER CORPORATION
AUTHORIZED SIGNER
T.P. Dykstra

FAIRBANKS AK [REDACTED]

1587218

SEE REVERSE SIDE FOR OPENING INSTRUCTIONS

DAIMLERCHRYSLER
CORPORATE PAYMENTS GAP
CIMS: 431-00-00
P.O. BOX 21-8004
AUBURN HILLS MI 48321-8004

USCKU SU 0006320554 R:SU

FAIRBANKS AK [REDACTED]

2855-0709-0222 Moon North America ©2000, SecureScan® Patents 5,018,767; 5,193,853; and other patents pending. PressureSeal Patent 4,918,128. - 0221

10961678

[REDACTED]
Fairbanks, AK [REDACTED]

urgent

f a c s i m i l e

To: Dave Bennis
Fax Number: 91-248-512-8748,,,2094

From: Jim Scoles
Fax Number: 907-458-3251
Business Phone: 907-458-3250
Home Phone:

Pages: 6
Date/Time: 2/25/2003 12:44:42 PM
Subject: CAIR # [REDACTED]

Kelly & Dave,

Attached you will find documentation regarding 03 Jeep Liberty that dispatched the airbag. I will await your response to move forward. I am not a lawyer but when you read the Alaska Statute's it appears we have exceeded the 5% rule for "replacement" vs repair.

Dave - just let Kelly or I know if you want photo's for the module we took from vehicle. Thanks for you rtime.

Respectfully,
Jim Scoles

ESTIMATE

DATE: 25Feb03

Fairbanks, AK [REDACTED]

To: Dave Bennis
 Daimler Chrysler Corp
 Special Investigations
 Fax: 248-512-8748
 Voice: 248-944-7036

Phone: 907-458-3250 direct line
 Estimated By: Jim Scoles - S & P Director
 Start Date: Upon your approval
 Location: [REDACTED]
 Job Phone: [REDACTED]

TERMS: Net 30 Days

JOB DESCRIPTION

Repair as directed by DCX for airbag deploying without an event present – Special Investigations report on file with DCX by David B. Vial

***** Mr. Bennis: please note, Rick Monsey (Shop Foreman) disassembled control module and found burnt "computer chip" in module. I have taken digital photos. Will forward those photos to DOM – Kelly Linn. If you Request them, please contact Kelly unless you want to send your e-mail address to jims@geneschrysler.com I will be happy to send directly to you. Thanks–jbs

ITEMIZED ESTIMATE

Part list and labor on attached documents-----	
Parts total with markup	\$1968.12
Labor – total 9.9hrs sold @ \$75.20 per hr Warranty Rate	\$744.48
TOTAL ESTIMATED JOB COST	\$2712.60

***** Note – MSRP = \$20,830 – total repair far exceeds Alaska Statute 45.25.510 (attch)

This is an estimate only, not a contract for services. This estimate is for completing the job as described above. It is based on our evaluation and does not include material price increases or additional labor and materials which may be required should unforeseen problems arise after the work has started.

Page 19 line 11

Sec. 45.25.510. Disclosure of damages.

(a) Before entering into a new motor vehicle sales contract, a new motor vehicle dealer shall disclose in writing to a buyer of the new motor vehicle any known damage and repair to the new motor vehicle if the damage exceeds five percent of the manufacturer's suggested retail price as calculated at the dealer's authorized warranty rate for labor and parts or \$1000.00 whichever is greater. A new motor vehicle dealer is not required to disclose to a buyer that glass, tires, bumpers, or cosmetic parts of a new motor vehicle were damaged at any time if the damaged item has been replaced with original or comparable equipment. A replaced part is not part of the cumulative damage required to be disclosed under this subsection.

(b) If disclosure is not required under this section, a buyer may not revoke or rescind a sales contract due to the fact that the new motor vehicle was damaged and repaired before completion of the sale.

(c) In this section,

(1) "cosmetic parts" means parts that are attached by and can be replaced in total through the use of screws, bolts, or other fasteners without the use of welding or thermal cutting and includes windshields, bumpers, hoods, or trim panels;

(2) "manufacturer's suggested retail price" means the retail price of the new motor vehicle suggested by the manufacturer and includes the retail delivered price suggested by the manufacturer for each accessory or item of optional equipment physically attached to the new motor vehicle at the time of delivery to the new motor vehicle dealer that is not included within the retail price suggested by the manufacturer financing approval.

Page 21 line 18

(d) If a buyer's final financing is not approved **[within seven business days**



FAIRBANKS, ALASKA



Parts Hotline)
Parts Dept. Fax)

NO RETURNS ON ELECTRICAL OR SPECIAL ORDERED PARTS.
ALL RETURNS ARE SUBJECT TO A 20% HANDLING CHARGE.

ALL PARTS RETURNED FOR CREDIT MUST BE IN ORIGINAL PACKAGE WITH PURCHASE INVOICE OR CREDIT WILL BE REFUSED.

DISCLAIMER OF WARRANTIES: Any warranties on the products sold hereby are those made by the manufacturers. The seller hereby expressly disclaims all warranties, either express or implied, including any implied warranty of merchantability or fitness for a particular purpose, and neither assumes nor authorizes any other person to assume for it any liability in connection with the sale of said products.

Table with columns: DATE ENTERED (25 FEB 03), YOUR ORDER NO., DATE SHIPPED (25 FEB 03), INVOICE DATE, INVOICE NUMBER (44343)

SOLD TO

ACCOUNT NO. 98

SHIP TO

PAGE 1 OF 1
Q44343

CASH WHOLESALE

CAIR# [REDACTED]
2003 JEEP LIBERTY

Main invoice table with columns: SHIP VIA, SLSM, B/L NO., TERMS, F.O.B. POINT, QUANTITY, PART NO., DESCRIPTION, LIST, NET, AMOUNT. Includes handwritten notes and a signature line.

THANK YOU FOR YOUR BUSINESS!

CUSTOMER COPY

6 4 3 9 8

CUSTOMER #:

WORKORDER

PAGE 1



HOME:

BUS:

SERVICE ADVISOR: 359 MARCY, ROXY

COLOR	YEAR	MAKE/MODEL	VIN	LICENSE	MILEAGE IN/ OUT	TAG
BLU	03	JEEP LIBERTY	1J4GL48K73W [REDACTED]		16 1/	T9709
DEL DATE	PROD DATE	WARR EXP	PROMISED	PO	RATE	PAYMENT
			17:00 28FEB03			CASH
R.O. OPENED	READY	OPTIONS: STK:2364181 DLR:63826 ENG:3.7 TRN:MANU				
21FEB2003 09:50						

LINE	OP CODE	TECH	TYPE	DESCRIPTIONS/INSTRUCTIONS
# 1	A	S100	W	AIR BAG DEPLOYED WHILE IDLING

Ken

2-21-03 10:15 AM
Star -

- Impact sensors Resistance -

- 08-45-09-01 .4
- 19-85-25-02 .4
- 23-13-01-05 .5
- 23-13-09-03 .3
- 08-90-75-08 3.3
- 08-90-90-01 3.4
- 08-90-65-04 1.0
- 08-14-25-03 .3
- 08-14-25-04 .3

(Drivers Air Bag A/T?)
 clock spring
 LA fit seat Belt & turning loop adjuster
 Air Bag control module (ORC)
 Body wiring Harness
 Instrument panel wiring Harness
 Head lamp to dash wiring Harness
 Frnt Impact sensors

75.20

I hereby authorize the repair work to be done along with the necessary materials. You and/or your employees may operate the vehicle for the purpose of testing, inspection or delivery at my risk. An express mechanic's lien is acknowledged on vehicle to secure the amount of repairs thereto. You will not be held responsible for loss or damage to vehicle or articles left in vehicle in case of fire, theft, accident or any other cause beyond your control or for any delays caused by unavailability of parts or delays in parts shipments by the supplier or transporter.

PRELIMINARY ESTIMATE # _____

AUTHORIZED BY X

REVISED ESTIMATE (1)	DATE	TIME	BY
REVISED ESTIMATE (2)			
REVISED ESTIMATE (3)			

I HEREBY ACKNOWLEDGE THAT I WAS NOTIFIED & GAVE ORAL APPROVAL OF THE ABOVE REVISED ESTIMATES:

X

CSHMINCH-WZJIA R02

SHOP COPY

2364181

DAIMLERCHRYSLER MOTORS CORPORATION INVOICE

10050-A PLANT ZONE DEALER VEHICLE ID NO. INVOICE NO. INVOICE DT
TOLEDO NORTH 72 63826 1J4GL48K73W [REDACTED] 3-KJJ-65108670 12/06/02

SHIP TO: [REDACTED]
FAIRBANKS AK [REDACTED]

11/4/03
NK

IGN KEY M2307
TRK KEY 2307
ACC KEY 5390
2462-01-C306

SOLD TO: [REDACTED]
FAIRBANKS AK [REDACTED]

SHIPPING WT. 3805

PAID FOR BY: CHRYSLER FINANCIAL CORPORATION
XX CREDIT SALE CASH SALE

SAE HP 32.2
000-222222-75

BODY & EQUIP. DESCRIPTION FACTORY WHOLESALE PRICE

KJJH74	JEEP LIBERTY SPORT 4WD	17,908.00
PB7	Patriot Blue Pearl Coat	
MSDV	Seats - Cloth High-Back Bucket	NO CHARGE
AHM	Convenience Group I	167.00
DDD	Transmission - 5-Speed HD Manual	
EKG	Engine - 3.7L Power Tech V6	765.00
NHK	Engine Block Heater	36.00
RBK	Radio-AM/FM Compact Disc w/Chgr Ctrl	113.00
YDH	DaimlerChrysler Owner Loyalty Mail	20.00
2TA	Customer Preferred Package 2TA	
26A	Customer Preferred Package 26A	
3VC	Customer Preferred Discount	
E55	ALASKA - DAA	205.00
L55	ALASKA - PPA/EB-PF	210.00
461	DESTINATION CHARGE HB 60700	610.00

MDH # 120409
EP 18787

\$24,224.00

MSRP RETAIL TOTAL 20,830.00 TOTAL 20,034.00
ORIGINAL INVOICE

THIS VEHICLE IS MANUFACTURED TO MEET SPECIFIC UNITED STATES REQUIREMENTS. THIS VEHICLE IS NOT MANUFACTURED FOR SALE OR REGISTRATION OUTSIDE OF THE UNITED STATES.

cairnumber



CONFIDENTIAL - Prior Approval Required Before Duplicating

Preliminary Vehicle Investigation Report(PVIR)

CAIR# 10961678

YEAR	BRAND	VEHICLE IDENTIFICATION NUMBER		MO/DY-HR	ODOMETER	SERVICE DATE
2003	JEEP LIBERTY SPORT 4X4 SPORT UTILITY 4-DR	1J4GL48K73W		12-04 09	13	12/04/2002
NAME OF OWNER		ADDRESS/LOCATION		CITY		STATE
				FAIRBANKS		AK
ZIP	COLOR	MODEL	HOME PHONE		BUSINESS PHONE	
	Patriot Blue Pearl Coat	KJJ				
SELLING DEALER NAME		ZONE	DLR. CODE	CITY	STATE	
GENE'S CHRYSLER CENTER		71	63826	FAIRBANKS	AK	
INSPECTOR - NAME FIRST, LAST, MIDDLE			INSPECTOR'S COMPANY		INSPECTOR'S PHONE NO.	
David Vial B			EAA		253-851-3991	
DAMAGE ESTIMATE				REPAIR ESTIMATE		
<input checked="" type="radio"/> MINOR <input type="radio"/> MODERATE <input type="radio"/> TOTAL LOSS				\$ 2000.00		

INTERVIEW

INTERVIEW WITH: DRIVER OWNER OTHER DRIVER/OWNER

NAME: LAST, FIRST, MIDDLE Monsey Rich

INTERVIEW DATE: **02/20/2003** DATE OF INCIDENT: **02/13/2003** TIME OF INCIDENT: **08:00** AM PM INSPECTION DATE: **02/20/2003**

1. DRIVER'S DESCRIPTION OF EVENT: **Dealerships shop foreman statement was the vehicle was moved off the sales lot so snow could be removed. The engine was left idling with heater switch on high speed and temperature setting at the highest level. The vehicle was apparently left idling as stated several hours - exact amount of time is not known. When returning to the vehicle at 4 hours the airbag had not deployed however when returning to the vehicle at the end of the day the driver side airbag had deployed.**

Insurance Company **N/A**

Name: Personal Injury: Were there Personal Injuries? Yes No

If Yes, complete section "B"

Any Indicator/ Warning Lights on Prior? Yes No

If Yes, What light:

IMPORTANT: SHOW THIS REPORT TO NO ONE & ONLY STATE FACTS (DRAW NO CONCLUSIONS)

Help Key

PART A- GENERAL

REQUIRED PHOTOGRAPHS:

- ALL FOUR SIDE VIEWS
- IF CRASH DAMAGED:**
- PERSPECTIVE FROM EVERY CORNER OF VEHICLE DOWN BOTH ORIGINAL LATERAL SIGHT LINES(8 TOTAL)
- ANY RECENT VEHICLE SERVICE

YES NO

UNKNOWN

IF YES, ENCLOSE COPIES OF REPAIR ORDERS

INFORMATION:

- POLICE/AGENCY REPORT #:

N/A

- ALL REPORTS/PHOTOS BY OTHERS

- ADDRESS OF INSPECTION
 Address **3400 Cushman St.**
 1
 Address
 2
 City **Fairbanks**
 State **AK**
 Zip **99701**
 PHONE

- EVIDENCE OF TAMPERING OR PRIOR DISASSEMBLY

YES NO

- IF YES, DESCRIBE AND PHOTOGRAPH

PART B - EXTERIOR/INTERIOR VEHICLE DAMAGE

REQUIRED PHOTOGRAPHS: N/A

- WINDSHIELD
- ALL AREAS OF DAMAGE MARKINGS ON INTERIOR AND EXTERIOR
- CLOSE UPS OF STAINS, SKIN, HAIR, CLOTH
- EXTERIOR AND INTERIOR DAMAGE INCLUDING UNDERCARRIAGE

INFORMATION:

- DESCRIBE ANY INJURIES TO DRIVER AND/OR OTHER OCCUPANTS
- SEE SEAT BELT/SEATS SECTION IF APPLICABLE

Next

cairnumber



PART C - AIRBAG(S)

REQUIRED PHOTOGRAPHS

- STEERING WHEEL
- AIRBAG(S)
- KNEE BLOCKERS
- ALL POSSIBLE LOCATIONS OF CONTACT

AECM INFORMATION

- SOFTWARE VERSION:

N/A

- SERIAL NUMBER :

TRFME3292E0212

- PART NUMBER :

P56010501AI

- DOES AIRBAG WARNING LIGHT CYCLE ON?

YES NO N/A

- ARE WARNING LABELS PRESENT (PHOTO)

YES NO N/A

- RECORD LABEL PART NUMBER

N/A

COMPLETE PART D

- PHOTOGRAPH REQUIRED FOR DRB SCREENS & RECORD FAULTS
- WERE THERE DRB READINGS TAKEN?

YES NO IF NO, EXPLAIN

- RECORD ACTIVE DTC'S EXACTLY AS APPEAR :	MIN	COUNT
No Communication with ABM	0	0
- RECORD STORED DTC'S (MINUTES/COUNTS) :	MIN	COUNT
No DTC's found	0	0

- WAS AIRBAG DEPLOYED?

DRIVER YES NO

IF NO, EXPLAIN

PASSENGER YES NO

IF NO, EXPLAIN

No Deployment

SIDE AIRBAG YES NO N/A

IF NO, EXPLAIN

Not equipt.

- WHICH SIDE DEPLOYED?

LEFT RIGHT N/A BOTH

- TYPE OF SIDE AIRBAG

SEAT CURTAIN N/A

- TYPE OF STEERING WHEEL

TILT STANDARD

- ANY DAMAGE TO STEERING WHEEL

YES NO

IF YES, EXPLAIN

DO NOT ERASE DRB READINGS

IS VEHICLE EQUIPPED WITH PASSENGER AIRBAG DEFAULT SWITCH?

YES NO

IF YES,

NOTE POSITION OF PASSENGER A/B SWITCH

ON OFF N/A

- EVIDENCE OF TAMPERING OR DISASSEMBLY?

YES NO N/A

IF YES, EXPLAIN

CHECK ENTIRE UNDERBODY FOR HIDDEN DAMAGE INCLUDING FRONT AND REAR SUSPENSION COMPONENTS

- UNDERBODY DAMAGED?

YES NO

IF YES, EXPLAIN

PHOTOGRAPH REQUIRED

PART - D SEATS/SHOULDER BELTS NOT APPLICABLE

PART - E TRANSMISSION NOT APPLICABLE

Previous

Next

PART - F UNINTENDED ACCELERATION NOT APPLICABLE

PART - G BRAKES NOT APPLICABLE

PART - H STEERING/SUSPENSION/TIRES NOT APPLICABLE

PART - I AXLE/DIFFERENTIAL NOT APPLICABLE

PART J - ADDITIONAL COMMENTS (DO NOT DRAW ANY CONCLUSIONS)

The vehicle was inspected at [REDACTED] Fairbanks, AK, on 02/20/2003. Facts: This vehicle driver side airbag had deployed. The driver side seat belt tensioner had also deployed. The following tests were performed. · The DRB III scan tool was used to for scan stored DTC's, photo "DRB III view of communication with all modules" will show communication with applicable modules. Please note there was no communication with the airbag module. · The only communication was with BCM, MTC, and RBK. · The airbag MIL with ignition key in run position was steady red and did not cycle off. · The center shift council was removed to expose ACM. The ACM yellow connector was in place and locked. Serial number of the module is P56010501AI. · The dummy connector was placed on ACM wire bulk connector. The following tests reveal: #8 cavity -driver side squib – low – 5.7 ohms and not steady. #5 cavity – driver side squib – high – 3.3 ohms and steady. #6 cavity – driver seat belt tensioner – 1290 ohms and not steady. · The driver doorsill molding was removed. The wire harness to seat belt was inspected for possible damage – none found. The wire harness under dash panel was inspected for damage and none was found. · The 2 - 10 ampere airbag fuses were in place and tested for continuity and tested for open. The bridges were intact. · The wiring schematics were reviewed with applicable service manual. All wire going to ACM bulkhead connector was in proper order. · The ACM module back cover was removed. The processor board was checked for any discolor, burn spots. None discovered. · Photos will show no damage from impact in the frontal areas of the vehicle. Summary: Dealer personnel discovered deployment after the vehicle had been idling for lengthily period of time (4 to 8 hours) with heater controls on high speed and high temperature settings. Inside cabin temperatures were not determined when the airbag deployed.

Previous

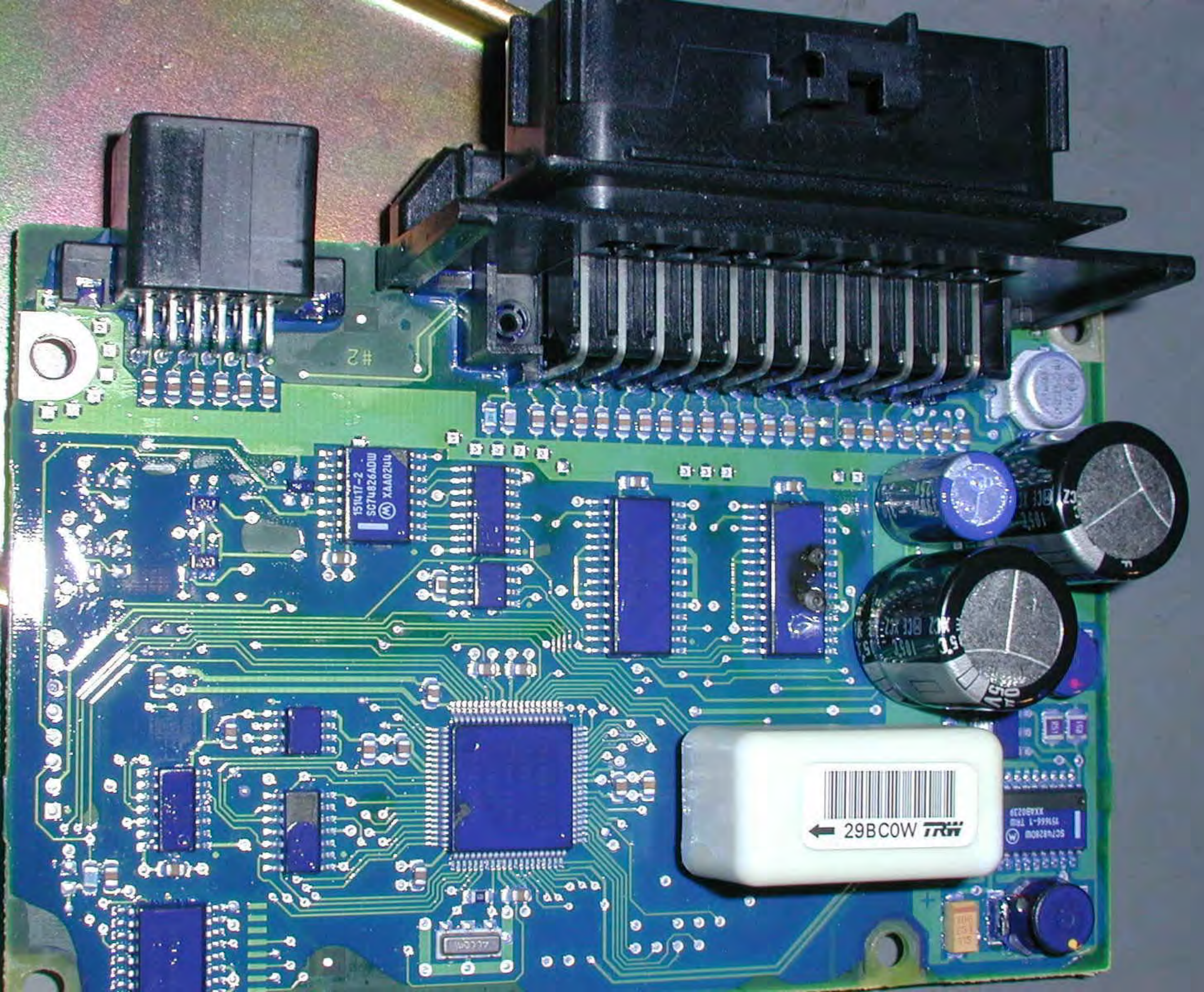

#2

1514T-2
SC74826ADW
XAA0244

← 29BC0W TRW

SC74826ADW
M08281205
M01 1-99945

SC74826ADW
M01 1-99945

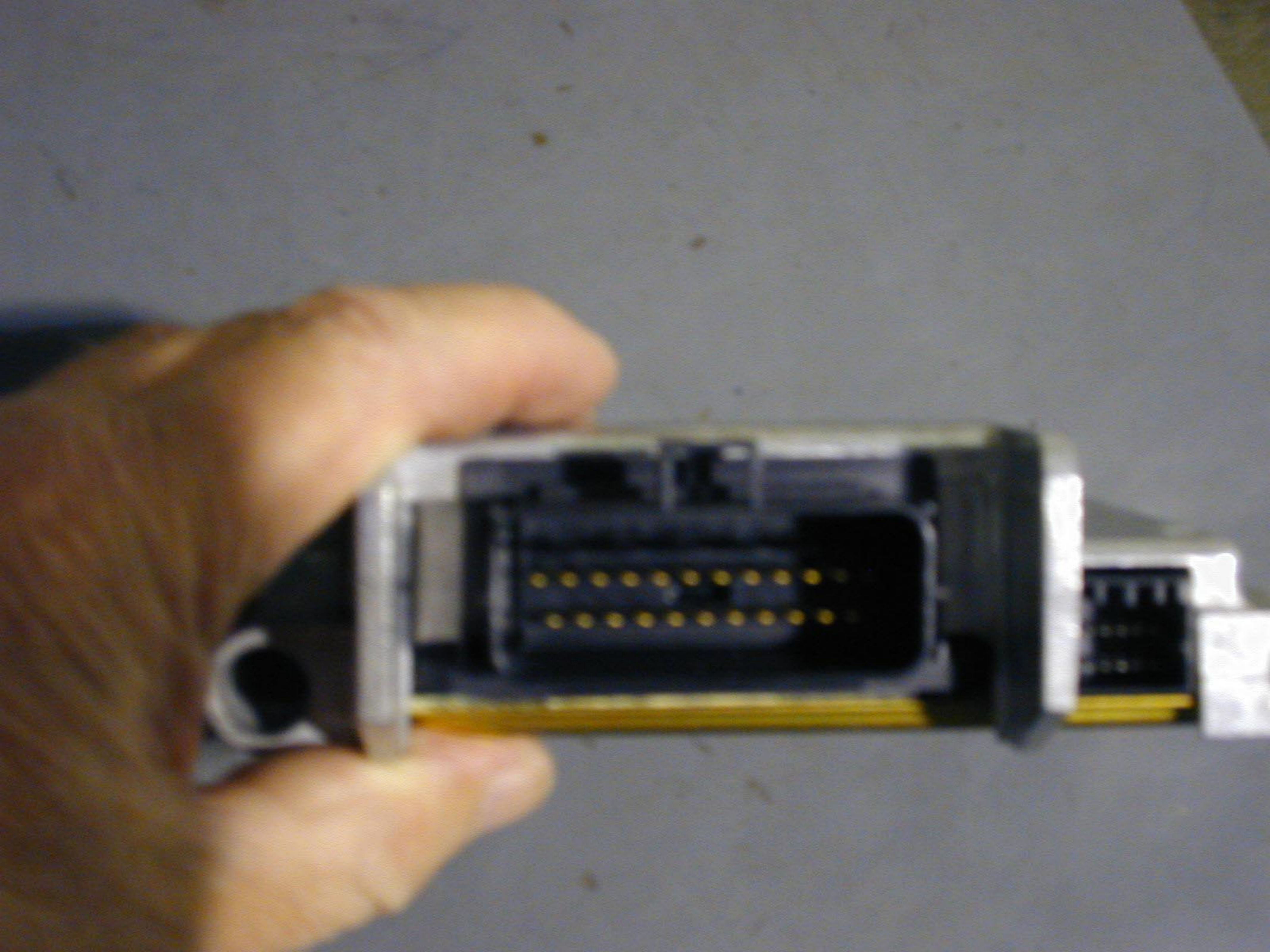

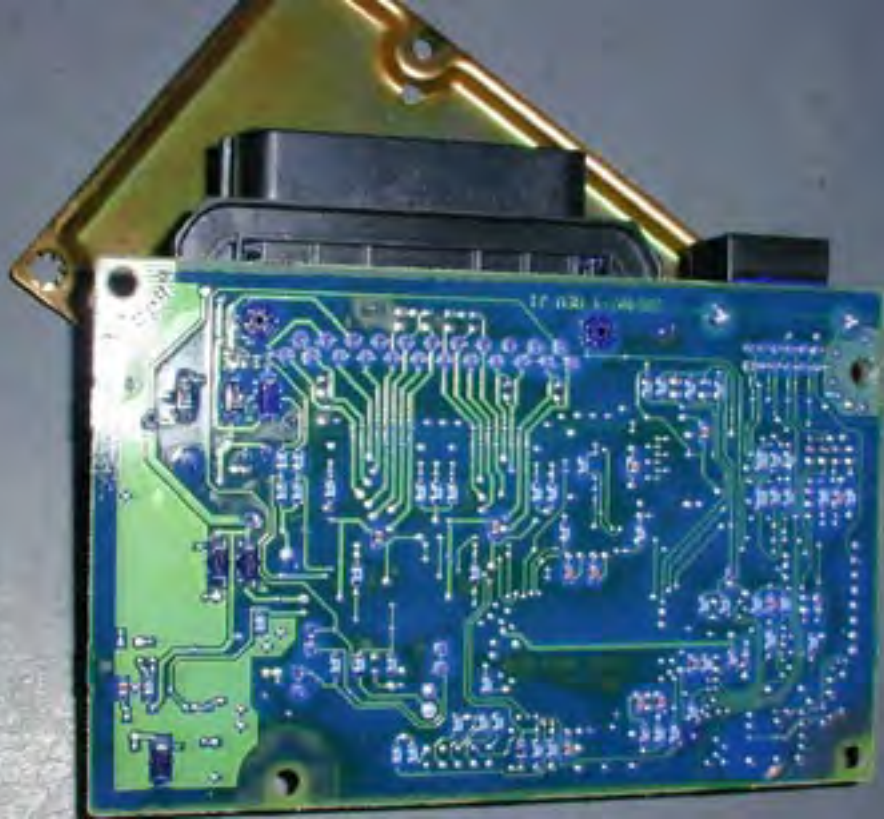

UNIVERSITY OF THE SOUTH ALABAMA

UNIVERSITY OF THE SOUTH ALABAMA

UNIVERSITY OF THE SOUTH ALABAMA

UNIVERSITY OF THE SOUTH ALABAMA

UNIVERSITY OF THE SOUTH ALABAMA

UNIVERSITY OF THE SOUTH ALABAMA

UNIVERSITY OF THE SOUTH ALABAMA

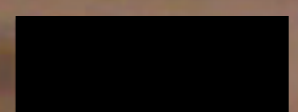

Vehicle Scan Tool

1. 3.7 3.4.7 JTEC+ 99
2. BCM_KJ
3. * MIC_KJ
4. RBK Audio

Page 1 of 1

PCM

Item 41 of 41







SAFARI
SAVINGS

WARNING
DO NOT
SMOKE
OR
DRINK
ALCOHOL
WHILE
DRIVING





CHRYSLER PIN P5601060147



WARNING: REFER TO SERVICE MANUAL BEFORE SERVICE.

IMPROPER SERVICING CAN RESULT IN AIR BAG SYSTEM

FAILURE AND POSSIBLE DRIVER AND/OR PASSENGER INJURY.

CHRYSLER SN TRFME329E3E00112

TRFME329E3E00112

CHRYSLER SN TRFME329E3E00112

TRFME329E3E00112

TRFME329E3E00112

TRFME329E3E00112

TRFME329E3E00112

TRFME329E3E00112

TRFME329E3E00112

TRFME329E3E00112

TRFME329E3E00112

TRFME329E3E00112

TRFME329E3E00112

TRFME329E3E00112

TRFME329E3E00112

TRFME329E3E00112

MFD BY

DAIMLERCHRYSLER
CORPORATIONDATE OF MFR
12-02GVWR
2541 KG(05600 LB)

GVWR FRONT

1248 KG(2750 LB)

WITH TIRES

P215/75R16

RIMS AT

16X7

COLD

227 KPA(33 PSI)

GVWR REAR

1429 KG(3150 LB)

WITH TIRES

R215/75R16

RIMS AT

16X7

COLD

227 KPA(33 PSI)

THIS VEHICLE CONFORMS TO ALL APPLICABLE FEDERAL MOTOR VEHICLE SAFETY AND THEFT
PREVENTION STANDARDS IN EFFECT ON THE DATE OF MANUFACTURE SHOWN ABOVE.

VIN: 1J4GL48K73W

TYPE:

MPV

SINGLE X DUAL



RDM:

120409 776AB

PNT:PB7

VEHICLE MADE IN U.S.A.

TQM:H50V

4648503





248 CDA 27W







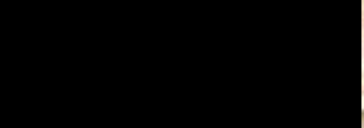

PLEASE PLUG IN
ONLY WHEN
TEMPERATURE IS
BELOW -10
WHEN YOU COME
TO WORK
THANKS!

SAFETY
SAVINGS

WARNING
SEE USER MANUAL
FOR MORE INFORMATION





DEALER MUST REMOVE PROTECTIVE COVER





From: [REDACTED]
To: customerassist@daimlerchrysler.com
Date: Wed May 21 18:46:23 EDT 2003
Subject: DaimlerChrysler Customer Assistance
Form Selected:

Category: US Customer Service
Brief Description:

have a 2003 Liberty, air bag light will not turn off. will not be able to get to dealer until Saturday or Tuesday. have 2 fairly long trips for tomorrow Thursday and Friday. will I expose anyone to any danger driving with light on?

Comments:

Sender Information:

Title:
First Name: [REDACTED]
Middle Initial:
Last Name: [REDACTED]

From: customerassist@daimlerchrysler.com
To: [REDACTED]
Date: Thu May 22 10:16:47 EDT 2003
Subject: Re: DaimlerChrysler Customer Assistance
Dear Joseph:

Thank you for contacting DaimlerChrysler regarding your '03 Jeep Liberty.

The air bag light comes on when it detects a malfunction in the system. If the air bag light is on there is the potential of the air bags not working as deploying as designed in the event of an accident or the possibility of them deploying without warning.

We would recommend you have the vehicle inspected by a dealership to ensure the safety of you and your passengers.

Thanks again for contacting us.

I see by your records that you are still eligible to purchase a DaimlerChrysler Service Contract.

If you want the best in extended coverage for your vehicle, consider a DaimlerChrysler Service Contract. DaimlerChrysler Service Contracts have a wide variety of plans to suit your needs. Whether it's a roadside assistance, trip interruption or just the security of knowing your vehicle is covered after the manufacturer's warranty, there is a DaimlerChrysler Service Contract that is right for you.

All Chrysler, Dodge and Jeep vehicles are eligible within 4 years or 48,000 miles of purchase. Your DaimlerChrysler Dealer can give you full details on plans and pricing. You can also visit our website at <http://www.servicecontracts.chrysler.com> for more information, or click on the link below to request a brochure.

www.servicecontracts.chrysler.com/getabrochure.html.

If you have further questions or you would like a quote, please contact DaimlerChrysler Service Contracts Enrollment Headquarters directly at 1-800-442-2666.

NOTE: Please do not use the 'Reply' function of your email system. If you have a need to respond to this message, please visit us at our reply form (link provided below). Our system is NOT able to accept any emails at this address.

For any future communications related to this email, please refer to the following information:

REFERENCE NUMBER: [REDACTED]

REPLY LINK:

http://www.chrysler.com/wccsapp/wccs/brand_forms/us/reply.jsp?trk_ID=KMM10449 [REDACTED]

Sincerely,

Michael Fairo
Senior Staff Representative
DaimlerChrysler Customer Assistance Center

Original Message Follows:

Form Selected:

Category: US Customer Service

Brief Description:

have a 2003 Liberty, air bag light will not turn off. will not be able to get to dealer until Saturday or Tuesday. have 2 fairly long trips for tomorrow Thursday and Friday. will I expose anyone to any danger driving with light on?

Comments:

Sender Information:

Title:

First Name:

Middle Initial:

Last Name:











Jeep

Grand Cherokee
4x4

3.7L



Jeep

David O'Neal
11111 11111 11111 11111

ERTY sport

A close-up photograph of a dark-colored car door. The door features a silver, horizontal handle with a circular lock mechanism on its right side. Below the handle, the text "ERTY sport" is printed in a light, sans-serif font. A silver trim piece runs horizontally along the bottom edge of the door. The car's body is highly reflective, showing bright highlights from an overhead light source. Through the window, the interior of the car is partially visible, including the steering wheel and dashboard.



LIBERTY

4754

Jeep





LIBERTY sport

RE







cairnumber : [REDACTED]**CONFIDENTIAL - Prior Approval Required Before Duplicating****Preliminary Vehicle Investigation Report(PVIR)**

CAIR# 11960954

YEAR	BRAND	VEHICLE IDENTIFICATION NUMBER		MO/DY-HR	ODOMETER	SERVICE DATE
2002	JEEP LIBERTY SPORT 4X4 SPORT UTILITY 4-DR	1J4GL48K72W	[REDACTED]	01-08 10	28307	09/03/2002
NAME OF OWNER		ADDRESS/LOCATION		CITY	STATE	COUNTRY
[REDACTED]		[REDACTED]		MORRISVILLE	NC	USA
ZIP	COLOR	MODEL	HOME PHONE		BUSINESS PHONE	
[REDACTED]	Black Clear Coat	KJJ	[REDACTED]			
SELLING DEALER NAME	BUSINESS CENTER	DLR. CODE	CITY	STATE	COUNTRY	
DAVID O'NEAL INC	66	67779	RALEIGH	NC	USA	
INSPECTOR - NAME FIRST, LAST, MIDDLE		INSPECTOR'S COMPANY		INSPECTOR'S PHONE NO.		
Herman Montgomery B				704-488-2579		
DAMAGE ESTIMATE				REPAIR ESTIMATE		
<input checked="" type="radio"/> MINOR <input type="radio"/> MODERATE <input type="radio"/> TOTAL LOSS				\$ 2500.00		

INTERVIEW

INTERVIEW WITH:

 DRIVER OWNER OTHER DRIVER/OWNERNAME: LAST, FIRST, MIDDLE [REDACTED]

INTERVIEW DATE:

01/18/2004

DATE OF INCIDENT:

01/11/2004

TIME OF INCIDENT

02:00 AM PM

INSPECTION DATE:

01/20/2004

1. DRIVER'S

DESCRIPTION OF EVENT:

Mr. [REDACTED] stated that he was traveling down the road, coming up to a traffic light that was green. As he made a right turn at about 10 MPH, the drivers side airbag went off. He stopped the vehicle and collected his thoughts. Since he was out of town he packed the airbag back in place and drove home.

Insurance

Company

State Farm

Name:

Personal Injury:

Were there

 Yes No

If Yes, complete section "B"

Personal

Injuries?

Any Indicator/

Warning Lights

 Yes No

If Yes, What light:

on Prior?

IMPORTANT: SHOW THIS REPORT TO NO ONE & ONLY STATE FACTS (DRAW NO CONCLUSIONS)

Help Key

PART A- GENERAL

REQUIRED PHOTOGRAPHS:

- ALL FOUR SIDE VIEWS
- IF CRASH DAMAGED:**
- PERSPECTIVE FROM EVERY CORNER OF VEHICLE DOWN BOTH ORIGINAL LATERAL SIGHT LINES(8 TOTAL)
- ANY RECENT VEHICLE SERVICE

YES NO

UNKNOWN

IF YES, ENCLOSE COPIES OF REPAIR ORDERS

INFORMATION:

POLICE/AGENCY REPORT #:

ALL REPORTS/PHOTOS BY OTHERS

- ADDRESS OF INSPECTION

Address **David O'Neal Chrysler**

1

Address **5500 Capital Blvd**

2

City **Raleigh**

State **NC**

Zip **27619**

PHONE

- EVIDENCE OF TAMPERING OR PRIOR DISASSEMBLY

YES NO

- IF YES, DESCRIBE AND PHOTOGRAPH

PART B - EXTERIOR/INTERIOR VEHICLE DAMAGE

REQUIRED PHOTOGRAPHS: **There is no physical damage to the vehicle. There is no personal injuries. The drivers side airbag deployed.**

- WINDSHIELD
- ALL AREAS OF DAMAGE MARKINGS ON INTERIOR AND EXTERIOR
- CLOSE UPS OF STAINS, SKIN, HAIR, CLOTH
- EXTERIOR AND INTERIOR DAMAGE INCLUDING UNDERCARRIAGE

INFORMATION:

- DESCRIBE ANY INJURIES TO DRIVER AND/OR OTHER OCCUPANTS
 - SEE SEAT BELT/SEATS SECTION IF APPLICABLE
-
-

Next

cairnumber : [REDACTED]

PART C - AIRBAG(S)

REQUIRED PHOTOGRAPHS

- STEERING WHEEL
- AIRBAG(S)
- KNEE BLOCKERS
- ALL POSSIBLE LOCATIONS OF CONTACT

AECM INFORMATION

- SOFTWARE VERSION:

- SERIAL NUMBER :

1J4GL48K7 [REDACTED]

- PART NUMBER :

- DOES AIRBAG WARNING LIGHT CYCLE ON?

- YES NO N/A

- ARE WARNING LABELS PRESENT (PHOTO)

- YES NO N/A

- RECORD LABEL PART NUMBER

COMPLETE PART D

- PHOTOGRAPH REQUIRED FOR DRB SCREENS & RECORD FAULTS
- WERE THERE DRB READINGS TAKEN?

- YES NO IF NO, EXPLAIN

The code read,unable to ID Module.

- RECORD ACTIVE DTC'S EXACTLY AS APPEAR :	MIN	COUNT
Unable to ID Module		
- RECORD STORED DTC'S (MINUTES/COUNTS) :	MIN	COUNT

- WAS AIRBAG DEPLOYED?

- DRIVER YES NO

IF NO, EXPLAIN

- PASSENGER YES NO

IF NO, EXPLAIN

Did not deploy

- SIDE AIRBAG YES NO N/A

IF NO, EXPLAIN

- WHICH SIDE DEPLOYED?

- LEFT RIGHT N/A

BOTH

- TYPE OF SIDE AIRBAG

- SEAT CURTAIN N/A

- TYPE OF STEERING WHEEL

- TILT STANDARD

- ANY DAMAGE TO STEERING WHEEL

- YES NO
- IF YES, EXPLAIN

DO NOT ERASE DRB READINGS

IS VEHICLE EQUIPPED WITH PASSENGER AIRBAG DEFAULT SWITCH?

- YES NO

IF YES,

NOTE POSITION OF PASSENGER A/B SWITCH

- ON OFF N/A

- EVIDENCE OF TAMPERING OR DISASSEMBLY?

- YES NO N/A

IF YES, EXPLAIN

CHECK ENTIRE UNDERBODY FOR HIDDEN DAMAGE INCLUDING FRONT AND REAR SUSPENSION COMPONENTS

- UNDERBODY DAMAGED?

- YES NO
- IF YES, EXPLAIN

PHOTOGRAPH REQUIRED

PART D - SEATS/SHOULDER BELTS

REQUIRED PHOTOGRAPHS:

- OVERALL SEAT BELTS I/B & O/B
- CLOSE UP OF ANY IRREGULARITIES
- LATCHPLATE WEAR
- CLOSE UP D-RING TO SHOW LOADING
- OVERALL OF SEAT
- CLOSE UP OF DAMAGE
- RECORD DTC'S:

INFORMATION:

- LOCATE SEAT BELT LABELS AND RECORD ALL INFORMATION (SOME LABELS ARE SEWN TO WEBBING, OTHER LABELS ARE ON THE RETRACTOR FRAME: INBOARD SEAT BELT LABELS ARE NEAR THE FLOOR): **left front-TD049,Right front-T0049,Left rear-TC217,Right rear-TC226.**

- RECORD ALL INFORMATION STAMPED ON LATCHPLATE

- PRETENSION DEPLOYED?

- YES NO UNKNOWN

- EXISTING LOCATION OF RECLINER - DESCRIBE THE LOCATION AND PICTURE OF SEAT BACK WITH B PILLOR AS REFERENCE AND INCLINOMETER READING

EXISTING LOCATION OF HEAD RESTRAINT (MEASURE GAP UNDER HEAD RESTRAINT):

IF ALLOWED. FUNCTION BELTS TO INSURE THEY **FUNCTION PROPERLY**

NOTE RESULTS

- DOES THE BUCKLE LATCH?

- YES NO

IF NO, EXPLAIN

- DO THEY RELEASE?

- YES NO

IF NO, EXPLAIN

- DO THEY RETRACT?

- YES NO

IF NO, EXPLAIN

- ANY LOOSENESS OR BROKEN PARTS

- YES NO

IF YES, EXPLAIN?

- CHECK FOR SEAT RETAINING BOLTS

- NORMAL

BROKEN

LOOSE

MISSING

- NOTE AND RECORD APPROX. SEAT TRACK OVERLAP

PART - E TRANSMISSION NOT APPLICABLE

[Previous](#)

[Next](#)

PART - F UNINTENDED ACCELERATION NOT APPLICABLE

PART - G BRAKES NOT APPLICABLE

PART - H STEERING/SUSPENSION/TIRES NOT APPLICABLE

PART - I AXLE/DIFFERENTIAL NOT APPLICABLE

 PART J - ADDITIONAL COMMENTS (DO NOT DRAW ANY CONCLUSIONS)

The spare tire on the vehicle had a four inch cut in it but the owner states it did not come off the front of the vehicle.I inspected the vehicle completely and could find no physical damage.The front wheels were removed and no damage to the brakes.

Previous



9989

Jeep









Jeep

3.7L

WRANGLER SR-B
GOODYEAR







MFD BY DAIMLERCHRYSLER
CORPORATION

DATE OF MFR
10-01

GVWR
2541 KG (05600 LB)

GVWR FRONT
1730 KG (2600 LB) WITH TIRES
P215/75SR16

RIMS AT
16X7

COLD

GVWR REAR
1429 KG (3150 LB) WITH TIRES
P215/75SR16

RIMS AT
16X7

227 KPA (33 PSI)

COLD

227 KPA (33 PSI)

THIS VEHICLE CONFORMS TO ALL APPLICABLE FEDERAL MOTOR VEHICLE SAFETY AND THEFT
PREVENTION STANDARDS IN EFFECT ON THE DATE OF MANUFACTURE SHOWN ABOVE.

VIN: 1J4GL48K52W [REDACTED]

TYPE: MPV

SINGLE X DUAL



MDH: 101602 387AA PNT:PR4

VEHICLE MADE IN U.S.A. TRM:MSDU 4648503















WARNING
DEATH OR SERIOUS INJURY CAN OCCUR



989



WARNING



BEWAKUKAN KESELAMATAN
MELAKUKAKAN PERKILAH

WARNING



BEWAKUKAN KESELAMATAN
MELAKUKAKAN PERKILAH

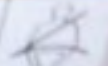

990





060702















All-Terrain T/A

BFGoodrich



BFGoodrich

All-Terrain T/A







12V 45Ah
AGM 5500000000

















CHRYSLER P/N P56010501AE

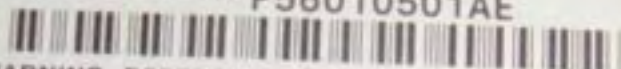

WARNING. REFER TO SERVICE MANUAL BEFORE SERVICING.
IMPROPER SERVICING CAN RESULT IN AIR BAG SYSTEM
FAILURE AND POSSIBLE DRIVER AND/OR PASSENGER INJURY.

CHRYSLER S/N TSFME2811A7513

SUPPLIER CODE

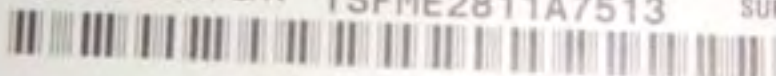

39754C

From: [REDACTED]
To: customerassist@daimlerchrysler.com
Date: Tue Jan 20 13:12:58 EST 2004
Subject: DaimlerChrysler Customer Assistance
Form Selected:

Category: US Customer Service
Brief Description:

Airbag deployment in parked vehicle
Comments:

I parked the vehicle at the side of the road - got out to talk with a neighbor - we heard a bang and both airbags had deployed . Vehicle was stationary engine was idleing.

Sender Information:

Title [REDACTED]
First Name: [REDACTED]
Middle Initial: [REDACTED]
Last Name: [REDACTED]

cairnumber :11991929

CONFIDENTIAL - Prior Approval Required Before Duplicating**Preliminary Vehicle Investigation Report(PVIR)**

CAIR# [REDACTED]

YEAR	BRAND	VEHICLE IDENTIFICATION NUMBER		MO/DY-HR	ODOMETER	SERVICE DATE
2002	JEEP LIBERTY SPORT 4X4 SPORT UTILITY 4-DR	1J4GL48K52W [REDACTED]		10-16 02	60702	03/28/2002
NAME OF OWNER		ADDRESS/LOCATION		CITY	STATE	COUNTRY
[REDACTED]		[REDACTED]		AUBERRY	CA	USA
ZIP	COLOR	MODEL	HOME PHONE		BUSINESS PHONE	
[REDACTED]	Flame Red Clear Coat	KJJ	[REDACTED]		[REDACTED]	
SELLING DEALER NAME		BUSINESS CENTER	DLR. CODE	CITY	STATE	COUNTRY
SURROZ DODGE-CHRY-JEEP		71	43921	VISALIA	CA	USA
INSPECTOR - NAME FIRST, LAST, MIDDLE			INSPECTOR'S COMPANY		INSPECTOR'S PHONE NO.	
Hank Machado			SPX-E.A.A.		408-778-9555	
DAMAGE ESTIMATE				REPAIR ESTIMATE		
<input type="radio"/> MINOR <input checked="" type="radio"/> MODERATE <input type="radio"/> TOTAL LOSS				\$ 2500.00		

INTERVIEW

INTERVIEW WITH:

 DRIVER
 OWNER
 OTHER
 DRIVER/OWNER

NAME: LAST, FIRST, MIDDLE [REDACTED]

INTERVIEW DATE:

DATE OF INCIDENT:

TIME OF INCIDENT

INSPECTION DATE:

01/22/2004**01/18/2004****00:01** AM PM**01/22/2004**

1. DRIVER'S DESCRIPTION OF EVENT: **Driver advises he had parked the vehicle and left the engine running. He got out of the vehicle and heard the airbags deploy.**

Insurance

Company

Farmers

Name:

Personal Injury:

Were there

Personal

 Yes No

If Yes, complete section "B"

Injuries?

Any Indicator/

Warning Lights

 Yes No

If Yes, What light:

on Prior?

IMPORTANT: SHOW THIS REPORT TO NO ONE & ONLY STATE FACTS (DRAW NO CONCLUSIONS)

PART A- GENERAL

REQUIRED PHOTOGRAPHS:

- ALL FOUR SIDE VIEWS
- IF CRASH DAMAGED:**
- PERSPECTIVE FROM EVERY CORNER OF VEHICLE DOWN BOTH ORIGINAL LATERAL SIGHT LINES(8 TOTAL)
- ANY RECENT VEHICLE SERVICE

YES NO

UNKNOWN

IF YES, ENCLOSE COPIES OF REPAIR ORDERS

INFORMATION:

POLICE/AGENCY REPORT #:

None

ALL REPORTS/PHOTOS BY OTHERS

- ADDRESS OF INSPECTION

Address **Fresno C-J**

1

Address **4880 Blackstone**

2

City **Fresno**

State **CA**

Zip **93726**

PHONE

- EVIDENCE OF TAMPERING OR PRIOR DISASSEMBLY

YES NO

- IF YES, DESCRIBE AND PHOTOGRAPH

PART B - EXTERIOR/INTERIOR VEHICLE DAMAGE

REQUIRED PHOTOGRAPHS:

- WINDSHIELD
- ALL AREAS OF DAMAGE MARKINGS ON INTERIOR AND EXTERIOR
- CLOSE UPS OF STAINS, SKIN, HAIR, CLOTH
- EXTERIOR AND INTERIOR DAMAGE INCLUDING UNDERCARRIAGE

INFORMATION:

- DESCRIBE ANY INJURIES TO DRIVER AND/OR OTHER OCCUPANTS
- SEE SEAT BELT/SEATS SECTION IF APPLICABLE

Windshield is cracked from rock chips. The vehicle was not occupied when airbags deployed. There were no injuries involved with this incident.

Next

cairnumber : XXXXXXXXXX

PART C - AIRBAG(S)

REQUIRED PHOTOGRAPHS

- STEERING WHEEL
- AIRBAG(S)
- KNEE BLOCKERS
- ALL POSSIBLE LOCATIONS OF CONTACT

AECM INFORMATION

- SOFTWARE VERSION:

NO RESPONSE

- SERIAL NUMBER :

TSFME2811A7513

- PART NUMBER :

P56010501AE

- DOES AIRBAG WARNING LIGHT CYCLE ON?

YES NO N/A

- ARE WARNING LABELS PRESENT (PHOTO)

YES NO N/A

- RECORD LABEL PART NUMBER

NONE

COMPLETE PART D

- PHOTOGRAPH REQUIRED FOR DRB SCREENS & RECORD FAULTS
 - WERE THERE DRB READINGS TAKEN?

YES NO IF NO, EXPLAIN

NO RESPONSE FROM SRS SYSTEM

- RECORD ACTIVE DTC'S EXACTLY AS APPEAR :	MIN	COUNT
DRB III HAS NO RESPONSE FROM SRS CONTROLLER		
- RECORD STORED DTC'S (MINUTES/COUNTS) :	MIN	COUNT
UNABLE TO OBTAIN ANY INFO WITH DRB III FROM CONTROLLER		

- WAS AIRBAG DEPLOYED?

DRIVER YES NO

IF NO, EXPLAIN

PASSENGER YES NO

IF NO, EXPLAIN

SIDE AIRBAG YES NO N/A

IF NO, EXPLAIN

- WHICH SIDE DEPLOYED?

LEFT RIGHT N/A

BOTH

- TYPE OF SIDE AIRBAG

SEAT CURTAIN N/A

- TYPE OF STEERING WHEEL

TILT STANDARD

- ANY DAMAGE TO STEERING WHEEL

YES NO
 IF YES, EXPLAIN

DO NOT ERASE DRB READINGS

IS VEHICLE EQUIPPED WITH PASSENGER AIRBAG DEFAULT SWITCH?

YES NO

IF YES,

NOTE POSITION OF PASSENGER A/B SWITCH

ON OFF N/A

- EVIDENCE OF TAMPERING OR DISASSEMBLY?

YES NO N/A

IF YES, EXPLAIN

CHECK ENTIRE UNDERBODY FOR HIDDEN DAMAGE INCLUDING FRONT AND REAR SUSPENSION COMPONENTS

- UNDERBODY DAMAGED?

YES NO
 IF YES, EXPLAIN

PHOTOGRAPH REQUIRED

PART D - SEATS/SHOULDER BELTS

REQUIRED

PHOTOGRAPHS:

- OVERALL SEAT BELTS I/B & O/B
- CLOSE UP OF ANY IRREGULARITIES
- LATCHPLATE WEAR
- CLOSE UP D-RING TO SHOW LOADING
- OVERALL OF SEAT
- CLOSE UP OF DAMAGE
- RECORD DTC'S:

INFORMATION:

- LOCATE SEAT BELT LABELS AND RECORD ALL INFORMATION (SOME LABELS ARE SEWN TO WEBBING, OTHER LABELS ARE ON THE RETRACTOR FRAME: INBOARD SEAT BELT LABELS ARE NEAR THE FLOOR):

VEHICLE NOT OCCUPIED

- RECORD ALL INFORMATION STAMPED ON LATCHPLATE

VEHICLE NOT OCCUPIED

- PRETENSION DEPLOYED?

YES NO UNKNOWN

- EXISTING LOCATION OF RECLINER - DESCRIBE THE LOCATION AND PICTURE OF SEAT BACK WITH B PILLOR AS REFERENCE AND INCLINOMETER READING

VEHICLE NOT OCCUPIED

EXISTING LOCATION OF HEAD RESTRAINT (MEASURE GAP UNDER HEAD RESTRAINT):

IF ALLOWED. FUNCTION BELTS TO INSURE THEY **FUNCTION PROPERLY**

NOTE RESULTS

- DOES THE BUCKLE LATCH?

YES NO

IF NO, EXPLAIN

- DO THEY RELEASE?

YES NO

IF NO, EXPLAIN

- DO THEY RETRACT?

YES NO

IF NO, EXPLAIN

- ANY LOOSENESS OR BROKEN PARTS

YES NO

IF YES, EXPLAIN?

- CHECK FOR SEAT RETAINING BOLTS

NORMAL

BROKEN

LOOSE

MISSING

MISSING
NOTE AND RECORD APPROX. SEAT TRACK
OVERLAP
VEHICLE NOT OCCUPIED

PART - E TRANSMISSION NOT APPLICABLE

Previous

Next

PART - F UNINTENDED ACCELERATION NOT APPLICABLE

PART - G BRAKES NOT APPLICABLE

PART - H STEERING/SUSPENSION/TIRES NOT APPLICABLE

PART - I AXLE/DIFFERENTIAL NOT APPLICABLE

PART J - ADDITIONAL COMMENTS (DO NOT DRAW ANY CONCLUSIONS)

THE DRB III IS UNABLE TO COMMUNICATE WITH THE AIRBAG MODULE. AIRBAGS DEPLOYED WHEN THE VEHICLE WAS PARKED WITH THE ENGINE RUNNING.THERE WERE NO OCCUPANTS IN THE VEHICLE AT THE TIME. THERE IS NO DAMAGE TO THE VEHICLE.INSPECTOR WAS UNABLE TO DETERMINE WHY AIRBAGS DEPLOYED.

Previous

From: customerassist@daimlerchrysler.com
To: [REDACTED]
Date: Mon Jan 26 16:31:23 EST 2004
Subject: Re: DaimlerChrysler Customer Assistance
Dear Carl:

Thank you for your email to DaimlerChrysler regarding your 2002 Jeep Liberty.

Our records show that you have contacted us by telephone and are addressing your concerns. We have updated your file to reflect the latest information you provided in the email message.

If your concerns have not been addressed, or you have other concerns, please email or contact the DaimlerChrysler Customer Assistance Center by telephone at 1-800-992-1997, 8:00 a.m. to 5:00 p.m., Monday through Friday.

Thank you again for your email.

NOTE: Please do not use the 'Reply' function of your email system. If you have a need to respond to this message, please visit us at our reply form (link provided below). Our system is NOT able to accept any emails at this address.

For any future communications related to this email, please refer to the following information:

REFERENCE NUMBER: [REDACTED]

REPLY LINK:

http://www.chrysler.com/wccsapp/wccs/brand_forms/us/reply.jsp?trk_ID=KMM717798C [REDACTED]

Sincerely,

Nicole
Senior Staff Representative
DaimlerChrysler Customer Assistance Center

Original Message Follows:

Form Selected:

Category: US Customer Service

Brief Description:

Airbag deployment in parked vehicle

Comments:

I parked the vehicle at the side of the road - got out to talk with a neighbor - we heard a bang and both airbags had deployed . Vehicle was stationary engine was idleing.

Sender Information:

Title: [REDACTED]

First Name: [REDACTED]

Middle Initial: [REDACTED]

Last Name: [REDACTED]

12137565

[REDACTED]
Gretna, Louisiana [REDACTED]
[REDACTED]

March 4, 2004

Dr. Dieter Zetsche
Premier Dodge Chrysler Jeep
1000 Chrysler Drive
Auburn Hills, Michigan 48326

Dear Dr. Zetsche,

I am writing this letter because of a 2003 Jeep Liberty/ Limited Edition I bought from Premier Dodge Chrysler Jeep dealership located at 13000 I-10 Service Road in New Orleans, La. The vehicle Vin # is 1J4GK58K63W [REDACTED]

Unfortunately, I am not pleased with the performance of the Jeep, and the service I received from the management staff of the service department. This is the second time within a two month period that my vehicle had to be brought in for the same problem. I was told by Christopher Jackson (assistant manager) that they could not fix the problem, and to bring it back if it happened again. Well, I'm back! I'm without a vehicle for the second week due to their incompetence to fix it.

Mike Comiskey, Christopher Jackson, and Richard Carbo were incompetent in identifying and correcting the problem, and displayed a lack of social and communication skills in working with the public. They were RUDE, DISRESPECTFUL and DEGRADING. Are these the kind of comments you want associated with your company?

To resolve the problem, I would like the following:

1. Fix my vehicle or give me a new one in it's place.
2. Compensate me for the time I was without a vehicle and had no means of transportation .
3. The service department heads dismissed (fired) from their jobs so they won't Treat anyone else the way they treated me. They are Mike Comiskey, Christopher Jackson, and Richard Carbo.

Your prompt and immediate attention to time matter is appreciated .

Sincerely,

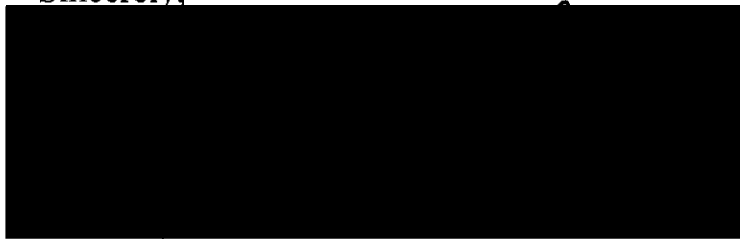

cc. Better Business Burea of New Orleans
Diamler Chrysler Motors Corp.
Automotive Consumer Action Program
BBB Auto Line
Jeep/Eagle Division of Chrysler Corp.
Center for Auto Safety

Gretna, LA

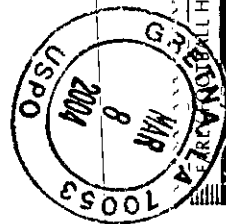

Daimler Chrysler Motors Corp.
Chrysler Customer Center
P.O. Box 21-8004
Auburn Hills, Michigan

48321+8004 98

48321-8004

[REDACTED]
Puyallup, WA [REDACTED]
March 19, 2004

DaimlerChrysler
Customer Assist Center
P. O. Box 21-8004
Auburn Hills, MI 48321-8004

RE: 2003 Jeep Liberty Renegade
1J8GL38K33W [REDACTED]

To whom it may concern,

This letter is to notify you that I am requesting a replacement for my 2003 Jeep Liberty Renegade under the Washington state Lemon Law.

Under Washington state law, a vehicle is a lemon if "diagnosis or repair of the same 'serious safety defect' has been attempted two or more times." My Jeep has been in for service **three** times because of air bag defects:

- November 24, 2003: The air bag light came on intermittently. The technician traced the problem to a faulty SRS module. The repairs took eight days.
- December 22, 2003: The air bag light came on intermittently. This time, the problem was traced to electrical shorts in the system. The repairs took nine days.
- March 15, 2003: Yet again, the air bag light came on intermittently. For the second time, the technician replaced the SRS module. The repairs took two days.

I have enclosed copies of the service paperwork. The problems clearly qualify as a "serious safety defect." The service department informed me that any time the air bag light comes on, there's a chance the air bags could deploy while driving — or not deploy in an accident.

I would like very much to be a happy Jeep owner, but the experience so far has been frustrating to say the least. I would appreciate your prompt attention to this matter.

Sincerely,
[REDACTED]

Enclosures



508 RIVER ROAD
 PUYALLUP, WA 98671
 PHONE 253-845-1766
 FAX 253-841-9249



CUSTOMER NO [REDACTED]	ADVISOR BRIAN VAN AAGTEN 658	TAG NO 648	WV. DATE 12/01/03	WV. REG. NO. [REDACTED]
[REDACTED]	LABOR RATE [REDACTED]	LICENSE NO. [REDACTED]	MSRP 5880	COLOR SILVER/
[REDACTED]	YEAR, MAKE, MODEL 03/JEEP/LIBERTY/4 DOOR UTILITY	DELIVERY DATE	DELIVERY MILES	
PUYALLUP, WA [REDACTED]	VEHICLE I.D. NO. 1J8GL38K33W [REDACTED]	RETURN TO DEALER NO.	WARRANTY START DATE	
[REDACTED]	P.T.E. NO.	P.O. NO.	DU. DATE 11/24/03	
RESIDENCE PHONE [REDACTED]	BUSINESS PHONE	COMMENTS	MO: 5880	

JOB# 1 CHARGES-----

LABOR-----
 J# 1 100LZ11 ENGINE RUNS ROUGH TECH(S):744 WARRANTY
 CUST STATES THE ENGINE WILL IDLE ROUGH INTERMITTANTLY WHEN
 COMING TO A STOP
 TECH TEST DROVE AND INSPECTED BUT WAS UNABLE TO DUPLICATE
 CONCERN. TECH CHECKED FOR CODES BUT NO CODES IN THE SYSTEM.
 TECH MONITORED ENGINE WITH DIAGNOSTIC EQUIPMENT AND FOUND
 NO PROBLEMS

JOB# 1 TOTALS-----

JOB# 1 JOURNAL PREFIX JECS JOB# 1 TOTAL 0.00

JOB# 2 CHARGES-----

LABOR-----
 J# 2 520LZ12 SUP RESTRAINT SYS TECH(S):744 WARRANTY
 CUST STATES THE AIR BAG LIGHT WILL INTERMITTANTLY COME ON
 WHILE DRIVING WITH NO PASSENGERS IN THE PASSENGER SEAT.
 TECH INSPECTED AND FOUND THE SRS MODULE NOT OPERATING
 PROPERLY
 TECH REPLACED THE SRS MODULE AND TESTED TO CONFIRM REPAIR

PARTS-----

QTY	FP NUMBER	DESCRIPTION	UNIT PRICE	WARRANTY
1	56010501-AI	MODULE OC 8035034		
TOTAL - PARTS			0.00	

JOB# 2 TOTALS-----

JOB# 2 JOURNAL PREFIX JECS JOB# 2 TOTAL 0.00

ESTIMATE-----
 CUSTOMER HEREBY ACKNOWLEDGES RECEIVING
 ORIGINAL ESTIMATE OF \$0.00 (+TAX)

YOUR SATISFACTION IS OUR GOAL

Thank you for this opportunity to serve you. It is our goal to perform all repairs requested on this repair order to your complete satisfaction. If our service was satisfactory tell your friends; if not, please tell us immediately. All claims for adjustment must be accompanied by this invoice.

AS IS - The only warranties applying to this part(s) are those which may be offered by the manufacturer. The selling dealer hereby disclaims all warranties, either express or implied, including any implied warranties of merchantability or fitness for a particular purpose, and neither assumes nor authorizes any other person to assume for it any liability in connection with the sale of this part(s) and/or service. Buyer shall not be entitled to recover from the selling dealer any consequential damages, damages to property, damages for loss of use, loss of time, loss of profits, or income or any other incidental damages.

NO PARTS OR LABOR WARRANTY WHEN USED PARTS ARE INSTALLED.

TOTAL LABOR	0.00
TOTAL PARTS	0.00
TOTAL SUBLET	0.00
TOTAL G.O.G.	0.00
TOTAL MISC CHG	0.00
TOTAL MISC DISC	0.00
TOTAL TAX	0.00
TOTAL INVOICE \$	0.00

THANK YOU.

 CUSTOMER SIGNATURE

The information contained on the estimate, worksheet and/or repair order is incorporated herein by reference.

A CHARGE HAS BEEN ADDED FOR ENVIRONMENTAL COMPLIANCE AND MISC. MATERIALS USED FOR REPAIRS.

Thank You

DEC 01 2003

WE THANK YOU FOR YOUR BUSINESS. PLEASE RETURN YOUR SURVEY, WE WANT OUR CUSTOMERS COMPLETELY SATISFIED.

NORWEST BUSINESS FORMS (206) 838-0141



608 RIVER ROAD
 PUYALLUP, WA 98371
 PHONE 253-845-1766
 FAX 253-841-9249



NO.	ADVISOR BRIAN VAN AAGTEN 658	TAG NO. 894	INVOICE DATE 12/30/03
	LABOR RATE	WARRANTY	STOCK NO.
	YEAR/MAKE/MODEL 03/JEEP/LIBERTY/4 DODR UTILITY	MILEAGE 6851	DELIVERY DATE
	VEHICLE I.D. NO. 1J8GL38K33W		DELIVERY MILES
PUYALLUP, WA	F.T.E. NO.	P.O. NO.	SELLING DEALER NO.
			PRODUCTION DATE
			INVOICE DATE 12/22/03
RESIDENCE PHONE	BUSINESS PHONE	COMMENTS	MO: 6859

JOB# 1 CHARGES

LABOR
 J# 1 520LZ12 SUP RESTRAINT SYS TECH(S): 494 WARRANTY
 CUST STATES THE SRS LIGHT COMES ON INTERMITTANTLY WHILE DRIVING.
 TECH INSPECTED AND FOUND ELECTRICAL SHORTS IN THE SYSTEM.
 TECH TRACED IT DOWN TO PINCHED WIRES UNDER THE R/F SEAT AND A BROKEN GROUND CONNECTOR.
 TECH REPAIRED THE WIRES AND TESTED TO CONFIRM REPAIR.

PARTS	QTY	FP NUMBER	DESCRIPTION	UNIT PRICE	WARRANTY
	1	56009898-AD	MODULE, AT 8035034		
				TOTAL PARTS	0.00

JOB# 1 TOTALS

JOB# 1 JOURNAL PREFIX JECS JOB# 1 TOTAL 0.00

JOB# 2 CHARGES

LABOR
 J# 2 600LZ05 INT SQUEAK/RATTLES TECH(S): 494 WARRANTY
 CUST STATES THE SUNROOF RATTLES, ESPECIALLY WHEN THE SUNSHADE IT PULLED BACK.
 TECH COULDN'T DUPLICATE NOISES AT THIS TIME.

JOB# 2 TOTALS

JOB# 2 JOURNAL PREFIX JECS JOB# 2 TOTAL 0.00

JOB# 3 CHARGES

LABOR
 J# 3 600LZ06 INT SQUEAK/RATTLES TECH(S): 494 WARRANTY
 CUST STATES THERE IS A SQUEEING NOISE FROM THE DRIVERS DOOR WHEN DRIVING.
 TECH WAS UNABLE TO DUPLICATE NOISES AT THIS TIME.

JOB# 3 TOTALS

JOB# 3 JOURNAL PREFIX JECS JOB# 3 TOTAL 0.00

JOB# 4 CHARGES

LABOR
 J# 4 450LZ13 STEER/SUSP RECALL TECH(S): 494 WARRANTY
 BALL JOINT RECALL #C36
 TECH REPLACED BOTH LOWER BALL JOINTS PER RECALL.

PARTS	QTY	FP NUMBER	DESCRIPTION	UNIT PRICE	WARRANTY
	1	CBTFC361	BALLJOINT		
				TOTAL PARTS	0.00

JOB# 4 TOTALS

JOB# 4 JOURNAL PREFIX JECS JOB# 4 TOTAL 0.00

YOUR SATISFACTION IS OUR GOAL

Thank you for this opportunity to serve you. It is our goal to perform all repairs requested on this repair order to your complete satisfaction. If our service was satisfactory tell your friends; if not, please tell us immediately. All claims for adjustment must be accompanied by this invoice.

AS IS - The only warranties applying to this part(s) are those which may be offered by the manufacturer. The selling dealer hereby disclaims all warranties, either express or implied, including any implied warranties of merchantability or fitness for a particular purpose, and neither assumes nor authorizes any other person to assume for it any liability in connection with the sale of this part(s) and/or service. Buyer shall not be entitled to recover from the selling dealer any consequential damages, damages to property, damages for loss of use, loss of time, loss of profits, or income or any other incidental damages.

NO PARTS OR LABOR WARRANTY WHEN USED PARTS ARE INSTALLED.

The information contained on the estimate, worksheet and/or repair order is incorporated herein by reference.

A CHARGE HAS BEEN ADDED FOR ENVIRONMENTAL COMPLIANCE AND MISC. MATERIALS USED FOR REPAIRS.

Thank You

WE THANK YOU FOR YOUR BUSINESS. PLEASE RETURN YOUR SURVEY. WE WANT OUR CUSTOMERS COMPLETELY SATISFIED.



608 RIVER ROAD
 PUYALLUP, WA 98071
 PHONE 253-845-1798
 FAX 253-841-9940

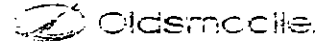

CUSTOMER NO. 18840	NAME BRIAN VAN AAGTEN 658	FA# 653	DATE 03/16/04
LABOR RATE	VEHICLE NO. 865RHW	MO. # 9254	COLOR SILVER/
YEAR MAKE MODEL 03/JEEP/LIBERTY/4 DOOR UTILITY	DELIVERY DATE	DELIVERY MILES	
VEHICLE IC NO. TJ86L38K33W	SELLING DEALER AC	ACCOLUTION DATE	
F.T.E. NO.	P.O. NO.	DATE 03/15/04	
BUSINESS PHONE	COMMENTS	MO: 9254	

JOB# 1 CHARGES-----

LABOR-----
 J# 1 520LZ12 SUP RESTRAINT SYS TECH(S): 494 WARRANTY
 CUST STATES THE SRS LIGHT WILL COME ON INTERMITTANTLY.
 WITH NO PASSENGERS IN THE R/F SEAT.
 TECH INSPECTED AND FOUND CODES IN THE SYSTEM FOR SIDE IMPACT
 AIR BAG FAULT. TECH TRACED IT DOWN TO THE SRS MODULE
 TECH REPLACED THE MODULE AND TESTED TO CONFIRM REPAIR

PARTS-----	QTY-----	FP-NUMBER-----	DESCRIPTION-----	UNIT PRICE-----	WARRANTY
	1	56010501-AI	MODULE OC 8035034		0.00
TOTAL - PARTS					0.00

JOB# 1 TOTALS-----
 JOB# 1 JOURNAL PREFIX JECS JOB# 1 TOTAL 0.00

ESTIMATE-----
 CUSTOMER HEREBY ACKNOWLEDGES RECEIVING
 ORIGINAL ESTIMATE OF \$0.00 (+TAX)

TOTALS-----

*****	TOTAL LABOR....	0.00
*	TOTAL PARTS....	0.00
*	TOTAL SUBLET....	0.00
*	TOTAL G.O.G....	0.00
*	TOTAL MISC CHG....	0.00
*	TOTAL MISC DISC....	0.00
*	TOTAL TAX.....	0.00
*****	TOTAL INVOICE \$	0.00

THANK YOU.

CUSTOMER SIGNATURE

MAR 16 2004

YOUR SATISFACTION IS OUR GOAL

Thank you for this opportunity to serve you. It is our goal to perform all repairs requested on this repair order to your complete satisfaction. If our service was satisfactory tell your friends; if not, please tell us immediately. All claims for adjustment must be accompanied by this invoice.

AS IS - The only warranties applying to this part(s) are those which may be offered by the manufacturer. The selling dealer hereby disclaims all warranties, either express or implied, including any implied warranties of merchantability or fitness for a particular purpose, and neither assumes nor authorizes any other person to assume for it any liability in connection with the sale of this part(s) and/or service. Buyer shall not be entitled to recover from the selling dealer any consequential damages, damages to property, damages for loss of use, loss of time, loss of profits, or income or any other incidental damages.

NO PARTS OR LABOR WARRANTY WHEN USED PARTS ARE INSTALLED.

The information contained on the estimate, worksheet and/or repair order is incorporated herein by reference.

A CHARGE HAS BEEN ADDED FOR ENVIRONMENTAL COMPLIANCE AND MISC. MATERIALS USED FOR REPAIRS.

Thank You

WE THANK YOU FOR YOUR BUSINESS. PLEASE RETURN YOUR SURVEY, WE WANT OUR CUSTOMERS COMPLETELY SATISFIED.

CERTIFIED MAIL™



7003 3110 0005 7054 3856

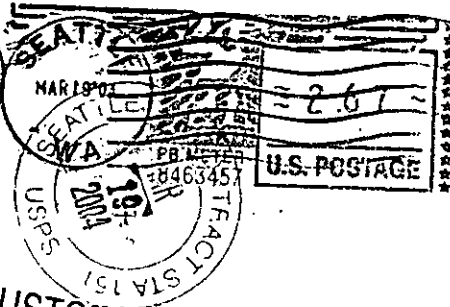

CUSTOMER RELATIONS

MAR 23 2004

RECEIVED

Daimler Chrysler
Customer Assist Center
P.O. BOX 21-8004
Auburn Hills, MI 48321-8004

48321+8004

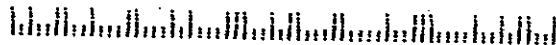

Puyallup, WA

MFD BY DAIMLERCHRYSLER CORPORATION DATE OF MFR 3-03 GVWR 2427 KG(05350 LB)

GVWR FRONT	WITH TIRES	RIMS AT	COLD
1248 KG(2750 LB)	P215/75R16	16X7	227 KPA(33 PSI)
GVWR REAR	WITH TIRES	RIMS AT	COLD
1429 KG(3150 LB)	R215/75R16	16X7	227 KPA(33 PSI)

THIS VEHICLE CONFORMS TO ALL APPLICABLE FEDERAL MOTOR VEHICLE SAFETY AND THEFT PREVENTION STANDARDS IN EFFECT ON THE DATE OF MANUFACTURE SHOWN ABOVE.

VIN: 1J4GK48K63W [REDACTED] TYPE: MPV SINGLE X DUAL



KDH: 030413 978AA PNT:PRV VEHICLE MADE IN U.S.A. TRM:KSL5 4648503



Before operating, carefully read the
DRIII Software License Agreement
provided with the original software and
DRIII or with any other updates
provided updates to the software.
The DRIII Software License Agreement
can also be viewed at the following
<http://www.miller.com>
or contact Miller Electric Mfg.
in the US - 1-800-854-5429

Press YES
If you agree to be bound by the terms
of that license agreement.

F1 F2 F3 F4

ENTER

8091
1608
W125

63w644118
wae 6020

Main Menu
1. Connect to TechCONNECT
2. Connect to TechCONNECT
3. Generic Scan Tool
4. PIP Module Tools
5. Run Memory Card Programs
6. DRB Utilities
7. Vehicle Flash
8. Legacy KMS Support
Page 1 of 1
HELP

F1 F2 F3 F4

8091
111505

3w6 44118

are 60.0

DRE-III CORB Application
DaimlerChrysler
Copyright © 1993-2004
All Rights Reserved
RELEASE: 68.0.01
Released: 11:22:27 5/21/2004
Bios Version: 4.07
Database: 15:23:16 5/20/2004
Cable in use: J1962 (CI70000)

HELP

0.0

F1 F2 F3 F4

↑ ↓

8091
M106

163w644118

WAVE 607

1998 - 2005 DIAGNOSTICS
1. 01 - 05 Stratus/Sebring Coupe
2. 96 - 00 Buenger/Sebring Coupe
3. 1998 Talon
4. 2000 - 2005 Crossfire
5. 2003 - 2004 Sprinter

Page 1 of 1
HELP B78 H00

8091
MI 465

163w64418

w npe 60.0

F1 F2 F3 F4

ENTER

SELECT RESTRAINT SYSTEM

- 1. Airbag
- 2. Side Airbags
- 3. Airbag On/Off Switch System
- 4. Occupant Classification S

Page 1 of 1

882 878 100

F1 F2 F3 F4



8891
11500
M1466

8846 3106 4418

7 0000 0000

1113

Interlocking Controller
Type
Please call

F1 F2 F3 F4

ENTER

501W
1500

8463W644118

6000

This Diagnostic Control
Module is not supported by
this software. Please use a
DBB III with the Superior
software to diagnose this
module.

HELP STOP FWD

8091
Miles

8K63W644118

ware 60-2

F1 F2 F3 F4

ENTER

↑

ENTER



Jeep

ABS
AIRBAG

4
5
6
RPM x1000

20
30
40
50
60
70

P
R
N
D
2
1

WARNING
DEATH OR SERIOUS
INJURY CAN OCCUR
IF AIR BAGS ARE NOT PROPERLY
INSTALLED OR MAINTAINED.
SEE OWNER'S MANUAL FOR
INSTALLATION AND MAINTENANCE
INSTRUCTIONS.

WARNING
DEATH OR SERIOUS
INJURY CAN OCCUR
IF AIR BAGS ARE NOT PROPERLY
INSTALLED OR MAINTAINED.
SEE OWNER'S MANUAL FOR
INSTALLATION AND MAINTENANCE
INSTRUCTIONS.

































Jeep
LIBERTY

Jeep
LIBERTY











Riv
H01-06
084031R
MEETS FMVSS 209
ASSEMBLED IN MEXICO









3.7L



LIBERTY sport

Jeep

PUERTO RICO



Jeep

05

Jeep





LAW OFFICES OF

[REDACTED]
DETROIT, MI 4 [REDACTED]

OF COUNSEL
Mikael G. Hahner

[REDACTED]
FAX (313) [REDACTED] [REDACTED]

July 19, 2004

DaimlerChrysler Motor Corporation
Customer Service
P.O. Box 21-8004
Auburn Hills, MI 48321-8004

RE: Vehicle: 2002 Jeep Liberty
Dealer: Southfield Chrysler Jeep
VIN: 1J4GL58KX2W [REDACTED]
Vehicle Delivery Date: 12/7/01

Dear Customer Service:

Previously, I wrote a "last chance" letter to you concerning my leased vehicle as referenced above because of problem with the dash lights not illuminating. The dealership attempted to fix this problem for the fourth time, however now the dash "airbag" light stays on constantly, thus the problem with dashboard lights has never been fixed satisfactorily after the requisite number of attempts.

Additionally, the repair records will also show that this vehicle has always "pulled to the right", even though there have been numerous (3 or 4) attempts to fix it. Further, although there have been numerous attempts to fix the warning chime that reminds one to turn their headlights off if they have been left on, once again, does not work. Lastly, ever since the last repair attempt, was made for the dash board light problem, the shifter handle will come loose if you apply upward pressure on it.

In sum, this car is and was a lemon. Although I do not practice Lemon Law personally, I know a number of attorneys who do and they have all concluded that I would prevail in the event a suit is filed. At this time, I do not wish to file suit as long as we can come to an amicable resolution.

I would propose the following:

- 1) early termination of the lease
- 2) waiver of all damage claims (there is damage to the windshield and several bumps on the body); and
- 3) \$6,000.00 damages.

July 19, 2004

Page 2

DaimlerChrysler Motor Corporation
Customer Service
Vehicle: 2002 Jeep Liberty
Dealer: Southfield Chrysler Jeep
VIN: 1J4GL58KX2W [REDACTED]

Please contact me on my cell number (313) 400-1195 to discuss in further detail and/or arrange an inspection of this vehicle. By writing this letter as required by Michigans "lemon law", please note that I am not waiving my rights to any other remedies that may be available to me under the common law or through federal and state statutes.

Sincerely, /
[REDACTED]

Certified Mail Return Receipt
[REDACTED]



DETROIT, MI



CERTIFIED MAIL

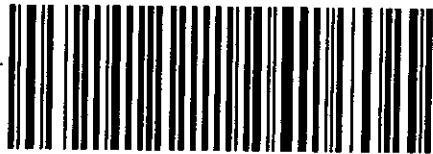

7000 1530 0002 1380 2936

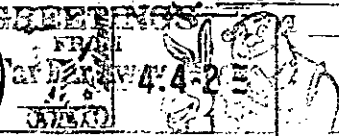
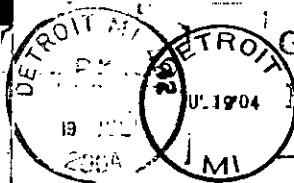

POST METER
5069978

U.S. POSTAGE

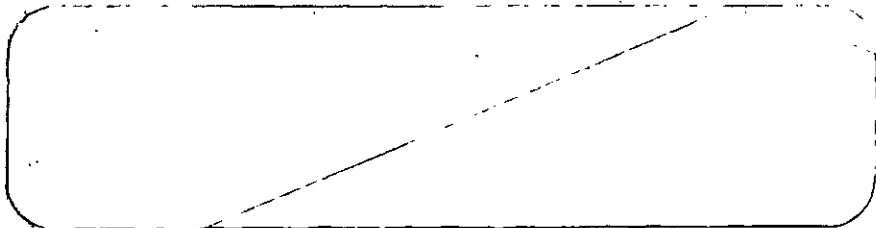

CUSTOMER RELATIONS

JUL 21 2004

RECEIVED

48321+8004 98



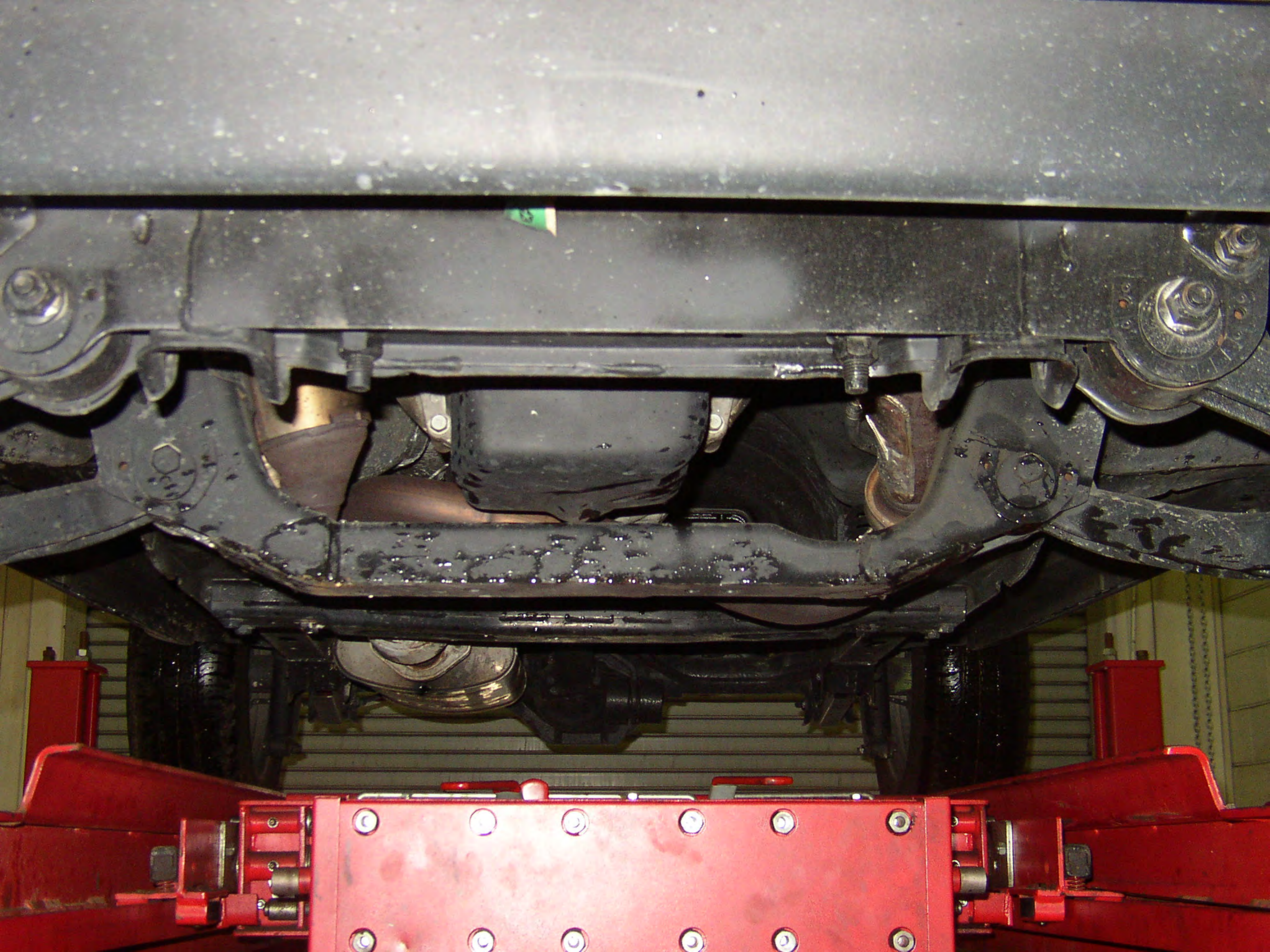





Small white tag with illegible text, possibly a receipt or label, located in the upper left corner of the image.



MFD BY DAIMLERCHRYSLER CORPORATION

DATE OF MFR
5-02

GVWR
2427 KG(05350 LB)

GAWR FRONT

1248 KG(2750 LB)

WITH TIRES

P215/75SR16

RIMS AT

16X7

COLD

227 KPA(33 PSI)

GAWR REAR

1339 KG(2950 LB)

WITH TIRES

P215/75SR16

RIMS AT

16X7

COLD

227 KPA(33 PSI)

THIS VEHICLE CONFORMS TO ALL APPLICABLE FEDERAL MOTOR VEHICLE SAFETY AND THEFT PREVENTION STANDARDS IN EFFECT ON THE DATE OF MANUFACTURE SHOWN ABOVE.

VIN: 1J4GK48K82W

TYPE:

MPV

SINGLE X DUAL



MDH: 051607 387AA PNT:PS2

VEHICLE MADE IN U.S.A. TRM:M5DV 4648503





Unable to ID Module for
CRC

Press any key to continue

Modules Present on the BUS

CM

Page 1 of 1

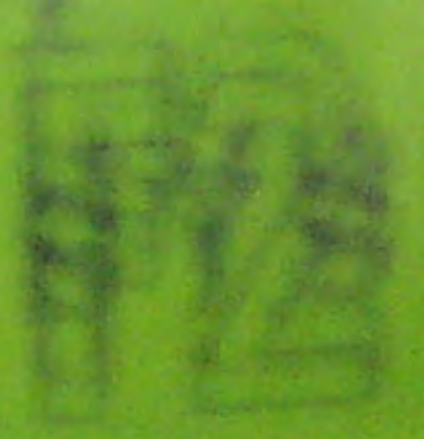
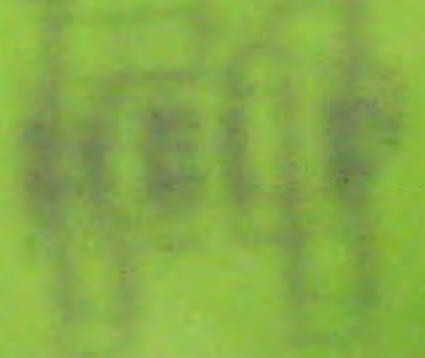

ca. 8





669

Jeep

[REDACTED]











LIBERTY

MFD BY DAIMLERCHRYSLER
CORPORATION

DATE OF MFR
5-02

GVWR
2541 KG(05600 LB)

GVWR FRONT WITH TIRES
1248 KG(2750 LB) 235/70R16

RIMS AT COLD
16X7 227 KPA(33

GVWR REAR WITH TIRES
1429 KG(3150 LB) 235/70R16

RIMS AT COLD
16X7 227 KPA(33

THIS VEHICLE CONFORMS TO ALL APPLICABLE FEDERAL MOTOR VEHICLE SAFETY AND THE
PREVENTION STANDARDS IN EFFECT ON THE DATE OF MANUFACTURE SHOWN ABOVE.

VIN: 1J4GL58KX2W [REDACTED] TYPE: MPV SINGLE X DUAL



MDI:

051412 779AA PNT:PX8

VEHICLE MADE IN U.S.A. TRM:DLD2 4648503





Jeep
LIBERTY

3.7L

A close-up photograph of a grey metal D-ring attached to a dark brown leather surface. The ring is positioned horizontally and features a series of small, raised rectangular protrusions along its length. The leather is textured and shows some wear. A green cord is visible on the left side, and a white fabric is at the bottom. The text "left 'D' ring" is overlaid in yellow in the center of the image.

left "D" ring

left belt latch

10089



left belt latch

TRW

H01-07

left frt belt label

174023R

MEETS FMVSS 209
ASSEMBLED IN MEXICO

! WARNING



DEATH OR SERIOUS INJURY CAN OCCUR

- CHILDREN 12 AND UNDER CAN BE KILLED BY THE AIR BAG.
- THE **BACK SEAT** IS THE **SAFEST PLACE** FOR CHILDREN.
- **NEVER** PUT A REAR-FACING CHILD SEAT IN THE FRONT.
- SIT AS FAR BACK AS POSSIBLE FROM THE AIR BAG.
- **ALWAYS USE SEAT BELTS AND CHILD RESTRAINTS.**



E
GE
FULLY!



right belt latch

A close-up photograph of a grey plastic seatbelt buckle. A dark-colored fabric strap is inserted into the buckle. The buckle has a D-shaped opening. A person's finger is visible at the bottom left, holding the buckle. The text "right belt 'D' ring" is overlaid in yellow on the image.

right belt "D" ring

TRW

H01-06

176029R

MEETS FMVSS 209
ASSEMBLED IN MEXICO

right belt label



right frt belt latch

10085

ORC DTCs 1 of 5

INTERNAL 1

MINUTES: 339 IGN CNTS: 0

--- DTC 2 of 5 ---

PASSENGER SOUTB 1

SHORT TO GROUND

MINUTES: 1 IGN CNTS: 35

DTC TYPE

1. Active
2. Stored

— ORC DTCs 1 of 1

INTERNAL 1

Reading Stored DICs

AIRBAG Module Information

2002 Body Style: KJ

Part#: 56010501AG

S/W Version: 05.05

TRW Gen V

Front Dr and Pass/PCI Bus SAB
and Lamp Dr w/On/Off Sw or AOSIM



DRIVEN

-- ORC DTCs 3 of 5 --

STORED ENERGY
FIRING 1

MINUTES: 39 IGN CNTS: 29

--- DTC 4 of 5 ---

DRIVER SQUIB 2
SHORT TO GROUND

MINUTES: 1 IGN CNTS: 35

-- ORC DTCs 5 of 5 --

PASSENGER SQUIB 2
SHORT TO GROUND

MINUTES: 1 IGN CNTS: 35

-- DTC 1 of 5 --

INTERNAL 1

MINUTES: 342 IGN CNTS: 0

-- ORC DTCs 5 of 5 --

PASSENGER SQUIB 2
SHORT TO GROUND

MINUTES: 1 IGN CNTS: 35

--- DTC 1 of 5 ---

1

MINUTES: 342 IGN CNTS: 0







Date:9/4, 2004

FAX TO: Mr. Porterfield

Fax # 248-512-8748

Subject: Cair # [REDACTED] - [REDACTED], copy of damage report 10/23/2003

From: [REDACTED], EAA - [REDACTED]

of pages with cover: 5

CAIR #

SCHULER / COLLISION DAMAGE APPRAISAL SERVICE
P.O. BOX 85
GRANDVIEW, MO 64030
PHONE: (816) 331-3785 FAX: (816) 331-3785

CD LOG NO 398

-1

DATE 10-23-03

SUPPLEMENT

CLAIM INFORMATION

CLAIM # [REDACTED]
COMPANY [REDACTED]
INSURED [REDACTED]
CLAIMANT [REDACTED]

POLICY # [REDACTED]
CLAIM REP 1103-081862
LOSS DATE 08-14-03
LOSS TYPE COLLISION

INSPECTION

TYPE INDEPENDENT FIELD
PRIMARY POI FRONT END RIGHT
APPRAISER NAME TERRY SCHULER
WORK PHONE (816) 331-3785
ADDRESS P O BOX 85
CITY STATE GRANDVIEW MO
ZIP 64030-

SECOND POI [REDACTED]
FAX (816) 331-3785
INSP DATE 08-18-03
LOCATION OP JEEP
CITY STATE OP

KS

OWNER

[REDACTED]

WORK# [REDACTED]
HOME# [REDACTED]

REPAIR

ATTN TERRY
OVERLAND PARK JEEP
8775 METCALF
OVERLAND PARK KS 66212-
SHOP PHONE (913) 381-8100

SHOP LIC# [REDACTED]
CAR IN [REDACTED]
CAR OUT [REDACTED]
REPAIR DAYS [REDACTED]
REG. ID 48-0794879
FAX (913) 381-7523

VEHICLE

2002 JEEP LIBERTY LIMITED 4 DR WAGON
6CYL GASOLINE 3.7

OPTIONS

TWO-STAGE - EXTERIOR SURFACES
POWER DOOR LOCKS
LUGGAGE RACK
AIR CONDITIONING
CRUISE CONTROL

4-WHEEL DRIVE
POWER WINDOWS
TILT STEERING WHEEL
AUTOMATIC TRANS

BODY COLOR BLK
CONDITION GOOD
LICENSE # 547CPB
LICENSE STATE MO

MILEAGE [REDACTED]
VIN 1J4GL58KX2W [REDACTED]
CODE J725
VEH INSP # [REDACTED]

2002 JEEP LIBERTY LIMITED 4 DR WAGON
 CLAIM # [REDACTED]

DATE 10-23-03
 LOG 398 -1

L	0073	PANEL ASSEMBLY, RAD SU	REFINISH			1.3 4
			1.3 Surface			
E	0072	CRSMBR, RAD PANEL UPR	55176763AC	32.00		INC 1
L	0072	CRSMBR, RAD PANEL UPR	REFINISH			0.5 4
			0.5 Surface			
E	0024 07	CRSMBR, RAD PNL LOWER	55360190AD	71.00		1.9 1
E	0755	RADIATOR	52080118AB	212.00		0.2 1
E	0102 01	TRAY, BATTERY	LT 55360084AD	25.85	S1	0.3 1
N	0987	A/C EVAC RECHRG & RCV	ADDITIONAL LABOR			1.9 2
E	0731	CONDENSER, A/C	55037465AB	380.00		0.2 2
I	0106 07	PANEL, INNER FENDER	RT REPAIR		S1	4.0*1
I	0142 07	WHLHS, FRT FENDER IN	RT REPAIR			6.0*1
L	0142	WHLHS, FRT FENDER IN	RT REFINISH			0.3 4
			0.3 Surface			
I	0572	CRADLE, ENGINE	REPAIR		S1	4.0*1*
E	0104	FENDER, FRONT	RT 55177100AC	132.00		0.3 1
L	0104	FENDER, FRONT	RT REFINISH			2.1 4
			1.3 Surface			
			0.5 Edge			
			0.3 Two-stage			
RI	0132	MAST, ANTENNA	RT R&I ASSEMBLY			0.1 1
RI	0382	GUARD, FENDER MUD	RT R&I ASSEMBLY			INC 1
E	0124	BRKT, FLARE MOUNTING	RT 55155988AB	8.60	S1	INC 1
I	0265	FLARE, WHEEL OPENING	LT REPAIR		S1	1.0*1
L	0265	FLARE, WHEEL OPENING	LT REFINISH		S1	1.4 4
			1.2 Surface			
			0.2 Two-stage			
E	0266 01	FLARE, WHEEL OPENING	RT 5GH00TZZAE	220.00		INC 1
L	0266	FLARE, WHEEL OPENING	RT REFINISH		S1	1.4 4
			1.2 Surface			
			0.2 Two-stage			
E	0112	SHIELD, FRONT SPLASH	RT 55360144AG	26.35		INC 1
E	0822	AIR CLEANER ASSEMBLY	53013108AA	122.00		INC 2
E	1060	PUMP, WASHER	5066880AA	93.85	S1	INC 1
E	0149	RESERVOIR, W/S WASHER	5066867AA	84.25		0.7 1
RI	0577	PAD, SIDE STEP PANEL	RT R&I ASSEMBLY			0.6 1
I	M18	SET-UP AND MEASURE	REPAIR			1.5*1*
EC	M20	ANTI-FREEZE-COOLANT	REPLACE ECONOMY	24.50*	S1	1
I		ALIGNMENT	SUBLET	59.95*	S1	1
E		LUBRICANT	REPLACE OEM	28.50*	S1	1
E		HEATER HOSE	REPLACE OEM	94.86*	S1	1.0*2*
I		WIRING	REPAIR		S1	2.0*1*

55 ITEMS

MC MESSAGE

01 CALL DEALER FOR EXACT PART # / PRICE
 07 STRUCTURAL PART AS IDENTIFIED BY I-CAR

2002 JEEP LIBERTY LIMITED 4 DR WAGON
CLAIM # [REDACTED]

DATE 10-23-03
LOG 398 -1

REMARKS:

PLEASE MAIL SUPPLEMENT PAYMENT DIRECTLY TO SHOP
DRV-NO
PHOTOS ON SCENE GENESIS
PROD DATE 5/02
LICENSE EXPIRATION DATE MAY04

OP CODES:

* = USER-ENTERED VALUE	E = REPLACE OEM	NG = REPLACE NAGS
EC = REPLACE ECONOMY	UC = RECONDITIONED PRT	UM = REMAN/REBUILT PRT
EU = LIKE KIND & QUAL. PRT	EP = REPLACE PXN	PC = PXN RECONDITIONED
PM = PXN REMAN/REBUILT	TE = PARTL REPL PRICE	ET = PARTL REPL LABOR
IT = PARTIAL REPAIR	I = REPAIR	L = REFINISH
BR = BLEND REFINISH	TT = TWO-TONE	CG = CHIPGUARD
SB = SUBLET	N = ADDITIONAL LABOR	RI = R&I ASSEMBLY
P = CHECK	AA = APPEAR ALLOWANCE	RP = RELATED PRIOR
UP = UNRELATED PRIOR		

OP	GDE	MC	DESCRIPTION	MFR. PART NO.	PRICE	AJ%	B%	HOURS	R
J			UNIBODY-FRAME INCL SET REPAIR					5.0*3*	
E	0025	01	COVER, FRONT BUMPER	5066606AB	400.00			0.7	1
L	0025		COVER, FRONT BUMPER	REFINISH				3.5	4
			2.4 Surface						
			0.6 Two-stage setup						
			0.5 Two-stage						
E	0048		BRACKET, LICENSE MTG	5288487	39.20		S1	0.2	1
E	0069		ABSORBER, FRONT BUMPER	55156042AD	65.10			INC	1
E	0028		GRILLE ASSEMBLY	55156608AA	180.00			0.2	1
L	0028		GRILLE ASSEMBLY	REFINISH				2.5	4
			2.1 Surface						
			0.4 Two-stage						
E	0047		SENSOR, TEMPERATURE	56042395	33.75		S1	INC	1
E	0041		HEADLAMP ASSEMBLY	LT 5101821AA	234.00		S1	INC	1
E	0042		HEADLAMP ASSEMBLY	RT 55155808AA	234.00		S1	INC	1
N	0973		HEADLAMPS AIM	ADDITIONAL LABOR				0.5	1
E	0033		PANEL, HEADLAMP MTG	55155800AC	179.00			0.4	1
E	0014		PARKLAMP ASSEMBLY	RT 55155910AB	32.00			INC	1
E	0056		LAMP ASSEMBLY, FOG	RT 5083896AA	115.00			INC	1
I	0083		PANEL, HOOD	REPAIR				4.0*1	
L	0083		PANEL, HOOD	REFINISH				3.1	4
			2.6 Surface						
			0.5 Two-stage						
E	0062		N/PLATE, HOOD PANEL	55156554AB	20.75				
E	0088		LATCH, HOOD PANEL	55156554AB					

2002 JEEP LIBERTY LIMITED 4 DR WAGON

DATE 10 23 03



DATE 10-23-03
LOG 398 -1

FINAL CALCULATIONS & ENTRIES
PARTS

GROSS PARTS \$ 3,183.41
OTHER PARTS \$ 24.50
PAINT MATERIAL \$ 402.50

ADJUSTMENTS DISCOUNT MARKUP
PARTS TOTAL \$ 3,610.41
TAX ON PARTS & MATERIAL @ 7.525% \$ 271.68

LABOR	RATE	REPLACE HRS	REPAIR HRS	
1-SHEET METAL	\$ 42.00	17.0	25.0	\$ 1,764.00
2-MECH/ELEC	\$ 86.00	1.2	1.9	\$ 266.60
3-FRAME	\$ 55.00		5.0	\$ 275.00
4-REFINISH	\$ 42.00	16.1		\$ 676.20
5-PAINT	\$ 25.00			

LABOR TOTAL \$ 2,981.80
TAX ON LABOR @ 7.525% \$ 224.38
TAX ON SUBLET @ 7.525% \$ 4.51
SUBLET REPAIRS \$ 59.95
TOWING \$ 375.00
STORAGE

GROSS TOTAL \$ 7,527.73
LESS: DEDUCTIBLE \$ 250.00-

NET TOTAL \$ 7,277.73

LESS: PREVIOUS NET TOTAL \$ 5,441.47-

NET SUPPLEMENT TOTAL \$ 1,836.26

PXN Y/00/00/00/00/00 CUM 00/00/00/00/00 Geocode: 66204 OVERLAND PARK KANSAS
ADP PENPRO W0405 S1 LOG398 -1 10-23-03 10:30:54 REL 4.05 SW09/03 DT10/03
(C) 1993 - 2003 ADP CLAIMS SOLUTIONS GROUP, INC.

2.7 HRS WERE ADDED TO THIS EST. BASED ON ADP'S TWO-STAGE REFINISH FORMULA.
"THIS IS NOT AN AUTHORIZATION TO REPAIR."

"REPAIRS MUST BE AUTHORIZED BY VEHICLE OWNER. REPAIRER AGREES TO COMPLETE LISTED REPAIRS IN ACCORDANCE WITH MANUFACTURER'S SPECIFICATIONS FOR TOTAL COST OF REPAIRS AND TO CONTACT APPRAISER FOR VERIFICATION OF ANY LOSS RELATED DAMAGE THAT MAY BE DISCOVERED BEFORE OR DURING REPAIRS."

"THIS ESTIMATE HAS BEEN PREPARED BASED ON THE USE OF ONE OR MORE CRASH PARTS SUPPLIED BY A SOURCE OTHER THAN THE MANUFACTURER OF YOUR MOTOR VEHICLE. WARRANTIES APPLICABLE TO THESE REPLACEMENT PARTS ARE PROVIDED BY THE PARTS

WARRANTIES APPLICABLE TO THESE REPLACEMENT PARTS ARE PROVIDED BY THE PARTS

SEP 04 2004 15:04



CONFIDENTIAL - Prior Approval Required Before Duplicating**Preliminary Vehicle Investigation Report(PVIR)**

CAIR# 12601751

YEAR	BRAND	VEHICLE IDENTIFICATION NUMBER		MO/DY-HR	ODOMETER	IN-SERVICE
2002	JEEP LIBERTY LTD EDITION 4X4 SPORT UTILITY 4-DR	1J4GL58KX2W [REDACTED]		05-14 12	28664	06/13/2002
NAME OF OWNER		ADDRESS/LOCATION		CITY	STATE	COUNTRY
[REDACTED]		[REDACTED]		KANSAS CITY	MO	USA
ZIP	COLOR	MODEL	HOME PHONE		BUSINESS PHONE	
[REDACTED]	Black Clear Coat	KJJ	[REDACTED]			
SELLING DEALER NAME		BUSINESS CENTER	DLR. CODE	CITY	STATE	COUNTRY
OVERLAND PARK JEEP INC		74	23633	OVERLAND PARK	KS	USA
INSPECTOR - NAME FIRST, LAST, MIDDLE			INSPECTOR'S COMPANY		INSPECTOR'S PHONE NO.	
Lyle Beckman J			EAA`		913-825-3670	
DAMAGE ESTIMATE				REPAIR ESTIMATE		
<input type="radio"/> MINOR <input checked="" type="radio"/> MODERATE <input type="radio"/> TOTAL LOSS				\$.00		

INTERVIEW

INTERVIEW WITH:

 DRIVER OWNER OTHER DRIVER/OWNER

NAME: LAST, FIRST, MIDDLE

[REDACTED]

INTERVIEW DATE:

DATE OF INCIDENT:

TIME OF INCIDENT

INSPECTION DATE:

09/04/2004**08/30/2004****03:30** AM PM**09/03/2004**

1. DRIVER'S

DESCRIPTION OF EVENT:

Owner stated that she was just leaving work and noticed her air bag light was on, when she stopped at a stop light the air bags deployed. Owner stated that she had an accident about 1 year ago and had frontal damage but the bags did not deploy at that time. Owner states that the air bag light did not come on at any other time except when she turned the ignition switch on and then it always went off after a few seconds.

Insurance

Company

Name:

Personal Injury:

Were there

 Yes No

If Yes, complete section "B"

Personal Injuries?

Any Indicator/

Warning Lights

 Yes NoIf Yes, What light: **air bag light**

on Prior?

IMPORTANT: SHOW THIS REPORT TO NO ONE & ONLY STATE FACTS (DRAW NO CONCLUSIONS)

Help Key

PART A- GENERAL

REQUIRED PHOTOGRAPHS: ALL FOUR SIDE VIEWS**IF CRASH DAMAGED:**

PERSPECTIVE FROM EVERY
CORNER OF VEHICLE DOWN
BOTH ORIGINAL LATERAL
SIGHT LINES(8 TOTAL)

- ANY RECENT VEHICLE
SERVICE

YES NO

UNKNOWN

IF YES, ENCLOSE COPIES OF
REPAIR ORDERS

INFORMATION: POLICE/AGENCY REPORT #:

ALL REPORTS/PHOTOS BY
OTHERS

- ADDRESS OF INSPECTION

Address **Overland Park Jeep**

1

Address **8775 Metcalf**

2

City **Overland Park**

State **KS**

Zip **66210**

Phone **913-381-8100**

- EVIDENCE OF TAMPERING OR PRIOR
DISASSEMBLY

YES NO

- IF YES, DESCRIBE AND PHOTOGRAPH

PART B - EXTERIOR/INTERIOR VEHICLE DAMAGE

REQUIRED PHOTOGRAPHS: The vehicle exhibits no damage except the drivers side and passenger side air bag deployment. no injuries reported

 WINDSHIELD

ALL AREAS OF DAMAGE
MARKINGS ON INTERIOR
AND EXTERIOR

CLOSE UPS OF STAINS,
SKIN, HAIR, CLOTH

EXTERIOR AND INTERIOR
DAMAGE INCLUDING
UNDERCARRIAGE

INFORMATION:

DESCRIBE ANY INJURIES
TO DRIVER AND/OR OTHER
OCCUPANTS

SEE SEAT BELT/SEATS
SECTION IF APPLICABLE

Next

PART C - AIRBAG(S)

REQUIRED PHOTOGRAPHS

- STEERING WHEEL
- AIRBAG(S)
- KNEE BLOCKERS
- ALL POSSIBLE LOCATIONS OF CONTACT

AECM INFORMATION

- SOFTWARE VERSION:
05.05
- SERIAL NUMBER :
- PART NUMBER :
5601050
- DOES AIRBAG WARNING LIGHT CYCLE ON?
 YES NO N/A
- ARE WARNING LABELS PRESENT (PHOTO)
 YES NO N/A
- RECORD LABEL PART NUMBER
na
- COMPLETE PART D**

- PHOTOGRAPH REQUIRED FOR DRB SCREENS & RECORD FAULTS
- WERE THERE DRB READINGS TAKEN?
 YES NO IF NO, EXPLAIN

- RECORD ACTIVE DTC'S EXACTLY AS APPEAR :	MIN	COUNT
internal 1		
- RECORD STORED DTC'S (MINUTES/COUNTS) :	MIN	COUNT
internal 1	340	1
Passenger squib 1 short to grd	1	35
stored energy firing 1	39	29
Driver Squib 2 short to grd	1	35
Passenger Squib 2 short to grd	1	35

- WAS AIRBAG DEPLOYED?

- DRIVER YES NO
- IF NO, EXPLAIN
- PASSENGER YES NO
- IF NO, EXPLAIN
- SIDE AIRBAG YES NO N/A
- IF NO, EXPLAIN
- WHICH SIDE DEPLOYED?
 LEFT RIGHT N/A
- BOTH
- TYPE OF SIDE AIRBAG
 SEAT CURTAIN N/A
- TYPE OF STEERING WHEEL
 TILT STANDARD
- ANY DAMAGE TO STEERING WHEEL
 YES NO
- IF YES, EXPLAIN

DO NOT ERASE DRB READINGS

- IS VEHICLE EQUIPPED WITH PASSENGER AIRBAG DEFAULT SWITCH?
 YES NO
- IF YES,
 NOTE POSITION OF PASSENGER A/B SWITCH
 ON OFF N/A
- EVIDENCE OF TAMPERING OR DISASSEMBLY?
 YES NO N/A
- IF YES, EXPLAIN
- CHECK ENTIRE UNDERBODY FOR HIDDEN DAMAGE INCLUDING FRONT AND REAR SUSPENSION COMPONENTS
- UNDERBODY DAMAGED?
 YES NO
- IF YES, EXPLAIN

PHOTOGRAPH REQUIRED

PART D - SEATS/SHOULDER BELTS

REQUIRED PHOTOGRAPHS:

- OVERALL SEAT BELTS I/B & O/B
- CLOSE UP OF ANY IRREGULARITIES
- LATCHPLATE WEAR
- CLOSE UP D-RING TO SHOW LOADING
- OVERALL OF SEAT
- CLOSE UP OF DAMAGE
- RECORD DTC'S:

INFORMATION:

- LOCATE SEAT BELT LABELS AND RECORD ALL INFORMATION (SOME LABELS ARE SEWN TO WEBBING, OTHER LABELS ARE ON THE RETRACTOR FRAME: INBOARD SEAT BELT LABELS ARE NEAR THE FLOOR):
Rt-TRW H01-06,176029R Left TRW H01-07, 174023R
- RECORD ALL INFORMATION STAMPED ON LATCHPLATE
Rt side-- TD085 Left side-TD086
- PRETENSION DEPLOYED?
 YES NO UNKNOWN
- EXISTING LOCATION OF RECLINER - DESCRIBE THE LOCATION AND PICTURE OF SEAT BACK WITH B PILLOR AS REFERENCE AND INCLINOMETER READING
65 degree angle
- EXISTING LOCATION OF HEAD RESTRAINT (MEASURE GAP UNDER HEAD RESTRAINT):

IF ALLOWED. FUNCTION BELTS TO INSURE THEY **FUNCTION PROPERLY**

- NOTE RESULTS
- DOES THE BUCKLE LATCH?
 YES NO
- IF NO, EXPLAIN
- DO THEY RELEASE?
 YES NO
- IF NO, EXPLAIN
- DO THEY RETRACT?
 YES NO
- IF NO, EXPLAIN
- ANY LOOSENESS OR BROKEN PARTS
 YES NO
- IF YES, EXPLAIN?
- CHECK FOR SEAT RETAINING BOLTS
 NORMAL
 BROKEN
 LOOSE
 MISSING
- NOTE AND RECORD APPROX. SEAT TRACK

OVERLAP
0-overlap

PART - E TRANSMISSION NOT APPLICABLE

Previous

Next

PART - F UNINTENDED ACCELERATION NOT APPLICABLE

PART - G BRAKES NOT APPLICABLE

PART - H STEERING/SUSPENSION/TIRES NOT APPLICABLE

PART - I AXLE/DIFFERENTIAL NOT APPLICABLE

PART J - ADDITIONAL COMMENTS (DO NOT DRAW ANY CONCLUSIONS)

The vehicle does not show any damage to the exterior, interior or undercarriage. Both left and right passenger airbags are deployed. A copy of the repairs to the vehicle on 10/23/03 (collision damage) shows front end damage and repair for a total of \$7,527.73. The air bags did not deploy or were not listed in repairs.

Previous

Form Approved

Returned for corrections

From: [REDACTED]
To: customerassist@daimlerchrysler.com
Date: Fri Sep 10 18:16:00 EDT 2004
Subject: Reply to DaimlerChrysler (KMM1890167C0KM)
Reply Comments:

Reference Number: [REDACTED]

Your response indicated that I talked to someone at DaimlerChrysler by phone. I've only spoken to the service department at Overland Park Jeep. As of today, I haven't heard the status of my Jeep Liberty. However, I've been informed that a report has been sent in and that I will be contacted by Chrysler.

[REDACTED]

From: customerassist@daimlerchrysler.com
To: [REDACTED]
Date: Fri Sep 10 09:30:20 EDT 2004
Subject: Re: DaimlerChrysler Customer Assistance
Dear Rochelle,

Thank you for your email to DaimlerChrysler Motors Corporation regarding the
airbag concern you stated you had with your Jeep Liberty.

Our records show that you have contacted us by telephone and we have addressed
your concern. We have updated your file to reflect the latest information you
provided in the email message.

If your concerns have not been addressed, or you have other concerns, please
email or contact the DaimlerChrysler Customer Assistance Center by telephone at
1-800-992-1997, 8:00 a.m. to 5:00 p.m., Monday through Friday.

Thank you again for your email.

NOTE: Please do not use the 'Reply' function of your email system. If you have a
need to respond to this message, please visit us at our reply form (link
provided below). Our system is NOT able to accept any emails at this address.

For any future communications related to this email, please refer to the
following information:

REFERENCE NUMBER: [REDACTED]

REPLY LINK:

http://www.chrysler.com/wccsapp/wccs/brand_forms/us/reply.jsp?trk_ID=KMM18901 [REDACTED]

Sincerely,

Kristen
Senior Staff Representative
DaimlerChrysler Customer Assistance Center

Original Message Follows:

Form Selected:

Category: Recall Information

Brief Description:

The airbags on my 2002 Jeep Liberty deployed.

Comments:

My Jeep Liberty had not been hit nor did I hit anything. I had just left
work. Drove about one block and a half when I noticed the airbag indicator
light on. By the time I reached the stop sign the airbags deployed. This
happened on Monday, August 30, 2004. Have you had this problem with other
2002 Jeep Liberties?

Sender Information:

Title: [REDACTED]
First Name: [REDACTED]

Middle Initial:
Last Name:

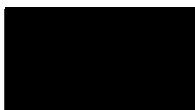

From: [REDACTED]
To: customerassistre@daimlerchrysler.com
Date: Mon Sep 06 16:02:42 EDT 2004
Subject: DaimlerChrysler Customer Assistance
Form Selected:

Category: Recall Information
Brief Description:

The airbags on my 2002 Jeep Liberty deployed.

Comments:

My Jeep Liberty had not been hit nor did I hit anything. I had just left work. Drove about one block and a half when I noticed the airbag indicator light on. By the time I reached the stop sign the airbags deployed. This happened on Monday, August 30, 2004. Have you had this problem with other 2002 Jeep Liberties?

Sender Information:

Title: [REDACTED]
First Name: [REDACTED]
Middle Initial: [REDACTED]
Last Name: [REDACTED]