

EA11-002

VOLKSWAGEN

9-26-2011

EXHIBIT TO REQUEST 7
REQUEST NUMBER SEVEN

Action	Document Name	Make	Model	Model Year
WG Campaign	WG Campaign Circular (US) May 2003	Volkswagen	New Beetle, GTI, Jetta, Passat, EuroVan	2001-2003
	WG Campaign Circular (US) REVISED Dec 2003			
	WG Campaign Circular (US) REVISED Jan 2004			
	WG Campaign Circular (US) REVISED April 2004			
	WG Campaign Circular (US) REVISED June 2004			
	Warranty Service Circular - WG Service Action Loaner Provision			
	Warranty Service Circular - 2001-2003 VW models with Engine Code-Ignition Replacement March 7-03			
	Warranty Service Circular - 2001-2003 VW models with Engine Code-Ignition Replacement May 2-03			
	Warranty Service Circular - Ignition Coil Replacement Feb 11-03			
	Warranty Service Circular - Ignition Coil Replacement Jan 30-03			
	Warranty Service Circular - Ignition coil replacement-Service Circular Nov 13-02			
	Warranty Service Circular - WG Service Action Claim Adjustment Process			
	April 2004 WG Customer Letters US 49 STATES			
	April 2004 WG Customer Letters US CALIFORNIA			
	April 2004 WG Dealer Letter USA			
	January 2004 WG Dealer Letter I US			
	September WG Dealer Letter VR6 Manual US			
	Nov 03 Renotification WG Customer 49 States US			
	Nov 03 Renotification WG Customer California US			
	P1 Campaign			
28F3 P1 emissions circular oct28 2009				
28F3 P1 emissions circular #2 nov2009				
28F3 P1 emissions circular #3 dec2009				
28F3 P1 emissions circular #3 dec15 2009				
28F3 P1 emissions circular #4 jan 2010				
28F3 P1 emissions circular #5 feb2010				
28F3 P1 emissions circular #5 feb 15 2010				
28F3 P1 emissions circular #6 mar2010				
28F3 P1 emissions circular #7 april2010				
28F3 P1 emissions circular #8 may2010				
28F3 P1 emissions circular #9 july2010				
28F3 P1 emissions circular final aug2010				
Customer Letter 28F3 P1_VB2 49S				
Customer Letter 28F3 P1_VB2 CAL				
Customer Letter Upcoming 28F3 P1_VA USA oct 2009				
28F3 P1 August 2010 Wave Dealer Letter USA				
28F3 P1 July 2010 Wave Dealer Letter USA				
28F3 P1 Upcoming Dealer Announcement USA				
28F3 P1 Wave 2 Dealer Announcement				
28F3 P1 Wave 3 Dealer Announcement parts update 12 2009				
28F3 P1 Wave 4 Dealer Announcement 01 2010				
28F3 P1 Wave 5 Dealer Letter USA 02 2010				
28F3 P1 Wave 6 Dealer Letter 03 2010 USA				
28F3 P1 Wave 7 Dealer Letter USA 04 2010				
28F3 P1 Wave 8 Dealer Letter 05 2010 USA				
dealer flier_28F3-P1				
Dealer FAQ_28F3_P1 campaign				
Dealer FAQ_28F3_P1 11 2009				
Customer FAQ_28F3_P1 campaign				
COIL FAQs for Helpline				
28F3 P1 VW USA English Reimbursement Overlay				
P1 - 28F4 Recall Reimbursement Guidelines _coils_ rev. 111209				
Email Communication	Copy of Presentation to the EPA	Volkswagen Audi	All	2001-2007
Presentation	Ignition Coils EPA Follow Up presentation 11-09			

EA11-002

VOLKSWAGEN

9-26-2011

EXHIBIT TO REQUEST 7
REQUEST NUMBER SEVEN
DATA

Email Copy to NHTSA

11182009

Sandvig, Chris

From: Sandvig, Chris
Sent: Wednesday, November 18, 2009 10:40 PM
To: 'Larry.Long@dot.gov'
Subject: Copy of Presentation to the EPA
Attachments: Ignition Coils EPA Follow Up presentation 11-09.pdf

Greetings Larry,

Per our conversation, I have attached the presentation to the EPA regarding the emission service action campaign. It includes a breakdown of the affected vehicles. The presentation is marked confidential and please note that the campaign actually launched on October 23rd because of parts availability.

Regards,

Christopher T. Sandvig

General Manager - Compliance/TREAD

Service & Quality

Volkswagen Group of America, Inc.

Telephone: (248) 754-5563

Fax: (248) 754-5093

e-mail: chris.sandvig@vw.com <<mailto:chris.sandvig@vw.com>>

This message and all attachments are considered confidential. It is intended for use only by the person to whom it is addressed. If you have received this in error, please notify the sender immediately by e-mail and delete all copies of the message. Thank you for your cooperation.

EA11-002

VOLKSWAGEN

9-26-2011

EXHIBIT TO REQUEST 7
REQUEST NUMBER SEVEN
DATA

Ignition Coils EPA Follow Up
presentation 11-09

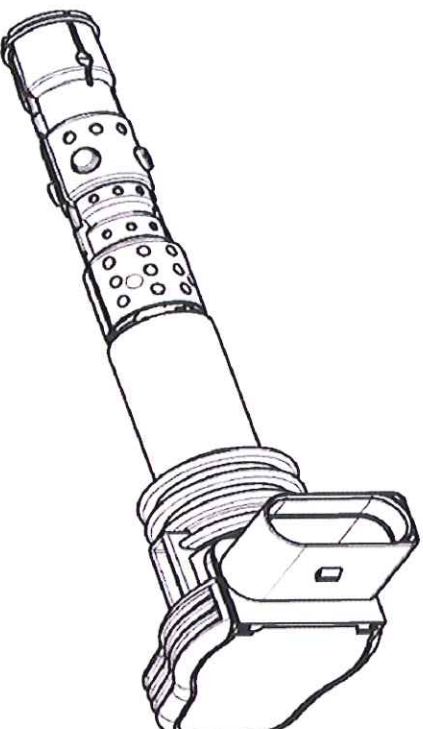

EPA / VWGOA Follow-Up Meeting
Voluntary Emissions Service Action
Ignition Coils – US Market
MY: 2001 to 2007 (VW and Audi)

June 29, 2009 Environmental Protection Agency – Ann Arbor

June 26, 2009

Engineering & Environmental Office

Proposal:
**Voluntary (Emissions) Service Action with Customer
Notification**
Integrated Ignition Coils – MY 2001 to 2007

Topics:

- **VWGoA Voluntary Service Action**
- **Technical Issue**
- **Scope of Vehicles Involved**
- **Timeline / Customer Notification**
- **Parts Availability**
- **Questions / Open Points**

WVG0A Service Action

Volkswagen Group of America is planning a Voluntary Emissions Related Service Action to replace (Generation I) ignition coils installed in specific MY 2001 to 2007 Volkswagen / Audi and Bentley vehicles produced for the US and Canadian market.

The upgrade to the new (Generation II) ignition coils will vastly improve customer satisfaction.

- **Total vehicles involved: 1,524,000 (*)**
- Volkswagen: 1,000,000 (*)
- Audi: 515,000 (*)
- Bentley: 9,000 (*)

Note: (*) = Approximate vehicle population

Technical Issue

- **Customer Complaints:**
 - MIL On with DTC Codes for misfire (Misfire faults are not ignition coil specific)
 - P 0300 (random misfire)
 - P 0301 – P 0312 (individual cylinder misfire)
- **Parts Analysis:**
 - Analysis of sample parts shows that Generation I ignition coils may have internal electrical problems.
- **Scope of Parts Involved in action:**
 - There are 2 distinct vendors for involved (Generation I) ignition coils in service:
 - Bremi/Era/Pulse
 - Eldor
 - Volkswagen and Audi production was changed to (Generation II) ignition coils:
 - Vendor Pulse (replaced Bremi/Era)
 - Vendor Eldor

Scope of Vehicles Involved

The following vehicles (with approximate populations) were produced with (Generation I) ignition coils and will be involved in this Voluntary Service Action:

- **MY: 2001-2006 Volkswagen and Audi – 1.8L Turbo (Population: 678,000)**
 - Volkswagen New Beetle / Jetta / Golf / Passat
 - Audi A4 / A4 Cabrio / Audi TT
- **MY: 2005-2007 Volkswagen and Audi – 2.0L TFSI (Population: 236,000)**
 - Volkswagen EOS / GTI / Jeta / Passat
 - Audi A4 / Audi A3
- **MY: 2004-2006 Volkswagen and Audi – 3.2L VR6 (Population: 51,000)**
 - Volkswagen EOS / Touareg / R32
 - Audi TT (3.2L)
- **MY: 2006-2007 Volkswagen and Audi – 3.6L VR6 (Population 33,400)**
 - Volkswagen Passat / Touareg
 - Audi Q7

Scope of Vehicles Involved (continued)

- **MY: 2004-2007 Volkswagen and Audi – 6.0L W12 (Total Population: 9,950)**
 - Volkswagen Phaeton
 - Audi A8L
 - Bentley (Population approximately 9,000 vehicles)
- **MY: 2004-2006 Volkswagen and Audi – 4.2L V8 (Population: 70,165)**
 - Volkswagen Touareg / Phaeton
 - Audi S4 / A6 / RS4 / A8 / Q7
- **MY: 2006-2007 Volkswagen – 2.5L 5 Cyl. (Population: 246,100)**
 - New Beetle / Golf / Jetta
- **MY: 2002-2004 Volkswagen – 4.0L W8 (Population: 4,940)**
 - Volkswagen Passat
- **MY: 2007 Audi – 5.2L V10 (Population: 1,850)**
 - Audi S6 / S8
- **MY: 2003-2005 Audi – 2.7T V6 (Population: 25,340)**
 - Audi A6 / allroad
- **MY: 2002-2006 Audi – 3.0L V6 (Population: 79,400)**
 - Audi A4 / A6
- **MY: 2005-2007 Audi – 3.1L V6 (Population: 43,600)**
 - Audi A4 / A6

Note:
Emissions Defect Reports have been previously submitted to EPA for all related test groups involved in this proposed Service Action

Timeline / Customer Notification

Due to the scope and complexity of this Service Action, Volkswagen Group of America plans to launch this action with a staggered approach over a 13 month time period, as follows:

- **Step I:** Inform the entire Volkswagen and Audi Dealer Network (August 2009) of the scope and the timeframe of this action, with enough details to answer customer questions as they arise.
- **Step II:** Inform some 1.8T customers (September 2009) in a first wave of notification, that their vehicles will be eligible for immediate replacement of ignition coils under this Service Action

At the same time, Pro-Actively contact the remaining customers and inform them that their vehicles will be involved in an upcoming Service Action. This initial customer letter will describe the following:

Timeline / Customer Notification (Continued)

This initial customer letter will describe the following:

- All ignition coils on customer vehicles will be upgraded to Generation II ignition coils when parts are available
- Customers will receive a future letter describing when they can bring their vehicle to workshop. (Launch of action is staggered over a 13 month time period)
- If their vehicle's MIL light comes on (prior to receiving 2nd notification letter) take vehicle to dealer for diagnosis and dealer will check vehicle's OBD system and replace all ignition coils if proper DTCs are evident (free of charge)
- Step III: Customer Reimbursement program begins for out of pocket expenses of past ignition coil replacements (Dealer / customer informed in 1st letter)
- Step IV: Continue with planned timeline to inform additional customers with a second letter(November 2009) they can now contact dealer to schedule installation of new Generation II ignition coils, per this Service Action
(Workshop capacity is critical and could alter customer notification schedule if early dealer service capacity becomes an issue.)

Parts Availability

Due to the scope of this proposed action and the number of vehicles / replacement parts involved, several factors also had to be considered to assure parts availability for the launch of this Service Action:

- Generation II coils are currently used in production causing production capacity limits at vendors for replacement parts.
- Three vendors are involved in producing Generation II ignition coils
 - Eldor
 - Pulse
 - Bosch
- Service parts will be released to US market using a staggered release by vehicle/engine type

June 26, 2009

Engineering & Environmental Office

Parts Availability / Customer Notification Timeline

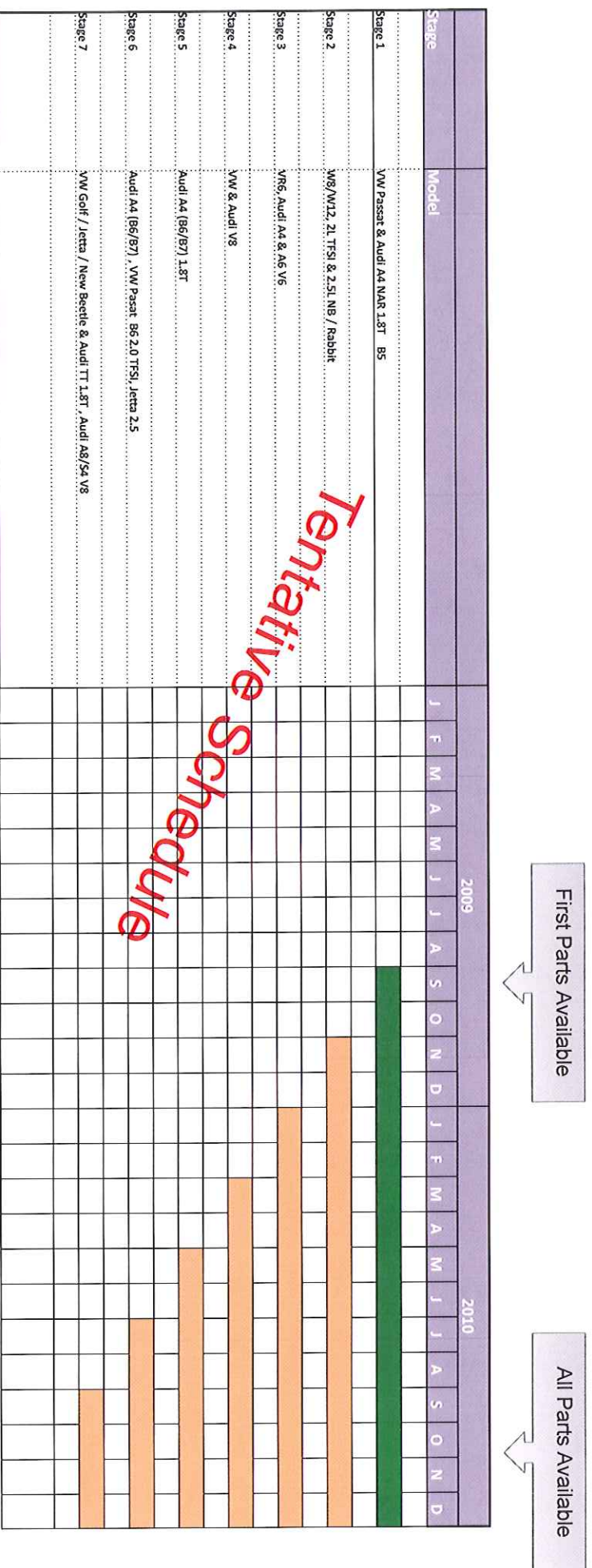

Note: Dealer workshop capacity may be significantly affected by increased volume of repairs caused by this Service Action. Adjustments may be required in timeline to meet dealer workshop requirements!

Simulated Demand Curve:

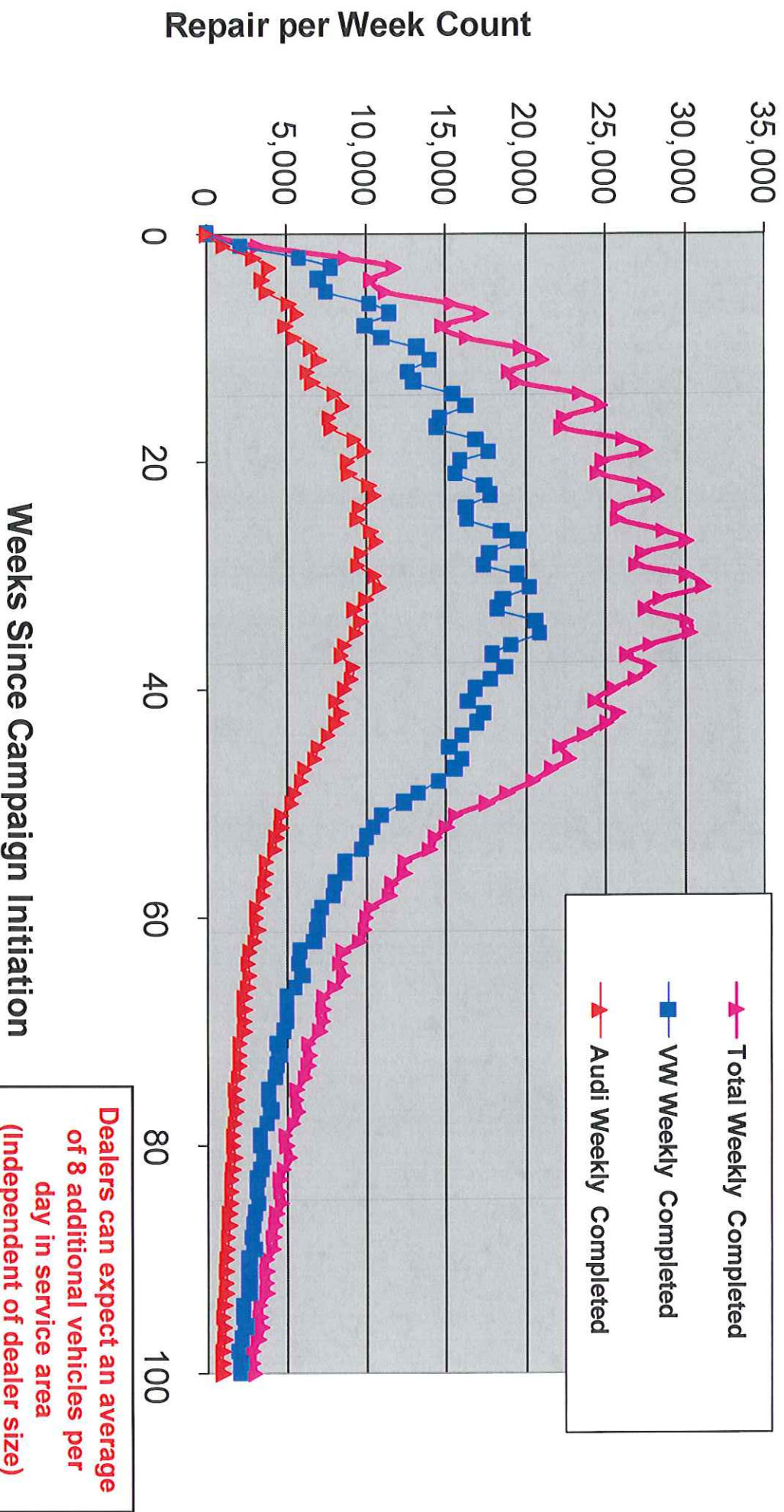

Questions / Open Points:

June 26, 2009

Engineering & Environmental Office

EA11-002

VOLKSWAGEN

9-26-2011

EXHIBIT TO REQUEST 7
REQUEST NUMBER SEVEN
DATA

WG Campaign

Volkswagen of America, Inc.



3800 Hamlin Road
Auburn Hills, MI 48326

Dear

We are now accelerating the process of replacing all ignition coils in cars potentially affected, whether a malfunction has occurred or not. We are writing to you today to invite you to return to your Volkswagen dealer to have your vehicle updated.

If an ignition coil becomes inoperative, the engine and its electronic controls are designed to keep your vehicle running. Your Malfunction Indicator Lamp (MIL) will illuminate and you may experience some deterioration in performance. This condition may also affect the emissions of your vehicle. You can continue driving and should take your car to the nearest Volkswagen dealer for repair.

The update to your vehicle will take less than one hour. Please call the service department of your Volkswagen dealer to schedule an appointment.

If you are the lessor **and registered owner of the vehicle identified in this action, please forward this information immediately by first class mail to the lessee.**

If you have already incurred out-of-pocket expenses, please write us at the address below, and we'll be happy to reimburse you. Please include any receipts you might have along with your letter.

Volkswagen of America, Inc.
Attn: Customer Relations
3499 Hamlin Road
Rochester Hills, MI 48309

I want to emphasize that taking care of you, our customer, remains our highest priority and we thank you for your patience. If you have any further questions, or require assistance locating a Volkswagen dealer, please visit vw.com or call us directly at (800) 822-8987.

Thank you for your continued loyalty.

Sincerely,

A handwritten signature in black ink, appearing to read 'Len Hunt'.

Len Hunt
Vice President
Volkswagen of America, Inc.

Volkswagen of America, Inc.



3800 Hamlin Road
Auburn Hills, MI 48326

Dear

We are now accelerating the process of replacing all ignition coils in cars potentially affected, whether a malfunction has occurred or not. We are writing to you today to invite you to return to your Volkswagen dealer to have your vehicle updated.

If an ignition coil becomes inoperative, the engine and its electronic controls are designed to keep your vehicle running. Your Malfunction Indicator Lamp (MIL) will illuminate and you may experience some deterioration in performance. This condition may also affect the emissions of your vehicle. You can continue driving and should take your car to the nearest Volkswagen dealer for repair.

The update to your vehicle will take less than one hour. Please call the service department of your Volkswagen dealer to schedule an appointment.

*California regulations require that this repair be completed prior to the time that you renew your vehicle registration. **Please make sure that this repair is completed prior to the renewal of your vehicle registration** and that you furnish proof of repair to the DMV in the form of a copy of the dealer's repair order including a signed "Emission Campaign Performance Authorization" which is enclosed with this letter. Please retain the signed certification form with your vehicle records. DO NOT MAIL THIS FORM to the Department of Motor Vehicles (DMV) unless requested.*

If you are the lessor and registered owner of the vehicle identified in this action, please forward this information immediately by first class mail to the lessee.

If you have already incurred out-of-pocket expenses, please write us at the address below, and we'll be happy to reimburse you. Please include any receipts you might have along with your letter.

Volkswagen of America, Inc.
Attn: Customer Relations
3499 Hamlin Road
Rochester Hills, MI 48309

I want to emphasize that taking care of you, our customer, remains our highest priority and we thank you for your patience. If you have any further questions, or require assistance locating a Volkswagen dealer, please visit vw.com or call us directly at (800) 822-8987.

Thank you for your continued loyalty.

Sincerely,

A handwritten signature in black ink, appearing to read 'Len Hunt'.

Len Hunt
Vice President
Volkswagen of America, Inc.

Volkswagen of America, Inc.



3800 Hamlin Rd.
Auburn Hills, MI 48326

April 2004

Dear Volkswagen Dealer:

I am writing to inform you that Volkswagen has begun mailing letters to customers of 2001 – 2003 EuroVan V6 vehicles regarding the ignition coil Service Action of which we had previously informed you.

We have asked the customers to contact your service department to schedule an appointment for this upgrade. Each dealer will receive a computer printout listing containing VINs and owner information of owners which have been notified.

Ignition coil parts will be allocated in conjunction with the customer mailing. If you have any questions about parts allocation or need assistance, please contact your regional After Sales Manager.

Additionally, please refer to Technical Bulletin v190402 for the correct method of putting the radiator in service position.

In conclusion, I want to again thank you for your continued support. I know that this has been a challenging time for your dealership and we appreciate your efforts to keep our mutual customers loyal to our brand.

Regards,

A handwritten signature in cursive script that reads "Maria Cotter".

Maria Cotter
Product Compliance

Volkswagen of America, Inc.



3800 Hamlin Road
Auburn Hills, MI 48326

January 6, 2004

Dear Volkswagen Dealer:

This letter is to inform you that the WG Service Action circular has been updated to include additional information on repairing 2003 model year Jetta vehicles with automatic transmissions. We began notifying these owners on or about December 29, 2003.

Please refer to the **revised Service Action Circular WG** posted on web VESIS and the VW Hub for additional information, including a copy of the customer letter. Also, please be sure to share this information with all personnel with campaign-related responsibilities. A printed copy of these documents will also be sent to you shortly.

Thank you for your cooperation and assistance in this important matter.

Regards,

A handwritten signature in black ink that reads "Maria Cotter".

Maria Cotter
Product Compliance

RE-NOTIFICATION

November 2003

Dear Volkswagen Owner:

You may have previously been notified of the action addressed in the attached notification letter; however, our records indicate that your vehicle has not yet been corrected. Please contact your dealer and arrange for an appointment. The repair will, of course, be free of charge.

Volkswagen of America, Inc.

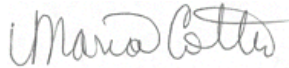

Maria Cotter
Product Compliance

Volkswagen of America, Inc.



3800 Hamlin Road
Auburn Hills, MI
Tel. (248) 754-5000

Dear Volkswagen Owner,

We are now accelerating the process of replacing all ignition coils in cars potentially affected, whether a malfunction has occurred or not. We are writing to you today to invite you to return to your Volkswagen dealer to have your vehicle updated.

If an ignition coil becomes inoperative, the engine and its electronic controls are designed to keep your vehicle running. Your Malfunction Indicator Lamp (MIL) will illuminate and you may experience some deterioration in performance. This condition may also affect the emissions of your vehicle. You can continue driving and should take your car to the nearest Volkswagen dealer for repair.

The update to your vehicle will take less than one hour. Please call the service department of your Volkswagen dealer to schedule an appointment.

If you are the lessor and registered owner of the vehicle identified in this action, please forward this information immediately by first class mail to the lessee.

If you have already incurred out-of-pocket expenses, please write us at the address below, and we'll be happy to reimburse you. Please include any receipts you might have along with your letter.

Volkswagen of America, Inc.
Attn: Customer Relations
3499 Hamlin Road
Rochester Hills, MI 48309

I want to emphasize that taking care of you, our customer, remains our highest priority and we thank you for your patience. If you have any further questions, or require assistance locating a Volkswagen dealer, please visit vw.com or call us directly at (800) 822-8987.

Thank you for your continued loyalty.

Sincerely,



Vice President
Volkswagen of America, Inc.

RE-NOTIFICATION

November 2003

Dear Volkswagen Owner:

You may have previously been notified of the action addressed in the attached notification letter; however, our records indicate that your vehicle has not yet been corrected. Please contact your dealer and arrange for an appointment. The repair will, of course, be free of charge.

Volkswagen of America, Inc.



Maria Cotter
Product Compliance

Volkswagen of America, Inc.



3800 Hamlin Road
Auburn Hills, MI
Tel. (248) 754-5000

Dear Volkswagen Owner,

We are now accelerating the process of replacing all ignition coils in cars potentially affected, whether a malfunction has occurred or not. We are writing to you today to invite you to return to your Volkswagen dealer to have your vehicle updated.

If an ignition coil becomes inoperative, the engine and its electronic controls are designed to keep your vehicle running. Your Malfunction Indicator Lamp (MIL) will illuminate and you may experience some deterioration in performance. This condition may also affect the emissions of your vehicle. You can continue driving and should take your car to the nearest Volkswagen dealer for repair.

The update to your vehicle will take less than one hour. Please call the service department of your Volkswagen dealer to schedule an appointment.

*California regulations require that this repair be completed prior to the time that you renew your vehicle registration. **Please make sure that this repair is completed prior to the renewal of your vehicle registration** and that you furnish proof of repair to the DMV in the form of a copy of the dealer's repair order including a signed "Emission Campaign Performance Authorization" which is enclosed with this letter. Please retain the signed certification form with your vehicle records. **DO NOT MAIL THIS FORM to the Department of Motor Vehicles (DMV), unless requested.***

If you are the lessor and registered owner of the vehicle identified in this action, please forward this information immediately by first class mail to the lessee.

If you have already incurred out-of-pocket expenses, please write us at the address below, and we'll be happy to reimburse you. Please include any receipts you might have along with your letter.

Volkswagen of America, Inc.
Attn: Customer Relations
3499 Hamlin Road
Rochester Hills, MI 48309

I want to emphasize that taking care of you, our customer, remains our highest priority and we thank you for your patience. If you have any further questions, or require assistance locating a Volkswagen dealer, please visit vw.com or call us directly at (800) 822-8987.

Thank you for your continued loyalty.

Sincerely,



Vice President
Volkswagen of America, Inc.

Volkswagen of America, Inc.



3800 Hamlin Road
Auburn Hills, MI 48326

September 2003

Dear Volkswagen Dealer:

I am writing to inform you that Volkswagen has begun mailing letters to customers of 2002 – 2003 GTI and Jetta VR6 manual transmission vehicles regarding the ignition coil Service Action of which we had previously informed you.

These 2002 – 2003 GTI and Jetta VR6 manual transmission vehicles have the letter “H” in the 5th position of the VIN, and can be identified by model 9B __ W6 or 9M __ W6.

At this time, 2002 – 2003 GTI and Jetta VR6 vehicles with automatic transmissions are not being notified.

We have asked the customers to contact your service department to schedule an appointment for this upgrade. We will provide you with a list of your customers as we contact them.

Ignition coil parts will be allocated in conjunction with the customer mailing. If you have any questions about parts allocation or need assistance, please contact your regional After Sales Manager.

In conclusion, I want to again thank you for your continued support. I know that this has been a challenging time for your dealership and we appreciate your efforts to keep our mutual customers loyal to our brand.

Regards,

A handwritten signature in cursive script that reads "Maria Cotter".

Maria Cotter
Product Compliance



Service Circular

Warranty

Subject: Ignition Coil Replacement
(Supersedes VWA-03-03)

Number: VWA-03-04
Date: Feb. 11, 2003

Volkswagen is presently experiencing a temporary shortfall of ignition coil parts, which may adversely impact customer satisfaction regarding ignition coil repairs. As ignition coil parts availability increases for these models, customer satisfaction initiatives will be implemented to address these concerns. The first in this series of initiatives is outlined below. As parts availability continues to improve for other models, you will be notified via additional warranty service circulars.

1.8L Volkswagen Vehicles ONLY – Part Number 06B905115J

- As of January 31, 2003 date of repair, the following customer satisfaction initiative is available if a customer is required to visit the dealership a second time for an ignition coil failure on the same vehicle. This initiative is only applicable to 1.8L Volkswagen vehicles that require ignition coil part number 06B905115J. Replacement ignition coils are to be ordered from the Critical Parts Ignition Coil Team via FAX only. The cover sheet on page 2 of this circular must be completed and faxed along with the required documentation.

Ignition Coil - First Repair Visit

- Replace only the failed ignition coil(s) under warranty. All warranty claims must be substantiated by a VAS 5051/VAS 5052 printout showing Measuring Value Blocks 14, 15 and 16.

Ignition Coil - Second Repair Visit

- If an additional coil fails on a 1.8L Volkswagen vehicle, resulting in the customer's second coil repair visit to a dealership, the customer will then be eligible to have the defective coil(s) replaced, as well as the remaining non-defective coils (excluding previously replaced coils on the customer's first repair visit unless the coils are defective). The following information/documentation is required for program eligibility.
 - Repair Order Number from 1st visit (if 1st repair completed by the same dealership)
 - Copy of current Repair Order (second/subsequent visit)
 - VAS 5051/5052 Printout with **MVB 14, 15 and 16** (Second/subsequent repair must show at least one failed coil)

Please see page 2 of this circular for the ignition coil parts ordering process. If you have any questions, please contact your Critical Parts Ignition Coil team representative listed below.

Chicago PDC	Trish Hensley	248-754-4446	patricia.hensley@vw.com
Jacksonville PDC	Heather Morris	248-754-4440	heather.morris@vw.com
Cranbury PDC	Patty Soave	248-754-6304	patty.soave@vw.com
Fort Worth PDC	Heather Morris	248-754-4440	heather.morris@vw.com
Ontario, CA PDC	Rhonda Wages	248-754-4483	rhonda.wages@vw.com
Ajax and Vancouver PDC	Tracey Wilcox	248-754-6788	tracey.wilcox@vw.com
Team Leader	Mary Jo Farley	248-754-5762	maryjo.farley@vw.com
North American Team Leader	Robert Hirsch	248-754-4631	robert.hirsch@vw.com



Service Circular

Warranty

Subject: Ignition Coil Replacement
(Supersedes VWA-03-03)

Number: VWA-03-04
Date: Feb. 11, 2003

FAX Parts Ordering Process for Part #06B905115J Ignition Coil Replacement

****The FAX number to be utilized is (248) 754-6423, Attn: Ignition Coil Team****

Please use this as a **Cover Sheet** when faxing first *or* second repair requests for the 1.8-liter ignition coil, Part # 06B905115J.

(All information requested below must be complete in order to process your request)

Dealer # _____ Dealer Contact Name _____

Dealer Fax # _____

VIN (Complete) _____

First Repair Visit:

- This Cover Sheet (completed)
- Copy of Repair Order
- VAS 5051/5052 Printout with **MVB 14, 15 and 16**
- Number of coils needed _____ (Only defective coil(s) to be replaced)

Second (or Subsequent) Repair Visit:

- This Cover Sheet (completed)
- Repair Order Number from 1st visit _____
 - Check this box if 1st repair performed at another dealership and repair order is not available.
- Copy of current Repair Order (second/subsequent visit)
- VAS 5051/5052 Printout with **MVB 14, 15 and 16** (must show at least one misfire)
- Remaining number of coils needed _____

If the information faxed is incomplete or further information is required, this form will be faxed back to you with a request for the specific information.

If you receive this form back, please supply the missing information/documentation in order to complete processing.



Service Circular

Warranty

Subject: Ignition Coil Replacement

Number: VWA-03-03

Date: Jan. 30, 2003

Volkswagen is presently experiencing a temporary shortfall of ignition coil parts, which may adversely impact customer satisfaction regarding ignition coil repairs. As ignition coil parts availability increases for these models, customer satisfaction initiatives will be implemented to address these concerns. The first in this series of initiatives is outlined below. As parts availability continues to improve for other models, you will be notified via additional warranty service circulars.

1.8L Volkswagen Vehicles ONLY – Part Number 06B905115J

- As of January 31, 2003 date of repair, the following customer satisfaction initiative is available if a customer is required to visit the dealership a second time for an ignition coil failure on the same vehicle. This initiative is only applicable to 1.8L Volkswagen vehicles that require ignition coil part number 06B905115J.

Ignition Coil - First Repair Visit

- Replace only the failed ignition coil(s) under warranty. All warranty claims must be substantiated by a VAS 5051/VAS 5052 printout showing Measuring Value Blocks 14, 15 and 16.

Ignition Coil - Second Repair Visit

- If an additional coil fails on a 1.8L Volkswagen vehicle, resulting in the customer's second coil repair visit to a dealership, the customer will then be eligible to have the defective coil(s) replaced, as well as the remaining non-defective coils (excluding previously replaced coils on the customer's first repair visit unless the coils are defective). The following additional documentation and ordering requirements are required for program eligibility.
 - The Dealer must provide a copy of the repair documentation from the **first** repair visit, including the VAS 5051/VAS 5052 printout showing Measuring Value Blocks 14, 15 and 16.
 - The warranty claim for the second repair must be substantiated by a VAS 5051/VAS 5052 printout showing Measuring Value Blocks 14, 15 and 16 for at least one failed coil on the second repair.
 - The ignition coil(s), part number 06B905115J, **must** be ordered through the Critical Parts Ignition Coil Team.

Critical Parts Ignition Coil Team Contact Information

To place an ignition coil order, part number 06B905115J, contact a member of the Critical Parts Ignition Coil Team listed below via FAX, phone or email. Please include the VIN and customer's name.

Chicago PDC	Trish Hensley	248-754-4446	patncia.hensley@vw.com
Jacksonville PDC	Tracey Wilcox	248-754-6788	tracey.wilcox@vw.com
Cranbury PDC	Patty Soave	248-754-6304	patty.soave@vw.com
Fort Worth PDC	Heather Morris	248-754-4440	heather.morris@vw.com
Ontario, CA PDC	Rhonda Wages	248-754-4483	rhonda.wages@vw.com
Ajax and Vancouver PDC	Tracey Wilcox	248-754-6788	tracey.wilcox@vw.com
Team Leader	Mary Jo Farley	248-754-5762	maryjo.farley@vw.com
North American Team Leader	Robert Hirsch	248-754-4631	robert.hirsch@vw.com
The FAX number to be utilized for ALL PDC's is 248-754-6423			



Service Circular

Warranty

Subject: WG Service Action Claim Adjustment Process

Number: VWA-03-17

Date: July 11, 2003

As per Service Action Circular Code WG, vehicles already fitted or repaired with improved Ignition Coils do not require a full set replacement (4 or 6) when performing the Service Action.

However, the Dealer reimbursement procedure outlined in the WG circular assumes a full set of replacement Ignition Coils and is automatically priced to reimburse as such. As stated under the WG Data Entry procedure:

“Adjustments will be made on claims where improved coil replacement occurred prior to initiation of the WG Service Action.”

A program has been developed to process this adjustment. The program reviews the Service Action claim submitted and captures the Vehicle Identification Number (VIN) and number of parts charged in the RC claim. The Vehicle's repair history file is then queried and, where improved Ignition Coils have already been fitted to the vehicle in an earlier repair, the quantity of improved parts already fitted is recorded. An adjustment claim is then generated which will debit the number of coils that would not have been replaced during the Service Action repair.

Please note - only the price of the parts will be debited and not the labor.

The Dealer who performed the Service Action will receive a weekly report (by facsimile) on these adjustment claims. This will allow verification before the claims are processed the following week. This report will include the following detail on the earlier/previous repair:

- VIN
- Dealer
- Repair Date
- Claim Number
- Part Number(s) replaced
- Part Quantity replaced

The following week, these adjustment claims will be processed by the Warranty Information Network (WIN) and recorded on the Dealers Audit Trail. The claims will be identified as an RC claim type and the claim number will have a suffix "F".

Please review your weekly report in order to verify the number of Ignition Coils adjusted agrees with your corresponding Service Action Repair Order.

The Warranty Call Center will provide support on any queries.



Service Circular

Warranty

Subject: WG Service Action Loaner Vehicle Provision

Number: VWA-03-15

Date: June 13, 2003

We recognize that in a limited number of instances there might be a need to provide a one-day loaner for repairs performed under the WG Service Action. Volkswagen will reimburse dealers for a one-day loaner for repairs performed under the WG Service Action. Vehicles that are placed into the Volkswagen Service Loaner Program would be best suited for this program. Appropriate documentation must be retained including the loaner rental agreement, the customer name, date, time, and mileage on the loaner vehicle when it goes out, and the date, time, and mileage on the loaner vehicle when it is returned.

As this is a special program only applicable to the WG Service Action, please be certain to use the following claim coding information.

CLAIM TYPE	SP
PART ID	WGLN
LOANER	\$30.00 for a one-day loaner

All amounts are in US dollars, Canadian at current exchange rate.

If you have any questions regarding the warranty claiming process, please call the Volkswagen Warranty Center at 1-866-306-8447.

Volkswagen of America, Inc.



3800 Hamlin Road
Auburn Hills, MI 48326
Tel. (248) 754-5000

May 29, 2003

Dear Volkswagen Dealer:

I am writing to inform you that Volkswagen has begun the ignition coil Service Action of which we had previously informed you. We will now replace all ignition coils in cars potentially affected, whether a malfunction has occurred or not. Enclosed for your information is the WG Service Circular.

To best serve your most affected customers, we have designed a staggered approach. We will send customer letters in "waves" beginning in early June and continuing through December. These waves will be made up of a combination of customers throughout the United States and Canada with an initial concentration on customers driving vehicles that have experienced the higher failure rates.

Attached is a copy of the customer letter. We have asked the customers to make contact with your service department to schedule an appointment for this upgrade. We will provide you with a list of your customers as we contact them.

Ignition coil parts will be allocated in conjunction with the customer mailing. If you have any questions about parts allocation or need assistance, please contact your regional After Sales Manager.

As we go through this process, we ask that you continue to service any customer who requests the update even if he or she has not yet received the letter.

In conclusion, I want to again thank you for your continued support. I know that this has been a challenging time for your dealership and we appreciate your efforts to keep our mutual customers loyal to our brand.

Regards,

A handwritten signature in cursive script that reads "Frank Maguire".

Frank Maguire
Vice President
Volkswagen of America, Inc.



Service Action Circular

Code: **WG**

May 2003

Subject: 2001–2003 Model Year Volkswagen Vehicles Replace Ignition Coils

This is to inform you of the initiation of a service action campaign involving some below identified 2001 through 2003 model year Volkswagen vehicles. This service action pertains to the replacement of the ignition coils.

Problem Description

It is possible that if one of the vehicle's ignition coils fails, rough idling or reduced driving power could occur in addition to illumination of the MIL light.

Remedial Action

Replace ignition coils in each affected vehicle.

Vehicle Identification and VIN Number Ranges

The vehicles affected by this action are identified as follows:

2001 – 2003 New Beetle 1.8T

3VW_ *_ _1C_1M000001 - 3VW_ *_ _1C_3M414843

(* Vehicles with C in 5th position for model year 2001 only) (* Vehicles with D in 5th position for model years 2001-03) (* Vehicles with E in 5th position for model year 2003 only)

2001 – 2003 Golf (GTI) 1.8T, Jetta 1.8T

9BW_ *_ _1J_1P000001 - 9BW_ *_ _1J_34032850

(* Vehicles with D in 5th position for model year 2001 only) (* Vehicles with D or E in 5th position for model year 2002 only) (* Vehicles with E in 5th position for model year 2003)

3VW_ *_ _9M_1M000001 - 3VW_ *_ _9M_3M051297

(* Vehicles with D in 5th position for model year 2001 only) (* Vehicles with D or E in 5th position for model year 2002 only) (* Vehicles with E in 5th position for model year 2003)

WVW_ *_ _1J_2W000001 - WVW_ *_ _1J_3W334992

(* Vehicles with D or E in 5th position for model year 2002 only) (* Vehicles with E in 5th position for model year 2003)

2002 – 2003 GTI V6

9BW_H_1J_24000001 - 9BW_H_1J_34040002

2002 – 2003 Jetta GLI

3VW_H_9M_2M000001 - 3VW_H_9M_3M105131

WVW_H_1J_2W000001 - WVW_H_1J_3W367577

2001 – 2003 Passat 1.8T

WVW_ *_ _3B_1E000001 - WVW_ *_ _3B_3E175002

WVW_ *_ _3B_1P000001 - WVW_ *_ _3B_3P265086

(* Vehicles with C or D in 5th position for model year 2001 only) (* Vehicles with D in 5th position for model years 2002/3)

2002 – 2003 Passat W8

WVW_K_3B_2P000001 - WVW_K_3B_3P263779

WVW_K_3B_2E000001 - WVW_K_3B_3E177001

2001 – 2003 EuroVan V6

WV_ _B_70_1H000519 - WV_ _B_70_3H091264

Important: Please Provide A Copy To All Personnel With Campaign-Related Responsibilities!

Volkswagen of America, Inc.

**Owner
Notification
Mailing**

Volkswagen of America, Inc will inform all known owners of this upcoming service action campaign by first class mail. Because a high number of vehicles are affected for most dealers, we will “stagger” the owner notification mailings. The first mailings will begin on or about June 6, 2003 and continue on a weekly basis until all owners are notified.

Vehicle Allocation

Each dealer will receive a weekly computer printout listing containing VINs and owner information of owners which have been notified that specific week.

**Parts
Information**

You will receive automatic weekly parts allocations based on each week’s owner notification mailings to owners located within your area of responsibility. Do not place an order on your own until further notice.

New Beetle 1.8T - 06B 905 115J/L
Golf(GTI), Jetta 1.8T - 06B 905 115J/L
GTI, Jetta GLI - 022 905 100D/G
Passat 1.8T - 06B 905 115J/L
Passat W8 - 07C 905 115C/D
EuroVan V6 - 022 905 100C/F

Work Procedure

Objective: This procedure describes changing the ignition coils on 1.8 liter & 2.8 liter engines in New Beetle, GTI & Jetta vehicles, 1.8 liter & 4.0 liter engines in Passat vehicles, and on 2.8 liter engines in Eurovan vehicles.

Special Tools

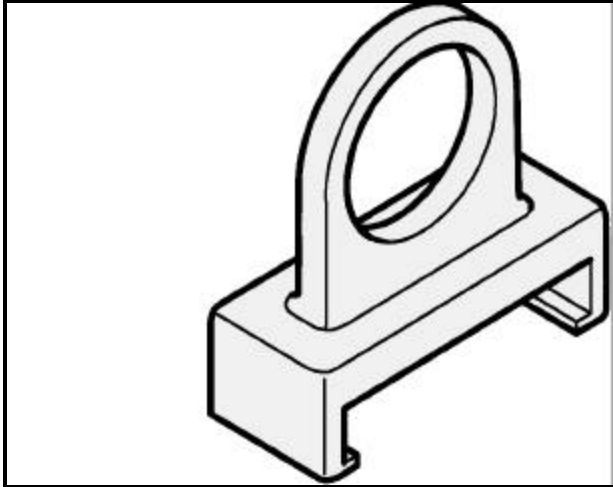

⇐ **Puller T40039** - must be used to avoid damaging ignition coils during removal

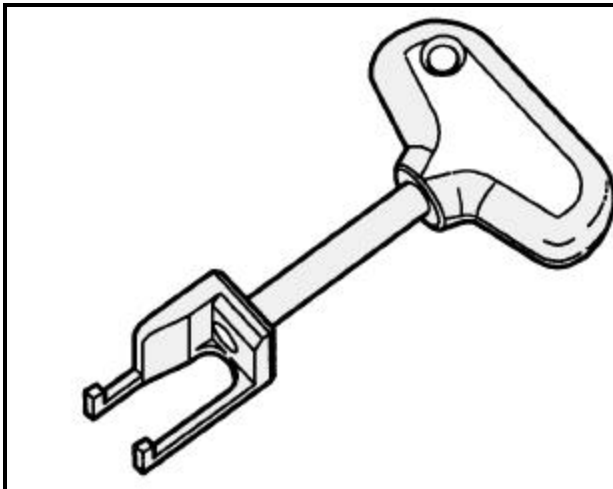

⇐ **Puller T0095** - must be used to avoid damaging ignition coils during removal

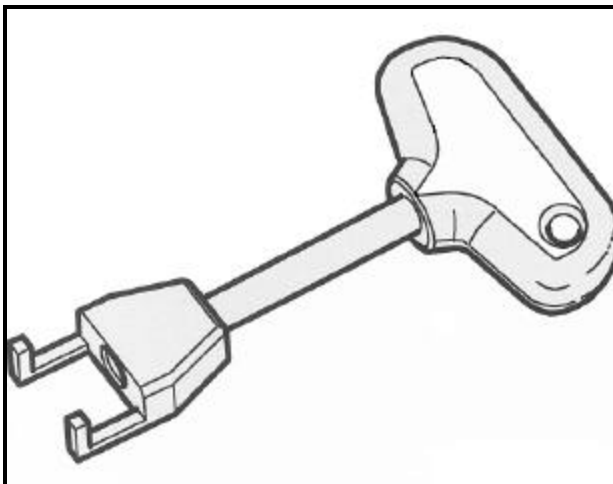

⇐ **Puller T10094** - must be used to avoid damaging ignition coils during removal

Work Sequence:

- Section A - 2.8 liter engine in Jetta and GTI vehicles**
- Section B - 1.8 liter engine in New Beetle, GTI, Jetta and Passat vehicles**
- Section C - 4.0 liter engine in Passat vehicles**
- Section D - 2.8 liter engine in Eurovan vehicles**

Section A – 2.8 Liter Engine in Jetta and GTI

IMPORTANT! If the vehicle has a MIL light on, the diagnostic trouble codes (DTCs) must be checked. Only cylinder misfire DTCs related to ignition coil malfunction are covered by this service action. Any other checking, diagnosis or repairs are not part of or covered under this service action.

- If applicable, connect VAS5051 and check DTCs
- Open hood and remove engine cover

⇐ Disconnect connector from all ignition coils -1-

- Using **Puller T10095**, remove ignition coils

CAUTION: Use of tool T10095 is required to avoid damaging these sensitive components

NOTE: Only ignition coils that are not at the latest production level must be replaced. (Reference "Parts Information" on Page 2/13)

- Install new ignition coils (022 905 100 D/G) by pressing into cylinder head by hand only

IMPORTANT! Do not use any object to tap ignition coil into position. Do not twist ignition coil when installing.

- Reconnect connectors to ignition coils
- Reinstall engine cover and close hood

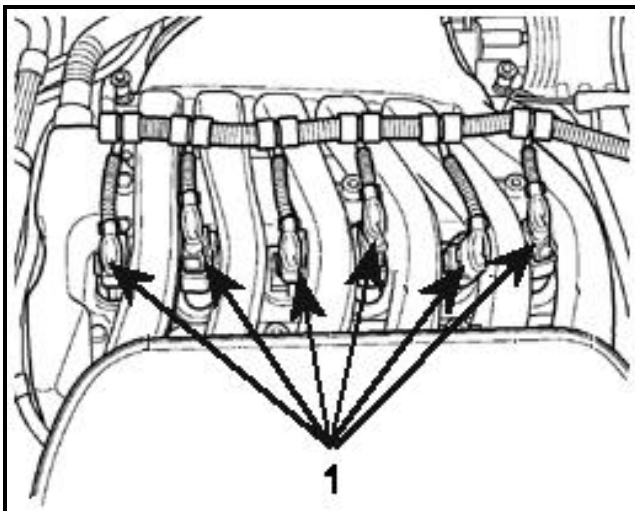

- If the MIL light was on and cylinder misfire DTCs were present, printed and erased, use VAS5051 and set engine readiness code
- Attach a copy of print out for diagnostic log (showing cylinder misfire DTCs) and readiness code “Test Complete” to repair order

Note: Readiness code setting is not related to this action when other components related to the MIL light are diagnosed and repaired

- ***Destroy and properly dispose of removed ignition coils***

Section B – 1.8 Liter Engine in New Beetle, GTI, Jetta and Passat

IMPORTANT! If the vehicle has a MIL light on, the diagnostic trouble codes (DTCs) must be checked. Only cylinder misfire DTCs related to ignition coil malfunction are covered by this service action. Any other checking, diagnosis or repairs are not part of or covered under this service action.

- If applicable, connect VAS5051 and check DTCs
- Open hood and remove engine cover
- If applicable, remove screw securing vacuum reservoir located above ignition coils
- On New Beetle vehicles, remove plate with turbo boost valve and move aside

Note: Vacuum lines to reservoir and turbo boost valve do not have to be disconnected

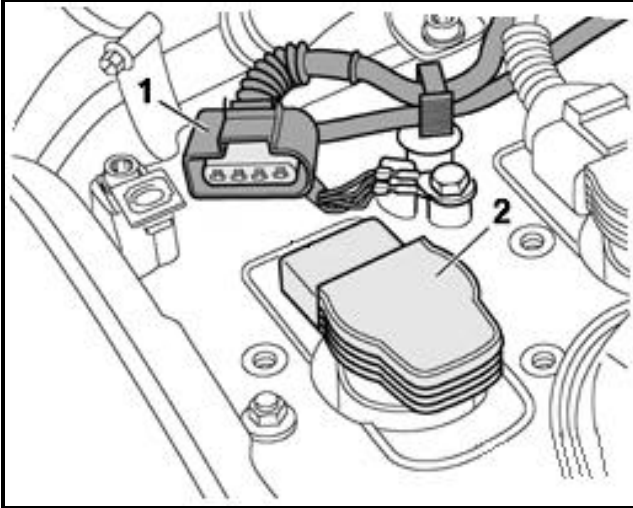

⇐ Disconnect connectors -1- from all ignition coils -2-

NOTE: Only ignition coils that are **not** at the latest production level must be replaced. (Reference "Parts Information" on Page 2/13)

- Using **Puller T40039**, remove ignition coils

CAUTION: Use of tool T40039 is required to avoid damaging these sensitive components

- Install new ignition coils (06B 905 115J/L) by pressing into cylinder head with hand only

IMPORTANT! Do not use any object to tap ignition coil into position. Do not twist ignition coil when installing.

- Reconnect connectors to ignition coils
- If applicable, reinstall plate with turbo boost valve
- Reinstall vacuum reservoir and secure with bolt
- Reinstall engine cover and close hood
- If the MIL light was on and cylinder misfire DTCs were present, printed and erased, use VAS5051 and set engine readiness code
- Attach a copy of print out for diagnostic log (showing cylinder misfire DTCs) and readiness code "Test Complete" to repair order

Note: Readiness code setting is not related to this action when other components related to the MIL light are diagnosed and repaired

- ***Destroy and properly dispose of removed ignition coils***

Section C – 4.0 Liter Engine in Passat

IMPORTANT! If the vehicle has a MIL light on, the diagnostic trouble codes (DTCs) must be checked. Only cylinder misfire DTCs related to ignition coil malfunction are covered by this service action. Any other checking, diagnosis or repairs are not part of or covered under this service action.

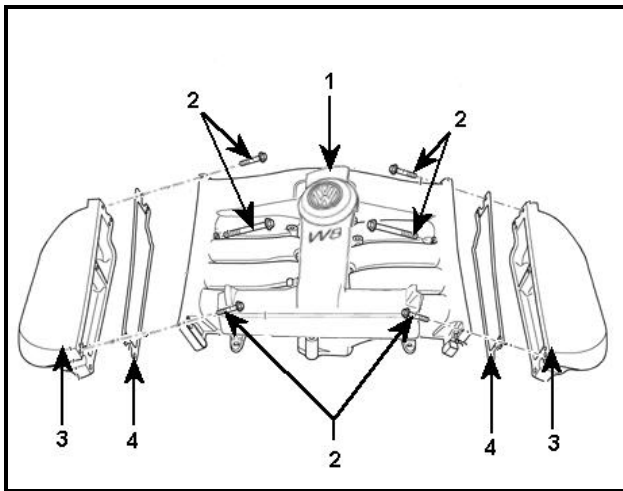

- If applicable, connect VAS5051 and check DTCs

⇐ Open hood and remove center manifold cover -1-

⇐ Remove bolts -2- securing left and right intake manifold side parts -3- and remove side part with gaskets -4-

- Disconnect connectors on all ignition coils

NOTE: Only ignition coils that are not at the latest production level must be replaced. (Reference "Parts Information" on Page 2/13)

- Using **Puller T10094**, remove ignition coils on left and right banks of engine

CAUTION: Use of tool T10094 is required to avoid damaging these sensitive components

- Install new ignition coils (07C 905 115C/D) by pressing into cylinder head by hand only

IMPORTANT! Do not use any object to tap ignition coil into position. Do not twist ignition coil when installing.

- Reconnect connectors to ignition coils

- Reinstall left and right intake manifold side parts with gasket and tighten bolts to 8 Nm. (71 in. lbs.)
- Reinstall center cover and close hood
- If the MIL light was on and cylinder misfire DTCs were present, printed and erased, use VAS5051 and set engine readiness code
- Attach a copy of print out for diagnostic log (showing cylinder misfire DTCs) and readiness code "Test Complete" to repair order

Note: Readiness code setting is not related to this action when other components related to the MIL light are diagnosed and repaired

- ***Destroy and properly dispose of removed ignition coils***

Section D – 2.8 Liter Engine in Eurovan

IMPORTANT! If the vehicle has a MIL light on, the diagnostic trouble codes (DTCs) must be checked. Only cylinder misfire DTCs related to ignition coil malfunction are covered by this service action. Any other checking, diagnosis or repairs are not part of or covered under this service action.

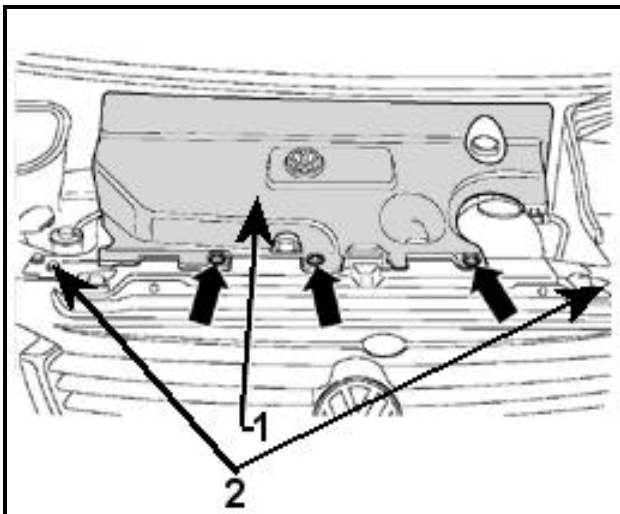

- If applicable, connect VAS5051 and check DTCs
- ⇐ Open hood and remove three T30 torx® screws -arrows- securing engine cover -1- and remove engine cover
- ⇐ Remove bolts -2- on left and right side of vehicle and pivot radiator forward to service position

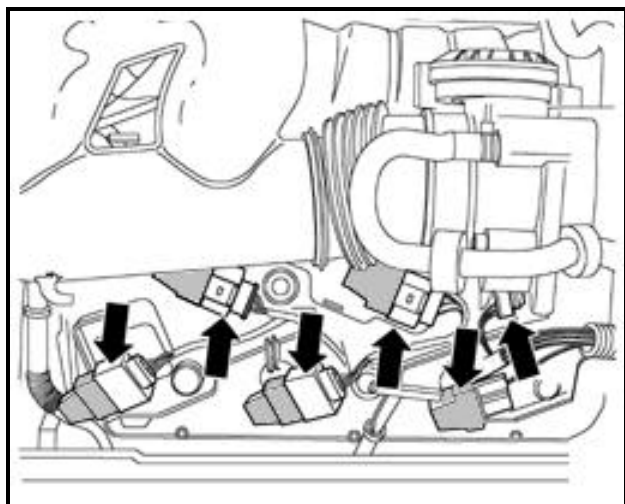

⇐ Disconnect connectors -arrows- from all ignition coils

NOTE: Only ignition coils that are **not** at the latest production level must be replaced. (Reference "Parts Information" on Page 2/13)

⇐ Using **Puller T10095**, remove ignition coils

CAUTION: Use of tool T10095 is required to avoid damaging these sensitive components

- Install new ignition coils (022 905 100C/F) by pressing into cylinder head by hand only

IMPORTANT! Do not use any object to tap ignition coil into position. Do not twist ignition coil when installing.

- Reconnect connectors to ignition coils
- Move radiator rearward and secure in position with bolts and tighten to 10 Nm (88 in. lbs.)
- Reinstall engine cover and secure with T30 Torx® screws
- If the MIL light was on and cylinder misfire DTCs were present, printed and erased, use VAS5051 and set engine readiness code
- Attach a copy of print out for diagnostic log (showing cylinder misfire DTCs) and readiness code "Test Complete" to repair order

Note: Readiness code setting is not related to this action when other components related to the MIL light are diagnosed and repaired

- ***Destroy and properly dispose of removed ignition coils***

**Time Requirements/
Reimbursement**

To ensure prompt reimbursement, be sure to enter, immediately upon replacement of the ignition coils the applicable reimbursement code listed below.

WG Data Entry Procedure

Claim Type	Repair Code (Damage Code Field)	Time Units	Work Scope
RC	WG12	50 T.U.	<u>2.8L Jetta & GTI Vehicles</u> - Replace ignition coils 6 022 905 100D/G Ignition coil
RC	WG13	110 T.U.	<u>2.8L Jetta & GTI Vehicles</u> - Replace ignition coils - Fault Diagnosis and Set Readiness Code 6 022 905 100D/G Ignition coil
RC	WG14	40 T.U.	<u>1.8T New Beetle, Jetta, GTI & Passat Vehicles</u> - Replace ignition coils 4 06B 905 115J/L Ignition coil
RC	WG15	100 T.U.	<u>1.8T New Beetle, Jetta, GTI & Passat Vehicles</u> - Replace ignition coils - Fault Diagnosis and Set Readiness Code 4 06B 905 115J/L Ignition coil
RC	WG16	110 T.U.	<u>4.0L Passat W8 Vehicles</u> - Replace ignition coils 8 07C 905 115C/D Ignition coil
RC	WG17	170 T.U.	<u>4.0L Passat W8 Vehicles</u> - Replace ignition coils - Fault Diagnosis and Set Readiness Code 8 07C 905 115C/D Ignition coil
RC	WG18	50 T.U.	<u>2.8L EuroVan V6 Vehicles</u> - Replace ignition coils 6 022 905 100C/F Ignition coil
RC	WG19	110 T.U.	<u>2.8L EuroVan V6 Vehicles</u> - Replace ignition coils - Fault Diagnosis and Set Readiness Code 6 022 905 100C/F Ignition coil

The system automatically enters the part number and labor applicable to the above listed codes.

Please note that in some instances vehicles repaired prior to this action already have improved coils (reference "Parts Information" on page 2/13) and do not require replacement.

The above reimbursement codes assume all coils were replaced on respective vehicles.

Adjustments will be made on claims where improved coil replacement occurred prior to initiation of the WG Service Action.

For vehicles that, according to your information, cannot be corrected, and one of the codes below best describe the reason, please enter into the system one of the codes indicated, as applicable:

WG 20	Customer Refused Repairs
WG 30	Total Loss
WG 40	Vehicle Stolen
WG 50	Vehicle Exported

California Emission Recall Requirements - (FOR CALIFORNIA DEALERS ONLY)

The California Air Resources Board and the Department of Motor Vehicles (DMV) require that emissions-related recalls be completed prior to vehicle registration renewal. **It is, therefore, imperative that upon completion of this recall work that you provide the owner with a signed "Vehicle Emission Recall – Proof of Correction" certificate.** This certificate, #RC0801 CALEM ALL, will accompany the California owner notification letters. The California Department of Motor Vehicles requires that the size and color of the certificate is identical to the sample provided in this package. Therefore, *if you need additional certificates please order them through Dymont using the above-mentioned order number.*

Service Action**Verification**

Due to the "staggering" of owner notification mailings the OTIS View Campaign inquiry system will not display the **WG** until final mailings are complete.

Service**Help**

If you have any technical questions regarding this service action, please contact the Volkswagen Technicians' Helpline at 1 (800) 678-2389. For any other non-technical questions regarding this or any other action, please contact us by calling **(800) 741-2919**.

Dealer**Personnel****Information**

Please inform and/or provide a copy of this important communication to every person in your dealership who has campaign-related responsibilities, including parts and accounting personnel.

Thank you for your cooperation.



3800 Hamlin Road
Auburn Hills, MI
Tel. (248) 754-5000

California Regulations

Dear Mr. Sample,

We are now accelerating the process of replacing all ignition coils in cars potentially affected, whether a malfunction has occurred or not. We are writing to you today to invite you to return to your Volkswagen dealer to have your vehicle updated.

If an ignition coil becomes inoperative, the engine and its electronic controls are designed to keep your vehicle running. Your Malfunction Indicator Lamp (MIL) will illuminate and you may experience some deterioration in performance. This condition may also affect the emissions of your vehicle. You can continue driving and should take your car to the nearest Volkswagen dealer for repair.

The update to your vehicle will take less than one hour. Please call the service department of your Volkswagen dealer to schedule an appointment.

*California regulations require that this repair be completed prior to the time that you renew your vehicle registration. **Please make sure that this repair is completed prior to the renewal of your vehicle registration** and that you furnish proof of repair to the DMV in the form of a copy of the dealer's repair order including a signed "Emission Campaign Performance Authorization" which is enclosed with this letter. Please retain the signed certification form with your vehicle records. DO NOT MAIL THIS FORM to the Department of Motor Vehicles (DMV), unless requested.*

If you are the lessor and registered owner of the vehicle identified in this action, please forward this information immediately by first class mail to the lessee.

If you have already incurred out-of-pocket expenses, please write us at the address below, and we'll be happy to reimburse you. Please include any receipts you might have along with your letter.

Volkswagen of America, Inc.
Attn: Customer Relations
3499 Hamlin Road
Rochester Hills, MI 48309

I want to emphasize that taking care of you, our customer, remains our highest priority and we thank you for your patience. If you have any further questions, or require assistance locating a Volkswagen dealer, please visit vw.com or call us directly at (800) 822-8987.

Thank you for your continued loyalty.

Sincerely,

Frank Maguire
Vice President
Volkswagen of America, Inc.



3800 Hamlin Road
Auburn Hills, MI 48326
Tel. (248) 754-5000

49 States

Dear Mr. Sample,

We are now accelerating the process of replacing all ignition coils in cars potentially affected, whether a malfunction has occurred or not. We are writing to you today to invite you to return to your Volkswagen dealer to have your vehicle updated.

If an ignition coil becomes inoperative, the engine and its electronic controls are designed to keep your vehicle running. Your Malfunction Indicator Lamp (MIL) will illuminate and you may experience some deterioration in performance. This condition may also affect the emissions of your vehicle. You can continue driving and should take your car to the nearest Volkswagen dealer for repair.

The update to your vehicle will take less than one hour. Please call the service department of your Volkswagen dealer to schedule an appointment.

If you are the lessor and registered owner of the vehicle identified in this action, please forward this information immediately by first class mail to the lessee.

If you have already incurred out-of-pocket expenses, please write us at the address below, and we'll be happy to reimburse you. Please include any receipts you might have along with your letter.

Volkswagen of America, Inc.
Attn: Customer Relations
3499 Hamlin Road
Rochester Hills, MI 48309

I want to emphasize that taking care of you, our customer, remains our highest priority and we thank you for your patience. If you have any further questions, or require assistance locating a Volkswagen dealer, please visit vw.com or call us directly at (800) 822-8987.

Thank you for your continued loyalty.

Sincerely,

Frank Maguire
Vice President
Volkswagen of America, Inc.

**IMPORTANT! Please provide a copy to all personnel with campaign-related responsibilities!
This supercedes the WG Service Action dated January 2004**



Service Action Circular

Code: WG

April 2004

Subject: 2001–2003 Model Year Volkswagen Vehicles Replace Ignition Coils

This is to inform you of the initiation of a service action campaign involving some below identified 2001 through 2003 model year Volkswagen vehicles. This service action pertains to the replacement of the ignition coils.

Problem Description

It is possible that if one of the vehicle's ignition coils fails, rough idling or reduced driving power could occur in addition to illumination of the MIL light.

Remedial Action

Replace ignition coils in each affected vehicle.

Vehicle Identification and VIN Number Ranges

The vehicles affected by this action are identified as follows:

2001 – 2003 New Beetle 1.8T

3VW_ *_1C_1M000001 - 3VW_ *_1C_3M414843

(* Vehicles with C in 5th position for model year 2001 only) (* Vehicles with D in 5th position for model years 2001-03) (* Vehicles with E in 5th position for model year 2003 only)

2002 – 2003 Golf (GTI) 1.8T, Jetta 1.8T

9BW_ *_1J_2_000001 - 9BW_ *_1J_34032850

(*Vehicles with D or E in 5th position for model year 2002 only) (*Vehicles with E in 5th position for model year 2003)

3VW_ *_9M_2M000001 - 3VW_ *_9M_3M051297

(*Vehicles with D or E in 5th position for model year 2002 only) (*Vehicles with E in 5th position for model year 2003)

WVW_ *_1J_2W000001 - WVW_ *_1J_3W334992

(*Vehicles with D or E in 5th position for model year 2002 only) (*Vehicles with E in 5th position for model year 2003)

2002 – 2003 GTI V6

9BW_H_1J_24000001 - 9BW_H_1J_34040002

2002 – 2003 Jetta GLI

3VW_H_9M_2M000001 - 3VW_H_9M_3M105131

WVW_H_1J_2W000001 - WVW_H_1J_3W367577

2001 – 2003 Passat 1.8T

WVW_ *_3B_1E000001 - WVW_ *_3B_3E175002

WVW_ *_3B_1P000001 - WVW_ *_3B_3P265086

(*Vehicles with C or D in 5th position for model year 2001 only) (*Vehicles with D in 5th position for model years 2002/3)

2002 – 2003 Passat W8

WVW_K_3B_2P000001 - WVW_K_3B_3P263779

WVW_K_3B_2E000001 - WVW_K_3B_3E177001

2001 – 2003 EuroVan V6

WV_ _B_70_1H000519 - WV_ _B_70_3H091264

Owner Notification Mailing

Volkswagen began the initial mailings to inform all known owners of this service action campaign by first class mail on or about June 6, 2003.

Vehicle Allocation

Each dealer will receive a computer printout listing containing VINs and owner information of owners which have been notified.

Parts Information

You will receive automatic parts allocations based on owner notification mailings to owners located within your area of responsibility. Do not place an order on your own until further notice.

<i>New Beetle 1.8T</i>	-	<i>06B 905 115J/L</i>
<i>Golf(GTI), Jetta 1.8T</i>	-	<i>06B 905 115J/L</i>
<i>GTI, Jetta GLI</i>	-	<i>022 905 100D/G</i>
<i>Passat 1.8T</i>	-	<i>06B 905 115J/L</i>
<i>Passat W8</i>	-	<i>07C 905 115C/D</i>
<i>EuroVan V6</i>	-	<i>022 905 100C/F</i>

Work Procedure

Objective: This procedure describes changing the ignition coils on 1.8 liter & 2.8 liter engines in New Beetle, GTI & Jetta vehicles, a wire harness modification for 2002 & 2003 Jetta vehicles having a 2.8 liter engine with an automatic transmission, changing the ignition coils on 1.8 liter & 4.0 liter engines in Passat vehicles, and on 2.8 liter engines in Eurovan vehicles.

Special Tools

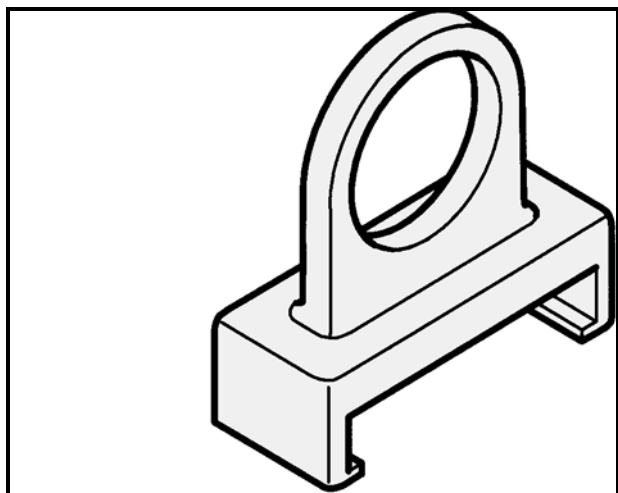

← **Puller T40039** - must be used to avoid damaging ignition coils during removal

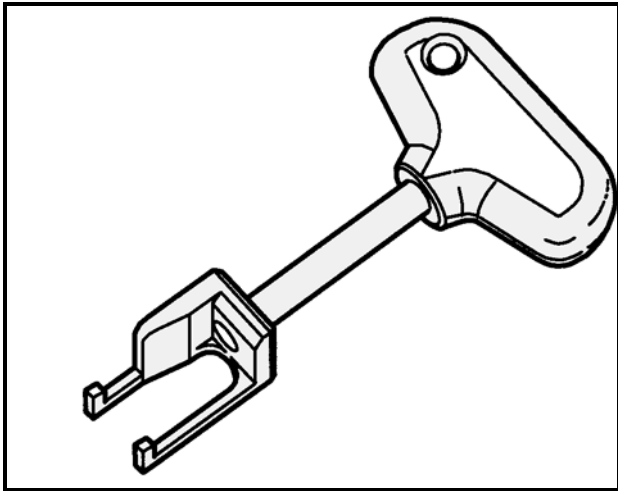

⇐ **Puller T10095** - must be used to avoid damaging ignition coils during removal

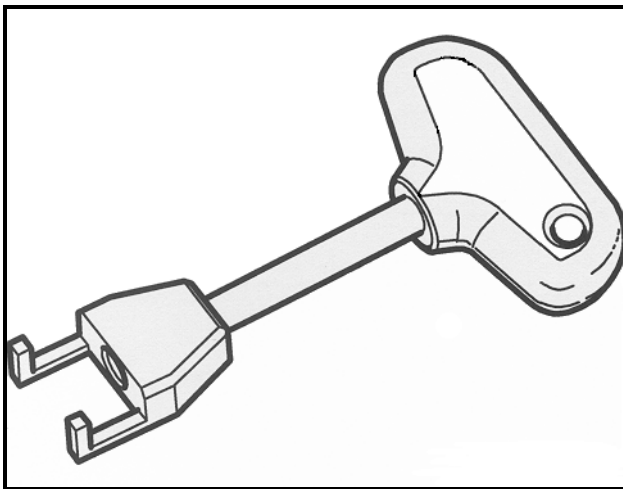

⇐ **Puller T10094** - must be used to avoid damaging ignition coils during removal

- **VAS 1978** - Wiring Harness Repair Kit

Parts: In addition to the ignition coils, other parts are needed on some vehicles. These parts are listed below:

For 2002 Jetta with automatic transmission and 2.8 liter engine:

<u>Quantity</u>	<u>Part Number</u>	<u>Part Name</u>
1	000 979 227	Repair Wire (from the VAS 1978 harness repair kit)
1	111 971 938 A	Butt Connector, (from the VAS 1978 harness repair kit)

For 2003 Jetta with automatic transmission and 2.8 liter engine:

<u>Quantity</u>	<u>Part Number</u>	<u>Part Name</u>
1	1J0 971 658 N	Harness Kit

Note: If assembled harness kit (1J0 971 658 N) is not available from parts, then the individual parts listed below can be assembled.

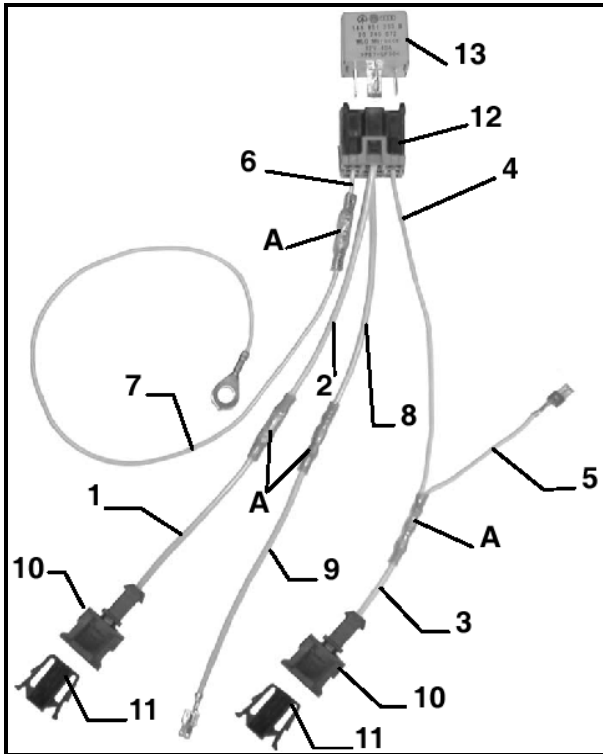

Item	Part Number	Qty.	Description
A	111 971 939 B	4	Butt Connector (Blue)*
1	000 979 220	1	Repair Wire*
2,8,9	000 979 227	2	Repair Wire*
3	000 979 130	1	Repair Wire*
4,6	000 979 114	1	Repair Wire*
5	000 979 135	1	Repair Wire*
7	000 979 137	1	Repair Wire*
10	191 972 761	2	Terminal Housing
11/11A	191 972 751	2	Terminal Housing
12	443 937 527	1	Relay Housing
13	141 951 253 B	1	Relay

* Parts available from the VAS 1978 harness repair kit

Relay, relay housing and terminal housings must be ordered through parts

Work Sequence:

Section A - 2.8 liter engine in Jetta and GTI vehicles

Section B - 1.8 liter engine in New Beetle, GTI, Jetta and Passat vehicles

Section C - 4.0 liter engine in Passat vehicles

Section D - 2.8 liter engine in Eurovan vehicles

Section A – 2.8 Liter Engine in Jetta and GTI

IMPORTANT! If the vehicle has a MIL light on, the diagnostic trouble codes (DTCs) must be checked. Only cylinder misfire DTCs related to ignition coil malfunction are covered by this service action. Any other checking, diagnosis or repairs are not part of or covered under this service action.

- If applicable, connect VAS5051 and check DTCs
- Open hood and remove engine cover

⇐ Disconnect connector from all ignition coils -1-

- Using **Puller T10095**, remove ignition coils

CAUTION: Use of tool T10095 is required to avoid damaging these sensitive components

NOTE: Only ignition coils that are **not** at the latest production level must be replaced. (Reference “Parts Information” on Page 3)

- Install new ignition coils (022 905 100 D/G) by pressing into cylinder head by hand only

IMPORTANT! Do not use any object to tap ignition coil into position. Do not twist ignition coil when installing.

- Reconnect connectors to ignition coils
- Reinstall engine cover
- If vehicle is a 2002 model year Jetta with automatic transmission go to Section A1
- If vehicle is a 2003 model year Jetta with automatic transmission go to Section A2

If vehicle is a Jetta or GTI with manual transmission go to Section A3

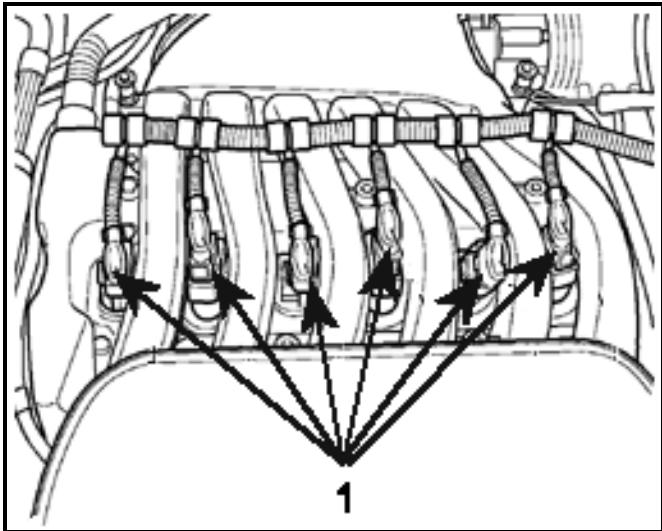

**Section A1 – Wiring Harness Modification on 2002
Model Year Jetta Vehicles having a
2.8 Liter Engine with an Automatic
Transmission**

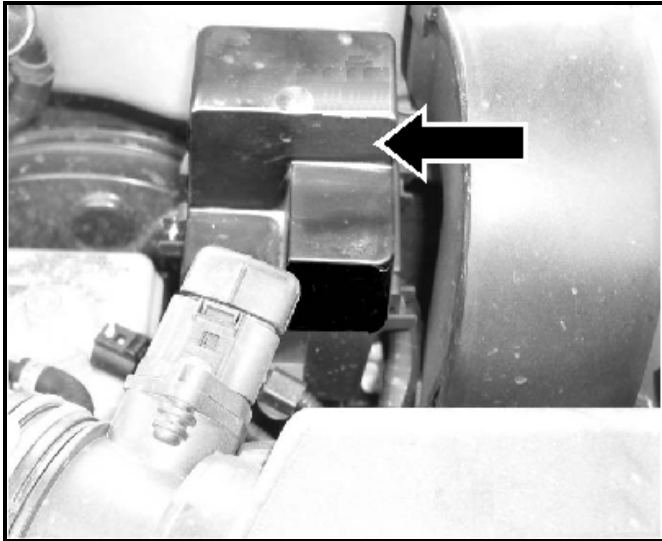

- Disconnect battery ground (GND) cable
- ⇐ Remove relay cover -arrow- for relay panel (located next to brake booster) in engine compartment

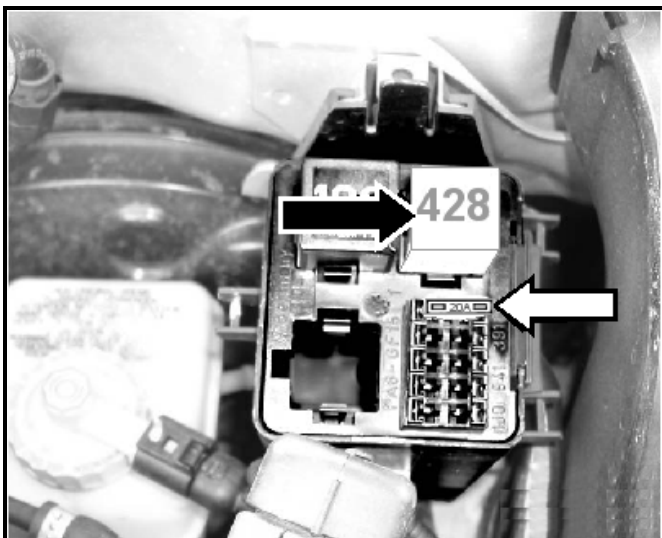

- ⇐ Remove fuse (S51) -white arrow- for vacuum pump from fuse holder
- ⇐ Remove relay #428 for the main power supply to the engine control module (ECM) -black arrow-
- Lift out relay panel from the lower housing

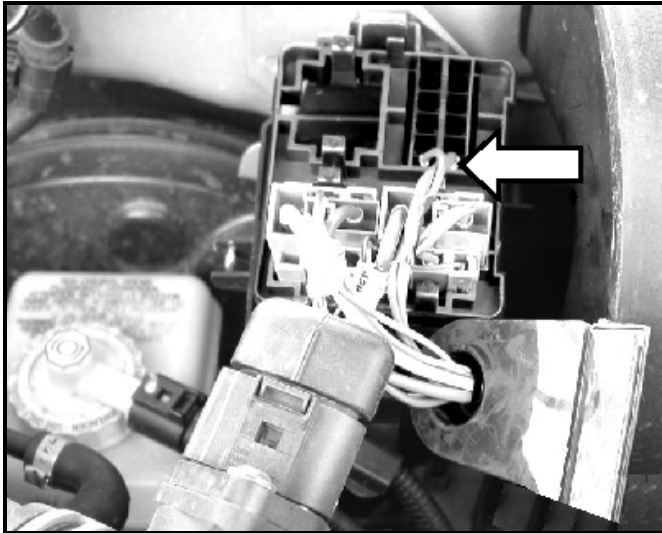

- Turn relay panel over to access wiring to fuse and relay

⇐ Remove large wire from cavity #1 for fuse (S51)
-arrow-

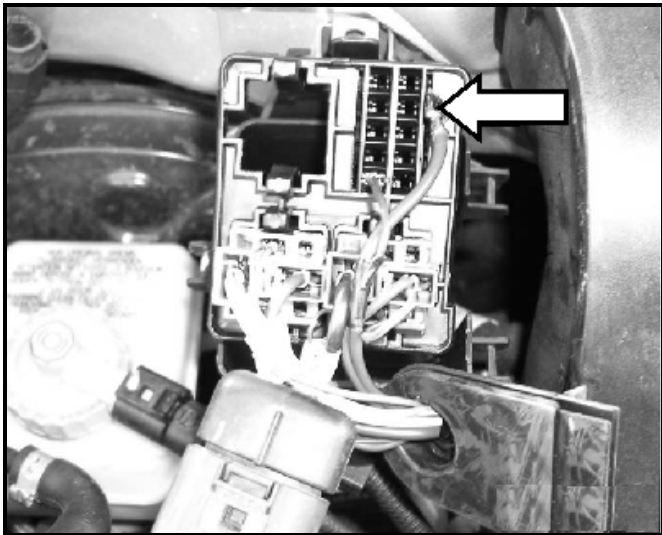

⇐ Illustration to the right shows large wire –arrow-
removed from cavity #1

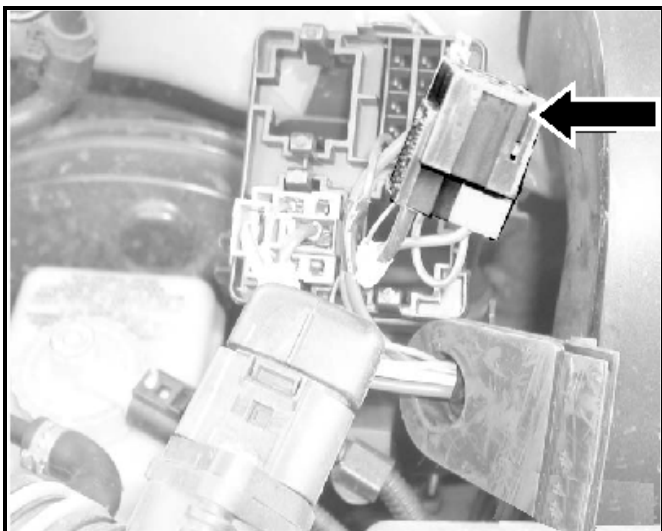

⇐ Remove red connector block (for relay #428)
-arrow- from the relay housing

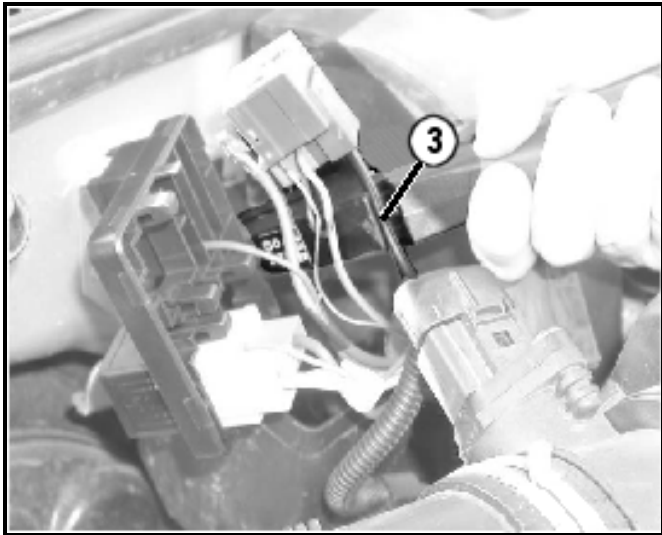

- ⇐ Locate large wire -3- from cavity 2 of the red connector for relay #428 and cut wire approximately 30 mm from terminal

Note: Cavity numbers are located on the connector at the terminal insertion points

- Strip insulation from wire ends using VAS 1978/3 wire strippers from the VAS 1978 repair kit

Note: The illustrations show the large wire installed in the relay connector housing. It may be easier to remove this terminal from the relay connector housing for the following modification

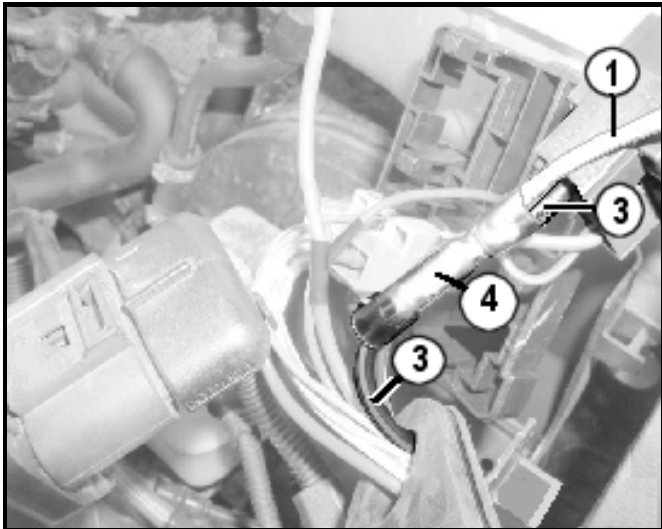

- Using new repair wire (000 979 227), cut wire approximately 100 mm from the terminal and strip the insulation from the wire (other end of the repair wire is not needed)

- ⇐ Insert the new 100 mm long repair wire -1- along with the end (30 mm length) of the previously cut wire -3- (from connector block cavity 2) into one end of a butt connector -4- (111 971 938 A)

- Crimp the butt connector using the VAS 1978/2 crimper from the VAS 1978 repair kit
- Insert remaining end of previously cut wire -3- into the other end of the butt connector -4- and crimp using the wire crimper
- Seal the butt connector using the electric hot air blower
- If the large wire was removed from the relay connector housing cavity #2 to do this modification, reinstall wire at this time

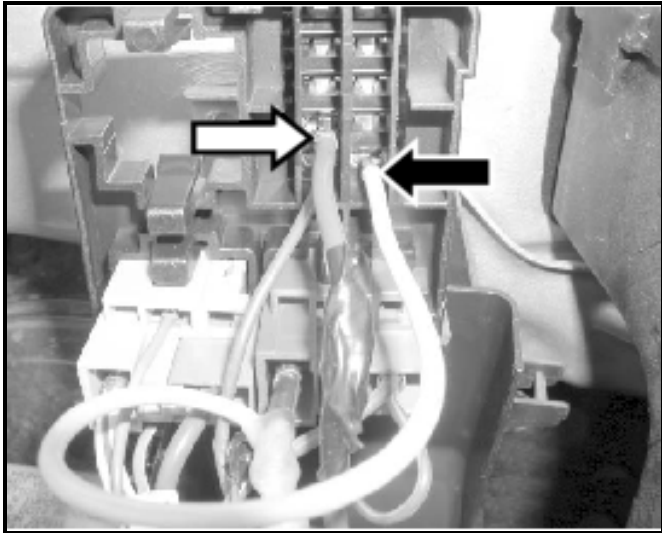

- Install the wire previously removed from the fuse holder (for fuse S51) cavity #1 into an unused cavity of the fuse holder (this wire is no longer used)

⇐ Note: In this illustration, cavity #4 was used - white arrow- however, your vehicle may be different

- ⇐ Install terminal from the 100 mm repair wire into the cavity #1 -black arrow- of the fuse holder
- Reinstall red connector block for relay into relay panel
- Reinstall relay panel into lower housing
- Reinstall relay #428 and fuse (S51) into relay panel
- Reinstall relay cover
- Reconnect battery ground (GND) cable and tighten nut to 6 Nm (53 in. lbs.)
- Go to Section A3

Section A2 – Wiring Harness Modification on 2003 Model Year Jetta Vehicles having a 2.8 liter engine with an Automatic Transmission

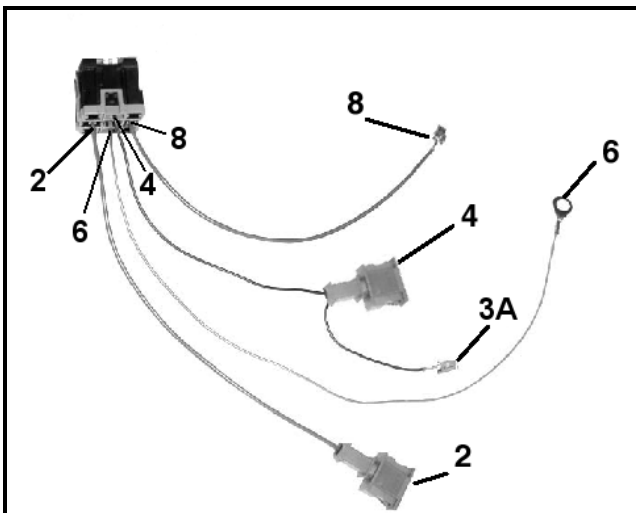

Note: Use harness kit (1J0 971 658 N). If not obtainable, the harness can be assembled. Some parts are in the VAS 1978 wiring harness repair kit other parts need to be ordered (Reference "Parts" on page 3.) Instructions for harness assembly are in Section A4

⇐ **Important! The terminal ends on the wire harness from the kit or from the assembled harness are shown to correspond to the terminal connection numbers on the relay connector**

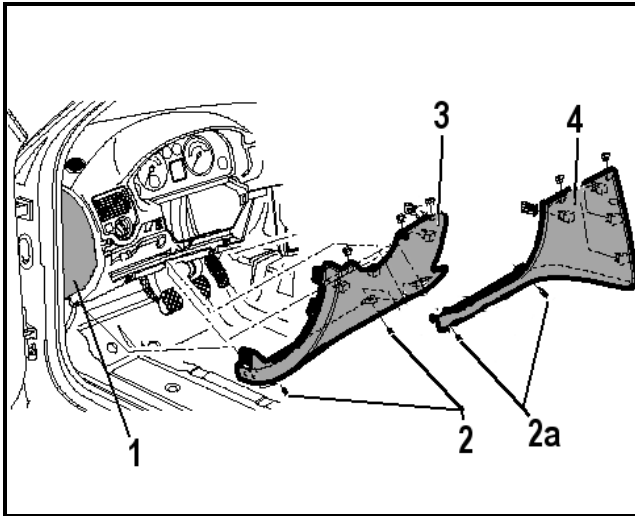

- ⇐ Open drivers door, remove instrument panel side cover -1-
- ⇐ Remove 2 screws -2- unclip trim panel -3- and remove
- ⇐ Remove 2 screws -2a- unclip trim panel -4 and remove

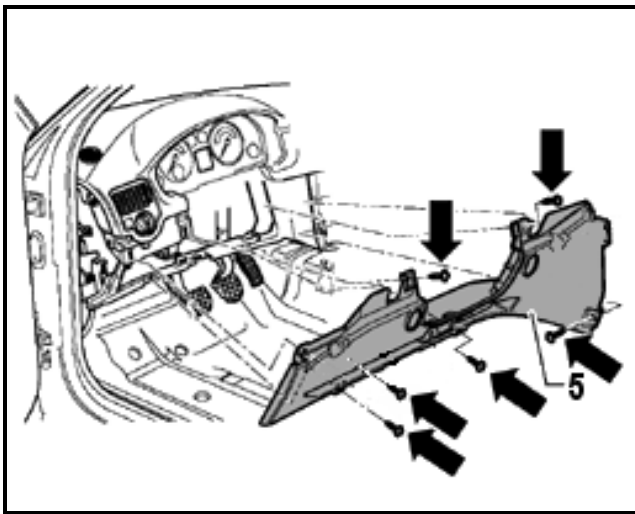

- ⇐ Remove (6) screws -arrows- and remove reinforcement -5-

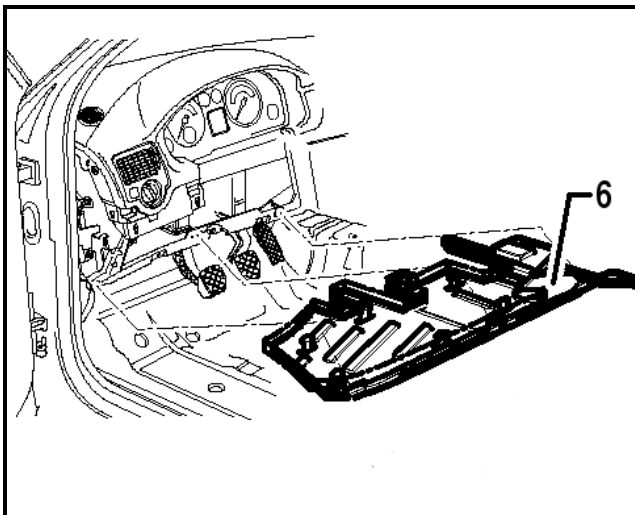

- ⇐ Unclip and remove lower cover -6- by sliding rearward out of clips

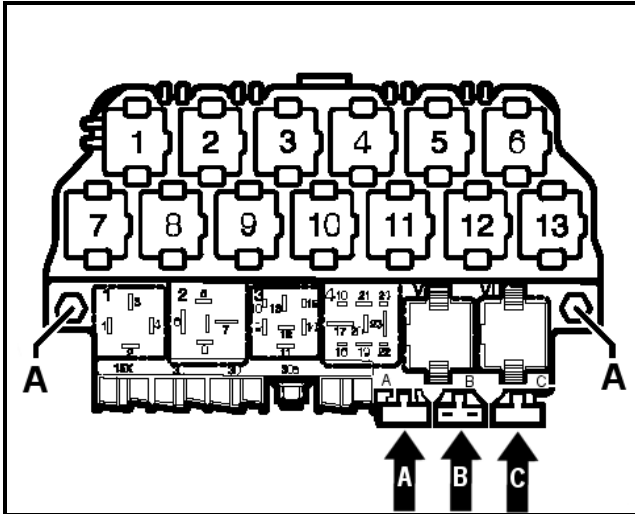

- ⇐ Using a volt meter, check the terminal contacts of the 15 amp fuse in position B -arrow- for (12 volts or B+ power) and make note of terminal position in fuse housing
- Under hood, remove battery cover and disconnect battery ground (GND) cable
- ⇐ Remove fuse/relay holders -A- and -C- (arrows) at the bottom of the lower relay panel
- ⇐ Remove fuse holder -B- from the bottom of lower relay panel -arrow- and remove fuse from holder
- ⇐ Remove (2) nuts -A- and pull lower relay carrier rearward and down to remove

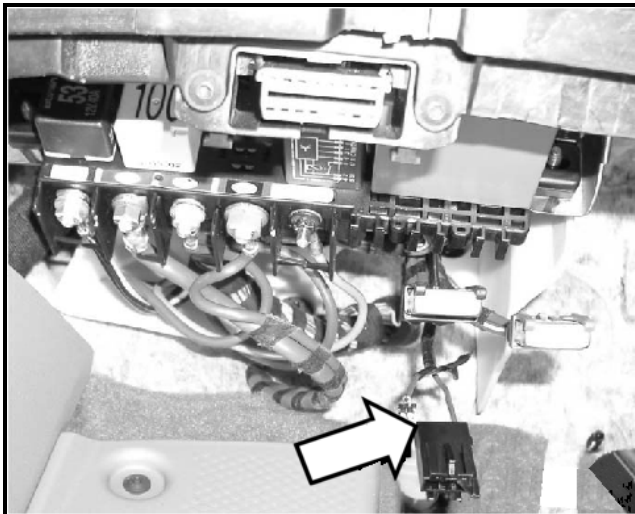

- ⇐ Remove the B+ terminal (as previously found) from fuse holder B -arrow-

Note: The illustration shows the wire removed from position #2, however, your vehicle could be different

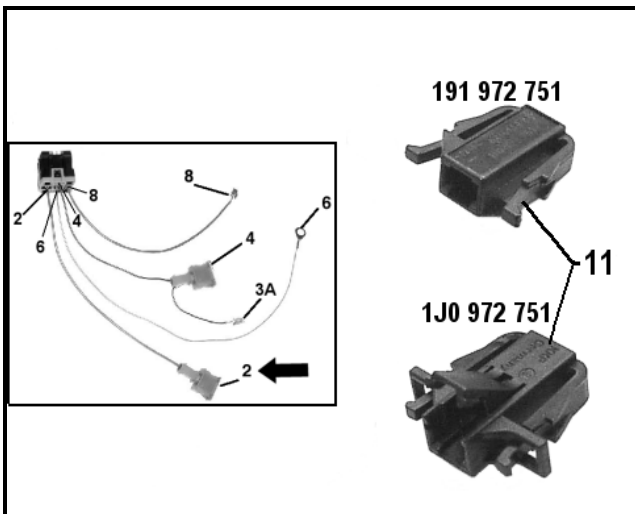

- ⇐ Insert the B+ terminal (removed from fuse holder) into terminal housing -11- (191 972 751 or 1J0 972 751)

Note: The terminal housing 1J0 972 751 comes with the wiring harness assembly.

Important! To insert the B+ terminal into the 1J0 972 751 housing, the side clip needs to be opened

Note: This terminal housing -11- will be connected to a terminal housing -2- on the new wiring harness later in the procedure

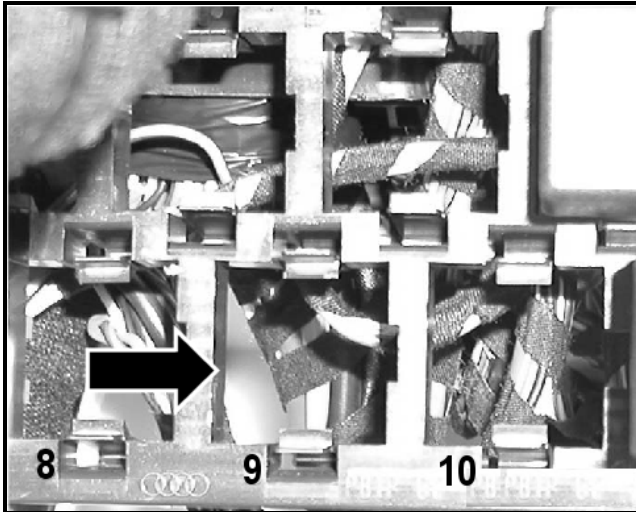

⇐ From the rear of the upper half of the relay panel, insert the new relay connector block on the new harness assembly into position #9 -arrow-

Note: The new relay must be removed from the relay connector on the new harness assembly before installing

- Route wires 2, 6 & 8 on the new harness assembly behind the fuse/relay panels

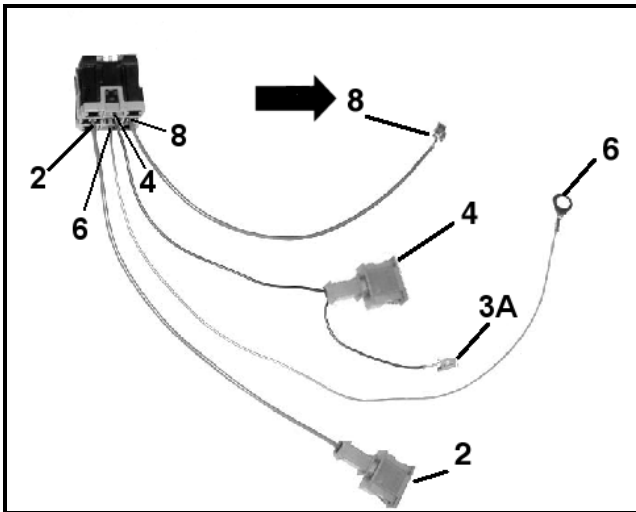

⇐ Locate terminal -8- (arrow) on the new wiring harness assembly

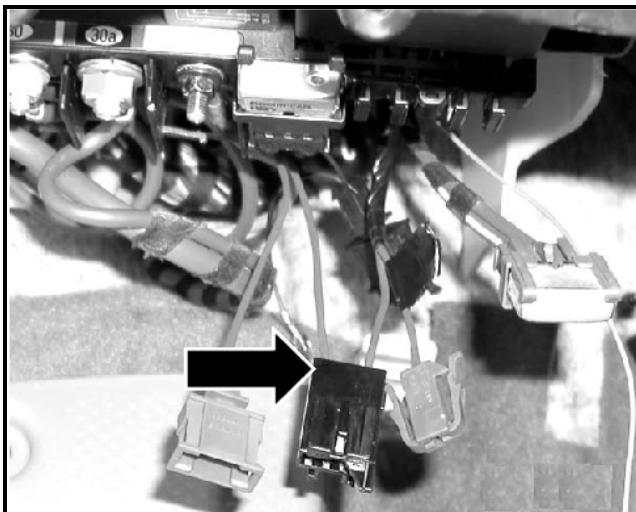

⇐ Insert terminal 8 on the new wire harness into the empty (B+) location in the 15 amp fuse holder -arrow-

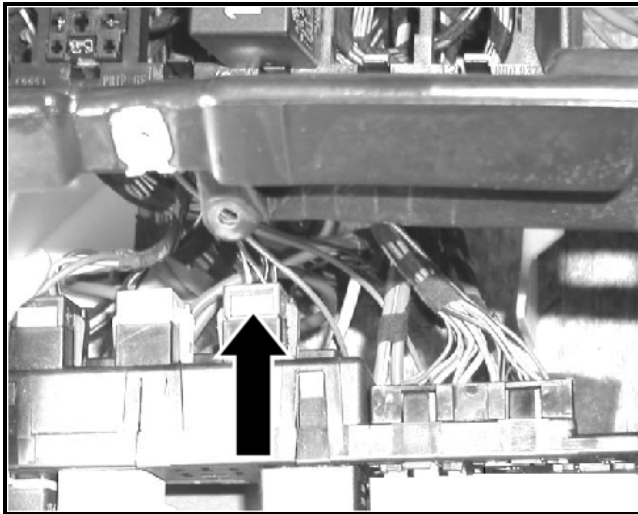

⇐ Remove (red) connector block -arrow- (for relay position 3) on reverse side of lower relay carrier

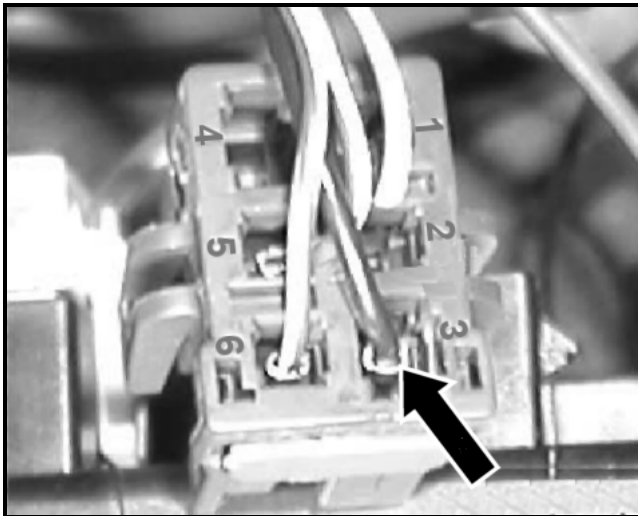

⇐ Remove terminal from position number 3 -arrow- of red connector block

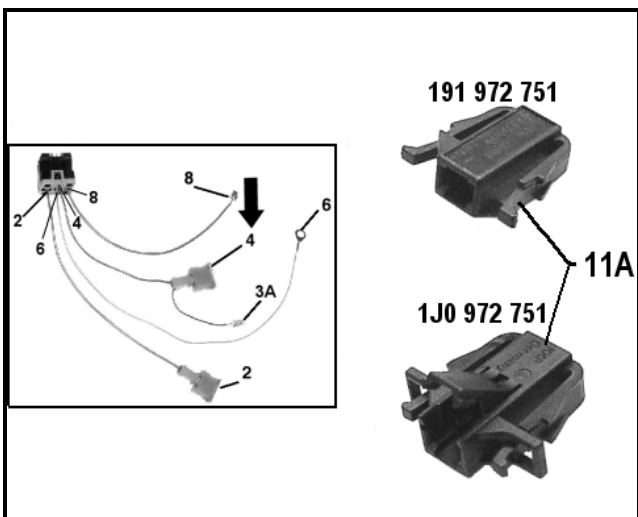

⇐ Insert this terminal -3- into connector housing -11A- (191 972 751 or 1J0 972 751)

Note: The terminal housing 1J0 972 751 comes with the wiring harness assembly.

Important! To insert terminal -3- into the 1J0 972 751 housing, the side clip needs to be opened

⇐ Connect the housing -11A- to the connector housing -4- on the new harness assembly

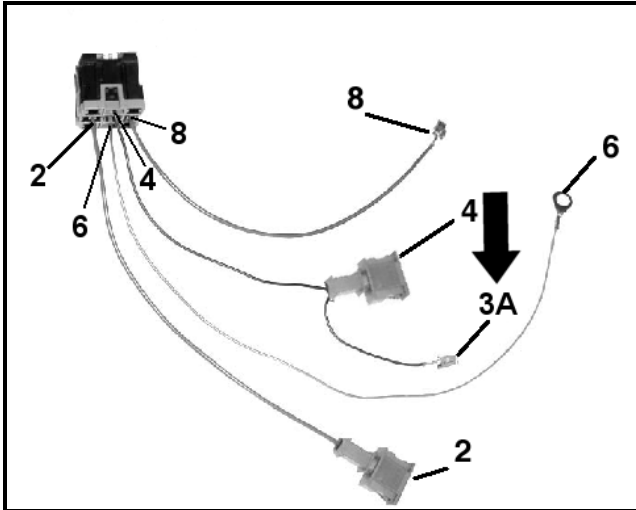

⇐ Locate terminal -3A- (arrow) (short wire from connector housing -4-) on new harness assembly

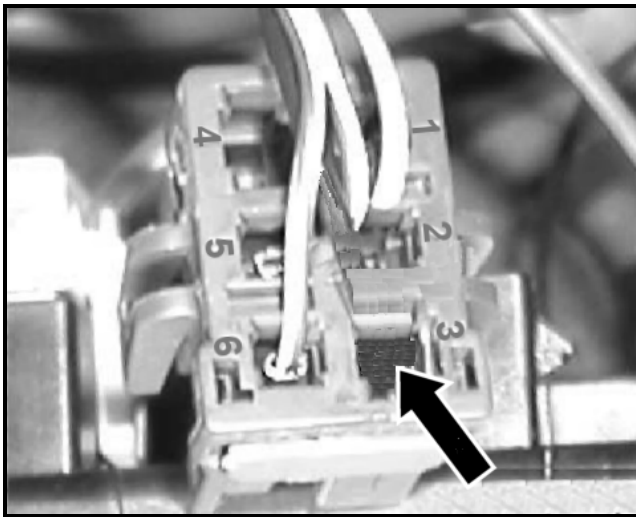

- ⇐ Insert terminal -3A- into the empty position number 3 -arrow- of red connector
- Reinstall red connector block to reverse side of relay panel (behind relay position 3)

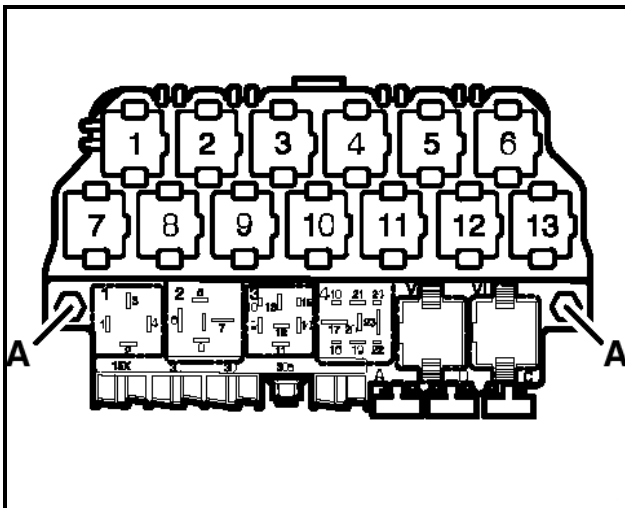

⇐ Reinstall relay carriers, secure with (2) nuts -A- and tighten to 2 Nm (18 in. lbs.)

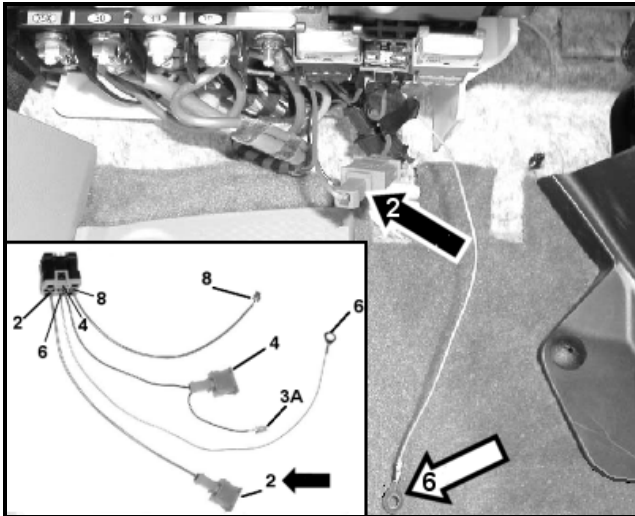

- ⇐ Insert the connector -11- (contains terminal removed from B+ fuse connector at the start of this procedure) to connector -2- (arrow) on the new wire harness assembly
- Reinstall fuse holder to location B on the lower relay block
- Reinstall 15 amp fuse
- Reinstall fuse/relay holders -A- & -C- into proper location on lower relay block
- ⇐ Locate ground (GND) wire -6- (eyelet terminal on the new wiring harness assembly)

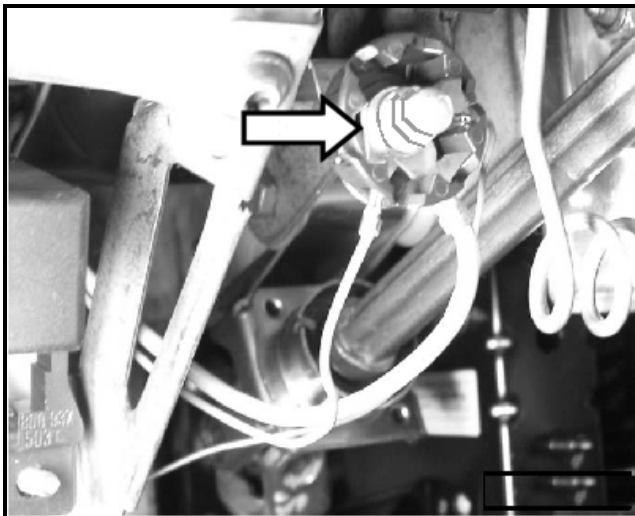

- ⇐ Remove cap nut at ground point -arrow- near steering column, install ground wire eyelet -6- from new harness assembly, secure with cap nut and tighten to 6 Nm (53 in. lbs.)

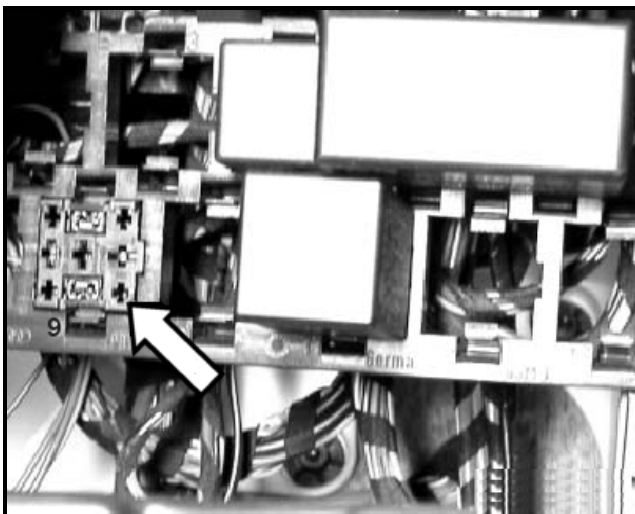

- ⇐ Install new (141 951 253 B) relay into upper relay block position 9 -arrow-
- Reinstall instrument panel lower cover
- Reinstall reinforcement and secure with (6) screws
- Reinstall lower trim panels
- Reinstall instrument panel side cover
- Reconnect battery ground (GND) cable and tighten to 6 Nm (53 in. Lbs)
- Reinstall battery cover
- Proceed to Section A3

Section A3 - Repair verification and readiness code setting

- If a wiring harness was modified, turn ignition switch “ON” and OFF” **before** first starting engine, then:
 - Start vehicle and verify correct operation
 - Remove key and wait up to 30 seconds to ensure that the vacuum pump does not run
 - Set engine readiness code and power restoration procedure
- If a wiring harness was not modified and the MIL light was on with cylinder misfire DTCs present, printed and erased, use VAS5051 and set engine readiness code
- Attach a copy of print out for diagnostic log (showing cylinder misfire DTCs) and readiness code “Test Complete” to repair order

Note: Readiness code setting is not related to this action when other components related to the MIL light are diagnosed and repaired

- ***Destroy and properly dispose of removed ignition coils***

Section A4 – Wiring Harness Assembly

Note: This section is needed only if the wiring harness assembly 1J0 971 658 N is not obtainable.

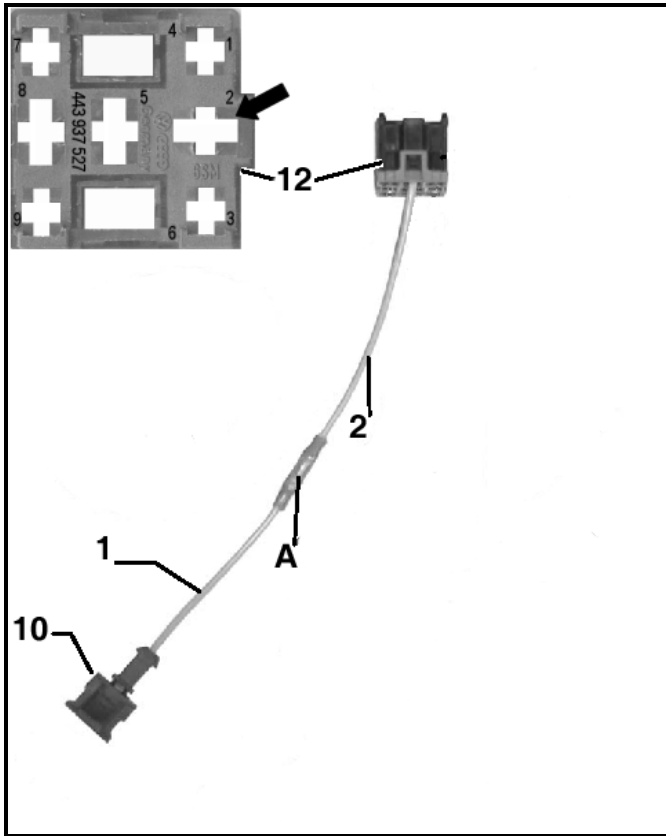

- ⇐ Using a repair wire -2- (000 927 227), cut wire approx. 100 mm from terminal, insert wire in butt connector -A- (111 971 939 B) and crimp butt connector with the VAS 1978/2 crimpmer
- ⇐ Using a repair wire -1- (000 979 220), cut wire approx. 100 mm from terminal, insert wire in butt connector -A- and crimp butt connector
- Seal the butt connector using the electric hot air blower from the VAS 1978 repair kit
- ⇐ Insert terminal end of wire -2- into position 2 -arrow- of relay connector -12- and wire end -1- into a terminal housing -10- (191 972 761)

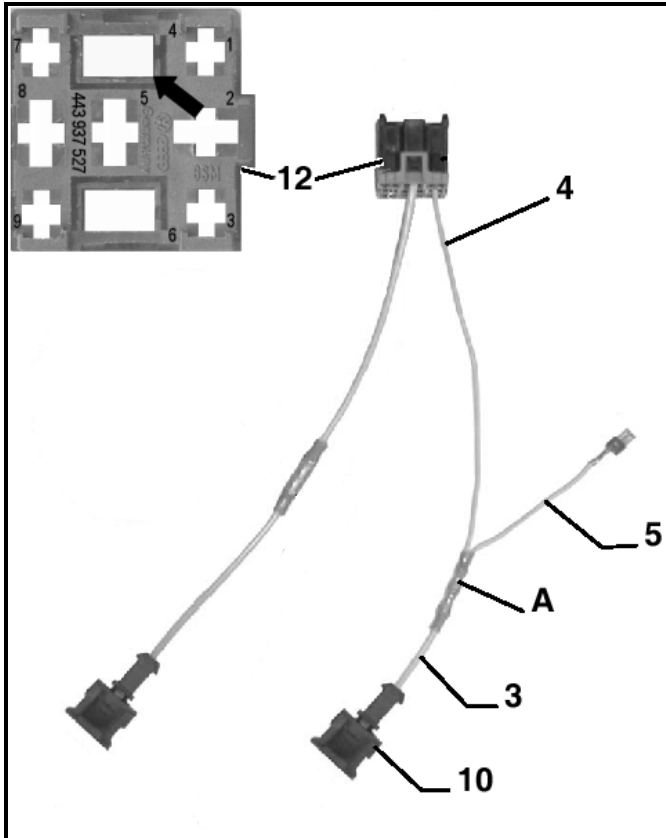

- ⇐ Using a repair wire -4- (000 979 114), cut wire approx. 150 mm from terminal
- ⇐ Using a repair wire -5- (000 979 135), cut wire approx. 80 mm from terminal
- ⇐ Insert ends of wire -4- & -5- into butt connector A- and crimp connector
- ⇐ Using a repair wire -3- (000 979 130), cut wire approx. 70 mm from terminal, insert wire in butt connector -A- and crimp butt connector
- Seal the butt connector using the electric hot air blower
- ⇐ Insert terminal end of wire -4- into position 4 arrow- of relay connector -12- and terminal end of wire -5- into terminal housing -10- (191 972 761)

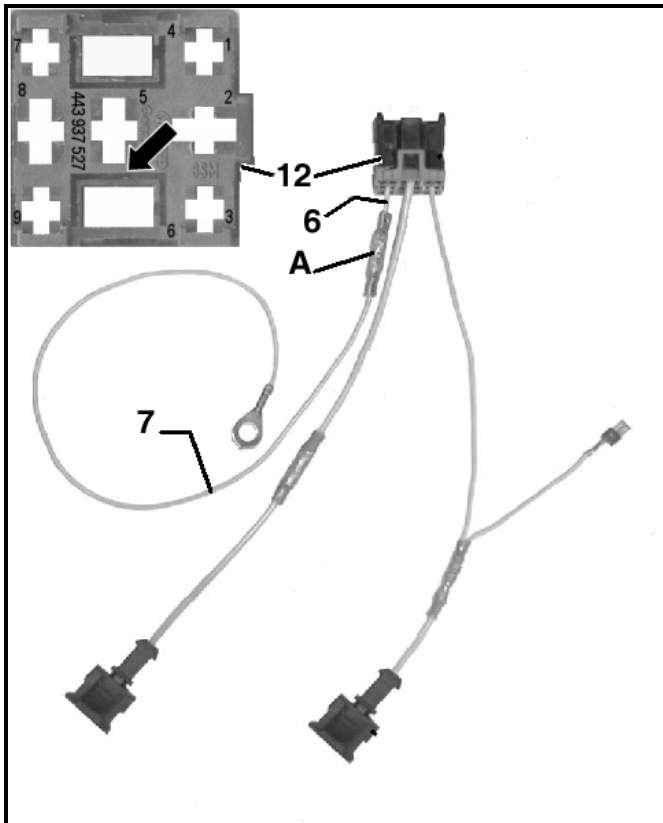

- ⇐ Using repair wire -6- (000 979 114), cut wire approx. 30 mm from terminal, insert into butt connector -A- and crimp connector
- ⇐ Using repair wire -7- (000 979 137), cut wire approx. 330 mm from eyelet, insert into butt connector -A- and crimp connector
- Seal the butt connector using the electric hot air blower
- ⇐ Insert terminal end of wire -6- into position 6 of relay connector -12-

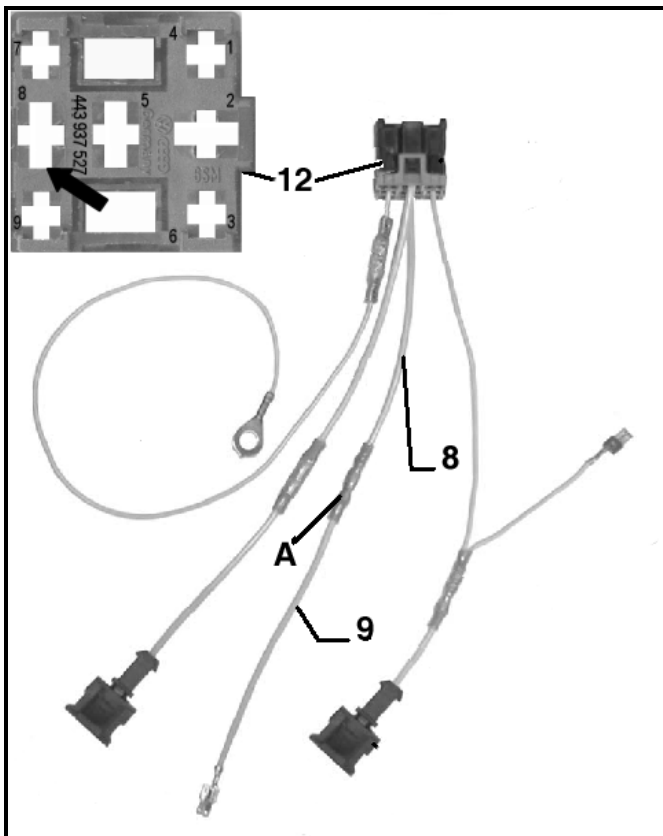

- ⇐ Using repair wire -8- (000 979 227), cut wire approx. 110 mm from eyelet, insert into butt connector -A- and crimp connector
- ⇐ Using repair wire -9- (000 979 227), cut wire approx. 110 mm from eyelet, insert into butt connector -A- and crimp connector
- Seal both ends of the butt connector using the electric hot air blower
- ⇐ Insert terminal end of wire -8- into position 8 of relay connector -12-
- Go to Section A2 for harness installation

Section B – 1.8 Liter Engine in New Beetle, GTI, Jetta and Passat

IMPORTANT! If the vehicle has a MIL light on, the diagnostic trouble codes (DTCs) must be checked. Only cylinder misfire DTCs related to ignition coil malfunction are covered by this service action. Any other checking, diagnosis or repairs are not part of or covered under this service action.

- If applicable, connect VAS5051 and check DTCs
- Open hood and remove engine cover
- If applicable, remove screw securing vacuum reservoir located above ignition coils
- On New Beetle vehicles, remove plate with turbo boost valve and move aside

Note: Vacuum lines to reservoir and turbo boost valve do not have to be disconnected

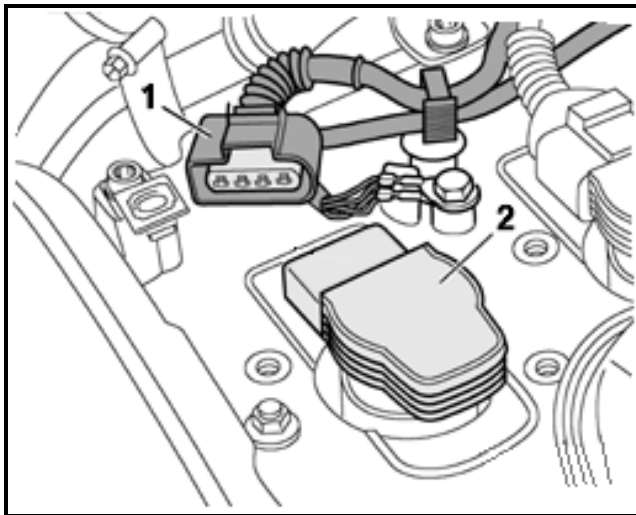

⇐ Disconnect connectors -1- from all ignition coils -2-

NOTE: Only ignition coils that are **not** at the latest production level must be replaced. (Reference “Parts Information” on Page 3)

- Using **Puller T40039**, remove ignition coils

CAUTION: Use of tool T40039 is required to avoid damaging these sensitive components

- Install new ignition coils (06B 905 115J/L) by pressing into cylinder head with hand only

IMPORTANT! Do not use any object to tap ignition coil into position. Do not twist ignition coil when installing.

- Reconnect connectors to ignition coils
- If applicable, reinstall plate with turbo boost valve

- Reinstall vacuum reservoir and secure with bolt
- Reinstall engine cover and close hood
- If the MIL light was on and cylinder misfire DTCs were present, printed and erased, use VAS5051 and set engine readiness code
- Attach a copy of print out for diagnostic log (showing cylinder misfire DTCs) and readiness code "Test Complete" to repair order

Note: Readiness code setting is not related to this action when other components related to the MIL light are diagnosed and repaired

- ***Destroy and properly dispose of removed ignition coils***

Section C – 4.0 Liter Engine in Passat

IMPORTANT! If the vehicle has a MIL light on, the diagnostic trouble codes (DTCs) must be checked. Only cylinder misfire DTCs related to ignition coil malfunction are covered by this service action. Any other checking, diagnosis or repairs are not part of or covered under this service action.

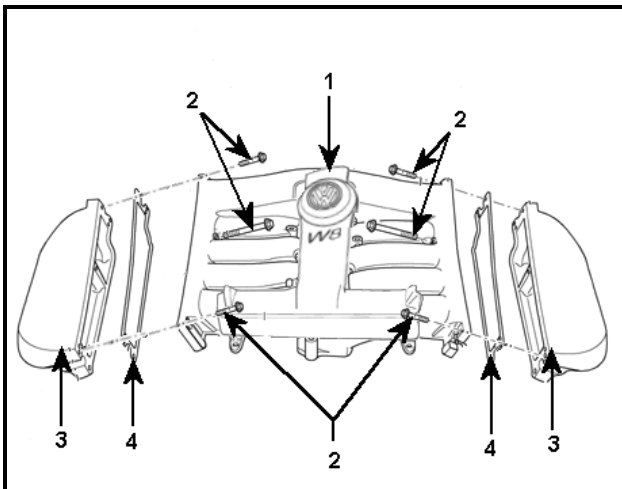

- If applicable, connect VAS5051 and check DTCs
- ⇐ Open hood and remove center manifold cover -1-
- ⇐ Remove bolts -2- securing left and right intake manifold side parts -3- and remove side part with gaskets -4-
- Disconnect connectors on all ignition coils

NOTE: Only ignition coils that are **not** at the latest production level must be replaced. (Reference "Parts Information" on Page 3)

- Using **Puller T10094**, remove ignition coils on left and right banks of engine

CAUTION: Use of tool T10094 is required to avoid damaging these sensitive components

- Install new ignition coils (07C 905 115C/D) by pressing into cylinder head by hand only

IMPORTANT! Do not use any object to tap ignition coil into position. Do not twist ignition coil when installing.

- Reconnect connectors to ignition coils
- Reinstall left and right intake manifold side parts with gasket and tighten bolts to 8 Nm. (71 in. lbs.)
- Reinstall center cover and close hood
- If the MIL light was on and cylinder misfire DTCs were present, printed and erased, use VAS5051 and set engine readiness code
- Attach a copy of print out for diagnostic log (showing cylinder misfire DTCs) and readiness code "Test Complete" to repair order

Note: Readiness code setting is not related to this action when other components related to the MIL light are diagnosed and repaired

- ***Destroy and properly dispose of removed ignition coils***

Section D – 2.8 Liter Engine in Eurovan

IMPORTANT! If the vehicle has a MIL light on, the diagnostic trouble codes (DTCs) must be checked. Only cylinder misfire DTCs related to ignition coil malfunction are covered by this service action. Any other checking, diagnosis or repairs are not part of or covered under this service action.

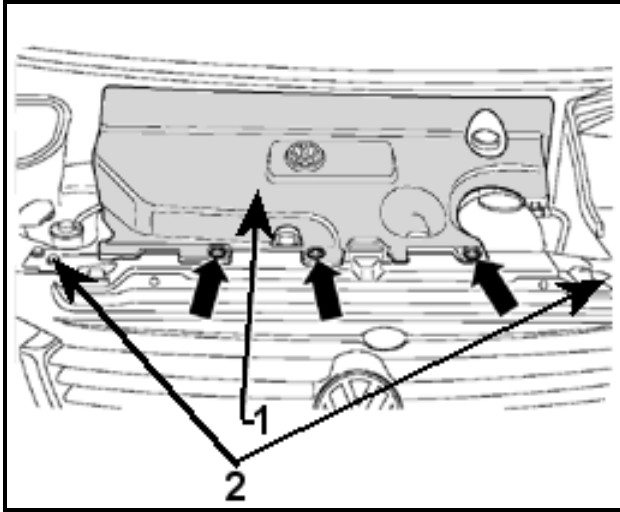

- If applicable, connect VAS5051 and check DTCs

⇐ Open hood and remove three T30 torx® screws -arrows- securing engine cover -1- and remove engine cover

⇐ Remove bolts -2- on left and right side of vehicle and pivot radiator forward to service position. Refer to Technical Bulletin v190402 for the correct method of putting the radiator in service position.

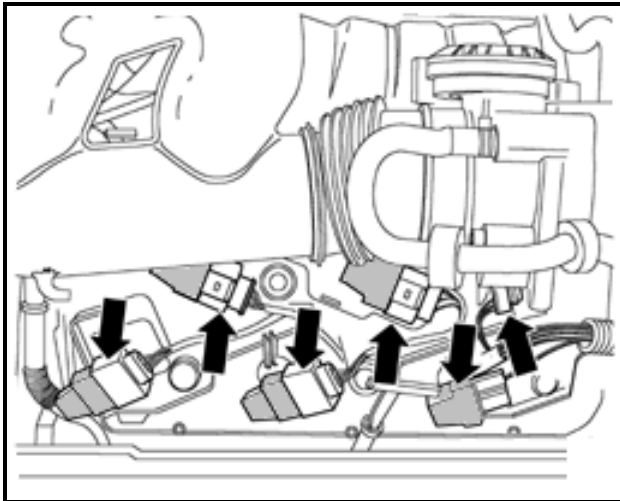

⇐ Disconnect connectors -arrows- from all ignition coils

NOTE: Only ignition coils that are **not** at the latest production level must be replaced. (Reference "Parts Information" on Page 3)

⇐ Using **Puller T10095**, remove ignition coils

CAUTION: Use of tool T10095 is required to avoid damaging these sensitive components

- Install new ignition coils (022 905 100C/F) by pressing into cylinder head by hand only

IMPORTANT! Do not use any object to tap ignition coil into position. Do not twist ignition coil when installing.

- Reconnect connectors to ignition coils
- Move radiator rearward and secure in position with bolts and tighten to 10 Nm (88 in. lbs.)

- Reinstall engine cover and secure with T30 Torx® screws
- If the MIL light was on and cylinder misfire DTCs were present, printed and erased, use VAS5051 and set engine readiness code
- Attach a copy of print out for diagnostic log (showing cylinder misfire DTCs) and readiness code “Test Complete” to repair order

Note: Readiness code setting is not related to this action when other components related to the MIL light are diagnosed and repaired

Destroy and properly dispose of removed ignition coils

Time Requirements/Reimbursement

To ensure prompt reimbursement, be sure to enter, immediately replacement of the ignition coils the applicable reimbursement code listed below.

WG Data Entry Procedure

Claim Type	Repair Code (Damage Code Field)	Time Units	Work Scope
RC	WG12	50 T.U.	<u>2.8L Jetta & GTI Vehicles</u> - Replace ignition coils 6 022 905 100D/G Ignition coil
RC	WG13	110 T.U.	<u>2.8L Jetta & GTI Vehicles</u> - Replace ignition coils - Fault Diagnosis and Set Readiness Code 6 022 905 100D/G Ignition coil
RC	WG14	40 T.U.	<u>1.8T New Beetle, Jetta, GTI & Passat Vehicles</u> - Replace ignition coils 4 06B 905 115J/L Ignition coil
RC	WG15	100 T.U.	<u>1.8T New Beetle, Jetta, GTI & Passat Vehicles</u> - Replace ignition coils - Fault Diagnosis and Set Readiness Code 4 06B 905 115J/L Ignition coil
RC	WG16	110 T.U.	<u>4.0L Passat W8 Vehicles</u> - Replace ignition coils 8 07C 905 115C/D Ignition coil
RC	WG17	170 T.U.	<u>4.0L Passat W8 Vehicles</u> - Replace ignition coils - Fault Diagnosis and Set Readiness Code 8 07C 905 115C/D Ignition coil
RC	WG18	50 T.U.	<u>2.8L EuroVan V6 Vehicles</u> - Replace ignition coils 6 022 905 100C/F Ignition coil
RC	WG19	110 T.U.	<u>2.8L EuroVan V6 Vehicles</u> - Replace ignition coils - Fault Diagnosis and Set Readiness Code 6 022 905 100C/F Ignition coil

The system automatically enters the part number and labor applicable to the above listed codes.

SUBLETS At-A-Glance

	<u>SUB LBR</u>	<u>SUB PTS</u>
P/N 000 979 227 Wire (from the VAS 1978 harness repair kit)		\$ 2.31, if applicable
P/N 111 971 938 A Butt Connector (from the VAS 1978 harness repair kit)		\$ 3.19, if applicable
110 TU for labor on 2002 Jetta automatic wiring harness modification	Add 110 TU at dealer's established labor rate, if applicable	
130 TU for labor on 2003 Jetta automatic to install new wiring harness assembly	Add 130 TU at dealer's established labor rate, if applicable	
165 TU for labor on 2003 Jetta automatic to assemble and install new wiring harness assembly	Add 165 TU at dealer's established labor rate, if applicable	

TO BE PROPERLY REIMBURSED, IT IS IMPERATIVE THAT A SUBLET AMOUNT IS CLAIMED IN THE PROPER SUBLET FIELD AS IDENTIFIED and THAT SUBLET EXPENSE COPIES REMAIN ATTACHED TO YOUR COPY OF THE REPAIR ORDER.

Please note that in some instances vehicles repaired prior to this action already have improved coils (reference "Parts Information" on page 3) and do not require replacement.

The above reimbursement codes assume all coils were replaced on respective vehicles.
Adjustments will be made on claims where improved coil replacement occurred prior to initiation of the WG Service Action.

For vehicles that, according to your information, cannot be corrected, and one of the codes below best describe the reason, please enter into the system one of the codes indicated, as applicable:

WG 20	Customer Refused Repairs
WG 30	Total Loss
WG 40	Vehicle Stolen
WG 50	Vehicle Exported

California Emission Recall Requirements – For California Dealers ONLY

The California Air Resources Board and the Department of Motor Vehicles (DMV) require that emissions-related recalls be completed prior to vehicle registration renewal. **It is, therefore, imperative that upon completion of this recall work that you provide the owner with a signed "Vehicle Emission Recall – Proof of Correction" Certificate.** This certificate, #RC0801 CALEM ALL, will accompany the California owner notification letters. The California Department of Motor Vehicles requires that the size and color of the certificate is identical to the sample provided in this package. Therefore, *if you need additional certificates please order them through Dyment using the above-mentioned order number.*

Service Action Verification

For verification, **always** check the OTIS View Campaign inquiry screen. The OTIS system is the **only** binding campaign inquiry and verification system; other systems *are not valid and may result in non-payment of a claim.*

Service Help

If you have questions regarding this or any other recall or service action, please call **(800) 741-2919**.

Dealer Personnel Information

Please inform and/or provide a copy of this important communication to every person in your dealership who has campaign-related responsibilities, including parts and accounting personnel.

Thank you for your cooperation.

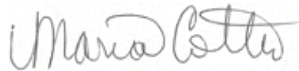

Maria Cotter
Product Compliance



California Regulations

Dear Mr. Sample,

We are now accelerating the process of replacing all ignition coils in cars potentially affected, whether a malfunction has occurred or not. We are writing to you today to invite you to return to your Volkswagen dealer to have your vehicle updated.

If an ignition coil becomes inoperative, the engine and its electronic controls are designed to keep your vehicle running. Your Malfunction Indicator Lamp (MIL) will illuminate and you may experience some deterioration in performance. This condition may also affect the emissions of your vehicle. You can continue driving and should take your car to the nearest Volkswagen dealer for repair.

The update to your vehicle will take less than one hour. Please call the service department of your Volkswagen dealer to schedule an appointment.

*California regulations require that this repair be completed prior to the time that you renew your vehicle registration. **Please make sure that this repair is completed prior to the renewal of your vehicle registration** and that you furnish proof of repair to the DMV in the form of a copy of the dealer's repair order including a signed "Emission Campaign Performance Authorization" which is enclosed with this letter. Please retain the signed certification form with your vehicle records. DO NOT MAIL THIS FORM to the Department of Motor Vehicles (DMV) unless requested.*

If you are the lessor and registered owner of the vehicle identified in this action, please forward this information immediately by first class mail to the lessee.

If you have already incurred out-of-pocket expenses, please write us at the address below, and we'll be happy to reimburse you. Please include any receipts you might have along with your letter.

Volkswagen of America, Inc.
Attn: Customer Relations
3499 Hamlin Road
Rochester Hills, MI 48309

I want to emphasize that taking care of you, our customer, remains our highest priority and we thank you for your patience. If you have any further questions, or require assistance locating a Volkswagen dealer, please visit vw.com or call us directly at (800) 822-8987.

Thank you for your continued loyalty.

Sincerely,

Frank Maguire
Vice President



49 States

Dear Mr. Sample,

We are now accelerating the process of replacing all ignition coils in cars potentially affected, whether a malfunction has occurred or not. We are writing to you today to invite you to return to your Volkswagen dealer to have your vehicle updated.

If an ignition coil becomes inoperative, the engine and its electronic controls are designed to keep your vehicle running. Your Malfunction Indicator Lamp (MIL) will illuminate and you may experience some deterioration in performance. This condition may also affect the emissions of your vehicle. You can continue driving and should take your car to the nearest Volkswagen dealer for repair.

The update to your vehicle will take less than one hour. Please call the service department of your Volkswagen dealer to schedule an appointment.

If you are the lessor **and registered owner of the vehicle identified in this action, please forward this information immediately by first class mail to the lessee.**

If you have already incurred out-of-pocket expenses, please write us at the address below, and we'll be happy to reimburse you. Please include any receipts you might have along with your letter.

Volkswagen of America, Inc.
Attn: Customer Relations
3499 Hamlin Road
Rochester Hills, MI 48309

I want to emphasize that taking care of you, our customer, remains our highest priority and we thank you for your patience. If you have any further questions, or require assistance locating a Volkswagen dealer, please visit vw.com or call us directly at (800) 822-8987.

Thank you for your continued loyalty.

Sincerely,

Frank Maguire
Vice President

Volkswagen of America, Inc.



3800 Hamlin Road
Auburn Hills, MI 48326

December 2003

Dear Volkswagen Dealer:

This letter is to inform you that the WG Service Action circular has been updated to include additional information on repairing 2002 model year Jetta vehicles with automatic transmissions. We will begin notifying these owners on or about December 29, 2003.

Please refer to the revised Service Action Circular WG (enclosed) for additional information, including a copy of the customer letter. Please share this information with all personnel with campaign-related responsibilities.

Thank you for your cooperation and assistance in this important matter.

Sincerely,

A handwritten signature in cursive script that reads "Maria Cotter".

Maria Cotter
Product Compliance

**IMPORTANT! Please provide a copy to all personnel with campaign-related responsibilities!
This supercedes the WG Service Action dated May 2003**



Service Action Circular

Code: **WG**

December 2003

Subject: 2001–2003 Model Year Volkswagen Vehicles Replace Ignition Coils

This is to inform you of the initiation of a service action campaign involving some below identified 2001 through 2003 model year Volkswagen vehicles. This service action pertains to the replacement of the ignition coils.

Problem Description

It is possible that if one of the vehicle's ignition coils fails, rough idling or reduced driving power could occur in addition to illumination of the MIL light.

Remedial Action

Replace ignition coils in each affected vehicle.

Vehicle Identification and VIN Number Ranges

The vehicles affected by this action are identified as follows:

2001 – 2003 New Beetle 1.8T

3VW_ *_ _1C_1M000001 - 3VW_ *_ _1C_3M414843

(* Vehicles with C in 5th position for model year 2001 only) (* Vehicles with D in 5th position for model years 2001-03) (* Vehicles with E in 5th position for model year 2003 only)

2002 – 2003 Golf (GTI) 1.8T, Jetta 1.8T

9BW_ *_ _1J_2_000001 - 9BW_ *_ _1J_34032850

(*Vehicles with D or E in 5th position for model year 2002 only) (*Vehicles with E in 5th position for model year 2003)

3VW_ *_ _9M_2M000001 - 3VW_ *_ _9M_3M051297

(*Vehicles with D or E in 5th position for model year 2002 only) (*Vehicles with E in 5th position for model year 2003)

WVW_ *_ _1J_2W000001 - WVW_ *_ _1J_3W334992

(*Vehicles with D or E in 5th position for model year 2002 only) (*Vehicles with E in 5th position for model year 2003)

2002 – 2003 GTI V6

9BW_H_1J_24000001 - 9BW_H_1J_34040002

2002 – 2003 Jetta GLI

3VW_H_9M_2M000001 - 3VW_H_9M_3M105131

WVW_H_1J_2W000001 - WVW_H_1J_3W367577

2001 – 2003 Passat 1.8T

WVW_ *_ _3B_1E000001 - WVW_ *_ _3B_3E175002

WVW_ *_ _3B_1P000001 - WVW_ *_ _3B_3P265086

(*Vehicles with C or D in 5th position for model year 2001 only) (*Vehicles with D in 5th position for model years 2002/3)

2002 – 2003 Passat W8

WVW_K_3B_2P000001 - WVW_K_3B_3P263779

WVW_K_3B_2E000001 - WVW_K_3B_3E177001

2001 – 2003 EuroVan V6

WV_ _B_70_1H000519 - WV_ _B_70_3H091264

Owner Notification Mailing

Volkswagen began the initial mailings to inform all known owners of this service action campaign by first class mail on or about June 6, 2003.

Vehicle Allocation

Each dealer will receive a computer printout listing containing VINs and owner information of owners which have been notified.

Parts Information

You will receive automatic parts allocations based on owner notification mailings to owners located within your area of responsibility. Do not place an order on your own until further notice.

<i>New Beetle 1.8T</i>	-	<i>06B 905 115J/L</i>
<i>Golf(GTI), Jetta 1.8T</i>	-	<i>06B 905 115J/L</i>
<i>GTI, Jetta GLI</i>	-	<i>022 905 100D/G</i>
<i>Passat 1.8T</i>	-	<i>06B 905 115J/L</i>
<i>Passat W8</i>	-	<i>07C 905 115C/D</i>
<i>EuroVan V6</i>	-	<i>022 905 100C/F</i>

Work Procedure

Objective: This procedure describes changing the ignition coils on 1.8 liter & 2.8 liter engines in New Beetle, GTI & Jetta vehicles, a wire harness modification for 2002 Jetta vehicles having a 2.8 liter engine with an automatic transmission, changing the ignition coils on 1.8 liter & 4.0 liter engines in Passat vehicles, and on 2.8 liter engines in Eurovan vehicles.

Special Tools

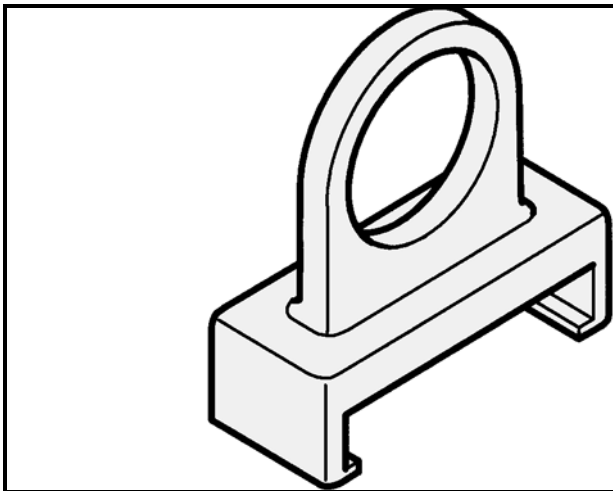

⇐ **Puller T40039** - must be used to avoid damaging ignition coils during removal

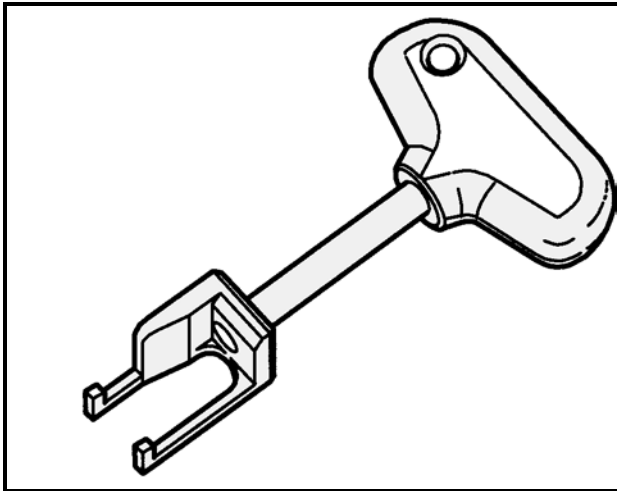

⇐ **Puller T0095** - must be used to avoid damaging ignition coils during removal

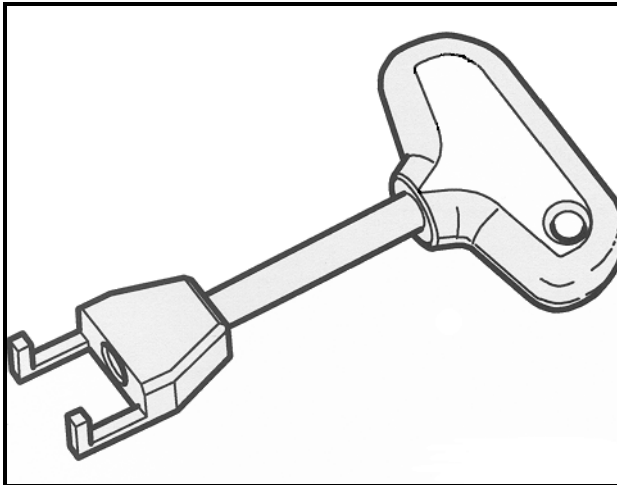

⇐ **Puller T10094** - must be used to avoid damaging ignition coils during removal

- **VAS 1978** - Wiring Harness Repair Kit

Parts: Additional Parts needed with ignition coil replacement for 2002 Jetta having a 2.8 Liter engine with an automatic transmission

<u>Quantity</u>	<u>Part Number</u>	<u>Part Name</u>
1	000 979 227	Wire (from the VAS 1978 harness repair kit)
1	111 971 938 A	Butt Connector (from the VAS 1978 harness repair kit)

Work Sequence:

Section A - 2.8 liter engine in Jetta and GTI vehicles

Section B - 1.8 liter engine in New Beetle, GTI, Jetta and Passat vehicles

Section C - 4.0 liter engine in Passat vehicles

Section D - 2.8 liter engine in Eurovan vehicles

Section A – 2.8 Liter Engine in Jetta and GTI

IMPORTANT! If the vehicle has a MIL light on, the diagnostic trouble codes (DTCs) must be checked. Only cylinder misfire DTCs related to ignition coil malfunction are covered by this service action. Any other checking, diagnosis or repairs are not part of or covered under this service action.

- If applicable, connect VAS5051 and check DTCs
- Open hood and remove engine cover

⇐ Disconnect connector from all ignition coils -1-

- Using **Puller T10095**, remove ignition coils

CAUTION: Use of tool T10095 is required to avoid damaging these sensitive components

NOTE: Only ignition coils that are **not** at the latest production level must be replaced. (Reference “Parts Information” on Page 3)

- Install new ignition coils (022 905 100 D/G) by pressing into cylinder head by hand only

IMPORTANT! Do not use any object to tap ignition coil into position. Do not twist ignition coil when installing.

- Reconnect connectors to ignition coils
- Reinstall engine cover
- If vehicle is a 2002 model year Jetta with automatic transmission go to Section A1
- If vehicle is a Jetta or GTI with manual transmission go to Section A2

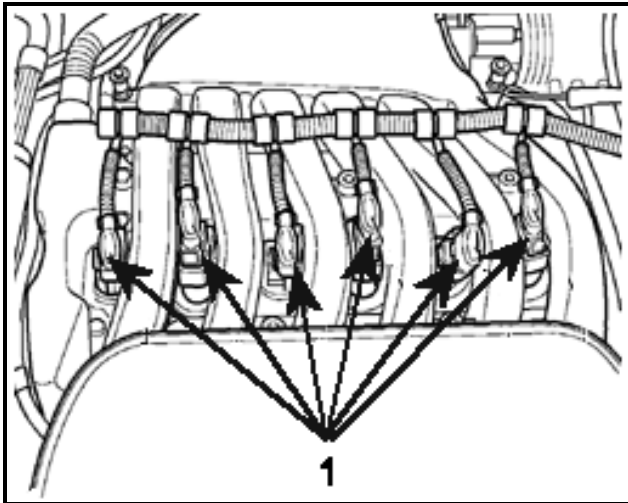

**Section A1 – Wiring Harness Modification for 2002
Model Year Jetta with 2.8 liter Engine
and Automatic Transmission**

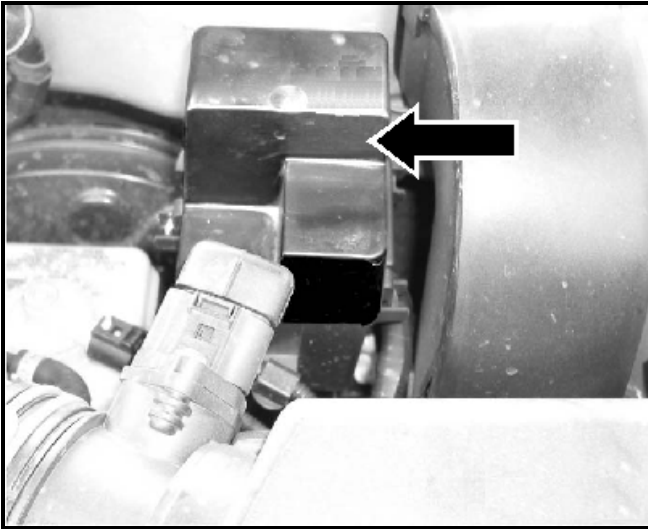

- Disconnect battery ground (GND) cable

⇐ Remove relay cover -arrow- for relay panel
(located next to brake booster) in engine
compartment

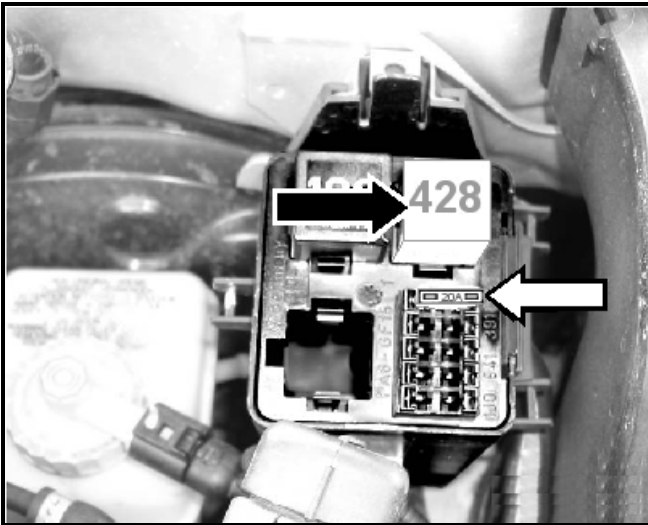

- ⇐ Remove fuse (S51) -white arrow- for vacuum pump
from fuse holder
- ⇐ Remove relay #428 for the main power supply to the
engine control module (ECM) -black arrow-
- Lift out relay panel from the lower housing

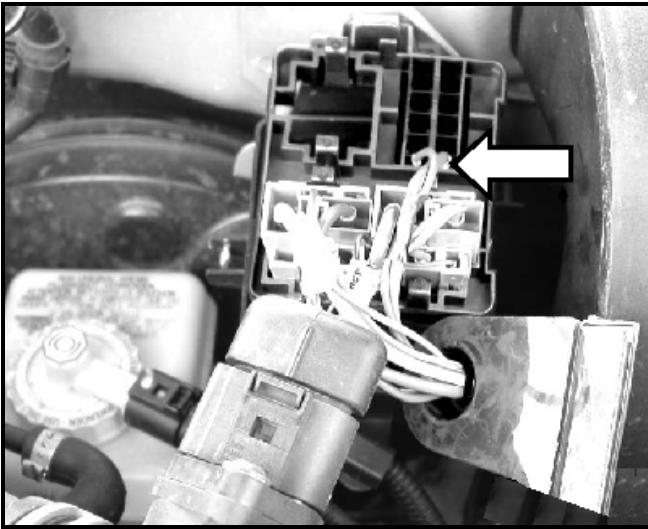

- Turn relay panel over to access wiring to fuse and relay

⇐ Remove large wire from cavity #1 for fuse (S51)
-arrow-

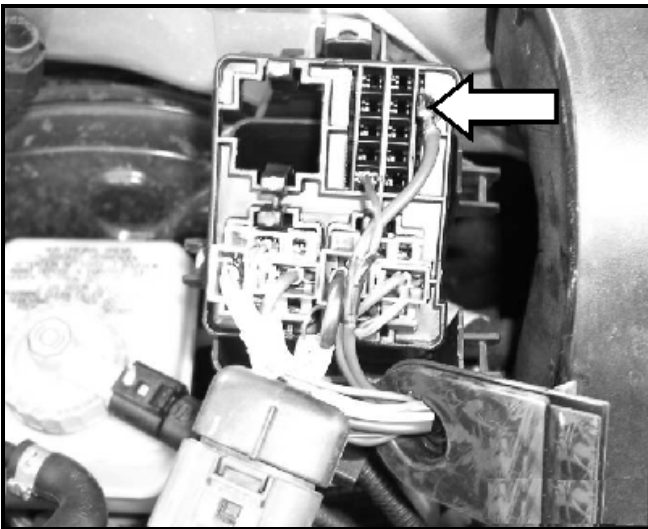

⇐ Illustration to the right shows large wire removed from cavity #1

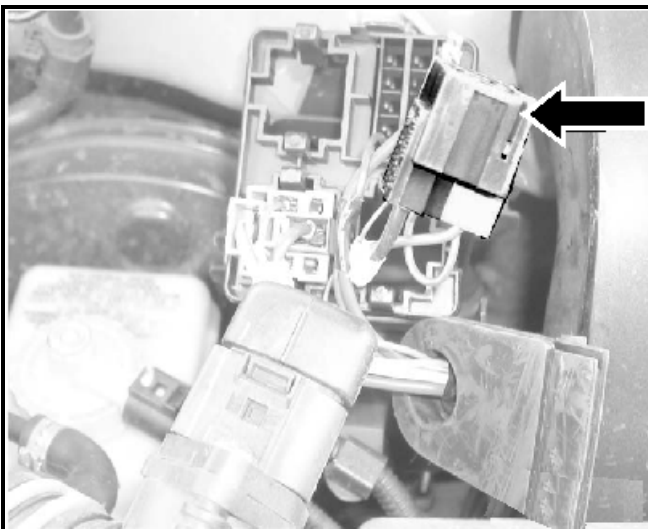

⇐ Remove the red connector block (for relay #428)
-arrow- from the relay panel

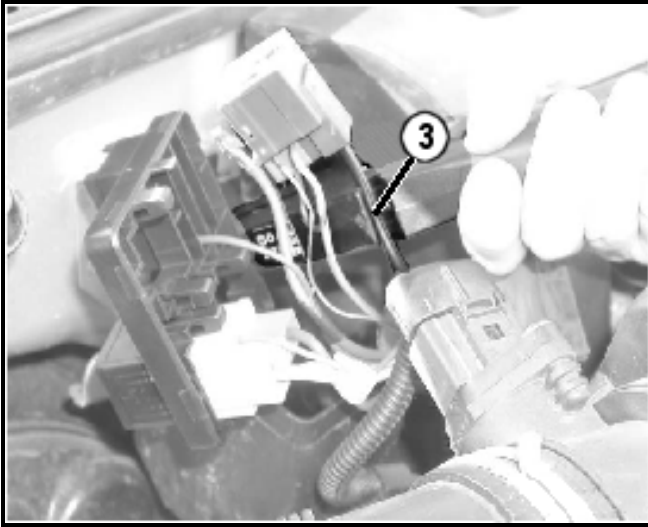

- ⇐ Locate large wire -3- from cavity 2 of the red connector for relay #428 and cut wire approximately 30 mm from the terminal end

Note: Cavity numbers are located on the relay insertion points of the relay connector

- Strip insulation from wire ends using VAS 1978/3 wire strippers from the VAS 1978 repair kit

Note: The illustrations show the large wire still installed in the relay connector housing, it may be easier to remove this terminal from the relay connector housing for the modification

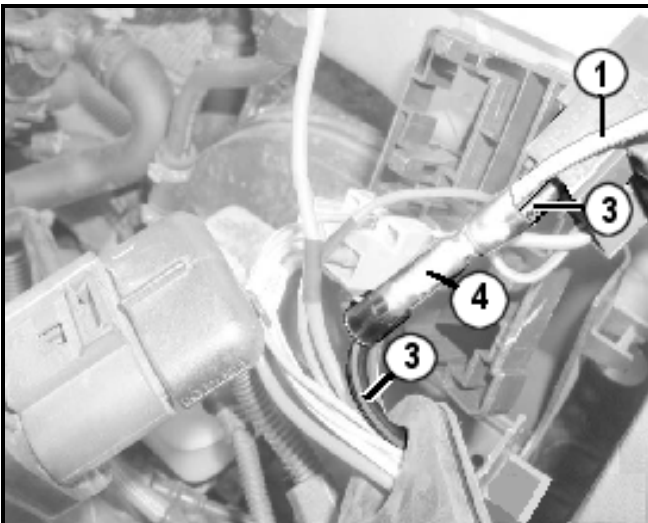

- Using new repair wire (000 979 227), cut approximately 100 mm from the terminal and strip insulation from the wire (other end of the repair wire is not needed)

- ⇐ Insert the new 100mm long repair wire -1- along with the end of the previously cut wire -3- (from connector block cavity 2) into one end of the butt connector -4- (111 971 938 A)

- Crimp the butt connector using the VAS 1978/2 crimper from the VAS 1978 repair kit (one end of spliced is finished)

- ⇐ Insert remaining end of previously cut wire -3- into other end of the butt connector -4- and crimp using the wire crimper

- Seal the butt connector using the electric hot air blower
- If the large wire was removed from the relay connector housing cavity #2 to do this modification, reinstall wire at this time.

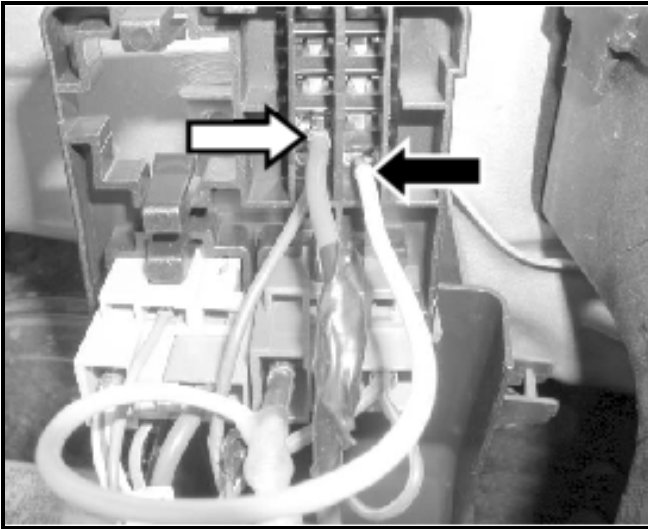

- Install the wire previously removed from the fuse holder (for S51 fuse) cavity #1 into an unused cavity of the fuse holder (this wire is no longer used)
- ⇐ Note: In this illustration, cavity #4 was used –white arrow- however, your vehicle can be different
- ⇐ Install terminal from the new 100 mm repair wire into cavity #1 -black arrow- of the fuse holder
- Reinstall red connector block for relay into relay panel
- Reinstall relay panel into lower housing
- Reinstall relay #428 and fuse (S51) into relay panel
- Reinstall relay cover
- Reconnect battery ground (GND) cable and tighten nut to 6NM (53 in. lbs.)
- Go to Section A2

Section A2 - Repair verification and readiness code setting

- If a wiring harness was modified, turn ignition switch “ON” and OFF” **before** first starting engine, then:
 - Start vehicle and verify correct operation
 - Remove key and wait up to 30 seconds to ensure that the vacuum pump does not run
 - Set engine readiness code and power restoration procedure
- If a wiring harness was not modified and the MIL light was on with cylinder misfire DTCs present, printed and erased, use the VAS5051 and set engine readiness code
- Attach a copy of print out for diagnostic log (showing cylinder misfire DTCs) and readiness code “Test Complete” to repair order

Note: Readiness code setting is not related to this action when other components related to the MIL light are diagnosed and repaired

- ***Destroy and properly dispose of removed ignition coils***

Section B – 1.8 Liter Engine in New Beetle, GTI, Jetta and Passat

IMPORTANT! If the vehicle has a MIL light on, the diagnostic trouble codes (DTCs) must be checked. Only cylinder misfire DTCs related to ignition coil malfunction are covered by this service action. Any other checking, diagnosis or repairs are not part of or covered under this service action.

- If applicable, connect VAS5051 and check DTCs
- Open hood and remove engine cover
- If applicable, remove screw securing vacuum reservoir located above ignition coils
- On New Beetle vehicles, remove plate with turbo

boost valve and move aside

Note: Vacuum lines to reservoir and turbo boost valve do not have to be disconnected

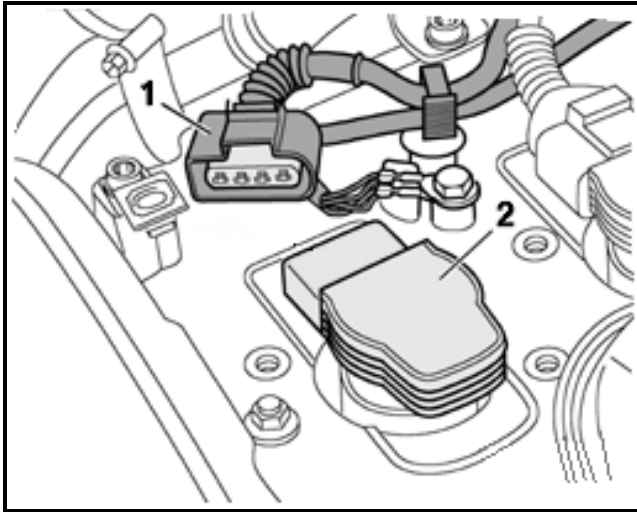

← Disconnect connectors -1- from all ignition coils -2-

NOTE: Only ignition coils that are **not** at the latest production level must be replaced. (Reference "Parts Information" on Page 3)

- Using **Puller T40039**, remove ignition coils

CAUTION: Use of tool T40039 is required to avoid damaging these sensitive components

- Install new ignition coils (06B 905 115J/L) by pressing into cylinder head with hand only

IMPORTANT! Do not use any object to tap ignition coil into position. Do not twist ignition coil when installing.

- Reconnect connectors to ignition coils
- If applicable, reinstall plate with turbo boost valve
- Reinstall vacuum reservoir and secure with bolt
- Reinstall engine cover and close hood
- If the MIL light was on and cylinder misfire DTCs were present, printed and erased, use VAS5051 and set engine readiness code
- Attach a copy of print out for diagnostic log (showing cylinder misfire DTCs) and readiness code "Test Complete" to repair order

Note: Readiness code setting is not related to this action when other components related to the MIL light are diagnosed and repaired

- ***Destroy and properly dispose of removed ignition coils***

Section C – 4.0 Liter Engine in Passat

IMPORTANT! If the vehicle has a MIL light on, the diagnostic trouble codes (DTCs) must be checked. Only cylinder misfire DTCs related to ignition coil malfunction are covered by this service action. Any other checking, diagnosis or repairs are not part of or covered under this service action.

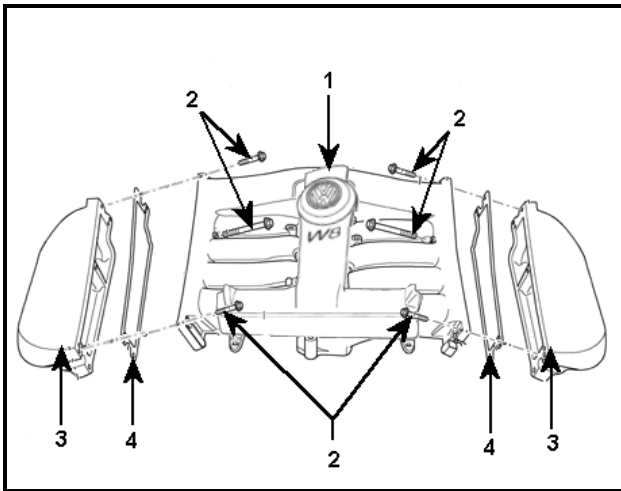

- If applicable, connect VAS5051 and check DTCs

⇐ Open hood and remove center manifold cover -1-

⇐ Remove bolts -2- securing left and right intake manifold side parts -3- and remove side part with gaskets -4-

- Disconnect connectors on all ignition coils

NOTE: Only ignition coils that are **not** at the latest production level must be replaced. (Reference "Parts Information" on Page 3)

- Using **Puller T10094**, remove ignition coils on left and right banks of engine

CAUTION: Use of tool T10094 is required to avoid damaging these sensitive components

- Install new ignition coils (07C 905 115C/D) by pressing into cylinder head by hand only

IMPORTANT! Do not use any object to tap ignition coil into position. Do not twist ignition coil when installing.

- Reconnect connectors to ignition coils
- Reinstall left and right intake manifold side parts with gasket and tighten bolts to 8 Nm. (71 in. lbs.)
- Reinstall center cover and close hood
- If the MIL light was on and cylinder misfire DTCs were present, printed and erased, use VAS5051 and set engine readiness code

- Attach a copy of print out for diagnostic log (showing

cylinder misfire DTCs) and readiness code "Test Complete" to repair order

Note: Readiness code setting is not related to this action when other components related to the MIL light are diagnosed and repaired

- ***Destroy and properly dispose of removed ignition coils***

Section D – 2.8 Liter Engine in Eurovan

IMPORTANT! If the vehicle has a MIL light on, the diagnostic trouble codes (DTCs) must be checked. Only cylinder misfire DTCs related to ignition coil malfunction are covered by this service action. Any other checking, diagnosis or repairs are not part of or covered under this service action.

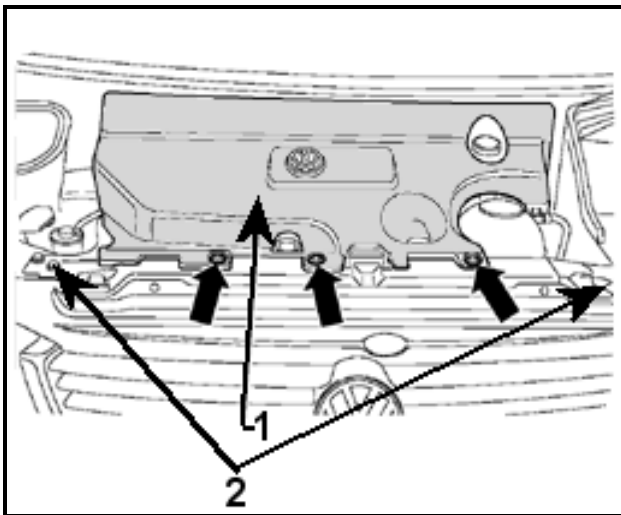

- If applicable, connect VAS5051 and check DTCs
- ⇐ Open hood and remove three T30 torx® screws -arrows- securing engine cover -1- and remove engine cover
- ⇐ Remove bolts -2- on left and right side of vehicle and pivot radiator forward to service position

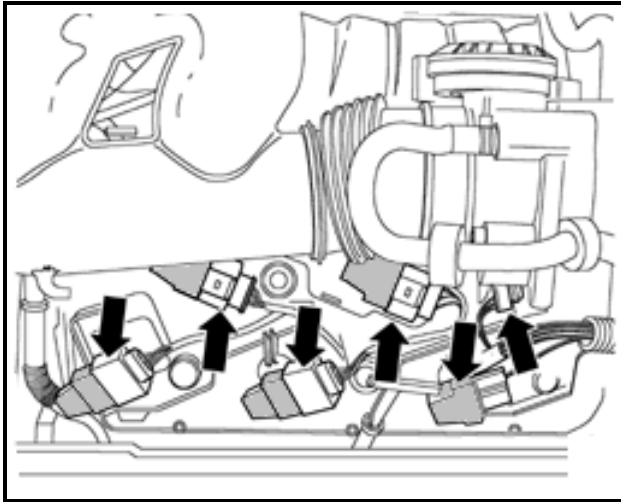

⇐ Disconnect connectors -arrows- from all ignition coils

NOTE: Only ignition coils that are **not** at the latest production level must be replaced. (Reference “Parts Information” on Page 3)

⇐ Using **Puller T10095**, remove ignition coils

CAUTION: Use of tool T10095 is required to avoid damaging these sensitive components

- Install new ignition coils (022 905 100C/F) by pressing into cylinder head by hand only

IMPORTANT! Do not use any object to tap ignition coil into position. Do not twist ignition coil when installing.

- Reconnect connectors to ignition coils
- Move radiator rearward and secure in position with bolts and tighten to 10 Nm (88 in. lbs.)
- Reinstall engine cover and secure with T30 Torx® screws
- If the MIL light was on and cylinder misfire DTCs were present, printed and erased, use VAS5051 and set engine readiness code
- Attach a copy of print out for diagnostic log (showing cylinder misfire DTCs) and readiness code “Test Complete” to repair order

Note: Readiness code setting is not related to this action when other components related to the MIL light are diagnosed and repaired

- **Destroy and properly dispose of removed ignition coils**

Time Requirements/Reimbursement

To ensure prompt reimbursement, be sure to enter, immediately replacement of the ignition coils the applicable reimbursement code listed below.

WG Data Entry Procedure

Claim Type	Repair Code (Damage Code Field)	Time Units	Work Scope
RC	WG12	50 T.U.	<u>2.8L Jetta & GTI Vehicles</u> - Replace ignition coils 6 022 905 100D/G Ignition coil
RC	WG13	110 T.U.	<u>2.8L Jetta & GTI Vehicles</u> - Replace ignition coils - Fault Diagnosis and Set Readiness Code 6 022 905 100D/G Ignition coil
RC	WG14	40 T.U.	<u>1.8T New Beetle, Jetta, GTI & Passat Vehicles</u> - Replace ignition coils 4 06B 905 115J/L Ignition coil
RC	WG15	100 T.U.	<u>1.8T New Beetle, Jetta, GTI & Passat Vehicles</u> - Replace ignition coils - Fault Diagnosis and Set Readiness Code 4 06B 905 115J/L Ignition coil
RC	WG16	110 T.U.	<u>4.0L Passat W8 Vehicles</u> - Replace ignition coils 8 07C 905 115C/D Ignition coil
RC	WG17	170 T.U.	<u>4.0L Passat W8 Vehicles</u> - Replace ignition coils - Fault Diagnosis and Set Readiness Code 8 07C 905 115C/D Ignition coil
RC	WG18	50 T.U.	<u>2.8L EuroVan V6 Vehicles</u> - Replace ignition coils 6 022 905 100C/F Ignition coil
RC	WG19	110 T.U.	<u>2.8L EuroVan V6 Vehicles</u> - Replace ignition coils - Fault Diagnosis and Set Readiness Code 6 022 905 100C/F Ignition coil

The system automatically enters the part number and labor applicable to the above listed codes.

SUBLETS At-A-Glance

	<u>SUB LBR</u>	<u>SUB PTS</u>
P/N 000 979 227 Wire (from the VAS 1978 harness repair kit)		\$ 2.31, if applicable
P/N 111 971 938 A Butt Connector (from the VAS 1978 harness repair kit)		\$ 3.19, if applicable
110 TU for labor on 2002 Jetta automatic wiring harness modification	Add 110 TU at dealer's established labor rate, if applicable	

TO BE PROPERLY REIMBURSED, IT IS IMPERATIVE THAT A SUBLET AMOUNT IS CLAIMED IN THE PROPER SUBLET FIELD AS IDENTIFIED and THAT SUBLET EXPENSE COPIES REMAIN ATTACHED TO YOUR COPY OF THE REPAIR ORDER.

Please note that in some instances vehicles repaired prior to this action already have improved coils (reference "Parts Information" on page 3) and do not require replacement.

The above reimbursement codes assume all coils were replaced on respective vehicles.
Adjustments will be made on claims where improved coil replacement occurred prior to initiation of the WG Service Action.

For vehicles that, according to your information, cannot be corrected, and one of the codes below best describe the reason, please enter into the system one of the codes indicated, as applicable:

WG 20	Customer Refused Repairs
WG 30	Total Loss
WG 40	Vehicle Stolen
WG 50	Vehicle Exported

California Emission Recall Requirements – For California Dealers ONLY

The California Air Resources Board and the Department of Motor Vehicles (DMV) require that emissions-related recalls be completed prior to vehicle registration renewal. **It is, therefore, imperative that upon completion of this recall work that you provide the owner with a signed “Vehicle Emission Recall – Proof of Correction” Certificate.** This certificate, #RC0801 CALEM ALL, will accompany the California owner notification letters. The California Department of Motor Vehicles requires that the size and color of the certificate is identical to the sample provided in this package. Therefore, *if you need additional certificates please order them through Dymnt using the above-mentioned order number.*

Service Action Verification

For verification, **always** check the OTIS View Campaign inquiry screen. The OTIS system is the **only** binding campaign inquiry and verification system; other systems *are not valid and may result in non-payment of a claim.*

Service Help

If you have questions regarding this or any other recall or service action, please call **(800) 741-2919**.

Dealer Personnel Information

Please inform and/or provide a copy of this important communication to every person in your dealership who has campaign-related responsibilities, including parts and accounting personnel.

Thank you for your cooperation.



Maria Cotter
Product Compliance



California Regulations

Dear Mr. Sample,

We are now accelerating the process of replacing all ignition coils in cars potentially affected, whether a malfunction has occurred or not. We are writing to you today to invite you to return to your Volkswagen dealer to have your vehicle updated.

If an ignition coil becomes inoperative, the engine and its electronic controls are designed to keep your vehicle running. Your Malfunction Indicator Lamp (MIL) will illuminate and you may experience some deterioration in performance. This condition may also affect the emissions of your vehicle. You can continue driving and should take your car to the nearest Volkswagen dealer for repair.

The update to your vehicle will take less than one hour. Please call the service department of your Volkswagen dealer to schedule an appointment.

*California regulations require that this repair be completed prior to the time that you renew your vehicle registration. **Please make sure that this repair is completed prior to the renewal of your vehicle registration** and that you furnish proof of repair to the DMV in the form of a copy of the dealer's repair order including a signed "Emission Campaign Performance Authorization" which is enclosed with this letter. Please retain the signed certification form with your vehicle records. DO NOT MAIL THIS FORM to the Department of Motor Vehicles (DMV) unless requested.*

If you are the lessor and registered owner of the vehicle identified in this action, please forward this information immediately by first class mail to the lessee.

If you have already incurred out-of-pocket expenses, please write us at the address below, and we'll be happy to reimburse you. Please include any receipts you might have along with your letter.

Volkswagen of America, Inc.
Attn: Customer Relations
3499 Hamlin Road
Rochester Hills, MI 48309

I want to emphasize that taking care of you, our customer, remains our highest priority and we thank you for your patience. If you have any further questions, or require assistance locating a Volkswagen dealer, please visit vw.com or call us directly at (800) 822-8987.

Thank you for your continued loyalty.

Sincerely,

Frank Maguire
Vice President



49 States

Dear Mr. Sample,

We are now accelerating the process of replacing all ignition coils in cars potentially affected, whether a malfunction has occurred or not. We are writing to you today to invite you to return to your Volkswagen dealer to have your vehicle updated.

If an ignition coil becomes inoperative, the engine and its electronic controls are designed to keep your vehicle running. Your Malfunction Indicator Lamp (MIL) will illuminate and you may experience some deterioration in performance. This condition may also affect the emissions of your vehicle. You can continue driving and should take your car to the nearest Volkswagen dealer for repair.

The update to your vehicle will take less than one hour. Please call the service department of your Volkswagen dealer to schedule an appointment.

If you are the lessor **and registered owner of the vehicle identified in this action, please forward this information immediately by first class mail to the lessee.**

If you have already incurred out-of-pocket expenses, please write us at the address below, and we'll be happy to reimburse you. Please include any receipts you might have along with your letter.

Volkswagen of America, Inc.
Attn: Customer Relations
3499 Hamlin Road
Rochester Hills, MI 48309

I want to emphasize that taking care of you, our customer, remains our highest priority and we thank you for your patience. If you have any further questions, or require assistance locating a Volkswagen dealer, please visit vw.com or call us directly at (800) 822-8987.

Thank you for your continued loyalty.

Sincerely,

Frank Maguire
Vice President

Volkswagen of America, Inc.



3800 Hamlin Road
Auburn Hills, MI 48326

January 2004

Dear Volkswagen Dealer:

This letter is to inform you that the WG Service Action circular has been updated to include additional information on repairing 2003 model year Jetta vehicles with automatic transmissions. We began notifying these owners on or about December 29, 2003.

Please refer to the revised Service Action Circular WG (enclosed) for additional information, including a copy of the customer letter. Please share this information with all personnel with campaign-related responsibilities.

Thank you for your cooperation and assistance in this important matter.

Sincerely,

A handwritten signature in cursive script that reads "Maria Cotter".

Maria Cotter
Product Compliance

**IMPORTANT! Please provide a copy to all personnel with campaign-related responsibilities!
This supercedes the WG Service Action dated December 2003**



Service Action Circular

Code: WG

January 2004

Subject: 2001–2003 Model Year Volkswagen Vehicles Replace Ignition Coils

This is to inform you of the initiation of a service action campaign involving some below identified 2001 through 2003 model year Volkswagen vehicles. This service action pertains to the replacement of the ignition coils.

Problem Description

It is possible that if one of the vehicle's ignition coils fails, rough idling or reduced driving power could occur in addition to illumination of the MIL light.

Remedial Action

Replace ignition coils in each affected vehicle.

Vehicle Identification and VIN Number Ranges

The vehicles affected by this action are identified as follows:

2001 – 2003 New Beetle 1.8T

3VW_ *_ _1C_ 1M000001 - 3VW_ *_ _1C_ 3M414843

(* Vehicles with C in 5th position for model year 2001 only) (* Vehicles with D in 5th position for model years 2001-03) (* Vehicles with E in 5th position for model year 2003 only)

2002 – 2003 Golf (GTI) 1.8T, Jetta 1.8T

9BW_ *_ _1J_ 2_000001 - 9BW_ *_ _1J_ 34032850

(*Vehicles with D or E in 5th position for model year 2002 only) (*Vehicles with E in 5th position for model year 2003)

3VW_ *_ _9M_ 2M000001 - 3VW_ *_ _9M_ 3M051297

(*Vehicles with D or E in 5th position for model year 2002 only) (*Vehicles with E in 5th position for model year 2003)

WVW_ *_ _1J_ 2W000001 - WVW_ *_ _1J_ 3W334992

(*Vehicles with D or E in 5th position for model year 2002 only) (*Vehicles with E in 5th position for model year 2003)

2002 – 2003 GTI V6

9BW_ H_ 1J_ 24000001 - 9BW_ H_ 1J_ 34040002

2002 – 2003 Jetta GLI

3VW_ H_ 9M_ 2M000001 - 3VW_ H_ 9M_ 3M105131

WVW_ H_ 1J_ 2W000001 - WVW_ H_ 1J_ 3W367577

2001 – 2003 Passat 1.8T

WVW_ *_ _3B_ 1E000001 - WVW_ *_ _3B_ 3E175002

WVW_ *_ _3B_ 1P000001 - WVW_ *_ _3B_ 3P265086

(*Vehicles with C or D in 5th position for model year 2001 only) (*Vehicles with D in 5th position for model years 2002/3)

2002 – 2003 Passat W8

WVW_ K_ 3B_ 2P000001 - WVW_ K_ 3B_ 3P263779

WVW_ K_ 3B_ 2E000001 - WVW_ K_ 3B_ 3E177001

2001 – 2003 EuroVan V6

WV_ _B_ 70_ 1H000519 - WV_ _B_ 70_ 3H091264

Owner Notification Mailing

Volkswagen began the initial mailings to inform all known owners of this service action campaign by first class mail on or about June 6, 2003.

Vehicle Allocation

Each dealer will receive a computer printout listing containing VINs and owner information of owners which have been notified.

Parts Information

You will receive automatic parts allocations based on owner notification mailings to owners located within your area of responsibility. Do not place an order on your own until further notice.

<i>New Beetle 1.8T</i>	-	<i>06B 905 115J/L</i>
<i>Golf(GTI), Jetta 1.8T</i>	-	<i>06B 905 115J/L</i>
<i>GTI, Jetta GLI</i>	-	<i>022 905 100D/G</i>
<i>Passat 1.8T</i>	-	<i>06B 905 115J/L</i>
<i>Passat W8</i>	-	<i>07C 905 115C/D</i>
<i>EuroVan V6</i>	-	<i>022 905 100C/F</i>

Work Procedure

Objective: This procedure describes changing the ignition coils on 1.8 liter & 2.8 liter engines in New Beetle, GTI & Jetta vehicles, a wire harness modification for 2002 & 2003 Jetta vehicles having a 2.8 liter engine with an automatic transmission, changing the ignition coils on 1.8 liter & 4.0 liter engines in Passat vehicles, and on 2.8 liter engines in Eurovan vehicles.

Special Tools

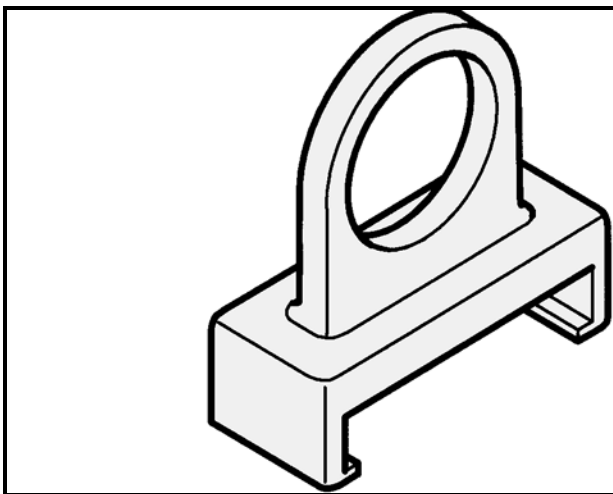

⇐ **Puller T40039** - must be used to avoid damaging ignition coils during removal

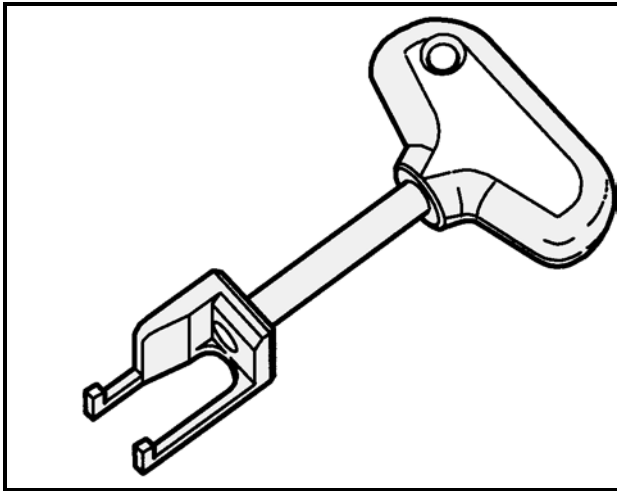

← **Puller T10095** - must be used to avoid damaging ignition coils during removal

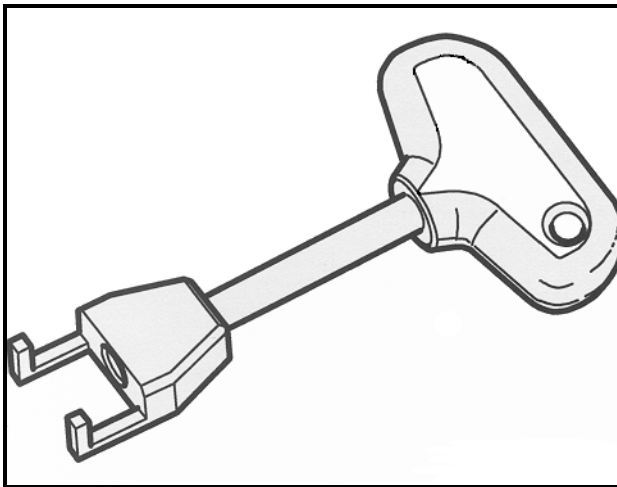

← **Puller T10094** - must be used to avoid damaging ignition coils during removal

- **VAS 1978** - Wiring Harness Repair Kit

Parts: In addition to the ignition coils, other parts are needed on some vehicles. These parts are listed below:

For 2002 Jetta with automatic transmission and 2.8 liter engine:

<u>Quantity</u>	<u>Part Number</u>	<u>Part Name</u>
1	000 979 227	Repair Wire (from the VAS 1978 harness repair kit)
1	111 971 938 A	Butt Connector, (from the VAS 1978 harness repair kit)

For 2003 Jetta with automatic transmission and 2.8 liter engine:

<u>Quantity</u>	<u>Part Number</u>	<u>Part Name</u>
1	1J0 971 658 N	Harness Kit

Note: If assembled harness kit (1J0 971 658 N) is not available from parts, then the individual parts listed below can be assembled.

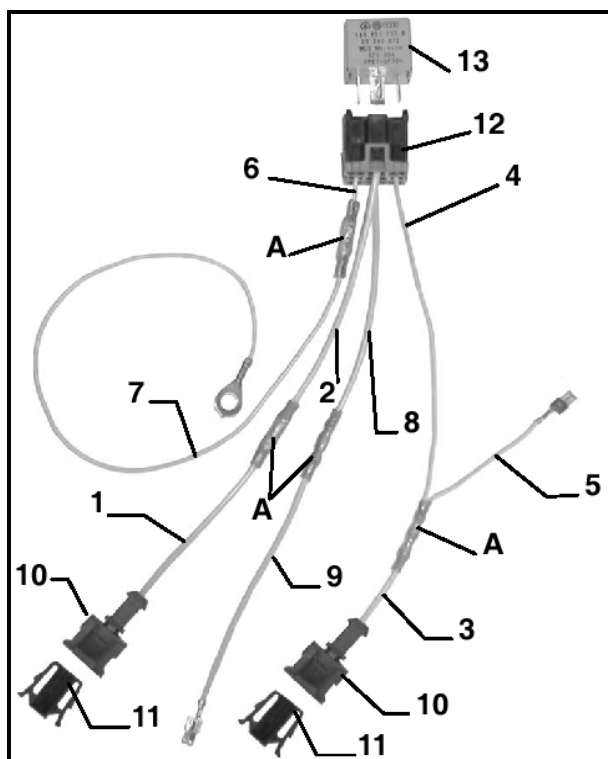

Item	Part Number	Qty.	Description
A	111 971 939 B	4	Butt Connector (Blue)*
1	000 979 220	1	Repair Wire*
2,8,9	000 927 227	2	Repair Wire*
3	000 979 130	1	Repair Wire*
4,6	000 979 114	1	Repair Wire*
5	000 979 135	1	Repair Wire*
7	000 979 137	1	Repair Wire*
10	191 972 761	2	Terminal Housing
11/11A	191 972 751	2	Terminal Housing
12	443 937 527	1	Relay Housing
13	141 951 253 B	1	Relay

* Parts available from the VAS 1978 harness repair kit

Relay, relay housing and terminal housings must be ordered through parts

Work Sequence:

Section A - 2.8 liter engine in Jetta and GTI vehicles

Section B - 1.8 liter engine in New Beetle, GTI, Jetta and Passat vehicles

Section C - 4.0 liter engine in Passat vehicles

Section D - 2.8 liter engine in Eurovan vehicles

Section A – 2.8 Liter Engine in Jetta and GTI

IMPORTANT! If the vehicle has a MIL light on, the diagnostic trouble codes (DTCs) must be checked. Only cylinder misfire DTCs related to ignition coil malfunction are covered by this service action. Any other checking, diagnosis or repairs are not part of or covered under this service action.

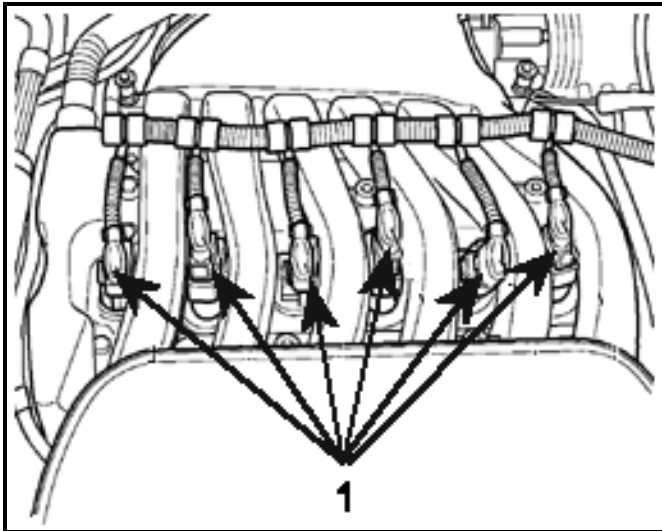

- If applicable, connect VAS5051 and check DTCs

- Open hood and remove engine cover

⇐ Disconnect connector from all ignition coils -1-

- Using **Puller T10095**, remove ignition coils

CAUTION: Use of tool T10095 is required to avoid damaging these sensitive components

NOTE: Only ignition coils that are **not** at the latest production level must be replaced. (Reference “Parts Information” on Page 3)

- Install new ignition coils (022 905 100 D/G) by pressing into cylinder head by hand only

IMPORTANT! Do not use any object to tap ignition coil into position. Do not twist ignition coil when installing.

- Reconnect connectors to ignition coils
- Reinstall engine cover
- If vehicle is a 2002 model year Jetta with automatic transmission go to Section A1
- If vehicle is a 2003 model year Jetta with automatic transmission go to Section A2

If vehicle is a Jetta or GTI with manual transmission go to Section A3

**Section A1 – Wiring Harness Modification on 2002
Model Year Jetta Vehicles having a
2.8 Liter Engine with an Automatic
Transmission**

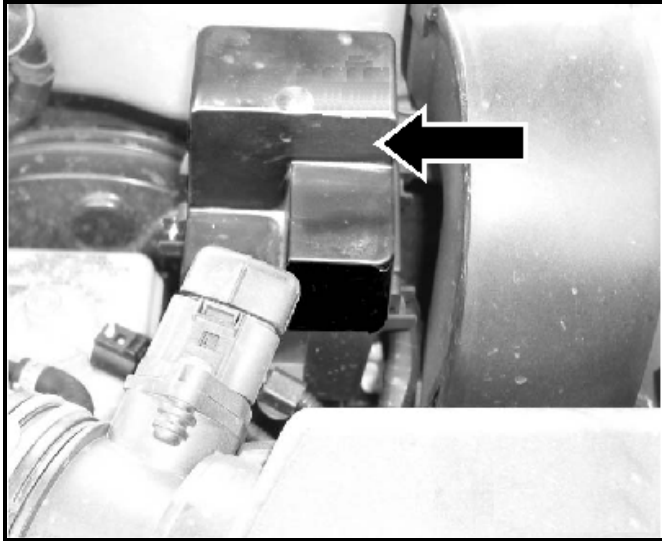

- Disconnect battery ground (GND) cable
- ⇐ Remove relay cover -arrow- for relay panel (located next to brake booster) in engine compartment

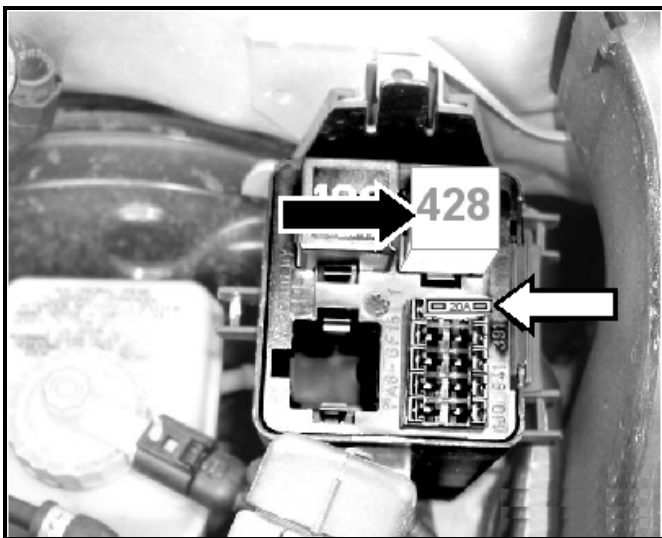

- ⇐ Remove fuse (S51) -white arrow- for vacuum pump from fuse holder
- ⇐ Remove relay #428 for the main power supply to the engine control module (ECM) -black arrow-
- Lift out relay panel from the lower housing

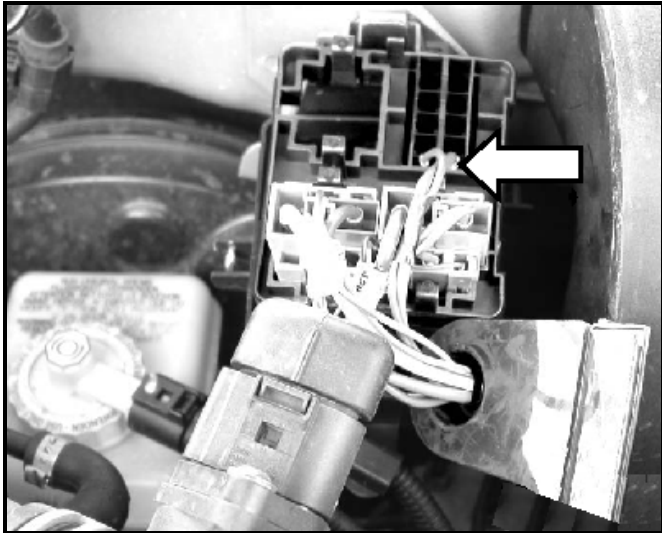

- Turn relay panel over to access wiring to fuse and relay

⇐ Remove large wire from cavity #1 for fuse (S51)
-arrow-

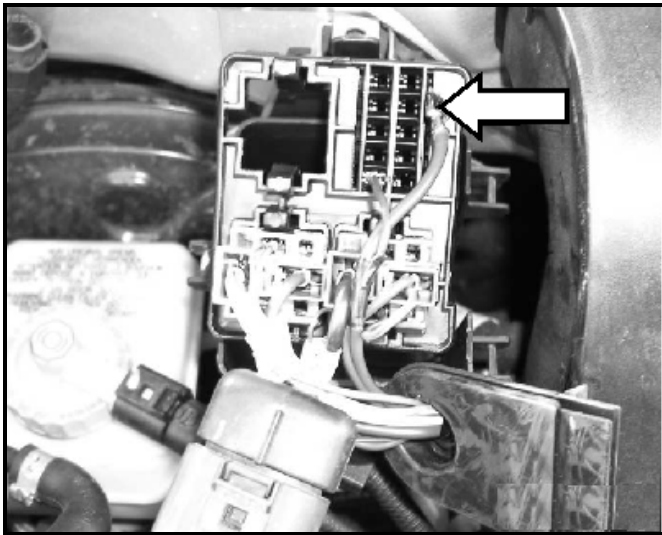

⇐ Illustration to the right shows large wire –arrow-
removed from cavity #1

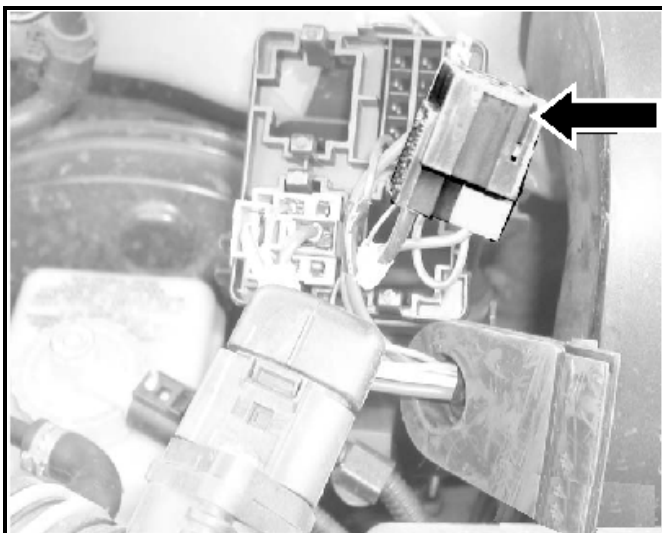

⇐ Remove red connector block (for relay #428)
-arrow- from the relay housing

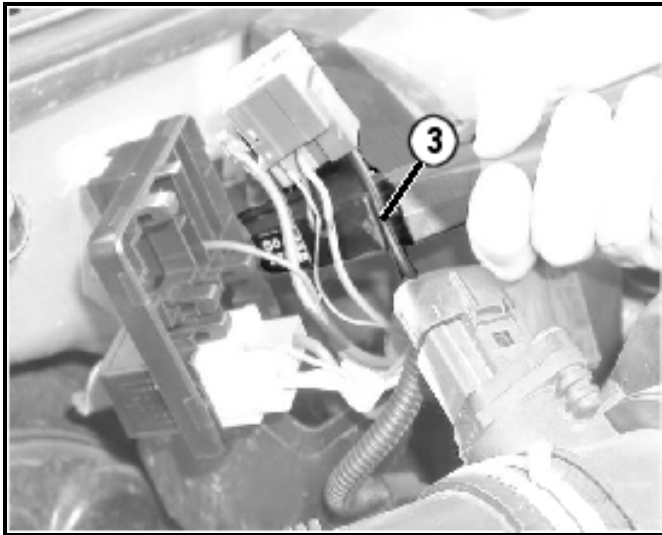

- ⇐ Locate large wire -3- from cavity 2 of the red connector for relay #428 and cut wire approximately 30 mm from terminal

Note: Cavity numbers are located on the connector at the terminal insertion points

- Strip insulation from wire ends using VAS 1978/3 wire strippers from the VAS 1978 repair kit

Note: The illustrations show the large wire installed in the relay connector housing. It may be easier to remove this terminal from the relay connector housing for the following modification

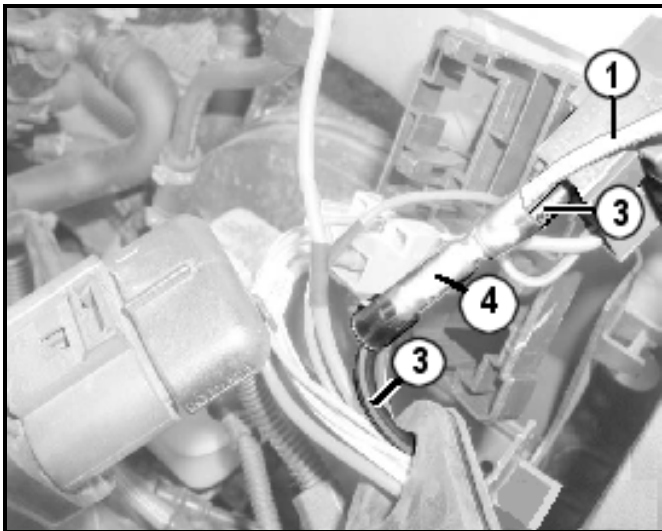

- Using new repair wire (000 979 227), cut wire approximately 100 mm from the terminal and strip the insulation from the wire (other end of the repair wire is not needed)

- ⇐ Insert the new 100 mm long repair wire -1- along with the end (30 mm length) of the previously cut wire -3- (from connector block cavity 2) into one end of a butt connector -4- (111 971 938 A)

- Crimp the butt connector using the VAS 1978/2 crimper from the VAS 1978 repair kit
- Insert remaining end of previously cut wire -3- into the other end of the butt connector -4- and crimp using the wire crimper
- Seal the butt connector using the electric hot air blower
- If the large wire was removed from the relay connector housing cavity #2 to do this modification, reinstall wire at this time

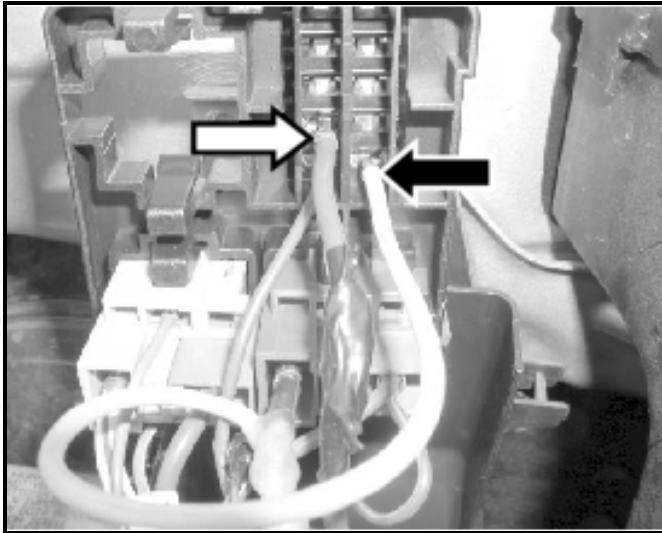

- Install the wire previously removed from the fuse holder (for fuse S51) cavity #1 into an unused cavity of the fuse holder (this wire is no longer used)

⇐ Note: In this illustration, cavity #4 was used - white arrow- however, your vehicle may be different

- ⇐ Install terminal from the 100 mm repair wire into the cavity #1 -black arrow- of the fuse holder

- Reinstall red connector block for relay into relay panel
- Reinstall relay panel into lower housing
- Reinstall relay #428 and fuse (S51) into relay panel
- Reinstall relay cover
- Reconnect battery ground (GND) cable and tighten nut to 6 Nm (53 in. lbs.)
- Go to Section A3

Section A2 – Wiring Harness Modification on 2003 Model Year Jetta Vehicles having a 2.8 liter engine with an Automatic Transmission

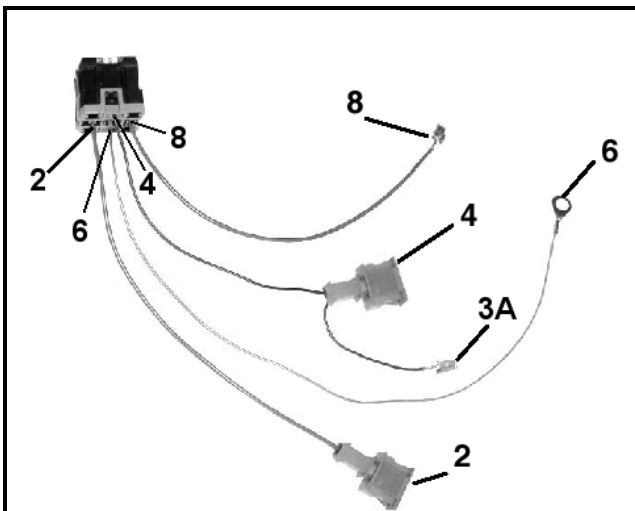

Note: Use harness kit (1J0 971 658 N). If not obtainable, the harness can be assembled. Some parts are in the VAS 1978 wiring harness repair kit other parts need to be ordered (Reference “Parts” on page 3.) Instructions for harness assembly are in Section A4

⇐ **Important! The terminal ends on the wire harness from the kit or from the assembled harness are shown to correspond to the terminal connection numbers on the relay connector**

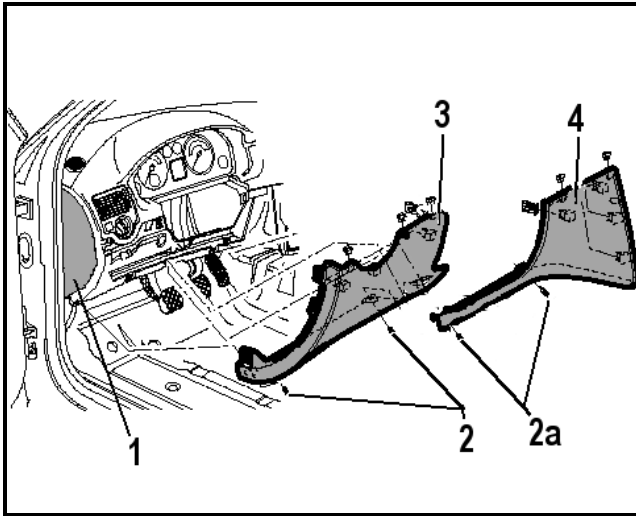

- ⇐ Open drivers door, remove instrument panel side cover -1-
- ⇐ Remove 2 screws -2- unclip trim panel -3- and remove
- ⇐ Remove 2 screws -2a- unclip trim panel -4 and remove

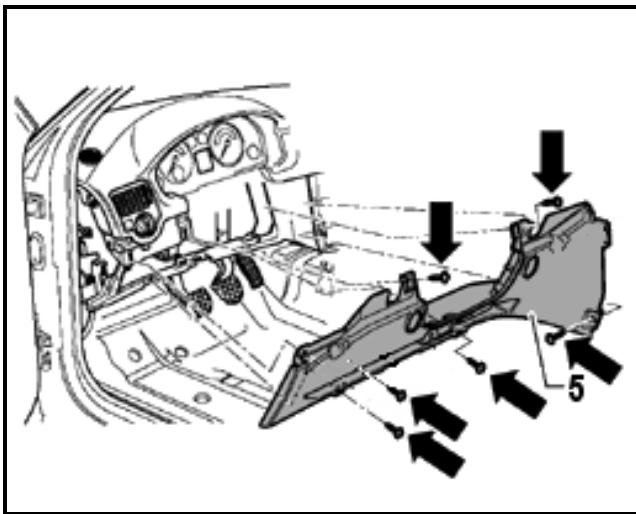

- ⇐ Remove (6) screws -arrows- and remove reinforcement -5-

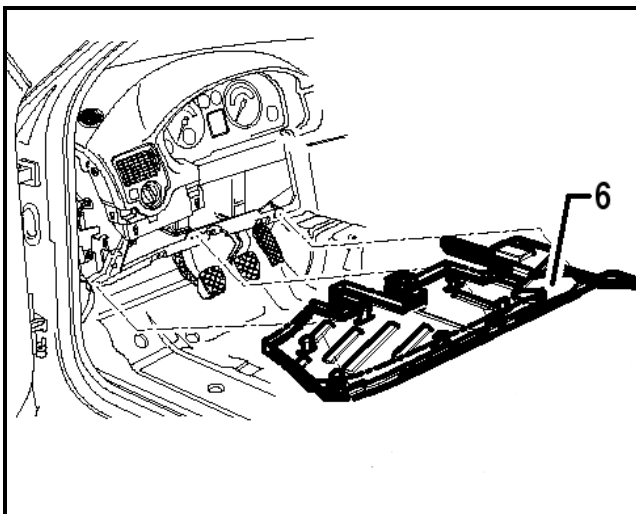

- ⇐ Unclip and remove lower cover -6- by sliding rearward out of clips

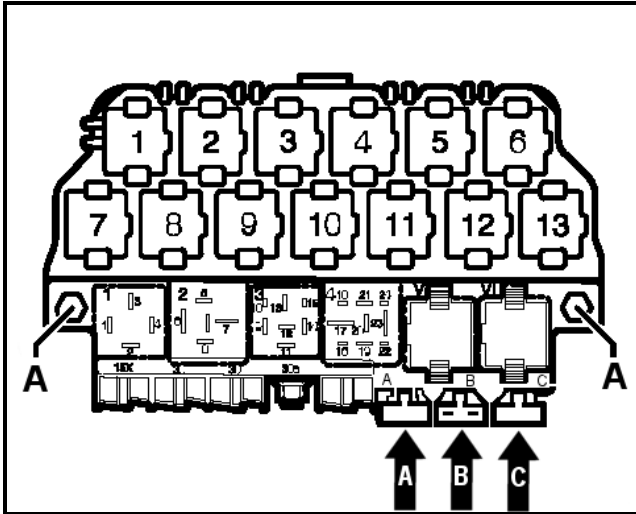

- ⇐ Using a volt meter, check the terminal contacts of the 15 amp fuse in position B -arrow- for (12 volts or B+ power) and make note of terminal position in fuse housing
- Under hood, remove battery cover and disconnect battery ground (GND) cable
- ⇐ Remove fuse/relay holders -A- and -C- (arrows) at the bottom of the lower relay panel
- ⇐ Remove fuse holder -B- from the bottom of lower relay panel -arrow- and remove fuse from holder
- ⇐ Remove (2) nuts -A- and pull lower relay carrier rearward and down to remove

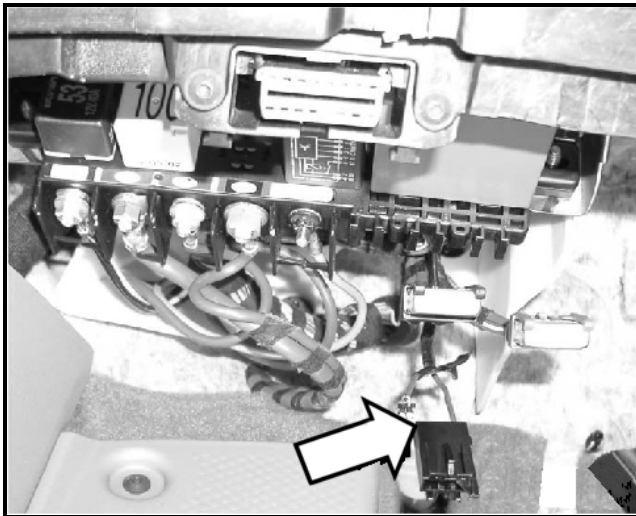

- ⇐ Remove the B+ terminal (as previously found) from fuse holder B -arrow-

Note: The illustration shows the wire removed from position #2, however, your vehicle could be different

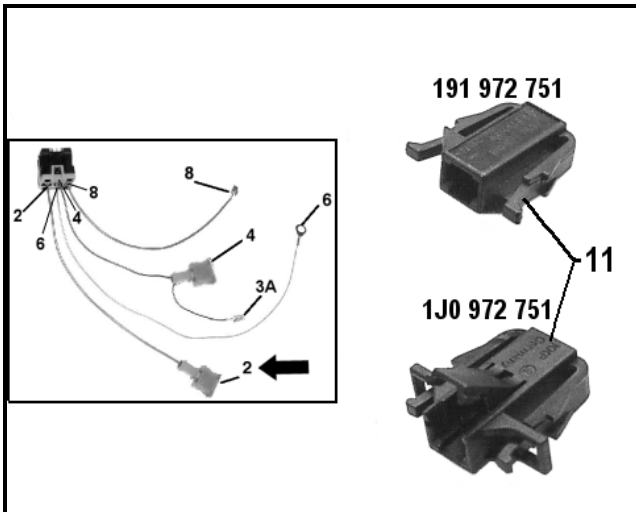

- ⇐ Insert the B+ terminal (removed from fuse holder) into terminal housing -11- (191 972 751 or 1J0 972 751)

Note: The terminal housing 1J0 972 751 comes with the wiring harness assembly.

Important! To insert the B+ terminal into the 1J0 972 751 housing, the side clip needs to be opened

Note: This terminal housing -11- will be connected to a terminal housing -2- on the new wiring harness later in the procedure

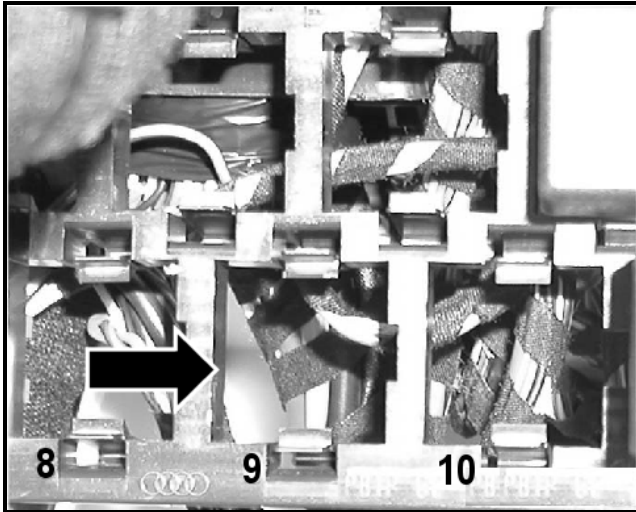

⇐ From the rear of the upper half of the relay panel, insert the new relay connector block on the new harness assembly into position #9 -arrow-

Note: The new relay must be removed from the relay connector on the new harness assembly before installing

- Route wires 2, 6 & 8 on the new harness assembly behind the fuse/relay panels

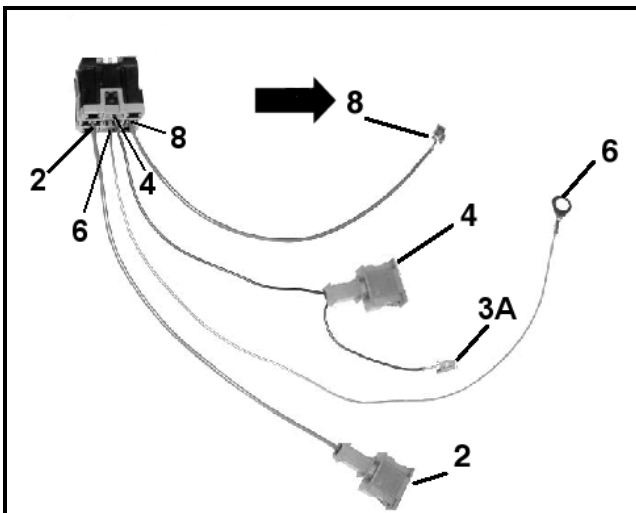

⇐ Locate terminal -8- (arrow) on the new wiring harness assembly

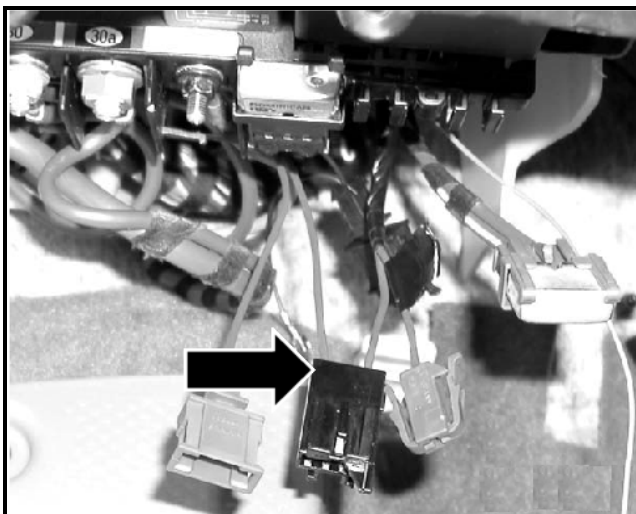

⇐ Insert terminal 8 on the new wire harness into the empty (B+) location in the 15 amp fuse holder -arrow-

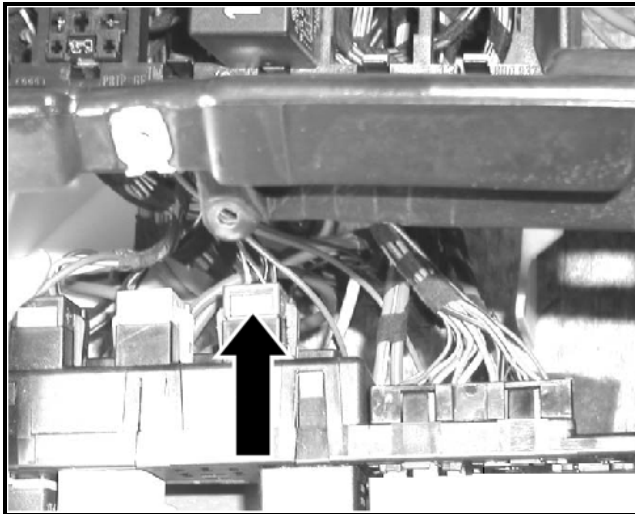

⇐ Remove (red) connector block -arrow- (for relay position 3) on reverse side of lower relay carrier

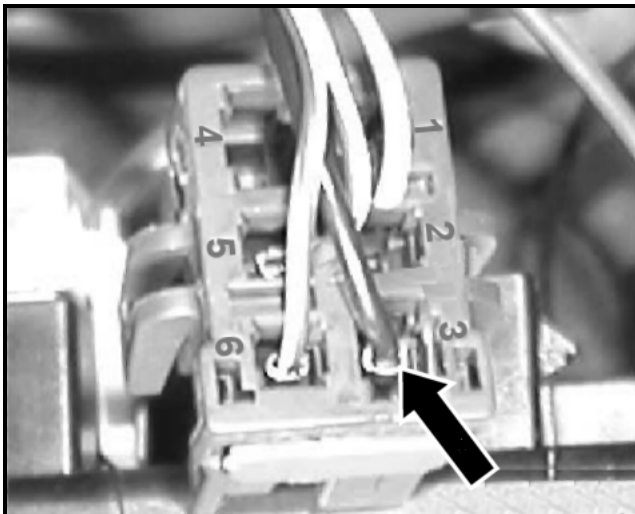

⇐ Remove terminal from position number 3 -arrow- of red connector block

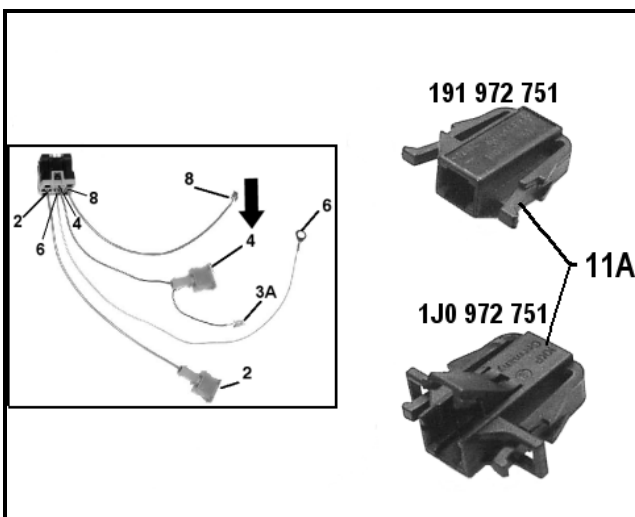

⇐ Insert this terminal -3- into connector housing -11A- (191 972 751 or 1J0 972 751)

Note: The terminal housing 1J0 972 751 comes with the wiring harness assembly.

Important! To insert terminal -3- into the 1J0 972 751 housing, the side clip needs to be opened

⇐ Connect the housing -11A- to the connector housing -4- on the new harness assembly

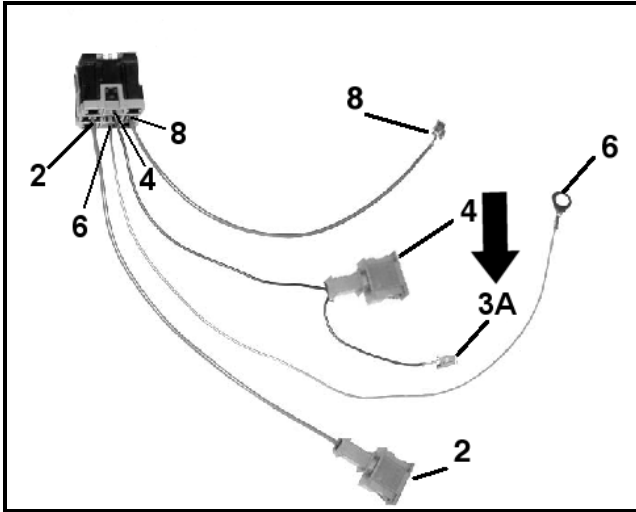

⇐ Locate terminal -3A- (arrow) (short wire from connector housing -4-) on new harness assembly

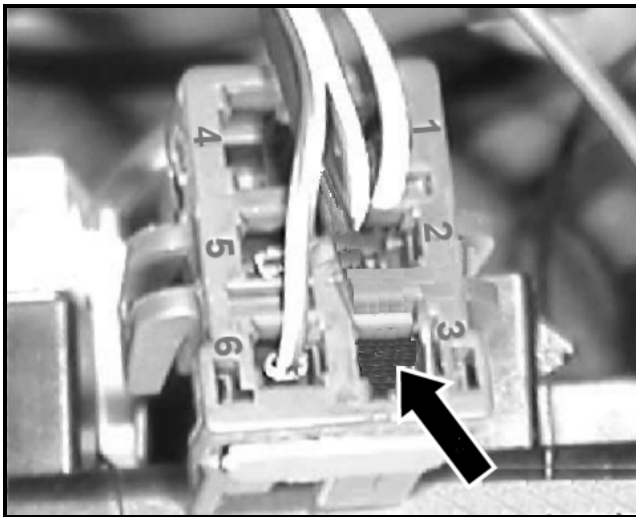

- ⇐ Insert terminal -3A- into the empty position number 3 -arrow- of red connector
- Reinstall red connector block to reverse side of relay panel (behind relay position 3)

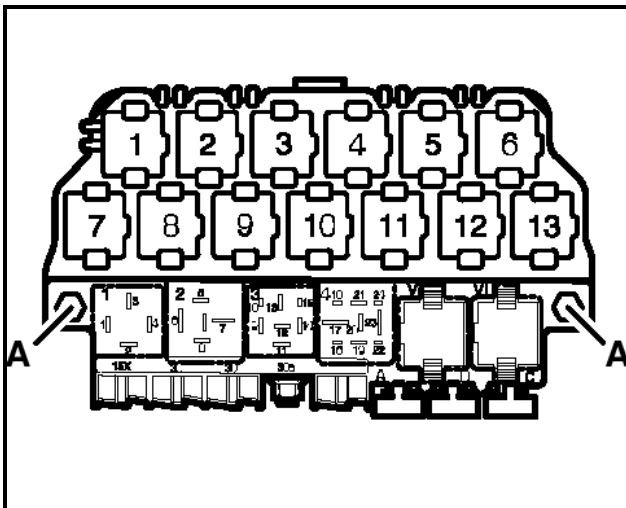

⇐ Reinstall relay carriers, secure with (2) nuts -A- and tighten to 2 Nm (18 in. lbs.)

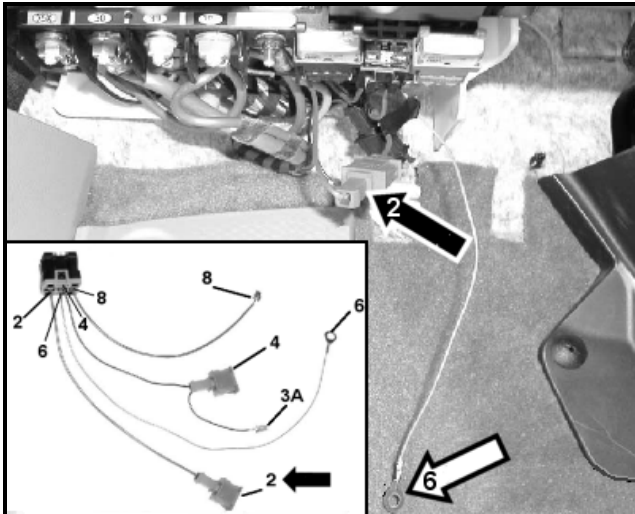

- ⇐ Insert the connector -11- (contains terminal removed from B+ fuse connector at the start of this procedure) to connector -2- (arrow) on the new wire harness assembly
- Reinstall fuse holder to location B on the lower relay block
- Reinstall 15 amp fuse
- Reinstall fuse/relay holders -A- & -C- into proper location on lower relay block
- ⇐ Locate ground (GND) wire -6- (eyelet terminal on the new wiring harness assembly)

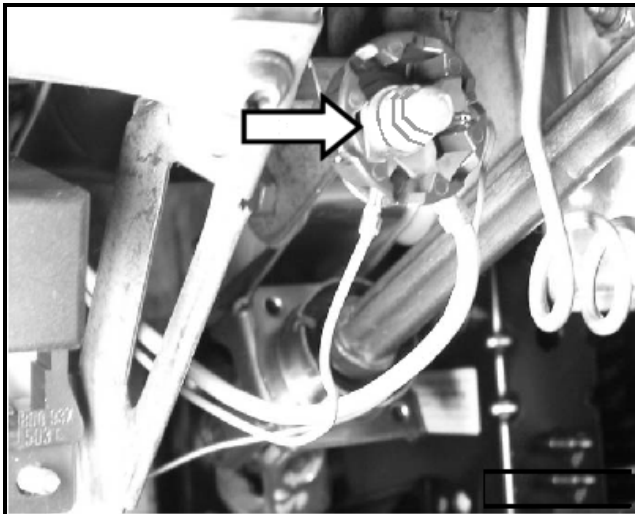

- ⇐ Remove cap nut at ground point -arrow- near steering column, install ground wire eyelet -6- from new harness assembly, secure with cap nut and tighten to 6 Nm (53 in. lbs.)

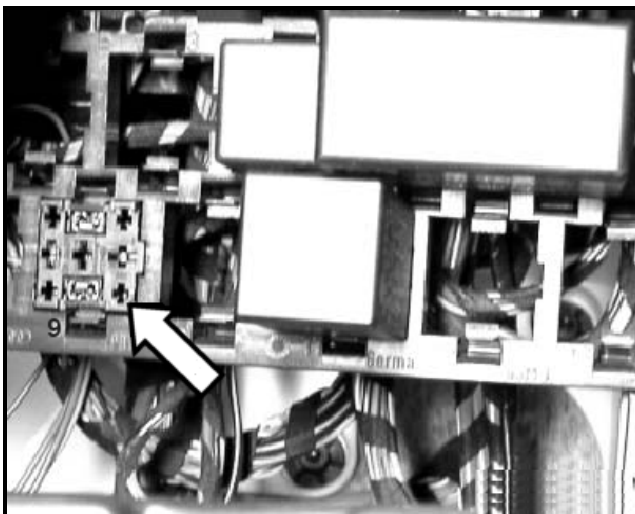

- ⇐ Install new (141 951 253 B) relay into upper relay block position 9 -arrow-
- Reinstall instrument panel lower cover
- Reinstall reinforcement and secure with (6) screws
- Reinstall lower trim panels
- Reinstall instrument panel side cover
- Reconnect battery ground (GND) cable and tighten to 6 Nm (53 in. Lbs)
- Reinstall battery cover
- Proceed to Section A3

Section A3 - Repair verification and readiness code setting

- If a wiring harness was modified, turn ignition switch “ON” and OFF” **before** first starting engine, then:
 - Start vehicle and verify correct operation
 - Remove key and wait up to 30 seconds to ensure that the vacuum pump does not run
 - Set engine readiness code and power restoration procedure
- If a wiring harness was not modified and the MIL light was on with cylinder misfire DTCs present, printed and erased, use VAS5051 and set engine readiness code
- Attach a copy of print out for diagnostic log (showing cylinder misfire DTCs) and readiness code “Test Complete” to repair order

Note: Readiness code setting is not related to this action when other components related to the MIL light are diagnosed and repaired

- ***Destroy and properly dispose of removed ignition coils***

Section A4 – Wiring Harness Assembly

Note: This section is needed only if the wiring harness assembly 1J0 971 658 N is not obtainable.

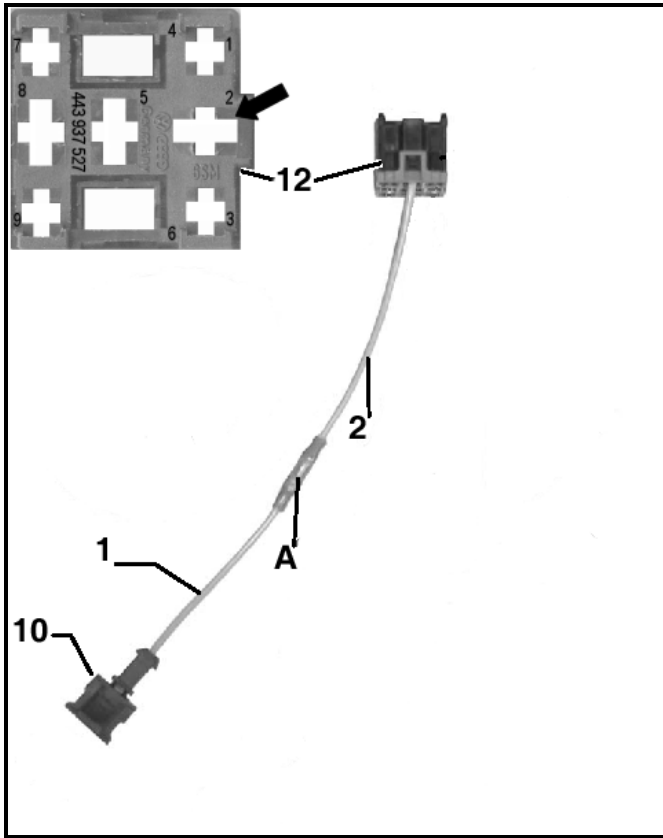

- ⇐ Using a repair wire -2- (000 927 227), cut wire approx. 100 mm from terminal, insert wire in butt connector -A- (111 971 939 B) and crimp butt connector with the VAS 1978/2 crimpmer
- ⇐ Using a repair wire -1- (000 979 220), cut wire approx. 100 mm from terminal, insert wire in butt connector -A- and crimp butt connector
- Seal the butt connector using the electric hot air blower from the VAS 1978 repair kit
- ⇐ Insert terminal end of wire -2- into position 2 -arrow- of relay connector -12- and wire end -1- into a terminal housing -10- (191 972 761)

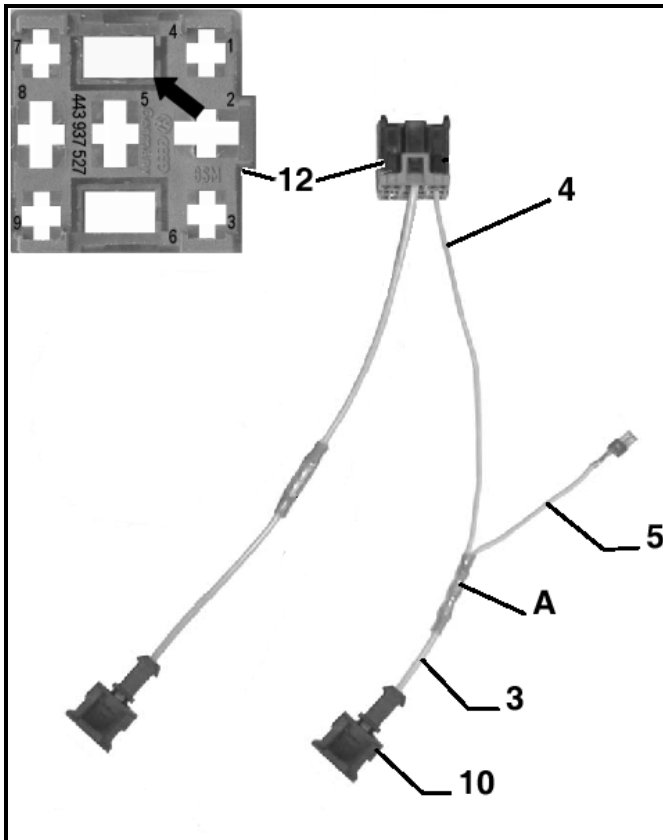

- ⇐ Using a repair wire -4- (000 979 114), cut wire approx. 150 mm from terminal
- ⇐ Using a repair wire -5- (000 979 135), cut wire approx. 80 mm from terminal
- ⇐ Insert ends of wire -4- & -5- into butt connector A- and crimp connector
- ⇐ Using a repair wire -3- (000 979 130), cut wire approx. 70 mm from terminal, insert wire in butt connector -A- and crimp butt connector
- Seal the butt connector using the electric hot air blower
- ⇐ Insert terminal end of wire -4- into position 4 arrow- of relay connector -12- and terminal end of wire -5- into terminal housing -10- (191 972 761)

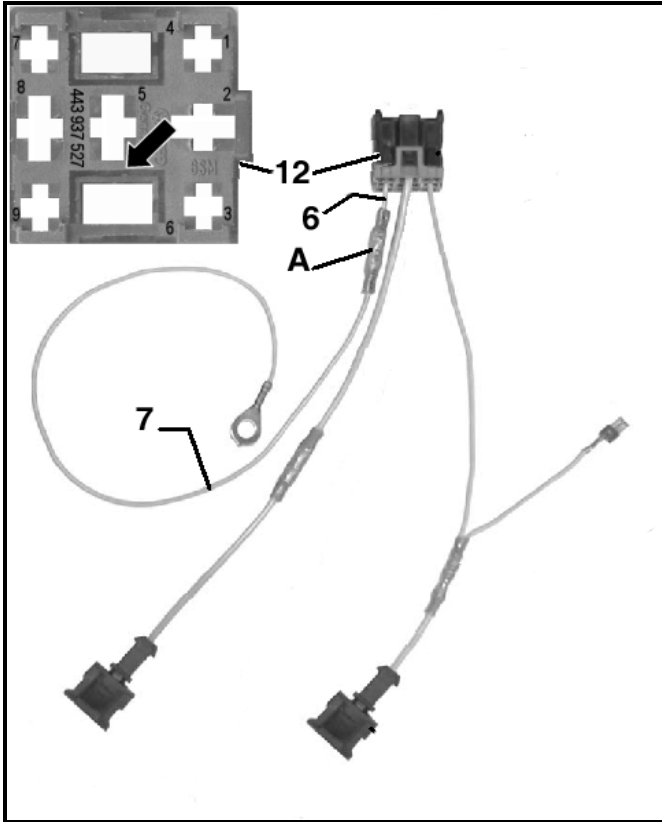

- ⇐ Using repair wire -6- (000 979 114), cut wire approx. 30 mm from terminal, insert into butt connector -A- and crimp connector
- ⇐ Using repair wire -7- (000 979 137), cut wire approx. 330 mm from eyelet, insert into butt connector -A- and crimp connector
- Seal the butt connector using the electric hot air blower
- ⇐ Insert terminal end of wire -6- into position 6 of relay connector -12-

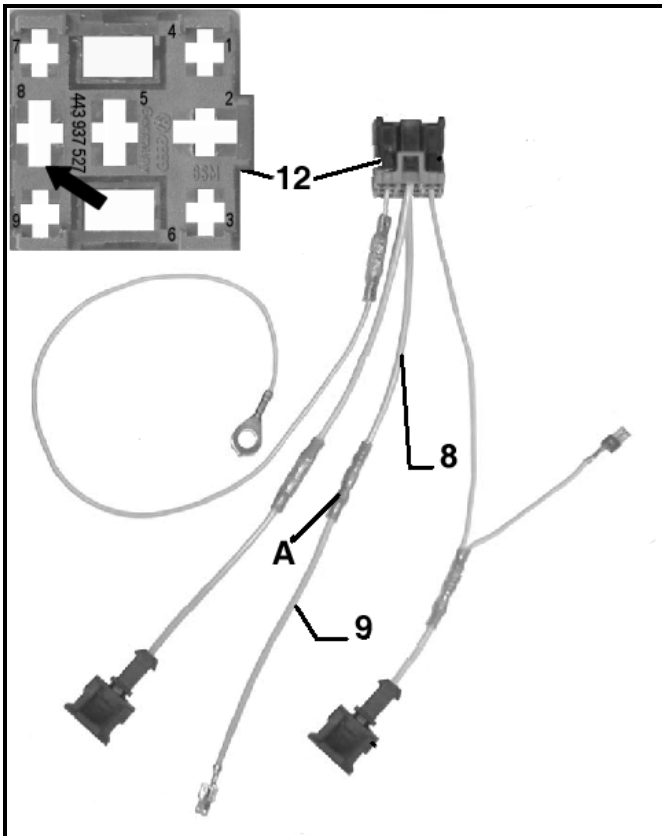

- ⇐ Using repair wire -8- (000 979 227), cut wire approx. 110 mm from eyelet, insert into butt connector -A- and crimp connector
- ⇐ Using repair wire -9- (000 979 227), cut wire approx. 110 mm from eyelet, insert into butt connector -A- and crimp connector
- Seal both ends of the butt connector using the electric hot air blower
- ⇐ Insert terminal end of wire -8- into position 8 of relay connector -12-
- Go to Section A2 for harness installation

Section B – 1.8 Liter Engine in New Beetle, GTI, Jetta and Passat

IMPORTANT! If the vehicle has a MIL light on, the diagnostic trouble codes (DTCs) must be checked. Only cylinder misfire DTCs related to ignition coil malfunction are covered by this service action. Any other checking, diagnosis or repairs are not part of or covered under this service action.

- If applicable, connect VAS5051 and check DTCs
- Open hood and remove engine cover
- If applicable, remove screw securing vacuum reservoir located above ignition coils
- On New Beetle vehicles, remove plate with turbo boost valve and move aside

Note: Vacuum lines to reservoir and turbo boost valve do not have to be disconnected

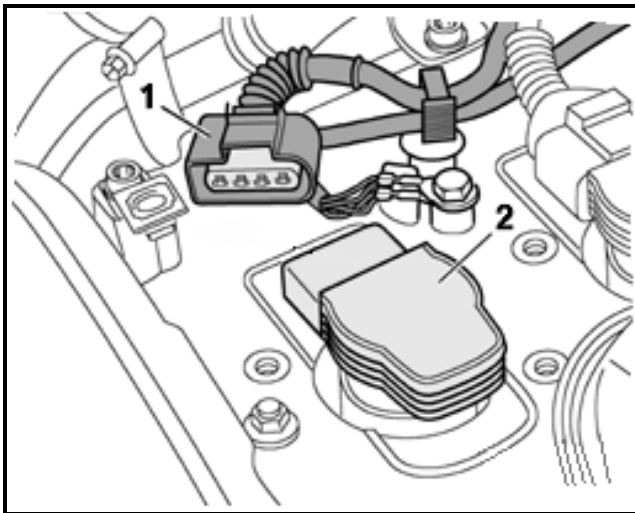

← Disconnect connectors -1- from all ignition coils -2-

NOTE: Only ignition coils that are **not** at the latest production level must be replaced. (Reference "Parts Information" on Page 3)

- Using **Puller T40039**, remove ignition coils

CAUTION: Use of tool T40039 is required to avoid damaging these sensitive components

- Install new ignition coils (06B 905 115J/L) by pressing into cylinder head with hand only

IMPORTANT! Do not use any object to tap ignition coil into position. Do not twist ignition coil when installing.

- Reconnect connectors to ignition coils
- If applicable, reinstall plate with turbo boost valve

- Reinstall vacuum reservoir and secure with bolt
- Reinstall engine cover and close hood
- If the MIL light was on and cylinder misfire DTCs were present, printed and erased, use VAS5051 and set engine readiness code
- Attach a copy of print out for diagnostic log (showing cylinder misfire DTCs) and readiness code "Test Complete" to repair order

Note: Readiness code setting is not related to this action when other components related to the MIL light are diagnosed and repaired

- ***Destroy and properly dispose of removed ignition coils***

Section C – 4.0 Liter Engine in Passat

IMPORTANT! If the vehicle has a MIL light on, the diagnostic trouble codes (DTCs) must be checked. Only cylinder misfire DTCs related to ignition coil malfunction are covered by this service action. Any other checking, diagnosis or repairs are not part of or covered under this service action.

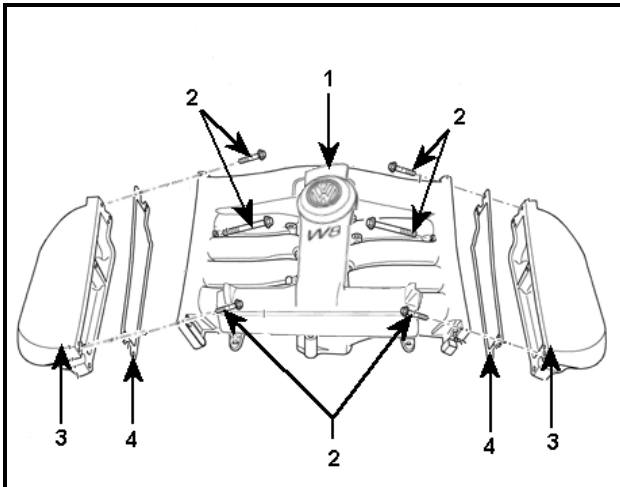

- If applicable, connect VAS5051 and check DTCs
- ⇐ Open hood and remove center manifold cover -1-
- ⇐ Remove bolts -2- securing left and right intake manifold side parts -3- and remove side part with gaskets -4-
- Disconnect connectors on all ignition coils

NOTE: Only ignition coils that are **not** at the latest production level must be replaced. (Reference "Parts Information" on Page 3)

- Using **Puller T10094**, remove ignition coils on left and right banks of engine

CAUTION: Use of tool T10094 is required to avoid damaging these sensitive components

- Install new ignition coils (07C 905 115C/D) by pressing into cylinder head by hand only

IMPORTANT! Do not use any object to tap ignition coil into position. Do not twist ignition coil when installing.

- Reconnect connectors to ignition coils
- Reinstall left and right intake manifold side parts with gasket and tighten bolts to 8 Nm. (71 in. lbs.)
- Reinstall center cover and close hood
- If the MIL light was on and cylinder misfire DTCs were present, printed and erased, use VAS5051 and set engine readiness code
- Attach a copy of print out for diagnostic log (showing cylinder misfire DTCs) and readiness code "Test Complete" to repair order

Note: Readiness code setting is not related to this action when other components related to the MIL light are diagnosed and repaired

- ***Destroy and properly dispose of removed ignition coils***

Section D – 2.8 Liter Engine in Eurovan

IMPORTANT! If the vehicle has a MIL light on, the diagnostic trouble codes (DTCs) must be checked. Only cylinder misfire DTCs related to ignition coil malfunction are covered by this service action. Any other checking, diagnosis or repairs are not part of or covered under this service action.

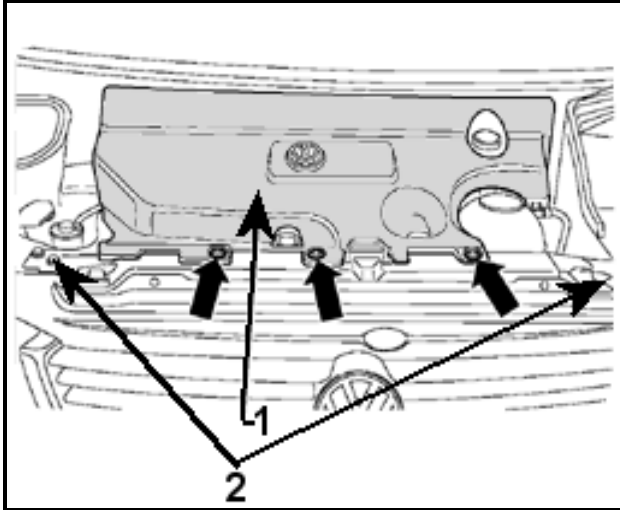

- If applicable, connect VAS5051 and check DTCs

⇐ Open hood and remove three T30 torx® screws -arrows- securing engine cover -1- and remove engine cover

⇐ Remove bolts -2- on left and right side of vehicle and pivot radiator forward to service position

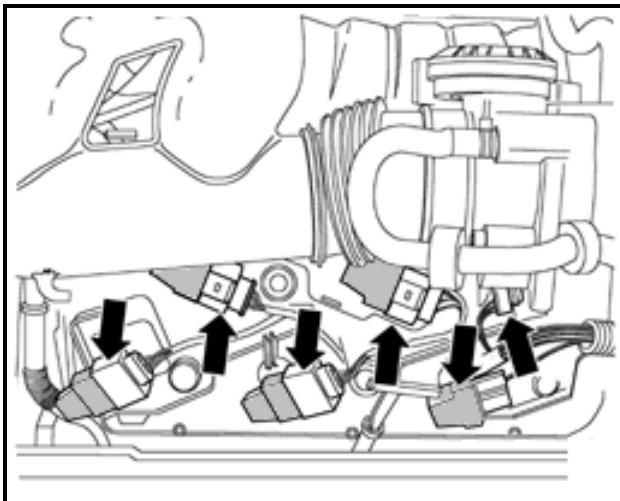

⇐ Disconnect connectors -arrows- from all ignition coils

NOTE: Only ignition coils that are **not** at the latest production level must be replaced. (Reference “Parts Information” on Page 3)

⇐ Using **Puller T10095**, remove ignition coils

CAUTION: Use of tool T10095 is required to avoid damaging these sensitive components

- Install new ignition coils (022 905 100C/F) by pressing into cylinder head by hand only

IMPORTANT! Do not use any object to tap ignition coil into position. Do not twist ignition coil when installing.

- Reconnect connectors to ignition coils
- Move radiator rearward and secure in position with bolts and tighten to 10 Nm (88 in. lbs.)

- Reinstall engine cover and secure with T30 Torx® screws
- If the MIL light was on and cylinder misfire DTCs were present, printed and erased, use VAS5051 and set engine readiness code
- Attach a copy of print out for diagnostic log (showing cylinder misfire DTCs) and readiness code “Test Complete” to repair order

Note: Readiness code setting is not related to this action when other components related to the MIL light are diagnosed and repaired

Destroy and properly dispose of removed ignition coils

Time Requirements/Reimbursement

To ensure prompt reimbursement, be sure to enter, immediately replacement of the ignition coils the applicable reimbursement code listed below.

WG Data Entry Procedure

Claim Type	Repair Code (Damage Code Field)	Time Units	Work Scope
RC	WG12	50 T.U.	<u>2.8L Jetta & GTI Vehicles</u> - Replace ignition coils 6 022 905 100D/G Ignition coil
RC	WG13	110 T.U.	<u>2.8L Jetta & GTI Vehicles</u> - Replace ignition coils - Fault Diagnosis and Set Readiness Code 6 022 905 100D/G Ignition coil
RC	WG14	40 T.U.	<u>1.8T New Beetle, Jetta, GTI & Passat Vehicles</u> - Replace ignition coils 4 06B 905 115J/L Ignition coil
RC	WG15	100 T.U.	<u>1.8T New Beetle, Jetta, GTI & Passat Vehicles</u> - Replace ignition coils - Fault Diagnosis and Set Readiness Code 4 06B 905 115J/L Ignition coil
RC	WG16	110 T.U.	<u>4.0L Passat W8 Vehicles</u> - Replace ignition coils 8 07C 905 115C/D Ignition coil
RC	WG17	170 T.U.	<u>4.0L Passat W8 Vehicles</u> - Replace ignition coils - Fault Diagnosis and Set Readiness Code 8 07C 905 115C/D Ignition coil
RC	WG18	50 T.U.	<u>2.8L EuroVan V6 Vehicles</u> - Replace ignition coils 6 022 905 100C/F Ignition coil
RC	WG19	110 T.U.	<u>2.8L EuroVan V6 Vehicles</u> - Replace ignition coils - Fault Diagnosis and Set Readiness Code 6 022 905 100C/F Ignition coil

The system automatically enters the part number and labor applicable to the above listed codes.

SUBLETS At-A-Glance

	<u>SUB LBR</u>	<u>SUB PTS</u>
P/N 000 979 227 Wire (from the VAS 1978 harness repair kit)		\$ 2.31, if applicable
P/N 111 971 938 A Butt Connector (from the VAS 1978 harness repair kit)		\$ 3.19, if applicable
110 TU for labor on 2002 Jetta automatic wiring harness modification	Add 110 TU at dealer's established labor rate, if applicable	
130 TU for labor on 2003 Jetta automatic to install new wiring harness assembly	Add 130 TU at dealer's established labor rate, if applicable	
165 TU for labor on 2003 Jetta automatic to assemble and install new wiring harness assembly	Add 130 TU at dealer's established labor rate, if applicable	

TO BE PROPERLY REIMBURSED, IT IS IMPERATIVE THAT A SUBLET AMOUNT IS CLAIMED IN THE PROPER SUBLET FIELD AS IDENTIFIED and THAT SUBLET EXPENSE COPIES REMAIN ATTACHED TO YOUR COPY OF THE REPAIR ORDER.

Please note that in some instances vehicles repaired prior to this action already have improved coils (reference "Parts Information" on page 3) and do not require replacement.

The above reimbursement codes assume all coils were replaced on respective vehicles.
Adjustments will be made on claims where improved coil replacement occurred prior to initiation of the WG Service Action.

For vehicles that, according to your information, cannot be corrected, and one of the codes below best describe the reason, please enter into the system one of the codes indicated, as applicable:

WG 20	Customer Refused Repairs
WG 30	Total Loss
WG 40	Vehicle Stolen
WG 50	Vehicle Exported

California Emission Recall Requirements – For California Dealers ONLY

The California Air Resources Board and the Department of Motor Vehicles (DMV) require that emissions-related recalls be completed prior to vehicle registration renewal. **It is, therefore, imperative that upon completion of this recall work that you provide the owner with a signed "Vehicle Emission Recall – Proof of Correction" Certificate.** This certificate, #RC0801 CALEM ALL, will accompany the California owner notification letters. The California Department of Motor Vehicles requires that the size and color of the certificate is identical to the sample provided in this package. Therefore, *if you need additional certificates please order them through Dymet using the above-mentioned order number.*

Service Action Verification

For verification, **always** check the OTIS View Campaign inquiry screen. The OTIS system is the **only** binding campaign inquiry and verification system; other systems *are not valid and may result in non-payment of a claim*.

Service Help

If you have questions regarding this or any other recall or service action, please call **(800) 741-2919**.

Dealer Personnel Information

Please inform and/or provide a copy of this important communication to every person in your dealership who has campaign-related responsibilities, including parts and accounting personnel.

Thank you for your cooperation.

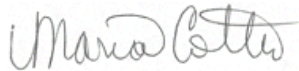

Maria Cotter
Product Compliance



California Regulations

Dear Mr. Sample,

We are now accelerating the process of replacing all ignition coils in cars potentially affected, whether a malfunction has occurred or not. We are writing to you today to invite you to return to your Volkswagen dealer to have your vehicle updated.

If an ignition coil becomes inoperative, the engine and its electronic controls are designed to keep your vehicle running. Your Malfunction Indicator Lamp (MIL) will illuminate and you may experience some deterioration in performance. This condition may also affect the emissions of your vehicle. You can continue driving and should take your car to the nearest Volkswagen dealer for repair.

The update to your vehicle will take less than one hour. Please call the service department of your Volkswagen dealer to schedule an appointment.

*California regulations require that this repair be completed prior to the time that you renew your vehicle registration. **Please make sure that this repair is completed prior to the renewal of your vehicle registration** and that you furnish proof of repair to the DMV in the form of a copy of the dealer's repair order including a signed "Emission Campaign Performance Authorization" which is enclosed with this letter. Please retain the signed certification form with your vehicle records. DO NOT MAIL THIS FORM to the Department of Motor Vehicles (DMV) unless requested.*

If you are the lessor and registered owner of the vehicle identified in this action, please forward this information immediately by first class mail to the lessee.

If you have already incurred out-of-pocket expenses, please write us at the address below, and we'll be happy to reimburse you. Please include any receipts you might have along with your letter.

Volkswagen of America, Inc.
Attn: Customer Relations
3499 Hamlin Road
Rochester Hills, MI 48309

I want to emphasize that taking care of you, our customer, remains our highest priority and we thank you for your patience. If you have any further questions, or require assistance locating a Volkswagen dealer, please visit vw.com or call us directly at (800) 822-8987.

Thank you for your continued loyalty.

Sincerely,

Frank Maguire
Vice President



49 States

Dear Mr. Sample,

We are now accelerating the process of replacing all ignition coils in cars potentially affected, whether a malfunction has occurred or not. We are writing to you today to invite you to return to your Volkswagen dealer to have your vehicle updated.

If an ignition coil becomes inoperative, the engine and its electronic controls are designed to keep your vehicle running. Your Malfunction Indicator Lamp (MIL) will illuminate and you may experience some deterioration in performance. This condition may also affect the emissions of your vehicle. You can continue driving and should take your car to the nearest Volkswagen dealer for repair.

The update to your vehicle will take less than one hour. Please call the service department of your Volkswagen dealer to schedule an appointment.

If you are the lessor **and registered owner of the vehicle identified in this action, please forward this information immediately by first class mail to the lessee.**

If you have already incurred out-of-pocket expenses, please write us at the address below, and we'll be happy to reimburse you. Please include any receipts you might have along with your letter.

Volkswagen of America, Inc.
Attn: Customer Relations
3499 Hamlin Road
Rochester Hills, MI 48309

I want to emphasize that taking care of you, our customer, remains our highest priority and we thank you for your patience. If you have any further questions, or require assistance locating a Volkswagen dealer, please visit vw.com or call us directly at (800) 822-8987.

Thank you for your continued loyalty.

Sincerely,

Frank Maguire
Vice President

**IMPORTANT! Please provide a copy to all personnel with campaign-related responsibilities!
This circular supercedes the WG Service Action dated April 2004.**



Service Action Circular

Code: **WG**

June 2004

**Subject: 2001–2003 Model Year Volkswagen Vehicles
Replace Ignition Coils**

This is to inform you of the initiation of a service action campaign involving some below identified 2001 through 2003 model year Volkswagen vehicles. This service action pertains to the replacement of the ignition coils.

Problem Description

It is possible that if one of the vehicle's ignition coils fails, rough idling or reduced driving power could occur in addition to illumination of the MIL light.

Remedial Action

Replace ignition coils in each affected vehicle.

Vehicle Identification and VIN Number Ranges

The vehicles affected by this action are identified as follows:

2001 – 2003 New Beetle 1.8T

3VW_ *_ _1C_ _1M000001 - 3VW_ *_ _1C_ 3M414843

(* Vehicles with C in 5th position for model year 2001 only) (* Vehicles with D in 5th position for model years 2001-03) (* Vehicles with E in 5th position for model year 2003 only)

2002 – 2003 Golf (GTI) 1.8T, Jetta 1.8T

9BW_ *_ _1J_ 2_000001 - 9BW_ *_ _1J_ 34032850

(*Vehicles with D or E in 5th position for model year 2002 only) (*Vehicles with E in 5th position for model year 2003)

3VW_ *_ _9M_ 2M000001 - 3VW_ *_ _9M_ 3M051297

(*Vehicles with D or E in 5th position for model year 2002 only) (*Vehicles with E in 5th position for model year 2003)

WVW_ *_ _1J_ 2W000001 - WVW_ *_ _1J_ 3W334992

(*Vehicles with D or E in 5th position for model year 2002 only) (*Vehicles with E in 5th position for model year 2003)

2002 – 2003 GTI V6

9BW_ H_ 1J_ 24000001 - 9BW_ H_ 1J_ 34040002

2002 – 2003 Jetta GLI

3VW_ H_ 9M_ 2M000001 - 3VW_ H_ 9M_ 3M105131

WVW_ H_ 1J_ 2W000001 - WVW_ H_ 1J_ 3W367577

2001 – 2003 Passat 1.8T

WVW_ *_ _3B_ 1E000001 - WVW_ *_ _3B_ 3E175002

WVW_ *_ _3B_ 1P000001 - WVW_ *_ _3B_ 3P265086

(*Vehicles with C or D in 5th position for model year 2001 only) (*Vehicles with D in 5th position for model years 2002/3)

2002 – 2003 Passat W8

WVW_ K_ 3B_ 2P000001 - WVW_ K_ 3B_ 3P263779

WVW_ K_ 3B_ 2E000001 - WVW_ K_ 3B_ 3E177001

2001 – 2003 EuroVan/Rialta V6

WV_ _B_ 70_ 1H000519 - WV_ _B_ 70_ 3H091264

Owner Notification Mailing

Volkswagen began the initial mailings to inform all known owners of this service action campaign by first class mail on or about June 6, 2003.

Vehicle Allocation

Each dealer will receive a computer printout listing containing VINs and owner information of owners which have been notified.

Parts Information

Review "Material Comments" in Parts on Command to place additional orders.

Note: Only ignition coils that are **not** one of the production levels shown below must be replaced.

<i>New Beetle 1.8T</i>	-	<i>06B 905 115J/L</i>
<i>Golf(GTI), Jetta 1.8T</i>	-	<i>06B 905 115J/L</i>
<i>GTI, Jetta GLI</i>	-	<i>022 905 100D/G/K</i>
<i>Passat 1.8T</i>	-	<i>06B 905 115J/L</i>
<i>Passat W8</i>	-	<i>07C 905 115C/D</i>
<i>EuroVan/Rialta V6</i>	-	<i>022 905 100C/F/J</i>

Work Procedure

Objective: This procedure describes changing the ignition coils on 1.8 liter & 2.8 liter engines in New Beetle, GTI & Jetta vehicles, a wire harness modification for 2002 & 2003 Jetta vehicles having a 2.8 liter engine with an automatic transmission, changing the ignition coils on 1.8 liter & 4.0 liter engines in Passat vehicles, and on 2.8 liter engines in EuroVan/Rialta vehicles.

Special Tools

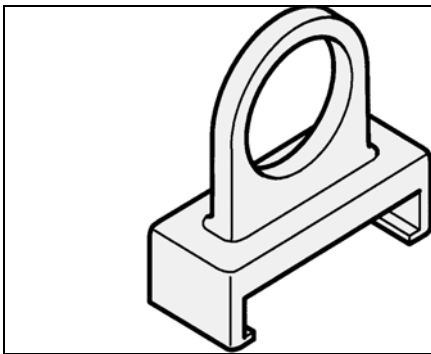

← **Puller T40039** - must be used to avoid damaging ignition coils during removal

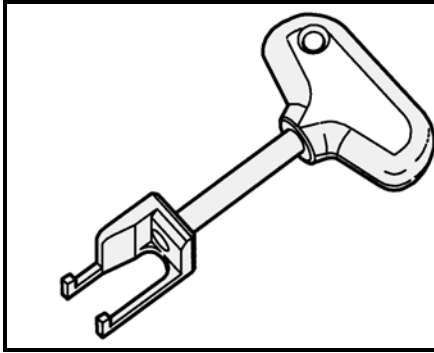

⇐ **Puller T10095** - must be used to avoid damaging ignition coils during removal

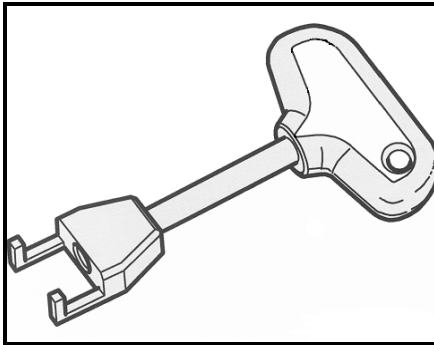

⇐ **Puller T10094** - must be used to avoid damaging ignition coils during removal

- **VAS 1978** - Wiring Harness Repair Kit

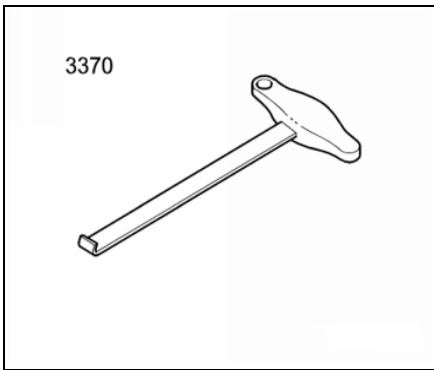

⇐ **3370 - Hook tool** (or equivalent)

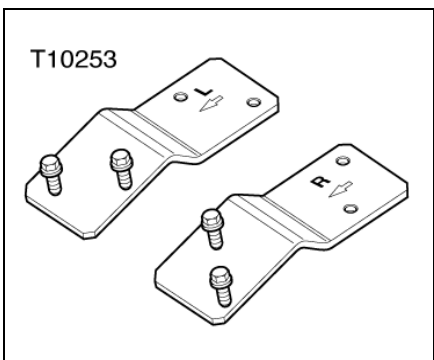

⇐ **T10253 - Latch tool with bolts**

Parts: In addition to the ignition coils, some vehicles will require additional parts. The vehicle models and respective parts are listed below:

For 2002 Jetta with automatic transmission and 2.8 liter engine:

<u>Quantity</u>	<u>Part Number</u>	<u>Part Name</u>
1	000 979 227	Repair Wire (from the VAS 1978 harness repair kit)
1	111 971 938 A	Butt Connector, (from the VAS 1978 harness repair kit)

For 2003 Jetta with automatic transmission and 2.8 liter engine:

<u>Quantity</u>	<u>Part Number</u>	<u>Part Name</u>
1	1J0 971 658 N	Harness Kit

Note: If assembled harness kit (1J0 971 658 N) is not available from parts, then the individual parts listed below can be assembled.

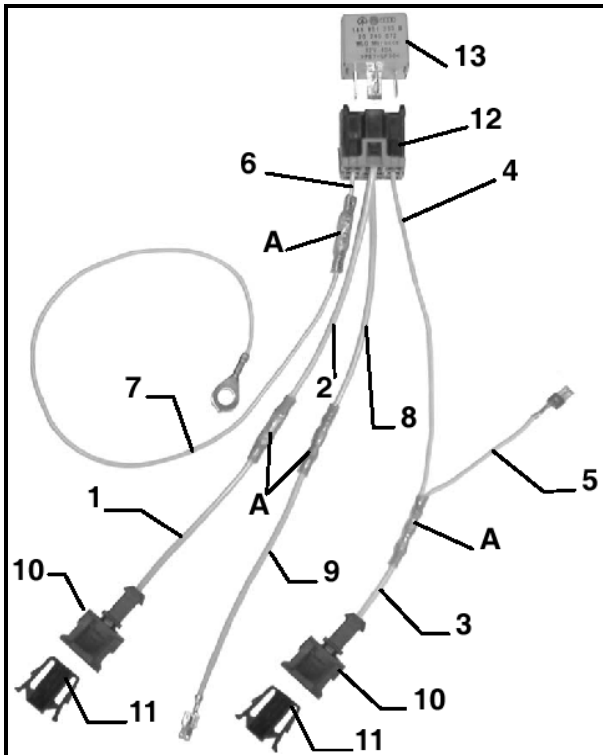

Item	Part Number	Qty.	Description
A	111 971 939 B	4	Butt Connector (Blue)*
1	000 979 220	1	Repair Wire*
2,8,9	000 979 227	2	Repair Wire*
3	000 979 130	1	Repair Wire*
4,6	000 979 114	1	Repair Wire*
5	000 979 135	1	Repair Wire*
7	000 979 137	1	Repair Wire*
10	191 972 761	2	Terminal Housing
11/11A	191 972 751	2	Terminal Housing
12	443 937 527	1	Relay Housing
13	141 951 253 B	1	Relay

- * Parts available from the VAS 1978 harness repair kit
- Relay, relay housing and terminal housings must be ordered through parts

Work Sequence:

Section A - 2.8 liter engine in Jetta and GTI vehicles

Section B - 1.8 liter engine in New Beetle, GTI, Jetta and Passat vehicles

Section C - 4.0 liter engine in Passat vehicles

Section D - 2.8 liter engine in Eurovan/Rialta vehicles

Section A – 2.8 Liter Engine in Jetta and GTI

IMPORTANT! If the vehicle has a MIL light on, the diagnostic trouble codes (DTCs) must be checked

Only cylinder misfire DTCs related to ignition coil malfunction are covered by this service action. Any other checking, diagnosis or repairs are not part of or covered under this service action

- If applicable, connect VAS5051 and check DTCs
- Open hood and remove engine cover

← Disconnect connector from all ignition coils -1-

- Using **Puller T10095**, remove ignition coils

CAUTION: USE OF TOOL T10095 IS REQUIRED TO AVOID DAMAGING THESE SENSITIVE COMPONENTS

Note: Only ignition coils that are **not** one of the production levels shown on Page 2 "*Parts Information*" must be replaced

- Install new ignition coils (022 905 100 D/G/K) by pressing into cylinder head by hand only

IMPORTANT! Do not use any object to tap ignition coil into position

Do not twist ignition coil when installing

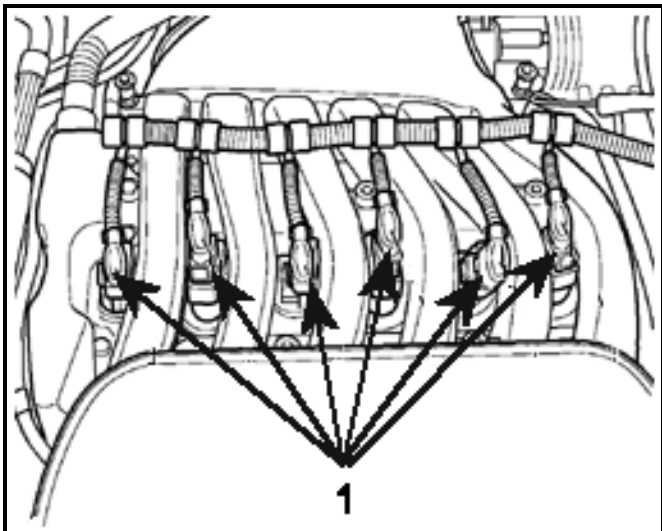

- Reconnect connectors to ignition coils
- Reinstall engine cover
- If vehicle is a 2002 model year Jetta with automatic transmission go to Section A1
- If vehicle is a 2003 model year Jetta with automatic transmission go to Section A2
- If vehicle is a Jetta or GTI with manual transmission go to Section A3

Section A1 – Wiring Harness Modification on 2002 Model Year Jetta Vehicles having a 2.8 Liter Engine with an Automatic Transmission

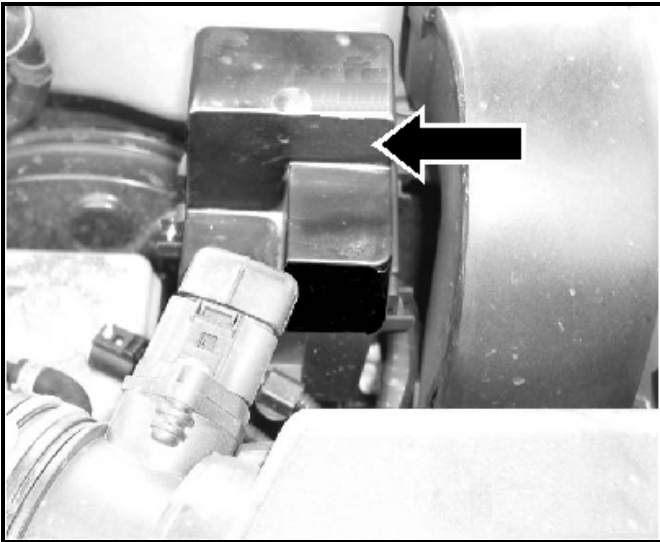

- Disconnect battery ground (GND) cable
- ⇐ Remove relay cover -arrow- for relay panel (located next to brake booster) in engine compartment

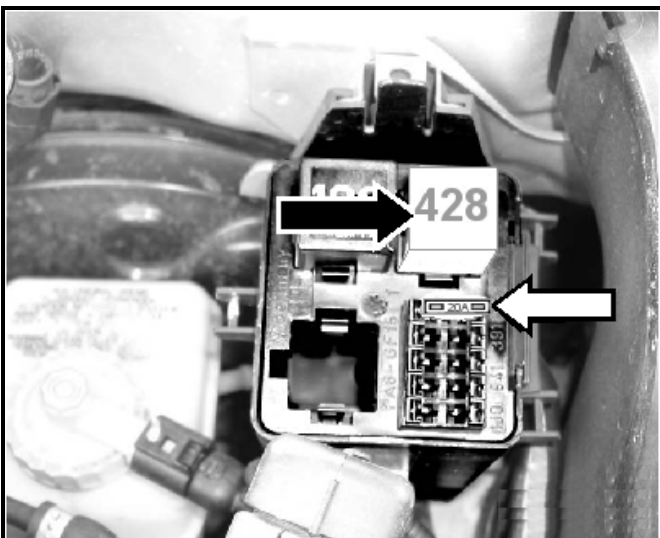

- ⇐ Remove fuse (S51) -white arrow- for vacuum pump from fuse holder
- ⇐ Remove relay #428 for the main power supply to the engine control module (ECM) -black arrow-
- Lift out relay panel from the lower housing

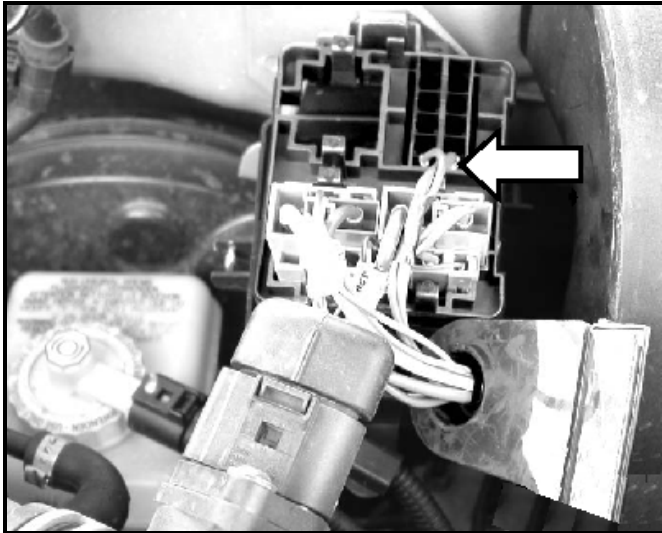

- Turn relay panel over to access wiring to fuse and relay

⇐ Remove large wire from cavity #1 for fuse (S51)
-arrow-

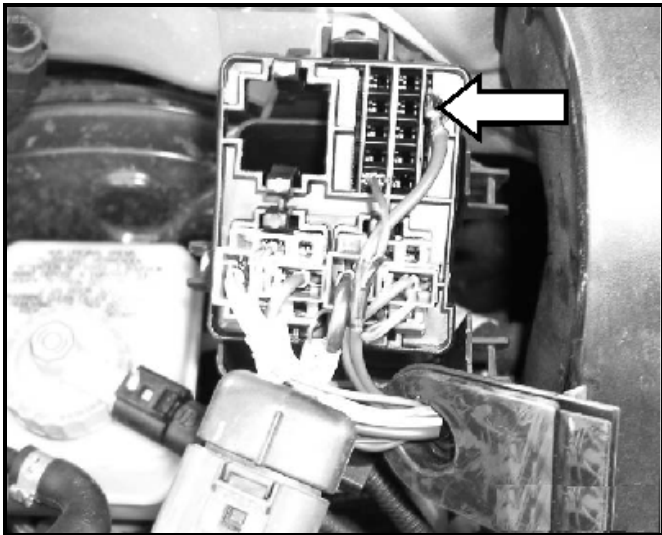

⇐ Illustration to the right shows large wire -arrow-
removed from cavity #1

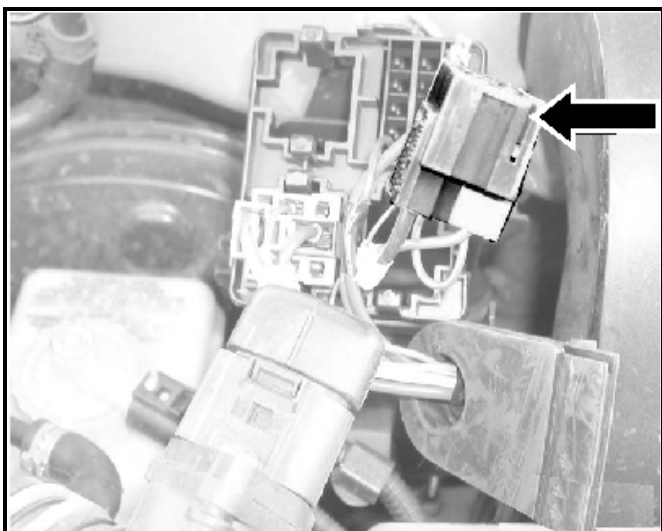

⇐ Remove red connector block (for relay #428)
-arrow- from the relay housing

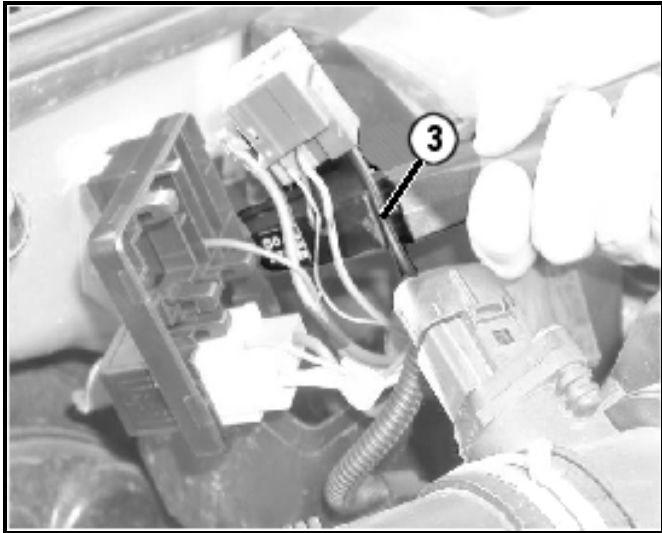

- ⇐ Locate large wire -3- from cavity 2 of the red connector for relay #428 and cut wire approximately 30 mm from terminal

Note: Cavity numbers are located on the connector at the terminal insertion points

- Strip insulation from wire ends using VAS 1978/3 wire strippers from the VAS 1978 repair kit

Note: The illustrations show the large wire installed in the relay connector housing. It may be easier to remove this terminal from the relay connector housing for the following modification

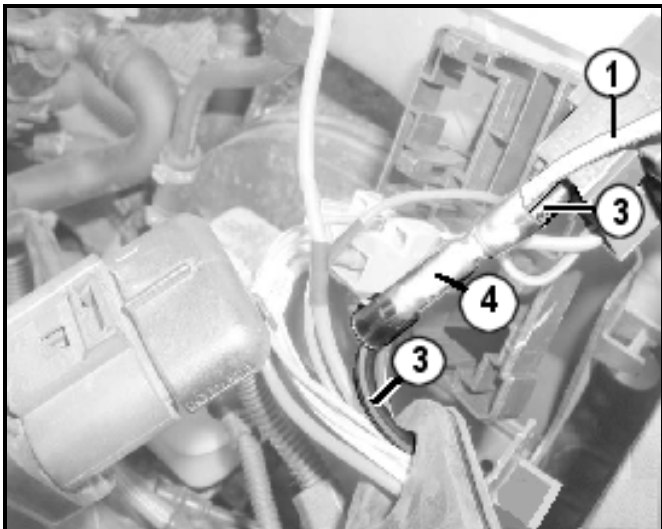

- Using new repair wire (000 979 227), cut wire approximately 100 mm from the terminal and strip the insulation from the wire (other end of the repair wire is not needed)

- ⇐ Insert the new 100 mm long repair wire -1- along with the end (30 mm length) of the previously cut wire -3- (from connector block cavity 2) into one end of a butt connector -4- (111 971 938 A)

- Crimp the butt connector using the VAS 1978/2 crimper from the VAS 1978 repair kit
- Insert remaining end of previously cut wire -3- into the other end of the butt connector -4- and crimp using the wire crimper
- Seal the butt connector using the electric hot air blower
- If the large wire was removed from the relay connector housing cavity #2 to do this modification, reinstall wire at this time

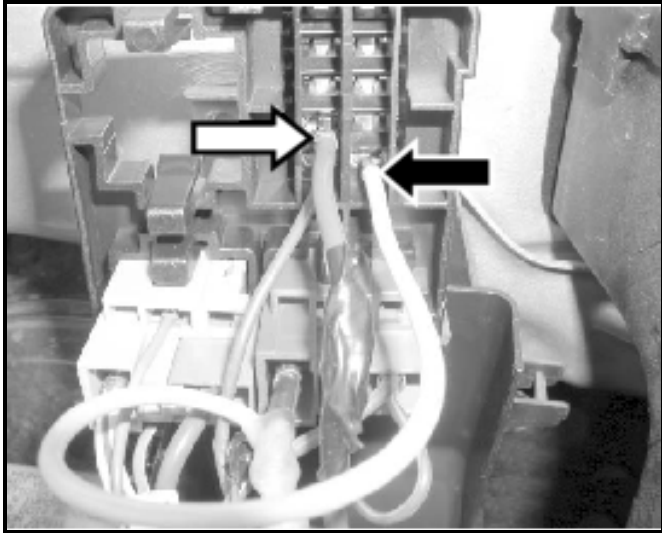

- Install the wire previously removed from the fuse holder (for fuse S51) cavity #1 into an unused cavity of the fuse holder (this wire is no longer used)

Note: In this illustration, cavity #4 was used -white arrow- however, your vehicle may be different

- ◀ Install terminal from the 100 mm repair wire into the cavity #1 -black arrow- of the fuse holder
- Reinstall red connector block for relay into relay panel
- Reinstall relay panel into lower housing
- Reinstall relay #428 and fuse (S51) into relay panel
- Reinstall relay cover
- Reconnect battery ground (GND) cable and tighten nut to 6 Nm (53 in. lbs.)
- **Proceed to Section A3**

Section A2 – Wiring Harness Modification on 2003 Model Year Jetta Vehicles Having a 2.8 Liter Engine with an Automatic Transmission

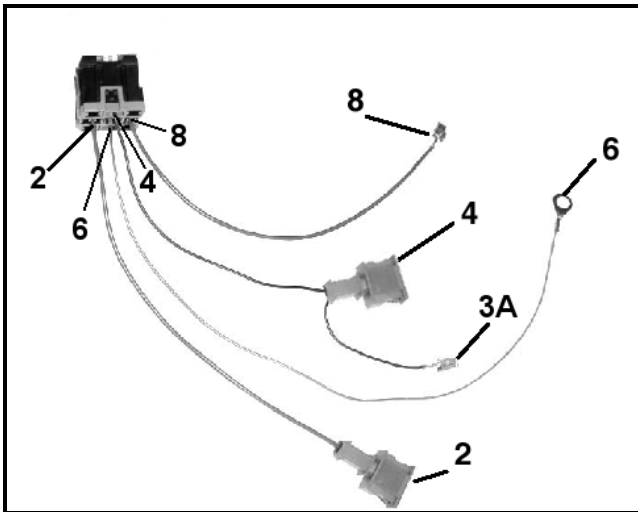

Note: Use harness kit (1J0 971 658N). If not obtainable, the harness can be assembled

Some parts are in the VAS 1978 wiring harness repair kit; other parts need to be ordered (Reference "Parts Information" on Page 2)

Instructions for harness assembly are in Section A4

IMPORTANT! The terminal ends on the wire harness from the kit or from the assembled harness are shown to correspond to the terminal connection numbers on the relay connector

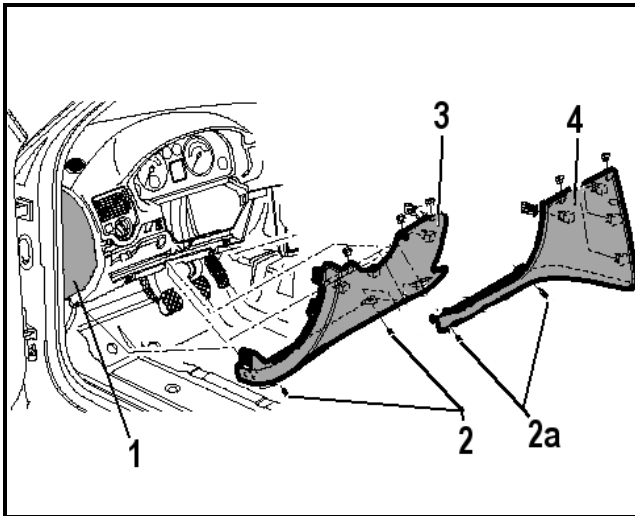

⇐ Open driver's door, remove instrument panel side cover -1-

⇐ Remove 2 screws -2- unclip trim panel -3- and remove

⇐ Remove 2 screws -2a- unclip trim panel -4- and remove

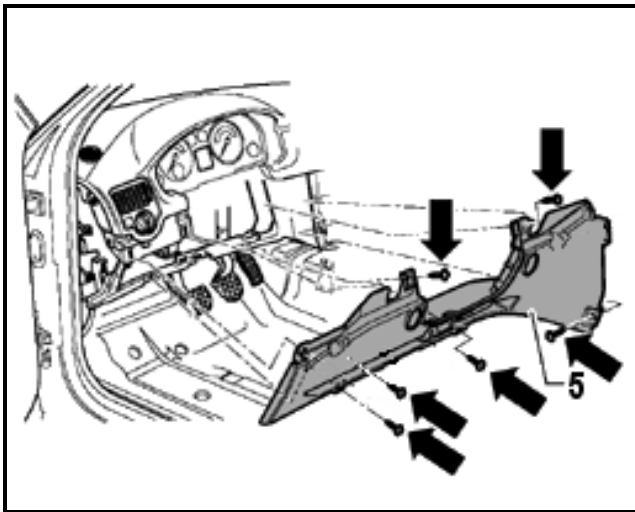

⇐ Remove (6) screws -arrows- and remove reinforcement -5-

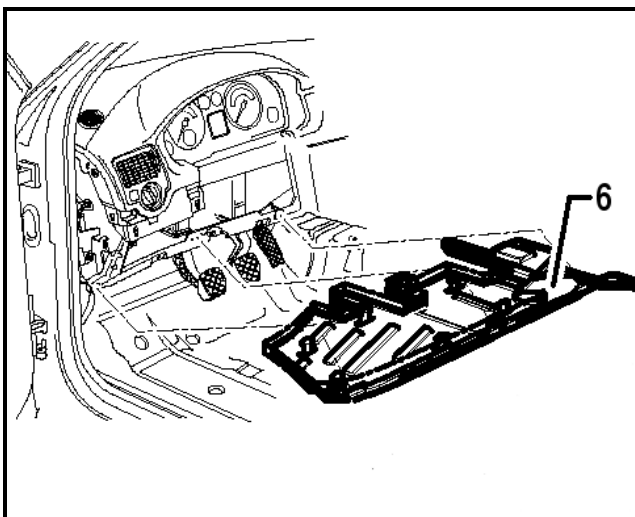

⇐ Unclip and remove lower cover -6- by sliding rearward out of clips

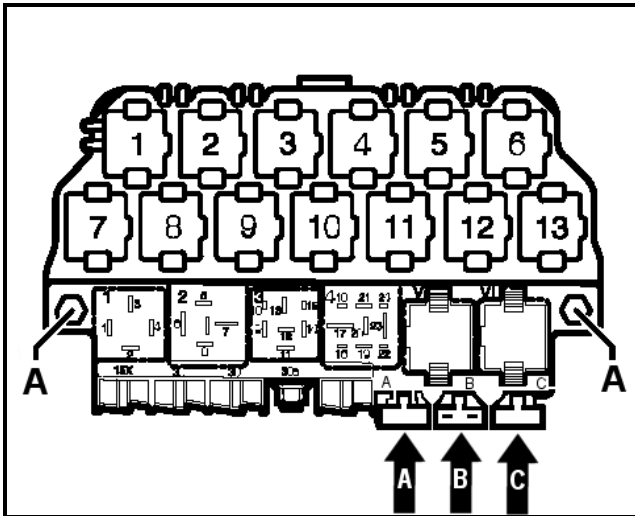

- ⇐ Using a volt meter, check the terminal contacts of the 15 amp fuse in position B -arrow- for (12 volts or B+ power) and make note of terminal position in fuse housing
- Under hood, remove battery cover and disconnect battery ground (GND) cable
- ⇐ Remove fuse/relay holders -A- and -C- (arrows) at the bottom of the lower relay panel
- ⇐ Remove fuse holder -B- from the bottom of lower relay panel -arrow- and remove fuse from holder
- ⇐ Remove (2) nuts -A- and pull lower relay carrier rearward and down to remove

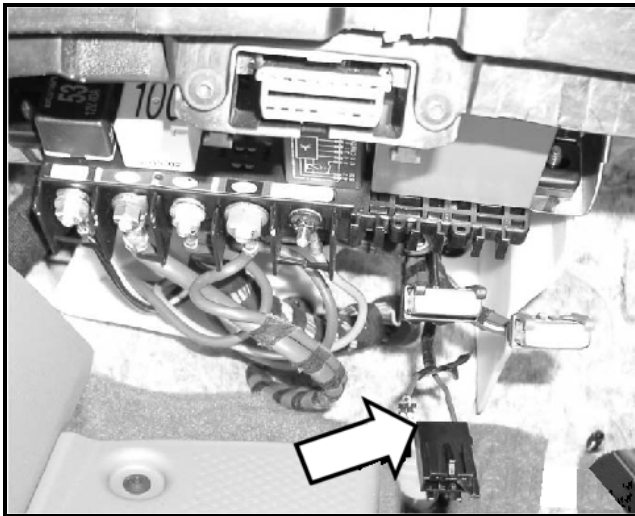

- ⇐ Remove the B+ terminal (as previously found) from fuse holder B -arrow-

Note: The illustration shows the wire removed from position #2, however, your vehicle could be different

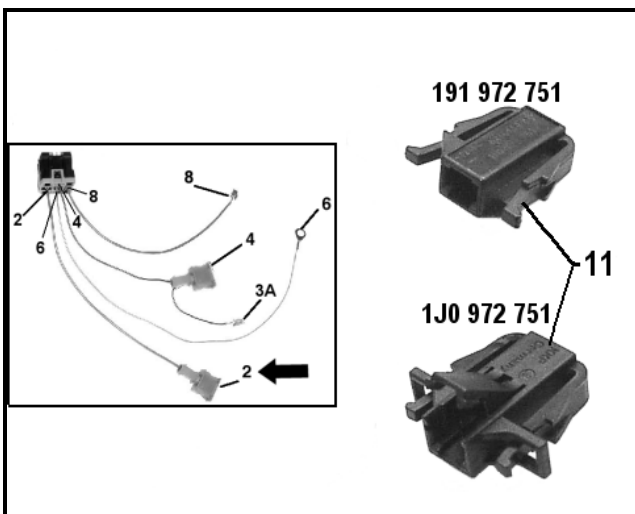

- ⇐ Insert the B+ terminal (removed from fuse holder) into terminal housing -11- (191 972 751 or 1J0 972 751)

Note: The terminal housing 1J0 972 751 comes with the wiring harness assembly.

IMPORTANT! To insert the B+ terminal into the 1J0 972 751 housing, the side clip needs to be opened

Note: This terminal housing -11- will be connected to a terminal housing -2- on the new wiring harness later in the procedure

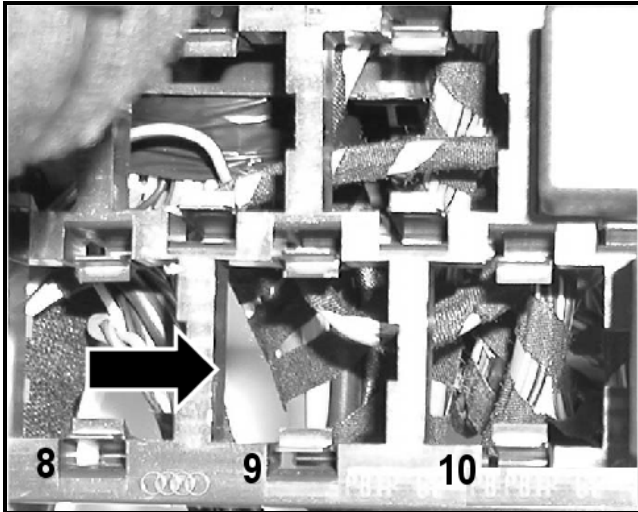

⇐ From the rear of the upper half of the relay panel, insert the new relay connector block on the new harness assembly into position #9 -arrow-

Note: The new relay must be removed from the relay connector on the new harness assembly before installing

- Route wires 2, 6 and 8 on the new harness assembly behind the fuse/relay panels

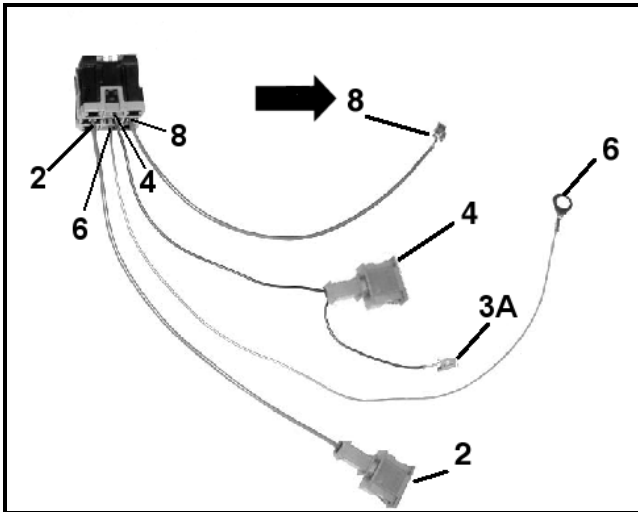

⇐ Locate terminal -8- (arrow) on the new wiring harness assembly

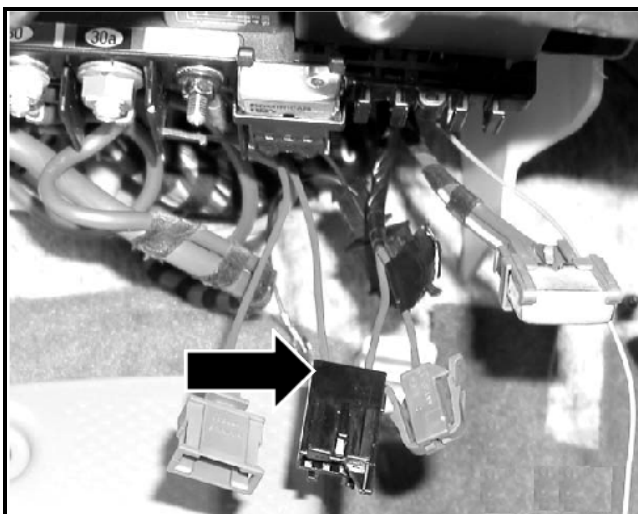

⇐ Insert terminal 8 on the new wire harness into the empty (B+) location in the 15 amp fuse holder -arrow-

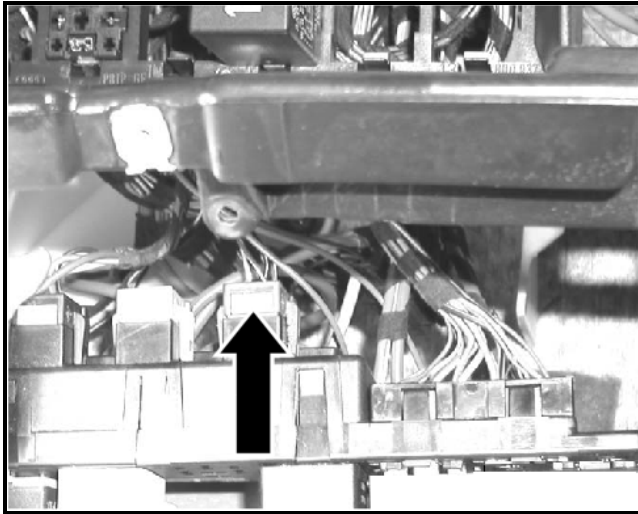

⇐ Remove (red) connector block -arrow- (for relay position 3) on reverse side of lower relay carrier

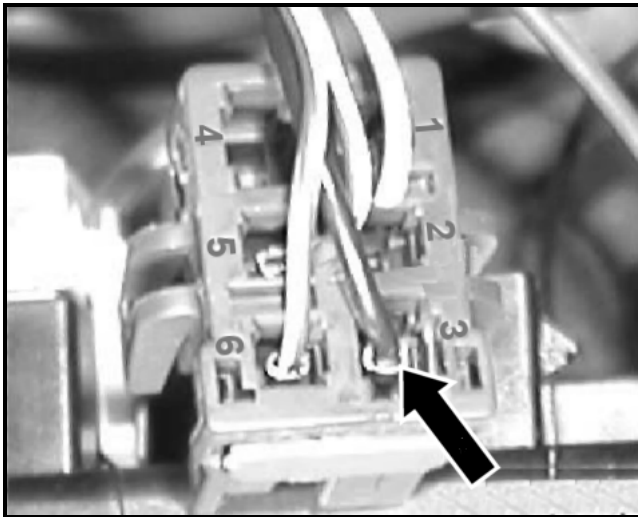

⇐ Remove terminal from position number 3 -arrow- of red connector block

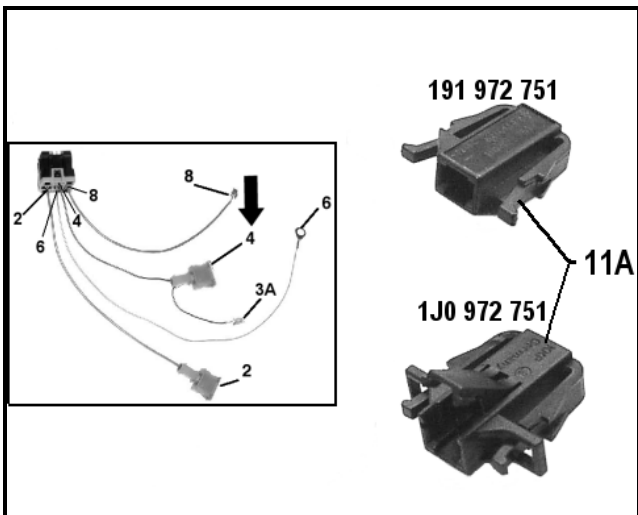

⇐ Insert this terminal -3- into connector housing -11A- (191 972 751 or 1J0 972 751)

Note: The terminal housing 1J0 972 751 comes with the wiring harness assembly.

IMPORTANT! To insert terminal -3- into the 1J0 972 751 housing, the side clip needs to be opened

⇐ Connect the housing -11A- to the connector housing -4- on the new harness assembly

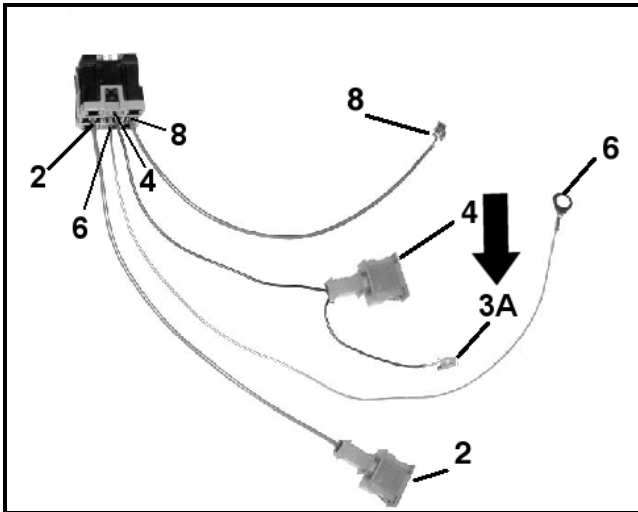

⇐ Locate terminal -3A- (arrow) [short wire from connector housing -4-] on new harness assembly

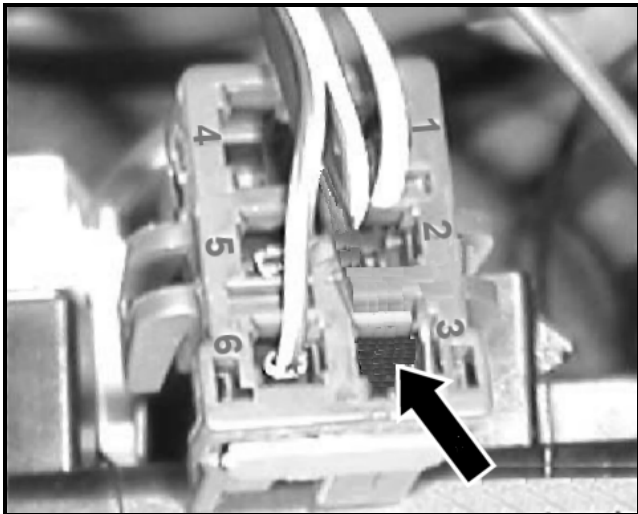

- ⇐ Insert terminal -3A- into the empty position number 3 -arrow- of red connector
- Reinstall red connector block to reverse side of relay panel (behind relay position 3)

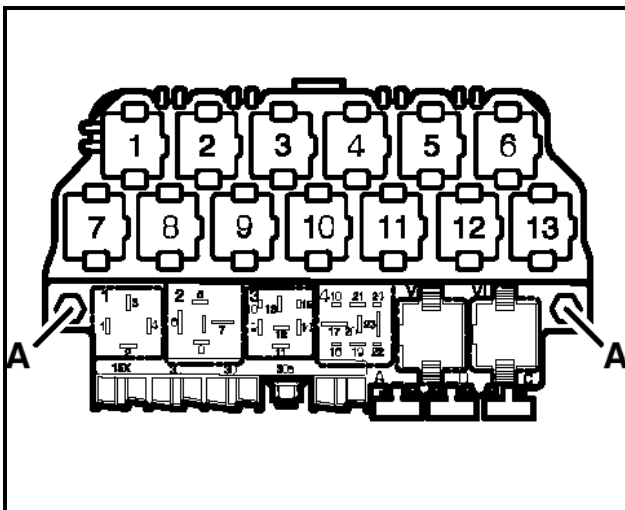

⇐ Reinstall relay carriers, secure with (2) nuts -A- and tighten to 2 Nm (18 in. lbs.)

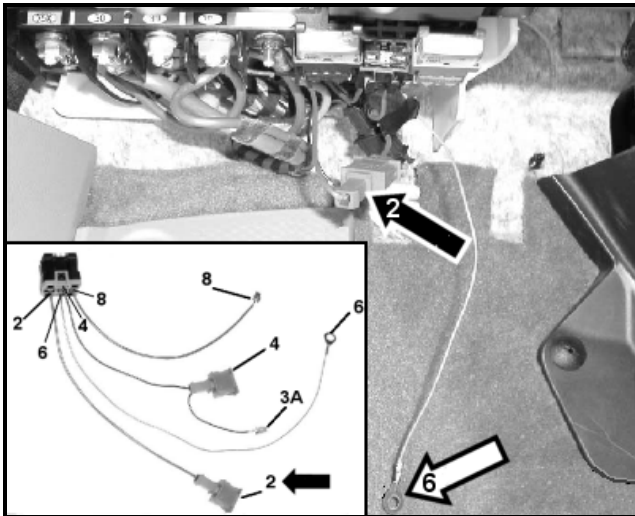

- ⇐ Insert the connector -11- (contains terminal removed from B+ fuse connector at the start of this procedure) to connector -2- (arrow) on the new wire harness assembly
- Reinstall fuse holder to location -B- on the lower relay block
- Reinstall 15 amp fuse
- Reinstall fuse/relay holders -A- & -C- into proper location on lower relay block
- ⇐ Locate ground (GND) wire -6- (eyelet terminal on the new wiring harness assembly)

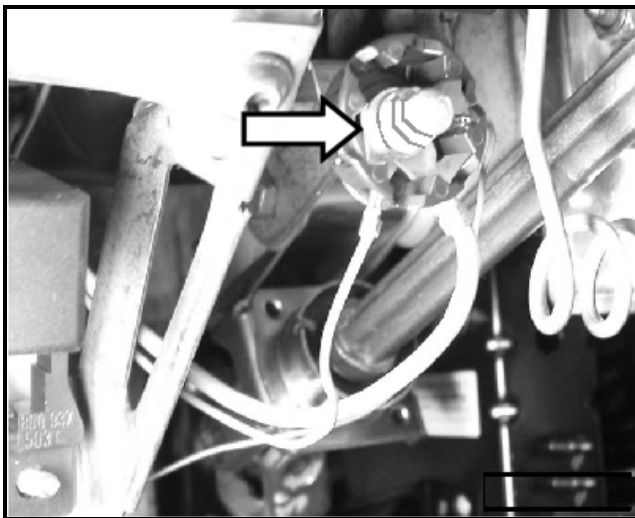

- ⇐ Remove cap nut at ground point -arrow- near steering column, install ground wire eyelet -6- from new harness assembly, secure with cap nut and tighten to 6 Nm (53 in. lbs.)

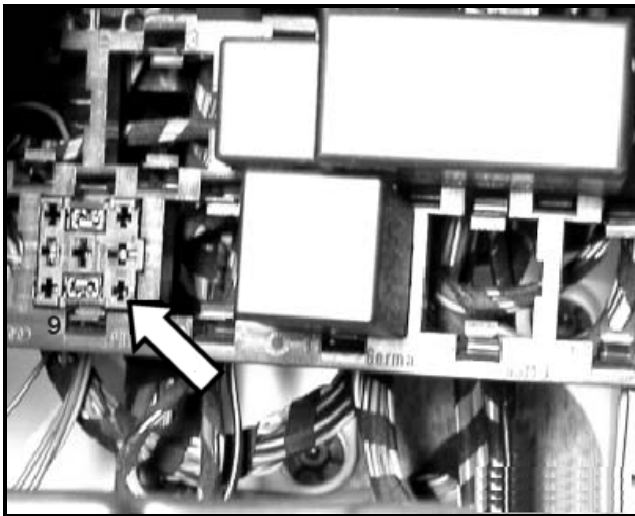

- ⇐ Install new (141 951 253 B) relay into upper relay block position 9 -arrow-
- Reinstall instrument panel lower cover
- Reinstall reinforcement and secure with (6) screws
- Reinstall lower trim panels
- Reinstall instrument panel side cover
- Reconnect battery ground (GND) cable and tighten to 6 Nm (53 in. lbs)
- Reinstall battery cover
- **Proceed to Section A3**

Section A3 - Repair verification and readiness code setting

- If a wiring harness was modified, turn ignition switch “ON” and OFF” **before** first starting engine, then:
 - Start vehicle and verify correct operation
 - Remove key and wait up to 30 seconds to ensure that the vacuum pump does not run
 - Set engine readiness code and power restoration procedure
- If a wiring harness was not modified and the MIL light was on with cylinder misfire DTCs present, printed and erased, use VAS5051 and set engine readiness code
- Attach a copy of print out for diagnostic log (showing cylinder misfire DTCs) and readiness code “Test Complete” to repair order

Note: Readiness code setting is not related to this action when other components related to the MIL light are diagnosed and repaired

- ***Destroy and properly dispose of removed ignition coils***

Section A4 – Wiring Harness Assembly

Note: This section is needed only if the wiring harness assembly 1J0 971 658 N is not obtainable

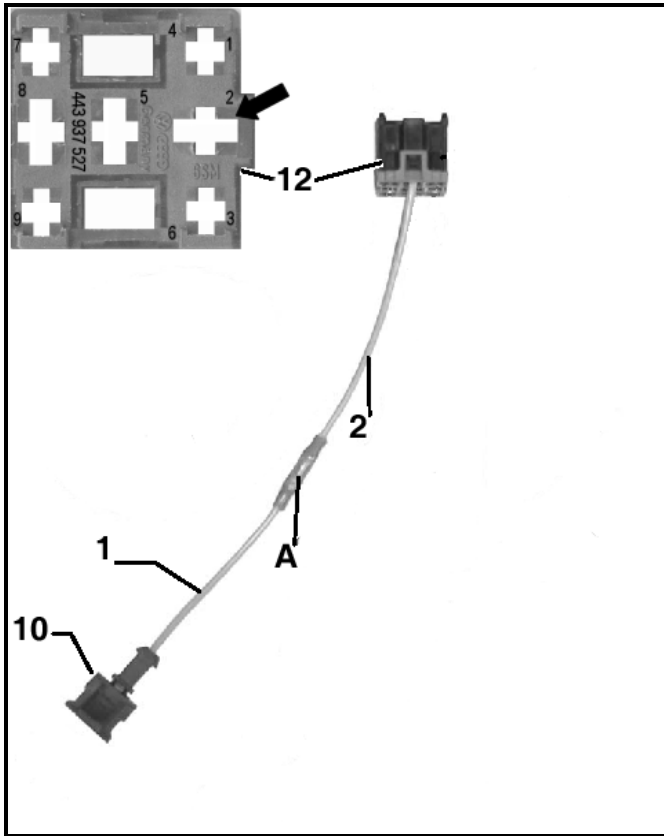

- ⇐ Using a repair wire -2- (000 979 227), cut wire approx. 100 mm from terminal, insert wire in butt connector -A- (111 971 939 B) and crimp butt connector with the VAS 1978/2 crimper
- ⇐ Using a repair wire -1- (000 979 220), cut wire approx. 100 mm from terminal, insert wire in butt connector -A- and crimp butt connector
- Seal the butt connector using the electric hot air blower from the VAS 1978 repair kit
- ⇐ Insert terminal end of wire -2- into position 2 -arrow- of relay connector -12- and wire end -1- into a terminal housing -10- (191 972 761)

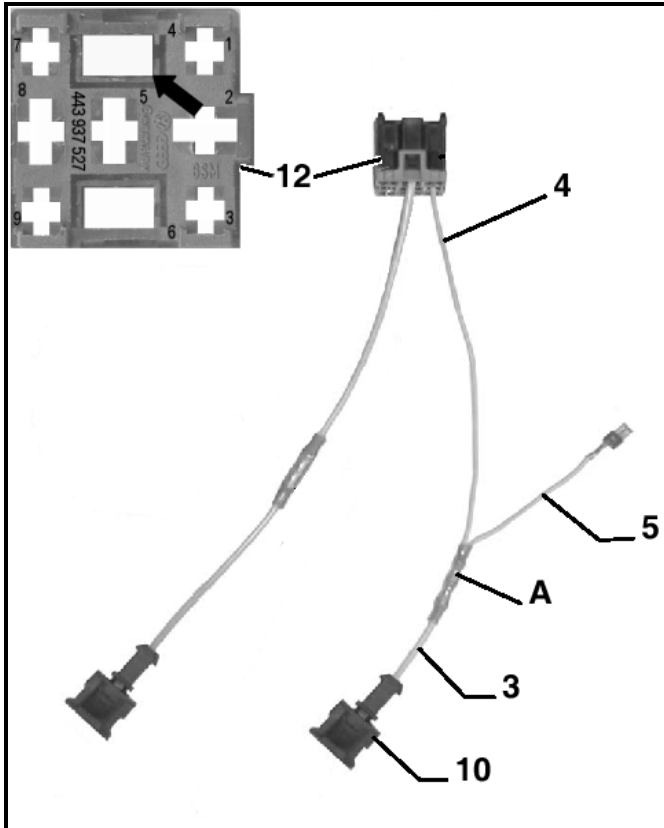

- ⇐ Using a repair wire -4- (000 979 114), cut wire approx. 150 mm from terminal
- ⇐ Using a repair wire -5- (000 979 135), cut wire approx. 80 mm from terminal
- ⇐ Insert ends of wire -4- and -5- into butt connector -A- and crimp connector
- ⇐ Using a repair wire -3- (000 979 130), cut wire approx. 70 mm from terminal, insert wire in butt connector -A- and crimp butt connector
- Seal the butt connector using the electric hot air blower
- ⇐ Insert terminal end of wire -4- into position 4 -arrow- of relay connector -12- and terminal end of wire -5- into terminal housing -10- (191 972 761)

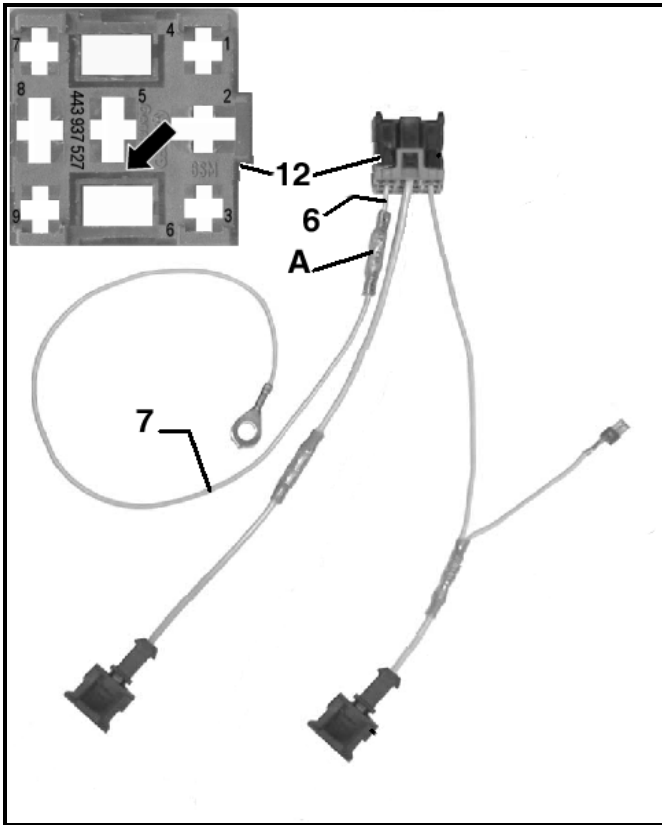

- ⇐ Using repair wire -6- (000 979 114), cut wire approx. 30 mm from terminal, insert into butt connector -A- and crimp connector
- ⇐ Using repair wire -7- (000 979 137), cut wire approx. 330 mm from eyelet, insert into butt connector -A- and crimp connector
- Seal the butt connector using the electric hot air blower
- ⇐ Insert terminal end of wire -6- into position 6 of relay connector -12-

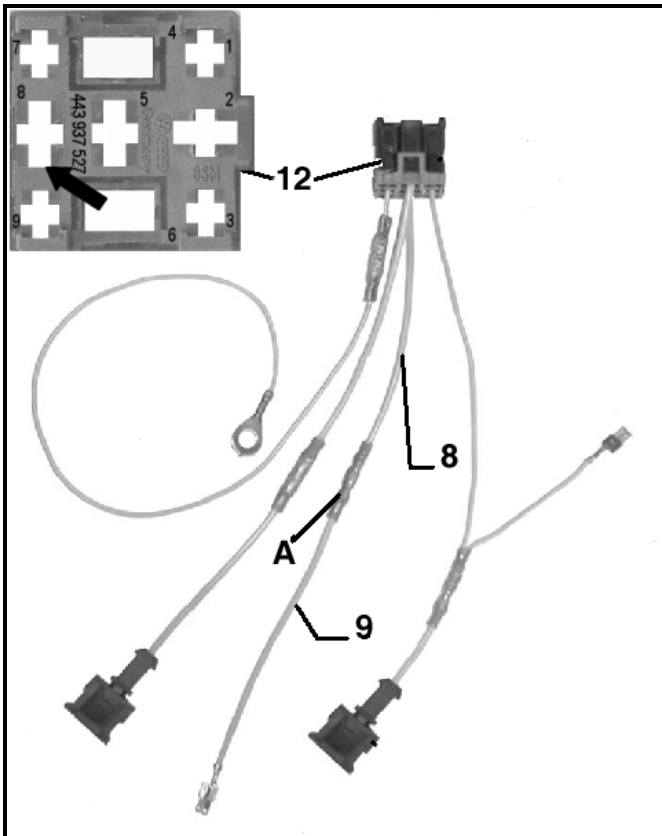

- ⇐ Using repair wire -8- (000 979 227), cut wire approx. 110 mm from eyelet, insert into butt connector -A- and crimp connector
- ⇐ Using repair wire -9- (000 979 227), cut wire approx. 110 mm from eyelet, insert into butt connector -A- and crimp connector
- Seal both ends of the butt connector using the electric hot air blower
- ⇐ Insert terminal end of wire -8- into position 8 of relay connector -12-
- **Go to Section A2 for harness installation**

Section B – 1.8 Liter Engine in New Beetle, GTI, Jetta and Passat

IMPORTANT! If the vehicle has a MIL light on, the diagnostic trouble codes (DTCs) must be checked

Only cylinder misfire DTCs related to ignition coil malfunction are covered by this service action. Any other checking, diagnosis or repairs are not part of or covered under this service action

- If applicable, connect VAS5051 and check DTCs
- Open hood and remove engine cover
- If applicable, remove screw securing vacuum reservoir located above ignition coils
- On New Beetle vehicles, remove plate with turbo boost valve and move aside

Note: Vacuum lines to reservoir and turbo boost valve do not have to be disconnected

⇐ Disconnect connectors -1- from all ignition coils -2-

Note: Only ignition coils that are **not** one of the production levels shown on Page 2 “Parts Information” must be replaced

- Using **Puller T40039**, remove ignition coils

CAUTION: Use of tool T40039 is required to avoid damaging these sensitive components

- Install new ignition coils (06B 905 115J/L) by pressing into cylinder head with hand only

IMPORTANT! Do not use any object to tap ignition coil into position

Do not twist ignition coil when installing

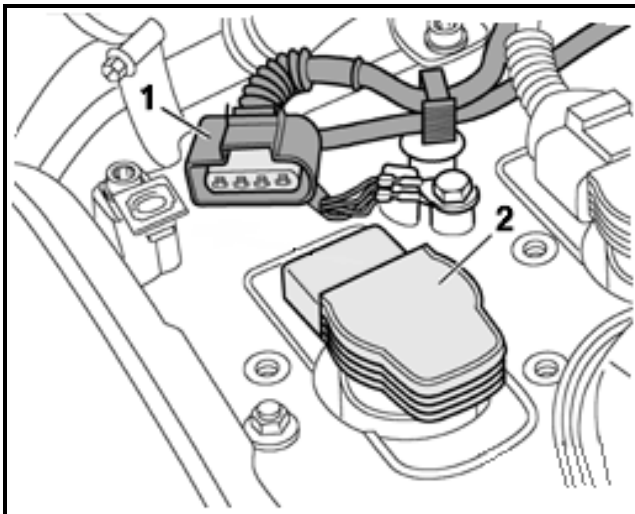

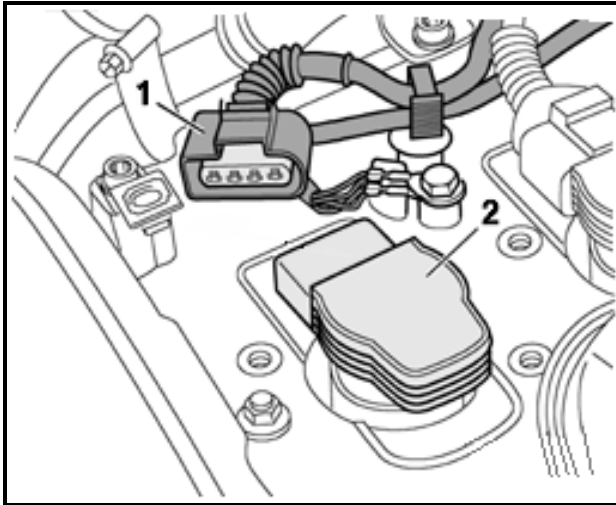

- Reconnect connectors to ignition coils
- If applicable, reinstall plate with turbo boost valve
- Reinstall vacuum reservoir and secure with bolt
- Reinstall engine cover and close hood
- If the MIL light was on and cylinder misfire DTCs were present, printed and erased, use VAS5051 and set engine readiness code
- Attach a copy of print out for diagnostic log (showing cylinder misfire DTCs) and readiness code "Test Complete" to repair order

Note: Readiness code setting is not related to this action when other components related to the MIL light are diagnosed and repaired

- ***Destroy and properly dispose of removed ignition coils***

Section C – 4.0 Liter Engine in Passat

IMPORTANT! If the vehicle has a MIL light on, the diagnostic trouble codes (DTCs) must be checked

Only cylinder misfire DTCs related to ignition coil malfunction are covered by this service action. Any other checking, diagnosis or repairs are not part of or covered under this service action

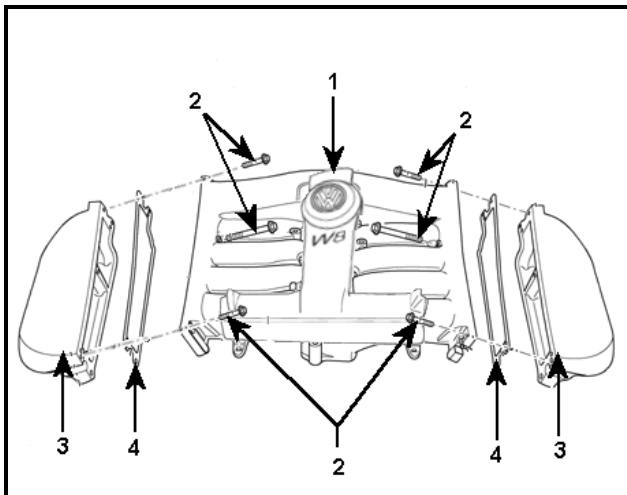

- If applicable, connect VAS5051 and check DTCs
- ⇐ Open hood and remove center manifold cover -1-
- ⇐ Remove bolts -2- securing left and right intake manifold side parts -3- and remove side part with gaskets -4-
- Disconnect connectors on all ignition coils

Note: Only ignition coils that are **not** one of the production levels shown on Page 2 "Parts Information" must be replaced

- Using **Puller T10094**, remove ignition coils on left and right banks of engine

CAUTION: USE OF TOOL T10094 IS REQUIRED TO AVOID DAMAGING THESE SENSITIVE COMPONENTS

- Install new ignition coils (07C 905 115C/D) by pressing into cylinder head by hand only

IMPORTANT! Do not use any object to tap ignition coil into position

Do not twist ignition coil when installing

- Reconnect connectors to ignition coils
- Reinstall left and right intake manifold side parts with gasket and tighten bolts to 8 Nm. (71 in. lbs.)
- Reinstall center cover and close hood
- If the MIL light was on and cylinder misfire DTCs were present, printed and erased, use VAS5051 and set engine readiness code
- Attach a copy of print out for diagnostic log (showing cylinder misfire DTCs) and readiness code "Test Complete" to repair order

Note: Readiness code setting is not related to this action when other components related to the MIL light are diagnosed and repaired

- ***Destroy and properly dispose of removed ignition coils***

Section D – 2.8 Liter Engine in Eurovan/Rialta

IMPORTANT! If the vehicle has a MIL light on, the diagnostic trouble codes (DTCs) must be checked

Only cylinder misfire DTCs related to ignition coil malfunction are covered by this service action. Any other checking, diagnosis or repairs are not part of or covered under this service action

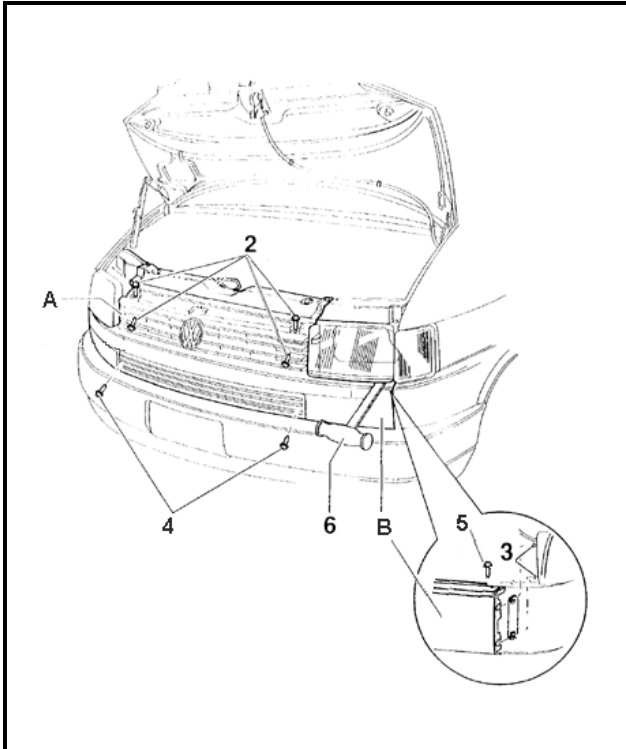

- If applicable, connect VAS5051 and check DTCs
- Open hood and remove T30 torx® screws securing engine cover and remove engine cover

⇐ Remove screws -2- and remove radiator grille -A-

- Remove left and right turn signal lights

⇐ Remove screws -4- and -5-

⇐ Use special hook tool 3370 -6- and pull trim panel -B- off guide tabs -3- on left and right sides

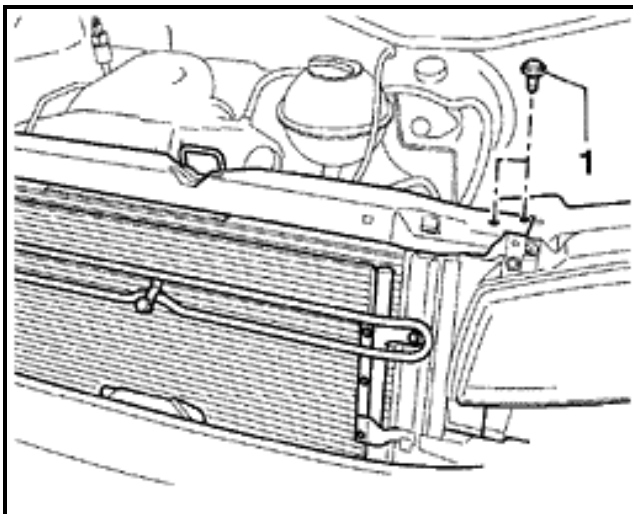

⇐ Remove lock carrier bolts -1- on left and right sides

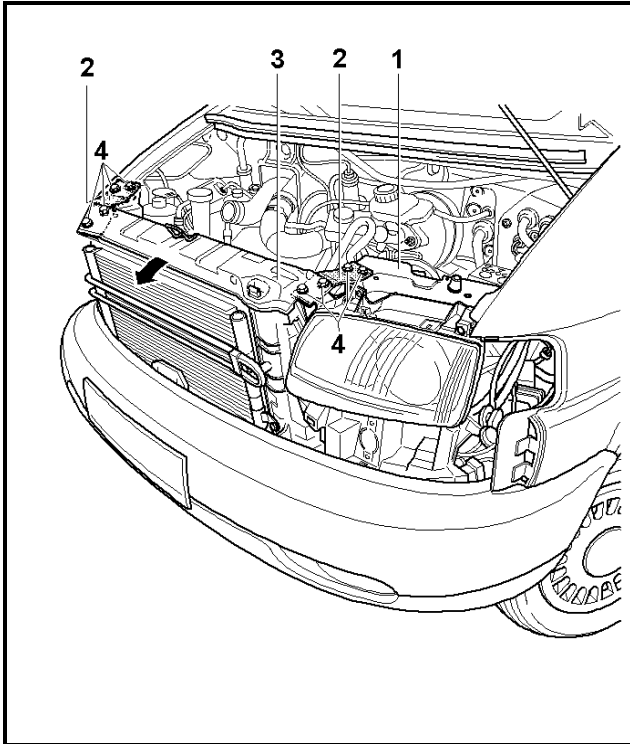

- ⇐ Pivot the lock carrier -3- with radiator in the forward direction -arrow-
- ⇐ Attach latch tool T10253 -2- between lock carrier -3- and mounting panel for headlight -1- on both left and right sides using bolts -4-

Note: Each holding tool is marked "R" for right side or "L" for left side

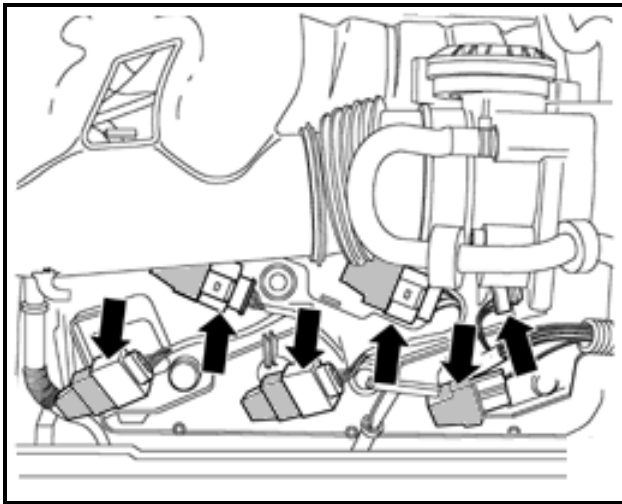

- ⇐ Disconnect connectors -arrows- from all ignition coils

Note: Only ignition coils that are **UU**not one of the production levels shown on Page 2 "Parts Information" must be replaced

- ⇐ Using **Puller T10095**, remove ignition coils

CAUTION: USE OF TOOL T10095 IS REQUIRED TO AVOID DAMAGING THESE SENSITIVE COMPONENTS

- Install new ignition coils (022 905 100C/F/J) by pressing into cylinder head by hand only

IMPORTANT! Do not use any object to tap ignition coil into position

Do not twist ignition coil when installing

- Reconnect connectors to ignition coils

- Remove latch tool T10253
- Pivot the lock carrier with radiator back into position
- Secure lock carrier with bolts -1- on left and right sides and tighten to 10 Nm (7 ft. lbs.)
- Reinstall engine cover and secure with T30 Torx® screws
- If the MIL light was on and cylinder misfire DTCs were present, printed and erased, use VAS5051 and set engine readiness code
- Attach a copy of print out for diagnostic log (showing cylinder misfire DTCs) and readiness code "Test Complete" to repair order

Note: Readiness code setting is not related to this action when other components related to the MIL light are diagnosed and repaired

- ***Destroy and properly dispose of removed ignition coils***

Time Requirements/Reimbursement

To ensure prompt reimbursement, be sure to enter, immediately replacement of the ignition coils the applicable reimbursement code listed below.

WG Data Entry Procedure

Claim Type	Repair Code (Damage Code Field)	Time UUUUUUUnits	Work Scope
RC	WG12	50 T.U.	<p><u>2.8L Jetta & GTI Vehicles</u></p> <ul style="list-style-type: none"> - Replace ignition coils 6 022 905 100D/G/K Ignition coil
RC	WG13	110 T.U.	<p><u>2.8L Jetta & GTI Vehicles</u></p> <ul style="list-style-type: none"> - Replace ignition coils - Fault Diagnosis and Set Readiness Code 6 022 905 100D/G/K Ignition coil
RC	WG14	40 T.U.	<p><u>1.8T New Beetle, Jetta, GTI & Passat Vehicles</u></p> <ul style="list-style-type: none"> - Replace ignition coils 4 06B 905 115J/L Ignition coil
RC	WG15	100 T.U.	<p><u>1.8T New Beetle, Jetta, GTI & Passat Vehicles</u></p> <ul style="list-style-type: none"> - Replace ignition coils - Fault Diagnosis and Set Readiness Code 4 06B 905 115J/L Ignition coil
RC	WG16	110 T.U.	<p><u>4.0L Passat W8 Vehicles</u></p> <ul style="list-style-type: none"> - Replace ignition coils 8 07C 905 115C/D Ignition coil
RC	WG17	170 T.U.	<p><u>4.0L Passat W8 Vehicles</u></p> <ul style="list-style-type: none"> - Replace ignition coils - Fault Diagnosis and Set Readiness Code 8 07C 905 115C/D Ignition coil
RC	WG18	50 T.U.	<p><u>2.8L EuroVan/Rialta V6 Vehicles</u></p> <ul style="list-style-type: none"> - Replace ignition coils 6 022 905 100C/F/J Ignition coil
RC	WG19	110 T.U.	<p><u>2.8L EuroVan/Rialta V6 Vehicles</u></p> <ul style="list-style-type: none"> - Replace ignition coils - Fault Diagnosis and Set Readiness Code 6 022 905 100C/F/J Ignition coil
There is NO reimbursement for vehicle wash or loaner.			

The system automatically enters the part number and labor applicable to the above listed codes.

SUBLETS At-A-Glance

	<u>SUB LBR</u>	<u>SUB PTS</u>
P/N 000 979 227 Wire (from the VAS 1978 harness repair kit)		\$ 2.31, if applicable
P/N 111 971 938 A Butt Connector (from the VAS 1978 harness repair kit)		\$ 3.19, if applicable
110 TU for labor on 2002 Jetta automatic wiring harness modification	Add 110 TU at dealer's established labor rate, if applicable	
130 TU for labor on 2003 Jetta automatic to install new wiring harness assembly	Add 130 TU at dealer's established labor rate, if applicable	
165 TU for labor on 2003 Jetta automatic to assemble and install new wiring harness assembly	Add 165 TU at dealer's established labor rate, if applicable	

TO BE PROPERLY REIMBURSED, IT IS IMPERATIVE THAT A SUBLET AMOUNT IS CLAIMED IN THE PROPER SUBLET FIELD AS IDENTIFIED and THAT SUBLET EXPENSE COPIES REMAIN ATTACHED TO YOUR COPY OF THE REPAIR ORDER.

Please note that in some instances vehicles repaired prior to this action already have improved coils (reference "Parts Information" on Page 2) and do not require replacement.

The above reimbursement codes assume all coils were replaced on respective vehicles.
Adjustments will be made on claims where improved coil replacement occurred prior to initiation of the WG Service Action.

For vehicles that, according to your information, cannot be corrected, and one of the codes below best describe the reason, please enter into the system one of the codes indicated, as applicable:

WG 20	Customer Refused Repairs
WG 30	Total Loss
WG 40	Vehicle Stolen
WG 50	Vehicle Exported

California Emission Recall Requirements – For California Dealers ONLY

The California Air Resources Board and the Department of Motor Vehicles (DMV) require that emissions-related recalls be completed prior to vehicle registration renewal. **It is, therefore, imperative that upon completion of this recall work that you provide the owner with a signed "Vehicle Emission Recall – Proof of Correction" Certificate.** This certificate, #RC0801 CALEM ALL, will accompany the California owner notification letters. The California Department of Motor Vehicles requires that the size and color of the certificate is identical to the sample provided in this package. Therefore, *if you need additional certificates please order them through Dyment using the above-mentioned order number.*

Service Action Verification

For verification, **always** check the OTIS View Campaign inquiry screen. The OTIS system is the **only** binding campaign inquiry and verification system; other systems *are not valid and may result in non-payment of a claim*.

Service Help

If you have questions regarding this or any other recall or service action, please call (800) 741-2919.

Dealer Personnel Information

Please inform and/or provide a copy of this important communication to every person in your dealership who has campaign-related responsibilities, including parts and accounting personnel.

Thank you for your cooperation.



Maria Cotter
Product Compliance



California Regulations

Dear Mr. Sample,

We are now accelerating the process of replacing all ignition coils in cars potentially affected, whether a malfunction has occurred or not. We are writing to you today to invite you to return to your Volkswagen dealer to have your vehicle updated.

If an ignition coil becomes inoperative, the engine and its electronic controls are designed to keep your vehicle running. Your Malfunction Indicator Lamp (MIL) will illuminate and you may experience some deterioration in performance. This condition may also affect the emissions of your vehicle. You can continue driving and should take your car to the nearest Volkswagen dealer for repair.

The update to your vehicle will take less than one hour. Please call the service department of your Volkswagen dealer to schedule an appointment.

*California regulations require that this repair be completed prior to the time that you renew your vehicle registration. **Please make sure that this repair is completed prior to the renewal of your vehicle registration** and that you furnish proof of repair to the DMV in the form of a copy of the dealer's repair order including a signed "Emission Campaign Performance Authorization" which is enclosed with this letter. Please retain the signed certification form with your vehicle records. DO NOT MAIL THIS FORM to the Department of Motor Vehicles (DMV) unless requested.*

If you are the lessor and registered owner of the vehicle identified in this action, please forward this information immediately by first class mail to the lessee.

If you have already incurred out-of-pocket expenses, please write us at the address below, and we'll be happy to reimburse you. Please include any receipts you might have along with your letter.

Volkswagen of America, Inc.
Attn: Customer Relations
3499 Hamlin Road
Rochester Hills, MI 48309

I want to emphasize that taking care of you, our customer, remains our highest priority and we thank you for your patience. If you have any further questions, or require assistance locating a Volkswagen dealer, please visit vw.com or call us directly at (800) 822-8987.

Thank you for your continued loyalty.

Sincerely,

Frank Maguire
Vice President



49 States

Dear Mr. Sample,

We are now accelerating the process of replacing all ignition coils in cars potentially affected, whether a malfunction has occurred or not. We are writing to you today to invite you to return to your Volkswagen dealer to have your vehicle updated.

If an ignition coil becomes inoperative, the engine and its electronic controls are designed to keep your vehicle running. Your Malfunction Indicator Lamp (MIL) will illuminate and you may experience some deterioration in performance. This condition may also affect the emissions of your vehicle. You can continue driving and should take your car to the nearest Volkswagen dealer for repair.

The update to your vehicle will take less than one hour. Please call the service department of your Volkswagen dealer to schedule an appointment.

If you are the lessor **and registered owner of the vehicle identified in this action, please forward this information immediately by first class mail to the lessee.**

If you have already incurred out-of-pocket expenses, please write us at the address below, and we'll be happy to reimburse you. Please include any receipts you might have along with your letter.

Volkswagen of America, Inc.
Attn: Customer Relations
3499 Hamlin Road
Rochester Hills, MI 48309

I want to emphasize that taking care of you, our customer, remains our highest priority and we thank you for your patience. If you have any further questions, or require assistance locating a Volkswagen dealer, please visit vw.com or call us directly at (800) 822-8987.

Thank you for your continued loyalty.

Sincerely,

Frank Maguire
Vice President