

Document ID: 3285402

## #11175A: Special Coverage Adjustment -Shift Lever May Not Display Correct Gear - (Feb 11, 2013)

Subject: 11175A – Special Coverage Adjustment — Shift Lever May Not Display Correct Gear



Models: 2007-2008 Saturn AURA

Equipped with 4-Speed Automatic Transmission (ME7/MN5)

The service procedure in this bulletin has been revised to include the installation of a cable kit (clam shell). Please discard all copies of bulletin 11175.

### Condition

Some 2007-2008 model year Saturn AURA vehicles equipped with a 4-speed automatic transmission (ME7/MN5) have a condition in which the transmission shift cable may fracture. As the fracture begins, the driver may have a difficult time selecting a gear or removing the key from the ignition. If these warnings are ignored, the cable could continue to fracture and shift function could be lost. The driver may not be able to restart the vehicle or shift the vehicle into PARK, allowing the vehicle to roll away if the driver has exited the vehicle without applying the park brake.

### Special Coverage Adjustment

This special coverage covers the condition described above for a period of 10 years or 120,000 miles (193,000 km), whichever occurs first, from the date the vehicle was originally placed in service, regardless of ownership.

Dealers are to replace the transmission shift cable. The repairs will be made at no charge to the customer.

For vehicles covered by Vehicle Service Contracts, all eligible claims with repair orders on or after November 22, 2011, are covered by this special coverage and must be submitted using the labor operation codes provided with this bulletin. Claims with repair orders prior to November 22, 2011, must be submitted to the Service Contract provider.

### Vehicles Involved

Involved are *certain* 2007-2008 model year Saturn AURA vehicles equipped with a 4-speed automatic transmission (ME7/MN5).

**Important: Dealers are to confirm vehicle eligibility prior to beginning repairs by using the Applicable Warranties section in the Global Warranty Management system.**

### Part Information

© 2013 General Motors. All rights reserved.

Parts required to complete this special coverage are to be obtained from General Motors Customer Care and Aftersales (GMCC&A).

<i>Part Number</i>	<i>Description</i>	<i>Quantity/Vehicle</i>
25907374	Bracket, A/Trns Range Sel Lvr Cbl	1
25907379	Cable, A/Trns Range Sel Lvr	1
19210732	Cable Kit, A/Trns Range Sel Lvr	1

## Service Procedure

1. Verify that the transmission shift cable requires replacement. Refer to the appropriate diagnostic information in SI. Pay particular attention for any signs of fraying or fracture.
  - If the transmission shift cable does NOT require replacement, no further action is required. Inform the customer that any additional diagnosis and repairs are not covered under this special coverage.
  - If the transmission shift cable requires replacement, proceed to Step 2.
2. Remove the floor shift control cable. Refer to *Floor Shift Control Cable Replacement* in SI.

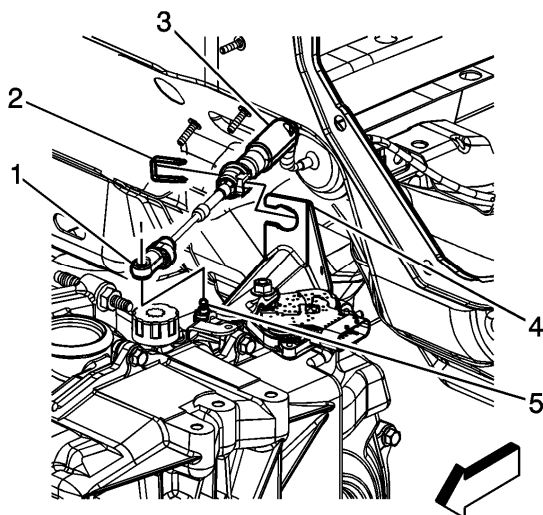



3. Remove and discard the cable bracket (4).
4. Install a new floor shift control cable and new bracket. Refer to *Floor Shift Control Cable Replacement* in SI.

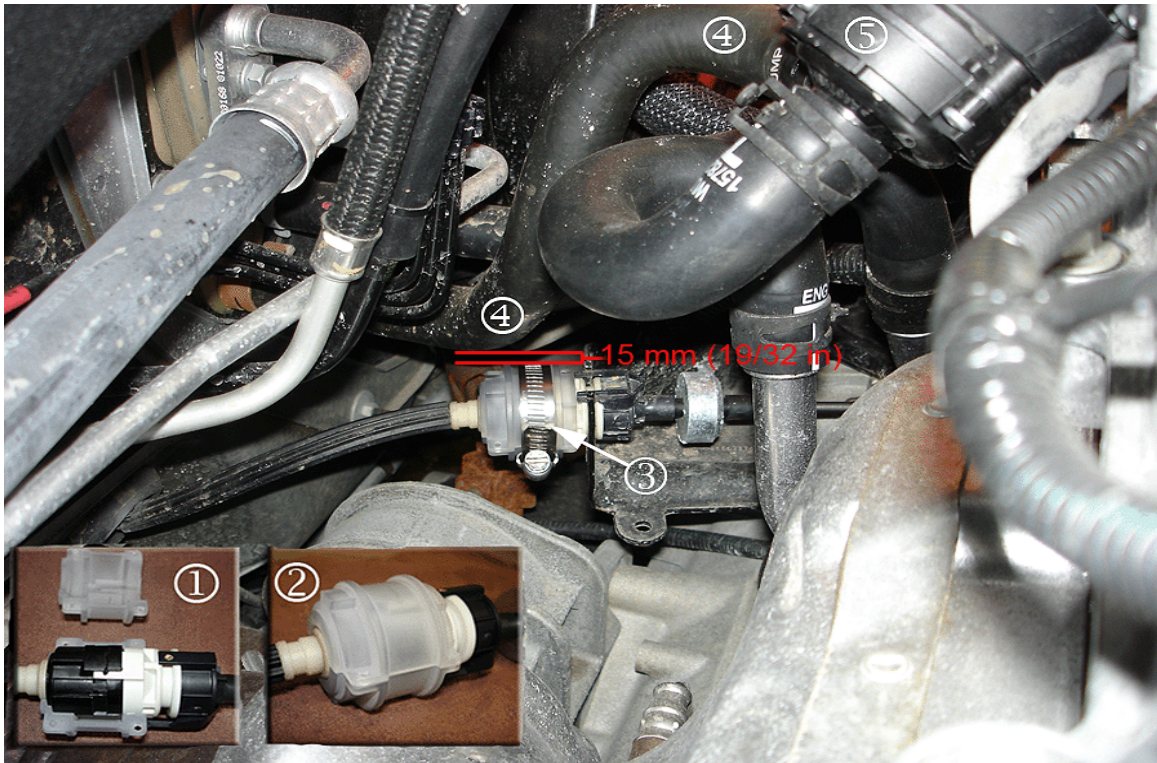

Note: Hybrid vehicle shown. Combustion engine vehicle is similar.

1 – Clam Shell in Two Pieces

2 – Clam Shell Around Shift Cable Locking Tabs

3 – Clamp on Clam Shell

4 – Inlet Coolant Hose and

5 – Heater Cooler Pump.

5. Install the clam shell (1) (2) over the shifter cable locking tabs.
6. Install the service clamp over the clam shell (3). Position the clamp fastener head away from the inlet coolant hose (4). *Tighten the clamp to 4 N·m (35 lb-in).*
7. Ensure that there is 15 mm (19/32 in) of clearance between the inlet coolant hose (4) and the clam shell (3). On hybrid equipped vehicles, it may be necessary to reposition the inlet coolant hose (4) to achieve the required 15 mm (19/32 in) of clearance. *To reposition the inlet coolant hose (4) on hybrid equipped vehicles, locate the heater cooler pump (5) and perform Steps 5.1-5.4.*

Caution Do not kink or damage the inlet coolant hose (4) when repositioning the hose to obtain the 15 mm (19/32 in) clearance. To avoid damaging the hose clamp, use J-38185 or equivalent hose clamp pliers to loosen the hose clamp.

- 7.1 Using J-38185 or equivalent hose clamp pliers, loosen the inlet coolant hose (4) connected to the heater cooler pump (5). Note the location of the clamp on the inlet coolant hose (4).

Caution Do not kink or damage the inlet coolant hose (4) when repositioning the hose to obtain the 15 mm (19/32 in) clearance. To avoid damaging the hose clamp, use J-38185 or equivalent hose clamp pliers to loosen the hose clamp.

- 7.2 Rotate the inlet coolant hose (4) clockwise until 15 mm (19/32 in) of clearance between the inlet coolant hose (4) and clam shell (3) is achieved.

- 7.3 Ensure that the inlet coolant hose clamp is secure on the inlet coolant hose (4) in the production location.

- 7.4 Install the generator control module cover. Refer to *Generator Control Module Cover Replacement* in SI.

8. Close the hood.

## [Customer Reimbursement – For US](#)

Customer requests for reimbursement of previously paid repairs to correct the condition described in this bulletin are to be submitted to the dealer by December 31, 2012, unless otherwise specified by state law. If this is not convenient for the customer, they may mail the completed form and all required documents to the GM Customer Assistance Center. Repairs must have occurred within the 10 years of the date the vehicle was originally placed in service, or 120,000 miles, whichever occurs first.

All reasonable customer paid receipts should be considered for reimbursement. The amount to be reimbursed will be limited to the amount the repair would have cost if completed by an authorized General Motors dealer.

When a customer requests reimbursement, they must provide the following:

- A completed Customer Reimbursement Request Form. This form is mailed to the customer or can be obtained through GM GlobalConnect.
- The name and address of the person who paid for the repair.
- Paid receipt confirming the amount of the repair expense, a description of the repair, and the person or entity performing the repair.

**Important:** If a reimbursement request is denied, dealers **MUST** provide the customer with an explanation, in writing, as to why the request was denied. GM expects all reimbursement requests to be approved or denied within 30 days of receipt. If the denial was due to missing documents, the customer can resubmit when the missing documents are obtained, as long as it is still within the allowed reimbursement period.

Claims for customer reimbursement on previously paid repairs are to be submitted as required by GWM.

## Customer Reimbursement – For Canada

Customer requests for reimbursement of previously paid repairs to correct the condition described in this bulletin are to be submitted to the dealer prior to or by December 31, 2012. Repairs must have occurred within the 10 years of the date the vehicle was originally placed in service, or 193,000 kilometres, whichever occurs first.

When a customer requests reimbursement, they must provide the following:

- Proof of ownership at time of repair.
- Original paid receipt confirming the amount of unreimbursed repair expense(s) (including Service Contract deductibles), a description of the repair, and the person or entity performing the repair.

If the work was done by someone other than a GM dealership, the amount of reimbursement will be limited to the amount that the repair would have cost GM to have it completed by a GM dealership

## Courtesy Transportation

The General Motors Courtesy Transportation program is intended to minimize customer inconvenience when a vehicle requires a repair that is covered by the New Vehicle Limited Warranties. The availability of courtesy transportation to customers whose vehicles are within the warranty coverage period and involved in a product program is very important in maintaining customer satisfaction. Dealers are to ensure that these customers understand that shuttle service or some other form of courtesy transportation is available and will be provided at no charge. Dealers should refer to the General Motors Service Policies and Procedures Manual for Courtesy Transportation guidelines.

## Warranty Transaction Information

Submit a transaction using the table below.

<i>Labor Code</i>	<i>Description</i>	<i>Labor Time</i>	<i>Net Item</i>
T5842	Diagnostic Time Only – No Repair Required	0.1-0.3	N/A
T5843	Replace Transmission Shift Cable (inc. install transmission shift cable kit)	1.1	N/A
	Add: Hybrid Vehicle	0.1	

	Add: Diagnostic Time	0.1-0.3	
T5844	Customer Reimbursement Approved	0.2	*
T5845	Customer Reimbursement Denied - For US dealers only	0.1	N/A

\* The amount identified in "Net Item" should represent the dollar amount reimbursed to the customer.

### Customer Notification

General Motors will notify customers of this special coverage on their vehicles (see copy of typical customer letter included with this bulletin - actual divisional letter may vary slightly).

November 2011

Dear General Motors Customer:

As the owner of a 2007 or 2008 model year Saturn AURA, your satisfaction with our product is very important to us.

This letter is intended to make you aware that some 2007 and 2008 model year Saturn AURA vehicles equipped with a 4-speed automatic transmission have a condition in which the transmission shift cable may fracture. As the fracture begins, the driver may have a difficult time selecting a gear or removing the key from the ignition. If these warnings are ignored, the cable could continue to fracture and shift function could be lost. The driver may not be able to restart the vehicle or shift the vehicle into PARK, allowing the vehicle to roll away if the driver has exited the vehicle without applying the park brake.

Do not take your vehicle to your GM dealer as a result of this letter unless you believe that your vehicle has the condition as described above.

*What We Have Done:* General Motors is providing owners with additional protection for this condition. If this condition occurs on your 2007 or 2008 model year Saturn AURA within 10 years of the date your vehicle was originally placed in service or 120,000 miles (193,000 km), whichever occurs first, the condition will be repaired for you at *no charge*. Diagnosis or repair for conditions other than the condition described above is not covered under this special coverage program.

*What You Should Do:* If you believe that your vehicle has the condition described above, repairs and adjustments qualifying under this special coverage must be performed by a General Motors dealer. You may want to contact your GM dealer to find out how long they will need to have your vehicle so that you may schedule the appointment at a time that is convenient for you. This will

also allow your dealer to order parts if they are not already in stock. Keep this letter with your other important glove box literature for future reference.

*Reimbursement:* If you have paid for repairs for the condition described in this letter, please complete the enclosed form and present it to your dealer with all required documents. Working with your dealer will expedite your request, however, if this is not convenient, you may mail the completed form and all required documents to Reimbursement Department, PO Box 33170, Detroit, MI 48232-5170. The completed form and required documents must be presented to your dealer or received by the Reimbursement Department by December 31, 2012, unless state law specifies a longer reimbursement period.

If you have any questions or need any assistance, just contact your dealer or the appropriate Customer Assistance Center at the number listed below.

<i>Division</i>	<i>Number</i>	<i>Text Telephones (TTY)</i>
Saturn	1-800-553-6000	1-800-833-6000
Guam	65-6267-1752	
Puerto Rico – English	1-800-496-9992	
Puerto Rico – Español	1-800-496-9993	
Virgin Islands	1-800-496-9994	

We are sorry for any inconvenience you may experience; however we have taken this action in the interest of your continued satisfaction with our products.

Jim Moloney

General Director,

Customer and Relationship Services

Enclosure

11175

GM bulletins are intended for use by professional technicians, NOT a "do-it-yourselfer". They are written to

inform these technicians of conditions that may occur on some vehicles, or to provide information that could assist in the proper service of a vehicle. Properly trained technicians have the equipment, tools, safety instructions, and know-how to do a job properly and safely. If a condition is described, DO NOT assume that the bulletin applies to your vehicle, or that your vehicle will have that condition. See your GM dealer for information on whether your vehicle may benefit from the information.



WE SUPPORT  
VOLUNTARY  
TECHNICIAN  
CERTIFICATION