

PE10-049

GM 1-27-2011

Q 13

Service Bulletin

PIE0129

Document ID: 2542364

#PIE0129: EI00345-Engineering Information-Engine Cooling Fan Breakage, Engine Coolant Leak, Engine Knock Noise - (Oct 29, 2010)

Subject: EI00345 -- Engineering Information -- Engine Cooling Fan Breakage, Engine Coolant Leak, Engine Knock Noise



Models: 2006-2007 Chevrolet Kodiak C4500/C5500 Series
2006-2007 GMC TopKick C4500/C5500 Series
Equipped with 6.6L Diesel Engine RPOs LLY or LMM

Attention: Proceed with this PI ONLY if the customer has commented about this concern AND the EI number is listed in the Global Warranty Management / Investigate History link (GWM/IVH). If the customer has not commented about this condition or the EI does not show in GWM/IVH, disregard the PI and proceed with diagnostics found in published service information. THIS IS NOT A RECALL -- refer to Service Bulletin 04-00-89-053D for more details on the use of Engineering Information PIs.

Condition

Important: If the customer did not bring their vehicle in for this concern, DO NOT proceed with this PI.

Some customers may comment on an engine coolant leak or an engine knock noise. Further inspection may reveal engine cooling fan breakage.

Cause

GM Engineering is attempting to determine the root cause of the engine cooling fan breakage. Engineering has a need to gather information on vehicles PRIOR to repair that may exhibit this condition. As a result, this information will be used to "root cause" the customer's concern and develop/validate a field fix.

Instructions

If you encounter a vehicle with the above concern, please contact the engineer listed below for additional instructions. The engineer may request parts back. Parts will be requested back using the WPC process.

Contact Information

Engineer Name	Phone Number
Tom Lockwood	(586) 291-8056

© 2011 General Motors. All rights reserved.

If the engineer is unable to take your call, please leave the information listed below in a message.

- Technician name
- Dealer name and phone number
- Complete VIN and repair order (R.O) number

On the repair order, document the date and time the call was placed (even if the engineer was not reached).

If engineering is unable to return the call within one hour, proceed with diagnosis and repair based on information found in SI.

Warranty Information

If engineer was contacted or required information was provided, use:

Labor Operation	Description	Labor Time
J7623*	Engineering Information - Engine Cooling Fan	0.2 hr
* This is a unique labor operation for PI use only. It will not be published in the Labor Time Guide.		

GM bulletins are intended for use by professional technicians, NOT a "do-it-yourselfer". They are written to inform these technicians of conditions that may occur on some vehicles, or to provide information that could assist in the proper service of a vehicle. Properly trained technicians have the equipment, tools, safety instructions, and know-how to do a job properly and safely. If a condition is described, DO NOT assume that the bulletin applies to your vehicle, or that your vehicle will have that condition. See your GM dealer for information on whether your vehicle may benefit from the information.



WE SUPPORT
VOLUNTARY
TECHNICIAN
CERTIFICATION

PE10-049

GM 1-27-2011

Q2

Engineering sketches

2006 MY L18 Engine Cooling Fan and Related Components: Exploded view

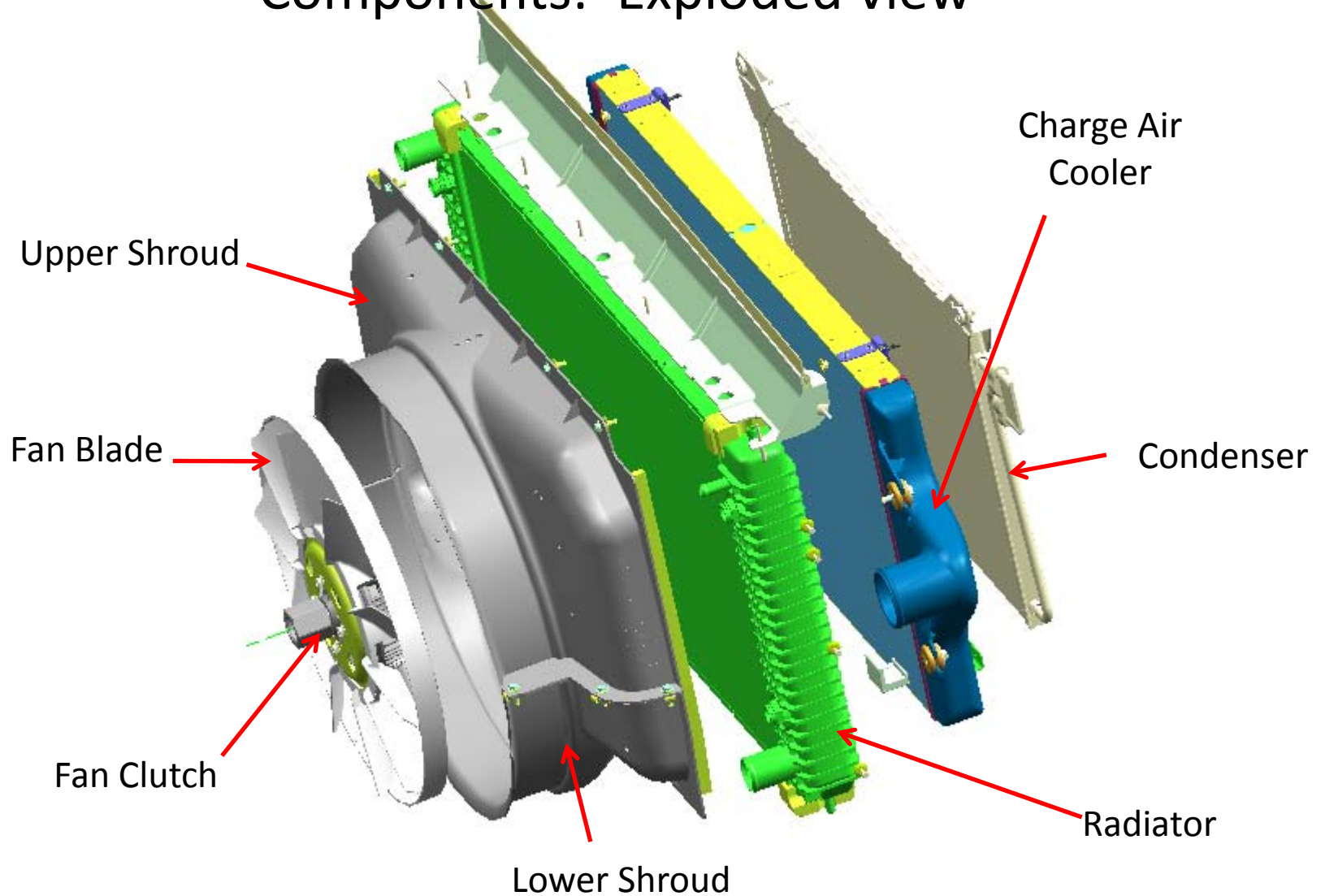

2006 MY L18 Engine Cooling
Fan and Related Components:
Isometric view

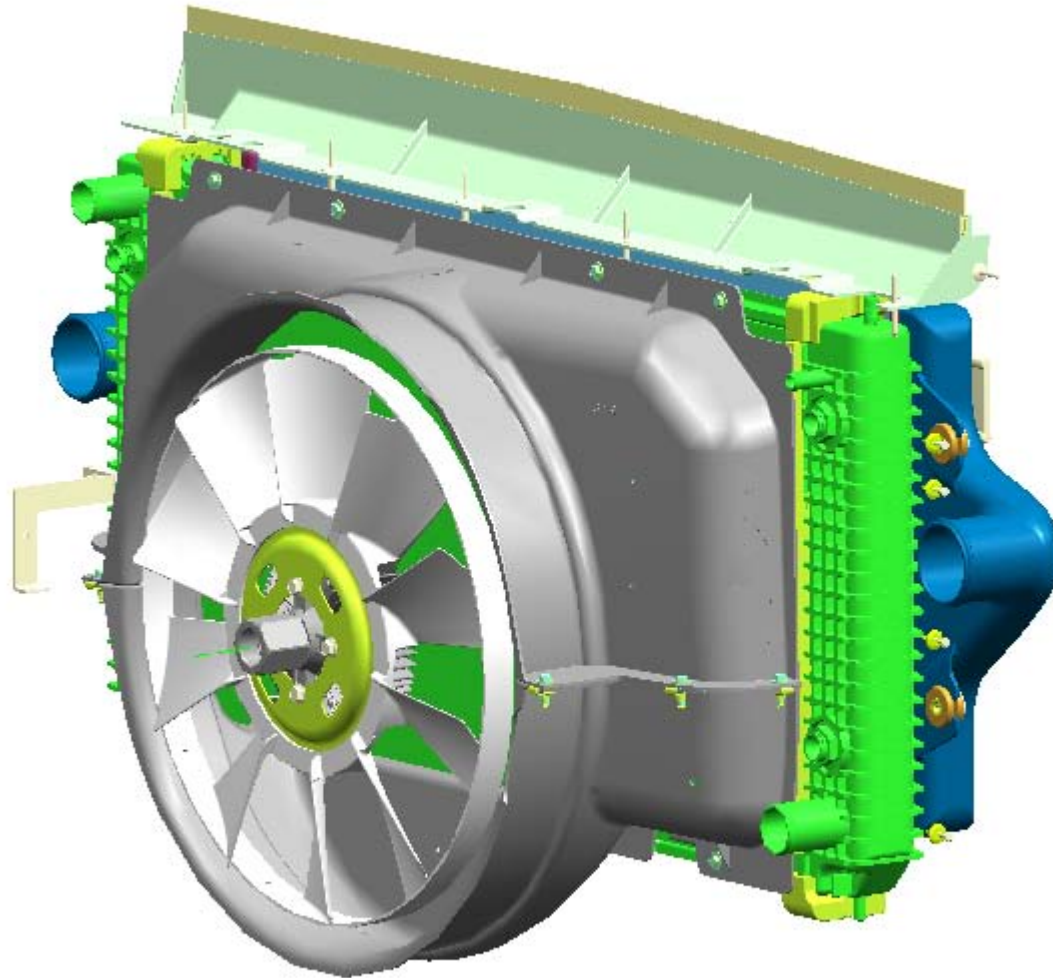

2006 MY L18 Engine Cooling Fan and Related Components: Rear view

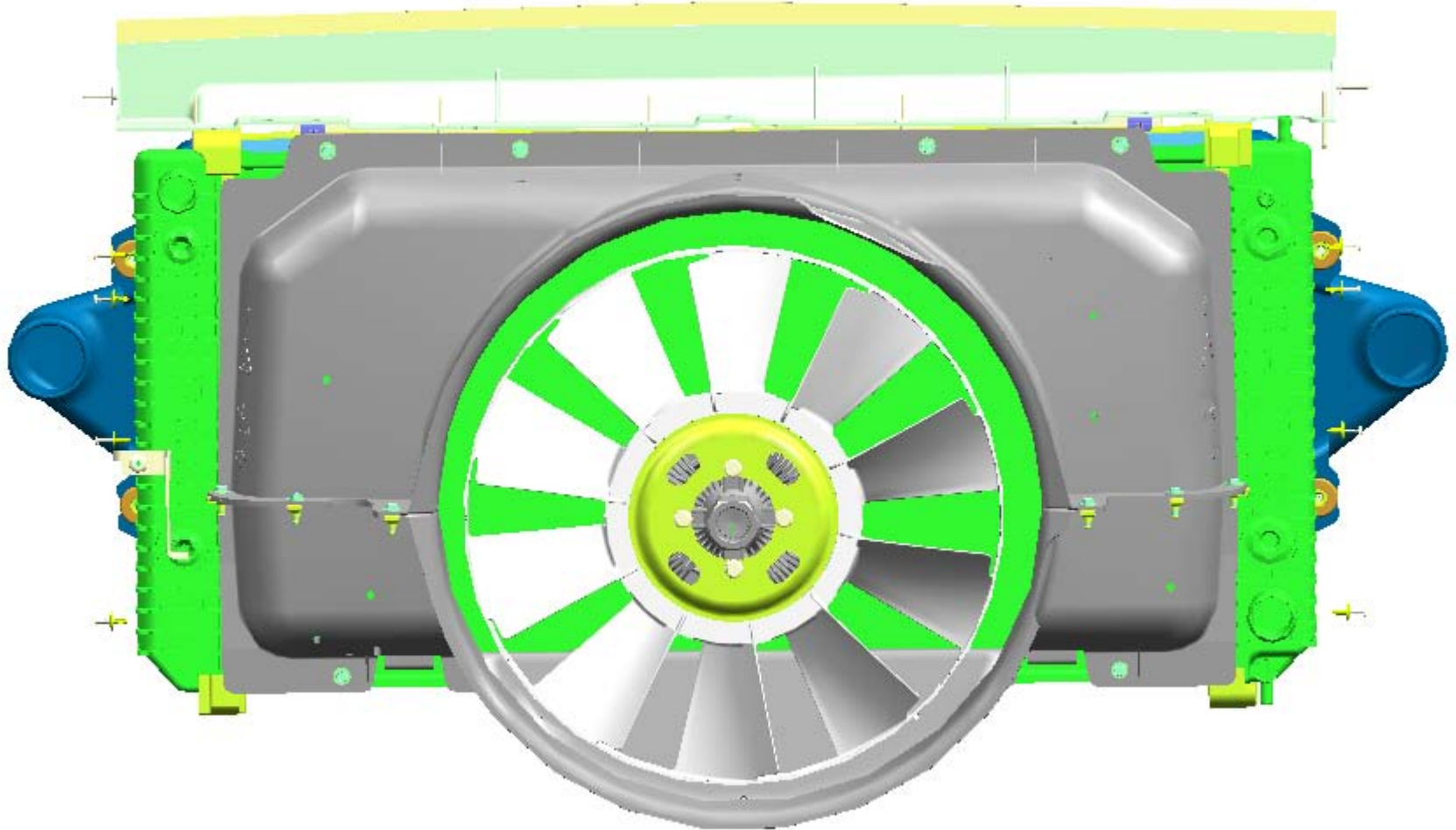

2006 MY L18 Engine Cooling Fan and Related Components: Right view

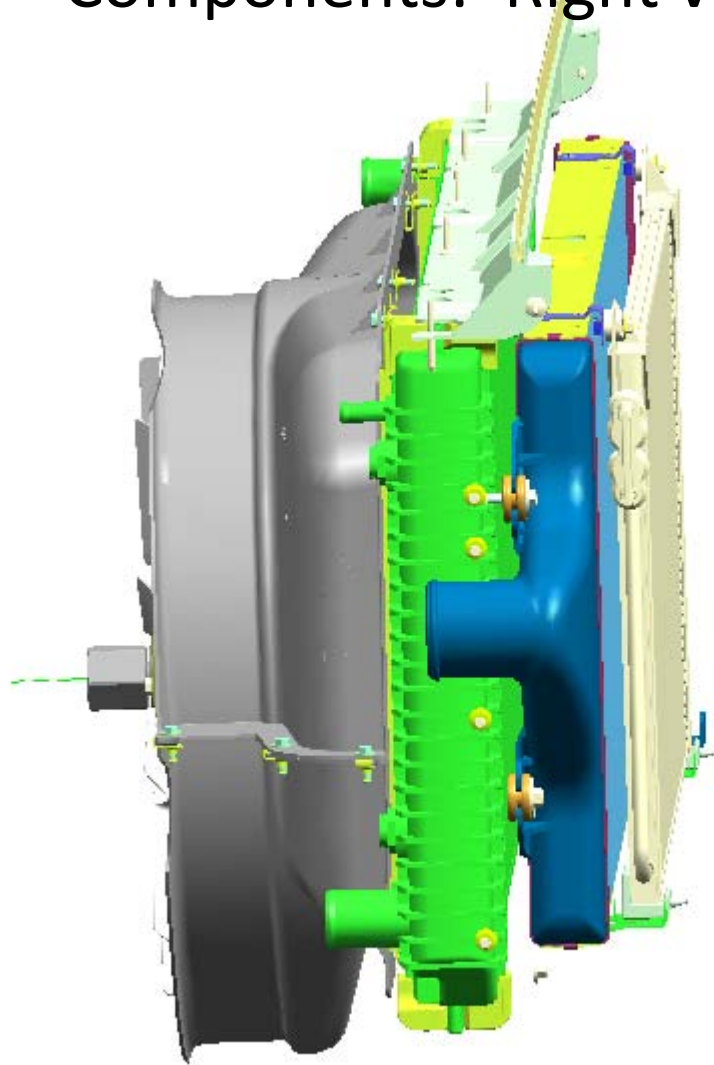

2006 MY LLY Engine Cooling Fan and Related Components: Exploded view

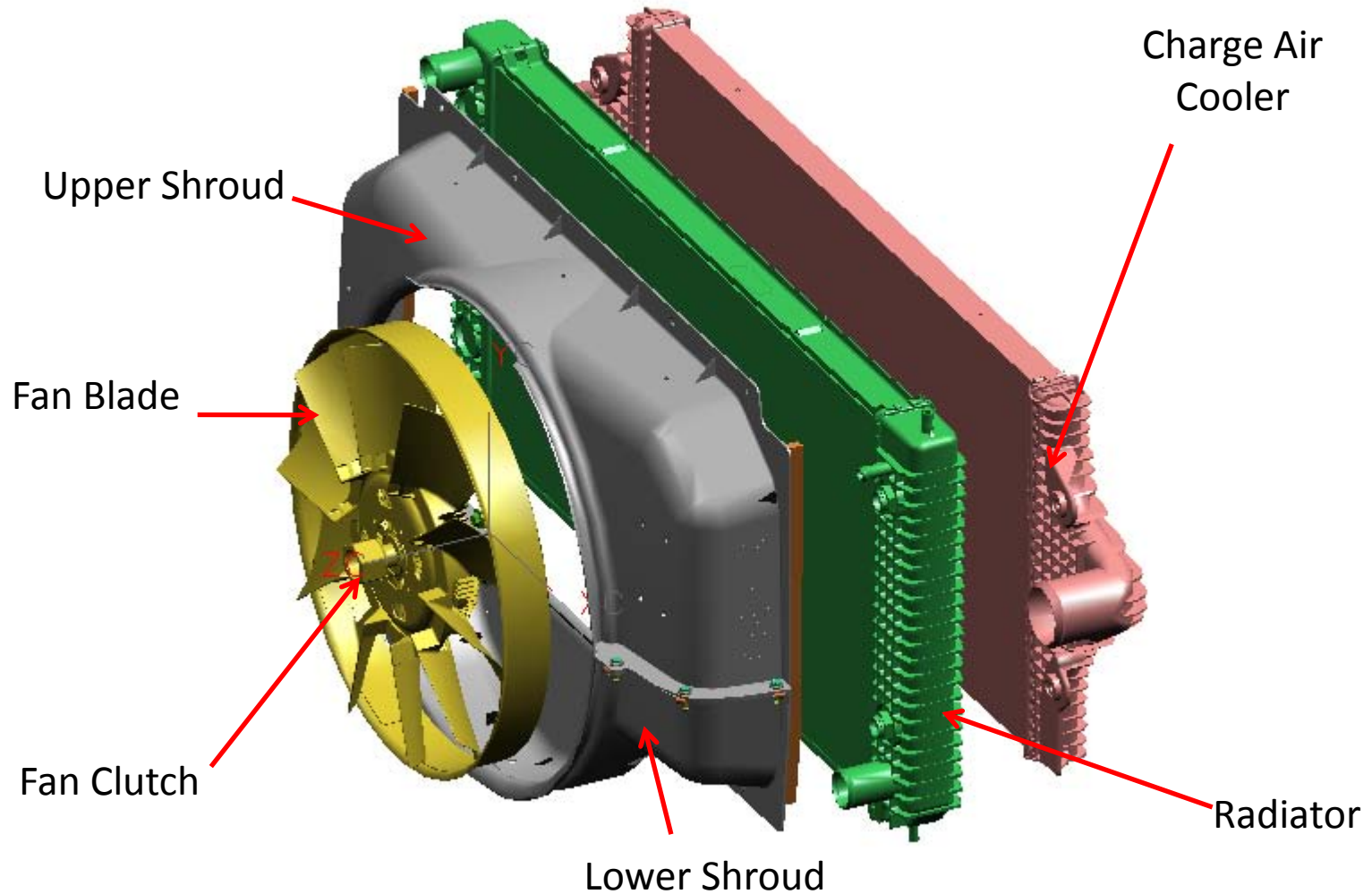

2006 MY LLY Engine Cooling Fan and Related Components: Isometric view

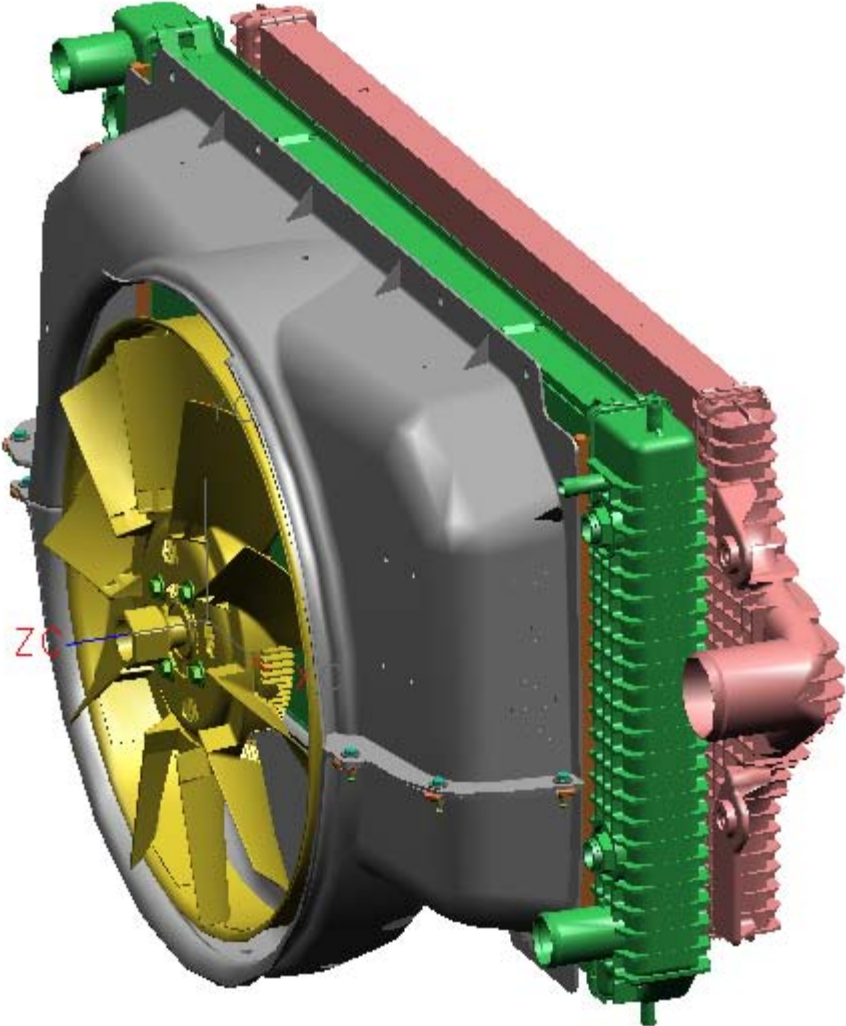

2006 MY LLY Engine Cooling Fan and Related Components: Rear view

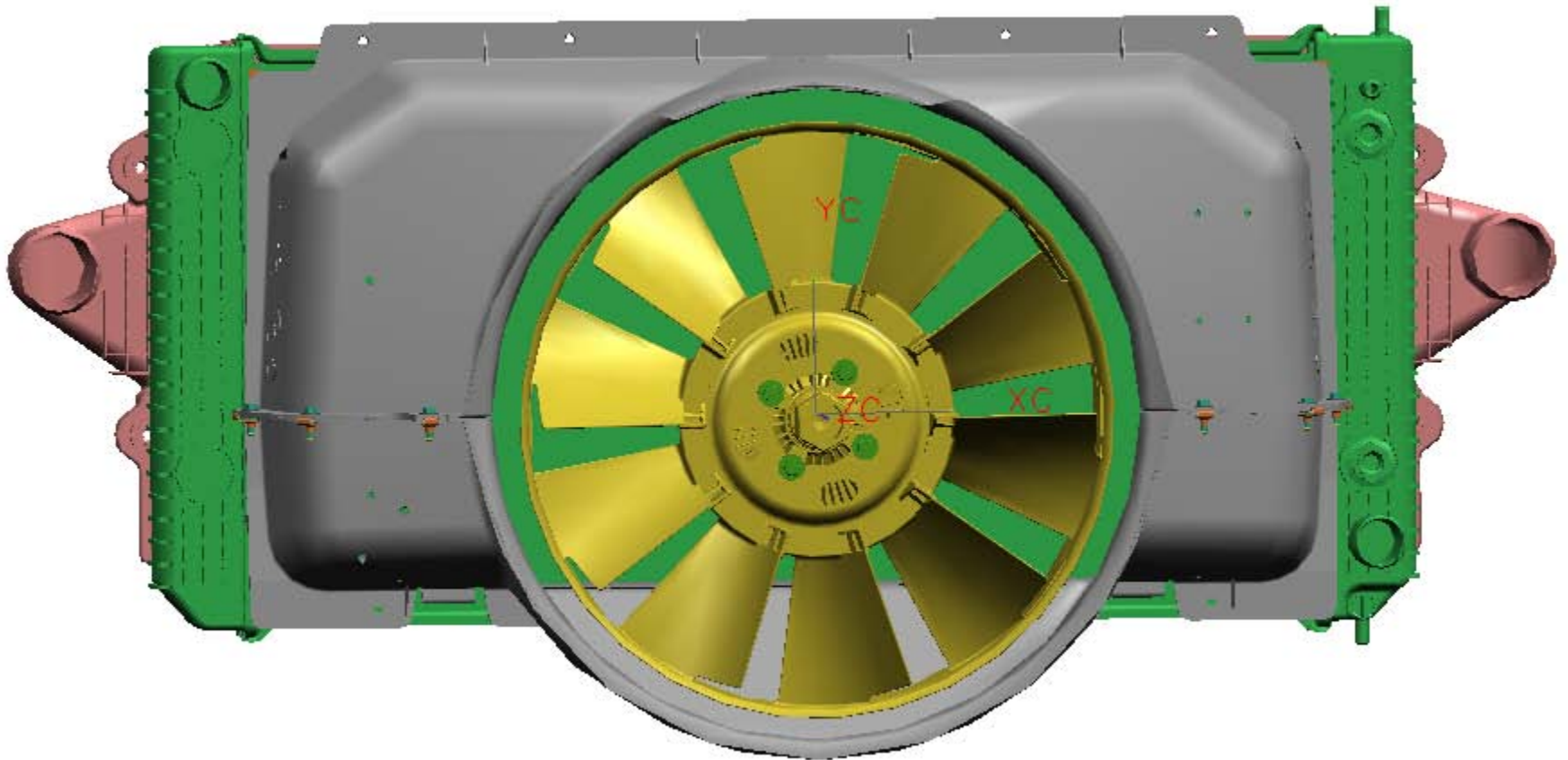

2006 MY LLY Engine Cooling Fan and Related Components: Right view

