

NHTSA Peer IR PE10-31_N100337

Design / Material History

Old Blazer (2 door & 4 door, fuel tank behind rear axle)

1993 – 1994

Steel fuel tank (UPC 8A, FNA 0025A)
Optional HDPE shield (UPC 8A, FNA 3675A)
HDPE shield (UPC 8A, FNA 3700A)

GMT-330 Blazer (2 door, fuel tank behind rear axle)

1995 – 2002

Steel fuel tank (UPC 8A, FNA 0025A)
HDPE shield (UPC 8A, FNA 3700A)

2003 – 2004

HDPE fuel tank (UPC 8A, FNA 0025A)
HDPE shield (UPC 8A, FNA 3700A)

GMT-330 Blazer (4 door, fuel tank inside of frame forward of rear axle)

1995 – 1998

Steel fuel tank (UPC 8A, FNA 0025A)
HDPE shields (UPC 8A, FNA 0151A)
Optional Steel shield (UPC 8A, FNA 3675A)

1998 – 2004

HDPE fuel tank (UPC 8A, FNA 0025A)
Optional Polypro w/ glass shield (UPC 8A, FNA 3675A) (RPO ZM5)

NHTSA Peer IR PE10-31_N100337

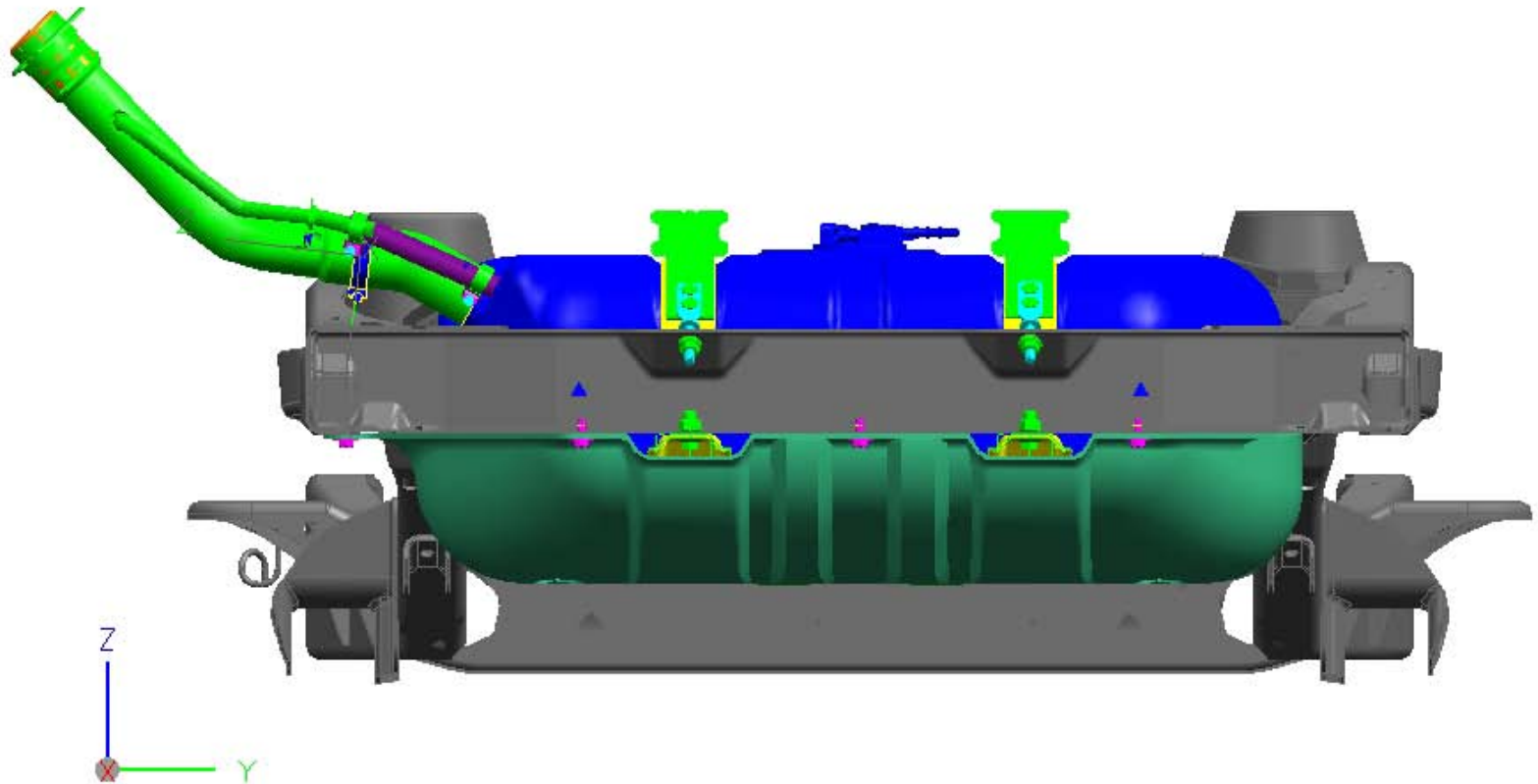

ZC

1993 to 2002 , 2 door Blazer – Rear View

NHTSA Peer IR PE10-31_N100337

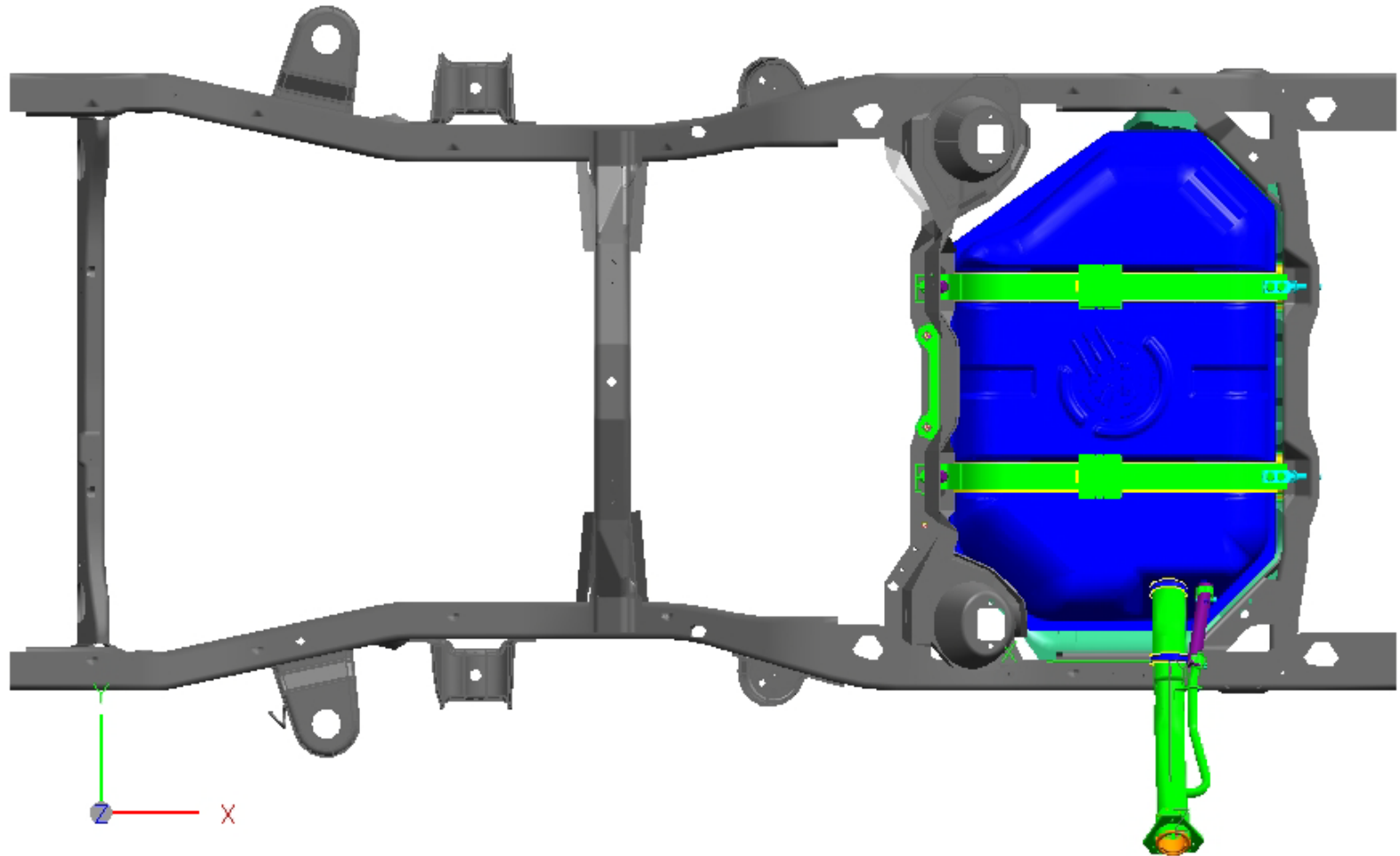

1993 to 2002 , 2 door Blazer – Top View

NHTSA Peer IR PE10-31_N100337

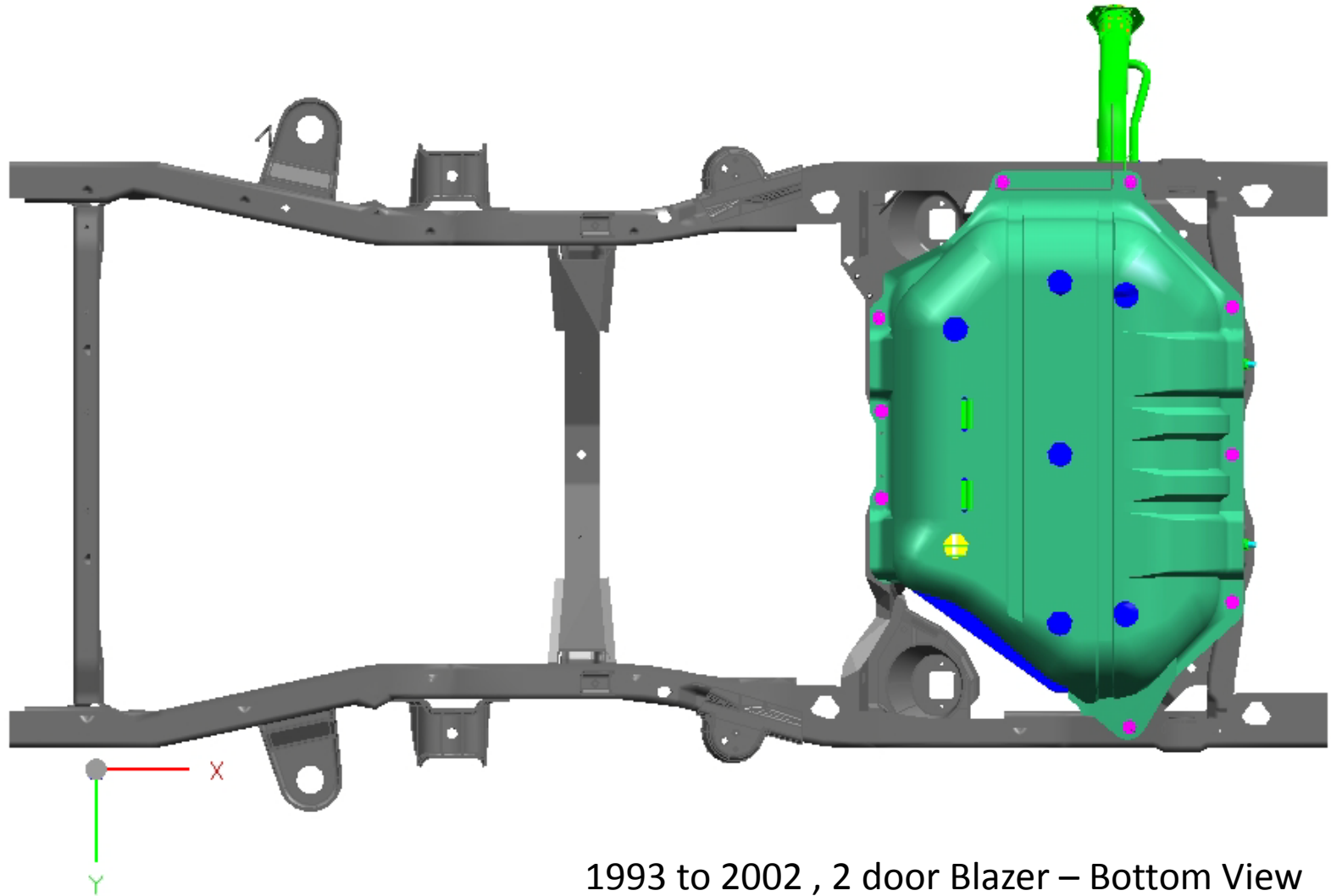

NHTSA Peer IR PE10-31_N100337

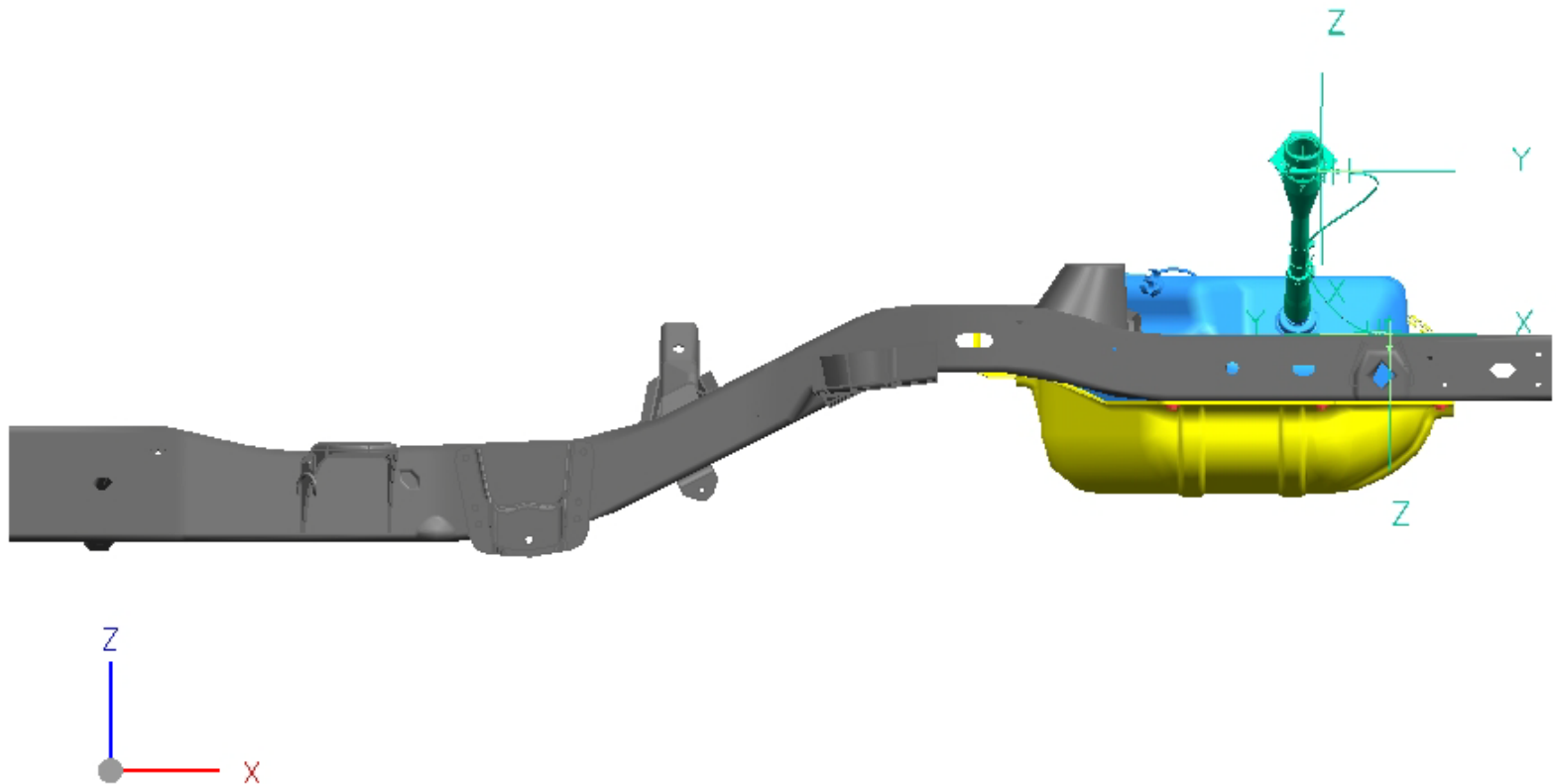

2003 to 2004, 2 door Blazer – Driver Side View
HDPE tank, HDPE shield

NHTSA Peer IR PE10-31_N100337

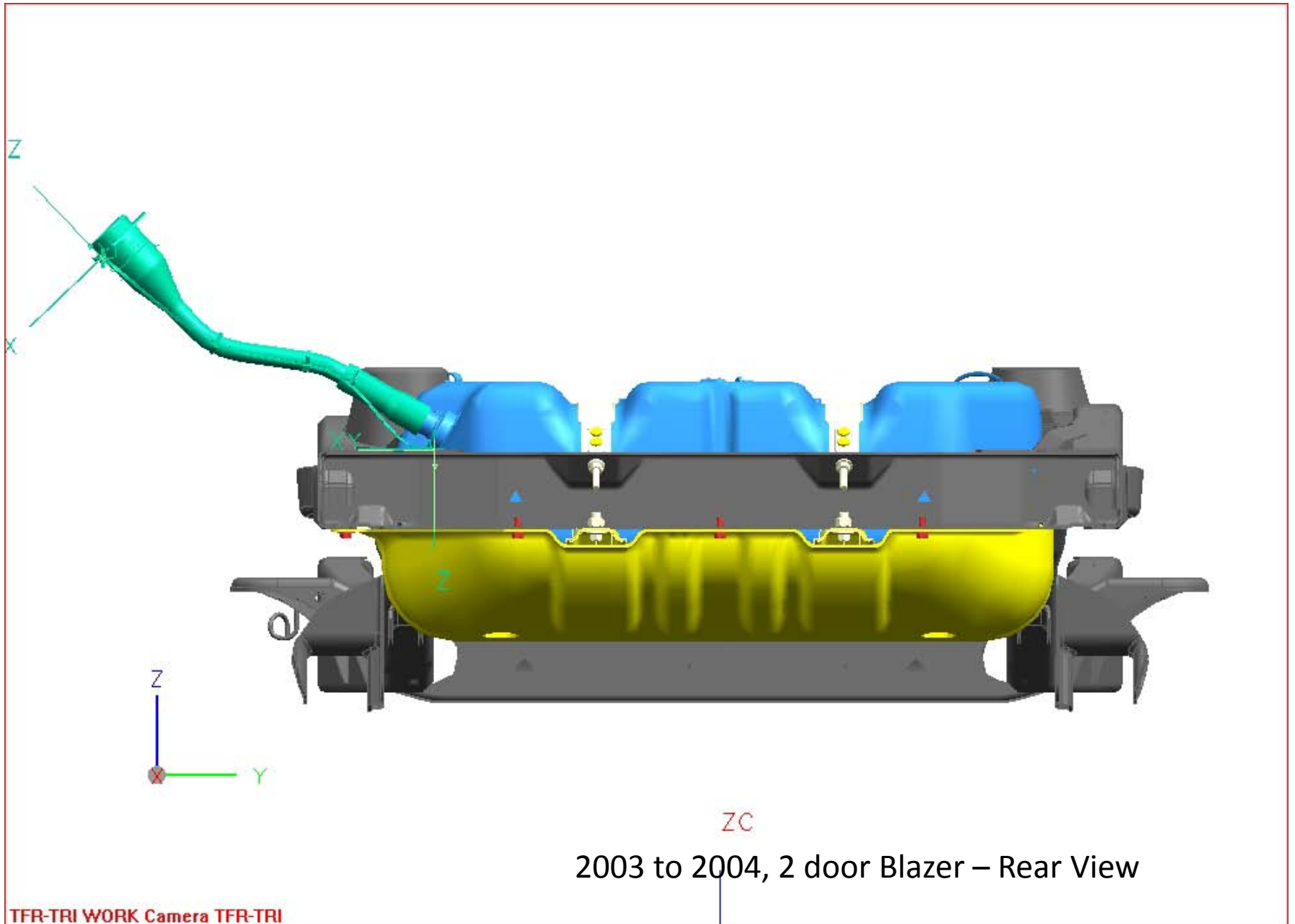

2003 to 2004, 2 door Blazer – Rear View

NHTSA Peer IR PE10-31_N100337

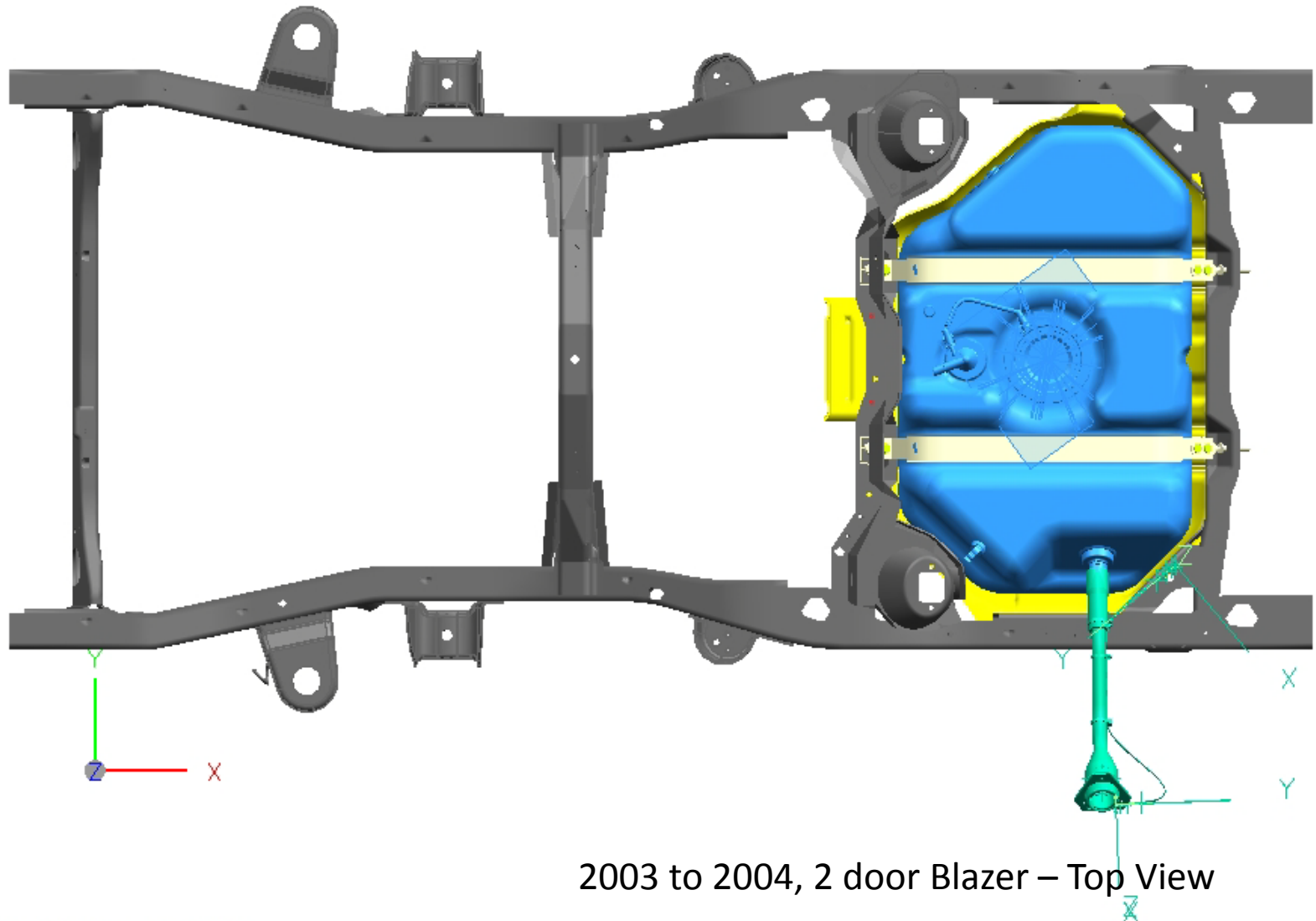

2003 to 2004, 2 door Blazer – Top View

NHTSA Peer IR PE10-31_N100337

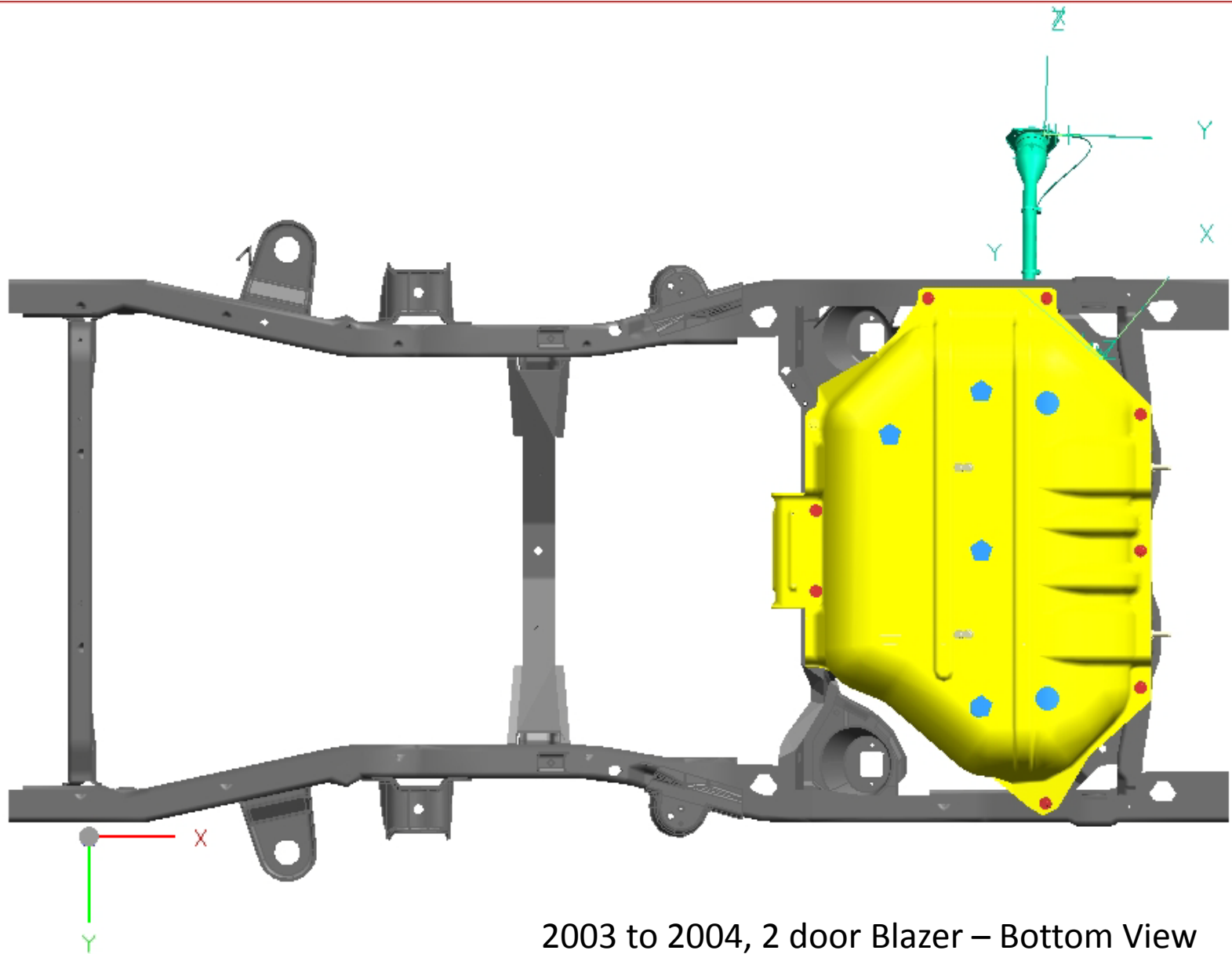

2003 to 2004, 2 door Blazer – Bottom View

NHTSA Peer IR PE10-31_N100337

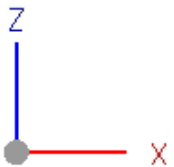
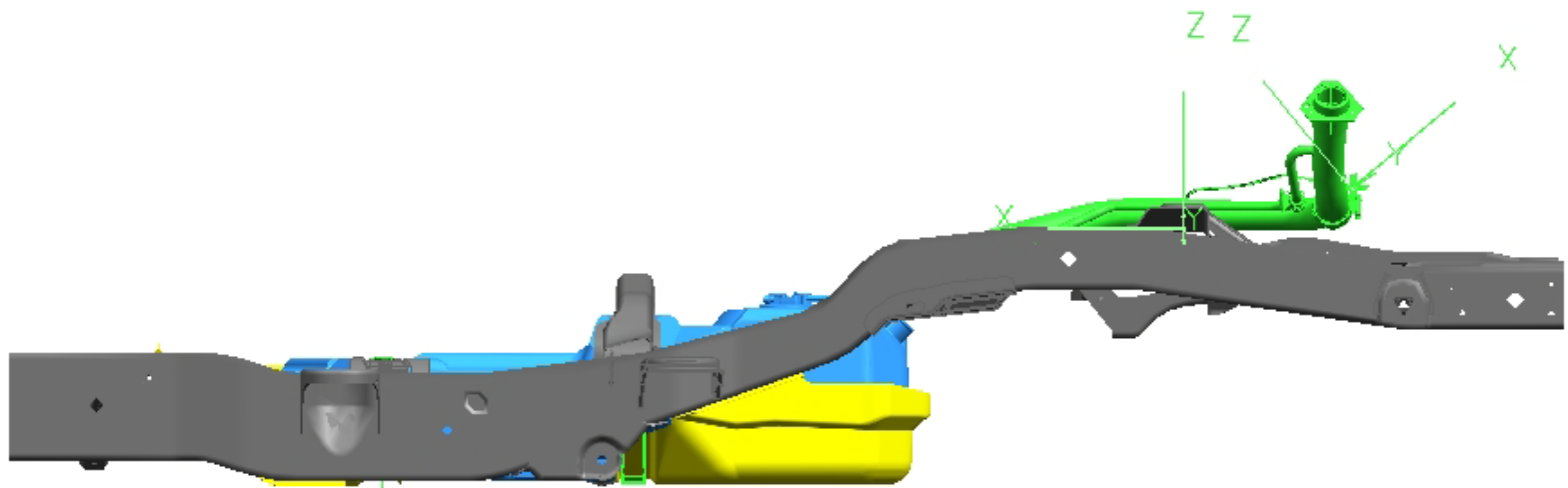

1995 to 1998, 4 door Blazer – Driver side View
Steel tank, HDPE shields

NHTSA Peer IR PE10-31_N100337

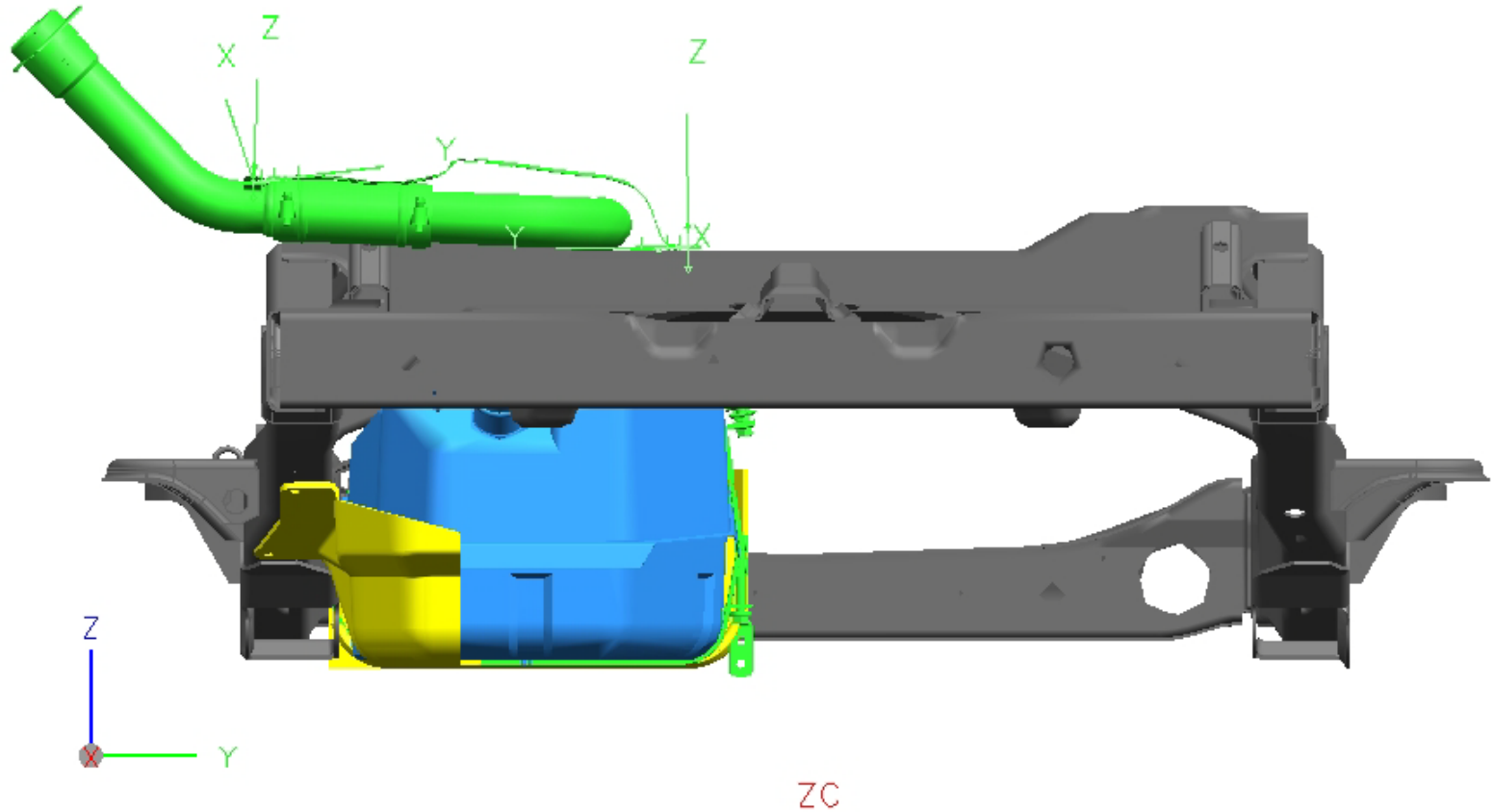

1995 to 1998, 4 door Blazer – Rear View

NHTSA Peer IR PE10-31_N100337

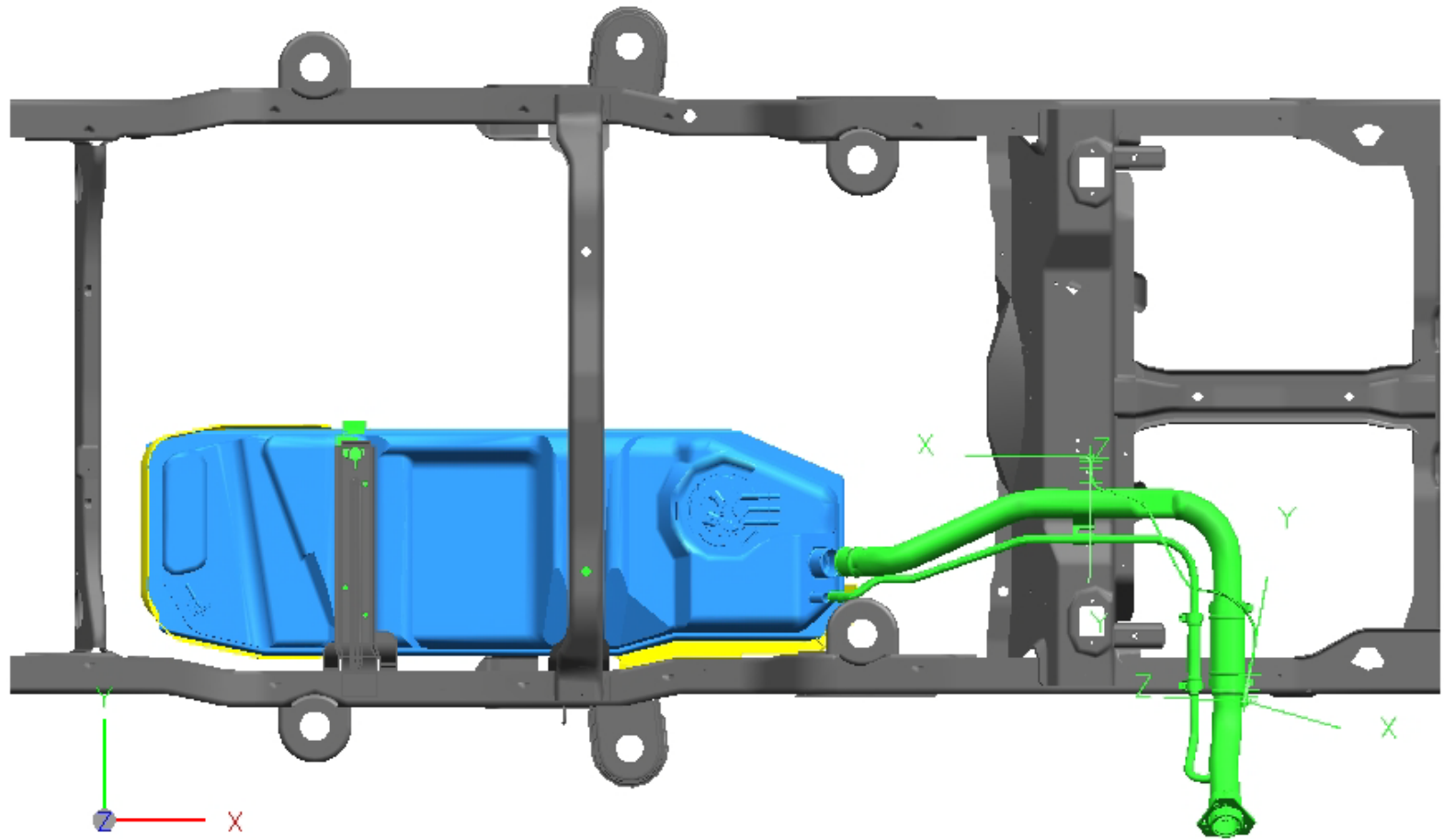

1995 to 1998, 4 door Blazer – Top View

NHTSA Peer IR PE10-31_N100337

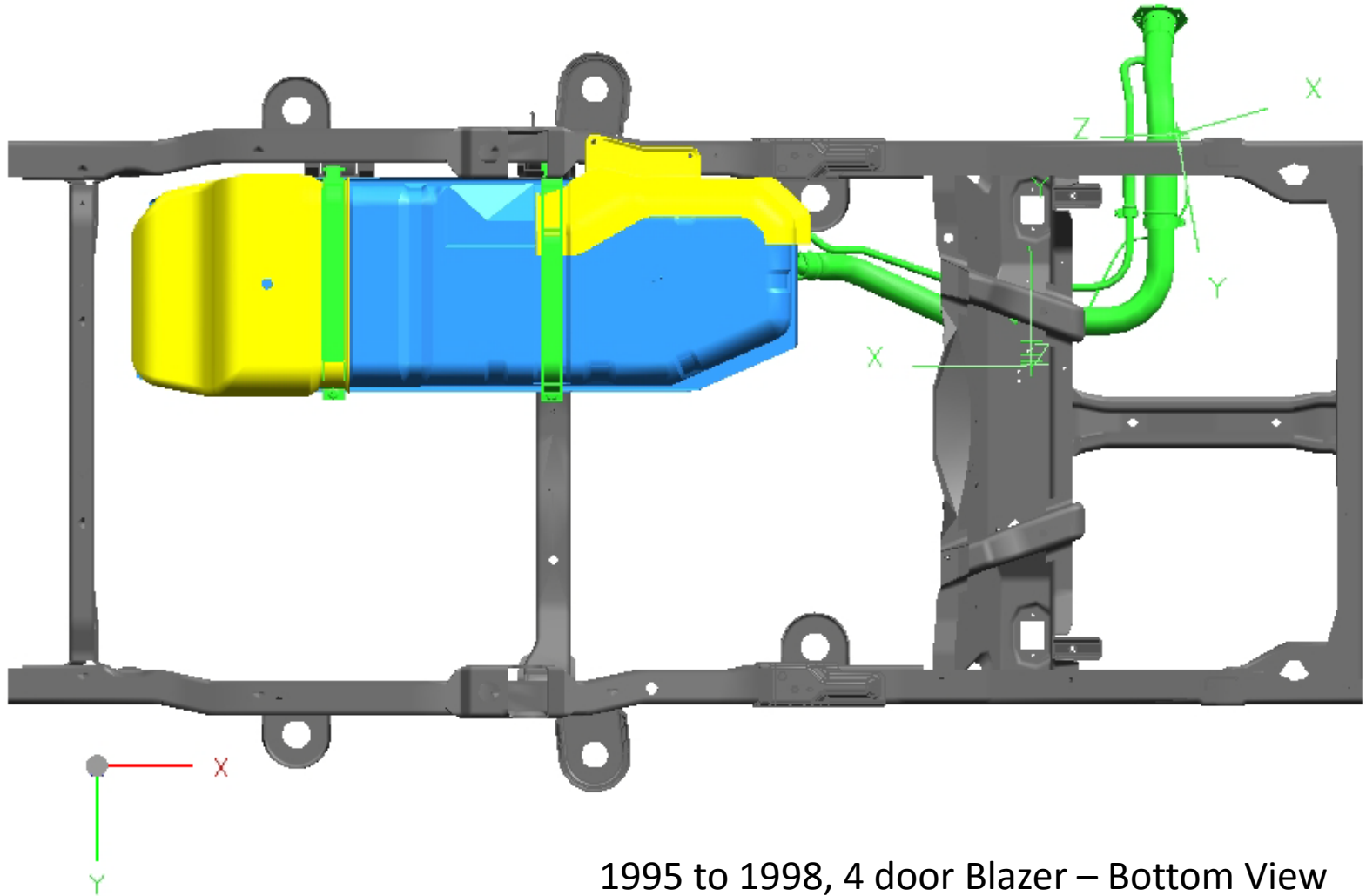

1995 to 1998, 4 door Blazer – Bottom View

NHTSA Peer IR PE10-31_N100337

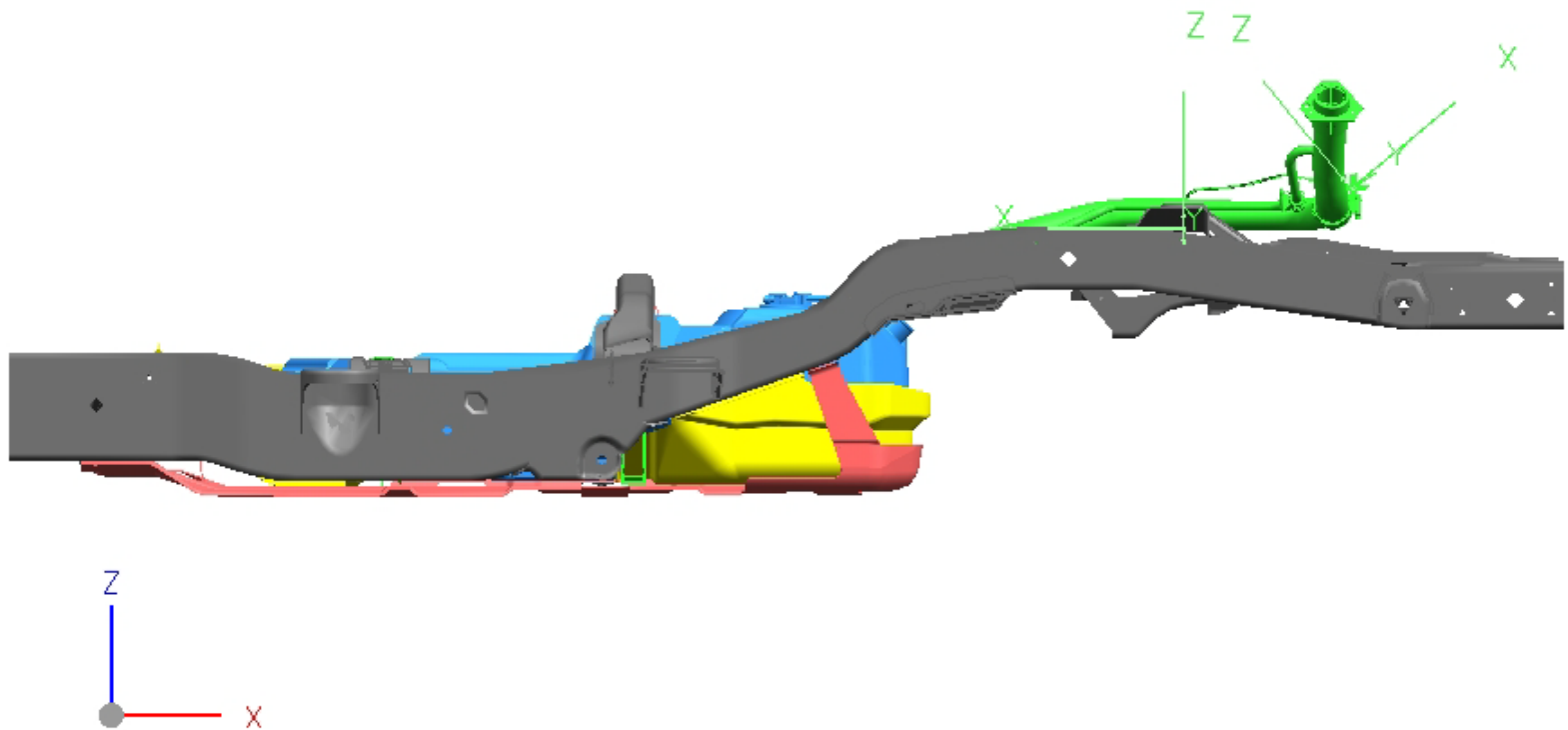

1995 to 1998, 4 door Blazer – Driver side View
Steel tank, HDPE shields, Opt Steel shield

NHTSA Peer IR PE10-31_N100337

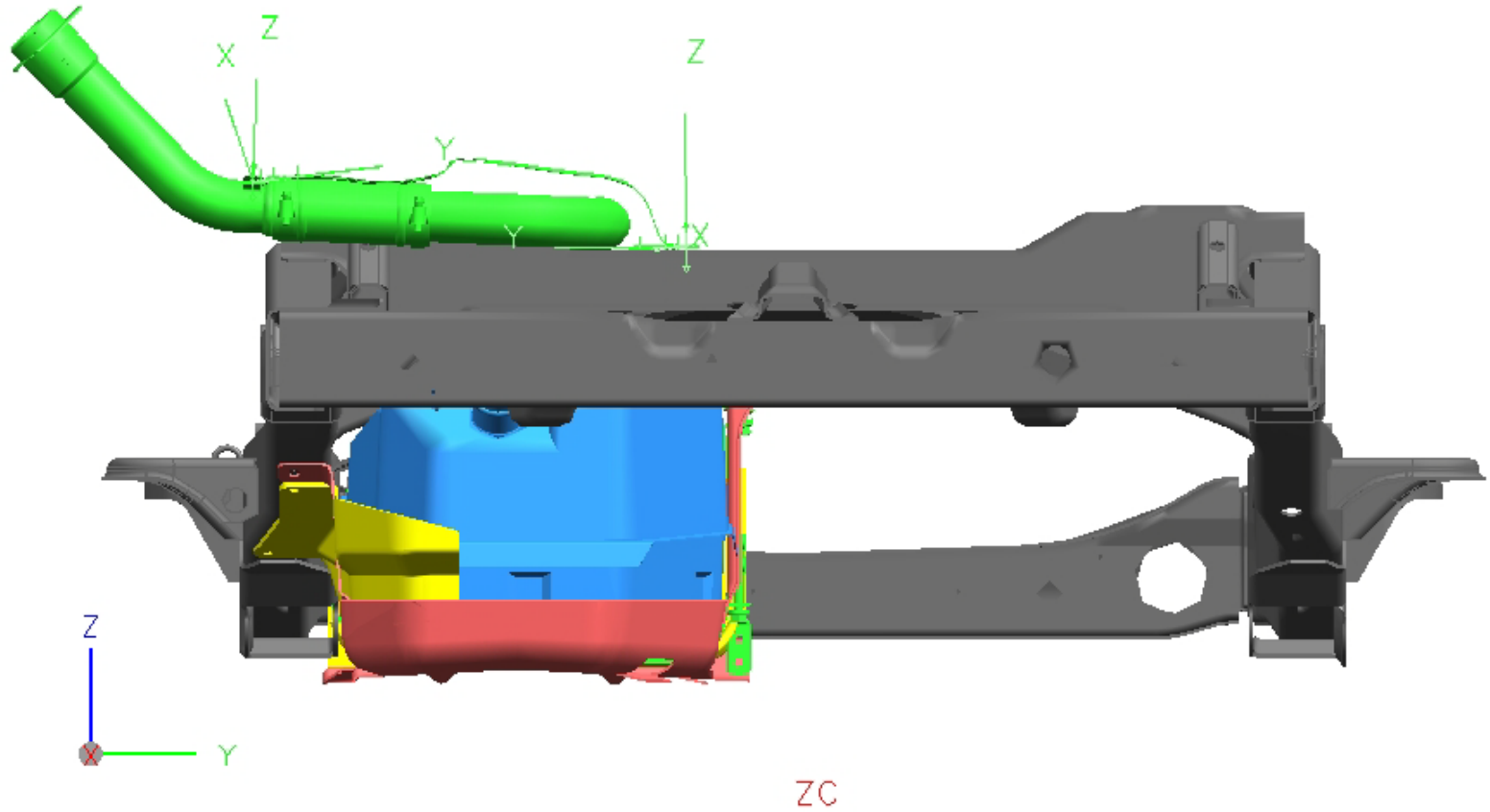

1995 to 1998, 4 door Blazer – Rear View

Opt Steel shield

NHTSA Peer IR PE10-31_N100337

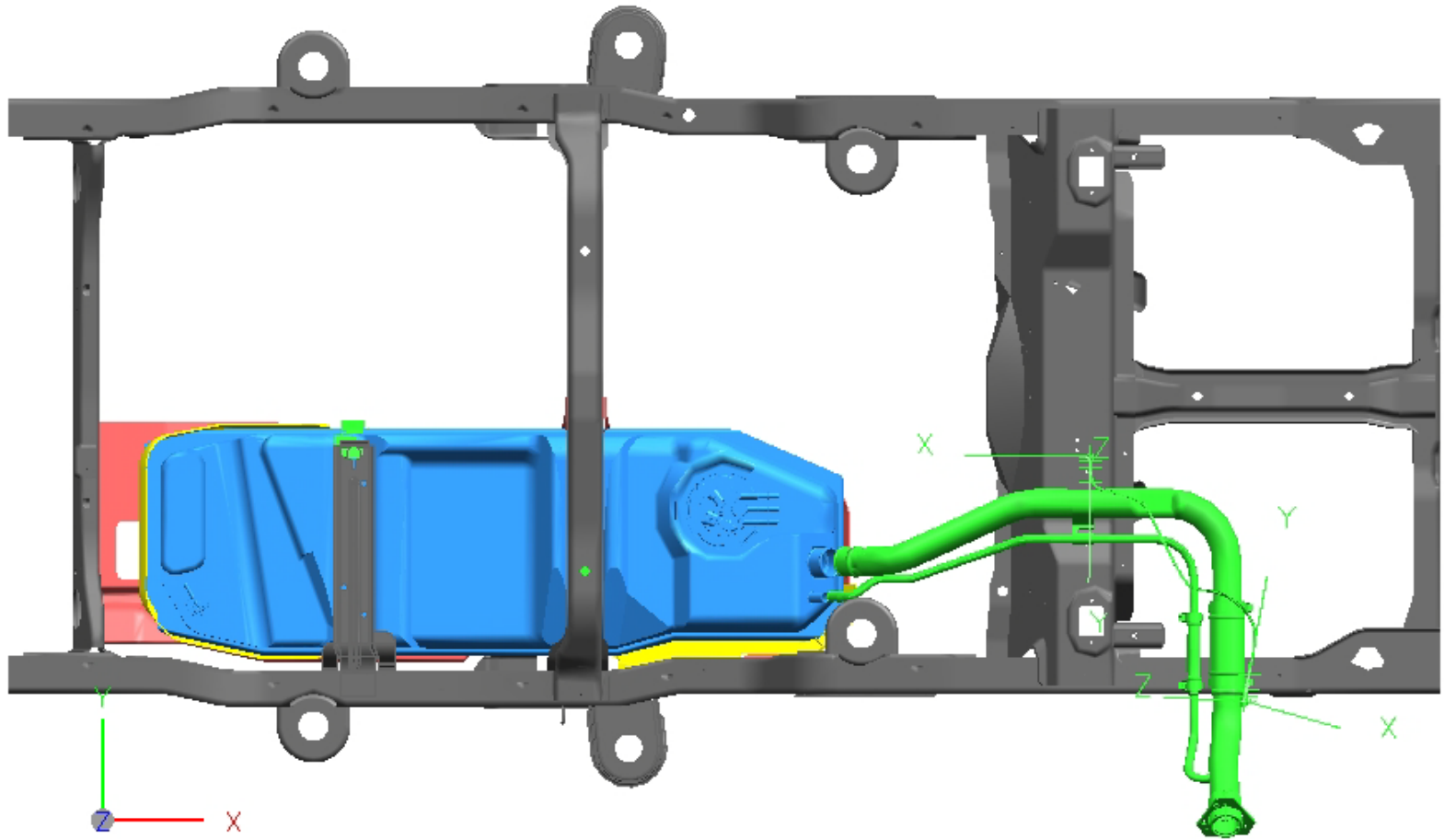

1995 to 1998, 4 door Blazer – Top View

Opt Steel shield

NHTSA Peer IR PE10-31_N100337

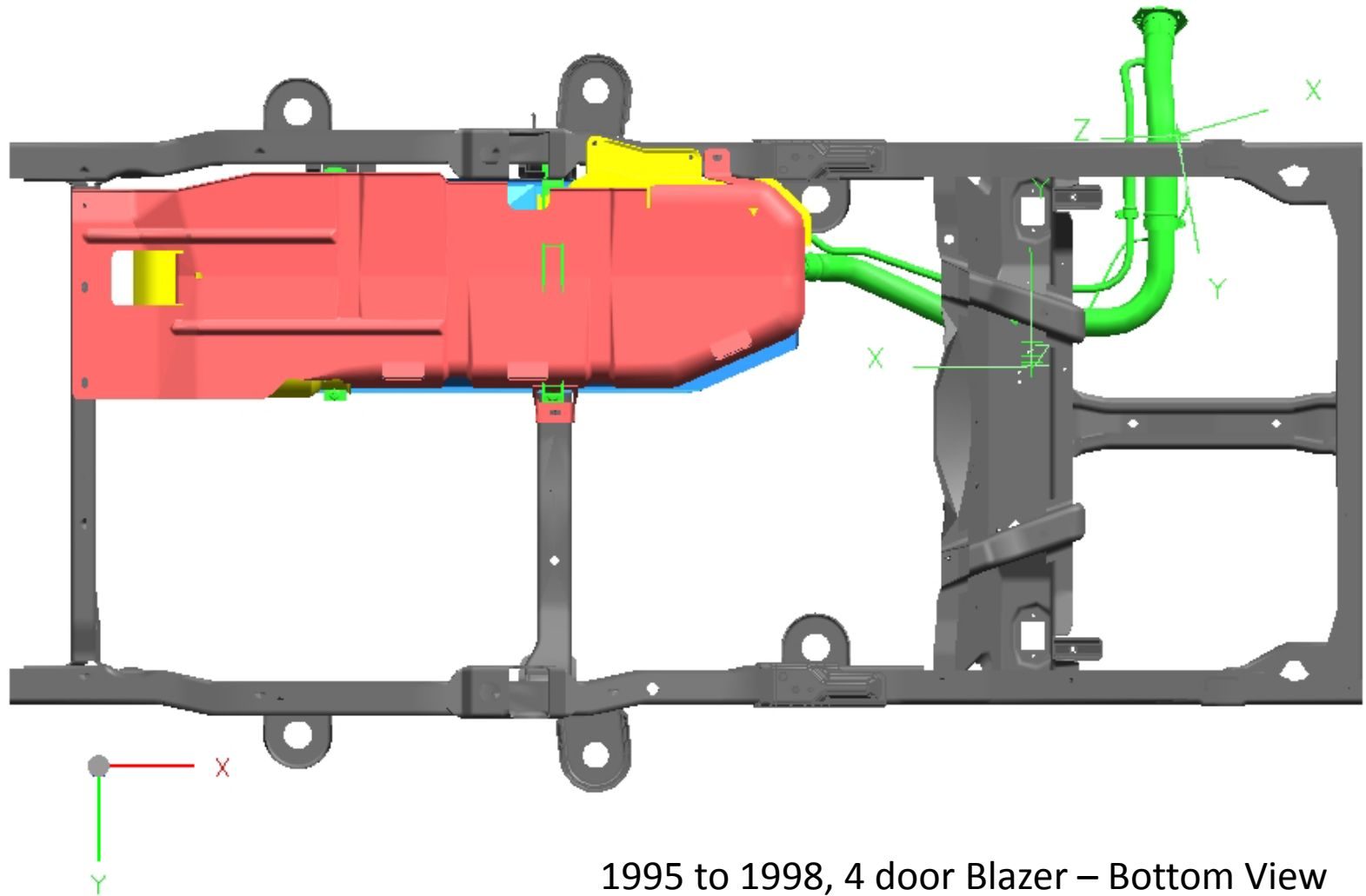

1995 to 1998, 4 door Blazer – Bottom View

Opt Steel shield

NHTSA Peer IR PE10-31_N100337

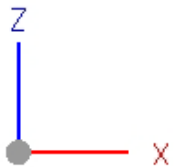
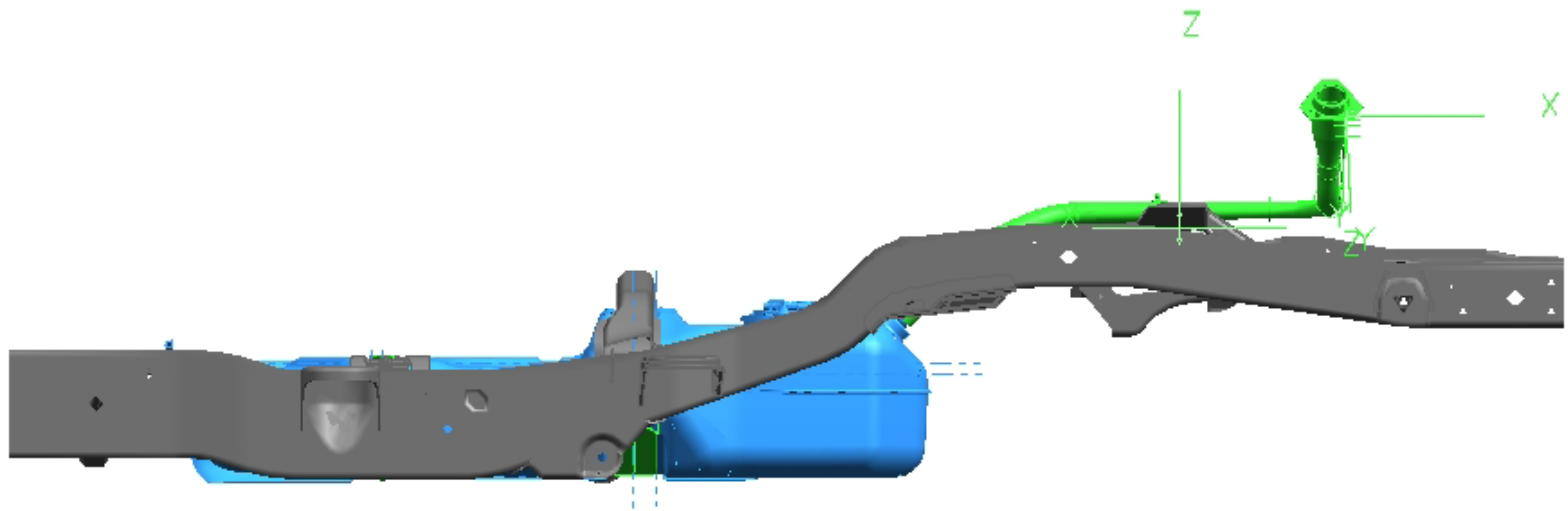

1998 to 2004, 4 door Blazer – Driver side View
HDPE tank,

NHTSA Peer IR PE10-31_N100337

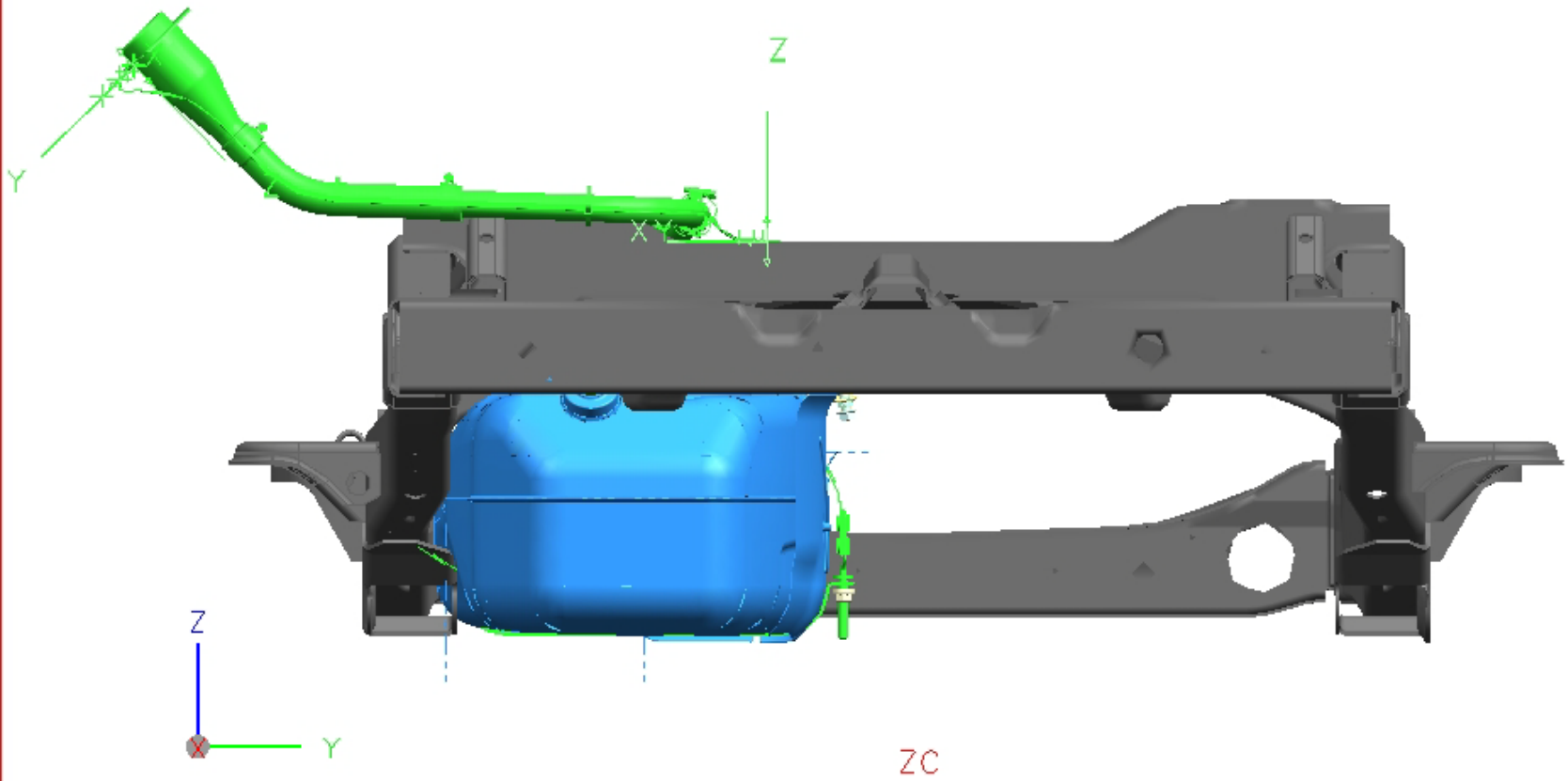

1998 to 2004, 4 door Blazer – Rear View

NHTSA Peer IR PE10-31_N100337

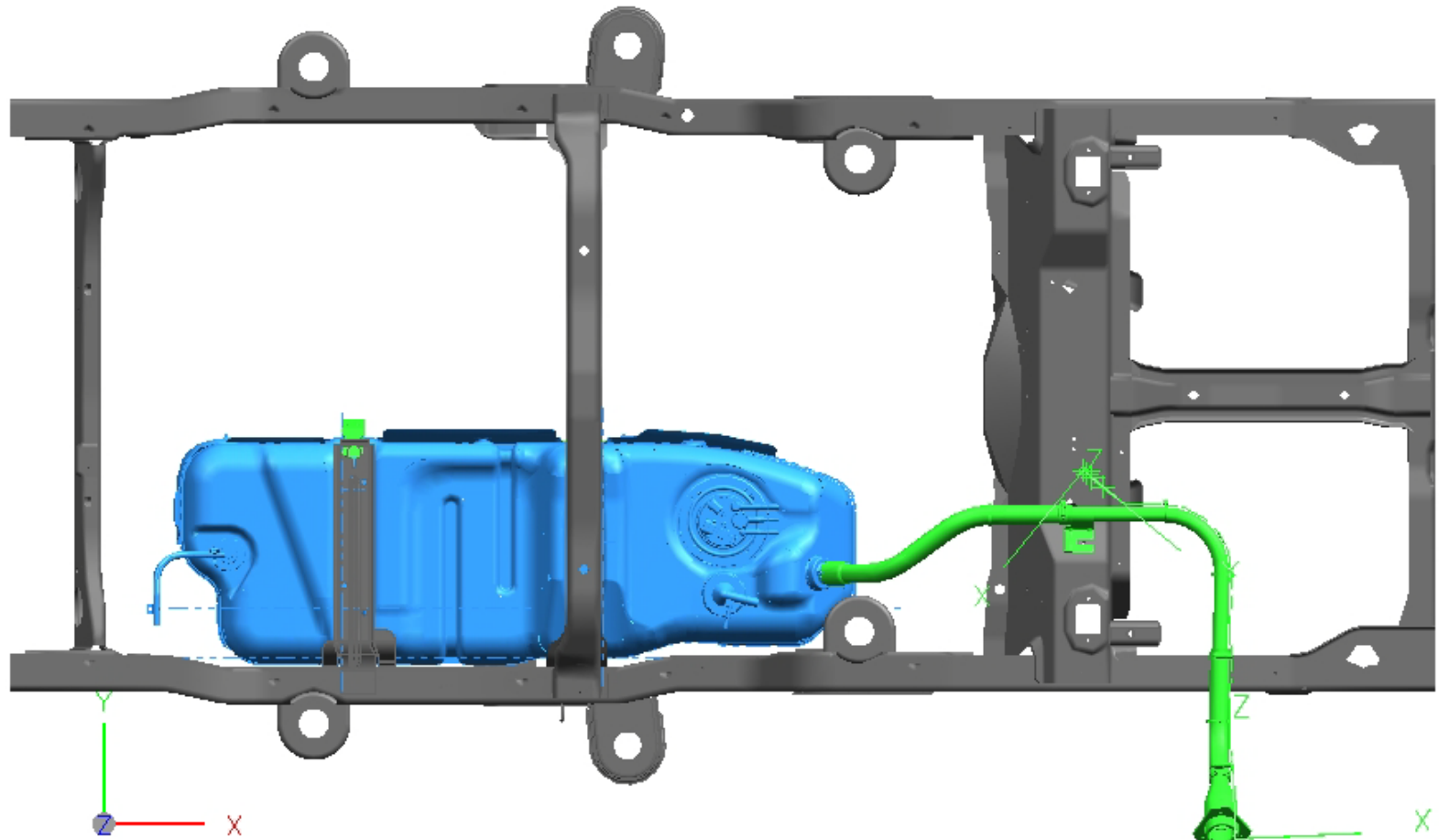

1998 to 2004, 4 door Blazer – Top View

NHTSA Peer IR PE10-31_N100337

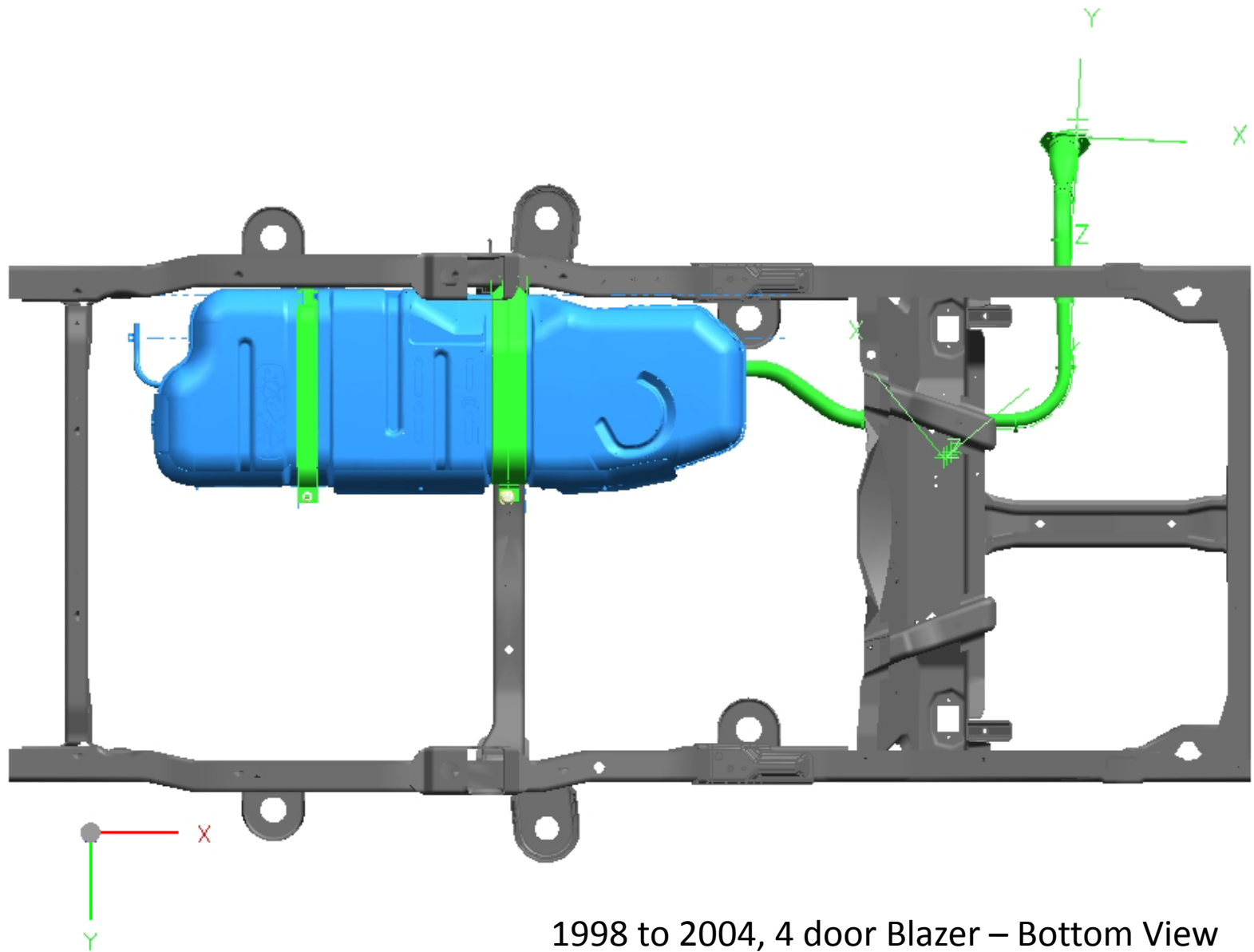

1998 to 2004, 4 door Blazer – Bottom View

NHTSA Peer IR PE10-31_N100337

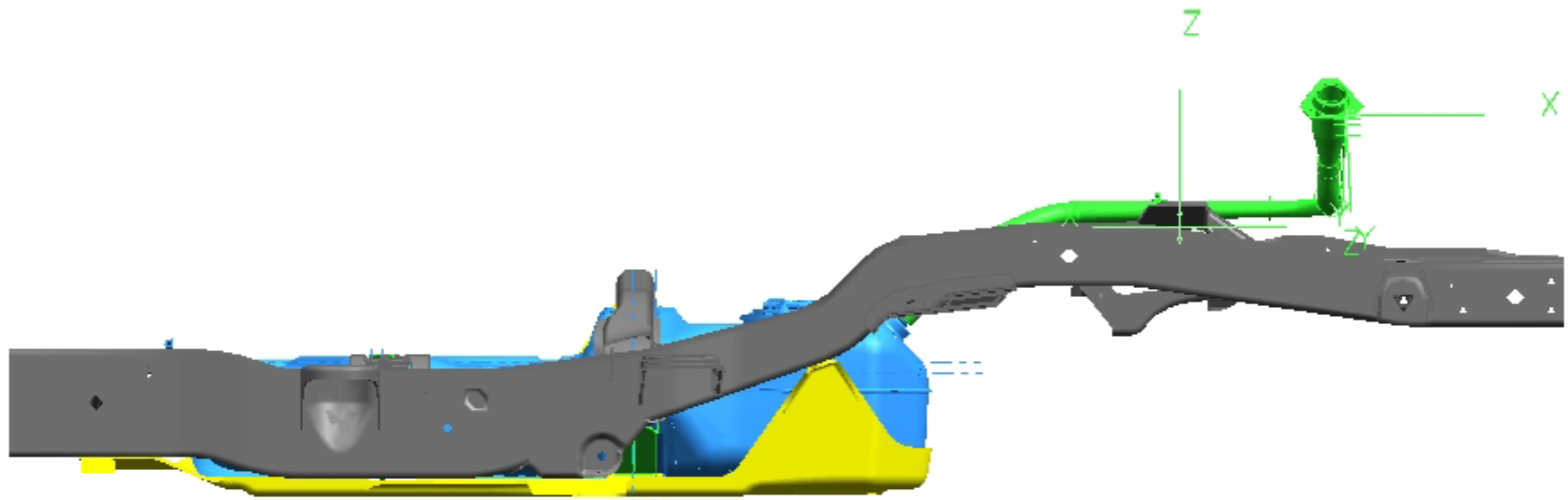

1998 to 2004, 4 door Blazer – Driver side View
HDPE tank, Optional Polypro shield w/ glass reinf.

NHTSA Peer IR PE10-31_N100337

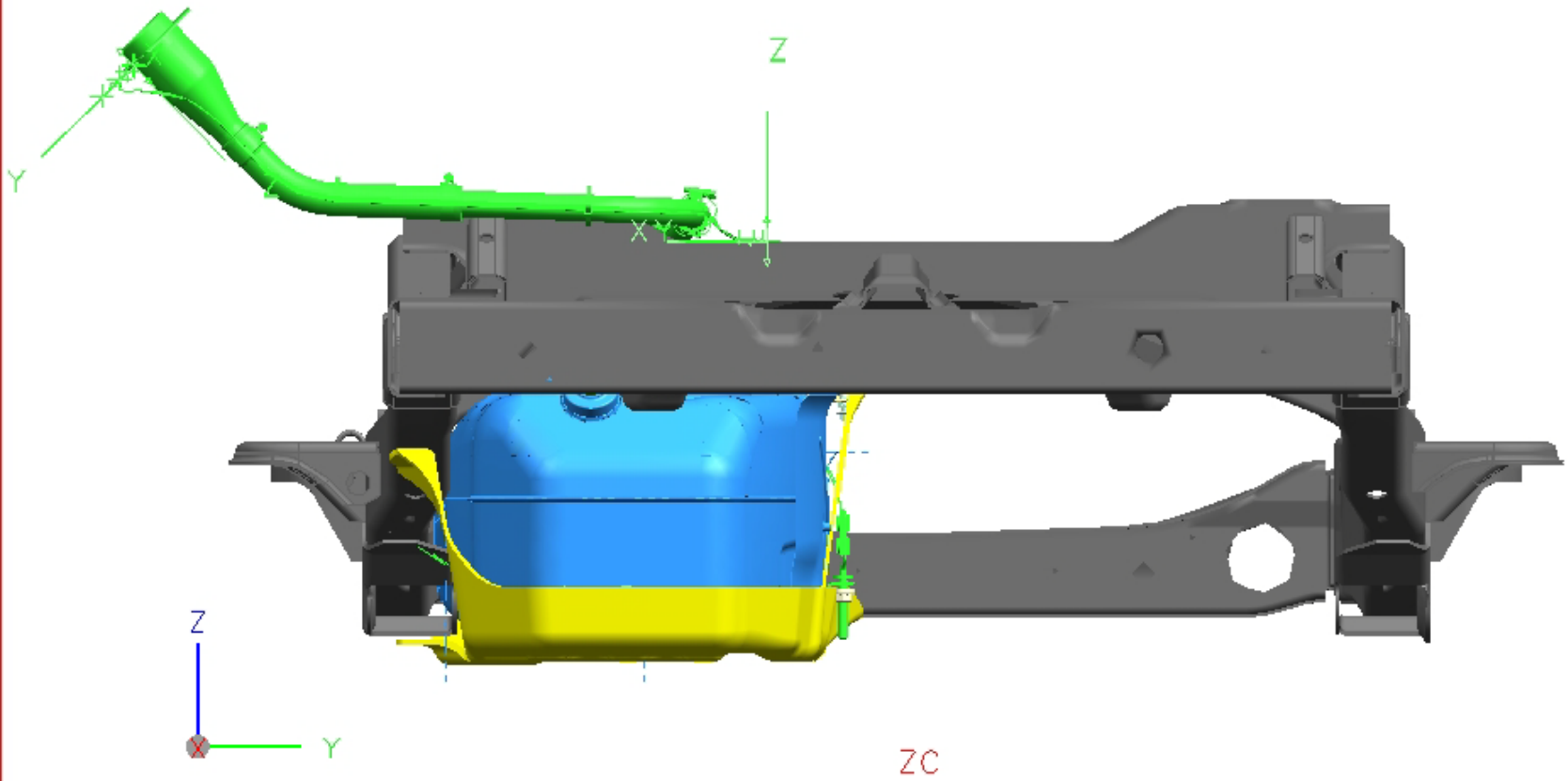

1998 to 2004, 4 door Blazer – Rear View

Optional Polypro shield w/ glass reinf.

NHTSA Peer IR PE10-31_N100337

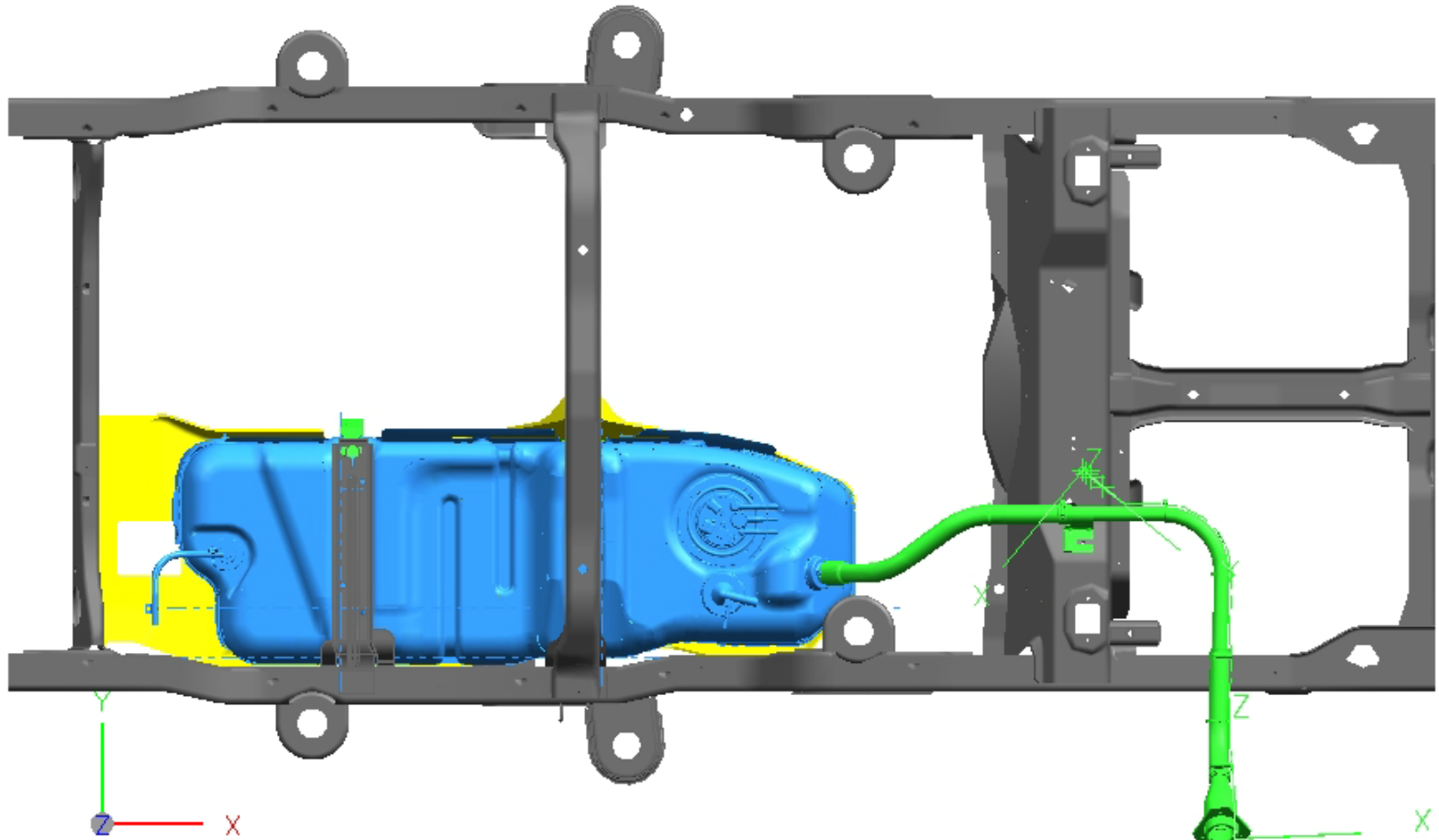

1998 to 2004, 4 door Blazer – Top View

Optional Polypro shield w/ glass reinf.

NHTSA Peer IR PE10-31_N100337

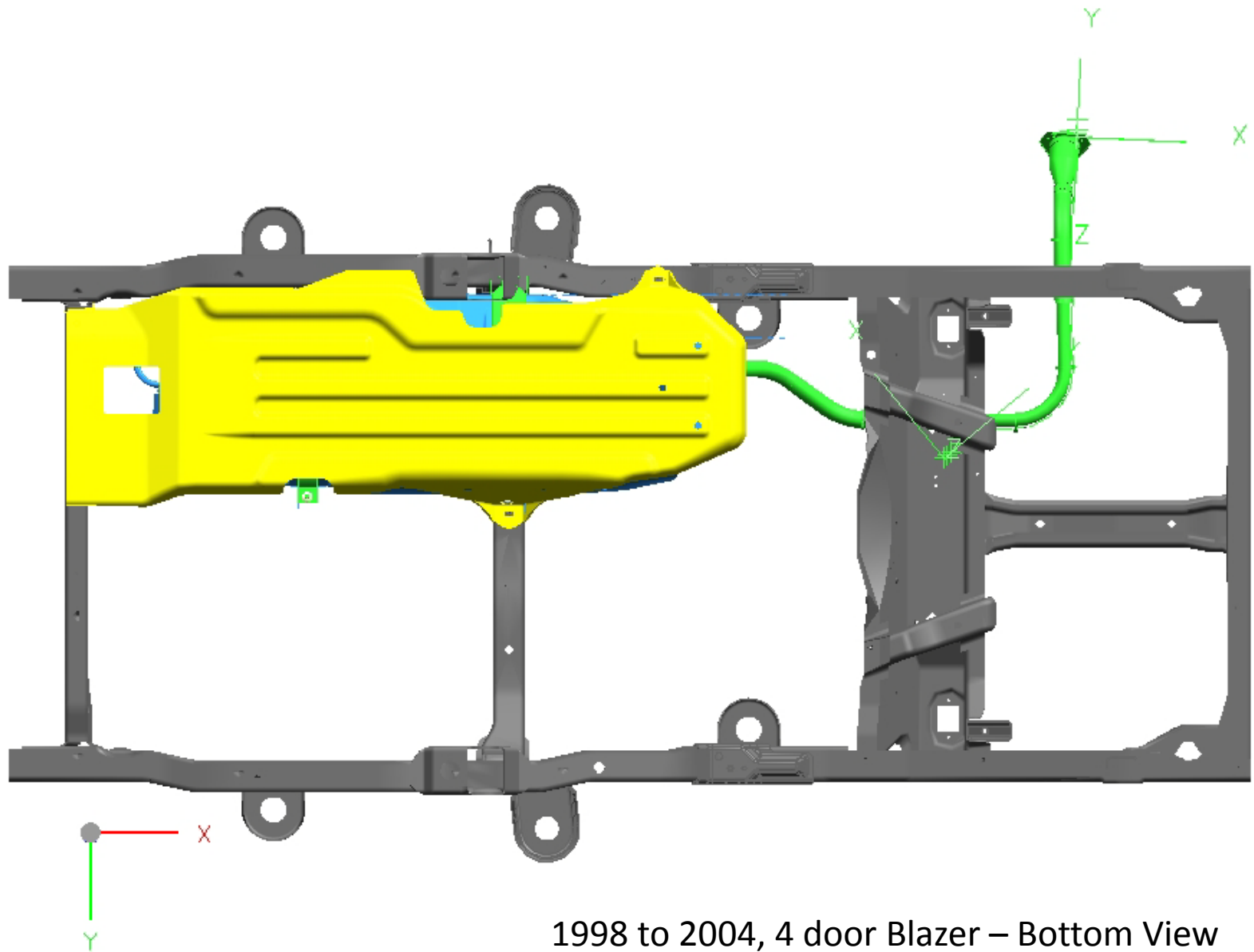

1998 to 2004, 4 door Blazer – Bottom View

Optional Polypro shield w/ glass reinf.