

[Printable View \(361 KB\)](#)

TSB
06-14-10

• **ENGINE/TRANSMISSION DRIVEABILITY ISSUES**

Publication Date: July 5, 2006

FORD: 1999-2003 Windstar
2004-2007 Freestar
MERCURY: 2004-2007 Monterey

This article supersedes TSB **05-23-7** to update the Service Procedure and model years.

ISSUE:

Some 1999-2003 Windstar and 2004-2007 Freestar / Monterey vehicles built prior to 6/22/2006 may exhibit engine / transmission driveability issues due to water entering the powertrain control module (PCM) or transaxle vent. Symptoms may include various diagnostic trouble codes (DTCs), harsh or delayed transmission shifts / engagements, no reverse engagement, engine overheat, engine lean condition causing a misfire (possibly leading to melted electrodes on the spark plugs), and rough idle. The water leakage may be due to the PCM connector cover not seating completely and water leaking down from the cowl panel grille (cowl top vent panel) area.

ACTION:

During normal diagnostic and repair procedures, inspect for evidence of water damage at the PCM, PCM connector, and/or transaxle. If present, inspect the sealing area of the PCM cover, seal the water leak path in the cowl panel grill area, and service the PCM as needed per the following Service Procedure.

SERVICE PROCEDURE

Disconnect the PCM connector. Remove the PCM cover from the studs in the bulkhead. (Figure 1)

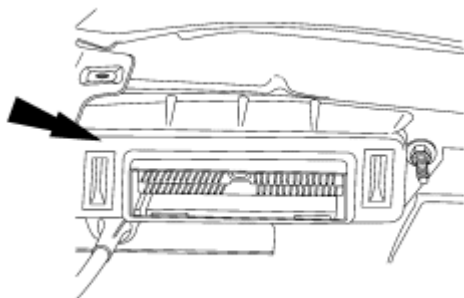

TB-8601-A

Figure 1 - Article 06-14-10

Inspect the body sealant on the bulkhead to ensure it is not protruding out causing the cover not to seal properly in that area. (Figure 2) If sealant is interfering with the PCM cover, remove excess with a sharp tool. Reinstall the PCM cover ensuring the cover seals and is flush with the

bulkhead.

Figure 2 - Article 06-14-10

1. Remove the wiper pivot arm. (Figure 3)
 - a. Release pivot arm nut cover.
 - b. Remove the pivot arm nut.
 - c. Remove the pivot arm.

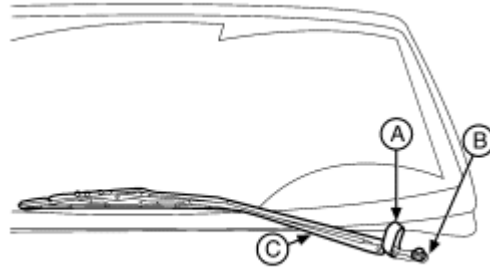

TB-8349-B

Figure 3 - Article 06-14-10

2. Remove the screws. (Figure 4)

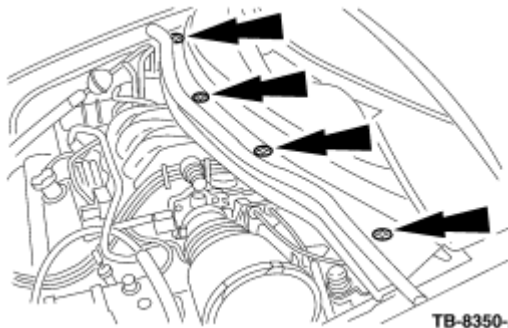

TB-8350-A

Figure 4 - Article 06-14-10

3. Release the clips.
4. Remove the windshield wiper hose.
5. Remove the upper cowl panel grille.
6. Disconnect the electrical connector. (Figure 5)

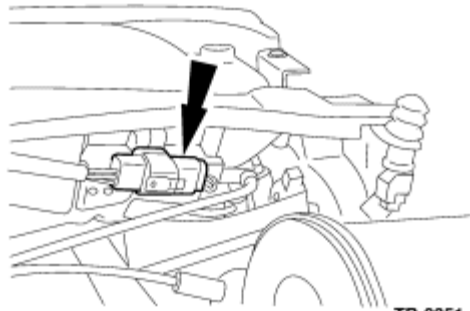

TB-8351-A

Figure 5 - Article 06-14-10

7. Remove the lower cowl panel assembly. (Figure 6)
 - a. Remove the ten (10) bolts.
 - b. Remove the lower cowl panel assembly.

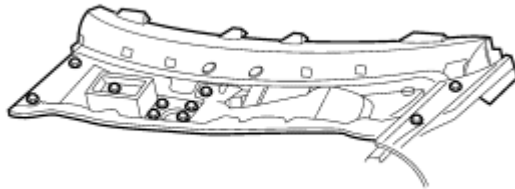

TB-8352-B

Figure 6 - Article 06-14-10

8. Obtain two (2) PVC soft foam adhesive stripes (164-R4901) from the Rotunda Squeak And Rattle Kit (164-R4900).
9. Cut both of the PVC soft foam adhesive stripes in half, lengthwise, so you have four (4) pieces 7/8" x 6" (22 mm x 152 mm). (Figure 7)

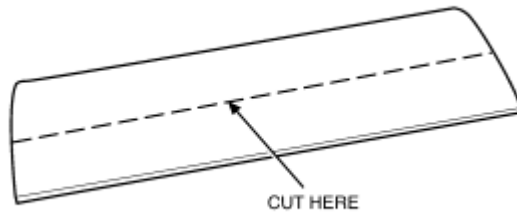

TB-8353-B

Figure 7 - Article 06-14-10

10. Clean the metal body surface under the lower cowl panel, in the area above the transaxle and the area above the PCM.
11. Place two (2) of the cut pieces of the PVC soft foam adhesive stripes on the metal body surface over the transaxle area. The two ends need to touch, do not allow any gap between the two ends. (Figure 8)

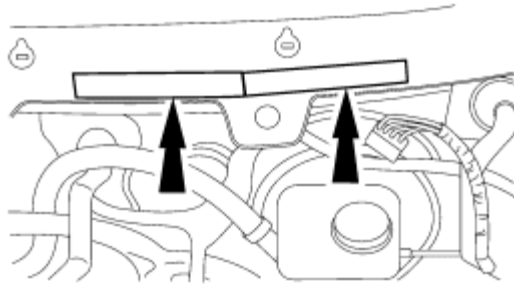

TB-8354-A

Figure 8 - Article 06-14-10

12. Place the other two cut pieces of the PVC soft foam adhesive stripes on the metal body surface over the PCM area. The two ends need to touch, do not allow any gap between the two ends. (Figure 9)

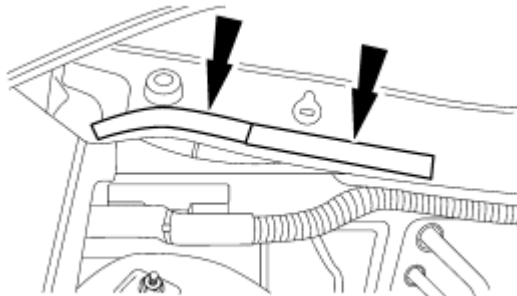

TB-8355-A

Figure 9 - Article 06-14-10

13. Check that the three (3) rubber plugs and five (5) gray plastic clips are fully seated. Add Clear Silicone Rubber around the three (3) rubber plugs and the five (5) gray plastic clips. (Figure 10)

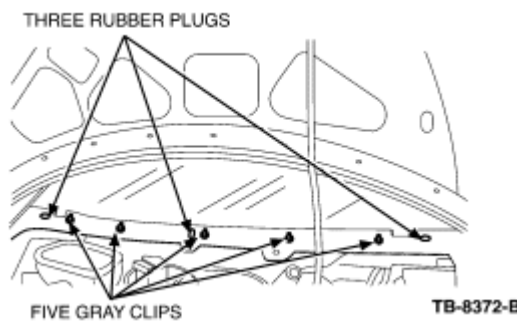

Figure 10 - Article 06-14-10

14. Remove and discard the two rubber plugs on the bottom of the cowl sheet metal. (Figure 11)



TB-8394-A

Figure 11 - Article 06-14-10

15. Install the lower cowl panel and 10 retaining bolts. (Figure 12)

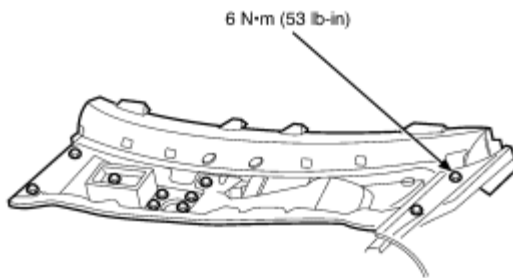

TB-8357-A

Figure 12 - Article 06-14-10

16. Connect the electrical connector. (Figure 13)

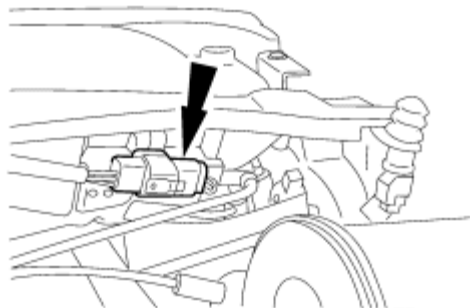

TB-8358-A

Figure 13 - Article 06-14-10

17. Install the upper cowl panel grille.
18. Install the windshield wiper hose.
19. Install four (4) new pushpin screw/rivets to secure the upper cowl to the lower cowl. Add Clear Silicone Rubber to the four (4) pushpin screw/rivets to make a watertight seal around them. (Figure 14)

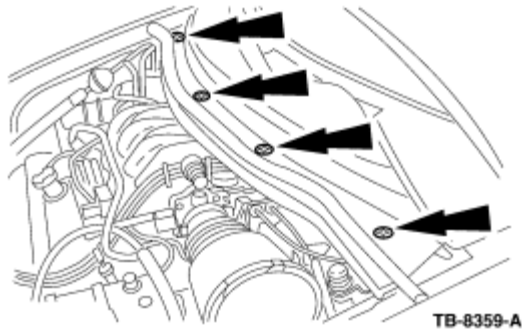

Figure 14 - Article 06-14-10

20. Add Clear Silicone Rubber to the front seam between the upper and lower cowl in the area above the transaxle. (Figure 15)

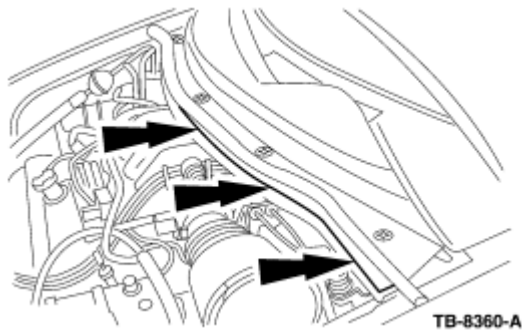

Figure 15 - Article 06-14-10

21. Install wiper pivot arms. (Figure 16)

NOTE: APPLY THREADLOCK TO THE PIVOT ARM NUT.

- 22.

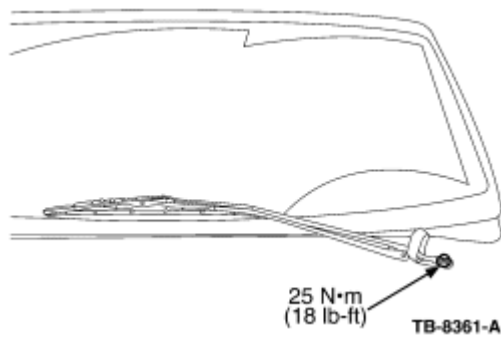

Figure 16 - Article 06-14-10

23. Check the wiper pivot arm adjustment.

PART NUMBER	PART NAME
N806322-S	Pushpin Screw/Rivet (4 per repair)

TA-32	Clear Silicone Rubber
TA-26	Threadlock 262
164-R4901	PVC Soft Foam Adhesive Stripes - Rotunda Part (2 per repair)

WARRANTY STATUS:

Eligible Under Provisions Of New Vehicle Limited Warranty Coverage

OPERATION	DESCRIPTION	TIME
061410A	2004-2007 Freestar/Monterey, 1999-2003 Windstar: Inspect And Seal The Cowl Panel Grill Area (Do Not Use With 17526A, 17566A, 17508A, 17603A)	1.0 Hr.
MT061410	Claim Additional Labor Required As Actual Time Or Use SLTS Operation If Available	Actual Time

DEALER CODING

BASIC PART NO.	CONDITION CODE
7002030	68

NOTE: The information in Technical Service Bulletins is intended for use by trained, professional technicians with the knowledge, tools, and equipment to do the job properly and safely. It informs these technicians of conditions that may occur on some vehicles, or provides information that could assist in proper vehicle service. The procedures should not be performed by "do-it-yourselfers". Do not assume that a condition described affects your car or truck. Contact a Ford, Lincoln, or Mercury dealership to determine whether the Bulletin applies to your vehicle. Warranty Policy and Extended Service Plan documentation determine Warranty and/or Extended Service Plan coverage unless stated otherwise in the TSB article. The information in this Technical Service Bulletin (TSB) was current at the time of printing. Ford Motor Company reserves the right to supercede this information with updates. The most recent information is available through Ford Motor Company's on-line technical resources.

Copyright © 2006 Ford Motor Company