

DIN EN ISO 9227

DIN

ICS 19.040; 87.040

Supersedes
DIN 50021:1988-06 and
DIN EN ISO 7253:2002-04**Corrosion tests in artificial atmospheres –
Salt spray tests (ISO 9227:2006)
English version of DIN EN ISO 9227:2006-10**Korrosionsprüfungen in künstlichen Atmosphären –
Salzsprühnebelprüfungen (ISO 9227:2006)
Englische Fassung DIN EN ISO 9227:2006-10

Document comprises 28 pages

National foreword

This standard has been published in accordance with a decision taken by CEN/TC 139 to adopt, without alteration, International Standard ISO 9227 as a European Standard.

The responsible German body involved in its preparation was the *Normenausschuss Beschichtungsstoffe und Beschichtungen* (Coatings and Coating Materials Standards Committee), Technical Committee NAB 7 *Allgemeine Prüfverfahren für Beschichtungsstoffe und Beschichtungen*.

The DIN Standards corresponding to the International Standards referred to in clause 2 of the EN are as follows:

ISO 1513	DIN EN ISO 1513
ISO 1514	DIN EN ISO 1514
ISO 2808	DIN EN ISO 2808
ISO 3270	DIN EN ISO 23270
ISO 3574	DIN EN 10130
ISO 3613	DIN EN ISO 3613
ISO 3696	DIN ISO 3696
ISO 4527	DIN EN ISO 4527
ISO 4628-1	DIN EN ISO 4628-1
ISO 4628-2	DIN EN ISO 4628-2
ISO 4628-3	DIN EN ISO 4628-3
ISO 4628-4	DIN EN ISO 4628-4
ISO 4628-5	DIN EN ISO 4628-5
ISO 4628-8	DIN EN ISO 4628-8
ISO 10289	DIN EN ISO 10289
ISO 15528	DIN EN ISO 15528
ISO 17872	E DIN EN ISO 17872

Amendments

This standard differs from 50021:1988-06 and DIN EN ISO 7253:2002-04 as follows:

The standards have been harmonized and the scope has been combined.

Previous editions

DIN 50021:1970-04, 1975-05, 1988-06

DIN 53167: 1972-08, 1985-12

DIN EN ISO 7253: 2002-04

National Annex NA (informative)

Bibliography

- DIN EN 10130, *Cold rolled low carbon steel flat products for cold forming — Technical delivery conditions*
- DIN EN 23270, *Paints, varnishes and their raw materials — Temperatures and humidities for conditioning and testing*
- DIN EN ISO 1513, *Paints and varnishes — Examination and preparation of samples for testing*
- DIN EN ISO 1514, *Paints and varnishes — Standard panels for testing*
- DIN EN ISO 2808, *Paints and varnishes — Determination of film thickness*
- DIN EN ISO 3613, *Chromate conversion coatings on zinc, cadmium, aluminium-zinc alloys and zinc-aluminium alloys — Test methods*
- DIN EN ISO 4527, *Metallic coatings — Autocatalytic (electroless) nickel-phosphorus alloy coatings — Specifications and test methods*
- DIN EN ISO 4628-1, *Paints and varnishes — Evaluation of degradation of coatings — Designation of quantity and size of defects, and of intensity of uniform changes in appearance — Part 1: General introduction and designation system*
- DIN EN ISO 4628-2, *Paints and varnishes — Evaluation of degradation of coatings — Designation of quantity and size of defects, and of intensity of uniform changes in appearance — Part 2: Assessment of degree of blistering*
- DIN EN ISO 4628-3, *Paints and varnishes — Evaluation of degradation of coatings — Designation of quantity and size of defects, and of intensity of uniform changes in appearance — Part 3: Assessment of degree of rusting*
- DIN EN ISO 4628-4, *Paints and varnishes — Evaluation of degradation of coatings — Designation of quantity and size of defects, and of intensity of uniform changes in appearance — Part 4: Assessment of degree of cracking*
- DIN EN ISO 4628-5, *Paints and varnishes — Evaluation of degradation of coatings — Designation of quantity and size of defects, and of intensity of uniform changes in appearance — Part 5: Assessment of degree of flaking*
- DIN EN ISO 4628-8, *Paints and varnishes — Evaluation of degradation of coatings — Designation of quantity and size of defects, and of intensity of uniform changes in appearance — Part 8: Assessment of degree of delamination and corrosion around a scribe*
- DIN EN ISO 10289, *Methods for corrosion testing of metallic and other inorganic coatings on metallic substrates — Rating of test specimens and manufactured articles subjected to corrosion tests*

DIN EN ISO 9227:2006-10

DIN EN ISO 15528, *Paints, varnishes and raw materials for paints and varnishes — Sampling*

E DIN EN ISO 17872*), *Paints and varnishes — Guidelines for the introduction of scribe marks through coatings on metallic panels for corrosion testing*

DIN ISO 3696, *Water for analytical laboratory use — Specification and test methods*

*) At draft stage.

English Version

Corrosion tests in artificial atmospheres - Salt spray tests
(ISO 9227:2006)

Essais de corrosion en atmosphères artificielles - Essais
aux brouillards salins (ISO 9227:2006)

Korrosionsprüfungen in künstlichen Atmosphären -
Salzprühnebelprüfungen (ISO 9227:2006)

This European Standard was approved by CEN on 7 July 2006.

CEN members are bound to comply with the CEN/CENELEC Internal Regulations which stipulate the conditions for giving this European Standard the status of a national standard without any alteration. Up-to-date lists and bibliographical references concerning such national standards may be obtained on application to the Central Secretariat or to any CEN member.

This European Standard exists in three official versions (English, French, German). A version in any other language made by translation under the responsibility of a CEN member into its own language and notified to the Central Secretariat has the same status as the official versions.

CEN members are the national standards bodies of Austria, Belgium, Cyprus, Czech Republic, Denmark, Estonia, Finland, France, Germany, Greece, Hungary, Iceland, Ireland, Italy, Latvia, Lithuania, Luxembourg, Malta, Netherlands, Norway, Poland, Portugal, Romania, Slovakia, Slovenia, Spain, Sweden, Switzerland and United Kingdom.



EUROPEAN COMMITTEE FOR STANDARDIZATION
COMITÉ EUROPÉEN DE NORMALISATION
EUROPÄISCHES KOMITEE FÜR NORMUNG

Management Centre: rue de Stassart, 36 B-1050 Brussels

Foreword

This document (EN ISO 9227:2006) has been prepared by Technical Committee ISO/TC 35 "Paints and varnishes" in collaboration with Technical Committee CEN/TC 139 "Paints and varnishes", the secretariat of which is held by DIN.

This European Standard shall be given the status of a national standard, either by publication of an identical text or by endorsement, at the latest by January 2007, and conflicting national standards shall be withdrawn at the latest by January 2007.

This document supersedes EN ISO 7253:2001.

According to the CEN/CENELEC Internal Regulations, the national standards organizations of the following countries are bound to implement this European Standard: Austria, Belgium, Cyprus, Czech Republic, Denmark, Estonia, Finland, France, Germany, Greece, Hungary, Iceland, Ireland, Italy, Latvia, Lithuania, Luxembourg, Malta, Netherlands, Norway, Poland, Portugal, Romania, Slovakia, Slovenia, Spain, Sweden, Switzerland and United Kingdom.

Endorsement notice

The text of ISO 9227:2006 has been approved by CEN as EN ISO 9227:2006 without any modifications.

Contents

Page

Foreword	2
Introduction.....	4
1 Scope.....	5
2 Normative references.....	6
3 Test solutions	6
3.1 Preparation of the sodium chloride solution.....	6
3.2 pH adjustment.....	6
3.3 Filtration	7
4 Apparatus.....	7
4.1 Component protection.....	7
4.2 Spray cabinet.....	7
4.3 Heater and temperature control.....	7
4.4 Spraying device.....	8
4.5 Collecting devices.....	8
4.6 Re-use.....	9
5 Method of evaluation of the corrosivity of the cabinet.....	9
5.1 General	9
5.2 NSS test.....	9
5.3 AASS test	10
5.4 CASS test	11
6 Test specimens.....	13
7 Arrangement of the test specimens	13
8 Operating conditions	14
9 Duration of tests	14
10 Treatment of specimens after test.....	15
11 Evaluation of results	15
12 Test report.....	15
Annex A (informative) Schematic diagram of one possible design of spray cabinet with means for treating fog exhaust and drain.....	17
Annex B (informative) Complementary method for evaluation of the corrosivity of the cabinet by use of zinc reference specimens	19
Annex C (normative) Preparation of panels with organic coatings for testing.....	21
Annex D (normative) Required supplementary information for testing test panels with organic coatings.....	22
Bibliography.....	23

Introduction

There is seldom a direct relation between resistance to the action of salt spray and resistance to corrosion in other media, because several factors influencing the progress of corrosion, such as the formation of protective films, vary greatly with the conditions encountered. Therefore, the test results should not be regarded as a direct guide to the corrosion resistance of the tested metallic materials, in all environments where these materials may be used. Also, the performance of different materials, during the test should not be taken as a direct guide to the corrosion resistance of these materials in service.

Nevertheless, the method described gives a means of checking that the comparative quality of a metallic material, with or without corrosion protection, is maintained.

Salt spray tests are generally suitable as corrosion protection tests for rapid analysis for discontinuities, pores and damage in organic and inorganic coatings. In addition, for quality control purposes, comparison can be made between specimens coated with the same coating. As comparative tests, however, salt spray tests are only suitable if the coatings are sufficiently similar in nature.

It is often not possible to use results gained from salt spray testing as a comparative guide to the long-term behaviour of different coating systems, as the corrosion stress during these tests differs significantly from the corrosion stresses encountered in practice.

1 Scope

This International Standard specifies the apparatus, the reagents and the procedure to be used in conducting the neutral salt spray (NSS), acetic acid salt spray (AASS) and copper-accelerated acetic acid salt spray (CASS) tests for assessment of the corrosion resistance of metallic materials, with or without permanent or temporary corrosion protection.

It also describes the method employed to evaluate the corrosivity of the test-cabinet environment.

It does not specify the dimensions of test specimens, the exposure period to be used for a particular product, or the interpretation of results. Such details are provided in the appropriate product specifications.

The salt spray tests are particularly useful for detecting discontinuities, such as pores and other defects in certain metallic, organic, anodic oxide and conversion coatings.

The neutral salt spray test applies to:

- metals and their alloys;
- metallic coatings (anodic and cathodic);
- conversion coatings;
- anodic oxide coatings;
- organic coatings on metallic materials.

The acetic acid salt spray test is especially useful for testing decorative coatings of copper + nickel + chromium, or nickel + chromium. It has also been found suitable for testing anodic coatings on aluminum.

The copper-accelerated acetic acid salt spray test is useful for testing decorative coatings of copper + nickel + chromium, or nickel + chromium. It has also been found suitable for testing anodic coatings on aluminum.

The salt spray methods are all suitable for checking that the comparative quality of a metallic material, with or without corrosion protection, is maintained. They are not intended to be used for comparative testing, to rank different materials relative to each other with respect to corrosion resistance.

2 Normative references

The following referenced documents are indispensable for the application of this document. For dated references, only the edition cited applies. For undated references, the latest edition of the referenced document (including any amendments) applies.

ISO 1514:2004, *Paints and varnishes — Standard panels for testing*

ISO 2808:—¹⁾, *Paints and varnishes — Determination of film thickness*

ISO 3574:1999, *Cold-reduced carbon steel sheet of commercial and drawing qualities*

ISO 8407:—²⁾, *Corrosion of metals and alloys — Removal of corrosion products from corrosion test specimens*

ISO 17872:—³⁾, *Paints and varnishes — Guidelines for the introduction of scribe marks through coatings on metallic panels for corrosion testing*

3 Test solutions

3.1 Preparation of the sodium chloride solution

Dissolve a sufficient mass of sodium chloride in distilled or deionized water with a conductivity not higher than 20 $\mu\text{S}/\text{cm}$ at $25\text{ }^\circ\text{C} \pm 2\text{ }^\circ\text{C}$ to produce a concentration of $50\text{ g/l} \pm 5\text{ g/l}$. The sodium chloride concentration of the sprayed solution collected shall be $50\text{ g/l} \pm 5\text{ g/l}$. The specific gravity range for a $50\text{ g/l} \pm 5\text{ g/l}$ solution is 1,029 to 1,036 at $25\text{ }^\circ\text{C}$.

The sodium chloride shall contain less than 0,001 % mass fraction of copper and less than 0,001 % mass fraction of nickel, as determined by atomic absorption spectrophotometry or another analytical method of similar sensitivity. It shall not contain more than 0,1 % of a mass fraction of sodium iodide, or more than 0,5 % of a mass fraction of total impurities calculated for dry salt.

NOTE If the pH of prepared solution at $25\text{ }^\circ\text{C} \pm 2\text{ }^\circ\text{C}$ is outside the range 6,0 to 7,0, investigate the presence of undesirable impurities in the salt and/or the water.

3.2 pH adjustment

3.2.1 pH of the salt solution

Adjust the pH of the salt solution to the desired value on the basis of the pH of the sprayed solution collected.

3.2.2 NSS test

Adjust the pH of the salt solution (3.1) so that the pH of the sprayed solution collected within the test cabinet (4.2) is 6,5 to 7,2 at $25\text{ }^\circ\text{C} \pm 2\text{ }^\circ\text{C}$. Check the pH using electrometric measurement or in routine checks, with a short-range pH paper, which can be read in increments or 0,3 pH units or less. Make any necessary correction by adding hydrochloric acid, sodium hydroxide or sodium bicarbonate solution of analytical grade.

1) To be published. (Revision of ISO 2808:1997)

2) To be published. (Revision of ISO 8407:1991)

3) To be published.

Possible changes in pH may result from loss of carbon dioxide from the solution when it is sprayed. Such changes may be avoided by reducing the carbon dioxide content of the solution by, for example, heating it to a temperature above 35 °C before it is placed in the apparatus, or by making the solution using freshly boiled water.

3.2.3 AASS test

Add a sufficient amount of glacial acetic acid to the salt solution (3.1) to ensure that the pH of samples of sprayed solution collected in the test cabinet (4.2) is between 3,1 and 3,3. If the pH of the solution initially prepared is 3,0 to 3,1, the pH of the sprayed solution is likely to be within the specified limits. Check the pH using electrometric measurement at $25\text{ °C} \pm 2\text{ °C}$, or, in routine checks, with a short-range pH paper which can be read in increments of 0,1 pH units or less. Make any necessary correction by adding glacial acetic acid or sodium hydroxide of analytical grade.

3.2.4 CASS test

Dissolve a sufficient mass of copper(II) chloride dihydrate ($\text{CuCl}_2 \cdot 2\text{H}_2\text{O}$) in the salt solution (3.1) to produce a concentration of $0,26\text{ g/l} \pm 0,02\text{ g/l}$ [equivalent to $(0,205 \pm 0,015)\text{ g}$ of CuCl_2 per litre].

Adjust the pH using the procedures described in 3.2.2.

3.3 Filtration

If necessary, filter the solution before placing it in the reservoir of the apparatus, to remove any solid matter which might block the apertures of the spraying device.

4 Apparatus

4.1 Component protection

All components in contact with the spray or the test solution shall be made of, or lined with, materials resistant to corrosion by the sprayed solution and which do not influence the corrosivity of the sprayed test solutions.

4.2 Spray cabinet

The cabinet shall have a capacity of not less than $0,4\text{ m}^3$ since, with smaller volumes, difficulties have been experienced in ensuring an even distribution of spray. For large-capacity cabinets, it is necessary to ensure that the conditions of homogeneity and distribution of the spray are met. The upper parts of the cabinet shall be designed so that drops of sprayed solution formed on its surface do not fall on the specimens being tested.

The size and shape of the cabinet shall be such that the collection rate of solution in the cabinet is within the limits specified in Table 2, measured as specified in 8.3.

It is preferred that the apparatus has a means to properly treat the fog after the test, prior to releasing it from the building for environmental conservation, and also to drain water prior to discharging it to the drainage system.

NOTE A schematic diagram of one possible design of spray cabinet is shown in Annex A.

4.3 Heater and temperature control

An appropriate system maintains the cabinet and its contents at the specified temperature (see Table 2). The temperature shall be measured at least 100 mm from the walls.

4.4 Spraying device

The device for spraying the salt solution comprises a supply of clean air, of controlled pressure and humidity, a reservoir to contain the solution to be sprayed, and one or more atomizers.

The compressed air supplied to the atomizers shall be passed through a filter to remove all traces of oil or solid matter, and the atomizing pressure shall be at an overpressure of 70 kPa ⁴⁾ to 170 kPa.

NOTE Atomizing nozzles may have a “critical pressure” at which an abnormal increase in the corrosiveness of the salt spray occurs. If the “critical pressure” of a nozzle has not been established with certainty, control of fluctuations in the air pressure within ± 0,7 kPa, by installation of a suitable pressure regulator valve, minimizes the possibility that the nozzle will be operated at its “critical pressure”.

In order to prevent evaporation of water from the sprayed droplets, the air shall be humidified before entering the atomizer, by passage through a saturation tower containing hot distilled water or deionized water at a temperature 10 °C above that of the cabinet. The appropriate temperature depends on the pressure used and on the type of atomizer nozzle and shall be adjusted so that the rate of collection of spray in the cabinet, and the concentration of the collected spray, are kept within the specified limits (see 8.3). In Table 1, guiding values for the hot water temperature in the saturation tower at different pressures are given. The level of the water shall be maintained automatically to ensure adequate humidification.

Table 1 — Guiding values for the temperature of the hot water in the saturation tower

Atomizing over-pressure	Guiding values for temperature, °C, of the hot water in the saturation tower when performing the different salt spray tests	
	kPa	Neutral salt spray (NSS) and acetic acid salt spray (AASS)
70	45	61
84	46	63
98	48	64
112	49	66
126	50	67
140	52	69

The atomizers shall be made of inert material. Baffles may be used to prevent direct impact of spray on the test specimens, and the use of adjustable baffles is helpful in obtaining uniform distribution of the spray within the cabinet. For this purpose, a dispersion tower equipped with an atomizer may also be helpful. The level of the salt solution in the salt reservoir shall be maintained automatically to ensure uniform spray delivery throughout the test.

4.5 Collecting devices

At least two suitable collecting devices shall be available, consisting of funnels made of chemically inert material, with the stems inserted into graduated cylinders or other similar containers. Suitable funnels have a diameter of 100 mm, which corresponds to a collecting area of approximately 80 cm². The collecting devices shall be placed in the zone of the cabinet where the test specimens are placed, one close to an inlet of spray and one remote from an inlet. They shall be placed so that only mist, and not liquid falling from specimens or from parts of the cabinet, is collected.

4) 1 kPa = 1 kN/m² = 0,01 atm = 0,01 bar = 0,145 psi.

4.6 Re-use

If the cabinet has been used once for an AASS or CASS test, or has been used for any other purpose with a solution differing from that specified for the NSS test, it shall not be used for the NSS test.

It is nearly impossible to clean a cabinet that was once used for AASS or CASS testing so that it can be used for a NSS test. However, in this circumstance, the equipment shall be thoroughly cleaned, and then checked by the method described in Clause 5; particularly ensuring that the pH of the collected solution is correct throughout the entire spraying period. After this procedure, the specimens to be tested are placed in the cabinet.

5 Method of evaluation of the corrosivity of the cabinet

5.1 General

To check the reproducibility and repeatability of the test results for one piece of apparatus, or for similar items of apparatus in different laboratories, it is necessary to verify the apparatus at regular intervals as described in 5.2 to 5.4.

NOTE During permanent operation, a reasonable time period between two checks of the corrosivity of the apparatus is generally considered to be 3 months.

To determine the corrosivity of the tests, reference-metal specimens of steel shall be used.

As a complement to reference-metal specimens made of steel, high-purity zinc reference-metal specimens may also be exposed in the tests, to determine the corrosivity against this metal as described in Annex B.

5.2 NSS test

5.2.1 Reference specimens

To verify the apparatus, use four or six reference specimens of $1\text{ mm} \pm 0,2\text{ mm}$ thickness and $150\text{ mm} \times 70\text{ mm}$, of CR4 grade steel in accordance with ISO 3574, with an essentially faultless surface ⁵⁾, and a matt finish (arithmetically mean deviation of the profile $R_a = 0,8\text{ }\mu\text{m} \pm 0,3\text{ }\mu\text{m}$). Cut these reference specimens from cold-rolled plates or strips.

Clean the reference specimens carefully, immediately before testing. Besides the specification given in 6.2 and 6.3, cleaning shall eliminate all those traces (dirt, oil or other foreign matter), which could influence the test results.

Thoroughly clean the reference specimens with an appropriate organic solvent (such as a hydrocarbon with a boiling point between $60\text{ }^\circ\text{C}$ and $120\text{ }^\circ\text{C}$) using a clean soft brush or an ultrasonic cleaning device. Carry out the cleaning in a vessel full of solvent. After cleaning, rinse the reference specimens with fresh solvent and then dry them.

Determine the mass of the reference specimens to $\pm 1\text{ mg}$. Protect one face of the reference specimens with a removable coating, for example an adhesive plastic film. The edges of the reference test specimens may be protected by the adhesive tape as well.

5) "Essentially faultless" means free from pores, marks, scratches and any light colouration.

5.2.2 Arrangement of the reference specimens

Position four steel reference specimens in four quadrants (if six specimens are available, place them in six different positions including four quadrants) in the zone of the cabinet where the test specimens are placed, with the unprotected face upwards, and at an angle of $20^\circ \pm 5^\circ$ from the vertical.

The support for the reference specimens shall be made of, or coated with, inert materials such as plastics. The lower edge of the reference specimens shall be level with the top of the salt spray collector. The test duration shall be 48 h.

Test specimens of types different from the reference specimens shall not be placed in the test cabinet during the verification procedure.

5.2.3 Determination of mass loss (mass per area)

At the end of the test, immediately take the reference specimens out of the test cabinet and remove the protective coating. Remove the corrosion products by mechanical and chemical cleaning as described in ISO 8407. Use, for chemical cleaning, a solution with a mass fraction of 20 % of diammonium citrate $[(\text{NH}_4)_2\text{HC}_6\text{H}_5\text{O}_7]$ (recognized analytical grade) in water for 10 min at 23 °C.

After each stripping, thoroughly clean the reference specimens at ambient temperature with water, then with ethanol, followed by drying.

Weigh the reference specimens to the nearest 1 mg. Divide the determined mass loss by the area of the exposed surface area of the reference specimen, to assess the metal mass loss per square metre of the reference specimen.

It is recommended to use freshly prepared solution during every procedure for removal of corrosion products.

NOTE The corrosion products may also be removed by chemical cleaning as described in ISO 8407, and by using a solution with a volume fraction of 50 % of hydrochloric acid ($\rho_{20} = 1,18 \text{ g/ml}$), of recognized analytical grade, in water, the latter also containing 3,5 g/l of hexamethylene tetramine as a corrosion inhibitor.

5.2.4 Checking of NSS apparatus operation

The operation of the test apparatus is satisfactory if the mass loss of each reference specimen is $70 \pm 20 \text{ g/m}^2$ for 48 h operation using steel reference specimens ⁶⁾.

5.3 AASS test

5.3.1 Reference specimens

To verify the apparatus, use four or six reference specimens of $1 \text{ mm} \pm 0,2 \text{ mm}$ thickness and $150 \text{ mm} \times 70 \text{ mm}$, of CR4 grade steel in accordance with ISO 3574, with an essentially faultless surface⁷⁾, and a matt finish (arithmetically mean deviation of the profile $Ra = 0,8 \mu\text{m} \pm 0,3 \mu\text{m}$). Cut these reference specimens from cold-rolled plates or strips.

Clean the reference specimens carefully, immediately before testing. Besides the specification given in 6.2 and 6.3, cleaning shall eliminate all those traces (dirt, oil or other foreign matter) which could influence the test results.

Thoroughly clean the reference specimens with an appropriate organic solvent (such as a hydrocarbon with a boiling point between 60 °C and 120 °C) using a clean soft brush or an ultrasonic cleaning device. Carry out

6) See Bibliography, Reference [21].

7) "Essentially faultless" means free from pores, marks, scratches and any light colouration.

the cleaning in a vessel full of solvent. After cleaning, rinse the reference specimens with fresh solvent, and then dry them.

Determine the mass of the reference specimens to ± 1 mg. Protect one face of the reference specimens with a removable coating, for example an adhesive plastic film. The edges of the reference test specimens may be protected by the adhesive tape as well

5.3.2 Arrangement of the reference specimens

Position four steel reference specimens in four quadrants (if six specimens are available, place them in six different positions including four quadrants) in the zone of the cabinet where the test specimens are placed, with the unprotected face upwards, and at an angle of $20^\circ \pm 5^\circ$ from the vertical.

The support for the reference specimens shall be made of, or coated with, inert materials such as plastics. The lower edge of the reference specimens shall be level with the top of the salt spray collector. The test duration shall be 24 h.

Test specimens of types different from the reference specimens shall not be placed in the test cabinet during the verification procedure.

5.3.3 Determination of mass loss (mass per area)

At the end of the test, immediately take the reference specimens out of the test cabinet and remove the protective coating. Remove the corrosion products by mechanical and chemical cleaning as described in ISO 8407. Use, for chemical cleaning, a solution with a mass fraction of 20 % of diammonium citrate $[(\text{NH}_4)_2\text{HC}_6\text{H}_5\text{O}_7]$ (recognized analytical grade) in water for 10 min at 23 °C.

After each stripping, thoroughly clean the reference specimens at ambient temperature with water, then with ethanol, followed by drying.

Weigh the reference specimens to the nearest 1 mg. Divide the determined mass loss by the area of the exposed surface area of the reference specimen, to assess the metal mass loss per square metre of the reference specimen.

It is recommended to use freshly prepared solution during every procedure for removal of corrosion products.

NOTE The corrosion products may also be removed by chemical cleaning as described in ISO 8407 and by using a solution with a volume fraction of 50 % of hydrochloric acid ($\rho_{20} = 1,18$ g/ml), of recognized analytical grade, in water, the latter also containing 3,5 g per litre of hexamethylene tetramine as a corrosion inhibitor.

5.3.4 Checking of AASS apparatus operation

The operation of the test apparatus is satisfactory if the mass loss of each reference specimen is 40 ± 10 g/m² for 24 h operation using steel reference specimens ⁸⁾.

5.4 CASS test

5.4.1 Reference specimens

To verify the apparatus, use four or six reference specimens of $1 \text{ mm} \pm 0,2 \text{ mm}$ thickness and $150 \text{ mm} \times 70 \text{ mm}$, of CR4 grade steel in accordance with ISO 3574, with an essentially faultless surface ⁹⁾, and a matt finish (arithmetically mean deviation of the profile $R_a = 0,8 \mu\text{m} \pm 0,3 \mu\text{m}$). Cut these reference specimens from cold-rolled plates or strips.

8) See Bibliography, Reference [21].

9) "Essentially faultless" means free from pores, marks, scratches and any light colouration.

Clean the reference specimens carefully, immediately before testing. Besides the specification given in 6.2 and 6.3, cleaning shall eliminate all those traces (dirt, oil or other foreign matter), which could influence the test results.

Thoroughly clean the reference specimens with an appropriate organic solvent (such as a hydrocarbon with a boiling point between 60 °C and 120 °C) using a clean soft brush or an ultrasonic cleaning device. Carry out the cleaning in a vessel full of solvent. After cleaning, rinse the reference specimens with fresh solvent, then dry them.

Determine the mass of the reference specimens to ± 1 mg. Protect one face of the reference specimens with a removable coating, for example an adhesive plastic film. The edges of the reference test specimens may be protected by the adhesive tape as well.

5.4.2 Arrangement of the reference specimens

Position four steel reference specimens in four quadrants (if six specimens are available, place them in six different positions including four quadrants) in the zone of the cabinet where the test specimens are placed, with the unprotected face upwards, and at an angle of $20^\circ \pm 5^\circ$ from the vertical.

The support for the reference specimens shall be made of, or coated with, inert materials such as plastics. The lower edge of the reference specimens shall be level with the top of the salt spray collector. The test duration is 24 h.

Test specimens of types different from the reference specimens shall not be placed in the test chamber during the verification procedure.

5.4.3 Determination of mass loss (mass per area)

At the end of the test, immediately take the reference specimens out of the test cabinet and remove the protective coating. Remove the corrosion products by mechanical and chemical cleaning as described in ISO 8407. Use, for chemical cleaning, a solution with a mass fraction of 20 % of diammonium citrate $[(\text{NH}_4)_2\text{HC}_6\text{H}_5\text{O}_7]$ (recognized analytical grade) in water for 10 min at 23 °C.

After each stripping, thoroughly clean the reference specimens at ambient temperature with water, then with ethanol, followed by drying.

Weigh the reference specimens to the nearest 1 mg. Divide the determined mass loss by the area of the exposed surface area of the reference specimen, to assess the metal mass loss per square metre of the reference specimen.

It is recommended to use freshly prepared solution during every procedure for removal of corrosion products.

NOTE The corrosion products may also be removed by chemical cleaning as described in ISO 8407, and by using a solution with a volume fraction of 50 % of hydrochloric acid ($\rho_{20} = 1,18$ g/ml), of recognized analytical grade, in water, the latter also containing 3,5 g per litre of hexamethylene tetramine as a corrosion inhibitor.

5.4.4 Checking of CASS apparatus operation

The operation of the test apparatus is satisfactory if the mass loss of each reference specimen is 55 ± 15 g/m² for 24 h operation using steel reference specimens ¹⁰⁾.

10) See Bibliography, Reference [21].

6 Test specimens

6.1 The number and type of test specimens, their shape and their dimensions shall be selected according to the specification for the material or product being tested. When not so specified, these details shall be mutually agreed between the interested parties. Unless otherwise specified or agreed, test panels with organic coating to be tested shall be made from burnished steel complying with ISO 1514, and of approximate dimensions 150 mm × 100 mm × 1 mm. Annex C describes how test panels with organic coatings are to be prepared for testing. Annex D gives supplementary information needed for testing of test panels with organic coatings.

6.2 The test specimens shall be thoroughly cleaned before testing, if not otherwise specified. The cleaning method employed shall depend on the nature of the material, its surface and the contaminants, and shall not include the use of any abrasives or solvents which may attack the surface of the specimens.

Care shall be taken that specimens are not recontaminated after cleaning by careless handling.

6.3 If the test specimens are cut from a larger coated article, cutting shall be carried out in such a way that the coating is not damaged in the area adjacent to the cut. Unless otherwise specified, the cut edges shall be adequately protected by coating them with a suitable material, stable under the conditions of the test, such as paint, wax or adhesive tape.

7 Arrangement of the test specimens

7.1 The test specimens shall be placed in the cabinet so that they are not in the direct line of travel of the spray from the atomizer.

7.2 The angle at which the surface of the test specimen is exposed in the cabinet is very important. The specimen shall, in principle, be flat and placed in the cabinet facing upwards at an angle as close as possible to 20° to the vertical. This angle shall, in all cases, be within the limits 15° to 25°. In the case of irregular surfaces, for example entire components, these limits shall be adhered to as closely as possible.

7.3 The test specimens shall be arranged so that they do not come into contact with the cabinet and so that surfaces to be tested are exposed to free circulation of spray. The specimens may be placed at different levels within the cabinet, as long as the solution does not drip from specimens or their supports at one level onto other specimens placed below. However, for a new examination or for tests with a total duration exceeding 96 h, location permutation of specimens is permitted ¹¹⁾.

7.4 The supports for the test specimens shall be made of inert non-metallic material. If it is necessary to suspend specimens, the material used shall not be metallic but shall be synthetic fibre, cotton thread or other inert insulating material.

11) In this case, the number and frequency of the permutations are left up to the operator and shall be indicated in the test report.

8 Operating conditions

8.1 Operating conditions are summarized in Table 2.

Table 2 — Operating conditions

Test method Item	Neutral salt spray (NSS)	Acetic acid salt spray (AASS)	Copper-accelerated acetic acid salt spray (CASS)
Temperature	35 °C ± 2 °C	35 °C ± 2 °C	50 °C ± 2 °C
Average collection rate for a horizontal collecting area of 80 cm ²	1,5 ml/h ± 0,5 ml/h		
Concentration of sodium chloride (collected solution)	50 g/l ± 5 g/l		
pH (collected solution)	6,5 to 7,2	3,1 to 3,3	3,1 to 3,3

8.2 Prior to a test, first check the collection rate and other test conditions in the test chamber when it is empty or completely filled with dummy specimens. After it has been confirmed that the test conditions are within a specified range, fill the test chamber with test specimens and start the test.

8.3 The solution collected in each of the collecting devices (4.5) shall have a sodium chloride concentration and a pH value within the ranges given in Table 2.

The average rate of collection of solution in each device shall be measured over a minimum period of 24 h of continuous spraying.

8.4 The test solution which has been sprayed shall not be re-used.

9 Duration of tests

9.1 The period of test shall be as designated by the specification covering the material or product being tested. When not specified, this period shall be agreed upon by the interested parties.

Recommended periods of exposure are 2 h, 6 h, 24 h, 48 h, 96 h, 168 h, 240 h, 480 h, 720 h and 1 000 h.

9.2 Spraying shall not be interrupted during the prescribed test period. The cabinet shall be opened only for brief visual inspections of the test specimens in position and for replenishing the salt solution in the reservoir, if such replenishment cannot be carried out from outside the cabinet.

9.3 If the end-point of the test depends on the appearance of the first sign of corrosion, the test specimens shall be inspected frequently. For this reason, this type of specimen should not be tested with other specimens requiring tests of predetermined durations.

9.4 A periodic visual examination of specimens under test for a predetermined period may be made, but the surfaces under test shall not be disturbed, and the period for which the cabinet is open shall be the minimum necessary to observe and record any visible changes.

10 Treatment of specimens after test

At the end of the test period, remove the test specimens from the cabinet and allow them to dry for 0,5 h to 1 h before rinsing, in order to reduce the risk of removing corrosion products. Before they are examined, carefully remove the residues of spray solution from their surfaces. A suitable method is to rinse or dip the test specimens gently in clean running water, at a temperature not exceeding 40 °C, and then to dry them immediately in a stream of air, at an overpressure not exceeding 200 kPa and at a distance of approximately 300 mm.

NOTE ISO 8407 may be used for treatment of the specimen after test.

How to treat specimens after testing should, in line with good engineering practice, be included in the test specification.

11 Evaluation of results

Many different criteria for the evaluation of the test results may be applied to meet particular requirements, for example:

- a) appearance after the test;
- b) appearance after removing superficial corrosion products;
- c) number and distribution of corrosion defects, i.e. pits, cracks, blisters, rusting or creep from scratches in the case of organic coatings, etc.; these may be assessed by methods described in ISO 8993 or ISO 10289, and for organic coatings in ISO 4628, parts 1, 2, 3, 4, 5 and 8 (see Annex D);
- d) the time elapsing before the appearance of the first signs of corrosion;
- e) change in mass;
- f) alteration revealed by micrographic examination;
- g) change in mechanical properties.

NOTE It is good engineering practice to define the appropriate criteria in the specification for a coating or a product to be tested.

12 Test report

12.1 The test report shall indicate the outcome of the test according to the criteria for evaluation of results prescribed for the test. Report the result obtained for each specimen tested and, when appropriate, the average result for a group of replicate test specimens. Photographic records of the tested specimens may, if required, accompany the report.

12.2 The test report shall contain information about the test procedure. This information may vary according to the purpose of the test and to the directions prescribed for it, but a general list of the details likely to be required is as follows:

- a) a reference to this International Standard;
- b) type and purity of salt and water used;
- c) the description of the material or product tested;
- d) dimensions and shape of the test specimen, and the nature and area of the surface tested;

EN ISO 9227:2006 (E)

- e) preparation of the test specimen, including any cleaning treatment applied and any protection given to edges or other special areas;
- f) known characteristics of any coating, with an indication of the surface area;
- g) the number of test specimens subjected to the test representing each material or product;
- h) the method used to clean test specimens after the test with, where appropriate, an indication of the loss in mass resulting from the cleaning operation;
- i) the angle at which the tested surfaces were inclined;
- j) the frequency and number of specimen location permutations, if any;
- k) the duration of the test and the results of any intermediate inspections;
- l) the properties of any reference specimens placed in the cabinet to check the stability of the operating conditions;
- m) test temperature;
- n) the volume of collected solution;
- o) pH of the test solution and the collected solution;
- p) salt concentration or density of the collected solution;
- q) result of corrosion rate of reference specimens of steel, or for both steel and zinc (mass loss, g/m²);
- r) any abnormality or incident occurring during the entire test procedure;
- s) intervals of inspection.

Annex A (informative)

Schematic diagram of one possible design of spray cabinet with means for treating fog exhaust and drain

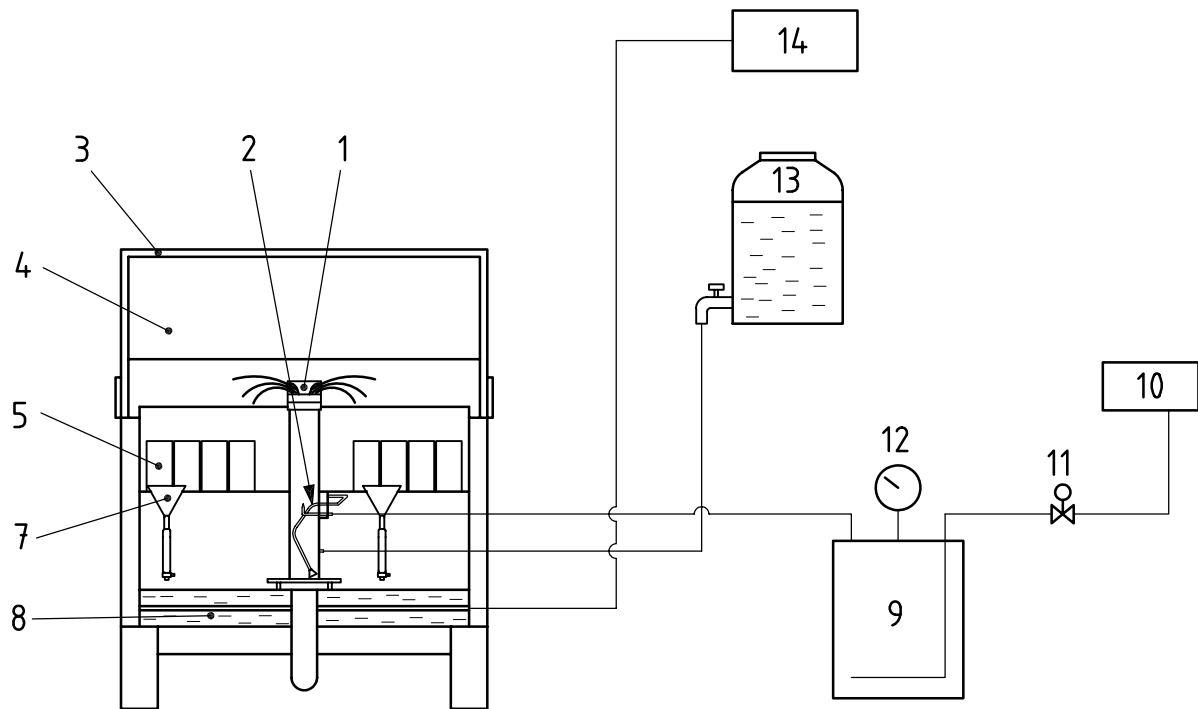

a) Front view

Key

- | | | | |
|----|-----------------------|----|----------------------------|
| 1 | mist dispersion tower | 11 | solenoid valve |
| 2 | atomizer | 12 | pressure gauge |
| 3 | cover | 13 | solution tank |
| 4 | test chamber | 14 | temperature controls |
| 5 | test specimen | 15 | exhaust-treatment disposal |
| 6 | test-specimen support | 16 | air-outlet port |
| 7 | fog collector | 17 | drain-treatment disposal |
| 8 | chamber | 18 | salt tray |
| 9 | air saturator | 19 | heating elements |
| 10 | air compressor | | |

Figure A.1

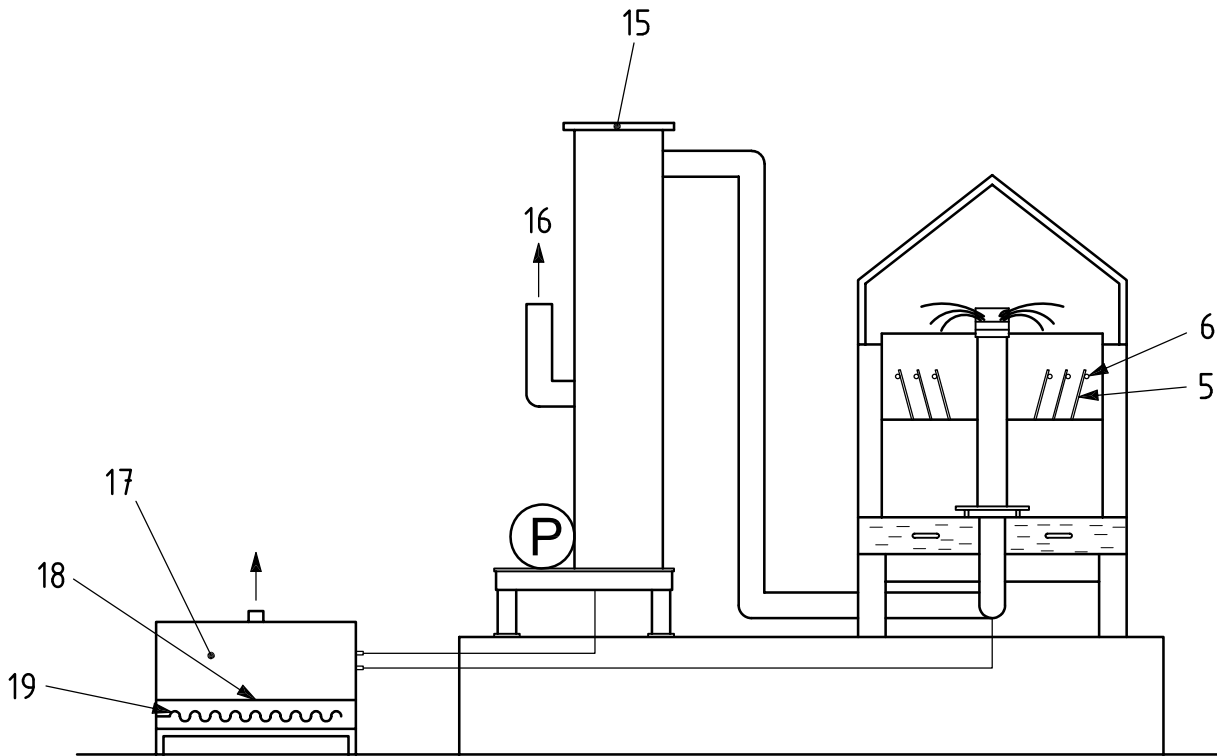

b) Side view

Key

- | | |
|-------------------------|-------------------------------|
| 1 mist dispersion tower | 11 solenoid valve |
| 2 atomizer | 12 pressure gauge |
| 3 cover | 13 solution tank |
| 4 test chamber | 14 temperature controls |
| 5 test specimen | 15 exhaust-treatment disposal |
| 6 test-specimen support | 16 air-outlet port |
| 7 fog collector | 17 drain-treatment disposal |
| 8 chamber | 18 salt tray |
| 9 air saturator | 19 heating elements |
| 10 air compressor | |

Figure A.1 (continued)

It is preferred that the apparatus has a means to properly treat the fog after the test, prior to releasing it from the building for environmental conservation and also to drain water prior to discharging it to the drainage.

Annex B (informative)

Complementary method for evaluation of the corrosivity of the cabinet by use of zinc reference specimens

B.1 Reference test specimen

As a complementary method for measurement of the corrosivity of the cabinet according to this International Standard, four or six reference specimens of zinc with an impurity level of less than 0,1 %, in mass fraction, may be used.

The reference specimens shall have dimensions of 50 mm × 100 mm × 1 mm.

Before testing, the reference specimens shall be cleaned carefully with a hydrocarbon solvent, in order to remove all evidence of dirt, oil, or other foreign matter capable of influencing the result from the corrosion-rate determination. After drying, the reference specimens shall be weighed to the nearest 1 mg.

Protect one face of the reference specimens with a removable coating, for example an adhesive plastic film.

B.2 Arrangement of the reference specimens

Position four reference specimens in four different quadrants (if six specimens are used, place them in six different positions including four quadrants) in the test cabinet, with the unprotected face upward, and at an angle of $20^\circ \pm 5^\circ$ from the vertical.

The support for the reference specimens shall be made of, or coated with, inert materials such as plastic, and be placed at the same level as the test specimens.

The recommended test duration is: for the NSS test 48 h, for the AASS test 24 h and for the CASS test 24 h.

B.3 Determination of mass loss

Immediately after the end of the test, firstly remove the protective coating. Then remove the corrosion products by repetitive cleaning as described in ISO 8407. Use for chemical cleaning of the zinc reference specimens a solution of saturated glycine, 250 g ± 5 g glycine, C₂H₅NO₂ (p.a.) per litre of deionized water.

The chemical cleaning procedure is preferably performed in repetitive steps of immersion of 5 min. After each immersion step, thoroughly clean the reference specimen at ambient temperature by rinsing with water and light brushing, then with acetone or ethanol, followed by drying. Weigh the reference specimen to the nearest 1 mg and plot the mass versus the actual cleaning cycle as described in ISO 8407.

NOTE For the efficient dissolution of the corrosion products during the immersion step, it is important that the solution is kept stirred. An ultrasonic bath may preferably be used for increasing the rate of dissolution.

From the plot of mass versus number of cleaning cycles, determine the true mass of the specimen after removal of the corrosion products as described in ISO 8407. Subtract this number from the initial mass of the reference specimen prior to testing, and divide the resulting number by the area of the exposed surface of the reference specimen to assess the metal mass loss per square metre of the reference specimen.

B.4 Satisfactory performance of cabinet

The cabinet has performed satisfactorily if the loss in mass of each steel and zinc reference specimen is within the allowed ranges given in Table B.1.

Table B.1 — Allowed range of mass loss of the zinc and steel reference specimens during verification of the corrosivity of the cabinet

Test method	Test duration	Allowed range of mass loss of the zinc reference specimens	Allowed range of mass loss of the steel reference specimens
	h	g/m ²	g/m ²
NSS	48	50 ± 25	70 ± 20 (see 5.2.4)
AASS	24	30 ± 15	40 ± 10 (see 5.3.4)
CASS	24	50 ± 20	55 ± 15 (see 5.4.4)

Annex D (normative)

Required supplementary information for testing test panels with organic coatings

The items of supplementary information listed in this annex shall be supplied, as appropriate.

The information required should preferably be agreed between the interested parties and may be derived, in part or totally, from an international or national standard or other document related to the system under test.

- a) Substrate material and surface preparation used (see C.1).
- b) Method of application of the test coating system to the substrate (see C.1).
- c) Duration and conditions of drying (or stoving) and ageing (if applicable) of the test panel before testing (see C.2).
- d) Thickness(es), in micrometres, of the dry coating(s), and method of measurement in accordance with ISO 2808, and whether it is a single coating or multi-coat system (see C.3).
- e) Number and location of scribe marks made prior to exposure (see C.4).
- f) Duration of the test.
- g) Characteristics considered in evaluating the resistance of the test coating and method(s) of inspection used.

Bibliography

- [1] ISO 1456:2003, *Metallic coatings — Electrodeposited coatings of nickel plus chromium and of copper plus nickel plus chromium*
- [2] ISO 1458:2002, *Metallic coatings — Electrodeposited coatings of nickel*
- [3] ISO 1513:1992, *Paints and varnishes — Examination and preparation of samples for testing*
- [4] ISO 3270:1984, *Paints and varnishes and their raw materials — Temperatures and humidities for conditioning and testing*
- [5] ISO 3613:2000, *Chromate conversion coatings on zinc, cadmium, aluminium-zinc alloys and zinc-aluminium alloys — Test methods*
- [6] ISO 3696:1987, *Water for analytical laboratory use — Specification and test methods*
- [7] ISO 4520:1981, *Chromate conversion coatings on electroplated zinc and cadmium coatings*
- [8] ISO 4527:2003, *Metallic coatings — Autocatalytic (electroless) nickel-phosphorus alloy coatings — Specification and test methods*
- [9] ISO 4628-1:2003, *Paints and varnishes — Evaluation of degradation of coatings — Designation of quantity and size of defects, and of intensity of uniform changes in appearance — Part 1: General introduction and designation system*
- [10] ISO 4628-2:2003, *Paints and varnishes — Evaluation of degradation of coatings — Designation of quantity and size of defects, and of intensity of uniform changes in appearance — Part 2: Assessment of degree of blistering*
- [11] ISO 4628-3:2003, *Paints and varnishes — Evaluation of degradation of coatings — Designation of quantity and size of defects, and of intensity of uniform changes in appearance — Part 3: Assessment of degree of rusting*
- [12] ISO 4628-4:2003, *Paints and varnishes — Evaluation of degradation of coatings — Designation of quantity and size of defects, and of intensity of uniform changes in appearance — Part 4: Assessment of degree of cracking*
- [13] ISO 4628-5:2003, *Paints and varnishes — Evaluation of degradation of coatings — Designation of quantity and size of defects, and of intensity of uniform changes in appearance — Part 5: Assessment of degree of flaking*
- [14] ISO 4628-8:2005, *Paints and varnishes — Evaluation of degradation of coatings — Designation of quantity and size of defects, and of intensity of uniform changes in appearance — Part 8: Assessment of degree of delamination and corrosion around a scribe*
- [15] ISO 7253:1996, *Paints and varnishes — Determination of resistance to neutral salt spray (fog)*
- [16] ISO 7599:1983, *Anodizing of aluminium and its alloys — General specifications for anodic oxide coatings on aluminium*
- [17] ISO 8993:1989, *Anodized aluminium and aluminium alloys — Rating system for the evaluation of pitting corrosion — Chart method*
- [18] ISO 8994:1989, *Anodized aluminium and aluminium alloys — Rating system for the evaluation of pitting corrosion — Grid method*

- [19] ISO 10289:1999, *Methods for corrosion testing of metallic and other inorganic coatings on metallic substrates — Rating of test specimens and manufactured articles subjected to corrosion tests*
- [20] ISO 15528:2000, *Paints, varnishes and raw materials for paints and varnishes — Sampling*
- [21] SHIGERU SUGA and SHIGEO SUGA, "Report on the results from the ISO/TC 156/WG 7 International Round Robin Test Programme on ISO 9227 Salt spray tests"; *J. Surface Finish. Soc. Japan*; Vol. **56**, p. 28 (2005)