



U.S. Department
of Transportation
**National Highway
Traffic Safety
Administration**

ODI RESUME

Investigation: PE09-050
Date Opened: 10/07/2009 Date Closed: 01/07/2010
Principal Investigator: Sonny Murianka
Subject: Rear Spring Trailing Arm Bolt Loose

Manufacturer: Freightliner LLC
Products: 2008-2011 Thomas Built C-2 School Buses
Population: 3,739

Problem Description: Rear spring trailing arm bolts were found to be loose.

FAILURE REPORT SUMMARY

	ODI	Manufacturer	Total
Complaints:	13	13	13
Crashes/Fires:	0	0	0
Injury Incidents:	0	0	0
# Injuries:	0	0	0
Fatality Incidents:	0	0	0
# Fatalities:	0	0	0
Other:	0	0	0

Description of Other:

Action: This investigation has been closed. Daimler has filed a Safety Recall (09V-458) to resolve this issue.

Engineer: Sonny Murianka
Div. Chief: Richard Boyd
Office Dir.: Kathleen C. DeMeter

Date: 01/07/2010
Date: 01/07/2010
Date: 01/07/2010

Summary:

This investigation was opened after ODI was informed by two school bus fleets that they had found loose bolts on the rear suspension trailing arms of the air ride suspension on several of their buses. ODI visited the local dealer and confirmed the loose bolts. If these bolts fail and separate, the rear suspension can shift, allowing the rear end housing to move forward or backward. This could have a detrimental impact on vehicle control.

In late November 2009, Daimler filed a Safety Recall (09V-458) outlining their Remedy Program. Daimler will inspect and torque all the rear suspension fasteners as needed. A copy of the recall notification is attached.

The action taken by Daimler resolves this investigation. Accordingly, this investigation is closed.

DAIMLER

09V 458
PE-09-050

Daimler Trucks North America
Nasser Zamani
Senior Manager
Compliance and Regulatory Affairs

November 30, 2009

Dan Smith
Associate Administrator for Enforcement
National Highway Traffic Safety Administration
Attention: Recall Management Division (NVS-215)
1200 New Jersey Avenue S.E.
Washington D.C. 20590

Re: Defect Information Report FL-567, Rear Suspension Hanger Bolts

Mr. Smith

In accordance with Part 573 of Title 49 of the Code of Federal Regulations, Daimler Trucks North America LLC herewith reports a safety campaign to recall approximately 3,739 Thomas Build School Buses manufactured June 1, 2007, through September 28, 2009 and equipped with 23,000 pound rear air suspensions.

Attached is Daimler Trucks North America's Defect Information Report.

Please contact me if you have any questions.

Sincerely yours,



Nasser Zamani

Cc: Michael Mason, CAL-OSHA
Enclosure
Certified Mail# 7006 3450 0000 3866 7751

A Daimler Company

Daimler Trucks North America LLC
4747 N. Channel Avenue
Portland OR 97217-7699
503-745-6910 Phone
503-745-5544 Fax
Nasser.Zamani@Daimler.com

DAIMLER

Defect Information Report

(Section 573.6)

November 30, 2009

(c)(1) **Manufacturer:** Daimler Trucks North America LLC
P.O. BOX 3849
Portland, Oregon 97208
(503) 745-5219

Brands: Freightliner Custom Chassis, Thomas Built Buses

(c)(2) **Vehicles identification:**

Model(s) affected: FCCC - B2 Chassis

TBB - Saf-T-Liner C2 School bus

Model Years affected: TBB Model Years 2008 through 2011

Manufacture Dates: June 1, 2007, through September 28, 2009

Basis for determining population: B2 chassis assembled at Gaffney with 23k Airliner rear suspensions June 1, 2007, through September 28, 2009

Component manufacturer if other than the vehicle manufacturer: Not Applicable

(c)(3) **Total number of vehicles potentially affected:** Approximately 3,739

(c)(4) **Percentage of vehicles estimated to contain the defect:** 2%

(c)(5) **Description of the defect:** Fasteners used to connect the rear suspension spring to the suspension hanger bracket may not have been torqued to specification. Under torqued fasteners may become loose and potentially fall out.

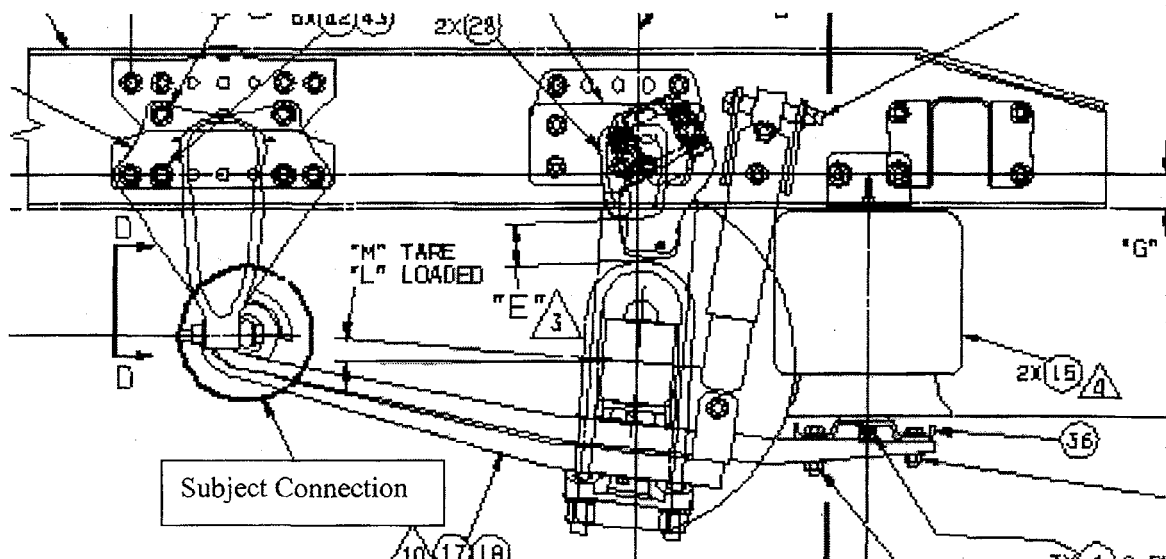

49CFR Section 577.5(f) Evaluation of the risk to motor vehicle safety: Loose or missing fasteners may allow the rear suspension to become misaligned increasing the risk of a crash.

DAIMLER

(c)(6) **Chronology of principal events:** September 2009 – Received complaints of loose fasteners, October 2009 – Field inspection of suspect units indicated a potential 2% failure rate

(c)(7) **Noncompliance-test or other data:** Not Applicable

(c)(8) **(i) Remedial program:** Fastener torque will be inspected and adjusted as required. Damaged fasteners will be replaced. Repairs will be performed by Daimler Trucks North America dealerships and Direct Warranty customers, i.e., customers approved by Daimler Trucks North America to do their own warranty repairs
Reimbursement Plan: Copies will be submitted as a supplemental report when available.

(ii) Estimated Owner and Dealer Notification Date: Customer notification will be by first class mail using Daimler Trucks North America records to determine the customers affected. This will be completed approximately February 19, 2010
Dealer notification will be completed approximately February 19, 2010

(c)(9) **Information for tire recalls:** Not Applicable

(c)(10) **Communications sent to manufacturers, dealers and owners:** Copies will be submitted as a supplemental report when available.

(c)(11) **Manufacturer's campaign number:** FL-567