

**Howell, Rosa <NHTSA>**

---

**From:** York, Bruce <NHTSA>  
**Sent:** Thursday, July 10, 2008 12:27 PM  
**To:** Howell, Rosa <NHTSA>  
**Subject:** FW: PE08-009 Question 15 - Power Steering Pump  
**Attachments:** TRW Manual - EVPUMP.pdf; 15 draft.doc

---

**From:** stephen.payne@daimler.com [mailto:stephen.payne@daimler.com]  
**Sent:** Wednesday, July 02, 2008 5:47 PM  
**To:** York, Bruce <NHTSA>  
**Cc:** nasser.zamani@daimler.com; david.stanley@daimler.com  
**Subject:** PE08-009 Question 15 - Power Steering Pump

Bruce,  
Attached is the Daimler Trucks North America response to Question 15 of PE08-009 for the TRW Power Steering Pump. Please consider this response confidential. We are working to formalize the confidentiality request within NHTSA's guidelines in the in PE letter but I don't want to delay sending this today.

Please let me know if you need more information

Steve Payne  
Compliance and Regulatory Affairs  
Daimler Trucks North America

Steve.Payne@Daimler.com  
503/745-8063

If you are not the intended addressee, please inform us immediately that you have received this e-mail in error, and delete it. We thank you for your cooperation.

7/10/2008

PE08-009  
FREIGHTLINER  
7/2/2008  
ATTACHMENT  
TRW MANUAL

# Power Steering Pump Service Manual

EV SERIES



# Hazard Warning Definitions

<b>⚠ WARNING</b>	A warning describes hazards or unsafe practices which could result in severe personal injury or death.
<b>⚠ CAUTION</b>	A caution describes hazards or unsafe practices which could result in personal injury or product or property damage.
<b>NOTE</b>	A note gives key information to make following a procedure easier or quicker.

## Disclaimer

This Service Manual has been prepared by TRW Commercial Steering Systems for reference and use by mechanics who have been trained to repair and service steering components and systems on heavy commercial vehicles. TRW Commercial Steering Systems has exercised reasonable care and diligence to present accurate, clear and complete information and instructions regarding the TRW Commercial Steering EV Series Power Steering Pumps. Since this is a general Service Manual, the photographs and illustrations may not look exactly like the pump being serviced. The procedures, therefore, must be carefully read and understood before servicing.

If inspection or testing reveals evidence of abnormal wear or damage to the EV pump or if you encounter circumstances not covered in the Manual, **STOP - CONSULT THE VEHICLE MANUFACTURER'S SERVICE MANUAL AND WARRANTY. DO NOT TRY TO REPAIR OR SERVICE AN EV POWER STEERING PUMP WHICH HAS BEEN DAMAGED OR INCLUDES ANY PART THAT SHOWS EXCESSIVE WEAR UNLESS THE DAMAGED AND WORN PARTS ARE REPLACED WITH ORIGINAL TRW REPLACEMENT AND SERVICE PARTS AND THE UNIT IS RESTORED TO TRW'S SPECIFICATIONS FOR THE EV POWER STEERING PUMP.**

It is the responsibility of the mechanic performing the maintenance, repairs or service on a particular EV power steering pump to (a) inspect the pump for abnormal wear and damage, (b) choose a repair procedure which will not endanger his/her safety, the safety of others, the vehicle, or the safe operation of the vehicle, and (c) fully inspect and test the EV pump and the vehicle steering system to ensure that the repair or service of the pump has been properly performed and that the pump and system will function properly.

## Patents

The TRW Commercial Steering Systems EV Series Power Steering Pump is covered by several United States and foreign patents, either issued or pending.

# Table of Contents

<b>Section 1</b>	<b>General Information</b>	
	Introduction .....	4
	General Design & Operation .....	5
	Torque Chart .....	6
	Specification Numbers .....	6
	Part Number Breakdown .....	7
	Service Parts List .....	8
	Exploded View .....	9
	Oil Flow Illustration .....	10
	Approved Hydraulic Fluids .....	10
<b>Section 2</b>	<b>Installation</b>	
	Installation Procedures .....	12
	Maintenance Tips .....	13
<b>Section 3</b>	<b>Reseal &amp; Repair</b>	
	Disassembly Preparation .....	17
	Disassembly .....	18
	Inspection .....	22
	Assembly Preparation/Assembly .....	24
<b>Section 4</b>	<b>Reinstallation</b>	
	Reinstallation .....	31
	Glossary .....	32

**⚠ CAUTION**

It is imperative that the instructions in this booklet be followed to the letter. Failure to observe the procedures may result in a loss of steering.

## **Section 1            General Information**

Introduction .....	4
General Design & Operation .....	5
Torque Chart .....	6
Specification Numbers .....	6
Part Number Breakdown .....	7
Service Parts List .....	8
Exploded View .....	9
Oil Flow Illustration .....	10
Approved Hydraulic Fluids .....	10

# Introduction

The three-column format used in the Service Manual will help make it easy for you to service a power steering pump. Column 1 illustrates the procedure with photographs, column 2 gives a brief key as well as tools to be used for each procedure, and column 3 explains in detail the procedure you should follow. **Pay special attention to the notes, cautions and warnings.**

Item numbers on the exploded view correspond with item numbers used throughout this service manual.

As you gain experience in servicing EV Series power steering pumps, you may find that some information in this Service Manual could be clearer and more complete. If so, let us know about it. Don't try to second-guess the Service Manual; if you do not understand a procedure, or are stuck, contact our Field Service Department at 1-800-TRW-0899. Servicing EV Series pumps should be safe and productive.

# General Operation

## What is a Power Steering Pump?

The pump is the heart of the hydraulic steering system. It converts the rotational energy supplied by the engine into hydraulic energy, flow and pressure, for use by the steering gear.

## Theory of Operation

All pumps function by creating a partial vacuum at the inlet, which causes atmospheric pressure to force fluid into the pump from the reservoir. The pump then pushes this fluid into the system for use. The fluid is used to power the steering gear. Pump output flow relates to steering gear speed and pump output pressure relates to steering gear force (work).

# General Design

## Description of the EV Series Power Steering Pump

The EV Series power steering pump is a balanced, positive displacement, sliding vane type, two line pump with an internal pilot operated flow control and relief valve. The components of this description are broken down and explained below:

### Balanced

The pumping element has two pumping pockets opposed 180° from each other which balance the internal forces due to the pressure generated by the pumping action.

### Positive Displacement

The pump will output a fixed volume for each revolution of the input shaft. The fixed volume is determined by the internal contour of the cam ring.

### Sliding Vane Type

This describes the type of pumping element. The EV pumping element consists of three components.

1. The rotor that holds the vanes and is driven by the engine with the pump input shaft.
2. The vanes that slide back and forth in slots in the rotor while following the internal contour of the cam ring as the rotor is being turned, thus a sliding vane.
3. The cam ring that contains the internal contour that defines the amount of fluid that is output with each revolution of the rotor.

### Two Line

The EV pump requires an inlet line to supply oil to the pump and an outlet line to take the oil supplied by the pump to the steering gear. All excess (bypass) oil is diverted internally in the pump housing back to the inlet of the pumping element. Other systems may have a third line which takes this excess oil back to the reservoir.

### Internal flow Control Valve

The pump has a pilot operated valve built into the pump housing that will control the amount of oil that is output to the steering gear. This allows the output flow to remain within specification for almost any input speed variation.

### Relief Valve (if equipped)

The pump has a pilot operated relief valve built into the flow control valve spool which will limit the maximum pressure the pump can produce. When the pressure limit has been reached, the relief section will cause the flow control to bypass more oil internal to the pump, limiting the outlet pressure.

# Torque Chart

Part Name	Item #	Torque Dry
Bolts (4)	19	24 ft•lb (33 N•m)
Relief valve seat assembly	3E	7 ft•lb (9 N•m)
Plug	6	65 ft•lb (88 N•m)
Pressure port (outlet)		37 ft•lb maximum (50 N•m)
Suction port (inlet)		74 ft•lb maximum (100 N•m)

Item numbers referenced above are shown on the exploded view on page 9 .

# Specification Numbers

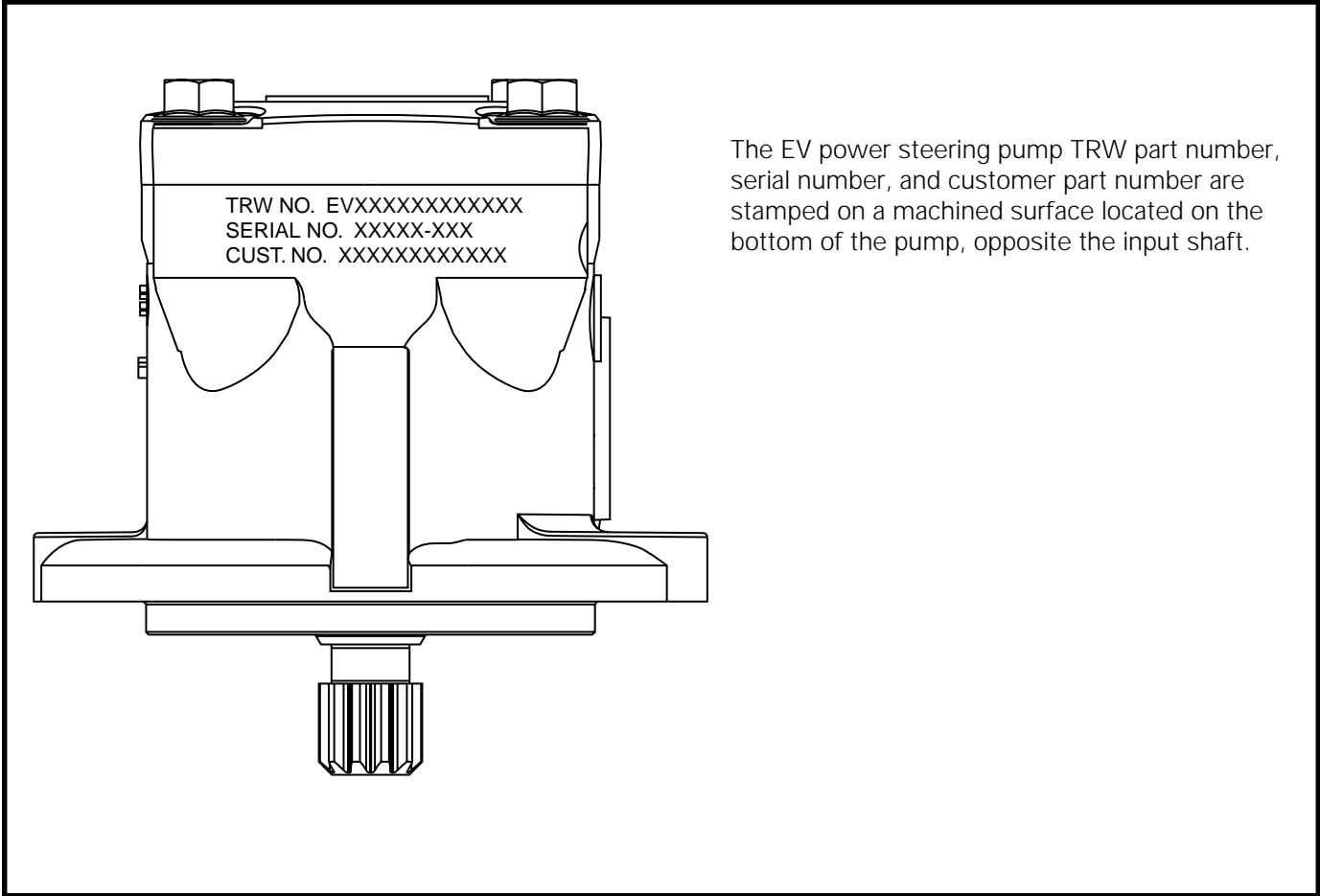

# Part Number

**EV 18 12 15 R 1 01 00**

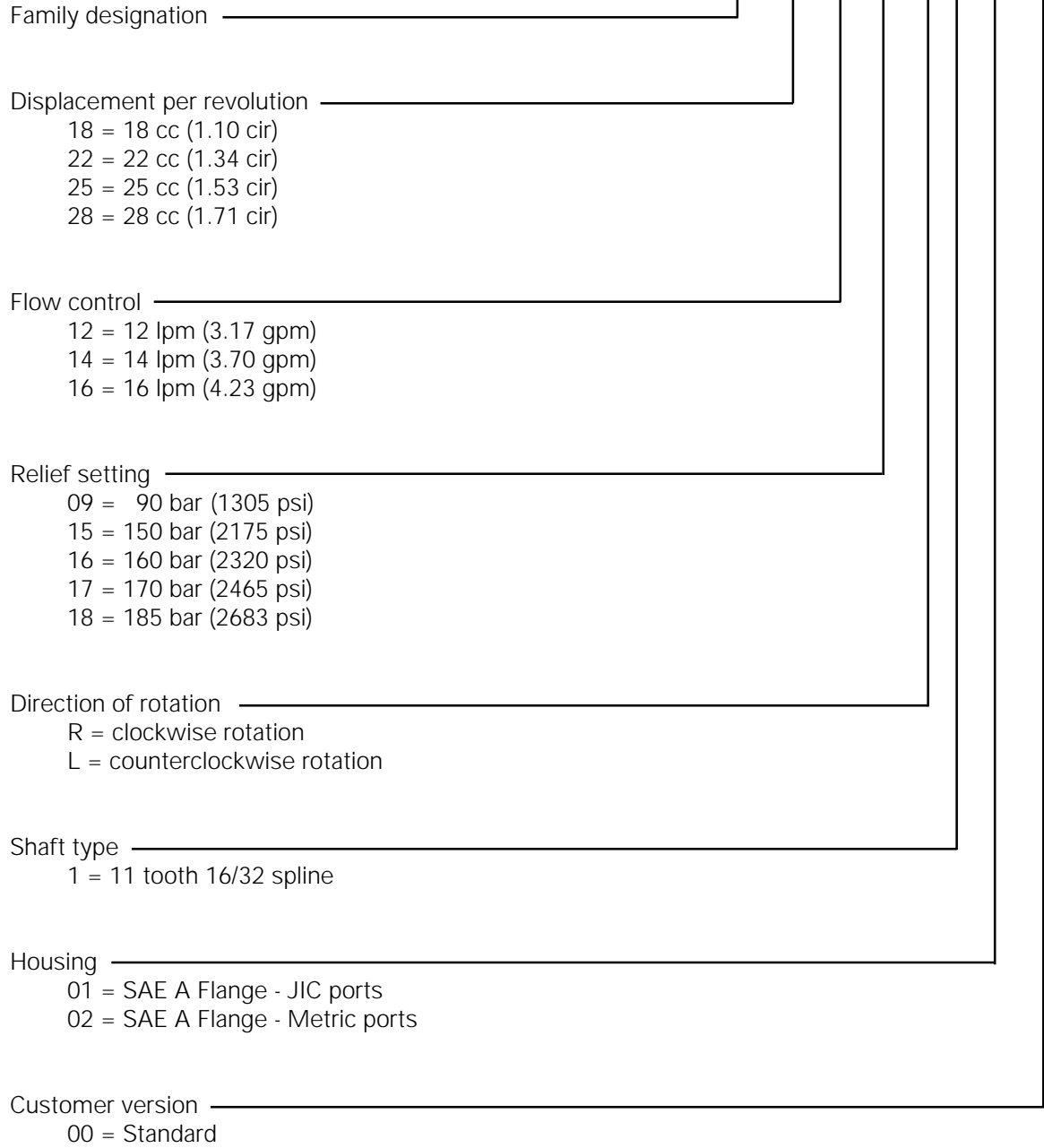

# Service Parts List

<u>Item</u>	<u>Description</u>	<u>Part Number</u>
	Seal Kit (Includes following parts)	SK000255
2	Shaft seal	032847
5	O-ring seal	032845
8	O-ring seal	032852
11	O-ring seal	032853
17	O-ring seal	032851
	Grease pack	406036
	MSDS sheet	A10007

# EV Series Exploded View

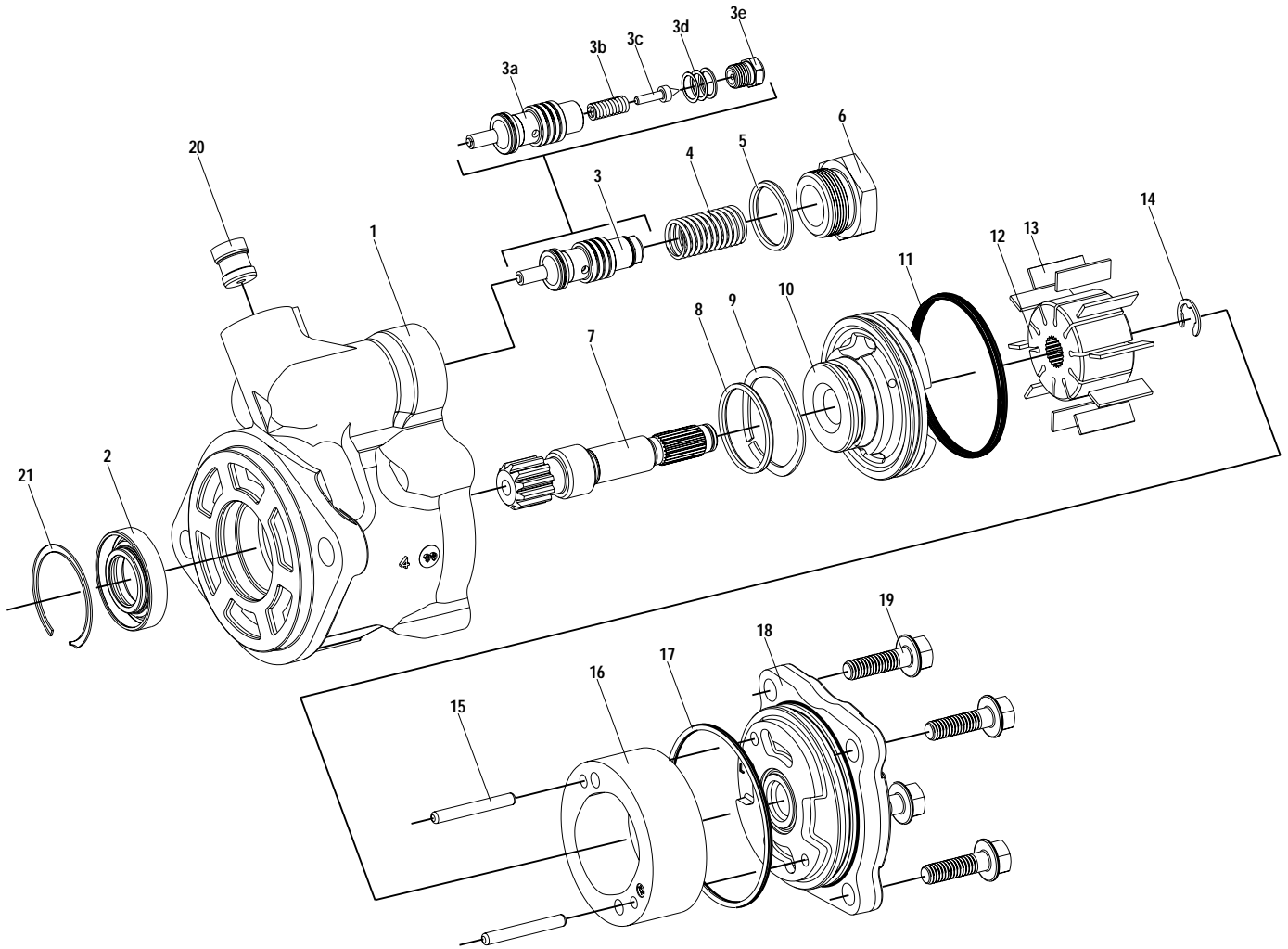

- 1 Housing
- 2 Shaft seal
- 3 Valve spool assembly
  - a. Spool
  - b. Spring
  - c. Poppet
  - d. Shims
  - e. Relief valve seat assembly
- 4 Spring
- 5 O-ring

- 6 Plug
- 7 Input shaft
- 8 O-ring
- 9 Wave spring
- 10 Pressure plate
- 11 O-ring
- 12 Rotor
- 13 Vanes
- 14 E-ring
- 15 Locating pins

- 16 Cam ring
- 17 O-ring
- 18 End cover
- 19 Bolts (4)
- 20 Orifice
- 21 Snap ring

# Oil Flow Illustration

- Outlet Pressure
- Boost Pressure
- Pilot Pressure
- Seal Drain
- Inlet Pressure

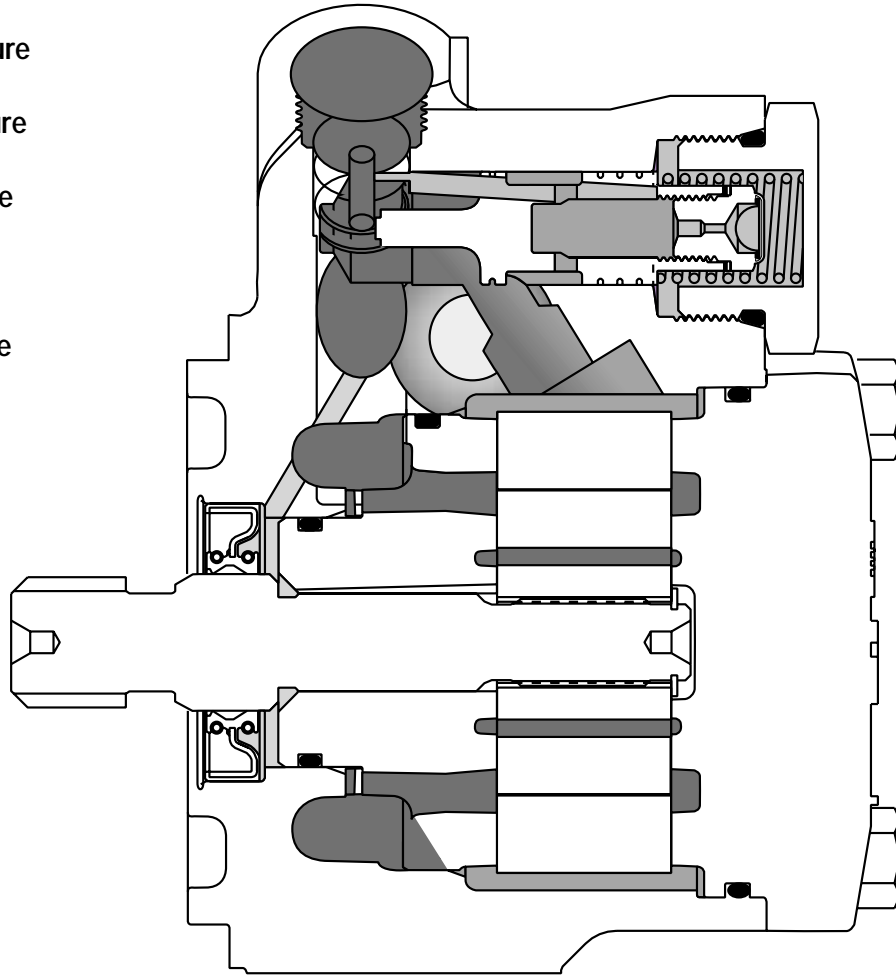

## Approved Hydraulic Fluids

Automatic Transmission Fluid Dexron II  
Automatic Transmission Fluid Type "E" or "F"  
Chevron 10W-40  
Chevron Custom 10W-40 Motor Oil  
Chevron Torque 5 Fluid  
Exxon Nuto H32 Hydraulic Fluid  
Fleetrite PSF (Can #990625C2)  
Ford Spec. M2C138CJ  
Mack EO-K2 Engine Oil

Mobil ATF 210  
Mobil Super 10W-40 Motor Oil  
Premium Blue 2000 - SAE 15W-40  
Texaco 10W-40  
Texaco TL-1833 Power Steering Fluid  
Union 10W-40  
Union 15W-40  
Unocal Guardol 15W-40 Motor Oil

The steering system should be kept filled with an approved hydraulic fluid specified by your OEM or with one of the above fluids listed above.

### **⚠ WARNING**

Completely flush the steering system with one of the recommended fluids above only. Do not mix oil types. Any mixture or any unapproved oil could lead to seal deterioration and leaks. A leak could ultimately cause the loss of fluid, which could result in a loss of power steering assist.

## **Section 2      Initial Installation**

Installation .....	12
Maintenance Tips .....	13

# Initial Installation

1. Install fittings to input and output ports, if fittings for this application can be preinstalled.
2. Position either a gasket or o-ring, dependent on the application, which will seal the pump face to the mounting surface.
3. Engage the input shaft and pilot
4. Tighten the mounting bolts to manufacturer's specifications.
5. Connect the input and output lines.
6. Fill the reservoir.
7. Start the vehicle to purge the system and increase engine speed to prime the pump
8. Turn off the vehicle and check the fluid level in the reservoir. Add fluid as necessary.
9. Bleed the system, if necessary, using instructions in your steering gear service manual.

# Maintenance Tips

- **Never high-pressure wash or steam clean a power steering pump while off the vehicle. Doing so could force contaminants inside the pump and cause it to malfunction.**
- **Regularly check the fluid** and the fluid level in the power steering reservoir.
- **Encourage drivers to report any malfunctions or accidents** which could have damaged steering components.
- **Do not attempt to weld any broken steering component.** Replace the component with original equipment only.
- **Do not cold-straighten, hot straighten, or bend any steering system component.**
- Always **clean off around the reservoir filler cap** before you remove it. Prevent dirt or other foreign matter from entering the hydraulic system.
- **Investigate and correct any external leaks,** no matter how minor.
- **Replace reservoir filters** according to requirements.
- If you feel the vehicle is developing excessive **high hydraulic fluid temperatures,** consult with your vehicle manufacturer for recommendations.

This page intentionally left blank.

## **Section 3      Reseal & Repair**

Disassembly .....	17
Inspection .....	22
Assembly .....	24

**This page intentionally left blank.**

# Disassembly Preparation

Clean off all outside dirt from around fittings and hose connections before you remove the pump.

Remove the pump from the vehicle and take it to a clean work surface.

Clean and dry the pump before you start to disassemble it.

As you disassemble the pump, clean all parts in clean, OSHA approved solvent, and air blow-dry them only.

**⚠ WARNING** Because they are flammable, be extremely careful when using any solvents. Even a small explosion or fire could cause injury or death.

**⚠ WARNING** Wear eye protection and be sure to comply with OSHA or other maximum air pressure requirements.

**⚠ CAUTION** CAUTION: Never steam clean or high-pressure wash hydraulic steering components. Do not force or abuse closely fitted parts. Use care that bearing and sealing surfaces are not damaged by the assembly and disassembly procedures.

Keep each part separate to avoid nicks and burrs.

# Disassembly

## Tools Required

Vise  
Needle-nose pliers  
Small screwdriver  
Soft hammer  
Sockets: 1/2", 7/16", 1-1/16"  
1-1/4"

Collet  
Press

## Materials Required

Spacer: ID 3-1/4", depth 3"

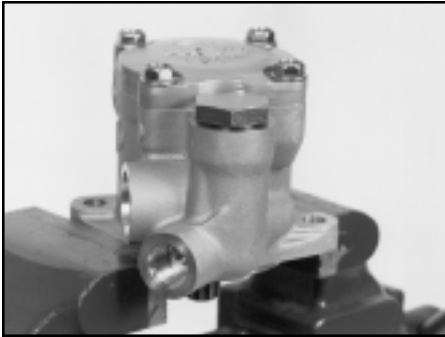

### Position pump in vise

Vise

1. Place the pump in a vise, clamping firmly on the flange area. Do not deform the housing with excessive clamping force.

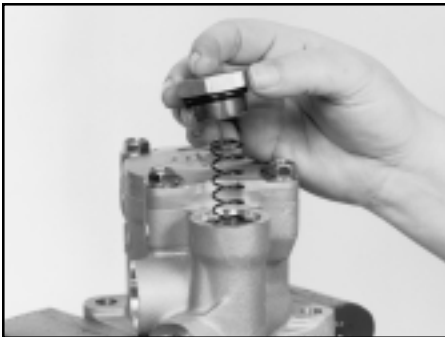

### Remove plug

1-1/4" Socket

2. Prepare for fluid drainage. Wear eye protection (the plug is spring-loaded) and remove the hydraulic plug (6) and o-ring (5). Discard the o-ring.



### Remove spring

3. Remove the spring (4), if it didn't come out with the plug.

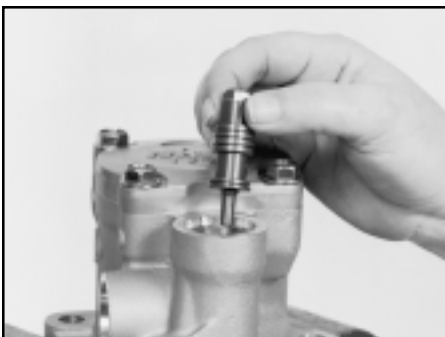

### Remove valve spool assembly

Needle-nose pliers

4. Remove the valve spool assembly (3) using needle-nose pliers (if necessary).

Note whether or not the valve spool assembly slides freely in the housing.

**CAUTION** Be careful not to damage spool or spool bore surface when removing the spool assembly (3).

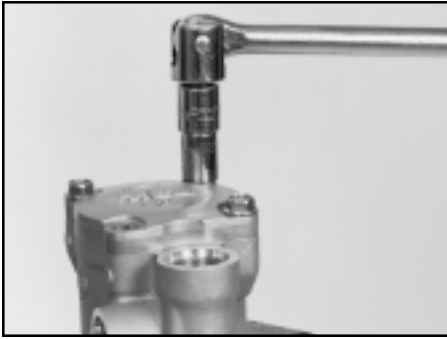

**Remove bolts**

1/2" Socket

5. Prepare for fluid drainage and remove 4 bolts (19).

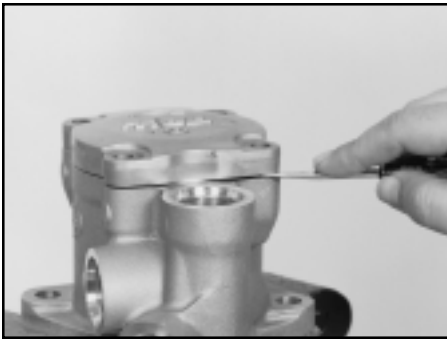

**Remove housing**

Small screwdriver

6. Separate the end cover (18) from the housing by prying with a small screwdriver.

**CAUTION** Be careful not to damage the end cover sealing surface when removing the end cover.



**Remove o-ring**

Small screwdriver or pick

7. Remove the o-ring (17) from the end cover. Discard.



**Loosen rotating group**

Soft hammer

8. Tip the assembly in the vise and tap lightly on the end of the input shaft with a soft hammer until the rotating group just breaks free.



**Remove rotating group**

9. Remove the assembly from the vise. Cover the housing bore opening with your hand and turn the assembly upside-down. Push on the input shaft until the rotating group falls into your hand.



**Remove locating pins**

10. Remove the locating pins (15).

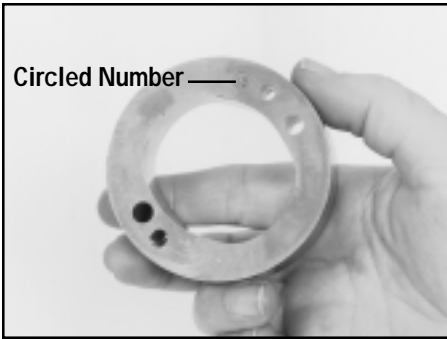

**Circled Number** —

**Remove cam ring, locate number**

11. Remove the cam ring (16). Note and record whether the circled, indented number near the locating pin holes on the cam ring is up or down.

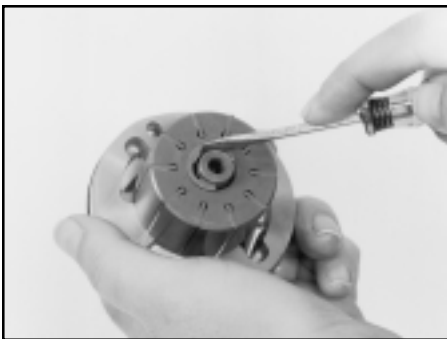

**Remove e-ring**

Small  
screwdriver

12. Remove the e-ring (14) using a small screwdriver.

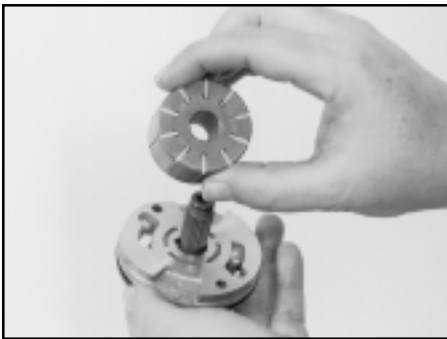

**Remove rotor and vanes**

13. Look for wear on the face of the vanes. Remove the rotor (12) and vanes (13) carefully, being prepared for the vanes to slip from their slots in the rotor.



**Remove input shaft**

14. Push the input shaft (7) out of the pressure plate (10).



**Remove o-rings and wave spring**

15. Remove two o-rings (8 & 11), and the wave spring (9) from the pressure plate (10).



**Remove snap ring**

16. Use a small screwdriver to remove the snap ring (21) near the input shaft seal.

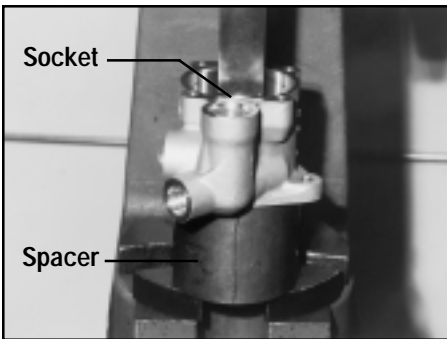

**Remove shaft seal**

Press  
1-1/16" socket  
Spacer: 3-1/4" ID,  
3" deep

17. Press the shaft seal (2) out of the housing, being careful not to damage the bore. Discard the shaft seal.

**CAUTION** Damage to the bore could cause leakage.

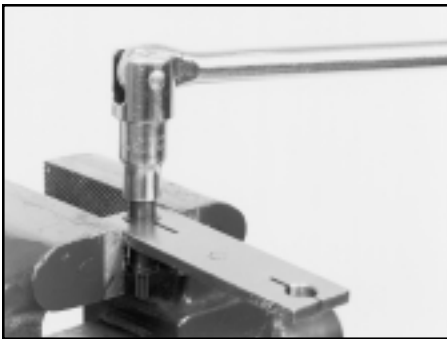

**Remove relief valve seat assembly**

Collet  
7/16" Socket

18. Remove the relief valve seat assembly (3E) from the valve spool assembly (3). Place the spool in a collet if necessary to begin the removal. The seat assembly is spring-loaded. Complete the removal by hand and prepare to catch the components.

**CAUTION** Take care not to deform the spool nor make nicks or burrs on the surface. If the spool is damaged, the pump must be replaced.

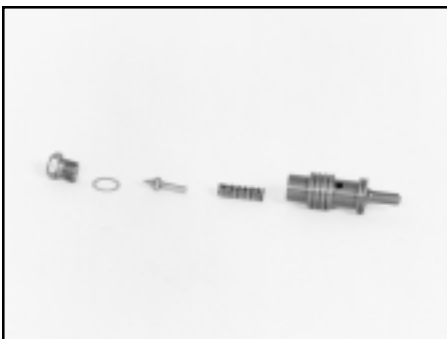

**Remove spool assembly components**

19. Remove the shims (3D) (make sure to count them), poppet (3C) and spring (3B) from the spool (3A).

# Inspection

Make sure all sealing surfaces and seal cavities are free from nicks and corrosion. Any nicked or corroded surface requires part replacement to ensure proper sealing.

Wash all parts in clean, OSHA approved solvent. Air blow them dry only.

**⚠ WARNING** Because they are flammable, be extremely careful when using any solvents. Even a small explosion or fire could cause injury or death.

**⚠ WARNING** Wear eye protection and be sure to comply with OSHA or other maximum air pressure requirements.



## Inspect housing

1. Inspect the housing (1) for cracks, stripped threads, damaged valve bore and damaged sealing areas. Make sure the seal drain hole is open.



## Inspect end cover

2. Inspect the end cover (18) for nicks in o-ring seal grooves.

Inspect the plate area for seal area nicks, and abnormal wear or erosion. A polished pattern from the rotor and vanes is normal, grooves you can feel with your fingernail are not normal and require pump replacement.



## Inspect cam ring

3. Look for obvious damage on the inside of the cam ring (16) like abnormal wear, erosion or surface imperfections. Grooves you can feel with your fingernail are not normal and require pump replacement.



## Inspect rotor and vanes

4. Inspect the rotor (12) and vanes (13) for abnormal wear or damage. There will be normal polish marks on both the top and bottom. Grooves you can feel with your fingernail are not normal and require pump replacement.

The vanes need to be free to slide both up and down and in and out. If vanes are removed for inspection, make sure to reinstall them with the rounded edge out.



**Inspect pressure plate**

5. Check the pressure plate (10) for abnormal wear patterns. Grooves you can feel with your fingernail are not normal and require pump replacement.



**Inspect input shaft**

6. Check the input shaft (7) for damaged splines and unusual wear or grooves around the shaft seal area. Grooves you can detect with your fingernail necessitate replacement of the pump.



**Inspect spool components**

7. Inspect spool components as follows: Check all components for damage. Check the relief valve seat assembly (3E) for wear or chipping. Back flush with air and solvent if necessary. Check the spool for nicks or burrs. Grooves you can feel with your fingernail are not normal and require pump replacement.

# Assembly Preparation

Wash all parts in clean, OSHA approved solvent. Air blow-dry them only.

**⚠ WARNING** Because they are flammable, be extremely careful when using any solvents. Even a small explosion or fire could cause injury or death.

**⚠ WARNING** Wear eye protection and be sure to comply with OSHA or other maximum air pressure requirements.

## Assembly

Tools Required		Materials Required
Ft•Lb Torque wrench	Sockets: 1/2", 7/16", 1-1/4"	Seal Kit (if resealing the pump)
Press	1-11/16" (2)	Grease (provided in kit)
Ratchet	Vise	Shop towel
J37073		Spacers for press
Needle-nose pliers		

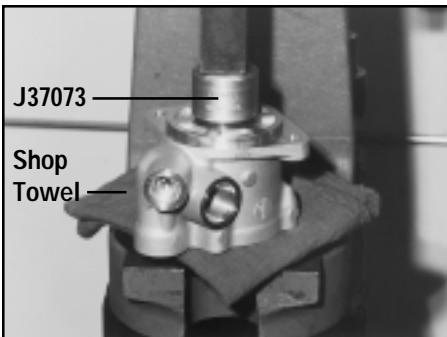

### Press in shaft seal

Press  
Kent Moore  
tool J37073

1. Press the shaft seal into the housing, with the lettered side facing toward the housing. The installed seal should be flush with, or just below the sealing surface on the housing.

**⚠ CAUTION** Make sure the press is clean and free of debris, and cover with a shop towel so as not to damage the face of the cover on which the housing rests. If damage occurs to the housing, the pump will not function properly.



### Install snap ring

2. Install the input shaft seal snap ring (21). Make sure it is fully seated in the groove.

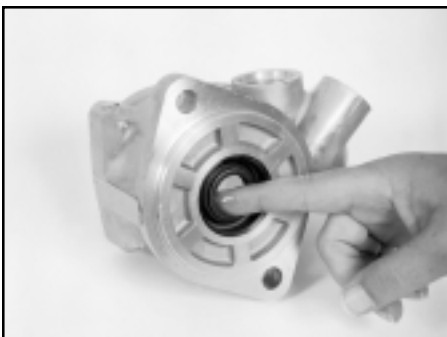

### Grease shaft seal

Grease

3. Grease the inside diameter of the shaft seal (2) with the special grease provided.



**Install large o-ring**

4. Install the large o-ring (11) into its groove on the pressure plate (10), with the flat side out.

**⚠ CAUTION** Do not twist or distort the o-ring when installing.

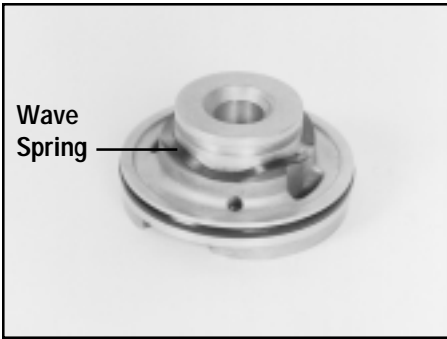

**Install wave spring**

5. Install the wave spring (9).



**Install small o-ring**

6. Install the small o-ring (8) into its groove.

**⚠ CAUTION** Do not twist or distort the o-ring when installing.

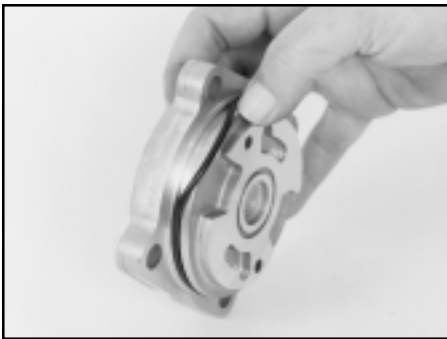

**Install end cover o-ring**

7. Install the o-ring (17) on the end cover (18). Make sure it is seated properly.

**⚠ CAUTION** Do not twist or distort the o-ring when installing.



**Install pressure plate**

8. Insert the input shaft (7) into the pressure plate (10). The machined surface of the pressure plate should be toward the narrower splines on the input shaft.

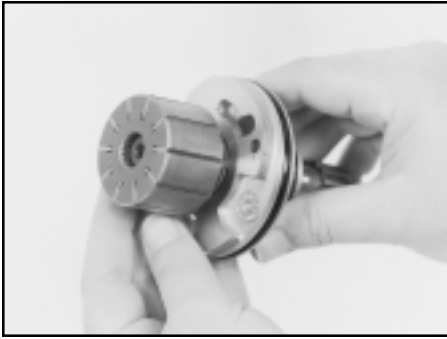

**Install rotor**

9. Install the rotor (12).



**Install e-ring**

Needle nose  
pliers

10. Install the e-ring using needle nose pliers. Make sure the clip is seated properly in its groove.

**⚠ WARNING** E-ring may become a projectile when being installed using this method. Use safety glasses for eye protection.

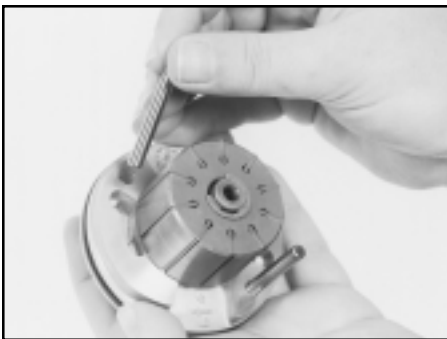

**Install locating pins**

11. Install the locating pins (15).



**Install cam ring and vanes**

12. Install the cam ring (16) with the numbers facing up OR down as noted during disassembly. Locating pins go into the smaller holes. The elongated locating pin hole on the pressure plate aligns with the elongated locating pin hole in the cam ring.

The installed cam ring should be fairly flush with the pressure plate at the large outside diameter.

Make sure all vanes (13) are installed with the squared edge toward the center of the rotor.

**NOTE** If not sure whether the circled indented number should go up or down: Check to see if the end cover is marked with an "R" or an "L". An "R" means the number on the cam goes up; an "L" means the number on the cam goes down.

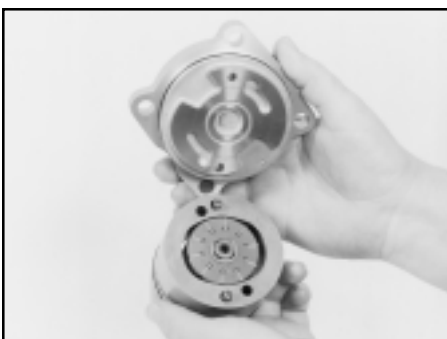

**Install end cover**

13. Install the end cover (18), aligning the holes with the locating pins. The elongated locating pin hole in the end cover aligns with the similar holes in the pressure plate and cam ring.

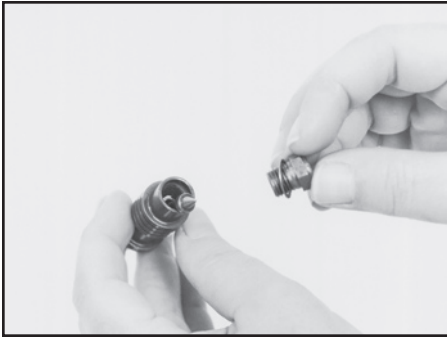

### Assemble valve spool assembly

14. Assemble valve spool components: Insert spring (3B), and poppet (3C) (blunt end first) into the spool (3A). Install shims (3D) onto the relief valve seat assembly (3E).

Make sure to install the same number of shims as were removed.

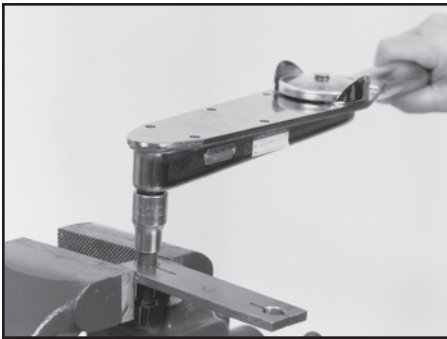

### Install relief valve seat assembly

7/16" Socket  
Torque wrench

15. Screw the relief valve seat assembly (3E) into the spool (3A) and **torque to 7 ft•lb (9 N•m)**. Placing the spool in a collet will facilitate torquing.

**⚠ CAUTION** Take care not to deform the spool nor make nicks or burrs on the surface. If the spool is damaged, the pump must be replaced.

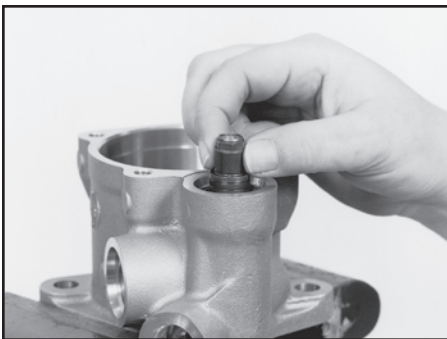

### Install valve spool assembly

16. Insert the valve spool assembly (3), screen end last, into the housing. Make sure the spool slides freely in the housing. If the cleaned spool does not slide freely, replace the pump.

### ⚠ WARNING

Do not install the valve spool backwards; doing so disables the pressure relief function of the pump. Serious personal injury may occur if hydraulic components burst due to over-pressurizing the power steering system.

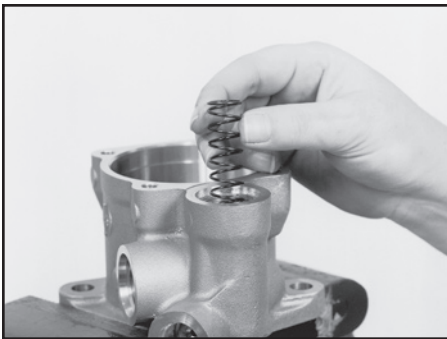

### Install spring

17. Install the spring (4).



### Install o-ring

18. Install a new o-ring (5) onto the plug (6).

**⚠ CAUTION** Do not twist or distort the o-ring when installing.

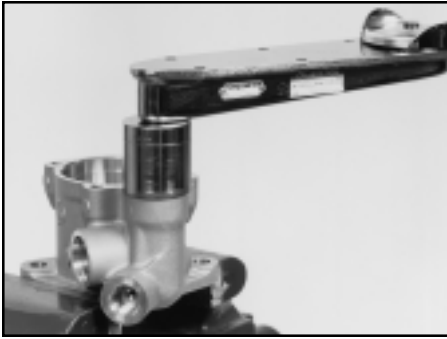

**Install plug & o-ring**

1-1/4" Socket Torque wrench

19. Lightly grease the o-ring (5) and plug (6) threads. Install into housing, and **torque to 65 ft•lb (88 N•m)**

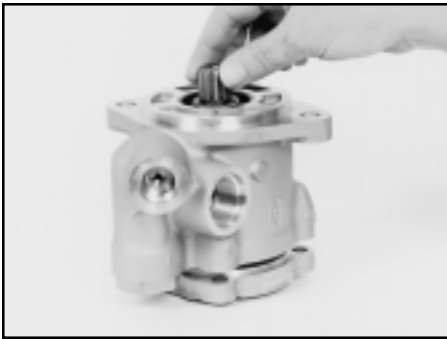

**Install housing**

20. Place the housing (1) over the rotating group assembly. Make sure the orientation is correct by matching the recessed area on the end cover with the plug. turn the input shaft to allow the housing to drop on. There will be a gap between the housing and the end cover.



**Start bolts**

21. Install the bolts (19). Thread all four bolts into the cover evenly, and tighten finger-tight.

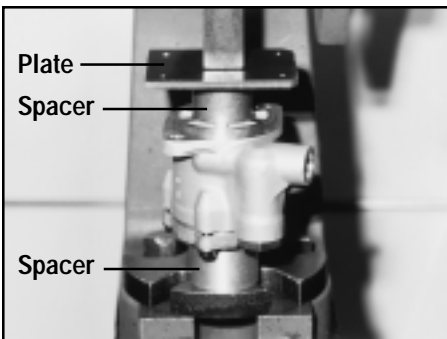

**Press housing onto end cover**

Press Spacers (or two 1-11/16" sockets) Plate

22. Take the assembly to a press. Place a spacer under the end cover to clear the bolts. Place a spacer around the input shaft, to clear the input shaft. Place a plate on top of the spacer. Press until the housing bottoms onto the end cover.



**Torque bolts**

1/2" Socket Torque wrench

23. Torque the bolts evenly, in an "X" pattern to **24 ft•lb (33 N•m)**

## **Section 4      Reinstallation**

Reinstallation .....	31
Glossary .....	32

**This page intentionally left blank.**

# Reinstallation

1. Reinstall any fittings removed prior to disassembly.
2. Position the new gasket or o-ring (whichever was removed) which will seal the pump face to the mounting surface.
3. Engage the input shaft and pilot.
4. Tighten the mounting bolts to manufacturer's specifications.
5. Unplug and reconnect the input and output lines.
6. Fill the reservoir.
7. Start the vehicle to purge the system and increase engine speed to prime the pump
8. Turn off the vehicle and check the fluid level in the reservoir. Add fluid as necessary.
9. Bleed the system, if necessary, using instructions in your steering gear service manual.

# Glossary

## Abnormal Wear

Any wear other than normal "polish marks" made by the spinning motion of the rotor and vanes. Abnormal wear would include nicks, chips, cracks and grooves.

## Burrs

Rough edges or ridges left on metal by cutting or drilling.

## Corrosion

Gradual wearing away by rust or chemical action.

## Cracks

breaks or splits in the surface.

## Damaged Splines

Cracked, broken or chipped splines on the input shaft.

## Displacement

Volume of output fluid transferred through the pump.

## Drain Hole

Excess fluid from lubricating the seal is diverted internally in the pump housing back to the inlet of the pumping element via the drain holes located in the cover and housing.

## Erosion

Gradual wearing away or deteriorating.

## Full Turn

Axle contacts axle stop

## Grooves

A long, narrow furrow cut in a surface.

## Input Port

Opening in the pump through which fluid is received from the reservoir. (Suction port).

## Manual Bleed Systems

Gears are mounted in such a way that an air pocket could form in one end of the steering gear. The bleed screw is positioned so trapped air can be forced out when loosened.

## Nicks

Small cuts, indentations or chips on the edge or surface.

## OSHA

Occupational Safety and Health Administration

## Output Port

Opening in the pump through which fluid is forced to the steering gear. (Pressure port).

## Relief Valve

Limits maximum supply pressure

## Subassembly

An assembled unit that fits into a larger unit

## Stripped Threads

Broken or damaged threads.

## Surface Imperfections

Blemish on a machined surface.

PE08-009  
FREIGHTLINER  
7/2/2008  
ATTACHMENT  
15 DRAFT



**TRW Automotive**  
Commercial Steering Systems  
800 Heath Street  
Lafayette, IN 47904  
Tel 765.423.5377  
Fax 765.429.1868  
<http://www.trucksteering.com>  
<http://trucksteering.trw.com>

© TRW Inc. 2002

TRW1313 Rev. 4/02

Response to Question 15

15. Furnish Freightliners assessment of the alleged defect in the subject vehicles, including:
- a. An assessment of the failure mechanism including all causal or contributory factors;
  - b. An assessment of the design factors of the subject component that may influence the durability of the subject component;
  - c. An assessment of the manufacturing factors that may influence the durability of the subject component;
  - d. An assessment of the vehicle assembly factors that may influence the durability of the subject component;
  - e. An assessment of the use factors of the subject component that may influence the durability of the subject component.
  - f. Please be as specific as possible in your answers and provide engineering explanations for how various factors affect the power steering pumps durability;
  - g. Any warning symptoms that the power steering pump is failing;
  - h. The root cause of the failures;
  - i. Its potential effect on occupant safety;
  - j. The potential for future occurrences of the alleged defect in the subject vehicles:

15. Response

a. Our assessment is progressive wear of the spool valve over time may affect the power steering pump performance and results in a gradual loss in "speed of steer" at low engine speeds. Speed of steer is the capability of the pump and hydraulic power steering system to keep up with the speed of steering wheel rotation by the driver. The speed of steering input is greatest at low speed.

b. The power steering pump manufacturer changed the design and coating of the spool valve to respond to reports from customers and improve the rate of wear. Freightliner Service Bulletin 46-38 provided information to diagnose, repair, and update TRW power steering pumps in service that were manufactured prior to January 1, 2005.

c. Freightliner manufacturing processes do not affect the power steering pump.

d. Freightliner vehicle assembly processes do not affect the power steering pump.

e. Use factors that can influence durability of the pump include maintenance of the power steering system, proper fluid, contamination, temperature, and duty cycle. The pump is installed on the engine and gear driven by the front engine accessory drive. The direct drive ensures the pump will always function even at reduced levels due to wear. It is not dependant on a drive belt to operate.

f. Please see the attached TRW EV Series Power Steering Pump Service Manual.

g. Over time, as the spool valve wears, the driver will notice a gradual increase in steering effort at low speeds during parking or docking maneuvers. The increase in steering effort due to wear takes time to develop dependant on duty cycle.

h. The root cause is progressive wear over time of the power steering spool valve which regulates a constant flow rate to the steering gear. A worn spool valve will bleed off more flow to the gear and reduce assist.

i. Progressive wear of the power steering pump is normal and does not affect motor vehicle safety. The gradual increase in steering effort at low speeds will be noticed by the driver and repairs can be completed. Power steering assist for speed of steer is not needed with the small steering wheel rotation angles that are used when a vehicle is at road speed.

The power steering pump provides hydraulic assist to the mechanical steering components that connect the steering wheel to the wheels on the road. The capability to control the vehicle is still maintained by the mechanical components of the steering system if power steering assist is lost for any reason.

j. Progressive wear that may reduce power steering assist and maintenance of power steering pumps used on motor vehicles ranging from passenger cars to heavy trucks is normal.