



# ODI RESUME

U.S. Department  
of Transportation  
**National Highway  
Traffic Safety  
Administration**

Investigation: PE 08-009  
Date Opened: 02/01/2008  
Principal Investigator: Bruce York  
Subject: Power Steering Pump Failures  
Date Closed: 07/03/2008

Manufacturer: Freightliner LLC  
Products: 2004 thru 2005 MY Freightliner Century and X-Line Models  
Population: 47,115

Problem Description: The subject vehicles may experience a power steering pump failure resulting in reduced steering assist. The reduction in steering assist may result in difficulty controlling the vehicle.

## FAILURE REPORT SUMMARY

	ODI	Manufacturer	Total
Complaints:	0	84	84
Crashes/Fires:	0	0	0
Injury Incidents:	0	0	0
# Injuries:	0	0	0
Fatality Incidents:	0	0	0
# Fatalities:	0	0	0
Other*:	0	0	0
	Confidential	Confidential	Confidential

\*Description of Other: Warranty claims.

Action: This Preliminary Evaluation has been closed.

Engineer: Bruce York

Date: 07/03/2008

Div. Chief: Richard Boyd

Date: 07/03/2008

Office Dir.: Kathleen C. DeMeter

Date: 07/03/2008

Summary: ODI's investigation of the subject power steering pump has found that, with over five years of operational exposure, there have been no pump failures that resulted in loss of power steering assist while the vehicle was being driven on the road or any sudden drop off in the power steering assist at any time. There are no crashes or injuries. These "reduction in assist events" have only occurred during backing or parking maneuvers.

Continue on page 2

Freightliner and TRW appear to have acted responsibly in providing information to customers and dealers regarding safe maintenance and repair procedures for power steering pumps that have experienced a reduction in "speed of steer." freightliner's field service bulletin, FSB 46-38, is a diagnostic procedure for determining if the TRW power steering pump is responsible for reduced power assist and describes corrective actions that should be taken once the determination is made. The corrective actions are: replace the spool valve assembly (vehicles built prior to 1/1/05) or, replace the power steering pump (vehicles built after 1/1/05).

A SAFETY-related defect trend has not been identified at this time and further use of agency resources does not appear to be warranted. The closing of this investigation does not constitute a finding by NHTSA that no safety-related defect exists. The agency reserves the right to take further action if warranted by the circumstances.

For more detailed information see document file.

## PRELIMINARY EVALUATION CLOSING REPORT

**SUBJECT:** 2004 through 2005 Freightliner Century and X-Line TRW Power Steering Pumps

**PE No.:** 08-009

**Date Opened:** 01-Feb-08

**Date Closed:** 03-Jul-08

**BASIS:** Early Warning Reporting aggregate data submitted to NHTSA by Freightliner suggested that a steering (EWR Code 01) problem existed for the 2004 and 2005 Century and X-Line class vehicles

**THE ALLEGED DEFECT:** Reduced power assist as a result of a failing TRW power steering pump.

**VEHICLE POPULATION:** 47,115 Vehicles

**DESCRIPTION OF COMPONENT:** This power steering systems works by using hydraulic pressure to assist in steering the vehicle's front wheels. The hydraulic pressure is provided by a power steering pump (Figure 1.) driven by the vehicle's engine. A double-acting hydraulic cylinder applies a force to the steering mechanism, which in turn applies a torque to the wheels. The flow to the cylinder is controlled by valves operated by the steering wheel. The pump is a positive displacement type and the flow rate is directly proportional to the speed of the engine. At high engine speeds the pump operates faster than at low engine speeds. To control hydraulic pressure at high engine speeds, a restricting orifice and flow control valve (Figure 1. Spool Valve) direct some of the pump's output back to the hydraulic reservoir. A pressure relief valve is also used to prevent a dangerous build-up of pressure when the hydraulic cylinder's piston reaches the end of the cylinder. The subject Freightliner vehicles use a TRW power steering pump.

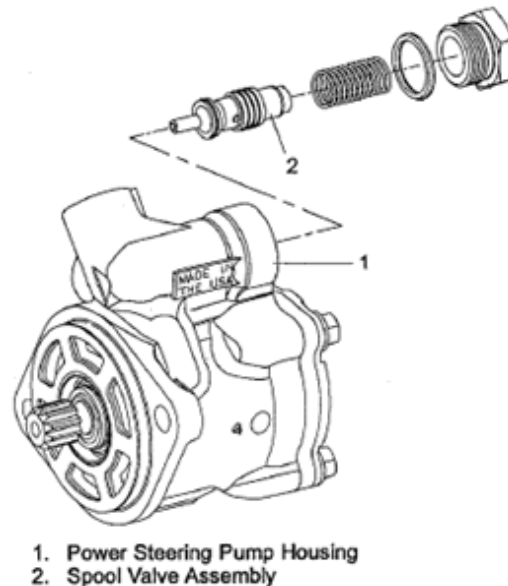

Figure 1. Power Steering Pump

**SERVICE BULLETINS:** A Field Service Bulletin (FSB) FSB 46-38 released by Freightliner in November 2005 describes how the subject vehicles may experience reduced power assist as a result of a failed power steering pump. If the power steering pump fails a diagnostic procedure, the FSB instructs the repair technician to either install a new spool valve or replace the entire pump depending on the date of pump manufacture. This FSB was later updated in June 2006 with a corrected diagnostic procedure and revised title.

**FAILURE MODES:** Field Service Bulletin FSB 46-38 released by Freightliner provides repair procedures to be followed by service technicians when a driver or owner reports an increase in steering effort on a subject vehicle equipped with a TRW power steering pump. This FSB instructs that the spool valve or the entire pump should be replaced if the pump fails to pass a diagnostic test. TRW has described the specific failure mode as a gradual reduction in the “speed of steer” in a hydraulic powered steering system caused by the progressive wearing of the power steering pump flow control valve spool. TRW further explained:

*This valve maintains a relatively constant oil flow rate to the steering gear regardless of the engine speed. The “speed of steer” is the speed at which the steering wheel can be rotated with power assist. The speed of steer is limited by the oil flow rate from the power steering pump. The oil flow rate to the steering gear may be reduced if the flow control valve begins to wear. The vehicle still has power assist but the maximum rotational speed of the steering wheel gradually slows as the flow control valve spool wears over time. This gradual loss of speed of steer is evidenced by a noticeable degrading of assist during parking maneuvers when drivers experience much higher rates of steering wheel rotation than they do at highway speeds.*

**WARRANTY:** Analysis of Freightliner warranty data has identified 3,810 warranty claims that are potentially related to the alleged defect condition in the subject vehicles. The data indicate that the alleged defect condition has occurred at relatively high rates, with the power steering pump warranty claim frequency in excess of 8 percent for the subject vehicles. The warranty claim analysis also found that approximately 1.5 percent of the warranty claims were for a condition Freightliner calls “lack of prime.” A “lack of prime” event occurs at start up of the vehicle; the power steering pump does not prime itself and the steering locks up all together. This condition is evident to the operator immediately at start up from a parked position. If the vehicle is turned off and then re-started the “lack of prime” condition is eliminated. ODI did not find any case where the “lack of prime” condition affected a vehicle that was not parked.

**STATUS:**

<u>Problem Experience</u>	<u>ODI</u>	<u>MFR</u>	<u>Total</u>
<u>Owner Reports</u>	0	64	64
<u>Field Reports</u>	NA	20	20
<u>Warranty Claims</u>	NA	3810	3810
<u>Collision Incidents</u>	0	0	0
<u>Injury Incidents</u>	0	0	0
<u>Fatal Incidents</u>	0	0	0

**CORRESPONDENCE:** On February 25, 2008, NHTSA mailed an information request to TRW and on February 27, 2008 mailed an information request to Freightliner. TRW responded by letter dated April 15, 2008 and Freightliner partially responded by e-mail dated May 14, 2008.

**WARNING SYMPTOMS:** Reduction in “speed of steer” is evidenced by a noticeable degrading of assist during parking maneuvers at low engine RPMs. Based on ODI interviews with complainants, the decrease in power assist has only occurred during backing maneuvers into loading docks and not while vehicles were being driven over the road. According to complainants, as soon as the engine speed is over approximately 1,100 or 1,200 RPMs there was not a reduction in assist.

**ODI ANALYSIS:** This investigation was opened based on early warning aggregate data submitted to NHTSA by Freightliner suggested that a steering (EWR Code 01) problem existed for the Model Year (MY) 2004 and 2005 Century and X-Line class vehicles. The count of warranty claims submitted for the subject vehicles in the fourth quarter of 2006 was significantly higher than for other MY 2004 and 2005 models manufactured by Freightliner.

Further review of warranty data submitted by Freightliner showed a very high failure rate of the power steering pump on the subject vehicles.

In addition to the warranty claims related to the power steering pump failures, Freightliner has also released a Technical Service Bulletin (TSB 46-38) describing an issue with TRW power steering pumps that can result in reduced power steering assist on the subject vehicles.

ODI opened this investigation to determine if power steering pump failures created a situation where the vehicle could become difficult to steer or startled the driver upon failing, thus presenting a safety risk.

Analysis of ODI and Freightliner data has identified 84 complaints and 3,810 warranty claims that are potentially related to the alleged defect condition in the subject vehicles. The data indicate that the alleged defect condition has occurred at relatively high rates, with the power steering pump warranty claim frequency in excess of 8 percent for the subject vehicles. However, analysis of the failure data shows that there have been no failures of the power steering pump while the vehicle was driving over the road and there have been no crashes or injuries resulting from a power steering pump failure in over 5 years of service. Additionally ODI found that approximately 1.5 percent of the power steering pump failures were “lack of prime” events where the vehicle’s steering would lock up at start up of the vehicle. In these cases, the operator could not drive the vehicle from a parked position and so were not in danger of a crash.

Detailed discussions with three large fleet operators, whose warranty claims make up approximately 1/3 of the total warranty claims reported to Freightliner, found that the TRW power steering pump failures have only occurred while the engine was at idle speed. No fleets experienced a reduction in power assist while the vehicles were on the road. In no case did a sudden decrease in power assist ever occur. The decrease in assist was always a slow progressive failure. The fleets all reported that the failures they had experienced occurred while the vehicle was being backed into a loading dock. The description of these events corroborated the failure mode as described by TRW. Additionally these three fleets all reported that the number of claims for TRW power steering pump failures had dropped off significantly over a year ago.

**REASON FOR CLOSING:** ODI has not found evidence of a possible safety-defect trend.

With over five years of operational exposure, ODI is not aware of any pump failures that resulted in loss of power steering assist while the vehicle was being driven on the road or where there was a sudden drop off in the power steering assist. These reduction in assist events have only occurred during start-up, backing or parking maneuvers. In issuing FSB 46-38, Freightliner and TRW appear to have acted responsibly in providing information to customers and dealers regarding safe maintenance and repair procedures for power steering pumps that have experienced a reduction in “speed of steer.” In light of these findings, a safety-related defect trend has not been identified at this time and further use of agency resources does not appear to be warranted. The closing of this investigation does not constitute a finding by NHTSA that no safety-related defect exists. The agency reserves the right to take further action if warranted by the circumstances.