

**PE07-012**  
**FREIGHTLINER**  
**4/20/2007**  
**ATTACHMENT**  
**PART 3 OF 7**

## Front Door Removal and Installation

### Removal

1. Shut down the engine, apply the parking brakes, and chock the tires.
2. Remove the motor assembly access cover mounting screws. Remove the access cover.
3. If equipped with air-operated doors, remove the air filter. See **Subject 120** for instructions.
4. If equipped with air-operated doors, remove the pneumatic actuator assembly. See **Subject 110** for instructions.
5. If equipped with electrically operated doors, remove the electric actuator assembly. See **Subject 130** for instructions.
6. Remove the 11 mounting screws on each door that attach the door jam seal to the support post.
7. Remove the cotter pin and remove the clevis pin from the clevis that connects the door rod linkage assembly to the aft levers. See **Fig. 1**.
8. Remove the E-clip from the aft door hex shaft. Loosen the top aft lever capscrew and nut. Pry the aft lever off the hex shaft. Remove the door rod linkage assembly, nylon washer, and lever support spacer.
9. Remove the four capscrews that attach the tray assembly to the header panel.

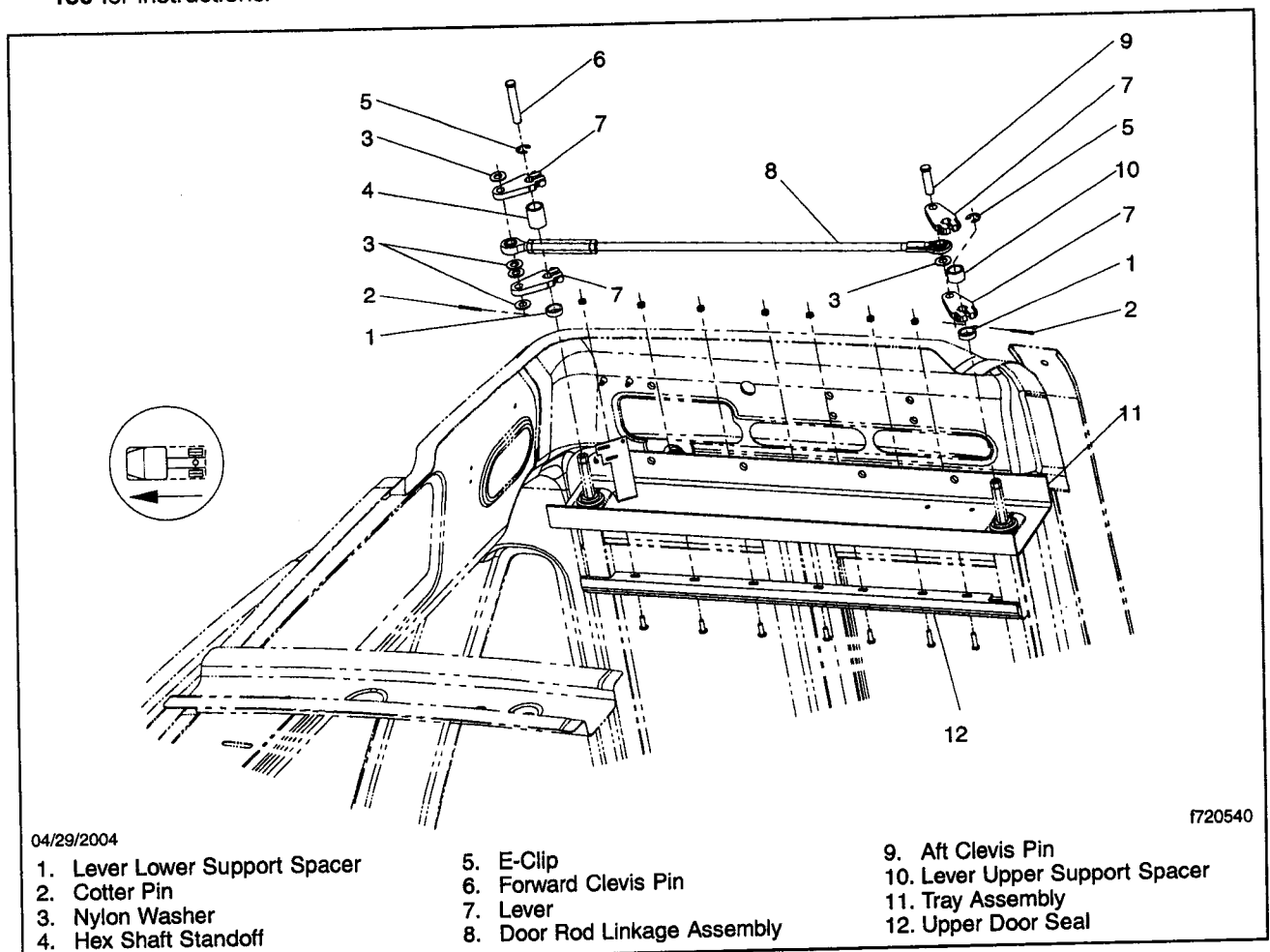

04/29/2004

1. Lever Lower Support Spacer
2. Cotter Pin
3. Nylon Washer
4. Hex Shaft Standoff

5. E-Clip
6. Forward Clevis Pin
7. Lever
8. Door Rod Linkage Assembly

9. Aft Clevis Pin
10. Lever Upper Support Spacer
11. Tray Assembly
12. Upper Door Seal

1720540

J. 1, Passenger Door Assembly

Attachment 24  
(TBB 72.00 Front Door Service.pdf )

---

## Front Door Removal and Installation

10. With the help of an assistant, lift the door assembly out of the hex shaft bearings in the stepwell. Remove the door assembly from the stepwell. Retrieve the nylon washers from between the door and hex shaft bearings.

### Installation

---

1. Place the nylon washers on top of the hex shaft bearings in the stepwell. With the help of an assistant lift the door assembly into the door stepwell. Align the hex shafts with the nylon washers and hex shaft bearings in the stepwell. Position the tray mount door support against the header panel.
2. Install the four capscrews that attach the tray mount assembly to the header panel.
3. If removed, install the two lower hex shaft levers onto the hex shafts.
4. The cam positions should match the reference angles shown in **Fig. 2**. If necessary remove the levers and install them at the proper angles. See **Fig. 2**.
5. Place the lever upper support spacer onto the aft hex shaft. Align the top aft lever with the lower aft lever. Install the top aft lever onto the hex shaft. Do not tighten at this time.
6. Place the nylon washer around the clevis pin hole on top of the lower aft lever.
7. Slide the door rod linkage assembly (non adjustable end) between the two aft levers. Install the clevis pin through the top aft lever, door rod linkage assembly, nylon washer, and bottom aft lever. Install a new cotter pin to lock the clevis pin.
8. Press the top aft lever down until it contacts the upper support spacer. Install the E-clip onto the hex shaft. Tighten the aft lever capscrew 10 lbf-ft (14 N·cm).
9. Tighten the top aft lever nut 10 lbf-ft (14 N·m).
10. With the doors closed tightly, adjust the door rod linkage assembly to align the clevis pin hole with the forward hex shaft lever.
11. Position the door jam seals against the support post. Secure the door jam seals to the support with the 11 mounting screws.
12. If equipped with electrically operated doors, install the electric motor assembly. See **Subject 130** for instructions.
13. If equipped with air-operated doors, install the pneumatic actuator assembly. See **Subject 110** for instructions.
14. If equipped with air-operated doors, install the air filter. See **Subject 120** for instructions.
15. Install and tighten the motor assembly access cover mounting screws.
16. Remove the chocks from the tires.

Front Door Removal and Installation

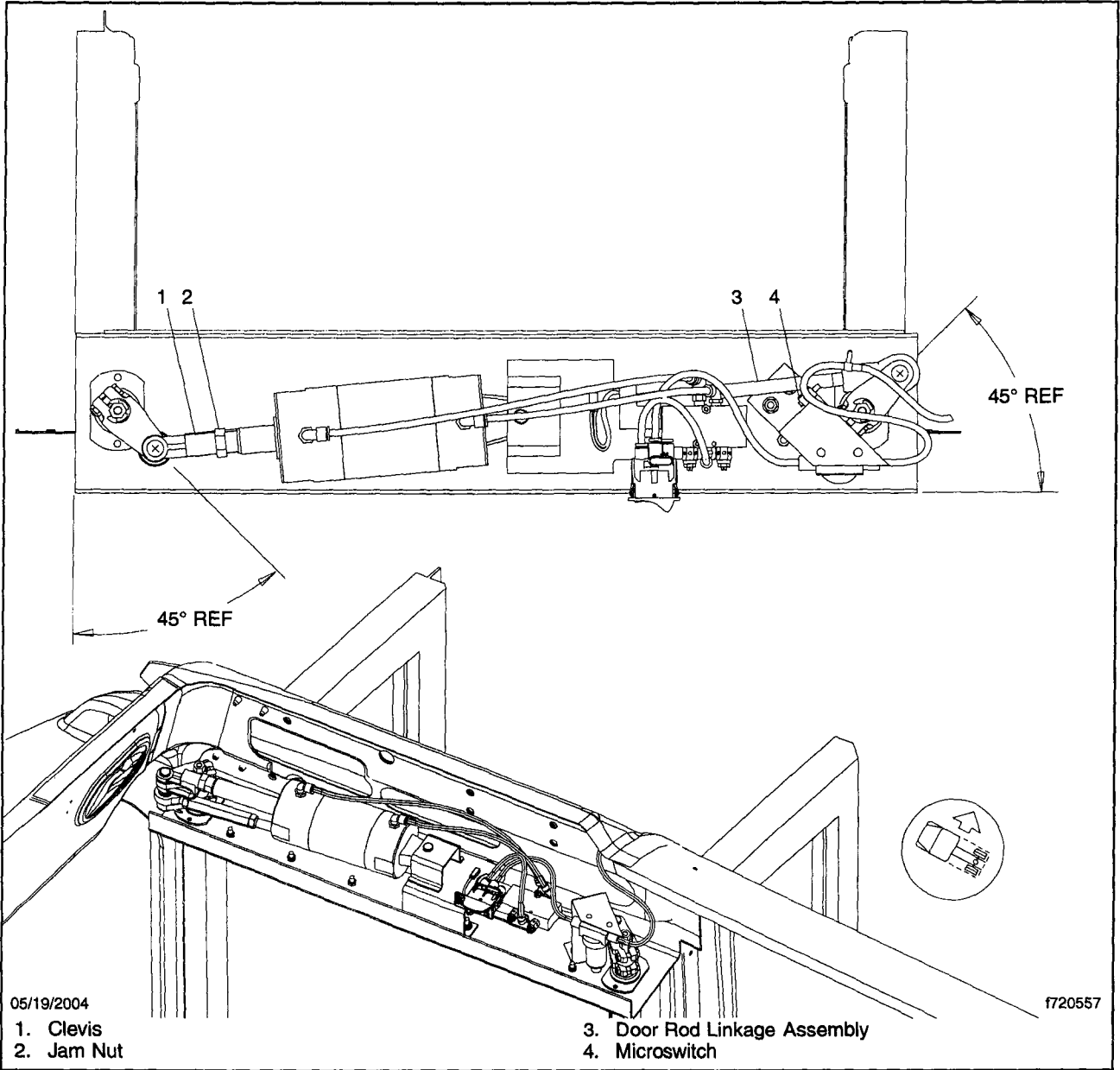

Fig. 2, Cam Positions With Doors Open (pneumatic door shown, electrical door similar)

## Pneumatic Actuator Removal and Installation

### Removal

1. Shut down the engine, apply the brakes, and chock the tires.
2. Drain the air supply.
3. Remove the pneumatic actuator assembly access cover mounting screws from the header panel above the passenger door. Lower the access cover. If equipped with a cover-mounted emergency release switch, label and disconnect the air lines from the release switch.
4. Remove the access cover.
5. Remove the air filter assembly. See **Subject 120** for instructions.
6. Disconnect the air line from the pneumatic actuator. See **Fig. 1**.
7. Remove the cotter pin from the forward hex shaft lever clevis pin. Note the position of the nylon washers for assembly reference. Remove the clevis pin and nylon washers from the actuator assembly clevis, forward hex shaft lever, and door rod linkage assembly.
8. Remove the four capscrews, flatwashers, and nuts that attach the pneumatic actuator mounting bracket to the tray mount. Remove the pneumatic actuator assembly from the bus.

6. Position the pneumatic actuator assembly access cover on the header panel above the passenger door.
7. If equipped with a cover-mounted emergency release switch, connect the air lines to the release switch.

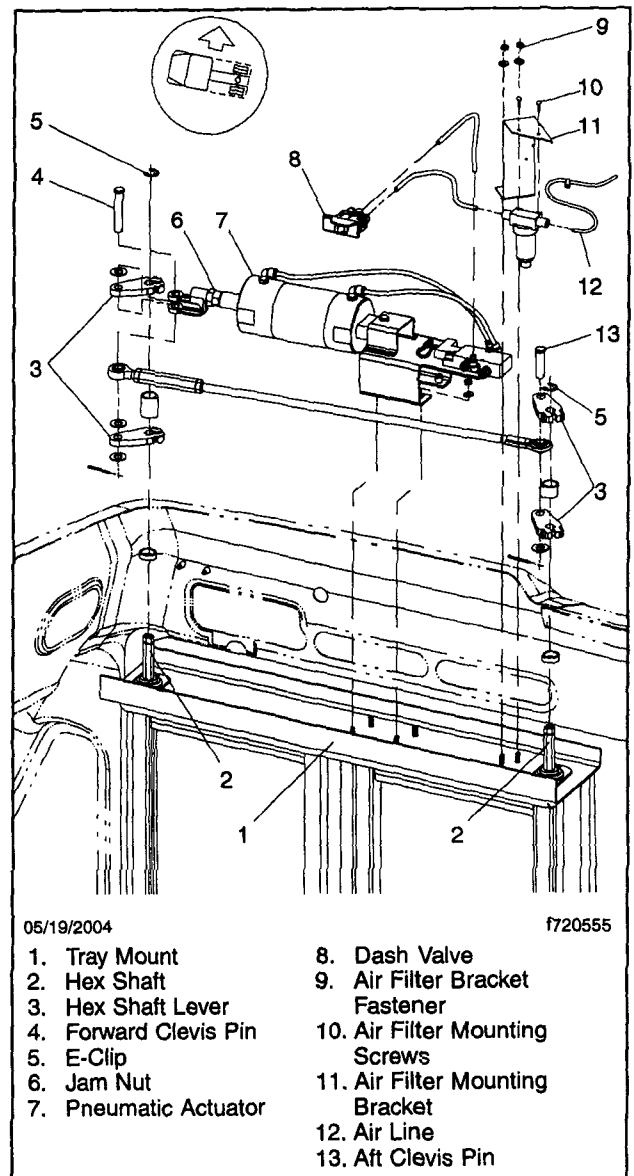

05/19/2004

f720555

- |                       |                                 |
|-----------------------|---------------------------------|
| 1. Tray Mount         | 8. Dash Valve                   |
| 2. Hex Shaft          | 9. Air Filter Bracket Fastener  |
| 3. Hex Shaft Lever    | 10. Air Filter Mounting Screws  |
| 4. Forward Clevis Pin | 11. Air Filter Mounting Bracket |
| 5. E-Clip             | 12. Air Line                    |
| 6. Jam Nut            | 13. Aft Clevis Pin              |
| 7. Pneumatic Actuator |                                 |

**Fig. 1, Pneumatic Actuator Assembly**

### Installation

1. Place the pneumatic actuator assembly on the tray mount. Align the pneumatic actuator assembly with the four mounting holes. Install the mounting capscrews, washers, and nuts.
2. Slide the actuator assembly clevis onto the forward hex shaft lever. Insert the nylon washers in the correct position. Align and insert the clevis pin through the nylon washers, actuator assembly clevis, forward hex shaft lever, and door rod linkage assembly. Install a new cotter pin.
3. Connect the air line to the pneumatic actuator.
4. Install the air filter assembly. See **Subject 120** for instructions.
5. Adjust the door linkage. See **Subject 140** for instructions.

## **Pneumatic Actuator Removal and Installation**

8. Install and tighten the access cover with self-tapping screws.
9. Remove the chocks from the tires.

## Air Filter Removal and Installation

### Removal

1. Shut down the engine, apply the brakes, and chock the tires.
2. Drain the air supply.
3. Remove the pneumatic actuator assembly access cover mounting screws from the header panel above the passenger door. Lower the access cover. If equipped with a cover-mounted emergency release switch, label and disconnect the air lines from the release switch.
4. Remove the access cover.
5. Disconnect the wire harness electrical connector from the microswitch.
6. Disconnect the air lines from the air filter. See Fig. 1.
7. Remove the two capscrews, nuts, and washers that attach the air filter bracket to the tray. Remove the air filter and bracket assembly. See Fig. 2.

### Installation

1. Place the air filter and bracket assembly on the tray mount assembly. Attach the bracket to the tray mount using two capscrews, washers, and nuts.
2. Connect the air lines to the air filter.
3. Connect the wire harness connector to the microswitch.
4. Position the pneumatic actuator assembly access cover on the header panel above the passenger door.
5. If equipped with a cover-mounted emergency release switch, connect the air lines to the release switch.
6. Install and secure the access cover with self-tapping screws.
7. Remove the chocks from the tires.

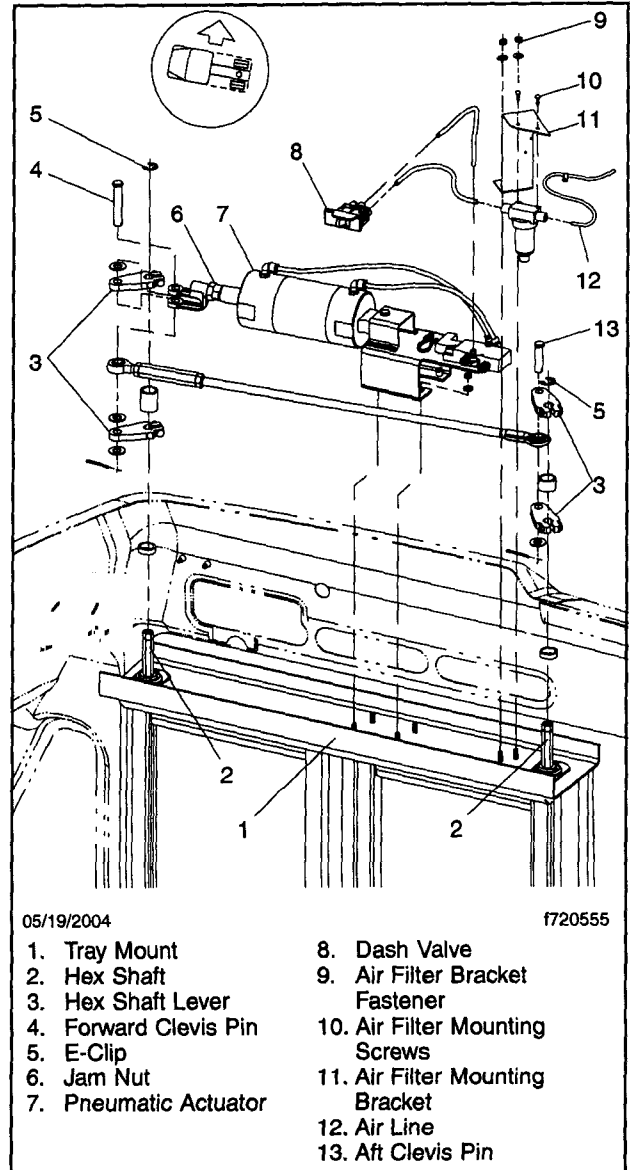

Fig. 1, Pneumatic Door Components

## Air Filter Removal and Installation

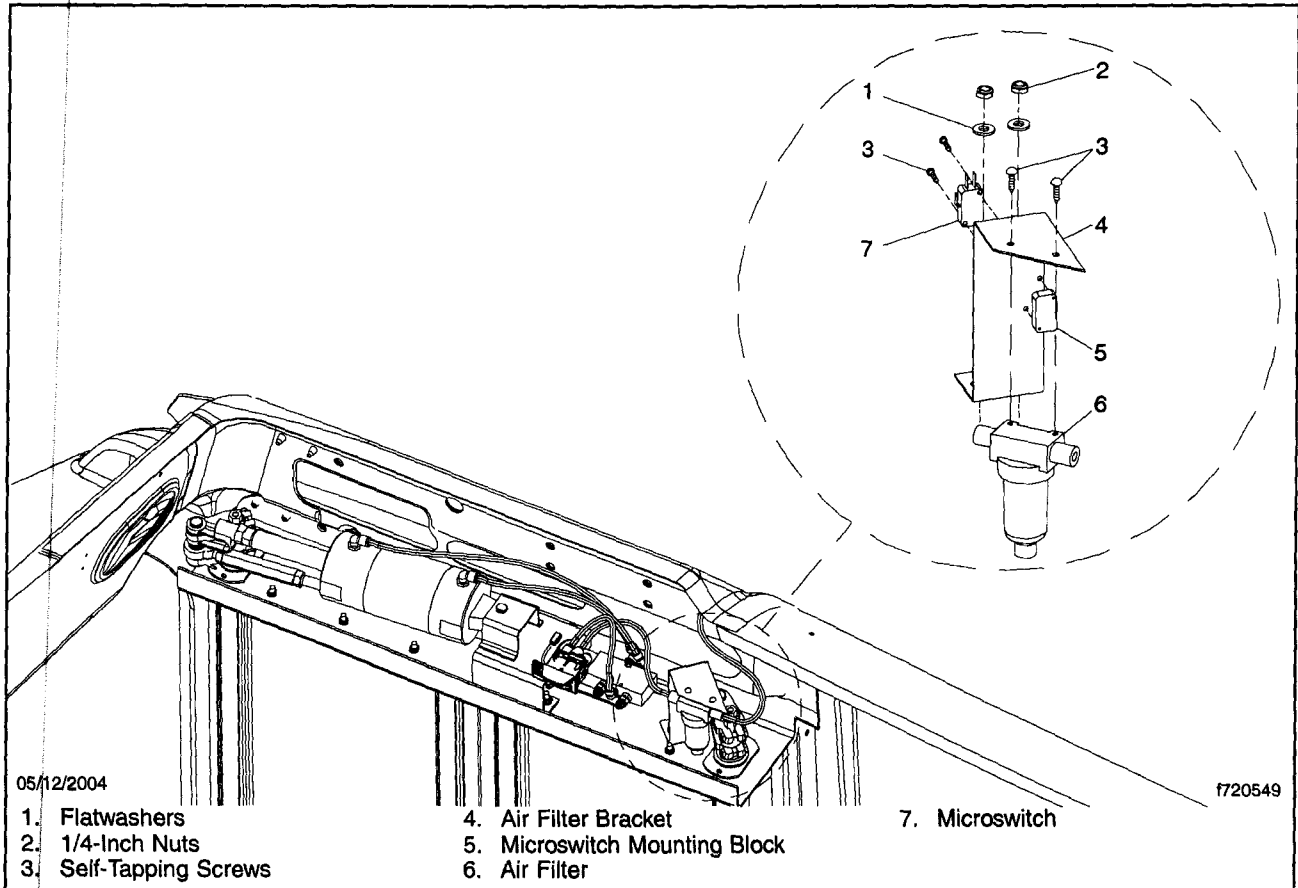

Fig. 2, Air Filter

## Electrical Actuator Assembly Removal and Installation

### Removal

1. Shut down the engine, apply the brakes, and chock the tires.
2. Remove the screw that fastens the emergency release handle to the handle stem that passes through the actuator assembly access cover. Remove the handle.
3. Remove the actuator assembly access cover mounting screws from the header panel above the passenger door. Remove the access cover.
4. Remove the clips and screws that connect the emergency release cable to the header panel and release lever. See Fig. 1.

## Electrical Actuator Assembly Removal and Installation

5. Disconnect the wire harness electrical connectors from the actuator and two microswitches.
6. Remove the cotter pin from the front hex shaft lever clevis pin. Note the position of the nylon washers for assembly reference. Remove the clevis pin and nylon washers from the actuator assembly
7. Remove the four capscrews, flatwashers, and nuts that attach the actuator assembly mounting bracket to the tray assembly. Remove the actuator assembly from the bus.

clevis, forward hex shaft lever, and door rod linkage assembly.

7. Remove the four capscrews, flatwashers, and nuts that attach the actuator assembly mounting bracket to the tray assembly. Remove the actuator assembly from the bus.

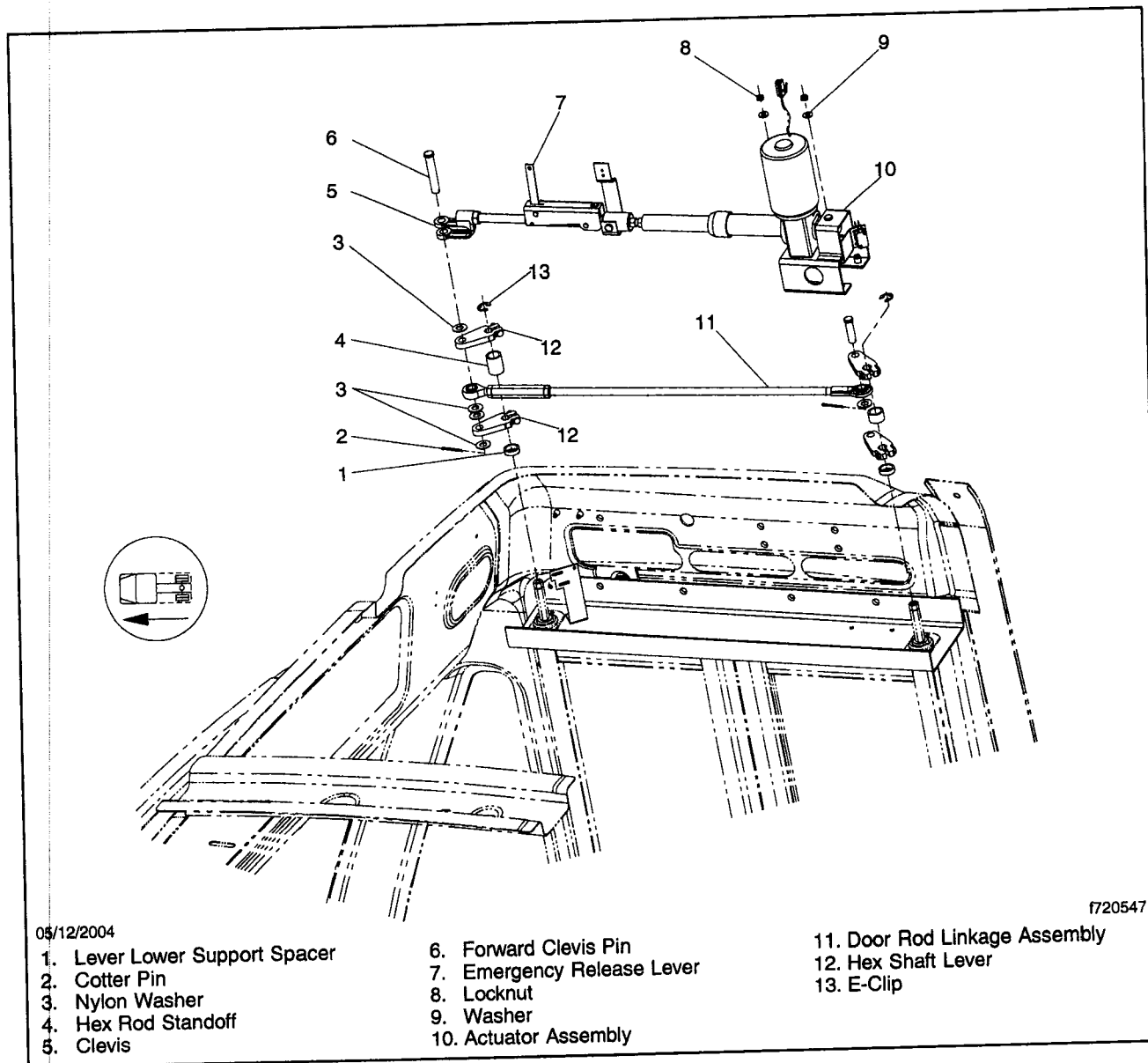

f720547

05/12/2004

1. Lever Lower Support Spacer
2. Cotter Pin
3. Nylon Washer
4. Hex Rod Standoff
5. Clevis

6. Forward Clevis Pin
7. Emergency Release Lever
8. Locknut
9. Washer
10. Actuator Assembly

11. Door Rod Linkage Assembly
12. Hex Shaft Lever
13. E-Clip

**Fig. 1, Electrical Actuator Assembly**

---

**Electrical Actuator Assembly Removal and Installation**

---

**Installation**

---

1. Place the actuator assembly on the tray assembly. Align the actuator mounting bracket with the tray assembly mounting holes. Install the mounting capscrews, washers, and tighten the nuts.
2. Slide the actuator assembly clevis onto the forward hex shaft lever. Insert the nylon washers in the correct position. Align and insert the clevis pin through the nylon washers, actuator assembly clevis, front hex shaft lever, and door rod linkage assembly. Install a new cotter pin.
3. Connect the wire harness connectors to the actuator and two microswitches.
4. Adjust the door linkage. See **Subject 140** for instructions.
5. Route the emergency brake cable to the emergency release lever.
6. Install the clips and screws that connect the emergency release cable to the header panel and release lever.
7. Position the actuator assembly access cover on the header panel above the passenger door. Secure the cover with self-tapping screws.
8. Install the emergency release handle, and, with the retaining screw, secure it to the handle stem that passes through the actuator assembly access cover.
9. Remove the chocks from the tires.

### Pneumatic Actuator Assembly

1. Shut down the engine, apply the brakes, and chock the tires.
2. Drain the air supply.
3. Remove the pneumatic actuator assembly access cover mounting screws from the header panel above the passenger door. Lower the access cover. If equipped with a cover-mounted emergency release switch, label and disconnect the air lines from the release switch.
4. Remove the access cover.
5. Remove the cotter pin from the front hex rod lever clevis pin. Note the position of the nylon washers for assembly reference. Remove the clevis pin and nylon washers from the actuator assembly clevis, front hex shaft lever, and door rod linkage assembly. See Fig. 1.
6. Place the doors in the fully retracted position. Slide the door rod linkage assembly over the lower front hex shaft lever. Loosen the door rod linkage assembly jam nut. See Fig. 2.
7. Adjust the door rod linkage assembly to align with the hex shaft lever clevis pin hole. Temporarily install the clevis pin. Adjust the door rod linkage until there is light pressure on the door edge seals. Tighten the jam nut.
8. Remove the clevis pin.
9. Slide the actuator assembly clevis over the front upper hex rod lever. Align the clevis with the hex shaft lever clevis pin hole.
10. Insert the nylon washers in the correct position. Align and insert the clevis pin through the nylon washers, actuator assembly clevis, front hex shaft levers, and door rod linkage assembly. Install a new cotter pin.
11. Loosen the pneumatic actuator clevis jam nut.
12. Extend and retract the doors. Observe the door operation.
13. Adjust the actuator connection to provide full extension of the actuator in both directions.
14. Tighten the jam nut.

15. Position the pneumatic actuator assembly access cover on the header panel above the passenger door.
16. If equipped with a cover-mounted emergency release switch, connect the air lines to the release switch.
17. Install the access cover with self-tapping screws.

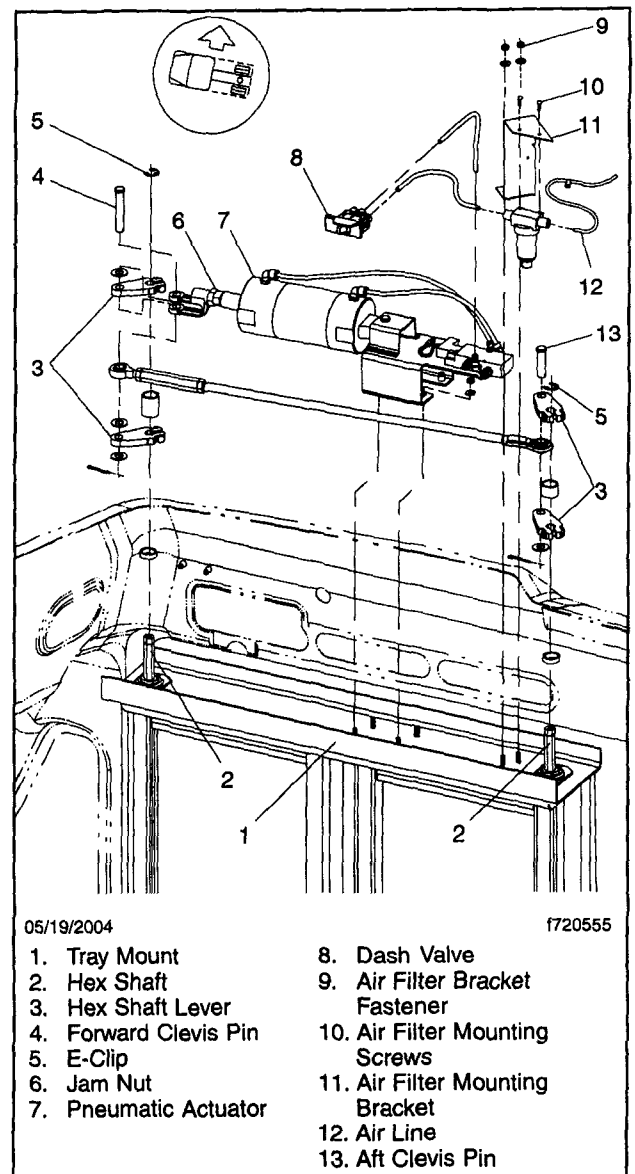
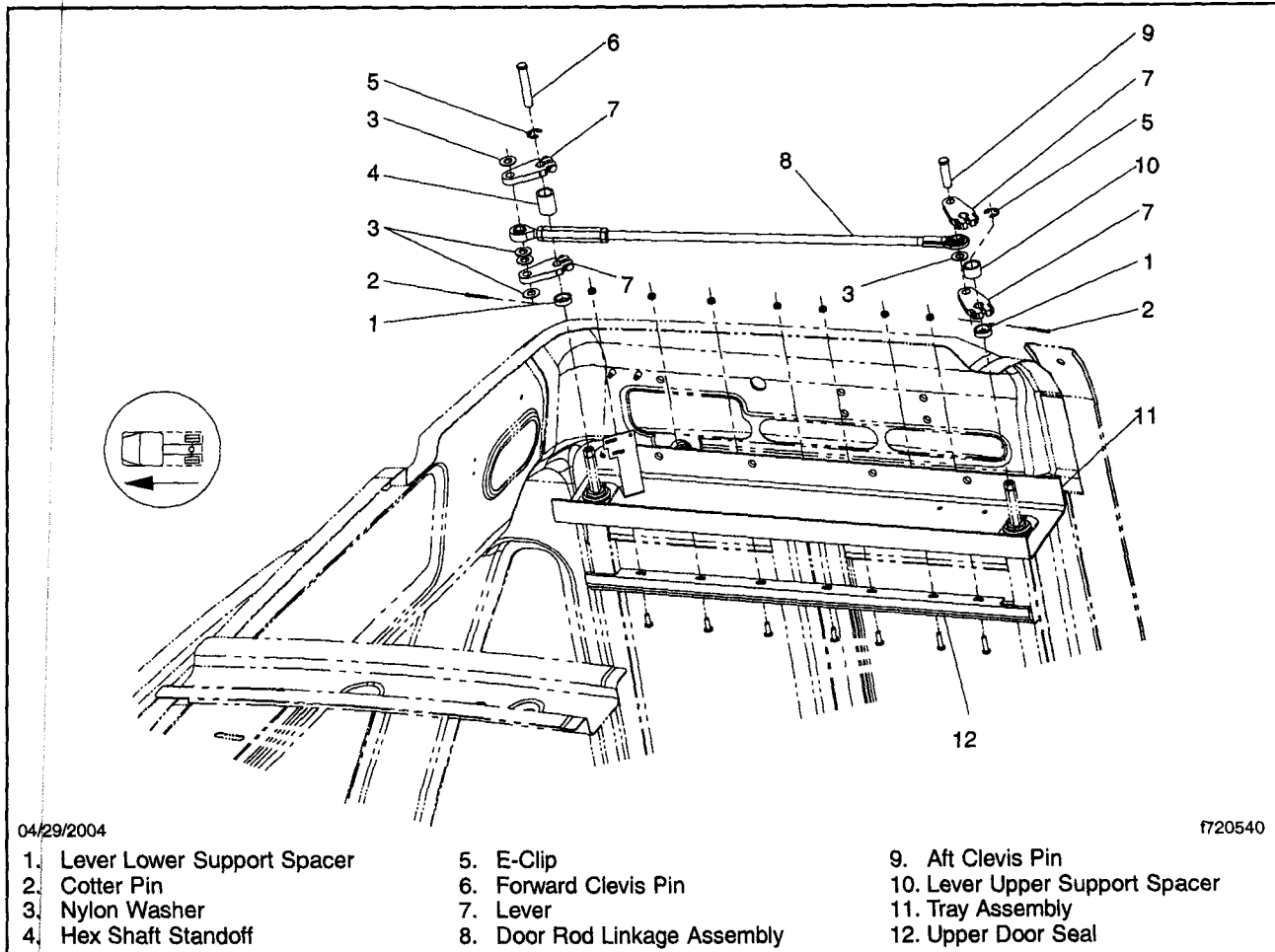

Fig. 1, Pneumatic Door Components

## Door Adjustment



**Fig. 2, Door Rod Linkage**

18. Remove the chocks from the tires.

### Electric Actuator Assembly

1. Shut down the engine, apply the brakes, and chock the tires.
2. Remove the screw that fastens the emergency release handle to the handle stem that passes through the actuator assembly access cover. Remove the handle.
3. Remove the actuator assembly access cover mounting screws from the header panel above the passenger door.

4. Remove the access cover.

5. Remove the clips and screws that connect the emergency release cable to the header panel and release lever.
6. Remove the cotter pin from the front hex shaft lever clevis pin. Note the position of the nylon washers for assembly reference. Remove the clevis pin and nylon washers from the actuator assembly clevis, front hex shaft lever, and door rod linkage assembly. See **Fig. 3**.
7. Place the doors in the fully retracted position. Slide the door rod linkage assembly over the front lower hex shaft lever. Loosen the door rod linkage assembly jam nut.

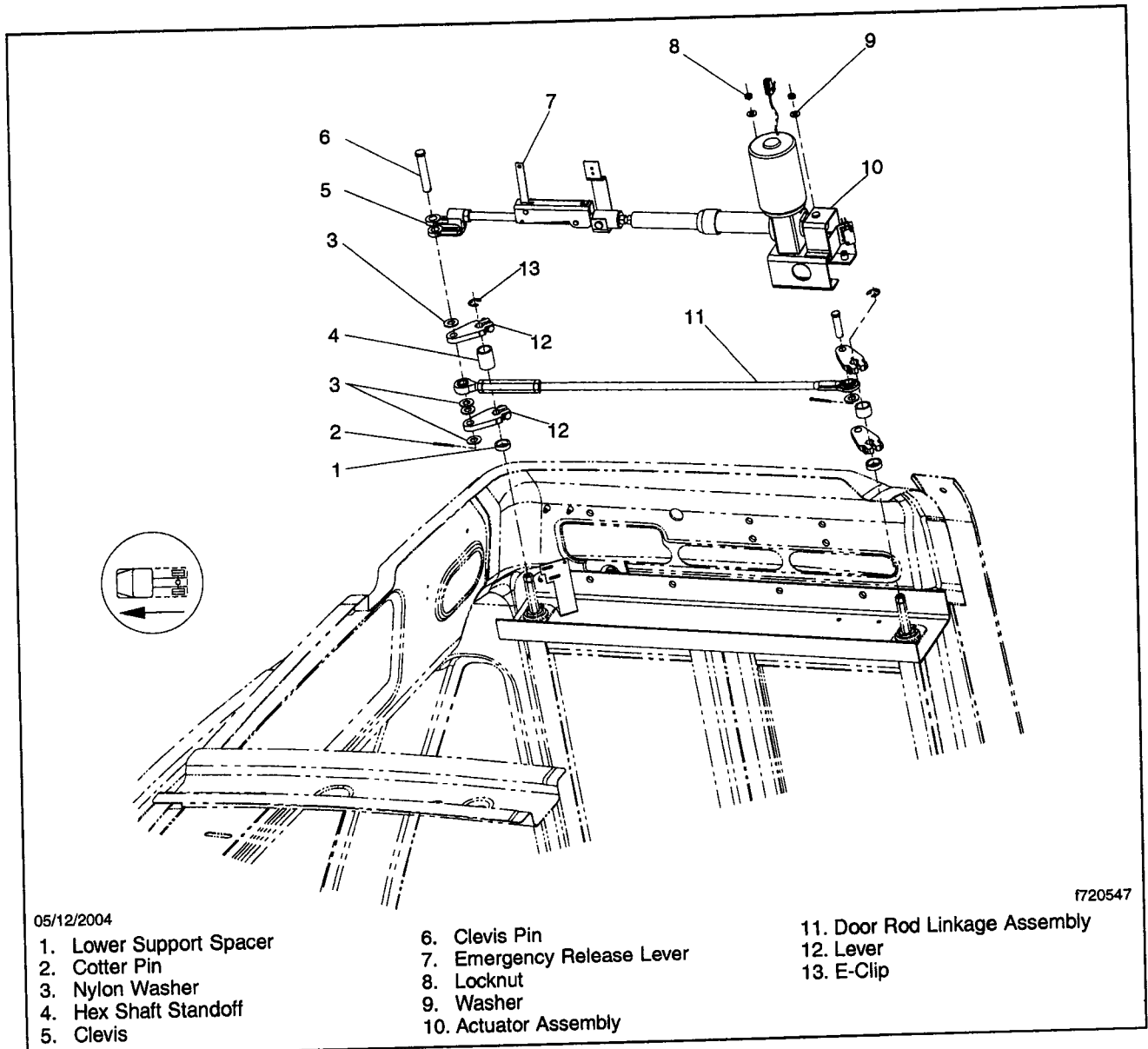

**Fig. 3, Electrical Door Components**

8. Adjust the door rod linkage assembly to align with the front lower hex shaft lever clevis pin hole. Temporarily install the clevis pin. Adjust the door rod linkage until there is light pressure on the door edge seals. Tighten the jam nut. See Fig. 4.
9. Remove the clevis pin.
10. Slide the actuator assembly clevis over the upper front hex shaft lever. Align the clevis with the hex shaft lever clevis pin hole.
11. Insert the nylon washers in the correct position. Align and insert the clevis pin through the nylon washers, actuator assembly clevis, front hex shaft levers, and door rod linkage assembly. Install a new cotter pin.

## Door Adjustment

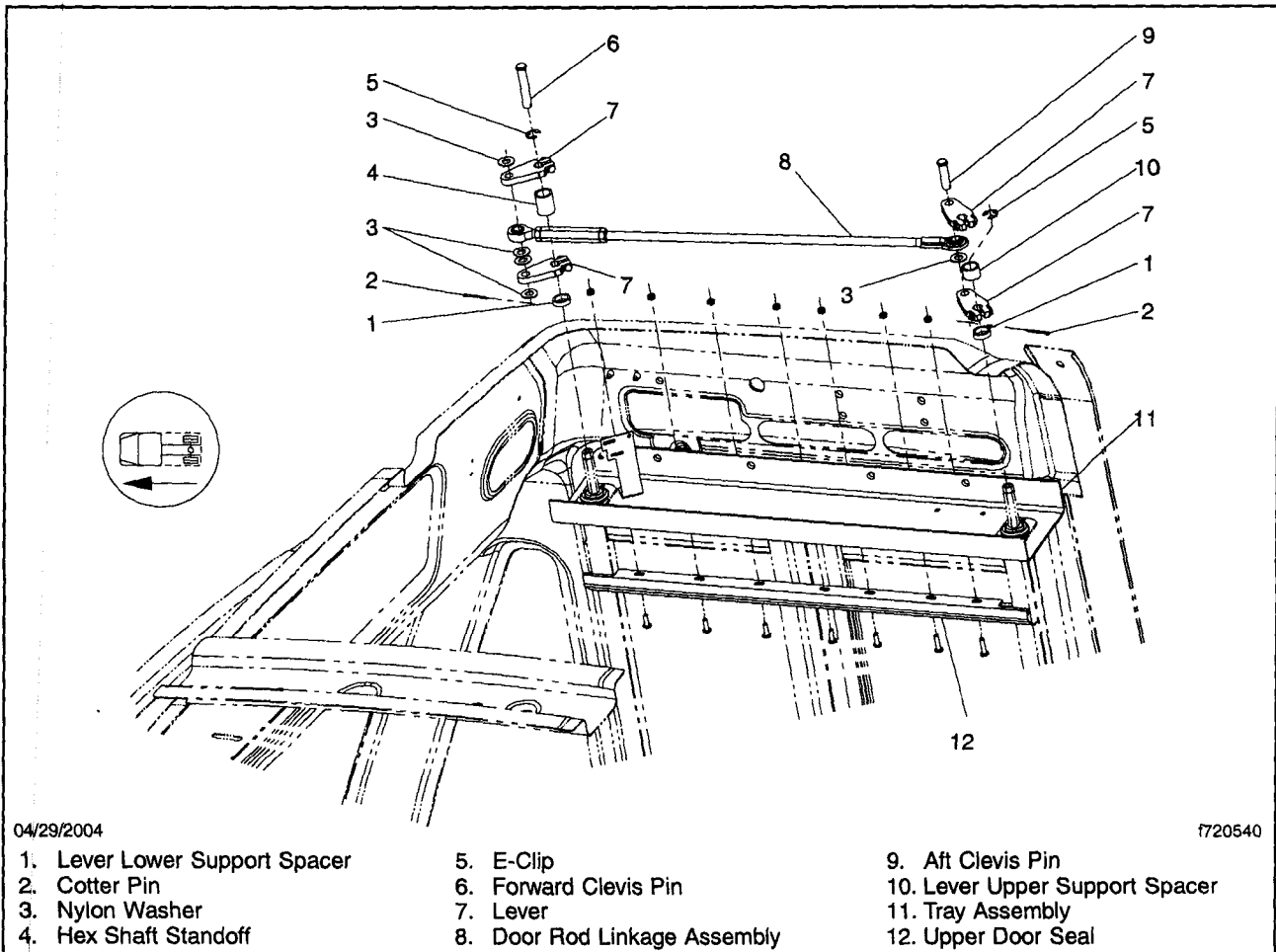

**Fig. 4, Door Rod Linkage**

12. Loosen the actuator clevis jam nut.
13. Extend and retract the doors. Observe the door operation.
14. Adjust the actuator connection to provide full extension of the actuator in both directions.
15. Tighten the jam nut.
16. Route the emergency brake cable to the emergency release lever.
17. Install the clips and screws that connect the emergency release cable to the header panel and release lever.
18. Position the actuator assembly access cover on the header panel above the passenger door. Install and secure the access cover with self-tapping screws.
19. Remove the chocks from the tires.

## General Information

The smart switch, unlike a conventional switch, requires a device to read the identification code resistors within the smart switch. The device that reads the identification code resistors is the bulkhead module. The identification code resistors indicate the function the switch controls on the vehicle (lights and actuators), as well as the position of the switch (either up, middle, or down). See Fig. 1 for examples of smart switches. Smart switches also require drive for the status indicator (on/off) of the function and the backlight function symbol.

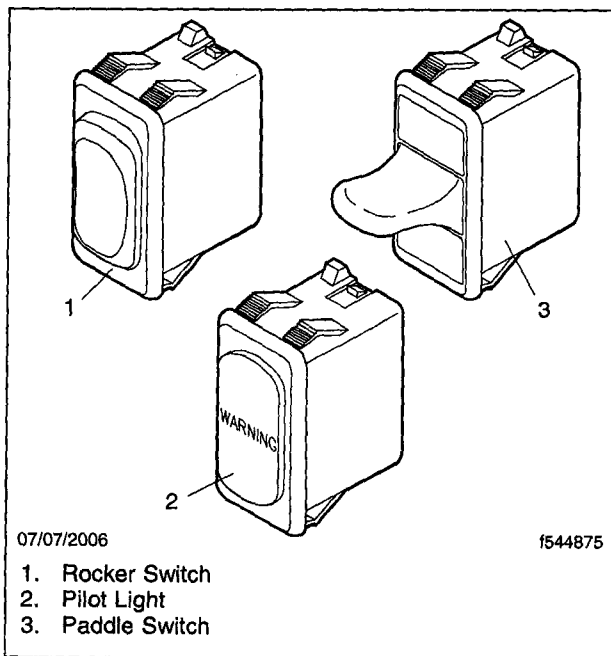

Fig. 1, Smart Switches and Pilot Light

A pilot light is similar to a smart switch in several ways. They plug into the same harnesses and modules. Pilot lights have their own unique internal identification code resistors like smart switches. However, unlike smart switches, pilot lights are only used as indicator pilot lights. There is no switching mechanism. See Fig. 1.

The Bulkhead Module (BHM) is capable of connecting with up to five smart switches through five smart switch ports. Each Switch Expansion Module (SEM) is capable of holding up to six additional smart switches with as many as four SEMs possible per

vehicle. Finally, the Switch Hub Module (SHM), with up to three Eight Switch Banks (8SB) is capable of holding up to 24 additional smart switches and/or pilot lights.

The following are some general facts about smart switch and pilot lights.

- Each smart switch/pilot light is unique, and is identified by internal resistors.
- A smart switch does not carry the electrical current for the function itself.
- A smart switch acts as an input to the BHM to tell it what position the switch is in.
- Function identification inputs—identifies itself as to what function it serves.
- Switch position input—tells the BHM what position the switch is in.
- The BHM controls the indicator light in the smart switch.
- The indicator turns on and stays on as long as the function is active.
- The indicator blinks if the BHM does not get the anticipated feedback.
- Each smart switch contains a backlighting circuit.
- A smart switch or pilot light can be plugged into any of the smart switch ports either on the BHM, the SEM, or the SHM/8SB.

Smart switches are used to control a variety of optional functions on Saf-T-Liner busses such as heated mirrors, fog lights, strobe light, warning lights, etc. Options that use a pilot light include the wheelchair lift power red and power green LEDs, post-trip inspection light, stop request pilot light, etc.

Attachment 25  
(TBB 54.16 Smart Switch Service.pdf)

## Troubleshooting

### Typical Smart Switch Problems

Smart switch problems can cause several types of symptoms or faults, and must be investigated to determine if the smart switch itself is the cause of the problem. **Table 1** lists symptoms and faults that may indicate a smart switch problem.

See the heading "Definition of Smart Switch Faults" for further explanation of each type of smart switch fault code.

Smart switch symptoms are as follows:

- Smart switch controlled function does not work
- Smart switch indicator light does not work

### Definition of Smart Switch Faults

#### Missing Smart Switch Fault

This fault indicates that the Bulkhead Module (BHM) can not detect a smart switch for a function that is programmed into the BHM by a reference parameter. For example, a fog light switch could not be detected, but a reference parameter for fog lights is programmed into the BHM.

#### Duplicate Smart Switch Fault

This fault indicates that the BHM has detected more than one smart switch for a particular function pro-

grammed into the BHM by a reference parameter. For example, two fog light smart switches are connected.

#### Extra Smart Switch Fault

This indicates that the BHM detects a smart switch for a function that is not programmed into the BHM by a reference parameter. For example, a fog light switch is connected, but the vehicle is not programmed for fog lights.

#### Smart Switch VBATT Short to Ground

This fault indicates a smart switch indicator and backlight drive overloaded. Only smart switches connected to either a Switch Expansion Module (SEM) or a Switch Hub Module/Eight Switch Banks (SHM/8SB) will report this fault.

### Determining Which Smart Switches the Vehicle is Programmed to Use

Follow the instructions below to determine which vehicle functions use a smart switch.

1. In ServiceLink, click on the BHM icon.

| Smart Switch Faults |     |     |       |      |     | Fault Description                  |
|---------------------|-----|-----|-------|------|-----|------------------------------------|
| J1587               |     |     | J1939 |      |     |                                    |
| MID                 | SID | FMI | SA    | SPN  | FMI |                                    |
| 164                 | 022 | 07  | 33    | 6918 | 07  | Missing Smart Switch               |
| 164                 | 021 | 07  | 33    | 6919 | 07  | Duplicate Smart Switch             |
| 164                 | 020 | 07  | 33    | 6920 | 07  | Extra Smart Switch                 |
| —                   | —   | —   | 49    | 6914 | 04  | Smart Switch VBATT Short to Ground |
| —                   | —   | —   | 128   | 6914 | 04  | Smart Switch VBATT Short to Ground |
| —                   | —   | —   | 129   | 6914 | 04  | Smart Switch VBATT Short to Ground |
| —                   | —   | —   | 130   | 6914 | 04  | Smart Switch VBATT Short to Ground |
| —                   | —   | —   | 131   | 6914 | 04  | Smart Switch VBATT Short to Ground |

Table 1, Smart Switch Faults

## Troubleshooting

- Click on the "Features" tab. A list of all the reference parameters that are programmed into the BHM can be seen. Functions that use a smart switch will have (smart switch) in the reference parameter description text. See Fig. 1.

In the ServiceLink example, the reference parameters which have smart switches are:

- 26-02028-007 with ID sign (smart switch)
- 26-02031-001 with driver dome lamp (smart switch)
- 26-02032-001 passenger dome lights, IGN-On/Acc, follows entrance door (smart switch)
- 26-02047-011 step well lights w/2-speed heater (smart switch)
- 26-02049-003 left side aft heater fan, 2 speed, IGN-enabled On/Acc (smart switch)
- 26-02050-007 with defroster fan on windshield heater (smart switch) and escape hatch w/buzzer

If the vehicle is equipped with an SEM, there will be a separate icon on the left-hand menu. Click this icon and a separate tab for smart switches will appear (the same applies for the SHM icon). This menu will list all smart switches connected to SEM and the SHM. Smart switches connected to the BHM will not be listed here.

## Troubleshooting Smart Switch Problems

### Missing Smart Switch Fault

This fault indicates that a smart switch the BHM is programmed to use is not connected to one of the smart switch ports. To troubleshoot this fault, determine which smart switches the vehicle is programmed to use. Use the "Features" screen in ServiceLink to determine what smart switches the vehicle should have. See the heading "Determining Which Smart Switches the Vehicle is Programmed to Use".

| Currently Installed Features   |  |
|--|--|
| Reference Parameter  | Description  |
| 26-02028-007   | With ID Sign (Smart Switch)  |
| 26-02029-000   | Not Multiplexed Utility Light  |
| 26-02031-001   | With Driver Dome Lamp (Smart Switch)   |
| 26-02032-001   | Passenger Dome Lights, IGN-On/Acc, follows Entrance Door (Smart Switch)          |
| 26-02035-017   | Warn Sys- 8 Lt Pkg 8, Amb, Red Lps, Amb, Red, Grn Plts, Emerg-Ovrd               |
| 26-02044-001   | Window Sash, IGN On/Acc, W/Bzr, Indicates a push-out window is open, Auto Trans  |
| 26-02045-002   | Door Control-Std LH Dash Sw., Air-Elec, No ext. Cntr, Bat                        |
| 26-02047-011   | Stepwell Lights w/ 2-Speed Heater (Smart Switch)                                 |
| 26-02048-001   | Not Multiplexed, HVAC  |
| 26-02049-003   | Left Side Aft Heater Fan, 2-Speed, IGN-enabled On/Acc (Smart Switch)             |
| 26-02050-007   | With Defroster Fan on Windshield Header (Smart Switch) and Escape Hatch w/Buzzer |
| 26-02051-001   | Backup Alarm, w/Left and Right Upper Backup Lamps                                |
| 26-02054-000   | Not Multiplexed Video  |
| <div style="display: flex; justify-content: space-between;"> <span>Refresh Features List</span> <span>Undo Last Changes</span> <span>Display Wiring Instructions</span> </div> |  |

04/10/2006

1040748

Fig. 1, Installed Features Example

Next, use one of the appropriate J1939 smart switch templates in ServiceLink (either from the BHM, SHM, or SEM) to identify which smart switches the vehicle recognizes.

**NOTE:** See the ServiceLink Users Guide under "Templates" for instructions on using Datalink Monitor Templates.

These templates have the unique smart switch ID number that indicates what smart switches the bulkhead module actually recognizes as being on the vehicle.

### Extra Smart Switch Fault

This fault indicates that a smart switch the vehicle is not programmed to use, is not found connected to one of the smart switch ports. This can be for any switch connected to the BHM, SHM, or SEM.

To troubleshoot this fault, first determine which smart switches the vehicle is programmed to use. Use the features screen in ServiceLink to determine which smart switches the vehicle should have. See the heading "Determining Which Smart Switches the Vehicle is Programmed to Use".

Next, identify which smart switches the vehicle recognizes using one of the appropriate J1939 smart switch templates in ServiceLink (BHM, SEM, or SHM Datalink Monitor Templates).

**NOTE:** See the ServiceLink Users Guide under "templates" for instructions on using Datalink Monitor Templates.

These templates will give you the unique smart switch ID number that indicates what smart switches the bulkhead module actually recognizes as being on the vehicle.

See **Specifications 400** to cross reference the smart switch ID number with the smart switch description. Compare this with the smart switches you were expecting based on what features the bulkhead module was programmed to use. See the heading "Determining Which Smart Switches the Vehicle is Programmed to Use". From this, determine which smart switch is extra or not being correctly identified.

### Duplicate Smart Switch Fault

This fault indicates that there are two or more identical smart switches connected to either BHM, SEM, or SHM/8SB smart switch ports.

To troubleshoot this fault, first determine which smart switches the vehicle is programmed to use. Use the features screen in ServiceLink to determine which smart switches the vehicle should have. See the heading "Determining Which Smart Switches the Vehicle is Programmed to Use".

The switch function that is duplicated will be two or more smart switch ports that have the same smart switch ID number shown in the applicable template. The duplicate switch must be disconnected.

**NOTE:** See the ServiceLink Users Guide under "templates" for instructions on using Datalink Monitor Templates.

### Smart Switches VBATT Short to Ground Fault

This fault indicates a smart switch indicator and/or backlight drive overloaded. Only smart switches connected to an SEM or SHM will report this fault.

Use ServiceLink to determine which smart switches are connected specifically to an SEM or SHM. Using ServiceLink, click on either the switch expansion module or the switch hub module icon on the left-hand list of ECUs. Then click on the smart switch tab. This will give you a list of all smart switches that are connected to the SEM and SHM. Smart switches connected to the bulkhead module will not show on this list. Troubleshoot these smart switches for short circuit conditions.

### Troubleshooting a Smart Switch Controlled Option that Does Not Work

Generally, when a function does not work when the smart switch is activated, the problem may be due to one of the following.

Input problems:

- Faulty smart switch.
- Faulty smart switch wiring.
- Other input conditions for the function to activate are not met. For example, the BHM does not sense that the ignition switch is in the ON position for the reading lights to activate.

Output problems:

- The output device is faulty.

## Troubleshooting

- The output device wiring is faulty.
- Output is not wired to the correct output pin.
- If the output is connected to the CHM (Chassis Module), there may be J1939 communication problems between the BHM and the CHM.
- If the output is connected to the EXM (Expansion Module), there may be J1939 communication problems between the BHM and the EXM.
- If the output is connected to the SHM, there may be communication problems between the BHM and SHM.

### Hardware problems:

- Faulty BHM, CHM, EXM, or SHM output drivers (internal BHM, CHM, EXM, or SHM problem).
- BHM, CHM, EXM, or SHM output driver circuit is overloaded (too much current will cause the output to shut off).

- Main VBATT fuse that supplies the output pin is blown.

### Software problems:

- Reference parameter is not compatible with vehicle options.
- Reference parameter has errors.

If a function does not work, and there are no active smart switch fault codes, then the following procedure will help to determine if the smart switch itself or its wiring is the cause of the problem. If smart switch fault codes are active, troubleshoot them first.

To determine if the smart switch or its wiring is the cause of the multiplexed function not working, follow the steps in **Table 2**.

| Smart Switch Problems |   |                      |   |
|-----------------------|---|----------------------|---|
| Step                  | Procedure   | Result               | Action  |
| 1                     | Are any smart switch faults active?   | Yes                  | Troubleshoot faults as outlined under previous headings.  |
|                       |   | No                   | Go to step 2.   |
| 2                     | Observe the smart switch indicator (if equipped) while attempting to operate the function with the switch.<br><br>NOTE: If the switch does not have an indicator light, go to step 3. | Blinks steady        | This means that function interlocks were met, but the BHM does not sense that the function actually engaged.<br><br>This does not indicate a problem with the smart switch.   |
|                       |   | On, then quickly off | This means that some other condition(s) is not met in order for the function to work. For example, if the function requires that the parking brake be set in order for the function to operate, and the parking brake is not set, then the function will not work because the condition is not met (parking brake not set). |
|                       |   | Off                  | Go to step 3.   |
| 3                     | Using ServiceLink, look at the BHM features screen.<br><br>Is there a reference parameter listed for the function, and does it indicate the use of a smart switch?                    | Yes                  | Go to step 4.   |
|                       |   | No                   | The reference parameter for the function is not loaded into the BHM. Load the correct reference parameter using ServiceLink.  |

| Smart Switch Problems |  |        |  |
|-----------------------|--|--------|--|
| Step                  | Procedure  | Result | Action   |
| 4                     | <p>In ServiceLink, open the applicable smart switch template (either for the BHM, SHM, or SEM). Locate the column that has the smart switch ID that matches software decimal value for that switch.</p> <p>While observing the input or position status on the template, operate the switch through each position. You should note a change in either the voltage input or position, depending on which template you are using.</p> <p>Do you see the change in switch position reflected in the template?</p> | Yes    | The problem is not with the smart switch or its wiring. The problem is either with the output function, or possibly a reference parameter problem. |
|                       |  | No     | Go to step 5.  |
| 5                     | <p>Remove the smart switch.</p> <p>Check resistance between pins 2 and 9 for each switch position. Compare readings with the values in <b>Specifications 400</b>.</p> <p>Are the resistance values within specifications?</p>  | Yes    | Check the wiring between pin 2 of the smart switch and either the BHM, SEM, or SHM/8SB. Repair as necessary.                                       |
|                       |  | No     | Replace the smart switch.  |

**Table 2, Smart Switch Problems**

| Smart Switch Pin-Out—Two Position Switch |                             |
|--|-----------------------------|
| Pin                                      | Circuit Description         |
| 2  | Switch Position Input       |
| 7  | Switch Function ID #1 Input |
| 8  | Switch Function ID #2 Input |
| 9  | Ground                      |
| 10                                       | Indicator (+)               |
| 11                                       | Backlighting (+)            |
| 12                                       | Indicator (-)               |

**Table 1, Smart Switch Pin-Out—Two Position Switch**

| Pilot Light Pin-Out |                            |
|---------------------|----------------------------|
| Pin                 | Circuit Description        |
| 2                   | Null Switch Position Input |
| 7                   | Pilot Light ID #1 Input    |
| 8                   | Pilot Light ID #2 Input    |
| 9                   | Ground                     |
| 10                  | Indicator (+)              |
| 12                  | Indicator (-)              |

**Table 3, Pilot Light Pin-Out**

| Smart Switch Pin-Out—Three Position Switch |                             |
|--|-----------------------------|
| Pin  | Circuit Description         |
| 2  | Switch position input       |
| 7  | Switch Function ID #1 Input |
| 8  | Switch Function ID #2 Input |
| 9  | Ground                      |
| 11   | Backlighting (+)            |

**Table 2, Smart Switch Pin-Out—Three Position Switch**

| Function ID Circuit Resistance |            |
|--------------------------------|------------|
| Pins                           | Resistance |
| Pins 7 to 9 (ID #1)            | R1 ± 1%    |
| Pins 8 to 9 (ID #2)            | R2 ± 1%    |

**Table 4, Function ID Circuit Resistance**

| Smart Switch Position Input Resistance (Pin 2 to Pin 9) |                     |                       |
|---|---------------------|-----------------------|
| Lower Switch Position                                   | Mid Switch Position | Upper Switch Position |
| 1138–1162 Ohms  | 9900–10 100 Ohms    | 3400–3468 Ohms        |

**Table 5, Smart Switch Position Input Resistance (Pin 2 to Pin 9)**

| Smart Switch/Pilot Light ID |                    |               |                 |
|-----------------------------|--------------------|---------------|-----------------|
| Smart Switch/Pilot Light    | Software ID Number | Type          | Switch Position |
|                             |                    |               | Upper           |
| Rear Dome Lights            | 273                | Rocker Switch | Middle          |
|                             |                    |               | Lower           |
|                             |                    |               | On              |
| Rear Dome Lights            | 273                | Rocker Switch | None            |
|                             |                    |               | Off             |
|                             |                    |               | Momentary On    |
| Rear Dome Lights            | 273                | Rocker Switch | On              |
|                             |                    |               | Off             |

# 54.16

## Smart Switches

### Specifications

| Smart Switch/Pilot Light ID |                    |               |                 |
|-----------------------------|--------------------|---------------|-----------------|
| Smart Switch/Pilot Light    | Software ID Number | Type          | Switch Position |
|                             |                    |               | Upper           |
|                             |                    |               | Middle          |
|                             |                    |               | Lower           |
| Front Dome Lights           | 274                | Rocker Switch | On              |
|                             |                    |               | None            |
|                             |                    |               | Off             |
| Dome Lights                 | 274                | Rocker Switch | On              |
|                             |                    |               | None            |
|                             |                    |               | Off             |
| Front Dome Lights Dimmer    | 274                | Rocker Switch | Momentary On    |
|                             |                    |               | On              |
|                             |                    |               | Off             |
| Dome Lights Dimmer          | 274                | Rocker Switch | Momentary On    |
|                             |                    |               | On              |
|                             |                    |               | Off             |
| Driver's Dome Light         | 275                | Rocker Switch | On              |
|                             |                    |               | None            |
|                             |                    |               | Off             |
| Driver's Dome Light Dimmer  | 275                | Rocker Switch | Momentary On    |
|                             |                    |               | On              |
|                             |                    |               | Off             |
| Warning Lights              | 276                | Rocker Switch | Momentary On    |
|                             |                    |               | On              |
|                             |                    |               | Off             |
| ID Lights                   | 277                | Rocker Switch | On              |
|                             |                    |               | None            |
|                             |                    |               | Off             |
| ID/Marker Lights            | 277                | Rocker Switch | On              |
|                             |                    |               | None            |
|                             |                    |               | Off             |
| Strobe Light                | 278                | Rocker Switch | On              |
|                             |                    |               | None            |
|                             |                    |               | Off             |
| Windshield Defroster Fan    | 279                | Rocker Switch | On              |
|                             |                    |               | On              |
|                             |                    |               | Off             |

| Smart Switch/Pilot Light ID              |                    |               |                 |
|--|--------------------|---------------|-----------------|
| Smart Switch/Pilot Light                 | Software ID Number | Type          | Switch Position |
|  |                    |               | Upper           |
|  |                    |               | Middle          |
|  |                    |               | Lower           |
| Luggage Compartment Light                | 280                | Rocker Switch | On              |
|  |                    |               | None            |
|  |                    |               | Off             |
| Air Horn                                 | 281                | Rocker Switch | Momentary On    |
|  |                    |               | None            |
|  |                    |               | Off             |
| Destination Sign                         | 282                | Rocker Switch | On              |
|  |                    |               | None            |
|  |                    |               | Off             |
| Air Service Door                         | 283                | Paddle Switch | On              |
|  |                    |               | None            |
|  |                    |               | Off             |
| Electric Service Door                    | 283                | Paddle Switch | Momentary On    |
|  |                    |               | Off             |
|  |                    |               | Momentary On    |
| Air Service Door (Three Position Switch) | 283                | Paddle Switch | On              |
|  |                    |               | On              |
|  |                    |               | Off             |
| Heater Pump                              | 284                | Rocker Switch | On              |
|  |                    |               | None            |
|  |                    |               | Off             |
| Mirror Heater                            | 289                | Rocker Switch | On              |
|  |                    |               | None            |
|  |                    |               | Off             |
| Left Front Heater                        | 290                | Rocker Switch | On              |
|  |                    |               | On              |
|  |                    |               | Off             |
| Left Rear Heater                         | 291                | Rocker Switch | On              |
|  |                    |               | On              |
|  |                    |               | Off             |
| Right Rear Heater                        | 292                | Rocker Switch | On              |
|  |                    |               | On              |
|  |                    |               | Off             |

# 54.16

## Smart Switches

### Specifications

| Smart Switch/Pilot Light ID      |                    |               |                 |
|----------------------------------|--------------------|---------------|-----------------|
| Smart Switch/Pilot Light         | Software ID Number | Type          | Switch Position |
|                                  |                    |               | Upper           |
|                                  |                    |               | Middle          |
|                                  |                    |               | Lower           |
| Crossing Arm Deactivation        | 293                | Rocker Switch | Momentary On    |
|                                  |                    |               | None            |
|                                  |                    |               | Off             |
| Noise Suppression                | 294                | Rocker Switch | Momentary On    |
|                                  |                    |               | None            |
|                                  |                    |               | Off             |
| Noise Suppression                | 294                | Rocker Switch | On              |
|                                  |                    |               | None            |
|                                  |                    |               | Off             |
| Speaker (Interior/Exterior)      | 295                | Rocker Switch | On              |
|                                  |                    |               | None            |
|                                  |                    |               | Off             |
| Amber Warning Lights             | 296                | Pilot Light   | —               |
| Red Warning Light                | 297                | Pilot Light   | —               |
| Brake Lights                     | 298                | Pilot Light   | —               |
| Rear Emergency Door              | 299                | Pilot Light   | —               |
| Warning Lights                   | 300                | Rocker Switch | On              |
|                                  |                    |               | Off             |
|                                  |                    |               | On              |
| Warning Lights                   | 305                | Rocker Switch | On              |
|                                  |                    |               | None            |
|                                  |                    |               | Off             |
| Warning Lights                   | 305                | Rocker Switch | Momentary On    |
|                                  |                    |               | None            |
|                                  |                    |               | Off             |
| Emergency Warning (Momentary On) | 306                | Rocker Switch | Momentary On    |
|                                  |                    |               | None            |
|                                  |                    |               | Off             |
| Emergency Warning (Off-On)       | 306                | Rocker Switch | On              |
|                                  |                    |               | None            |
|                                  |                    |               | Off             |

| Smart Switch/Pilot Light ID         |                    |               |                 |
|-------------------------------------|--------------------|---------------|-----------------|
| Smart Switch/Pilot Light            | Software ID Number | Type          | Switch Position |
|                                     |                    |               | Upper           |
|                                     |                    |               | Middle          |
|                                     |                    |               | Lower           |
| Warning Lights                      | 307                | Rocker Switch | Momentary On    |
|                                     |                    |               | None            |
|                                     |                    |               | Off             |
| Switch Backlight Dimmer             | 308                | Rocker Switch | Momentary On    |
|                                     |                    |               | On              |
|                                     |                    |               | Momentary On    |
| Vandalock Status                    | 309                | Pilot Light   | —               |
| Warning System (Master Pilot-Green) | 310                | Pilot Light   | —               |
| Warning System (Master Pilot-Red)   | 310                | Pilot Light   | —               |
| Red Warning Light                   | 310                | Pilot Light   | —               |
| Warning Lights                      | 311                | Rocker Switch | Momentary On    |
|                                     |                    |               | Off             |
|                                     |                    |               | Momentary On    |
| Wheelchair Lift                     | 312                | Rocker Switch | On              |
|                                     |                    |               | None            |
|                                     |                    |               | Off             |
| Video Camera                        | 313                | Rocker Switch | On              |
|                                     |                    |               | None            |
|                                     |                    |               | Off             |
| Hatch Vent Fan                      | 314                | Rocker Switch | On              |
|                                     |                    |               | None            |
|                                     |                    |               | Off             |
| Fog Lights                          | 315                | Rocker Switch | On              |
|                                     |                    |               | None            |
|                                     |                    |               | Off             |
| Emergency Door Light                | 316                | Rocker Switch | On              |
|                                     |                    |               | None            |
|                                     |                    |               | Off             |
| Warning Override                    | 321                | Rocker Switch | On              |
|                                     |                    |               | None            |
|                                     |                    |               | Off             |

# 54.16

## Smart Switches

### Specifications

| Smart Switch/Pilot Light ID     |                    |               |                 |
|---------------------------------|--------------------|---------------|-----------------|
| Smart Switch/Pilot Light        | Software ID Number | Type          | Switch Position |
|                                 |                    |               | Upper           |
|                                 |                    |               | Middle          |
|                                 |                    |               | Lower           |
| Warning Override Momentary      | 321                | Rocker Switch | Momentary On    |
|                                 |                    |               | None            |
|                                 |                    |               | Off             |
| Warning Override Momentary      | 321                | Rocker Switch | Momentary On    |
|                                 |                    |               | None            |
|                                 |                    |               | Momentary On    |
| A/C Fan                         | 322                | Rocker Switch | On              |
|                                 |                    |               | On              |
|                                 |                    |               | On              |
| Step/Door Light                 | 323                | Rocker Switch | On              |
|                                 |                    |               | None            |
|                                 |                    |               | Off             |
| Sander                          | 324                | Rocker Switch | On              |
|                                 |                    |               | None            |
|                                 |                    |               | Off             |
| Step Well Heater                | 325                | Rocker Switch | On              |
|                                 |                    |               | On              |
|                                 |                    |               | Off             |
| A/C                             | 326                | Rocker Switch | On              |
|                                 |                    |               | On              |
|                                 |                    |               | Off             |
| Engine Light                    | 327                | Rocker Switch | On              |
|                                 |                    |               | None            |
|                                 |                    |               | Off             |
| Left Side Defroster             | 328                | Rocker Switch | On              |
|                                 |                    |               | On              |
|                                 |                    |               | Off             |
| Reading Lights                  | 329                | Rocker Switch | On              |
|                                 |                    |               | None            |
|                                 |                    |               | Off             |
| Wheelchair Lift Power Red LED   | 330                | Pilot Light   | —               |
| Wheelchair Lift Power Green LED | 330                | Pilot Light   | —               |
| Post Trip Inspection            | 331                | Pilot Light   | —               |

| Smart Switch/Pilot Light ID  |                    |               |                 |
|------------------------------|--------------------|---------------|-----------------|
| Smart Switch/Pilot Light     | Software ID Number | Type          | Switch Position |
|                              |                    |               | Upper           |
|                              |                    |               | Middle          |
|                              |                    |               | Lower           |
| Heated Step Tread            | 332                | Rocker Switch | On              |
|                              |                    |               | None            |
|                              |                    |               | Off             |
| ADA Stop Request Pilot Light | 337                | Pilot Light   | —               |
| Stop Request Pilot Light     | 338                | Pilot Light   | —               |
| Stop Request Switch          | 339                | Rocker Switch | On              |
|                              |                    |               | None            |
|                              |                    |               | Off             |
| Side Emergency Door          | 340                | Pilot Light   | —               |
| Master Warning Switch        | 341                | Rocker Switch | On              |
|                              |                    |               | None            |
|                              |                    |               | Off             |
| Life Door                    | 342                | Pilot Light   | —               |

Table 6, Smart Switch/Pilot Light ID

### General Information

Attachment 26  
(TBB 54.11 Switch Hub Module Service.pdf)

The Switch Hub Module (SHM) is a required module of the vehicle electrical system, and acts as a slave to the Bulkhead Module (see **Section 54.01**). The SHM is used to connect up to 24 Smart Switches to the electrical system, and to control specific inputs and outputs.

The Switch Hub Module is mounted on a panel in the sealed compartment to the left of the driver that is accessible from inside the vehicle. It has nine harness connections, though all may not be used. See **Fig. 1**.

Smart Switches are connected to the Switch Hub Module (SHM) via intermediate modules called 8-Switch Banks (8SB). Up to 8 Smart Switches can be plugged directly into each bank, and up to three banks can be connected to the SHM, via J5-BANK A, J6-BANK B and J7-BANK C.

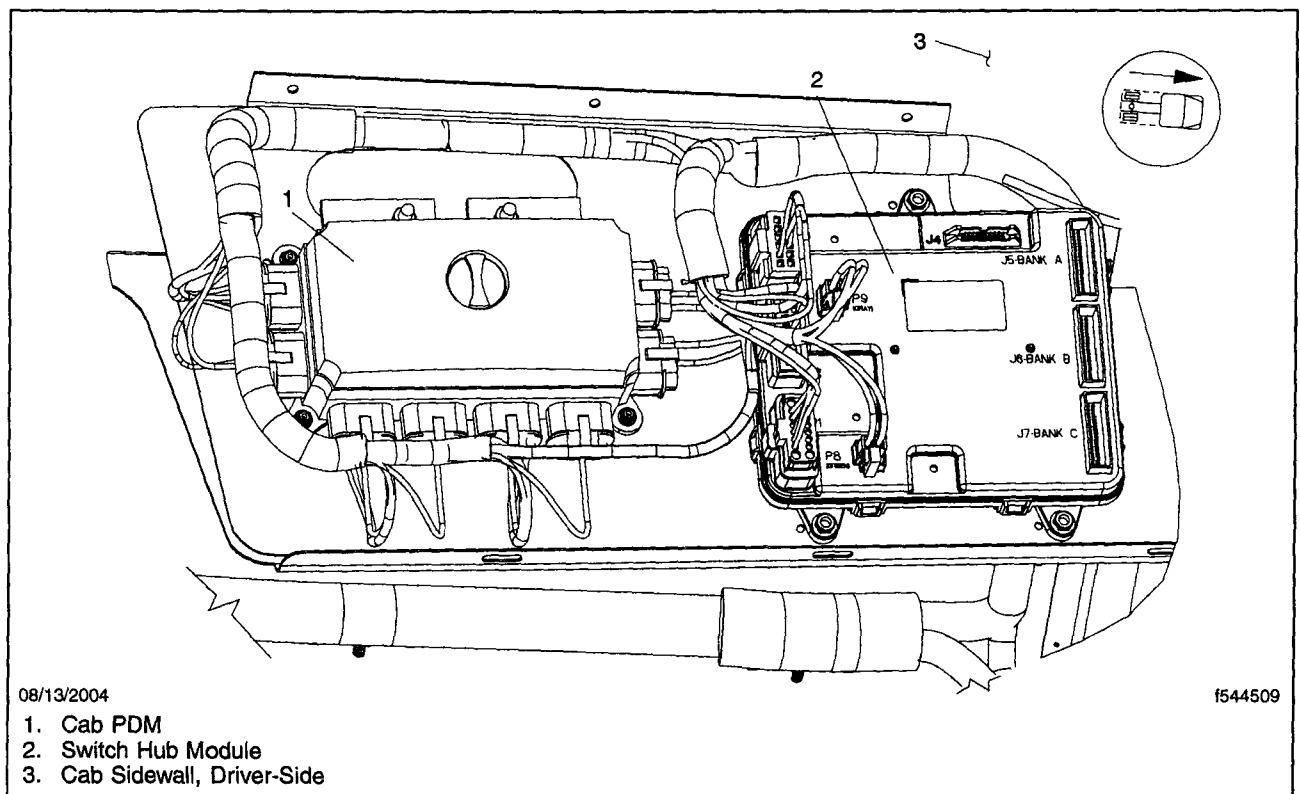

**Fig. 1, Driver-Side Cab Electronics**

## Switch Hub Module Replacement

### Replacement

**IMPORTANT:** It is normally not necessary to replace the Switch Hub Module (SHM). Removing and installing an electronic Switch Hub Module controller should be a last resort to solving electrical problems, unless a unit needs replacing due to physical damage. Follow troubleshooting procedures in Bulkhead Module (BHM) **Section 54.01, Troubleshooting 300** to help solve electrical problems involving this module before replacing the Bulkhead Module, Chassis Module, or Switch Hub Module. If troubleshooting indicates a malfunction of any of these modules, try reflashing the parameters on the BHM, or the software on the BHM and SHM before replacing either module. Also check external wiring.

See **Section 54.00, Electrical System**, for more information about the vehicle electrical system in general, and **Troubleshooting 300** in that section for help in troubleshooting the entire electrical system.

1. Disconnect the negative leads from the batteries.
2. Remove the fasteners that secure the switch panel on the driver's left side against the cab wall, then lift the switch panel away from the opening. See **Fig. 1**.

**NOTE:** The SHM is mounted on a panel in the compartment beneath the switch panel, next to the PDM. See **Fig. 2**.

3. Note the location of each of the harnesses before disconnecting them. Pay particular attention to the 8-Switch Bank (8SB) harness connectors to avoid inadvertently interchanging them on installation. Then unplug all connected electrical harnesses from the SHM. The module may not have harnesses plugged in to all connectors. For example, if a vehicle uses only one 8SB, there should not be any harnesses connected to J6 or J7. See **Fig. 3**.
4. Before removing the Switch Hub Module from its mounting plate, take note of its orientation; 8SB connectors A, B, and C should be toward the front of the vehicle.

Remove the mounting nuts that secure the SHM to the mounting plate and remove the SHM. See **Fig. 4**.

5. Properly orient the SHM on its mounting plate. See **Fig. 2**. Install the module on the mounting plate by securing the mounting nuts.

**NOTE:** The module may not have harnesses for all connectors.

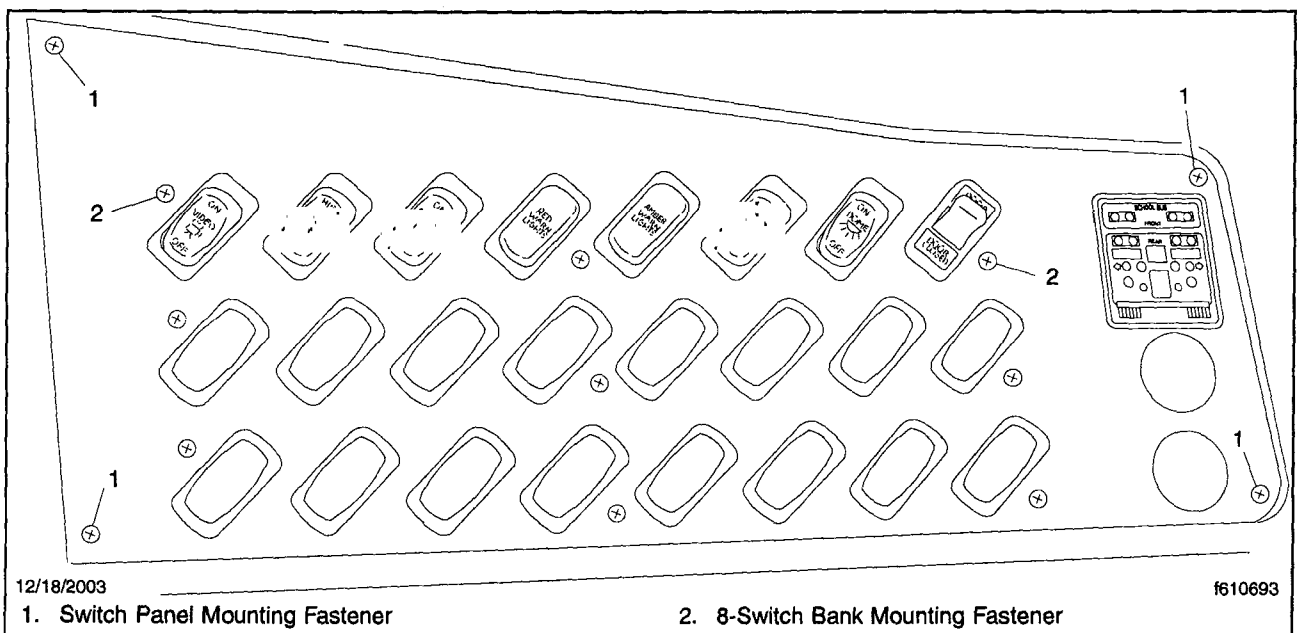

12/18/2003

1. Switch Panel Mounting Fastener

2. 8-Switch Bank Mounting Fastener

f610693

**Fig. 1, Switch Panel Mounting Fastener Locations**

# 54.11

# Switch Hub Module

## Switch Hub Module Replacement

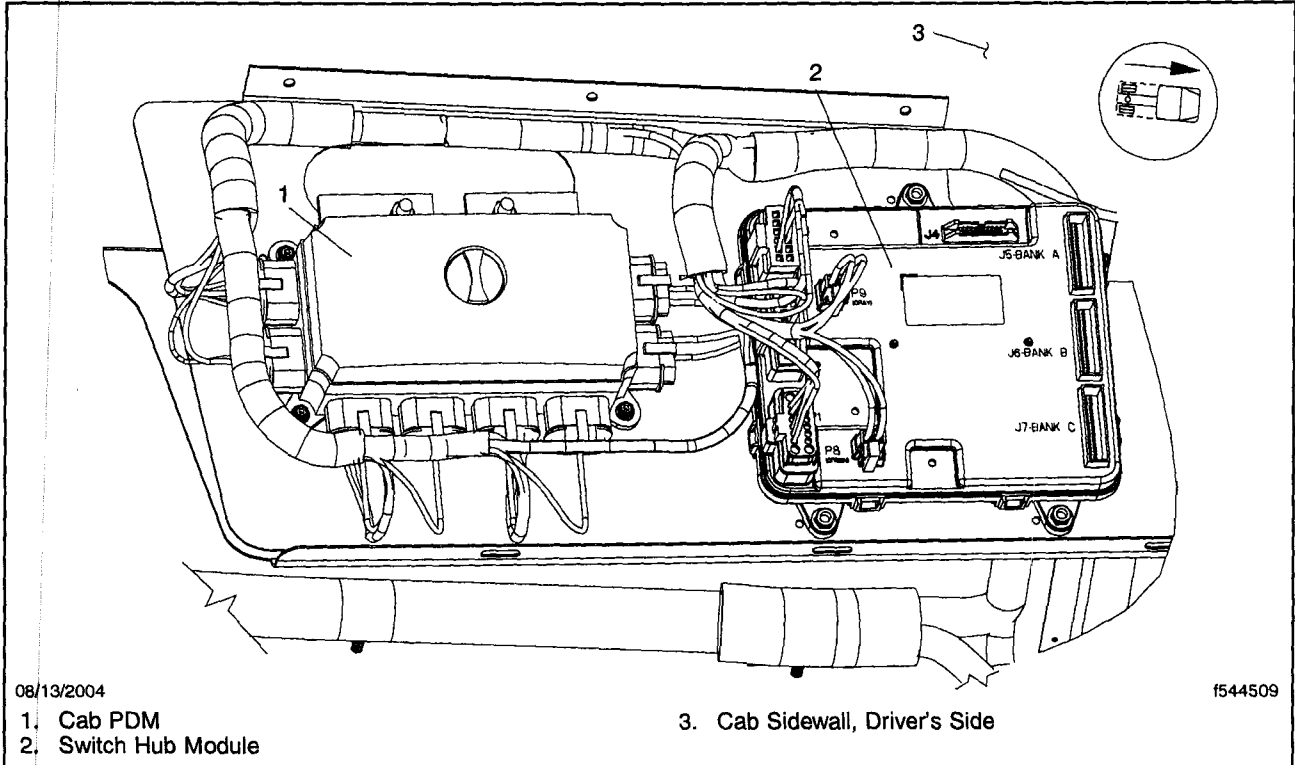

Fig. 2, Driver's Side Cab Electronics

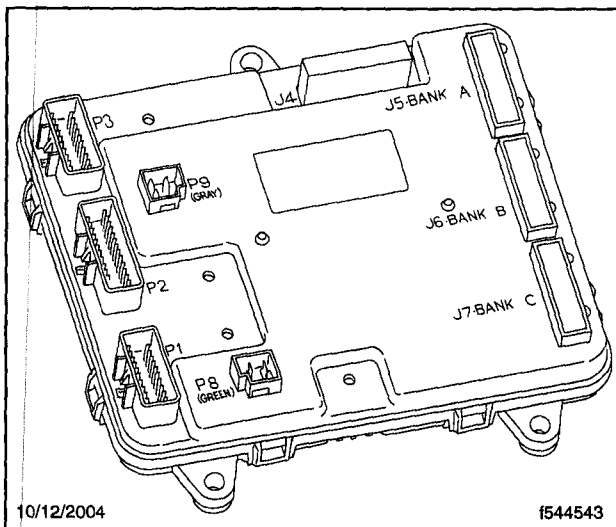
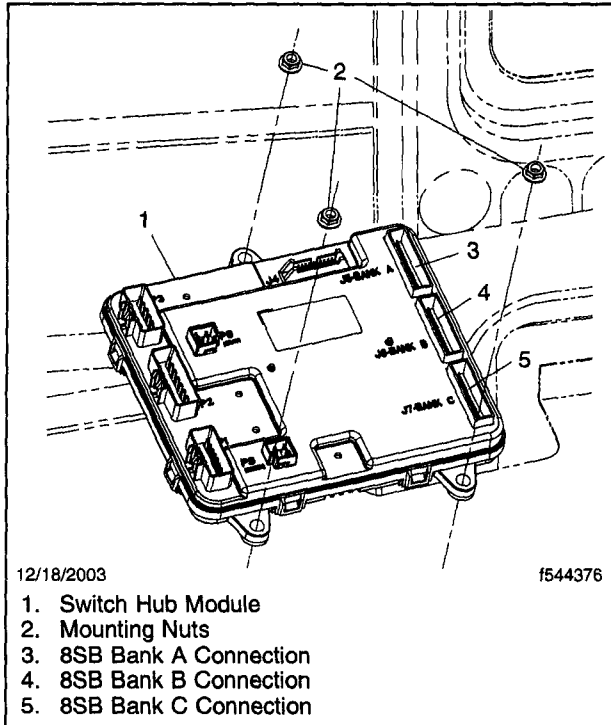

Fig. 3, Switch Hub Module

6. Plug all electrical wiring harnesses into the SHM connectors from which they were disconnected.
7. Place the switch panel over the compartment opening and attach the fasteners that secure the panel.
8. Connect the batteries.
9. Check to make sure electrical components work.



**Fig. 4, Switch Hub Module Installation**

## Eight-Switch Bank (8SB) Replacement

## General Information

The 8-Switch Bank (8SB) is an optional module of the vehicle electrical system. Its only purpose is to connect Smart Switches to the Switch Hub Module (SHM). The 8SB does not control any outputs.

There may be up to three 8SBs, for a total of up to 24 switches, connected to a SHM.

The 8SB is mounted directly under the switch panel located to the left of the driver. Smart Switches plug directly into the 8SB through the switch panel. Each 8SB has one harness connection, which connects it to the SHM.

The 8SB does not communicate on a data bus, therefore, it is not viewable as an Electrical Control Unit (ECU) icon from within ServiceLink. However, it is possible to use ServiceLink to see exactly which Smart Switches are connected to any 8SB. In ServiceLink, go to the "Smart Switches" tab located under either the SHM icon, or any Switch Expansion Module (SEM) icon. In the "Smart Switches" screen, a table lists which Smart Switches are connected to which 8SB (or to which SEM).

## Replacement

**IMPORTANT:** It is normally not necessary to replace the 8-Switch Bank. Removing and installing an electronic component should be a last resort to solving electrical problems, unless a unit needs replacing due to physical damage. Before replacing an 8SB or any of the electrical control modules, try reflashing the parameters on the Bulkhead Module (BHM), or the software on the BHM and the Switch Hub Module. Also check external wiring.

1. Disconnect the negative leads from the batteries.
2. Remove the fasteners that secure the switch panel on the driver's left side against the cab wall, then lift the switch panel away from the opening. See Fig. 1.
3. Unplug the electrical harness connector from the 8SB. See Fig. 2.

**NOTE:** Smart Switches will operate correctly regardless of their particular position on the 8SB. It is suggested that they be installed in the same positions from which they were removed, for the convenience of the vehicle operator.

4. Note the location of the Smart Switches plugged in to the 8SB to be removed, then remove all

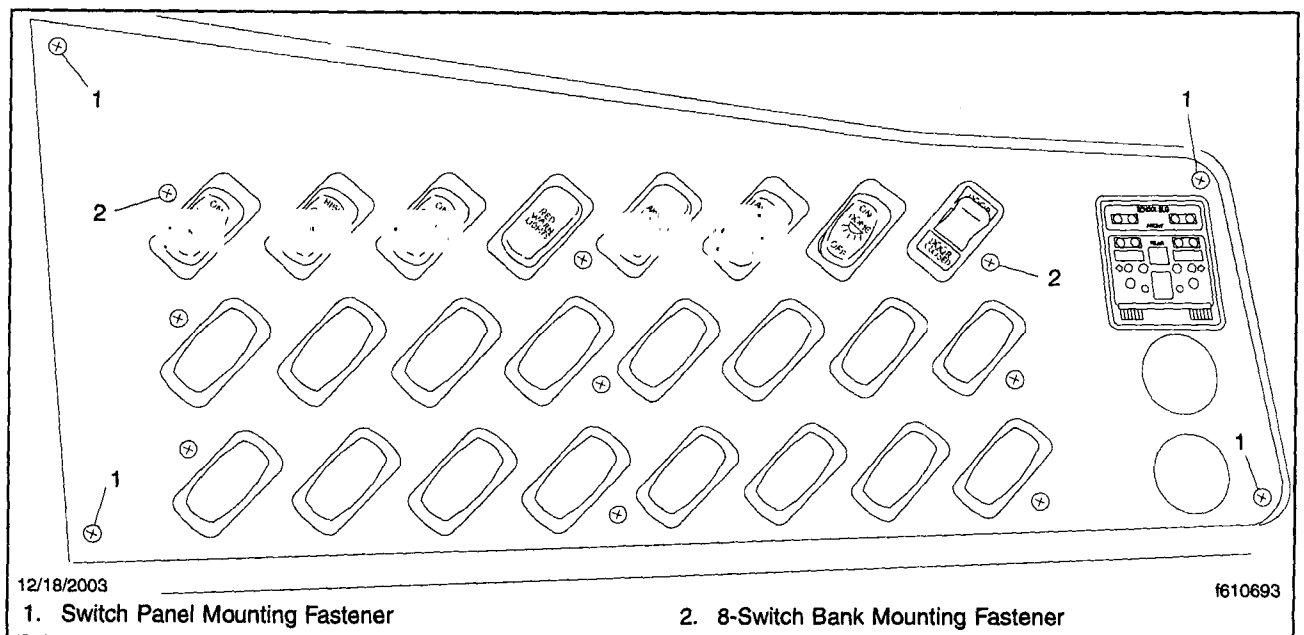

Fig. 1, Switch Panel Mounting Fastener Locations

## Eight-Switch Bank (8SB) Replacement

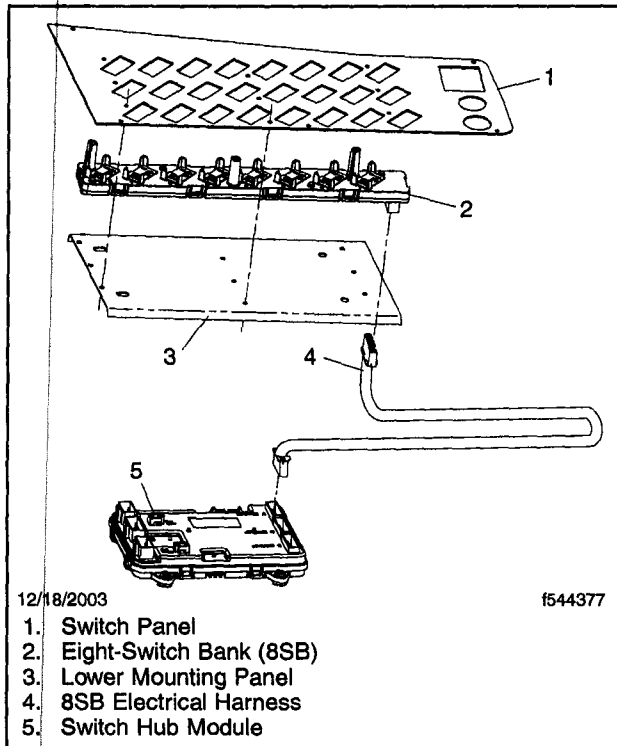

Fig. 2, Switch Panel Assembly Installation

connected switches (up to eight). To remove a switch, squeeze the locking tabs from the back of the switch, then pry out the switch from the front using a flat blade.

5. Note the orientation of the 8SB and remove the three mounting capscrews that secure the 8SB to the switch panel, then remove the 8SB.
  6. Properly orient the new 8SB and install the three mounting capscrews that secure the 8SB to the switch panel.
  7. Install all switches on the 8SB in the locations from which they were removed. To install a switch, push it through the switch panel opening until it is flush with the panel and the tabs lock.
  8. Connect the electrical harness connector to the 8SB.
  9. Place the switch panel in its opening and install the fasteners that secure the panel.
  10. Connect the batteries.
11. Check to make sure electrical components work.

## Switch Hub Module Communication

## Troubleshooting

When troubleshooting the Switch Hub Module (SHM), use ServiceLink as the diagnostic tool. First, determine if the SHM is communicating over both the J1708 and J1939 data buses. Follow the instructions below to determine if the SHM is communicating.

1. Connect a laptop computer to the diagnostic port on the data bus using an approved communication adapter.
2. Open ServiceLink in Online mode.
3. Turn the ignition switch to the ON position.
4. Click the "Connect" button in ServiceLink.
5. Verify that ServiceLink returns the correct vehicle serial number, then click "Continue".
6. Make certain the SHM is communicating with ServiceLink by checking to see that the SHM appears on the Electronic Control Unit (ECU) list in ServiceLink.

If the SHM is missing or not communicating, it will appear in red on the ServiceLink list. If the SHM is showing up in red, click the "Refresh" button in ServiceLink.

If the SHM appears as normal in the ServiceLink ECU list, the data bus communication is working correctly.

**NOTE:** See **Specifications 400** for information to locate power, ground, and both J1708/J1939 data bus pins.

7. If the SHM is not communicating (appears in red on the ServiceLink ECU list), thoroughly troubleshoot all power/ground/databus connections to the SHM. See the heading "Module Power Input Checks" for power and ground testing. Also try disconnecting and reconnecting the batteries to reset the SHM.

If all connections to the SHM are good, try to flash the SHM using ServiceLink. Follow the instructions below.

- 7.1 Click on the SHM icon on the left side of the screen.
- 7.2 Click on the flashing tab on the upper portion of the screen.
- 7.3 Verify that the software version is U.r.1.C1.01.00 or higher.
- 7.4 Click the "flash now" button in the dialog box.

If you already have the latest SHM software version, a message will appear saying "latest available version is already on SHM". Reflash SHM with the existing version. ServiceLink will then bring up a message saying "flashing SHM". Wait until ServiceLink is finished. The next screen message should read "successful flash." Click "OK".

If ServiceLink cannot flash the SHM due to the switch hub module being unresponsive, and all wiring checks do not show problems with connections, the SHM is damaged. Replace the switch hub module.

If you can flash the SHM, but suspect problems with inputs or outputs of the module, continue with these troubleshooting procedures.

**NOTE:** See **Section 54.01, Subject 300** when troubleshooting multiplexed features. While many of these multiplexed features use the SHM, they are programmed into the Bulkhead Module (BHM) and require communication between these two modules to function correctly.

## Module Power Input Checks

The main power feeds to the SHM go to connectors P8 (green connector) and P9 (gray connector). The module also requires a wake-up and ignition signal for the module to be enabled. See **Table 1**.

## Switch Hub Module Communication

| Wake-Up and Ignition Signal |  |                                 |   |
|-----------------------------|--|---------------------------------|---|
| Step                        | Procedure  | Result                          | Action  |
| 1                           | Back probe connector pin P8-1. Measure the voltage between P8-1 and a known good ground. | 12 volts (battery)              | Go to step 2.   |
|                             |  | 0 volts                         | Check fuse SHM_BATT_1 in the cab PDM. Troubleshoot circuit 14L_0 if the fuse is good. |
| 2                           | Back probe connector pin P8-2. Measure the voltage between P8-2 and a known good ground. | 12 volts (battery)              | Go to step 3.   |
|                             |  | 0 volts                         | Check fuse SHM_BATT_2 in the cab PDM. Troubleshoot circuit 14L_1 if the fuse is good. |
| 3                           | Back probe connector pin P9-1. Measure the voltage between P9-1 and a known good ground. | 12 volts (battery)              | Go to step 4.   |
|                             |  | 0 volts                         | Check fuse SHM_BATT_3 in the cab PDM. Troubleshoot circuit 14L_2 if the fuse is good. |
| 4                           | Back probe connector pin P9-2. Measure resistance between P9-2 and a known good ground.  | 0 ohms resistance               | Main power and ground feeds are good.   |
|                             |  | Measurable resistance is found. | Troubleshoot SHM ground circuit GND 1.  |

Table 1, Wake-Up and Ignition Signal

The primary wake-up input to the SHM (CKT 41F, pin P1-C) enables the SHM when this pin gets ground. The main wake-up signal comes from the BHM when the multiplexed system is turned on (as indicated by the ICU backlighting turning ON). There are other SHM wake-up pins, but P1-C is the main wake-up signal, and will always have ground when the multiplexed system is turned ON.

The ignition input to the SHM (CKT 52D, pin P1-B) enables the SHM when the key is in the ON or ACC position. This pin gets battery voltage.

## Troubleshooting SHM Outputs

Output pins on the SHM can be tested using Datalink Monitor (DLM) templates. Use these templates to monitor and/or control output pins, and J1939 data bus messaging. This will aid in isolating where the failure in the system exists, either inputs to the SHM, outputs from the SHM, or the SHM itself.

1. Connect a laptop computer to the vehicle using ServiceLink, if not already done.
2. Click on the Switch Hub Module icon on the left-hand ServiceLink screen.
3. Click on the templates tab in ServiceLink.

4. Click on the drop-down arrow under the J1939 templates. After you click on the drop-down arrow, you will see a list of available DLM templates for the SHM. The main output pins for the SHM are from connectors P1, P2, and P3.
5. Select the DLM template for the connector and pin you are attempting to test. For example, to test pin P1.H (right front amber warning light) select the DLM template titled "Switch Hub Module, connector P1."
6. Use the DLM template to monitor J1939 data bus communication between the SHM and BHM, and also monitor the status of the output pins (ON/OFF). DLM templates can also be used to manually turn output pins ON and OFF. See Fig. 1.
7. Isolate the output that you suspect is not working using the DLM template.
  - 7.1 Press "Enter Test Mode" on the DLM template.
  - 7.2 Press the ON button to the left of the output pin you are troubleshooting.
  - 7.3 Verify that both the "SHM to BHM" and "BHM to SHM" status on the DLM template are showing the output is ON.

## Switch Hub Module Communication

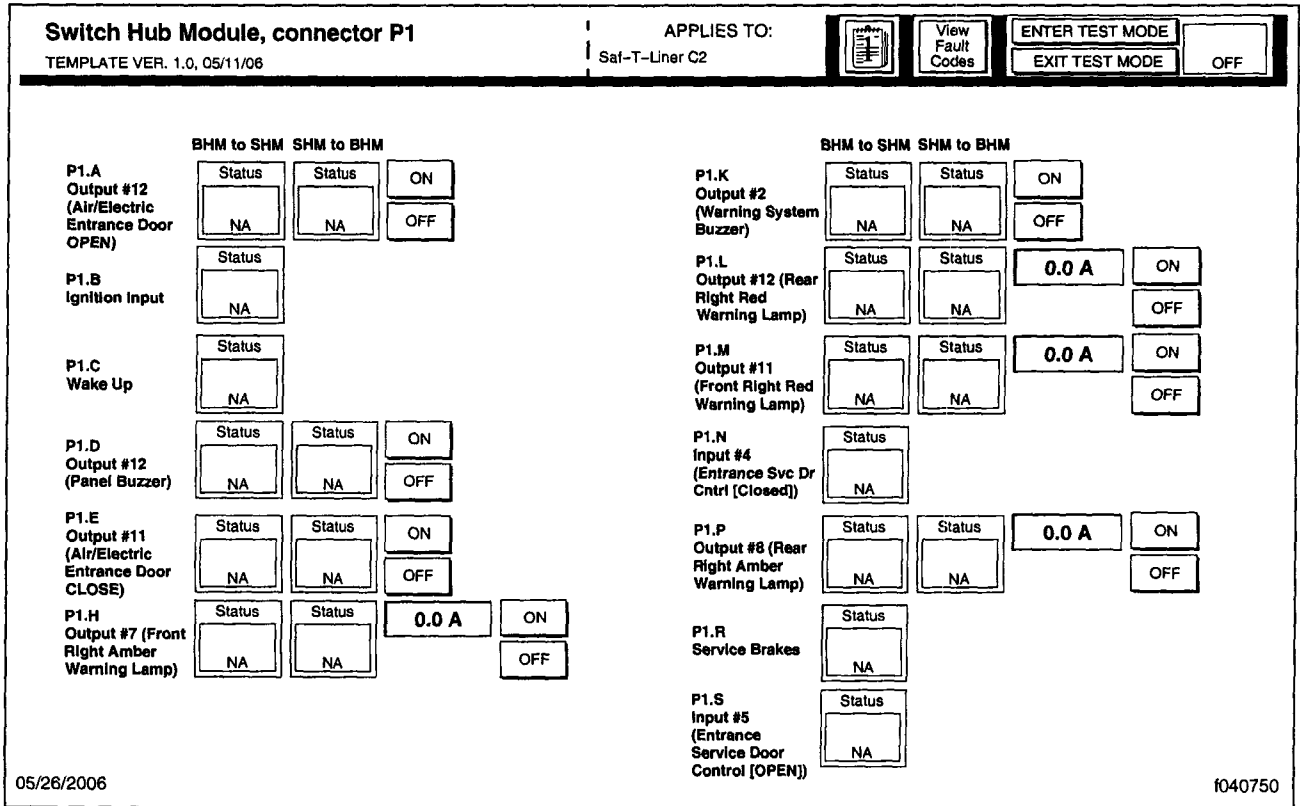

Fig. 1, Switch Hub Module, Connector P1

- 7.4 Verify that the function on the vehicle has turned ON (panel buzzer for example).
- 7.5 Press the OFF button to the left of the output pin you are troubleshooting.
- 7.6 Verify that both status indicators turn OFF.
- 7.7 Press the "Exit Test Mode" button at the top of the template.

If the status indicators turned ON and OFF during the above test, but the feature on the vehicle didn't turn ON, then OFF, the problem is not with the SHM itself. The problem is either within the output harness, or the device that output is controlling (a damaged panel buzzer for example).

If status indicators turned ON and OFF during the above test, and the device the output pin controls turns ON and OFF, then the SHM and output controls are

working correctly. There is a problem with the input control. See **Section 54.01, Subject 300** for BHM troubleshooting, or **Section 54.16, Subject 300** for Smart Switch troubleshooting.

If the "BHM to SHM" status indicator turned ON and OFF after the above test, but the "SHM to BHM" status indicator remained OFF, then there is likely an internal problem with the output pin drivers on the SHM. This indicates the SHM needs to be replaced.

If the "BHM to SHM" status indicator is not communicating, as indicated by a warning icon over the annunciator, then the problem is with the J1939 data bus communication from the BHM. See **Section 54.01, Subject 300** for BHM troubleshooting.

## Fault Code Information

### General Information

This subject contains information on all proprietary Switch Hub Module (SHM) fault codes for J1587 and J1939 data bus protocols. See **Table 1** and **Table 2**.

Also included is a reference table of all FMIs for both data bus protocols. See **Table 3**.

NOTE: In ServiceLink, J1587 fault codes are shown under J1708. J1587 and J1708 are essentially the same data bus protocol.

| J1587 SIDs for Switch Hub Module (SHM) MID 221 |                                    |              |
|--|------------------------------------|--------------|
| SID  | Description                        | Possible FMI |
| 221  | Smart Switch VBatt Short to Ground | 4            |
| 231  | No CAN Communication from BHM      | 9            |

**Table 1, J1587 SIDs for Switch Hub Module (SHM) MID 221**

| J1939 SPNs for Switch Hub Module (SHM) SA 49 |                                    |              |
|--|------------------------------------|--------------|
| SPN  | Description                        | Possible FMI |
| 2033   | No CAN communication from BHM      | 19           |
| 6914   | Smart Switch VBatt Short to Ground | 4            |

**Table 2, J1939 SPNs for Switch Hub Module (SHM) SA 49**

| Failure Mode Identifiers |   |   |
|--------------------------|---|---|
| FMI                      | J1939 Description   | J1587 Description   |
| 00                       | Data valid but above normal operational range — Most severe level | Data valid but above normal operational range (engine overheating)          |
| 01                       | Data valid but below normal operational range — Most severe level | Data valid but below normal operational range (engine oil pressure too low) |
| 31                       | Not available or condition exists                                 | —   |

**Table 3, Failure Mode Identifiers**

### Specifications

NOTE: Check ServiceLink for vehicle-specific pinout information.

For a plan view of the switch hub module pinouts, see Fig. 1.

For switch hub module pinout information, see Table 1, Table 2, Table 3, Table 4, Table 5, Table 6, Table 7, Table 8, and Table 9.

For switch hub module power supply fuses and associated outputs, see Table 10.

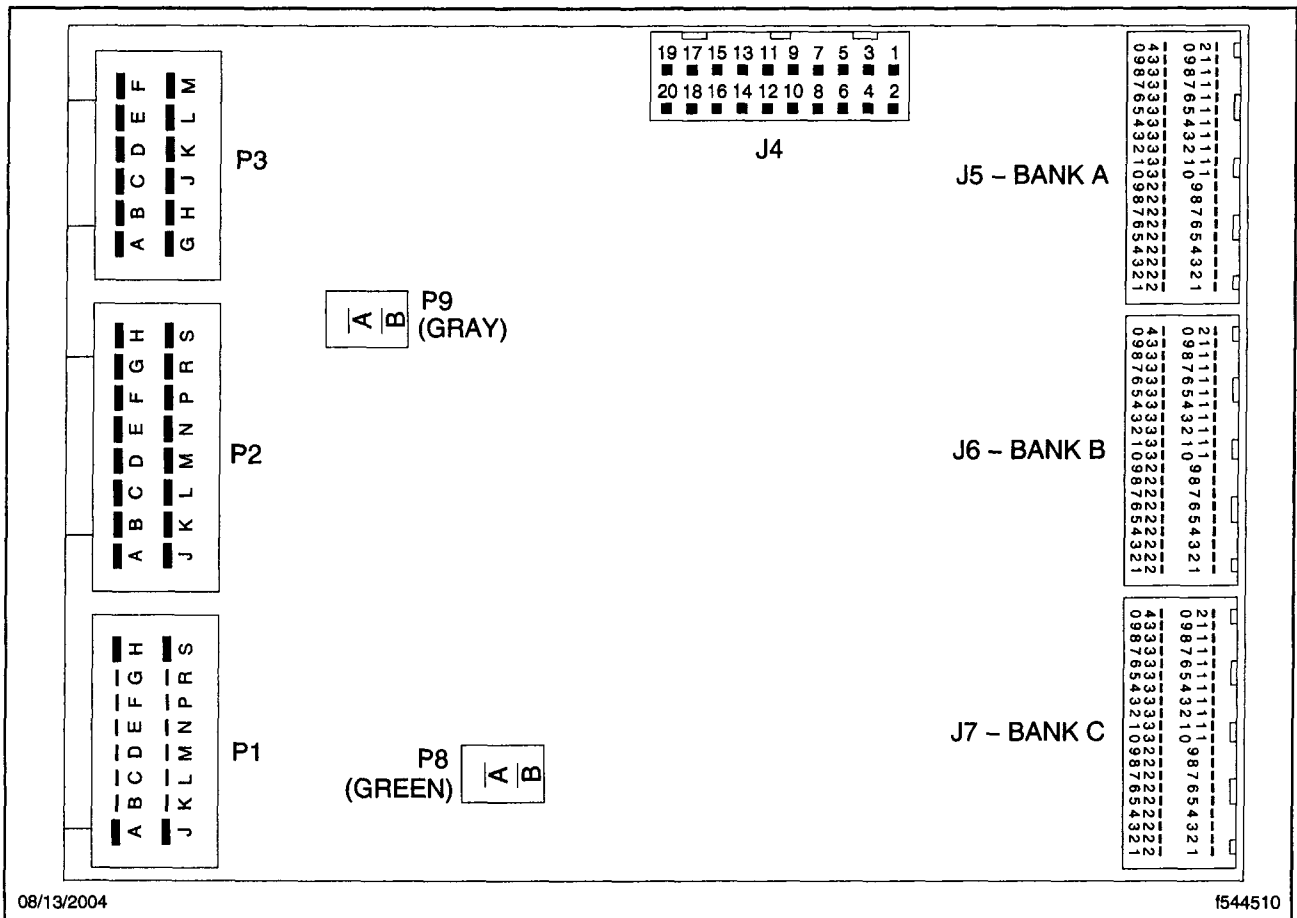

Fig. 1, Switch Hub Module Circuit Layout

| Pinouts at SHM Connector P1 |                        |                               |
|-----------------------------|------------------------|-------------------------------|
| Connector Pin               | Signal Name            | Signal Type                   |
| P1-A                        | Air/Electric Door Open | 0.5A HSD Output #12           |
| P1-B                        | Ignition               | Switch to Battery with Wakeup |
| P1-C                        | Module Wake-Up Signal  | Digital Input                 |
| P1-D                        | Buzzer 1—Switch Panel  | 0.5A HSD Output #1            |

## Specifications

| Pinouts at SHM Connector P1 |  |   |
|-----------------------------|--|---|
| Connector Pin               | Signal Name                            | Signal Type   |
| P1-E                        | Air/Electric Door Close                | 0.5A HSD Output #11   |
| P1-F                        | J1939- Data Bus Connection             | Data Bus Connection   |
| P1-G                        | J1939+ Data Bus Connection             | Data Bus Connection   |
| P1-H                        | Right Front Amber Warning              | 6.7A HSD Output #7 with Current Sense                       |
| P1-J                        | Unused                                 | —   |
| P1-K                        | Buzzer 2—Switch Panel (Warning System) | 0.5A HSD Output #2  |
| P1-L                        | Right Rear Red Warning                 | 6.7A HSD Output #12 with Current Sense                      |
| P1-M                        | Right Front Red Warning                | 6.7A HSD Output #11 with Current Sense                      |
| P1-N*                       | Entrance Service Door Closed           | Spare Digital Input #4                                      |
| P1-P                        | Right Rear Amber Warning               | 6.7A HSD Output #8 with Current Sense                       |
| P1-R                        | Service Brakes                         | Switch to GND with Wakeup and Hardware-based Output Control |
| P1-S*                       | Entrance Service Door Open             | Spare Digital Input #5                                      |

\* The function listed for this pin is the highest priority. If this function is not present, the output may be used for another function.

Table 1, Pinouts at SHM Connector P1

| Pinouts at SHM Connector P2 |  |   |
|-----------------------------|--|---|
| Connector Pin               | Signal Name                                  | Signal Type                                   |
| P2-A*                       | Heater 1—Driver-Side Front, Low-Speed Relay  | 0.5A HSD Output #6                            |
| P2-B*                       | Heater 1—Driver-Side Front, High-Speed Relay | 0.5A HSD Output #5                            |
| P2-C                        | Entrance Service Door Status                 | Spare Digital Input #1<br>Switch to GND Input |
| P2-D*                       | Strobe Light Relay                           | 0.5A HSD Output #8                            |
| P2-E                        | Lower Left Taillight                         | 3.0A HSD Output #1                            |
| P2-F                        | Lower Right Taillight                        | 3.0A HSD Output #2                            |
| P2-G                        | Escape Hatch Open                            | Spare Digital Input #3                        |
| P2-H                        | Unused                                       | —   |
| P2-J*                       | Air-Operated Stop Arm Control                | 0.5A HSD Output #10                           |
| P2-K                        | Left Rear Red Warning                        | 6.7A HSD Output #10 with Current Sense        |

| Pinouts at SHM Connector P2 |                         |   |
|-----------------------------|-------------------------|---|
| Connector Pin               | Signal Name             | Signal Type                                   |
| P2-L                        | Passenger Window Sash   | Spare Digital Input #2<br>Switch to GND Input |
| P2-M                        | Left Front Red Warning  | 6.7A HSD Output #9<br>with Current Sense      |
| P2-N*                       | Video Camera Box LED    | 0.5A HSD Output #7                            |
| P2-P                        | Left Rear Amber Warning | 6.7A HSD Output #6<br>with Current Sense      |
| P2-R                        | Lower Right Brake Light | 6.7A HSD Output #3<br>with Current Sense      |
| P2-S*                       | —                       | 0.5A HSD Output #9                            |

\* The function listed for this pin is the highest priority. If this function is not present, the output may be used for another function.

**Table 2, Pinouts at SHM Connector P2**

| Pinouts at SHM Connector P3 |  |  |
|-----------------------------|--|--|
| Connector Pin               | Signal Name                                    | Signal Type                                  |
| P3-A                        | Left Front Amber Warning                       | 6.7A HSD Output #5<br>with Current Sense     |
| P3-B                        | J1708- Data Bus Connection                     | Data Bus Connection                          |
| P3-C                        | Lower Right Backup Light                       | 6.7A PWM HSD Output<br>#1 with Current Sense |
| P3-D*                       | Heater 2—Driver-Side Rear,<br>Low-Speed Relay  | 0.5A HSD Output #3                           |
| P3-E                        | Lower Left Backup Light                        | 6.7A HSD Output #2<br>with Current Sense     |
| P3-F                        | Upper Left Taillight                           | 3.0A HSD Output #4<br>with Hardware Control  |
| P3-G                        | Front Dome Light                               | 13A PWM LSD Output<br>#1                     |
| P3-H                        | Lower Left Brake Light                         | 6.7A HSD Output #4<br>with Current Sense     |
| P3-J                        | J1708+ Data Bus Connection                     | Data Bus Connection                          |
| P3-K                        | Upper Right Taillight                          | 3.0A HSD Output #3<br>with Hardware Control  |
| P3-L*                       | Heater 2—Driver-Side Rear,<br>High-Speed Relay | 0.5A HSD Output #4                           |
| P3-M                        | Rear Dome Light                                | 13A PWM LSD Output<br>#2                     |

\* The function listed for this pin is the highest priority. If this function is not present, the output may be used for another function.

**Table 3, Pinouts at SHM Connector P3**

# 54.11

## Switch Hub Module

### Specifications

| Pinouts at SHM Connector J4 |                                 |                            |
|-----------------------------|---------------------------------|----------------------------|
| Connector Pin               | Signal Name                     | Signal Type                |
| J4-1                        | Right Backup                    | BOD Low-side LED #1 Drive  |
| J4-2                        | Left Backup                     | BOD Low-side LED #2 Drive  |
| J4-3                        | Right Tail                      | BOD Low-side LED #3 Drive  |
| J4-4                        | Left Tail                       | BOD Low-side LED #4 Drive  |
| J4-5                        | Right Turn                      | BOD Low-side LED #5 Drive  |
| J4-6                        | Left Turn                       | BOD Low-side LED #6 Drive  |
| J4-7                        | Right Stop                      | BOD Low-side LED #7 Drive  |
| J4-8                        | Left Stop                       | BOD Low-side LED #8 Drive  |
| J4-9                        | Battery Power                   | SS and BOD Power           |
| J4-10                       | Battery Power                   | SS and BOD Power           |
| J4-11                       | No Connect (Battery on Display) | —                          |
| J4-12                       | No Connect (Battery on Display) | —                          |
| J4-13                       | Right Rear Red                  | BOD Low-side LED #9 Drive  |
| J4-14                       | Left Rear Red                   | BOD Low-side LED #10 Drive |
| J4-15                       | Right Rear Amber                | BOD Low-side LED #11 Drive |
| J4-16                       | Left Rear Amber                 | BOD Low-side LED #12 Drive |
| J4-17                       | Right Front Red                 | BOD Low-side LED #13 Drive |
| J4-18                       | Left Front Red                  | BOD Low-side LED #14 Drive |
| J4-19                       | Right Front Amber               | BOD Low-side LED #15 Drive |
| J4-20                       | Left Front Amber                | BOD Low-side LED #16 Drive |

Table 4, Pinouts at SHM Connector J4

| Pinouts at SHM Connector J5—Bank A |                        |                           |
|------------------------------------|------------------------|---------------------------|
| Connector Pin                      | Signal Name            | Signal Type               |
| J5-1                               | Smart Switch Ground    | Signal Ground             |
| J5-2                               | SSA6 Indicator         | Smart Switch LED Drive    |
| J5-3                               | SSA4 Indicator         | Smart Switch LED Drive    |
| J5-4                               | SSA3 Indicator         | Smart Switch LED Drive    |
| J5-5                               | SSA1 Indicator         | Smart Switch LED Drive    |
| J5-6                               | Smart Switch Backlight | Smart Switch Backlight    |
| J5-7                               | SSA2 Switch Position   | Smart Switch Analog Input |
| J5-8                               | Smart Switch Ground    | Signal Ground             |
| J5-9                               | SSA4 Switch Position   | Smart Switch Analog Input |
| J5-10                              | SSA3 ID1               | Smart Switch Analog Input |
| J5-11                              | SSA2 ID1               | Smart Switch Analog Input |

| Pinouts at SHM Connector J5—Bank A |                      |                           |
|------------------------------------|----------------------|---------------------------|
| Connector Pin                      | Signal Name          | Signal Type               |
| J5-12                              | SSA1 ID2             | Smart Switch Analog Input |
| J5-13                              | SSA4 ID1             | Smart Switch Analog Input |
| J5-14                              | SSA5 ID2             | Smart Switch Analog Input |
| J5-15                              | Smart Switch Ground  | Signal Ground             |
| J5-16                              | SSA6 Switch Position | Smart Switch Analog Input |
| J5-17                              | SSA6 ID1             | Smart Switch Analog Input |
| J5-18                              | SSA7 ID1             | Smart Switch Analog Input |
| J5-19                              | SSA8 ID2             | Smart Switch Analog Input |
| J5-20                              | Smart Switch Ground  | Signal Ground             |
| J5-21                              | SSA8 Indicator       | Smart Switch LED Drive    |
| J5-22                              | SSA7 Indicator       | Smart Switch LED Drive    |
| J5-23                              | SSA5 Indicator       | Smart Switch LED Drive    |
| J5-24                              | Smart Switch Ground  | Signal Ground             |
| J5-25                              | SSA2 Indicator       | Smart Switch LED Drive    |
| J5-26                              | Smart Switch Power   | SS and BOD Power          |
| J5-27                              | SSA1 Switch Position | Smart Switch Analog Input |
| J5-28                              | SSA3 Switch Position | Smart Switch Analog Input |
| J5-29                              | SSA4 ID2             | Smart Switch Analog Input |
| J5-30                              | SSA3 ID2             | Smart Switch Analog Input |
| J5-31                              | SSA2 ID2             | Smart Switch Analog Input |
| J5-32                              | Smart Switch Ground  | Signal Ground             |
| J5-33                              | SSA1 ID1             | Smart Switch Analog Input |
| J5-34                              | SSA5 Switch Position | Smart Switch Analog Input |
| J5-35                              | SSA5 ID1             | Smart Switch Analog Input |
| J5-36                              | SSA6 ID2             | Smart Switch Analog Input |
| J5-37                              | SSA7 Switch Position | Smart Switch Analog Input |
| J5-38                              | SSA7 ID2             | Smart Switch Analog Input |
| J5-39                              | SSA8 Switch Position | Smart Switch Analog Input |
| J5-40                              | SSA8 ID1             | Smart Switch Analog Input |

Table 5, Pinouts at SHM Connector J5—Bank A

| Pinouts at SHM Connector J6—Bank B |                     |                        |
|------------------------------------|---------------------|------------------------|
| Connector Pin                      | Signal Name         | Signal Type            |
| J6-1                               | Smart Switch Ground | Signal Ground          |
| J6-2                               | SSB6 Indicator      | Smart Switch LED Drive |
| J6-3                               | SSB4 Indicator      | Smart Switch LED Drive |

# 54.11

## Switch Hub Module

### Specifications

| Pinouts at SHM Connector J6—Bank B |                        |                           |
|------------------------------------|------------------------|---------------------------|
| Connector Pin                      | Signal Name            | Signal Type               |
| J6-4                               | SSB3 Indicator         | Smart Switch LED Drive    |
| J6-5                               | SSB1 Indicator         | Smart Switch LED Drive    |
| J6-6                               | Smart Switch Backlight | Smart Switch Backlight    |
| J6-7                               | SSB2 Switch Position   | Smart Switch Analog Input |
| J6-8                               | Smart Switch Ground    | Signal Ground             |
| J6-9                               | SSB4 Switch Position   | Smart Switch Analog Input |
| J6-10                              | SSB3 ID1               | Smart Switch Analog Input |
| J6-11                              | SSB2 ID1               | Smart Switch Analog Input |
| J6-12                              | SSB1 ID2               | Smart Switch Analog Input |
| J6-13                              | SSB4 ID1               | Smart Switch Analog Input |
| J6-14                              | SSB5 ID2               | Smart Switch Analog Input |
| J6-15                              | Smart Switch Ground    | Signal Ground             |
| J6-16                              | SSB6 Switch Position   | Smart Switch Analog Input |
| J6-17                              | SSB6 ID1               | Smart Switch Analog Input |
| J6-18                              | SSB7 ID1               | Smart Switch Analog Input |
| J6-19                              | SSB8 ID2               | Smart Switch Analog Input |
| J6-20                              | Smart Switch Ground    | Signal Ground             |
| J6-21                              | SSB8 Indicator         | Smart Switch LED Drive    |
| J6-22                              | SSB7 Indicator         | Smart Switch LED Drive    |
| J6-23                              | SSB5 Indicator         | Smart Switch LED Drive    |
| J6-24                              | Smart Switch Ground    | Signal Ground             |
| J6-25                              | SSB2 Indicator         | Smart Switch LED Drive    |
| J6-26                              | Smart Switch Power     | SS and BOD Power          |
| J6-27                              | SSB1 Switch Position   | Smart Switch Analog Input |
| J6-28                              | SSB3 Switch Position   | Smart Switch Analog Input |
| J6-29                              | SSB4 ID2               | Smart Switch Analog Input |
| J6-30                              | SSB3 ID2               | Smart Switch Analog Input |
| J6-31                              | SSB2 ID2               | Smart Switch Analog Input |
| J6-32                              | Smart Switch Ground    | Signal Ground             |
| J6-33                              | SSB1 ID1               | Smart Switch Analog Input |
| J6-34                              | SSB5 Switch Position   | Smart Switch Analog Input |
| J6-35                              | SSB5 ID1               | Smart Switch Analog Input |
| J6-36                              | SSB6 ID2               | Smart Switch Analog Input |
| J6-37                              | SSB7 Switch Position   | Smart Switch Analog Input |
| J6-38                              | SSB7 ID2               | Smart Switch Analog Input |

| Pinouts at SHM Connector J6—Bank B |                      |                           |
|------------------------------------|----------------------|---------------------------|
| Connector Pin                      | Signal Name          | Signal Type               |
| J6-39                              | SSB8 Switch Position | Smart Switch Analog Input |
| J6-40                              | SSB8 ID1             | Smart Switch Analog Input |

Table 6, Pinouts at SHM Connector J6—Bank B

| Pinouts at SHM Connector J7—Bank C |                        |                           |
|------------------------------------|------------------------|---------------------------|
| Connector Pin                      | Signal Name            | Signal Type               |
| J7-1                               | Smart Switch Ground    | Signal Ground             |
| J7-2                               | SSC6 Indicator         | Smart Switch LED Drive    |
| J7-3                               | SSC4 Indicator         | Smart Switch LED Drive    |
| J7-4                               | SSC3 Indicator         | Smart Switch LED Drive    |
| J7-5                               | SSC1 Indicator         | Smart Switch LED Drive    |
| J7-6                               | Smart Switch Backlight | Smart Switch Backlight    |
| J7-7                               | SSC2 Switch Position   | Smart Switch Analog Input |
| J7-8                               | Smart Switch Ground    | Signal Ground             |
| J7-9                               | SSC4 Switch Position   | Smart Switch Analog Input |
| J7-10                              | SSC3 ID1               | Smart Switch Analog Input |
| J7-11                              | SSC2 ID1               | Smart Switch Analog Input |
| J7-12                              | SSC1 ID2               | Smart Switch Analog Input |
| J7-13                              | SSC4 ID1               | Smart Switch Analog Input |
| J7-14                              | SSC5 ID2               | Smart Switch Analog Input |
| J7-15                              | Smart Switch Ground    | Signal Ground             |
| J7-16                              | SSC6 Switch Position   | Smart Switch Analog Input |
| J7-17                              | SSC6 ID1               | Smart Switch Analog Input |
| J7-18                              | SSC7 ID1               | Smart Switch Analog Input |
| J7-19                              | SSC8 ID2               | Smart Switch Analog Input |
| J7-20                              | Smart Switch Ground    | Signal Ground             |
| J7-21                              | SSC8 Indicator         | Smart Switch LED Drive    |
| J7-22                              | SSC7 Indicator         | Smart Switch LED Drive    |
| J7-23                              | SSC5 Indicator         | Smart Switch LED Drive    |
| J7-24                              | Smart Switch Ground    | Signal Ground             |
| J7-25                              | SSC2 Indicator         | Smart Switch LED Drive    |
| J7-26                              | Smart Switch Power     | SS and BOD Power          |
| J7-27                              | SSC1 Switch Position   | Smart Switch Analog Input |
| J7-28                              | SSC3 Switch Position   | Smart Switch Analog Input |
| J7-29                              | SSC4 ID2               | Smart Switch Analog Input |
| J7-30                              | SSC3 ID2               | Smart Switch Analog Input |

## Specifications

| Pinouts at SHM Connector J7—Bank C |                      |                           |
|------------------------------------|----------------------|---------------------------|
| Connector Pin                      | Signal Name          | Signal Type               |
| J7-31                              | SSC2 ID2             | Smart Switch Analog Input |
| J7-32                              | Smart Switch Ground  | Signal Ground             |
| J7-33                              | SSC1 ID1             | Smart Switch Analog Input |
| J7-34                              | SSC5 Switch Position | Smart Switch Analog Input |
| J7-35                              | SSC5 ID1             | Smart Switch Analog Input |
| J7-36                              | SSC6 ID2             | Smart Switch Analog Input |
| J7-37                              | SSC7 Switch Position | Smart Switch Analog Input |
| J7-38                              | SSC7 ID2             | Smart Switch Analog Input |
| J7-39                              | SSC8 Switch Position | Smart Switch Analog Input |
| J7-40                              | SSC8 ID1             | Smart Switch Analog Input |

Table 7, Pinouts at SHM Connector J7—Bank C

| Pinouts at SHM Connector P8 |                           |              |
|-----------------------------|---------------------------|--------------|
| Connector Pin               | Signal Name               | Signal Type  |
| P8-1                        | Main Battery Power Feed 1 | Module Power |
| P8-2                        | Main Battery Power Feed 2 | Module Power |

Table 8, Pinouts at SHM Connector P8

| Pinouts at SHM Connector P9 |                           |               |
|-----------------------------|---------------------------|---------------|
| Connector Pin               | Signal Name               | Signal Type   |
| P9-1                        | Main Battery Power Feed 3 | Module Power  |
| P9-2                        | Main Ground Feed          | Module Ground |

Table 9, Pinouts at SHM Connector P9

| Switch Hub Module Power Supply Fuses and Associated Outputs |                     |                                |   |                |
|---|---------------------|--------------------------------|---|----------------|
| SHM Power Input   | SHM Power Input Pin | Fuse Supplying SHM Power Input | SHM Outputs Supplied                                | SHM Output Pin |
| Power In  |                     |                                | Power Out   |                |
| VBAT1   | P8.A                | Fuse: SHM_BATT_1 (30A)         | 0.5A HSD Output #12 (air/electric door open)        | P1.A           |
|   |                     |                                | 0.5A HSD Output #1 (Panel Buzzer)                   | P1.D           |
|   |                     |                                | 0.5A HSD Output #11 (Air/Electric Door Close)       | P1.E           |
|   |                     |                                | 0.5A HSD Output #2 (Warning System Buzzer)          | P1.K           |
|   |                     |                                | 6.7A HSD Output #10 (LH Rear Red Warning)           | P2.K           |
|   |                     |                                | 6.7A HSD Output #9 (LH Front Red Warning)           | P2.M           |
|   |                     |                                | 6.7A HSD Output #6 (LH Rear Amber Warning)          | P2.P           |
|   |                     |                                | 6.7A HSD Output #5 (LH Front Amber Warning)         | P3.A           |
|   |                     |                                | 6.7A HSD Output #1 (RH Lower Reverse Light)         | P3.C           |
| VBAT2   | P8.B                | Fuse: SHM_BATT_2 (30A)         | 6.7A HSD Output #7 (RH Front Amber Warning)         | P1.H           |
|   |                     |                                | 6.7A HSD Output #12 (RH Rear Red Warning)           | P1.L           |
|   |                     |                                | 6.7A HSD Output #11 (RH Front Red Warning)          | P1.M           |
|   |                     |                                | 6.7A HSD Output #8 (RH Rear Amber Warning)          | P1.P           |
|   |                     |                                | 0.5A HSD Output #10 (Differential Lock)             | P2.J           |
|   |                     |                                | 0.5A HSD Output #9 (Park Brake Set)                 | P2.S           |
|   |                     |                                | 0.5A HSD Output #3 (Htr #2 LH AFT Low-Speed Relay)  | P3.D           |
|   |                     |                                | 6.7A HSD Output #2 (LH Lower Reverse Light)         | P3.E           |
|   |                     |                                | 0.5A HSD Output #4 (Htr #2 LH AFT High-Speed Relay) | P3.L           |
| VBAT3   | P9.8                | Fuse: SHM_BATT_3 (30A)         | 0.5A HSD Output #6 (Htr #1 LH FWD Low-Speed Relay)  | P2.A           |
|   |                     |                                | 0.5A HSD Output #5 (Htr #2 LH FWD High-Speed Relay) | P2.B           |
|   |                     |                                | 0.5A HSD Output #8 (Strobe Light Relay)             | P2.D           |
|   |                     |                                | 3.0A HSD Output #1 (LH Lower Taillight)             | P2.E           |
|   |                     |                                | 3.0A HSD Output (RH Lower Taillight)                | P2.F           |
|   |                     |                                | 0.5A HSD Output #7 (Video Camera Box LED)           | P2.N           |
|   |                     |                                | 6.7A HSD Output #3 (RH Lower Brake Light)           | P2.R           |
|   |                     |                                | 3.0A HSD Output #4 (LH Upper Taillight)             | P3.F           |
|   |                     |                                | 6.7A HSD Output #4 (LH Lower Brake Light)           | P3.H           |
| 3.0A HSD Output #3 (RH Upper Taillight)                     | P3.K                |                                |   |                |

Table 10, Switch Hub Module Power Supply Fuses and Associated Outputs

### General Information

The Switch Expansion Module (SEM) is an optional module of the vehicle electrical system, and acts as a slave to the Bulkhead Module (BHM). An SEM is used on a vehicle to add smart switches when all smart switch locations on the vehicle are already in use, or when installing a smart switch in a location that existing smart switch harnesses or modules cannot access, such as overhead. The SEM does not control any outputs.

Since it is optional, there may be from zero to four SEMs on a vehicle. There can be up to six smart switches connected to each SEM. It has two harness connections, though both may not be used.

The SEM comes in two versions, dash-mounted (see **Fig. 1**) and remote-mounted (see **Fig. 2**). When dash-mounted, the smart switches may plug directly into the unit. When mounted remotely the smart switches must be plugged in through a harness connected to connector J2.

Both versions are supported by a single version of software.

The SEM communicates over only the SAE J1939 data bus; it has no J1708/J1587 communication.

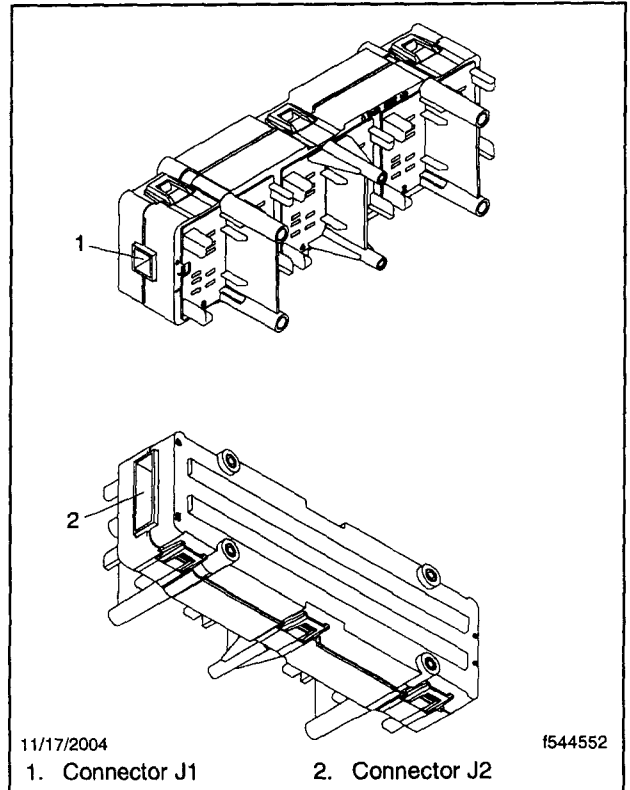

**Fig. 1, Dash-Mounted SEM**

Attachment 27  
(TBB 54.12 Switch Expansion Module  
Service.pdf )

# 54.12

## Switch Expansion Module

### General Information

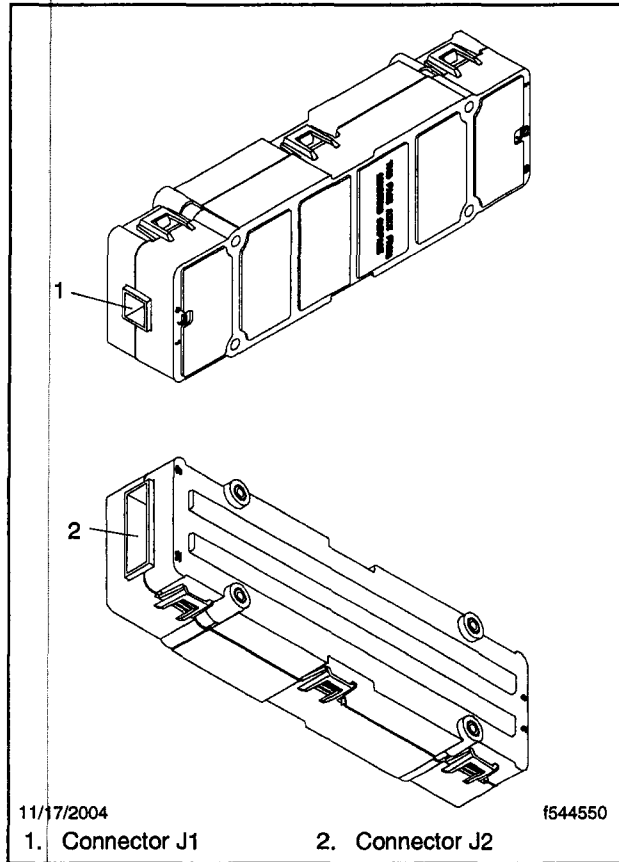

**Fig. 2, Remote-Mounted SEM**

## SEM J1939 Source Address Claiming Scheme

Switch Expansion Modules (SEMs) on the J1939 data bus claim a J1939 "source address." The source address identifies the module and can be viewed using ServiceLink. See **Table 1** for a list of the possible SEM source addresses.

| SEM J1939 Source Address Claiming Scheme |            |
|--|------------|
| Source Address                           | SEM Number |
| 128                                      | SEM #1     |
| 129                                      | SEM #2     |
| 130                                      | SEM #3     |
| 131                                      | SEM #4     |

**Table 1, SEM J1939 Source Address Claiming Scheme**

Switch Expansion Modules on a vehicle are numbered SEM #1 through SEM #4 depending on the serial number of the SEM. The SEM with the lowest serial number (printed on a decal on the SEM casing) attempts to claim the lowest SEM source address, 128. Each additional SEM then claims a source address in similar fashion from low to high: the SEM with the next-highest serial number claims the next-highest source address (129), and so on until all SEMs have claimed a source address.

Once an SEM is installed and claims an address, it will store that as a preferred source address. Every time the vehicle is turned on after that, the SEM will attempt to re-use that preferred source address. This way, each SEM should appear in ServiceLink as the same SEM number (SEM #1 through SEM #4) each time ServiceLink is connected, regardless of whether an SEM is removed, or whether the physical locations of the SEMs on the vehicle have changed. The only exception is when an SEM with a lower serial number is added.

If a new SEM is installed that has a serial number lower than those already on the vehicle, the new SEM will claim the lowest source address (128) and bump up the source addresses of the other SEMs. The SEM that used to claim the source address of 128 must now claim 129, the SEM that used to claim 129 must now claim 130, and so on.

## Invalid SEM (Unresponsive)

An SEM that has problems during flashing may no longer be able to claim an address in the proper way. Instead it will report on the J1939 data bus with a Source Address of 133, and appear in ServiceLink as an icon labeled "Invalid SEM (Unresponsive)." It will not report any make, model, or software ID. In this case, the technician can still access the Flashing tab and attempt to flash the SEM to recover it.

## Locating the Correct SEM to Troubleshoot

To assist the technician in determining the specific SEM a given Smart Switch is connected to, ServiceLink has a "Smart Switches" tab, located under the SEM icon. There, the technician will find an "Identify SEM" button that can be used to briefly flash the indicator lights of a bank of Smart Switches connected to a specific SEM. This allows the technician to locate the correct SEM for troubleshooting Smart Switches.

## Adding an SEM

After installing an SEM, turn the vehicle ignition to the ON position and connect to the vehicle using ServiceLink. Notice that the newly installed SEM appears in ServiceLink as a new SEM icon in the left side bar.

The following may be encountered in ServiceLink:

- If the new SEM's serial number is lower than those already on the vehicle, it claims Source Address 128 and appears as SEM #1.
- If the new SEM's serial number is higher than those already on the vehicle, it appears as the next SEM in numerical order. For example, if there are two SEMs already on the vehicle, appearing in ServiceLink as SEM #1 and SEM #2, the new SEM appears in ServiceLink as SEM #3.
- If the new SEM's serial number is between the serial numbers of SEMs already on the vehicle, the new SEM bumps up the 2nd SEM. The new SEM appears as SEM #2, and the SEM that used to be SEM #2 appears as SEM #3. Since SEM #1 still has the lowest serial number, it still appears as SEM #1.

---

## ServiceLink Interaction

- If there are already four SEMs installed on the vehicle, the installation of a fifth SEM causes an icon to appear in ServiceLink labeled "Invalid ECU (duplicate) – Unable to claim address," since four is the maximum number of SEMs allowed on a vehicle. The fifth SEM should show a source address of 254.

To identify an SEM, go into the SEM's icon in ServiceLink. Click on the "Smart Switches" tab, and use the "Identify SEM" button to flash the indicator lights of the Smart Switches connected to that particular SEM. This makes it possible to locate the SEM, and to see which Smart Switches are connected to which SEM.

---

## Removing an SEM

1. Connect to the vehicle in ServiceLink and take note of the icons that appear for the SEMs connected to the vehicle.
2. Remove the SEM.
3. Reconnect to the vehicle in ServiceLink and take note of the icons that appear for the SEMs connected to the vehicle.
4. The icon for the removed SEM should be gone, and none of the other SEMs still on the vehicle should change their order. For example, if there are three SEMs on a vehicle, appearing in ServiceLink as SEM #1, SEM #2, and SEM #3, and the 2nd SEM is removed, on reconnecting to the vehicle in ServiceLink the icons for SEM #1 and SEM #3 still appear, and the icon for SEM #2 is gone.

---

## Replacing an SEM

1. After removing the old SEM, the expected behavior should be as described under the previous heading "Removing an SEM." However, if the SEM being removed was not appearing in ServiceLink, then no change should occur.
2. After installing the new SEM, the expected behavior should be as outlined in the previous section "Adding an SEM."
3. When in doubt, use ServiceLink to identify a particular SEM. See the heading titled "Adding an SEM."

### Fault Codes

This subject contains information on all proprietary Switch Expansion Module (SEM) fault codes for J1939 data bus protocols. See **Table 1**.

Also included is a reference table of Failure Mode Identifiers (FMIs) for J1939 data bus protocols. See **Table 2**.

| J1939 SPNs for Switch Expansion Module (SEM) SAs 128 through 131 |                                    |              |
|--|------------------------------------|--------------|
| SPN  | SAE J1939 Description              | Possible FMI |
| 2033   | No CAN communication from BHM      | 19           |
| 6914   | Smart Switch VBatt Short to Ground | 04           |

**Table 1, J1939 SPNs for Switch Expansion Module (SEM) SAs 128 through 131**

| Failure Mode Identifiers |                                     |
|--------------------------|-------------------------------------|
| FMI                      | SAE J1939 Description               |
| 19                       | Received network data in error      |
| 04                       | Voltage below normal or shorted low |

**Table 2, Failure Mode Identifiers**

### Specifications

For an isometric view of the dash-mounted Switch Expansion Module (SEM), see **Fig. 1**. For an end view of the dash-mounted module connectors, see **Fig. 2**.

For an isometric view of the remote-mounted SEM, see **Fig. 3**. For an end view of the remote-mounted module connectors, see **Fig. 4**.

For SEM pinout definitions at connector J1, see **Table 1**.

For SEM pinout definitions at connector J2, see **Table 2**.

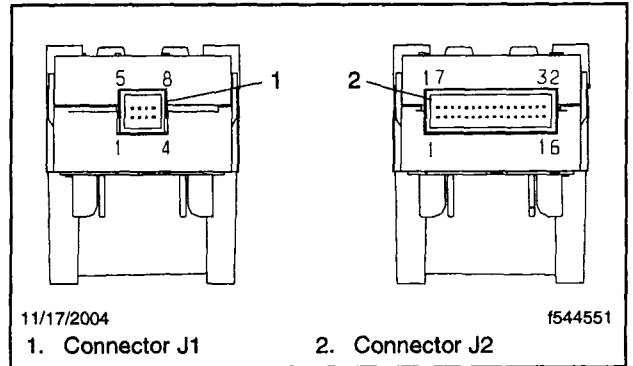

**Fig. 2, Dash-Mounted SEM (end views, both ends)**

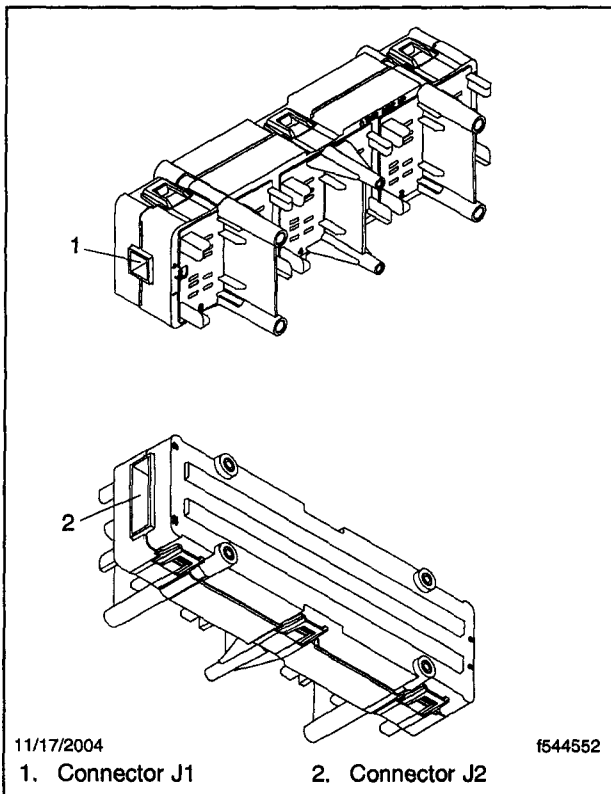

**Fig. 1, Dash-Mounted SEM**

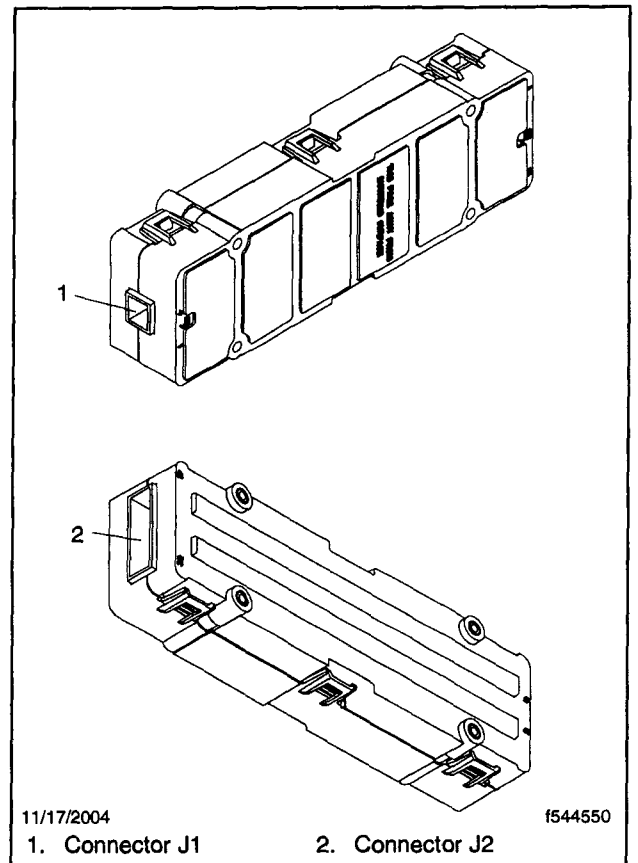
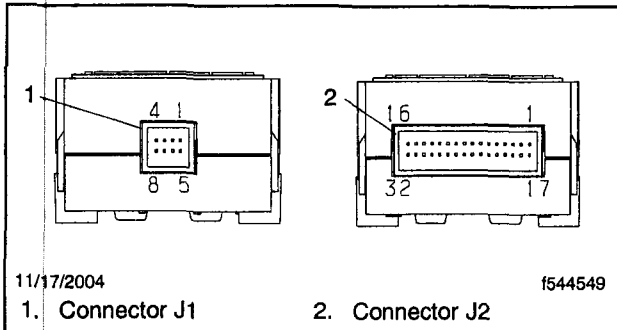

**Fig. 3, Remote-Mounted SEM**

# 54.12

## Switch Expansion Module

### Specifications



**Fig. 4, Remote-Mounted SEM (end views, both ends)**

| SEM Pinout Definitions at Connector J1 |                          |                |               |
|--|--------------------------|----------------|---------------|
| Connector Pin                          | Signal Name              | Type           | Current: Amps |
| J1-1                                   | VBAT1 (unswitched power) | Power          | 1             |
| J1-2                                   | System Wakeup            | Bi-Directional | —             |
| J1-3                                   | System Ignition          | Input          | —             |
| J1-4                                   | J1939- Data Bus          | Comm           | —             |
| J1-5                                   | GND                      | Ground         | —             |
| J1-6                                   | GND                      | Ground         | —             |
| J1-7                                   | GND                      | Ground         | —             |
| J1-8                                   | J1939+ Data Bus          | Comm           | —             |

**Table 1, SEM Pinout Definitions at Connector J1**

| SEM Pinout Definitions at Connector J2 |                        |                           |               |
|--|------------------------|---------------------------|---------------|
| Connector Pin                          | Signal Name            | Type                      | Current: Amps |
| J2-1                                   | Smart Switch Ground    | Signal Ground             | —             |
| J2-2                                   | SS5 Indicator          | Smart Switch LED Drive    | —             |
| J2-3                                   | SS3 Indicator          | Smart Switch LED Drive    | —             |
| J2-4                                   | SS1 Indicator          | Smart Switch LED Drive    | —             |
| J2-5                                   | SS6 ID1                | Smart Switch Analog Input | —             |
| J2-6                                   | SS5 ID2                | Smart Switch Analog Input | —             |
| J2-7                                   | SS5 Switch Position    | Smart Switch Analog Input | —             |
| J2-8                                   | Smart Switch Backlight | Smart Switch Backlight    | 0.2           |
| J2-9                                   | Smart Switch Vbat      | Smart Switch Vbat         | 0.2           |
| J2-10                                  | SS4 ID2                | Smart Switch Analog Input | —             |
| J2-11                                  | SS4 Switch Position    | Smart Switch Analog Input | —             |
| J2-12                                  | SS3 ID1                | Smart Switch Analog Input | —             |
| J2-13                                  | SS2 ID2                | Smart Switch Analog Input | —             |

| SEM Pinout Definitions at Connector J2 |                     |                           |               |
|--|---------------------|---------------------------|---------------|
| Connector Pin                          | Signal Name         | Type                      | Current: Amps |
| J2-14                                  | SS2 Switch Position | Smart Switch Analog Input | —             |
| J2-15                                  | SS1 ID1             | Smart Switch Analog Input | —             |
| J2-16                                  | Smart Switch Ground | Signal Ground             | —             |
| J2-17                                  | Smart Switch Ground | Signal Ground             | —             |
| J2-18                                  | SS6 Indicator       | Smart Switch LED Drive    | —             |
| J2-19                                  | SS4 Indicator       | Smart Switch LED Drive    | —             |
| J2-20                                  | SS2 Indicator       | Smart Switch LED Drive    | —             |
| J2-21                                  | SS6 ID2             | Smart Switch Analog Input | —             |
| J2-22                                  | SS6 Switch Position | Smart Switch Analog Input | —             |
| J2-23                                  | SS5 ID1             | Smart Switch Analog Input | —             |
| J2-24                                  | Smart Switch Ground | Signal Ground             | —             |
| J2-25                                  | Smart Switch Ground | Signal Ground             | —             |
| J2-26                                  | SS4 ID 1            | Smart Switch Analog Input | —             |
| J2-27                                  | SS3 ID2             | Smart Switch Analog Input | —             |
| J2-28                                  | SS3 Switch Position | Smart Switch Analog Input | —             |
| J2-29                                  | SS2 ID1             | Smart Switch Analog Input | —             |
| J2-30                                  | SS1 ID2             | Smart Switch Analog Input | —             |
| J2-31                                  | SS1 Switch Position | Smart Switch Analog Input | —             |
| J2-32                                  | Smart Switch Ground | Signal Ground             | —             |

Table 2, SEM Pinout Definitions at Connector J2