



6460 KATELLA AVENUE
CYPRESS, CALIFORNIA 90630-5208
(714) 372-6000

MAILING ADDRESS:
P.O. BOX 6400
CYPRESS, CALIFORNIA 90630-0064

July 28, 2006

Mr. Jeffrey L. Quandt, Chief
Vehicle Control Division
NHTSA Office of Defects Investigation

RE: NVS-213-aan, RQ-06-007

Dear Mr. Quandt:

Mitsubishi respectfully submits the requested information in response to Recall Query RQ-06-007. As discussed earlier with your office, Mitsubishi has limited the vehicles included in this RQ response to the 2001 and 2002 Mitsubishi Montero. The 2000 MY used a vacuum brake booster system with no accumulator and the 2003 MY used an "Active Skid Control" system which utilized a non-diaphragm type accumulator.

Based on our phone call and email of July 20, 2006 and approved by your office, this response includes questions 1 through 7, 11, and 12. The remaining responses to questions 8 through 10, 13 and 14 will be provided on or before August 24, 2006.

Databases for responses to questions 1, 2, 3, and 5 are attached in separate Access files, and are also provided by mail on a CD. Other attachments included with this submission are listed below. Should you have any questions or need additional information, you can reach me at one of the contact points listed below.

Sincerely,

Kent Reeves, National Manager
Product Support & Technical Compliance
Phone: 714-372-6362
Fax: 714-934-4242
Email: kreeves@mmsa.com

Attachment For Question No.	Description
4	Customer Complaints
4	Field Reports
6	Nature Code Chart
6	Cause Code Chart
7	SR-01-008
7	SR-01-008REV
7	SR-01-008REVII
7	ATIN-01-SR-010
12	Accumulator Parts Demand

Q.1. State, by model and year, the number of subject vehicles Mitsubishi has manufactured for sale or lease in the United States. Separately, for each subject vehicle manufactured to date by Mitsubishi, state the following:

- a. Vehicle identification number (VIN)
- b. Make
- c. Model
- d. Model Year
- e. Date of manufacture
- f. Date warranty coverage commenced
- g. State in the United States where the vehicle was originally sold or leased (or delivered for sale or lease)
- h. Whether the vehicle was subject to recall 01V-254
- i. Whether the subject recall repairs were performed
- j. Date the subject recall repairs were performed

A.1. The Microsoft Access file named "PRODUCTION DATA.mdb" provided in this mailing contains the above information in the format requested.

Q.2. State the number of each of the following, received by Mitsubishi, or of which Mitsubishi is otherwise aware, which relate to, or may relate to the alleged defect in the subject vehicles:

- a. Consumer complaints, including those from fleet operators
- b. Field reports, including dealer field reports
- c. Reports involving a crash, injury, or fatality, based on claims against the manufacturer involving a death or injury, notices received by the manufacturer alleging or proving that a death or injury was caused by a possible defect in a subject vehicle, property damage claims, consumer complaints, or field reports
- d. Property damage claims
- e. Third-party arbitration proceedings where Mitsubishi is or was a party to the arbitration
- f. Lawsuits, both pending and closed, in which Mitsubishi is or was a defendant or co-defendant.

For subparts "a" through "d." state the total number of each item (e.g., consumer complaints, field reports, etc.) separately. Multiple incidents involving the same vehicle are to be counted separately. Multiple reports of the same incident are also to be counted separately (i.e., a consumer complaint and a field report involving the same incident in which a crash occurred are to be counted as a crash report, a field report and a consumer complaint).

In addition, for items "c" through "d," provide a summary description of the alleged problem and causal and contributing factors and Mitsubishi's assessment of the problem, with a summary of the significant underlying facts and evidence. For items "e" and "f," identify the parties to the action, as well as the caption, court, docket number, and data on which the complaint or other document initiating the action was filed.

A.2. The Microsoft Access file named "REQUEST NUMBER TWO DATA.mdb" provided in this mailing contains the above information.

Type	Total number
Item a. Customer complaints	22*
Item b. Field reports	10
Item c. Crashes involving injury	1**
Item d. Property damage claims	0

* Three customer complaints are also ODI cases No. 100111753, No. 10155605, & No. 10092744.

** This case was included in the ODI report under case No. 10092744.

For Items "c" and "d":

VIN	Summary	Causal/ Contributing Factors	Assessment	Significant Facts/ Evidence Summary
JA4MW31R82J [REDACTED]	Customer states that brake pedal went to the floor upon trying to stop.	Unknown	Claim is unrelated to accumulator diaphragm damage.	Accumulator diaphragm damage is evidenced by noise when the brake pedal is pressed. Customer did not mention any such noise.

For items "e" and "f":

- ◆ There are no third-party arbitration proceedings related to the alleged defect in the subject vehicles.
- ◆ There are no lawsuits related to the alleged defect in the subject vehicles.

Q.3. Separately, for each item (complaint, report, claim, notice, or matter) within the scope of the items in Request No. 2, state the following information:

- a. Mitsubishi's file number or other identifier used
- b. Category of each item, as identified in Request No. 2 (i.e., consumer complaint, field report, etc.)
- c. Vehicle owner or fleet name (and fleet contact person), address, and telephone number
- d. Vehicle VIN
- e. Vehicle make, model and model year
- f. Vehicle's mileage at time of incident
- g. Incident date
- h. Report or claim date
- i. Whether a crash is alleged
- j. Whether property damage is alleged
- k. Number of alleged injuries, if any
- l. Number of alleged fatalities, if any

A.3. **The Microsoft Access file named "REQUEST NUMBER TWO DATA.mdb" provided in this mailing contains the above information in the format requested.**

Q.4. Produce copies of all documents related to each item within the scope of Request No. 2. Organize the documents separately by category (i.e., consumer complaints, field reports, etc.) and describe the method Mitsubishi used for organizing the documents.

A.4. **Copies of these documents are provided in this mailing. The documents are organized by category, then date of report.**

Q.5. State, by model and year, the total count for all of the following categories of claims, collectively, that have been paid by Mitsubishi to date that relate to, or may relate to, the alleged defect in the subject vehicles: warranty claims; extended warranty claims; claims for goodwill services that were provided; field, zone, or similar adjustments and reimbursements; and warranty claims or repairs made in accordance with a procedure specified in a technical service bulletin or customer satisfaction campaign

Separately, for each claim, state the following information:

- a. Mitsubishi's claim number
- b. Vehicle owner or fleet name (and fleet contact person) and telephone number

- c. VIN
- d. Repair date
- e. Vehicle mileage at time of repair
- f. Repairing dealer's or facility's name, telephone number, city and state or ZIP code
- g. Labor operation number(s)
- h. Problem code(s)
- i. Replacement part number(s) and description(s)
- j. Concern stated by customer
- k. Comment, if any, by dealer/technician relating to claim and/or repair

A.5. The Microsoft Access file named "WARRANTY DATA.mdb" provided in this mailing contains the above information in the format requested. Among the total 1,299 warranty claims for the 2001 and 2002 model year Montero are 918 claims for old parts before recall launch and 276 claims for new countermeasure parts. Mitsubishi will discuss this further in our response to Question Number 14, which will be provided on or before August 24, 2006.

Q.6. Describe in detail the search criteria used by Mitsubishi to identify the claims identified in response to Request No. 5, including the labor operations, problem codes, part number and any other pertinent parameters used. Provide a list of all labor operations, labor operation descriptions, problem codes, and problem code descriptions applicable to the alleged defect in the subject vehicles. State, by make and model year, the terms of the new vehicle warranty coverage offered by Mitsubishi on the subject vehicles (i.e., the number of months and mileage for which coverage is provided and the vehicle systems that are covered). Describe any extended warranty coverage option(s) that Mitsubishi offered for the subject vehicles and state by option, model, and model year, the number of vehicles that are covered under each such extended warranty.

A. 6. Search criteria used:

- ◆ 2001 and 2002 model year Montero models
- ◆ Labor Operations beginning with "35" (our group number designation for Brakes)
- ◆ Part numbers MR527718, MR977411, MR977223, and 4630A011

Labor operation numbers and labor operation descriptions applicable to the alleged defect in the subject vehicles are:

LABOR OPERATION NO.	DESCRIPTION
35000094	SERVICE BRAKES AIR BLEED
35121010	BRAKE BOOSTER ASSEMBLY REPL
35131000	HYDRAULIC BRAKE BOOSTER ASSEMBLY
35131010	HYDRAULIC BRAKE BOOSTER ASSEMBLY REPL
35131110	RESERVOIR TANK ASSY(HBB) REPL
35131310	HYDRAULIC BRAKE BOOSTER MASTER CYLINDER REPL
35131400	HYDRAULIC BRAKE BOOSTER ACCUMULATOR
35131410	HYDRAULIC BRAKE BOOSTER ACCUMULATOR R&R
35131510	HYDRAULIC BRAKE BOOSTER LEAD WIRE REPL
35131600	HYDRAULIC BRAKE BOOSTER PUMP MOTOR
35131610	HYDRAULIC BRAKE BOOSTER PUMP MOTOR REPL
35131710	MASTER CYLINDER&HYDRAULIC UNIT ASSY(HBB) REPL
35452000	HYDRAULIC UNIT ASSEMBLY
35840410	ABS HYDRAULIC UNIT VALVE RELAY REPL
35850110	ANTI-SKID (ABS) CONTROL UNIT REPL

Problem codes and problem code descriptions applicable to the alleged defect in the subject vehicles listed in the "Nature Code chart" and "Cause Code chart" provided with this mailing.

Terms of the new vehicle warranty coverage offered by Mitsubishi on the subject vehicles are:

- ◆ Basic coverage: 3 years/36,000 miles
- ◆ Powertrain coverage: 5 years/60,000 miles
- ◆ Restraint system coverage: 5 years/60,000 miles
- ◆ Anti-corrosion coverage: 7 years/100,000 miles
- ◆ Emission control system coverage:
 - Federal
 - Defects: Emission-related parts: 3 years/36,000
ECM, TCM, catalytic converter, OBD device: 8 years/80,000 miles
 - Performance: Emission-related parts: 2 years/24,000 miles
ECM, TCM, catalytic converter, OBD device: 8 years/80,000 miles
 - Calif., Mass., Vermont and Maine
 - Defects: Emission-related parts: 3 years/50,000
Long term 1: 7 years/70,000 miles
Long term 2: 8 years/80,000 miles
 - Performance: Emission-related parts: 3 years/50,000 miles
Long term 1: 7 years/70,000 miles
Long term 2: 8 years/80,000 miles

Extended warranty coverage options were not offered directly by Mitsubishi for the subject vehicles.

A.12. The attachment named "Parts Demand" includes the monthly demand for each of the four part numbers identified in A.11 above. The numbers reflect the part that the dealer ordered on his order form, however if a part number is superseded, the newer part is actually the component shipped. Mitsubishi is not able to identify which model or model year the parts sales were for; however only the 2000 and 2001 Mitsubishi Montero equipped with HBB ABS used the subject components.

The Vendor for the subject components is:

Accumulator (original and modified part)

Supplier's name: AISIN SEIKI Co. Ltd.

**Address: 2-1, Asahi-machi, Kariya, Aichi Prefecture
JAPAN 448-8650**

The appropriate contact person will be provided as a portion of our confidential submission, due to the personal information on this individual.

Q.13. MMNA will provide this response on or before August 24, 2006.

Q.14. MMNA will provide this response on or before August 24, 2006.

ATTACHMENT FOR QUESTION 4

- ◆ **CUSTOMER COMPLAINTS – 22 CASES**
- ◆ **FIELD REPORTS (PRODUCT QUALITY REPORTS) – 10 CASES**

FILE NO : 0383291
CONTACT BY : P

PAGE: 1

CUST(L,F,M) : ██████████ OPEN DATE : 04/18/06
 ADDRESS : ██████████ CLOSE DATE: 04/18/06
 CITY : NEWTOWN ST: PA ZIP: ██████████ REOPEN DT :
 VIN : JA4MW51R22J0 ██████████ DLVRY DT : 12/24/01 LAST CLOSE:
 YEAR/MODEL : 02 MONTERO MILEAGE : 62000 LAST PRINT:
 PHONE #S : W ██████████ EXT: TDPP NO: DAYS OPEN: 1
 (W,H,F,C,B) : H ██████████ RECALLS:
 SELL DLR : 39073 FRED BEANS MITS PHONE : 215 340 7950 SRV MGR: DAN GAVIN
 SRV DLR : 39073 FRED BEANS MITS PHONE : 215 340 7950 SRV MGR: DAN GAVIN
 DISTRICT : B3 DSM: PECJ 2778 SPCL : CURR REP: MJAU 1554
 SLFATH: 6 ORIG REP: MJAU 1554

GROUP : 35 SERVICE BRAKES
 SUB-GROUP : 00 SERVICE BRAKES
 CONDITION : 13 INOPERATIVE
 CUST CODE : 24 DENIED OUT OF WARRANTY

GROUP :
 SUB-GROUP :
 CONDITION :
 CUST CODE :

GROUP :
 SUB-GROUP :
 CONDITION :
 CUST CODE :

(04/18/06) (12:10) (MJAU):

SERVICE BRAKES

PREVIOUS FILE(S) :

MECHANICAL ISSUE # 1 : BRAKES FAILED IN GARAGE () PREVIOUS RPRS

MECHANICAL ISSUE # 2 : BRAKE ACCUMULATOR FAILURE () PREVIOUS RPRS

MECHANICAL ISSUE # 3 : () PREVIOUS RPRS

ORIGINAL OWNER: (X) YES; () NO, PURCH MM/YY AT --, --- MILES

POLICY ADJUSTMENT REQUEST ...: () RENTAL; () OUT OF WARR REPAIR ; () OTHER

PARTS DELAY/BACKORDER: () YES ; PART # ; ORDER #

RETAILER SM/ADVISOR CONTACTED: () YES ; NAME :

DPSM CONTACTED: () YES ; NAME :

RECVD CALL FROM CUSTOMER, STATES BACKING OUT OF GARGE AND BRAKES DID NOT WORK. STATES TOOK VEH TO FRED BEANS MITSU AND ADVISED BRAKE ACCUMULATOR FAILED. CUST CONCERNED AS SHE SAW A RECALL FOR BRAKE ACCUMULATOR FOR THE SAME MODEL YEAR AND SEEKING ASSISTANCE FROM MMNA.

VCM ADVISED CUSTOMER HER VEH WAS NOT INVOLVED IN THE RECALL CAMPAIGN AND ALL REPAIRS ARE CUSTOMER PAY AS VEH IS OOW.

CUST DISSATISFIED AND STATES WILL TAKE THAT INTO CONSIDERATION WHEN PURCHASING HER NEXT VEH. OPEN RECALL FOR FUEL LEVELER WAS COMPLETED PER CUST

04/18/06 MJAU:FILE CLOSED

 U.S. Department of Transportation National Highway Traffic Safety Administration		DOT Auto Safety Hotline Vehicle Owner's Questionnaire To Report Vehicle Safety Defects 1-888-DASH-2-DOT (1-888-327-4236) INTERNET:www.nhtsa.dot.gov/hotline		FOR AGENCY USE ONLY 100148	
		Date Received 18-APR-2006	Repository <input type="checkbox"/>	Reference No. 10155605	
OWNER INFORMATION (Type or Print)					
Name		Daytime Telephone Number		E-mail Address	
Address		Evening Telephone Number			
City NEWTOWN	State PA	Zip Code			
Do you authorize NHTSA to provide a copy of this report to the manufacturer of your vehicle? <input checked="" type="checkbox"/> YES <input type="checkbox"/> NO In the absence of an authorization, NHTSA WILL NOT provide your name or address to the vehicle manufacturer.					
Signature of Owner		Date			
VEHICLE INFORMATION					
17 digit Vehicle Identification Number Located at bottom of windshield on driver's side JA4MW51R22J		Make MITSUBISHI	Model MONTERO	Model Year 2002	
Date Purchased 21-DEC-01	Dealer's Name and Telephone Number FRED BEANS MITSUBISHI		Engine: No: Cylinders 6	Fuel Type: Gas	
Original Owner <input checked="" type="checkbox"/>	Dealer's City DOYLESTOWN	State PA	Zip Code		
Transmission Type AUTOMATIC	<input checked="" type="checkbox"/> Antilock Brakes <input checked="" type="checkbox"/> Cruise Control	Powertrain 4 WHEEL DRIVE	Vehicle Component Code 033100 SERVICE BRAKES, HYDRAULIC:POWER ASSIST:VACUUM		
Multiple Failure: 1					
FAILED COMPONENT(S)/PART(S) INFORMATION					
Incident Date(s) 14-APR-2006	Failure Mileage 62000	Failure Speed 5			
ADDITIONAL ITEMS TO BE COMPLETED WHEN REPORTING A TIRE FAILURE					
Tire Make	Tire Model (Name or Number)		Tire Size (Example P215/65R15)		
DOT No. (Example: DOTM4S9ABC036)	<input type="checkbox"/> Original Equipment <input type="checkbox"/> Prior Repair	Failure Location:			
Tire Component Code			Tire Failure Type		
ADDITIONAL ITEMS TO BE COMPLETED WHEN REPORTING A CHILD SEAT FAILURE					
Make:	Date Manufactured:	Model No./Name:			
Seat Type:	Installation System:				
Child Seat Component Code:	Failed Part:				
APPLICABLE INCIDENT INFORMATION					
<i>(Please describe in detail the incident(s), failure(s), crash(es), and injury(ies).)</i>					
Crash <input type="checkbox"/> Yes <input checked="" type="checkbox"/> No	Fire <input type="checkbox"/> Yes <input checked="" type="checkbox"/> No	Number of Persons Injured 0	Number of Deaths 0	Reported to Police N	
Narrative Description of Incident(s), Crash(es), and Injury(ies). Please describe (1) events leading up to the failure, (2) failure and its consequences, and (3) what was done to correct the failure; i.e., parts repaired or replaced (and if old part is available).					
I STARTED MY TRUCK, PUT IT IN REVERSE AND ATTEMPTED TO APPLY THE BRAKES. THERE WAS A LOUD GRINDING SOUND AND NO BRAKES--JUST A DEAD PEDAL. I WAS ABLE TO STOP THE TRUCK BY APPLYING THE EMERGENCY BRAKE--WITH ONLY INCHES TO SPARE BEFORE ROLLING THROUGH MY GARAGE. I HAD THE TRUCK TOWED TO THE DEALERSHIP--THEY CALLED TO TELL ME THE PROBLEM WAS WITH THE ACCUMULATOR. I CHECKED ON THIS WEBSITE TO SEE IF THEIR WERE ANY RECALLS--AND FOUND ONE (01V2S4001) THAT DESCRIBED THE PROBLEM EXACTLY. HOWEVER, THE DEALERSHIP TOLD ME THAT MY VIN WAS NOT INCLUDED IN THIS RECALL, THAT THE REPLACEMENT WAS MY RESPONSIBILITY, AND REFERRED ME TO THE MANUFACTURER. THE MANUFACTURER WAS EQUALLY HELPFUL. I WANTED TO REPORT THIS TO THE NHTSA IN CASE OTHER VEHICLES IN THE RECALL YEAR THAT AREN'T INCLUDED IN THIS RECALL ARE NOTIFIED THAT THIS COULD BE A PROBLEM. I FEEL REALLY LUCKY THAT MY KIDS (AGES 3 1/2 AND 6 MONTHS) WEREN'T IN THE TRUCK WITH ME AND THAT NOBODY WAS HURT. *JB					
Include, if available: Police/Fire Department Report, Photos, and Repair Invoice.			ATTACH ADDITIONAL SHEETS IF NECESSARY		
<small>The Privacy Act of 1974-Public Law 93-579 This information is requested pursuant to authority vested in the National Highway Traffic Safety Act and subsequent amendments. You are under no obligation to respond to this questionnaire. Your response may be used to assist the NHTSA in determining whether a Manufacturer should take appropriate action to correct a safety defect. If the NHTSA proceeds with administrative enforcement or litigation against a manufacturer, your response, or a statistical summary thereof, may be used in support of the agency's action.</small>					

FILE NO : 0366378
CONTACT BY : P

PAGE: 1

CUST(L,F,M): ██████████ OPEN DATE : 02/23/05
 ADDRESS : ██████████ CLOSE DATE: 02/23/05
 CITY : HERNDON ST: VA ZIP: ██████████ REOPEN DT : 02/28/05
 VIN : JA4MW31R12 ██████████ DLVRY DT : 12/29/01 LAST CLOSE: 03/03/05
 YEAR/MODEL : 02 MONTERO MILEAGE : 73000 LAST PRINT: 02/28/05
 PHONE #S : W ██████████ EXT: TDPP NO: DAYS OPEN: 4
 (W,H,F,C,B): H ██████████ RECALLS:
 SELL DLR : 46059 CARMAX MITS-DUL PHONE : *** ** *SRV MGR: *TERMINATED*
 SRV DLR : 46001 STOHLMAN MITS. PHONE : 703 448 9300 SRV MGR: PHIL PULLEN
 DISTRICT : B4 DSM: ADAW 2778 SPCL : CURR REP: KEGE 1577
 SLFATH: 6 ORIG REP: MERT 1575

GROUP : 35 SERVICE BRAKES
 SUB-GROUP : 00 SERVICE BRAKES
 CONDITION : 13 INOPERATIVE
 CUST CODE : Z3 PROVIDED PART/VEHICLE/CORP INF

GROUP :
 SUB-GROUP :
 CONDITION :
 CUST CODE :

GROUP :
 SUB-GROUP :
 CONDITION :
 CUST CODE :

(02/23/05) (10:21) (MERT):

SERVICE BRAKES

PREVIOUS FILE(S) :

MECHANICAL ISSUE # 1 : HYDRAULIC BRAKE BOOSTER ACCUMULATOR () PREVIOUS RPRS
MECHANICAL ISSUE # 2 : () PREVIOUS RPRS
MECHANICAL ISSUE # 3 : () PREVIOUS RPRS
ORIGINAL OWNER: () YES; () NO, PURCH MM/YY AT --, --- MILES
POLICY ADJUSTMENT REQUEST ...: () RENTAL; () OUT OF WARR REPAIR ; () OTHER
PARTS DELAY/BACKORDER: () YES ; PART # ; ORDER #
RETAILER SM/ADVISOR CONTACTED: () YES ; NAME :
DPSM CONTACTED: () YES ; NAME :

CUST CALLED STATING THAT HIS BRAKES FAILED AND HAD VEH TOWED TO LOCAL INDEP SHOP WHERE HE WAS TOLD THAT MMNA HAS A RECALL ON THE VEH. CUST SAID HE EVEN CALLED NHTSA AND WAS TOLD THAT YES MMNA HAS A RECALL OUT ON THE HBB. VCM PULLED RECALL AND INFORMED CUST THAT VEH AFFECTED BY THE RECALL CAMPAIGN WERE PRODUCED BEFORE 6/20/01 AND HIS VEH WAS PRODUCED 10/24/01 AND WAS NOT INCLUDED IN THE RECALL. CUST SAID THAT HE HAS A COPY OF THE RECALL AND HE EXPERIENCED THE SAME THING. VCM INFORMED CUST OF CURRENT OPEN RECALL. CUST SAID HE WAS DECLINED ASSISTANCE FROM 46001, BUT WILL RE-CONTACT TO SEE IF SM CAN REVIEW FURTHER WITH AREA REP.

02/23/05 MERT:FILE CLOSED

(02/28/05) (13:40) (KEGE):

THE CUST CALLED BACK TO ARGUE THAT HIS VEH WAS INVOLVED IN THE RECALL, THE HYDRAULIC BOOST ACC FAILED. THE CUST STATES THAT HIS BRAKES FAILED AND THERE WAS A NOISE COMING FROM THE DASH BOARD. THE CUST WANTS THIS VEH REPAIRED UNDER THE RECALL. THE VEH HAS NOT BEEN DIAGNOSED BY A MIT RTLR. THE CUST WAS ADVISED TO TAKE HIS VEH TO A MIT RTLR FOR DIAGNOSES, THE CUST WANTS MMNA TO PAY FOR THE TOW AND THE REPAIRS. VCM ADVISED THE CUST THAT HIS VEH WAS NOT DIAGNOSED BY A MIT RTLR AND THEREFORE NO ASSIST CAN BE OFFERED. THE CUST STATES HE SPOKEN TO THE RTLR BUT NOTHING HAS COME OF THAT. THE CUST WILL TOW TO RTLR WITH NO GUARANTEES GIVE AS FAR AS ASSISTANCE.

RETAILER SERVICE MANAGER, PLEASE REVIEW AND FOLLOW-UP AS FOLLOWS:

- 1. HI PHIL, THIS CUST IS COMING FOR DIAGNOSES ON THE BRAKE HYDRAULIC BOOSTER. THINKS SHOULD BE COVERED UNDER RECALL OR WARRANTY
2. PLEASE SCHEDULE APPOINTMENT FOR THIS CUST AND THEN REVIEW WITH THE DPSM
3. PLEASE PROVIDE A DETAILED CLOSING

OLD REP WAS = MERT, NEW REP IS = KEGE

FILE WAS REOPENED (02/28/05) (KEGE)

DEALER PRINT, (02/28/05) (14:03) (KEGE)

***** THANK YOU FOR YOUR ASSISTANCE IN RESOLVING OUR CUSTOMERS ISSUE. *****
***** IF YOU HAVE ANY QUESTIONS ABOUT THE FILE, CONTACT *****
***** CUSTOMER CONNECTIONS AT 888-908-6672 TO SPEAK WITH A *****
***** VEHICLES CASE MANAGER. *****
***** CUSTOMER SATISFACTION AND RETENTION IS OUR FIRST PRIORITY! *****

&*****
&DATE CUSTOMER CONTACTED : 03/01/2005 DATE COMMENTS ENTERED: 03/01/2005
&CONTACTED BY : PHIL P.
&CUSTOMER APPOINTMENT DATE :
&DPSM INSPECTION PENDING : NO DATE:
&BACK ORDERED PART # (S) :
&PARTS ORDER D-S-SHO # (S) :
&TECHLINE ASSISTANCE PENDING : NO IF YES, RESOLUTION IN SUMMARY
&SUMMARY OF CONTACT :
&SERVICE MANAGER CALLED CUST. AT HOME AND WORK PHONE #'S, LEFT MESSAGE ASKING
&CUST. TO CALL STOHLMAN TO SET A APPT. TO GET MONTERO CHECKED OUT, AS PER CUS
&. AND MMSA
&*****
&DEALER COMMENTS TRANSMITTED ON (03/01/2005)(46001SER)
&FILE UPDATED AS A RESULT OF TRANSMISSION
&*****
&DATE REPAIR COMPLETED OR DECISION RENDERED : 03/03/2005
&REPAIR ORDER NUMBER : 67114
&MILEAGE AT REPAIR : 73585
&COMMENTS INPUT BY : PHIL P.
&ACTION TAKEN :
&SERVICE MANAGER SPOKE TO DPSM ON 3-1-05, DECISION WAS TO WARR. GOODWILL THE
&ART (BRAKE ACCUMALATOR) AND CUST. TO PAY FOR LABOR FOR INSTALLATION OF PART.
&CUST. O.K.ED DECISION. STOHLMAN INSTALLED PART ON 3-3-05. CONCERN RESOLVED.
&ERVICE MANAGER CALLED CUST. AFTERNOON OF 3-3-05 AND INFORMED HIM MONTERO IS
&EADY. CUST. TO PICK UP ON FRIDAY 3-4-05.
&*****
&DEALER COMMENTS TRANSMITTED ON (03/03/2005)(46001SER)
&FILE CLOSED AS A RESULT OF TRANSMISSION
&*****

 U.S. Department of Transportation National Highway Traffic Safety Administration		DOT Auto Safety Hotline Vehicle Owner's Questionnaire To Report Vehicle Safety Defects 1-888-DASH-2-DOT (1-888-327-4236) INTERNET: www.nhtsa.dot.gov/hotline		FOR AGENCY USE ONLY 100248	
		Date Received 18-FEB-2005		Repository <input type="checkbox"/> Reference No. 10111753	
OWNER INFORMATION (Type or Print)					
Name		Daytime Telephone Number		E-mail Address	
Address		Evening Telephone Number			
City	HERNDON	State	VA	Zip Code	
Do you authorize NHTSA to provide a copy of this report to the manufacturer of your vehicle? <input type="checkbox"/> YES <input checked="" type="checkbox"/> NO In the absence of an authorization, NHTSA WILL NOT provide your name or address to the vehicle manufacturer.					
Signature of Owner		Date			
VEHICLE INFORMATION					
17 digit Vehicle Identification Number Located at bottom of windshield on driver's side		Make	Model	Model Year	
JA4MW31R12		MITSUBISHI	MONTERO	2002	
Date Purchased	Dealer's Name and Telephone Number		Engine: No: Cylinders	Fuel Type:	
			6	Gas	
Original Owner	Dealer's City		State	Zip Code	
<input checked="" type="checkbox"/>					
Transmission Type	<input checked="" type="checkbox"/> Antilock Brakes	Powertrain	Vehicle Component Code		
AUTOMATIC	<input checked="" type="checkbox"/> Cruise Control	4 WHEEL DRIVE	033000 SERVICE BRAKES, HYDRAULIC: POWER ASSIST		
		Multiple Failure: 1			
FAILED COMPONENT(S)/PART(S) INFORMATION					
Incident Date(s)	Failure Mileage	Failure Speed			
17-FEB-2005					
ADDITIONAL ITEMS TO BE COMPLETED WHEN REPORTING A TIRE FAILURE					
Tire Make	Tire Model (Name or Number)		Tire Size (Example P215/65R15)		
DOT No. (Example: DOTM19ABC036)	<input type="checkbox"/> Original Equipment <input type="checkbox"/> Prior Repair		Failure Location:		
Tire Component Code		Tire Failure Type			
ADDITIONAL ITEMS TO BE COMPLETED WHEN REPORTING A CHILD SEAT FAILURE					
Make:	Date Manufactured:		Model No./Name:		
Seat Type:	Installation System:				
Child Seat Component Code:	Failed Part:				
APPLICABLE INCIDENT INFORMATION					
<i>(Please describe in detail the incident(s), failure(s), crash(es), and injury(ies).)</i>					
Crash <input type="checkbox"/> Yes <input checked="" type="checkbox"/> No	Fire <input type="checkbox"/> Yes <input checked="" type="checkbox"/> No	Number of Persons Injured	Number of Deaths	Reported to Police	
		0	0	N	
Narrative Description of Incident(s), Crash(es), and Injury(ies). Please describe (1) events leading up to the failure, (2) failure and its consequences, and (3) what was done to correct the failure; i.e. parts repaired or replaced (and if old part is available).					
NHTSA RECALL CAMPAIGN 01V250001; MITSUBISHI ISSUED A BRAKE BOOSTER RECALL. THIS VEHICLE WAS NOT INCLUDED IN THE RECALL DUE TO VIN, BUT THE DASHBOARD WAS MAKING NOISE WHILE THE VEHICLE WAS GOING UP A HILL. THE BRAKES WERE APPLIED AND FAILED. *AK					
Include, if available: Police/Fire Department Report, Photos, and Repair Invoice.			ATTACH ADDITIONAL SHEETS IF NECESSARY		
<small>The Privacy Act of 1974-Public Law 93-579 This information is requested pursuant to authority vested in the National Highway Traffic Safety Act and subsequent amendments. You are under no obligation to respond to this questionnaire. Your response may be used to assist the NHTSA in determining whether a manufacturer should take appropriate action to correct a safety defect. If the NHTSA proceeds with administrative enforcement or litigation against a manufacturer, your response, or a statistical summary thereof, may be used in support of the agency's action.</small>					

(09/20/04) (07:55) (LEMD):

SERVICE BRAKES

PREVIOUS FILE(S) :

MECHANICAL ISSUE # 1 : BRAKE CONCERNS () PREVIOUS RPRS

MECHANICAL ISSUE # 2 : () PREVIOUS RPRS

MECHANICAL ISSUE # 3 : () PREVIOUS RPRS

ORIGINAL OWNER: (X) YES; () NO, PURCH MM/YY AT --,--- MILES

POLICY ADJUSTMENT REQUEST ...: () RENTAL;() OUT OF WARR REPAIR ; () OTHER

PARTS DELAY/BACKORDER: () YES ; PART # ; ORDER #

RETAILER SM/ADVISOR CONTACTED: () YES ; NAME :

DPSM CONTACTED: () YES ; NAME :

***** SERVICE DCOA *****

REASON: () UNRESOLVED CONCERN/REPEAT VISITS

() NEW MECHANICAL ISSUE; MULTIPLE VEHICLE CONCERNS.

() DEALER UNABLE TO DUPLICATE; SYMPTOM:

() DEALER DECLINING WARRANTY REPAIRS; REASON:

VERIFIED: (N/A) SERVICING DEALER'S NAME OR NUMBER

(N/A) NAME OF CUST'S SERVICE ADVISOR OR MANAGER

VEH AT DLR () YES; (X) NO

DEALER SERVICE MANAGER, PLEASE RESOLVE

1. PLS REVIEW WITH YOUR GM, TECH-LINE AND YOUR DPSM IF NEEDED TO DETERMINE ACTION TO BE TAKEN.

2. PLS CALL CUST WITH ACTION PLAN AND SET-UP APPT IF NOT ALREADY SCHEDULED.

3. PLS UPDATE FILE WITH FINDINGS AND ANY ACTION TAKEN AND CLOSE THE FILE.

CUST CALLING TO VEF IF HER VEH HAS OPEN RECALL ASSOCIATED TO BRAKES. VCM ADV

'D CUST ONLY OPEN RECALL ON HER VEH IS FOR C0408W (FUEL LEVELER). CUST STATED

THAT SHE WOULD A RECALL ON HER VEH ASSOCIATED TO BRAKES. VCM TRIED TO EXPLAIN

TO CUST RECALLS SPECIFY VEH BUILT BETWEEN A CERTAIN TIME PERIOD. VCM ASSURED

CUST THAT HER VEH HAD NO BRAKE RECALL. VCM SUGGESTED THAT SHE TAKE VEH TO DLR

TO INSPEC IF SHE FELT VEH HAD BRAKE PROBLEMS. CUST STATED DLR WILL NOT DO FOR

FREE. VCM ADV'D CUST THERE WOULD BE DIAGNOSTIC FEE. CUST FEELS SHOULD BE MITS

U RESPONSIBILITY. CUST NOT HAPPY AND ASKED FOR VCM'S NAME. VCM GAVE.

09/20/04 LEMD:FILE CLOSED

 U.S. Department of Transportation National Highway Traffic Safety Administration		DOT Auto Safety Hotline Vehicle Owner's Questionnaire To Report Vehicle Safety Defects 1-888-DASH-2-DOT (1-888-327-4236) INTERNET:www.nhtsa.dot.gov/hotline		FOR AGENCY USE ONLY 1220	
		Date Received 22-JUL-2005		Repository <input type="checkbox"/> Reference No. 10092744	
OWNER INFORMATION (Type or Print)					
Name		Daytime Telephone Number		E-mail Address	
Address		Evening Telephone Number			
City	State	Zip Code			
MINOA	NY				
Do you authorize NHTSA to provide a copy of this report to the manufacturer of your vehicle? <input type="checkbox"/> YES <input checked="" type="checkbox"/> NO In the absence of an authorization, NHTSA WILL NOT provide your name or address to the vehicle manufacturer. Signature of Owner _____ Date ____/____/____					
VEHICLE INFORMATION					
17 digit Vehicle Identification Number Located at bottom of windshield on driver's side		Make	Model	Model Year	
JA4MW31R82		MITSUBISHI	MONTERO	2002	
Date Purchased	Dealer's Name and Telephone Number		Engine:	Fuel Type:	
30-OCT-02	ROGER BURDICK MITSUBISHI 315-453-9901		No: Cylinders	Gas	
Original Owner	Dealer's City	State	Zip Code		
<input type="checkbox"/>	CICERO	NY	13039		
Transmission Type	<input checked="" type="checkbox"/> Antilock Brakes	Powertrain	Vehicle Component Code		
AUTOMATIC	<input checked="" type="checkbox"/> Cruise Control		033100 SERVICE BRAKES, HYDRAULIC:POWER ASSIST:VACUUM		
			Multiple Failure: 1		
FAILED COMPONENT(S)/PART(S) INFORMATION					
Incident Date(s)	Failure Mileage	Failure Speed			
01-OCT-2003	5535	25			
ADDITIONAL ITEMS TO BE COMPLETED WHEN REPORTING A TIRE FAILURE					
Tire Make		Tire Model (Name or Number)		Tire Size (Example P215/65R15)	
DOT No. (Example: DOTM1A9ABC036)		<input type="checkbox"/> Original Equipment	Failure Location:		
		<input type="checkbox"/> Prior Repair			
Tire Component Code				Tire Failure Type	
ADDITIONAL ITEMS TO BE COMPLETED WHEN REPORTING A CHILD SEAT FAILURE					
Make:		Date Manufactured:	Model No./Name:		
Seat Type:		Installation System:			
Child Seat Component Code:		Failed Part:			
APPLICABLE INCIDENT INFORMATION					
<i>(Please describe in detail the incident(s), failure(s), crash(es), and injury(ies).)</i>					
Crash	Fire	Number of Persons Injured	Number of Deaths	Reported to Police	
<input checked="" type="checkbox"/> Yes <input type="checkbox"/> No	<input type="checkbox"/> Yes <input checked="" type="checkbox"/> No			Y	
Narrative Description of Incident(s), Crash(es), and Injury(ies). Please describe (1) events leading up to the failure, (2) failure and its consequences, and (3) what was done to correct the failure; i.e., parts repaired or replaced (and if old part is available).					
THE CONSUMER EXPERIENCED THE SAME PROBLEM AS STATED IN RECALL 01V254001. THE BRAKE PEDAL WENT COMPLETELY TO THE FLOOR UPON TRYING TO STOP. *AK ULTIMATELY, THE CONSUMER HAD AN ACCIDENT AS A RESULT OF THE BRAKE FAILURE. THE CONSUMER STATED HE RECEIVED A RECALL NOTICE IN THE MAIL, HOWEVER THE MANUFACTURER STATED THE CONSUMERS VEHICLE WAS NOT A PART OF THE RECALL.*JB					
Include, if available: Police/Fire Department Report, Photos, and Repair Invoice. ATTACH ADDITIONAL SHEETS IF NECESSARY					
<small>The Privacy Act of 1974 (Public Law 93-579) This information is requested pursuant to authority vested in the National Highway Traffic Safety Act and subsequent amendments. You are under no obligation to respond to this questionnaire. Your response may be used to assist the NHTSA in determining whether a manufacturer should take appropriate action to correct a safety defect. If the NHTSA proceeds with administrative enforcement or litigation against a manufacturer, your response, or a statistical summary thereof, may be used in support of the agency's action.</small>					

MATCHING CUSTOMER SERVICE CONTACT

NAME: [REDACTED] SC: [REDACTED] OPEN DATE: 20010507
 ADDRESS: [REDACTED] FILE NO: 0285065
 PHONE (W): [REDACTED] EXT: [REDACTED] PHONE (H): [REDACTED]
 VIN: JA4MW51R91J000777 YEAR/MODEL: 2001 MONTERO
 SERV DLR: 41045 D.BRKS MIT-SPTN
 DELIVERY DATE: 09/08/00 MILEAGE: 11000 CLOSE DATE: 20010716
 GRP/SUB-GRP: SERVICE BRAKES BOOSTER, BRAKE, GENERAL
 COND/REMEDY: OPERATIONAL CONCERN
 REASON FOR CONTACT: REOPEN DT: OPEN CLOSE
 050701//KIEG

***** CUSTOMER/CALLER STATES THE FOLLOWING: *****
 MECHANICAL ISSUE #1.....: BRAKE BOOSTER NEEDED-BRAKES FAILED?
 MECHANICAL ISSUE #2.....: ALLEGED BODY DAMAGE-DOOR MOLDING BROKEN
 MECHANICAL ISSUE #3.....: COOLANT LEAKING
 MULTIPLE REPAIRS OF ABOVE ISSUE(S): PAST VISITS..NO REPAIRS.
 INTERMITTENT MECHANICAL ISSUE(S)..
 VEHICLE AT RETAILER.....: YES
 SM/ADVISOR CONTACTED(INCLUDE NAME): GM,TIM & SM,SHAWN.
 DPSM CONTACTED.(CELL PHONE OR VM):
 RETAILER APPOINTMENT DATE/TIME....
 TRADE/REPURCHASE REQUEST.....: YES
 EMAIL TO CR/MEDIATION BOX.....:
 NCDS BROCHURE SENT.....:
 GOODWILL ASSISTANCE REQUEST.....:
 ORIGINAL OWNER.....: YES
 MAINTENANCE RECORDS AVAILABLE.....:
 MULTIPLE/REPEAT MITSU OWNER.....:
 RENTAL REQUEST.....:
 PARTS ORDERING DELAY.....:
 REIMBURSEMENT REQUEST.....:
 SALES/FINANCE RELATED ISSUES.....: FEELS VEH DAMAGED PRIOR TO SALE
 RETAILER COMPLAINT.....: YES. STATES ALLEGED DAMAGE NOT DISCLOSED
 CALLER IS THE VEHICLE OWNER.....: YES
 LETTER REQUEST.....:
 MISCELLANEOUS.....:
 MISCELLANEOUS.....:

---SHORT NARRATIVE---

CUSTOMER CALLS MMSA AND REFERENCES OVERALL DISSATISFACTION WITH INITIAL PRODUCT QUALITY. CUSTOMER ALLEGES BRAKES "WENT OUT" ON SPOUSE THE OTHER DAY AND BARELY AVERTED ACCIDENT. IN ADDITION CUSTOMER CONTENDS DOOR MOLDING ON RT REAR DOOR IS CUT AND SUSPECTS VEHICLE WAS INVOLVED IN ACCIDENT BUT WAS NEVER DISCLOSED PRIOR TO SALE. CUSTOMER MAINTAINS HE SPOKE WITH GM WHO REFERRED HIM BACK TO MMSA RECOMMENDING HE PURSUE "SUBSTITUTION OF COLLATERAL." CSA ADVISED CUSTOMER IT WAS HIGHLY UNLIKELY MMSA WOULD PARTICIPATE IN VEHICLE REPLACEMENT AT THIS TIME AS NOT JUSTIFIED BY WARRANTY HISTORY. CSA DID AGREE TO REVIEW COMMENTS WITH GM AND VREPAIR EFFORTS WITH SM. CSA CONTACTED GM, WHO DENIED VEHICLE WAS INVOLVED IN PAST ACCIDENT(SOLD AS DEMO WITH APPROX 4K MILES) & "SUBSTITUTION"COMMENT MADE WITH THE PROVISO VEHICLE HAS CONTINUED PROBLEMS. CSA SPOKE WITH SM AND BOOSTER NEEDS TO BE REPLACED. SHAWN CHECKING ON PARTS STATUS. DOOR GASKET IS CUT AND WILL BE REPLACED. NO COOLANT LEAK DETECTED BUT SYSTEM WILL BE PRESSURIZED AND CHECKED. SHAWN WILL PERFORM WARRANTY REPAIRS AND INFORM DPSM OF DEVELOPMENTS. SHAWN STATES NO PAST R.O.'S FOR ANY COMPLAINTS NOTED ABOVE.

 RETAILER: 1) SHAWN...PLEASE THOUGHTFULLY ADDRESS ABOVE PRODUCT ISSUES.
 2) PLEASE CONTACT DPSM AND OBTAIN HIS ASSISTANCE LOCATING PARTS IF NEED BE.

| CONTINUATION OF FILE NO.: 0285045 |

REASON FOR CONTACT: REOPEN DT: OPEN CLOSE

3) PLEASE CONTACT CUSTOMER AND EXPLAIN NEEDED REPAIRS TO VEHICLE.
4) PLEASE UPDATE FILE DETAILING THE RESULTS OF DPSM INVOLVEMENT. PLEASE
SPECIFY DIAGNOSTIC FINDINGS AND ALL REPAIRS MADE. THANKS SHAWN

DEALER PRINT, (05/07/01) (KIEG)

OUR CUSTOMERS THANK YOU FOR YOUR HELP *****
(GREG KIERNAN), (800)464-3535 EXT.(5795) *****
CUSTOMER SATISFACTION AND RETENTION IS OUR FIRST PRIORITY *****

&DATE REPAIR COMPLETED OR DECISION RENDERED : 07/16/2001
&REPAIR ORDER NUMBER : 0
&MILEAGE AT REPAIR : 0
&COMMENTS INPUT BY : 0
&ACTION TAKEN :
&DEALER GM(SHELTON) HAS AGREE TO REPURCHASE VEHICLE BACK FROM CUSTOMER AT THIS
& TIME.

&DEALER COMMENTS TRANSMITTED ON (07/16/01), (U41045B)
&FILE CLOSED AS A RESULT OF TRANSMISSION

MATCHING CUSTOMER SERVICE CONTACT

NAME : [REDACTED] OPEN DATE: 20010720
 ADDRESS : [REDACTED] NAPERVILLE IL [REDACTED] FILE NO: 0290724
 PHONE (W) : [REDACTED] EXT: 110 PHONE (H) : [REDACTED]
 VIN : JA4MW51R81[REDACTED] YEAR/MODEL: 2001 MONTERO
 SERV DLR : 15069 CORONET MITS
 DELIVERY DATE: 07/18/00 MILEAGE: 18000 CLOSE DATE: 20010723
 GRP/SUB-GRP: SERVICE BRAKES BOOSTER, BRAKE, GENERAL
 COND/REMEDY: MISCELLANEOUS

REASON FOR CONTACT: REOPEN DT: OPEN CLOSE
 ***** CUSTOMER/CALLER STATES THE FOLLOWING: *****

- MECHANICAL ISSUE #1..... ACCUMULATOR NEEDED-ABS FAILURE
- MECHANICAL ISSUE #2.....
- MECHANICAL ISSUE #3.....
- MULTIPLE REPAIRS OF ABOVE ISSUE(S): NO
- INTERMITTENT MECHANICAL ISSUE(S):
- VEHICLE AT RETAILER..... YES
- SM/ADVISOR CONTACTED(INCLUDE NAME):
- DPSM CONTACTED.(CELL PHONE OR VM).. VM TO DPSM
- RETAILER APPOINTMENT DATE/TIME....
- TRADE/REPURCHASE REQUEST..... YES
- EMAIL TO CR/MEDIATION BOX.....
- NCDS BROCHURE SENT.....
- GOODWILL ASSISTANCE REQUEST.....
- ORIGINAL OWNER..... YES
- MAINTENANCE RECORDS AVAILABLE.....
- MULTIPLE/REPEAT MITSU OWNER.....
- RENTAL REQUEST.....
- PARTS ORDERING DELAY.....
- REIMBURSEMENT REQUEST.....
- SALES/FINANCE RELATED ISSUES.....
- RETAILER COMPLAINT.....
- CALLER IS THE VEHICLE OWNER..... YES
- LETTER REQUEST.....
- MISCELLANEOUS.....
- MISCELLANEOUS.....

-----SHORT NARRATIVE-----
 CUSTOMER CALLS MMSA AND STATES BRAKES FAILED WHEN HIS WIFE WAS BACKING OUT OF GARAGE AND RETAILER HAS DETERMINED ABS BRAKE ACCUMULATOR AT FAULT. CUSTOMER FEELS VEHICLE UNSAFE AND ADEAMT MMSA REPLACE OR REPURCHASE HIS VEHICLE. CSA CORDIALLY EXPLAINED ACCUMULATOR REPLACEMENT HAS SUCCESSFULLY CORRECTED THIS CONCERN AND LIKLIHOOD OF SUBSEQUENT PROBLEM REMOTE. FURTHER EXPLAINED TO CUSTOMER THAT VEHICLE DID NOT APPEAR TO MEET OBJECTIVE CRITERIA FOR REPLACEMENT/REPURCHASE GIVEN THIS IS THE FIRST BRAKE RELATED INCIDENT. CUSTOMER REMAINED UNFLAPPABLE AND REQUESTED ESCALATION OF MATTER. CSA AGREED TO NOTIFY DPSM OF REQUEST AND ASSURED HIM DEFINITIVE RESPONSE WOULD BE PROVIDED. VM TO DPSM.

 RETAILER: 1) JAMES.. DPSM MAY CONTACT YOU TO DISCUSS BRAKE REPAIR WHICH APPARENTLY IS COMPLETED. PLEASE HAVE DPSM REVIEW CUSTOMER REQUEST FOR REPLACEMENT/REPURCHASE AND CONVEY OR HAVE DPSM CONVEY DEFINITIVE FACTORY POSITION.
 2) PLEASE UPDATE FILE DETAILING BOTH DIAGNOSIS,REPAIRS MADE, AND RESULT OF DPSM INVOLVEMENT. THANKS JAMES

DEALER PRINT, (07/20/01) (KIEG)
 ***** OUR CUSTOMERS THANK YOU FOR YOUR HELP *****

| CONTINUATION OF FILE NO.: 0290724 |

REASON FOR CONTACT: REOPEN DT: OPEN CLOSE

***** (GREG KIERNAN), (800)464-3535 EXT.(5795) *****
***** CUSTOMER SATISFACTION AND RETENTION IS OUR FIRST PRIORITY *****

&DATE REPAIR COMPLETED OR DECISION RENDERED : 07/23/2001
&REPAIR ORDER NUMBER : ██████████
&MILEAGE AT REPAIR : 20401
&COMMENTS INPUT BY : NANETTE
&ACTION TAKEN :
&VEHICLE IS REPAIRED AND BILL WALSH JR IS CONTACTING CUSTOMER IN PERSON
& TO ARRANGE DELIVERY OF CUSTOMER'S VEHICLE
&*****
&DEALER COMMENTS TRANSMITTED ON (07/23/01), (U15069A)
&FILE CLOSED AS A RESULT OF TRANSMISSION
&*****

7.24.01 HUNP:
THE CUST IS REFUSING TO DRIVE THE VEH AGAIN AND STATES HE IS WILLING TO
TO GET INTO ANOTHER MITSU, BUT REFUSES TO DRIVE THIS ONE. VCM ADVISED THE
CUST VEH DOES NOT MEET THE LLAW CRITERIA WITH ONLY ONE REPAIR, BUT CUST
IS INSISTING HE WILL NOT DRIVE VEH AGAIN AND REQUESTED A CALL FROM DPSM.
VCM LEFT VM FOR DPSM, FERB. AT 9:30 PST.
VCM CALLED RTLR AND SPK WITH SM, DIZ, WHO STATES THE VEH IS STILL AT THE
RTLR AND THE GP'S SON IS HANDLING THE CUST CONTACT END. VCM ADVISED DIZ
THAT I LEFT A MSG FOR DPSM RE THE ABOVE.

7/25/2001:DPSM LEFT VOICEMAIL FOR BILL WALSH JR AT 945 AM. DPSM IS FOLLOWING
UP WITH THE GM ON THE DETAILS OF THE STORY TO STAY ON TRACK WITH THE DETAILS
OF THIS FILE BEFORE THE CUSTOEMR IS CONTACTED BY MMSA.

07/25/01//YUNT..CUSTOMER CALLS MMSA UNSURE OF MESSAGE LEFT BY DPSM AND
IS REQUESTING DPSM CALL HIM @630-416-0070 X0110, VCM CALLED AND LEFT
MESSAGE WITH DPSM TO CONTACT CUSTOMER.

7/27/2001:FERB SPOKE TO DAVID K. ABOUT VEHICLE. ABOVE MESSAGE LEFT AT CUST.
HOME WAS NOT LEFT BY DPSM. CUSTOMER STATED TO DPSM THAT HE NO LONGER FEELS
THAT HIS VEHICLE IS SAFE TO DRIVE AND WANTS MMSA TO BUY HIS VEHICLE BACK.
DPSM WANTED TO FIND A RESONABLE SOLUTION WITH THE CUSTOMER ON THIS SITUATION.
DPSM STATED TO CUSTOEMR SINCE HIS VEHICLE HAS ONLY BEEN TO THE DEALERSHIP
ON THIS ONE OCCASSION FOR THIS FIRST TIME REPAIR THAT IT IS NOT ELIGIBLE FOR
A REPURCHASE. CUSTOMER STATED THAT HE WILL NOT BE SATISFIED WITH ANY THING
LESS THAN A BUYBACK. AFTER DPSM SPOKE AGAIN WITH THE SM ON THIS CASE HE
STATED THAT THE ACCUMULATOR FAILED ON THIS MONTERO. THE VEHICLE LOST IT'S
POWER ASSIST BUT STILL HAD WORKING BRAKES. DPSM OFFERED TO CUSTOEMR TO HAVE
DEALER MANAGEMENT AND THE TECH INVOLVED AT TIME OF VEHICLE PICKUP TO EXPLAIN
IN DETAIL THE REPAIRS THAT WERE INVOLVED ON THIS VEHICLE. DPSM THEN OFFERED
TO THE CUSTOMER TO HAVE A FOLLOW UP SAFTY INSPECTION ANYWHERE FROM A FEW
HUNDRED MILES ON THIS VEHICLE TO ASSURE THE CUST THAT HIS VEHICLE IS SAFE
TO DRIVE. DPSM STATED TO CUSTOMER THAT THIS INSPECTION WILL BE DONE AT MMSA
EXPENSE. CUSTOMER STATED THAT THIS ABOVE OFFER WAS AN INSULT AND NOT

| CONTINUATION OF FILE NO.: 0290724 |

REASON FOR CONTACT: REOPEN DT: OPEN CLOSE

ACCEPTABLE. CUSTOMER THEN STATED THAT HE WAS GOING TO FILE LEGAL ACTION ON MMSA FOR THE BUYBACK OF THIS VEHICLE. DPSM TOLD THE CUSTOMER THAT FILING LEGAL ACTION IS A RIGHT HE HAS AND TO DIRECT ANY FUTHER QUESTIONS TO THE CUSTOMER 800 NUMBER IN THE FUTURE.

7/27/2001: FERB CONTACTED BILL WALSH JR (GM) AND TOLD HIM THAT DAVID K. MAY FILE LEGAL ACTION ON THIS VEHICLE. DPSM INFORMED GM THAT THIS VEHICLE IS NOT BEING CONSIDERED AS A BUY BACK CASE.

MATCHING CUSTOMER SERVICE CONTACT

NAME : [REDACTED] OPEN DATE: 20011008
 ADDRESS : [REDACTED] BALTIMORE MD [REDACTED] FILE NO: 0295941
 PHONE (W) : [REDACTED] EXT: [REDACTED] PHONE (H): [REDACTED]
 VIN : JA4MW31R21 [REDACTED] YEAR/MODEL: 2001 MONTERO
 SERV DLR : 21006 OURISMAN MITS.
 DELIVERY DATE: 05/31/00 MILEAGE: 25000 CLOSE DATE: 20011008
 GRP/SUB-GRP: SERVICE BRAKES BOOSTER, BRAKE, GENERAL
 COND/REMEDY: GENERAL COMMENTS
 REASON FOR CONTACT: REOPEN DT: OPEN CLOSE
 100801 VIGV

***** CUSTOMER/CALLER STATES THE FOLLOWING: *****
 MECHANICAL ISSUE #1.....: SQUEAKING NOISE FROM WHEELS
 MECHANICAL ISSUE #2.....: X
 MECHANICAL ISSUE #3.....: X
 MULTIPLE REPAIRS OF ABOVE ISSUE(S): 1X PREVIOUSLY
 INTERMITTENT MECHANICAL ISSUE(S): X
 VEHICLE AT RETAILER.....: NO
 SM/ADVISOR CONTACTED(INCLUDE NAME): X
 DPSM CONTACTED.(CELL PHONE OR VM): X
 RETAILER APPOINTMENT DATE/TIME....: X
 TRADE/REPURCHASE REQUEST.....: X
 EMAIL TO CR/MEDIATION BOX.....: X
 NCDS BROCHURE SENT.....: X
 GOODWILL ASSISTANCE REQUEST.....: X
 ORIGINAL OWNER.....: YES
 MAINTENANCE RECORDS AVAILABLE.....: X
 MULTIPLE/REPEAT MITSU OWNER.....: X
 RENTAL REQUEST.....: X
 PARTS ORDERING DELAY.....: X
 REIMBURSEMENT REQUEST.....: X
 SALES/FINANCE RELATED ISSUES.....: X
 RETAILER COMPLAINT.....: X
 CALLER IS THE VEHICLE OWNER.....: YES
 LETTER REQUEST.....: X
 MISCELLANEOUS.....: X
 MISCELLANEOUS.....: X

-----SHORT NARRATIVE-----
 CUST CALLED VERY IRATE REGARDING RECALLS ON VEHICLE. CUST STATES SAME NOISE IS OCCURING AS A FEW MONTHS AGO AND NOW RCVD NOTICE OF RECALL. VCM ADVISE(ATTEMPTED, SINCE CS KEPT INTERRUPTING) THAT VEHICLE MUST 1ST BE BROUGHT INTO RETAILER FOR DIAGNOSIS AND DETERMINATION IF SAME PROBLEM. CUST HAS NOT CONTACTED RTLR TO ADVISE OF ISSUE. CUST COMPLAINED REGARDING AMOUNT OF TIME SPENT AT RTLR TO ADDRESS ITEMS, BUT NO OTHER PROBLEMS WERE REPORTED OR IN WARRANTY HISTORY. VCM APOLOGIZED FOR TIME DELAY BUT REFER TO RTLR TO HAVE SERVICE PERFORMED. CUST WILL CONTACT RTLR TO REVIEW AND CONFIRM. PART REPLACED IN WARRANTY HISTORY IS DIFFERENT PART# FROM ONE LISTED IN RECALL. CUST DISCONNECTED CALL BEFORE COULD CONFIRM WHICH RTLR CUST WILL CONTACT OR WHEN APPT COULD BE SCHEDULED

 10/08/01 VIGV:FILE CLOSED

MATCHING CUSTOMER SERVICE CONTACT

NAME : [REDACTED] OPEN DATE: 20011008
ADDRESS : [REDACTED] CO : [REDACTED] FILE NO: 0295895
PHONE (W) : [REDACTED] EXT: [REDACTED] PHONE (H): (303) [REDACTED]
VIN : JA4MW51R01 YEAR/MODEL: 2001 MONTERO
SERV DLR : 06034 QUALITY MIT-CO
DELIVERY DATE: 06/15/00 MILEAGE: 31000 CLOSE DATE: 20011009
GRP/SUB-GRP: SERVICE BRAKES BOOSTER, BRAKE, GENERAL
COND/REMEDY: GENERAL COMMENTS
REASON FOR CONTACT: REOPEN DT: OPEN 20011012 CLOSE 20011018
100801 VIGV

***** CUSTOMER/CALLER STATES THE FOLLOWING: *****

- MECHANICAL ISSUE #1.....: QUESTIONS REGARDING RECALL
- MECHANICAL ISSUE #2.....: PREVIOUS BRAKE FAILURE
- MECHANICAL ISSUE #3.....:
- MULTIPLE REPAIRS OF ABOVE ISSUE(S): NO, NEVER VRFD
- INTERMITTENT MECHANICAL ISSUE(S): TAKEN 2X
- VEHICLE AT RETAILER.....: YES
- SM/ADVISOR CONTACTED (INCLUDE NAME): GEORGE
- DPSM CONTACTED (CELL PHONE OR VM): VM
- RETAILER APPOINTMENT DATE/TIME....: X
- TRADE/REPURCHASE REQUEST.....: X
- EMAIL TO CR/MEDIATION BOX.....: X
- NCDS BROCHURE SENT.....: X
- GOODWILL ASSISTANCE REQUEST.....: X
- ORIGINAL OWNER.....: YES
- MAINTENANCE RECORDS AVAILABLE.....: YES
- MULTIPLE/REPEAT MITSU OWNER.....: NO
- RENTAL REQUEST.....: X
- PARTS ORDERING DELAY.....: X
- REIMBURSEMENT REQUEST.....: NO
- SALES/FINANCE RELATED ISSUES.....: X
- RETAILER COMPLAINT.....: X
- CALLER IS THE VEHICLE OWNER.....: YES
- LETTER REQUEST.....:
- MISCELLANEOUS.....:
- MISCELLANEOUS.....:

-----SHORT NARRATIVE-----
CUST STATES PREVIOUSLY BRAKES WENT OUT AND HAD DAMAGE TO FRONT GRILL
BUT RTLR NEVER FOUND ANY EVIDENCE OF BRAKE FAILURE.
CUST HAS NOT HAD ANY REPAIRS DONE TO FRONT GRILL SINCE OCCURED 03/01.
CUST STATES TOOK IN 2X FOR CONCERNS OF NO BRAKE POWER, PEDAL TO FLOOR.
CUST STATES THE 2ND TIME IT OCCURED WAS ABLE TO BRAKE BUT IT WAS DELAYED.

RETAILER: JEFF
1. PLEASE REVIEW WITH DPSM DAMAGE TO GRILL ON VEHICLE IN RELATION TO
BRAKE BOOSTER RECALL.
2. PLEASE UPDATE FILE WITH INSPECTION AND DPSM DECISION WITH ANY REPAIRS.
THANK YOU, VALERIE

DEALER PRINT, (10/08/01) (VIGV)
***** OUR CUSTOMERS THANK YOU FOR YOUR HELP *****
***** (VALERIE VIGUERIA), (800)464-3535 EXT. (5725) *****
***** CUSTOMER SATISFACTION AND RETENTION IS OUR FIRST PRIORITY *****

&DATE REPAIR COMPLETED OR DECISION RENDERED : 10/09/2001
&REPAIR ORDER NUMBER : [REDACTED]

| CONTINUATION OF FILE NO.: 0295895 |

REASON FOR CONTACT: REOPEN DT: OPEN 20011012 CLOSE 20011018

```

&MILEAGE AT REPAIR      : 31000
&COMMENTS INPUT BY    : JEFF PINAR
&ACTION TAKEN         :
&CUSTOMER STATES BRAKE FAILURE CAUSED DAMAGE TO GRILLE GUARD. KENT WANTED ME
&TO OFFER PARTS ONLY FIRST, CUSTOMER NOTSATISFIED, WILL REPLACE ON 10.18.01 U
&NDER WARRANTY, PARTS AND LABOR.
&*****
&DEALER COMMENTS TRANSMITTED ON (10/09/01), (U06034M )
&FILE CLOSED AS A RESULT OF TRANSMISSION
&*****
10/12/01 LUCA:          **ATT: SERVICE MANAGER**
FILE TO REMAIN OPEN UNTIL CUST APPT ON 10/18/01 TO HAVE VEH
REPAIRS COMPLETED. CLOSE FILE WITH DETAILED NOTES AT THAT TIME. VM TO DPSM
THANK YOU
&*****
FILE WAS REOPENED (10/12/01) (LUCA)
&*****
DEALER PRINT, (10/12/01) (LUCA)
&*****
&***** OUR CUSTOMERS THANK YOU FOR YOUR HELP *****
&***** (ALAN LUCERO ), (800)464-3535 EXT.(5707) *****
&***** CUSTOMER SATISFACTION AND RETENTION IS OUR FIRST PRIORITY *****
&*****
&DATE REPAIR COMPLETED OR DECISION RENDERED : 10/18/2001
&REPAIR ORDER NUMBER : 54575
&MILEAGE AT REPAIR : 32384
&COMMENTS INPUT BY : JEFF
&ACTION TAKEN :
&REPLACE GRILLE GUARD. CUSTOMER WAITED FOR REPAIRS.
&*****
&DEALER COMMENTS TRANSMITTED ON (10/18/01), (U06034M )
&FILE CLOSED AS A RESULT OF TRANSMISSION
&*****

```

MATCHING CUSTOMER SERVICE CONTACT

NAME : [REDACTED] OPEN DATE: 20011008
 ADDRESS : [REDACTED] BURLINGTON NJ [REDACTED] FILE NO: 0295870
 PHONE (W) : [REDACTED] EXT: [REDACTED] PHONE (H) : [REDACTED]
 VIN : JA4HW51RX1J [REDACTED] YEAR/MODEL: 2001 MONTERO
 SERV DLR : 39096 PERUZZI MITSUB
 DELIVERY DATE: 07/10/00 MILEAGE: 40429 CLOSE DATE: 20011008
 GRP/SUB-GRP: SERVICE BRAKES BOOSTER, BRAKE, GENERAL
 COND/REMEDY: GENERAL COMMENTS
 REASON FOR CONTACT: REOPEN DT: OPEN 20011008 CLOSE 20011012
 100801 VIGV

----- CUST STATED THE FOLLOWING ACCIDENT/INCIDENT INFORMATION -----
 DATE OF THE ACCIDENT/INCIDENT: 09/19/01
 ALLEGED DEFECTIVE ITEM: BRAKE ACCUMULATOR
 LOCATION OF INCIDENT: RESIDENTIAL ST
 OTHER VEHICLE (S) INVOLVED: 1 TOW TRUCK
 # OF PEOPLE+DRIVER IN OTHER CAR: 1
 # OF PEOPLE+DRIVER IN CUST CAR: 2
 EXTENT OF INJURIES IF ANY: SORE NECK
 RECEIVED MEDICAL TREATMENT? YES: NO: XX
 NAME (S) OF INJURED PEOPLE: JACOB SMALL
 POLICE NOTIFIED- YES: NO: XX
 REPORT #/CITY OF RECORD:
 HAS CUST CONTACTED INSURANCE- YES: NO: XX
 INSURANCE CARRIER: LIBERTY MUTUAL
 VEHICLE LOCATION: 32046 BRAD BENSON
 IS THE VEHICLE REPAIRED: YES FOR MECHANICAL ONLY
 ESTIMATE/COST OF REPAIR: UNKNOWN FOR BODY DAMAGE
 IS VEHICLE DRIVEABLE: YES
 WHAT IS THE CUST SEEKING FROM MMSA: BODY REPAIRS AND REIMBURSEMENT FOR
 REPAIRS TO TOP PANEL FROM HITTING TOW TRUCK
 DATE FORWARDED TO CSM: 100501

ADVISED THE CUSTOMER THAT HIS/HER CLAIM WILL BE REVIEWED BY THE LEGAL DEPT.,
 AND THAT THE MANUFACTURER'S INSURANCE REPRESENTATIVE WILL BE IN CONTACT
 WITHIN A COUPLE OF WEEKS- YES: XX NO:
 CUST STATES HIT BRAKES AND IT WOULD NOT STOP. CUST STATES THAT PERUZZI
 CONFIRMED ACCUMULATOR BASED ON NOISE AND PROBLEM. CUST STATES HE CHECKED
 BRAKE FLUID WITH INDEP MECHANIC AND THERE WAS NO LEAK. BUT WHEN WENT TO
 32046 HE WAS ADVISED OF A BRAKE LEAK. CUST STATES BRAKE FLUID WAS STILL
 FULL. CUST STATES THERE WERE REPAIRS TO BRAKE ACCUMULATOR AT 32046
 LAST WEEK. CAR DID HAVE DELAY OF REPAIRS FOR PART ORDER.
 VCM ADVISE WILL REQUEST TO HAVE REPAIRS PERFORMED FOR BODY WORK BASED ON
 DPSM INSPECTION. CUST NO LONGER WANTS TO GO TO 32046 BECAUSE OF ORIG
 DIAGNOSIS OF OIL LEAK AND ESC NOT BEING IDENTIFIED.
 CUST STARTED RANTING ABOUT VARIOUS OTHER DEALER COMPLAINTS FROM NO CONTACT
 WHEN PARTS AVAILABLE TO WANTING A REPLACEMENT CAR. VCM RESPECTIVELY ADVISED
 THAT EACH RTLR INDEPENDENTLY OWNED AND OPERATED AND TRAINING ISSUES CAN BE
 ADDRESSD TO GM, CUST WANTS TO GO HIGHER, VCM ADVISE OF BBB OR AG. IN ADDITION
 VEHICLE DOES NOT QUALIFY FOR LLAW, TOO MANY MILES NO REPEAT REPAIR ISSUES
 CUST DISCONNECTED CALL.
 VCM FRWD FILE TO LUCA FOR FURTHER DIRECTION FOR FPPIR OR TO REPER CUST TO
 INSURANCE AGENT.

 10/08/01 VIGV:FILE CLOSED

CONTINUATION OF FILE NO.: 0295870

REASON FOR CONTACT: REOPEN DT: OPEN 20011008 CLOSE 20011012

*(10/08/01) (LUCA) ACCIDENT FILE REVIEW
*
*

*RECEIVED EMAIL FROM VCM VIVG REQUESTING ACCIDENT FILE REVIEW. NO INJURIES. *
*THE CUSTOMER HAS BEEN ADVISED TO REFER CLAIM TO THEIR INSURANCE COMPANY FOR *
FURTHER HANDLING, NO FURTHER ACTION REQUIRED AT THIS JUNCTURE, FILE CLOSED.

FILE WAS REOPENED (10/08/01) (VIGV)

RETAILER: JOHN
1. PLEASE REVIEW DPSM INTINERAY FOR FIELD INSPECTION OF BODY DAMAGE
RELATED TO ACCIDENT ALLEGEDLY CAUSED BY FAILED BRAKE BOOSTER.
2. PLEASE PDATE FILE WITH DATE OF INSPECTION, RECOMMENDATIONS AND DPSM
INVOLVEMENT.
THANK YOU, VALERIE

DEALER PRINT, (10/08/01) (VIGV)

***** OUR CUSTOMERS THANK YOU FOR YOUR HELP *****
***** (VALERIE VIGUERIA), (800)464-3535 EXT. (5725) *****
***** CUSTOMER SATISFACTION AND RETENTION IS OUR FIRST PRIORITY *****

10-8-01 PRAS: FOLLOWED UP WITH S/M JOHN @ 39096 AND REQUESTED THAT CUSTOMER B
E CONTACTED TO HAVE HIS VEHICLE INSPECTED BY DPSM ON 10/12/01 AT THE DEALER.

10-10-01 PRAS: CALLED CUSTOMERS WORK # WHICH WAS DISCONNECTED. PRAS CALLED
CUSTOMERS HOME # WHICH JUST RANG-NO ANSWER, NO ANSWERING NACHINE. PRAS THEN
V/MAILED VCM VIGV ACCORDINGLY AND REQUESTED SHE ATTEMPT TO CONTACT CUSTOMER.

10-11-01 PRAS: FOLLOWED UP WITH DEALER S/M JOHN WHO ADVISED HE WAS ABLE TO
CONTACT CUSTOMER AND HAS SET UP AN APPOINTMENT FOR 10-12-01 AS OUTLINED.

&DATE REPAIR COMPLETED OR DECISION RENDERED : 10/12/2001

&REPAIR ORDER NUMBER :
&MILEAGE AT REPAIR : 99999
&COMMENTS INPUT BY : SATISH V. PRABHU
&ACTION TAKEN :

&DPSM IS AT THE DEALER THIS DATE AND CUSTOMER HAS NOT SHOWN UP FOR THE APPT.
&PRAS CALLED CUSTOMERS HOME # OF [REDACTED] AND LEFT A MESSAGE ADVISING
&THAT DPSM WILL NEED TO INSPECT CUSTOMERS VEHICLE AND MEET WITH CUSTOMER TO
&ADDRESS HIS CONCERNS. DPSM ALSO LEFT A MESSAGE ADVISING THAT THERE ARE 3 REC
&ALLS OUTSTANDING ON HIS VEHICLE. DPSM RECOMMENDED CUSTOMER MAKE AN APPOINTME
&NT TO HAVE HIS VEHICLE SERVICED AND ADVISED DPSM WOULD AUTHORIZE A RENTAL
&VEHICLE AT THAT TIME. DPSM REQUESTED CUSTOMER STAY IN CONTACT WITH SVC MGR
&JOHN CRONIN @ 39096 TO MAKE APPT FOR DPSM INSPECTION IN THE NEAR FUTURE.
&DPSM CLSOING FILE AS CUSTOMER FAILED TO SHOW UP FOR HIS APPOINTMENT.
&*****

| CONTINUATION OF FILE NO.: 0295870 |

REASON FOR CONTACT: REOPEN DT: OPEN 20011008 CLOSE 20011012

&DEALER COMMENTS TRANSMITTED ON (10/12/01), (U39096A)
&FILE CLOSED AS A RESULT OF TRANSMISSION
&*****

MATCHING CUSTOMER SERVICE CONTACT

NAME : ██████████ PEN DATE: 20050117
ADDRESS : ██████████ FORT LAUDERDALE FL ██████████ FILE NO: 0366392
PHONE (W) : ██████████ EXT: ██████████ PHONE (H) : ██████████
VIN : JA4MW51R92J YEAR/MODEL: 2002 MONTERO
SERV DLR : 10273 BILL SEIDLE MIT
DELIVERY DATE: 08/26/02 MILEAGE: 42000 CLOSE DATE: 20050127
GRP/SUB-GRP: SERVICE BRAKES BOOSTER, BRAKE, GENERAL
COND/REMEDY: OPERATIONAL CONCERN
REASON FOR CONTACT: REOPEN DT: OPEN CLOSE
***01/17/05 BARL...@2:34PM

SERVICE BRAKES

PREVIOUS FILE(S) :

MECHANICAL ISSUE # 1 :BRAKE BOOSTER () PREVIOUS RPRS
MECHANICAL ISSUE # 2 :OPEN RECALL FUEL LEVELER () PREVIOUS RPRS
MECHANICAL ISSUE # 3 :N/A () PREVIOUS RPRS
ORIGINAL OWNER: (X) YES; () NO, PURCH MM/YY AT --- MILES
POLICY ADJUSTMENT REQUEST ...: () RENTAL; () OUT OF WARR REPAIR ; () OTHER
PARTS DELAY/BACKORDER: () YES ; PART # ; ORDER #
RETAILER SM/ADVISOR CONTACTED: () YES ; NAME :
DPSM CONTACTED: () YES ; NAME :

CUST ██████████ CALLS MMNA CONCERN DUE TO HIS VEH HAVE THE SAME SYMPTOMS AS THE RECALL FOR: BRAKE BOOSTER ACCUMULATOR. CUST FEELS THAT EVEN THOUGH VEH NOT INVOLVED ON THE RECALL REQUEST FROM MMNA INVOLVEMENTS FOR: EVALUATION, CUST STATED HE SCHED. AN APPT TO BRING VEH IN FOR DLR 10273 TO PERFORM OPEN RECALL. VCM MADE IT CLEAR TO CUST THAT NO GUARANTEES AND DLR MIGHT CHARGE FOR INSPECTION. CUST UNDERSTOOD BUT INSIST MMNA INVOLVEMENTS. VCM ADVISED CUST TO PLEASE DEAL DIRECT WITH DLR 10273'S SM FOR FURTHER REVIEW AND DLR'S SM WILL FOLLOW-UP DIRECTLY WITH CUST TO ADVISED OUTCOME. CUST UNDERSTOOD AND ENDED CALL.

DEALER SERVICE MANAGER, PLEASE RESOLVE
1. PLS REVIEW FILE WITH YOUR DPSM TO DETERMINE ACTION TO BE TAKEN.
2. PLS CONTACT CUST IN RESPONSE TO THEIR CALL TO MMNA AND ADVISE OF DECISION RENDERED OR ACTION PLAN AND SET-UP FOLLOW-UP APPT IF APPLICABLE.
3. PLS UPDATE FILE WITH OUTCOME OF REVIEW AND ANY ACTION TAKEN TO ADDRESS CUST'S REQUESTS OR CONCERNS AND CLOSE THE FILE.
THANK YOU

DEALER PRINT, (01/17/05) (15:00) (BARL)
***** THANK YOU FOR YOUR ASSISTANCE IN RESOLVING OUR CUSTOMERS ISSUE. *****
***** IF YOU HAVE ANY QUESTIONS ABOUT THE FILE, CONTACT *****
***** CUSTOMER CONNECTIONS AT 888-908-6672 TO SPEAK WITH A *****
***** VEHICLES CASE MANAGER. *****
***** CUSTOMER SATISFACTION AND RETENTION IS OUR FIRST PRIORITY! *****

&DATE REPAIR COMPLETED OR DECISION RENDERED : 01/20/2005
&REPAIR ORDER NUMBER : ██████████
&MILEAGE AT REPAIR : 40267
&COMMENTS INPUT BY : ANDRE COVAS
&ACTION TAKEN :

| CONTINUATION OF FILE NO.: 0364392 |

REASON FOR CONTACT: REOPEN DT: OPEN CLOSE

&CUST.BROUGHT IN VEH.1/20/05.INSPECTED VEH.AND FOUND BRAKE ACCUMULATOR FAILED
&CUST.UNDERSTOOD THAT VEH.WAS NOT INVOLVED IN BRAKE ACCUMULATOR RECALL STILL F
< MMNA SHOULD COVER REPAIR.GAVE CUST.ESTIMATE ON REPAIR AND CUST.AUTHORIZED
&TO REPLACE ACCUMULATOR STATEING HE WOULD PURSUE IT WITH MMNA.ALSO PREFORMED
&OUTSTANDING RECALL WHILE VEH.WAS HERE.RETURNED VEH.TO CUST.1/20/05.PLEASE CLO
&E FILE.
&*****
&DEALER COMMENTS TRANSMITTED ON (01/27/2005) (10273ACO)
&FILE CLOSED AS A RESULT OF TRANSMISSION
&*****

MATCHING CUSTOMER SERVICE CONTACT

NAME : [REDACTED] OPEN DATE: 20050318
 ADDRESS : [REDACTED] PALMDALE CA [REDACTED] FILE NO: 0367592
 PHONE (W) : [REDACTED] EXT: [REDACTED] PHONE (H) : [REDACTED]
 VIN : JA4MW51R41 [REDACTED] YEAR/MODEL: 2001 MONTERO
 SERV DLR : 05348 LANCASTER-CA
 DELIVERY DATE: 05/22/00 MILEAGE: 87000 CLOSE DATE: 20050318
 GRP/SUB-GRP: SERVICE BRAKES BOOSTER, BRAKE, GENERAL
 COND/REMEDY: NOISE/KNOCK/RATTLE
 REASON FOR CONTACT: REOPEN DT: OPEN CLOSE
 (03/18/05) (09:30) (LEMD):

SERVICE BRAKES

PREVIOUS FILE(S) :
 MECHANICAL ISSUE # 1 : BRAKE BOOSTER ACCUMULATOR () PREVIOUS RPRS
 MECHANICAL ISSUE # 2 : () PREVIOUS RPRS
 MECHANICAL ISSUE # 3 : () PREVIOUS RPRS
 ORIGINAL OWNER () YES; (X) NO, PURCH MM/YY AT -- --- MILES
 POLICY ADJUSTMENT REQUEST ... () RENTAL; (X) OUT OF WARR REPAIR ; () OTHER
 PARTS DELAY/BACKORDER () YES ; PART # ; ORDER #
 RETAILER SM/ADVISOR CONTACTED: (X) YES ; NAME : JOE
 DPSM CONTACTED (X) YES ; NAME :

SERVICE DCOA

REASON: () UNRESOLVED CONCERN/REPEAT VISITS. VEH AT DEALER () YES; (X) NO
 (X) NEW MECHANICAL ISSUE; MULTIPLE VEHICLE CONCERNS.
 () DEALER UNABLE TO DUPLICATE; SYMPTOM:
 () DEALER DECLINING WARRANTY REPAIRS; REASON:
 (X) DLR NAME/NUMBER (05348 LANCASTER) ; SM/SA NAME (NOT GIVEN)
 () REQUESTED THAT CUST CALL DLR FOR APPT.; () CUST REQUESTING DLR CONTACT
 WHAT IS CUSTOMER REQUESTING FROM MMNA? WANTS MMNA TO FIX

DEALER SERVICE MANAGER, PLEASE RESOLVE

1. PLS REVIEW WITH YOUR GM, TECH-LINE AND YOUR DPSM IF NEEDED TO DETERMINE ACTION TO BE TAKEN.
2. PLS CALL CUST WITH ACTION PLAN AND SET-UP APPT IF NOT ALREADY SCHEDULED.
3. PLS UPDATE FILE WITH FINDINGS AND ANY ACTION TAKEN AND CLOSE THE FILE.

CUST STATED THAT HE TOOK VEH TO DLR# 05348 A COUPLE OF WEEKS AGO DUE TO HE WAS HEARING NOISE IN BRAKE AREA. CUST HAD TAKEN VEH TO INDEPT SHOP FIRST AND ASKED THEN WHAT WAS THE NOISE. INDEPT ADV'D CUST THAT IT WAS A BALL AND ADV'D CUST THAT WE HAD A RECALL ON THE BRAKE BOOSTER ACCUMULATOR. WHEN CUST WENT TO DLR THEY ADV'D HIM RECALL WAS DONE AND NO FURTHER REVIEW WAS DONE. CUST CALLING BACK TO SEE IF MMNA WILL ASSIST. VCM CALLED DLR TO REVIEW. SPOKE WITH JOE WHO STATED THAT R/O# 545837 ONLY STATES NO OPEN RECALLS NO INSPECTION OF SYSTEM WAS DONE. VCM CALLED DPSM TO REVIEW. DPSM SUGGESTED THAT CUST GET VEH TO DLRSHIP TO INSPECT WHO WILL CONTACT DPSM TO REVIEW. VCM GAVE CUST CASE FILE#, & DLR#. CUST WILL CALL DLR TO SET UP APPT. DPSM STATED NOT BE PRINT FILE AT HIS TIME.

03/18/05 LEMD;FILE CLOSED

MATCHING CUSTOMER SERVICE CONTACT

NAME : ██████████ OPEN DATE: 20050412
 ADDRESS : ██████████ EL DORADO HILLS CA ██████████ FILE NO: 0368939
 PHONE (W) : ██████████ EXT: ██████████ PHONE (H) : ██████████
 VIN : JA4MW51R11 ██████████ YEAR/MODEL: 2001 MONTERO
 SERV DLR : 05375 SACRAMENTO MITS
 DELIVERY DATE: 08/24/00 MILEAGE: 79119 CLOSE DATE: 20050414
 GRP/SUB-GRP: SERVICE BRAKES BOOSTER, BRAKE, GENERAL
 COND/REMEDY: OPERATIONAL CONCERN
 REASON FOR CONTACT: REOPEN DT: OPEN CLOSE
 (04/12/05) (09:04) (JUSW):

***** SERVICE BRAKES *****

PREVIOUS FILE(S) :
 MECHANICAL ISSUE # 1 : BRAKE BOOSTER () PREVIOUS RPRS
 MECHANICAL ISSUE # 2 : () PREVIOUS RPRS
 MECHANICAL ISSUE # 3 : () PREVIOUS RPRS
 ORIGINAL OWNER: (X) YES; () NO, PURCH MM/YY AT -- MILES
 POLICY ADJUSTMENT REQUEST ...: () RENTAL; (X) OUT OF WARR REPAIR; () OTHER
 PARTS DELAY/BACKORDER: () YES; PART # ; ORDER #
 RETAILER SM/ADVISOR CONTACTED: () YES; NAME :
 DPSM CONTACTED: () YES; NAME :

CUSTOMER CALLING STATES BRAKE BOOSTER RECALL WAS DONE IN 10/01. CUSTOMER STATES HE IS HAVING THE SAME PROBLEMS. STATES HE KNOWS OTHER MONTERO OWNERS WHO THE PROBLEM HAD REOCCUR. CUSTOMER BELEIVES MMNA SHOULD ASSITS WITH THE REPAIRS IF THE SAME PROBLEMS. BELEIVES IF THE SAME PROBLEM WAS NOT CORRECTED VCM INFORM CUSTOMER WILL ASK SM TO REVIEW WITH DPSM AND GIVE HIM A CALL BACK

***** DEALER SERVICE MANAGER, PLEASE RESOLVE *****

1. PLS REVIEW WITH YOUR GM AND/OR DPSM, TO DETERMINE ACTION TO BE TAKEN.
2. PLEASE CONTACT CUSTOMER IN RESPONSE TO THEIR CALL TO MMNA AND ADVISE OF DECISION OR ACTION PLAN AND SET-UP APPOINTMENT IF APPLICABLE.
3. PLS UPDATE FILE WITH FINDINGS AND ANY ACTION TAKEN AND CLOSE THE FILE.

THANK YOU

DEALER PRINT, (04/12/05) (09:07) (JUSW)
 ***** THANK YOU FOR YOUR ASSISTANCE IN RESOLVING OUR CUSTOMERS ISSUE. *****
 ***** IF YOU HAVE ANY QUESTIONS ABOUT THE FILE, CONTACT *****
 ***** CUSTOMER CONNECTIONS AT 888-908-6672 TO SPEAK WITH A *****
 ***** VEHICLES CASE MANAGER. *****

***** CUSTOMER SATISFACTION AND RETENTION IS OUR FIRST PRIORITY! *****

(04/13/05) (14:59) (ATIM): CUST STATES HE HAS NEVER BROUGHT THE VEHICLE TO 05375 RECENTLY FOR BRAKE CONCERN, WAITING FOR SM TO CONTACT HIM FOR APPT. IN THE MEANTIME, CUST STATES THAT HE CONTACTED NHTSA AND WAS ADVISED THAT HE WILL NEED TO TAKE THE VEHICLE TO DEALER FOR INSPECTION. CUST STATES HE IS GOING OUT OF TOWN TOMORROW AND WANTED TO TAKE CARE OF THIS TODAY, VCM ADVISED CUST TO ALLOW SM TO CONTACT HIM OR TO GO AHEAD AND CALL DEALER FOR APPT TO INSPECT.
 VCM ADVISED CUST THAT FILE HAS BEEN SENT TO SM FOR REVIEW WITH DPSM AS NEEDED

CONTINUATION OF FILE NO.: 0368939

REASON FOR CONTACT: REOPEN DT: OPEN CLOSE

4/13/05 MCMT: SPOKE TO SM HANK. VEHICLE AT DEALERSHIP AT THIS TIME. DIAGNOSIS HAS NOT STARTED. CUSTOMER ASKING FOR MMNA ANSWER NOW. DPSM ADVISED SM THAT RECALL WAS PERFORMED ON 10/23/01 AT 20,807 MILES AND THAT SATISFIES RECALL REQUIREMENT. DPSM ADVISED SM THAT CUSTOMER APPROACH TO THE REQUEST FOR OUT OF WARRANTY GOODWILL ASSISTANCE LEADS ONE TO BELIEVE GRANTING THAT ASSISTANCE WOULD NOT PROMOTE CUSTOMER SATISFACTION, THEREFORE REQUESTS IS DECLINED.

04/14/05 GREN:FILE CLOSED

(04/26/05) (12:27) (LUNM):CUST STATED THAT HE HAD TO PAY 650.00 FOR REPAIR AND RENTAL BECAUSE DPSM MCMT DENIED COVERAGE FOR REPAIR UNDER RECALL THAT HAD BEEN COMPLETED ALREADY. CUST STATED PART IS DEFECTIVE AND IT SHOULD BE COVERED UNDER RECALL BECAUSE IT IS A SAFETY ISSUE. CUST STRONGLY DISAGREES WITH DPSM'S DECISION AND WANTS SITUATION REVIEWED FURTHER. CUST REQUESTED TO SPEAK WITH DPSM OR MANAGER AND ASKED FOR MMNA'S ADDRESS. CUST IS WRITING A LETTER. CUST ALSO STATED THAT HE IS FILING A COMPLAINT WITH DEPARTMENT OF TRANSPORTATION HIGHWAY ADMINISTRATION.

***** APPEALING DPSM DECISION *****

CUST CALLING TO APPEAL DPSM'S DECISION. CUSTOMER DEMANDING ADDITIONAL REVIEW AND ASSISTANCE. ACTION TAKEN:

- (X) REQUEST DPSM CALLBACK CUSTOMER TO DISCUSS DECISION PER DCOA PROCESS.
- (X) OUTBOUND CALL PLACED TO DPSM ****'S (X) CELLPHONE; () OFFICE EXT.
- () DPSM HAS ALREADY DISCUSSED WITH CUST. VCM REVIEWED WITH SUPERVISOR FOR AUTHORIZATION TO CONTACT RPSM FOR REVIEW OF DECISION.
- () RPSM REVIEWED AND CONCURS WITH DPSM'S DECISION. VCM TRANSFERRED CUST TO SUPERVISOR'S QUEUE. TRANSFERRED TO SUPERVISOR ---- FOR HANDLING.
- () CUST CLAIMS TO HAVE NEW/ADDITIONAL INFORMATION. VCM CALLED DPSM TO ADVISE AND REQUEST REVISIT, OR, OFFER DECISION BASED ON NEW INFORMATION.
- () VCM CALLED DPSM TO DISCUSS, OR, REVIEWED WITH SPRVSR FOR AUTHORIZATION TO REVIEW WITH RPSM (IF ALREADY DISCUSSED WITH DPSM).
- () DPSM AGREED TO REVISIT DECISION.

4/26/05 MCMT: NO FURTHER ACTION WILL BE TAKEN REGARDING THIS FILE. DPSM RE VIEWED SITUATION WITH RPSM AND BATB IN WARRANTY DEPT. ALL AGREE THAT MMNA DID SATISFY THE RECALL IN 2001. CUSTOMER DEMANDING APPROACH FROM THE BEGINING LEADS RPSM AND DPSM TO AGREE THAT THERE IS NO GOODWILL TO BE GAINED BY HELP ING THIS CUSTOMER THROUGH OUT OF WARRANTY ASSISTANCE. DPSM WILL NOT CONTACT CUSTOMER.

MATCHING CUSTOMER SERVICE CONTACT

NAME : [REDACTED] OPEN DATE: 20050413
 ADDRESS : [REDACTED] BROOKLYN NY [REDACTED] FILE NO: 0260020
 PHONE (W) : [REDACTED] PHONE (H) : [REDACTED]
 VIN : JA4MW51R02 [REDACTED] YEAR/MODEL: 2002 MONTERO
 SERV DLR : 32040 FREEHOLD MIT
 DELIVERY DATE: 01/28/02 MILEAGE: 65000 CLOSE DATE: 20050413
 GRP/SUB-GRP: SERVICE BRAKES BOOSTER, BRAKE, GENERAL
 COND/REMEDY: OPERATIONAL CONCERN
 REASON FOR CONTACT: REOPEN DT: OPEN CLOSE
 ***04/13/05 BARL...@08:48AM

SERVICE BRAKES

PREVIOUS FILE(S) :
 MECHANICAL ISSUE # 1 : BRAKE ACCUMULATOR BOOSTER CONCERN () PREVIOUS RPRS
 MECHANICAL ISSUE # 2 : N/A () PREVIOUS RPRS
 MECHANICAL ISSUE # 3 : N/A () PREVIOUS RPRS
 ORIGINAL OWNER : () YES; (X) NO, PURCH MM/YY AT 27,000 MILES
 POLICY ADJUSTMENT REQUEST ... : () RENTAL; () OUT OF WARR REPAIR; () OTHER
 PARTS DELAY/BACKORDER : () YES ; PART # ; ORDER #
 RETAILER SM/ADVISOR CONTACTED: () YES ; NAME :
 DPSM CONTACTED : () YES ; NAME :

CUST [REDACTED] CALLS MMNA CONCERN DUE TO VEH WAS TAKEN TO HIS PERSONAL
 MECHANIC REGARDING BRAKE ACCUMULATOR BOOSTER CONCERN AND HIS MECHANIC PULLED
 BULLETIN AND ADVISED THAT HIS VEH HAS A RECALL FOR THIS AND WAS REFERRED TO
 CONTACT MMNA. VCM ADVISED CUST THAT NO RECALL FOR THIS VEH FOR THIS ISSUE
 CONCERN. VCM ADVISED ONLY RECALL HAS BEEN PERFORMED WAS FOR: FUEL LEVELER ON
 11/04/04. CUST AWARE OF THAT. VCM ADVISED THAT HIS VEH DOES NOT QUALIFIED FOR
 THE RECALL DUE TO VEHs AFFECTED ONLY 2001 - 2002 MONTERO MODELS PRODUCED
 BEFORE 06/20/01 AND HIS VEH WAS PRODUCED AFTER ON:10/29/01. CUST INSIST DUE
 TO HIS VEH IS DOING THE SAME SYPTOMS. VCM ADVISED CUST THAT SCHED. AN APPT
 WITH ANY AUTH MITS DLR FOR A DIAGNOSTIC. VCM ADVISED DLRS ARE INDEPENDENTLY
 ONWED/OPERATED AND CHARGE FOR DIAGNOSTIC FEE. VCM MADE IT CLEAR TO CUST NO
 GUARANTEES HOWEVER CAN BE REVIEW. CUST STATED THAT HE WILL DISCUSSED WITH HIS
 INDEPENDENT MECHANIC. VCM ADVISED AGAIN FOR REVIEW NEEDS TO BE DIAGNOSE BY
 ANY AUTH MITS DLR ONLY. CUST UNDERSTOOD AND ENDED CALL.

04/13/05 BARL:FILE CLOSED

MATCHING CUSTOMER SERVICE CONTACT

NAME : ██████████ OPEN DATE: 20050504
 ADDRESS : ██████████ LOS ANGELES CA ██████████ FILE NO: 0270001
 PHONE (W) : ██████████ EXT: ██████████ PHONE (H) : ██████████
 VIN : JA4MW31R611 YEAR/MODEL: 2001 MONTERO
 SERV DLR : 05361 GLENDALE MITS
 DELIVERY DATE: 05/16/01 MILEAGE: 62000 CLOSE DATE: 20050504
 GRP/SUB-GRP: SERVICE BRAKES BOOSTER, BRAKE, GENERAL
 COND/REMEDY: INOPERATIVE
 REASON FOR CONTACT: REOPEN DT: OPEN CLOSE
 ***05/04/05 BARL...@2:56PM

SERVICE BRAKES

PREVIOUS FILE(S) :
 MECHANICAL ISSUE # 1 : BRAKE ACCUMULATOR BOOSTER INOP. (X) PREVIOUS RPRS
 MECHANICAL ISSUE # 2 : N/A () PREVIOUS RPRS
 MECHANICAL ISSUE # 3 : N/A () PREVIOUS RPRS
 ORIGINAL OWNER (X) YES; () NO, PURCH MM/YY AT --- MILES
 POLICY ADJUSTMENT REQUEST () RENTAL; (X) OUT OF WARR REPAIR; () OTHER
 PARTS DELAY/BACKORDER () YES; PART # ; ORDER #
 RETAILER SM/ADVISOR CONTACTED: () YES; NAME :
 DPSM CONTACTED (X) YES; NAME : TALKED TO DPSM BUZG...@3:03PM

CUST ██████████ CALLS AND REQUEST MMNA IMMEDIATE ASSISTANCE AND INVOLVEMENTS
 REGARDING BRAKE ACCUMULATOR BOOSTER CONCERN. CUST STATES VEH CURRENTLY AT DLR
 05361 AND WAS TOLD OOW/AND RECALL PERFORMED ON 12/01 AND WILL BE AT CUST'S
 PAY. CUST FEELS THAT MMNA SHOULD COVER CONCERN DUE TO PROBLEM BACK. VCM
 ADVISED WILL OPEN/FORWARD ABOVE CR FILE TO DLR 05361 SM'S ATTN FOR FURTHER
 REVIEW WITH MMNA AND DLR WILL FOLLOW-UP DIRECTLY WITH CUST TO ADVISED MMNA
 OUTCOME. VCM MADE IT CLEAR TO CUST NO GUARANTEES. CUST INQUIRE ABOUT RENTAL
 VEH. VCM ADVISED MMNA DOES NOT HAVE A RENTAL/LOANER POLICY. CUST UNDERSTOOD.
 (VCM CALLED DPSM BUZG...@3:03PM AND STATED THAT HE WILL REVIEW CONCERN WITH
 DLR'S SM.)

DEALER SERVICE MANAGER, PLEASE RESOLVE

1. PLS REVIEW FILE WITH YOUR DPSM TO DETERMINE ACTION TO BE TAKEN.
2. PLS CONTACT CUST IN RESPONSE TO THEIR CALL TO MMNA AND ADVISE OF DECISION RENDERED OR ACTION PLAN AT CUST'S CELL PH 323 972 1264.
3. PLS UPDATE FILE WITH OUTCOME OF REVIEW AND ANY ACTION TAKEN TO ADDRESS CUST'S REQUESTS OR CONCERNS AND CLOSE THE FILE.

THANK YOU

 DEALER PRINT, (05/04/05) (15:08) (BARL)
 ***** THANK YOU FOR YOUR ASSISTANCE IN RESOLVING OUR CUSTOMERS ISSUE. *****
 ***** IF YOU HAVE ANY QUESTIONS ABOUT THE FILE, CONTACT *****
 ***** CUSTOMER CONNECTIONS AT 888-908-6672 TO SPEAK WITH A *****
 ***** VEHICLES CASE MANAGER. *****

***** CUSTOMER SATISFACTION AND RETENTION IS OUR FIRST PRIORITY! *****
 &DATE REPAIR COMPLETED OR DECISION RENDERED : 05/04/2005
 &REPAIR ORDER NUMBER : ██████████
 &MILEAGE AT REPAIR : 65354
 &COMMENTS INPUT BY : ROSS

| CONTINUATION OF FILE NO.: 0370221 |

REASON FOR CONTACT: REOPEN DT: OPEN CLOSE

&ACTION TAKEN :
&REPLACED BRAKE ACCUMULATOR ONE TIME GOODWILL
&*****
&DEALER COMMENTS TRANSMITTED ON (05/04/2005) (05361JAV)
&FILE CLOSED AS A RESULT OF TRANSMISSION
&*****

MATCHING CUSTOMER SERVICE CONTACT

NAME : [REDACTED] OPEN DATE: 20050705
 ADDRESS : [REDACTED] RANCHO MURIETA CA 95683-925 FILE NO: 0372990
 PHONE (W) : [REDACTED] EXT: [REDACTED] PHONE (H) : [REDACTED]
 VIN : JA4MW51R71L [REDACTED] YEAR/MODEL: 2001 HONTERO
 SERV DLR : 05399 STVNS CRK MITS
 DELIVERY DATE: 09/30/01 MILEAGE: 65287 CLOSE DATE: 20050705
 GRP/SUB-GRP: SERVICE BRAKES BOOSTER, BRAKE, GENERAL
 COND/REMEDY: GENERAL COMMENTS

REASON FOR CONTACT: REOPEN DT: OPEN CLOSE
 070505//KIEG..CUSTOMER WRITES DONR PROTESTING REPLACEMENT OF 2ND HBB ACCUMU-
 LATOR AND PARTS AND LABOR PRICING PRACTICES OF STEVENS CREEK MITS. RECALL
 WAS PERFORMED ON 9/27/01 BY 05352. CUSTOMER ENCLOSED WARRANTY CLAIM FROM
 05352 INDICATING MMNA WAS CHARGED 83.00 TO REPLACE ACCUMULATOR. MORE RECENTLY
 ON 06/20/05, CUSTOMER COMPLAINED OF SQUEEK NOISE WHEN RELEASING BRAKE PEDAL
 AND WAS CHARGED 449.00 BY STEVENS CREEK TO REPLACE ACCUMULATOR. CUSTOMER
 FEELS THE DISCREPENCY IN PRICING BETWEEN RETAILERS IS DEPLORABLE AND
 QUESTIONS WHY IT IS NOT STANDARIZED. CUSTOMER ALSO QUESTIONS WHY HE SHOULD BE
 RESPONSIBLE FOR REPLACEMENT OF PART THAT WAS COVERED UNDER RECALL SEVERAL
 YEARS EARLIER. CUSTOMER REQUESTING WRITTEN RESPONSE TO THE QUESTIONS HE
 RAISES. FORWARDED TO MARLI FOR SCAN AND FAX.WILL FORWARD TO DPSM FOR RESPONSE
 SENT LETTER TO DPSM THIS DATE.

 07/05/05 KIEG:FILE CLOSED

(07/05/05) (15:31) (MJAU): LETTER TO SCAN,

070805///KIEG..SPOKE WITH SMIA WHO STATES HE CONTACTED CUSTOMER WHO EXPRESSED
 DISAPPOINTMENT WITH PRICE DISCREPENCY. DPSM STATES CUSTOMER WAS OVERALL
 PLEASED WITH OWNERSHIP EXPERIENCE AND THOUGHT ENOUGH OF PRODUCT TO PURCHASE
 ANOTHER MITS. DPSM AGREED TO REIMBURSE CUSTOMER HALF OF EXPENSE HE ICURRED
 TO REPLACE HBB ACCUMULATOR. CHECK AMOUNT WILL BE APPROX 215.00. CUSTOMER WAS
 VERY PLEASED WITH DPSM HANDLING OF SITUATION AND MMNA RESPONSE. DPSM WILL
 HAVE RETAILER ISSUE CHECK TO CUSTOMER.

MATCHING CUSTOMER SERVICE CONTACT

NAME : [REDACTED] OPEN DATE: 20051116
ADDRESS : [REDACTED] TULSA OK [REDACTED] FILE NO: 0378774
PHONE (W) : [REDACTED] EXT: [REDACTED] PHONE (H): [REDACTED]
VIN : JA4MW31R71 YEAR/MODEL: 2001 MONTERO
SERV DLR : 37026 DON CARLTON MIT
DELIVERY DATE: 11/19/00 MILEAGE: 66000 CLOSE DATE: 20051129
GRP/SUB-GRP: SERVICE BRAKES BOOSTER, BRAKE, GENERAL
COND/REMEDY: OPERATIONAL CONCERN
REASON FOR CONTACT: REOPEN DT: OPEN 20051130 CLOSE 20051213
(11/16/05) (08:13) (ATIM);

SERVICE BRAKES

PREVIOUS FILE(S) :
MECHANICAL ISSUE # 1 : BRAKE ACCUMULATOR () PREVIOUS RPRS
MECHANICAL ISSUE # 2 : () PREVIOUS RPRS
MECHANICAL ISSUE # 3 : () PREVIOUS RPRS
ORIGINAL OWNER () YES; (X) NO, PURCH 01/05 AT 53,000 MILES
POLICY ADJUSTMENT REQUEST ... () RENTAL; (X) OUT OF WARR REPAIR; () OTHER
PARTS DELAY/BACKORDER () YES; PART # ; ORDER #
RETAILER SM/ADVISOR CONTACTED: () YES; NAME :
DPSM CONTACTED () YES; NAME :

POLICY ADJUSTMENT

CUSTOMER SEEKS POLICY ADJUSTMENT. VCM REVIEWED PROCESS AND FOLLOW-UP TIME.
REASON FOR REQUEST: () FAILURE PREMATURE ; () PREVIOUS RELATED ISSUES
() MULTIPLE VEH PROBLEMS; () LOYAL SERVICE CUSTOMER.
() MULTIPLE MITS OWNER; () PURCHASED FOR RELIABILITY
() VEH ALREADY DIAGNOSED BY MITS DLR; () CUST AGREES TO HAVE DLR DIAGNOSE.
WHAT IS CUSTOMER REQUESTING FROM MMNA?

RETAILER SERVICE MANAGER, PLEASE RESOLVE

- 1. PLS VERIFY CAUSE OF DEFECT OR REASON FOR REQUEST AND REVIEW WITH YOUR GM AND DPSM IF NEEDED, TO DETERMINE IF POLICY ADJUSTMENT IS AVAILABLE.
- 2. PLS ADVISE CUST OF DECISION & ARRANGE FOR FOLLOW-UP REPAIRS IF APPLICABLE.
- 3. PLS UPDATE FILE WITH FINDINGS AND ANY ACTION TAKEN AND CLOSE THE FILE.

CUST STATES VEHICLE WAS INSPECTED AT 37026 LAST WEEK, SM REFERRED CUST TO MMNA REGARDING POSSIBLE POLICY ADJUSTMENT FOR BRAKE ACCUMULATOR. DEALER HAS ADVISED THAT THE RECALL HAD BEEN COMPLETED IN 2001, VEHICLE THEN HAD 10,000 MILES. CUST STATES SAME EXACT ISSUE IS HAPPENING WITH THE BRAKES AS EXPLAINED IN THE RECALL BULLETIN, REQUESTING MMNA REVIEW FOR ASSISTANCE. VCM EXPLAINED THAT FILE WILL BE SENT TO SM FOR REVIEW, UPDATED ALL CONTACT NUMBERS. CUST WILL FOLLOW-UP DIRECTLY WITH SM FOR STATUS.

DEALER PRINT, (11/16/05) (08:19) (ATIM)
***** THANK YOU FOR YOUR ASSISTANCE IN RESOLVING OUR CUSTOMERS ISSUE. *****
***** IF YOU HAVE ANY QUESTIONS ABOUT THE FILE, CONTACT *****
***** CUSTOMER CONNECTIONS AT 888-908-6672 TO SPEAK WITH A *****
***** VEHICLES CASE MANAGER. *****

***** CUSTOMER SATISFACTION AND RETENTION IS OUR FIRST PRIORITY! *****
(11/29/05) (08:52) (MJAU): RECVD CALL FROM CUST STATES WIFE WAS INVOLVED IN AN ACCIDENT, BRAKES DID NOT WORK. STATES VEH WAS PREVIOUSLY DIAGNOSED

CONTINUATION OF FILE NO.: 0378774

REASON FOR CONTACT: REOPEN DT: OPEN 20051130 CLOSE 20051213

BY DON CARLTON WITH FAILED BRAKE ACCUMULATOR. STATES BRAKES WOULD SQUEAK AND
COULD FEEL BRAKE ASSEMBLY JUDDER (CUST DID NOT HAVE DATE OF DIAGNOSIS).
STATES DLR ADVISED BRAKE ACCUMULATOR WAS A RECALLED PART AND SOMETIME AFTER
DIAGNOSIS CONTACTED MMNA FOR REPAIR ASSISTANCE. CUST STATES WAS ADVISED OF
REPAIR APPROVAL (DID NOT HAVE DATE) AND ON THE 23RD RECEIVED A CALL THAT THE
PART WAS IN. THE ACCIDENT OCCURED ON THE 25TH.

----- CUST STATED THE FOLLOWING ACCIDENT/INCIDENT INFORMATION -----

DATE OF THE ACCIDENT/INCIDENT: 11/25/05
ALLEGED DEFECTIVE ITEM: BRAKE ACCUMULATOR
ESTIMATED SPEED OF MITS VEH: BELOW 55 MPH
WERE SEATBELTS WORN ? : DRIVER: YES PASSENGER(S) : YES
WEATHER CONDITIONS: CLEAR - 40'S
LOCATION OF INCIDENT: (WIFE TO CALL WITH INFO)
OTHER VEHICLE(S) INVOLVED: NO
OF PEOPLE+DRIVER IN OTHER CAR: 3
OF PEOPLE+DRIVER IN CUST' CAR: NONE
EXTENT OF INJURIES IF ANY: () YES ; (X) NO :
RECEIVED MEDICAL TREATMENT?: () YES ; (X) NO :
NAME(S) OF INJURED PEOPLE: POLICE NOTIFIED: (X) YES ; () NO ;
REPORT # AND/OR CITY OF RECORD: HWY PATROL (WIFE TO CALL WITH DETAILS)
HAS CUST CONTACTED INSURANCE: (X) YES ;
INSURANCE CARRIER: USAA ; CLAIM #
VEHICLE LOCATION: AT BODY SHOP, NAME KNOWN, PH# 573-302-0229
IS THE VEHICLE REPAIRED: NO
ESTIMATE/COST OF REPAIR: UNKNOWN
IS VEHICLE DRIVEABLE: () YES ; (X) NO
WHAT IS CUST SEEKING FROM MMNA?: JUST WANT A NON-USED LIKE VEH
DATE FORWARDED TO ATIM: 11/29/05
SENT AIRBAG BROCHURE () : REFERRED CUST TO WWW.ACTSINC.ORG ()
ADVISED THE CUSTOMER THAT HIS/HER CLAIM WILL BE REVIEWED BY THE LEGAL DEPT.
AND THAT THE MANUFACTURER'S INSURANCE REPRESENTATIVE WILL BE IN CONTACT
WITHIN A COUPLE OF WEEKS: () YES ; () NO

CUSTOMER'S HUSBAND CALLED, DOES NOT HAVE FULL DETAILS, STATES WILL HAVE
WIFE CALL BACK WITH ADDITIONAL INSURANCE INFO, LOCATION OF VEH, HWY PATROL
REPORT #, EXACT LOCATION OF ACCIDENT.
STATES WAS DRIVING ON A HWY IN MISSOURI, UNDER 55 MPH WHEN THE VEH
INFRONT STOPPED/SLOWED TO MAKE A RIGHT TURN. STATES HIS WIFE ATTEMPTED TO
BRAKE AND VEH DID NOT STOP, STATES WIFE PUMPED BRAKES AND VEH SLOWED A
LITTLE. STATES WIFE HAD TO SWERVE TO THE RIGHT, ONTO THE SHOULDER OF THE
ROAD TO MISS THE VEHICLE. THE VEH STOPPED IN A DITCH. HIS WIFE AND TWO
DAUGHTERS WERE IN THE VEHICLE. NO INJURIES SUSTAINED. CUST ALLEGES FAILURE
DUE TO BRAKE ACCUMULATOR. CUST CONCERNED WITH THE DEPRECIATION OF THE VEH
DUE TO BODY/FRAME DAMAGE. CUST STATES WANTS VEH TOTALLED, ADVISED WOULD BE
UP TO HIS INSURANCE COMPANY, MMNA CANNOT TOTAL HIS VEHICLE.
VCM REFERRED CUST TO INSURANCE COMPANY, ADVISED OF SUBROGATION PROCESS.

CONTINUATION OF FILE NO.: 0378774

REASON FOR CONTACT: REOPEN DT: OPEN 20051130 CLOSE 20051213

EMAIL TO ATIM.

11/29/05 ATIM:FILE CLOSED

(11/29/05) (10:06) (ATIM): VCM REVIEWED FILE, EMAIL TO STEE AND LANR.

(11/29/05) (10:23) (LEMD): CUST WIFE (CATHERINE) WAS CALLING BACK WITH DETAIL S:

CUST WIFE WAS GOING NORTH ON HWY 5 (2 LANE HWY W/NO SHOULDER) WHEN THERE WAS A 2ND VEH STOPPED IN FRONT OF HER TO TURN RIGHT INTO A BUSINESS AND A 3RD VEH SLOWING APPROACHING COMING IN SOUTH DIRECTION TO TURN LEFT INTO SAME BUSINESS DRIVEWAY. CUST THEN STARTED TO DEPRESS HER BRAKES AND FOUND THAT THE BRAKES DID NOT ENGAGE. CUST STATED SHE FELT LIKE SHE SLOWED SOME BUT DID NOT FEEL ANY BREAKING. CUST STATED SHE SAID NO BUT NOTHING WAS HAPPENING.

CUST STATED SHE WENT INTO THE DITCH TO THE RIGHT OF HER DOWNWARD AND CAME BACK UP AND PULLED FORWARD TO GET OUT OF THE WAY. CUST STATED SHE IMPACTED LARGE CONCRETE BLOCKS AT SIDE OF ROAD THAT BENT THE FRAME. THERE WAS NO CITATION ISSUED AND WAS INVESTIGATED BY MISSOURI STATE HWY PATROL INCIDENT# [REDACTED] ON 11-25-05 APPROX 11:40AM

CUST STATED SHE KNOW THAT BRAKE ACCUMULATOR WAS A RECALL AND HAD A APPT ON 11/28/05 TO HAVE RECALL PERFORMED BUT WAS TOLD BY MITSU (NOT SURE WHO) WAS OK TO DRIVE.

CUST DOES NOT WANT HER INSURANCE TO HAVE TO PAY FOR THIS.

CUST IS BORROWING A CAR BUT IF LONG PROCESS WOULD WANT MMNA TO GIVE THEM A CAR TO DRIVE 2004 OR 2005 (NOT USED).

(11/29/05) (11:31) (STEE): REVIEWED FILE WITH K.REEVES: BRAKE ACCUMULATOR FAILURE WILL NOT RESULT IN A LOSS OF BRAKES WHEN THE VEHICLE IS BEING DRIVEN. BASED ON THE INFORMATION IN THE FILE, K.REEVES FEELS THAT THE ABS SYSTEM ENGAGED ALLOWING MRS. [REDACTED] TO STEER WHILE UNDER EMERGENCY BRAKING. IF THERE WAS AN ISSUE WITH THE ABS SYSTEM, THE ABS LIGHT WOULD HAVE ILLUMINATED AND A FAULT CODE MEMORIZED. FWD EMAIL BACK TO ATIM TO HAVE CUSTOMER FOLLOW UP WITH INS. COMPANY AND PALM TO RESPOND TO CUSTOMER'S REQUEST FOR A REPLACEMENT VEHICLE. ONE OPTION IS FOR THE CUSTOMER TO HAVE VEHICLE TAKEN TO A MITS DEALERSHIP TO SEE IF THERE ARE ANY DTCS STORED. DPSM MUST BE ALERTED IF THE CUSTOMER IS INTERESTED IN PURSUING THIS. CUSTOMER WOULD BE RESPONSIBLE FOR ANY DIAGNOSTIC FEES AT THE DEALERSHIP.

11/29/05 (16:56) PALM: RVW'D FILE, EM TO JUSC, CC OLIC REQUESTING THAT JUSC TREAT THIS FILE AS A DEMAND.

OLD REP WAS = ATIM, NEW REP IS = JUSC

FILE WAS REOPENED (11/30/05) (OLIC)

11/30/05 OLIC: PER EMAIL FROM ATIM, C/R. CUST SEEKS BUYBACK DUE TO BRAKE CONCERN ALLEGEDLY CAUSING ACCIDENT, CREATED HARDFILE. FWD'D TO JUSC

(11/30/05) (08:25) (ATIM): VCM CALLED CUST AND LEFT DETAILED MESSAGE, CUST

| CONTINUATION OF FILE NO.: 0378774 |

REASON FOR CONTACT: REOPEN DT: OPEN 20051130 CLOSE 20051213

REFERRED BACK TO INSURANCE CO AND GAVE OPTION TO HAVE MITSU DEALER INSPECT
BRAKE SYSTEM AT CUST/INSURANCE COST.

(11/30/05) (08:43) (LEMD): CUST RETURNED VCM (ATIM) CALL. VCM REFERRED CUST
TO HIS INSURANCE COMPANY OR DEALER FOR DIAGNOSIS AT CUST COST. CUST STATED OK

(11/30/05) (13:10) (JUSC): JUSC RVW'D FILE AND SPOKE W/DPSM (SENJ) WHO WASN'T
AWARE OF CUSTOMER'S VEH DAMAGE AND REPLACEMENT DEMAND. MM ASKED SENJ TO GET
DETAILS ON PARTS ORDERING TO ADVISE WHEN CUST WAS NOTIFIED. SENJ CONFIRMED
ACCUMULATOR RPR WAS AUTHORIZED AS "GOODWILL" SINCE RECALL HAD BEEN COMPLETED
ALREADY AND DUE TO THIS BEING A SAFETY CONCERN. MM ADVS'D OF COMMENTS FROM
TECHNICAL ABOUT OPERATION OF ABS - SENJ SAYS CUST HAS NO PERFORMANCE CONCERNS
OTHER THAN SQUEAK AND JUDDER AND JUSC MENTIONED CUSTOMER'S COMMENTS ABOUT
PUMPING BRAKES, NOT ADVS'D FOR ABS-EQUIPPED VEHICLES. SENJ WILL FOLLOW UP W/
DLR AND ADVISE MM OF FINDINGS. JUSC WILL CONTACT CUST AND REFER TO DLR FOR
INSPECTION/TO RETRIEVE CODES ADVISING THIS IS AT THEIR EXPENSE W/EXCEPTION OF
ACCUMULATOR REPAIRS PREVIOUSLY AUTHORIZED.

(11/30/05) (13:45) (JUSC): MM RCV'D A CALL BACK FROM SENJ WHO SAYS CUST
PURCHASED VEH USED 1/05; HE SAYS THE PARTS WERE ORDERED 11/22, CUST NOTIFIED
11/23 BUT WERE UNABLE TO RETURN TO DLR AND THEN COLLISION OCCURRED 11/25. MM
ADVS'D CUST WILL BE CONTACTED, ADVS'D REPLACEMENT IS NOT AN OPTION WE CAN
CONSIDER AND DETERMINE CONDITION OF VEHICLE. MM WILL UPDATE SENJ AFTER DISCU-
SSION W/CUST FOR NEXT ACTION.

(12/01/05) (16:01) (JUSC): JUSC PLACED A CALL TO CUSTOMER ON CELL AND LEFT
VM ASKING FOR A CALL BACK.

(12/01/05) (16:08) (RUMS):
CUST RETURNING JUSC CALL, VCM ADVISED JUSC IS NOT AVAIL AT THIS TIME HOWEVER
MESSAGE WILL BE GIVEN TO JUSC TO CONTACT CUST AS SOON AS SHE IS AVAIL.
CUST ASKED TO BE CALLED TOMORROW ON WORK# [REDACTED] ...
VCM FWD MESSAGE TO JUSC

(12/02/05) (10:15) (JUSC): JUSC RCV'D CALL BACK FROM MR. DEATON WHO SAYS HIS
INSUR. CO. INSPECTED VEH 12/1 @ BODY SHOP AND THE FRAME IS BENT, VEH CANNOT
BE DRIVEN. MM ADVS'D MY INVOLVEMENT IS IN RESPONSE TO REPLACEMENT DEMAND
AND EXPLAINED VEH DOES NOT QUALIFY FOR REPLACEMENT, WE ARE INTERESTED IN
REVIEWING MATTER TO DETERMINE MMNA'S POSITION. CUST UNDERSTOOD AND SAYS INS.
ADJUSTER IS MARK @ (314) 638-7517 WHO HAS NOT ADVS'D OF FINDINGS YET. CUST
SAYS ABS LIGHT IS ON AND STAYS ON AND HAS RESEARCHED MATTER W/NHTSA AND FEELS
BRAKE FAILURE IS A COMMON PROBLEM. MM REPLIED THAT WILL BE NOTED BUT THAT
MMNA HAS NOT FOUND THIS TO BE COMMON; AT THIS TIME WE WILL REVIEW THE FIND-
INGS W/INS. CO. AND THEY MAY NEED TO AUTHORIZE TRANSPORT & INSPECTION OF ABS
LIGHT CONCERN W/DEALER. MM WILL REVIEW W/DPSM AND FOLLOW UP WITH CUST, MR.
DEATON UNDERSTOOD. **JUSC CALLED MR. DEATON BACK TO CLARIFY IF THE BRAKE
OR ABS LIGHT IS ON - HE REPLIED THE LATTER AND THAT NO INDICATORS WERE ON
UNTIL AFTER THE ACCIDENT.

CONTINUATION OF FILE NO.: 0378774

REASON FOR CONTACT: REOPEN DT: OPEN 20051130 CLOSE 20051213

 (12/02/05) (10:41) (JUSC): MM DISCUSSED THE FINDINGS W/DPSM SENJ AND ASKED THAT HE HAVE DLR FAX OVER R/O FROM INITIAL DIAGNOSIS INCLUDING ANY TECH NOTES AS MM WANTS TO VFY HOW THEY DIAGNOSED PROBLEM; WAS VEH INSPECTED/DRIVEN TO CONFIRM NOISE THEN WARR. CHK'D TO CONFIRM RECALL ALREADY COMPLETED ETC... SENJ WILL FAX, ONCE RCV'D JUSC WILL DISCUSS W/R. LANTZ TO DETERMINE IF MMNA WANTS TO INSPECT VEH BEFORE CONTACTING INS. CO. ***MM RCV'D VM UPDATE FROM SENJ WHO SAYS THERE WAS NO R/O WRITTEN, VERBAL DISCUSSION ONLY ABOUT BRAKE NOISE AND INSPECTION. JUSC HAS LEFT VM AND SENT E-MAIL TO R. LANTZ FOR RVW.

(12/05/05) (10:31) (JUSC): MM RCV'D REPLY FROM SERVICE ENGINEERING, R. LANTZ ADVS'D THEIR GROUP DOES NOT NEED TO REVIEW THIS MATTER ANY FURTHER. VM LEFT FOR INSURANCE ADJUSTER, MARK ASKING FOR A CALL BACK. MM CALLED SENJ AND PROVIDED AN UPDATE, MM WILL ADVISE INS. CO. TO INSPECT VEH AND SUBROGATE IF NEEDED.

(12/06/05) (07:24) (JUSC): JUSC RCV'D VM BACK FROM MARC W/USAA WHO RFR'D MM TO ADJUSTER AT (800) 531-8222. POLICY # [REDACTED] FOR MORE INFORMATION. MM SPK W/CHRISTINE LOPEZ WHO SAYS VEH IS REPAIRABLE, ESTIMATE AS OF 12/2 BEFORE CUST'S DEDUCTIBLE IS \$4,701.00 & THE DAMAGE IS TO THE RIGHT FRONT END. MM ASKED IF THEY WLD INSPECT VEH FOR POSSIBLE PL CONCERN, CHRISTINE REPLIED NO. IT WLD BE UP TO THE CUST TO HAVE INSPECTED ONCE VEH IS RPR'D. MR. DEATON CAN HAVE VEH INSPECTED @ DLR OR BRAKE SHOP ETC... MM REPLIED CUST WLD BE ADV'SD OF MMNA'S POSITION, HE CAN HAVE VEH RPR'D & INSPECTION FOR ABS/BRAKES WLD BE AT HIS EXPENSE; MMNA CAN REVIEW THE FINDINGS @ THAT TIME. CHRISTINE UNDERSTOOD & WILL UPDATE HIS CUST'S FILE. JUSC ADVS'D DPSM OF DISCUSSION W/INS.CO. AND CUST WILL BE ADVS'D TO GET VEH RPR'D AND ABS/BRAKE CONCERNS INSPECTED @ HIS EXPENSE ONCE RPR'D.

(12/06/05) (08:07) (JUSC): MM SPK W/CUST AND EXPLAINED MMNA WILL NOT OFFER ANY ASSISTANCE TO RPR VEH FOR PHYSICAL DAMAGE, SO HE WLD NEED TO AUTHORIZE BODY REPAIRS; ONCE VEH IS RPR'D HE CAN REVIEW FINDINGS W/MMNA IF NEEDED. CUST REPLIED HE'S NOT HAPPY W/THIS REPLY FROM MMNA AND MENTIONED HIS WIFE AND 2 DAUGHTERS WERE INJURED IN COLLISION, ADDING THAT HIS WIFE WILL NEED PHYS. THERAPY. MM REPLIED THAT WILL BE ADDED TO NOTES AS NO INJURY WAS MENTIONED BEFORE, ALSO REMINDED CUST THAT VEH IS NO LONGER UNDER WARRANTY & THERE ARE NO EXISTING RECALLS - COLLISION DAMAGE WLDN'T HAVE BEEN COVERED ANYWAY. MR. DEATON SAYS HE WILL RE-CONTACT INS. CO. TO ADVISE HE WANTS TO PURSUE. CUST IS CONCERNED W/FRADE DAMAGE AND RESALE VALUE, MM REPLIED THAT WLD BE @ THE DISCRETION OF INS. CO. CUST UNDERSTANDS MMNA POSITION; MM ADVS'D M. BLUME OF CUST CONCERN SINCE CUST HAS NOW MENTIONED INJURIES; M. BLUME REPLIED WE CAN DOCUMENT AND WAIT FOR POSSIBLE FUTURE CONTACT FROM INS. CO. OR OTHER PARTY.

(12/13/05) (08:51) (JUSC): MM FOLLOWED UP WITH S/M, ROB SCOTT WHO CONFIRMED VEH HAS NOT BEEN BACK, NOR HAVE THEY HEARD FROM CUST. JUSC EXPLAINED MMNA HAS DECLINED THE CUST'S ROST FOR REPAIR OR REPLACEMENT, AND HAVE RFR'D THE MATTER TO THE INS. CO. FOR HANDLING. S/M UNDERSTOOD AND WILL NOTIFY DPSM IF ANYTHING SHLD CHANGE OR IF VEH COMES IN FOR INSPECTION. JUSC ALSO E-MAILED

| CONTINUATION OF FILE NO.: 0378774 |

REASON FOR CONTACT: REOPEN DT: OPEN 20051130 CLOSE 20051213

DPSM (SENJ) ADVISING FILE IS BEING CLOSED UNTIL FURTHER CONTACT.

 12/13/05 JUSC:FILE CLOSED

 (12/22/05) (10:54) (JUSC): MM RCV'D VOICEMAIL FROM CUST STATING HE WANTS TO
 HAVE VEH REPAIRED BUT WANTS ACCUMULATOR TO BE INSTALLED IN COLUMBIA, MO
 INSTEAD, CUST RQST'D CALL BACK. MM LEFT MSG FOR DPSM (SENJ) ADVISING AND
 THAT MM FEELS REPAIRS SHOULD TAKE PLACE AT 37026 INSTEAD OF INVOLVING A NEW
 DLR, MM ASKED FOR A CALL TO DISCUSS.

 (12/22/05) (13:56) (JUSC): MM RETURNED CUST'S CALL AND ADVS'D GOODWILL AUTH.
 IS AT DON CARLTON, DPSM AND MM AGREE REPAIRS SHOULD TAKE PLACE THERE. MR.
 DEATON SAYS HE'S NOT SURE HE WILL DRIVE AND MAY CONSIDER TRANSPORTING VEH
 THERE AFTER BODY SHOP REPAIRS. NOTHING FURTHER IS NEEDED.

 (01/09/06) (13:26) (JUSC):RCV'D CALL FROM AUDREY @ USAA ASKING FOR MMNA'S
 POSITION TOWARDS COLLISION DAMAGE. MM ADVS'D SAME AS NOTED 12/6/05, OFFER TO
 HAVE RECALL COMPLETED A 2ND TIME AS "GOODWILL" STILL OPEN @ DLR 37026. INSUR.
 REP REQUIRES NOTHING ELSE.

MATCHING CUSTOMER SERVICE CONTACT

NAME : ██████████ OPEN DATE: 20060227
 ADDRESS : ██████████ WOODSTOCK GA ██████████ FILE NO: 0381777
 PHONE (W) : ██████████ EXT: ██████████ PHONE (H) : ██████████
 VIN : JA4MW51R81 ██████████ YEAR/MODEL: 2001 MONTERO
 SERV DLR : 11119 CRMX MIT-TWNCIR
 DELIVERY DATE: 05/20/00 MILEAGE: 38193 CLOSE DATE: 20060227
 GRP/SUB-GRP: SERVICE BRAKES BOOSTER, BRAKE, GENERAL
 COND/REMEDY: GENERAL COMMENTS
 REASON FOR CONTACT: REOPEN DT: OPEN CLOSE
 ***02/27/06 BARL @1:44PM

SERVICE BRAKES

PREVIOUS FILE(S) :
 MECHANICAL ISSUE # 1 :SEEK REIMB. \$309.29 () PREVIOUS RPRS
 MECHANICAL ISSUE # 2 :N/A () PREVIOUS RPRS
 MECHANICAL ISSUE # 3 :N/A () PREVIOUS RPRS
 ORIGINAL OWNER: (X) YES; () NO, PURCH MM/YY AT -- --- MILES
 POLICY ADJUSTMENT REQUEST ...: () RENTAL; () OUT OF WARR REPAIR ; () OTHER
 PARTS DELAY/BACKORDER: () YES ; PART # ; ORDER #
 RETAILER SM/ADVISOR CONTACTED: () YES ; NAME :
 DPSM CONTACTED: () YES ; NAME :

██████████ CALLS MMNA SEEK REIMBURSEMENT FOR: \$309.29. CUST STATED VEH WAS
 MAKING A NOISE 9 DAYS AGO AND TOOK VEH TO CARMAX SERVICE FACILITY ON 02/24/06
 WAS ADVISED IS THE BRAKE ACCUMULATOR. CARMAX FACILITY REPAIRED VEH AND REFER-
 RED CUST TO CONTACT MMNA DUE TO RECALL. VCM APPRECIATED CUST TOOK THE TIME
 TO CALL AND ADVISED RECALL WAS PERFORMED ON 11/24/01 FOR:C0109W BRAKE
 ACCUMULATOR INSPECTION/PART REPLACEMENT. VCM ADVISED PART WARR WHICHEVER
 COMES FIRST 12/12 VEH OOW AND PARTS TOO. VCM ADVISED NO PARTICIPATION FROM
 MMNA. CUST UNDERSTOOD AND ENDED CALL.
 (NO FURTHER ACTION REQUIRED, FILE CLOSED.)

02/27/06 BARL;FILE CLOSED

MATCHING CUSTOMER SERVICE CONTACT

NAME : ██████████ OPEN DATE: 20060428
ADDRESS : ██████████ CANTON MI ██████████ FILE NO: 0383649
PHONE (W) : ██████████ PHONE (H) :
VIN : JA4MW51R91 YEAR/MODEL: 2001 MONTERO
SERV DLR : 23008 MORAN MIT
DELIVERY DATE: 06/02/00 MILEAGE: 100000 CLOSE DATE: 20060512
GRP/SUB-GRP: SERVICE BRAKES BOOSTER, BRAKE, GENERAL
COND/REMEDY: NOISE/KNOCK/RATTLE
REASON FOR CONTACT: REOPEN DT: OPEN CLOSE
(04/28/06) (11:46) (BARL);

SERVICE BRAKES

PREVIOUS FILE(S) :
MECHANICAL ISSUE # 1 :DRIVER SIDE MAKING NOISE(BRAKE ACCUMULATOR) (X) PR RPRS
MECHANICAL ISSUE # 2 :N/A () PREVIOUS RPRS
MECHANICAL ISSUE # 3 :N/A () PREVIOUS RPRS
ORIGINAL OWNER: (X) YES; () NO, PURCH MM/YY AT --- MILES
POLICY ADJUSTMENT REQUEST ...: () RENTAL; (X) OUT OF WARR REPAIR ; () OTHER
PARTS DELAY/BACKORDER: () YES ; PART # ; ORDER #
RETAILER SM/ADVISOR CONTACTED: () YES ; NAME :
DPSM CONTACTED: (X) YES ; NAME :LFT VM TO DPSM SINM...@12:10PM

CUST ██████████ CALLS MMNA COMPLAINT ABOUT DRIVER SIDE MAKING NOISE WHEN BRAKING. CUST STATES IS THE BRAKE ACCUMULATOR AND CUST SCHED. AN APPT WITH DLR 23008 ON 05/01/06 @07:30AM AND REQUEST MMNA IMMEDIATE ASSISTANCE CLAIMS RECALL (BRAKE ACCUMULATOR) WAS NOT PERFORMED PROPERLY. VCM APOLOGIZED FOR CONCERN HOWEVER ADVISED RECALL WAS PERFORMED ON 10/08/01 AND ADVISED PART WAS REPLACED (ACCUMULATOR, BRAKE BOOSTER) AND (BRAKE FLUID). VCM ADVISED MMNA ALREADY COMPLIED WITH RECALL OBLIGATION. CUST INSIST PART DEFECT. VCM ADVISED PART WARR ONLY 12/12 AND OOW. CUST STATED THAT NO MATTER WHAT PART PROBLEM AND REQUEST MMNA ASSISTANCE. VCM ADVISED WILL OPEN/FORWARD ABOVE FILE TO DLR 23008 SM'S ATTN FOR FURTHER REVIEW WITH MMNA AND DLR WILL FOLLOW-UP DIRECTLY WITH CUST TO ADVISE MMNA OUTCOME. VCM MADE IT CLEAR TO CUST NO GUARANTEES. AND ADVISED DLR 23008 MIGHT CHARGE CUST FOR DIAGNOSTIC FEE.
(VCM LFT VM TO DPSM SINM...@12:10PM)
(VCM CALLED DLR 23008 @12:13PM LFT VM TO SM MIKE DOOLEY.)

DEALER SERVICE MANAGER, PLEASE RESOLVE

- 1. PLS REVIEW FILE WITH YOUR DPSM TO DETERMINE ACTION TO BE TAKEN.
- 2. PLS CONTACT CUST IN RESPONSE TO THEIR CALL TO MMNA AND ADVISE OF DECISION RENDERED OR ACTION PLAN AT CUST'S CELL PH 586 899 1891.
- 3. PLS UPDATE FILE WITH OUTCOME OF REVIEW AND ANY ACTION TAKEN TO ADDRESS CUST'S REQUESTS OR CONCERNS AND CLOSE THE FILE.

THANK YOU

DEALER PRINT, (04/28/06) (12:14) (BARL)
***** THANK YOU FOR YOUR ASSISTANCE IN RESOLVING OUR CUSTOMERS ISSUE. *****
***** IF YOU HAVE ANY QUESTIONS ABOUT THE FILE, CONTACT *****
***** CUSTOMER CONNECTIONS AT 888-908-6672 TO SPEAK WITH A *****
***** VEHICLES CASE MANAGER. *****
***** CUSTOMER SATISFACTION AND RETENTION IS OUR FIRST PRIORITY! *****

CONTINUATION OF FILE NO.: 0383649

REASON FOR CONTACT: REOPEN DT: OPEN CLOSE

 &DATE CUSTOMER CONTACTED : 05/01/2006 DATE COMMENTS ENTERED: 05/03/2006
 &CONTACTED BY : MIKE DOOLEY
 &CUSTOMER APPOINTMENT DATE :
 &DPSM INSPECTION PENDING : NO DATE:
 &BACK ORDERED PART # (S) :
 &PARTS ORDER D-S-SHO # (S) :
 &TECHLINE ASSISTANCE PENDING : NO IF YES, RESOLUTION IN SUMMARY
 &SUMMARY OF CONTACT :
 &CUSTOMER HAD APPT. FOR 5/1/06 SHOWED UP AT DEALER AT 6:05PM NO TECHNICIANS
 &AT DEALERSHIP AT THAT TIME CUSTOMER TO COME BACK BY 5/6/2006

 &DEALER COMMENTS TRANSMITTED ON (05/03/2006) (MSINKOFF)
 &FILE UPDATED AS A RESULT OF TRANSMISSION

 &DATE REPAIR COMPLETED OR DECISION RENDERED : 05/12/2006
 &REPAIR ORDER NUMBER :
 &MILEAGE AT REPAIR : 100000
 &COMMENTS INPUT BY : MIKE DOOLEY
 &ACTION TAKEN :
 &CUSTOMER STOPPED IN AFTER 5:30PM NO TECHNICIANS AVAILABLE. SM ADVISED CUSTOM
 &R THAT BASED ON TIME AND MILEAGE OF VEHICLE NO REPAIR WOULD BE COVERED UNDER
 &WARRANTY. ADVISED CUSTOMER REVIEWED WITH MMNA EVEN IF ACCUMULATOR WAS
 &BAD HAS BEEN OVER 80,000 MILES SINCE REPLACED IN 2001 AND 5 YRS.

 &DEALER COMMENTS TRANSMITTED ON (05/12/2006) (MSINKOFF)
 &FILE CLOSED AS A RESULT OF TRANSMISSION

MATCHING CUSTOMER SERVICE CONTACT

NAME : ██████████ OPEN DATE: 20060502
 ADDRESS : ██████████ LAS CRUCES NM ██████████ FILE NO: 0383731
 PHONE (W) : ██████████ EXT: ██████████ PHONE (H) : ██████████
 VIN : JA4MW31R61 ██████████ YEAR/MODEL: 2001 MONTERO
 SERV DLR : 33023 SISBARRO MITS.
 DELIVERY DATE: 05/31/00 MILEAGE: 103000 CLOSE DATE: 20060505
 GRP/SUB-GRP: SERVICE BRAKES BOOSTER, BRAKE, GENERAL
 COND/REMEDY: INOPERATIVE
 REASON FOR CONTACT: REOPEN DT: OPEN CLOSE
 (05/02/06) (11:03) (BARL);

SERVICE BRAKES

 PREVIOUS FILE(S) :

MECHANICAL ISSUE # 1 :BRAKE NOISE FROM DRIVER SIDE (ACCUMULATOR) (X) PRVIUS RPRS
 MECHANICAL ISSUE # 2 :N/A () PREVIOUS RPRS
 MECHANICAL ISSUE # 3 :N/A () PREVIOUS RPRS
 ORIGINAL OWNER : () YES; (X) NO, PURCH MM/05 AT 79,000 MILES
 POLICY ADJUSTMENT REQUEST ... : () RENTAL; (X) OUT OF WARR REPAIR ; () OTHER
 PARTS DELAY/BACKORDER : () YES ; PART # : ORDER #
 RETAILER SM/ADVISOR CONTACTED: (X) YES ; NAME :LFT VM TO SM @11:20AM
 DPSM CONTACTED : (X) YES ; NAME :LFT VM TO DPSM PETB...@11:23AM

CUST MR ██████████ CALLS MMNA ADVISED NOISE FROM DRIVER SIDE UNDER THE DASH. CUST
 TOOK VEH TO DLR 33023 TODAY (05/02) WAS ADVISED NEED BRAKE ACCUMULATOR. CUST
 STATED DLR 33023 ADVISED RECALL HAS BEEN PERFORMED ON 12/01 AND CUST'S
 RESPONSIBILITY. CUST STATED THAT HE IS HAVING THE SAME SYMPTOMS ACCORDING TO
 WHAT STATES ON THE RECALL AND REQUEST/INSIST MMNA ASSISTANCE DUE TO FEELS
 THAT PART REPLACED WHEN RECALL WAS PERFORMED DEFECTIVE. CUST CURRENTLY HAS
 POSSESSION OF THE VEH DUE TO DECLINED TO PAY FOR REPAIRS. VCM APOLOGIZED FOR
 CONCERN AND ADVISED WILL OPEN/FORWARD ABOVE FILE TO DLR 33023 SM'S ATTN FOR
 FURTHER REVIEW WITH MMNA AND DLR 33023 WILL FOLLOW-UP DIRECTLY WITH CUST BY
 THE END OF THIS WEEK TO ADVISED MMNA OUTCOME. VCM MADE IT CLEAR TO CUST NO
 GUARANTEES. CUST UNDERSTOOD.
 (VCM LFT VM TO SM @11:20AM - LFT VM TO DPSM PETB...@11:23AM.)

DEALER SERVICE MANAGER, PLEASE RESOLVE

1. PLS REVIEW FILE WITH YOUR DPSM TO DETERMINE ACTION TO BE TAKEN.
2. PLS CONTACT CUST IN RESPONSE TO THEIR CALL TO MMNA AND ADVISE OF
DECISION RENDERED OR ACTION PLAN AND SET-UP FOLLOW-UP APPT IF APPLICABLE
AT CUST'S CELL PH ██████████
3. PLS UPDATE FILE WITH OUTCOME OF REVIEW AND ANY ACTION TAKEN TO ADDRESS
CUST'S REQUESTS OR CONCERNS AND CLOSE THE FILE.

THANK YOU

 DEALER PRINT, (05/02/06) (11:24) (BARL)
 ***** THANK YOU FOR YOUR ASSISTANCE IN RESOLVING OUR CUSTOMERS ISSUE. *****
 ***** IF YOU HAVE ANY QUESTIONS ABOUT THE FILE, CONTACT *****
 ***** CUSTOMER CONNECTIONS AT ██████████ TO SPEAK WITH A *****
 ***** VEHICLES CASE MANAGER. *****
 ***** CUSTOMER SATISFACTION AND RETENTION IS OUR FIRST PRIORITY! *****

05/05/06 VCM BARL...RECV'D VM FROM DPSM (PETB) ADVISED REVIEW FILE AND
 DECLINED ASSISTANCE DUE TO RECALL HAS BEEN PERFORMED ALMOST 5YRS AGO AND VEH

CONTINUATION OF FILE NO.: 0383731

REASON FOR CONTACT: REOPEN DT: OPEN CLOSE

FAR OUT OF WARR. DPSM STATED DLR 33023 SM WILL CLOSE FILE.

 &DATE REPAIR COMPLETED OR DECISION RENDERED : 05/05/2006
 &REPAIR ORDER NUMBER : NONE
 &MILEAGE AT REPAIR : 103000
 &COMMENTS INPUT BY : THERON LEDBETTER
 &ACTION TAKEN :
 & NO HELP GIVEN NOT WARRANTABLE REPAIR MILEAGE TO GREAT AND TIME ALSO SPOKE W
 &H DPSM BRIAN PETERS ADVISED NO ASSISTENCE.
 &*****
 &DEALER COMMENTS TRANSMITTED ON (05/05/2006) (33023AWS)
 &FILE CLOSED AS A RESULT OF TRANSMISSION
 &*****
 (05/15/06) (10:52) (LEMD): CUST CALLING FOR STATUS ON FILE. VCM ADV'D CUST OF
 DECLINE. CUST STATED HE ALSO FILED REPORT WITH DEPT OF TRANSPORTATION AND NOT
 HAPPY THAT THEY WOULD REPAIR. CUST AWARE BASIC WARRANTY IS 3YR/36,000 MILES
 AND THAT VEH REPAIRED AT 33,325 MILES AND NOW VEH PARTS WARRANTY ALSO EXPIRED

MATCHING CUSTOMER SERVICE CONTACT

NAME : [REDACTED] OPEN DATE: 20060515
 ADDRESS : [REDACTED] YUMA AZ [REDACTED] FILE NO: 0384117
 PHONE (W) : [REDACTED] EXT: [REDACTED] PHONE (H) : [REDACTED]
 VIN : JA4MW31R1 [REDACTED] YEAR/MODEL: 2001 MONTERO
 SERV DLR : 04053 LUZZI MITSUBISHI
 DELIVERY DATE: 06/30/00 MILEAGE: 107000 CLOSE DATE: 20060515
 GRP/SUB-GRP: SERVICE BRAKES BOOSTER, BRAKE, GENERAL
 COND/REMEDY: NOISE/KNOCK/RATTLE
 REASON FOR CONTACT: REOPEN DT: OPEN CLOSE
 (05/15/06) (09:37) (ATIM):

SERVICE BRAKES

 PREVIOUS FILE(S) :

MECHANICAL ISSUE # 1 : BRAKE ACCUMULATOR () PREVIOUS RPRS
 MECHANICAL ISSUE # 2 : () PREVIOUS RPRS
 MECHANICAL ISSUE # 3 : () PREVIOUS RPRS
 ORIGINAL OWNER : () YES; (X) NO, PURCH 12/02 AT --- MILES
 POLICY ADJUSTMENT REQUEST ... : () RENTAL; () OUT OF WARR REPAIR ; () OTHER
 PARTS DELAY/BACKORDER : () YES ; PART # ; ORDER #
 RETAILER SM/ADVISOR CONTACTED: () YES ; NAME :
 DPSM CONTACTED : () YES ; NAME :

 CUST STATES BRAKES ARE MAKING NOISE SAME AS STATED IN RECALL BULLETIN, HER
 HUSBAND WORKS AT DODGE AND THEY WILL REPAIR EVEN IF RECALL HAS BEEN COMPLETED
 VCM ADVISED BRAKE ACCUMULATOR RECALL WAS DONE 7/02, ANY REPAIRS NEEDED AT
 THIS TIME IS CUST PAY AS VEHICLE IS OUT OF WARRANTY.
 CUST UNDERSTOOD.

 05/15/06 ATIM:FILE CLOSED

MATCHING CUSTOMER SERVICE CONTACT

NAME : [REDACTED] OPEN DATE: 20060524
 ADDRESS : [REDACTED] CA [REDACTED] FILE NO: 0384630
 PHONE (W) : [REDACTED] EXT: [REDACTED] PHONE (H) : [REDACTED]
 VIN : JA4MW31R12 YEAR/MODEL: 2002 MONTERO
 SERV DLR : 05373 MODESTO MITS
 DELIVERY DATE: 01/25/02 MILEAGE: 70000 CLOSE DATE: 20060524
 GRP/SUB-GRP: SERVICE BRAKES BOOSTER, BRAKE, GENERAL
 COND/REMEDY: OPERATIONAL CONCERN
 REASON FOR CONTACT: REOPEN DT: OPEN CLOSE
 (05/24/06) (14:49) (BARL):

SERVICE BRAKES

PREVIOUS FILE(S) :
 MECHANICAL ISSUE # 1 : NOISE FROM DRIVER SIDE () PREVIOUS RPRS
 MECHANICAL ISSUE # 2 : OPEN RECALL C0408W FUEL LEVELER () PREVIOUS RPRS
 MECHANICAL ISSUE # 3 : N/A () PREVIOUS RPRS
 ORIGINAL OWNER : (X) YES; () NO, PURCH MM/YY AT --- MILES
 POLICY ADJUSTMENT REQUEST : () RENTAL; () OUT OF WARR REPAIR ; () OTHER
 PARTS DELAY/BACKORDER : () YES ; PART # ; ORDER #
 RETAILER SM/ADVISOR CONTACTED: () YES ; NAME ;
 DPSM CONTACTED : () YES ; NAME ;

CUST [REDACTED] CALLS MMNA UPSET BUT POLITE COMPLAINTS ABOUT A NOISE FROM
 DRIVER SIDE. CUST STATED THAT NAPA INFORMED THAT MITS MONTERO HAS A RECALL
 FOR THE: BRAKE BOOSTER ACCUMULATOR AND WAS REFERRED TO CONTACT THE NEAREST
 AUTH. MITS DLR. CUST CALLED MITS DLR IN MODESTO AND ONE DAY WAS TOLD YES HAS
 A RECALL AND THE OTHER DAY WAS TOLD NO RECALL FOR THIS. VCM APOLOGIZED FOR
 THE MISINFO. AND MADE IT VERY CLEAR TO CUST THAT VEH HAS ONE OPEN RECALL AND
 THAT IS: C0408W FUEL LEVELER THAT CUST WAS NOTIFIED BY MMNA ON 08/04 AND
 ADVISED CUST THE IMPORTANCE OF THE RECALL TO BE PERFORMED BY ANY AUTH. MITS
 DLR. HOWEVER FOR THE: BRAKE BOOSTER ACCUMULATOR ADVISED THIS VEH WAS NOT
 RECALLED. VCM EXPLAINED THAT AFFECTED VEHs PRODUCED BEFORE 06/20/01 AND THIS
 VEH WAS PRODUCED ON 09/26/01. CUST UNDERSTOOD AND ENDED CALL.
 (NO FURTHER ACTION REQUIRED, FILE CLOSED.)

05/24/06 BARL:FILE CLOSED

MATCHING CUSTOMER SERVICE CONTACT

NAME : [REDACTED] OPEN DATE: 20060526
ADDRESS : [REDACTED] CHULA VISTA CA [REDACTED] FILE NO: 0384509
PHONE (W) : [REDACTED] PHONE (H) : [REDACTED]
VIN : JA4MW51R41 YEAR/MODEL: 2001 MONTERO
SERV DLR : 46056 FIRST TEAM MITS
DELIVERY DATE: 04/21/00 MILEAGE: 89253 CLOSE DATE: 20060530
GRP/SUB-GRP: SERVICE BRAKES BOOSTER, BRAKE, GENERAL
COND/REMEDY: NOISE/KNOCK/RATTLE
REASON FOR CONTACT: REOPEN DT: OPEN CLOSE
(05/26/06) (09:01) (BARL):

SERVICE BRAKES

PREVIOUS FILE(S) :
MECHANICAL ISSUE # 1 : NOISE FROM DRIVER SIDE (BRAKE ACCUMULATOR) () PRV RPRS
MECHANICAL ISSUE # 2 : N/A () PREVIOUS RPRS
MECHANICAL ISSUE # 3 : N/A () PREVIOUS RPRS
ORIGINAL OWNER: (X) YES; () NO, PURCH MM/YY AT --- MILES
POLICY ADJUSTMENT REQUEST ...: () RENTAL; () OUT OF WARR REPAIR; () OTHER
PARTS DELAY/BACKORDER: () YES; PART # : ORDER #
RETAILER SM/ADVISOR CONTACTED: (X) YES; NAME : TALKED TO SM MARK ..@09:02AM
DPSM CONTACTED: (X) YES; NAME : LEFT VM TO DPSM SPEK...@09:14AM

CUST [REDACTED] CALLS MMNA CURRENTLY AT DLR 46056 FOR NOISE FROM DRIVER SIDE AND CUST SEARCHED CONCERN FURTHER AND FOUND OUT THAT SYMPTONS ARE SIMILAR RELATED TO THE RECALL FOR THE BRAKE ACCUMULATOR AND CUST SEEK MMNA ASSISTANC-E. VCM ADVISED RECALL WAS PERFORMED ON 12/04/01. CUST UNDERSTANDS HOWEVER WAS TOLD RECALL WAS INSPECTED AND NO PARTS WERE REPLACED. VCM ASKED CUST TO PLS HOLD WHILE CALLING DLR 46056.
(VCM CALLED DLR 46056 @09:02AM TALKED TO SM MARK STEVENS STATED THAT CUST NEEDS TO AUTHORIZED DIAGNOSIS FIRST TO DETERMINE CONCERN AND WAS ADVISED ""IF"" IS THE BRAKE ACCUMULATOR SM WILL IMMEDIATELY REVIEW CONCERN WITH DPSM) VCM WENT BACK TO CUST APOLOGIZED FOR THE HOLD TIME AND ADVISED CUST IN ORDER FOR SM TO REVIEW CONCERN FURTHER TO PLEASE AUTHORIZED DLR 46056 DIAGNOSIS TO DETERMINE ASSISTANCE. VCM MADE IT CLEAR TO CUST NO GUARANTEES. CUST UNDERSTOOD AND WILL AUTHORIZED DLR DIAGNOSIS.
(VCM LFT VM TO DPSM SPEK...@09:14AM.)

DEALER SERVICE MANAGER, PLEASE RESOLVE

1. PLS REVIEW FILE WITH YOUR DPSM TO DETERMINE ACTION TO BE TAKEN.
2. PLS CONTACT CUST IN RESPONSE TO THEIR CALL TO MMNA AND ADVISE OF DECISION RENDERED OR ACTION PLAN AT CUST'S PH [REDACTED]
3. PLS UPDATE FILE WITH OUTCOME OF REVIEW AND ANY ACTION TAKEN TO ADDRESS CUST'S REQUESTS OR CONCERNS AND CLOSE THE FILE.

THANK YOU

DEALER PRINT, (05/26/06) (09:16) (BARL)
***** THANK YOU FOR YOUR ASSISTANCE IN RESOLVING OUR CUSTOMERS ISSUE. *****
***** IF YOU HAVE ANY QUESTIONS ABOUT THE FILE, CONTACT *****
***** CUSTOMER CONNECTIONS AT 888-908-6672 TO SPEAK WITH A *****
***** VEHICLES CASE MANAGER. *****
***** CUSTOMER SATISFACTION AND RETENTION IS OUR FIRST PRIORITY! *****

CONTINUATION OF FILE NO.: 0384509

REASON FOR CONTACT: REOPEN DT: OPEN CLOSE

```

*****
&DATE CUSTOMER CONTACTED      : 05/26/2006  DATE COMMENTS ENTERED: 05/27/2006
&CONTACTED BY                 : SPEK
&CUSTOMER APPOINTMENT DATE    :
&DPSM INSPECTION PENDING      : NO    DATE:
&BACK ORDERED PART # (S)      :
&PARTS ORDER D-S-SHO # (S)    :
&TECHLINE ASSISTANCE PENDING  : NO    IF YES, RESOLUTION IN SUMMARY
&SUMMARY OF CONTACT           :
&REVIEWED CUSTOMER CONCERN WITH BILL, MITSUBISHI ADVISOR, GAVE AUTHORIZATION
&TO REPLACE ACCUMULATOR - GOODWILL KEN SPETH
*****
&DEALER COMMENTS TRANSMITTED ON (05/27/2006) (KSPETH )
&FILE UPDATED AS A RESULT OF TRANSMISSION
*****
&DATE REPAIR COMPLETED OR DECISION RENDERED : 05/30/2006
&REPAIR ORDER NUMBER          : ██████████
&MILEAGE AT REPAIR            : 89253
&COMMENTS INPUT BY           : MAS
&ACTION TAKEN                 :
&MMSA REP GOODWILLED REPAIRS RELATED TO NOISE BRAKE BOOSTER CONCERN.
*****
&DEALER COMMENTS TRANSMITTED ON (05/30/2006) (46056ATH)
&FILE CLOSED AS A RESULT OF TRANSMISSION
*****

```

MATCHING CUSTOMER SERVICE CONTACT

NAME : [REDACTED] OPEN DATE: 20060605
 ADDRESS : [REDACTED] HOLLAND MI [REDACTED] FILE NO: 0384727
 PHONE (W) : [REDACTED] EXT: [REDACTED] PHONE (H) : [REDACTED]
 VIN : JA4MW31R2 [REDACTED] YEAR/MODEL: 2001 MONTERO
 SERV DLR : 23064 CROWN MITS-MI
 DELIVERY DATE: 07/21/00 MILEAGE: 81000 CLOSE DATE: 20060605
 GRP/SUB-GRP: SERVICE BRAKES BOOSTER, BRAKE, GENERAL
 COND/REMEDY: OPERATIONAL CONCERN
 REASON FOR CONTACT: REOPEN DT: OPEN CLOSE
 (06/05/06) (08:47) (BARL);

SERVICE BRAKES

PREVIOUS FILE(S) :
 MECHANICAL ISSUE # 1 : NOISE FROM DRIVER SIDE (BRAKE ACCUMULATOR) (X) PRVS RPRS
 MECHANICAL ISSUE # 2 : N/A () PREVIOUS RPRS
 MECHANICAL ISSUE # 3 : N/A () PREVIOUS RPRS
 ORIGINAL OWNER: () YES; (X) NO, PURCH 01/01 AT 37,000 MILES
 POLICY ADJUSTMENT REQUEST ...: () RENTAL; () OUT OF WARR REPAIR; () OTHER
 PARTS DELAY/BACKORDER: () YES; PART # ; ORDER #
 RETAILER SM/ADVISOR CONTACTED: () YES; NAME :
 DPSM CONTACTED: () YES; NAME :

CUST'S SON K [REDACTED] CALLS IN BEHALF OF HIS FATHER (OWNER) MR [REDACTED]
 REGARDING NOISE FROM DRIVER SIDE AND ABS LIGHT ON. MR PEREZ WENT TO DLR 23064
 AND WAS ADVISED COULD BE THE BRAKE ACCUMULATOR HOWEVER VEH WAS NOT DIAGNOSED.
 CUST SEEK FROM MMNA ASSISTANCE. VCM ADVISED VEH FAR OOW. VCM EXPLAINED RECALL
 HAS BEEN PERFORMED ON 11/27/01 AT PAYNE MITS IN TEXAS AND PART WAS REPLACED.
 CUST'S SON REQUESTED PART# VCM PROVIDED INFO. CUST'S SON UNDERSTOOD AND ENDED
 CALL. (NO FURTHER ACTION REQUIRED. FILE CLOSED.)

06/05/06 BARL:FILE CLOSED

CONFIDENTIAL

 MITSUBISHI MOTOR SALES OF AMERICA, Inc.		PRODUCT QUALITY REPORT Rec No. 16172		POR No. CK45 -35 -0000-5-	DATE OF ISSUE 2/6/2001 REPORTER ID/SEQ.# 1869 / 3	
YEAR NAME OF VEHICLE / PRICE LINE 2001 MONTERO SUV 7 PASSENGER / XLS		VEHICLE IDENTIFICATION No./CHASSIS No. JA4MW31R91		DISTRIBUTOR MMSA	ACCY ENG N	PRIORITY S
ENGINE NO. 6G74 -3.5	TM TYPE A	MFG DATE 4/25/2000	REAR BODY (MODIFICATION) N/A	LOCATION: 35133 VALLEY STREAM MITSUBISHI		USAGE RETAIL CAR
DATE SOLD 7/2/2000		DATE / MILEAGE TROUBLE OCCURRED 1/23/2001 / 6846		STATE NY	REGION / DISTRICT 20 / B1	
VEHICLE / ENGINE SPEED N/A		ROAD CONDITION N/A	LOAD CONDITION N/A	WEATHER / TEMPERATURE N/A / N/A		MAINTENANCE GOOD
SUBJECT HBB - BRAKE PEDAL IS SPONGY AND VEHICLE IS HARD TO STOP.					FREQUENCY: FIRST FREQUENT: 1 UNITS	
1 DESCRIPTION OF SYMPTOM CUSTOMER STATES BRAKES LOCK-UP, TECH STATES BRAKE PEDAL IS SPONGY AND VEHICLE IS HARD TO STOP					CONDITION	
DTC(S):						
2 POSSIBLE CAUSE BRAKE ACCUMULATOR						
3 ACTION TAKEN / RESULT A NEW BRAKE ACCUMULATOR FIXED THE VEHICLE.						
4. ADDITIONAL COMMENTS <p style="text-align: center;">THE BRAKE PEDAL WAS SPONGY KEY ON. IF YOU PUSHED HARD ON THE BRAKE PEDAL KEY ON, THE HYDRAULIC PUMP MOTOR WOULD COME ON. KEY OFF IF YOU PUSHED ON THE BRAKE PEDAL YOU WOULD NOTICE THE PEDAL WAS ALREADY HARD LIKE THE ACCUMULATOR WAS NOT HOLDING ANY RESERVE PRESSURE</p>						
REPORTER'S NAME/SIGNATURE						D.Griffith
5. MANUFACTURERS RESPONSES/COMMENTS <p style="text-align: center;">REPORT HAS BEEN SUBMITTED TO MANUFACTURER FOR REVIEW</p>						
MANUFACTURER'S NAME/SIGNATURE						
MMSA CONTROL #: -----				RO/CLAIM:		
PART #: MR527718	PART DESCRIPTION:		PART REQ'D DATE: PART RECV'D DATE:	PART SENT TO:		
IQS CATEGORY: A	IQS QUESTION:	KMODEL: V75WLRHVL2M	BODY MODEL:	PROD. ENGINEER: JR		
CURRENT STATUS, DATE: MOPN , 2/7/2001		DATE TO MFG: 2/6/2001	DATE MFG HOLD:	DATE FROM MFG:		

CONFIDENTIAL

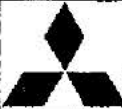
 MITSUBISHI MOTOR SALES OF AMERICA, Inc.		PRODUCT QUALITY REPORT Rec No. 16186		PQR No. CK45 -35 -0000-3-S	DATE OF ISSUE 2/16/2001 REPORTER ID/SEQ.# 05312 / 2	
YEAR NAME OF VEHICLE / PRICE LINE 2001 MONTERO SUV 7 PASSENGER / XLS		VEHICLE IDENTIFICATION No./CHASSIS No. JA4MW31R91		DISTRIBUTOR MMSA	ACCY ENG. N	PRIORITY A
ENGINE NO. 6Q74 -3.5	TM TYPE A	MFG DATE 5/10/2000	REAR BODY (MODIFICATION) N/A	LOCATION: 05312 COURTESY MITSUBISHI		USAGE RETAIL CAR
DATE SOLD 5/31/2000		DATE / MILEAGE TROUBLE OCCURRED 2/16/2001 / 15819		STATE CA	REGION / DISTRICT 10 / L4	
VEHICLE / ENGINE SPEED N/A		ROAD CONDITION N/A	LOAD CONDITION N/A	WEATHER / TEMPERATURE N/A / N/A		MAINTENANCE GOOD
SUBJECT HBB UNIT - NOISY				FREQUENCY: FIRST FREQUENT: 1 UNITS		
1. DESCRIPTION OF SYMPTOM CUSTOMER STATES THAT THE VEHICLE MAKE A CHIRPING WHEN BRAKE PEDAL IS DEPRESSED.				CONDITION		
DTC(S):		55				
2. POSSIBLE CAUSE BRAKE ACCUMULATOR RUPTURED.						
3. ACTION TAKEN / RESULT THE ACCUMULATOR WAS REPLACED AND THE CONDITION WAS CORRECTED.						
4. ADDITIONAL COMMENTS						
				REPORTER'S NAME/SIGNATURE COURTESY MITSUBISHI		
5. MANUFACTURERS RESPONSES/COMMENTS REPORT HAS BEEN SUBMITTED TO MANUFACTURER FOR REVIEW 02/9/12 MMC RESPONSE : PLEASE REFER OUR RESPONSE TO PQR NO.CK45-35-3-S (VIN 1J000634) DATED 01/9/3.						
				MANUFACTURER'S NAME/SIGNATURE		
MMA CONTROL #: -----				RO/CLAIM: 24749		
PART #: MR527718		PART DESCRIPTION: ACCUMULATOR,BRAKE BOOSTER		PART REQ'D DATE: PART REC'D DATE:		
PART SENT TO:		IQS CATEGORY: A		IQS QUESTION: 3 -		
KMODEL: V75WLRHVL2M		BODY MODEL:		PROD. ENGINEER: JR		
CURRENT STATUS, DATE: MRSP , 9/12/2002		DATE TO MFG: 2/20/2001		DATE MFG HOLD: 9/12/2002		
CONTACT:		PHONE NUMBER:		FAX NUMBER:		

CONFIDENTIAL

 MITSUBISHI MOTOR SALES OF AMERICA, Inc.		PRODUCT QUALITY REPORT Rec No. 16416		PQR No. CK45 -35 -0000-3-S	DATE OF ISSUE 8/14/2001 REPORTER ID/SEQ.# 44156 / 2	
YEAR NAME OF VEHICLE / PRICE LINE 2001 MONTERO SUV 7 PASSENGER / LIMITED		VEHICLE IDENTIFICATION No. JA4MW51R61		DISTRIBUTOR MMSA	ACCY ENG. N	PRIORITY A
ENGINE NO. 6G74 -3.5	TM TYPE S	MFG DATE 1/17/2000	REAR BODY (MODIFICATION) N/A	LOCATION: 44156 WEST LOOP MITSUBISHI-SAN ANTONIO		USAGE RETAIL CAR
DATE SOLD 10/25/2000		DATE / MILEAGE TROUBLE OCCURRED 8/14/2001 / 20966		STATE TX	REGION / DISTRICT 40 / D6	
VEHICLE / ENGINE SPEED N/A		ROAD CONDITION N/A	LOAD CONDITION N/A	WEATHER / TEMPERATURE N/A / N/A		MAINTENANCE GOOD
SUBJECT HBB UNIT - NOISY					FREQUENCY: SOMETIMES FREQUENT: 3 UNITS	
1. DESCRIPTION OF SYMPTOM CHIRPING NOISE WHEN APPLING BRAKES					CONDITION	
DTC(S):						
2. POSSIBLE CAUSE DEPLETED ACCUMULATOR						
3. ACTION TAKEN / RESULT REPLACED ACCUMULATOR						
4. ADDITIONAL COMMENTS						
REPORTER'S NAME/SIGNATURE WEST LOOP MITSUBISHI-SAN /						
5. MANUFACTURERS RESPONSES/COMMENTS SAFETY RECALL CAMPAIGN WILL BE LAUNCHED AS SOON AS MMSA PREPARES THE ENOUGH COUNTERMEASURE PARTS. WE WOULD LIKE TO CLOSE THIS PQR. M.MIYASHITA, MMC-IASD 9/3/01						
MANUFACTURER'S NAME/SIGNATURE						
MMMA CONTROL #: -----				RO/CLAIM:		
PART #: MR977411	PART DESCRIPTION: ACCUMULATOR ASSY,BRAKE BOOSTER		PART REC'D DATE: PART RECVD DATE:	PART SENT TO:		
IQS CATEGORY: A	IQS QUESTION: 3 -	KMODEL: V75WLYXVL2M	BODY MODEL:	PROD. ENGINEER: JR		
CURRENT STATUS, DATE MRSP , 9/2/2001		DATE TO MFG: 8/21/2001	DATE MFG HOLD:	DATE FROM MFG: 9/2/2001		

CONFIDENTIAL

 MITSUBISHI MOTOR SALES OF AMERICA, Inc.		PRODUCT QUALITY REPORT Rec No. 16540		POR No. CK45 -35 -0000-3-S	DATE OF ISSUE 10/24/2001 REPORTER ID/SEQ.# 1869 / 15	
YEAR NAME OF VEHICLE / PRICE LINE 2001 MONTERO SUV 7 PASSENGER / LIMITED		VEHICLE IDENTIFICATION / CHASSIS No. JA4MW51R41		DISTRIBUTOR MMSA	ACCY ENG. N	PRIORITY B
ENGINE NO. 6G74 -3.5	TM TYPE A	MFG DATE 1/24/2000	REAR BODY (MODIFICATION) N/A	LOCATION: 32065 PRESTIGE MITSUBISHI		USAGE RETAIL CAR
DATE SOLD 4/10/2000	DATE / MILEAGE TROUBLE OCCURRED 10/24/2001 / 24879			STATE NJ	REGION / DISTRICT 20 / B3	
VEHICLE / ENGINE SPEED N/A	ROAD CONDITION N/A	LOAD CONDITION N/A	WEATHER / TEMPERATURE N/A / N/A		MAINTENANCE GOOD	
SUBJECT HBB UNIT - NOISY					FREQUENCY: SOMETIMES FREQUENT: 1 UNITS	
1. DESCRIPTION OF SYMPTOM A CHIRPING NOISE COMING FROM THE BRAKES WHEN THE BRAKE PEDAL IS PRESSED, 6 DAYS AFTER THE RECALL FOR THE BRAKE ACCUMULATOR WAS PERFORMED					CONDITION	
DTC(S):						
2. POSSIBLE CAUSE THE TECH STATED THE ACCUMULATOR THAT FAILED HAS A PINK DOT ON IT.						
3. ACTION TAKEN / RESULT REPLACING THE BRAKE ACCUMULATOR FIXED THIS VEHICLE. THE PART HAS ALREADY BEEN RETURNED TO THE WARRANTY RETURN CENTER.						
4. ADDITIONAL COMMENTS 1J032089 HAD THE SAME CONCERN. AN ACCUMULATOR WITH A PINK DOT FAILED JUST AFTER THE RECALL FOR THE BRAKE ACCUMULATOR WAS PERFORMED.						
REPORTER'S NAME/SIGNATURE D.Griffith						
5. MANUFACTURERS RESPONSES/COMMENTS WE HAVE ALREADY INFORMED OUR INVESTIGATION RESULT TO MMA-PSC DIRECTLY. PLEASE HAVE DEALER TECHNICIANS PAY ATTENTION TO THE ACCUMULATOR SPRING AT THE ACCUMULATOR INSTALLATION. (CAR MEETING ITEM) M. MIYASHITA, MMC-IASD 12/20/2001						
MANUFACTURER'S NAME/SIGNATURE						
MMA CONTROL #: *****				RO/CLAIM: 103453		
PART #: MR977223	PART DESCRIPTION: ACCUMULATOR,BRAKE BOOSTER			PART REC'D DATE: PART REC'D DATE:	PART SENT TO:	
IQS CATEGORY: A	IQS QUESTION: 3 -	KMODEL: V75WLYXVL2M	BODY MODEL:	PROD. ENGINEER: JR		
CURRENT STATUS, DATE:	DATE TO MFG: 10/24/2001	DATE MFG HOLD:	DATE FROM MFG: 12/23/2001			

CONFIDENTIAL

 MITSUBISHI MOTOR SALES OF AMERICA, Inc.		PRODUCT QUALITY REPORT Rec No. 16548		PQR No. CK45 -35 -0000-7-	DATE OF ISSUE 10/24/2001 REPORTER ID/SEQ.# 15010 / 5	
YEAR NAME OF VEHICLE / PRICE LINE 2001 MONTERO SUV 7 PASSENGER / LIMITED		VEHICLE IDENTIFICATION No. / CHASSIS No. JA4MW51R21		DISTRIBUTOR MMSA	ACCY ENG. N	PRIORITY B
ENGINE NO. 6G74 -3.5	TM TYPE S	MFG DATE 12/11/2000	REAR BODY (MODIFICATION) N/A	LOCATION: 15010 PARKWAY MITSUBISHI-IL		USAGE RETAIL CAR
DATE SOLD 10/15/2001		DATE / MILEAGE TROUBLE OCCURRED 10/24/2001 / 915		STATE IL	REGION / DISTRICT 50 / C4	
VEHICLE / ENGINE SPEED N/A		ROAD CONDITION N/A	LOAD CONDITION N/A	WEATHER / TEMPERATURE N/A / N/A		MAINTENANCE GOOD
SUBJECT FAILURE OF ACCUMULATOR AFTER COUNTERMEASURE					FREQUENCY: FIRST FREQUENT: 1 UNITS	
1. DESCRIPTION OF SYMPTOM CUSTOMER STATES NO BRAKES & NOISE WHILE BRAKING					CONDITION	
DTC(S):						
2. POSSIBLE CAUSE NITROGEN GAS LEAKED FROM ACCUMULATOR						
3. ACTION TAKEN / RESULT REPLACED ACCUMULATOR ASSEMBLY						
4. ADDITIONAL COMMENTS <p style="text-align: center;">RECALL SR-01-008 WAS PERFORMED ON 09/25/01 WHILE VEHICLE WAS STILL ON STOCK. VEHICLE HAD 43 MILES AND RO#142211. MMSA REQUESTED THIS PART BACK ON 10/25/01. MMSA INSTALLED THE RETURNED PART ON MR INOUE VEHICLE AND FOUND PART DEFECTIVE 10/31/01.</p>						
					REPORTER'S NAME/SIGNATURE PARKWAY MITSUBISHI-IL	
5. MANUFACTURERS RESPONSES/COMMENTS 02/8/29 MMC RESPONSE : WE HAVE ALREADY INFORMED OUR INVESTIGATION RESULT TO MMA-PSC DIRECTLY. PLEASE HAVE DEALER TECHNICIANS PAY ATTENTION TO THE ACCUMULATOR SPRING AT THE ACCUMULATOR INSTALLATION. (CAR MEETING ITEM)						
					MANUFACTURER'S NAME/SIGNATURE	
MMA CONTROL #: *****				RO/CLAIM: Z8388		
PART #: MR977223	PART DESCRIPTION: ACCUMULATOR,BRAKE BOOSTER			PART REC'D DATE: PART REC'D DATE:	PART SENT TO: /	
IQS CATEGORY: A	IQS QUESTION: 3 -	KMODEL: V75WLYXVL2M	BODY MODEL:	PROD. ENGINEER: JR		
CURRENT STATUS, DATE:		DATE TO MFG.	DATE MFG HOLD:	DATE FROM MFG:		

CONFIDENTIAL

 MITSUBISHI MOTOR SALES OF AMERICA, Inc.		PRODUCT QUALITY REPORT Rec No. 16635		PQR No. CK45 -36 -0000-7-S	DATE OF ISSUE 11/21/2001 REPORTER ID/SEQ.# 1869 / 16
YEAR NAME OF VEHICLE / PRICE LINE 2001 MONTERO SUV 7 PASSENGER / LIMITED		VEHICLE IDENTIFICATION NO. / CHASSIS No. JA4MW51R81	DISTRIBUTOR MMSA	ACQY ENG. N	PRIORITY B
ENGINE NO 6G74 -3.5	TM TYPE S	MFG DATE 11/9/2000	REAR BODY (MODIFICATION) N/A	LOCATION: 48061 FIVE STAR MITSUBISHI	
DATE SOLD 1/8/2001		DATE / MILEAGE TROUBLE OCCURRED 11/20/2001 / 9155		STATE WA	REGION / DISTRICT 10 / L6
VEHICLE / ENGINE SPEED 20	ROAD CONDITION N/A	LOAD CONDITION N/A	WEATHER / TEMPERATURE N/A / N/A	MAINTENANCE GOOD	
SUBJECT FAILURE OF ACCUMULATOR AFTER COUNTERMEASURE				FREQUENCY: FIRST FREQUENT: 1 UNITS	
1. DESCRIPTION OF SYMPTOM VEHICLE HAD BRAKE ACCUMULATOR REPLACEMENT RECALL PERFORMED ON 10-12-01. THE VEHICLE CAME BACK 11-20-01 WITH A COMPLAINT OF A NOISE AT 20 MPH AND BELOW WHEN APPLYING THE BRAKES.				CONDITION	
DTC(S):					
2. POSSIBLE CAUSE ACCUMULATOR REPLACED DURING THE RECALL FAILED.					
3. ACTION TAKEN / RESULT REPLACING THE ACCUMULATOR FIXED THIS NOISE.					
4. ADDITIONAL COMMENTS <p style="text-align: center;">TECH-LINE INSTRUCTED DEALER TO SEND THE ACCUMULATOR BACK TO MMSA PSC ATTENTION TO RICK LANTZ. PARTS RECEIVED 11/29/01 AND NO PROBLEM FOUND AT THIS TIME.</p>					
				REPORTER'S NAME/SIGNATURE D.Griffith	
5. MANUFACTURERS' RESPONSES/COMMENTS <p style="text-align: center;">WE HAVE ALREADY INFORMED OUR INVESTIGATION RESULT TO MMA-PSC DIRECTLY. PLEASE HAVE DEALER TECHNICIANS PAY ATTENTION TO THE ACCUMULATOR SPRING AT THE ACCUMULATOR INSTALLATION. (CAR MEETING ITEM) M. MIYASHITA MMC-IASD, 12/20/2001</p>					
				MANUFACTURER'S NAME/SIGNATURE	
MMMA CONTROL #: -----				RO/CLAIM: 24002	
PART #	PART DESCRIPTION:	PART REQ'D DATE: PART RECVD DATE:	PART SENT TO:		
IQS CATEGORY: A	IQS QUESTION: 3 -	KMODEL: V75WLYXVL2M	BODY MODEL:	PROD. ENGINEER: JR	
CURRENT STATUS, DATE:		DATE TO MFG:	DATE MFG HOLD:	DATE FROM MFG:	

CONFIDENTIAL

 MITSUBISHI MOTOR SALES OF AMERICA, Inc.		PRODUCT QUALITY REPORT Rec No. 16863		PQR No. CK45 -35 -0000-11-	DATE OF ISSUE 2/28/2002 REPORTER ID/SEQ.# 1200 / 7	
YEAR NAME OF VEHICLE / PRICE LINE 2002 MONTERO SUV 7 PASSENGER / LIMITED		VEHICLE IDENTIFICATION NO. / CHASSIS No. JA4MW51R32J		DISTRIBUTOR MMSA	AGCY ENG. N	PRIORITY B
ENGINE NO. 6G74 -3.5	TM TYPE S	MFG DATE 8/20/2001	REAR BODY (MODIFICATION) N/A	LOCATION: 00 NATIONAL		USAGE RETAIL CAR
DATE SOLD 9/29/2001		DATE / MILEAGE TROUBLE OCCURRED 2/28/2002 / 3543		STATE NATIONAL	REGION / DISTRICT /	
VEHICLE / ENGINE SPEED N/A		ROAD CONDITION N/A	LOAD CONDITION N/A	WEATHER / TEMPERATURE N/A / N/A		MAINTENANCE GOOD
SUBJECT NOISY ELECTRIC HBB PUMP MOTOR.					FREQUENCY: FIRST FREQUENT: 1 UNITS	
1. DESCRIPTION OF SYMPTOM AFTER APPLYING PRESSURE ON THE BRAKE PEDAL THE DRIVER REPORTS HEARING THE ELECTRIC PUMP MOTOR OF THE HBB RUNNING FOR APPROXIMATELY 1 TO 2 SECONDS. THIS CONDITION OCCURS AFTER EVERY BRAKE APPLICATION.					CONDITION	
DTC(S):						
2. POSSIBLE CAUSE UNKNOWN, THIS UNIT IS LOUDER THAN OTHER VEHICLES UNDER THE SAME CONDITION.						
3. ACTION TAKEN / RESULT NO REPAIR WORK AT THIS TIME.						
4. ADDITIONAL COMMENTS						
					REPORTER'S NAME/SIGNATURE R.Lantz	
5. MANUFACTURERS RESPONSES/COMMENTS REPORT HAS BEEN SUBMITTED TO MANUFACTURER FOR REVIEW 02/12/17 MMC RESPONSE: AS THE PROBLEM SEEMS TO BE RARE CASES, WE WILL WATCH THE FIELD CONDITION FOR THE TIME BEING.						
					MANUFACTURER'S NAME/SIGNATURE	
MMA CONTROL #: -----				RO/CLAIM: N/S		
PART #	PART DESCRIPTION:		PART REQ'D DATE: PART REC'D DATE:	PART SENT TO:		
IQS CATEGORY: A	IQS QUESTION: -	KMODEL: V76WLYXVL2M	BODY MODEL:	PROD. ENGINEER: JR		
CURRENT STATUS, DATE: MRSP, 12/17/2002		DATE TO MFG: 2/28/2002	DATE MFG HOLD:	DATE FROM MFG: 12/17/2002		

CONFIDENTIAL

 MITSUBISHI MOTOR SALES OF AMERICA, Inc.		PRODUCT QUALITY REPORT Rec No. 17255		PQR No. CK45 -35 -0000-7-S	DATE OF ISSUE 7/3/2002 REPORTER ID/SEQ.# 1869 / 37	
YEAR NAME OF VEHICLE / PRICE LINE 2002 MONTERO SUV 7 PASSENGER / XLS		VEHICLE IDENTIFICATION No./CHASSIS No. JA4MW31R22J		DISTRIBUTOR MMSA	ACCY ENG. N	PRIORITY B
ENGINE NO. 6G74 -3.5	TM TYPE A	MFG DATE 5/30/2001	REAR BODY (MODIFICATION) N/A	LOCATION: 04056 AVONDALE MITSUBISHI		USAGE RETAIL CAR
DATE SOLD 7/27/2001	DATE / MILEAGE TROUBLE OCCURRED 7/3/2002 / 28352		STATE AZ	REGION / DISTRICT 40 / D4		
VEHICLE / ENGINE SPEED N/A	ROAD CONDITION N/A	LOAD CONDITION N/A	WEATHER / TEMPERATURE N/A / N/A		MAINTENANCE GOOD	
SUBJECT FAILURE OF ACCUMULATOR AFTER COUNTERMEASURE					FREQUENCY: FIRST FREQUENT: 1 UNITS	
1. DESCRIPTION OF SYMPTOM THE TECH INSTALLED A NEW ACCUMULATOR WITH A PINK DOT AS PER SR 01 008 REV II, THEN THE BRAKE PEDAL BECAME HARD AND THE HBB UNIT MADE A CHIRPING NOISE WHEN PRESSING ON THE BRAKES. THE TECH STATED THAT THE PART HE INSTALLED WAS AN ACCUMULATOR WITH THE PINK DOT AND HE CHECKED THE PIN AND SPRING ORIENTATION TO BE CORRECT.					CONDITION	
DTC(S):						
2. POSSIBLE CAUSE A FAILED NEW PINK DOT ACCUMULATOR						
3. ACTION TAKEN / RESULT THE TECH REPLACED THE PINK DOT ACCUMULATOR WITH A NEW PINK ACCUMULATOR DOT TO FIX THIS VEHICLE						
4. ADDITIONAL COMMENTS <p style="text-align: center;">THE VEHICLE BRAKING SYSTEM WAS FUNCTIONING NORMAL UNTIL THE RECALL WAS PERFORMED.</p>						
REPORTER'S NAME/SIGNATURE						D.Griffith
5. MANUFACTURERS RESPONSES/COMMENTS <p style="text-align: center;">REPORT HAS BEEN SUBMITTED TO MANUFACTURER FOR REVIEW 02/8/29 MMC RESPONSE : WE HAVE ALREADY INFORMED OUR INVESTIGATION RESULT TO MMA-PSC DIRECTLY. PLEASE HAVE DEALER TECHNICIANS PAY ATTENTION TO THE ACCUMULATOR SPRING AT THE ACCUMULATOR INSTALLATION. (CAR MEETING ITEM)</p>						
MANUFACTURER'S NAME/SIGNATURE						
MMMA CONTROL #: - - - - -				RO/CLAIM: 129327		
PART #: MR977223	PART DESCRIPTION: ACCUMULATOR,BRAKE BOOSTER		PART REQ'D DATE: PART RECV'D DATE:	PART SENT TO:		
IQS CATEGORY: A	IQS QUESTION: -	KMODEL: V75WLRHVL2M	BODY MODEL:	PROD. ENGINEER: JR		
CURRENT STATUS, DATE: MRSP, 8/28/2002		DATE TO MFG: 7/3/2002	DATE MFG HOLD:	DATE FROM MFG: 8/28/2002		

CONFIDENTIAL

 MITSUBISHI MOTOR SALES OF AMERICA, Inc.		PRODUCT QUALITY REPORT Rec No. 17290		PQR No. CK45 -35 -0000-7-S	DATE OF ISSUE 7/29/2002 REPORTER ID/SEQ.# 1869 / 42	
YEAR NAME OF VEHICLE / PRICE LINE 2001 MONTERO SUV 7 PASSENGER / LIMITED		VEHICLE IDENTIFICATION No./CHASSIS No. JA4MW51R31J [REDACTED]		DISTRIBUTOR MMSA	ACCY ENG. N	PRIORITY B
ENGINE NO. 6G74 -3.5	TM TYPE A	MFG DATE 1/18/2000	REAR BODY (MODIFICATION) N/A	LOCATION: 50002 MOSES MITSUBISHI		USAGE RETAIL CAR
DATE SOLD 3/31/2000		DATE / MILEAGE TROUBLE OCCURRED 7/29/2002 / 23661		STATE WV	REGION / DISTRICT 20 / BD	
VEHICLE / ENGINE SPEED N/A		ROAD CONDITION N/A	LOAD CONDITION N/A	WEATHER / TEMPERATURE N/A / N/A		MAINTENANCE GOOD
SUBJECT FAILURE OF ACCUMULATOR AFTER COUNTERMEASURE				FREQUENCY: FIRST FREQUENT: 1 UNITS		
1. DESCRIPTION OF SYMPTOM THE ACCUMULATOR WITH A PINK DOT WAS REPLACED DURING THE RECALL FOR THE ACCUMULATOR. AFTER REPLACEMENT THE VEHICLE SET A HBB CODE 78 AND AN ABS CODE 55. IF THE KEY WERE TURNED OFF THE BRAKE PEDAL WOULD BECOME HARD AFTER ONLY 3 PUMPS. WHEN THE KEY WAS TURNED BACK ON THE HBB HYDRAULIC PUMP WOULD ONLY RUN FOR 3 SECONDS.				CONDITION		
DTC(S):		HBB 78	ABS 55			
2. POSSIBLE CAUSE THE ACCUMULATOR WITH THE PINK DOT FAILED.						
3. ACTION TAKEN / RESULT THE ACCUMULATOR WAS REPLACED WITH ANOTHER ACCUMULATOR WITH A PINK DOT AND THE PROBLEM WAS GONE. BOTH OF THESE PARTS CAME FROM THE DEALERSHIPS OWN PARTS INVENTORY.						
4. ADDITIONAL COMMENTS <p style="text-align: center;">THE TECHNICIAN ASSURED ME THAT ALL OF THE PARTS RELATING TO THE HBB SYSTEM WERE INSTALLED CORRECTLY DURING PERFORMING THE RECALL.</p>						
				REPORTER'S NAME/SIGNATURE D.Griffith		
5. MANUFACTURERS RESPONSES/COMMENTS <p style="text-align: center;">REPORT HAS BEEN SUBMITTED TO MANUFACTURER FOR REVIEW 02/8/29 MMC RESPONSE : WE HAVE ALREADY INFORMED OUR INVESTIGATION RESULT TO MMA-PSC DIRECTLY. PLEASE HAVE DEALER TECHNICIANS PAY ATTENTION TO THE ACCUMULATOR SPRING AT THE ACCUMULATOR INSTALLATION. (CAR MEETING ITEM)</p>						
				MANUFACTURER'S NAME/SIGNATURE		
MMA CONTROL #: -----			RO/CLAIM: 121157			
PART #: MR977223	PART DESCRIPTION: ACCUMULATOR, BRAKE BOOSTER		PART REQ'D DATE: PART REC'VD DATE:	PART SENT TO:		
IQS CATEGORY: A	IQS QUESTION:	KMODEL: V75WLYXVL2M	BODY MODEL:	PROD. ENGINEER: JR		
CURRENT STATUS, DATE:		DATE TO MFG:	DATE MFG HOLD:	DATE FROM MFG:		

CONFIDENTIAL

 MITSUBISHI MOTOR SALES OF AMERICA, Inc.		PRODUCT QUALITY REPORT Rec No. 19383		POR No CK45 -35 -3513-3-S	DATE OF ISSUE 4/5/2006 REPORTER ID/SEQ.# 06034 / 6	
YEAR NAME OF VEHICLE / PRICE LINE 2001 MONTERO SUV 7 PASSENGER / XLS		VEHICLE IDENTIFICATION No / CHASSIS No. JA4MW31R51J		DISTRIBUTOR MMSA	ACCY ENG. N	PRIORITY B
ENGINE NO. 6G74 -3.5	TM TYPE A	MFG DATE 6/6/2000	REAR BODY (MODIFICATION) N/A	LOCATION: 06034 QUALITY MITSUBISHI, INC.		USAGE RETAIL CAR
DATE SOLD 6/29/2000		DATE / MILEAGE TROUBLE OCCURRED 4/5/2005 / 108492		STATE CO	REGION / DISTRICT 40 / D3	
VEHICLE / ENGINE SPEED N/A		ROAD CONDITION N/A	LOAD CONDITION N/A	WEATHER / TEMPERATURE N/A / N/A		MAINTENANCE GOOD
SUBJECT HBB UNIT - NOISY					FREQUENCY: FIRST FREQUENT: 1 UNITS	
1. DESCRIPTION OF SYMPTOM CHATTER NOISE IN BRAKE PEDAL LIKE THE TIME THE ACCUMALATOR WAS REPLACED UNDER RECALL					CONDITION	
DTC(S):						
2. POSSIBLE CAUSE INTERNAL FAILURE						
3. ACTION TAKEN / RESULT REPLACE ACCUMALATOR (GOODWILL), CUSTOMER PAYS LABOR						
4. ADDITIONAL COMMENTS						
REPORTER'S NAME/SIGNATURE						QUALITY MITSUBISHI, INC.
5. MANUFACTURERS RESPONSES/COMMENTS <p style="text-align: center;">REPORT HAS BEEN SUBMITTED TO MANUFACTURER FOR REVIEW</p>						
MANUFACTURER'S NAME/SIGNATURE						
MMA CONTROL #: *****				RO/CLAIM: 73638		
PART #:	PART DESCRIPTION:		PART REQ'D DATE: PART REC'D DATE:	PART SENT TO:		
IQS CATEGORY: A	IQS QUESTION: -	KMODEL: V75WLRHVL2M	BODY MODEL:	PROD. ENGINEER: JR		
CURRENT STATUS, DATE: MRSP, 4/12/2005		DATE TO MFG:	DATE MFG HOLD:	DATE FROM MFG: 4/12/2005		
CONTACT: JEFF PINAR		PHONE NUMBER: (303) 738-9700		FAX NUMBER: (303) 738-1213		

ATTACHMENT FOR QUESTION 6

◆ **NATURE CODE CHART**

◆ **CAUSE CODE CHART**

MITSUBISHI CAUSAL CODES

NATURE CODE

Only use the Nature Code "99D" when no other appropriate code exists

NATURE

0	3	P
---	---	---

CAUSE

--	--	--

WHAT HAPPENED - 1ST AND 2ND POSITION

SELECT A CODE FROM THESE TWO COLUMNS AND INSERT IN THE FIRST TWO POSITIONS.

WHEN IT HAPPENED - 3RD POSITION

SELECT A CODE FROM THIS COLUMN AND INSERT IN THE 3RD POSITION.

CODE	ENGINE	CODE	BODY-CHASSIS
00	DRIVING NOT POSSIBLE	40	WATER LEAK
01	ENGINE STALLED	41	DUST LEAK
02	ENGINE WON'T START	42	WIND LEAK
03	ENGINE WON'T IDLE	43	WIND NOISE
04	POOR ACCELERATION	44	BODY NOT LEVEL
05	ENGINE STUMBLES/HESITATES	45	POOR RIDE QUALITY
06	ENGINE KNOCKING	46	IMPROPER CLOSING
07	ENGINE RUN ON (DIESELING)	47	IMPROPER ALIGNMENT
08	ENGINE OVERHEATING	50	BATTERY DISCHARGED
09	ENGINE UNDERHEATING	51	IMPROPER INDICATION
10	HIGH FUEL CONSUMPTION	52	LIGHTING FAILURE
11	HIGH OIL CONSUMPTION	53	HORN DOES NOT SOUND
12	EXCESSIVE SMOKE	54	EXCESSIVE NOISE
14	LOW COOLANT	55	DISTORTED SOUND
16	CHECK ENGINE LAMP STAYS ON	56	POOR FIT
1D	LOOSE HOSE	57	POOR WIPING OR SPRAYING
1E	CRACKED HOSE	59	OTHER ELEC. FAILURE
	DRIVE TRAIN	60	IMPROPERLY INSTALLED
20	CLUTCH SLIPPING		ACCESSORIES
21	WILL NOT STAY IN GEAR		
22	TRANSMISSION SEIZED		
23	WILL NOT SHIFT AT ALL		
24	POOR QUALITY SHIFT	80	OTHER
25	WILL NOT SHIFT UP / DOWN	81	ABNORMAL SOUND
26	SHIFT SHOCK	82	SQUEAK OR RATTLES
27	LOOSE/DISCONNECTED SHAFT	85	VIBRATION
28	CLUTCH ACTION POOR	86	EXCESS FORCE REQUIRED
30	INEFFECTIVE OPERATION	87	WON'T STAY IN POSITION
31	GRABBING/PULLING BRAKES	88	VARYING FORCE REQUIRED
35	POOR TRACKING	90	IMPROPER RETURN
36	DRIFT TO ONE SIDE	91	POOR FINISH OR STAINED
37	OFF CENTER	92	IMPROPER CONTROL
		99	FIRE
			OTHERS NOT LISTED OR UNKNOWN
	LEAKS		
70	FUEL LEAK		
71	OIL OR GREASE LEAK		
72	WATER LEAK		
73	AIR OR VACUUM LEAK		
74	REFRIGERANT LEAK		
75	HYDRAULIC /AIR PRESS. LEAK		
7B	REFRIGERANT OVER CHARGE		
7C	LACK OF REFRIGERANT		

CODE	
A	STARTING ENGINE
B	WARMING UP
C	IDLING
D	ALL THE TIME
E	STARTING IN MOTION
F	WHILE SHIFTING TRANSMISSION
G	ACCELERATING
H	DECELERATING
J	WHILE BRAKING
L	AT LOW SPEEDS (UNDER 15 MPH)
M	AT HIGH SPEEDS (OVER 50 MPH)
P	ENGINE COLD
Q	ENGINE HOT
S	UNDER HEAVY LOADS
T	WHILE TURNING
U	IN REVERSE (BACKING UP)
V	UNDER NO LOAD (FREE REVVING)
W	IN FOUR WHEEL DRIVE
X	INVITE CLAIM ONLY
Z	OTHERS NOT LISTED
0	ASCENDING (CLIMBING HILLS)
1	DESCENDING OR COASTING
2	ON ROUGH ROADS
3	ON SLIPPERY ROADS
4	AT HIGH ALTITUDES
5	AT LOW TEMP (UNDER 32F)
6	AT HIGH TEMP (OVER 85F)
7	RAINY OR WET
8	SNOWY
9	WINDY

MITSUBISHI CAUSAL CODES

CAUSE CODE

NATURE

--	--	--

CAUSE

2	7	0
---	---	---



WHY IT HAPPENED - 4TH, 5TH, AND 6TH POSITION
 SELECT A THREE CHARACTER CODE FROM THE TWO
 COLUMNS THAT BEST DESCRIBE WHAT CAUSED THE PROBLEM.

CODE		CODE	
100	CRACKED OR BROKEN	450	IMPROPER CLEARANCE
110	DAMAGED OR TORN	460	PARTS MISSING (NOT INSTALLED)
120	BURNT OR MELTED	470	PARTS INCORRECT
130	SEIZED	480	IMPROPER INSTALLATION
140	STUCK	490	IMPROPER ADJUSTMENT
150	WORN	500	POOR WELDING
160	DEFORMED/BENT/ DISTORTED	510	POOR COATING (SEALANTS)
200	WATER LEAK	520	IMPROPER STAKING
210	WATER SOAKED	550	CAVITY, POROUS OR PINHOLE
220	OIL LEAK	560	DEFECTIVE MACHINING
230	LACK OF LUBRICANTS	570	CLOGGED
260	SHORT CIRCUIT	580	FOREIGN MATERIAL
270	OPEN CIRCUIT	590	FROZEN OR STUCK
300	RUSTED OR CORRODED	600	EXCESSIVE PLAY
310	IMPROPERLY PLATED	810	CAVITATION
320	STAINED OR DISCOLORED	820	LOW WATER LEVEL
330	FLAKED OR PEELED	830	SLIPPING
340	DETERIORATED OR FATIGUED	840	SMOLDERING
400	MISSING FASTENERS	850	OVERFLOW
410	LOOSE FASTENERS	860	DEAD BATTERY
420	MISSING CLIPS OR BANDS	870	IMPROPERLY PAINTED
430	LOOSE CLIPS OR BANDS	890	ABNORMAL SMELL
440	LOOSE, FELL OFF	990	OTHERS NOT LISTED

CODE	USE FOR PAINT + BODY REPAIRS	CODE	USE FOR ELECTRICAL REPAIRS
PAP	PRIMER COAT DEFECT	HA0	LOOSE CONNECTION AT CONNECTOR
PBP	TRIM PAINT DEFECT	HB0	CONNECTOR TERMINAL(S) BENT
PCP	FOREIGN MATERIAL	HC0	CONNECTOR BROKEN/FRACTURED
PDP	PAINT RUNS	HD0	CONNECTOR TERMINAL BROKEN/FRACTURED
PEP	SCRATCHED	HE0	HARNESS NOT CLIPPED OR STRAPPED
PGP	DISCOLORATION	HF0	TERMINAL PUSHED OUT FROM CONNECTOR
PHP	FADING	HG0	CONNECTOR TERMINAL SPREAD APART
PJP	UNEVEN FINISH	HI0	CONNECTOR TERMINAL POORLY CRIMPED
PKP	BLISTERED	HJ0	WIRES CUT/BROKEN BY SHARP EDGE
PMP	RUST SPOT	HK0	WIRES CUT/BROKEN BY SCREW OR BOLT
PNP	RUST PERFORATION	HL0	WIRES CROSSED IN CONNECTOR
PPP	RUST AT SEAMS OR JOINTS	HM0	WIRES BURNED
PGP	RUST CAUSED BY MOLDINGS	HN0	WIRE PINCHED
PRP	COLOR MISMATCHING	HP0	WIRE TERMINAL(S) CORRODED
PSP	ORANGE PEEL	HQ0	BROKEN SPLICE IN HARNESS
PTP	PEELING		
PXP	OTHER PAINT DEFECTS		3 RD CHARACTER OF ELECT. CAUSAL CODES IS ZERO

ATTACHMENT FOR QUESTION 7

- ◆ **SR-01-008**
- ◆ **SR-01-008REV**
- ◆ **SR-01-008REVII**
- ◆ **ATIN-01-SR-010**

SAFETY RECALL BULLETIN

SUBJECT: HYDRAULIC BRAKE BOOSTER ACCUMULATOR — SAFETY RECALL CAMPAIGN			No: SR-01-008
			DATE: September, 2001
			MODEL: See below
CIRCULATE TO:	<input checked="" type="checkbox"/> GENERAL MANAGER	<input checked="" type="checkbox"/> PARTS MANAGER	<input checked="" type="checkbox"/> TECHNICIAN
<input checked="" type="checkbox"/> SERVICE ADVISOR	<input checked="" type="checkbox"/> SERVICE MANAGER	<input checked="" type="checkbox"/> WARRANTY PROCESSOR	<input checked="" type="checkbox"/> SALES MANAGER

PURPOSE

The hydraulic brake booster (HBB) accumulator on affected vehicles may have been manufactured improperly, which over a period of time may result in leakage of the pressurized nitrogen gas from inside the accumulator. The loss of this gas pressure may result in an abnormal noise from the left side of the dash panel when the brakes are applied, and possibly a delayed first time brake boost assist after the vehicle has been parked for a period of time.

Replace the HBB accumulator with the new, improved parts listed in the PARTS INFORMATION section of this bulletin.

AFFECTED VEHICLES

2001-2002 Montero models produced before 6/20/01.

CUSTOMER NOTIFICATION

A letter will be sent to all owners of affected vehicles, telling them to bring their vehicle to their Mitsubishi Motors dealer to replace the hydraulic brake booster accumulator. A copy of the customer notification letter appears later in this bulletin.

REQUIRED OPERATIONS

Before starting this procedure, **CHECK ON THE WARRANTY SUPERSCREEN** to verify that the vehicle is an affected VIN for this campaign and that this campaign procedure has not already been completed.

1. Inspect the color of the nut at the top of the hydraulic brake booster accumulator.
 - a. If the nut is painted pink, **STOP**. The improved accumulator has already been installed. Do not continue with this campaign procedure.
 - b. If the nut is **not** painted pink, continue with Step 2 to replace the hydraulic brake booster accumulator.
2. With the ignition turned to the LOCK position, depress the brake pedal repeatedly (up to 40 times) until the pedal becomes hard (high pedal effort). This will relieve the pressure in the accumulator.

CAUTION

If pressure is left in the power assist system, brake fluid will spill when removing the accumulator.

Continued

FILE UNDER:	Safety Recall Bulletins in the Dealer Service Information Binder	(2302)
--------------------	---	---------------

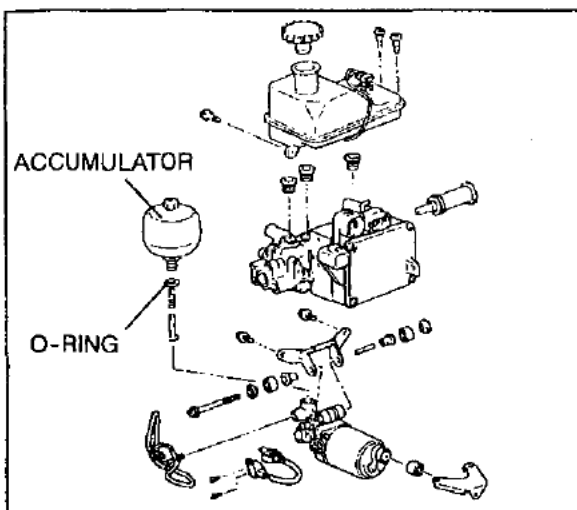

3. Use a 21 mm socket to remove the accumulator. Place a cloth under the accumulator to prevent brake fluid spillage.

Remove the accumulator **vertically**, to prevent metal shavings from accidentally entering the HBB. Remove the O-ring.

CAUTION

DO NOT USE AIR TOOLS TO REMOVE OR INSTALL THE ACCUMULATOR.

Use of air tools will likely result in shearing the nut from the top of the accumulator.

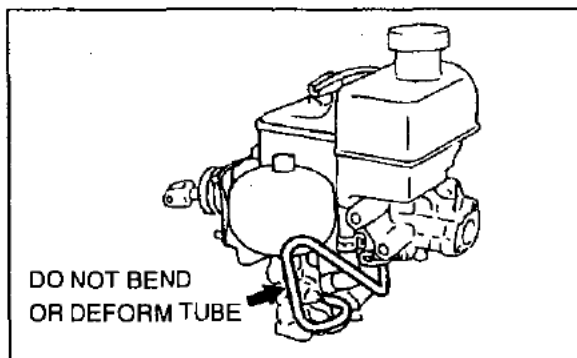

CAUTION

USE CARE TO PREVENT BENDING OR DEFORMING THE TUBE.

WARNING

THE NITROGEN GAS INSIDE THE ORIGINAL ACCUMULATOR MUST BE DISCHARGED BEFORE DISPOSAL. SEE STEP 7.

4. Install the new accumulator provided in the kit (listed in the PARTS INFORMATION section of this bulletin):
 - a. Be sure to use the new O-ring (from the kit) at the bottom of the threaded area of the accumulator.
 - b. Be sure to install the accumulator **vertically**. **DO NOT USE AIR TOOLS TO INSTALL THE NEW ACCUMULATOR.**
 - c. Tighten to 53.9 Nm (40 ft/lbs).
5. Bleed air from the HBB system as follows:
 - a. Turn the ignition on. The HBB pump motor should come on automatically.

Continued

- b. When the HBB pump motor stops, turn off the ignition. Depress the brake pedal up to 40 times, until the pedal becomes hard (high pedal effort). Pump the brake pedal slowly, about one stroke per second.
 - c. Repeat Steps 5a. and 5b. **four times.**
 - d. Replenish the brake fluid in the reservoir tank until it reaches the MAX level.
6. Check for any brake fluid leakage around the accumulator.
 7. Discharge and dispose of the old accumulator as follows. **Wear safety glasses during this procedure.**

⚠ WARNING

THE NITROGEN GAS INSIDE THE ACCUMULATOR MUST BE DISCHARGED BEFORE DISPOSAL.

- a. Secure the accumulator in a vise.
- b. Use a punch at the location shown to create a small dimple for drilling.

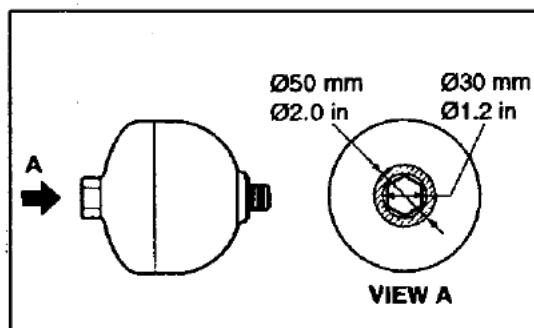

- c. Using a drill with a 4 mm drill bit, slowly drill a hole in the accumulator to discharge the nitrogen gas. The accumulator will not burst during drilling.

NOTE: You will hear the nitrogen gas discharge. The discharged nitrogen gas is colorless, odorless, and harmless.

- d. Dispose of the accumulator in compliance with Federal, state, and local laws.

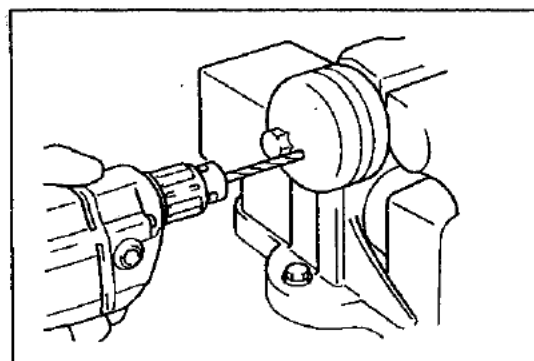

PARTS INFORMATION

A small supply of HBB accumulator kits will be shipped to each dealer automatically. Orders for additional parts can be placed through the normal parts system.

Part No.	Description	Quantity Required
MR977223	HBB Accumulator Kit (contains accumulator and O-ring)	1
MZ311987	Mitsubishi Genuine Brake Fluid	As needed

Continued

WARRANTY INFORMATION

Claims for this campaign must be entered as Recall type "C" claims on your Diamond Network Service Menu. Sample claim screens are shown on the next pages.

Hydraulic Brake Booster Accumulator - Inspection Only

Campaign Labor Operation: C0109WXX Time allowance: 0.2 hrs.

Hydraulic Brake Booster Accumulator - Inspection and Replacement

Campaign Labor Operation: C0109WXX Time allowance: 0.5 hrs.

Allowable Parts: Refer to the PARTS INFORMATION section of this bulletin.

Mitsubishi Motor Sales of America, Inc.

SERVICE CAMPAIGN CLAIM SAMPLE - LABOR OPERATION = C0109WXX

ADVANCED DIAMOND NET SCREENS FOR RECALL CLAIMS

SERVICE MENU - SELECT RECALL CLAIM (C)

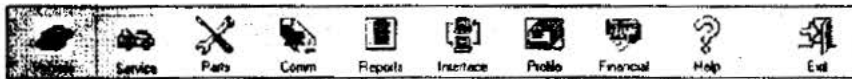

Service Menu

Data Entry

- PDI Claim (P)
- Warranty Claims (W)
- Special Claims (S)
- Recall Claim (C)**
- Opt. Equipment Reg
- Corrections/PWA
- Appeal Claims

MMSA Online

- MMSA Service Menu
- Comments Entry

Prepare to Comm
Reports
MMSA Acknowledge
Close

ENTER THIS CLAIM AS RECALL CLAIM TYPE 'C' ONLY.

RECALL CAMPAIGN CUSTOMER / REPAIR INFO SCREEN

Advanced Diamond Network System v1.03

2008
Claim Type: C
PWA: DSH
Mileage: 17077

Repair Info

City: Chicago State: IL

Phone: 043211

Parts & Labor Detail Info

Claim Totals	
Labor	0.00
Parts (w/mark-up)	0.00
Sublet	0.00
Sub-Total	0.00
Tax	0.00
Total Amount	0.00

Click on "Parts & Labor Detail Info" tab to get the detail screen

Save
Cancel
Print
Summary

FILL IN ALL OF THE REQUIRED OWNER INFORMATION ITEMS INCLUDING PHONE NUMBER.

Be sure the vehicle is actually involved in this campaign. Check the Super Screen to be sure.

RECALL CAMPAIGN CLAIM PARTS AND LABOR DETAIL INFO SCREEN:

- **USE C0109WXX TO INSPECT THE HYDRAULIC BRAKE ACCUMULATOR ASSEMBLY.**

INSPECTION ONLY SAMPLE CLAIM

Recall Claim (C) Entry - Advanced Diamond Network System v1.03

Home Service Parts Comm Rep Interface PWA Financial Help Exit

Year: 2008 Class: C Repair: PWA: DSM Reasons: Mileage: 17077
VIN: JA

Customer / Repair Info Parts & Labor Detail Info

INSPECT ONLY - HYDRAULIC BRAKE ACCUMULATOR

Verify the vehicle is actually involved in this campaign by checking the Superscreen.

Line	Part Number	Qty	Cost	Sub	Operation	Qty	Lbr Hours	Amount	Delete
A		1			C0109WXX	1	0.2		

No parts will be needed for an inspection only claim.

Enter C0109WXX

Enter a qty of 1 x 0.2 hrs. labor x your dealership's warranty labor rate.

Lines: 1 Total Parts: Total Labor: Pg 1 of 1 Pg Up Pg Dn DEL EN

Save New Print Delete First Home Send Exit

- USE C0109WXX TO REPLACE THE HYDRAULIC BRAKE ACCUMULATOR ASSEMBLY.

INSPECT AND REPLACE SAMPLE CLAIM

Recall Claim (C) Entry - Advanced Diamond Network System v1.03

Claim Number: Claim Type:
 Repair: PWA: DSM: SEQ: Reasons: Mileage:
 VIN:

INSPECT AND REPLACE IF NEEDED - HYDRAULIC BRAKE ACCUMULATOR

Verify the vehicle is actually involved in this campaign by checking the Superscreen.

Line	Part Number	Qty	Cost	Sub	Operation	Qty	Lbr Hours	Amount	Delete
A	<input type="text"/>	<input type="text"/>	<input type="text"/>		C0109WXX	1	0.5	<input type="text"/>	<input type="text"/>

Enter C0109WXX

Enter a qty of 1 x 0.5 hrs. labor x your dealership's warranty labor rate.

This kit is the only part that is required.

"Top off" brake fluid if needed may be claimed using or \$1.00.



6400 KATELLA AVENUE
CYPRESS, CALIFORNIA 90630-5208
(888) MITSU2001

AFFECTED VEHICLES
MODELS: 2001-2002 Montero

October, 2001

RE: IMPORTANT SAFETY RECALL NOTIFICATION: SR-01-008

Dear Mitsubishi Owner:

This notice is sent to you in accordance with the requirements of the National Traffic and Motor Vehicle Safety Act. Mitsubishi Motor Sales of America, Inc. has determined that a defect which relates to vehicle safety exists in certain 2001-2002 Montero vehicles produced before June 20, 2001.

What is the safety issue? The hydraulic brake booster accumulator may leak pressurized nitrogen gas. This could cause an abnormal noise when the brakes are applied, and a delay in brake response. The dealer will assist after the vehicle has been parked for a period of time, which could result in a crash.

What you should do: Please call your Mitsubishi dealer immediately to schedule a repair date. Check whether parts are in stock for Safety Recall 01-008. If your dealer does not have parts in stock, the parts should be ordered before scheduling a repair date. When you bring your vehicle in, show the dealer this letter. (If you misplace this letter, the dealer will still make the repair, free of charge.)

What your dealer will do: The dealer will replace the hydraulic brake booster accumulator on your vehicle free of charge.

How long will it take? The time needed for the repair is about 30 minutes. However, your dealer may need your vehicle for a longer period of time to provide scheduling issues.

Have you changed address or sold the vehicle? If you have changed your address or sold the vehicle, please fill out the enclosed postcard and mail it to:

If you have any trouble getting your vehicle repaired promptly and at no charge, please inform us by calling:

Mitsubishi Customer Relations Department
(888) MITSU-2002 (888-648-7820)
(Central Standard Time) Monday - Saturday 7 a.m. to 10 p.m.

If after contacting Mitsubishi Customer Relations, you still have a problem having your vehicle repaired promptly and without charge, write to the Administrator, National Highway Traffic Safety Administration, 400 Seventh Street S.W., Washington, D.C. 20590, or call the Auto Safety Hotline toll-free (888) 327-4236.

Mitsubishi is committed to making your safety our first concern and we sincerely regret the inconvenience to you caused by this recall.

Sincerely,

SR-01-008
C0109WXX

Richard Donnelson
Director, Customer Relations

[Notice to Lessors: If you are a lessor of five or more leased vehicles as of the date of this letter, you have an obligation under federal law (49 CFR Part 577) to provide the lessee of the above referenced vehicle with a copy of this letter by first class mail within ten days of receipt. Also, you must maintain a record which identifies the lessee to whom you sent a copy of this letter, the date you sent it, and the vehicle identification number (VIN) of the subject vehicle.]

SUBJECT: HYDRAULIC BRAKE BOOSTER ACCUMULATOR — SAFETY RECALL CAMPAIGN			No: SR-01-008REV
			DATE: October, 2001
			MODEL: See below
CIRCULATE TO:	<input checked="" type="checkbox"/> GENERAL MANAGER	<input checked="" type="checkbox"/> PARTS MANAGER	<input checked="" type="checkbox"/> TECHNICIAN
<input checked="" type="checkbox"/> SERVICE ADVISOR	<input checked="" type="checkbox"/> SERVICE MANAGER	<input checked="" type="checkbox"/> WARRANTY PROCESSOR	<input checked="" type="checkbox"/> SALES MANAGER

This bulletin supercedes SR-01-008, issued September, 2001, to correct the replacement accumulator part number in the sample warranty screen on page 7, marked by ►.

PURPOSE

The hydraulic brake booster (HBB) accumulator on affected vehicles may have been manufactured improperly, which over a period of time may result in leakage of the pressurized nitrogen gas from inside the accumulator. The loss of this gas pressure may result in an abnormal noise from the left side of the dash panel when the brakes are applied, and possibly a delayed first time brake boost assist after the vehicle has been parked for a period of time.

Replace the HBB accumulator with the new, improved parts listed in the PARTS INFORMATION section of this bulletin.

AFFECTED VEHICLES

2001-2002 Montero models produced before 6/20/01.

CUSTOMER NOTIFICATION

A letter will be sent to all owners of affected vehicles, telling them to bring their vehicle to their Mitsubishi Motors dealer to replace the hydraulic brake booster accumulator. A copy of the customer notification letter appears later in this bulletin.

REQUIRED OPERATIONS

Before starting this procedure, **CHECK ON THE WARRANTY SUPERSCREEN** to verify that the vehicle is an affected VIN for this campaign and that this campaign procedure has not already been completed.

1. Inspect the color of the nut at the top of the hydraulic brake booster accumulator.
 - a. If the nut is painted pink, **STOP**. The improved accumulator has already been installed. Do not continue with this campaign procedure.
 - b. If the nut is **not** painted pink, continue with Step 2 to replace the hydraulic brake booster accumulator.
2. With the ignition turned to the LOCK position, depress the brake pedal repeatedly (up to 40 times) until the pedal becomes hard (high pedal effort). This will relieve the pressure in the accumulator.

CAUTION

If pressure is left in the power assist system, brake fluid will spill when removing the accumulator.

Continued

FILE UNDER:	Safety Recall Bulletins in the Dealer Service Information Binder	(2353)
-------------	---	---------------

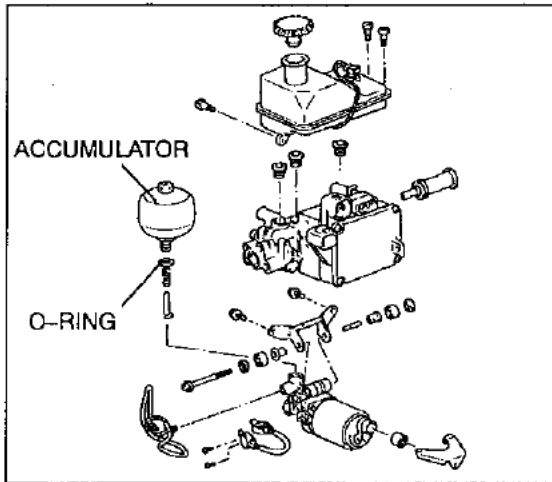

3. Use a 21 mm socket to remove the accumulator. Place a cloth under the accumulator to prevent brake fluid spillage.

Remove the accumulator **vertically**, to prevent metal shavings from accidentally entering the HBB. Remove the O-ring.

CAUTION

DO NOT USE AIR TOOLS TO REMOVE OR INSTALL THE ACCUMULATOR.

Use of air tools will likely result in shearing the nut from the top of the accumulator.

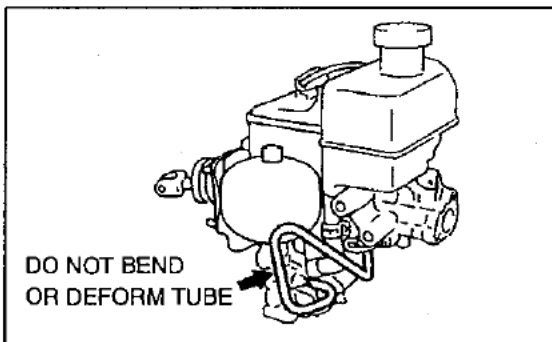

CAUTION

USE CARE TO PREVENT BENDING OR DEFORMING THE TUBE.

WARNING THE NITROGEN GAS INSIDE THE ORIGINAL ACCUMULATOR MUST BE DISCHARGED BEFORE DISPOSAL. SEE STEP 7.

4. Install the new accumulator provided in the kit (listed in the PARTS INFORMATION section of this bulletin):
 - a. Be sure to use the new O-ring (from the kit) at the bottom of the threaded area of the accumulator.
 - b. Be sure to install the accumulator **vertically**. **DO NOT USE AIR TOOLS TO INSTALL THE NEW ACCUMULATOR.**
 - c. Tighten to 53.9 Nm (40 ft/lbs).
5. Bleed air from the HBB system as follows:
 - a. Turn the ignition on. The HBB pump motor should come on automatically.

Continued

- b. When the HBB pump motor stops, turn off the ignition. Depress the brake pedal up to 40 times, until the pedal becomes hard (high pedal effort). Pump the brake pedal slowly, about one stroke per second.
 - c. Repeat Steps 5a. and 5b. ***four times***.
 - d. Replenish the brake fluid in the reservoir tank until it reaches the MAX level.
6. Check for any brake fluid leakage around the accumulator.
 7. Discharge and dispose of the old accumulator as follows. **Wear safety glasses during this procedure.**

⚠ WARNING

THE NITROGEN GAS INSIDE THE ACCUMULATOR MUST BE DISCHARGED BEFORE DISPOSAL.

- a. Secure the accumulator in a vise.
- b. Use a punch at the location shown to create a small dimple for drilling.

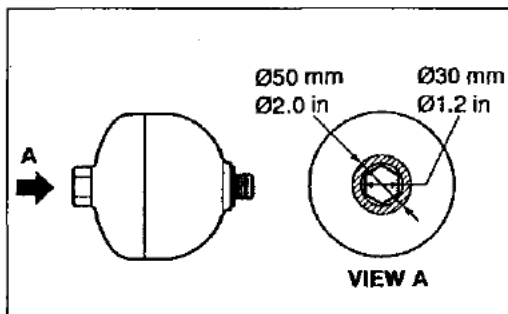

- c. Using a drill with a 4 mm drill bit, slowly drill a hole in the accumulator to discharge the nitrogen gas. The accumulator will not burst during drilling.

NOTE: You will hear the nitrogen gas discharge. The discharged nitrogen gas is colorless, odorless, and harmless.

- d. Dispose of the accumulator in compliance with Federal, state, and local laws.

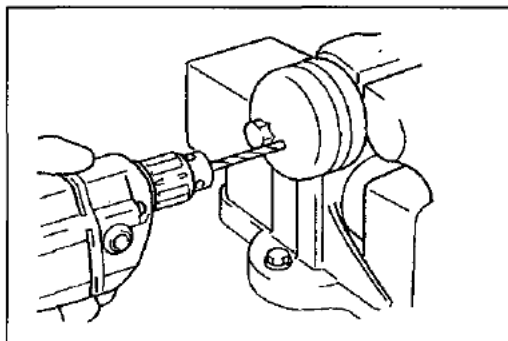

PARTS INFORMATION

A small supply of HBB accumulator kits will be shipped to each dealer automatically. Orders for additional parts can be placed through the normal parts system.

Part No.	Description	Quantity Required
MR977223	HBB Accumulator Kit (contains accumulator and O-ring)	1
MZ311987	Mitsubishi Genuine Brake Fluid	As needed

Continued

WARRANTY INFORMATION

Claims for this campaign must be entered as Recall type "C" claims on your Diamond Network Service Menu. Sample claim screens are shown on the next pages.

Hydraulic Brake Booster Accumulator – Inspection Only

Campaign Labor Operation: C0109WXX Time allowance: 0.2 hrs.

Hydraulic Brake Booster Accumulator – Inspection and Replacement

Campaign Labor Operation: C0109WXX Time allowance: 0.5 hrs.

Allowable Parts: Refer to the PARTS INFORMATION section of this bulletin.

Mitsubishi Motor Sales of America, Inc.

SERVICE CAMPAIGN CLAIM SAMPLE - LABOR OPERATION = C0109WXX

ADVANCED DIAMOND NET SCREENS FOR RECALL CLAIMS

SERVICE MENU - SELECT RECALL CLAIM (C)

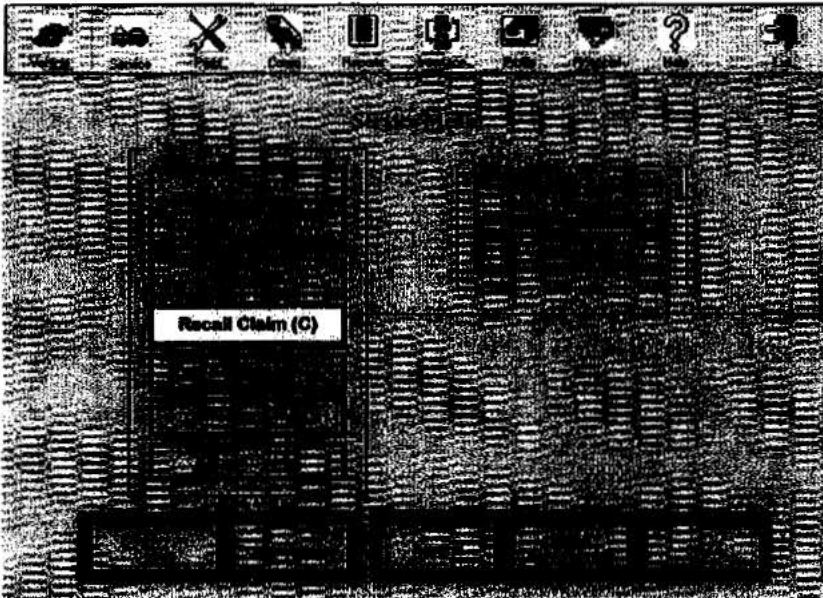

ENTER THIS CLAIM AS RECALL CLAIM TYPE 'C' ONLY.

RECALL CAMPAIGN CUSTOMER / REPAIR INFO SCREEN

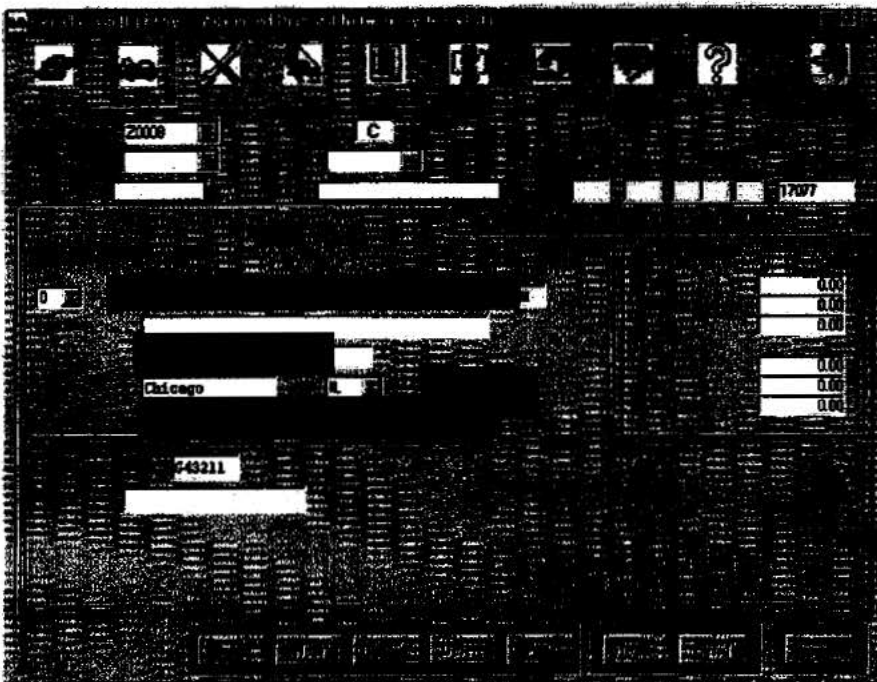

FILL IN ALL OF THE REQUIRED OWNER INFORMATION ITEMS INCLUDING PHONE NUMBER.

Be sure the vehicle is actually involved in this campaign. Check the Super Screen to be sure.

RECALL CAMPAIGN CLAIM PARTS AND LABOR DETAIL INFO SCREEN:

- **USE C0109WXX TO INSPECT THE HYDRAULIC BRAKE ACCUMULATOR ASSEMBLY.**

INSPECTION ONLY SAMPLE CLAIM

Recall Claim (C) Entry Advanced Diamond Network System v1.03

20008 C JA... 17077

INSPECT ONLY - HYDRAULIC BRAKE ACCUMULATOR

Verify the vehicle is actually involved in this campaign by checking the Superscreen.

Line	Part Number	Qty	Cost	Sub	Operation	Qty	Lbr Hours	Amount	Delete
A					C0109WXX	1	0.2		

No parts will be needed for an inspection only claim.

Enter C0109WXX

Enter a qty of 1 x 0.2 hrs. labor x your dealership's warranty labor rate.

1

PREV PAGES PAGES

Ready Done

- **USE C0109WXX TO REPLACE THE HYDRAULIC BRAKE ACCUMULATOR ASSEMBLY.**

INSPECT AND REPLACE SAMPLE CLAIM

Recall Claim (C) Entry - Advanced Diamond Network System v1.03

2008 C JA... 17077

INSPECT AND REPLACE IF NEEDED - HYDRAULIC BRAKE ACCUMULATOR

Verify the vehicle is actually involved in this campaign by checking the Superscreen.

Line	Part Number	Qty	Cost	Sub	Operation	Qty	Lbr Hours	Amount	Delete
A					C0109WXX	1	0.5		

Enter C0109WXX

Enter a qty of 1 x 0.5 hrs. labor x your dealership's warranty labor rate.

This kit is the only part that is required.

"Top off" brake fluid if needed may be claimed using [redacted] for \$1.00.

1

Print

Ready Done



8400 KATELLA AVENUE
CYPRESS, CALIFORNIA 90630-5208
(888) MITSU2001

AFFECTED VEHICLES

MODELS: 2001-2002 Montero

October, 2001

RE: IMPORTANT SAFETY RECALL NOTIFICATION: SR-01-008

Dear Mitsubishi Owner:

This notice is sent to you in accordance with the requirements of the National Traffic and Motor Vehicle Safety Act. Mitsubishi Motor Sales of America, Inc. has determined that a defect which relates to vehicle safety exists in certain 2001-2002 Montero vehicles produced before June 20, 2001.

What is the safety issue? The hydraulic brake booster accumulator may leak pressurized nitrogen gas. This could cause an abnormal noise when the brakes are applied, and a delay in brake pedal assist after the vehicle has been parked for a period of time, which could result in a crash.

What you should do: Please call your Mitsubishi dealer immediately to schedule a repair date. Check whether parts are in stock for Safety Recall 01-008. If your dealer does not have parts in stock, they should be ordered before scheduling a repair date. When bringing your vehicle in, show this dealer this letter. (If you misplace this letter, the dealer will still make the repair, free of charge.)

What your dealer will do: The dealer will replace the hydraulic brake booster accumulator on your vehicle free of charge.

How long will it take? The time needed for the repair is about 30 minutes. However, your dealer may need your vehicle for a longer period of time due to vehicle scheduling issues.

Have you changed address or sold the vehicle? If you have changed your address or sold the vehicle, please fill out the enclosed postcard and mail it to:

If you have any trouble getting your vehicle repaired promptly and at no charge, please inform us by calling:

Mitsubishi Customer Relations Department
(888) MITSU-2002 (888-648-7820)
(Central Standard Time) Monday – Saturday 7 a.m. to 10 p.m.

If after contacting Mitsubishi Customer Relations, you still have a problem having your vehicle repaired promptly and without charge, write to the Administrator, National Highway Traffic Safety Administration, 400 Seventh Street S.W., Washington, D.C. 20590, or call the Auto Safety Hotline toll-free (888) 327-4236.

Mitsubishi is committed to making your safety our first concern and we sincerely regret the inconvenience to you caused by this recall.

Sincerely,

SR-01-008
C0109WXX

Richard Donnelson
Director, Customer Relations

[Notice to Lessors: If you are a lessor of five or more leased vehicles as of the date of this letter, you have an obligation under federal law (49 CFR Part 577) to provide the lessee of the above referenced vehicle with a copy of this letter by first class mail within ten days of receipt. Also, you must maintain a record which identifies the lessee to whom you sent a copy of this letter, the date you sent it, and the vehicle identification number (VIN) of the subject vehicle.]

SUBJECT: HYDRAULIC BRAKE BOOSTER ACCUMULATOR — SAFETY RECALL CAMPAIGN		No: SR-01-008REVII
		DATE: October, 2001
		MODEL: See below
CIRCULATE TO:	<input checked="" type="checkbox"/> GENERAL MANAGER	<input checked="" type="checkbox"/> PARTS MANAGER
	<input checked="" type="checkbox"/> SERVICE ADVISOR	<input checked="" type="checkbox"/> TECHNICIAN
	<input checked="" type="checkbox"/> SERVICE MANAGER	<input checked="" type="checkbox"/> WARRANTY PROCESSOR
		<input checked="" type="checkbox"/> SALES MANAGER

This bulletin supercedes SR-01-008REV, which should be discarded. This bulletin contains revised accumulator discharge and disposal procedures. The new procedures are marked by ►.

PURPOSE

The hydraulic brake booster (HBB) accumulator on affected vehicles may have been manufactured improperly, which over a period of time may result in leakage of the pressurized nitrogen gas from inside the accumulator. The loss of this gas pressure may result in an abnormal noise from the left side of the dash panel when the brakes are applied, and possibly a delayed first time brake boost assist after the vehicle has been parked for a period of time.

Replace the HBB accumulator with the new, improved parts listed in the PARTS INFORMATION section of this bulletin.

AFFECTED VEHICLES

2001–2002 Montero models produced before 6/20/01.

CUSTOMER NOTIFICATION

A letter will be sent to all owners of affected vehicles, telling them to bring their vehicle to their Mitsubishi Motors dealer to replace the hydraulic brake booster accumulator. A copy of the customer notification letter appears later in this bulletin.

REQUIRED OPERATIONS

Before starting this procedure, **CHECK ON THE WARRANTY SUPERSCREEN** to verify that the vehicle is an affected VIN for this campaign and that this campaign procedure has not already been completed.

1. Inspect the color of the nut at the top of the hydraulic brake booster accumulator.
 - a. If the nut is painted pink, **STOP**. The improved accumulator has already been installed. Do not continue with this campaign procedure.
 - b. If the nut is **not** painted pink, continue with Step 2 to replace the hydraulic brake booster accumulator.
2. With the ignition turned to the LOCK position, depress the brake pedal repeatedly (up to 40 times) until the pedal becomes hard (high pedal effort). This will relieve the pressure in the accumulator.

CAUTION

If pressure is left in the power assist system, brake fluid will spill when removing the accumulator.

Continued

FILE UNDER:	Safety Recall Bulletins in the Dealer Service Information Binder	(2371)
-------------	---	---------------

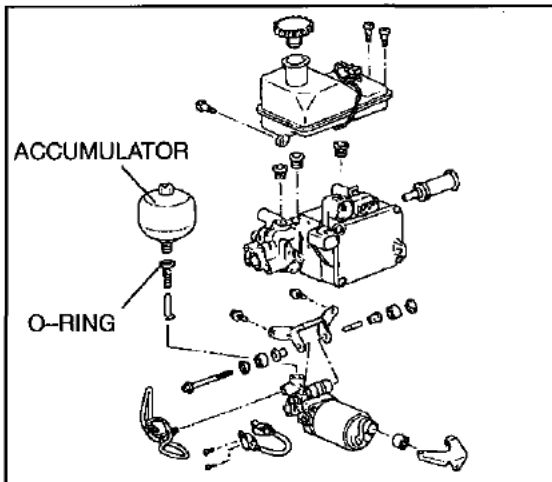

3. Use a 21 mm socket to remove the accumulator. Place a cloth under the accumulator to prevent brake fluid spillage.

Remove the accumulator **vertically**, to prevent metal shavings from accidentally entering the HBB. Remove the O-ring.

⚠ CAUTION

DO NOT USE AIR TOOLS TO REMOVE OR INSTALL THE ACCUMULATOR.

Use of air tools will likely result in shearing the nut from the top of the accumulator.

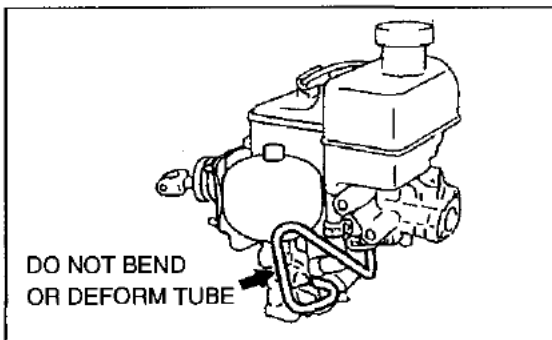

⚠ CAUTION

USE CARE TO PREVENT BENDING OR DEFORMING THE TUBE.

⚠ WARNING THE NITROGEN GAS INSIDE THE ORIGINAL ACCUMULATOR MUST BE DISCHARGED BEFORE DISPOSAL. SEE STEP 7.

4. Install the new accumulator provided in the kit (listed in the PARTS INFORMATION section of this bulletin):
 - a. Be sure to use the new O-ring (from the kit) at the bottom of the threaded area of the accumulator.
 - b. Be sure to install the accumulator **vertically**. **DO NOT USE AIR TOOLS TO INSTALL THE NEW ACCUMULATOR.**
 - c. Tighten to 53.9 Nm (40 ft/lbs).
5. Bleed air from the HBB system as follows:
 - a. Turn the ignition on. The HBB pump motor should come on automatically.

Continued

- b. When the HBB pump motor stops, turn off the ignition. Depress the brake pedal up to 40 times, until the pedal becomes hard (high pedal effort). Pump the brake pedal slowly, about one stroke per second.
 - c. Repeat Steps 5a. and 5b. ***four times***.
 - d. Replenish the brake fluid in the reservoir tank until it reaches the MAX level.
6. Check for any brake fluid leakage around the accumulator.
7. Discharge and dispose of the old accumulator as follows:

⚠ WARNING

THE NITROGEN GAS INSIDE THE ACCUMULATOR MUST BE DISCHARGED BEFORE DISPOSAL.

WEAR SAFETY GLASSES DURING THIS PROCEDURE.

- ▶ a. Discharge the accumulator in an area **away from all vehicles**, to prevent any possible damage from brake fluid, rubber and plastic particles that may spray out.

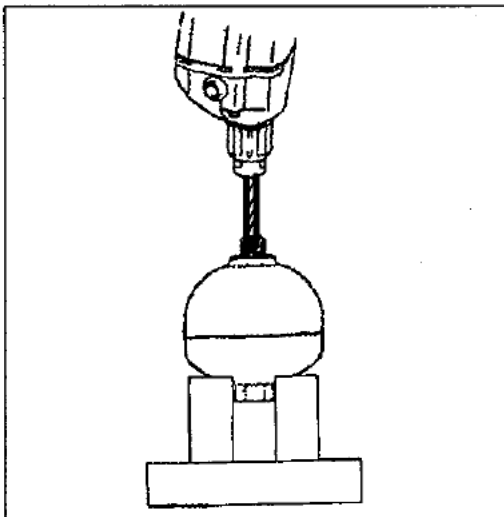

- ▶ b. Secure the accumulator in a vise, with the threaded nipple pointing upward.
- ▶ c. Insert a 4mm drill bit in the hole in the nipple. Then **SLOWLY drill through the hole in the nipple**. You will hear a hissing sound as the nitrogen gas is released. The gas is odorless, colorless, and harmless.
NOTE: Small pieces of plastic and/or rubber may spray out from the drilled hole.
- ▶ d. Scratch a large X on the accumulator near the nipple, to identify that it has been discharged.
- ▶ e. If any brake fluid remains in the accumulator, drain the fluid out.
- f. Dispose of the accumulator in compliance with Federal, state, and local laws.

PARTS INFORMATION

A small supply of HBB accumulator kits will be shipped to each dealer automatically. Orders for additional parts can be placed through the normal parts system.

Part No.	Description	Quantity Required
MR977223	HBB Accumulator Kit (contains accumulator and O-ring)	1
MZ311987	Mitsubishi Genuine Brake Fluid	As needed

Continued

WARRANTY INFORMATION

Claims for this campaign must be entered as Recall type "C" claims on your Diamond Network Service Menu. Sample claim screens are shown on the next pages.

Hydraulic Brake Booster Accumulator – Inspection Only

Campaign Labor Operation: C0109WXX Time allowance: 0.2 hrs.

Hydraulic Brake Booster Accumulator – Inspection and Replacement

Campaign Labor Operation: C0109WXX Time allowance: 0.5 hrs.

Allowable Parts: Refer to the PARTS INFORMATION section of this bulletin.

Mitsubishi Motor Sales of America, Inc.

SERVICE CAMPAIGN CLAIM SAMPLE - LABOR OPERATION = C0109WXX

ADVANCED DIAMOND NET SCREENS FOR RECALL CLAIMS

SERVICE MENU - SELECT RECALL CLAIM (C)

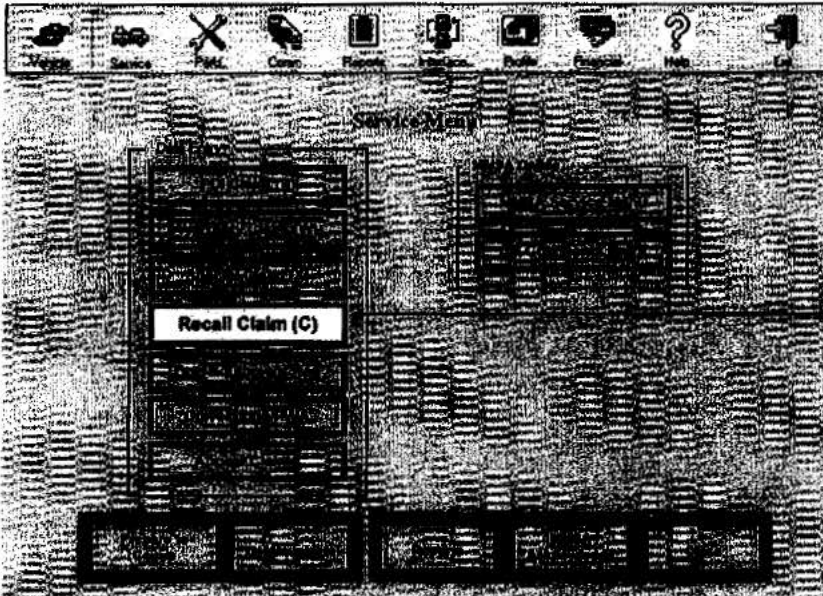

**ENTER THIS CLAIM AS
RECALL CLAIM TYPE 'C'
ONLY.**

RECALL CAMPAIGN CUSTOMER / REPAIR INFO SCREEN

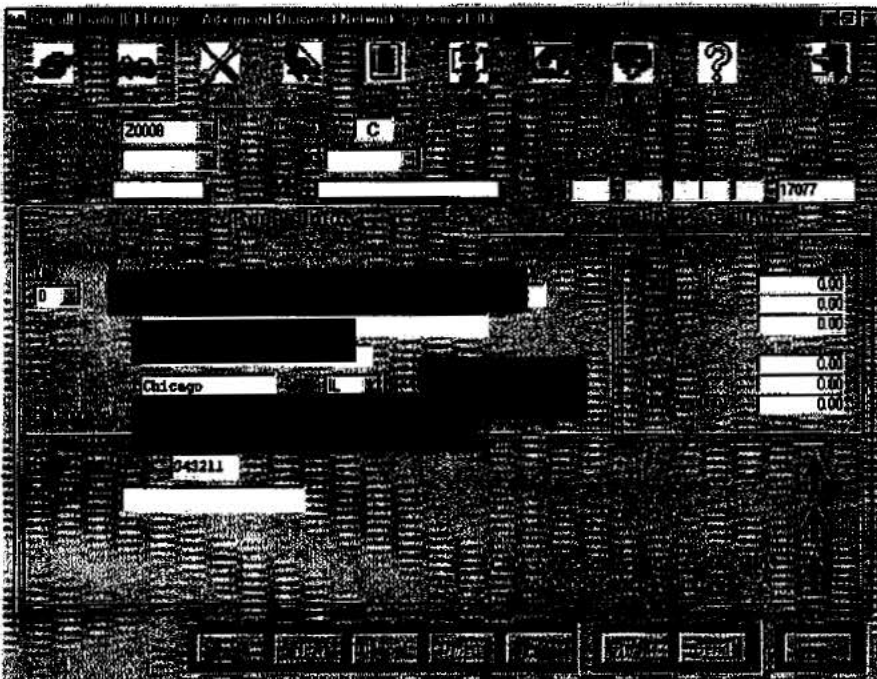

**FILL IN ALL OF THE REQUIRED
OWNER INFORMATION ITEMS
INCLUDING PHONE NUMBER.**

*Be sure the vehicle is actually
involved in this campaign.
Check the Super Screen to be
sure.*

RECALL CAMPAIGN CLAIM PARTS AND LABOR DETAIL INFO SCREEN:

- **USE C0109WXX TO INSPECT THE HYDRAULIC BRAKE ACCUMULATOR ASSEMBLY.**

INSPECTION ONLY SAMPLE CLAIM

Advanced Diamond Network System v1.00

INSPECT ONLY -
HYDRAULIC BRAKE ACCUMULATOR

Verify the vehicle is actually involved in this campaign by checking the SuperScreen.

Line	Part Number	Qty	Unit	Sub	Operation	Upr	Upr Hours	Amount	Detail
A		1	0.2		C0109WXX				

No parts will be needed for an inspection only claim.

Enter C0109WXX

Enter a qty of 1 x 0.2 hrs. labor x your dealership's warranty labor rate.

- **USE C0109WXX TO REPLACE THE HYDRAULIC BRAKE ACCUMULATOR ASSEMBLY.**

INSPECT AND REPLACE SAMPLE CLAIM

Recall Claim (C) Entry - Advanced Diamond Network System v1.03

2008 C JA... 17077

INSPECT AND REPLACE IF NEEDED - HYDRAULIC BRAKE ACCUMULATOR

Verify the vehicle is actually involved in this campaign by checking the Superscreen.

Line	Part Number	Qty	Cost	Sub	Operation	Qty	Lbr Hours	Amount	Delete
A					C0109WXX	1	0.5		

MR977223
This kit is the only part that is required.
"Top off" brake fluid if needed may be claimed using MZ311987 for \$1.00.

Enter C0109WXX

Enter a qty of 1 x 0.5 hrs. labor x your dealership's warranty labor rate.

1

Ready



6400 KATELLA AVENUE
CYPRESS, CALIFORNIA 90630-5208
(888) MITSU2001

AFFECTED VEHICLES
MODELS: 2001-2002 Montero

October, 2001

RE: IMPORTANT SAFETY RECALL NOTIFICATION: SR-01-008

Dear Mitsubishi Owner:

This notice is sent to you in accordance with the requirements of the National Traffic and Motor Vehicle Safety Act. Mitsubishi Motor Sales of America, Inc. has determined that a defect which relates to vehicle safety exists in certain 2001-2002 Montero vehicles produced before June 20, 2001.

What is the safety issue? The hydraulic brake booster accumulator may leak pressurized nitrogen gas which could cause an abnormal noise when the brakes are applied, and a delay in brake response after the vehicle has been parked for a period of time, which could result in a crash.

What you should do: Please call your Mitsubishi dealer immediately to schedule a repair date. Check whether parts are in stock for Safety Recall 01-008. If your dealer does not have parts in stock, they will be ordered before scheduling a repair date. When bringing your vehicle in, show this dealer this letter. (If you misplace this letter, the dealer will still make the repair, free of charge.)

What your dealer will do: The dealer will replace the hydraulic brake booster accumulator on your vehicle free of charge.

How long will it take? The time needed for the repair is about 90 minutes. However, your dealer may need your vehicle for a longer period of time due to vehicle scheduling issues.

Have you changed address or sold the vehicle? If you have changed your address or sold the vehicle, please fill out the enclosed postcard and mail it to:

If you have any trouble getting your vehicle repaired promptly and at no charge, please inform us by calling:

Mitsubishi Customer Relations Department
(888) MITSU-2002 (888-648-7820)
(Central Standard Time) Monday – Saturday 7 a.m. to 10 p.m.

If after contacting Mitsubishi Customer Relations, you still have a problem having your vehicle repaired promptly and without charge, write to the Administrator, National Highway Traffic Safety Administration, 400 Seventh Street S.W., Washington, D.C. 20590, or call the Auto Safety Hotline toll-free (888) 327-4236.

Mitsubishi is committed to making your safety our first concern and we sincerely regret the inconvenience to you caused by this recall.

Sincerely,

SR-01-008
C0109WXX

Richard Donnelson
Director, Customer Relations

[Notice to Lessors: If you are a lessor of five or more leased vehicles as of the date of this letter, you have an obligation under federal law (49 CFR Part 577) to provide the lessee of the above referenced vehicle with a copy of this letter by first class mail within ten days of receipt. Also, you must maintain a record which identifies the lessee to whom you sent a copy of this letter, the date you sent it, and the vehicle identification number (VIN) of the subject vehicle.]

**** ADVANCE TECHNICAL INFORMATION NOTICE ****

DATE: September 24, 2001
TO: Mitsubishi Motors Service Managers
FROM: Peg Dilworth-Hunt, Vice President, Fixed Operations
RE: Montero Safety Recall and Product Improvement Notification –
(SR-01-008, SC-01-001, SC-01-002)
ATIN NO. ATIN-01-SR-010

BACKGROUND

MMSA is launching one (1) Safety Recall and two (2) Service Campaigns on some 2001 and 2002 Monteros as follows:

Item	Vehicle Production Dates	# of Vehicles
Safety Recall: Hydraulic Brake Booster Accumulator	Produced between 12/15/1999 & 6/20/2001	39,020
Product Improvement: A/T Cooler Cracking	Produced between 1/11/2000 & 12/27/2000	28,271
Product Improvement: Wiper Arm Pivot Arm Nut	Produced between 12/15/1999 & 3/5/2001	34,229

The safety recall impacts about 39,000 vehicles. Most of these vehicles will also require one of the product improvements and some of them will require both product improvements.

Note: Always verify recall and campaign application based on receipt of customer letter and MMSA Warranty System.

IMPLEMENTATION SCHEDULE

- Monday, September 24th, 2001 - Technical Information available on Diamond Dealer Link
- Technical Information mailed to Retailers
- Monday, October 1st, 2001 - Notifications mailed to customers.

Note: Customers will receive one letter for the recall and another for either one or both of the product improvement(s), based on the VIN.

- An initial supply of parts will be force-allocated to dealers to ensure adequate supply to all.

REFERENCE MATERIALS

Technical Service Bulletins

- SR-01-008 Hydraulic Brake Booster Accumulator
- SC-01-001 A/T Cooler Cracking
- SC-01-002 Wiper Arm Pivot Bolt Nut

Please be certain that you conduct a meeting with your Service Advisors and Technicians to ensure their complete understanding of these campaigns. It is critical that your personnel understand which repair procedures the customer will require prior to booking the appointment to ensure adequate parts availability quick repair turnaround.

File under the ATIN tab in the Dealer Service Information Binder

ATTACHMENT FOR QUESTION 12

- ◆ **PARTS DEMAND FOR P/N MR527718**
- ◆ **PARTS DEMAND FOR P/N MR977411**
- ◆ **PARTS DEMAND FOR P/N MR977223**
- ◆ **PARTS DEMAND FOR P/N 4630A11**

PARTS DEMAND FOR P/N MR527718

YEAR MONTH	QUANTITY
2000 AUG	1
2001 JAN	1
2001 FEB	6
2001 MAR	5
2001 APR	32
2001 MAY	75
2001 JUN	111
2001 JUL	41
2001 AUG	61
2001 SEPT	3
2001 OCT	0
2001 NOV	1
2001 DEC	13
2002 ALL	0
2003 ALL	0
2004 JAN	0
2004 FEB	0
2004 MAR	0
2004 APR	0
2004 MAY	1
2004 JUN	0
2004 JUL	0
2004 AUG	1
2004 SEPT	0
2004 OCT	0
2004 NOV	0
2004 DEC	0
2005 ALL	0
2006 JAN	5
2006 FEB	0
2006 MAR	0
2006 APR	0
2006 MAY	0
2006 JUN	0
2006 JUL	0
2006 AUG	0
2006 SEPT	0
2006 OCT	0
2006 NOV	0
2006 DEC	0
TOTAL	357

PARTS DEMAND FOR P/N MR977411

YEAR MONTH	QUANTITY
2001 JUN	163
2001 JUL	258
2001 AUG	246
2001 SEPT	202
2001 OCT	4
2001 NOV	1
2001 DEC	448
2002 JAN	0
2002 FEB	0
2002 MAR	0
2002 APR	0
2002 MAY	0
2002 JUN	1
2002 JUL	0
2002 AUG	0
2002 SEPT	0
2002 OCT	1
2002 NOV	0
2002 DEC	0
2003 ALL	0
2004 ALL	0
2005 ALL	0
2006 JAN	6
2006 FEB	0
2006 MAR	0
2006 APR	0
2006 MAY	0
2006 JUN	0
2006 JUL	0
2006 AUG	0
2006 SEPT	0
2006 OCT	0
2006 NOV	0
2006 DEC	0
TOTAL	1330

PARTS DEMAND FOR P/N MR977223

YEAR MONTH	QUANTITY
2001 SEPT	8382
2001 OCT	12748
2001 NOV	4412
2001 DEC	1755
2002 JAN	1131
2002 FEB	858
2002 MAR	653
2002 APR	774
2002 MAY	687
2002 JUN	529
2002 JUL	554
2002 AUG	529
2002 SEPT	367
2002 OCT	259
2002 NOV	324
2002 DEC	187
2003 JAN	244
2003 FEB	252
2003 MAR	224
2003 APR	282
2003 MAY	231
2003 JUN	227
2003 JUL	279
2003 AUG	210
2003 SEPT	163
2003 OCT	150
2003 NOV	94
2003 DEC	112
2004 JAN	100
2004 FEB	94
2004 MAR	128
2004 APR	73
2004 MAY	20
2004 JUN	9
2004 JUL	2
2004 AUG	6
2004 SEPT	10
2004 OCT	12
2004 NOV	9
2004 DEC	1
2005 JAN	1
2005 FEB	3
2005 MAR	13
2005 APR	8
2005 MAY	1
2005 JUN	4
2005 JUL	10
2005 AUG	2

YEAR MONTH	QUANTITY
2005 SEPT	3
2005 OCT	5
2005 NOV	1
2005 DEC	2
2006 JAN	2
2006 FEB	0
2006 MAR	0
2006 APR	1
2006 MAY	2
2006 JUN	0

TOTAL

37123

PARTS DEMAND FOR P/N 4630A011

YEAR MONTH	QUANTITY
2004 MAR	0
2004 APR	44
2004 MAY	95
2004 JUN	149
2004 JUL	128
2004 AUG	100
2004 SEPT	97
2004 OCT	121
2004 NOV	71
2004 DEC	115
2005 JAN	117
2005 FEB	109
2005 MAR	132
2005 APR	164
2005 MAY	152
2005 JUN	192
2005 JUL	163
2005 AUG	183
2005 SEPT	147
2005 OCT	114
2005 NOV	157
2005 DEC	138
2006 JAN	161
2006 FEB	185
2006 MAR	263
2006 APR	277
2006 MAY	298
2006 JUN	162
TOTAL	4034