

COMPLAINT FOR FAILURE TO REMEDY WITHOUT CHARGE SAFETY DEFECTS IN AUTOMOBILE

VEHICLES AND THEIR PARTS AND FOR DECEPTIVE BILLING PRACTICES RELATED TO SAME

1. Complainant [REDACTED] is an adult individual who at all relevant times has resided in Massachusetts. She currently resides at [REDACTED] Braintree, Massachusetts [REDACTED].
2. On May 7, 2012, [REDACTED] purchased a new 2012 Mitsubishi Outlander Sport ES ["Vehicle"], from Quirk Mitsubishi, a dealership licensed by Mitsubishi Motors North America, Inc. ["Mitsubishi"]. (A copy of a document evidencing the date of [REDACTED] purchase of the Vehicle is attached hereto as Ex. 1 [REDACTED] still owns and operates the Vehicle as of the date of the service of this Complaint.
3. Mitsubishi is the manufacturer of Mitsubishi automobiles sold in the U.S., including the Vehicle. As the manufacturer of automobiles Mitsubishi has the duty to correct safety defects which are the subject of a recall vehicles that have safety related defects or do not meet Federal safety standards. "Recall" as used herein refers to recalls mandated or undertaken under the U.S. Code for Motor Vehicle Safety (Title 49, Chapter 301). A Recall is necessary 1) when a motor vehicle or item of motor vehicle equipment does not comply with a Federal Motor Vehicle Safety Standard. Recall is also necessary 2) when there is a safety-related defect in the vehicle or equipment.

4. The National Traffic and Motor Vehicle Safety Act ("NTMVSA") gives the National Highway Traffic Safety Administration ("NHTSA") the authority to issue vehicle safety standards and to require manufacturers to issue Recalls or administer Recalls.
5. On information and belief, automobile manufacturers, including Mitsubishi, are given three options to address a vehicle or equipment defect which is subject to a Recall: repair, replace or refund the purchase price of the vehicle or equipment. If the repair, replacement or refund is performed within fifteen (15) years of the original purchase of the vehicle, it must be performed at no charge to the purchaser or other consumer.
6. Quirk Mitsubishi closed after ██████████ purchased the Vehicle. As a result, ██████████ ██████████ sought and received services and parts for the Vehicle from Cape & Islands Mitsubishi ("C&IM") beginning in 2015.
7. C&IM is now located at 527 Station Avenue, South Yarmouth, Massachusetts, 02664.
8. When she received services, parts and other items for which she was billed, ██████████ provided to C&I M information sufficient to show that she was the original purchaser and owner of the Vehicle.
9. "C&IM" is a licensed dealer, distributor and servicer of and for Mitsubishi.
10. In October of 2018, ██████████ experienced problems with her Vehicle, and sought service from C&IM to fix the Vehicle.

11. C&IM made various repairs to the Vehicle, and presented to [REDACTED] a written invoice, number [REDACTED], dated 10/29/2018 [“Invoice [REDACTED]”]. A copy of Invoice [REDACTED] is attached hereto as Ex. 2

12. In Invoice [REDACTED] C&IM represented to [REDACTED] that she owed C&IM a total of \$2,174.99. Invoice [REDACTED] on its second page, stated “CUSTOMER TOTALS: \$2174.99.” [REDACTED] timely paid C&IM the total amount billed by it to her in [REDACTED] (Ex. 2)

13. Invoice [REDACTED] itemized its charges to [REDACTED] for five different specified Jobs.

14. As shown on Invoice [REDACTED] C&IM charged [REDACTED] for Job # 1 at \$1559.94 to “REPLACE CLUTCH BLEED SYSTEM AND TEST DROVE.” (Ex. 2)

15. As shown on Invoice [REDACTED], C&IM charged [REDACTED] for Job # 2 at \$615.05 for “REPLACED FRONT CROSS MEMBER.” (Ex. 2)

16. Invoice [REDACTED] shows Three of the jobs (JOB # 3; JOB # 4; and JOB # 5) were performed by C&IM and billed to [REDACTED] for C&IM’s labor, parts, taxes, and “MISC.,” described as “PERFORM RECALL C1611Z WIPER MOTOR” (JOB # 3); “PERFORM RECALL C1614Z TAILGATE STRUTS” (JOB # 4); and “PERFORM RECALL C1806Z WIPER LINKAGE” (JOB # 5) (Ex. 2). Thus, while C&IM recognized in

Invoice [REDACTED] that it had performed Jobs ## 3, 4 and 5 to remedy defects reflected in Mitsubishi Recalls, it knowingly charged [REDACTED] for labor, parts, taxes and "MISC" in remedying safety problems which were the subject of Mitsubishi's Recalls.

17. Upon information and belief, C&IM had a policy, practice and custom of billing, charging and demanding payments to it from purchasers of Mitsubishi vehicles for labor, parts, taxes and "MISC" performed in connection with remedying safety defects in connection with Mitsubishi's Recalls.

A. A copy of Mitsubishi's March 2018 Safety Recall Bulletin for the "OUTLANDER SPORT WINDSHIELD WIPER LINK-SAFETY RECALL CAMPAIGN-REVISED" ("Windshield Wiper Recall") is attached hereto as Ex. 3

B. A copy of Mitsubishi's January 17, 2017 Bulletin on the subject of "LIFT GATE GAS SPRING CORROSION-SAFETY RECALL CAMPAIGN" is attached hereto as Ex. 4. It describes Mitsubishi's "recall campaign ID [as] C1614Z" and the parts needed as "Tailgate Strut Kit."

18. On September 25, 2021, [REDACTED] returned to C&IM because the windshield wiper spray on the Vehicle was not working. C&IM informed [REDACTED] that C&IM that she needed a new motor and reserve tank for the windshield wiper on the Vehicle but that C&IM did not have those items in stock at that time.

19. On October 2, 2021, [REDACTED] returned to C&IM, at which time C&IM fixed the Vehicle's windshield wiper problem. [REDACTED] was once again presented by C&IM

with an invoice for her to pay for services, parts and other items for C&IM's work to remedy Mitsubishi's Recall, but she did not retain the invoice.

20. Also on October 2, 2021, C&IM informed [REDACTED] that there was a Recall for the front cross member on the Vehicle. A copy of the Part 573 Safety Recall Report dated May 18, 2020 ("May 18, 2020 Recall Report") is attached hereto as Ex. 5. The May 18, 2020 Recall Report describes the "defect" as

The inside and outside surfaces of the front cross members used on certain vehicles, if exposed long term to snowmelt water and anti-freezing agents, may corrode due to insufficient performance of the rust protection. Should significant corrosion occur over time, a lower control arm could eventually become detached resulting in loss of vehicle control and a potential collision.

21. [REDACTED] advised C&IM on October 2, 2021 that she had paid it for the repair of the front cross member on the Vehicle in October 2018. She was charged for the work described as Job # 2 on Invoice [REDACTED] (Ex 2 [REDACTED] asked for a refund of the amount she paid for the work on Job # 2. C&IM informed [REDACTED] that it would contact Customer Relations of Mitsubishi to assist her in obtaining the refund.

22. On October 6, 2021, C&IM contacted [REDACTED] and informed her that to receive a refund for payments made to C&IM for repairs subject to Recall, she should contact Mitsubishi's Customer Relations department in Tennessee at callcenterweb@mitsubishicars.com. ["Mitsubishi Call Center"]

23. On October 7, 2021, [REDACTED] emailed Mitsubishi at the Mitsubishi Call Center concerning her request for a refund. A copy of that email is attached hereto as Ex. 6. She sent a follow-up email to the Mitsubishi Call Center on October 11, 2021. A copy of the follow up email is attached hereto as Ex. 7.
24. On October 26, 2021, and because she had not received any response to her October 7, 2021 and October 11, 2021 emails (Exs. 6 and 7), [REDACTED] called by phone to Mitsubishi Customer Relations. She was placed on hold for ten (10) minutes. A representative then answered. After [REDACTED] described the claim she had made in her October 7, 2021 and October 11, 2021 emails, the representative first told her that her claim was untimely because it was past the limitations period from the date of the purchase of the Vehicle. The representative then stated that he would file the claim. He placed [REDACTED] on hold and hung up on her. The duration of the call was 22 minutes, 37 seconds.
25. [REDACTED] called back to the Mitsubishi Customer Relations phone number on November 1, 2021. She waited on hold for about 30 minutes. The representative who finally answered her call apologized for the conduct of the prior representative. She informed [REDACTED] that the customer service representative assigned to her case was unavailable, but that someone would call her back within 48 hours.
26. Because she received no response to her requests for refunds that she sent to and called about to Mitsubishi's Customer Relations, [REDACTED] called that department again on November 5, 2021. She was placed on hold for more than twenty (20) minutes. The

representative who answered informed [REDACTED] that she would place on the record a "Callback activity request", which should trigger a response to [REDACTED]. The representative also stated that she would transfer [REDACTED] to the assigned representative's voicemail. The transfer to the assigned representative's voicemail did not go through. [REDACTED] did not receive any response to her requests for refund of payments made by her for work performed to remedy recalls.

27. [REDACTED] made an additional phone call to Mitsubishi's Customer Relations on November 11, 2021. She was placed on hold for more than thirty (30) minutes. The representative that answered informed her that the representative assigned to her matter was unavailable. The answering representative told [REDACTED] that she would put her call through to her assigned representative's voicemail. [REDACTED] was not transferred to the "assigned representative's" voicemail. Instead, the answering representative hung up on [REDACTED]. [REDACTED] then called back to the same Customer Relations number. She was again placed on hold for more than thirty (30) minutes. A representative named Antoine answered the phone. He apologized that the previous representative had hung up on [REDACTED]. Antoine said that he would put in a request for an "emergency callback." Antoine informed [REDACTED] that there was no representative assigned to respond to her requests for refunds. He asked and [REDACTED] provided to him her phone number and her time zone. He told her that someone should call her back within the next 24 hours [REDACTED] never received any response to her repeated requests for refunds of amounts that she paid for repairs which were the subject of Recalls by Mitsubishi due to safety defects relevant to the Vehicle.

28. On November 15, 2021, [REDACTED] called a different phone number that she found for Mitsubishi's Customer Relations (1-888-648-7820). In that call she talked to a representative named Shana. Shana informed [REDACTED] that her claim(s) did have a case manager named Michael Sparks, but he was unavailable at the time of the call. Shana placed [REDACTED] on hold, but returned to the call and told [REDACTED] that she had talked to a manager and that [REDACTED] had to submit ^{a receipt} proof of her purchase of the ^{repairs} Vehicle by email to Mitsubishi's Call Center. [REDACTED] informed Shana that she had already submitted to Mitsubishi's Call Center her proof of her purchase of the car. [Ex.??] Shana informed [REDACTED] that it would take six (6) to eight (8) weeks for her claim to be processed by Mitsubishi's Call Center.

29. [REDACTED] made an additional request for information on the status of her claim(s) for refunds for amounts she paid to fix defects in her Vehicle that were the subject of Recalls. On December 15, 2021, she spoke again to Antoine, a representative of Mitsubishi's Customer Relations. Antoine told her at that time that the person who was handling her matter was in a meeting, but would get back to her.

30. Neither Mitsubishi nor C&IM have ever responded to [REDACTED]'s efforts and claim(s) that [REDACTED] asserted against them for refunds of amounts that she paid for work performed and billed by C&IM that were necessary to remedy specific Mitsubishi Recalls applicable to [REDACTED]'s Vehicle.

31. As set forth above, [REDACTED] was provided with inconsistent information as to whether or not she had made a claim against Mitsubishi and/or C&IM, whether there was a representative assigned to respond to her claim(s), and whether or not she would receive a response or further information concerning her claim(s).
32. [REDACTED] has exhausted any administrative procedures established or maintained by Mitsubishi and/or C&IM.
33. [REDACTED] brings this Complaint against Mitsubishi because it is the manufacturer of [REDACTED]' Vehicle and millions of other vehicles, and it has the obligation to provide appropriate remedies for safety defects which are the subject of Recalls without charge to owners and purchasers of vehicles manufactured by it.
34. Mitsubishi maintains a Customer Call Center to provide information and assistance to owners and purchasers of the vehicles that it manufactures, including assistance to facilitate the operation of its duties and obligations to owners and purchasers of its vehicles in connection with Recalls and refunds of amounts paid by owners and purchasers for services, parts and other expenses related to fixing vehicles with safety defects that are subject of Recalls by Mitsubishi.
35. Mitsubishi, by the actions and omissions of its Customer Call Center, website, customer relations representatives and others failed to properly respond to [REDACTED]' multiple requests for assistance in obtaining refunds for dollar amounts charged to her for payment for parts, services and expenses related to fixing her Vehicle related to Mitsubishi's Recalls.

36. Rather than assisting [REDACTED] to obtain all relief to which she was entitled because her Vehicle was the subject of several Mitsubishi Recalls, Mitsubishi's actions and omission were designed to frustrate and obstruct [REDACTED] efforts to obtain any and all relief to which she was entitled because her Vehicle was the subject of several Mitsubishi Recalls.

37. All of the Mitsubishi Recall expenses paid by [REDACTED] occurred within fifteen (15) years of the date of her purchase of the Vehicle as its original and continuing purchaser and owner.

38. C&IM, as a Mitsubishi dealer, has the duty and obligation to perform services for fixing Mitsubishi Recall related safety defects, without charging purchasers and owners of Mitsubishi vehicles for the parts, labor, taxes and MISC required in remedying the safety defects. C&IM violated its duty and obligations when it presents invoices to purchasers and owners informing them that they were responsible for paying for parts, labor, taxes and MISC required in remedying the safety defects on Mitsubishi manufactured vehicles subject to Mitsubishi Recalls.

REQUEST FOR RELIEF FROM MITSUBISHI AND C&IM

39. [REDACTED] requests relief in the form of refunds of all amounts charged to and paid by her for parts, labor, taxes and MISC to remedy safety defects in her Vehicle which were the subject of Mitsubishi Recalls within fifteen (15) years of the filing of this Complaint.

40. [REDACTED] requests declaratory and/or injunctive relief preventing C&IM from any further conduct presenting invoices and demanding purchasers and owners of Mitsubishi vehicles for labor, parts, taxes, and MISC other charges for work performed to remedy safety defects subject to Mitsubishi Recalls in violation of federal and state law.
41. [REDACTED] requests declaratory and/or injunctive relief requiring Mitsubishi to maintain an appropriate system for receiving and responding to complaints regarding the allocation to purchasers and owners of Mitsubishi vehicles the financial responsibility for paying for services, parts, taxes and other expenses required to remedy safety defects subject to Mitsubishi Recalls.
42. [REDACTED] requests such other relief allowed under applicable law.
43. Copies of this Complaint and Exhibits have been served on the following by overnight mail, return receipt requested.

Mitsubishi Motors North America, Inc.
6400 Katella Avenue
Cypress, California 90630

Cape & Islands Mitsubishi
527 Station Avenue
South Yarmouth, Massachusetts 02664

National Highway Traffic Safety Administration
1200 New Jersey Avenue, SE
Washington, D.C. 20540

A claim based on the conduct of Mitsubishi Motors North America, Inc. and Cape & Islands Mitsubishi set forth herein was served by United States Mail to

Office of the Attorney General
Consumer Advocacy & Response Division
One Ashburton Place, 18th floor
Boston, MA 02108

This Complaint is filed by

[REDACTED]

Braintree, MA

[REDACTED]

MOTOR VEHICLE PURCHASE CONTRACT



QUIRK
AUTO DEALERS

99 MCGRATH HIGHWAY
QUINCY, MA 02169
617/773-8000

Exhibit #1

2012 [Redacted] [Redacted] [Redacted] SALES PERSON: RAMON SILVERO
[Redacted] HOME PHONE: [Redacted] BUSINESS: [Redacted]

ENTER MY ORDER FOR ONE NEW FORMER USE DEMONSTRATOR POLICE CAR REBUILT INSURANCE TOTAL
USED (if applicable) FORMER LEASED CAR FORMER DAILY RENTAL TAXICAB
Year: 2012 Make: MITSUBISHI Model Name: Outlander Sport Body Style/Type: UT Model No: OS48-A Transmission: Standard Automatic (Speeds): 4 Cyl: 5 Pass: 4 Doors: 4
Vehicle Identification No: JA4AP3AUBC [Redacted] Color 1st: P26/RED Interior 1st: [Redacted] Top: [Redacted] Odometer: [Redacted] Mile. 9 Approx. Delivery Date: 05/07/2012

Model: [Redacted] Year: [Redacted] Make: [Redacted] Color: [Redacted]
V.I.N. Type: [Redacted]
Odometer: [Redacted] (mi) (km)
Transmission: Standard (Speeds) Auto
No. of Cyl: [Redacted] Pass: [Redacted] Doors: [Redacted]
Salvage Title: Yes No

WARRANTY INFORMATION
 This vehicle carries an express warranty. You may obtain a copy of such warranty from the dealer upon request.
 This vehicle does not carry an express warranty.
(Initial Applicable Statement)

Social Security No. [Redacted]
Date of Birth: [Redacted]
Employer ID No. [Redacted]
Email Address: [Redacted]
Price of Unit: AS EQUIPPED \$ 18998 00

PREVIOUS OWNER: [Redacted]
City/State/Zip: [Redacted]
LIENHOLDER: [Redacted]
Address: [Redacted]
City/State/Zip: [Redacted]
Acct. No. [Redacted] Check No. [Redacted]

REGISTRATION FEE/TITLE FEE SALES TAX
Application for Title
Application for Reg. New Transfer
Registration No. [Redacted]
Registration Fee \$ 50 00
Title Fee \$ 75 00
Mass. Sales Tax \$ 1099 88

CASH DIFFERENCE 18098 00
Additional Equipment/Items: [Redacted]

Additional Information Vehicle Purchased:
LIENHOLDER: ROCKLAND FEDERAL CREDIT UNION
Address: 241 UNION STREET
City/State/Zip: ROCKLAND MA 02370
INSURANCE CO: MET LIFE
Agent/Branch: [Redacted]
Address/City: [Redacted]

*Sales Tax amount is included in right hand column only when dealer check is issued in payment of Mass. Sales Tax.

In the event I fail to take delivery of the vehicle purchased by me within forty-eight (48) hours after I have been notified by you that it is ready for delivery and pay the total contract price in the manner indicated, my deposit in the amount of \$ [Redacted] may, at your option, be retained by you to compensate you in whole or in part for any loss sustained by you. Your right to retain my deposit shall be in addition to and not instead of any other right or remedy provided by applicable law including, without limiting the generality of the foregoing, the sale of the car or truck I agree to purchase. If the amount of my deposit exceeds actual damages sustained by you, you will promptly refund the difference to me.

I certify that the vehicle being traded does not have a salvage/reconstructed title.

CREDIT CARD LIMIT \$1,500.00

ALL REBATES AND SALES INCENTIVES OFFERED BY THE MANUFACTURER OR DISTRIBUTOR ARE HEREBY ASSIGNED TO THE PURCHASER.
Purchaser's Initials [Redacted]

1. Total Price	\$ 18098 00
2. Discount	\$ N/A
3. Trade-In Allowance	\$ N/A
4. Rebates	\$ 500.00
5. Trade Difference (line 1 - lines 2, 3, & 4)	\$ 17598 00
6. *Mass Sales Tax (6.25% of line 5)	1099 88
7. Documentary Preparation	\$ 299 00
8. INSPECTION STICKER	\$ 29 00
9. REGISTRATION	\$ 50 00
10. TITLE	\$ 75 00
11. Other EXT, WARR.	\$ N/A
TOTAL CONTRACT PRICE (Total of line 5, 6, 7, 8, 9, 10 & 11)	\$ 19150 88
Balance Due on Trade-In	\$ N/A
Subtotal (Total of lines 12 & 13)	\$ 19150 88
15. Deposit	N/A
16. Amount to be Financed	4598.00
17. Cash Due on Delivery	14552.88
18. TOTAL PAYMENT (Total of lines 15, 16, & 17) (line 18 must equal line 14)	\$ 19150 88

This contract is not binding upon either dealer or purchaser until signed by dealer or its authorized representative. PURCHASER MAY CANCEL THIS CONTRACT AND RECEIVE A FULL REFUND AT ANY TIME UNTIL S/HE RECEIVES A COPY OF THIS CONTRACT SIGNED BY AN AUTHORIZED DEALER REPRESENTATIVE. PURCHASER MUST GIVE WRITTEN NOTICE OF CANCELLATION TO THE DEALER.

The front and back of this order comprise the entire agreement between the dealer and purchaser and no other agreement or understanding has been made or entered into. Purchaser represents and warrants that no credit other than that stated above has been extended to him/her by dealer. Purchaser represents and warrants that s/he has read and understands the materials listed on this motor vehicle purchase contract. Purchaser acknowledges receipt of signed copy of this motor vehicle purchase contract.

[Redacted Signature]
Approved Authorized Dealer Representative

DEALER COPY
Cape & Islands
Mitsubishi

760 Route 28 South
 Yarmouth MA 02664
 Phone: 508-394-8000

10/29/2018 10:11:08

[REDACTED]		Stock #	Dealer #	Invoice Date	Invoice #
		[REDACTED]	20074	10/29/2018	[REDACTED]
[REDACTED]		Mileage In	Mileage Out	Lot #/Mat #	Color
		60707	60707		RED
QUINCY, MA [REDACTED]		Year/Make/Model		Prod Date	R.O. Date
		2012 MITSUBISHI OUTLANDER SPORT ES		//	10/24/2018
[REDACTED]		Vehicle ID #		Tech & #	P.O. #
		JA4AP3AU8C [REDACTED]			
Extended Warranty Co.		Policy #	Deductible	Auth. #	Engine Hours
Residence Phone	Business Phone	Cellphone	Service Writer Delivery Signature		Reprint # 2
[REDACTED]		[REDACTED]		[REDACTED]	

Type: C JOB # 1	Tech: WAYNE MOREA	Lbr/Pts Cost \$210.00 / \$666.17			
Tech Lic:					
Complaint: CUSTOMER STATES CEHICLE WONT MOVE					
Cause: FAULTY CLUTH					
Correction: REPLACE CLUTCH BLEED SYSTEM AND TEST DROVE					
Part:	2301A058	DISC, CLUTCH Qty: 1 97.64 \$122.05			
Part:	MN132330	COVER ASSY, CLUTCH Qty: 1 134.81 \$168.51			
Part:	2324A080	CYLINDER, CLUTCH RELEASE Qty: 1 129.40 \$161.75			
Part:	2324A023	ADAPTER, CLUTCH RELEASE Qty: 1 15.52 \$31.04			
Part:	MN163878	FLYWHEEL ASSY Qty: 1 234.96 \$293.70			
Part:	1120A219	BOLT, FLYWHEEL, 12X24.8 Qty: 7 13.09 \$26.18			
Part:	MF472404	PIN, DOWEL, 8X18 Qty: 3 3.18 \$6.36			
Part:	MU001438	BOLT, T/M CONNECTING (WAS Qty: 6 4.08 \$8.16			
Part:	M522A148	OIL SEAL, T/M FR DIFF CA Qty: 1 5.59 \$11.18			
Part:	MZ320195	M/T FLUID, 75W-80 Qty: 3 27.90 \$46.50			
Misc:		enviromental waste removal fee \$2.35			
Misc:		SHOP SUPPLIES \$21.45			
Tech	Flag	Clock	Warr	Fail	QC
1: 92	6.00	0.00			
JOB TOTALS Labor: \$606.00		Parts: \$875.43	Tax: \$54.71	Misc: \$23.80	TOTAL: \$1559.94

Type: C JOB # 2	Tech: ZDRAVKO SIMOV	Lbr/Pts Cost \$60.90 / \$293.82			
Tech Lic:					
Complaint: CUSTOMER STATES FRAME ROTTED					
Cause: HOLES IN FRONT CROSS MEMBER					
Correction: REPLACED FRONT CROSS MEMBER					
Part:	4000A428	CROSSMEMBER, FR AXLE, NO. Qty: 1 293.82 \$300.00			
Misc:		enviromental waste removal fee \$0.80			
Misc:		SHOP SUPPLIES \$8.50			
Tech	Flag	Clock	Warr	Fail	QC
1: 87	2.90	0.00			
JOB TOTALS Labor: \$287.00		Parts: \$300.00	Tax: \$18.75	Misc: \$9.30	TOTAL: \$615.05

Type: W JOB # 3 *	Tech: WAYNE MOREA	Lbr/Pts Cost \$7.00 / \$175.00		
Tech Lic:				
Complaint: PERFORM RECALL C1611Z WIPER MOTOR				
Part:	MW400223	WINDSHIELD WIPER MOTOR Qty: 1 175.00 \$245.00		
Extended Warranty Pay	Factory Warranty Pay	Internal Pay	All labor charges are billed on flat rate hours unless otherwise noted.	Total Customer Pay
	646.46			2174.99



DEALER COPY
Cape & Islands
Mitsubishi

760 Route 28 South
 Yarmouth MA 02664
 Phone: 508-394-8000

10/29/2018 10:11:09

	License #	Stock #	Dealer # 20074	Invoice Date 10/29/2018
--	-----------	---------	-------------------	----------------------------

Tech	Flag	Clock	Warr	Fail	QC	
1: 92	0.20	0.00				

JOB TOTALS	Labor:\$20.20	Parts:\$245.00	Tax:\$0.00	TOTAL:\$265.20
------------	---------------	----------------	------------	----------------

Type: W JOB # 4 * Tech:WAYNE MOREA Lbr/Pts Cost\$17.50 / \$130.68
 Tech Lic:
 Complaint: PERFORM RECALL C1614Z TAILGATE STRUTS

Part:	5802A712	TAILGATE STRUT KIT	Qty: 1	130.68	\$182.95
Tech	Flag	Clock	Warr	Fail	QC
1: 92	0.50	0.00			

JOB TOTALS	Labor:\$50.50	Parts:\$182.95	Tax:\$0.00	TOTAL:\$233.45
------------	---------------	----------------	------------	----------------

Type: W JOB # 5 * Tech:WAYNE MOREA Lbr/Pts Cost\$24.50 / \$55.08
 Tech Lic:
 Complaint: PERFORM RECALL C1806Z WIPER LINKAGE

Part:	8251A100	ROD ASSY, WPR LINK, LHD	Qty: 1	55.08	\$77.11
Tech	Flag	Clock	Warr	Fail	QC
1: 92	0.70	0.00			

JOB TOTALS	Labor:\$70.70	Parts:\$77.11	Tax:\$0.00	TOTAL:\$147.81
------------	---------------	---------------	------------	----------------

CUSTOMER TOTALS: \$2174.99	Lbr/Pts Cost:\$319.90 / \$1320.75
Labor:\$893.00	Parts:\$1175.43
	Misc:\$33.10
	Tax:\$73.46

THANK YOU FOR LETTING US SERVICE YOUR VEHICLE!
 IF FOR ANY REASON YOU WERE NOT SATISFIED WITH THE SERVICE
 PERFORMED PLEASE FEEL FREE TO CONTACT US

Cash _____ Check _____ Credit Card _____

Customer Signature X _____

Extended Warranty Pay	Factory Warranty Pay 646.46	Internal Pay	All labor charges are billed on flat rate hours unless otherwise noted.	Total Customer Pay 2174.99
-----------------------	--------------------------------	--------------	--	-------------------------------



SAFETY RECALL BULLETIN

SUBJECT:		No: SR-18-004REV	
OUTLANDER SPORT WINDSHIELD WIPER LINK – SAFETY RECALL CAMPAIGN – REVISED		DATE: March 2018	
		MODEL: 2011–2016 Outlander Sport / RVR	
CIRCULATE TO:	<input checked="" type="checkbox"/> GENERAL MANAGER	<input checked="" type="checkbox"/> PARTS MANAGER	<input checked="" type="checkbox"/> TECHNICIAN
<input checked="" type="checkbox"/> SERVICE ADVISOR	<input checked="" type="checkbox"/> SERVICE MANAGER	<input checked="" type="checkbox"/> WARRANTY PROCESSOR	<input checked="" type="checkbox"/> SALES MANAGER

This bulletin supersedes SR-18-004, to correct the wiper motor part number on page 8, and to clarify that Part # 8250B137 cannot be used on Outlander Sport Windshield Wiper Motor recall. Revisions are italicized and indicated by ◀.

PURPOSE

This bulletin provides directions for replacing the windshield wiper link rod.

BACKGROUND

In the event that water drops down through the back side of the front deck garnish (the body piece between the hood and windshield), the front wiper link ball joint may experience excessive moisture and corrode. If this occurs, the resin case of the ball joint will wear prematurely due to the ball joint corrosion and the wiper link may ultimately separate causing the windshield wipers to stop operating. If wiper link separation occurs, the windshield wipers will become inoperative which could reduce driver visibility under certain conditions and increase the risk of a vehicle crash.

AFFECTED VEHICLES

2011 – 2016 Outlander Sport / RVR

IMPORTANT

Affected new or used inventory vehicles must be repaired before the vehicle is sold/delivered. Dealers must check their inventory vehicles' VINs on the Warranty Superscreen to verify whether the vehicle is involved in this recall campaign. It is a violation of Federal law for a dealer to sell/deliver a new motor vehicle or any new or used item of motor vehicle equipment (including a tire) covered by the notification under a sale or lease until the defect or noncompliance is remedied.

REQUIRED OPERATIONS

Before starting this campaign procedure, CHECK THE WARRANTY SUPERSCREEN to verify if the vehicle is an affected VIN for this campaign and that this campaign procedure has not already been completed. You must also check the Superscreen for any open **SR-16-010 (C1611Z or C1612Z)** campaign. To improve customer satisfaction and to prevent the customer from having to return for a separate repair, you must complete any open **SR-16-010** campaign at the same time as this campaign. The labor allowance for **SR-16-010** has been reduced to encourage the completion of both campaigns at the same time. Portions of **SR-16-010** have been incorporated to enable a smooth completion of both campaigns; however, you must make separate claims for **SR-16-010** and **SR-18-004**.

REQUIRED EQUIPMENT

- Precision Flathead Screwdriver
- Ornament Remover (Trim Stick)
- Bent Nose Pliers (45 Degrees)

- 19 mm Socket
- Adjustable Wrench
- Slip Joint Pliers
- Straight Edge / Ruler
- Hose
- Scissors
- Pry Bar
- Masking Tape
- Marker

WIPER LINK ROD ASSEMBLY REPLACEMENT PROCEDURE

⚠ CAUTION Do NOT mix old parts with new parts.

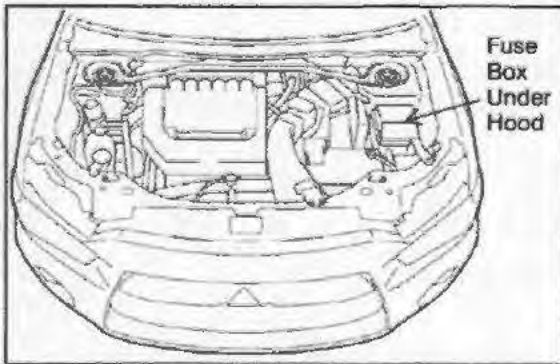

1. Obtain the Fuse Remover from the engine compartment fuse box.

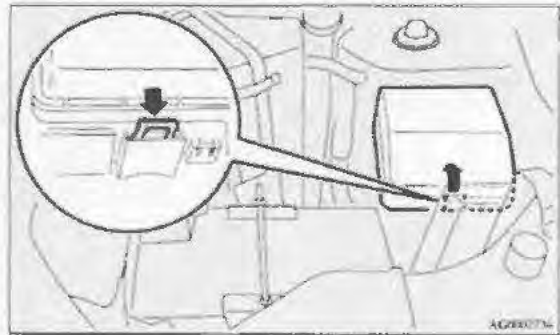

- a. Open the hood.
- b. Unlock the fuse box cover by pushing on the lock lever.

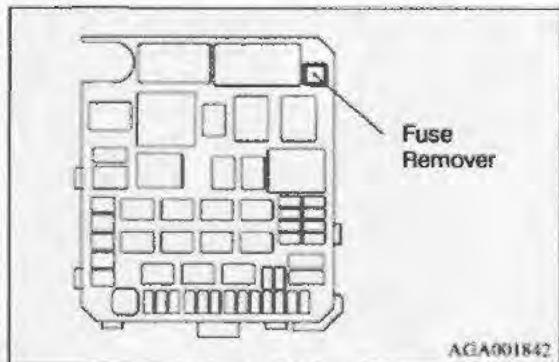

- c. Remove the Fuse Remover.

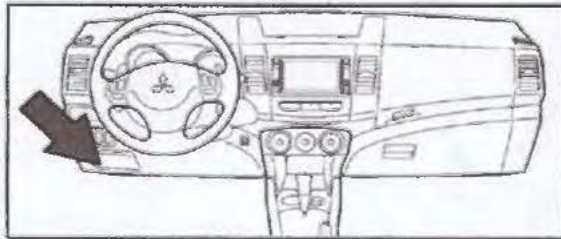

2. Locate the passenger compartment fuse lid.

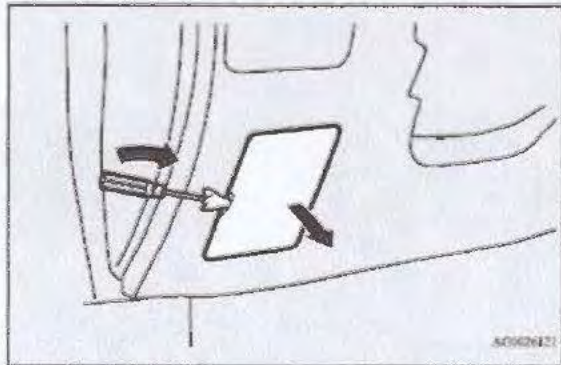

3. Remove the passenger compartment fuse lid.

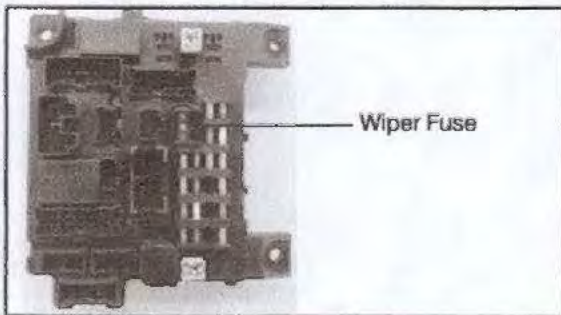

4. Using the Fuse Remover, locate and remove the green (30 A) Wiper Fuse.

Refer to "How to Use Fuse Remover" instructions below.

How to Use Fuse Remover

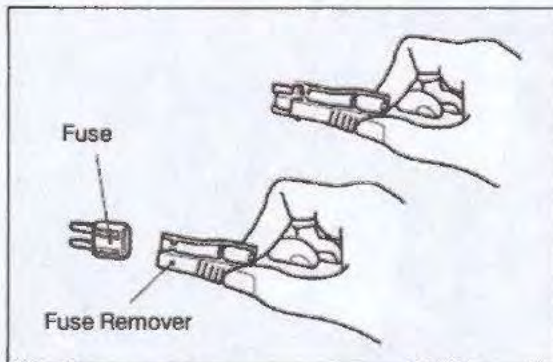

⚠ WARNING A Fuse Remover **MUST** be used to remove fuses. Use of other tools such as pliers can potentially result in thermal incidents.

!! IMPORTANT !! Before marking the windshield wiper positions, lift the wiper blade from the windshield and set it back down to ensure that they are resting in their intended positions.

!! IMPORTANT !! Use a fender cover, towel, or similar accessory to protect the fender.

5. Attach masking tape to the windshield and mark the wiper blades' positions as shown.



6. Remove the wiper arm blade assemblies.

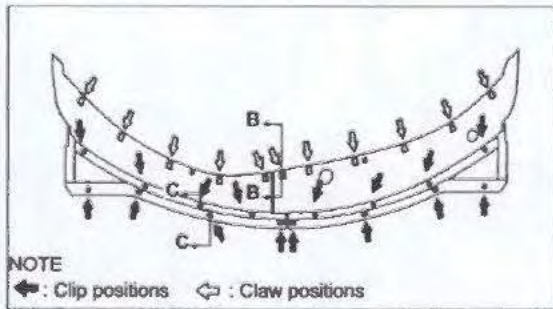

7. Remove front deck garnish.

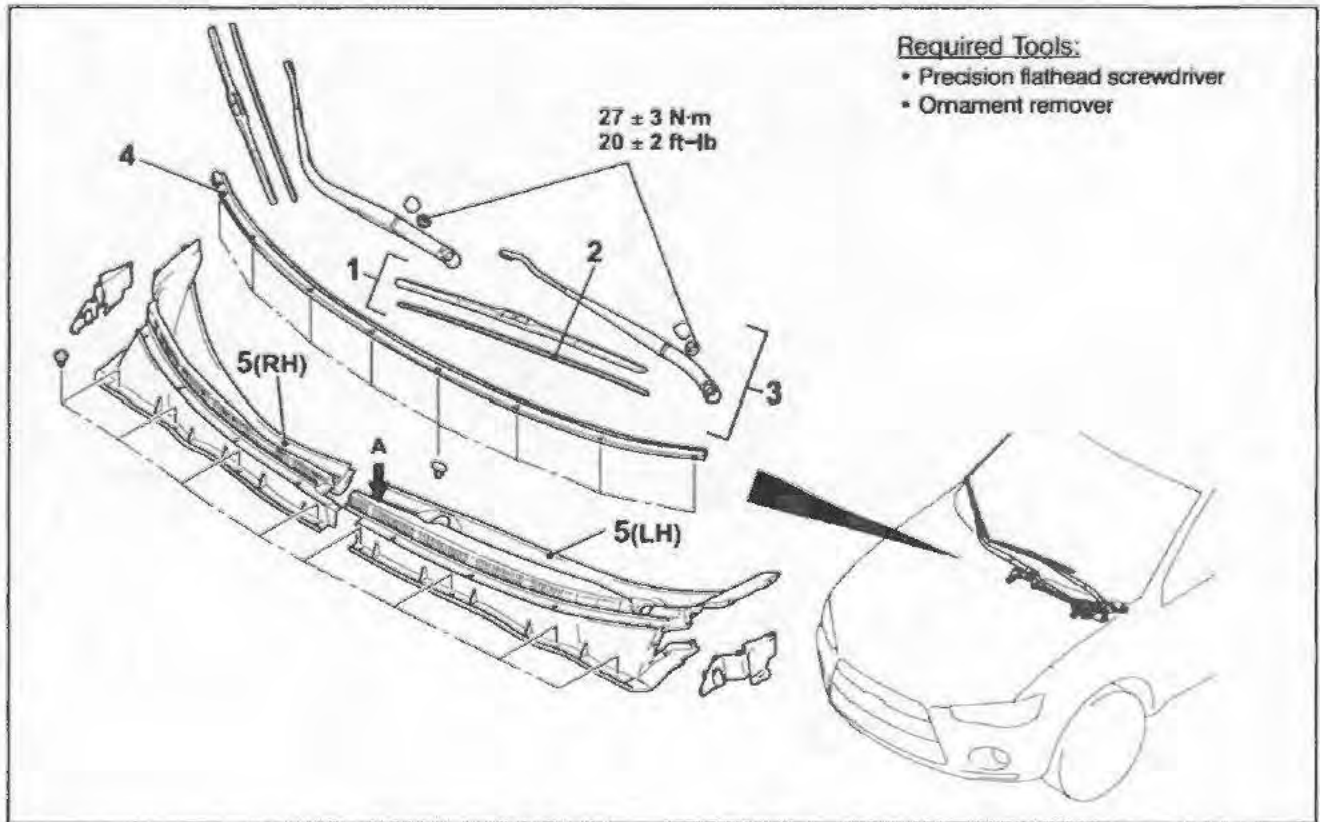

8. Remove the passenger side hood rear weatherstrip from the deck garnish.
NOTE: Do not remove the driver side hood rear weatherstrip from the deck garnish (for easier reassembly).
9. Protect the windshield with a protective slit hose.
 - a. Make a protective slit hose as shown below.

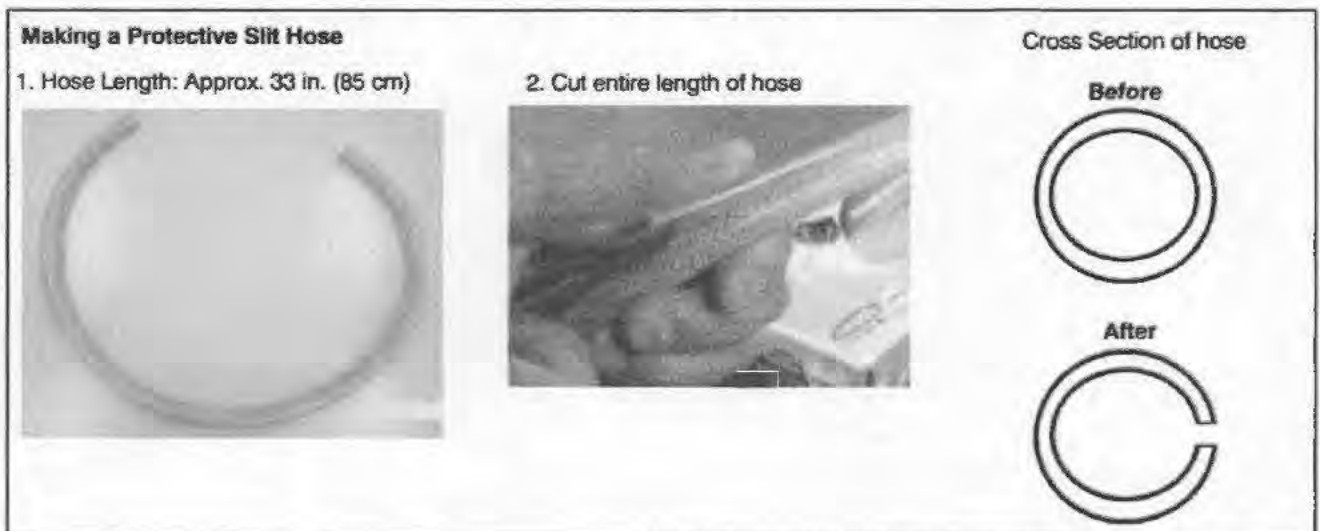

- b. Cover the edge of the windshield with the protective slit hose.

Protective Slit Hose on Windshield

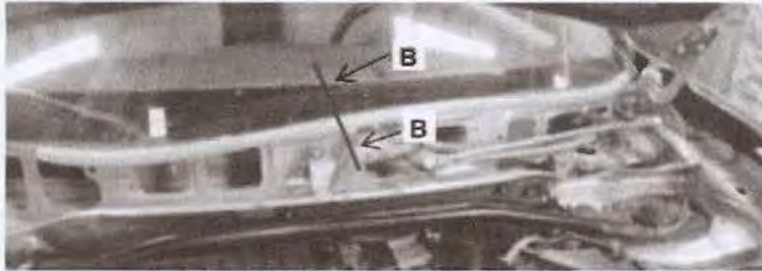

Cross Section B-B

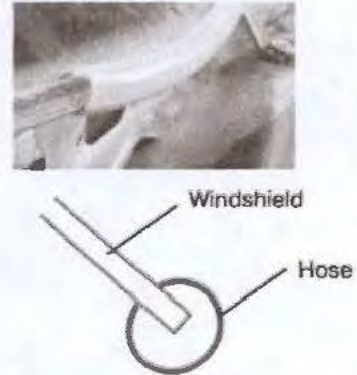

10. Unbolt the wiper link assembly, disconnect the wiper motor connector, and remove the wiper link assembly from the vehicle.

CAUTION Clamp the wiper link assembly at the connection pipe only.



11. Place the wiper link assembly in a vice with the motor axle pointing up.

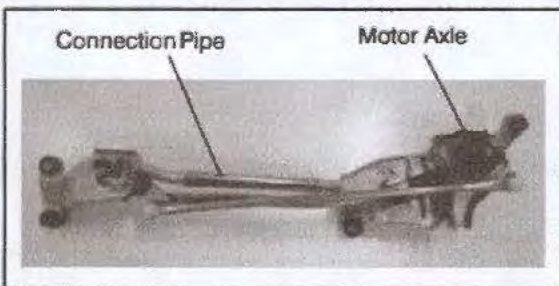

CAUTION: Clamp ONLY the connection pipe section.

12. Use a pry bar or similar device to separate the wiper link rod from the wiper link plate. Insert the pry bar and lift using leverage in area shown below.

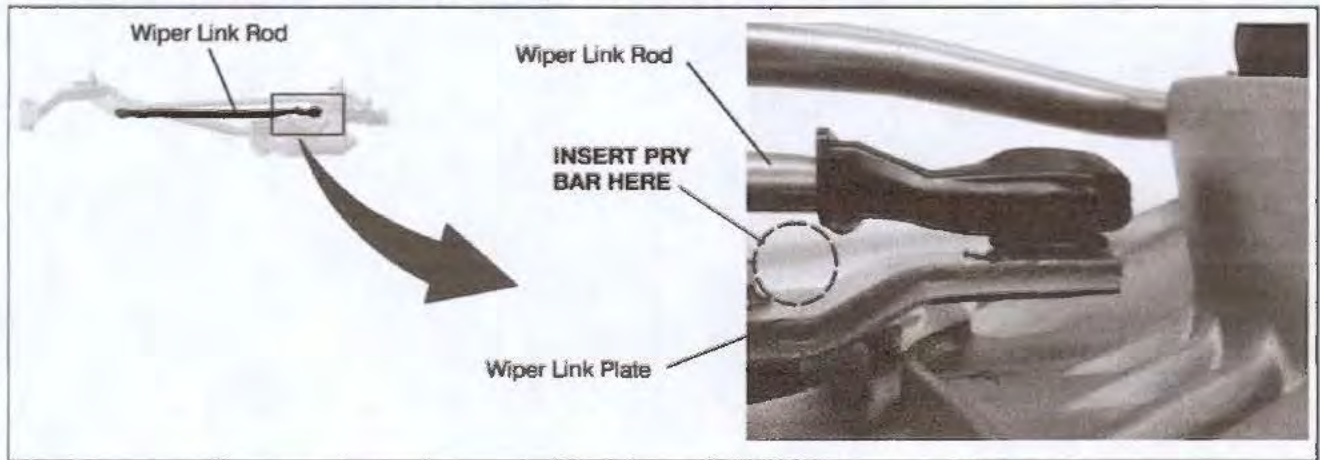

CAUTION Turn the link plate slowly to avoid internal damage to the wiper motor.

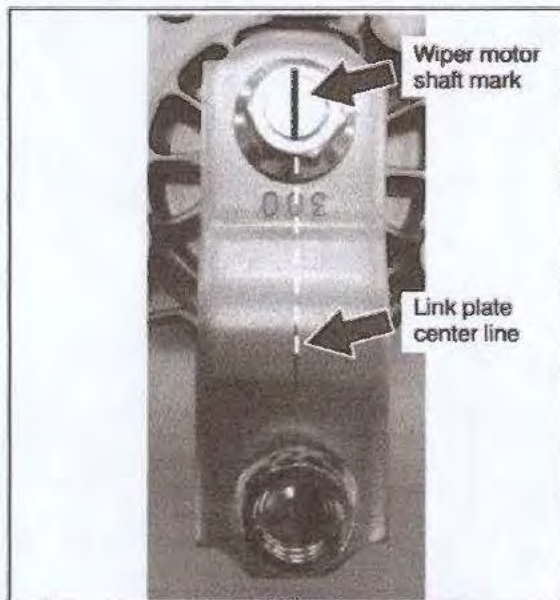

13. Use a straight edge to line up the link plate center line and the center of the wiper motor shaft, and use a marker to create a visible marking on the wiper motor shaft.

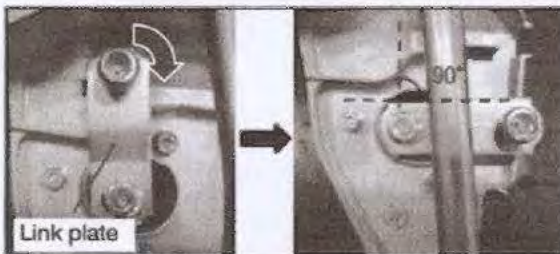

14. Turn the link plate approximately 90 degrees clockwise.



For vehicles with recall SR-16-010 open:

- a. Remove and discard old wiper motor.
- b. Obtain the new countermeasure wiper motor (part # MW400223).
- c. Verify that the new wiper motor has a breathing hole cap with a water proof cloth, as shown.

NOTE: Part # 8250B137 cannot be used on Outlander Sport Windshield Wiper Motor recall.

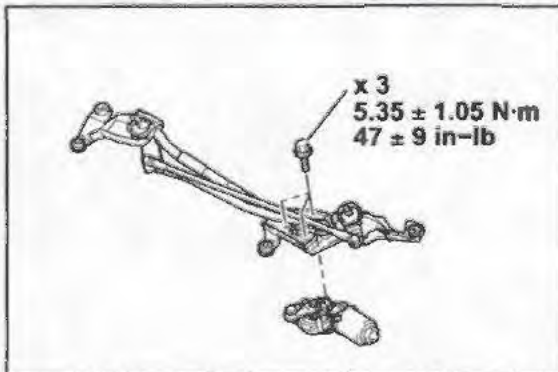

For vehicles with recall SR-16-010 open:

- d. Install the new wiper motor to the wiper link assembly as illustrated, and tighten the 3 bolts to 47 ± 9 in-lb (5.35 ± 1.05 Nm).

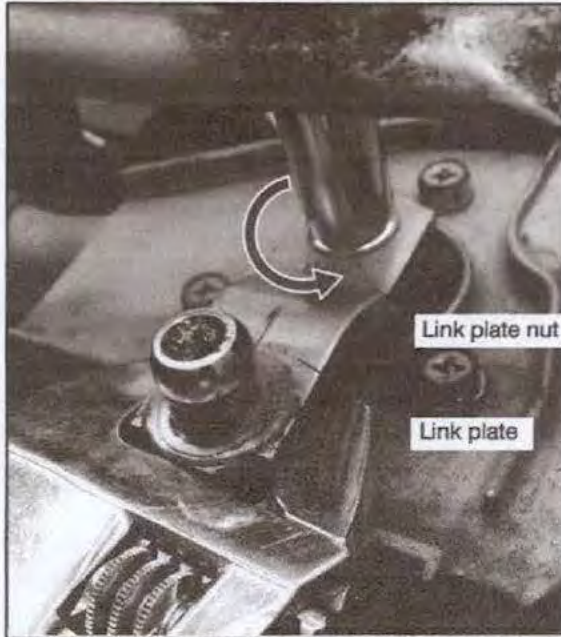

15. Hold the link plate in place with an adjustable wrench while loosening the link plate nut.

16. Remove the link plate and link plate nut.

NOTE: The link plate nut will be reused. Do not discard.



17. Check the knurling on the wiper motor shaft for any damage and/or debris. Clean off any debris with a clean rag.

CAUTION

Clamp the wiper link assembly at the connection pipe only.

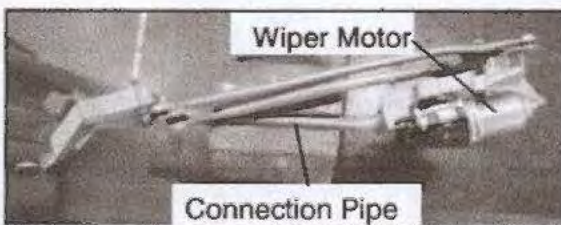

18. Rotate the wiper link assembly 90 degrees upward so that the wiper motor is directly visible from the top.

CAUTION: Clamp **ONLY** the connection pipe section.

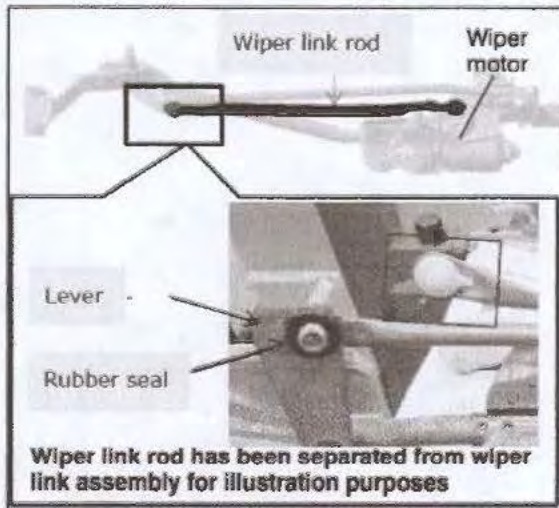

19. Locate the joint to be separated.

CAUTION Do not remove the wiper motor side joint.



20. Pull back the rubber seal to prevent damage when performing the following steps.



21. Use bent needle nose pliers to separate the wiper link rod from the wiper link assembly.

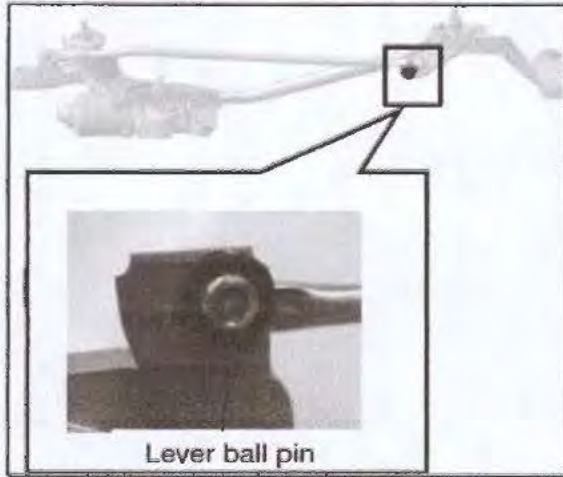

22. Use a rag to clean dirt and grease off of the lever ball pin and rubber seal.

CAUTION Do NOT install link rod assembly if there is presence of water. If there is presence of water, remove excess water and dry thoroughly prior to re-installation.

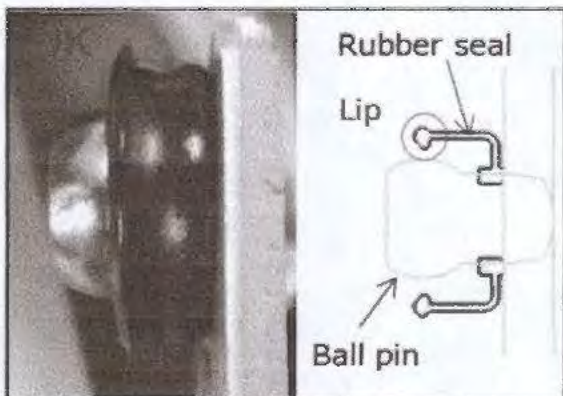

23. Verify that the rubber seal is not damaged. If rubber seal is damaged, replace it with a new rubber seal (part # 8251A098).



24. Rotate the wiper link assembly 90 degrees down so that the motor axle is facing up.

CAUTION: Clamp ONLY the connection pipe section.



- 25. Obtain new wiper link rod (part # 8251A100).
- 26. Verify that the new wiper link rod appears as illustrated, complete with pad and link plate attached.



- 27. Install the wiper link plate to the wiper motor shaft. Make sure that the link plate and wiper link rod are in the correct orientation.

CAUTION Do NOT install link plate in a slanted position.

CAUTION Do NOT damage the pad.

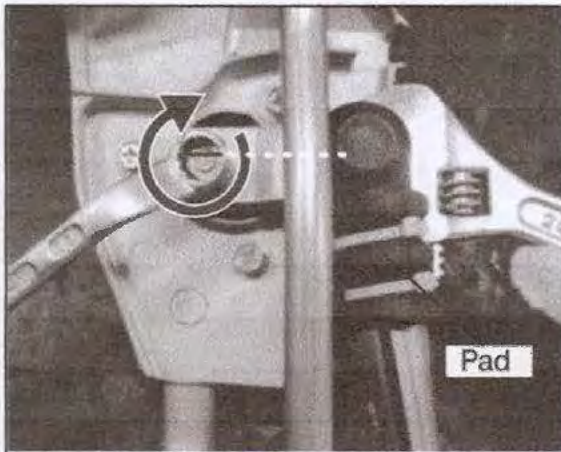

- 28. Make sure that the wiper motor shaft mark and the link plate center line are lined up. Use an adjustable wrench to hold the link plate in position, to prevent link plate rotation. Tighten the nut to 12.5 ft-lb \pm 1 ft-lb (17.2 \pm 1.0 Nm).

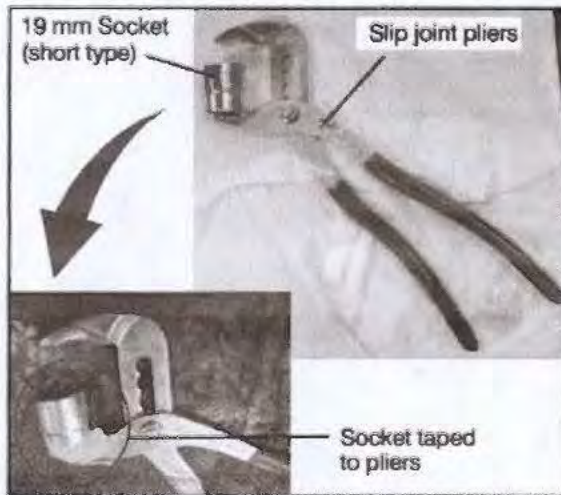

29. To prevent damage to the plastic case, improvise a tool using a 19 mm socket taped to slip joint pliers as shown.

CAUTION

Turn the link plate slowly to avoid internal damage to the wiper motor.

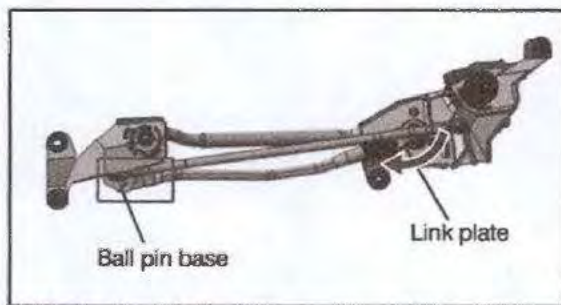

30. Turn the link plate slowly in the direction shown by the red arrow, so that the ball pin's base is visible (for easier installation).

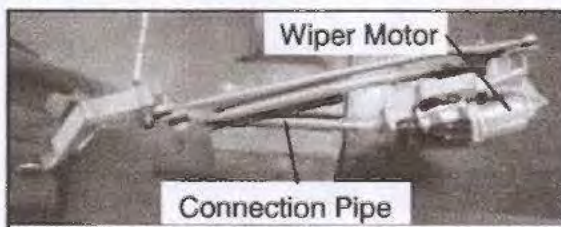

31. Rotate the wiper link assembly 90 degrees upward so that the wiper motor is directly visible from the top.

CAUTION: Clamp ONLY the connection pipe section.

32. Install wiper link rod, using the improvised tool, to the lever end that is opposing the wiper motor.



CAUTION The rubber seal must be properly seated. Confirm good condition of the rubber seal.

33. Verify that the rubber seal is properly seated.

CAUTION Confirm that the plastic case is not damaged or cracked.

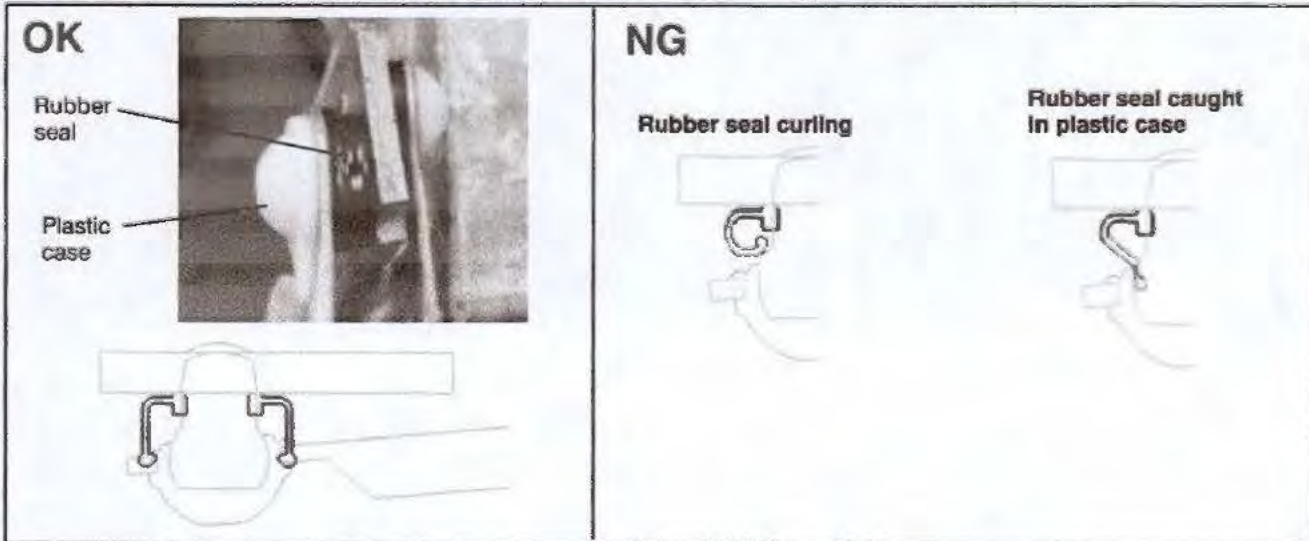

34. Remove the wiper link assembly from the vice.



35. Reinstall the wiper link assembly to the vehicle and connect the windshield wiper motor connector.

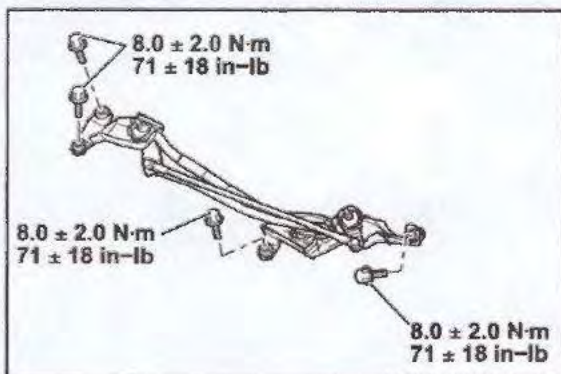

Torque bolts to $71 \pm 18 \text{ in}\cdot\text{lb}$ ($8.0 \pm 2.0 \text{ Nm}$).

WARNING Do not allow any appendages, clothing, or other items to make contact with the wiper link assembly. The wiper may move once the wiper fuse is reinstalled, causing bodily injuries and/or damage to vehicle.

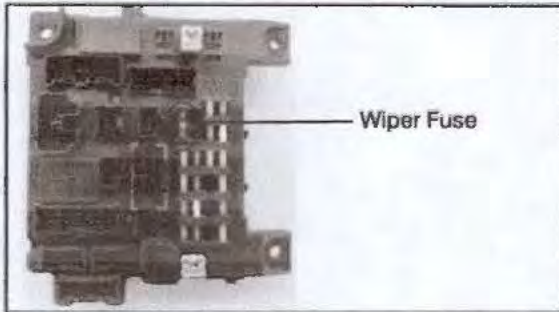

36. Reinstall the Wiper Fuse.

37. Turn the ignition switch to "ACC" or "ON".

38. Switch the windshield wiper switch to "LO" and back to "OFF" to move wiper link to initial position.

39. Remove protective slit hose from windshield.



40. Install the passenger side wiper arm at the marked position.

a. Tighten nut to 20 ± 2 ft-lb (27 ± 3 Nm).



41. Confirm wiper operation in wiper "INT" mode for 10 cycles. If either of the following abnormal behavior is observed, perform the appropriate correction.

a. Abnormal behavior 1: Wiper blade moves up briefly then stops.

(1) Correction procedure: Turn link plate clockwise.

b. Abnormal behavior 2: Wiper blade moves down briefly during the start of wiper operation.

(1) Correction procedure: Turn link plate counterclockwise.

42. Remove the passenger side wiper arm.
43. Reinstall the front deck garnish.
44. Reinstall hood rear passenger side weatherstrip.
45. Reinstall the wiper arm blade assemblies to the marked locations.
46. Tighten nuts to 20 ± 2 ft-lb (27 ± 3 Nm).
47. Verify wiper motor operation by turning the vehicle ignition to "ACC" or "ON" and activate the windshield wipers in "LO" and "HI" positions.
48. Return the Fuse Remover to the fuse box.
49. Close the fuse box lid and hood.

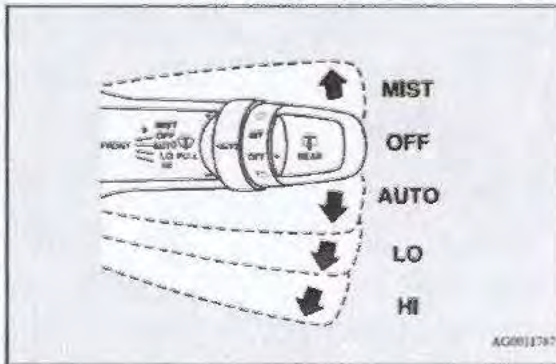

50. Reinstall the passenger compartment fuse lid by lining up the fuse lid hook (A) with the clamp (B) on the instrument panel and push the lid back in.

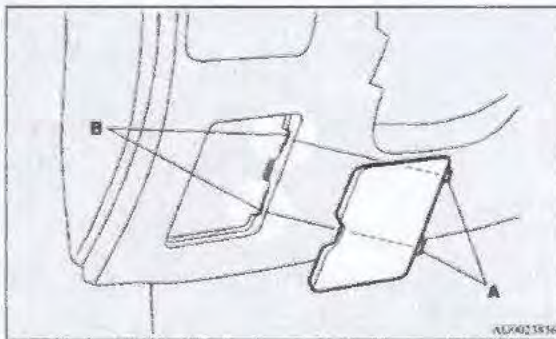

PARTS INFORMATION

Part Number	Part Description
8251A100	WIPER LINK ROD

WARRANTY INFORMATION

#	Repair Procedure	Model Years	Campaign Operation	Labor Time Allowance	Part Number
1	Wiper Link Rod Replacement	2013-2015	C1805Z01	0.7 hours	8251A100
2	Wiper Link Rod Replacement	2011-2012, 2016	C1806Z01	0.7 hours	8251A100

WARRANTY / RECALL CAMPAIGN CLAIM INFORMATION

Enter all claims as claim type 'C' – Recall/Campaign Claims.

Please follow the campaign instructions when entering each claim in order to select the applicable operation code that correctly matches up with the work that was actually performed. A claim example is provided below.

Certain 2011–2016 MY Outlander Sport / RVR models

Claim Header Section:

The screenshot displays the 'Service Warranty' interface. At the top, it says 'MITSUBISHI DEALER LINK' and 'Service Warranty'. Below this, there are tabs for 'Claim Entry', 'Vehicle Information', 'Interface', and 'PQR/VQR'. The 'Campaign Information' section is highlighted, showing fields for 'Campaign Operation No' (C1805Z), 'Miles/Km' (64500), and 'VIN' (JA.....). A callout box points to the 'Campaign Operation No' field with the text: 'Enter in the first 6 characters of the applicable campaign number: C1805Z or C1806Z.' Another callout box points to the 'VIN' field with the text: 'This campaign is for replacing the wiper link. Check the Open Campaign area of the Superscreen each time to be certain of a vehicle's eligibility. Only VINs showing C1805Z or C1806Z as open are involved. Note: All vehicles with open C1611Z or C1612Z must be completed with this recall. The labor times for C1611Z and C1612Z have been adjusted to pay the correct amount of labor to perform the 2 recalls at the same time.' Below the campaign information, there are fields for 'Service Technician', 'Emp #', and 'Service Advisor'. There are also 'Spec Value *' and 'Duplicate Recall *' checkboxes. At the bottom, there are fields for 'Dealer: 99320', 'Ref No:', 'VIN:', 'Claim No:', 'Adj:', 'Claim Status: Incomplete', and 'Model and Year:'. Two buttons, 'Save & Continue' and 'Main Menu', are located at the bottom of the form.

After entering the required customer data, vehicle information, select the applicable campaign number and the one replacement scenario performed. Then, by hitting the "Save and Continue" button, the system will automatically fill—in several fields. See the labor parts examples on the next page.

Labor and Parts

Labor: There is only 1 repair scenario for this campaign - Replace the wiper link.

Replace the wiper link: C1805Z01 or C1806Z01 .7 hrs.

 Parts: The wiper link will be the required part for this recall.

Replace with part number: 8251A100 Rod, Assembly Wiper Link (LHD)

Campaign Claim

Follow the allowed labor time and required parts to be replaced depending on the one specific campaign operation that applies to the specific vehicle. The applicable campaign operation is shown on the Superscreen.

#	Repair Procedure	Model Years	Campaign Operation	Labor Time Allowance	Part Number
1	Wiper Link Rod Replacement	2013-2015	C1805Z01	0.7 hours	8251A100
2	Wiper Link Rod Replacement	2011-2012, 2016	C1806Z01	0.7 hours	8251A100

Rental Cars and/or Towing Charges:

If there is a need to provide the owner with a rental car, claim the applicable charges in this section of the claim on the lower portion of the labor entry screen.

Special Sublet Selection

Select	Labor Operation	Labor Operation Description							
<input type="checkbox"/>	SHO	SPECIAL HANDLING ORDER	SHO Parts Order						
<input type="checkbox"/>	RENTACAR	RENTAL CAR CHARGES 	<table border="1"> <thead> <tr> <th>Days</th> <th>Reason</th> <th>Invoice Number</th> </tr> </thead> <tbody> <tr> <td></td> <td></td> <td></td> </tr> </tbody> </table>	Days	Reason	Invoice Number			
Days	Reason	Invoice Number							
<input type="checkbox"/>	95300040	FREIGHT CHARGES	<table border="1"> <thead> <tr> <th>Freight Company</th> <th>Invoice Number</th> </tr> </thead> <tbody> <tr> <td></td> <td></td> </tr> </tbody> </table>	Freight Company	Invoice Number				
Freight Company	Invoice Number								
<input type="checkbox"/>	95200040	TOWING CHARGES	<table border="1"> <thead> <tr> <th>Towing Company</th> <th>Invoice Number</th> </tr> </thead> <tbody> <tr> <td></td> <td></td> </tr> </tbody> </table>	Towing Company	Invoice Number				
Towing Company	Invoice Number								

 MITSUBISHI MOTORS	Mitsubishi Motors North America, Inc. PARTS BULLETIN
SUBJECT: LIFT GATE GAS SPRING CORROSION – SAFETY RECALL CAMPAIGN	No: TS-XX-01-17
	Date: January 17, 2017
	Model: Certain 2011, 2012, 2016 Outlander Sport / RVR

PURPOSE:

This bulletin provides background detail for the lift gate gas springs ("struts") issue on affected vehicles.

The supplier may have applied insufficient anti-corrosion treatment to the outer tube of the lift gate gas spring. The lift gate gas spring provides lifting assistance for the lift gate and operates utilizing high pressure gas. If insufficient anti-corrosion coating is applied to the outer tube of the gas spring, it is possible for the outer tube to corrode over time due to salt and water penetration. If this occurs, it is possible for the gas spring to rapidly lose pressure. If the gas spring rapidly loses pressure, the lift gate may fall down suddenly, causing injury.

Please reference SAFETY RECALL CAMPAIGN BULLETIN **SR-16-011** for repair instructions for this campaign. The recall campaign ID is **C1614Z**.

AFFECTED VEHICLES:

Certain 2011, 2012, 2016 Outlander Sport / RVR

IMPORTANT

Affected new or used inventory vehicles must be repaired before the vehicle is delivered. Dealers must check their inventory vehicles' VINs on the Warranty Superscreen to verify whether the vehicle is involved in this recall campaign. It is a violation of Federal law for a dealer to deliver a new motor vehicle or any new or used item of motor vehicle equipment (including a tire) covered by the notification under a sale or lease until the defect or noncompliance is remedied.

PARTS INFORMATION

PART NUMBER	DESCRIPTION	Quantity
5802A712	TAILGATE STRUT KIT	1



Mitsubishi Motors North America, Inc.
PARTS BULLETIN

SUBJECT:

**LIFT GATE GAS SPRING CORROSION –
SAFETY RECALL CAMPAIGN**

No: TS-XX-01-17

Date: January 17, 2017

Model: Certain 2011, 2012,
2016 Outlander Sport / RVR

PARTS ORDERING AND ALLOCATION INFORMATION:

Dealers can get up to (2) forced allocations depending on in stock vehicles. The first allocation of orders will be for in stock dealer inventory. Part shipments will be processed via the 'R' order type and began shipping on Friday, January 6, 2017. The second allocation of orders will be for expected initial repairs to sold vehicles. These part shipments will begin shipping with stock orders on January 20, 2017. If you receive inquiries from customers of affected vehicles prior to receipt of the second shipment, please keep our "customer first" philosophy in mind and appropriately allocate inventory. Parts are readily available and dealers may place additional orders via the MDL as necessary.

Contact your local Zone Representative, District Parts and Service Manager, or Facing PDC for questions or comments.



Part 573 Safety Recall Report

20V-279

Manufacturer Name : Mitsubishi Motors North America, Inc.

Submission Date : MAY 18, 2020

NHTSA Recall No. : 20V-279

Manufacturer Recall No. : SR-20-003



Manufacturer Information :

Population :

Manufacturer Name : Mitsubishi Motors North America, Inc.

Number of potentially involved : 141,200

Address : 6400 Katella Avenue
Cypress CA 90630

Estimated percentage with defect : 1 %

Company phone : 1-888-648-7820

Vehicle Information :

Vehicle 1 : 2010-2010 Mitsubishi Lancer Sportback

Vehicle Type : LIGHT VEHICLES

Body Style : 4-DOOR

Power Train : GAS

Descriptive Information : Only vehicles manufactured within the specified production dates, and currently or ever registered in the Salt Belt region * are potentially affected by this recall.

*Connecticut, Delaware, Illinois, Indiana, Iowa, Kentucky, Maine, Maryland, Massachusetts, Michigan, Minnesota, Missouri, New Hampshire, New Jersey, New York, Ohio, Pennsylvania, Rhode Island, Vermont, Virginia, West Virginia, Wisconsin, and Washington D.C.

Production Dates : JUN 17, 2009 - JUN 08, 2010

VIN Range 1 : Begin : NR **End :** NR Not sequential

Vehicle 2 : 2011-2016 Mitsubishi Outlander Sport

Vehicle Type : LIGHT VEHICLES

Body Style : 4-DOOR

Power Train : GAS

Descriptive Information : Only vehicles manufactured within the specified production dates, and currently or ever registered in the Salt Belt region * are potentially affected by this recall.

*Connecticut, Delaware, Illinois, Indiana, Iowa, Kentucky, Maine, Maryland, Massachusetts, Michigan, Minnesota, Missouri, New Hampshire, New Jersey, New York, Ohio, Pennsylvania, Rhode Island, Vermont, Virginia, West Virginia, Wisconsin, and Washington D.C.

Production Dates : SEP 02, 2010 - MAY 10, 2016

VIN Range 1 : Begin : NR **End :** NR Not sequential

Vehicle 3 : 2008-2010 Mitsubishi Lancer

Vehicle Type : LIGHT VEHICLES

Body Style : 4-DOOR

Power Train : GAS

Descriptive Information : Only vehicles manufactured within the specified production dates, and currently or ever registered in the Salt Belt region * are potentially affected by this recall.

*Connecticut, Delaware, Illinois, Indiana, Iowa, Kentucky, Maine, Maryland, Massachusetts, Michigan, Minnesota, Missouri, New Hampshire, New Jersey, New York, Ohio, Pennsylvania, Rhode Island, Vermont, Virginia, West Virginia, Wisconsin, and Washington D.C.

Production Dates : JAN 15, 2007 - JUL 06, 2010

VIN Range 1 : Begin :

NR

End : NR

Not sequential

Vehicle 4 : 2008-2013 Mitsubishi Outlander

Vehicle Type : LIGHT VEHICLES

Body Style : 4-DOOR

Power Train : GAS

Descriptive Information : Only L4 Outlander* manufactured within the specified production dates, and currently or ever registered in the Salt Belt region* are potentially affected by this recall.

*Connecticut, Delaware, Illinois, Indiana, Iowa, Kentucky, Maine, Maryland, Massachusetts, Michigan, Minnesota, Missouri, New Hampshire, New Jersey, New York, Ohio, Pennsylvania, Rhode Island, Vermont, Virginia, West Virginia, Wisconsin, and Washington D.C.

Production Dates : OCT 23, 2007 - MAR 28, 2013

VIN Range 1 : Begin :

NR

End : NR

Not sequential

Description of Defect :

Description of the Defect : The inside and outside surfaces of the front cross members used on certain vehicles, if exposed long term to snowmelt water and anti-freezing agents, may corrode due to insufficient performance of the rust protection. Should significant corrosion occur over time, a lower control arm could eventually become detached resulting in loss of vehicle control and a potential collision.

FMVSS 1 : NR

FMVSS 2 : NR

Description of the Safety Risk : Should significant corrosion occur over time, a lower control arm could eventually become detached resulting in loss of vehicle control and a

potential collision.

Description of the Cause : Long term exposure to snowmelt water and anti-freezing agents, combined with insufficient cross member rust protection.

Identification of Any Warning that can Occur : None.

Involved Components :

Component Name 1 : Crossmember

Component Description : CROSSMEMBER, FR AXLE

Component Part Number : MN100292, 4000A367, 4000A387

Supplier Identification :

Component Manufacturer

Name : NR

Address : NR

NR

Country : NR

Chronology :

Provide the chronology of events leading up to the defect decision or test data for the noncompliance decision: On June 20, 2016, Mitsubishi Motors North America, Inc. (MMNA) submitted a Defect Information Report (DIR), NHTSA ID number 16V-458, to NHTSA concerning front suspension cross member corrosion of certain 2002-2007 MY Lancer and certain 2003-2013 MY Outlander vehicles. Mitsubishi Motor Sales of Canada, Inc. (MMSCAN) also submitted a Notice of Defect (NoD) to Transport Canada (TC) concerning the same issue.

On January 18, 2019, Mitsubishi Motors Corporation (MMC) received a defect investigation information request from TC via MMSCAN concerning cross member corrosion of 2008-2017 MY Lancer vehicles sold in Canada, which is a different generation than the recalled Lancer vehicles. MMC began an investigation and analysis.

On February 28, 2019, MMSCAN responded to TC, explaining that the 2008-2017 MY Lancer vehicles were equipped with a different type of cross member from the recalled vehicles and the occurrence ratio of the 2008-2017 MY Lancer vehicles was much lower than that of the recalled vehicles. MMC decided to continue to monitor the field regarding cross member corrosion, including certain Lancer, Outlander and Outlander Sport (called RVR in Canada) vehicles.

In April, 2019, TC opened an Active Defect Investigation concerning cross member corrosion of the 2008 - 2017 MY Lancer/Lancer Sportback, 2008-2015 MY Lancer Evolution, 2008-2013 MY Outlander with a 4-cylinder engine and 2011-2016 MY Outlander Sport vehicles.

From April 2019 to April 2020, MMC continued to monitor the field. MMC also conducted further investigations, analysis, and safety assessment and continued to have ongoing discussions with TC.

On May 11, 2020, although TC has not issued any findings, based on its ongoing monitoring and analysis, MMC determined that a field action was necessary and advised MMNA to conduct the safety recall in the Salt Belt region of the United States.

Description of Remedy :

Description of Remedy Program : Owners of all affected vehicles will be notified and encouraged to bring in their vehicles for inspection. The cross member will be inspected and the following action will be taken at no charge to the customer:

- (1) If no significant corrosion is identified, a sealing/anti-corrosion agent will be sprayed inside/outside the cross member;
- (2) In the event that significant corrosion is identified, the cross member will be replaced with a countermeasure cross member.

Owners seeking reimbursement for any expenses associated with this recall will be directed in the notification letter to contact the Mitsubishi Customer Relations Department for instructions on how to apply for a refund.

How Remedy Component Differs from Recalled Component : The cross member will be replaced with a countermeasure cross member as follows.

- New part number : MW400273, made of Zinc-coated steel sheets
- Old part number : MN100292, 4000A367, 4000A387, made of general steel sheets

Identify How/When Recall Condition was Corrected in Production : The material of the cross member was changed from general steel sheets to Zinc-coated steel sheets which have higher anti-corrosion performance in production in May 2016.

Recall Schedule :

Description of Recall Schedule : MMNA is working internally to determine the dealer and customer notification date and will update accordingly.

Planned Dealer Notification Date : MAY 29, 2020 - MAY 29, 2020

Planned Owner Notification Date : JUL 14, 2020 - JUL 14, 2020

* NR - Not Reported

Exhibit #6



undercarriage corrosion fix refund

1 message

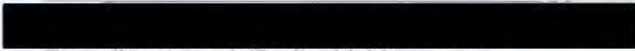

Thu, Oct 7, 2021 at 9:07 AM

To: callcenterweb@mitsubishicars.com

Hi.

In October of 2018, I had all of the parts and labor associated with the undercarriage corrosion fix for my Mitsubishi Outlander Sport 2012 done. At the time, I thought the recall that applied to most of your other vehicles for models in those years would apply, but I was told it would not by both Cape and Islands Mitsubishi and Mitsubishi Corporate.

I have attached the receipt for the services I paid for. It also includes a new manual transmission and various other recalls.

2 weeks ago I brought my car to Cape and Islands Mitsubishi again to get windshield washer reservoir replaced and discovered that the undercarriage corrosion problem is now covered under the latest recall. I'd like to receive a refund for the repairs I paid out of pocket 3 years ago.

Please send my refund check to:

[Redacted]
Braintree, MA [Redacted]

Thank you



--



Sent with Mixmax



Exhibit #7



Thank You Email from Mitsubishi Motors

2 messages

callcenterweb@mitsubishicars.com <callcenterweb@mitsubishicars.com>

Thu, Oct 7, 2021 at 9:17 AM



Thank you for submitting an email to Mitsubishi Motors North America, Inc.! We appreciate your interest in Mitsubishi vehicles, and request your patience as we research your question or comment. You will be receiving a reply as soon as possible. We look forward to serving you. If you have any questions that require immediate attention, please give us a call at 888-648-7820 and mention the following email reference activity number [REDACTED] when you call.

Please note that we can only respond to questions regarding US vehicles through this channel. Should you have a vehicle from another country, please visit www.mitsubishi-motors.com to locate the Mitsubishi Motors distributor closest to you.

Please do not reply to this email, as this email account is not monitored and you will not receive a response. To email Mitsubishi Customer Relations, please visit our website at <https://www.mitsubishicars.com/contact-us>, or you may contact Customer Relations at (888)648-7820, Monday-Friday, 7am-4pm, Central Time. Thank you.

Sincerely,

MMNA Customer Relations

[THREAD ID: [REDACTED]]

— On [REDACTED]
From: [REDACTED]
Sent: 10/7/2021 06:07:32 AM
To: callcenterweb@mitsubishicars.com
Subject: undercarriage corrosion fix refund

Hi,

In October of 2018, I had all of the parts and labor associated with the undercarriage corrosion fix for my Mitsubishi Outlander Sport 2012 done. At the time, I thought the recall that applied to most of your other vehicles for models in those years would apply, but I was told it would not by both Cape and Islands Mitsubishi and Mitsubishi Corporate.

I have attached the receipt for the services I paid for. It also includes a new manual transmission and various other recalls.

2 weeks ago I brought my car to Cape and Islands Mitsubishi again to get windshield washer reservoir replaced and discovered that the undercarriage corrosion problem is now covered under the latest recall. I'd like to receive a refund for the repairs I paid out of pocket 3 years ago.

Please send my refund check to:

[REDACTED]
Braintree, MA [REDACTED]

Thank you
[REDACTED]

—

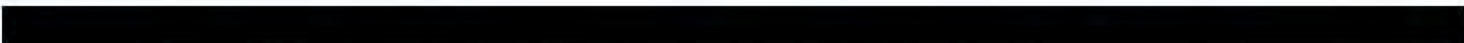

5/1/22, 6:51 PM

Gmail - Thank You Email from Mitsubishi Motors

[REDACTED]

Sent with Mixmax

[REDACTED]

Mon, Oct 11, 2021 at 12:59 PM

Hi.

I'm following up on the issue I submitted below.

Can you please tell me what the status is?

Thanks

[REDACTED]

[Quoted text hidden]

[REDACTED]

Sent with Mixmax

**UNITED STATES
POSTAL SERVICE®**

**PRIORITY
MAIL
EXPRESS®**



1007



20540

U.S. POSTAGE PAID
PME 1-Day
WEST FALMOUTH, MA
02574
MAY 02, 22
AMOUNT

\$26.95

R2305K135327-9



**PRIORITY
MAIL
EXPRESS®**



EJ 922 595

Department of Transportation

W41-306

Building: DOT

Address: 4 West

Routing Symbol: NEC, NOA, NIA

Service: EXPRESS

Date: 5/5/2022 9:37:25 AM



2595561US

FREE SUPPLIES ONLINE



0001000006

EP13F May 2020
OD: 12 1/2 x 9 1/2

E



Braintree, MA

DELIVERY OPTIONS (Customer Use Only)

SIGNATURE REQUIRED Note: The mailer must check the "Signature Required" box if the mailer: 1) Requires the address to be verified; OR 2) Purchases additional insurance; OR 3) Purchases COD service; OR 4) Purchases Return Receipt. If the box is not checked, the Postal Service will leave the item in the addressee's mailbox without attempting to obtain the addressee's signature on delivery.

Delivered next business day
Additional fee, where available
Post Office for availability.

PHONE ()

Way Traffic Safety
Jersey Ave, SE
Washington, DC

9 (U.S. ADDRESSES ONLY)

- For pickup or USPS Tracking™, visit USPS.com or call 800-222-1811.
- \$100.00 Insurance included.

PEEL FROM THIS CORNER

PAYMENT BY ACCOUNT (if applicable)

USPS® Corporate Acct. No.

Federal Agency Acct. No. or Postal Service™ Acct. No.

ORIGIN (POSTAL SERVICE USE ONLY)

<input checked="" type="checkbox"/> 1-Day	<input type="checkbox"/> 2-Day	<input type="checkbox"/> Military	<input type="checkbox"/> DPO
FO ZIP Code 02574	Scheduled Delivery Date (MM/DD/YY) 05/03/2022	Postage WEST FALMOUTH, MA 02574 MAY 2 2022 \$26.95	
Date Accepted (MM/DD/YY) 05/02/2022	Scheduled Delivery Time 6:00 PM	Insurance Fee \$	COD Fee \$
Time Accepted 10.25 AM	Special Handling/Fragile	Return Receipt Fee \$	Leave Addressal Transportation Fee \$
Weight 5.9 lbs.	Sunday/Holiday Premium Fee \$	Total Postage & Fees \$26.95	

DELIVERY (POSTAL SERVICE USE ONLY)

Delivery Attempt (MM/DD/YY)	Time	Employee Signature
	<input type="checkbox"/> AM <input type="checkbox"/> PM	
Delivery Attempt (MM/DD/YY)	Time	Employee Signature
	<input type="checkbox"/> AM <input type="checkbox"/> PM	

LABEL 11-B, MAY 2021

PSN 7690-02-000-9996

GUARANTEED* • TRACKED • INSURED

Braintree, MA

National Highway Traffic Safety Adminis
1200 New Jersey Avenue, SE
Washington, D.C. 20540