

INFORMATION Redacted PURSUANT TO THE FREEDOM OF INFORMATION ACT (FOIA), 5 U.S.C . 552(B)(6)

Safety Issue Type: Complaints

July 12 2017 NHTSA ID Number: 11004762

Components: STEERING

NHTSA ID Number 11004762

Incident Date December 17 2016

Consumer Location WYANDOTTE, MI

Vehicle Identification Number 3CZRU5H30HM*****

Complaint Summary

CRASH No TL* THE CONTACT OWNS A 2017 HONDA HR-V. EVER SINCE THE VEHICLE WAS PURCHASED, THERE HAD BEEN AN ALIGNMENT ISSUE. THE CONTACT STATED THAT IT WAS DIFFICULT TO KEEP THE VEHICLE DRIVING IN THE SAME LANE. THE CONTACT ALSO STATED THAT IF THE STEERING WHEEL WAS NOT SECURELY HELD, THE VEHICLE WOULD PULL TO THE LEFT OR THE RIGHT. THE VEHICLE WAS TAKEN TO VICTORY HONDA (LOCATED AT 1605 N. MONROE STREET, MONROE, MI 48162, TEL: (888)714-7803) TO BE DIAGNOSED. THE CONTACT WAS INFORMED THAT THE VEHICLE OPERATED AS INTENDED. THE VEHICLE WAS ALSO TAKEN TO TWO INDEPENDENT MECHANICS WHO PERFORMED ALIGNMENTS, BUT THE FAILURE RECURRED. THE MANUFACTURER STATED THAT BASED ON THE DIAGNOSTIC TESTING FROM VICTORY HONDA, THE VEHICLE WAS OPERATING AS INTENDED. THE VEHICLE WAS NOT REPAIRED. THE APPROXIMATE FAILURE MILEAGE WAS 1,106.

NOT ACCURATE

Associated Products (1)

Vehicle

MAKE	MODEL	YEAR
HONDA	HR-V	2017

11004762

June 16, 2017

American Honda Motor Co., Inc.

Honda Automobile Customer Service

Mail Stop 500-2N-7A

1919 Torrance Boulevard

Torrance, CA 90501-2746

VIN: 3CZRUSH30HM [REDACTED]

Date of Purchase: 12/02/2016

Current Odometer reading: 3957

[REDACTED]
[REDACTED]
Wyandotte, MI [REDACTED]

Telephone: [REDACTED]

Please refer to enclosed detailed history.

Dealer: Victory Honda of Monroe

1605 N. Monroe St.

Monroe, MI 48162

Copy: Attorney General Bill Schuette

Consumer Protection Division

P.O. Box 30213

Lansing, MI 48909

11/25/2016: Honda New car inquiry/ Sams Club Auto Buying Service

11/29/2016: 2016 Honda HR-V quote Deal # [REDACTED] Victory Honda, Monroe, MI

11/30/2016 2012 Ford Escape, 26,764 miles, offered trade-in allowance of \$10,750.

12/01/2016: Received call from Victory Honda that an HR-V was found in a light color as I had requested, that they would have to pick it up in Tennessee with 800 miles on odometer, and it would be a 2017 at the same price as the 2016.

I agreed and that night Paul from Victory Honda CAME TO MY HOUSE in

Wyandotte (24 miles) for me to sign the purchase papers. Deal # [REDACTED]

There was no opportunity to test-drive the car.

12/02/2016: Received a call late in the day from Victory asking me to fax a copy of my driver's license, auto insurance, and my check # [REDACTED] in the amount of \$10,499.00. Faxed at 5:56 p.m.

Later that evening ("JT") delivered the Honda to my home and took the Ford Escape.

Victory only allowed \$10,700 on the trade in, not the \$10,750 as on the agreement.

12/08/2016: I ordered the Owner's Manual, Navigation Manual, and Warranty Booklet.

Honda touch-up paint was in the glove compartment but not the manuals.

I was informed that on 10/4/2016 Tire and Body work was performed at

Cookeville, TN. prior to this vehicle offered for sale on 10/12/2016.

12/17/2016: I experienced an under-steering condition when I was following a curve in the road

to the left but the vehicle continued moving forward for a few seconds before

responding to the steering. I realized car did not steer forward without veering.

12/18/2016: Car skidded four times on snow. Observed all tire treads caked with snow.

12/23/2016: Sought advice from Mike Kuhn, 36 year owner of Quality Tires in Lincoln Park, MI.

regarding steering, car drifting left, and tires. He recommended snow tires.

12/27/2016: Odometer mileage: 1,106 (I received the car with 800 miles on odometer), Victory

Honda performed a 4-wheel ALIGNMENT to correct pulling to the left and right.

12/28/2016: Quality Tires put proper size Michelin snow tires on front wheels.

02/02/2017: Odometer reading: 1742 miles (Car had 800 miles when received as new.)

Victory Honda performed a SECOND ALIGNMENT as car continued to drift right and left.

03/29/2017: Quality Tires removed the snow tires, put the back tires in front, and the

original front Michelins in back. Per recommendation, I then went to

Horner's Corner Auto Clinic, Inc. , specialists in Front End Alignment.

Mr. Horner said with his experience, he would not do an alignment as he did not believe the problem is in the alignment.

03/30/2017: On recommendation I went to Montie's Service in Allen Park, MI. for another

opinion regarding this safety issue. Mr. Al Montie looked under the car and said he would not do an alignment but recommended that I test drive a different HR-V.

Mr. Montie ran a mapquest and found the mileage from Cookeville Honda (TN) to Victory Honda, Monroe, MI. is 485 miles not the 800 on odometer.

04/10/2017: I went to LaFontaine Automotive Group (Honda) in Dearborn, MI. and test drove

the 2017 Honda HR-V EX with Patrick Cowan, sales consultant. There was NO PULL whatsoever in our test drive with this Honda. Mr. Cowan stated they didn't want to get involved with the issues on my HR-V.

04/11/2017: Mileage: 2,900 (I received this vehicle with 800 miles on odometer.) Victory Honda of

Monroe performed a third alignment to correct the left and right drifting.

04/25/2017: I returned to Victory Honda of Monroe due to safety concerns as the car continued

drifting. This time I was not given a copy of the Work Order but was given a copy of the Current Measurements that indicates no need for an alignment.

05/30/2017: Mileage: 3680. Belle Tire, Southgate, MI test drove the car and recommended

Left front, Right front, and Right rear corrections on an alignment.

Belle Tire crossed both front tires. I declined the \$89.99 alignment at this time.

Belle Tire recommended that I go to Genthe Honda to have the car inspected under the frame.

05/30/2017: Genthe Honda, Southgate, MI, Jeff Nicora test drove the car and observed a pull into the right lane within 6 seconds of pulling out of the dealership, and consistently right and left throughout the test drive. Jacqui Grimes, Service Mgr. said I would have to pay the \$80.00 for an alignment regardless of the warranty of "Wheel alignment covered for the first year or 12,000 miles." She recommended that I call Victory Honda service manager, Jim Galofaro at 734.775-2053.

05/31/2017: I called Honda Customer Service due to my frustration and was given Case # [REDACTED]

06/07/17: Finally spoke with "Jose" who said to me "WHAT DO YOU WANT ME TO DO ABOUT IT?" I asked him "WHAT DO YOU WANT ME TO DO?...GET AN ALIGNMENT EVERY TIME I WANT TO GO OUT?" (Sorry, I thought I was calling Customer SERVICE.) He said he would call Genthe to do the alignment as it IS under warranty and "maybe it wasn't done right at Victory Honda."

06/12/2017: Genthe Honda service tech test drove the car despite my insistence that I be in the car. Jeff Nicora, Service, was well aware of my request as I specifically mentioned it when I brought the car in. I also asked from the waiting area a couple times repeating "I want to go for the test drive." "Where's the car?"

On the Inspection Report it states Customer states..."and is all over the road".

That is not my terminology. My complaint was "Pulling left or right" and the understeering. Genthe Honda is claiming that what I experience is normal.

The service manager was more concerned with two small wheel scratches.

06/13/2017: Received call from Honda Customer Service reiterating information as reported by Jacquie Grimes of Genthe Honda. I indicated unacceptance due to the fact that I have

06/13/2017 con't.:

owned numerous vehicles and have never experienced problems as I have with this vehicle. I have no violations or accidents on my driving record, have owned numerous automobiles and now fear for the safety of myself and others with this vehicle.

6/14/2017: As recommended by Genthe service department, I test drove another 2017 HR-VEX.

(Mr. Mazi Khan, Sales). This vehicle responded as did the HR-V I test drove on April 10th and was a pleasure to drive.

Thank you for your attention to this matter.

[REDACTED]

Wyandotte, MI [REDACTED]

Phone: [REDACTED]

All copies included.



HEARING CONFIRMATION

Customer

[Redacted]

Wyandotte, MI [Redacted]

Manufacturer

American Honda Motor Co., Inc.
American Honda Motors, Co, Inc.
1919 Torrance Blvd.
Torrance, CA 90501

Arbitrator(s)

Sandra Franklin

Case #: [Redacted]
Vin #: 3CZRUSH30HM [Redacted]

Dear Parties:

This is to confirm the following hearing arrangements:

Hearing Date: 07/20/2017
Hearing Time: 10:00 AM EST
Hearing Location: Hotel / Conference Center, **Please see receptionist for room location**
Address: Holiday Inn Southgate
17201 Northline Rd
Southgate, MI 48195
Hearing Phone: 734-283-4400

Thank you for your consideration in scheduling and keeping this appointment. PLEASE NOTE: The hearing will be conducted in English. If you require an interpreter, it is your responsibility to arrange for an interpreter to attend the hearing with you. **Please be prepared to proceed with any of your witnesses or other evidence including bringing your vehicle to the hearing for inspection.** Also be prepared to show valid proof of current automobile insurance and your driver's license should the Arbitrator, or one or more of the Arbitrators, request a test drive. Please contact NCDS immediately in the event that circumstances necessitate a change of hearing date or time.

For the Arbitrator(s)

July 5, 2017

Date

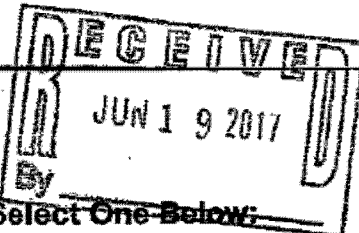

Select One Below:

Documents Only Hearing
In Person Oral Hearing

American Honda Motor Co., Inc.
Customer Claim Form

FOR NCDS USE
CASE NUMBER: [REDACTED]

CUSTOMER NAME AND ADDRESS

Mr. First name [REDACTED] MI [REDACTED] Last name [REDACTED]
 Mrs. Street address [REDACTED]
 Ms.
City WYANDOTTE State MI Zip Code [REDACTED]
Day phone [REDACTED] Evening phone SAME Email [REDACTED]

VEHICLE INFORMATION

Name(s) that appears on the vehicle title: [REDACTED]
Is this a leased vehicle: Yes No Delivery Date: 12/02/2016
Was this vehicle purchased used? Yes No Is vehicle used by a business? Yes No % of use _____
Make: HONDA Model: HRV-LX Year: 2017 Current mileage: 3957
Vehicle Identification Number: 3CZRUSH30HM [REDACTED]
Selling dealer and address: VICTORY HONDA OF MONROE
1605 N. MONROE ST., MONROE, MI 48142
Dominant Servicing Dealer: VICTORY HONDA OF MONROE - MONROE, MI
GENTHE HONDA - SOUTHGATE, MI

VEHICLE PROBLEM(S) (Attach legible copies of applicable repair orders or other documents that support your complaint)

Problem	List dealer(s) which have repaired or attempted repair (include city & state).	List the date, mileage, and repair order number for each repair attempt.	Does the problem currently exist? (Circle)	
Example: A/C won't cool properly	Autoworld, Inc Anytown, VA	4/23/99 3,500 miles #B73540	Yes	No
<u>RIGHT AND LEFT DRIFTING</u>	<u>VICTORY HONDA</u> <u>MONROE MI</u>	<u>11/06 1742, 2900</u> <u>12/27/16 2/2/17 4/11/17</u>	<u>(YES)</u>	No
	<u>GENTHE HONDA</u> <u>SOUTHGATE MI</u>	<u>6/12/17 3908 MILES</u>	<u>(YES)</u>	No
	<u>BELLE TIRE #32</u> <u>SOUTHGATE MI</u>	<u>5/30/17</u> <u>3680 MILES</u>	<u>(YES)</u>	No
			Yes	No
			Yes	No

Has the vehicle been involved in an accident? YES NO
If YES, give date of accident: _____ Specify damaged area: _____

Resolution Sought:

Repurchase Replacement HRV-EX
Repair Reimbursement

Return all copies of this form to:
National Center for Dispute Settlement
P.O. Box 1108
Mt. Clemens, MI 48046



VICTORY HONDA

of Monroe

BUYER		SALES- INFORMATION	
Guest		Deal#:	[REDACTED]
		Deal Date:	11/30/2016
		Print Time:	7:21 pm
		Salesperson:	Unassigned

VEHICLE INFORMATION		
<input checked="" type="checkbox"/> New	Stock#:	VIN:
<input type="checkbox"/> Used	Description: 2016 Honda HR-V 2WD 4dr Wgn LX AT AT [RU5H3GEW]	
<input type="checkbox"/> Certified Pre-Owned	Mileage: 0	

PRICE		TRADE	
MSRP:	\$20,915.00	Vehicle:	
Discount:	\$944.26	VIN:	Allowance: \$10,750.00
Adjusted Sale Price:	\$19,970.74	Mileage:	Payoff: \$0.00
Sales Price Sub-Total:	\$19,970.74		
Trade Allowance:	\$10,750.00		
Difference:	\$9,220.74	Total Trade Allowance:	\$10,750.00
Trade Payoff:	\$0.00	Total Trade PayOff:	\$0.00
Rebate:	\$0.00		
Balance Forward:	\$9,220.74		
(before taxes, title, license and fees)			

WHICH PAYMENT WORKS BEST FOR YOU ?	
Option 1 - Own	
Out of Pocket →	\$10,499.42
<u>Term</u>	
0 Mos	\$0.00

This is an initial customer proposal. The figures presented are based on estimates. Rates subject to credit approval.

Signature: _____ Date: _____ Accepted By: _____



2012 Ford Escape
Trade in 11515-
Market High 12990
List 13877

7.11 242-2300

Faxed to Victory Honda
734-242-8287
12/2/2014 5:56pm *

MICHIGAN REGISTRATION

Ruth Johnson
Secretary of State

Plate: [REDACTED] Expires: [REDACTED]

2012 FORD STA WGN

Vehicle No.: 1FMCU0D74CK [REDACTED] Fee Cat. or Wt.: 24

County: WAYNE

WYANDOTTE MI [REDACTED]

License Fee: 98.00

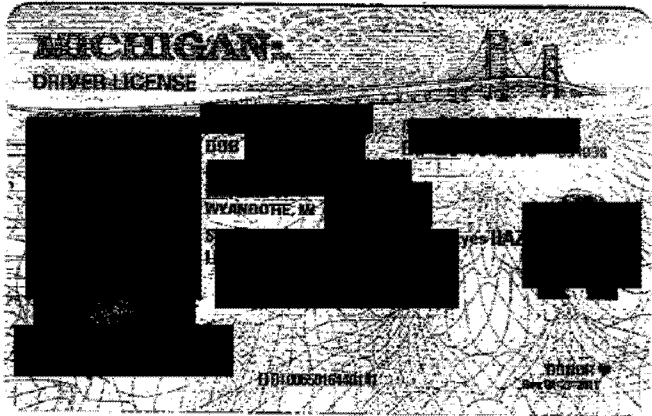

In quietness
and in confidence
shall be your
strength.
Isaiah 30:15

Taylor, MI

Dec 2 2016

Pay to the Order of VICTORY HONDA OF MERRICK \$ 10,499.00

Ten thousand four hundred ninety nine and 00/100 Dollars

DOWNRIVER COMMUNITY FCU

HP Photosmart 7520 Series

Fax Log for

Dec 02 2016 5:57PM

Last Transaction

vehicle.

Date	Time	Type	Station ID	Duration	Pages	Result
Dec 2	5:56PM	Fax Sent	7342428287	0:42	1	OK

Policy Number

Effective Date

Expiration Date

Year

Make / Model

Vehicle ID Number

Agent Name

DZIADZIOLA, MARGARET

To report a claim, contact your agent at 734-284-9500 or call the Home Office at 1-877-324-6764.

NOTICE: This certificate is not a guarantee that the policy is in effect or will remain in effect. The stated dates apply only if the premium due is paid by the established due dates(s) and only so long as the policy is not cancelled for conditions as stated in the policy.

This certificate may be presented as evidence of insurance with your application for license plates at any Secretary of State license plate branch office or mailed with your application.

STATE OF MICHIGAN
CERTIFICATE OF TITLE

VEHICLE IDENTIFICATION NUMBER 3CZRU5H30H [REDACTED]
YEAR 2017 MAKE HONDA MODEL HR-V BODY STYLE STA-WAGON
TITLE NUMBER [REDACTED] ISSUE DATE 12/21/2016 ODOMETER 000800
WEIGHT/FEE CATEGORY 20 ODOMETER BRAND [REDACTED]
ACTUAL MILEAGE

OWNER(S) NAME AND ADDRESS
[REDACTED]
WYANDOTTE MI [REDACTED]



NO SECURED INTEREST ON RECORD

MICHIGAN REGISTRATION

Plate: [REDACTED]
TRANSFER REGISTRATION Expires: 09/10/2017
2017 HONDA STA WGN
Vehicle No.: 3CZRU5H30H [REDACTED]

RUTH JOHNSON
Secretary of State

Fee Cat. or Wt.: 000020
County: WAYNE

State and federal laws require the seller(s) to indicate liability fines and/or imprisonment. ANY ALTERATION

I warrant that the ownership of the vehicle described herein is as stated above.
Printed Name of Purchaser(s)
Purchaser's Street Address
I (we) certify that the odometer reading is: actual mileage not actual mileage
Signature of Seller(s)
X
Seller's Street Address

Completed by Buyer
I am aware of the above odometer certification and agree to pay a \$15.00 late fee.
Signature of Purchaser(s)
X
NEW LIENHOLDER INFORMATION: The assignor of this title is the assignor of the security interest.
Secured Party: [REDACTED] Address: [REDACTED]
Licen 1066.03

12202016 TC E355 603 1630



The State of Michigan hereby certifies that the above described vehicle was subject to the security interest(s) listed on the face proof of ownership. Further, on the date of this issuance, the described vehicle was subject to the security interest(s) listed on the face proof of ownership.

MAILING ADDRESS
[REDACTED]
WYANDOTTE MI [REDACTED]

****NOTICE TO SELLERS****
Sellers must keep a receipt or photocopy of the reassigned title for their records for 18 months or accompany the purchaser to a Secretary of State Office.



11004762

Name
 Address
 Telephone
 Vehicle (VIN)
 License
 Year: 16
 Technician
 Mileage
 Time Printed

16

12/27/16 3:36 PM

Honda : HR-V : Front Wheel Drive : 2016

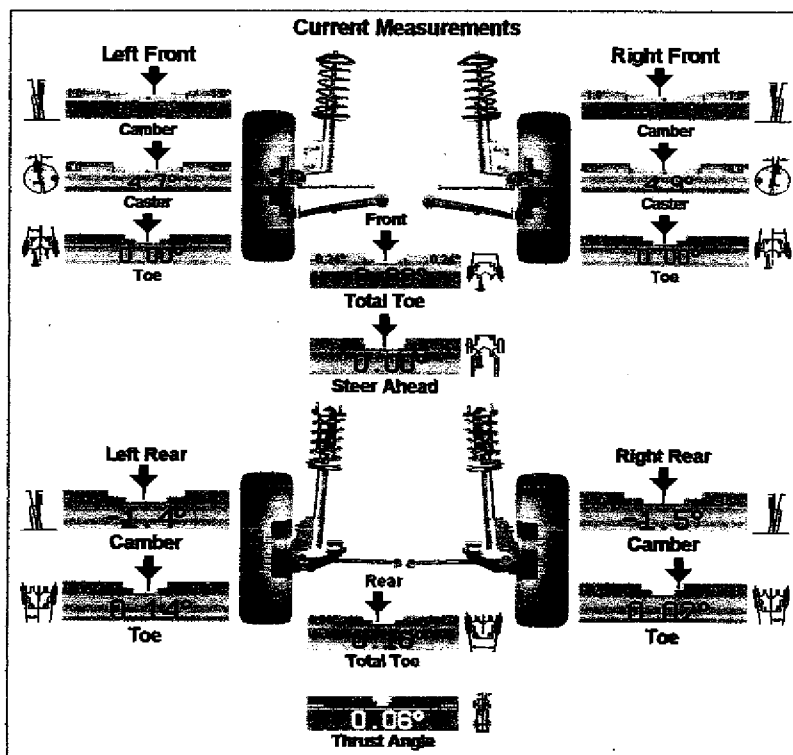
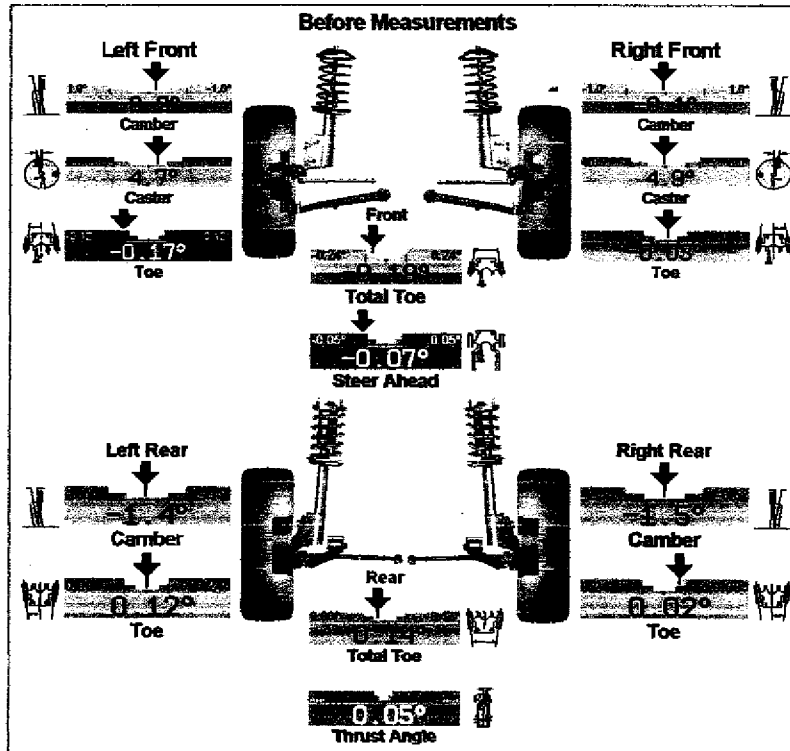

11004762

Warranty Florida



1. Monroe Street • Monroe, Michigan 48162 • (734) 242-2300 • 877 MY HONDA • Fax (734) 242-2332

State Reg. No. F-151450
P & A Code A2291

OWNER NO.	ADVISOR WARREN SCAIFE	2199	TAB NO. 2616	INVOICE DATE 12/27/16	INVOICE NO.
	LABOR RATE	LICENSE NO.	MILEAGE 1,106	COLOR WHT ORCHID	STOCK NO.
	YEAR / MAKE / MODEL 17/HONDA/HR-V/4DR SUV LX 2WD CVT	DELIVERY DATE 12/01/16	DELIVERY MILES 800	SELLING DEALER NO.	PRODUCTION DATE
WYANDOTTE, MI	VEHICLE I.D. NO. 3CZRUSH30HM	R.O. DATE 12/27/16			
REFERENCE PHONE	BUSINESS PHONE	COMMENTS			

MO: 1106

JOB# 1 CHARGES

LABOR
03H0739 FOUR WHEEL ALIGN TECH(S):2001 INTERNAL
PERFORM FOUR WHEEL ALIGNMENT
CAR IS DRIFTING TO THE LEFT CHECK ALIGNMENT AND ADVISE
4 WHEEL ALIGNMENT COMPLETE

*Warren in passenger seat
Verified by R pulling*

JOB# 1 TOTALS
JOB# 1 JOURNAL PREFIX HOCS JOB# 1 TOTAL 0.00

JOB# 2 CHARGES

LABOR
16-103: ECU SW Update Emissions
RECALL
LABOR OP 3115A0/A/B
TECH(S):1505 WARRANTY

JOB# 2 TOTALS
JOB# 2 JOURNAL PREFIX HOCS JOB# 2 TOTAL 0.00

JOB# 3 CHARGES

LABOR
00H0710 FREE 27 PT INSPECT TECH(S):2001 WARRANTY
PERFORM FREE 27 POINT INSPECTION COMPLETE

JOB# 3 TOTALS
JOB# 3 JOURNAL PREFIX HOCS JOB# 3 TOTAL 0.00

JOB# 4 CHARGES

LABOR
00H0710 FREE CAR WASH TECH(S):2001 WARRANTY
FREE CAR WASH

JOB# 4 TOTALS
JOB# 4 JOURNAL PREFIX HOCS JOB# 4 TOTAL 0.00

ESTIMATE
CUSTOMER HEREBY ACKNOWLEDGES RECEIVING ORIGINAL ESTIMATE OF \$0.00 (+TAX)
TECHNICIAN CERTIFICATION
1505 STEPHEN CARPENTER M168557

THE INFORMATION CONTAINED HEREIN IS THE PROPERTY OF HONDA MOTOR CO., LTD. AND IS LOANED TO YOU BY THE SELLING DEALER. IT IS TO BE USED ONLY FOR THE REPAIRS SPECIFICALLY LISTED HEREON. IT IS NOT TO BE REPRODUCED OR TRANSMITTED IN ANY FORM OR BY ANY MEANS, ELECTRONIC OR MECHANICAL, INCLUDING PHOTOCOPYING, RECORDING, OR BY ANY INFORMATION STORAGE AND RETRIEVAL SYSTEM. WITHOUT THE WRITTEN PERMISSION OF HONDA MOTOR CO., LTD. © 2016 HONDA MOTOR CO., LTD.

TERMS are cash on delivery. ESTIMATES ARE FOR LABOR ONLY. MATERIAL IS EXTRA. Storage will be charged 48 hours after repairs are completed. Not responsible for loss or damage to cars or articles left in cars in case of fire, theft, freezing, accident or any other cause beyond our control. An express garagekeeper's lien is hereby acknowledged on above car or truck to secure the amount of repairs thereto.

All repairs and parts listed were furnished in compliance with the Michigan Motor Vehicle Service and Repair Act.

X
THE ONLY WARRANTIES APPLYING TO THIS PART(S) ARE THOSE WHICH MAY BE OFFERED BY THE MANUFACTURER. THE SELLING DEALER HEREBY EXPRESSLY DISCLAIMS ALL WARRANTIES, EITHER EXPRESS OR IMPLIED, INCLUDING ANY IMPLIED WARRANTIES OF MERCHANTABILITY OR FITNESS FOR A PARTICULAR PURPOSE AND NEITHER ASSUMES NOR AUTHORIZES ANY OTHER PERSON TO ASSUME FOR IT ANY LIABILITY IN CONNECTION WITH THE SALE OF THIS PART(S) AND/OR SERVICE. BUYER SHALL NOT BE ENTITLED TO RECOVER FROM THE SELLING DEALER ANY CONSEQUENTIAL DAMAGES, DAMAGES TO PROPERTY, DAMAGES FOR LOSS OF USE, LOSS OF TIME, LOSS OF PROFITS, OR INCOME OR ANY OTHER INCIDENTAL DAMAGES.

SHOP SUPPLIES: 15% OF THE TOTAL LABOR COST IS INCLUDED (MAXIMUM \$25.00) FOR SHOP SUPPLIES USED ON YOUR VEHICLE. APPLICABLE SUPPLY ITEMS ARE: NUTS, BOLTS, WASHERS TAPES PINS APPROPRIATE SHEET AC

Name
Address

Telephone
Vehicle (VIN)
License
Year:
Technician
Mileage
Time Printed

16

2/2/17 8:09 AM

Honda : HR-V : Front Wheel Drive : 2016

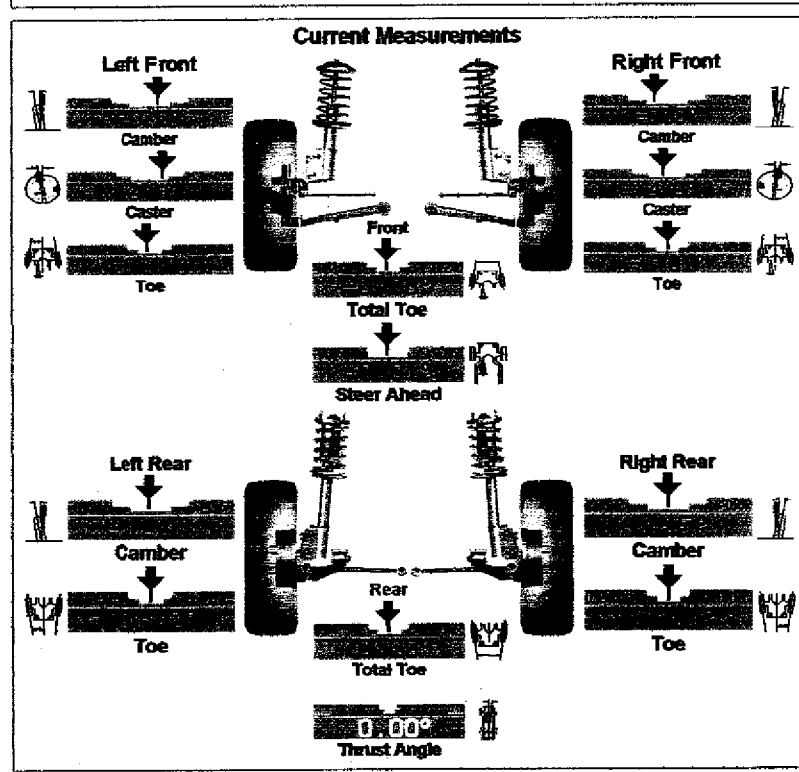
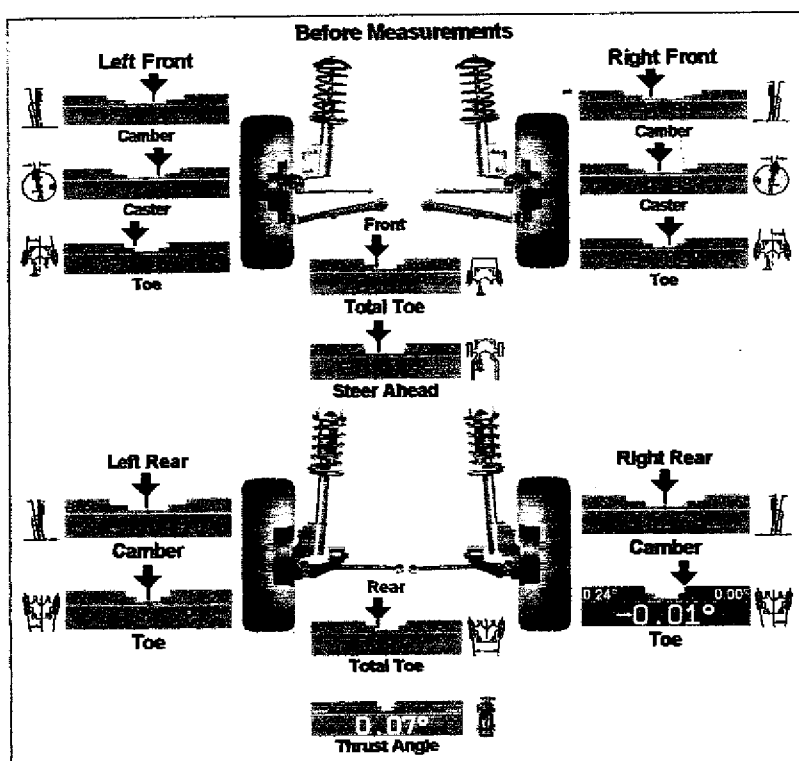

11004762

Victory Florida



1605 N. Monroe Street • Monroe, Michigan 48162 • (734) 242-2300 • 877 MY HONDA • Fax (734) 242-2332

State Reg. No. F-151450
P & A Code A2291

CUSTOMER NO.	ADVISOR CHRISTOPHER MICHEA	TAG NO. 2408 641	INVOICE DATE 02/02/17	INVOICE NO.
	LABOR RATE	LICENSE NO.	MILEAGE 1,742	COLOR WHT ORCHID
RESIDENCE PHONE	BUSINESS PHONE	COMMENTS	DEALER CODE	AUTHORIZATION NUMBER
			MO: 1742	COMMITMENT NUMBER
WYANDOTTE, MI	YEAR / MAKE / MODEL 17/HONDA/HR-V/4DR SUV LX 2WD CVT		DELIVERY DATE 12/01/16	DELIVERY MILES 800
	VEHICLE I.D. NO. 3CZRU5H30HM		SELLING DEALER NO.	PRODUCTION DATE
	F.T.E. NO.	P.O. NO.	R.O. DATE 02/02/17	

JOB# 1 CHARGES

LABOR	TECH(S): 2001	INTERNAL
PERFORM FOUR WHEEL ALIGNMENT C/S THAT THIS IS HER SECOND TIME BACK FOR ALIGNMENT ITS PULLING TO THE (RIGHT) REAL BAD 4 WHEEL ALIGNMENT COMPLETE		
JOB# 1 TOTALS	JOB# 1 JOURNAL PREFIX HOCS	JOB# 1 TOTAL 0.00

Car pulled to left

JOB# 2 CHARGES

LABOR	TECH(S): 2001	INTERNAL
PERFORM FREE 27 POINT INSPECTION COMPLETE		
JOB# 2 TOTALS	JOB# 2 JOURNAL PREFIX HOCS	JOB# 2 TOTAL 0.00

JOB# 3 CHARGES

LABOR	TECH(S): 2001	INTERNAL
FREE CAR WASH INOP DO TO IT IS 32 DEGREES OUTSIDE OR LESS WILL OPEN BACK UP WHEN TEMPTURES ARE ABOVE FREEZING HAVE A GREAT DAY THANK YOU FOR YOUR BUSINESS		
JOB# 3 TOTALS	JOB# 3 JOURNAL PREFIX HOCS	JOB# 3 TOTAL 0.00

ESTIMATE CUSTOMER HEREBY ACKNOWLEDGES RECEIVING ORIGINAL ESTIMATE OF \$0.00 (+TAX)

COMMENTS: WAITER

DEALER CODE: [] AUTHORIZATION NUMBER: [] COMMITMENT NUMBER: []

(CHECK (X) APPROPRIATE BOX)

CLAIMS REVIEW AUTHORIZATION TO SUBMIT CLAIMS PARTS SCRAP OUT

PA CODE: []

DEALER PARTS CUSTOMER WELT ORIGINAL EST. PARTS & LABOR AUTHORIZED SHOP REPAIRS SHOP REPAIRS DATE TIME

ON BEHALF OF SERVING DEALER, I HEREBY CERTIFY THAT THE INFORMATION CONTAINED HEREON IS ACCURATE UNLESS OTHERWISE SPECIFIED. SERVICES DESCRIBED WERE PERFORMED AT NO CHARGE TO OWNER. THERE WAS NO ACCIDENT FROM THE OPERATION OF THE VEHICLE OR IN ANY WAY WITH ANY ACCIDENT. PLEASE USE THESE RECORDS TO SUPPORT THE CLAIMS AVAILABLE FOR 10 YEARS FROM THE DATE OF PAYMENT NOTIFICATION AT THE SERVING DEALER FOR INSPECTION BY CERTIFIED TECHNICIANS OF PDFA.

TERMS are cash on delivery. ESTIMATES ARE FOR LABOR ONLY. MATERIAL IS EXTRA. Storage will be charged 48 hours after repairs are completed. Not responsible for loss or damage to cars or articles left in cars in case of fire, theft, freezing, accident or any other cause beyond our control. An express garagekeeper's lien is hereby acknowledged on above car or truck to secure the amount of repairs thereto.

All repairs and parts listed were furnished in compliance with the Michigan Motor Vehicle Service and Repair Act.

X

THE ONLY WARRANTIES APPLYING TO THIS PART(S) ARE THOSE WHICH MAY BE OFFERED BY THE MANUFACTURER. THE SELLING DEALER HEREBY EXPRESSLY DISCLAIMS ALL WARRANTIES, EITHER EXPRESS OR IMPLIED, INCLUDING ANY IMPLIED WARRANTIES OF MERCHANTABILITY OR FITNESS FOR A PARTICULAR PURPOSE AND NEITHER ASSUMES NOR AUTHORIZES ANY OTHER PERSON TO ASSUME FOR IT ANY LIABILITY IN CONNECTION WITH THE SALE OF THIS PART(S) AND/OR SERVICE. BUYER SHALL NOT BE ENTITLED TO RECOVER FROM THE SELLING DEALER ANY CONSEQUENTIAL DAMAGES, DAMAGES TO PROPERTY, DAMAGES FOR LOSS OF USE, LOSS OF TIME, LOSS OF PROFITS, OR INCOME OR ANY OTHER INCIDENTAL DAMAGES.

SHOP SUPPLIES: 15% OF THE TOTAL LABOR COST IS INCLUDED (MAXIMUM \$25.00) FOR SHOP SUPPLIES USED ON YOUR VEHICLE. APPLICABLE SUPPLY ITEMS ARE: NUTS, BOLTS, WASHERS, TAPE, PINS, AEROSPRAY, SHELLAC,

Printed by Reynolds and Reynolds Company BRANDT/BIUM C0719236 C (03/14)

**QUALITY TIRES
NEW & USED INC.**
4145 Fort St.
Lincoln Park, Michigan 48146
(313) 383-2272

SOLD BY	DATE
[REDACTED]	12/28/16
NAME	
[REDACTED]	
USED MACHINERY	
22155517	100
SALES	6
TRE	5/06
RECEIVED BY: <i>I Am Starting</i>	

All claims and returned goods MUST be accompanied by this bill.
*YOUR OTHER THANKS
You*

**QUALITY TIRES
NEW & USED INC.**
4145 Fort St.
Lincoln Park, Michigan 48146
(313) 383-2272

SOLD BY	DATE
[REDACTED]	3/28/17
NAME	
[REDACTED]	
LABOR	
8:30	
MC	
RECEIVED BY	

All claims and returned goods MUST be accompanied by this bill.
*Thank
You*

MONTIE'S
SERVICE

3/20/17

AUTO REPAIR

Monday Thurs Friday 8:00am until 5:00 pm
Saturday by Appointment Only

19029 Ecorse Road • Allen Park Michigan 48101

Al Montie *Test Drive another* Tel: (313)928-1630
Eric Viger *Honda* Fax: (313)928-1631

Telephone:
734-283-3554



Specializing in
Front End Alignment,
Brakes and Exhaust

Horner's Corner Auto Clinic, Inc.

ALL WORK GUARANTEED
COMPLETE RADIATOR SERVICE
TUNE-UP, GREASE, OIL, FILTER

8:00am - 5:00pm
Monday-Friday

901 Ford Avenue
Wyandotte, MI 48192

LaFontaine
Family Deal.com

Patrick Cowan
Sales Consultant

LaFontaine Automotive Group
AWD 1200 +
HRV EX 2100 +
Main: 313.565.5100
Direct: 248.429.9772
Fax: 313.561.5609
pcowan@LaFontaine.com
2245 S. Telegraph Rd.
Dearborn, MI 48124

4/10/17
www.thefamilydeal.com

Phone
Vehicle (VIN)
License
Year:
Technician
Mileage
Time Printed

4/11/17 10:49 AM

Honda : HR-V : Front Wheel Drive : 2016

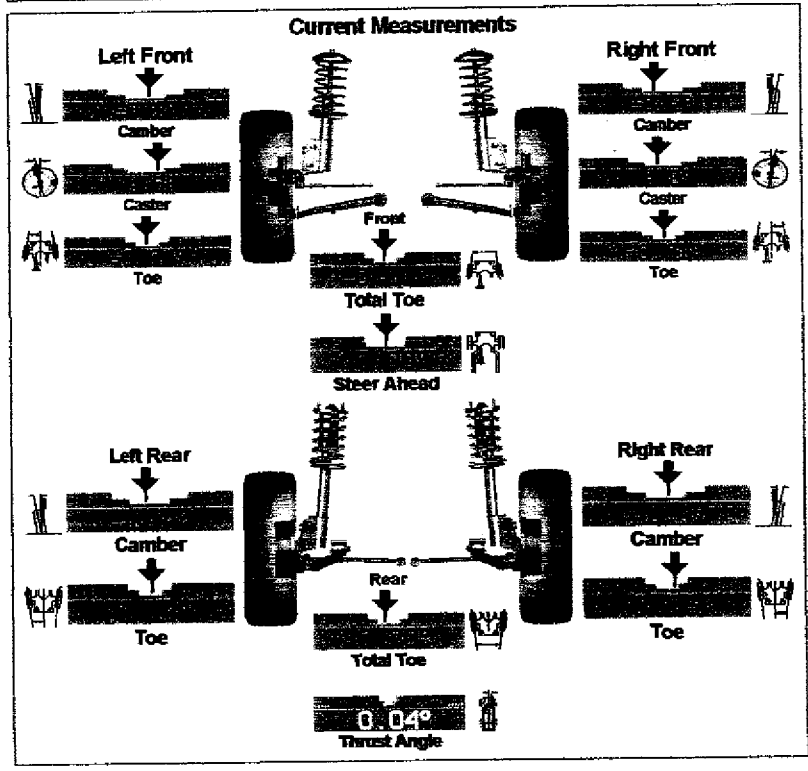
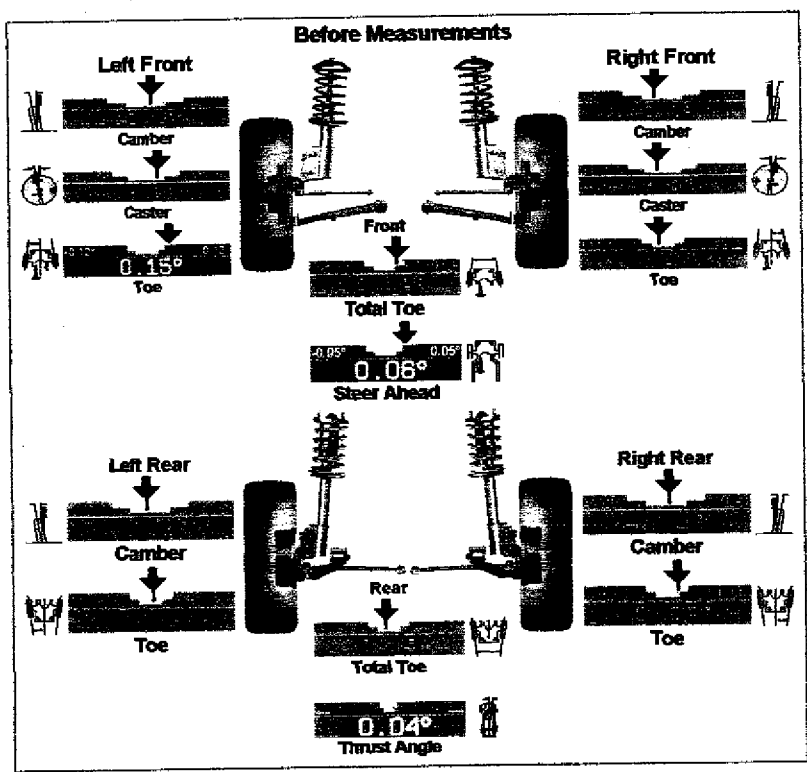

11004762

Victory Florida



1605 N. Monroe Street • Monroe, Michigan 48162 • (734) 242-2300 • 877 MY HONDA • Fax (734) 242-2332

State Reg. No. F-151450
P & A Code A2291

CUSTOMER NO.	ADVISOR WARREN SCAIFE	TAG NO. 2199	WAIT	INVOICE DATE 04/11/17	INVOICE NO.
	LABOR RATE	LICENSE NO.	MILEAGE 2,900	COLOR WHT ORCHID	STOCK NO.
	YEAR / MAKE / MODEL 17/HONDA/HR-V/4DR SUV LX 2WD CVT			DELIVERY DATE 12/01/16	DELIVERY MILES 800
WYANDOTTE, MI	VEHICLE I.D. NO. 3CZRU5H30HM			SELLING DEALER NO.	PRODUCTION DATE
	F.T.E. NO.	P.O. NO.		R.O. DATE 04/11/17	
RESIDENCE PHONE	BUSINESS PHONE	COMMENTS			

MO: 2900

JOB# 1 CHARGES

LABOR

CUSTOMER STATES THAT THE VEHICLE IS STILL PULLING. 3 TIME HAVING ALIGNMENT DONE. CHECK/ADVISE ON REPAIRS NEEDED. CAR IS PULLING TO THE LEFT AND RIGHT. CUSTOMER JUST HAD SNOW TIRES REMOVED. TECH FOUND CAR TO HAVE SLIGHT TOE AND STEER AHEAD COMPLETE CORRECTED AND TEST DROVE

JOB# 1 TOTALS

JOB# 1 JOURNAL PREFIX HOCS JOB# 1 TOTAL 0.00

ESTIMATE
CUSTOMER HEREBY ACKNOWLEDGES RECEIVING ORIGINAL ESTIMATE OF \$0.00 (+TAX)

TOTALS

- *****
- * [] CASH [] CHECK CK NO. []
 - * [] VISA [] MASTERCARD [] DISCOVER
 - * [] AMER XPRESS [] OTHER [] CHARGE
- *****

TOTAL LABOR.... 0.00
 TOTAL PARTS.... 0.00
 TOTAL SUBLET... 0.00
 TOTAL G.O.G.... 0.00
 TOTAL MISC CHG. 0.00
 TOTAL MISC DISC 0.00
 TOTAL TAX..... 0.00

TOTAL INVOICE \$ 0.00

THANK YOU FOR YOUR BUSINESS!!

CUSTOMER SIGNATURE

DEALER CODE	AUTHORIZATION NUMBER	COMMITMENT NUMBER
(CHECK (X) APPROPRIATE BOX)		
<input type="checkbox"/> CLAIMS REVIEW	<input type="checkbox"/> AUTHORIZATION TO SUBMIT CLAIMS	<input type="checkbox"/> PARTS SCRAP CUT
\$ PARTS	\$ LABOR	\$ TOTAL
Authorized Signature and Date		
DEALER PARTS	CUSTOMER REC.	TECHNICIAN SIGNATURE
		AUTHORIZED ADJ. REPAIRS
		DATE TIME
<small>ON BEHALF OF SERVING DEALER, I HEREBY CERTIFY THAT THE INFORMATION CONTAINED HEREON IS ACCURATE UNLESS OTHERWISE SHOWN. SERVICES DESCRIBED WERE PERFORMED AT NO CHARGE TO OWNER. THERE WAS NO INDICATION FROM THE APPEARANCE OF THE VEHICLE OR IN ANY WAY WITH ANY ACCIDENT, NEGLIGENCE OR MISUSE RECORDS SUPPORTING THIS CLAIM ARE AVAILABLE FOR (1) YEAR FROM THE DATE OF PAYMENT NOTIFICATION AT THE SERVING DEALER FOR INSPECTION BY REPRESENTATIVES OF FORD.</small>		
(EXEMPT) DEALER GENERAL MANAGER OR AUTHORIZED PERSON (DATE)		
TERMS are cash on delivery, ESTIMATES ARE FOR LABOR ONLY, MATERIAL IS EXTRA. Storage will be charged 48 hours after repairs are completed. Not responsible for loss or damage to cars or articles left in cars in case of fire, theft, freezing, accident or any other cause beyond our control. An express garagekeeper's lien is hereby acknowledged on above car or truck to secure the amount of repairs thereto.		
<small>All repairs and parts listed were furnished in compliance with the Michigan Motor Vehicle Service and Repair Act.</small>		
X		
THE ONLY WARRANTIES APPLYING TO THIS PART(S) ARE THOSE WHICH MAY BE OFFERED BY THE MANUFACTURER. THE SELLING DEALER HEREBY EXPRESSLY DISCLAIMS ALL WARRANTIES, EITHER EXPRESS OR IMPLIED, INCLUDING ANY IMPLIED WARRANTIES OF MERCHANTABILITY.		

Name
Address

Telephone
Vehicle (VIN)
License
Year:
Technician
Mileage
Time Printed

16

4/11/17 11:18 AM

Honda : HR-V : Front Wheel Drive : 2016

11004762

2 of 2

4/11/17

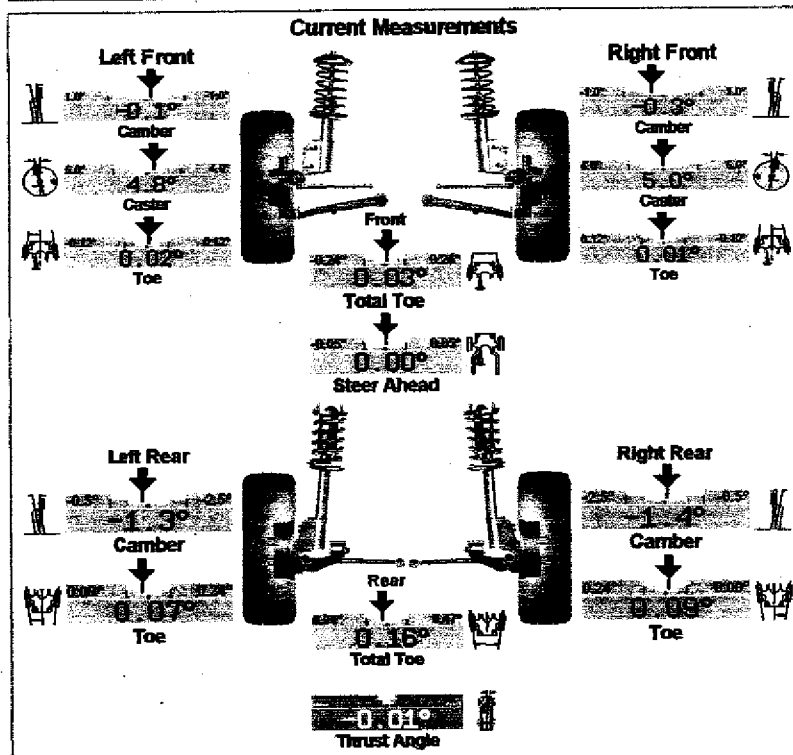
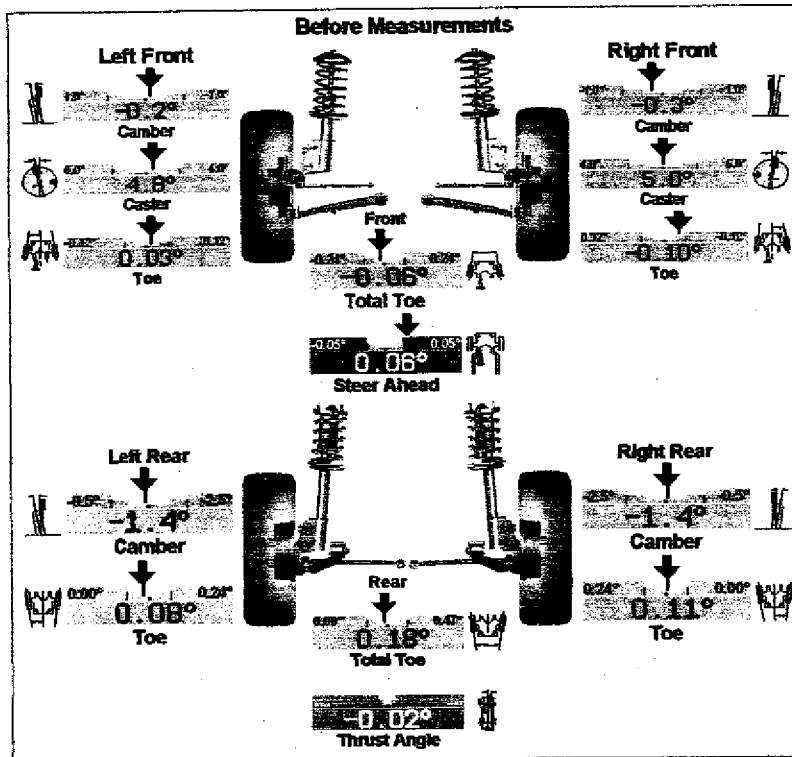

11004762

Name
Address
Telephone
Vehicle (VIN)
License
Technician
Mileage
Time Printed

4/25/17 10:42 AM

Honda : HR-V : Front Wheel Drive : 2016-17

*Victory Honda
did not provide
copy of work order
or of
Before Measurements*

Current Measurements

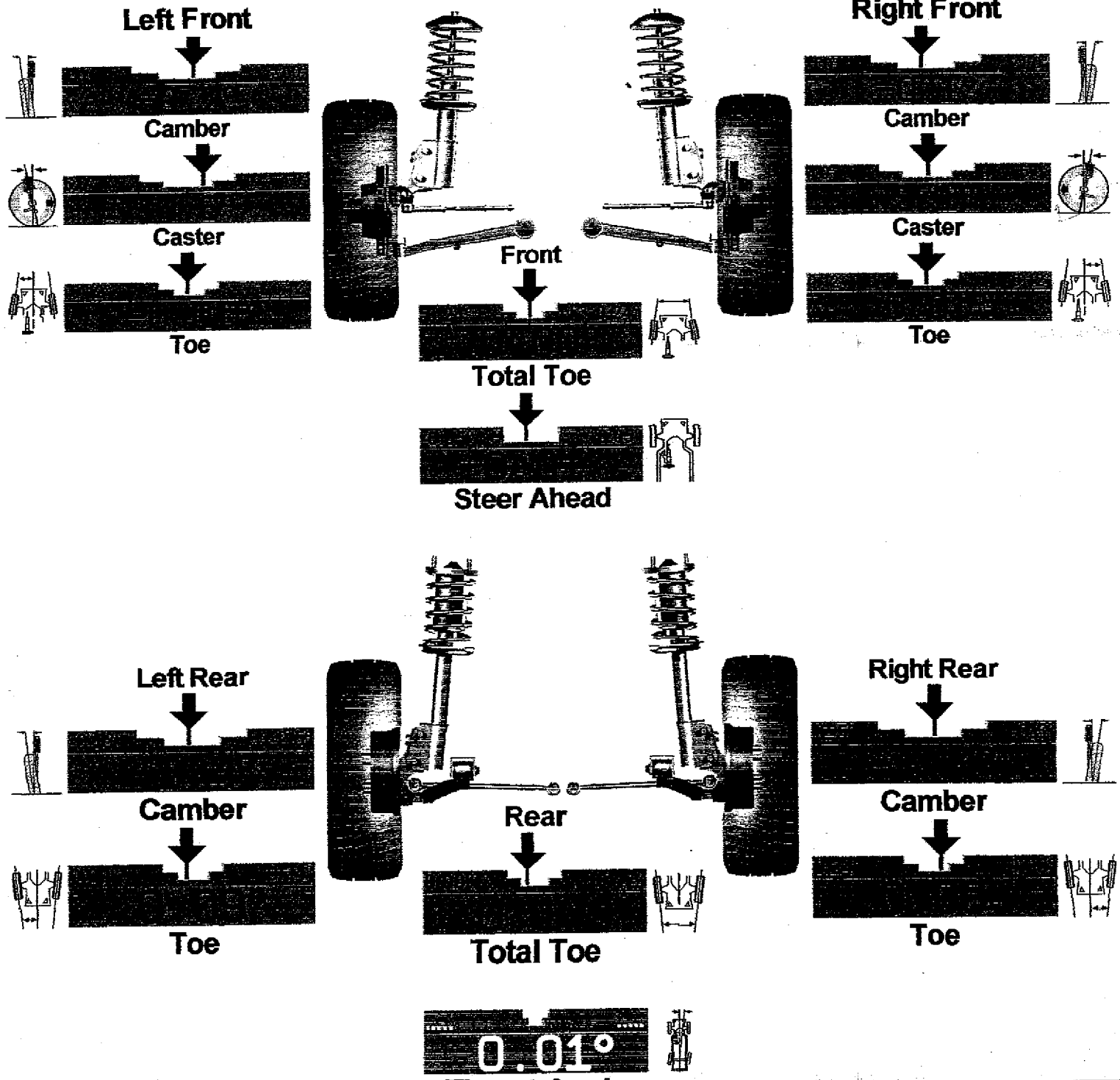

0.01°

11004262

BELLE TIRE #37

Date 5/30/17 3:23 PM

Honda : HR-V : Front Wheel Drive : 2016-17

Front : Left

Actual	Before	Specified Range
		-1.0° 1.0°
		4.0° 6.0°
0.15°		-0.12° 0.12°
13.1°		
13.0°		

Front : Right

Actual	Before	Specified Range
		-1.0° 1.0°
		4.0° 6.0°
-0.14°		-0.12° 0.12°
12.9°		
12.7°		

Camber
Caster
Toe
SAI
Included Angle
Turning Angle Diff.

Front

Cross Camber
Cross Caster
Cross SAI
Total Toe
Cross Turn Diff.

Actual	Before	Specified Range
		-1.0° 1.0°
0.2°		
0.2°		
		-0.24° 0.24°

Rear : Left

Actual	Before	Specified Range
		-2.5° -0.5°
0.20°		0.00° 0.24°

Rear : Right

Actual	Before	Specified Range
		-2.5° -0.5°
-0.06°		0.00° 0.24°

Camber
Toe

Rear

Cross Camber
Total Toe
Thrust Angle

Actual	Before	Specified Range
		-0.8° 0.8°
		0.00° 0.47°
0.13°		

11004762

4-wheel alignment 89.99
front alignment 69.99



BELLE TIRE RECEIPT

Store #37

15555 EUREKA ROAD - SOUTHGATE MI 48195
(734) 282-7300 - FACILITY REG. NO. F148027

Salesperson JONATHAN T. KROHN

Customer Information

Customer # [REDACTED]
Home Phone [REDACTED]
Work Phone [REDACTED]

WYANDOTTE, MI [REDACTED]

Vehicle Information

2017 HONDA TRUC HR-V
Plate # [REDACTED] Vehicle # [REDACTED]
Odometer 3680.0
VIN #: 3CZRU5H30HM [REDACTED]

Order

[REDACTED]
Date: 5/30/2017
Time: 15:52
Last Prt: 5/30/2017 14:23
Last Usr: JOT

Comments: CUSTOMER DECLINED ALIGNMENT AT THIS TIME BECAUSE STILL PULLING TO THE RIGHT.

Product Descriptions and Notations	Quantity	Unit Price	Amount	Mech Tech
1 AW CA CHECK ALIGNMENT PULLING TO RIGHT	1.00	0.00	0.00	JW5
3 AW MISC MISC MECHANIC LABOR CROSSED BOTH FRONT TIRES	1.00	0.00	0.00	JW5

Terms: C.O.D. ONLY

Total Labor:	0.00
Total Parts:	0.00
Other:	0.00
Sales Tax:	0.00
Invoice Total:	\$0.00
Balance Due:	\$0.00

Mechanics / Technician

JW5 - JEFFREY R WELLS M167391

Certification: All repairs and parts listed were furnished in compliance with the Michigan Auto Repair Act (P.A. 300).

Merchandise and/or services received by:

5/30/2017

Print Full Name

Date

X

X

ALL PARTS ARE NEW UNLESS OTHERWISE STATED. YOU ARE ENTITLED BY LAW TO THE RETURN OF ALL PARTS REPLACED, EXCEPT THOSE WHICH ARE TOO HEAVY OR LARGE, AND THOSE REQUIRED TO BE SENT BACK TO THE MANUFACTURER OR DISTRIBUTOR BECAUSE OF WARRANTY WORK OR AN EXCHANGE AGREEMENT. YOU ARE ENTITLED TO INSPECT THE PARTS WHICH CANNOT BE RETURNED TO YOU.

Current Measurements

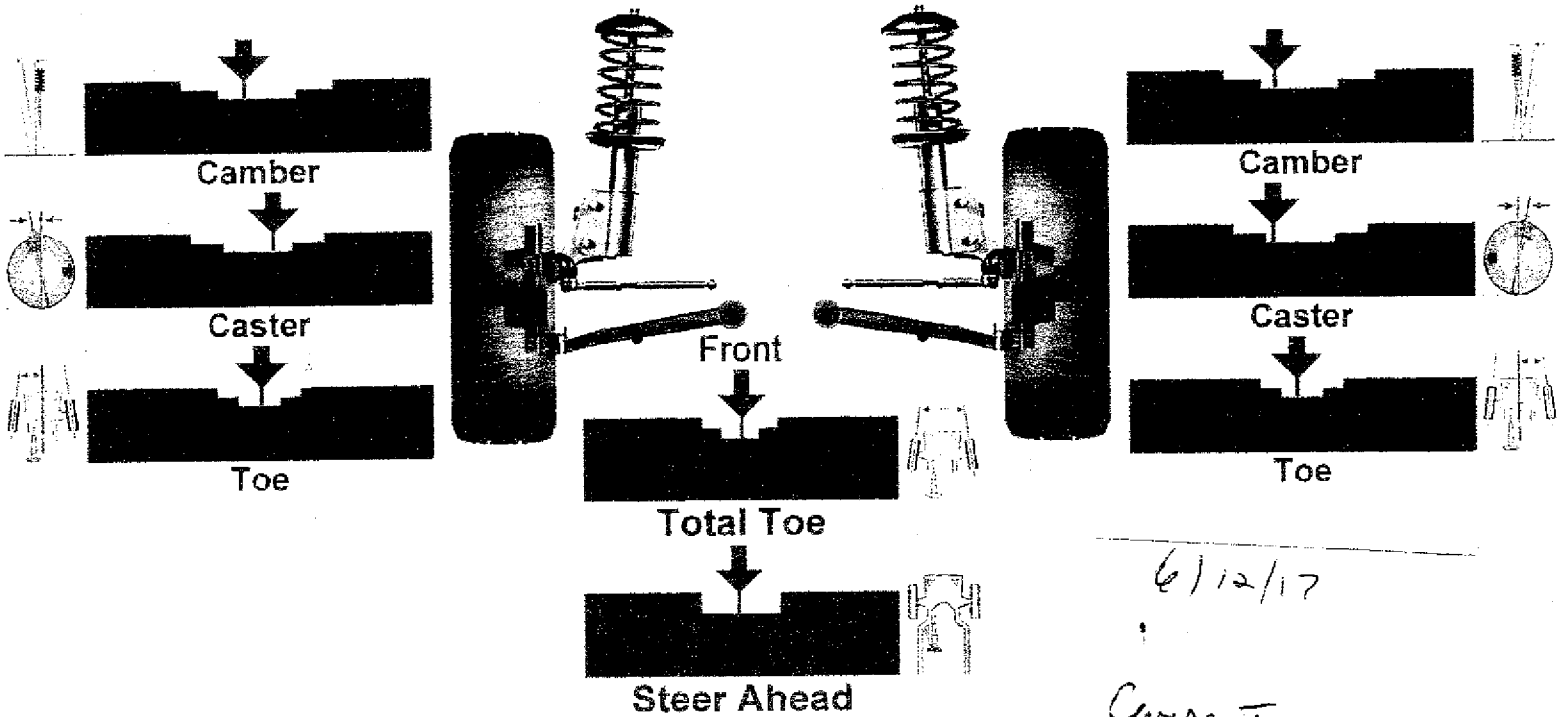

6/12/17

Current Measurements #102

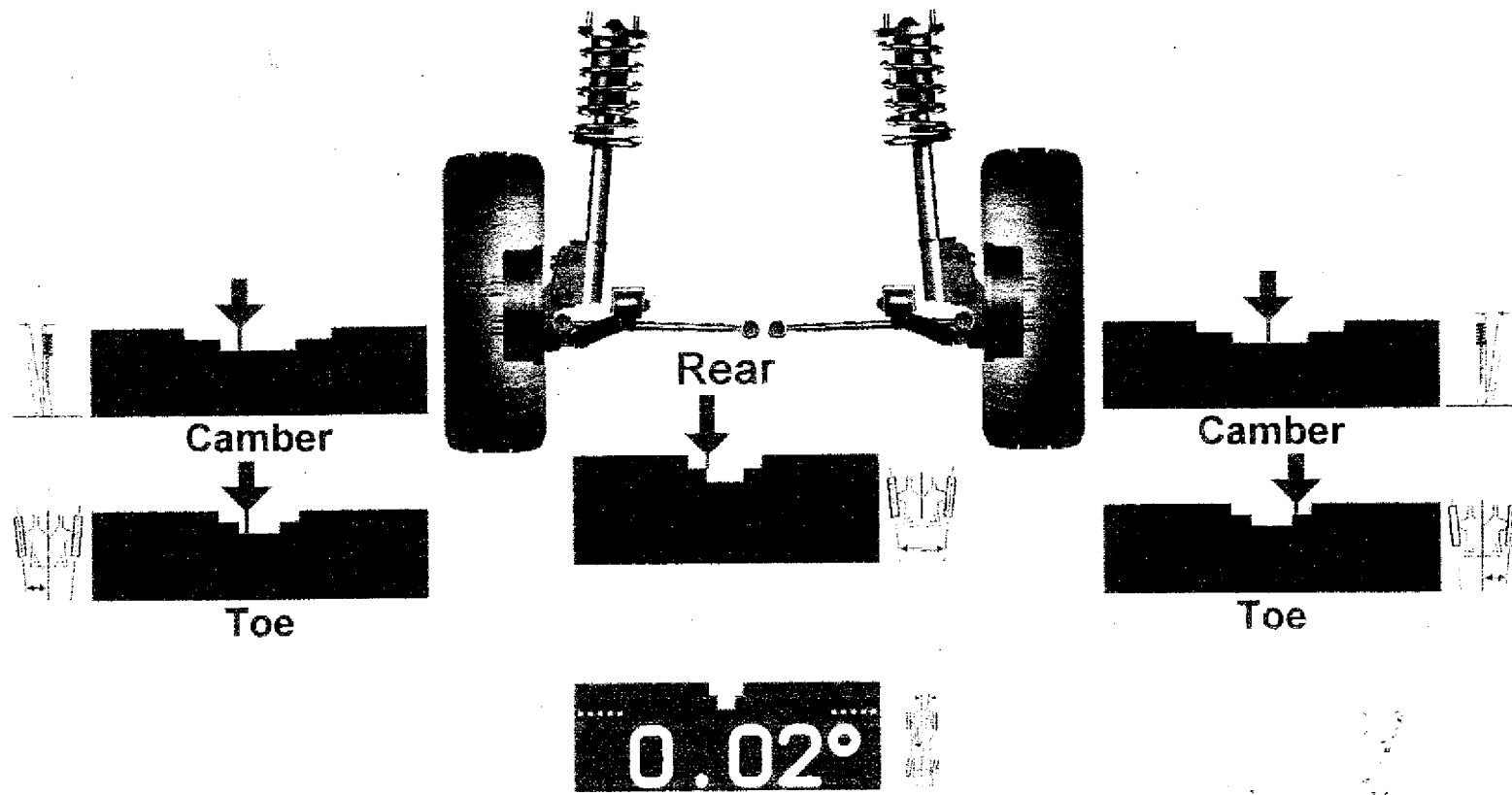

Current Measurements

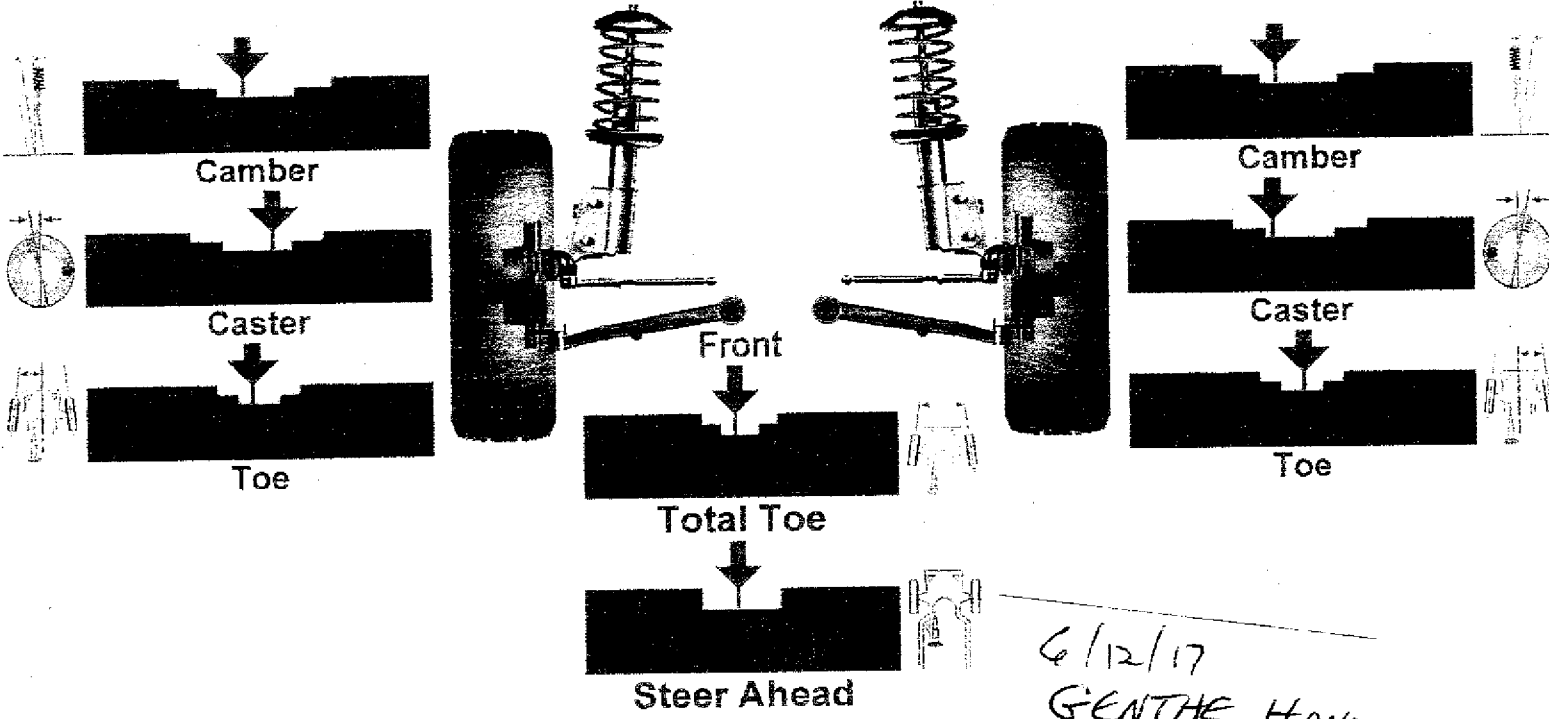

6/12/17
 GENTHE HOND
 Current
 measurements
 # 2 of 2

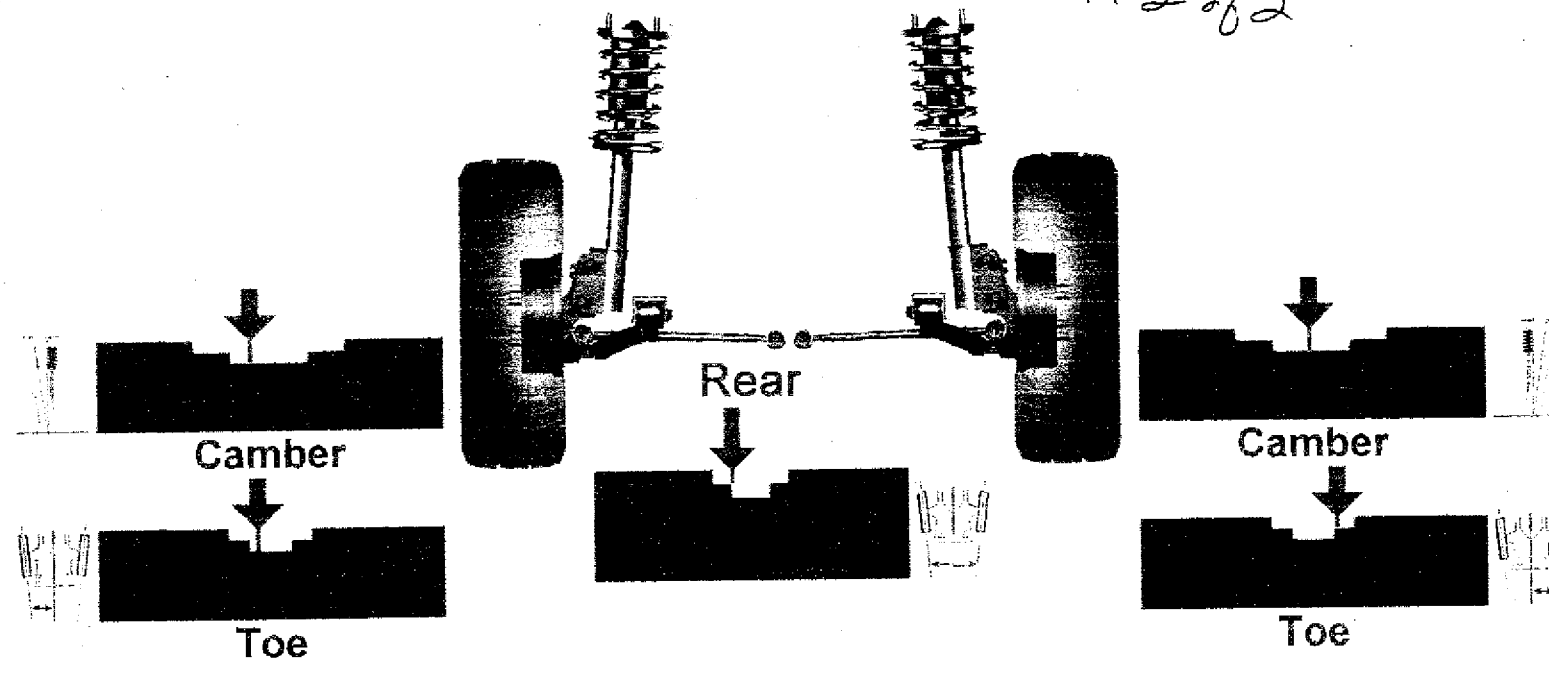

0.02°

3908
 mileage

INVOICE

Invoice #:



Genthe Honda

15100 Eureka Road
Southgate, MI 48195
(734) 283-2600

State Registration No. F-165196

Tag #: T.345.

Bus:

Customer #

Service Advisor: 185 JEFFREY W NICORA

Email:

OTTE, MI

YEAR	MAKE/MODEL	VIN	LICENSE	MILEAGE IN	MILEAGE OUT		
17	HONDA HR-V	3CZRU5H30HM		3901	3908		
PROD. DATE	WARR. EXP.	PROMISED	PG. NO.	RATE	INV. DATE	R.O. OPENED	READY
17		20:00 12JUN17		105.95	CASH	12JUN17	16:01 12JUN17 19:19 12JUN17

ENG: 1.8 Liter

Parts, and Shop Hours
and Thursday
am - 8:00pm
Wednesday
Friday
am - 6:00pm
Saturday
1 - 2:00pm

LINE OPCODE TECH TYPE HOURS LIST NET TOTAL

A CUSTOMER STATES VEHICLE PULLS RIGHT WHILE DRIVING NOT EVEN 20 FT AND THEN PULLS LEFT CUSTOMER HAS HAD MULTIPLE ALIGNMENTS AND STILL VEHICLE PULLS AND IS ALL OVER THE ROAD CHECK AND ADVISE CAUSE: OPERATING WITHIN MANUFACTURER'S SPECIFICATIONS AT THIS.

06 STEERING/SUSPENSION
378 REIMEL, ROBERT LIC#: M160401
CPES

PARTS: 0.00 LABOR: 0.00 OTHER: 0.00 TOTAL LINE A: 0.00

PERFORMED VISUAL INSPECTION AND FOUND DAMAGE ON RIGHT FRONT AND RIGHT REAR TIRES. FOUND EXCESSIVE BEAD SEALER ON RIGHT REAR TIRE. ROAD TESTED AND UNABLE TO DUPLICATE COMPLAINT- VEHICLE IS FOLLOWING UNEVEN ROADS. PERFORMED SET UP AND MEASURE OF ALIGNMENT. ALIGNMENT WITHIN SPECIFICATION. SERVICE MANAGER AND MASTER TECHNICIAN ROAD TESTED VEHICLE WITH CLIENT. NO ABNORMALITIES IN OPERATION OF VEHICLE WITNESSED- TO SPEC. CLIENT STATED THAT SHE WOULD LIKE TO PURSUE LEMON LAW ON VEHICLE. ALTHOUGH DEALER CAN NOT VERIFY CUSTOMER'S COMPLAINT-CUSTOMER WAS ADVISED TO CONTACT CORPORATE. INSPECTION COMPLETE. ALIGNMENT SPECS GIVEN TO CLIENT. PHOTOS OF DAMAGE ON FILE.

C COURTESY MULTI POINT INSPECTION.
MULTI COURTESY MULTI POINT INSPECTION.

999 IC
PARTS: 0.00 LABOR: 0.00 OTHER: 0.00 TOTAL LINE C: 0.00

Customer to have 18.20 also before pulling out 3908 miles

check your fluid levels regularly?

important to do between Services. please feel free to call by and have your car checked and topped off.

On Behalf of the servicing dealer, I hereby certify that the information contained hereon is accurate unless otherwise shown. Flat Rate Hours are predicted on a time study guide and may not reflect the actual hours worked. There is the possibility that there will be a charge for shop supplies added to the repair order in the amount equal to 10% of the total labor cost. Applicable shop supply items include but are not limited to; nuts, bolts, washers, oils, rags, solvents, cleaners, etc. Some repairs may require use of materials that produce hazardous waste by products. A \$2.00 environmental compliance cost per repair will be assessed to safely dispose of these hazardous wastes. We guarantee our service work for 90 days or 4,000 miles whichever comes first. If our repair or replacement fails in normal service within that period, we'll fix it free of charge during normal business hours- parts and labor unless specified otherwise. All repairs and parts listed were furnished in compliance with the Michigan Motor Vehicle Service and Repair Act (P.A. 300)

LABOR AMOUNT	0.00
PARTS AMOUNT	0.00
GAS, OIL, LUBE	0.00
SUBLET AMOUNT	0.00
MISC. CHARGES	0.00
TOTAL CHARGES	0.00
LESS INSURANCE	0.00
SALES TAX	0.00
PLEASE PAY THIS AMOUNT	0.00

Authorized Dealership Employee

Genthe Honda Thanks You for Your Business!

Customer Signature