

INFORMATION Redacted PURSUANT TO THE FREEDOM OF
INFORMATION ACT (FOIA), 5 U.S.C . 552(B)(6)

From: [Wells, Cynthia CTR \(NHTSA\)](#)
To: [Fogle, Brenda CTR \(NHTSA\)](#)
Subject: FW: FW: NHTSA: Follow up to ODI Complaint: 10509699
Date: Tuesday, June 18, 2013 10:37:39 AM
Attachments: [recall_campaign_bulletin NTB04-062c.pdf](#)
[recall_service.pdf](#)
[receipt.pdf](#)
[service_invoice.pdf](#)
[updated_Questionnaire_10509699.pdf](#)

EQ-10509699-6396

From: Williams, Maritza CTR (NHTSA) **On Behalf Of** DataQuality, DataQuality (NHTSA)
Sent: Monday, June 17, 2013 2:02 PM
To: Wells, Cynthia CTR (NHTSA)
Subject: FW: FW: NHTSA: Follow up to ODI Complaint: 10509699

From: [REDACTED]
Sent: Thursday, June 13, 2013 11:07 AM
To: DataQuality, DataQuality (NHTSA)
Subject: Re: FW: NHTSA: Follow up to ODI Complaint: 10509699

On Wed, Jun 5, 2013 at 5:53 AM, <EVOQ@dot.gov> wrote:

Please see the attached copy of your recent complaint and instructions. Please make any necessary edits and return via email to dataquality@dot.gov or fax to (202) 366-1767. Due to the volume of complaints we receive and our limited resources, we cannot respond to every complaint. NHTSA/Office of Defects Investigation



RECALL CAMPAIGN BULLETIN

Reference:

NTB04-062c

Date:

January 23, 2009

VOLUNTARY RECALL CAMPAIGN FUEL SENDING UNIT

This bulletin has been amended. The part order email address in the Parts Information has been changed. No other changes have been made. Please discard all previous versions of this bulletin.

CAMPAIGN I.D. # / NHTSA #: R0401 & R0402 / 04V-230

APPLIED VEHICLES: 1999 - 2003 Frontier (D22)
2000 – 2003 Xterra (WD22)

APPLIED VINS: Vehicles built within the below VIN ranges:

Frontier:

- 1N6*D2*Y*XC300001-345558
- 1N6*D2*T*YC300001-437820
- 1N6*D2*Y*YC300002-437828
- 1N6*D2*T*1C300001-404427
- 1N6*D2*Y*1C300002-404387
- 1N6*D2*T*2C300002-396643
- 1N6*D2*X*2C300011-396637
- 1N6*D2*Y*2C300001-396641
- 1N6*D2*T*3C400001-438379
- 1N6*D2*X*3C400006-438371
- 1N6*D2*Y*3C400002-438380

Xterra:

- 5N1*D2*T*YC500001-612775
- 5N1*D2*Y*YC500005-612751
- 5N1*D2*T*1C500001-599018
- 5N1*D2*Y*1C500002-599014
- 5N1*D2*T*2C500000-606345
- 5N1*D2*Y*2C500002-606344
- 5N1*D2*T*3C600001-666247
- 5N1*D2*Y*3C600000-666244

NOTE: Use Service Comm to confirm campaign eligibility.

INTRODUCTION

Nissan has determined that some 1999-2003 model year Nissan Frontier vehicles, equipped with the 6 cylinder engine and 2000-2003 model year Nissan Xterra vehicles, equipped with the 4 and 6 cylinder engine may have a defect which relates to motor vehicle safety. There is a possibility that the fuel pump terminal on the fuel-sending unit may develop a crack in its plastic molding which could cause the terminal strip to corrode under some environmental conditions. If corrosion occurs, the terminal strip could eventually break. This will cause the fuel pump to stop operating and will result in not being able to start the engine or cause the engine to stop running without warning during vehicle operation, which could result in a crash. To prevent this condition from occurring, Nissan is conducting a Voluntary Safety Recall Campaign to replace or repair the fuel-sending unit.

IDENTIFICATION NUMBER

Nissan has assigned identification number R0401 & R0402 to this campaign. These numbers must appear on all communications and documentation of any nature dealing with this campaign.

R0401

- This PNC group is for vehicles located in the “Salt” states (shown below). Service Comm will identify these vehicles.

Salt States Include:

Connecticut	Kentucky	New Hampshire	Tennessee
Delaware	Maine	New Jersey	Vermont
District of Columbia	Maryland	New York	Virginia
Illinois	Massachusetts	Ohio	West Virginia
Indiana	Michigan	Pennsylvania	Wisconsin
Iowa	Minnesota	Rhode Island	

R0402

- This PNC group is for vehicles identified as NOT being located in the “Salt” states. Service Comm will identify these vehicles.

NUMBER OF VEHICLES POTENTIALLY AFFECTED

The number of vehicles potentially affected is approximately 590,000.

DEALER RESPONSIBILITY

It is the retailer’s responsibility to check Service Comm for the campaign status on each vehicle falling within the range of this voluntary safety recall which for any reason enters the service department. This includes vehicles purchased from private parties or presented by transient (tourist) owners and vehicles in a dealer’s inventory. **Federal law requires that new vehicles in dealer inventory which are the subject of a safety recall must be corrected prior to sale. Failure to do so can result in civil penalties by the National Highway Traffic Safety Administration.** While federal law applies only to new vehicles, Nissan strongly encourages dealers to correct any used vehicles in their inventory before they are retailed.

The following items are required to perform the procedures contained in this bulletin.

- **Cleaning/Sealing Kit #B5060-79900**
 - One kit per vehicle
 - Kit contains: 1 Cleaning Adapter, 1 Sealing Adapter, and 1 Connector Cover
- **Kit A (3-Port):** Kit contains: 4 Rubber Plugs and 1 Protective Cover (kit can be re-used)
- **Kit B (5-Port):** Kit contains: 6 Rubber Plugs and 1 Protective Cover (kit can be re-used)
- **Connector Removal Tool #J-47009** (previously sent to dealer)
- **Nylon Brush #J-47239** (previously sent to dealer)
- **Vacuum Pump #J-42909** (essential tool)
- **Hose Removal Pliers** (recommended tool: Lisle Corp. #47900, or equivalent)
- **Copper/Bronze Bristle Brush** (recommended tool)
- **Abrasive Pad** (recommended item: 3M Scotch Brite Pad #051131-07447, or equivalent)
- **Protective Coating #KY140-9Z400** (one can good for about 40 vehicles)
- **Brake Cleaner #999MP-AH001P** (one can good for about 20 vehicles)
- **Rust Penetrant #999MP-A3020P** (one can good for about 20 vehicles)
- **Tectyl 517 (Bitumen) Wax Sealer #999MP-9G001P** (one can good for about 20 vehicles)

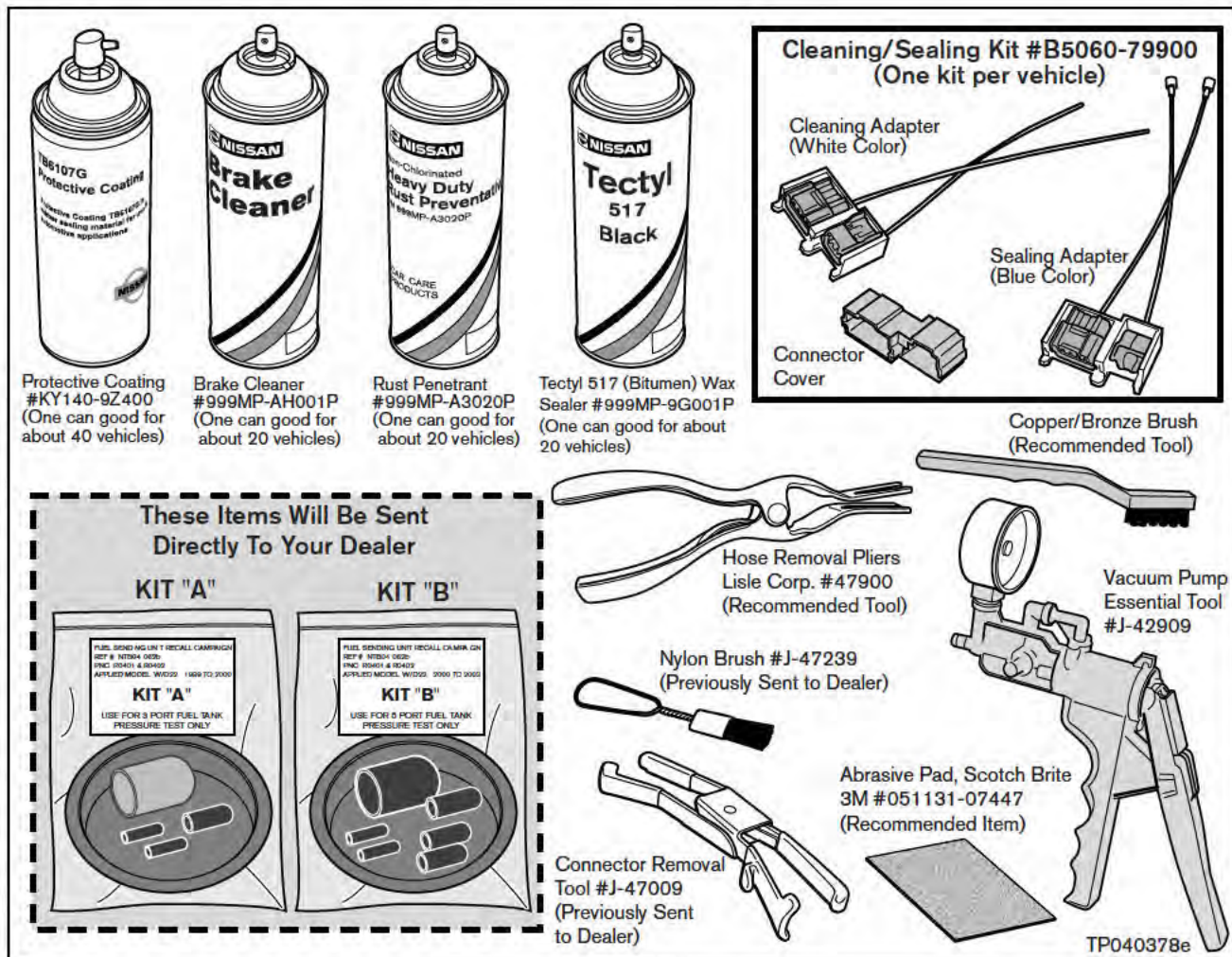

Figure 1

Frontier: Inspect Fuel Sending Unit

1. Raise the vehicle on a hoist so you can reach the Fuel Sending Unit Connectors (see Figure 2).

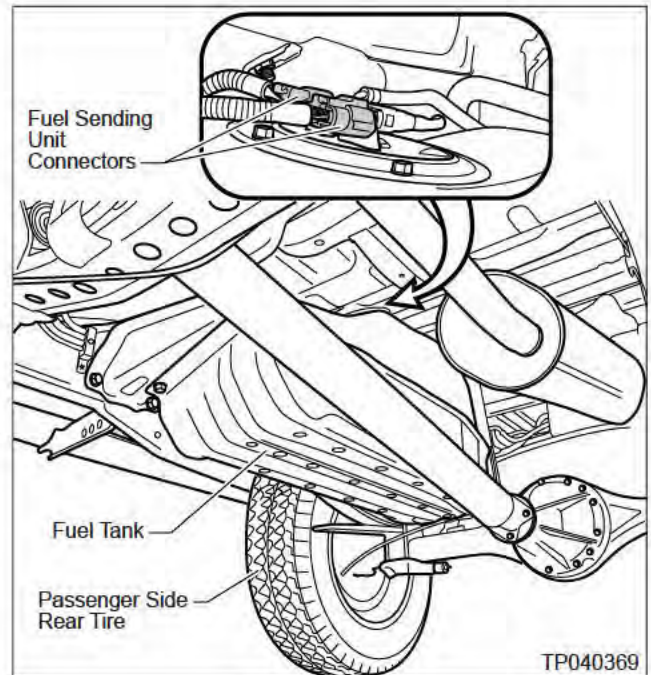

Figure 2

2. Use the Connector Removal Tool #J-47009 to disconnect the Fuel Sending Unit Connectors (4-wire connector and 2-wire connector). See Figure 3.

NOTE: For 1999 and 2000 MY Frontier:

- The Connector Removal Tool cannot be used on the 4-wire connector.
- To release this connector, push forward on the Sliding Button (on top of the connector). See Figure 3.

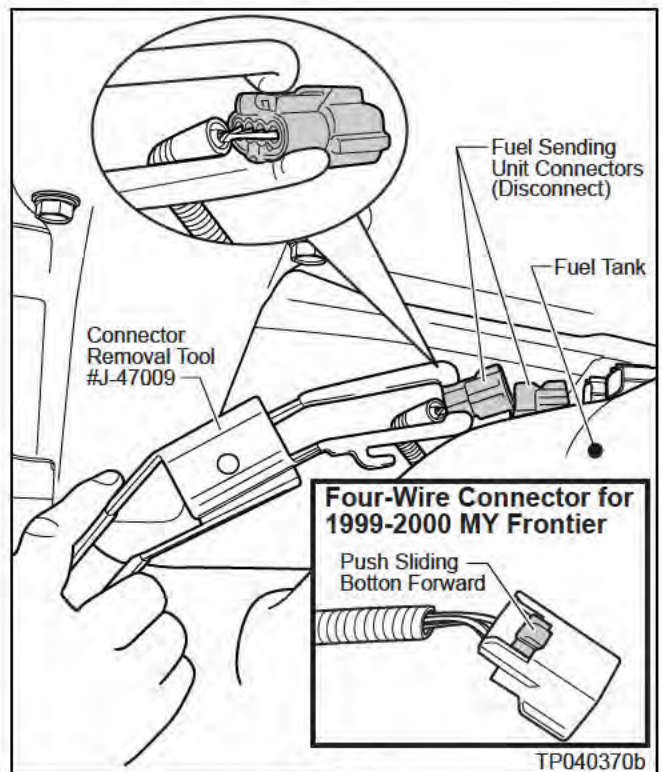

Figure 3

3. Install the Connector Cover onto the Fuel Sending Unit Connectors until it is fully seated. See Figure 4.

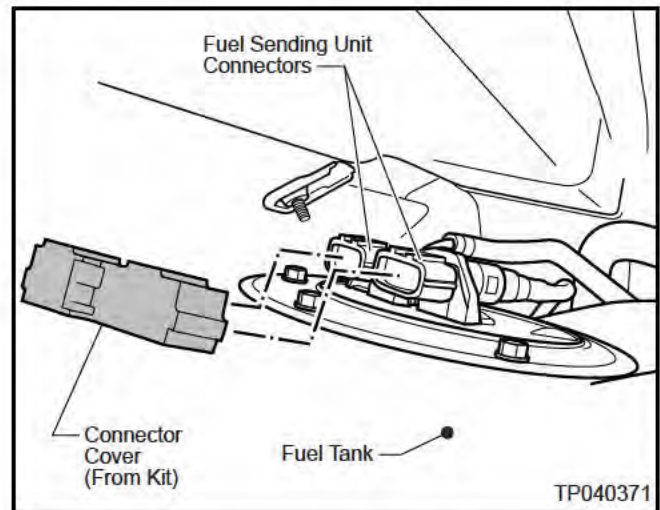

Figure 4

4. Use the Nylon Brush #J-47239 to loosen/remove dirt and debris on the vertical surface of the Fuel Sending Unit Connectors (see Figure 5).
5. Remove the Connector Cover once you're done with the above step.

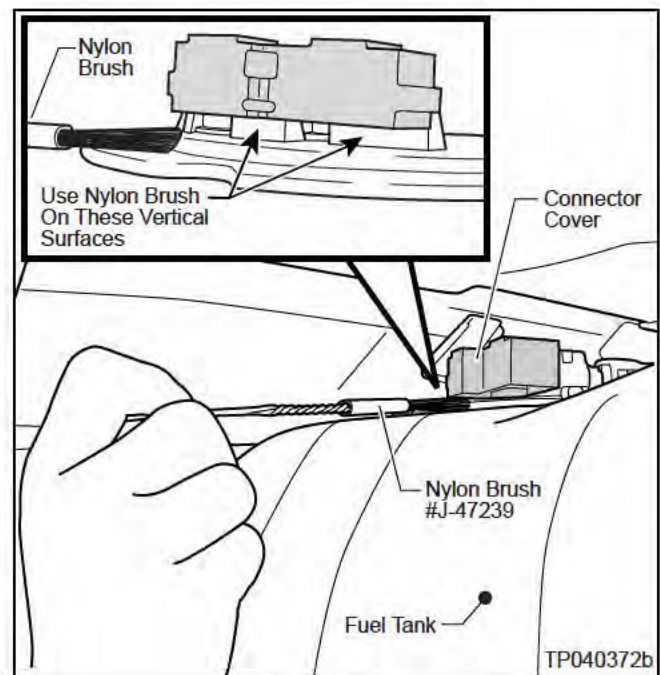

Figure 5

6. Install the Cleaning Adapter (white color adapter) onto the Fuel Sending Unit Connectors until it clicks (locks) in place. See Figure 6.

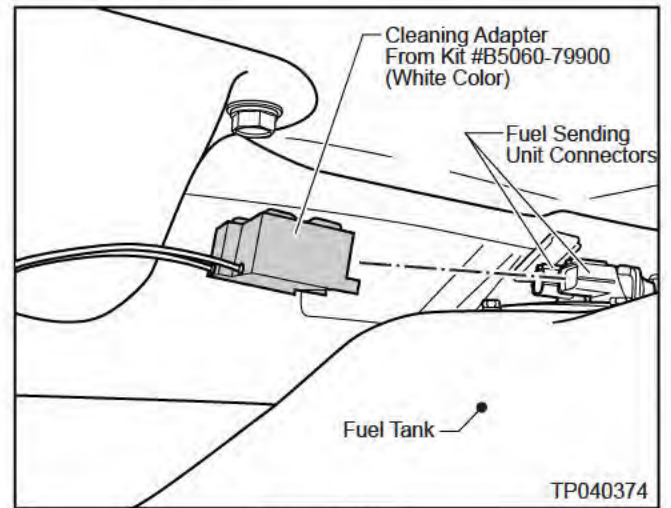

Figure 6

CAUTION: When performing the following steps, use suitable protective gloves, safety glasses, or face shield.

7. Spray Brake Cleaner #999MP-AH001P through each Adapter Tube for about two seconds (see Figure 7).
 - You will need to insert the Adapter Tube into the Brake Cleaner spray can nozzle.
8. Remove and discard the Cleaning Adapter.

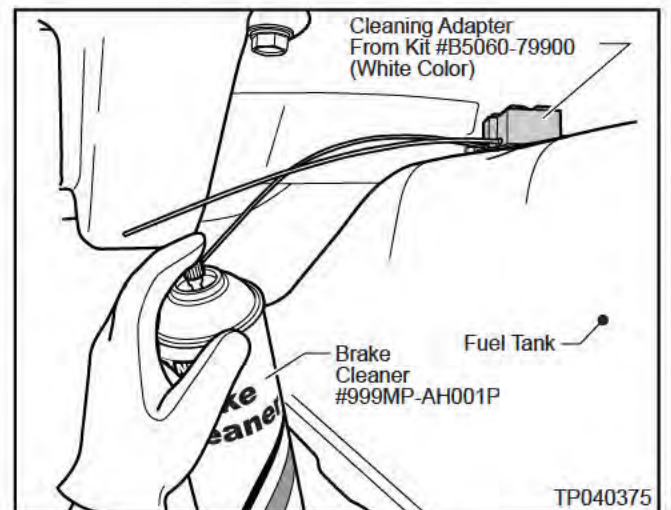

Figure 7

NOTE:

- When you remove the Cleaning Adapter, one or both of the connector inserts may come out of the Adapter.
- Make sure you remove the insert(s) from the Fuel Sending Unit connector(s).

9. Install the Connector Cover onto the Fuel Sending Unit Connectors until it is fully seated. See Figure 8.

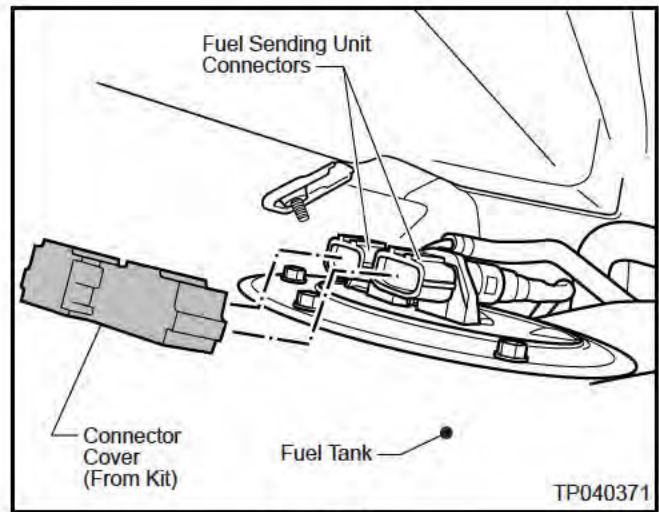

Figure 8

10. Use shop air to thoroughly dry the vertical surface of the Fuel Sending Unit Connectors, then remove the Connector Cover. See Figure 9.

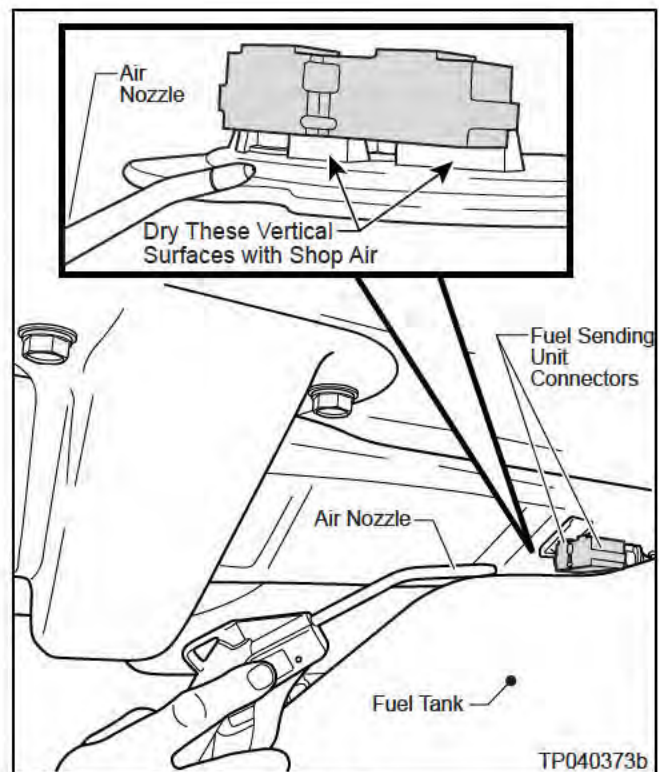
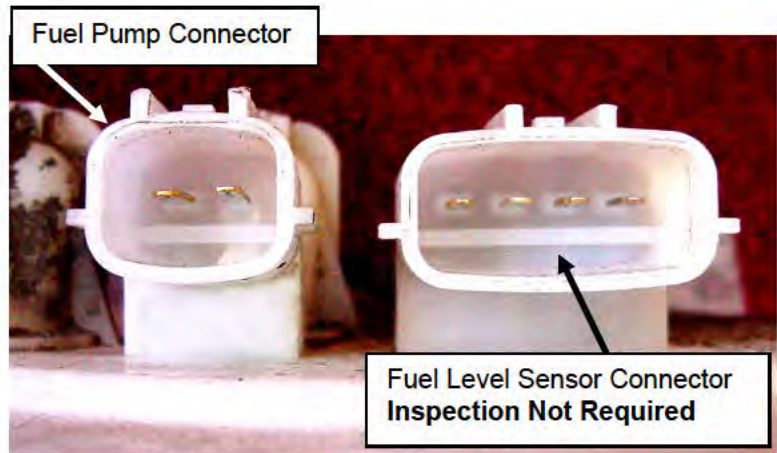

Figure 9

11. Inspect the **Fuel Pump** Connector for green corrosion.

- Inspection is NOT required for the Fuel Level Sensor Connector.
 - Use a mirror (if needed) to look at the connector.
 - See illustrations below for examples of green corrosion.
- a. If **OK**, go to “Frontier: Add Protective Coating To Fuel Sending Unit” (next page).
 - b. If **NG**, go to “Frontier: Replace Fuel Sending Unit” (page 11).

OK
(No Green Corrosion)



NG
(With Green Corrosion)

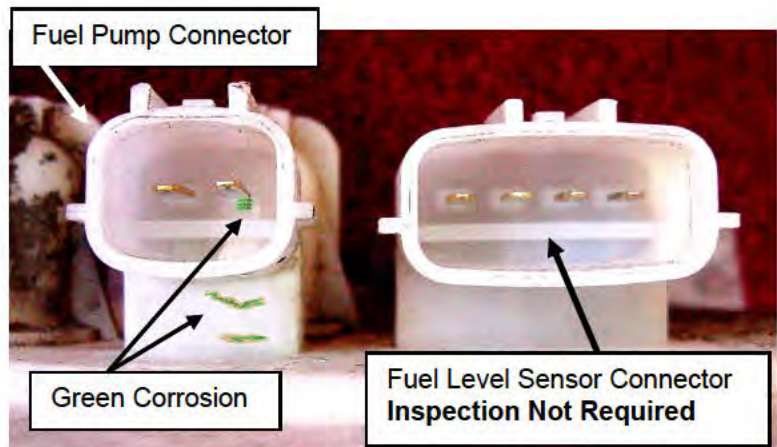

NG
(With Green Corrosion)

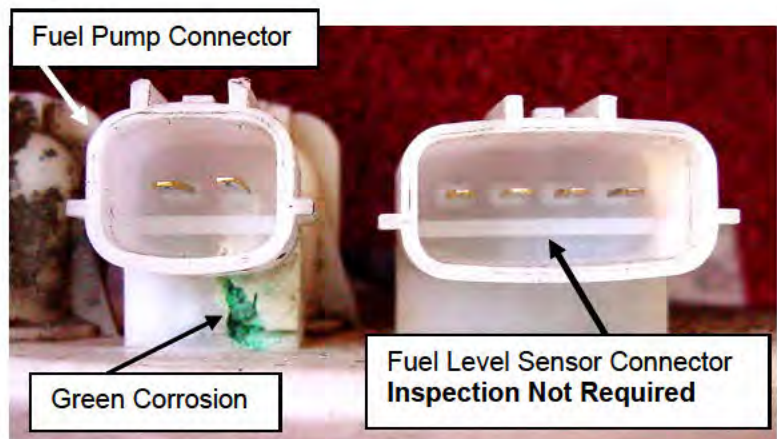

Frontier: Add Protective Coating To Fuel Sending Unit

1. Install the Sealing Adapter (blue color adapter) onto the Fuel Sending Unit Connectors until it clicks (locks) in place. See Figure 10.

CAUTION: When performing the following steps, use suitable protective gloves, safety glasses, or face shield.

2. Shake the Protective Coating can #KY140-9Z400 to thoroughly mix the contents.
3. Spray the Protective Coating #KY140-9Z400 through each Adapter Tube for about two seconds (see Figure 11).
 - You will need to attach the Adapter Tube onto the Protective Coating spray can nozzle.
 - You do not have to wait for the Protective Coating to dry. Proceed to the next step.

4. Remove and discard the Sealing Adapter.

NOTE:

- When you remove the Sealing Adapter, one or both of the connector inserts may come out of the Adapter.
 - Make sure you remove the insert(s) from the Fuel Sending Unit connector(s).
5. Re-connect the Fuel Sending Unit Harness Connectors, making sure they are securely locked into position.
 6. Start the vehicle and confirm proper engine running and fuel gauge operation.

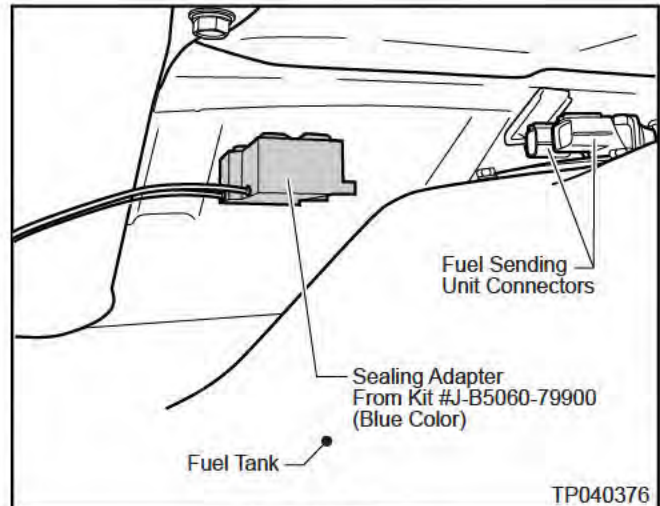

Figure 10

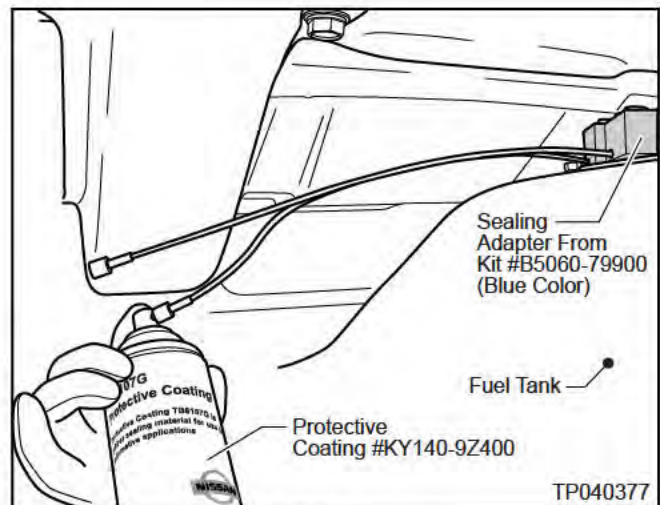

Figure 11

Frontier: Replace Fuel Sending Unit

WARNING:

- Before performing any of the Service Procedures below, be certain there are no ignition sources (i.e., open flames, sparks, etc.) in or around the vehicle/work area.
- Make sure the appropriate rated fire extinguisher is available for immediate use.
- Use suitable protective gloves, safety glasses, or face shield.

CAUTION: Use suitable covers to protect carpet, upholstery, etc.

NOTE: The Fuel Sending Unit that you remove from the vehicle may look different from the new replacement service part (see Figure 43 on page 32).

1. Release the fuel pressure from the fuel system using CONSULT-II (or other suitable method). **Follow the procedure in the “EC” section of the Service Manual.**
2. Use a suitable device to remove the fuel from the fuel tank.
3. Remove the fuel tank:
 - For detailed instructions on fuel tank removal and installation, refer to the vehicle-specific Service Manual, **Section FE (Fuel And Exhaust)/Fuel System/Removal and Installation/Fuel Tank.**

WARNING: Follow all warnings and cautions provided in the Service Manual.

- Before disassembly: use duct tape and an “indelible” marker (permanent marker), to mark the matching pipes and hoses, which are attached to the fuel filler neck (see Figure 12).

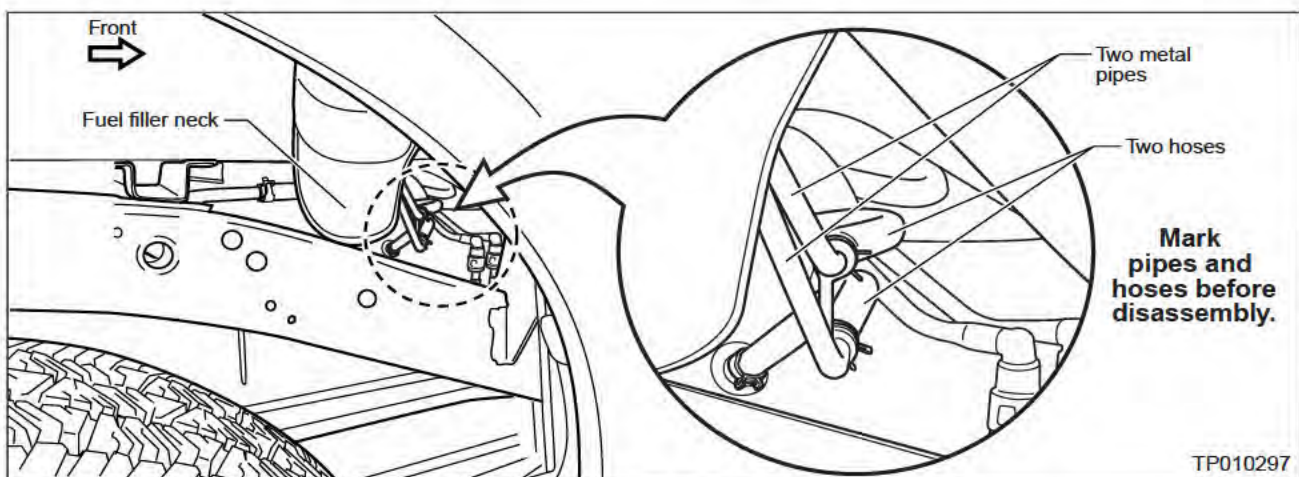

Figure 12

- The hoses **MUST** be re-connected to the same pipes they were removed from.
- If the hoses are re-connected incorrectly, refueling difficulties may occur.

4. Plug all Fuel Tank openings, except the Pressure Port (see Figure 13).
 - Use **Kit A** for Fuel Tanks with 3 ports (1999-2000 Frontier & Xterra)
 - Use **Kit B** for Fuel Tanks with 5 ports (2000-2003 Frontier & Xterra)

NOTE: Kit A and Kit B will be automatically sent to each dealer.

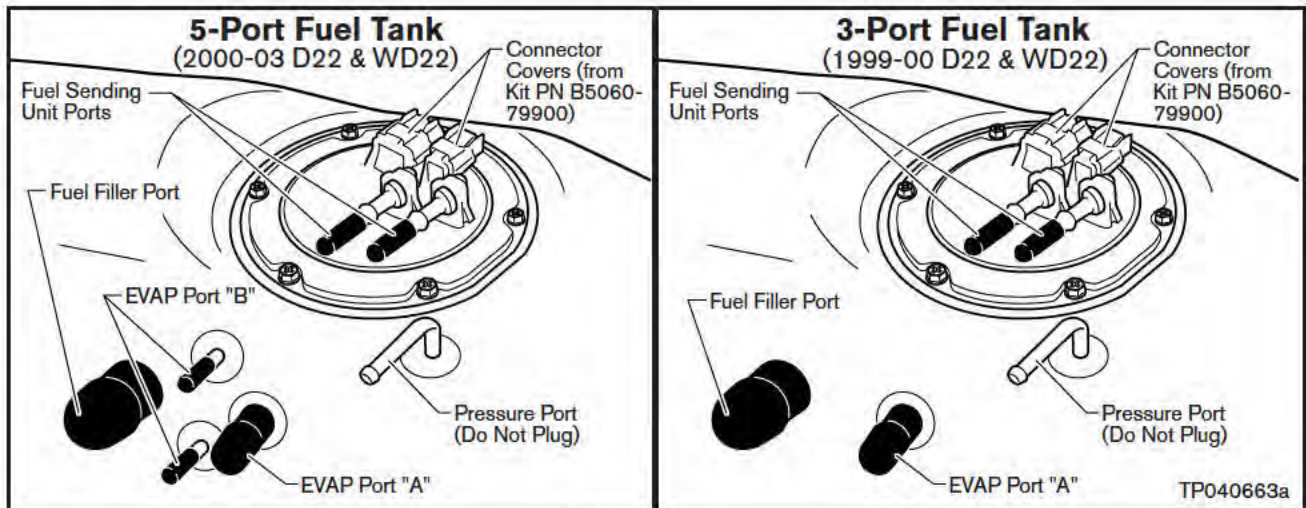

Figure 13

5. Install the Connector Covers (from Kit #B5060-79900) onto the Fuel Sending Unit Connectors until they are fully seated (see Figure 13).
6. Remove the Fuel Sending Unit as follows:
 - a. First, use shop air to clean the area around the Fuel Sending Unit and Mounting Flange (see Figure 14).

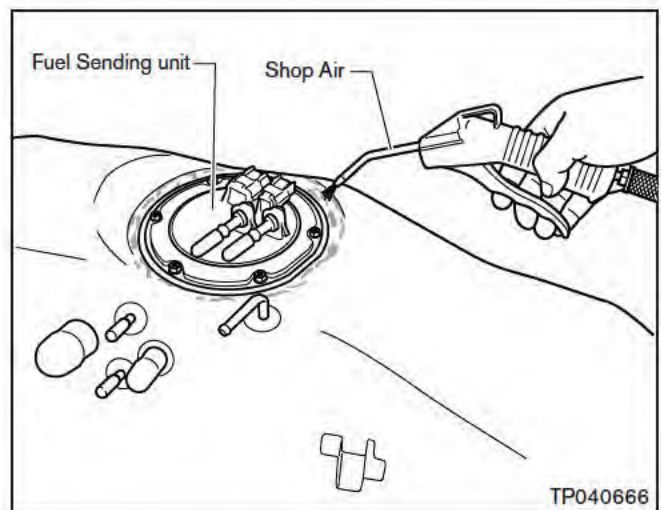

Figure 14

b. Then, apply Rust Penetrant (999MP-A3020P) to the Fuel Sending Unit Mounting Flange Bolts (see Figure 15). Allow the penetrant to “soak” for a few minutes.

c. **Using hand tools ONLY**, gently remove the Fuel Sending Unit Mounting Flange Bolts.

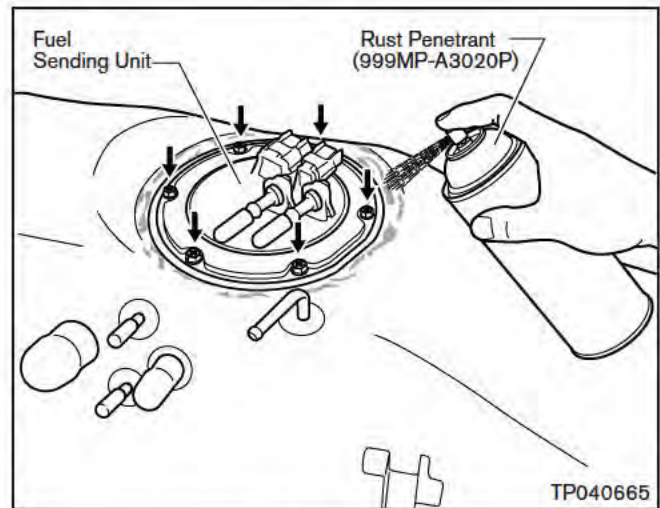

Figure 15

d. Remove the Fuel Sending Unit.

NOTE: To disconnect the fuel return hose from the Fuel Sending Unit, do the following:

- Push **UP** on the fuel return hose connector 1 to 2 mm (around 1/16-inch). See Figure 16A.
- With the hose connector pushed **UP**, hold the two plastic tabs. See Figure 16B.
- While holding the plastic tabs, pry **DOWN** on the hose connector with hose removal pliers (such as #47900, Lisle Corporation or equivalent). See Figure 16C.

NOTE: The hose removal pliers (noted above) are available from TECH-MATE at 1-800-662-2001 (option #4).

- Cut and discard the old Fuel Sending Unit O-ring. You'll be installing a new O-ring later.

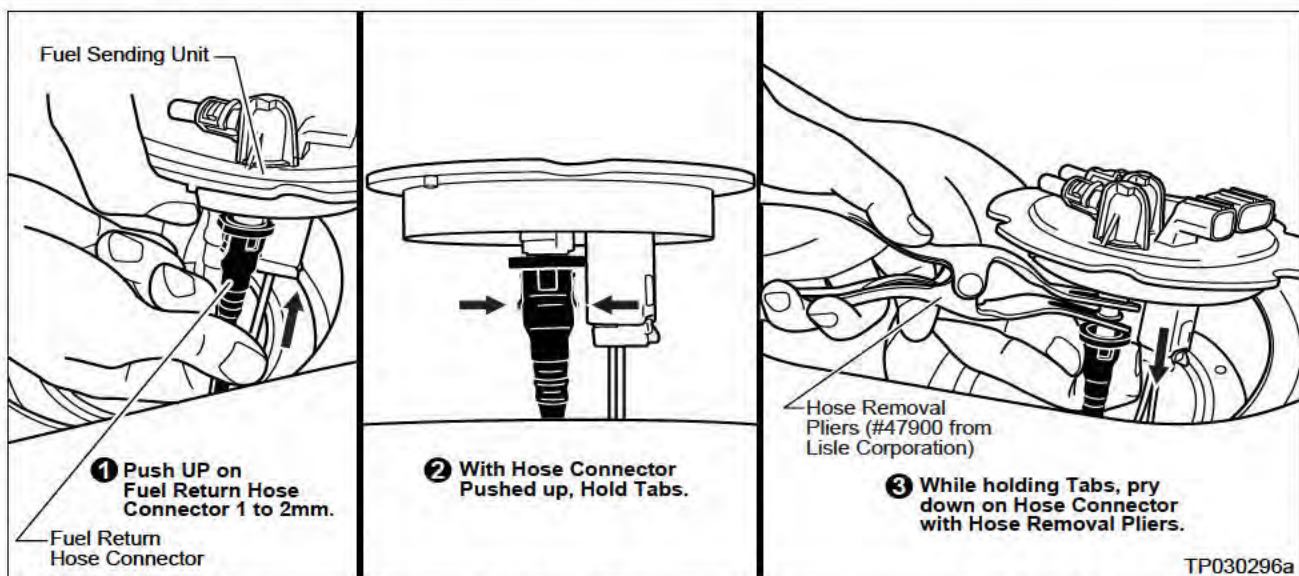

Figure 16A

Figure 16B

Figure 16C

7. Inspect the Fuel Tank Sending Unit Mounting Flange and O-Ring Groove (see Figure 17 and 18).

OK

IF:

- There are no broken bolts on the Mounting Flange.
- The O-Ring groove has **NO** or light rust (no scaling) and can be cleaned with a light abrasive pad (such as Scotch Brite Pad 3M #051131-07447) or a copper/bronze bristle brush. See Figures 19 & 20.

THEN:

- The Fuel Tank is OK and can be re-used.
- Proceed with step 8.

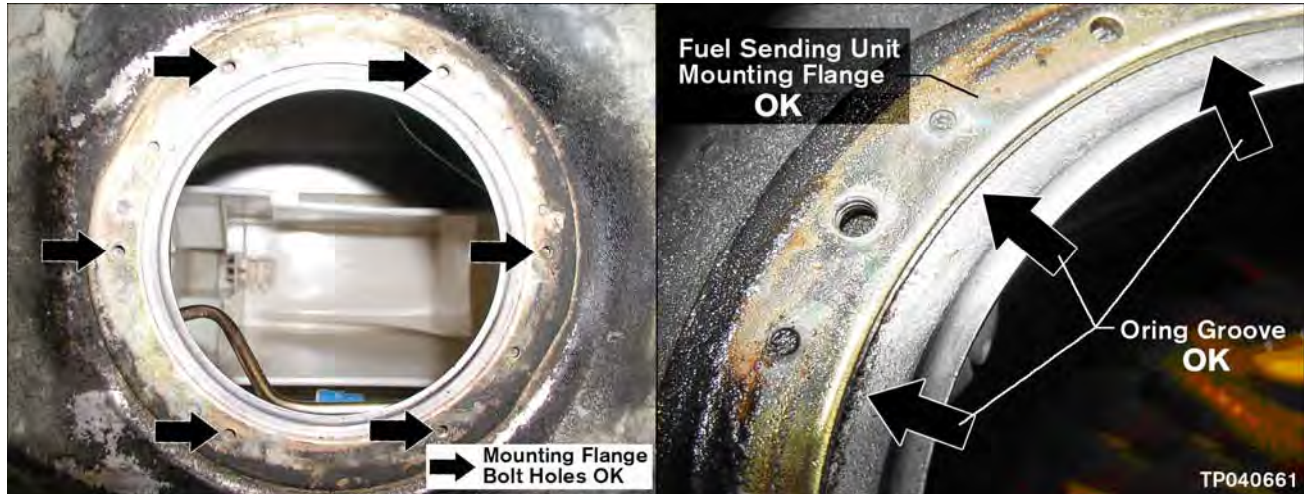

Figure 17

NG

IF:

- There are broken bolts on the Mounting Flange, or
- The O-Ring groove is rusty (scaling) and can **NOT** be cleaned with a light abrasive pad (such as Scotch Brite Pad 3M #051131-07447) or a copper/bronze bristle brush.

THEN:

- The Fuel Tank is NO GOOD and must be replaced.
- Replace the Fuel Tank, perform steps 11 & 12, then proceed with Step 17.

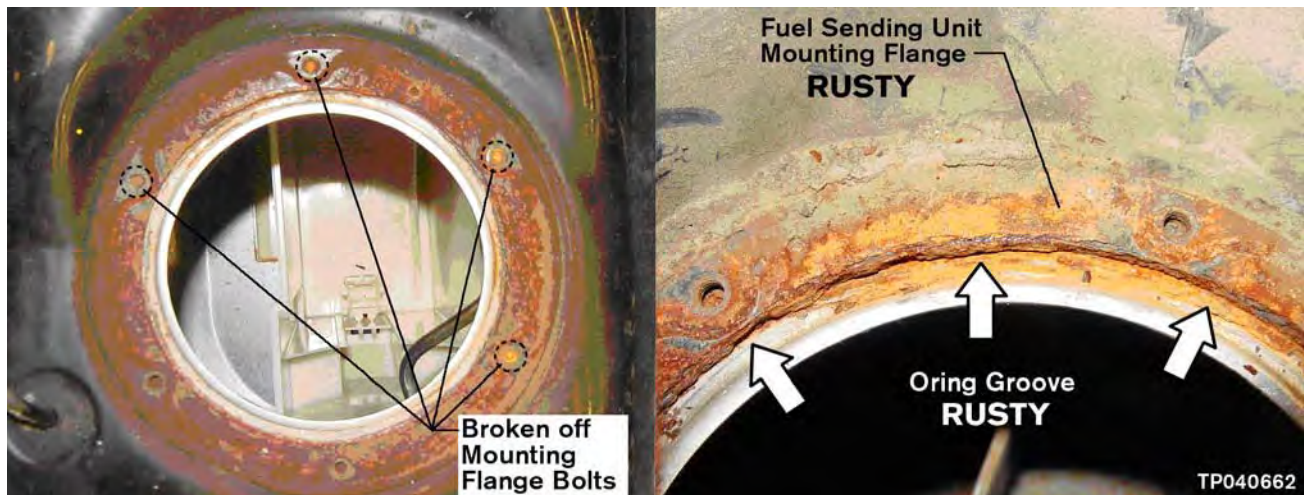

Figure 18

NOTE: If a new Fuel Tank is installed, perform steps 11 & 12 below, then proceed with step 17 on page 17.

8. Insert the Protective Cover provided in Kit A (3-port) or Kit B (5-port) in the Fuel Tank opening (see Figure 19).

CAUTION: Make sure the Protective Cover is properly inserted/seated to prevent rust and debris from entering the Fuel Tank.

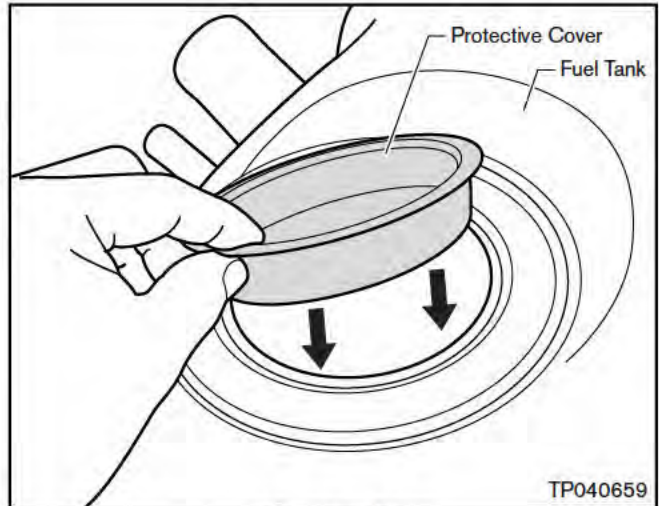

Figure 19

9. Completely clean the Fuel Tank Sending Unit Mounting Flange and O-Ring Groove by hand using Scotch Brite Pad 3M #051131-07447 or a copper/bronze bristle brush. See Figure 20.

WARNING:

- Do NOT use any power tools (pneumatic or electric) for cleaning the Fuel Tank Sending Unit Mounting Flange and O-Ring Groove.
- Use proper care and precaution when working around gasoline.
- Be certain there are no ignition sources (i.e., open flames, sparks, etc.) in or around the vehicle/work area.
- Make sure the appropriate rated fire extinguisher is available for immediate use.
- Use suitable protective gloves, safety glasses, or face shield.

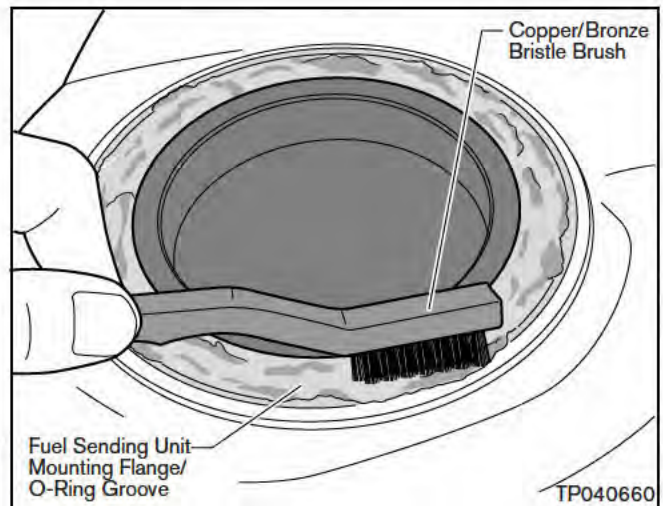

Figure 20

10. Use shop air to completely blow off/clean the Fuel Tank Sending Unit Mounting Flange and O-Ring Groove.
11. Install the new Fuel Sending Unit O-ring in the groove on the fuel tank.
12. Use the new mounting screws to install the Fuel Sending Unit on the fuel tank. Refer to the "FE" section in the applicable Service Manual.
 - Tighten the Fuel Sending Unit mounting screws to **2.0 – 2.5 N-m (0.20 – 0.26 kg-m, 17.4 – 22.6 in-lb)**.

REMEMBER: If a new Fuel Tank is installed, perform steps 11 & 12 on the previous page, then proceed with step 17 on page 17.

13. Now check for leaks. Put some soapy water around the outer edge of the Fuel Sending Unit Mounting Flange.

14. Connect Essential Tool Vacuum Pump J-42909 to the Fuel Tank Pressure Port (see Figure 21).

- Before using the Vacuum Pump, make sure it works properly and can hold pressure.

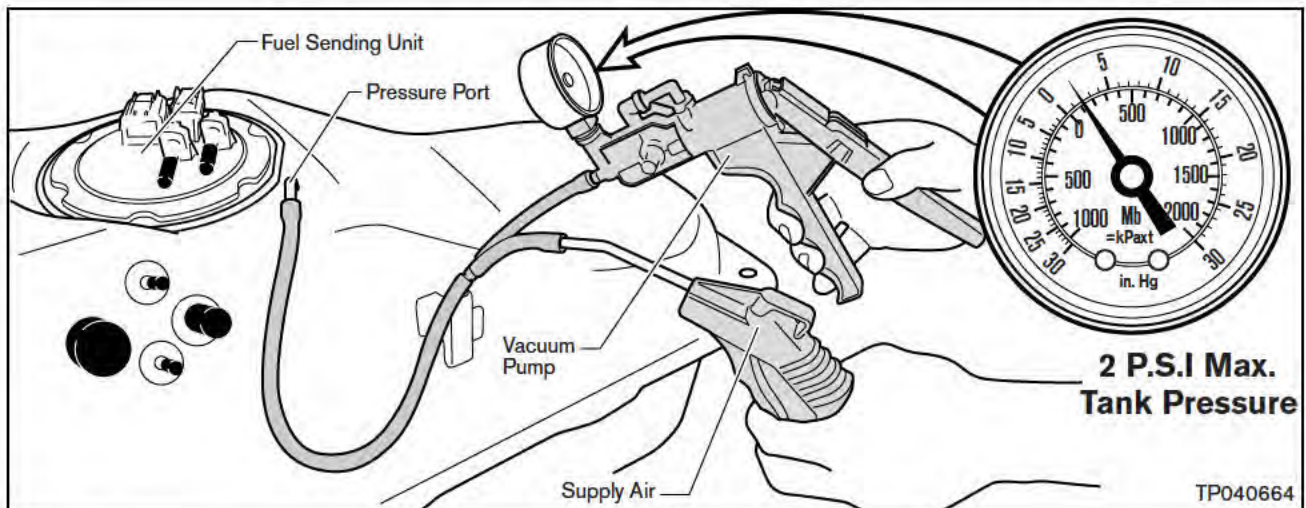

Figure 21

15. Apply air pressure, not to exceed **2 p.s.i. (Maximum)** regulated air pressure, to the Fuel Tank using the Vacuum Pump/supply air.

NOTE: After you pressurize the Fuel Tank, “pinch off” the hose going to the supply air to prevent pressure leakage.

16. Monitor the air pressure in the Fuel Tank for 1 minute:

- a. If the air pressure holds at 2 p.s.i. (for 1 minute), and there are no bubbles around the Fuel Sending Unit, proceed with the next step.
- b. If the air pressure does NOT hold at 2 p.s.i. (for 1 minute), and/or there are bubbles around the Fuel Sending Unit, replace the Fuel Tank * and proceed with the next step.

* Make sure you transfer the new O-Ring and Fuel Sending Unit from the old Fuel Tank to the new Fuel Tank.

17. Apply Tectyl 517 (Bitumen) Wax Sealer to the Fuel Sending Unit Mounting Flange area as follows:

a. Completely clean and dry off (with shop air) the Mounting Flange area.

b. Then, apply ONLY Tectyl 517 (Bitumen) Wax Sealer (999MP-9G001P) around the outer edge of the Fuel Sending Unit Mounting Flange (see Figure 22).

- Thoroughly shake the can of Wax Sealer to ensure complete mixing.

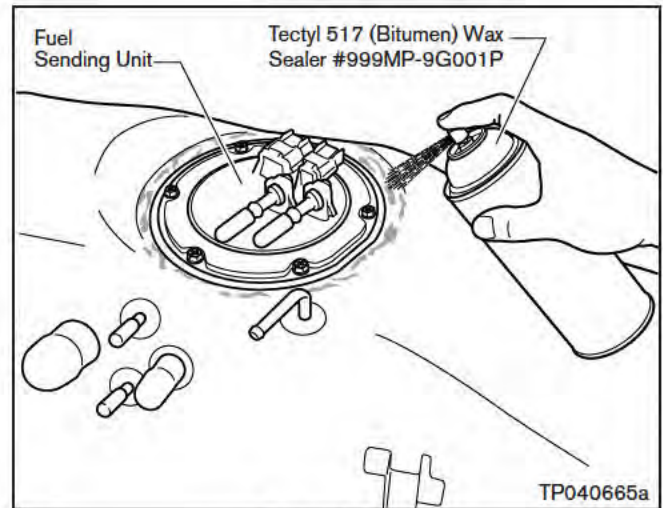

Figure 22

18. Remove all Rubber Caps and the Connector Covers from the Fuel Tank/Sending Unit.

19. Re-install the fuel tank. Refer to the "FE" section in the applicable Service Manual.

IMPORTANT:

- Make sure the hoses removed from the fuel tank are correctly installed to the same pipes they were removed from.
- Make sure the Fuel Sending Unit Wire Harness Connectors are securely locked into position.
- Make sure all Fuel/EVAP hoses are in good condition (no cracks, splits, etc.) and are securely reconnected to prevent leaks.

20. Re-assemble all previously removed components in the reverse order you removed them.

21. Start the vehicle and confirm proper engine running and fuel gauge operation.

Xterra: Inspect Fuel Sending Unit

CAUTION: Use suitable covers to protect carpet, upholstery, paint, etc. when performing this procedure.

1. Remove the rear, passenger-side, bottom Seat Cushion as follows:
 - a. Pull on the Seat Cushion Release Straps while lifting UP on the front edge of the Seat Cushion (see Figure 23).
 - b. Remove the Cushion and place it in a clean, safe location.

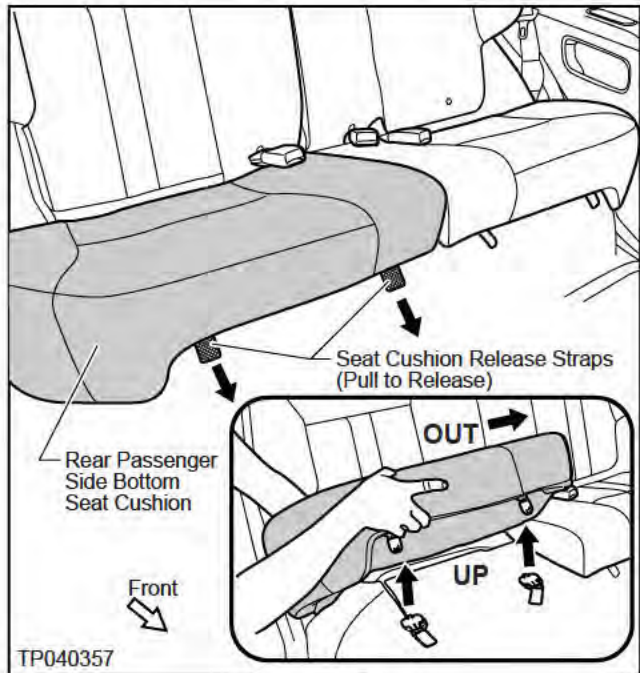

Figure 23

2. Remove four Bolts and remove the Body Cover Plate (see Figure 24).

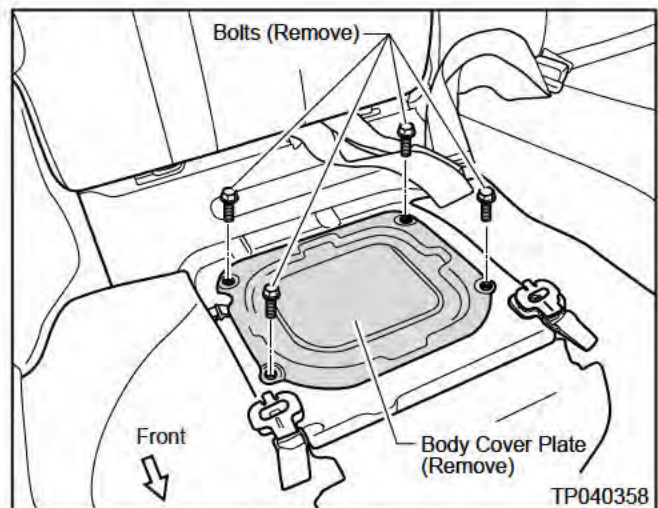

Figure 24

3. Remove three Bolts and lift the Fuel Sending Unit Inspection Cover UP (see Figure 25).

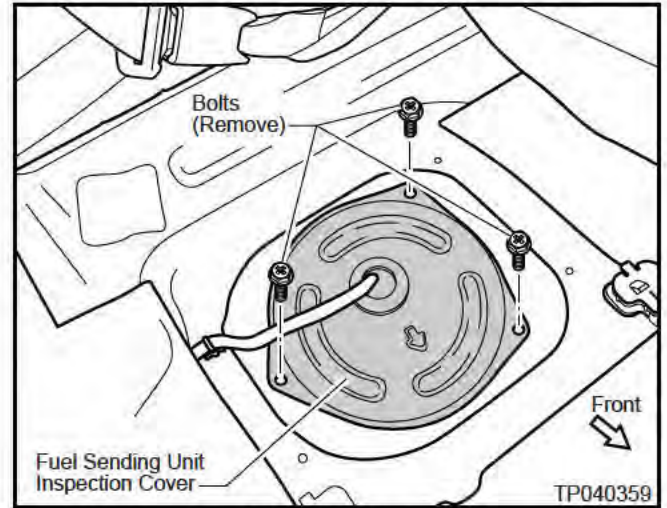

Figure 25

4. Disconnect the Fuel Sending Unit Connectors (see Figure 26).

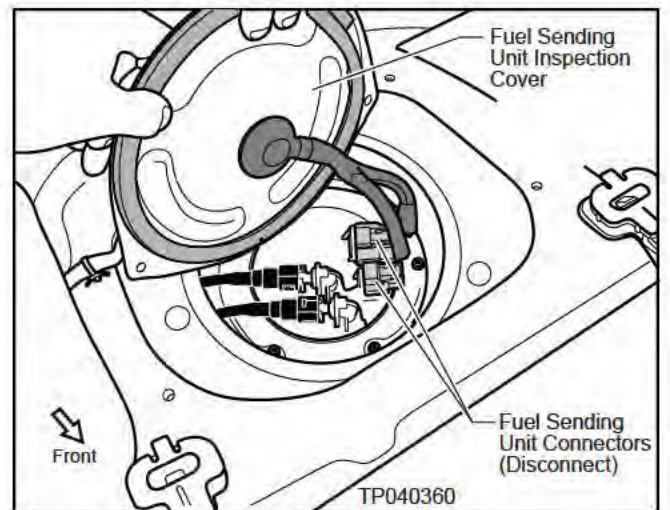

Figure 26

5. Install the Connector Cover onto the Fuel Sending Unit Connectors until it is fully seated. See Figure 27.

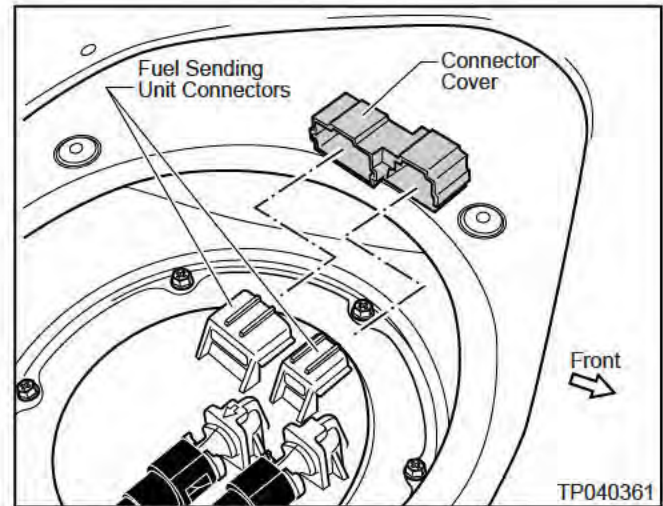

Figure 27

6. Use the Nylon Brush #J-47239 to loosen/remove dirt and debris on the vertical surface of the Fuel Sending Unit Connectors (see Figure 28).

NOTE: If needed, you can bend the Brush to better reach the vertical surfaces.

7. Remove the Connector Cover once you're done with the above step.

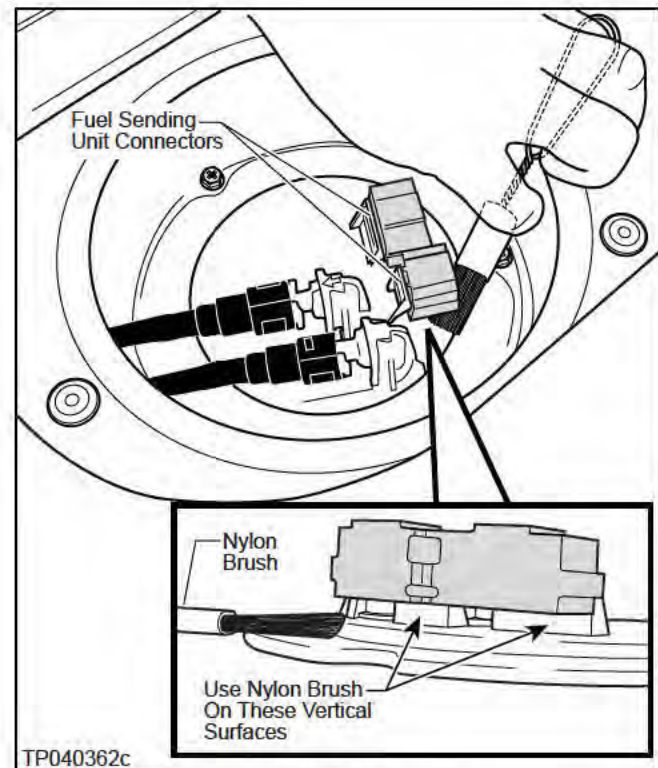

Figure 28

8. Install the Cleaning Adapter (white color adapter) onto the Fuel Sending Unit Connectors until it clicks (locks) in place. See Figure 29.

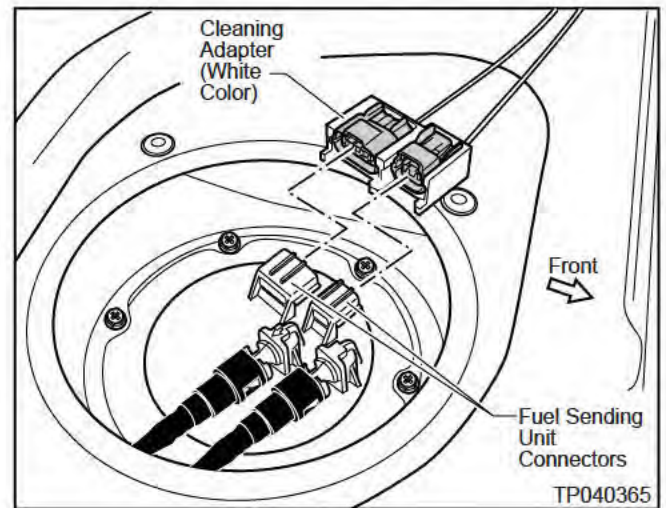

Figure 29

CAUTION: When performing the following steps:

- Use suitable protective gloves, safety glasses, or face shield.
 - Use suitable covers to protect carpet, upholstery, etc.
9. Spray Brake Cleaner #999MP-AH001P through each Adapter Tube for about two seconds (see Figure 30).
 - You will need to insert the Adapter Tube into the Brake Cleaner spray can nozzle.

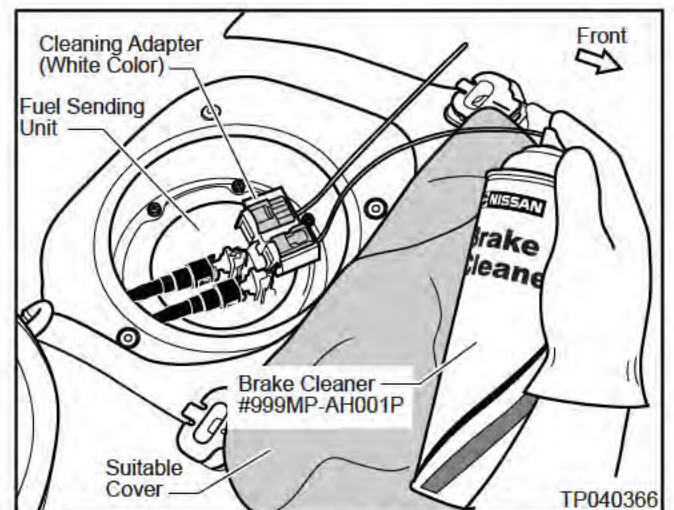

Figure 30

10. Remove and discard the Cleaning Adapter.

NOTE:

- When you remove the Cleaning Adapter, one or both of the connector inserts may come out of the Adapter.
- Make sure you remove the insert(s) from the Fuel Sending Unit connector(s).

11. Install the Connector Cover onto the Fuel Sending Unit Connectors until it is fully seated. See Figure 31.

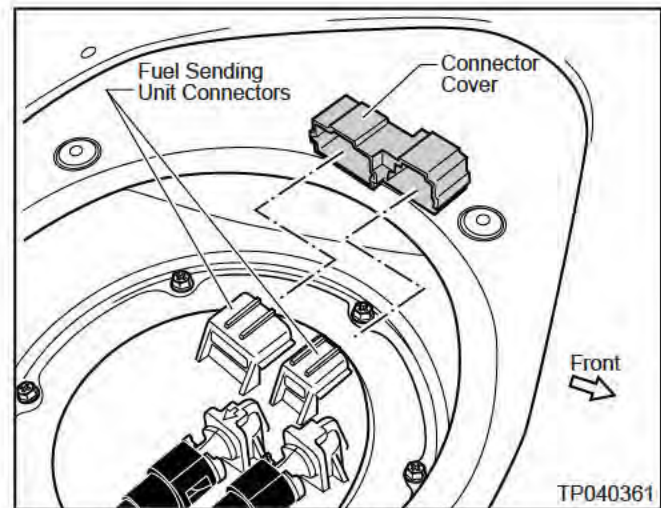

Figure 31

12. Use shop air to thoroughly dry the vertical surface of the Fuel Sending Unit connectors, then remove the Connector Cover. See Figure 32.

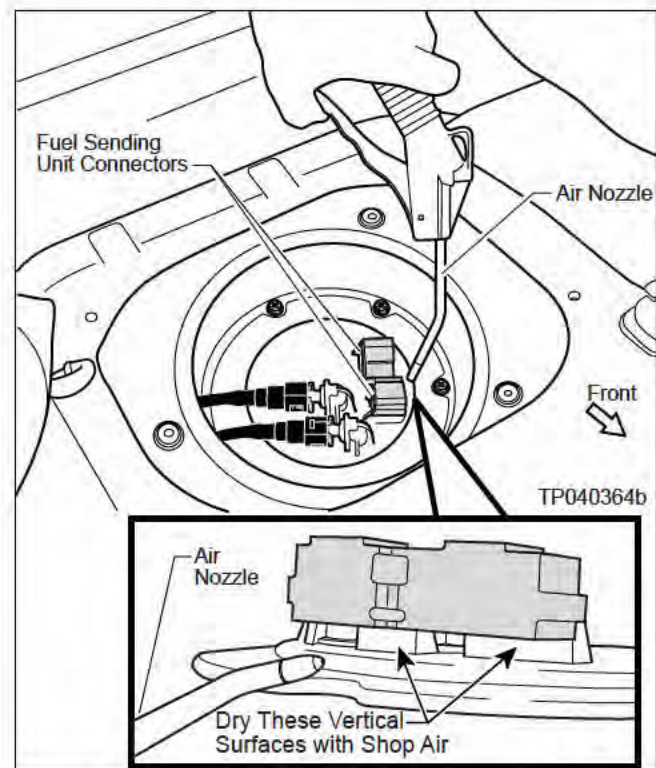
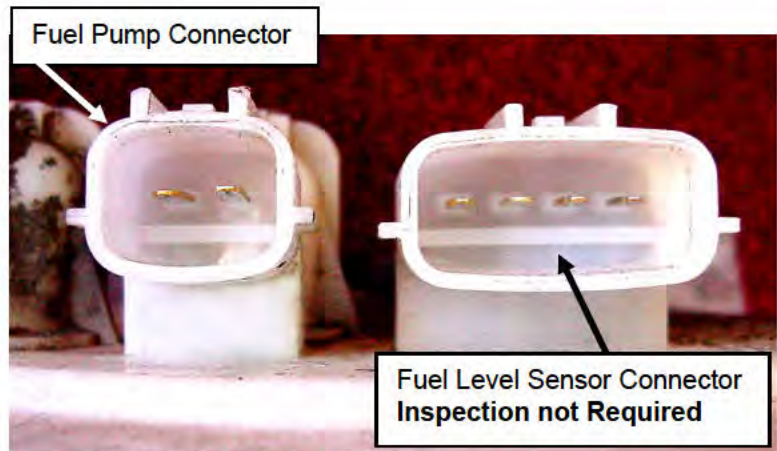

Figure 32

13. Inspect the **Fuel Pump** Connector for green corrosion.

- Inspection is NOT required for the Fuel Level Sensor Connector.
 - Use a mirror to look at the connector.
 - See illustrations below for examples of green corrosion.
- a. If **OK**, go to “Xterra: Add Protective Coating To Fuel Sending Unit” (next page).
- b. If **NG**, go to “Xterra: Replace Fuel Sending Unit” (page 25).

OK
(No Green Corrosion)



NG
(With Green Corrosion)

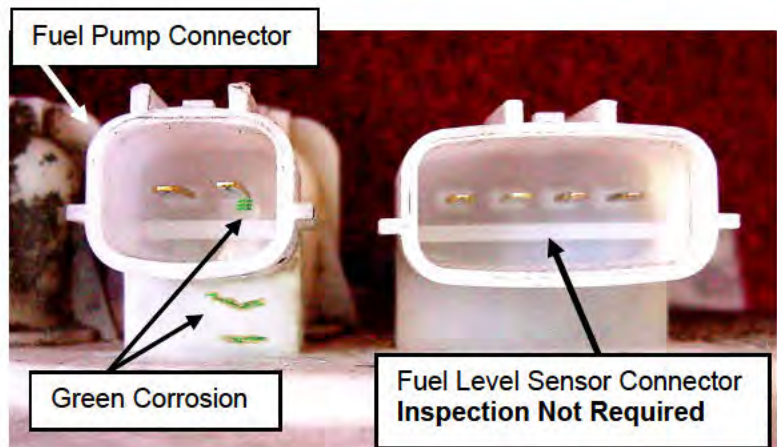

NG
(With Green Corrosion)

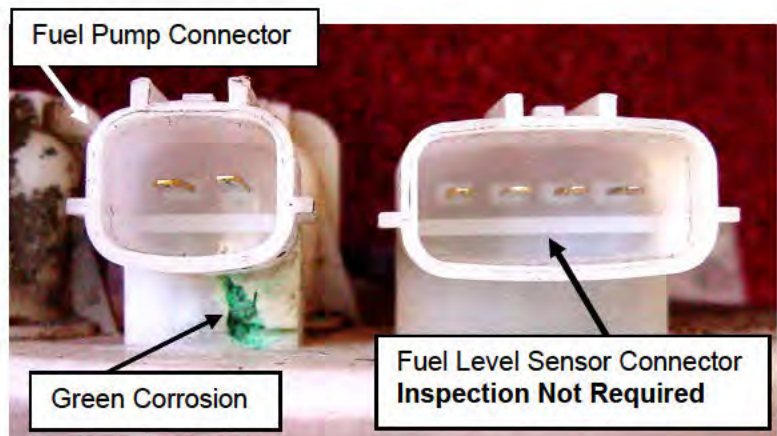

Xterra: Add Protective Coating To Fuel Sending Unit

1. Install the Sealing Adapter (blue color adapter) onto the Fuel Sending Unit Connectors until it clicks (locks) in place. See Figure 33.

CAUTION: When performing the following steps:

- Use suitable protective gloves, safety glasses, or face shield.
- Use suitable covers to protect carpet, upholstery, etc.

2. Shake the Protective Coating can #KY140-9Z400 to thoroughly mix the contents.

3. Spray the Protective Coating #KY140-9Z400 through each Adapter Tube for about two seconds (see Figure 34).

- You will need to attach the Adapter Tube onto the Protective Coating spray can nozzle.
- You do not have to wait for the Protective Coating to dry. Proceed to the next step.

4. Apply Tectyl 517 Wax Sealer to the Fuel Sending Unit Mounting Flange area. Make sure the area is clean and dry before applying the Tectyl 517.

5. Remove/discard the Sealing Adapter.

NOTE:

- When you remove the Sealing Adapter, one or both of the connector inserts may come out of the Adapter.
- Make sure you remove the insert(s) from the Fuel Sending Unit connector(s).

6. Re-connect the Fuel Sending Unit Harness Connectors, making sure they are securely locked into position.

7. Re-assemble all previously removed components in the reverse order you removed them.

- Tighten the Fuel Sending Unit Inspection Cover Bolts snug, being careful not to strip out the plastic inserts.
- Tighten the Body Cover Plate Bolts to **3.7 – 5.0 N-m (0.38 – 0.51 kg-m, 33.0 – 44.3 in-lb)**.

8. Start the vehicle and confirm proper engine running and fuel gauge operation.

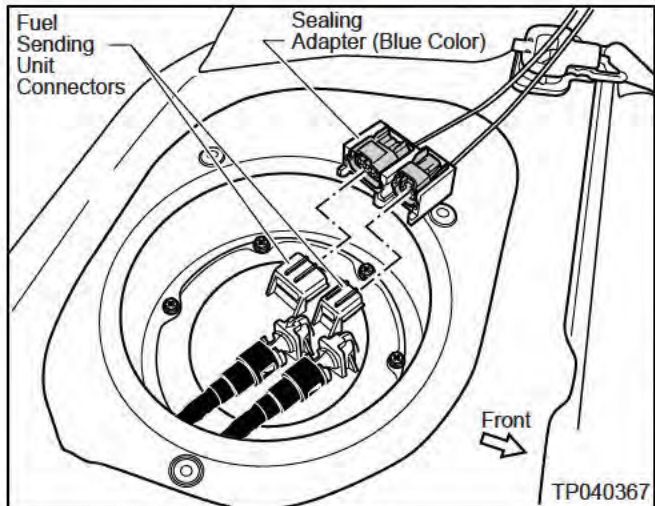

Figure 33

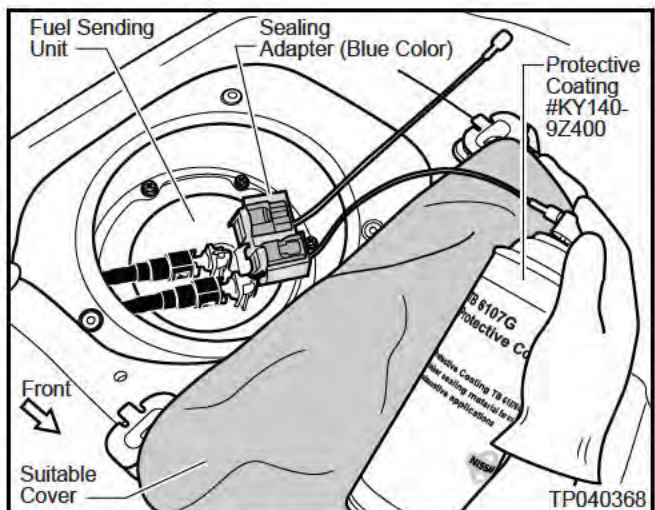

Figure 34

Xterra: Replace Fuel Sending Unit

WARNING:

- Before performing any of the Service Procedures below, be certain there are no ignition sources (i.e., open flames, sparks, etc.) in or around the vehicle/work area.
- Make sure the appropriate rated fire extinguisher is available for immediate use.
- Use suitable protective gloves, safety glasses, or face shield.

CAUTION: Use suitable covers to protect carpet, upholstery, etc.

NOTE: The Fuel Sending Unit that you remove from the vehicle may look different from the new replacement service part (see Figure 43).

1. If the fuel tank is more than $\frac{3}{4}$ full, use a suitable device to remove fuel from the fuel tank until the fuel level is $\frac{3}{4}$ full or less.
2. Release the fuel pressure from the fuel system using CONSULT-II (or other suitable method). **Follow the procedure in the “EC” section of the Service Manual.**
3. Remove the Fuel Sending Unit as follows:

- a. First, use shop air to clean the area around the Fuel Sending Unit and Mounting Flange (see Figure 35).

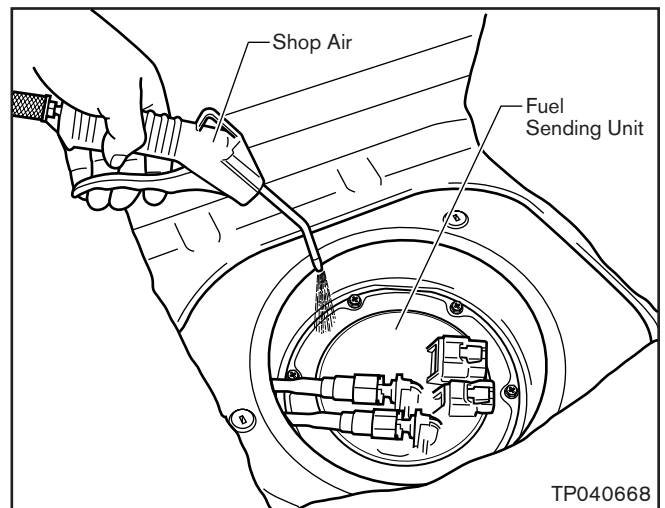

Figure 35

- b. Then, apply Rust Penetrant (999MP-A3020P) to the Fuel Sending Unit Mounting Flange Bolts (see Figure 36). Allow the penetrant to “soak” for a few minutes.

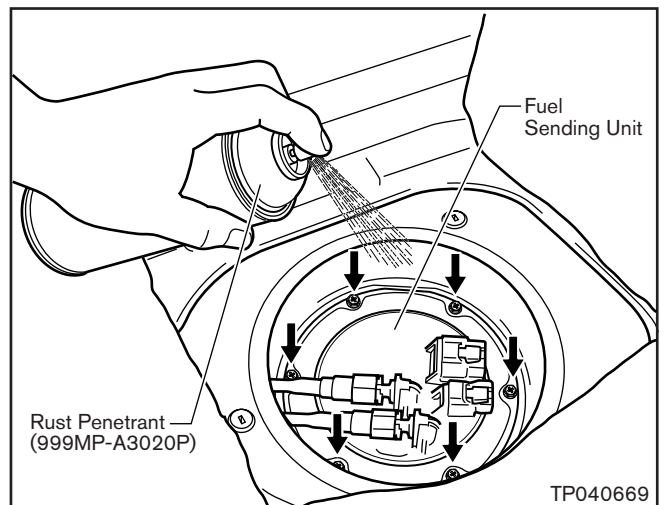

Figure 36

- c. **Using hand tools ONLY**, gently remove the Fuel Sending Unit Mounting Flange Bolts.

4. Remove the Fuel Sending Unit.

NOTE: To disconnect the fuel return hose from the Fuel Sending Unit, do the following:

- Push **UP** on the fuel return hose connector 1 to 2 mm (around 1/16-inch). See Figure 37A.
- With the hose connector pushed **UP**, hold the two plastic tabs. See Figure 37B.
- While holding the plastic tabs, pry **DOWN** on the hose connector with hose removal pliers (such as #47900, Lisle Corporation or equivalent). See Figure 37C.

NOTE: The hose removal pliers (noted above) are available from TECH-MATE at 1-800-662-2001 (option #4).

- Cut and discard the old Fuel Sending Unit O-ring. You'll be installing a new O-ring later.

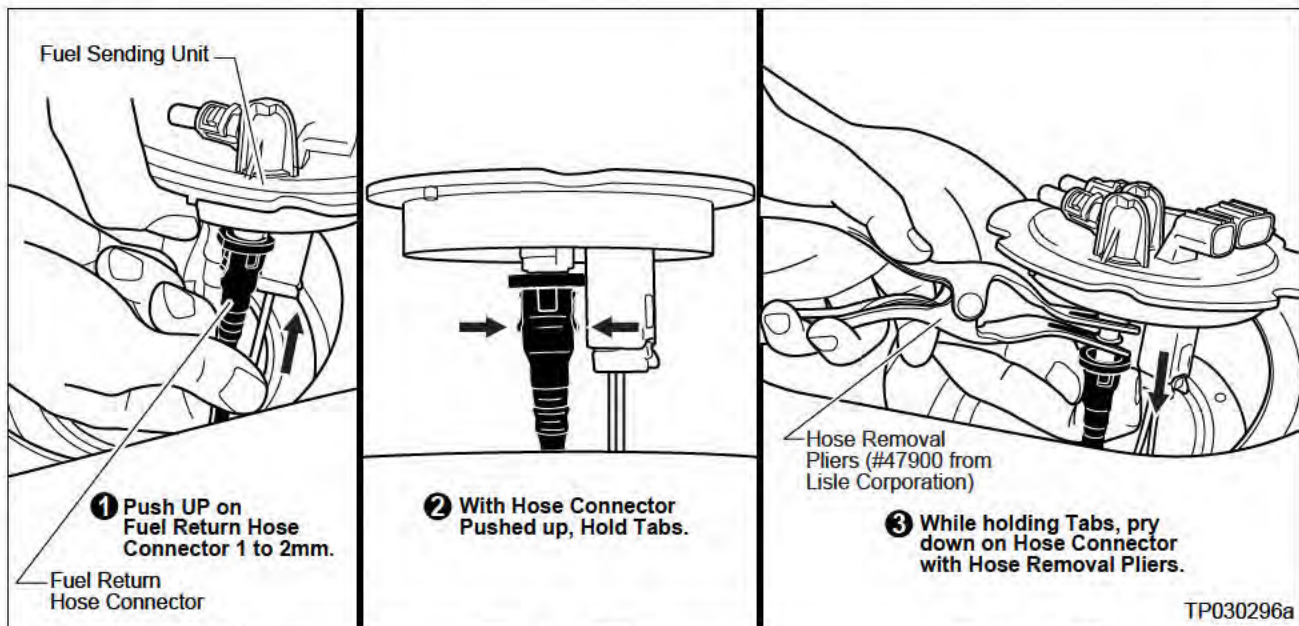

Figure 37A

Figure 37B

Figure 37C

TP030296a

5. Inspect the Fuel Tank Sending Unit Mounting Flange and O-Ring Groove (see Figure 38 and 39).

IF:

- There are no broken bolts on the Mounting Flange.
- The O-Ring groove has NO or light rust (no scaling) and can be cleaned with a light abrasive pad (such as Scotch Brite Pad 3M #051131-07447) or a copper/bronze bristle brush. See Figures 40 & 41.

OK

THEN:

- The Fuel Tank is OK and can be re-used.
- Proceed with step 6.

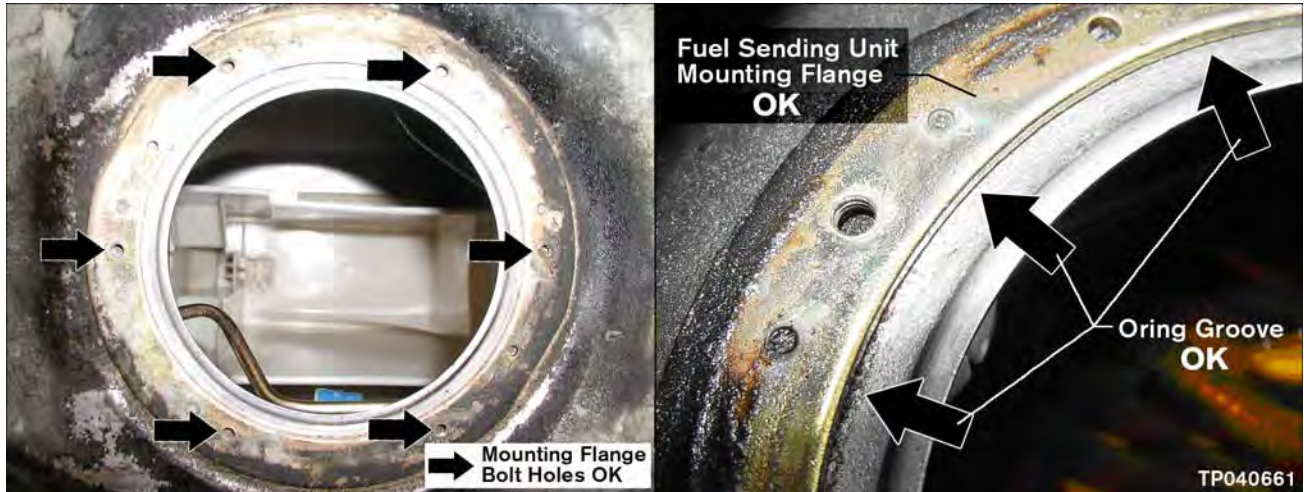

Figure 38

IF:

- There are broken bolts on the Mounting Flange, or
- The O-Ring groove is rusty (scaling) and can NOT be cleaned with a light abrasive pad (such as Scotch Brite Pad 3M #051131-07447) or a copper/bronze bristle brush.

NG

THEN:

- The Fuel Tank is NO GOOD and must be replaced.
- Replace the Fuel Tank, then proceed with Step 9.

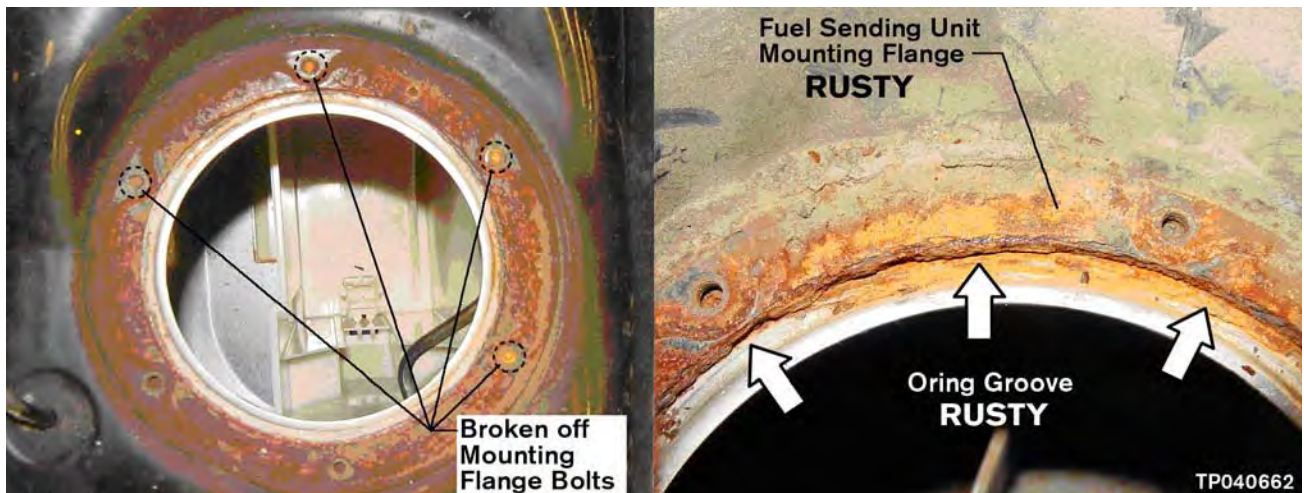

Figure 39

6. Insert the Protective Cover (provided in Kit A or Kit B) in the Fuel Tank opening (see Figure 40).

CAUTION: Make sure the Protective Cover is properly inserted/seated to prevent rust and debris from entering the Fuel Tank.

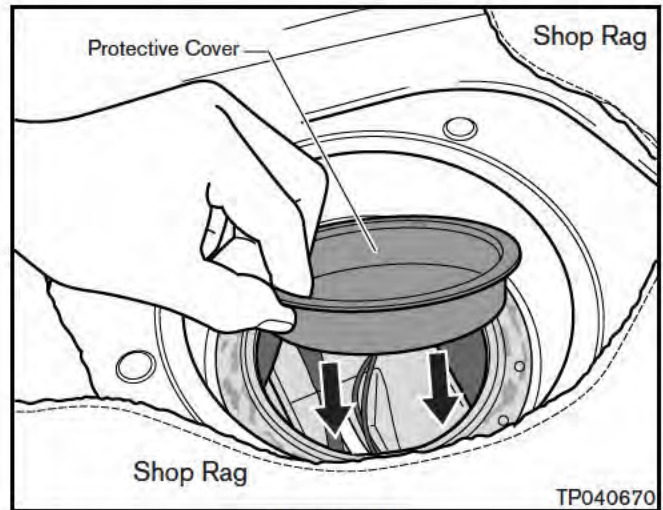

Figure 40

7. Completely clean the Fuel Tank Sending Unit Mounting Flange and O-Ring Groove by hand using Scotch Brite Pad 3M #051131-07447 or a copper/bronze bristle brush. See Figure 41.

WARNING:

- Do NOT use any power tools (pneumatic or electric) for cleaning the Fuel Tank Sending Unit Mounting Flange and O-Ring Groove.
- Use proper care and precaution when working around gasoline.
- Be certain there are no ignition sources (i.e., open flames, sparks, etc.) in or around the vehicle/work area.

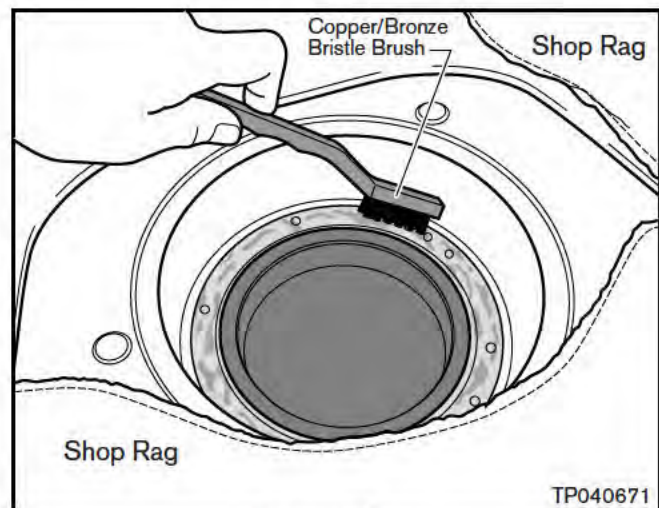

Figure 41

- Make sure the appropriate rated fire extinguisher is available for immediate use.
- Use suitable protective gloves, safety glasses, or face shield.

8. Use shop air to completely blow off/clean the Fuel Tank Sending Unit Mounting Flange and O-Ring Groove.
9. Install the new Fuel Sending Unit O-ring in the groove on the fuel tank.
10. Use the new mounting screws to install the Fuel Sending Unit on the fuel tank. Refer to the "FE" section of the applicable Service Manual.
 - Tighten the Fuel Sending Unit mounting screws to **2.0 – 2.5 N-m (0.20 – 0.26 kg-m, 17.4 – 22.6 in-lb)**.

IMPORTANT: Make sure the Fuel Sending Unit Wire Harness Connectors are securely locked into position.

11. Apply Tectyl 517 (Bitumen) Wax Sealer to the Fuel Sending Unit Mounting Flange area as follows:

a. Completely clean and dry off (with shop air) the Mounting Flange area.

b. Apply **ONLY** Tectyl 517 (Bitumen) Wax Sealer (999MP-9G001P) around the outer edge of the Fuel Sending Unit Mounting Flange (see Figure 42).

- Thoroughly shake the can of Wax Sealer to ensure complete mixing.

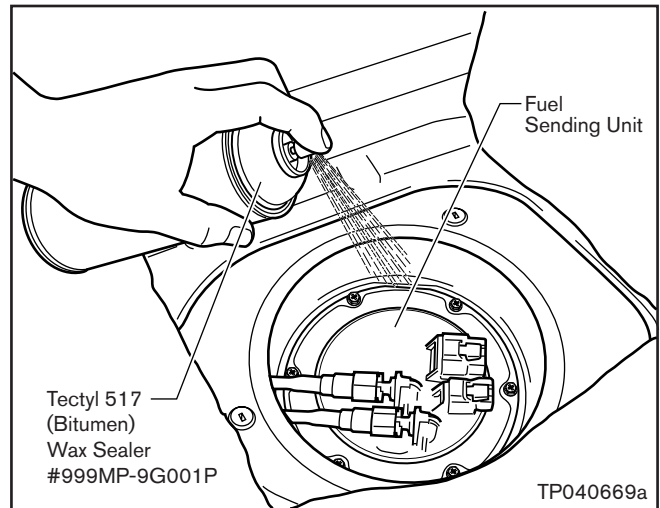

Figure 42

12. Re-assemble all parts you removed before (except the Fuel Sending Unit Inspection Cover and Body Cover) in the reverse order you removed them.

NOTE: Make sure all Fuel/EVAP hoses are in good condition (no cracks, splits, etc.) and are securely reconnected to prevent leaks. Also, make sure the gas cap is installed and securely tightened.

13. Use CONSULT-II to check the Fuel Tank for leaks as follows:

a. Connect CONSULT-II.

b. Turn the ignition key to the **ON** position (with engine off).

c. Select: **Engine, Work Support, EVAP System Close, and Start.**

d. Attach the Vacuum Pump J-42909 to the vehicle's under hood EVAP System service port.

e. Use the Vacuum Pump to pressurize the EVAP System until the bar graph on the CONSULT-II screen reads half.

- If there is **NO** pressure drop before 1 minute elapses (goes by), go to the next step.
- If there is any pressure drop before 1 minute elapses (goes by), recheck all hoses/connections and perform the test again.

NOTE: If you still have a leak, replace the Fuel Tank and go to the next step.

14. Install/tighten the Fuel Sending Unit Inspection Cover Bolts snug, being careful not to strip out the plastic inserts.

15. Install/tighten the Body Cover Plate Bolts to **3.7 – 5.0 N-m (0.38 – 0.51 kg-m, 33.0 – 44.3 in-lb).**

16. Clear any engine diagnosis codes.

17. Start the vehicle and confirm proper engine running and fuel gauge operation.

PARTS INFORMATION

NOTE: The Fuel Sending Unit that you remove from the vehicle may look different from the new replacement service part (see Figure 43).

R0401

DESCRIPTION	PART NUMBER	QUANTITY
Fuel Sending Unit Kit (see “NOTE A”) (D22 vehicles built after 9/1/99 and all WD22)	25060-4S426	1
Kit A (for 1999-00 MY D22)	(see “NOTE B”)	1
Kit B (for 2000-03 D22 & WD22)	(see “NOTE B”)	1
Genuine Nissan Rust Penetrant (see “NOTE C”)	999MP-A3020P	As Needed
Genuine Nissan Tectyl 517 (Bitumen) Wax Sealer (see “NOTE C”)	999MP-9G001P	As Needed
OR		
Fuel Sending Unit Kit (see “NOTE A”) (For D22 vehicles built up to 9/1/99)	25060-4S425	1
Kit A (for 1999-00 MY D22)	(see “NOTE B”)	1
Kit B (for 2000-03 D22 & WD22)	(see “NOTE B”)	1
Genuine Nissan Rust Penetrant (see “NOTE C”)	999MP-A3020P	As Needed
Genuine Nissan Tectyl 517 (Bitumen) Wax Sealer (see “NOTE C”)	999MP-9G001P	As Needed
IF REQUIRED		
Fuel Tank (for 1999-00 MY D22)	17202-7B400	1
Fuel Tank (for 2000 and later D22 4-cyl. & 6-cyl. and WD22 6-cyl. ONLY)	17202-5S620	1
Fuel Tank (for 2000 and later WD22 4-cyl. ONLY)	17202-5S820	1

NOTE A: Kit contains: one Fuel Sending Unit, six Screws, two yellow-green Quick Connectors, one orange Quick Connector, and one O-ring.

NOTE B:

- Order kit by sending an e-mail to campaign.parts@nissan-usa.com When ordering, include your dealer name and number. Also, indicate which kit you want to order (Kit A or Kit B).

NOTE C:

- Order through the Chemical Care Direct Ship Product Program which can be reached by:
Phone; 1 (800) 811-0502
Fax; 1 (770) 218-0148
Internet; www.nissanchemicals.com
- One can of Rust Penetrant / Tectyl 517 Wax Sealer is good for about 20 vehicles

R0402

DESCRIPTION	PART NUMBER	QUANTITY
Cleaning/Sealing Kit	B5060-79900	1 (per vehicle)
Protective Coating (see “NOTE D”)	KY140-9Z400	As Needed
Genuine Nissan Brake Cleaner (see “NOTE E”)	999MP-AH001P	As Needed
OR		
Cleaning/Sealing Kit	B5060-79900	1 (per vehicle)
Fuel Sending Unit Kit (see “NOTE F”) (D22 vehicles built after 9/1/99 and all WD22)	25060-4S426	1
Kit A (for 1999-00 MY D22)	(see “NOTE G”)	1
Kit B (for 2000-03 D22 & WD22)	(see “NOTE G”)	1
Genuine Nissan Rust Penetrant (see “NOTE E”)	999MP-A3020P	As Needed
Genuine Nissan Tectyl 517 (Bitumen) Wax Sealer (see “NOTE E”)	999MP-9G001P	As Needed
OR		
Cleaning/Sealing Kit	B5060-79900	1 (per vehicle)
Fuel Sending Unit Kit (see “NOTE F”) (For D22 vehicles built up to 9/1/99)	25060-4S425	1
Kit A (for 1999-00 MY D22)	(see “NOTE G”)	1
Kit B (for 2000-03 D22 & WD22)	(see “NOTE G”)	1
Genuine Nissan Rust Penetrant (see “NOTE E”)	999MP-A3020P	As Needed
Genuine Nissan Tectyl 517 (Bitumen) Wax Sealer (see “NOTE E”)	999MP-9G001P	As Needed
IF REQUIRED		
Fuel Tank (for 1999-00 MY D22)	17202-7B400	1
Fuel Tank (for 2000 and later D22 4-cyl. & 6-cyl. and WD22 6-cyl. ONLY)	17202-5S620	1
Fuel Tank (for 2000 and later WD22 4-cyl. ONLY)	17202-5S820	1

NOTE D:

- Order from your local Parts Distribution Center (PDC).
- One can of Protective Coating is good for about 40 vehicles.

NOTE E:

- Order through the Chemical Care Direct Ship Product Program which can be reached by:
Phone; 1 (800) 811-0502
Fax; 1 (770) 218-0148
Internet; www.nissanchemicals.com
- One can of Brake Cleaner/Rust Penetrant/Tectyl 517 Wax Sealer is good for about 20 vehicles

NOTE F: Kit contains: one Fuel Sending Unit, six Screws, two yellow-green Quick Connectors, one orange Quick Connector, and one O-ring.

NOTE G:

- Order kit by sending an e-mail to campaign.parts@nissan-usa.com When ordering, include your dealer name and number. Also, indicate which kit you want to order (Kit A or Kit B).

ATTENTION: P/Ns KY140-9Z400, 999MP-AH001P, 999MP-A3020P, and 999MP-9G001P are considered shop supplies – do NOT include them on your warranty claim.

NOTE: The Fuel Sending Unit that you remove from the vehicle may look different from the new replacement service part (see Figure 43).

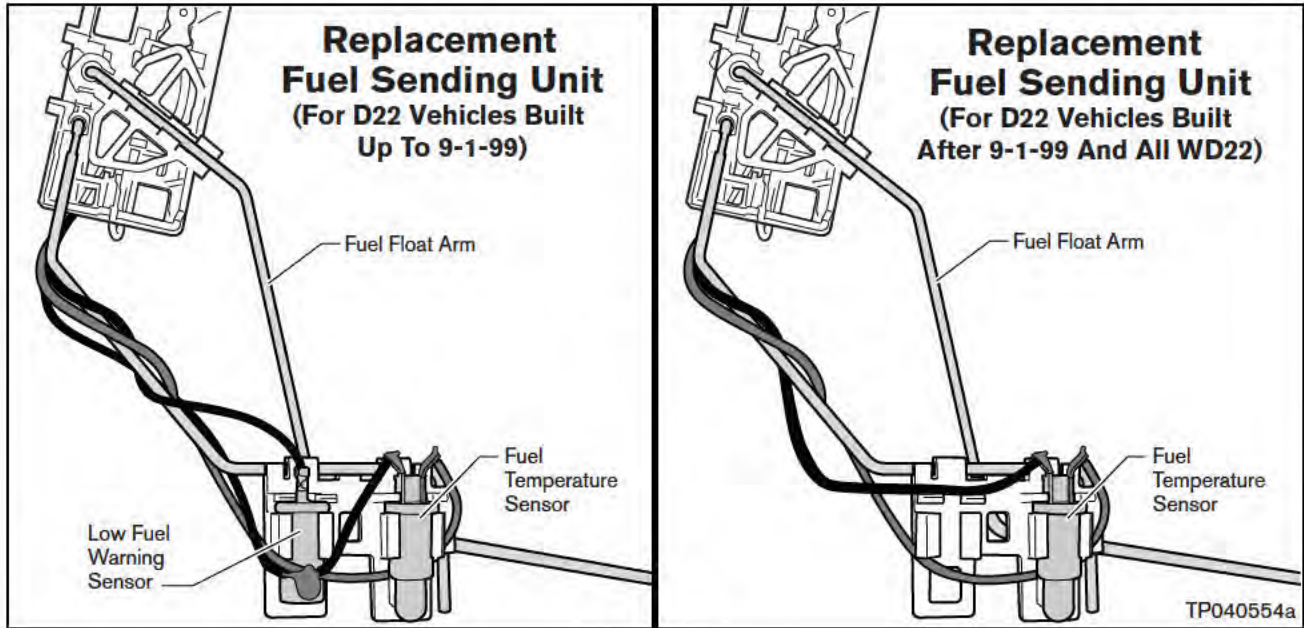

Figure 43

CLAIMS INFORMATION

Submit a Campaign “CM” line claim using the following claims coding information:

Campaign I.D.: **R0401 (Salt States)**

MODEL	DESCRIPTION	OP CODE	FRT
D22	<ul style="list-style-type: none"> Replace Fuel Level Sender Unit Inspect/Clean Mtg. Flange & O-Ring Groove Perform 2 p.s.i. Pressure Leak Test Apply Tectyl 517 (Bitumen) Wax Sealer 	R04012	1.6 hr
	OR, IF REQUIRED		
	<ul style="list-style-type: none"> Replace Fuel Level Sender Unit Replace Fuel Tank Assy. Apply Tectyl 517 (Bitumen) Wax Sealer 	R04013	1.7 hr

WD22	<ul style="list-style-type: none"> Replace Fuel Level Sender Unit Inspect/Clean Mtg. Flange & O-Ring Groove Apply Tectyl 517 (Bitumen) Wax Sealer Perform CONSULT-II EVAP OBD-II Test 	R04014	0.9 hr
	OR, IF REQUIRED		
	<ul style="list-style-type: none"> Replace Fuel Level Sender Unit Replace Fuel Tank Assy. Apply Tectyl 517 (Bitumen) Wax Sealer 	R04015	1.6 hr

ATTENTION: P/Ns KY140-9Z400, 999MP-AH001P, 999MP-A3020P, and 999MP-9G001P are considered shop supplies – do NOT include them on your warranty claim.

Campaign I.D.: R0402 (Non-Salt States)

MODEL	DESCRIPTION	OP CODE	FRT
D22	<ul style="list-style-type: none"> Clean, Inspect, and Seal Fuel Level Sender Unit 	R04020	0.5 hr
	OR, IF REQUIRED		
	<ul style="list-style-type: none"> Clean, Inspect, and Replace Fuel Level Sender Unit Inspect/Clean Mtg. Flange & O-Ring Groove Perform 2 p.s.i. Pressure Leak Test Apply Tectyl 517 (Bitumen) Wax Sealer 	R04024	1.8 hr
	<ul style="list-style-type: none"> Clean, Inspect, and Replace Fuel Level Sender Unit Replace Fuel Tank Assy. Apply Tectyl 517 (Bitumen) Wax Sealer 	R04026	1.9 hr

WD22	<ul style="list-style-type: none"> Clean, Inspect, and Seal Fuel Level Sender Unit 	R04021	0.4 hr
	OR, IF REQUIRED		
	<ul style="list-style-type: none"> Clean, Inspect, and Replace Fuel Level Sender Unit Inspect/Clean Mtg. Flange & O-Ring Groove Apply Tectyl 517 (Bitumen) Wax Sealer Perform CONSULT-II EVAP OBD-II Test 	R04025	1.3 hr
	<ul style="list-style-type: none"> Clean, Inspect, and Replace Fuel Level Sender Unit Replace Fuel Tank Assy. Apply Tectyl 517 (Bitumen) Wax Sealer 	R04027	1.9 hr

ATTENTION: P/Ns KY140-9Z400, 999MP-AH001P, 999MP-A3020P, and 999MP-9G001P are considered shop supplies – do NOT include them on your warranty claim.

ThreeBond

Material Safety Data Sheet

Section 1. Chemical Product and Company Identification			
Common Name	TB 6107G	Code	3TB-20-0483
Supplier	Three Bond International, Inc. 6184 Schumacher Park Drive West Chester, OH 45069	MSDS#	0118-12-03
		Validation Date	4/14/2004
Synonym	Not available.	Print Date	4/14/2004
Trade name	TB 6107G	Responsible Name	Company
Material Uses	Aerosol Coating.	In Case of Emergency Monday-Friday, 830-500pm, 513-779-7300 EST. CHEMTREC - 1-800-424-9300 - 24 hours.	
Manufacturer	ThreeBond Co., Ltd. 1456 Hazama-cho Hachioji-shi, Tokyo 193-8533, Japan		

Section 2. Composition, Information on Ingredients			
Name	CAS #	% by Weight	Exposure Limits
1) Non-hazardous material		23-43	Not applicable.
2) Dimethyl ether (propellant)	115-10-6	30-40	TWA: 1000 (ppm) from DFG MAKs
3) Ethyl acetate	141-78-6	10-20	TWA: 400 (ppm) from OSHA (PEL) [United States] NIOSH IDLH: 2000 ppm LEL
4) Toluene	108-88-3	15-25	TWA: 200 (ppm), Ceiling: 300 ppm, 500 ppm (10-minute maximum peak) from OSHA TWA: 100 (ppm) from NIOSH, STEL 150 ppm, NIOSH IDLH: 500 ppm TWA: 50 (ppm) from ACGIH (TLV) (skin) [United States]
5) Carbon Black	1333-86-4	1.5-2.5	TWA: 3.5 (mg/m ³) from ACGIH (TLV) [United States] TWA: 3.5 (mg/m ³) from OSHA (PEL) [United States]
6) 2-Butoxyethanol	111-76-2	1-2.5	TWA: 50 (ppm) from OSHA (PEL)(skin) [United States] TWA: 5 (ppm) from NIOSH (skin), IDLH: 700 ppm TWA: 20 (ppm) from ACGIH (TLV) (skin), STEL: 121(mg/m ³) [United States]

Section 3. Hazards Identification	
Physical State and Appearance	Aerosol
Emergency Overview	<p>WARNING!</p> <p>Flammable aerosol. Keep away from sources of heat, sparks, or flames. May be harmful if inhaled or swallowed. "Keep away from food." Causes eye irritation. May cause respiratory tract and skin irritation. Possible birth defect hazard. Contains material which causes damage to the following organs: blood, kidneys, liver, bladder, brain, skin, eyes, central nervous system.</p> <p>Avoid contact with eyes, skin and clothing. Do not ingest. Avoid breathing vapor or mist. Keep container closed. Use only with adequate ventilation. Avoid exposure during pregnancy. Wash thoroughly after handling.</p>
Routes of Entry	Absorbed through skin. Dermal contact. Eye contact. Inhalation. Ingestion.
Potential Acute Health Effects	<p>Eyes Eye irritant. Inflammation characterized by pain, redness, and/or blurred vision.</p> <p>Skin MAY BE ABSORBED (see inhalation). Skin irritant. Skin inflammation is characterized by dry skin and redness. Propellant (methyl ether) as a liquid, may cause frost bite on contact with skin.</p>
Continued on Next Page	

TP040436

Inhalation	Exposure above OEL may cause death, see IDLH in Section 2. Respiratory irritant. May cause effects to central nervous system. Symptoms include cough, sore throat, confusion, drowsiness, dizziness, headache, nausea, weakness, and unconsciousness.
Ingestion	May be fatal if swallowed.
Potential Chronic Health Effects	Repeated or prolonged contact with skin may cause dermatitis or may defat the skin. Long term or repeated exposure may have effect on central nervous system, resulting in decreased learning ability and psychological disorders. Contains Carbon Black which is Classified 2B (Possible for human.) by IARC, but Classified A4 (Not classifiable for human or animal.) by ACGIH and not classified by OSHA. Contains Toluene which is a suspected teratogen for humans.
Medical Conditions Aggravated by Overexposure:	Repeated exposure to a highly toxic material may produce general deterioration of health by an accumulation in one or many human organs.
Overexposure /Signs/Symptoms	Not available.
See Toxicological Information (section 11)	

Section 4. First Aid Measures

Eye Contact	In case of contact, immediately flush eyes with plenty of water for at least 15 minutes. If easily possible, remove contact lenses. Get medical attention immediately.
Skin Contact	Remove contaminated clothes. Rinse skin with plenty of water or shower. Then wash skin with water and soap. Refer to medical attention.
Inhalation	If inhaled, remove to fresh air. If not breathing, give artificial respiration. If breathing is difficult, give oxygen. Get medical attention.
Ingestion	Rinse mouth. In case of ingestion of large amounts give slurry of activated charcoal in water to drink. Do NOT induce vomiting. Immediately refer to medical attention.
Notes to Physician	Not available.

Section 5. Fire Fighting Measures

Flammability of the Product	Flammable.
Auto-Ignition Temperature	The lowest known value is 238°C (460.4°F) (2-Butoxyethanol).
Flash Points	<0°C (propellant)
Flammable Limits	The greatest known range is LOWER: 1.1% UPPER: 12.7% (2-Butoxyethanol)
Products of Combustion	These products are carbon oxides (CO, CO ₂).
Fire Hazards in Presence of Various Substances	Flammable in presence of open flames and sparks.
Explosion Hazards in Presence of Various Substances	Closed containers may explode (due to build-up pressure) when exposed to extreme heat. Isolate from heat, electrical equipment, sparks, and flame.
Fire Fighting Media and Instructions	SMALL FIRE: Shut off supply; if possible let fire burn itself out; in other cases use DRY chemical powder, carbon dioxide. LARGE FIRE: Use water spray, fog or alcohol resistant foam. Do not use water jet. Keep containers cool by spraying with water.
Protective Clothing (Fire)	Full protective equipment including self contained breathing apparatus should be used.
Special Remarks on Fire Hazards	Vapors may form explosive mixtures with air. This material is flammable and may be ignited by heat, sparks, flames, or other sources of ignition such as static electricity, pilot lights, and mechanical/electrical equipment. Vapors may travel considerable distances to a source of ignition where they can ignite, flashback, or explode. May create vapor/air explosion hazard indoors, outdoors, or sewers. Vapors are heavier than air and can accumulate in low areas. May polymerize explosively when heated or involved in fire.
Special Remarks on Explosion Hazards	Container explosion may occur under fire conditions.

Continued on Next Page

Section 6. Accidental Release Measures

Small Spill and Leak	Absorb with an inert material and put the spilled material in a sealable container. Do not wash away into sewer. Extinguish all ignition sources and ventilate area. Wear protective equipment during clean-up.
Large Spill and Leak	Evacuate danger area. Consult an expert. Remove all ignition sources.

Section 7. Handling and Storage

Handling	Keep away from heat, sparks, and open flames. Do not puncture, incinerate, or expose to high temperatures. Avoid contact with eyes, skin and clothing. Do not ingest. Avoid breathing vapors or spray mists. Keep container closed. Use only with adequate ventilation. Wash thoroughly after handling.
Storage	Keep in fireproof, cool area that is separate from strong oxidants.

Section 8. Exposure Controls, Personal Protection

Engineering Controls	Provide exhaust ventilation or other engineering controls to keep the airborne concentrations of vapors below their respective threshold limit value. Ensure that eyewash stations and safety showers are proximal to the work-station location.
-----------------------------	--

Personal Protection	<p>Eyes Splash goggles.</p> <p>Body Long sleeves work apparel must be worn. Depending on conditions of use, solvent resistant plastic or rubber apron should be worn.</p> <p>Respiratory Vapor respirator. Be sure to use an approved/certified respirator or equivalent. Wear appropriate respirator when ventilation is inadequate.</p> <p>Hands Gloves.</p> <p>Feet Safety shoes. Chemical resistant shoes.</p>
----------------------------	---

Protective Clothing (Pictograms)



Personal Protection in Case of a Large Spill	Splash goggles. Full suit. Boots. Gloves. A self-contained breathing apparatus should be used to avoid inhalation of the product. Suggested protective clothing might not be sufficient; consult a specialist BEFORE handling this product.
---	---

Product Name	Exposure Limits
1) Non-hazardous material	Not applicable.
2) Dimethyl ether	TWA: 1000 (ppm) from DFG MAKs
3) Ethyl Acetate	TWA: 400 (ppm) from OSHA (PEL) [United States] NIOSH IDLH: 2000 ppm LEL
4) Toluene	TWA: 200 (ppm), Ceiling: 300 ppm, 500 ppm (10-minute maximum peak) from OSHA TWA: 100 (ppm) from NIOSH, STEL 150 ppm, NIOSH IDLH: 500 ppm
5) Carbon Black	TWA: 50 (ppm) from ACG H (TLV) (skin) [United States] TWA: 3.5 (mg/m ³) from ACGIH (TLV) [United States] TWA: 3.5 (mg/m ³) from OSHA (PEL) [United States]
6) 2-Butoxyethanol	TWA: 50 (ppm) from OSHA (PEL)(skin) [United States] TWA: 5 (ppm) from NIOSH (skin), IDLH: 700 ppm TWA: 20 (ppm) from ACG H (TLV) (skin), STEL: 121(mg/m ³) [United States]

Consult local authorities for acceptable exposure limits.

Continued on Next Page

Section 9. Physical and Chemical Properties

Physical State and Appearance	Aerosol	Odor	ether-like odor
Molecular Weight	Not applicable.	Taste	Not available.
Molecular Formula	Not applicable.	Color	Black
pH (1% Soln/Water)	Not available.		
Boiling/Condensation Point	Not available.		
Melting/Freezing Point	Not available.		
Critical Temperature	Not available.		
Specific Gravity	1.1		
Vapor Pressure	Not available.		
Vapor Density	Not available.		
Volatility	Not available.		
Odor Threshold	Not available.		
Evaporation Rate	Not available.		
VOC	Not available.		
Viscosity	1.9		
LogK_{ow}	Not available.		
Ionicity (in Water)	Not available.		
Dispersion Properties	Is not dispersed in cold water, hot water.		
Solubility	Insoluble in cold water, hot water.		
Physical Chemical Comments	Not available.		

Section 10. Stability and Reactivity

Stability and Reactivity	The product is stable.
Conditions of Instability	Heating may cause violent combustion or explosion.
Incompatibility with Various Substances	Reactive with oxidizing agents, acids. Slightly reactive to reactive with alkalis, moisture.
Hazardous Decomposition Products	Not available.
Hazardous Polymerization	Not available.

Section 11. Toxicological Information

Toxicity to Animals	Acute oral toxicity (LD50): 50 mg/kg [Human/30 min]. (Toluene).
Chronic Effects on Humans	Repeated or prolonged contact with skin may cause dermatitis or may defat the skin. Long term or repeated exposure may have effect on central nervous system, resulting in decreased learning ability and psychological disorders. Contains Carbon Black which is Classified 2B (Possible for human.) by IARC, but Classified A4 (Not classifiable for human or animal.) by ACGIH and not classified by OSHA. Contains Toluene which is a suspected teratogen for humans.

Continued on Next Page

Other Toxic Effects on Humans	Hazardous in case of skin contact (irritant), of inhalation (lung irritant). May be fatal if ingested.
Special Remarks on Toxicity to Animals	Overexposure to Toluene has been suggested as a cause of the following in the animal laboratory: mild, reversible liver effects, cardiac sensitization, respiratory track damage (nose, throat and airways), effects on hearing, central nervous system damage.
Special Remarks on Chronic Effects on Humans	(Sh) MAK - Danger of sensitization of the skin. (Toluene)
Special Remarks on Other Toxic Effects on Humans	May cause irritation to skin, eyes and respiratory tract.

Section 12. Ecological Information

Ecotoxicity	Not available.
BOD5 and COD	Not available.
Biodegradable/OECD	Not available.
Mobility	Not available.
Products of Degradation	These products are carbon oxides (CO, CO2) and water.
Toxicity of the Products of Biodegradation	The products of degradation are less toxic than the product itself.
Special Remarks on the Products of Biodegradation	Not available.

Section 13. Disposal Considerations

Waste Information	Waste must be disposed of in accordance with federal, state and local environmental control regulations.
Waste Stream	Not available.
Consult your local or regional authorities.	

Section 14. Transport Information

DOT Classification	Consumer Commodity (not more than 500 ml); other, Aerosols/Flammable, Class 2.1, UN1950	
	Aerosol, Flammable, Class 2.1, UN1950	
Marine Pollutant	Not available.	
Special Provisions for Transport	Not Available.	
ADR/RID Classification	CLASS 2.1: Flammable gas. CLASS 6.1: Toxic substance.	
IMO/IMDG Classification	CLASS 2.1: Flammable gas. CLASS 6.1: Toxic substance.	
ICAO/IATA Classification	CLASS 2.1: Flammable gas. CLASS 6.1: Toxic substance.	

Continued on Next Page

Section 15. Regulatory Information

HCS Classification	HCS Class: Flammable aerosol. CLASS: Highly toxic. CLASS: Target organ effects. CLASS: Reproductive toxins.
U.S. Federal Regulations	TSCA 8 (b) inventory: All ingredients of this product are in compliance with TSCA requirements. SARA 302/304/311/312 extremely hazardous substances: No products were found. SARA 302/304 emergency planning and notification: No products were found. SARA 302/304/311/312 hazardous chemicals: Di 2-Ethylhexyl phthalate [DEHP]; Toluene; 2-Butoxyethanol SARA 311/312 MSDS distribution - chemical inventory - hazard identification: Carbon Black: delayed health hazard; Toluene: fire, immediate health hazard, delayed health hazard SARA 313 toxic chemical notification and release reporting: Toluene 20%; 2-Butoxyethanol 1.75% Clean Water Act (CWA) 307: No products were found. Clean Water Act (CWA) 311: No products were found. Clean air act (CAA) 112 accidental release prevention: Di 2-Ethylhexyl phthalate [DEHP] Clean air act (CAA) 112 regulated flammable substances: Toluene; Ethyl acetate Clean air act (CAA) 112 regulated toxic substances: Dimethyl ether
International Regulations	
EINECS	Not available.
DSCL (EEC)	R12- Extremely flammable. R20/22- Harmful by inhalation and if swallowed. R37/38- Irritating to respiratory system and skin. R40- Possible risks of irreversible effects. R41- Risk of serious damage to eyes.
International Lists	Australia: Carbon Black Korea (TCCL): Carbon Black
State Regulations	Pennsylvania RTK: Di 2-Ethylhexyl phthalate [DEHP] Minnesota: Di 2-Ethylhexyl phthalate [DEHP] Massachusetts RTK: Di 2-Ethylhexyl phthalate [DEHP] New Jersey: Carbon Black; Di 2-Ethylhexyl phthalate [DEHP] Louisiana RTK reporting list: Carbon Black California prop. 65: This product contains the following ingredients for which the State of California has found to cause birth defects which would require a warning under the statute: Toluene

Section 16. Other Information

Label Requirements	Flammable aerosol. Keep away from sources of heat, sparks, or flames. May be harmful if inhaled or swallowed. "Keep away from food." Causes eye irritation. May cause respiratory tract and skin irritation. Possible birth defect hazard. Contains material which causes damage to the following organs: blood, kidneys, liver, bladder, brain, skin, eyes, central nervous system.													
Hazardous Material Information System (U.S.A.)	<table border="1"> <tr> <td>Health</td> <td>*</td> <td>2</td> </tr> <tr> <td>Fire Hazard</td> <td></td> <td>3</td> </tr> <tr> <td>Reactivity</td> <td></td> <td>1</td> </tr> <tr> <td>Personal Protection</td> <td></td> <td>h</td> </tr> </table>	Health	*	2	Fire Hazard		3	Reactivity		1	Personal Protection		h	National Fire Protection Association (U.S.A.) 
Health	*	2												
Fire Hazard		3												
Reactivity		1												
Personal Protection		h												
References	Not available.													
Other Special Considerations	Not available.													
Validated by Company on 4/14/2004.	Verified by Company.													
	Printed 4/14/2004.													
Monday-Friday, 830-500pm, 513-779-7300 EST. CHEMTREC - 1-800-424-9300 - 24 hours.														

Continued on Next Page

Notice to Reader

To the best of our knowledge, the information contained herein is accurate. However, neither the above named supplier nor any of its subsidiaries assumes any liability whatsoever for the accuracy or completeness of the information contained herein.

Final determination of suitability of any material is the sole responsibility of the user. All materials may present unknown hazards and should be used with caution. Although certain hazards are described herein, we cannot guarantee that these are the only hazards that exist.

OWNER'S LETTER

Dear Nissan owner:

This notice is sent to you in accordance with the requirements of the National Traffic and Motor Vehicle Safety Act. Nissan has decided that a defect that relates to motor vehicle safety exists in some 1999-2003 model year Nissan Frontier vehicles equipped with a six cylinder engine and in some 2000-2003 model year Nissan Xterra vehicles equipped with a four or six cylinder engine.

Reason for Recall

The fuel pump terminal on the fuel-sending unit may develop a crack in its plastic molding which could cause the terminal strip to corrode under some environmental conditions. If corrosion occurs, the terminal strip could eventually break. This will cause the fuel pump to stop operating and will result in not being able to start the engine or cause the engine to stop running during vehicle operation, which could result in a crash without warning.

What Nissan Will Do

In the states shown in the table below, where there is heavy use of road salt in the winter and corrosion is likely to occur, the dealer will replace the fuel-sending unit. In the other states, the dealer will inspect the fuel pump terminal on the sending unit for corrosion. If corrosion is present, the dealer will replace the fuel-sending unit. If there is no corrosion, the dealer will apply sealant to the terminal housing to help prevent corrosion in the future. This free service should take about two hours to complete, but your Nissan dealer may require your vehicle for a longer period of time based upon the dealer's work schedule.

Connecticut	Kentucky	New Hampshire	Tennessee
Delaware	Maine	New Jersey	Vermont
District of Columbia	Maryland	New York	Virginia
Illinois	Massachusetts	Ohio	West Virginia
Indiana	Michigan	Pennsylvania	Wisconsin
Iowa	Minnesota	Rhode Island	

What You Should Do

Contact your Nissan dealer at your earliest convenience in order to arrange an appointment to have your vehicle repaired. Please bring this notice with you when you keep your service appointment. **It will be necessary that your fuel tank be no more than one-quarter full when you bring your vehicle to the dealer in order to minimize the possibility of fuel spill during the repair.**

Instructions have been sent to your Nissan dealer. If the dealer fails, or is unable to make the necessary repairs free of charge, you may contact the National Consumer Affairs Office, Nissan North America, Inc. at P.O. Box 191, Gardena, California 90248-0191. The toll free number is 1-800-NISSAN1 (1-800-647-7261). You may also contact the Administrator of the National Highway Traffic Safety Administration, 400 Seventh Street SW, Washington, D.C. 20590 or call the toll free Safety Hotline at (888) 327-4236.

If you have paid to have a fuel-sending unit replaced prior to this campaign, you may be eligible for reimbursement of the related expense. Contact Nissan Consumer Affairs at the number listed above for additional information on how to obtain a reimbursement.

Federal regulations require that any vehicle lesser receiving this recall notice must forward a copy of this notice to the lessee within ten days.

Thank you for your cooperation. We are indeed sorry for any inconvenience this may cause you.

S E R V I C E - C O M M

04/12/13 16:21:14

CICSWB08

FIVE YEARS CLAIM HISTORY

WARRANTY CLAIM DATA

RO DATE: 06/10/06 RO NBR: *9096A SERVICING DEALER: TIM DAHLE NISSAN OF SANDY
MILEAGE: 43,454 SANDY UT 84070

VIN: 5N1ED28Y31C

PNC: R0402 W/D22 FUEL SENDR-NON-SALT ST
SUBLET: 0.00
OPERATIONS: R04021 INSP & RESEAL WD22 FUEL LEVE

PARTS REPLACED:

B506079900 SEALER KIT-FUEL SENDER

ENTER = CONTINUE N = NEXT VEHICLE M = RETURN TO SERVICE-COMM MENU>

CAMPBELL NELSON
24325 HWY 99
EDMONDS, WA. 98026
425-774-2174

154015

Campbell Nelson

24325 Highway 99



Merchant ID: 8013926349
Term ID: 0075420000013928349001

Sale

XXXXXXXXXX [REDACTED]
VISA Entry Method: Swiped

Total: \$ 525.99

04/09/13 16:51:36

Inv #: 154015 Appr Code: 213913

Apprvd: Online

Customer Copy

THANK YOU!

CUSTOMER #: 122859

154015

Campbell Nelson

24325 Highway 99
Edmonds, WA 98026
(425) 774-2174



INVOICE

PAGE 1

WA [REDACTED]
HOME: [REDACTED] CONT:N/A
BUS: [REDACTED] CELL:

SERVICE ADVISOR: 800 ROBERT J NELSON

COLOR	YEAR	MAKE/MODEL	VIN	LICENSE	MILEAGE IN / OUT	TAG	
SILVER	01	NISSAN XTERRA	5N1ED28Y310 [REDACTED]		87128/87131	T726	
DEL DATE	PROD DATE	WARR EXP	PROMISED	PO NO	RATE	PAYMENT	INV DATE
08APR13 DD			17:00 08APR13			CASH	09APR13
R.O. OPENED	READY	OPTIONS: ENG:3.3_Liter_EFI_SOHC					
08:01 08APR13	11:24 09APR13						

LINE	OPCODE	TECH	TYPE	HOURS	LIST	NET	TOTAL
------	--------	------	------	-------	------	-----	-------

A C/S THE VEHICLE WILL STALL OUT AT RANDOM AND NOW THE CAR WILL NOT START

100 FOUND NO FUEL PRESSURE DUE TO THE FUEL SENDER UNIT- REPLACED FUEL SENDER UNIT AND CONFIRMED REPAIR

403 CNR

1	25060-4S415 SENDER UNIT FUE	104.46	104.46	330.00	330.00
1	17342-01A00 RING-O FUEL GAG	22.80	22.80	22.80	22.80

EST: 132.00 08APR13 08:01 SA: 800

CUSTOMER PAY SHOP CHARGE FOR REPAIR ORDER 23.10

* YOUR SATISFACTION IS OUR #1 PRIORITY *

* IF YOU ARE NOT COMPLETELY SATISFIED *

* WITH YOUR RECENT SERVICE WORK PLEASE *

* NOTIFY US IMMEDIATELY. A SURVEY GRADING *

* OUR PERFORMANCE WILL BE MAILED TO YOU *

SIGNATURE COPY

Parts and labor warranted for 12 months or 12,000 miles, whichever occurs first on all Nissan parts.

"HAZARDOUS WASTE DISPOSAL & SHOP SUPPLIES"

This charge is for disposal of hazardous waste generated by the repair of your vehicle. This charge of the disposal of hazardous waste is the result of Federal & State mandated waste regulations. These products include, but are not limited to petroleum products, engine antifreeze, asbestos materials, various solvents and other products used in the dealership that are designated as hazardous materials.

A charge equivalent to 7% of the labor charge is included for supplies used on your vehicle. Maximum charge \$24.63.

I hereby authorize the repair work herein set forth to be done along with necessary material and agree that you are not responsible for loss or damage to vehicle or articles left in vehicle in case of fire, theft, or any other cause beyond your control or for any delays caused by unavailability of parts shipments by the supplier or transporter. I hereby grant you and/or your employees permission to operate the vehicle herein described on streets, highways or elsewhere for the purpose of testing and/or inspection. An express mechanic's lien is hereby acknowledged on above vehicle to secure the amount of repairs thereto.

ACKNOWLEDGED RECEIPT OF VEHICLE AND I HAVE RECEIVED A COPY OF THIS INVOICE.

X _____
CUSTOMER SIGNATURE

DESCRIPTION	TOTALS
LABOR AMOUNT	330.00
PARTS AMOUNT	127.26
GAS, OIL, LUBE	0.00
SUBLET AMOUNT	0.00
MISC. CHARGES	23.10
TOTAL CHARGES	480.36
LESS INSURANCE	0.00
SALES TAX	45.63
PLEASE PAY THIS AMOUNT	525.99



U.S. Department
of Transportation

National Highway
Traffic Safety
Administration

DOT Auto Safety Hotline
Vehicle Owner's Questionnaire
To Report Vehicle Safety Defects
1-888-DASH-2-DOT
(1-888-327-4236)
INTERNET:www.nhtsa.dot.gov/hotline

FOR AGENCY USE ONLY 100148

Date Received

26-APR-2013

Repository

Reference No.
10509699

OWNER INFORMATION (Type or Print)

Name [REDACTED]

Address [REDACTED]

City SEATTLE

State WA

Zip Code [REDACTED]

Daytime Telephone Number

[REDACTED]

E-mail Address

[REDACTED]

Evening Telephone Number

[REDACTED]

The information you provide will be used to identify potential safety-related defects. We may share your information with the applicable vehicle manufacturer during an investigation or recall in accordance with the routine uses described in the agency's Privacy Act notice. See 49 FR 53971 (Sep. 3, 2004).

VEHICLE INFORMATION

17 digit Vehicle Identification Number Located at bottom of windshield on driver's side

5N1ED28Y31C [REDACTED]

Make

NISSAN

Model

XTERRA

Model Year

2001

Date Purchased

Dealer's Name and Telephone Number

Engine:

No: Cylinders

Fuel Type:

Original Owner

Dealer's City

State

Zip Code

Transmission Type

Antilock Brakes

Powertrain

Multiple Failure:

Incident Date(s)

07-APR-2013

Cruise Control

FAILED COMPONENT(S)/PART(S) INFORMATION

Vehicle Component Code: FUEL/PROPULSION SYSTEM (PWS)

Failure Mileage

87128

Failure Speed

65

ADDITIONAL ITEMS TO BE COMPLETED WHEN REPORTING A TIRE FAILURE

Tire Make

Tire Model (Name or Number)

Tire Size (Example P215/65R15)

DOT No. (Example: DOTM19ABC036)

Original Equipment

Prior Repair

Failure Location:

Tire Component Code

Tire Failure Type:

ADDITIONAL ITEMS TO BE COMPLETED WHEN REPORTING A CHILD SEAT FAILURE

Make:

Date Manufactured:

Model No./Name:

Seat Type:

Installation System:

Child Seat Component Code:

Failed Part:

APPLICABLE INCIDENT INFORMATION

(Please describe in detail the incident(s), Failure(s), Crash(es), and injury(ies).)

Crash

Yes No

Fire

Yes No

Number of Persons Injured

0

Number of Deaths

0

Reported to Police

N

Narrative Description of Incident(S), Crash(es), and Injury(ies).

Please describe (1) events leading up to the failure, (2) failure and its consequences, and (3) what was done to correct the failure; i.e., parts repaired or replaced (and if old part is available).

TL* THE CONTACT OWNS A 2001 NISSAN XTERRA. THE CONTACT STATED THAT WHILE DRIVING 65 MPH, THE VEHICLE STALLED WITHOUT WARNING. THE CONTACT WAS ABLE TO COAST ONTO THE SHOULDER WHERE IT WAS TOWED TO THE DEALER. A DIAGNOSTIC WAS PERFORMED WHICH LOCATED THE FAILURE AT THE FUEL SENDING UNIT. THE CONTACT ALSO STATED THAT NHTSA CAMPAIGN ID NUMBER: 04V230000 (FUEL SYSTEM, GASOLINE), WAS PERFORMED ON THE VEHICLE BUT THE REPAIR DID NOT CORRECT THE FAILURE. THE MANUFACTURER WAS MADE AWARE OF THE FAILURE AND THE VEHICLE WAS TAKEN BACK TO THE DEALER, WHO REPLACED THE FUEL SENDING UNIT AS A REMEDY. THE FAILURE MILEAGE WAS 87,128 AND THE APPROXIMATE CURRENT MILEAGE WAS 87,130.

Include, if available: Police/Fire Department Report, Photos, and Repair Invoice.

ATTACH ADDITIONAL SHEETS IF NECESSARY

The Privacy Act of 1974-Public Law 93-579 This information is requested pursuant to authority vested in the National Highway Traffic Safety Act and subsequent amendments. You are under no obligation to respond to this questionnaire. Your response may be used to assist the NHTSA in determining whether a Manufacturer should take appropriate action to correct a safety defect. If the NHTSA proceeds with administrative enforcement or litigation against a manufacturer, your response, or a statistical summary thereof, may be used in support of the agency's action.

