

CL-10485721-3491
NOV 19 2012

INFORMATION Redacted PURSUANT TO THE FREEDOM OF INFORMATION ACT (FOIA), 5 U.S.C. 552(B)(6)

IMPROTANT

From :

[Redacted]

Charlotte, NC [Redacted]
Owner of 06 Odyssey

Tel# [Redacted]

VIN: 5FNRL38726B [Redacted]

Trim: EX w/Leather & DVD 5
Speed Automatic

Ext. Color: Sage Brush Pearl

Int. Color: Ivory

To,

American Honda Motor Co., Inc.
Honda Automobile Customer Service
Mail Stop 500-2N-7A
1919 Torrance Blvd.
Torrance, CA 90501-2746

Ref : Issue with Rack and Pinion after Steering Pump Repair from Recall.

I would like to withdraw your attention towards a possible manufacturing issue of Rack and Pinion leakage in Honda Odyssey 2006 Model. I own a Honda Odyssey, VIN: 5FNRL38726B [Redacted] (Miles ~ 70K) . I took my VAN for repair after recall was made for steering pump. After sometime, I started having problem with steering during turning. I went to Hendrick Honda Dealer in Charlotte (zip 28277) on 11/10/2012 to get it checked. Dealer told me that there is a leakage in RACK and PINION which would cost me \$1548.16 to get it repaired. I asked dealer that faulty (recall) steering pump was replaced recently which could have caused issue with Rack and Pinion as it is well integrated with steering Pump. I was totally surprised to hear that Honda can not cover it under warranty even if there was a known issue with steering pump and warranty on steering pump was extended until 100K miles. I would like to file a complaint with Honda to look into the issue at the earliest and provide me a solution.

I spent lot on time on internet searching through other customers' complaints and found, many people are having the same issue. Please refer to URL from Edmunds where other customers had complained about the same issue of RACK and PINION leaking after recall repaired was done on Steering Pump. Please refer to this URL for details : <http://townhall-talk.edmunds.com/direct/view/.f176f2a>. I am also attaching highlighted hardcopy along with this letter for your record.

I would like your attention in this matter and provide a solution to my problem. Considering only 70 K miles on my VAN, It does seems, there is some manufacturing defect in Honda Odyssey RACK AND PINION part. It is needless to mention, our society has seen many recalls in auto industry. Eventually companies realize the fact after loss. I hope it has not resulted into any major casualties with other customers.

I am also copying this letter to "National Highway Traffic Safety and Administration(NHTSA)" and request "NHTSA" department to look into the matter and take some corrective action by working with Honda so that customers are not penalized, More importantly save lives of our citizen by avoiding accidents due to faulty part in the Vehicle.

I would be looking for your response in this matter. Appreciate if you could please provide me a complaint number for this issue and more importantly authorize dealer to repair my VAN under warranty as warranty on steering pump was extended until 100K miles after recall repair.

Thanks

[Redacted Signature]

Copy Sent to :

National Highway Traffic Safety Administration
1200 New Jersey Ave., SE
Washington, DC 20590
Auto Safety Hotline (888) 327-4236

MC
11/20/12
TAW

Honda Odyssey Steering Problems

83 messages, Last post on Oct 18, 2012 at 9:42 AM

You are in the [Honda Odyssey](#) Forum.

Your Host is [kcram](#)

What is this discussion about? [Honda Odyssey, Steering, Van](#)

Messages Page 9 of 9

Search this Discussion SEARCH

Go To Msg # GO

« PREVIOUS 1 ... 5 6 7 8 9 NEXT » Last

#74 of 83 Honda Dealer by [boyosan](#)

Jan 12, 2012 (2:39 pm)

I got a recall in the mail about my Honda ~~Odyssey power steering pump~~ in late November 2011. In December 2011 I took it to a local dealer to get it repaired/replaced. On completion, a whining noise could be heard at intervals. I returned to the dealer and asked that they take a look at the problem. They acknowledged the noise and checked their work and claimed that everything was done properly. The noise continued.

In January 2012, I returned again and asked them to check the whining noise. They came back a day later and said I had a leak in the rack and pinion rack and the cost to repair is \$1400.00. I blew my top. After going back and forth with local management and Honda Corp. customer service, the dealer is going to repair the vehicle and wants me to pay a "\$200.00" deductible.

This noise did not exist before I took my Odyssey in for the recall. I feel like I should not have to pay any money to repair this problem because this was not a problem previously. It became a problem when the local dealer handled the recall.

What am I to do?

The question is



Replies to this message:

- [mikezinsat \(Feb 22, 2012 7:27 pm\)](#)
- [odv6 \(Oct 08, 2012 8:34 pm\)](#)

#75 of 83 Re: Wobbly Steering [chekraze] by [jhs24](#)

Jan 12, 2012 (5:08 pm)

Replying to: [chekraze \(Nov 10, 2011 5:57 am\)](#)

Perhaps a loose strut bearing or out of round rim or tire. Rotate the tires to see if the wobble moves. Could also be a wheel bearing or loose rack/tie rod.

If it's more of a pull than a wobble then you've got an entirely different problem.



#76 of 83 Get it done before 100K miles by [ingrbrdman](#)

Feb 14, 2012 (2:26 pm)

My 2005 Odyssey is at 99,470 miles today and I just got the fix for the ~~power steering pump~~ this morning. They said I'm lucky because Honda is only allowing the warranty extension for this up till 100K miles. So another 530 miles and I would have been screwed. It is like driving a new van now. The stupid thing has been difficult to turn for the last three years, so this is a huge difference!



#77 of 83 Re: Honda Dealer [boyosan] by [mikezinsat](#)

Feb 22, 2012 (7:27 pm)

Replying to: [boyosan \(Jan 12, 2012 2:39 pm\)](#)

Hello boyosan,

May I ask what did you do please? Just found out today that my situation is very similar - i.e. power

steering pump being replaced, and then they tell me, oh yeah by the way you have a leak in the rack and pinion and that'll be \$1450 to replace!

- mz -



#78 of 83 Honda Seriously Shaking When Braking by [swest2004](#)

Feb 23, 2012 (10:54 am)

I took out 2007 Honda Odyssey into Honda because when my wife brakes the car, the brake pedal goes WAY down and the van shakes like nuts. It is unsafe. We are at 76k miles and have consistently serviced the car.

I get an analysis for repairs of \$2500 and leaks galore!! I am not sure if it is the same issue that people are bringing up but would love help.

They are saying that it needs a \$1430 Rack Pinion repair for a leak, right axle seal leak repair, left rear shock leak, and resurface and brake pads even though at 60%.

I mean for a top-notch vehicle, isn't this nuts to have at only 76k miles???

I have never had a car that needed this much repair under 100k! Also I am getting conflicting info on machining the rotors versus replacing them. This just seems crazy. Anyone else having these issues and is there anything else I need to look into??

The repair guy said that the Odyssey is known for pinion rack and this just seems nuts! Any advise is welcome please!



Replies to this message:

- [clwmike \(May 01, 2012 12:19 pm\)](#)

#79 of 83 Power Steering recall end date? by [jbens](#)

Apr 12, 2012 (7:02 am)

We delayed taking the car into the shop and now find out the recall ended 1 month ago. Anyone else run into this? Is there an actual expiration date? We are at 88K miles.



#80 of 83 Re: Honda Seriously Shaking When Braking [[swest2004](#)] by [clwmike](#)

May 01, 2012 (12:19 pm)

Replying to: [swest2004 \(Feb 23, 2012 10:54 am\)](#)

I bought my Ody back in 2006. Since day one I had already noticed this issue when applying brake at 65 mph or greater. Brought it in and they said they could not find anything. I've heard some people just replaced the front rotors and that fixed it. I have not tried this yet.



#81 of 83 Re: Honda Dealer [boyosan] by [ody6](#)

Oct 08, 2012 (8:34 pm)

Replying to: [boyosan \(Jan 12, 2012 2:39 pm\)](#)

Sounds like the same issue I'm having with my 06 Odyssey touring. The van only has 68,000 miles and we keep in garaged. Got the power pump replaced under extended warranty last December (2011). After the replacement the steering at low speeds still didn't feel like it was working 100%. Wife started complaining about the whining noise when turning at low speeds. When I took it in for servicing last month the dealer told me I had a major power steering leak in the rack & pinion that would cost \$1400+ to fix. Haven't had it fixed yet. The service rep said they only get around one of these a year. Obviously really disappointed in Honda. This is on top of the negative experience we've had with bad harmonics, droning, and shuddering issues that have had multiple attempted warranty fixes; replacing collapsed engine mount a couple times, redesigned exhaust 'A' pipe, and the recent transmission software upgrade.



#82 of 83 Re: **Wobbly Steering [chekraze]** by [pdacunosjr](#)

Oct 17, 2012 (2:02 pm)

Replying to: [chekraze \(Nov 10, 2011 5:57 am\)](#)

Goodness, I thought I was the only one having the hard steering issue until I found this thread. I have an 08 EXL and had the PS pump replace when it fails to gives power assist, it failed state inspection because of it!

Honda Irving replaced it since its still under 30K warranty, now I'm experiencing a signs of hard to steer during slow parking. Im afraid this will end up losing the power assist again.



Replies to this message:

- [goso1 \(Oct 18, 2012 9:42 am\)](#)

#83 of 83 Re: **Wobbly Steering** by [goso1](#)

Oct 18, 2012 (9:42 am)

Replying to: [pdacunosjr \(Oct 17, 2012 2:02 pm\)](#)

Hi, here is the prob that we had with our 08 Ody Touring with non pax tires. The steering wheel would vibrate back/forth 1-2 degrees around 70mph, then after a rotation of the tires, at speeds around 40mph. After much investigation, the dealer determined that it was the original Michelins LX4 out of round or with slipped belts (35K miles on the tires). So new tires have solved it, went with Michelin MXV4, which were better rated on tirerack.

Customer					
VIN	Model	ODYSSEY	Year	2006	
Door	5	Grade	EX		
Area	KA	Mfg	USA	Trans	5AT
Clr Label				Ext Color	
Pricing	MATRIX				
Section	CHASSIS				
Illustration	P.S. GEAR BOX				

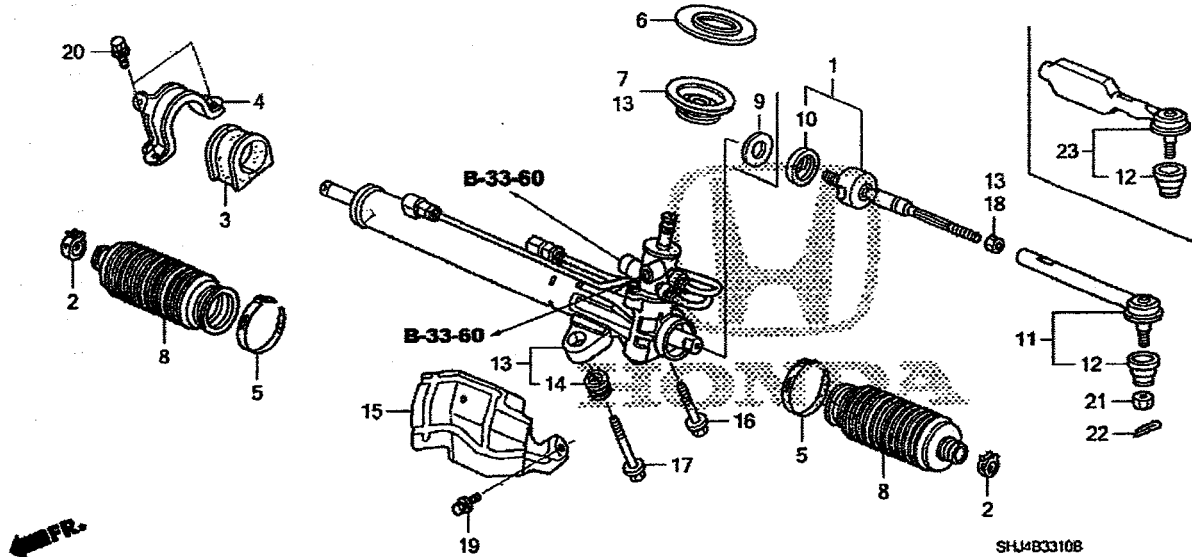

Ref.	Part Number	Part Description	Qty	MATRIX
001	53010-SHJ-A02	JOINT SET, BALL (INNER)	002	\$37.82
002	53434-S87-A01	CLIP	002	\$3.88
003	53436-SHJ-A02	RUBBER, MOUNTING	001	\$6.91
004	53438-SHJ-A00	BRACKET B, STEERING RACK	001	\$8.30
005	53449-SHJ-A02	CLAMP, BELLOWS	002	\$3.47
006	53501-SHJ-A00	GROMMET A, STEERING	001	\$11.72
007	53502-SHJ-A00	GROMMET B, STEERING	001	\$3.95
008	53534-SHJ-A02	BELLOWS	002	\$15.12
009	53535-S0X-A01	SPACER	002	\$11.80
010	53536-S0X-A01	WASHER, TAB	002	\$4.48
011	53540-SHJ-A01	END, TIE ROD	002	\$54.07
012	53546-S3V-A02	BOOT, TIE ROD END	002	\$6.25
013	53601-SHJ-A52	RACK, POWER STEERING	001	\$725.33
014	53685-SHJ-A02	BUSH, MOUNTING	002	\$8.74
015	53692-SHJ-A00	PLATE, POWER STEERING HEAT BAFFLE (LH)	001	\$4.13
016	90107-SHJ-A00	BOLT, GEAR BOX MOUNTING (12X65)	001	\$2.39
017	90108-SHJ-A00	BOLT, GEAR BOX MOUNTING (12X95)	001	\$2.97
018	91411-S87-A01	NUT, HEX. (14MM)	002	\$3.95
019	93404-06014-05	BOLT-WASHER (6X14)	002	\$1.18
020	93402-10020-08	BOLT-WASHER (10X20)	002	\$0.63
020	93412-10020-08	BOLT-WASHER (10X20)	002	\$0.63
021	94030-12280	NUT, HEX. (12MM)	002	\$1.10
022	94201-30220	PIN, SPLIT (3.0X22)	002	\$0.30

[Redacted]
Charlotte, NC - [Redacted]

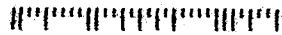

06503

To

National Highway Traffic Administration
1200 New Jersey Ave, SE
Washington, DC - 20590
Auto Safety Hotline (888) 327-4236

