

INFORMATION Redacted PURSUANT TO THE FREEDOM OF
INFORMATION ACT (FOIA), 5 U.S.C. 552(B)(6)

AUG - 8 2012

Houston, TX

July 30, 2012

Mr. Barack Obama
President, United States of America
The White House
1600 Pennsylvania Ave. NW
Washington, DC 20500

Ray LaHood, Secretary
U.S. Department of Transportation
1200 New Jersey Ave. SE
Washington, DC 20590

Mary Mack, Chairwoman
House Energy & Commerce Committee
Commerce, Manufacturing & Trade
2125 Rayburn House Office Bldg.
Washington, DC 20515

Leslie Moonves, Chairman
ABC
500 S. Buena Vista St.
Burbank, California 91505

Ken Lautz, President
CNN
105366 One CNN Center
Atlanta, GA 30348

Steve Burke, CEO
NBC
30 Rockefeller Plaza # 1802
New York City, NY 10020

Ethan A. Huff, Reporter
Chicago Tribune
435 N. Michigan Ave.
Chicago, IL 60611

David Strickland, Administrator
NHTSA
1200 New Jersey Ave. SE West Bldg.
Washington, DC 20590

G.K. Butterfield, Committee Member
House Energy & Commerce Committee
Commerce, Manufacturing & Trade
2125 Rayburn House Office Bldg.
Washington, DC 20515

Bob Iger, Chairman
CBS
51 W. 52nd St.
New York, NY 10019-6188

Peter Rice, Chairman
FOX
1211 Avenue of the Americas
New York City, NY 10020

Chris Woodyard, Writer
USA Today
7950 Jones Brance Dr.
McLean, VA 22108

Michael Tortorello, Reporter
The New York Times
229 W. 43rd St.
New York, NY 10036

NM
081012
TGW

David Lazarus, Reporter
Los Angeles Times
202 W. 1st St.
Los Angeles, CA 90012

Tom Fox, Reporter
Washington Post
1150 15th St. N.W.
Washington, DC 20071

RE: DEMAND NHTSA MANDATORY RECALL ON GENERAL MOTORS COMPANY' 2007 -2008 CHEVROLET IMPALA' DEFECTIVE REAR WHEEL SPINDLE RODS

Dear President Obama, Secretary LaHood, Administrator Strickland, Congresswoman Mack, Congressman Butterfield, Chairman, Moonves, Chairman, Iger, President Lautz, Chairman Rice, CEO Burke, Reporter Woodyard, Reporter Huff, Reporter Tortorello, Reporter Fox and Reporter Lazarus:

Mr. President I am respectfully requesting your consideration and approval to direct Ray La Hood, Secretary of Transportation and David Strickland, NHTSA administrator to issues an urgent investigation and mandatory safety recall for the above mentioned company and vehicles as 400,000 civilian vehicles have the identical problem as the police packaged on. As required by NHTSA a notification shall be given to the government in a timely manner of suspected safety defects however, this has not been given. In 2008 GMC issues its bulletin # 08032 proclaiming the discovery of rear wheel spindle rods defect. NHTSA should have immediately told GM to recall civilian car along with police packaged vehicles. GM decision not to halt the sale of new and pre-owned civilian cars and not issue a recall notice was legally and morally the wrong thing to do.

Also, I am respectfully requesting consideration and approval for all listed executives, reporters to stand and take an active role into this investigation by committing your company's resources to aid in this national safety endeavor. Combined corporate and consumer safety outrage and bipartisan effort would be an unprecedented approach considering congressional approval saved that company in 2009. Confirmation of these unlawful acts should be directed to the U.S. AGO to consider civil/criminal action against GM for this safety-related defect and not notifying and warning the feds or 400,000 consumers, which are violations under the Safety Act. If however, the federal government feels it would be inappropriate to pursue legal action then grant me permission to bring legal action on behalf of the government.

The estimated 400,000 GM Impala customers are from every state and we all purchased new or pre-owned vehicles and have experienced damaged vehicles, wrecks, injuries, maybe death and financial burden because of the defective spindle rods.

In June 2009 General Motors Corporation filed Chapter 11 Bankruptcy protection and with the \$49.5 billion American Tax Payers funding bailout emerged from bankruptcy into the current General Motors Company and would not have been held accountable for these vehicles liability claims. However, at the demands of several states Attorney General GM agrees to accept future product liability claims. Specifically, GM states that GM will:

“ expressly assume all products liability claims arising from accidents or other discrete incidents arising from the operation of GM vehicles occurring subsequent to (the emergence of New GM), regardless of when the product was purchased, ”. Of course GM is not doing so and this possibly could be a contempt of court issue.

June, 2008 General Motors Corporation issued a Program Bulletin No. 08032 regarding: *“Uneven Police Car Rear Tire Wear-Replace Rear Wheel Spindle Rods” 2007-2008 Chevrolet Impala (Equipped with Police Package (RPO 9C1/9C3)). Attached for review and investigation is GMC Bulletin.*

First, GMC at the time of its Bulletin No: 08032 knew that all Impala listed within the recalled VIN breakpoint were equipped with the identical frame, chassis, suspension, spindle rods as the police packaged listed for recall. GM Dealers parts department has the identical part numbers for civilian vehicles' spindle rods as the identical part numbers listed on the recall bulletin for police vehicles. According to GM spokesman Alan Adler 23,800 of those cars became police models. GM knew that the majority of the 423,000 vehicles listed on the recall bulletin identified by VIN breakpoint were purchased by civilians and its product was unreasonably dangerous and civilian were reasonably anticipated consumers. *I have attached photos of the rear wheel tire wear and danger which GM admits the defective spindle rods cause for your review and inspection.*

Secondly, GM may have breached it' express warranty by improperly concealing these defects to civilians and NHTSA; which is a violation of the *Federal Motor Vehicle Safety Standards and Regulations Act., Title 49 of the United States Code, Chapter 301, Motor Vehicle Safety. Also, by fraud and non concealment are in violation Vehicle Safety Compliance including Part 557, Part 573 and Part 577.*

During your investigation ask what was the motive for GMC to volunteer a recall for police packaged Impala's. Simply an offensive move since the government bail out was pending, and the appearance of defective police vehicles would not be political correct to be owned by the federal government and have safety defected police vehicles on the

streets. General Motors Company emerged liabilities free from the safety liability and financial burden of tax payers their unsuspecting valued customers/consumers.

July, 2012 I filed an on-line complaint with (ODI Number 10466916) NHTSA regarding my safety related vehicle crash and sustained injury occurring on October 30, 2010. I also reviewed about 175 identical safety complaints. *Attached for review and investigation safercar.gov, filed complaints.* NHTSA and General Motors Company may argue that 175 incidents is a small ratio for 400,000 vehicles manufactured. I'm guessing when NHTSA open this can of worms the consumers complaints will increase to the thousands. Is it believable that GMC recalled over 4230,000 in bulletin No. 08032 all vehicles identify by VIN breakpoint and only about 175 have been report on NHTSA complaint hotline? Most consumers do not and will not report if the manufacture or government has not given notice or warnings of the dangerous defect.

Personal Incident:

I purchased and paid cash for my 2007 Chevy. Impala in 2009. While traveling down FM 247 South in Huntsville, TX. @ posted speed of 60 mph around 1:10pm, my rear tires involuntarily Swerved causing my vehicle to steer and crash off road. Crashing in /on grassy and wooden Shoulder of road. My vehicle ran over and on top of debris, trees, and stumps before being able to Control and stop the vehicle. I sustained minor vehicle damage, mostly under body and bodily Injuries requiring emergency medical treatment and surgery.

Mr. President and other officials please know that I am aware that the federal government does not bring individual legal action and I am not requesting such action. However, it is our government' duty and citizen rights to be protected from this negligence, fraud and harm; and not for the sake of corporate profits. While I have not filed a civil action for my harm, I am demanding a settlement from GM.

However, like all 400,000 other consumers they are putting profit over consumer welfare and satisfaction. The federal government knows quite well the expense of legal action against a corporate giant like GM and most legal firms do not want to pursue this type of case unless serious injury or death occurs. I am aware of a Class Action Complaint filed in the U.S. District Court, Eastern District of Michigan in 2011. However, this want stop a corporate giant like GM from business as usually and manufacturing defective products and failing its duty of consumer safety. Now it appears GM will try to hide behind the "old GM" bankruptcy claim it does not have to pay money to us consumers.

Today since it is known that civilian Impalas within the recalled VIN breakpoint has identical defective, these dangerous vehicles are being pushed off in the communities of *the poor and youth consumers. All of these 400,000 dangerous and unrepaired vehicles are continuing to being sold and driven without repairs or without manufacture or government warnings. Therefore consumers' safety will continue to be at risk.*

I believe our concerns are equal to the Toyota safety defect and there was a national outcry for consumer justice and vehicle safety. **NOW** this should be treated with the same effort and resolve. All of the Impalas are assembled in Canada, should this send up a red flag.

Again, I am respectfully requesting that NHTSA issue a mandatory recall and demand justice for consumers. We now need a bailout and the Profitable General Motors Company owes and has a duty to take responsibility for it' harmful defective product. I am willing to testify at hears, lead plaintiff position, news interviews or whatever is deem appropriate to secure justice on behalf of all current and future consumers of the General Motors' defective 2007 – 2008 Chevrolet Impalas (civilian packaged).

I would encourage CNN, CBS, NBC, FOX, ABC, USA Today and Congressmen to help by demanding NHTSA recall and to promoting this public safety announcement by utilizing your resources to give notification to 400,000 + GM customers and for them to demand consumer justice. I would also encourage help at starting a petition campaign in the media or online

Thank you all in advance for your consideration and if appropriate efforts at securing a 400,000 citizen bail out and holding General Motors Company accountable to stand by it' duty and chapter 11 bankruptcy agreement to assume all products liability claims.

CC:

Mr. Daniel Akerson, Chairman
General Motors Company
100 Renaissance Center
Detroit, Michigan 48243-1312

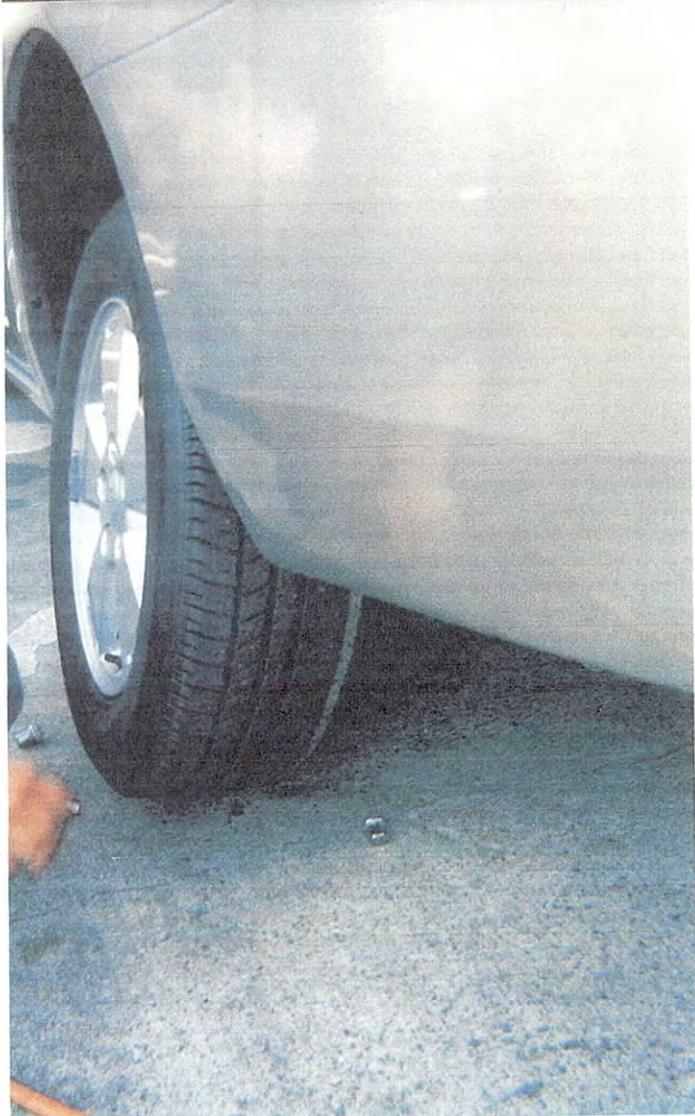



Program Bulletin



CUSTOMER SATISFACTION PROGRAM

SUBJECT: Uneven Police Car Rear Tire Wear – Replace Rear Wheel Spindle Rods

MODELS: 2007-2008 Chevrolet Impala
Equipped with Police Package (RPO 9C1/9C3)

This bulletin is being released with individual part numbers for the rear wheel spindle rods. In the near future, GM will release a single part number spindle rod kit containing necessary parts. When the rod kits are available, the bulletin will be revised to include the new part number. In the meantime, please use the parts listed in the bulletin until the kits are available.

CONDITION

On **certain** 2007-2008 model year Chevrolet Impala vehicles equipped with a police package (RPO 9C1/9C3), the rear wheel spindle rods may cause rear wheel misalignment, resulting in lower tread depth on the inboard side of the rear tire.

CORRECTION

Dealers are to replace the rear wheel spindle rods, align the rear wheels, and if necessary, replace the rear tires (only) that exhibit lower tread depth on the inboard side. If the tires have already been replaced due to this condition, the customer may request reimbursement for the replacement tires until July 31, 2009.

VEHICLES INVOLVED

Involved are **certain** 2007-2008 model year Chevrolet Impala vehicles equipped with a police package (RPO 9C1/9C3) and built within these VIN breakpoints:

Year	Division	Model	From	Through
2007	Chevrolet	Impala	79129274	79419427
2008	Chevrolet	Impala	81174923	81237574
			89100019	89283506

Important: Dealers are to confirm vehicle eligibility prior to beginning repairs by using the General Motors Inquiry System (GMVIS). Not all vehicles within the above breakpoints may be involved.

For dealers with involved vehicles, a listing with involved vehicles containing the complete vehicle identification number, customer name, and address information has been prepared and will be provided through the applicable system listed below. Dealers will not have a report available if they have no involved vehicles currently assigned.

- US dealers - GM DealerWorld Recall Information
- Canadian dealers - GMInfoNet Recall Reports
- Export dealers - sent directly to dealers

The listing may contain customer names and addresses obtained from Motor Vehicle Registration Records. The use of such motor vehicle registration data for any purpose other than follow-up necessary to complete this program is a violation of law in several states/provinces/countries. Accordingly, you are urged to limit the use of this report to the follow-up necessary to complete this program.

PARTS INFORMATION

Parts required to complete this program are to be obtained from General Motors Service and Parts Operations (GMSPO). Please refer to your "involved vehicles listing" before ordering parts. Normal orders should be placed on a DRO = Daily Replenishment Order. In an emergency situation, parts should be ordered on a CSO = Customer Special Order.

Part Number	Description	Quantity/Vehicle
10329689*	Rod,RR Whl Spdl (RR)	2
10329691*	Rod,RR Whl Spdl (FRT)	2

* In the near future, GM will release a single part number spindle rod kit containing necessary parts. When the rod kits are available, the bulletin will be revised to include the new part number. In the meantime, please use the parts listed in the bulletin until the kits are available

SERVICE PROCEDURE

1. Raise and support the vehicle.
2. Remove the rear tires and wheels.
3. Remove the exhaust pipe/muffler assembly.
4. Remove the wiring harness clips from the spindle arms and from the connector at the body.

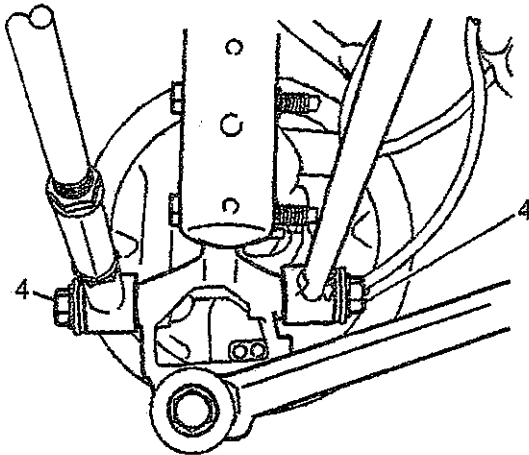

2129076

5. Remove the rear wheel spindle rod bolts (4) and nuts from the knuckles (both sides).
6. Remove the stabilizer shaft from the rear suspension support.
7. Support the rear suspension support with jack stands and remove the mounting bolts.
8. Lower the rear suspension support in order to gain access to the rear wheel spindle rod to support bolts.

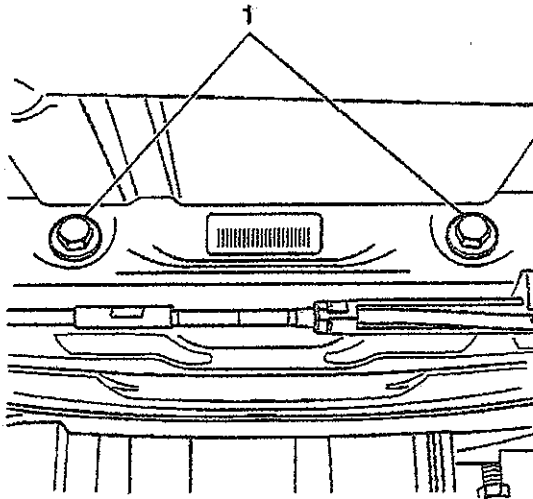

614974

9. Remove the four rear wheels spindle rod bolts (1) and nuts from the rear suspension support.
10. Remove the rear wheel spindle rods from the vehicle.
11. Install the new rear wheel spindle rods to the vehicle.

12. Install the four rear wheel spindle rod bolts and nuts to the rear suspension support.

Tighten

Tighten the bolts to 135 N·m (100 lb ft).

13. Raise the rear suspension support into place.
14. Install the rear suspension support mounting bolts and remove the jack stands.

Tighten

Tighten the bolts to 110 N·m (85 lb ft).

15. Install the stabilizer shaft to the rear suspension support.
16. Install the rear wheel spindle rod bolts and nuts to the knuckles (both sides).

Tighten

Tighten the nuts to 150 N·m (110 lb ft).

17. Install the wiring harness clips to the spindle arms and to the connector at the body.
18. Install the exhaust pipe/muffler assembly.
19. Inspect the rear tires for uneven wear. Inspect the tread depth at the inboard and outboard tread blocks, and if there is more than 2.4 mm (3/32 in) difference in wear, install two new tires. If the customer has replaced the original Pirelli tires with four lower speed rated tires, install the same brand or comparable tire that was removed.
20. Install the rear tires and wheels.
21. Lower the vehicle.
22. Adjust the wheel toe angle.

CUSTOMER REIMBURSEMENT - For GM US

All customer requests for reimbursement for previous repairs for the condition will be handled by the Customer Assistance Center, not by dealers.

A General Motors Customer Reimbursement Procedure and Claim Form is included with the customer letter.

IMPORTANT: (For GM Only) Refer to the GM Service Policies and Procedures Manual, section 6.1.12, for specific procedures regarding customer reimbursement and the form.

CUSTOMER REIMBURSEMENT - For Canada and Export

Customer requests for reimbursement for previous repairs for the condition are to be submitted to the dealer by July 31, 2009.

All reasonable customer paid receipts should be considered for reimbursement. The amount to be reimbursed will be limited to the amount the repair would have cost if completed by an authorized General Motors dealer.

When a customer requests reimbursement, they must provide the following:

- Proof of ownership at time of repair.
- Original paid receipt confirming the amount of repair expense(s) that were not reimbursed, a description of the repair, and the person or entity performing the repair.

Claims for customer reimbursement on previously paid repairs are to be submitted as required by WINS.

IMPORTANT: Refer to the GM Service Policies and Procedures Manual, section 6.1.12, for specific procedures regarding customer reimbursement verification.

CLAIM INFORMATION

Submit a Product Claim with the information indicated below:

Repair Performed	Part Count	Part No.	Parts Allow	CC-FC	Labor Op	Labor Hours	Net Item
Replace Four Rear Wheel Spindle Rods (inc. alignment)	4	---	*	MA-96	V1828	1.9	N/A
Add: Mount and Balance Two Rear Tires	2					0.4	
Customer Reimbursement (Canadian & Export Dealers/US CAC)				MA-96	V1829	0.2	**

* The "Parts Allowance" should be the sum total of the current GMSPD Dealer net price plus applicable Mark-Up or Landed Cost Mark-Up (for Export) for the four rear wheel spindle rods needed to complete the repair, and if required, two rear tires.

** The amount identified in the "Net Item" column should represent the dollar amount reimbursed to the customer and will expire July 31, 2009

Refer to the General Motors WINS Claims Processing Manual for details on Product Recall Claim Submission.

CUSTOMER NOTIFICATION – For US and Canada

General Motors will notify customers of this program on their vehicle (see copy of customer letter included with this bulletin).

CUSTOMER NOTIFICATION – For Export

Letters will be sent to known owners of record located within areas covered by the US National Traffic and Motor Vehicle Safety Act. For owners outside these areas, dealers should notify customers using the attached sample letter.

DEALER PROGRAM RESPONSIBILITY

All unsold new vehicles in dealers' possession and subject to this program must be held and inspected/repared per the service procedure of this program bulletin before customers take possession of these vehicles.

Dealers are to service all vehicles subject to this program at no charge to customers, regardless of mileage, age of vehicle, or ownership, from this time forward.

Customers who have recently purchased vehicles sold from your vehicle inventory, and for which there is no customer information indicated on the dealer listing, are to be contacted by the dealer. Arrangements are to be made to make the required correction according to the instructions contained in this bulletin. A copy of the customer letter is provided in this bulletin for your use in contacting customers. Program follow-up cards should not be used for this purpose, since the customer may not as yet have received the notification letter.

In summary, whenever a vehicle subject to this program enters your vehicle inventory, or is in your dealership for service in the future, you must take the steps necessary to be sure the program correction has been made before selling or releasing the vehicle.

GM bulletins are intended for use by professional technicians, NOT a "do-it-yourselfer". They are written to inform these technicians of conditions that may occur on some vehicles, or to provide information that could assist in the proper service of a vehicle. Properly trained technicians have the tools, equipment, safety instructions, and know-how to do a job properly and safely. If a condition is described, **DO NOT** assume that the bulletin applies to your vehicle, or that your vehicle will have that condition. See your dealer/retailer for information on whether your vehicle may benefit from the information.



We Support
Voluntary
Technician
Certification

June 2008

Dear General Motors Customer:

We have learned that a condition exists on your 2007 or 2008 model year Chevrolet Impala police vehicle that may cause rear wheel misalignment, resulting in lower tread depth on the inboard side of the rear tires.

Your satisfaction with your 2007 or 2008 model year Chevrolet Impala police vehicle is very important to us, so we are announcing a program to prevent this condition or, if it has occurred, to fix it.

What We Will Do: Your Chevrolet dealer will replace the rear wheel spindle rods, align the rear wheels, and if necessary, replace the rear tires. If you have replaced the original Pirelli tires with four lower speed rated tires, your dealer will install the same brand or comparable tire that you installed. This service will be performed for you at **no charge**.

What You Should Do: If you have not inspected the rear tires for adequate depth across all of the tread in the last month, you should do so **now** or contact your Chevrolet dealer for an immediate inspection. See *When It Is Time for New Tires* in your owner manual. Driving with worn tires is dangerous.

To limit any possible inconvenience, we recommend that you contact your dealer as soon as possible to schedule an appointment for this repair. By scheduling an appointment, your dealer can ensure that the necessary parts will be available on your scheduled appointment date.

Customer Reply Form: The enclosed customer reply form identifies your vehicle. Presentation of this form to your dealer will assist in making the necessary correction in the shortest possible time. If you no longer own this vehicle, please let us know by completing the form and mailing it back to us.

Reimbursement: The enclosed form explains what reimbursement is available and how to request reimbursement if you have paid to have the rear tires replaced because of this condition. Your request for reimbursement, including the information and documents mentioned on the enclosed form, must be received by GM by July 31, 2009.

If you have any questions or need any assistance to better understand related repairs, please contact your dealer. If you have questions related to a potential reimbursement, please contact the appropriate Customer Assistance Center at the number listed below.

Division	Number	Text Telephones (TTY)
Chevrolet	1-800-630-2438	1-800-833-2438
Guam	1-671-648-8450	
Puerto Rico -- English	1-800-496-9992	
Puerto Rico -- Español	1-800-496-9993	
Virgin Islands	1-800-496-9994	

We sincerely regret any inconvenience or concern that this situation may cause you. We want you to know that we will do our best, throughout your ownership experience, to ensure that your Chevrolet Impala provides you many miles of enjoyable driving.

Scott Lawson
General Director,
Customer and Relationship Services

Enclosure
08032

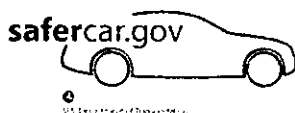

Complaints - Search Results

33 Record(s) Displayed.

Report Date : July 22, 2012 at 05:16 PM
 Search Type : VEHICLE
 Year : 2007
 Make : CHEVROLET
 Model : IMPALA

Make : CHEVROLET **Model :** IMPALA **Year :** 2007
Manufacturer : GENERAL MOTORS LLC
Crash : No **Fire :** No **Number of Injuries :** 0
ODI ID Number : 10449019 **Number of Deaths :** 0
Date of Failure : June 16, 2008
VIN : 2G1WU58R479...
Component: TIRES

Summary:

I NOTICED THINGS ABOUT MY CAR BUT IGNORED THEM BECAUSE I THOUGHT, THIS IS A BRAND NEW CAR AND IT SHOULDN'T HAVE ANY ISSUES. FROM THE VERY BEGINNING I WOULD NOTICE THAT MY CAR WOULD SLIDE A LOT WHEN THERE WAS SNOW/ICE/RAIN ON THE GROUND. AS IF IT WASN'T SITTING ON THE GROUND PROPERLY. I WOULD LOOK AT IT FROM THE REAR AT A DISTANCE AND IT ALWAYS SEEMED TO SLANT/DROOP AT AN ANGLE. ABOUT A YEAR AND HALF OF OWNERSHIP WHILE GETTING MY OIL CHANGED A SERVICE TECH FROM AN AUTHORIZED CHEVROLET DEALER INFORMED ME THAT I HAD EXCESSIVE TIRE WEAR AND STATED THAT I NEEDED ALL NEW TIRES. NOTE HE NEVER STATED THAT I NEEDED A WHEEL ALIGNMENT OR THAT THERE WAS A POSSIBLE RECALL NOTICE THAT WE COULD FIX WHILE YOUR CAR IS STILL UNDER. HE JUST WANTED TO SELL ME TIRES. FROM DOING MY RESEARCH IT LOOKS LIKE I AM NOT ALONE WITH THE ISSUE OF EXCESSIVE TIRE WEAR. LOOKS LIKE GM IS ALSO AWARE OF THIS ISSUE. THERE IS A GM BULLETIN 08032 BUT GM ONLY STATES THAT GOVERNMENT CARS ARE AFFECTED. I KNOW OF SEVERAL PEOPLE THAT WORK ON GM ASSEMBLY LINES AND THEY WILL STATE THAT THERE IS NO DIFFERENCE, SO WHY HAS THERE NOT BEEN A RECALL ON THIS ISSUE. THIS IS VERY DANGEROUS FOR GM TO KNOWINGLY KNOW THAT SOMETHING IS NOT CORRECT ON THESE CARS AND THEY ARE REFUSING TO DO ANYTHING ABOUT IT. HOW MANY LIVES HAVE BEEN LOST OR HAVE TO BE LOST FOR GM TO CALL A RECALL AND FIX THE ISSUE ON THESE CARS. UPDATE 2/22/2012: I HAVE GOTTEN THE "NEEDED" "SPECIAL" WHEEL ALIGNMENT BUT AM STILL CONSTANTLY REPLACING TIRES THAT HAVE BEEN ON MY CAR NOT EVEN A YEAR. WILL NEVER BUY A CHEVY AGAIN. NOT REPUTABLE AND DOING THE RIGHT THING WHICH IS TO CORRECTLY FIX OVER 400,000 CARS. *TR

Make : CHEVROLET **Model :** IMPALA **Year :** 2007
Manufacturer : GENERAL MOTORS LLC
Crash : No **Fire :** No **Number of Injuries :** 0
ODI ID Number : 10442618 **Number of Deaths :** 0
Date of Failure : July 22, 2009
VIN : 2G1WT58K179...
Component: TIRES

Summary:

TIRES BALD AT 33,428 MILES & REPLACED REPLACED ANOTHER TIRE 7/2011 AROUND 52,000 MILES THREE OTHERS ARE WITHIN 1 OR 2 /32 ND OF BEING WORN OUT AGAIN AT 56,056. *TR

Make : CHEVROLET **Model :** IMPALA **Year :** 2007
Manufacturer : GENERAL MOTORS LLC
Crash : No **Fire :** No **Number of Injuries :** 0
ODI ID Number : 10436526 **Number of Deaths :** 0
Date of Failure : November 21, 2011
VIN : 2G1WT58K979...
Component: TIRES

Summary:

MY 2007 CHEVROLET IMPALA WAS RECENTLY IN CHEVROLET SHOP FOR 30,000 MILES MAINTENANCE. I WAS SHOCKED WHEN TOLD I NEEDED TIRES. I AM THE ORIGINAL OWNER AND DRIVE TO AND FROM WORK AND AN OCCASIONAL WEEKEND TRIP. I HAVE MY TIRES ROTATED EVERY 10,000 MILES. WHAT GIVES? *TR

Make : CHEVROLET **Model :** IMPALA **Year :** 2007
Manufacturer : GENERAL MOTORS LLC
Crash : No **Fire :** No **Number of Injuries :** 0
ODI ID Number : 10436493 **Number of Deaths :** 0
Date of Failure: August 12, 2008
VIN : Not Available
Component: TIRES

Summary:

TIRES COMPLETELY WORN AT 23,000 MILES DEALER SAID BECAUSE NOT ROTATED PROPERLY (\$500 FOR NEW TIRE) ROTATED EVERY 7000 MILES THEY FAILED AT 61,209 MILES PUT ON FOUR NEW TIRES (3RD SET ANOTHER \$470) AND ROTATED EVERY 5000 DEALER SAID POOR CHOICE OF TIRES INSTALLED GOODYEAR PREMIUM TIRE NEXT SET WENT IN 20000 MILES WHEEL ALIGNMENT DONE EVERY YEAR NO ADJUSTMENTS NEEDED, LAST SET OF TIRES NOW WORN AT MILEAGE 83,300. I HAVE HAD 15 NEW CARS DURING MY LIFETIME AND NEVER HAVE I ENCOUNTERED THE PREMATURE WEAR I HAVE ON THIS IMPALA. DRIVING ALL HIGHWAY MILES I DO NOT SPEED OR CORNER FAST I ROTATE TIRES CHECK AIR PRESSURE IN ADDITION TO TPMS SYSTEM WHY AM I SEEING TIRE FAILURE ON THREE DIFFERENT BRANDS OF PREMIUM TIRE? *TR

Make : CHEVROLET **Model :** IMPALA **Year :** 2007
Manufacturer : GENERAL MOTORS LLC
Crash : No **Fire :** No **Number of Injuries :** 0
ODI ID Number : 10424655 **Number of Deaths :** 0
Date of Failure: September 6, 2011
VIN : Not Available
Component: TIRES

Summary:

I HAD NUMEROUS PROBLEMS WITH THIS VEHICLE (ALMOST THROUGH MY THIRD SET OF TIRES, OXYGEN SENSOR GOING AT 48,000 MILES, RUST BEGINNING AT 38,000 MILES (CAR WAS TWO YEARS OLD), AND THE BATTERY GOING PREMATURELY). LAST WEEK, I ATTEMPTED TO PUT ON MY REAR DEFOGGER. THE LIGHT CAME ON, BUT MY REAR WINDSHIELD WAS STILL FOGGED UP. THE DEFROSTER ALSO DOES NOT BLOW COLD AIR IF THE CAR IS IN PARK. *TR

Make : CHEVROLET **Model :** IMPALA **Year :** 2007
Manufacturer : GENERAL MOTORS LLC
Crash : No **Fire :** No **Number of Injuries :** 0
ODI ID Number : 10414873 **Number of Deaths :** 0
Date of Failure: July 20, 2011
VIN : 2G1WD58C079...
Component: TIRES

Summary:

WE PURCHASED OUR 2007 IMPALA SS ON 11/17/09 WITH 33,003 MILES ON IT. ON JULY 20, 2011 WHILE DRIVING HOME FROM WORK WITH MY WIFE AND STEPSON ON THE I-94 FREEWAY IN CLINTON TOWNSHIP, MI., THE LEFTSIDE REAR TIRE BLEWOUT. WE NOTICE THAT IT HAD BROKE THE INNER PLASTIC PIECE AND BENT THE MUFFLER TIP AND THERE WAS CLEARLY NO RUBBER LEFT ON THE INSIDE OF THE TIRE ALL YOU SAW WAS WIRES. HAD TO PUT OUR SPARE TIRE ON. TOOK THE CAR INTO THE TIRE SHOP ON JULY 22, 2011 TO HAVE THAT TIRE REPLACED. SERVICE GUY SAID THERE WAS NO RUBBER LEFT ON THE INSIDE OF THE LEFT TIRE IN THE REAR, AND THE WIRES WERE CLEARLY VISIBLE AND SHOWED US THEM, WHICH WE HAD NOTICED WHEN THIS OCCURRED. HE ALSO STATED THAT ON THE REAR RIGHTSIDE THE WIRES WERE SHOWING TOO. WE HAD HIM REPLACE ALL 4 TIRES ON THE VEHICLE. HE ALSO STATED THAT WE HAD BEEN THE 4TH IMPALA THEY HAD REPLACED TIRES ON IN THE PAST WEEK. WHILE ON THE LIFT WE NOTICED THAT THE BACK TIRES WERE SLIGHTLY LEANING OUT, LIKE (L) LEFT SIDE AND (R) RIGHT SIDE, I TOLD HIM THAT I WANT THE TIRES BACK AND HE GAVE THEM TO ME. WE TOOK THEM HOME AND TOOK PICKS OF THEM AND THE BACK OF OUR CAR TO SHOW HOW THE TIRES WERE STILL LEANING OUT, AND ALSO TOOK PICTURES OF WHERE THE PLASTIC HAD BEEN BROKE IN THE WHEEL WELL. THIS HAS HAPPENED IN LESS THAN 20,000 MILE SINCE WE PURCHASED THE VEHICLE. I WENT TO THE DEALERSHIP THAT WE PURCHASED THE VEHICLE FROM AND TOLD THE SERVICE GUY WHAT HAD HAPPENEO, HE STATED THAT THERE WAS NO RECALL AS OF YET ON THIS PROBLEM BUT THAT OTHER PEOPLE HAD CAME IN WITH THE SAME COMPLAINTS, THAT I SHOULD GET AHOLD OF GM AND SEE WHAT THEY SAY. HE TOLD ME THAT HE WAS AWARE OF THE POLICE VEHICLE THAT HAD BEEN RECALLED BUT AS OF YET KNEW NOTHING ABOUT ALL OTHERS. HE STATED THAT HE WISHED HE COULD DO SOMETHING FOR US BUT THERE WAS NOTHING HE COULD DO. WHEN IS GM GONNA DO SOMETHING ABOUT THIS? *TR

Make : CHEVROLET **Model :** IMPALA **Year :** 2007
Manufacturer : GENERAL MOTORS LLC
Crash : No **Fire :** No **Number of Injuries :** 0
ODI ID Number : 10411514 **Number of Deaths :** 0

Date of Failure: May 15, 2010

VIN : 2G1WT58K679...

Component: TIRES

Summary:

MY 2007 IMPALA TIRES WORE OUT PREMATURELY. I NOTICED THE TIRES STARTING TO WEAR OUT ON THE INSIDE AT ABOUT 6,000 MILES AND HAD THE TIRES ALIGNED AND ROTATED. THE TIRES CONTINUED TO WEAR OUT ON THE INSIDE. I BROUGHT THIS TO THE ATTENTION OF LUCK CHEVROLET AT ABOUT 32,000 MILES AND THEY SAID GM WOULD NOT COVER THIS REPAIR UNDER THE WARRANTY. HOWEVER THEY DID SAY THERE WAS A PROBLEM AND A KIT COULD BE INSTALLED TO CORRECT. I REPLACED THE TIRES AND HAD GOODYEAR INSTALL THE CAMBER KIT TO CORRECT THE PROBLEM. I SPENT \$800 FOR NEW TIRES WHEEL ALIGNMENT AND THE CAMBER KIT. *TR

Make : CHEVROLET

Model : IMPALA

Year : 2007

Manufacturer : GENERAL MOTORS LLC

Crash : No

Fire : No

Number of Injuries: 0

ODI ID Number : 10410784

Number of Deaths: 0

Date of Failure: July 3, 2011

VIN : 2G1WT58K479...

Component: TIRES

Summary:

TIRES WEAR UNEVENLY AND PREMATURELY WITH POSSIBILITY OF UNEXPECTED BLOW-OUT AT HIGHWAY SPEEDS. *TR

Make : CHEVROLET

Model : IMPALA

Year : 2007

Manufacturer : GENERAL MOTORS LLC

Crash : No

Fire : No

Number of Injuries: 0

ODI ID Number : 10410765

Number of Deaths: 0

Date of Failure: February 1, 2010

VIN : Not Available

Component: TIRES

Summary:

TL* THE CONTACT OWNS A 2007 CHEVROLET IMPALA. THE CONTACT STATED THAT THE REAR PASSENGER SIDE TIRE CONTINUOUSLY WORE PREMATURELY. THE CONTACT HAD SEVERAL ALIGNMENTS PERFORMED ON THE VEHICLE WITHIN TWO YEARS. IN ADDITION, WHEN DRIVING IN SNOWY WEATHER, THE CONTACT WAS UNABLE TO TRAVEL ABOVE 35 MPH OR THE REAR END OF THE VEHICLE WOULD FISH TAIL. NEITHER THE DEALER NOR THE MANUFACTURER WAS NOTIFIED OF THE FAILURE. THE CURRENT MILEAGE WAS 109,000 AND THE APPROXIMATE FAILURE MILEAGE WAS 35,000. THE VIN WAS UNAVAILABLE.

Make : CHEVROLET

Model : IMPALA

Year : 2007

Manufacturer : GENERAL MOTORS LLC

Crash : No

Fire : No

Number of Injuries: 0

ODI ID Number : 10410601

Number of Deaths: 0

Date of Failure: June 1, 2008

VIN : 2G1WC58R379...

Component: TIRES

Summary:

VEHICLE PERFORMED POORLY OVER 35 MPH ON HIGHWAY WITH THE REAR OF THE VEHICLE SWAYING EXCESSIVELY. THE TIRES ON THE BACK OF THE VEHICLE WORE PREMATURELY. I HAD A DEALERSHIP LOOK AT THE VEHICLE AND THERE WAS NO DAMAGE TO VEHICLE SUSPENSION. I HAD TO HAVE AN ALIGNMENT AND NEW TIRES PUT ON THE VEHICLE. I COMPLAINED TO GENERAL MOTORS BUT THEY WERE ONLY REIMBURSING POLICE VEHICLES FOR PREMATURE REAR TIRE WEAR. *KB

Make : CHEVROLET

Model : IMPALA

Year : 2007

Manufacturer : GENERAL MOTORS LLC

Crash : No

Fire : No

Number of Injuries: 0

ODI ID Number : 10392785

Number of Deaths: 0

Date of Failure: March 22, 2011

VIN : 2G1WT58K579...

Component: TIRES

Summary:

CAR PURCHASED USED WITH NEW TIRES IN MARCH OF 2009. IN APRIL OF 2010 REAR TIRES HAD

SEVERE WEAR ON INSIDE TREAD THAT CAUSED BELTS TO SHOW. FOUR NEW TIRES WERE INSTALLED AND A FOUR WHEEL ALIGNMENT WAS DONE. 11 MONTHS LATER REAR TIRES SHOWED THE SAME WEAR, INSIDE OF TIRE. WAS TOLD THERE WAS A SAFETY BULLETIN FROM GM BUT DIDN'T COVER MY CAR SINCE IT WAS NOT A POLICE VERSION. WAS TOLD BY DEALERSHIP THAT GM KNOWS ABOUT THIS PROBLEM AND HAS COME OUT WITH A CAMBER KIT TO FIX PROBLEM BUT I HAD TO PURCHASE IT AND HAVE IT INSTALLED. WHEN ASKED WHY IF IT WAS A MANUFACTURE DEFECT WITH THE VEHICLE CAUSING PREMATURE TIRE WEAR I WAS HAVING TO PAY FOR IT WAS BRUSHED OFF. CALLED CHEVROLET AND FILED A FORMAL COMPLAINT REGARDING THE MATTER AND WAS TOLD THAT IT WAS A MAINTENANCE ISSUE AND I WOULD HAVE TO PAY FOR THE REPAIR. CHEVY KNOWS THAT THERE IS A PROBLEM WITH THIS VEHICLE AND REFUSES TO TAKE RESPONSIBILITY TO REPAIR/FIX PROBLEM AND IS INSTEAD PUSHING THIS OFF ON THE CONSUMER. EXCESSIVE TIRE WEAR IS A SAFETY PROBLEM AND I GUESS PEOPLE HAVE TO DIE FOR ACTION TO BE TAKEN. *TR

Make : CHEVROLET **Model :** IMPALA **Year :** 2007
Manufacturer : GENERAL MOTORS LLC
Crash : No **Fire :** No **Number of Injuries:** 0
ODI ID Number : 10374828 **Number of Deaths:** 0
Date of Failure: November 1, 2010
VIN : 2G1WT58KX79...

Component: TIRES

Summary:

TL*THE CONTACT OWNS A 2007 CHEVROLET IMPALA LT. THE CONTACT STATED THAT WHEN SHE INSPECTED HER VEHICLE SHE NOTICED THAT ALL FOUR TIRES WERE WORN EXCESSIVELY ON THE INSIDE TO THE POINT WHERE THE TREAD WAS VISIBLE. THE VEHICLE WAS NOT INSPECTED NOR HAD IT BEEN REPAIRED. THE DEALER INFORMED HER THAT SHE SHOULD CONSIDER AN ALIGNMENT AND FOUR NEW TIRES. THE FAILURE MILEAGE WAS APPROXIMATELY 32,000.

Make : CHEVROLET **Model :** IMPALA **Year :** 2007
Manufacturer : GENERAL MOTORS LLC
Crash : No **Fire :** No **Number of Injuries:** 0
ODI ID Number : 10373348 **Number of Deaths:** 0
Date of Failure: December 1, 2010
VIN : 2G1WT58KX79...

Component: TIRES

Summary:

GM 2007 CHEVROLET IMPALA LT2 - GOODYEAR INTEGRITY TIRES VEHICLE MANUFACTURING OETECT CAUSES TIRE CUPPING, UNEVEN TIRE WEAR AND PREMATURE TIRE WEAR OUT. POSSIBLE TIRE FAILURE WHILE DRIVING IF NOT DETECTED. TIRES RATED FOR 50,000 MILES FAILED AT 28,000. 30 JUNE 2007 - 205 MILES: PURCHASED NEW GM 2007 CHEVROLET IMPALA LT2 - GOODYEAR INTEGRITY TIRES 05 FEB 2008 - 7,094 MILES: DEALER ROTATED TIRES - ALL TIRES TREAD GREATER THAN 8/32. 26 DEC 2008 - 14,449 MILES: DEALER ROTATED TIRES - ALL TIRES TREAD GREATER THAN 8/32. 15 JUN 2009 - 18,106 MILES: DEALER ROTATED TIRES - ALL TIRES TREAD GREATER THAN 8/32. 25 MAY 2010 - 23,812 MILES: DEALER ROTATED TIRES - ALL TIRES TREAD GREATER THAN 8/32. 01 DEC 2010 - 28,517 MILES: LUBE SHOP ROTATED TIRES - ALL TIRES BADLY CUPPED ON INSIDE TREAD. TIRES WORN OUT AND UNSAFE, MUST BE REPLACED ASAP. STEEL BELTS WILL START TO SHOW. ALL TIRES TREAD LESS THAN 2/32. 23 DEC 2010 - 28,788 MILES: DEALER - AFTER ESCALATION TO SERVICE MANAGER. REAR STRUT BOLT HOLE REQUIRES ELONGATION TO ALLOW PROPER WHEEL ALIGNMENT. UNDER WARRANTY, ELONGATED REAR STRUT BOLT HOLE, REPLACED WITH 4 NEW TIRES, COMPLETE 4 WHEEL ALIGNMENT. *TR

Make : CHEVROLET **Model :** IMPALA **Year :** 2007
Manufacturer : GENERAL MOTORS LLC
Crash : No **Fire :** No **Number of Injuries:** 0
ODI ID Number : 10341592 **Number of Deaths:** 0
Date of Failure: June 30, 2010
VIN : 2G1WU58R979...

Component: TIRES

Summary:

THIS INVOLVES A CONTINUED REAR TIRE ISSUE WITH MY 2007 CHEVY IMPALA LTZ THAT HAS NOT BEEN RESOLVED DESPITE ENCOUNTERS WITH DEALERS & NATIONAL TIRE ALIGNMENT SPECIALISTS 12/06: PURCHASED CAR NEW, CAME WITH GOODYEAR EAGLE LS2 RADIALS. 3/08: ONE TIRE BLEW IN CHARLOTTE, NC. AT JUST TIRES, THEY POINTED OUT THAT BOTH REAR TIRES INCLUDING THE ONE THAT BLEW HAD SIGNIFICANT SIGNS OF WEAR, REPLACED BOTH WITH LS2 RADIALS. THE PROBLEM WAS CHALKED UP TO ALIGNMENT ISSUES THAT COULD'VE STARTED FROM THE FACTORY. 11/08: AFTER MORE INCIDENTS OF LOW REAR TIRE PRESSURE, TOOK CAR INTO LOCAL JUST TIRES. TIRED OF CONTINUED ISSUES, I DECIDE TO GET TOP OF THE LINE TIRES FROM THEM (GOODYEAR ASSURANCE TRIPLETRED) FOR JUST UNDER \$900. 9/09: TIRE KEPT LOSING PRESSURE, TOOK CAR INTO LOCAL JUST TIRES. TOLD TIRES WERE NOT ONLY ONCE AGAIN OUT OF ALIGNMENT, BUT REAR TIRES AGAIN NEEDED REPLACEMENT (IN A MANNER NOT COVERED BY ROAD HAZARD PLAN) FOR \$507 WITH TREADS SEVERELY WORN DOWN. THE PROBLEM WAS AGAIN CHALKED UP TO ALIGNMENT ISSUES, THOUGH THEY ALIGNED THE TIRES IN 11/08. 6/10: RANDOMLY CHECK TREADS ON MY TOP-LINE TIRES.

COMPLETELY FINE IN FRONT, BUT WORN DOWN CONSIDERABLY ON BOTH REAR TIRES. I DRIVE ONLY CITY STREETS & HAD DRIVEN LESS THAN 12,000 MILES SINCE BUYING 4 NEW TIRES. RESEARCH UNCOVERS A PLETHORA OF REAR-END ALIGNMENT ISSUES ON 2007 CHEVY IMPALAS, INCLUDING A SPECIFIC IDENTIFIED ISSUE: [HTTP://FLEETLEADER.PHH.COM/RECALLS/2008/RECALLSJULY2008.PDF](http://fleetleader.phh.com/recalls/2008/recallsjuly2008.pdf) CUSTOMER SATISFACTION PROGRAM #08032 - UNEVEN POLICE CAR REAR TIRE WEAR OBVIOUSLY. THIS EXTENDED TO COMMERCIAL IMPALAS & EXPLAINS WHAT'S BEEN HAPPENING. WHEN CALLING PALLONE CHEVROLET, THE SERVICE REP FLATLY DISMISSES THE TALK OF THE POLICE RECALL, SAYING THAT THE SPINDLE ROD PARTS INVOLVED ARE COMPLETELY DIFFERENT. (LATER CHECKING INDICATES THE PARTS ARE EXACTLY THE SAME ON BOTH THE POLICE AND COMMERCIAL VEHICLES.) ILM TOLD THAT THE ONLY WAY THEY CAN HELP IS TO CHECK ALIGNMENT, AS IF NOTHING ELSE COULD BE CAUSING THE PROBLEM. *TR

Make : CHEVROLET **Model :** IMPALA **Year :** 2007
Manufacturer : GENERAL MOTORS LLC
Crash : No **Fire :** No **Number of Injuries :** 0
ODI ID Number : 10332159 **Number of Deaths :** 0
Date of Failure: May 23, 2010
VIN : 2G1WC58RX79...
Component: TIRES
Summary:
TREAD SEPARATED FROM TIRE, LOSS OF AIR. THIRD TIRE OF THIS SAME MAKE AND MODEL TO DO THIS. *TR

Make : CHEVROLET **Model :** IMPALA **Year :** 2007
Manufacturer : GENERAL MOTORS LLC
Crash : No **Fire :** No **Number of Injuries :** 0
ODI ID Number : 10328525 **Number of Deaths :** 0
Date of Failure: April 30, 2010
VIN : 2G1WB58K979...
Component: TIRES

Summary:
2007 CHEVROLET IMPALA. PREMATURE TIRE WEAR*CW THE CONSUMER ALSO HAS ANOTHER COMPLAINT WITH A DIFFERENT VEHICLE. ODI # 10334853. UPDATED 06/04/10.*JB THE CONSUMER IS REQUESTING AN INSPECTION OF THE VEHICLE. HE WOULD LIKE THE STRUTS AND FRONT END TO BE INSPECTED. UPDATED 08/12/10*JB

Make : CHEVROLET **Model :** IMPALA **Year :** 2007
Manufacturer : GENERAL MOTORS LLC
Crash : No **Fire :** No **Number of Injuries :** 0
ODI ID Number : 10322765 **Number of Deaths :** 0
Date of Failure: April 5, 2008
VIN : 2G1WT58K179...
Component: TIRES

Summary:
I PURCHASED THIS CAR IN APRIL OF '08 AND IT HAS BEEN FAILING SINCE I BOUGHT IT. THERE IS A VIBRATION WHILE RIDING IN THE CAR THAT MAKES YOUR BODY BOUNCE. THE DEALER STATES THEY DONT FEEL IT, BUT I HAVE CRONIC BACK PAIN FROM IT. I HAVE HAD IT AT THE DEALER SEVERAL TIMES AND NO FIX. I TOOK IT TO AN ALINEMENT SHOP THEY TOLD ME THAT THE STUTS WERE SET OUT FROM THE FACTORY SO THE TIRES DONT HIT THE GROND FLAT LIKE THEY SHOULD. THE PROBLEM CAUSES MY TIRES TO SLIP OUT OF BALANCE CONSTANTLY MAKING THE VIBRATION WORSE. MY WINDSHIELD AND DASH BOTH MAKE CRAKING NOISES NOW FROM ALL THE VIBRATION IN THE CAR. IT MAKES FOR A VERY UNCOMFORTABLE RIDE. I AM ON MY 3RD SET OF TIRES AT 28,300. THE BRAKES DONT WORK PROPERLY, THE DEALER HAS TURNED THE ROTORS TWICE FOR WARPING. NOW THEY ARE GROOVED AND THEY TELL ME THAT "IT'S NORMAL" AND I DONT HAVE THE NORMAL STOPING POWER I SHOULD. THE POWER STERING SQUIELS, BUT THEY CANT HEAR IT. THE FRONT END HAS A BANGING NOISE WHEN GOING OVER BUMPS,"THEY DONT HEAR", BUT I CAN FEEL IT IN THE FLOOR BOARD WHEN IT HAPPENS. THE CAR IS SLUGGISH WHEN EXCELERATING,"ND PROBLEM FOUND". THE FUEL ECONOMY HAS DECREASED AS WELL. WHILE ON AN INCLINE THE CAR ROLES BACKWARD LIKE A STANDARD,"IT'S NORMAL" I HAVE NEVER HAD A CAR DO THAT WITHOUT THE TRANY BEING BAD. WHEN STOPED AT A LIGHT THE TRANY TAKES A COUPLE OF SECONDS TO REENGAGE FOR TAKE OFF. TPS REPEATED PROBLEMS NOT WORKING POPERLY. THE CARS HANDLING IS VERY POOR IN THE RAIN,SNOW,OR ICE. THE MUFFLER SYSTEM HAS A LEAK AS WELL.

Make : CHEVROLET **Model :** IMPALA **Year :** 2007
Manufacturer : GENERAL MOTORS LLC
Crash : No **Fire :** No **Number of Injuries :** 0

ODI ID Number : 10310699

Number of Deaths: 0

Date of Failure: February 10, 2010

VIN : 2G1WC58RX79...

Component: TIRES

Summary:

I DID NOT REALIZE SUCH A WEBSITE EXISTED. I HAVE PURCHASED MANY NEW VEHICLES AND HAVE ALWAYS BEEN HAPPY UNTIL I PURCHASED MY 2007 IMPALA BRAND NEW WITH 27 MILES. I STARTED LOOKING ON THE INTERNET DUE TO "STEERING" PROBLEM AND FOUND THIS WEBSITE. YOU CAN BE DRIVING DOWN THE ROAD AND THE STEERING WHEEL WILL LOCK UP AND NOT MOVE FOR SEVERAL SECONDS. IT WOULD BE VERY EASY TO HAVE AN ACCIDENT YOU NEED THE WHEELS TO TURN, BUT THE WHEEL WANTS TO MOVE. I THINK MY HUSBAND THOUGHT I WAS CRAZY UNTIL HE HAPPENED TO BE WITH ME THE OTHER DAY AND WITNESSED THIS. I HAVE NOTICED THAT ALL 5 TIMES THIS HAS HAPPENED IT HAS BEEN RAINING OUT. THE 1ST 2 TIMES WERE PROBABLY A YEAR AGO, BUT IT HAS HAPPENED 3 TIMES IN THE LAST 2 MONTHS. I HAVE ALSO HAD THE TIRE ISSUE, DID NOT THINK ABOUT IT BEING THE CAR, BUT I HAVE HAD 3 SETS OF BRAND NEW TIRES ON THIS VEHICLE. SAME PROBLEM SOMEONE ELSE MENTIONED THE REAR TIRES WEAR COMPLETELY OUT ON THE INSIDE. I HAD WIRES HANGING OUT ON 1 YEAR OLD TIRES. I DO NOT FEEL SAFE AT ALL IN THIS VEHICLE AND CAN'T IMAGINE ANYONE WANTING TO DRIVE A VEHICLE THAT THE STEERING LOCKS UP. I HAVE 2 PRECIOUS CHILDREN AND AM NOT HAPPY WITH THIS. I STILL OWE A TREMENDOUS AMOUNT ON THE VEHICLE SO I DON'T REALLY HAVE ANY OPTIONS BUT TO REPORT TO SOMEONE THAT MIGHT BE ABLE TO HELP. THANKS! THE STRUCTURE- THE DOOR MOLDING JUST FELL OFF ON THE DRIVERS SIDE ONE DAY. *TR

Make : CHEVROLET

Model : IMPALA

Year : 2007

Manufacturer : GENERAL MOTORS LLC

Crash : No

Fire : No

Number of Injuries: 0

ODI ID Number : 10297637

Number of Deaths: 0

Date of Failure: September 15, 2009

VIN : 2G1WD58C279...

Component: TIRES

Summary:

EXCESSIVE TIRE WEAR ON REAR TIRES—NOTICED THERE WAS A PROBLEM AT 22,000 MILES AT 27,000 MILES CAR WOULD NOT HOLD THE ROAD. IN THE DEAD OF SUMMER CAR DROVE LIKE YOU WERE ON A LAKE OF ICE (2007 CHEVY SS IMPALA) TALKED TO DEALERS THEY SAID NOT A REPORTED PROBLEM FOUND OUT LATER THAT WAS A SUSPENSION PROBLEM. ITS A SUSPENSION PROBLEM. SO MUCH SO THERE IS AN AFTER MARKET KIT TO CORRECT PROBLEM HAD TO TAKE CAR TO TIRE DEALER WHERE THEY CORRECTED PROBLEM. REPORTED PROBLEM TO G.M. AND GOT MORE INFORMATION. *TR

Make : CHEVROLET

Model : IMPALA

Year : 2007

Manufacturer : GENERAL MOTORS LLC

Crash : No

Fire : No

Number of Injuries: 0

ODI ID Number : 10294556

Number of Deaths: 0

Date of Failure: April 3, 2008

VIN : 2G1WD58C179...

Component: TIRES

Summary:

I PURCHASED EAGLE F1 (235/50ZR18) TIRES FROM THE CORPORATE GOODYEAR STORE IN RICHMOND, VIRGINIA ON APRIL 3, 2008. IN LESS THAN ONE YEAR, FOUR TIRES WERE REPLACED DUE TO CUPPING. I RESEARCHED THE INTERNET AND DISCOVERED OTHER COMPLAINTS ABOUT EAGLE F1 CUPPING ISSUES. NOW, TWO ADDITIONAL EAGLE F1 TIRES HAVE CUPPED. I HAVE PAID A PRORATED COST FOR FOUR ADDITIONAL TIRES, NOW TWO ADDITIONAL TIRES HAVE CUPPED. I DISCOVERED CUSTOMERS WHO PURCHASED GOODYEAR EAGLE F1 TIRES FROM TIRE RACK RECEIVED FOUR NEW TIRES AT NO COST PLUS A \$100 PER TIRE PAYMENT TO OFFSET TIRE MOUNTING, FREIGHT AND BALANCING. TO DATE, I HAVE SPENT \$1,995.99 FOR EIGHT EAGLE F1 TIRES WITH CUPPING ISSUES. GOODYEAR OFFERED TO REPLACE THE FOUR EAGLE F1S CURRENTLY ON MY CAR WITH FOUR NON EAGLE F1 TIRES FOR \$722.00. GOODYEAR DENIES A TIRE RECALL. THE MANAGER INDICATED THE EAGLE F1S AS ONE OF GOODYEAR'S BEST TIRES, HOWEVER, THEY ARE NO LONGER ON DISPLAY IN HIS STORE. GOODYEAR HAS YET TO OFFER ADEQUATE COMPENSATION BASED ON THAT RECEIVED BY CUSTOMERS OF TIRE RACK, WHICH IS NOT A GOODYEAR CORPORATE STORE. *TR

Make : CHEVROLET

Model : IMPALA

Year : 2007

Manufacturer : GENERAL MOTORS LLC

Crash : No

Fire : No

Number of Injuries: 0

ODI ID Number : 10294195

Number of Deaths: 0

Date of Failure: November 30, 2009

VIN : 2G1WT55N079...

Component: TIRES

Summary:

I AM NOW BUYING THE 3RD SET OF REAR TIRES IN LESS THAN A YEAR. THE INSIDE TREAD WEARS

DOWN TO THE WIRES EVERY 13-16,000 MILES. THE VIN ON MY CAR FALLS WITHIN THE VIN'S LISTED ON GM TSB 8032, HOWEVER THIS CAR IS NOT A POLICE CAR. GM STATES THAT I MUST BE HITTING A POTHOLE CAUSING ALIGNMENT PROBLEMS. I MUST BE HITTING THE SAME POTHOLE AT THE SAME MILEAGE ALL 3 TIMES AND IT ONLY AFFECTS THE REAR TIRES. THERE IS EXTENSIVE ANECDOTAL REFERENCES TO THIS PROBLEM ON NUMEROUS CAR COMPLAINT WEBSITES, INCLUDING NHTSA. SOMEONE IS GOING TO GET SERIOUSLY HURT IF GM IS ALLOWED TO IGNORE THIS PROBLEM. GM'S ONLY SOLUTION IS TO SELL ME ALIGNMENTS AND TIRES SINCE IT IS "MY FAULT" AND EVEN THOUGH THE PROBLEM IS IDENTICAL TO THE ISSUE NOTED BY GM IN TSB 8032, IT CAN'T POSSIBLY BE RELATED SINCE THE OTHER IDENTICAL PROBLEM ONLY HAPPENS ON POLICE AND GOVERNMENT CARS TO WHICH GM SELLS A LOT OF CARS. THE EVERYDAY INDIVIDUAL DOES NOT HAVE THE COMPLAINING POWER OF A LARGE BULK PURCHASER. *TR

Make : CHEVROLET **Model :** IMPALA **Year :** 2007
Manufacturer : GENERAL MOTORS LLC
Crash : No **Fire :** No **Number of Injuries :** 0
ODI ID Number : 10283874 **Number of Deaths :** 0
Date of Failure: September 14, 2009
VIN : 2G1WT58N579...
Component: TIRES
Summary:
 THE TIRES ON MY 2007 CHEVY IMPALA WEAR ON THE INSIDE AND NOT ON THE CENTER OR OUTSIDE. *TR

Make : CHEVROLET **Model :** IMPALA **Year :** 2007
Manufacturer : GENERAL MOTORS LLC
Crash : No **Fire :** No **Number of Injuries :** 0
ODI ID Number : 10283778 **Number of Deaths :** 0
Date of Failure: September 11, 2009
VIN : 2G1WT58K479...
Component: TIRES
Summary:
 TIRES WEARING ON INSIDE TREAD OF ALL FOUR TIRES. *TR

Make : CHEVROLET **Model :** IMPALA **Year :** 2007
Manufacturer : GENERAL MOTORS LLC
Crash : No **Fire :** No **Number of Injuries :** 0
ODI ID Number : 10282752 **Number of Deaths :** 0
Date of Failure: January 10, 2007
VIN : Not Available
Component: TIRES
Summary:
 BACK END OF 2007 CHEVY IMPALA SLIPS ON WATER AND SNOW, FEELS LIKE I'M ON AN ICE RINK. NEVER FELT THIS IN THE 32 YEARS DRIVING CARS. THE TIRES WEAR ON THE INSIDE AND CAMBER LOOKS WAY OFF. *TR

Make : CHEVROLET **Model :** IMPALA **Year :** 2007
Manufacturer : GENERAL MOTORS LLC
Crash : No **Fire :** No **Number of Injuries :** 0
ODI ID Number : 10263341 **Number of Deaths :** 0
Date of Failure: December 27, 2008
VIN : 2G1WC58R379...
Component: TIRES
Summary:
 VIBRATION AND PULLING ON HIGHWAY IN SPEEDS ABOVE 60MPH. HAD TIRES ROTATED/BALANCED AND NUMEROUS ALIGNMENTS PERFORMED WITHOUT RESOLUTION. THIRD PARTY INSPECTED TIRES AND FOUND "TREAD SEPARATION" ON 3 OF THE 4 TIRES. TIRES EXHIBITED THESE PROBLEMS SINCE ABOUT 29000 MILES AND WERE REPLACED AT 36000. *TR

Make : CHEVROLET **Model :** IMPALA **Year :** 2007
Manufacturer : GENERAL MOTORS LLC

VIN : Not Available

Component: TIRES

Summary:

TL*THE CONTACT OWNS A 2007 CHEVROLET IMPALA. THE VEHICLE HAS GOODYEAR INTEGRITY, SIZE 175/70R13 TIRES. WHILE DRIVING 30 MPH IN THE SNOW, THE VEHICLE BEGAN TO SLIDE. THE FAILURE ALSO OCCURRED IN WET AND ICY CONDITIONS. THE DEALER STATED THAT THE TIRES WERE DEFECTIVE AND NEEDED TO BE REPLACED; HOWEVER, THEY DID NOT SPECIFY THE REASON. THE DOT NUMBER, VIN, ENGINE SIZE, AND NUMBER OF CYLINDERS WERE UNKNOWN. THE CURRENT AND FAILURE MILEAGES WERE 25,000.

Make : CHEVROLET

Model : IMPALA

Year : 2007

Manufacturer : GENERAL MOTORS LLC

Crash : No

Fire : No

Number of Injuries: 0

ODI ID Number : 10219216

Number of Deaths: 0

Date of Failure: February 25, 2008

VIN : 2G1WS55RX79...

Component: TIRES

Summary:

REAR ALIGNMENT NOT WITHIN SPECS FROM FACTORY, CAUSED REAR TIRES TO WEAR OUT PREMATURELY. FRONT DISK BRAKE ROTORS AND BRAKES UNREPAIRABLE AT 11,000 MILES. CHEVROLET WOULD NOT COVER REPAIRS UNDER WARRANTY. *TR

Make : CHEVROLET

Model : IMPALA

Year : 2007

Manufacturer : GENERAL MOTORS LLC

Crash : No

Fire : No

Number of Injuries: 0

ODI ID Number : 10213183

Number of Deaths: 0

Date of Failure: December 27, 2007

VIN : 2G1WT58N679...

Component: TIRES

Summary:

GOODYEAR INTEGRITY 225/60R16 TIRE GOT FLAT TIRE FROM SMALL PLASTIC DEBRIS. WHEN TIRE WAS REPAIRED IT WAS POINTED OUT THE TIRE IS OVER HALF WORN AT JUST BARELY 9,000 MILES. TIRE IF KEPT ON VEHICLE WILL REQUIRE REPLACEMENT BEFORE 17,000 MILES. ALSO TIRE HANDLES POORLY IN ALL CONDITIONS. VERY LOOSE HANDLING AND EXCESSIVE TIRE NOISE ON CORNERS EVEN AT SLOW SPEEDS. *TR

Make : CHEVROLET

Model : IMPALA

Year : 2007

Manufacturer : GENERAL MOTORS LLC

Crash : No

Fire : No

Number of Injuries: 0

ODI ID Number : 10208882

Number of Deaths: 0

Date of Failure: October 30, 2007

VIN : Not Available

Component: TIRES

Summary:

WITHIN 6 MONTHS OF LEASING A 07 IMPALA, THERE HAS BEEN THREE SEPARATE OCCASIONS MY TIRE HAS LOST ALL AIR PRESSURE WHILE PARKED WITHIN HOURS. 1ST INSTANCE: BETWEEN 10 A.M. AND 1 P.M. THE TIRE LOST AIR TO WHERE THE RIM WAS TOUCHING THE GROUND. 2ND INSTANCE: LOST 1/2 OF AIR OVERNIGHT - AGAIN THE RIM TOUCHED THE GROUND. I HAD PEP BOYS AND THE DEALERSHIP WHERE I AM LEASING THE VEHICLE EXAMINE THE TIRE AND BOTH SAID NOTHING WAS WRONG WITH THE TIRE AND IT WAS PROBABLY SOMEONE LETTING THE AIR OUT OF THE TIRE. THIRD INSTANCE: I LEFT MY VEHICLE IN THE GARAGE OVERNIGHT AND WOKE UP TO THE RIM TOUCHING THE GROUND. THIS RULED OUT SOMEONE LETTING THE AIR OUT OF THE TIRE. I AGAIN TOOK IT TO THE CHEVY DEALERSHIP WHO I AM LEASING THROUGH, AND ONCE AGAIN, I WAS TOLD NOTHING WAS WRONG WITH THE TIRE. *TR

1200 New Jersey Avenue, SE, West Building Washington DC 20590 USA
1.888.327.4236 TTY 1.800.424.9153



Manufacturer : GENERAL MOTORS LLC**Crash :** No**Fire :** No**Number of Injuries :** 0**ODI ID Number :** 10378355**Number of Deaths :** 0**Date of Failure:** December 13, 2010**VIN :** 2G1WT58N979...**Component:** SUSPENSION:REAR**Summary:**

FIRST SNOW STORM I DROVE THIS CAR IN, THE CARS REAR END SLIDES ALL OVER THE ROAD. I HAVE DRIVEN IN SNOW ALL MY LIFE AND THIS WAS THE SCARIEST VEHICLE I HAVE EVER DROVE IN SLICK WEATHER. I CHANGED THE TIRES BELIEVING THIS WAS THE PROBLEM ONLY TO SEE THAT THE REAR TIRES ARE BOTH WEARING ON THE INSIDE. AFTER HAVING THIS CAR FOR OVER A YEAR THE REAR END FEELS LIKE IT SLIDES BACK AND FORTH AND IS AT ITS WORST IN RAIN AND ESPECIALLY SNOW. I SEE THERE ARE MANY COMPLAINTS OF THIS KIND FOR THIS CAR. THE REAR END SLIDING AROUND AND THE INNER TIRES ON THE REAR END WEARING OUT QUICKLY. I REALLY LIKE EVERYTHING ELSE ABOUT THIS CAR AND I HAVE A TRUCK THAT I DRIVE DURING BAD WEATHER. I WOULD HOPE THAT CHEVROLET WOULD DO SOMETHING TO FIX THIS PROBLEM. I WILL SELL OR TRADE THE CAR BEFORE I WILL EVER DRIVE IT IN SNOW AND I CANNOT AFFORD TO KEEP TIRES ON THE REAR END. *LN

[Document Search](#) Check to Request Research. Submit below.**Make :** CHEVROLET**Model :** IMPALA**Year :** 2007**Manufacturer :** GENERAL MOTORS LLC**Crash :** No**Fire :** No**Number of Injuries :** 0**ODI ID Number :** 10375501**Number of Deaths :** 0**Date of Failure:** January 9, 2011**VIN :** 2G1WT58K779...**Component:** SUSPENSION:REAR**Summary:**

2007 CHEVY IMPALA - REAR SUSPENSION PROBLEM RESULTS IN DANGEROUS STABILITY ISSUES IN ICE, SNOW, AND RAIN. THE REAR END OF THE CAR SLIDES AROUND MAKING IT DIFFICULT TO STAY ON THE ROAD AND IN MY LANE. ALSO RESULTS IN UNEVEN AND FAST TIRE WEAR. GM HAS ADMITTED THERE IS AN ISSUE (BULLETIN 08032), BUT WILL ONLY APPLY TO GOVERNMENT CARS. *TR

[Document Search](#) Check to Request Research. Submit below.**Make :** CHEVROLET**Model :** IMPALA**Year :** 2007**Manufacturer :** GENERAL MOTORS LLC**Crash :** No**Fire :** No**Number of Injuries :** 0**ODI ID Number :** 10373348**Number of Deaths :** 0**Date of Failure:** December 1, 2010**VIN :** 2G1WT58KX79...**Component:** SUSPENSION:REAR**Summary:**

GM 2007 CHEVROLET IMPALA LT2 - GOODYEAR INTEGRITY TIRES VEHICLE MANUFACTURING DETECT CAUSES TIRE CUPPING, UNEVEN TIRE WEAR AND PREMATURE TIRE WEAR OUT. POSSIBLE TIRE FAILURE WHILE DRIVING IF NOT DETECTED. TIRES RATED FOR 50,000 MILES FAILED AT 28,000. 30 JUNE 2007 - 205 MILES: PURCHASED NEW GM 2007 CHEVROLET IMPALA LT2 - GOODYEAR INTEGRITY TIRES 05 FEB 2008 - 7,094 MILES: DEALER ROTATED TIRES - ALL TIRES TREAD GREATER THAN 8/32. 26 DEC 2008 - 14,449 MILES: DEALER ROTATED TIRES - ALL TIRES TREAD GREATER THAN 8/32. 15 JUN 2009 - 18,106 MILES: DEALER ROTATED TIRES - ALL TIRES TREAD GREATER THAN 8/32. 25 MAY 2010 - 23,812 MILES: DEALER ROTATED TIRES - ALL TIRES TREAD GREATER THAN 6/32. 01 DEC 2010 - 28,517 MILES: LUBE SHOP ROTATED TIRES - ALL TIRES BADLY CUPPED ON INSIDE TREAD. TIRES WORN OUT AND UNSAFE, MUST BE REPLACED ASAP. STEEL BELTS WILL START TO SHOW. ALL TIRES TREAD LESS THAN 2/32. 23 DEC 2010 - 28,788 MILES: DEALER - AFTER ESCALATION TO SERVICE MANAGER. REAR STRUT BOLT HOLE REQUIRES ELONGATION TO ALLOW PROPER WHEEL ALIGNMENT. UNDER WARRANTY, ELONGATED REAR STRUT BOLT HOLE. REPLACED WITH 4 NEW TIRES, COMPLETE 4 WHEEL ALIGNMENT. *TR

[Document Search](#) Check to Request Research. Submit below.

Make : CHEVROLET **Model :** IMPALA **Year :** 2007
Manufacturer : GENERAL MOTORS LLC
Crash : No **Fire :** No **Number of Injuries:** 0
ODI ID Number : 10373190 **Number of Deaths:** 0
Date of Failure: December 28, 2010
VIN : 2G1WT58N079...
Component: SUSPENSION:REAR

Summary:

THE 2007 CHEVROLET IMPALA IS AN EXTREMELY UNSAFE AUTOMOBILE IN WET OR SNOW/ICE CONDITIONS. EVEN SAND OR SALT; THIS CAR IS THE WORST HANDLING AUTOMOBILE POSSIBLY EVER DESIGNED BY GM. THE IMPALA'S REAR END SLIDES LEFT OR RIGHT WITH ONLY A MINIMAL AMOUNT OF DEBRIS, WATER, OR SNOW ON THE ROAD. THIS IS NOT JUST A LITTLE SLIP NOW AND AGAIN, IT IS UNCONTROLLABLE AND AN EXTREME SAFETY HAZARD. EVERY PERSON THAT HAS HAD ANY DEALINGS WITH THIS TYPE OF CAR WILL TELL YOU THE SAME THING. ASK ANY MECHANIC, DEALERSHIP, TIRE SALES REP, AND MOST OF ALL, A 2007 CHEVY IMPALA OWNER AND ALL WILL ATTEST TO THE POOR DESIGN OF THIS CAR. MY WIFE AND I WILL NOT, OR SHOULD SAY CANNOT, DRIVE THIS CAR WHEN THERE IS ANY SIGN OF RAIN OR SNOW IN THE FORECAST. SOMETHING MUST BE DONE ABOUT THIS CAR. NOT ONLY IS THERE A HANDLING PROBLEM, BUT TIRE WEAR IS ALMOST UNBELIEVABLE. THE ALIGNMENT SPECIFICATIONS ARE AT SUCH EXTREMES THAT TIRES ARE RUINED IN 10,000 MILES OR LESS. WHEN LOOKING AT THE CAR FROM THE REAR, THE IMPALA'S WHEELS TILT IN TO THE POINT IT LOOKS AS THOUGH THEY COULD COLLAPSE INWARD UNDER THE CAR. I HAVE HAD THE DEALERSHIP AND TWO DIFFERENT ALIGNMENT SHOPS CHECK THE ALIGNMENT AND ALL SAY THE SAME; THE CAR IS WITHIN SPECS AND TO BE EXTRA CAREFUL AS THAT THE HANDLING OF THESE CARS ARE UNSAFE. WHAT GIVES? DOES IT TAKE A FATALITY TO OCCUR BEFORE GM WILL DO ANYTHING ABOUT THIS DESIGN FLAW? PLEASE LOOK INTO THIS MATTER, LIVES DEPEND ON IT. ANYONE, AND I MEAN ANYONE, WHO DRIVES THIS CAR CANNOT DENY THERE IS SOMETHING SERIOUSLY WRONG THE 2007 CHEVROLET IMPALA. A FINAL NOTE, IT WAS BROUGHT TO MY ATTENTION THAT ALL POLICE CARS OF THIS TYPE WERE RECALLED FOR THIS VERY PROBLEM, IS THAT INDEED THE CASE? IF SO, WHAT ABOUT MY FAMILY'S SAFETY AND EVERY OTHER FAMILY THAT OWNS ONE OF THESE CARS? DO WE NOT DESERVE THE SAME PROTECTION? *TR

 Check to Request Research. Submit below.

Make : CHEVROLET **Model :** IMPALA **Year :** 2007
Manufacturer : GENERAL MOTORS LLC
Crash : No **Fire :** No **Number of Injuries:** 0
ODI ID Number : 10359246 **Number of Deaths:** 0
Date of Failure: October 5, 2010
VIN : 2G1WB58K179...
Component: SUSPENSION:REAR

Summary:

HAD CLUNK NOISE COMING FROM REAR SUSPENSION WHEN GOING OVER EVEN THE SMALLEST BUMP OR CRACK IN THE ROAD. TOOK BACK TO DEALER AND THEY FOUND THE CROSS MEMBERS OF THE CHASSIS - BOLTS HAD WORKED LOOSE. THEY TIGHTENED THEM. NO MORE NOISE SO FAR. *TR

 Check to Request Research. Submit below.

Make : CHEVROLET **Model :** IMPALA **Year :** 2007
Manufacturer : GENERAL MOTORS LLC
Crash : No **Fire :** No **Number of Injuries:** 0
ODI ID Number : 10348865 **Number of Deaths:** 0
Date of Failure: July 12, 2010
VIN : 2G1WT58K179...
Component: SUSPENSION:REAR

Summary:

I'VE HAD TO REPLACE REAR TIRES EVERY 23,000 MILES. TOOK CAR TO CHEVY DEALER AND HE TOLD ME THAT THE HOLES FOR THE STRUTS WOULD HAVE TO BE ELONGATED AND MODIFIED WITH A CAMBER KIT AT MY EXPENSE OR ELSE THE REAR ALIGNMENT WOULD NOT BE ACCORDING TO SPECS. I PAID FOR FRONT AND REAR ALIGNMENT, CHEVY WILL NOT PAY FOR THIS UNLESS ITS A POLICE CAR. IT IS A FACTORY DEFECT, THERE ARE A LOT OF THE SAME MODEL YEAR CHEVROLETS WITH THE SAME PROBLEM. *TR

 Check to Request Research. Submit below.

Date of Failure: November 1, 2009

VIN : 2G1WB58K179...

Component: SUSPENSION:REAR

Summary:

THERE IS A REAR SUSPENSION ALIGNMENT ISSUE ON THIS VEHICLE. THE REAR WHEELS ARE KICKED-OUT CAUSING INNER WEAR ON THE TIRES AFTER MINIMAL MILEAGE. I WAS FORCED TO REPLACE ALL FOUR TIRES (BECAUSE THEY HAD BEEN ROTATED) AFTER ONLY 25K MILES. *TR

[Document Search](#) Check to Request Research. Submit below.

Make : CHEVROLET

Model : IMPALA

Year : 2007

Manufacturer : GENERAL MOTORS LLC

Crash : No

Fire : No

Number of Injuries: 0

ODI ID Number : 10313991

Number of Deaths: 0

Date of Failure: February 24, 2010

VIN : 2G1WD58C979...

Component: SUSPENSION:REAR

Summary:

I AM HAVING EXCESSIVE WEAR ON THE INSIDE OF BOTH REAR TIRES. I HAVE REPLACED MY REAR TIRES TWICE IN LESS THAN 5 MONTHS. BOTH OF MY REAR TIRES BLEW OUT AT THE SAME TIME ON 2/24/10 WHILE I WAS DRIVING ON THE HIGHWAY. THERE HAS BEEN A RECALL ON THE POLICE VEHICLES FOR THE SAME ISSUE WHICH TURNS OUT TO BE ALIGNMENT ISSUES. I AM FEARFUL FOR MY SAFETY IN THIS CAR ALONG WITH THE EXPENSES BEING INCURRED DUE TO A POOR QUALITY PRODUCT. *TR

[Document Search](#) Check to Request Research. Submit below.

Make : CHEVROLET

Model : IMPALA

Year : 2007

Manufacturer : GENERAL MOTORS LLC

Crash : No

Fire : No

Number of Injuries: 0

ODI ID Number : 10299652

Number of Deaths: 0

Date of Failure: December 20, 2009

VIN : 2G1WT58KX79...

Component: SUSPENSION:REAR

Summary:

TL*THE CONTACT OWNS A 2007 CHEVY IMPALA. HE STATED THAT WHEN SNOW AND ICE ARE ON THE ROAD THE REAR END OF THE VEHICLE WOULD SLIDE "VERY DANGEROUSLY". WHILE DRIVING AT SPEEDS OF LESS THAN 30 MPH, THE REAR END OF THE VEHICLE WOULD SWING OUTWARD WHENEVER HE WOULD DRIVE OVER A SHEET OF ICE, SNOW OR DURING INCLEMENT WEATHER CONDITIONS. THE DEALER STATED THAT THE TIRES NEEDED TO BE ALIGNED AND ROTATED. NO REPAIRS WERE MADE TO DATE. THE FAILURE AND CURRENT MILEAGES WERE UNDER 104,000.

[Document Search](#) Check to Request Research. Submit below.

Make : CHEVROLET

Model : IMPALA

Year : 2007

Manufacturer : GENERAL MOTORS LLC

Crash : No

Fire : No

Number of Injuries: 0

ODI ID Number : 10298365

Number of Deaths: 0

Date of Failure: November 27, 2009

VIN : 2G1WT58N379...

Component: SUSPENSION:REAR

Summary:

CAR IS TERRIBLE ON ICE,VERY UNSAFE UNDER ANY ADVERSE CONDITIONS. *TR

[Document Search](#) Check to Request Research. Submit below.

Date of Failure: December 9, 2008

VIN : 2G1WC58R079...

Component: SUSPENSION:REAR

Summary:

I PURCHASED 2007 CHEVY IMPALA WITH 32,000 MILES. I BOUGHT THIS AT A GM AUTHORIZED DEALER. HOW CAN THEY SELL A CAR WITH AN ALIGNMENT ISSUE. AT 40,000 MILES THE INSIDE OF THE REAR TIRES ARE ALMOST BALD. I CALLED GM AND GOT A CASE NUMBER OF 71-886232146 THEY STATED THAT I WOULD HAVE TO GO AND PAY A DEALERSHIP \$100 TO DO A DIAGNOSTIC ON THE CAR AND THEY WOULD THEN AT THAT TIME DO A REVIEW IF THEY WOULD COVER THE REPAIRS OR NOT. UPON RESEARCHING ON THE INTERNET I HAVE FOUND SEVERAL OTHER PEOPLE WITH THE SAME PROBLEM ON THIS CAR. GM IS ADMITTING THIS IS A PROBLEM ON THE POLICE VERSION OF THE CAR. THE PART NUMBERS FOR THE SPINDLE ROD IS THE SAME ON BOTH CARS. I BELIEVE GM ISN'T FIXING CIVILIAN CARS DUE TO WE DONT HAVE UNLIMITED MONEY AND LAWYERS LIKE THE CITY, STATE AND GOVERNMENT. I NOTICED THIS ON TUESDAY DECEMBER 9TH 2008 ON AN ICY ROAD. AT 30 MPH, IT FEELS LIKE THE REAR END WANTS TO PASS YOU OR LIKE AS IF YOU WERE PULLING A TRAILER THAT WAS VIOLENTLY WIPING BACK AND FORTH. WHEN I WENT FROM DRY PAVEMENT TO ICY PAVEMENT THE CAR WENT SIDEWAYS. I HAD MADE AN APPOINTMENT WITH COUNTRY SIDE MOTORS IN WELLINGTON KANSAS 67152 PHONE 620-326-7433 AND SPOKE WITH THE SERVICE MANAGER RON. WE MADE AN APPOINTMENT FOR THE NEXT DAY. HE CALLED ME BACK 15 MINUTES LATER AFTER LOOKING AT THE RECALL FOR THE POLICE VERSION AND SAID HE DIDNT LIKE MY ATTITUDE THE LAST TIME WE TALKED ON A DIFFERENT ISSUE "IT WAS ABOUT THE TIRE PRESSURE MONITORING SYSTEM BEING OFF, HE SAID MY TIRE WERE OVER INFLATED AND TO NOT GO BY WHAT THE TIRE MANUFACTURER SAYS BUT GO BY WHAT GM SAYS TO INFLATE TO. I TOLD HIM NOT SO AND AN EXAMPLE OF IT WAS FORD ALSO THOUGHT THEY KNEW BETTER THAN THE TIRE COMPANIES AND THEY WERE WRONG TOO." SO HE TOLD ME THAT COUNTRY SIDE WAS WASHING THEIR HANDS OF ME AND MY ISSUES AND HUNG UP THE PHONE. I BELIEVE THIS TO BE A SERIOUS SAFETY ISSUE WITH THE CAR. A PERSON COULD INVOLUNTARILY SWERVE AND HIT AN ONCOMING CAR. THE PARTS ARE \$250.00 PLUS INSTALL AND NEW TIRES. *TR

Document Search

 Check to Request Research. Submit below.

Make : CHEVROLET

Model : IMPALA

Year : 2007

Manufacturer : GENERAL MOTORS LLC

Crash : No

Fire : No

Number of Injuries: 0

ODI ID Number : 10245842

Number of Deaths: 0

Date of Failure: June 1, 2008

VIN : 2G1WC58R979...

Component: SUSPENSION:REAR

Summary:

I BOUGHT A 2007 IMPALA WITH 16,000 MILES ON FROM A SMALL DEALER IN MAY 2008, IT WAS A PREVIOUS RENTAL VEHICLE. SOON AFTER THAT, SOMEONE BROUGHT TO MY ATTENTION THAT THE TOP OR THE REAR TIRES SEEMED TILTED TOWARD THE VEHICLE AND THE BOTTOM TILTED AWAY. (OUT OF PLUMB). THE VEHICLE SEEMED TO DRIVE FINE SO I THOUGHT IT WAS NORMAL FOR THIS VEHICLE. AT ABOUT 25,000 MILES I NOTICED THE INNER SIDES OF THE REAR TIRES SHOWING EXCESSIVE WEAR, AT 28,000, THE TIRE BELTS WERE SHOWING ON THE INNER 2 INCHES OF THE TIRE. THE OUTER TREADS LOOK GREAT. I CONTACTED THE DEALER THAT I BOUGHT IT FROM AND THEY SAID THAT IT WAS AN ALIGNMENT PROBLEM AND THAT I SHOULD CONTACT GM AS IT SHOULD BE UNDER THE FACTORY WARRANTY. I'M NOW WAITING ON AN APPOINTMENT WITH MY LOCAL GM DEALER NEXT WEEK. AFTER RESEARCHING THIS ON YOUR WEB SITE I'M SEEING A REAL PROBLEM WITH THIS. I TOO FEAR FOR THE SAFETY OF ME OR ANYONE ELSE THAT MIGHT HAVE THIS PROBLEM WITH THEIR 2007 IMPALA. I HAVE NOT CONFIRMED IF THIS IS A RECALL ISSUE OR NOT, BUT IT SHOULD BE. PLEASE HELP! *TR

Document Search

 Check to Request Research. Submit below.

Make : CHEVROLET

Model : IMPALA

Year : 2007

Manufacturer : GENERAL MOTORS LLC

Crash : No

Fire : No

Number of Injuries: 0

ODI ID Number : 10244623

Number of Deaths: 0

Date of Failure: May 13, 2008

VIN : Not Available

Component: SUSPENSION:REAR

Summary:

I HAVE A 2007 CHEVY IMPALA. BOUGHT IT IN NOV 2007 WITH 13,000 MILES. I NOTICED ALL WINTER DRIVING ON SNOW AND ICE., THAT IT WAS HANDLING TERRIBLE, WAS SWAYING ALL OVER. CONTRIBUTED IT TO THE EXCESSIVE SNOW. IN MAY 2008 MY CHECK ENGINE LIGHT WAS ON TOOK IT TO THE DEALERSHIP AND THEN WAS TOLD BOTH OF MY REAR TIRES WERE WORN DOWN ON THE INSIDE DOWN TO THE METAL. I NOW HAVE 19,000 MILES ON IT. REAR TIRES HAD TO BE REPLACED AND AN ALIGNMENT. I ASK HOW THIS COULD HAPPEN

Make : CHEVROLET	Model : IMPALA	Year : 2007
Manufacturer : GENERAL MOTORS LLC		
Crash : No	Fire : No	Number of Injuries: 0
		Number of Deaths: 0
ODI ID Number : 10219216		
Date of Failure: February 25, 2008		
VIN : 2G1WS55RX79...		
Component: SUSPENSION:REAR		

Summary:
 REAR ALIGNMENT NOT WITHIN SPECS FROM FACTORY. CAUSED REAR TIRES TO WEAR OUT PREMATURELY. FRONT DISK BRAKE ROTORS AND BRAKES UNREPAIRABLE AT 11,000 MILES. CHEVROLET WOULD NOT COVER REPAIRS UNDER WARRANTY. *TR

[Document Search](#)

Check to Request Research. Submit below.

[Request Research](#)

[NHTSA.GOV](#) | [STOPIIMPAIREDDRIVING.ORG](#) | [TRAFFICSAFETYMARKETING.GOV](#) | [EMS.GOV](#)

[Policies](#) | [Terms of Use](#) | [USA.gov](#) | [FOIA](#) | [Privacy Policy](#) | [Accessibility](#) | [Careers](#) | [Site Map](#) | [Contact NHTSA](#)
 SE, West Building Washington DC 20590 USA 1.888.327.4236 TTY 1.800.424.9153

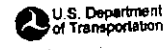

was700



Complaints - Search Results

12 Record(s) Displayed.

Report Date : July 22, 2012 at 08:12 AM
 Search Type : VEHICLE
 Year : 2007
 Make : CHEVROLET
 Model : IMPALA

Make : CHEVROLET Model : IMPALA Year : 2007
 Manufacturer : GENERAL MOTORS LLC
 Crash : No Fire : No Number of Injuries : 0
 ODI ID Number : 10458484 Number of Deaths : 0
 Date of Failure: May 7, 2012
 VIN : 2G1WD58C879...
 Component: WHEELS

Summary:
 2007 IMPALA SS THAT I HAVE OWNED SINCE APRIL 2011 AND BOUGHT WITH 24,000 MILES. THE PROBLEM IS WITH REAR TIRES ON THE CAR WEARING WITHIN ONE MONTH AFTER REPLACING. THE INSTALLATION OF TIRES IS FOLLOWED BY A PROFESSIONAL ALIGNMENT AND THE TIRES STILL WEAR DOWN TO THE WIRES. I HAVE BEEN THROUGH SEVERAL SETS OF TIRES AND ALIGNMENTS SINCE I PURCHASED THE CAR AND HAVE NOT YET FOUND A FIX OTHER THAN TIRES AND ALIGNMENT. DOCUMENTS HAVE INDICATED THAT THERE ARE BAD REAR SPINDLE RODS ON THE REAR OF THE CAR THAT GM HAS AKNOWLEDGED ARE PRESENT AND GM FAILED TO REPAIR THEM ON ALL 2007-2008 IMPALAS WITH THE EXCEPTION OF POLICE VEHICLES (APPROXIMATELY 23,000 POLICE DUTY CARS OUT OF 450,000+ AFFECTED). GM WILL NOT REPLACE THESE UNDER WARRANTY AND I CANNOT FIND A REPAIR FOR THE ISSUE. THE CAR WILL SLIP OUT OF ALIGNMENT WITHIN A FEW DAYS OR WEEKS AND CAUSE VERY DANGEROUS DRIVING CONDITIONS IF DRIVEN ON RAIN, SNOW OR ANY SLIPPERY SURFACE, CAUSING THE CAR TO SWAY IN THE REAR, HYDROPLANE AND EVEN LOSE CONTROL. THIS IS AN ENOURMOUS SAFETY HAZARD FOR IMPALA OWNERS AND ALSO OTHER DRIVERS THAT MAY HAVE AN ACCIDENT DUE TO THIS ISSUE. *JS

Make : CHEVROLET Model : IMPALA Year : 2007
 Manufacturer : GENERAL MOTORS LLC
 Crash : No Fire : No Number of Injuries : 0
 ODI ID Number : 10449019 Number of Deaths : 0
 Date of Failure: June 16, 2008
 VIN : 2G1WU58R479...
 Component: WHEELS

Summary:
 I NOTICED THINGS ABOUT MY CAR BUT IGNORED THEM BECAUSE I THOUGHT, THIS IS A BRAND NEW CAR AND IT SHOULDN'T HAVE ANY ISSUES. FROM THE VERY BEGINNING I WOULD NOTICE THAT MY CAR WOULD SLIDE A LOT WHEN THERE WAS SNOW/ICE/RAIN ON THE GROUND. AS IF IT WASN'T SITTING ON THE GROUND PROPERLY. I WOULD LOOK AT IT FROM THE REAR AT A DISTANCE AND IT ALWAYS SEEMED TO SLANT/DROOP AT AN ANGLE. ABOUT A YEAR AND HALF OF OWNERSHIP WHILE GETTING MY OIL CHANGED A SERVICE TECH FROM AN AUTHORIZED CHEVROLET DEALER INFORMED ME THAT I HAD EXCESSIVE TIRE WEAR AND STATED THAT I NEEDED ALL NEW TIRES. NOTE HE NEVER STATED THAT I NEEDED A WHEEL ALIGNMENT OR THAT THERE WAS A POSSIBLE RECALL NOTICE THAT WE COULD FIX WHILE YOUR CAR IS STILL UNDER. HE JUST WANTED TO SELL ME TIRES. FROM DOING MY RESEARCH IT LOOKS LIKE I AM NOT ALONE WITH THE ISSUE OF EXCESSIVE TIRE WEAR. LOOKS LIKE GM IS ALSO AWARE OF THIS ISSUE. THERE IS A GM BULLETIN 08032 BUT GM ONLY STATES THAT GOVERNMENT CARS ARE AFFECTED. I KNOW OF SEVERAL PEOPLE THAT WORK ON GM ASSEMBLY LINES AND THEY WILL STATE THAT THERE IS NO DIFFERENCE. SO WHY HAS THERE NOT BEEN A RECALL ON THIS ISSUE. THIS IS VERY DANGEROUS FOR GM TO KNOWING KNOW THAT SOMETHING IS NOT CORRECT ON THESE CARS AND THEY ARE REFUSING TO DO ANYTHING ABOUT IT. HOW MANY LIVES HAVE BEEN LOST OR HAVE TO BE LOST FOR GM TO CALL A RECALL AND FIX THE ISSUE ON THESE CARS. UPDATE 2/22/2012: I HAVE GOTTEN THE "NEEDED" "SPECIAL" WHEEL ALIGNMENT BUT AM STILL CONSTANTLY REPLACING TIRES THAT HAVE BEEN ON MY CAR NOT EVEN A YEAR. WILL NEVER BUY A CHEVY AGAIN. NOT REPUTABLE AND DOING THE RIGHT THING WHICH IS TO CORRECTLY FIX OVER 400,000 CARS. *TR

Make : CHEVROLET Model : IMPALA Year : 2007
 Manufacturer : GENERAL MOTORS LLC
 Crash : No Fire : No Number of Injuries : 0

ODI ID Number : 10436526 **Number of Deaths:** 0

Date of Failure: November 21, 2011

VIN : 2G1WT58K979...

Component: WHEELS

Summary:

MY 2007 CHEVROLET IMPALA WAS RECENTLY IN CHEVROLET SHOP FOR 30,000 MILES MAINTENANCE. I WAS SHOCKED WHEN TOLD I NEEDED TIRES. I AM THE ORIGINAL OWNER AND DRIVE TO AND FROM WORK AND AN OCCASIONAL WEEKEND TRIP. I HAVE MY TIRES ROTATED EVERY 10,000 MILES. WHAT GIVES? *TR

Make : CHEVROLET **Model :** IMPALA **Year :** 2007

Manufacturer : GENERAL MOTORS LLC

Crash : No **Fire :** No **Number of Injuries:** 0

ODI ID Number : 10436493 **Number of Deaths:** 0

Date of Failure: August 12, 2008

VIN : Not Available

Component: WHEELS

Summary:

TIRES COMPLETELY WORN AT 23,000 MILES DEALER SAID BECAUSE NOT ROTATED PROPERLY (\$500 FOR NEW TIRE) ROTATED EVERY 7000 MILES THEY FAILED AT 61,209 MILES PUT ON FOUR NEW TIRES (3RD SET ANOTHER \$470) AND ROTATED EVERY 5000 DEALER SAID POOR CHOICE OF TIRES INSTALLED GOODYEAR PREMIUM TIRE NEXT SET WENT IN 20000 MILES WHEEL ALIGNMENT DONE EVERY YEAR NO ADJUSTMENTS NEEDED, LAST SET OF TIRES NOW WORN AT MILEAGE 83,300. I HAVE HAD 15 NEW CARS DURING MY LIFETIME AND NEVER HAVE I ENCOUNTERED THE PREMATURE WEAR I HAVE ON THIS IMPALA. DRIVING ALL HIGHWAY MILES I DO NOT SPEED OR CORNER FAST I ROTATE TIRES CHECK AIR PRESSURE IN ADDITION TO TPMS SYSTEM WHY AM I SEEING TIRE FAILURE ON THREE DIFFERENT BRANDS OF PREMIUM TIRE? *TR

Make : CHEVROLET **Model :** IMPALA **Year :** 2007

Manufacturer : GENERAL MOTORS LLC

Crash : No **Fire :** No **Number of Injuries:** 0

ODI ID Number : 10412468 **Number of Deaths:** 0

Date of Failure: May 6, 2008

VIN : 2G1WT58K479...

Component: WHEELS

Summary:

I HAD A COMPANY CAR, 2007 IMPALA THAT WAS WEARING THE TIRES UNEVENLY. I WENT THROUGH SEVERAL SETS OF TIRES AS A RESULT OF THIS PROBLEM. I THOUGHT THAT THE TIRE DEALERSHIP WAS NOT DOING A GOOD JOB HOWEVER JUST NOTICED THAT THERE IS LAWSUIT STATING THERE WAS A PROBLEM WITH THE SPINDLES. MY FATHER, NOW OWNS THE VEHICLE. AND WANT TO BRING THIS TO THE NHTSA ATTENTION AS WELL AS TO BE NOTIFIED OF A RECALL AS MY FATHER IS NOW DRIVING THE VEHICLE.

Make : CHEVROLET **Model :** IMPALA **Year :** 2007

Manufacturer : GENERAL MOTORS LLC

Crash : No **Fire :** No **Number of Injuries:** 0

ODI ID Number : 10392576 **Number of Deaths:** 0

Date of Failure: November 19, 2010

VIN : 2G1WT58N479...

Component: WHEELS

Summary:

TL*THE CONTACT OWNS A 2007 CHEVROLET IMPALA. THE CONTACT STATED THAT THE ALL FOUR TIRES WERE WORN DOWN TO THE METAL AFTER A SHORT PERIOD OF TIME. THE TIRES WERE REPLACED. THE VEHICLE WAS TAKEN TO AN AUTHORIZED DEALER WHO STATED THAT THEY WERE UNAWARE OF THE PROBLEM. A LOCAL MECHANIC STATED THAT THE WHEELS WERE THE CAUSE OF THE TIRE WEAR. THE CONTACT CALLED THE MANUFACTURER WHO STATED THAT THEY WOULD LOOK INTO THE PROBLEM. ADDITIONALLY, THERE WAS CORROSION ON THE EMISSIONS SOLENOID WHICH SHE WAS ALERTED TO WHEN THE CHECK ENGINE LIGHT ILLUMINATED. THE VEHICLE WAS TAKEN TO THE DEALER WHO STATED THAT EITHER CARBON WAS STUCK IN THE VALVE OR THE SOLENOID WAS FULL OF WATER. THE VEHICLE WAS REPAIRED. ALSO, THE CABLE TO THE BATTERY WAS CORRODED. TWO MECHANICS INSPECTED THE VEHICLE AND STATED THAT THE FAILURE WAS NOT CAUSED BY NORMAL WEAR AND TEAR. THE VEHICLE WAS REPAIRED. THE CURRENT MILEAGE WAS APPROXIMATELY 73,000. THE FAILURE MILEAGE WAS APPROXIMATELY 66,000.

Make : CHEVROLET **Model :** IMPALA **Year :** 2007

Manufacturer : GENERAL MOTORS LLC**Crash :** No**Fire :** No**Number of Injuries :** 0**ODI ID Number :** 10341592**Number of Deaths :** 0**Date of Failure:** June 30, 2010**VIN :** 2G1WU58R979...**Component:** WHEELS**Summary:**

THIS INVOLVES A CONTINUED REAR TIRE ISSUE WITH MY 2007 CHEVY IMPALA LTZ THAT HAS NOT BEEN RESOLVED DESPITE ENCOUNTERS WITH DEALERS & NATIONAL TIRE ALIGNMENT SPECIALISTS 12/06: PURCHASED CAR NEW, CAME WITH GOODYEAR EAGLE LS2 RADIALS. 3/08: ONE TIRE BLEW IN CHARLOTTE, NC. AT JUST TIRES, THEY POINTED OUT THAT BOTH REAR TIRES INCLUDING THE ONE THAT BLEW HAD SIGNIFICANT SIGNS OF WEAR, REPLACED BOTH WITH LS2 RADIALS. THE PROBLEM WAS CHALKED UP TO ALIGNMENT ISSUES THAT COULDN'T STARTED FROM THE FACTORY. 11/08: AFTER MORE INCIDENTS OF LOW REAR TIRE PRESSURE, TOOK CAR INTO LOCAL JUST TIRES. TIRED OF CONTINUED ISSUES, I DECIDE TO GET TOP OF THE LINE TIRES FROM THEM (GOODYEAR ASSURANCE TRIPLETRIED) FOR JUST UNDER \$900. 9/09: TIRE KEPT LOSING PRESSURE. TOOK CAR INTO LOCAL JUST TIRES. TOLD TIRES WERE NOT ONLY ONCE AGAIN OUT OF ALIGNMENT, BUT REAR TIRES AGAIN NEEDED REPLACEMENT (IN A MANNER NOT COVERED BY ROAD HAZARD PLAN) FOR \$507 WITH TREADS SEVERELY WORN DOWN. THE PROBLEM WAS AGAIN CHALKED UP TO ALIGNMENT ISSUES, THOUGH THEY ALIGNED THE TIRES IN 11/08. 6/10: RANDOMLY CHECK TREADS ON MY TOP-LINE TIRES. COMPLETELY FINE IN FRONT, BUT WORN DOWN CONSIDERABLY ON BOTH REAR TIRES. I DRIVE ONLY CITY STREETS & HAD DRIVEN LESS THAN 12,000 MILES SINCE BUYING 4 NEW TIRES. RESEARCH UNCOVERS A PLETHORA OF REAR-END ALIGNMENT ISSUES ON 2007 CHEVY IMPALAS, INCLUDING A SPECIFIC IDENTIFIED ISSUE: [HTTP://FLEETLEADER.PHH.COM/RECALLS/2008/RECALLS.JULY2008.PDF](http://fleetleader.phh.com/recalls/2008/recalls.july2008.pdf) CUSTOMER SATISFACTION PROGRAM #08032 - UNEVEN POLICE CAR REAR TIRE WEAR OBVIOUSLY, THIS EXTENDED TO COMMERCIAL IMPALAS & EXPLAINS WHAT'S BEEN HAPPENING. WHEN CALLING PALLONE CHEVROLET, THE SERVICE REP FLATLY DISMISSES THE TALK OF THE POLICE RECALL, SAYING THAT THE SPINDLE ROD PARTS INVOLVED ARE COMPLETELY DIFFERENT. (LATER CHECKING INDICATES THE PARTS ARE EXACTLY THE SAME ON BOTH THE POLICE AND COMMERCIAL VEHICLES.) ILM TOLD THAT THE ONLY WAY THEY CAN HELP IS TO CHECK ALIGNMENT, AS IF NOTHING ELSE COULD BE CAUSING THE PROBLEM. *TR

Make : CHEVROLET**Model :** IMPALA**Year :** 2007**Manufacturer :** GENERAL MOTORS LLC**Crash :** No**Fire :** No**Number of Injuries :** 0**ODI ID Number :** 10294195**Number of Deaths :** 0**Date of Failure:** November 30, 2009**VIN :** 2G1WT55N079...**Component:** WHEELS**Summary:**

I AM NOW BUYING THE 3RD SET OF REAR TIRES IN LESS THAN A YEAR. THE INSIDE TREAD WEARS DOWN TO THE WIRES EVERY 13-16,000 MILES. THE VIN ON MY CAR FALLS WITHIN THE VIN'S LISTED ON GM TSB 8032, HOWEVER THIS CAR IS NOT A POLICE CAR. GM STATES THAT I MUST BE HITTING A POTHOLE CAUSING ALIGNMENT PROBLEMS. I MUST BE HITTING THE SAME POTHOLE AT THE SAME MILEAGE ALL 3 TIMES AND IT ONLY AFFECTS THE REAR TIRES. THERE IS EXTENSIVE ANECDOTAL REFERENCES TO THIS PROBLEM ON NUMEROUS CAR COMPLAINT WEBSITES, INCLUDING NHTSA. SOMEONE IS GOING TO GET SERIOUSLY HURT IF GM IS ALLOWED TO IGNORE THIS PROBLEM. GM'S ONLY SOLUTION IS TO SELL ME ALIGNMENTS AND TIRES SINCE IT IS "MY FAULT" AND EVEN THOUGH THE PROBLEM IS IDENTICAL TO THE ISSUE NOTED BY GM IN TSB 8032, IT CAN'T POSSIBLY BE RELATED SINCE THE OTHER IDENTICAL PROBLEM ONLY HAPPENS ON POLICE AND GOVERNMENT CARS TO WHICH GM SELLS A LOT OF CARS. THE EVERYDAY INDIVIDUAL DOES NOT HAVE THE COMPLAINING POWER OF A LARGE BULK PURCHASER. *TR

Make : CHEVROLET**Model :** IMPALA**Year :** 2007**Manufacturer :** GENERAL MOTORS LLC**Crash :** No**Fire :** No**Number of Injuries :** 0**ODI ID Number :** 10283778**Number of Deaths :** 0**Date of Failure:** September 11, 2009**VIN :** 2G1WT58K479...**Component:** WHEELS**Summary:**

TIRES WEARING ON INSIDE TREAD OF ALL FOUR TIRES. *TR

Make : CHEVROLET**Model :** IMPALA**Year :** 2007**Manufacturer :** GENERAL MOTORS LLC**Crash :** No**Fire :** No**Number of Injuries :** 0**ODI ID Number :** 10282425**Number of Deaths :** 0**Date of Failure:** August 28, 2009

VIN : 2G1WT55N979...

Component: WHEELS

Summary:

ALL 4 WHEELS ARE OUT OF ALIGNMENT CAUSING EXCESSIVE WEAR ON THE INSIDE OF ALL 4 TIRES. I BOUGHT THE VEHICLE 2 YEARS AGO AND IT HAD ONLY 14000 MILES. I BELIEVE IT WAS A RENTAL VEHICLE. I NOW HAVE TO REPLACE ALL 4 TIRES AND GET A 4 WHEEL ALIGNMENT DONE. I BELIEVE THE PROBLEM WAS CAUSED BY THE ORIGINAL MANUFACTURER (POOR QUALITY CONTROL). THE DEALER SAID IT WAS CAUSED BY THE BRAND OF TIRE ON THE VEHICLE WHICH IS NONSENSE. *TR

Make : CHEVROLET

Model : IMPALA

Year : 2007

Manufacturer : GENERAL MOTORS LLC

Crash : No

Fire : No

Number of Injuries: 0

ODI ID Number : 10286826

Number of Deaths: 0

Date of Failure: December 16, 2008

VIN : 2G1WC58R179...

Component: WHEELS

Summary:

TL*THE CONTACT OWNS A 2007 CHEVROLET IMPALA. THE CONTACT NOTICED THAT THE REAR WHEELS HAD EXCESSIVE TREAD WEAR. HE TOOK THE VEHICLE TO THE DEALER ON NUMEROUS OCCASIONS AND THEY REPLACED THREE REAR SETS OF TIRES AND PERFORMED THREE ALIGNMENTS. HE CALLED THE MANUFACTURER IN REFERENCE TO TSB NUMBERS 10026504 AND 10026484 (WHEELS) AND WAS INFORMED THAT THEY WOULD ONLY REPLACE THE COMPONENT ON THE POLICE AND STATE VEHICLES. THE TIRE INFORMATION WAS UNKNOWN. THE FAILURE MILEAGE WAS 23,000 AND CURRENT MILEAGE WAS 26,000.

Make : CHEVRQLET

Model : IMPALA

Year : 2007

Manufacturer : GENERAL MOTORS LLC

Crash : No

Fire : No

Number of Injuries: 0

ODI ID Number : 10256199

Number of Deaths: 0

Date of Failure: December 6, 2007

VIN : Not Available

Component: WHEELS

Summary:

WHEN IT RAINS THE FRONT WHEEL WELLS ARE EXTREMELY LOUD. IT OCCURRED EVERYTIME IT RAINS ONCE THE TIRES WERE WORN DOWN. I WENT BACK TO THE PURCHASE PLACE AND HAD THEIR MECHANICS LOOK AT IT AND THEN I TOOK IT TO A DIFFERENT MECHANIC NEITHER OF WHICH FOUND ANYTHING. I HAD TO REPLACE THE FRONT TIRES AFTER 6 MONTHS OF OWNING THE VEHICLE AND THE REAR TIRES 3 MONTHS LATER. *TR

1200 New Jersey Avenue, SE, West Building Washington DC 20590 USA
1.888.327.4236 TTY 1.800.424.9153





Complaints - Search Results

2 Record(s) Displayed.

Report Date : July 22, 2012 at 04:18 PM
 Search Type : VEHICLE
 Year : 2007
 Make : CHEVROLET
 Model : IMPALA

Make : CHEVROLET Model : IMPALA Year : 2007
 Manufacturer : GENERAL MOTORS LLC
 Crash : No Fire : No Number of Injuries : 0
 ODI ID Number : 10310699 Number of Deaths : 0
 Date of Failure : February 10, 2010
 VIN : 2G1WC58RX79...
 Component: STRUCTURE:BODY

Summary:
 I DID NOT REALIZE SUCH A WEBSITE EXISTED. I HAVE PURCHASED MANY NEW VEHICLES AND HAVE ALWAYS BEEN HAPPY UNTIL I PURCHASED MY 2007 IMPALA BRAND NEW WITH 27 MILES. I STARTED LOOKING ON THE INTERNET DUE TO "STEERING" PROBLEM AND FOUND THIS WEBSITE. YOU CAN BE DRIVING DOWN THE ROAD AND THE STEERING WHEEL WILL LOCK UP AND NOT MOVE FOR SEVERAL SECONDS. IT WOULD BE VERY EASY TO HAVE AN ACCIDENT YOU NEED THE WHEELS TO TURN, BUT THE WHEEL WANT MOVE. I THINK MY HUSBAND THOUGHT I WAS CRAZY UNTIL HE HAPPEN TO BE WITH ME THE OTHER DAY AND WITNESS THIS. I HAVE NOTICED THAT ALL 5 TIMES THIS HAS HAPPENED IT HAS BEEN RAINING OUT. THE 1ST 2 TIMES WERE PROBABLY A YEAR AGO, BUT IT HAS HAPPENED 3 TIMES IN THE LAST 2 MONTHS. I HAVE ALSO HAD THE TIRE ISSUE, DID NOT THINK ABOUT IT BEING THE CAR, BUT I HAVE HAD 3 SETS OF BRAND NEW TIRES ON THIS VEHICLE. SAME PROBLEM SOMEONE ELSE MENTIONED THE REAR TIRES WEAR COMPLETELY OUT ON THE INSIDE. I HAD WIRES HANGING OUT ON 1 YEAR OLD TIRES. I DO NOT FEEL SAFE AT ALL IN THIS VEHICLE AND CAN'T IMAGINE ANYONE WANTING TO DRIVE A VEHICLE THAT THE STEERING LOCKS UP. I HAVE 2 PRECIOUS CHILDREN AND AM NOT HAPPY WITH THIS. I STILL OWE A TREMENDOUS AMOUNT ON THE VEHICLE SO I DON'T REALLY HAVE ANY OPTIONS BUT TO REPORT TO SOMEONE THAT MIGHT COULD HELP. THANKS! THE STRUCTURE- THE DOOR MOLDING JUST FELL OFF ON THE DRIVERS SIDE ONE DAY. *TR

Make : CHEVROLET Model : IMPALA Year : 2007
 Manufacturer : GENERAL MOTORS LLC
 Crash : No Fire : No Number of Injuries : 0
 ODI ID Number : 10182007 Number of Deaths : 0
 Date of Failure : December 20, 2006
 VIN : Not Available
 Component: STRUCTURE:BODY

Summary:
 TL* - THE CONTACT OWNS A 2007 CHEVROLET IMPALA LT, 3.9 L, V6, 4 DOOR. THE CUP HOLDER WAS NOT MADE PROPERLY WHICH COULD CAUSE SPILLAGE OF COLD/HOT ON A PERSON. THE MANUFACTURER STATED THAT THE CONTACT COULD NOT SPEAK TO THE ENGINEER THAT DESIGNED THE CUP HOLDER. HE THOUGHT IT WAS POSSIBLE THAT THEY MAY HAVE MADE A MISTAKE. THIS WAS A SAFETY PROBLEM AND HE EXPERIENCED THAT PROBLEM WITH A LIQUID SPILLING ON HIM. THE CURRENT AND FAILURE MILEAGE WAS 950. THE INCIDENT OCCURRED WHEN THE CONTACT WAS DRIVING AT 20 MPH AND MAKING A TURN. *AK

1200 New Jersey Avenue, SE, West Building Washington DC 20590 USA
 1.888.327.4236 TTY 1.800.424.9153





Complaints - Search Results

49 Record(s) Displayed.

Report Date : July 22, 2012 at 04:13 PM
 Search Type : VEHICLE
 Year : 2007
 Make : CHEVROLET
 Model : IMPALA

Make : CHEVROLET Model : IMPALA Year : 2007
 Manufacturer : GENERAL MOTORS LLC
 Crash : No Fire : No Number of Injuries: 0
 ODI ID Number : 10462873 Number of Deaths: 0
 Date of Failure: June 24, 2012
 VIN : Not Available
 Component: STEERING

Summary:

THIS CAR HAS LESS THAN 100K MILES AND CHEVY DEALERSHIPS REFUSE TO DIAGNOSE THE ISSUE WITH THE TRANSMISSIONS AND THERE ARE MULTIPLE COMPLAINTS ABOUT THIS ISSUE THIS CAR IS UNSAFE. THE ISSUE IS RANDOM JERKING OF THE TRANSMISSION UPON TAKING OFF IN TRAFFIC, AT LIGHT, OR FROM STAND STILL HAS CAUSED: (A) MY WHEELS TO SPIN, (B) THE CAR TO PULL INTO THE NEXT LANE, (C) ALMOST REAR-END COLLISION WITH CAR IN FRONT, AND (D) SUDDEN RAPID ACCELERATION IN TRAFFIC. THE CAR I ALMOST REAR-ENDED WAS A 2007 CHEVY POLICE IMPALA THE OFFICER EXITED HIS CAR ASKED WAS THERE A PROBLEM I TOLD HIM ABOUT THE TRANSMISSION ISSUE AND HE STATED "YEA MINE DOES THAT TOO THIS CAR ISN'T A SAFE ONE" THIS NEED TO BE ADDRESSED NATIONALLY. *TR

Make : CHEVROLET Model : IMPALA Year : 2007
 Manufacturer : GENERAL MOTORS LLC
 Crash : No Fire : No Number of Injuries: 0
 ODI ID Number : 10458484 Number of Deaths: 0
 Date of Failure: Mey 7, 2012
 VIN : 2G1WD58C879...
 Component: STEERING

Summary:

2007 IMPALA SS THAT I HAVE OWNED SINCE APRIL 2011 AND BOUGHT WITH 24,000 MILES. THE PROBLEM IS WITH REAR TIRES ON THE CAR WEARING WITHIN ONE MONTH AFTER REPLACING, THE INSTALLATION OF TIRES IS FOLLOWED BY A PROFESSIONAL ALIGNMENT AND THE TIRES STILL WEAR DOWN TO THE WIRES. I HAVE BEEN THROUGH SEVERAL SETS OF TIRES AND ALIGNMENTS SINCE I PURCHASED THE CAR AND HAVE NOT YET FOUND A FIX OTHER THAN TIRES AND ALIGNMENT. DOCUMENTS HAVE INDICATED THAT THERE ARE BAD REAR SPINDLE RODS ON THE REAR OF THE CAR THAT GM HAS ACKNOWLEDGED ARE PRESENT AND GM FAILED TO REPAIR THEM ON ALL 2007-2008 IMPALAS WITH THE EXCEPTION OF POLICE VEHICLES (APPROXIMATELY 23,000 POLICE DUTY CARS OUT OF 450,000+ AFFECTED). GM WILL NOT REPLACE THESE UNDER WARRANTY AND I CANNOT FIND A REPAIR FOR THE ISSUE. THE CAR WILL SLIP OUT OF ALIGNMENT WITHIN A FEW DAYS OR WEEKS AND CAUSE VERY DANGEROUS DRIVING CONDITIONS IF DRIVEN ON RAIN, SNOW OR ANY SLIPPERY SURFACE, CAUSING THE CAR TO SWAY IN THE REAR, HYDROPLANE AND EVEN LOSE CONTROL. THIS IS AN ENORMOUS SAFETY HAZARD FOR IMPALA OWNERS AND ALSO OTHER DRIVERS THAT MAY HAVE AN ACCIDENT DUE TO THIS ISSUE. *JS

Make : CHEVROLET Model : IMPALA Year : 2007
 Manufacturer : GENERAL MOTORS LLC
 Crash : No Fire : No Number of Injuries: 0
 ODI ID Number : 10455222 Number of Deaths: 0
 Date of Failure: March 28, 2012
 VIN : 2G1WU58R179...
 Component: STEERING

Summary:

TL* THE CONTACT OWNS A 2007 CHEVROLET IMPALA. THE CONTACT STATED THAT WHILE DRIVING 50 MPH, THE POWER STEERING FAILED. THE CONTACT ALSO STATED THAT IT BECAME VERY DIFFICULT TO STEER TO THE POINT THAT HE LOST CONTROL OF THE VEHICLE. THE VEHICLE WAS TAKEN TO THE

DEALER, WHO DIAGNOSED THAT THE INTERMEDIATE STEERING SHAFT WAS DEFECTIVE AND NEEDED TO BE REPLACED. THE MANUFACTURER WAS MADE AWARE OF THE FAILURE AND THEY OFFERED NO ASSISTANCE BECAUSE THE VEHICLE WAS NO LONGER UNDER WARRANTY. THE VEHICLE WAS NOT REPAIRED. THE FAILURE AND CURRENT MILEAGES WERE 85,000.

Make : CHEVROLET **Model :** IMPALA **Year :** 2007
Manufacturer : GENERAL MOTORS LLC
Crash : No **Fire :** No **Number of Injuries :** 0
ODI ID Number : 10454126 **Number of Deaths :** 0
Date of Failure: February 16, 2012
VIN : Not Available
Component: STEERING

Summary:

LETTER FROM CONGRESSMAN CARTER ON BEHALF OF CONSTITUENT RE ISSUE OF GM'S LIABILITY FOR DEFECTIVE PARTS ON CARS THEY MANUFACTURED *TGW AS A RESULT OF A DESIGN FLAW AND DEFECTIVE PARTS, THE TRI-COILED REAR SPRINGS, TRAILING ARMS AND SPINDLE RODS ARE CAUSING PREMATURE WEAR OF REAR TIRES. GM RECALLED VEHICLES USED IN POLICE WORK; BUT NOT THE GENERAL PUBLIC. GM SAYS THEY ARE NOT LIABLE, BECAUSE ITS 2009 BANKRUPTCY AND SUBSEQUENT REORGANIZATION SHIELDS THEM FROM LIABILITY OVER THE ALLEGED DESIGN FLAWS. *TR UPDATED 04/010/12

Make : CHEVRDLET **Model :** IMPALA **Year :** 2007
Manufacturer : GENERAL MOTORS LLC
Crash : No **Fire :** No **Number of Injuries :** 0
ODI ID Number : 10452733 **Number of Deaths :** 0
Date of Failure: March 19, 2012
VIN : 2G1WU58R179...
Component: STEERING

Summary:

THE INTERMEDIATE STEERING SHAFT IS FAULTY ON MY 2007 CHEVROLET IMPALA LTZ. IT CURRENTLY HAS 85176 MILES AS IT IS IN A SHOP. THIS IS THE 10TH TIME ME OR ONE OF MY FRIENDS HAS HAD THIS PROBLEM. IT HAS OCCURRED MULTIPLE TIMES ON THE FOLLOWING VEHICLES: 2009 PONTIAC G6 SPORT 2 (MINE) 37,900 MILES, AND WAS BOUGHT NEW. 2008 PONTIAC G6 SPORT 2 (ROOMMATES) CAR WAS PURCHASED USED AND HAS 50,076 MILES ON IT. 2009 CHEVROLET IMPALA LT (ROOMMATES MOMS) 60,000 MILES THE CAR HAS BEEN DRIVEN, IT WAS PURCHASED NEW. THIS IS ONLY ONE OF MANY ISSUES WE HAVE HAD WITH THESE THREE CARS. THE OTHER MAJOR ONE IS THAT THE HEAD GASKETS ON THESE CARS DO NOT HOLD UP, AND GM IS DOING NOTHING ABOUT IT. MINE IS IN THE SHOP NOW ALSO FOR A HEAD GASKET (07 IMPALA). WHY IS THERE NO HELP FOR GM CAR OWNERS? GM IS NOT HELPING! JUST SCREWING US OUT OF MONEY! *TR

Make : CHEVROLET **Model :** IMPALA **Year :** 2007
Manufacturer : GENERAL MOTORS LLC
Crash : No **Fire :** No **Number of Injuries :** 0
ODI ID Number : 10449279 **Number of Deaths :** 0
Date of Failure: February 24, 2012
VIN : 2G1WT58K379...
Component: STEERING

Summary:

I HAVE A 2007 CHEVROLET IMPALA FOR MY WIFE TO DRIVE WITH MY TWO CHILDREN. THE POWER STEERING FAILS INTERMITTENTLY IN THE RAIN. THIS IS EXTREMELY DANGEROUS BECAUSE THE POWER ASSIST COMES AND GOES QUICKLY CAUSING THE DRIVER TO JERK THE WHEEL WHEN THE PWER ASSIST RETURNS. I REPLACED THE SERPENTINE BELT TWO MONTHS AGO FOR THE SAME ISSUE AND IT WAS FINE FOR A WHILE. I HAVE OVER 30 YEARS OF AUTOMOTIVE EXPERIENCE AND I HAVE EXPERIENCED THIS WHILE DRIVING THIS VEHICLE AND IT IS DANGEROUS. THERE IS CLEARLY A MANUFACTURE DEFECT WITH THE POWER ASSIST BELT, TENSIONER OR A PULLEY. THIS IS NOT THE OTHER CONCERN WITH THE CLUNKING INTERMEDIATE SHAFT. *TR

Make : CHEVROLET **Model :** iMPALA **Year :** 2007
Manufacturer : GENERAL MOTORS LLC
Crash : No **Fire :** No **Number of Injuries :** 0
ODI ID Number : 10441993 **Number of Deaths :** 0
Date of Failure: January 1, 2012
VIN : Not Available
Component: STEERING

Summary:

RECENTLY BOUGHT 2007 CHEVY IMPALA FOR SON. THIS CAR CANNOT STAY ON THE ROAD IN WET/SNOW CONDITIONS. IT FISHTAILS AND IS SCARY TO DRIVE. I'VE LIVED IN WISCONSIN ALL MY LIFE AND DROVE MANY DIFFERENT CARS BUT NEVER A CAR AS DANGEROUS AS THIS. *TR

Make : CHEVROLET **Model :** IMPALA **Year :** 2007
Manufacturer : GENERAL MOTORS LLC
Crash : No **Fire :** No **Number of Injuries :** 0
ODI ID Number : 10437945 **Number of Deaths :** 0
Date of Failure: April 14, 2010
VIN : 2G1WC58R679...
Component: STEERING

Summary:

TL* THE CONTACT OWNS A 2007 CHEVROLET IMPALA. THE CONTACT STATED THE REAR END OF THE VEHICLE WAS OUT OF ALIGNMENT TWICE EACH TIME THE REAR TIRES HAD TO BE REPLACED. THE MANUFACTURER STATED IT WAS NOT A KNOWN FAILURE. THE DEALER STATED THE MANUFACTURER WAS REPAIRING POLICE VEHICLES WITH THE IDENTICAL FAILURE. THE CONTACT WAS CONCERNED ABOUT THE SAFETY DEFECT. THE FAILURE MILEAGE WAS 43,000 AND THE CURRENT MILEAGE WAS 72,000.UPDATED 12/03/12 *BF

Make : CHEVROLET **Model :** IMPALA **Year :** 2007
Manufacturer : GENERAL MOTORS LLC
Crash : No **Fire :** No **Number of Injuries :** 0
ODI ID Number : 10435963 **Number of Deaths :** 0
Date of Failure: November 14, 2011
VIN : 2G1WC58R379...
Component: STEERING

Summary:

I HAD NOTICED A NOISE IN STEERING RECENTLY, WENT TO DEALER AND WAS TOLD THAT THERE MUST BE DUST AROUND THE STEERING COLUMN. HAD BEEN ON VACATION AND NOT DRIVING CAR FOR A MONTH OR MORE, THEN 11-14-11 IT WAS SOMETHING VERY NOTICEABLE AND I DROVE DIRECTLY TO DEALERSHIP TO BE CHECKED. THEY CHARGED \$98.00 TO DIAGNOSE THE PROBLEM AND REPLACED STEERING SHAFT #25937478 SHAFT (06524-C). MY TOTAL BILL WAS \$312.86. IS THIS ANY PART OF MY WARRANTY COVERAGE????? *TR

Make : CHEVROLET **Model :** IMPALA **Year :** 2007
Manufacturer : GENERAL MOTORS LLC
Crash : No **Fire :** No **Number of Injuries :** 0
ODI ID Number : 10420937 **Number of Deaths :** 0
Date of Failure: February 14, 2006
VIN : Not Available
Component: STEERING

Summary:

TL* THE CONTACT OWNS A 2007 CHEVROLET IMPALA LT. WHILE DRIVING APPROXIMATELY 40 MPH, THE REAR PASSENGER TIRE EXPLODED. THE CONTACT DROVE TO THE SIDE OF THE ROAD AND THE ROADSIDE ASSISTANCE REPLACED THE TIRE WITH A SPARE TIRE. THE VEHICLE WAS TAKEN TO A TIRE CENTER WHERE THEY INFORMED THE CONTACT THAT THE SEVERE TIRE WEAR WAS CONTRIBUTED TO MISALIGNMENT. THE TECHNICIAN REPLACED THE DEFECTIVE TIRE AND AN ALIGNMENT WAS PERFORMED. ON A SEPARATE OCCASION THE FAILURE RECURRED WITH THE IDENTICAL TIRE. THE DEFECTIVE TIRE WAS REPLACED WITH A NEW TIRE. A FOUR WHEEL ALIGNMENT WAS PERFORMED ON THE VEHICLE THREE DIFFERENT TIMES AND THE FAILURE CONTINUED TO OCCUR. THE REAR DRIVER, FRONT DRIVER AND PASSENGER SIDE TIRES HAD BEEN REPLACED AS A RESULT TO THE PREMATURE TIRE WEAR. THE MANUFACTURER WAS NOTIFIED OF THE CONSISTENT FAILURE. THE DEALER WAS UNABLE TO DETERMINE THE CAUSE OF FAILURE. THE APPROXIMATE FAILURE MILEAGE WAS 12,000. THE VIN WAS UNAVAILABLE.

Make : CHEVROLET **Model :** IMPALA **Year :** 2007
Manufacturer : GENERAL MOTORS LLC
Crash : No **Fire :** No **Number of Injuries :** 0
ODI ID Number : 10416909 **Number of Deaths :** 0
Date of Failure: December 21, 2010
VIN : Not Available
Component: STEERING

Summary:

TL* THE CONTACT OWNS A 2007 CHEVROLET IMPALA. THE CONTACT STATED WHEN THE ROAD CONDITIONS WERE WET, THE VEHICLE WOULD SLIDE AND HE WAS UNABLE TO CONTROL THE VEHICLE. BOTH THE DEALER AND MANUFACTURER WERE NOTIFIED; HOWEVER, DID NOT OFFER ANY ASSISTANCE. NO REPAIRS WERE PERFORMED. THE CURRENT MILEAGE WAS 62,000. THE FAILURE MILEAGE WAS 42,000. THE VIN WAS UNAVAILABLE.

Make : CHEVROLET **Model :** IMPALA **Year :** 2007
Manufacturer : GENERAL MOTORS LLC
Crash : No **Fire :** No **Number of Injuries:** 0
ODI ID Number : 10412411 **Number of Deaths:** 0
Date of Failure: July 15, 2008
VIN : 2G1WT55N079...

Component: STEERING

Summary:

TL* THE CONTACT OWNS A 2007 CHEVROLET IMPALA. THE CONTACT STATED THAT ALL FOUR TIRES WERE CONSISTENTLY WEARING FROM THE INSIDE AND WERE CONSTANTLY IN NEED OF REPLACEMENT AND AN ALIGNMENT. THE DEALER WAS CONTACTED WHO OFFERED NO ASSISTANCE FOR THE REPAIRS. THE MANUFACTURER WAS CONTACTED ABOUT THE FAILURE BUT OFFERED NO ASSISTANCE. THE FAILURE MILEAGE WAS 71,209. UPDATED 08/15/11 *BF UPDATED 08/24/11. *JB

Make : CHEVROLET **Model :** IMPALA **Year :** 2007
Manufacturer : GENERAL MOTORS LLC
Crash : No **Fire :** No **Number of Injuries:** 0
ODI ID Number : 10412265 **Number of Deaths:** 0
Date of Failure: July 1, 2008
VIN : 2G1WT55N479...

Component: STEERING

Summary:

TL* THE CONTACT OWNS A 2007 CHEVROLET IMPALA. THE CONTACT STATED THAT THE VEHICLE WAS TAKEN TO AN AUTHORIZED DEALER ON TWO OCCASIONS TO BE REALIGNED. THE VEHICLE WAS ALSO TAKEN TO HAVE THE TIRES REPLACED ON ONE OCCASION DUE TO UNEVEN TREAD WEAR. THE VEHICLE WAS IN THE PROCESS OF BEING TAKEN BACK TO HAVE THE TIRES REPLACED FOR A SECOND TIME DUE TO UNEVEN TREAD WEAR. THE FAILURE MILEAGE WAS 20,000 AND THE CURRENT MILEAGE WAS 50,000.

Make : CHEVROLET **Model :** IMPALA **Year :** 2007
Manufacturer : GENERAL MOTORS LLC
Crash : No **Fire :** No **Number of Injuries:** 0
ODI ID Number : 10410749 **Number of Deaths:** 0
Date of Failure: October 13, 2009
VIN : 2G1WC58R979...

Component: STEERING

Summary:

TL* THE CONTACT OWNS A 2007 CHEVROLET IMPALA. WHILE DRIVING APPROXIMATELY 65 MPH, THE VEHICLE DRIFTED INTO THE LEFT LANE WITHOUT INTENT. THE CONTACT IMMEDIATELY TURNED THE STEERING WHEEL TOWARDS THE RIGHT DIRECTION IN ORDER FOR THE VEHICLE TO DRIVE STRAIGHT. THE VEHICLE WAS TAKEN TO AN AUTHORIZED DEALER WHERE THE FOUR TIRES WERE ROTATED, AND THE FAILURE CONTINUED TO OCCUR. THE CONTACT PLANNED TO TAKE THE VEHICLE BACK TO THE DEALER FOR DIAGNOSIS AND REPAIR. THE MANUFACTURER WAS NOTIFIED OF THE DEFECT. THE FAILURE MILEAGE WAS UNAVAILABLE.

Make : CHEVROLET **Model :** IMPALA **Year :** 2007
Manufacturer : GENERAL MOTORS LLC
Crash : No **Fire :** No **Number of Injuries:** 0
ODI ID Number : 10410710 **Number of Deaths:** 0
Date of Failure: January 11, 2011
VIN : 2G1WU58R579...

Component: STEERING

Summary:

VEHICLE PERFORMED POORLY OVER 35 MPH ON HIGHWAY WITH THE REAR OF THE VEHICLE SWAYING EXCESSIVELY DURING SNOWY OR WET CONDITIONS. THE TIRES ON THE BACK OF THE VEHICLE WORE PREMATURELY ON THE INSIDE . I PURCHASED FOUR SETS OF NEW BACK TIRES IN A SPAN OF 4 MONTHS AND HAD TO HAVE TWO ALIGNMENTS DONE AT SEPARATE TIMES BECAUSE THE

FIRST DIDNT INITIALLY FIX THE PROBLEM. IT CAME TO A POINT THAT I WAS FRIGHTENED TO DRIVE MY VEHICLE DURING SNOWY OR WET CONDITIONS IN FEAR OF CAUSING A MAJOR ACCIDENT. I HAVE SPENT ROUGHLY \$700 ON THIS ISSUE AND BELIEVE IT COULD HAVE BEEN RESOLVED IF GM WOULD HAVE ADDRESSED THE CONSUMER'S VEHICLE PROBLEM INITIALLY. *TR

Make : CHEVROLET **Model :** IMPALA **Year :** 2007
Manufacturer : GENERAL MOTORS LLC
Crash : No **Fire :** No **Number of Injuries:** 0
ODI ID Number : 10409210 **Number of Deaths:** 0
Date of Failure: April 1, 2011
VIN : Not Available
Component: STEERING

Summary:

TL* THE CONTACT OWNS A 2007 CHEVROLET IMPALA. THE CONTACT STATED WHILE DRIVING APPROXIMATELY 25 MPH, IN WET CONDITIONS, HE WOULD LOSE CONTROL OF THE STEERING WHEEL. IN SOME CASES, THE STEERING WHEEL WOULD SUDDENLY LOCK, MAKING IT VERY DIFFICULT TO MANEUVER THE VEHICLE. THE DEALER WAS CONTACTED AND AN APPOINTMENT WAS SCHEDULED. THE MANUFACTURER WAS NOT CONTACTED REGARDING THE FAILURE. THE FAILURE MILEAGE WAS APPROXIMATELY 80,000. THE VIN WAS UNAVAILABLE.

Make : CHEVROLET **Model :** IMPALA **Year :** 2007
Manufacturer : GENERAL MOTORS LLC
Crash : No **Fire :** No **Number of Injuries:** 0
ODI ID Number : 10398909 **Number of Deaths:** 0
Date of Failure: November 3, 2010
VIN : 2G1WD58C679...
Component: STEERING

Summary:

TL*THE CONTACT OWNS A 2007 CHEVROLET IMPALA. WHILE DRIVING APPROXIMATELY 15 MPH, THE CONTACT HEARD A CLANKING NOISE IN THE STEERING COLUMN SIMILAR TO NHTSA CAMPAIGN ID NUMBER: 09E005000 (STEERING). THE VEHICLE WAS TAKEN TO THE DEALER WHERE THEY REPLACED THE STEERING SHAFT. THE MANUFACTURER COVERED HALF THE COST. THE CURRENT MILEAGE WAS 35,000 AND THE FAILURE MILEAGE WAS 32,000. UPDATED 06/16/11*LJ

Make : CHEVROLET **Model :** IMPALA **Year :** 2007
Manufacturer : GENERAL MOTORS LLC
Crash : No **Fire :** No **Number of Injuries:** 0
ODI ID Number : 10392737 **Number of Deaths:** 0
Date of Failure: December 1, 2010
VIN : Not Available
Component: STEERING

Summary:

TL* THE CONTACT OWNS A 2007 CHEVROLET IMPALA. THE CONTACT STATED THAT WHILE THE VEHICLE WAS PARKED WITH THE ENGINE OFF, SHE NOTICED THAT THE STEERING WHEEL WOULD NOT LOCK. THE DEALER WAS CONTACTED AND THE TECHNICIAN STATED THAT THE WHEEL WOULD NEED TO BE TURNED INWARD IN ORDER FOR THE STEERING WHEEL TO LOCK. THE CONTACT FOLLOWED THE TECHNICIAN'S INSTRUCTIONS BUT TO NO AVAIL. THE CONTACT STATED THAT PRIOR TO THE FAILURE, THE IGNITION SWITCH WAS REPLACED TWICE AND REPAIRS WERE MADE TO THE STEERING COLUMN FOR A CLUNKING NOISE IN THE STEERING WHEEL. THE CONTACT WAS NOT AWARE OF THE PART THAT WAS REPLACED IN THE STEERING COLUMN AND THE PRESENT FAILURE DID NOT EXIST. THE VEHICLE WAS NOT FURTHER REPAIRED. THE VIN WAS NOT AVAILABLE. THE APPROXIMATE FAILURE MILEAGE WAS 60,000.

Make : CHEVROLET **Model :** IMPALA **Year :** 2007
Manufacturer : GENERAL MOTORS LLC
Crash : No **Fire :** No **Number of Injuries:** 0
ODI ID Number : 10374828 **Number of Deaths:** 0
Date of Failure: November 1, 2010
VIN : 2G1WT58KX79...
Component: STEERING

Summary:

TL*THE CONTACT OWNS A 2007 CHEVROLET IMPALA LT. THE CONTACT STATED THAT WHEN SHE INSPECTED HER VEHICLE SHE NOTICED THAT ALL FOUR TIRES WERE WORN EXCESSIVELY ON THE INSIDE TO THE POINT WHERE THE TREAD WAS VISIBLE. THE VEHICLE WAS NOT INSPECTED NOR HAD IT

BEEN REPAIRED. THE DEALER INFORMED HER THAT SHE SHOULD CONSIDER AN ALIGNMENT AND FOUR NEW TIRES. THE FAILURE MILEAGE WAS APPROXIMATELY 32,000.

Make : CHEVROLET **Model :** IMPALA **Year :** 2007
Manufacturer : GENERAL MOTORS LLC
Crash : No **Fire :** No **Number of Injuries:** 0
ODI ID Number : 10370569 **Number of Deaths:** 0
Date of Failure: December 6, 2010
VIN : 2G1WU58R979...
Component: STEERING

Summary:

TL* THE CONTACT OWNS A 2007 CHEVROLET IMPALA. THE CONTACT WAS DRIVING APPROXIMATELY 45 MPH AND CHANGING LANES WHEN THE STEERING WHEEL AND BRAKE PEDAL EXHIBITED AN UNUSUAL CLICKING NOISE. THE VEHICLE WAS TAKEN TO THE DEALER WHERE THE TECHNICIAN DIAGNOSED THE FAILURE WITHIN THE INTERMEDIATE SHAFT, WHICH WOULD NEED REPLACING. THE VEHICLE WAS REPAIRED. THE APPROXIMATE FAILURE MILEAGE WAS 36,700.

Make : CHEVROLET **Model :** IMPALA **Year :** 2007
Manufacturer : GENERAL MOTORS LLC
Crash : No **Fire :** No **Number of Injuries:** 0
ODI ID Number : 10369884 **Number of Deaths:** 0
Date of Failure: May 1, 2010
VIN : 2G1WB58K879...
Component: STEERING

Summary:

TL* THE CONTACT OWNS A 2007 CHEVROLET IMPALA. THE CONTACT WAS DRIVING APPROXIMATELY 3 MPH WHEN HE FELT A CLICK IN THE STEERING WHEEL AND HEARD AN ABNORMAL CLICKING NOISE. THE VEHICLE WAS TAKEN TO THE DEALER FOR DIAGNOSIS. THE TECHNICIAN INFORMED THE CONTACT THAT THE STEERING VALVE WOULD NEED TO BE REPLACED. THE VEHICLE WAS NOT REPAIRED. THE APPROXIMATE FAILURE MILEAGE WAS 27,000.

Make : CHEVROLET **Model :** IMPALA **Year :** 2007
Manufacturer : GENERAL MOTORS LLC
Crash : No **Fire :** No **Number of Injuries:** 0
ODI ID Number : 10368083 **Number of Deaths:** 0
Date of Failure: November 17, 2010
VIN : 2G1WB55K279...
Component: STEERING

Summary:

YOU CAN FEEL & HEAR THE CLUNKING/VIBRATION IN THE STEERING. *TR

Make : CHEVRDLET **Model :** IMPALA **Year :** 2007
Manufacturer : GENERAL MOTORS LLC
Crash : No **Fire :** No **Number of Injuries:** 0
ODI ID Number : 10365840 **Number of Deaths:** 0
Date of Failure: November 15, 2010
VIN : 3GNDA33P97S...
Component: STEERING

Summary:

TL* THE CONTACT OWNS A 2007 CHEVROLET HHR. THE CONTACT WAS DRIVING 35 MPH WHEN THE POWER STEERING WARNING LIGHT ILLUMINATED AND THE POWER STEERING ASSIST FAILED. IN ORDER TO RESET THE STEERING, THE VEHICLE WAS TURNED OFF AND BACK ON. THE STEERING RESUMED NORMAL OPERATION. THE VEHICLE WAS TAKEN TO THE DEALER WHERE THE ELECTRIC POWER STEERING MOTOR WAS REPLACED AT THE CONTACTS EXPENSE. THE MANUFACTURER WAS CONTACTED AND OFFERED NO ASSISTANCE. THE FAILURE MILEAGE WAS 48,688.

Make : CHEVROLET **Model :** IMPALA **Year :** 2007
Manufacturer : GENERAL MOTORS LLC
Crash : No **Fire :** No **Number of Injuries:** 0
ODI ID Number : 10359568 **Number of Deaths:** 0

Date of Failure: September 29, 2010

VIN : 2G1WT58NX79...

Component: STEERING

Summary:

TL* THE CONTACT OWNS A 2007 CHEVROLET IMPALA. THE CONTACT HAD TAKEN THE VEHICLE TO AN INDEPENDENT MECHANIC FOR ROUTINE REPAIRS WHEN SHE WAS INFORMED THAT THE INTERMEDIATE STEERING SHAFT WAS DEFECTIVE. THE VEHICLE WAS REPAIRED. DUE TO THE DEFECT FOUR TIRES HAD TO BE REPLACED WITH NEW TIRES AND A WHEEL ALIGNMENT PERFORMED. THERE WAS A TECHNICAL SERVICE BULLETIN, NUMBER 01-02-32-00101 (STEERING); ASSOCIATED WITH NHTSA ITEM NUMBER 618086. THE CONTACT HAD SIGNIFICANT CONCERN OF THE POTENTIAL SAFETY HAZARD. THE FAILURE MILEAGE WAS 38,717.

Make : CHEVROLET **Model :** IMPALA **Year :** 2007
Manufacturer : GENERAL MOTORS LLC
Crash : No **Fire :** No **Number of Injuries:** 0
ODI ID Number : 10352537 **Number of Deaths:** 0
Date of Failure: August 28, 2010
VIN : 2G1WT58K379...

Component: STEERING

Summary:

STEERING KNUCKLE IN 2007 IMPALA...STRANGE NOISE WHEN TURNING WHEEL ALL THE WAY TO THE RIGHT. *TR

Make : CHEVROLET **Model :** IMPALA **Year :** 2007
Manufacturer : GENERAL MOTORS LLC
Crash : No **Fire :** No **Number of Injuries:** 0
ODI ID Number : 10322765 **Number of Deaths:** 0
Date of Failure: April 5, 2008
VIN : 2G1WT58K179...

Component: STEERING

Summary:

I PURCHASED THIS CAR IN APRIL OF '08 AND IT HAS BEEN FAILING SINCE I BOUGHT IT. THERE IS A VIBRATION WHILE RIDING IN THE CAR THAT MAKES YOUR BODY BOUNCE. THE DEALER STATES THEY DONT FEEL IT, BUT I HAVE CRONIC BACK PAIN FROM IT. I HAVE HAD IT AT THE DEALER SEVERAL TIMES AND NO FIX. I TOOK IT TO AN ALINEMENT SHOP THEY TOLD ME THAT THE STUTS WERE SET OUT FROM THE FACTORY SO THE TIRES DONT HIT THE GROND FLAT LIKE THEY SHOULD. THE PROBLEM CAUSES MY TIRES TO SLIP OUT OF BALANCE CONSTANTLY MAKING THE VIBRATION WORSE. MY WINDSHIELD AND DASH BOTH MAKE CRAKING NOISES NOW FROM ALL THE VIBRATION IN THE CAR. IT MAKES FOR A VERY UNCOMFORTABLE RIDE. I AM ON MY 3RD SET OF TIRES AT 28,300. THE BRAKES DONT WORK PROPERLY, THE DEALER HAS TURNED THE ROTORS TWICE FOR WARPING. NOW THEY ARE GROOVED AND THEY TELL ME THAT "IT'S NORMAL" AND I DONT HAVE THE NORMAL STOPING POWER I SHOULD. THE POWER STERING SQUIELS, BUT THEY CANT HEAR IT. THE FRONT END HAS A BANGING NOISE WHEN GOING OVER BUMPS, "THEY DONT HEAR", BUT I CAN FEEL IT IN THE FLOOR BOARD WHEN IT HAPPENS. THE CAR IS SLUGGISH WHEN EXCELERATING, "NO PROBLEM FOUND". THE FUEL ECONOMY HAS DECREASED AS WELL. WHILE ON AN INCLINE THE CAR ROLDS BACKWARD LIKE A STANDARD, "IT'S NORMAL" I HAVE NEVER HAD A CAR DO THAT WITHOUT THE TRANY BEING BAD. WHEN STOPED AT A LIGHT THE TRANY TAKES A COUPLE OF SECONDS TO REENGAGE FOR TAKE OFF. TPS REPEATED PROBLEMS NOT WORKING POPERLY. THE CARS HANDLING IS VERY POOR IN THE RAIN, SNOW, OR ICE. THE MUFFLER SYSTEM HAS A LEAK AS WELL.

Make : CHEVROLET **Model :** IMPALA **Year :** 2007
Manufacturer : GENERAL MOTORS LLC
Crash : No **Fire :** No **Number of Injuries:** 0
ODI ID Number : 10321072 **Number of Deaths:** 0
Date of Failure: March 14, 2010
VIN : 2G1WD58C479...

Component: STEERING

Summary:

TL*THE CONTACT OWNS A 2007 CHEVROLET IMPALA. THE CONTACT WAS DRIVING APPROXIMATELY 70 MPH AND DETECTED THAT BOTH REAR TIRES WERE COMPLETELY DEFLATED. A WHEEL ALIGNMENT FAILURE CAUSED DAMAGE TO THE TIRES. THE VEHICLE WAS TAKEN TO AN AUTHORIZED DEALER. THE REAR PASSENGER AND DRIVER SIDE TIRES WERE REPLACED WITH A WHEEL ALIGNMENT SERVICE PERFORMED ON THE VEHICLE. THE COST OF THE SERVICE REPAIR WAS \$500. THE FAILURE MILEAGE WAS 35,000.

Make : CHEVROLET **Model :** IMPALA **Year :** 2007

Manufacturer : GENERAL MOTORS LLC**Crash :** No**Fire :** No**Number of Injuries :** 0**ODI ID Number :** 10318545**Number of Deaths :** 0**Date of Failure:** February 13, 2010**VIN :** 2G1WB58K379...**Component:** STEERING**Summary:**

DEAR NHTSA, PLEASE INVESTIGATE THE FOLLOWING SERIOUS CONCERNS THAT HAVE AFFECTED MY VEHICLE SAFETY IN ADDITION TO OTHER CHEVY IMPALA DRIVERS: VEHICLE: 2007 CHEVY IMPALA. 65,000 MILES, 1 OWNER, IMPALA LS 3.5 L V6 SAFETY CONCERN # 1- INTERMEDIATE STEERING SHAFT - GM REFUSES TO ACKNOWLEDGE THE SERIOUSNESS OF THIS PROBLEM. MY VEHICLE'S STEERING WHEEL CLICKS DURING DRIVING & TEMPORARILY JAMS CAUSING A FEELING OF DISCONNECTION FROM THE ROAD. IT HAS CAUSED A MOMENTARY LOSS OF STEERING CONTROL, AND I FEEL THIS IS A SERIOUS SAFETY CONCERN TO BE ADDRESSED. THIS IS AN ONGOING DESIGN PROBLEM FOR MANY GM MODELS (AS PER MY GOOGLE SEARCH), GM REFUSES TO MAKE CORRECTIONS TO THE DESIGN NOR ISSUE A RECALL. SAFETY CONCERN # 2- POWER STEERING PUMP- POWER STEERING PUMP LOOSING EFFECTIVENESS & TURNING PERFORMANCE, MEANING PUMP MAY BE FAILING AT ANY TIME. THIS TOO IS ANOTHER COMMON PROBLEM WITH CHEVY MODELS. PLEASE ENCOURAGE GM TO EXPAND POWER STEERING PUMP RECALL TO INCLUDE CHEVY IMPALA MODELS. SAFETY CONCERN # 3- REAR BACK SEAT CENTER SEAT BELT LOOSES TENSION WHEN USED IN CONJUNCTION WITH INFANT CAR SEAT. WHEN VEHICLE GOES AROUND 30 MILE/HR TURNS OR MILD TURNS, SEAT BELT LOCKING MECHANISM(THE ONE THAT HOLDS THE SEAT BELT TENSE DURING BRAKING) DISENGAGES & PERMITS THE SEAT BELT TO LOOSEN CAUSING CHILD SEAT TO MOVE ACROSS THE SEAT & OR IN ONE SERIOUS CASE WITH MY SON FLIP SIDEWAYS(LUCKILY MY WIFE CAUGHT THE SEAT AS IT TIPPED SIDEWAYS). I HAVE FOLLOWED ALL SAFETY INSTRUCTIONS AS PER CAR SEAT MANUFACTURER (EVENFLOW AURA TRAVEL SYSTEM). THIS IS A CONCERN, SINCE THE TENSION ONLY STAYS FIRM IN ABRUPT STOPS, THIS LEADS ME TO QUESTION THE SAFETY IN A ROLL OVER SCENARIO. I HAVE SINCE USED THE SEAT LEVEL CAR SEAT HOOKS SINCE THE PAST FEW EVENTS(THIS GREATLY REDUCES THE EASE OF SHARING THE CAR SEAT BETWEEN VEHICLES). MY OTHER VEHICLE(NISSAN ALTIMA) HAS NO SUCH PROBLEM, THE TENSION MECHANISM ON THE ALTIMA REMAINS FIRM

Make : CHEVROLET**Model :** IMPALA**Year :** 2007**Manufacturer :** GENERAL MOTORS LLC**Crash :** No**Fire :** No**Number of Injuries :** 0**ODI ID Number :** 10317488**Number of Deaths :** 0**Date of Failure:** March 7, 2010**VIN :** 2G1WS55R179...**Component:** STEERING**Summary:**

LOSS OF POWER STEERING WHEN VEHICLE TRAVELS THROUGH PUDDLE. NOTE: THIS IS A POLICE SQUAD CAR AND THIS IS THE 2ND VEHICLE OF THIS MAKE, MODEL AND YEAR THAT HAS PERFORMED THE SAME WAY. *TR

Make : CHEVROLET**Model :** IMPALA**Year :** 2007**Manufacturer :** GENERAL MOTORS LLC**Crash :** No**Fire :** No**Number of Injuries :** 0**ODI ID Number :** 10317485**Number of Deaths :** 0**Date of Failure:** October 19, 2009**VIN :** 2G1WS55R379...**Component:** STEERING**Summary:**

LOSS OF PDWER STEERING WHEN VEHICLE TRAVELS THROUGH PUDDLE OF WATER. *TR

Make : CHEVROLET**Model :** IMPALA**Year :** 2007**Manufacturer :** GENERAL MOTORS LLC**Crash :** No**Fire :** No**Number of Injuries :** 0**ODI ID Number :** 10315584**Number of Deaths :** 0**Date of Failure:** November 1, 2009**VIN :** Not Available**Component:** STEERING**Summary:**

WHEN PULLING OUT OF A PARKING LOT, I FELT A "CLUNK" AND MY CAR BECAME VERY HARD TO STEER. I CONTACTED GM AND THEY STATED THAT THERE WAS NO RECALL ON MY VEHICLE, BUT I COULD CONTACT THE DEALER AND HE MIGHT BE ABLE TO REPAIR MY VEHICLE. THE VEHICLE HAD JUST PASSED THE WARRANTY MILEAGE BY 400 MILES. I DID CONTACT THE DEALER'S SERVICE MANAGER AND HE STATED THAT THE STEERING COLUMN HAD BROKEN AT THE WELD. HE REPAIRED THE VEHICLE AT NO CHARGE.. *TR

Make : CHEVROLET **Model :** IMPALA **Year :** 2007
Manufacturer : GENERAL MOTORS LLC
Crash : No **Fire :** No **Number of Injuries :** 0
ODI ID Number : 10308701 **Number of Deaths :** 0
Date of Failure: February 1, 2010
VIN : 2G1WT58NX79...
Component: STEERING

Summary:

TL*THE CONTACT OWNS A 2007 CHEVROLET IMPALA. DURING A ROUTINE MAINTENANCE APPOINTMENT, THE DEALER TOLD HIM THAT THE STEERING SHAFT NEEDED TO BE REPLACED. HE PREVIOUSLY NOTICED A KNOCKING NOISE IN THE STEERING WHEEL AFTER IT WAS BROUGHT TO HIS ATTENTION AT THE DEALERSHIP. HE HAD NOT SPOKEN WITH THE MANUFACTURER TO-DATE. THE VEHICLE HAD NOT BEEN REPAIRED AT THE TIME OF THE COMPLAINT. THE CURRENT MILEAGE WAS APPRDXIMATELY 51,320. THE FAILURE MILEAGE WAS 51,283.

Make : CHEVROLET **Model :** IMPALA **Year :** 2007
Manufacturer : GENERAL MOTORS LLC
Crash : No **Fire :** No **Number of Injuries :** 0
ODI ID Number : 10304815 **Number of Deaths :** 0
Date of Failure: January 10, 2010
VIN : 2G1WT58K079...
Component: STEERING

Summary:

MY CAR IS A 2007 CHEVROLET IMPALA, 4DR, WHITE. I BOUGHT IT NEW FROM A DEALER IN PICKENS SC, WHO WENT OUT OF BUSINESS SOON AFTER I BOUGHT IT. I HAD NO TROUBLE WITH IT UNTIL THE INCIDENT DESCRIBED HEREIN. ON JANUARY 10, 2010, I WAS GOING DOWN RUTHERFORD ROAD IN GREENVILLE SC TO THE LAUREL BAYE HEALTHCARE HOME IN GREENVILLE SC. I TURNED INTO THE ROAD TO LAUREL BAYE FROM RUTHERFORD ROAD. THIS IS A SHARP RIGHT TURN INTO A ROAD THAT GOES UPHILL. HALFWAY THROUGH THE TURN MY CAR'S STEERING WHEEL LOCKED COMPLETELY. I COULD NOT TURN MY WHEELS AT ALL. THE CAR WAS RUNNING FINE, AND ALL OTHER SYSTEMS IN THE CAR WORKED, BUT MY STEERING WHEEL COULD NOT BE MOVED. I PUT ON MY BRAKES, WHICH WORKED, AND DROVE TO THE OTHER SIDE OF THE NARROW ROAD. I TURNED OFF THE MOTOR, AND WAITED A FEW SECONDS. THEN I TURNED MY CAR BACK ON. THE WHEELS WERE STILL LOCKED. AT THAT TIME ANOTHER CAR DROVE UP, AND THE DRIVER GOT OUT AND TRIED TO GET MY CAR WHEELS TO MOVE, WITH NO SUCCESS. IN TURN, A POLICEMAN, AND MY NEIGHBOR TRIED TO MAKE THE CAR WHEEL TURN, BUT NO SUCCESS. IN THE MEANTIME MY NEIGHBOR GOT THE CAR TO RELEASE THE WHEELS, AND I DROVE IT HOME, AND IT APPEARED TO BE OK AGAIN. THE NEXT DAY I TOOK THE CAR TO A CHEVROLET, BUICK, CADILLAC DEALER IN GREER SC. I REPORTED WHAT HAD HAPPENED, AND THEY SAID THEY WOULD EXAMINE THE CAR. THE SERVICE MAN SAID THEY COULD FIND NOTHING WRONG WITH THE CAR. THE NEXT DAY I CALLED AND THREATENED TO WRITE LETTERS OF COMPLAINT. SO THEY TOOK THE CAR AGAIN, AND KEPT IT FOR 11 DAYS TESTING IT, AND STILL REPORTED THEY COULD FIND NOTHING THAT HAD CAUSED THE WHEELS TO LOCK. IN THE MEANTIME I SEARCHED THE INTERNET AND FOUND MANY REPORTS OF GM CARS WITH THIS SAME PROBLEM. THERE HAVE BEEN CLASS ACTION SUITS, AND SUITS WHICH HAVE BEEN SETTLED BY GM. NOW I FEEL MY CAR IS UNSAFE TO DRIVE, AND I FEEL UNEASY DRIVING IT. I WOULD LIKE TO REPORT THIS INCIDENT AND HOPE THAT GM WILL BE FORCED INTO A RECALL OF ALL AFFECTED VEHICLES. *TR

Make : CHEVROLET **Model :** IMPALA **Year :** 2007
Manufacturer : GENERAL MOTORS LLC
Crash : Yes **Fire :** No **Number of Injuries :** 0
ODI ID Number : 10296059 **Number of Deaths :** 0
Date of Failure: November 22, 2009
VIN : 2G1WT58K479...
Component: STEERING

Summary:

I HIT A 6 INCH CURB AT APPROXIMATELY 30 MPH. WHEN THE CAR HIT THE CURB THE STEERING KNUCKLE BROKE CAUSING THE LEFT FRONT TIRE ASSEMBLY TO COME OFF THE CAR RENDERING ME IN NO CONTROL OF THE VEHICLE. I PERSONALLY FEEL THIS BROKE TOO EASY AND SHOULD HAVE BEEN ABLE TO WITHSTAND THE IMPACT OF A 6 INCH CURB. IF THE KNUCKLE WOULD NOT HAVE BROKE I WOULD HAVE BEEN ABLE TO STAY IN CONTROL OF THE CAR AND NOT HAVE CAUSED AS MUCH DAMAGE THAT DID OCCUR FROM THE TIRE COMING OFF THE VEHICLE. THIS SITUATION COULD PUT PEOPLE'S LIVES IN DANGER AS SUCH A SMALL IMPACT CAUSES THE WHEEL TO COME OFF TAKING CONTROL AWAY FROM THE DRIVER. *TR

Make : CHEVROLET **Model :** IMPALA **Year :** 2007
Manufacturer : GENERAL MOTORS LLC

VIN : 2G1WB55K679...

Component: STEERING

Summary:

INTERMEDIATE STEERING SHAFT. YOU CAN FEEL & HEAR THE CLUNKING/VIBRATION IN THE STEERING. I CAN ONLY IMAGINE THAT THIS WILL EVENTUALLY RESULT IN A SAFETY ISSUE. *TR

Make : CHEVROLET Model : IMPALA Year : 2007
 Manufacturer : GENERAL MOTORS LLC
 Crash : No Fire : No Number of Injuries: 0
 ODI ID Number : 10263343 Number of Deaths: 0
 Date of Failure: March 27, 2008
 VIN : 2G1WC58R379...

Component: STEERING

Summary:

INTERMEDIATE STEERING SHAFT FAILURE, AGAIN. FIRST FAILURE WAS AT TIME OF PURCHASE, APROX 26,000 MILES, STEERING SHAFT WAS REPLACED. HAVE BEEN REPORTING TO DEALERSHIPS NOISES AND UNSAFE STEERING CONCERNS EVER SINCE THEN AND NOTHING HAS BEEN DONE. NOW OUT OF WARRANTY AT 46,000 MILES, STEERING SHAFT AGAIN IS NEEDING REPLACED. FURTHER INFORMATION IS AVAILABLE AT WWW.CERTIFIEDLEMON.COM. *TR

Make : CHEVROLET Model : IMPALA Year : 2007
 Manufacturer : GENERAL MOTORS LLC
 Crash : No Fire : No Number of Injuries: 0
 ODI ID Number : 10262867 Number of Deaths: 0
 Date of Failure: April 18, 2008
 VIN : 2G1WC58R879...

Component: STEERING

Summary:

WHEN TURNING THERE'S A CLICKING NOISE . STEERING NOT SO SMOOTH, KIND OF ROUGH I BROUGHT IT TO THE DEALERSHIP WHERE I PURCHASED THE CAR. DEALER SAID THAT IT WASN'T A SAFETY ISSUE. AN THAT NOT TO WORRY, BUT THE CLICKING STILL OCCURS. JUST WANTING KNOW WHAT ACTION I NEED TO TAKE IN ORDER TO RESOLVE THIS PROBLEM. *TR

Make : CHEVROLET Model : IMPALA Year : 2007
 Manufacturer : GENERAL MOTORS LLC
 Crash : No Fire : No Number of Injuries: 1
 ODI ID Number : 10260613 Number of Deaths: 0
 Date of Failure: February 28, 2009
 VIN : Not Available

Component: STEERING

Summary:

POWER STEERING PUMP SQUEAL AND EVENTUAL FAILURE, 1ST REPORT, COULD NOT FIND SOURCE, 2ND REPORT, POWER STEERING R/R 3RD REPORT, POWER STEERING R/R. *TR

Make : CHEVROLET Model : IMPALA Year : 2007
 Manufacturer : GENERAL MOTORS LLC
 Crash : No Fire : No Number of Injuries: 0
 ODI ID Number : 10252679 Number of Deaths: 0
 Date of Failure: December 23, 2008
 VIN : 2G1WB58K179...

Component: STEERING

Summary:

2007 IMPALA LS STEERING WHEEL SHAFT. FIRST ONE REPLACED 3500 MILES SECOND AT 9500 MILES NOW AT 15500 THE THIRD ONE NEEDS TO BE REPLACED. BANGING NDISE IN FRONT CHASIS. STEERING LOOSE, WOBBLE EFFECT IN FRONT WHEELS. UNSAFE ISSUE THAT GMC CHEVY DIV WILL NOT ADDRESS JUST REPLACES. NO ONE SEEMS TO CARE, NOT GOV NOT DEALER AND NOT GM CHEVY DIVISION. WHAT CAN I DO? *TR

Make : CHEVROLET Model : IMPALA Year : 2007

Manufacturer : GENERAL MOTORS LLC**Crash :** No**Fire :** No**Number of Injuries :** 0**ODI ID Number :** 10249401**Number of Deaths :** 0**Date of Failure:** November 17, 2008**VIN :** 2G1WT58N179...**Component:** STEERING**Summary:**

RIGHT AFTER I HIT 36,000 MILES ON MY CAR, I STARTED HEARING A CLUNK SOUND FROM THE STEERING WHEEL. I BROUGHT IT INTO THE DEALERSHIP, AND THE GENTLEMAN TOLD ME IT WAS PROBABLY THE STEERING SHAFT. I ASKED IF THIS WAS A COMMON PROBLEM, AND IF IT WAS COVERED UNDER MY EXTENDED WARRANTY. I WAS TOLD YES, IT IS A COMMON PROBLEM, AND NO, ITS ONLY COVERED UNDER THE 36000 MILE WARRANTY. NOT THE 50,000. I ASKED WHY THIS ISN'T COVERED SEEING AS ITS A PART THAT SHOULD NEVER GO ON YOUR CAR, ESPECIALLY AFTER ONLY 36000 MILES. HIS REPLY SHOCKED ME WHEN HE SAID THAT ALL THE ONES HE'S SEEN BREAK BEFORE THE 36,000! ADDED ONTO THIS, MY CAR REMOTE JUST STOPPED WORKING, AS WELL AS MY TIRE MONITOR SYSTEM IS UNABLE TO BE RESET! BASICALLY AFTER OWNING THIS CAR LESS THAN A YEAR, I'M STARTING TO FEEL THAT I HAVE JUST BOUGHT A NICE NEW LEMON! *TR

Make : CHEVROLET**Model :** IMPALA**Year :** 2007**Manufacturer :** GENERAL MOTORS LLC**Crash :** No**Fire :** No**Number of Injuries :** 0**ODI ID Number :** 10231158**Number of Deaths :** 0**Date of Failure:** October 1, 2007**VIN :** 2G1WB58K179...**Component:** STEERING**Summary:**

2007 IMPALA LS PURCHASED MAY 31, 2007. DEFECTIVE STEERING WHEEL SHAFT REPLACED AT 4573 MILES ON OCT 1, 2007. BINDING NOISE NOTED, CLUNKING SOUND ON BUMPS AND TURNS LEFT OR RIGHT. SAME CONDITIONS ARE APPEARING AGAIN JUNE 16, 2008 AT 9500 MILES. NO FAILURE HOWEVER SUSPECT IF IGNORED SHAFT COULD FAIL CAUSING CATASTROPHIC FAILURE OF VEHICLE STEERING. *TR

Make : CHEVROLET**Model :** IMPALA**Year :** 2007**Manufacturer :** GENERAL MOTORS LLC**Crash :** No**Fire :** No**Number of Injuries :** 0**ODI ID Number :** 10207569**Number of Deaths :** 0**Date of Failure:** September 17, 2007**VIN :** 2G1WT55K279...**Component:** STEERING**Summary:**

TL*THE CONTACT OWNS A 2007 CHEVROLET IMPALA. WHILE TURNING THE VEHICLE AT VARIOUS SPEEDS, THE CONTACT HEARD A LOUD CLICKING SOUND COMING FROM THE STEERING COLUMN. SHE TOOK THE VEHICLE TO THE DEALER AND THEY REPLACED THE STEERING COLUMN. FOUR DAYS LATER, THE NOISE RETURNED AND THE DEALER REPLACED THE TIE RODS. ONE MONTH LATER, THE NOISE OCCURRED FOR THE THIRD TIME AND THE STEERING GEAR MECHANISM WAS REPLACED. THE CONTACT IS CURRENTLY EXPERIENCING THE SAME FAILURE FOR THE FOURTH TIME. THE DEALER WAS UNABLE TO DETERMINE THE CAUSE OF FAILURE AND REPAIR THE VEHICLE. SHE FILED A COMPLAINT WITH THE MANUFACTURER. THE PURCHASE DATE WAS UNKNOWN. THE FAILURE MILEAGE WAS 24,498 AND CURRENT MILEAGE WAS 26,691. THE CONSUMER STATED AFTER THREE REPAIRS THE PROBLEM STILL PERSISTS. UPDATED 11/14/07 *TR

Make : CHEVROLET**Model :** IMPALA**Year :** 2007**Manufacturer :** GENERAL MOTORS LLC**Crash :** No**Fire :** No**Number of Injuries :** 0**ODI ID Number :** 10206184**Number of Deaths :** 0**Date of Failure:** June 25, 2007**VIN :** 2G1WT58K779...**Component:** STEERING**Summary:**

HEARD A CLUNKING NOISE UNDER FEET (DRIVER'S SIDE), CAN FEEL CLUNKING WHEN HOLDING STEERING WHEEL. HAVE HAD IN 4 TIMES NOW. 1ST - REPLACED STEERING SHAFT, 2ND - REPLACED MOTOR MOUNTS, 3RD - COULDN'T FIND ANYTHING OR DUPLICATE PROBLEM...KEPT OVERNIGHT, 4TH - LUBES STEERING SHAFT. PROBLEM STILL NOT FIXED!!!! *JB

Make : CHEVROLET**Model :** IMPALA**Year :** 2007

Manufacturer : GENERAL MOTORS LLC

Crash : No

Fire : No

Number of Injuries: 0

ODI ID Number : 10199930

Number of Deaths: 0

Date of Failure: August 15, 2007

VIN : 2G1WB58NX79...

Component: STEERING

Summary:

STEERING ISSUE WITH 2007 CHEVROLET IMPALA. WHEN MAKING TURNS, I CAN HEAR AND FEEL A CLUNKING NOISE IN THE STEERING WHEEL. THE VEHICLE ONLY HAS 700 MILES ON IT. THE DEALER IS SUPPOSED TO REPLACE THE STEERING SHAFT WHEN THE PART IS AVAILABLE. I WENT TO THE DEALER TWICE WITH THIS CONCERN. THE FIRST TIME, THEY JUST LUBED THE STEERING SHAFT. THAT DID NOT HELP THE PROBLEM AT ALL. TWO DAYS LATER I WENT BACK TO THE DEALER, AND THAT IS WHEN THEY SAID THEY WILL REPLACE THE SHAFT. *TR

Make : CHEVROLET

Model : IMPALA

Year : 2007

Manufacturer : GENERAL MOTORS LLC

Crash : No

Fire : No

Number of Injuries: 0

ODI ID Number : 10187437

Number of Deaths: 0

Date of Failure: January 26, 2007

VIN : 2G1WC58R079...

Component: STEERING

Summary:

TL*THE CONTACT OWNS A 2007 CHEVROLET IMPALA. WHILE ATTEMPTING TO TURN THE VEHICLE AT 15 MPH THROUGH A PUDDLE OF WATER THE STEERING WHEEL LOCKED. THE VEHICLE WAS BROUGHT TO THE DEALER FOUR TIMES ,AND THE SERPENTINE BELT AND TENSIONER WERE REPLACED. THE VEHICLE WAS PLACED ON A DIAGNOSTIC MACHINE ON SEVERAL OCCASIONS, BUT THE CAUSE OF FAILURE COULD NOT BE DETERMINED. THE CURRENT MILEAGE 5,600, AND FAILURE MILEAGE WAS 3,200. *AK THE DEALER STATED HAD TO PERFORM ELECTRICAL DIAGNOSTIC AND VERIFIED AIR BAG LIGHT ON AND TIRE MONITOR SYSTEM WAS ON, THE DEALER REPAIRED BOTH DEFECTS. THE CONSUMER STATED WANTS TO BE EITHER REIMBURSED FOR REPAIRS AND OR NEW VEHICLE AND OR BE REPLACED. THE AIR BAG LIGHT ILLUMINATED AND THERE WAS ALSO A PORLBME WITH THE POWER STEERING LOCKING UP. UPDATED 05/22/07*TR

1200 New Jersey Avenue, SE, West Building Washington DC 20590 USA
1.888.327.4236 TTY 1.800.424.9153



VEHICLES AND THE 2008 CHEVROLET IMPALA POLICE CRUISERS. THE CONTACT DID NOT CONFIRM IF THE VEHICLE WAS INCLUDED IN THE RECALL. THE VEHICLE WAS NOT BEEN REPAIRED. THE MANUFACTURER WAS NOTIFIED OF THE PROBLEM. THE APPROXIMATE FAILURE MILEAGE WAS 72,000.

Make : CHEVROLET **Model :** IMPALA **Year :** 2007
Manufacturer : GENERAL MOTORS LLC
Crash : No **Fire :** No **Number of Injuries:** 0
ODI ID Number : 10451851 **Number of Deaths:** 0
Date of Failure: August 29, 2008
VIN : 2G1WD58CX79...
Component: SUSPENSION

Summary:

DURING THE COURSE OF OWNING THIS IMPALA SINCE IT WAS NEW, IT HAS HAD 12 REPLACEMENT TIRES INSTALLED IN ORDER TO CORRECT A VIBRATION PROBLEM, WHICH IS FELT AT OR AROUND 55 MPH. IT HAS TAKEN APPROXIMATELY 10,000 MILES FOR EACH OF THE TIRES TO WEAR UNEVENLY. EACH TIME A TIRE WAS REPLACED, I WAS GIVEN AN EXPLANATION THAT THE DEFECTIVE TIRE WAS NO LONGER ROUND (EGG SHAPED) AND WOULD NOT PROPERLY BALANCE. A MAJORITY OF THE DEFECTIVE TIRES WERE FROM THE REAR OF THE IMPALA. THE LAST REPLACEMENT TIRES WERE INSTALLED ON 06-28-10 WHEN THE VEHICLE HAD 26,264 MILES ON IT. DURING THE DOZENS OF VISITS TO MULTIPLE CHEVROLET SERVICE DEPTS, NO MECHANICAL SUSPENSION PARTS WERE REPLACED. I'VE BEEN IN CONTACT WITH THE GENERAL MOTORS EXECUTIVE CUSTOMER SERVICE OFFICE (GMECSO) FOR YEARS AND HAVE DEALT WITH MULTIPLE REPRESENTATIVES. THE IMPALA AGAIN HAS A VIBRATION, AND I WOULD LIKE TO GET THE VEHICLE SERVICED. GMECSO INFORMED ME THAT THEY WANTED ME TO TAKE THE IMPALA TO A DIFFERENT CHEVROLET SERVICE DEPARTMENT IF I NEEDED TO GET THE CAR LOOKED AT FOR ISSUES REGARDING THE TIRES. SINCE 02-05-12, I HAVE MADE 5 PHONE CALLS TO THE GMECSO AND HAVE YET TO RECEIVE A CALL BACK. *TR

Make : CHEVROLET **Model :** IMPALA **Year :** 2007
Manufacturer : GENERAL MOTORS LLC
Crash : No **Fire :** No **Number of Injuries:** 0
ODI ID Number : 10449019 **Number of Deaths:** 0
Date of Failure: June 16, 2006
VIN : 2G1WU56R479...
Component: SUSPENSION

Summary:

I NOTICED THINGS ABOUT MY CAR BUT IGNORED THEM BECAUSE I THOUGHT, THIS IS A BRAND NEW CAR AND IT SHOULDN'T HAVE ANY ISSUES. FROM THE VERY BEGINNING I WOULD NOTICE THAT MY CAR WOULD SLIDE A LOT WHEN THERE WAS SNOW/ICE/RAIN ON THE GROUND. AS IF IT WASN'T SITTING ON THE GROUND PROPERLY. I WOULD LOOK AT IT FROM THE REAR AT A DISTANCE AND IT ALWAYS SEEMED TO SLANT/DROOP AT AN ANGLE. ABOUT A YEAR AND HALF OF OWNERSHIP WHILE GETTING MY OIL CHANGED A SERVICE TECH FROM AN AUTHORIZED CHEVROLET DEALER INFORMED ME THAT I HAD EXCESSIVE TIRE WEAR AND STATED THAT I NEEDED ALL NEW TIRES. NOTE HE NEVER STATED THAT I NEEDED A WHEEL ALIGNMENT OR THAT THERE WAS A POSSIBLE RECALL NOTICE THAT WE COULD FIX WHILE YOUR CAR IS STILL UNDER. HE JUST WANTED TO SELL ME TIRES. FROM DOING MY RESEARCH IT LOOKS LIKE I AM NOT ALONE WITH THE ISSUE OF EXCESSIVE TIRE WEAR. LOOKS LIKE GM IS ALSO AWARE OF THIS ISSUE. THERE IS A GM BULLETIN 08032 BUT GM ONLY STATES THAT GOVERNMENT CARS ARE AFFECTED. I KNOW OF SEVERAL PEOPLE THAT WORK ON GM ASSEMBLY LINES AND THEY WILL STATE THAT THERE IS NO DIFFERENCE, SO WHY HAS THERE NOT BEEN A RECALL ON THIS ISSUE. THIS IS VERY DANGEROUS FOR GM TO KNOWING KNOW THAT SOMETHING IS NOT CORRECT ON THESE CARS AND THEY ARE REFUSING TO DO ANYTHING ABOUT IT. HOW MANY LIVES HAVE BEEN LOST OR HAVE TO BE LOST FOR GM TO CALL A RECALL AND FIX THE ISSUE ON THESE CARS. UPDATE 2/22/2012: I HAVE GOTTEN THE "NEEDED" "SPECIAL" WHEEL ALIGNMENT BUT AM STILL CONSTANTLY REPLACING TIRES THAT HAVE BEEN ON MY CAR NOT EVEN A YEAR. WILL NEVER BUY A CHEVY AGAIN. NOT REPUTABLE AND DOING THE RIGHT THING WHICH IS TO CORRECTLY FIX OVER 400,000 CARS. *TR

Make : CHEVROLET **Model :** IMPALA **Year :** 2007
Manufacturer : GENERAL MOTORS LLC
Crash : No **Fire :** No **Number of Injuries:** 0
ODI ID Number : 10448932 **Number of Deaths:** 0
Date of Failure: February 1, 2012
VIN : 2G1WD58C779...
Component: SUSPENSION

Summary:

MASSIVE REAR TIRE PREMATURE WEAR CAUSED BY DEFECTIVE DESIGN AND DEFECTIVE TRI-COILED REAR SPRINGS, TRAILING ARMS, AND SPINDLE RODS. *TR

Make : CHEVROLET **Model :** IMPALA **Year :** 2007
Manufacturer : GENERAL MOTORS LLC

THE PROBLEMS. YOU FOLKS HAVE TO DEMAND THAT G.M. RECALL AND REPAIR EVERY CAR 2007-2008 IMPALAS WITH PROBLEM. ONE SET OF TIRES ON THIS CAR WORE A STRIP 2 INCHES WIDE FROM OUTSIDE EDGES TOWARD CENTER IN 4 MONTHS MY MECHANIC WHO WAS CHANGING THE OIL CALLED ME OUT TO LOOK AT THEM. HE HAD PUT THEM ON THE CAR. THEY WERE DOWN TO CANVAS AND STEEL BELT, MY WIFE DRIVES THIS VEHICLE AND SHE NEVER NOTICED ANYTHING THIS WAS SHEAR CHANGE IN SPOTTING PROBLEM I FEEL THIS IS VERY DANGEROUS PROBLEM. A HIGH SPEED BLOWOUT ON INTER STATE, THE ONLY PLACE SHE DRIVES FAST TO VISIT KIDS WOULD HAVE BEEN CATASTROPHE. PLEASE TAKE ACTION ON THESE CARS 400,000 PLUS SOLD AND OVER 20,000 TO POLICE WHICH WERE RE-CALLED AND FIXED BEST REGARDS [XXX] INFORMATION REDACTED PURSUANT TO THE FREEDOM OF INFORMATION ACT (FOIA), 5 U.S.C. 552(B)(6) *KB

Make : CHEVROLET Model : IMPALA Year : 2007
 Manufacturer : GENERAL MOTORS LLC
 Crash : No Fire : No Number of Injuries: 0
 ODI ID Number : 10435578 Number of Deaths: 0
 Date of Failure: August 1, 2007
 VIN : 2G1WC58R179...
 Component: SUSPENSION

Summary:

TL* THE CONTACT OWNS A 2007 CHEVROLET IMPALA. THE CONTACT STATED THAT THE REAR TIRES WOULD WEAR PREMATURELY. THE CONTACT BELIEVED THAT THERE WAS AN ISSUE WITH THE REAR AXLE THAT WAS AFFECTING THE TIRES. THE DEALER AND THE MANUFACTURER WERE NOTIFIED OF THE FAILURE, BUT DENIED ANY ASSISTANCE WITH REPAIRS TO THE VEHICLE. THE VEHICLE WAS NOT REPAIRED. THE FAILURE MILEAGE WAS UNAVAILABLE AND THE CURRENT MILEAGE WAS 55,000.

Make : CHEVROLET Model : IMPALA Year : 2007
 Manufacturer : GENERAL MOTORS LLC
 Crash : No Fire : No Number of Injuries: 0
 ODI ID Number : 10432931 Number of Deaths: 0
 Date of Failure: October 8, 2008
 VIN : 2G1WB58K379...
 Component: SUSPENSION

Summary:

07 IMPALA FOR EXCESSIVE FRONT TIRE WEAR NOT REAR AS HAS BEEN THE PROBLEM. CAR HAS NOW 52,000 MILES ON IT . DEALERSHIP HAS TESTED THE CAR FOR PROBLEM WITH REAR ALIGNMENT BOLTS, CHECKED IT TO GM SPECS. CONTACTED GM WHO SAID THERE WAS NO PROBLEM WITH THE CAR. CAR GOES THROUGH A SET OF FRONT TIRES APPROX EVERY 15000 MILES. COMPLAINT STARTED AFTER REPLACING FIRST SET OF TIRES @ 16,000 MILES

Make : CHEVROLET Model : IMPALA Year : 2007
 Manufacturer : GENERAL MOTORS LLC
 Crash : No Fire : No Number of Injuries: 0
 ODI ID Number : 10422113 Number of Deaths: 0
 Date of Failure: August 21, 2011
 VIN : 2G1WD58C679...
 Component: SUSPENSION

Summary:

TRAVELING EASTBOUND ON I-90, LOW TIRE PRESSURE WARNING CAME ON, I PULLED OVER TO CHECK MY TIRES AND NOTICED THAT JUST THE INSIDE OF MY REAR TIRES WERE WORN DOWN TO THE BELTS, HOWEVER VERY LITTLE WEAR ON THE OUT SIDE OF THE TIRE. I VISUALLY CHECKED THE TIRE PRIOR TO GETTING ON THE HIGHWAY AND DID NOT NOTICE ANY WEAR. AFTER DOING SOME RESEARCH, I FOUND THIS IS A COMMON PROBLEM WITH THIS MODEL. THIS IS DEFINITELY A SAFETY ISSUE.

Make : CHEVROLET Model : IMPALA Year : 2007
 Manufacturer : GENERAL MOTORS LLC
 Crash : No Fire : No Number of Injuries: 0
 ODI ID Number : 10414608 Number of Deaths: 0
 Date of Failure: July 21, 2011
 VIN : 2G1WT58K079...
 Component: SUSPENSION

Summary:

THE CAR HAS ALIGNMENT PROBLEM. WHILE DRIVING I NEVER FELT CONFIDENT ABOUT THE FEEL AND FELT LIKE TRACTION WAS NOT WAS NOT GOOD. ORIGINAL SET OF TIRES PREMATURELY FAILED AROUND 30,000 MILES. EXCESSIVE WEAR ON THE INSIDE. WHEN COMPLAINED THE DEALER SAID IT

NEEDED ALIGNMENT AND PERFORMED ON THE FRONT WHEELS. AFTER THAT I REPLACED ALL 4 TIRES. UPON EXAMINING THE TIRES RECENTLY I REALIZED THAT THE REAR TIRES ARE WEARING UNEVENLY, INSIDE WAS WEARING FAST. THE ROAD NOSE FROM THE REAR WHEELS WAS INCREASING STEADILY. HOWEVER THE FRONT TIRES SEEMS TO BE FINE. WHEN I CALLED THE DEALER WITH THE PROBLEM, HE SUGGESTED ALL WHEEL ALIGNMENT FOR WHICH I WILL HAVE TO PAY. I STRONGLY BELIEVE THE PROBLEM WAS DUE TO DEFECTIVE PARTS/INSPECTION PRIOR TO DELIVERY.

Make : CHEVROLET **Model :** IMPALA **Year :** 2007
Manufacturer : GENERAL MOTORS LLC
Crash : No **Fire :** No **Number of Injuries :** 0
ODI ID Number : 10412411 **Number of Deaths :** 0
Date of Failure: July 15, 2008
VIN : 2G1WT55N079...

Component: SUSPENSION

Summary:

TL* THE CONTACT OWNS A 2007 CHEVROLET IMPALA. THE CONTACT STATED THAT ALL FOUR TIRES WERE CONSISTENTLY WEARING FROM THE INSIDE AND WERE CONSTANTLY IN NEED OF REPLACEMENT AND AN ALIGNMENT. THE DEALER WAS CONTACTED WHO OFFERED NO ASSISTANCE FOR THE REPAIRS. THE MANUFACTURER WAS CONTACTED ABOUT THE FAILURE BUT OFFERED NO ASSISTANCE. THE FAILURE MILEAGE WAS 71,209. UPDATED 08/15/11 *BF UPDATED 08/24/11. *JB

Make : CHEVROLET **Model :** IMPALA **Year :** 2007
Manufacturer : GENERAL MOTORS LLC
Crash : No **Fire :** No **Number of Injuries :** 0
ODI ID Number : 10412332 **Number of Deaths :** 0
Date of Failure: April 15, 2010
VIN : 2G1WT58K279...

Component: SUSPENSION

Summary:

TL* THE CONTACT OWNS A 2007 CHEVROLET IMPALA. THE CONTACT STATED THAT THE REAR TIRES WERE REPLACED THREE TIMES WITHIN THE LAST YEAR DUE TO EXCESSIVE TREAD WEAR AND BLOWOUTS. THE VEHICLE WAS TAKEN TO AN AUTHORIZED DEALER WHERE THE REAR SUSPENSION WAS REALIGNED AND THE STRUTS WERE REPLACED, BUT THE REPAIRS DID NOT REMEDY THE FAILURE. THE CONTACT WAS ALSO INFORMED THAT THERE WAS AN ARM KIT THAT COULD BE INSTALLED ON THE VEHICLE TO REMEDY THE FAILURE. THE MANUFACTURER WAS MADE AWARE OF THE SITUATION AND THE CONTACT WAS INFORMED THAT THE ARM KIT WOULD NOT REMEDY THE FAILURE. ADDITIONAL REPAIRS WERE NOT PERFORMED. THE FAILURE MILEAGE WAS 57,059 AND THE CURRENT MILEAGE WAS UNKNOWN.

Make : CHEVROLET **Model :** IMPALA **Year :** 2007
Manufacturer : GENERAL MOTORS LLC
Crash : No **Fire :** No **Number of Injuries :** 0
ODI ID Number : 10411514 **Number of Deaths :** 0
Date of Failure: May 15, 2010
VIN : 2G1WT58K679...

Component: SUSPENSION

Summary:

MY 2007 IMPALA TIRES WORE OUT PREMATURELY. I NOTICED THE TIRES STARTING TO WEAR OUT ON THE INSIDE AT ABOUT 6,000 MILES AND HAD THE TIRES ALIGNED AND ROTATED. THE TIRES CONTINUED TO WEAR OUT ON THE INSIDE. I BROUGHT THIS TO THE ATTENTION OF LUCK CHEVROLET AT ABOUT 32,000 MILES AND THEY SAID GM WOULD NOT COVER THIS REPAIR UNDER THE WARRANTY. HOWEVER THEY DID SAY THERE WAS A PROBLEM AND A KIT COULD BE INSTALLED TO CORRECT. I REPLACED THE TIRES AND HAD GOODYEAR INSTALL THE CAMBER KIT TO CORRECT THE PROBLEM. I SPENT \$800 FOR NEW TIRES WHEEL ALIGNMENT AND THE CAMBER KIT. *TR

Make : CHEVROLET **Model :** IMPALA **Year :** 2007
Manufacturer : GENERAL MOTORS LLC
Crash : No **Fire :** No **Number of Injuries :** 0
ODI ID Number : 10412468 **Number of Deaths :** 0
Date of Failure: May 6, 2008
VIN : 2G1WT58K479...

Component: SUSPENSION

Summary:

I HAD A COMPANY CAR, 2007 IMPALA THAT WAS WEARING THE TIRES UNEVENLY. I WENT THROUGH

SEVERAL SETS OF TIRES AS A RESULT OF THIS PROBLEM. I THOUGHT THAT THE TIRE DEALERSHIP WAS NOT DOING A GOOD JOB HOWEVER JUST NOTICED THAT THERE IS LAWSUIT STATING THERE WAS A PROBLEM WITH THE SPINDLES. MY FATHER, NOW OWNS THE VEHICLE. AND WANT TO BRING THIS TO THE NHTSA ATTENTION AS WELL AS TO BE NOTIFIED OF A RECALL AS MY FATHER IS NOW DRIVING THE VEHICLE.

Make : CHEVROLET **Model :** IMPALA **Year :** 2007
Manufacturer : GENERAL MOTORS LLC
Crash : No **Fire :** No **Number of Injures :** 0
ODI ID Number : 10383631 **Number of Deaths :** 0
Date of Failure: February 1, 2011
VIN : 2G1WT58N479...
Component: SUSPENSION

Summary:

CAR IS ALMOST UNDRIVABLE IN COLD WEATHER CLIMATES SNOW AND ICE,ALIGNMENT IS SO FAR OFF DUE TO SUSPENSION COMPONENT PROBLEMS DESCRIBED BY GM IN A TSB,REAR OF CAR WANTS TO COME AROUND,ALL OVER THE ROAD,SCARY TO DRIVE,TIRES ARE WORN OUT ON INSIDE EDGES AFTER 19K OF DRIVING,WE PURCHASED WITH 8890K,GM SAYS NOTHING WRONG TSB ONLY PERTAINS TO POLICE VERSIONS,A CROCK OF S--T,SOMEBODY WILL LOSE THEIR LIFE IN THESE DEATH TRAPS,LOOKING AT OVER \$1100.00 TO REPAIR REPLACE TIRES AND COMPONENTS WITH ALIGNMENT ON A CAR WITH 19K,SHOULD HAVE GONE OUT OF BUSINESS,UNSAFE CAR TO DRIVE.

Make : CHEVROLET **Model :** IMPALA **Year :** 2007
Manufacturer : GENERAL MOTORS LLC
Crash : No **Fire :** No **Number of Injures :** 0
ODI ID Number : 10380994 **Number of Deaths :** 0
Date of Failure: January 16, 2011
VIN : 2G1WC58R079...
Component: SUSPENSION

Summary:

I HAD MY TRANSMISSION REPAIRED WHEN THE TECHNICIAN REALIZED MY BRAND NEW TIRES WERE WORN TO THE CORDS ON THE INSIDE. THEY SAID IT WAS THE SHOCKS AND STRUTS . WHEN THEY CALLED TO GET THE WARRANTY TO COVER THE PROBLEM THE WARRANTY INSPECTOR SAID IT WASN'T THE PROBLEM. THE PROBLEM WAS AN ALIGNMENT PROBLEM THAT REQUIRED HOLES TO BE DRILLED AND A BOLT BE PUT IN. THIS IS SOMETHING THAT GM KNOWS ABOUT BECAUSE THEY HAVE A KIT BUT THE WARRANTY CONSIDERS THIS AN UPDATE NOT A PROBLEM. I HAVE TO REPAIR THIS PROBLEM AND REPLACE NEW TIRES. I WANT TO KNOW WHY GM ISN'T RECALLING THE CAR TO PUT THESE BOLTS IN. *LN

Make : CHEVROLET **Model :** IMPALA **Year :** 2007
Manufacturer : GENERAL MOTORS LLC
Crash : No **Fire :** No **Number of Injures :** 0
ODI ID Number : 10380944 **Number of Deaths :** 0
Date of Failure: February 2, 2011
VIN : Not Available
Component: SUSPENSION

Summary:

DURING THE RECENT SNOW STORM, I DISCOVERED THAT MY VEHICLE CONSTANTLY SKIDDED AND THE REAR OF THE VEHICLE SWAYED BACK AND FORTH WHEN GOING OVER ICE OR SNOW AT A SPEED AS LOW AS 15 MPH. DUE TO THIS PROBLEM, I WAS ALMOST INVOLVED IN MORE THAN ONE TRAFFIC ACCIDENTS. I JUST PURCHASED THE VEHICLE 3 MONTHS AGO AND NOW FEEL VERY UNSAFE DRIVING IT. I DID SOME RESEARCH AND DISCOVERED THAT THERE ARE MANY PEOPLE OUT THERE THAT EXPERIENCED THE SAME PROBLEM. SINCE THIS IS SO UNSAFE, THIS VEHICLE SHOULD BE RECALLED AND THE PROBLEM CORRECTED. HOW CAN I GET THIS PROBLEM FIXED? I HATE TO HAVE TO GO THROUGH THE TROUBLE OF SELLING THE VEHICLE DUE TO A MANUFACTURER'S DEFECT. *LN

Make : CHEVROLET **Model :** IMPALA **Year :** 2007
Manufacturer : GENERAL MOTORS LLC
Crash : No **Fire :** No **Number of Injuries :** 0
ODI ID Number : 10366487 **Number of Deaths :** 0
Date of Failure: November 15, 2010
VIN : 2G1WB58K679...
Component: SUSPENSION

Summary:

I RECENTLY NOTICED THAT MY 2007 CHEVY IMPALA IS VERY DANGEROUS IN INCLEMENT WEATHER.

TONIGHT I ALMOST DIED! WHILE I WAS TRAVELING ON THE INTERSTATE THE CAR SWERVED OUT OF CONTROL CONSISTENTLY FOR AT LEAST 10 MILES. SEMIS WERE SURROUNDING ME AS MY CAR WAS GOING OUT OF CONTROL. AFTER READING SIMILAR COMPLAINTS I'VE REALIZED THAT THIS MAY BE A MANUFACTURING ISSUE AND NOT THE TIRES THAT I RECENTLY PUT ON. I WAS LITERALLY SCARED TO DEATH. HOW CAN THE US GOVERNMENT ALLOW THIS ISSUE TO GO UNCHECKED. HEY WHY DON'T WE JUST BAIL OUT SOME MORE US AUTO COMPANIES LIKE GM SO THEY CAN KEEP MAKING POS CARS. *TR

Make : CHEVROLET **Model :** IMPALA **Year :** 2007
Manufacturer : GENERAL MOTORS LLC
Crash : No **Fire :** No **Number of Injuries :** 0
ODI ID Number : 10357307 **Number of Deaths :** 0
Date of Failure: April 13, 2009
VIN : Not Available
Component: SUSPENSION

Summary:

FRONT AND REAR ABNORMAL TIRE WEAR BROUGHT ON BY IMPROPER WHEEL ALIGNMENT FROM THE MANUFACTURER. AT 22000 MILES A VIBRATION COULD BE FELT AT SPEEDS ABOVE 20 MPH. I TOOK THE CAR IN FOR A CHECK AR A LOCAL TIRE DEALER. THE TECH CALLED ME OUT TO THE CAR WHILE IT WAS ON A LIFT. HE SHOWED ME THE TIRES, ALL FOUR WERE WORN BEYOND USE. THE INNER TWO TREAD LINES WERE COMPLETELY WORN OFF, I FELT THE TIRE IN THE WORN AREA AND IT FELT LIKE A BALLOON. THE TECH COMMENTED I WAS FORTUNATE TO HAVE MADE IT TO THE SHOP. HE WAS SURPRISED THE HAO NOT BLOWN UP WHILE DRIVING. LATER HE TOLD ME THAT THE CAR DID NOT HAVE ECCENTRIC BOLTS IN THE SUSPENSION AND THAT HE WOULD HAVE TO REPLACE THE NON ADJUSTABLE BOLTS IN THE SUSPENSION ALONG WITH 4 NEW TIRES. WHILE I WAS WAITING IN THE LOBBY I DECIDED TO CHECK ON THE PROGRESS, WHEN I NOTICED AN 2008 IMPALA ON ANOTHER RACK, I LOOKED AT THE TIRES AND SAW THE SAME PROBLEM I HAD. OVER 600.00 DOLLARS I WAS ON MY WAY HOME. I CONTACTED THE CHEVY DEALER ON TO GET A GAF FROM THE SERVICE DEPT. OKAY SO I SUCK KT UP, DUMP THE CAR AND NOT BUY CHEVYS AGAIN. THIS WAS MY 4TH NEW CHEVY FROM THE SAME DEALER, NEVER AGAIN. I'M BUYING GERMAN OR JAPANESE. *TR

Make : CHEVROLET **Model :** IMPALA **Year :** 2007
Manufacturer : GENERAL MOTORS LLC
Crash : No **Fire :** No **Number of Injuries :** 0
ODI ID Number : 10328525 **Number of Deaths :** 0
Date of Failure: April 30, 2010
VIN : 2G1WB58K079...
Component: SUSPENSION

Summary:

2007 CHEVROLET IMPALA. PREMATURE TIRE WEAR*CW THE CONSUMER ALSO HAS ANOTHER COMPLAINT WITH A DIFFERENT VEHICLE. ODI # 10334853. UPDATED 06/04/10.*JB THE CONSUMER IS REQUESTING AN INSPECTION OF THE VEHICLE. HE WOULD LIKE THE STRUTS AND FRONT END TO BE INSPECTED. UPDATED 08/12/10*JB

Make : CHEVROLET **Model :** IMPALA **Year :** 2007
Manufacturer : GENERAL MDTORS LLC
Crash : No **Fire :** No **Number of Injuries :** 0
ODI ID Number : 10322765 **Number of Deaths :** 0
Date of Failure: April 5, 2008
VIN : 2G1WT58K179...
Component: SUSPENSION

Summary:

I PURCHASED THIS CAR IN APRIL OF '08 AND IT HAS BEEN FAILING SINCE I BOUGHT IT. THERE IS A VIBRATION WHILE RIDING IN THE CAR THAT MAKES YOUR BODY BOUNCE. THE DEALER STATES THEY DON'T FEEL IT, BUT I HAVE CRONIC BACK PAIN FROM IT. I HAVE HAD IT AT THE DEALER SEVERAL TIMES AND NO FIX. I TOOK IT TO AN ALINEMENT SHOP THEY TOLD ME THAT THE STUTS WERE SET OUT FROM THE FACTORY SO THE TIRES DON'T HIT THE GROND FLAT LIKE THEY SHOULD. THE PROBLEM CAUSES MY TIRES TO SLIP OUT OF BALANCE CONSTANTLY MAKING THE VIBRATION WORSE. MY WINDSHIELD AND DASH BOTH MAKE CRANKING NOISES NOW FROM ALL THE VIBRATION IN THE CAR. IT MAKES FOR A VERY UNCOMFORTABLE RIDE. I AM ON MY 3RD SET OF TIRES AT 28.300. THE BRAKES DON'T WORK PROPERLY, THE DEALER HAS TURNED THE ROTORS TWICE FOR WARPING. NOW THEY ARE GROOVED AND THEY TELL ME THAT "IT'S NORMAL" AND I DON'T HAVE THE NORMAL STDPING POWER I SHOULD. THE POWER STERING SQUIELS, BUT THEY CAN'T HEAR IT. THE FRONT END HAS A BANGING NOISE WHEN GOING OVER BUMPS "THEY DON'T HEAR" BUT I CAN FEEL IT IN THE FLOOR BOARD WHEN IT HAPPENS. THE CAR IS SLUGGISH WHEN EXCELERATING "NO PROBLEM FOUND". THE FUEL ECONOMY HAS DECREASED AS WELL. WHILE ON AN INCLINE THE CAR ROLES BACKWARD LIKE A STANDARD."IT'S NORMAL" I HAVE NEVER HAD A CAR DO THAT WITHOUT THE TRANY BEING BAD. WHEN STOPED AT A LIGHT THE TRANY TAKES A COUPLE OF SECONDS TO REENGAGE FOR TAKE OFF. TFS REPEATED PROBLEMS NOT WORKING POPERLY, THE CARS HANDLING IS VERY POOR IN THE RAIN,SNOW,OR ICE. THE MUFFLER SYSTEM HAS A LEAK AS WELL.

Make : CHEVROLET **Model :** IMPALA **Year :** 2007
Manufacturer : GENERAL MOTORS LLC
Crash : No **Fire :** No **Number of Injuries :** 0
ODI ID Number : 10291439 **Number of Deaths :** 0
Date of Failure: October 31, 2009
VIN : 2G1WB58K079...
Component: SUSPENSION

Summary:
 I OWN A 2007 CHEVROLET IMPALA LS. FOR SOME REASON, THERE IS A CLUNK/KNOCK IN WHEN I STEER TO THE RIGHT. AT TIMES IT HAS A TENDENCY TO LOCK UP. ALSO, THERE IS A STRONG VIBRATION THAT OCCURS WHEN I AM DOING 35 MPH OR FASTER. I DO NOT FEEL SAFE. *TR

Make : CHEVROLET **Model :** IMPALA **Year :** 2007
Manufacturer : GENERAL MOTORS LLC
Crash : No **Fire :** No **Number of Injuries :** 0
ODI ID Number : 10282425 **Number of Deaths :** 0
Date of Failure: August 28, 2008
VIN : 2G1WT55N879...
Component: SUSPENSION

Summary:
 ALL 4 WHEELS ARE OUT OF ALIGNMENT CAUSING EXCESSIVE WEAR ON THE INSIDE OF ALL 4 TIRES. I BOUGHT THE VEHICLE 2 YEARS AGO AND IT HAD ONLY 14000 MILES. I BELIEVE IT WAS A RENTAL VEHICLE. I NOW HAVE TO REPLACE ALL 4 TIRES AND GET A 4 WHEEL ALIGNMENT DONE. I BELIEVE THE PROBLEM WAS CAUSED BY THE ORIGINAL MANUFACTURER (POOR QUALITY CONTROL). THE DEALER SAID IT WAS CAUSED BY THE BRAND OF TIRE ON THE VEHICLE WHICH IS NONSENSE. *TR

Make : CHEVROLET **Model :** IMPALA **Year :** 2007
Manufacturer : GENERAL MOTORS LLC
Crash : No **Fire :** No **Number of Injuries :** 0
ODI ID Number : 10255330 **Number of Deaths :** 0
Date of Failure: January 13, 2009
VIN : Not Available
Component: SUSPENSION

Summary:
 MY 2007 CHEVY IMPALA HANDLES POORLY IN SNOW CONDITIONS. DIFFICULT TO CONTROL THE BACK END. I MADE A LEFT TURN AFTER BEING STOPPED AT A STOP LIGHT GOING APPROXIMATELY 5 - 10 MPH AND BACK END CONTINUED THE TURN AND CAR SPUN 180 DEGREES. WENT TO AN INTERNET DISCUSSION BOARD AND NOTICED I'M NOT THE ONLY DRIVER EXPERIENCING PROBLEM. [HTTP://WWW.TOPIX.COM/FORUM/AUTOS/CHEVROLET-IMPALA/T2BLGNEG9LDGO6Q81](http://www.toPIX.com/forum/autos/chevrolet-impala/t2BLGNEG9LDGO6Q81). *TR

Make : CHEVROLET **Model :** IMPALA **Year :** 2007
Manufacturer : GENERAL MOTORS LLC
Crash : No **Fire :** No **Number of Injuries :** 0
ODI ID Number : 10251393 **Number of Deaths :** 0
Date of Failure: December 9, 2008
VIN : 2G1WC58R079...
Component: SUSPENSION

Summary:
 I PURCHASED 2007 CHEVY IMPALA WITH 32,000 MILES. I BOUGHT THIS AT A GM AUTHORIZED DEALER. HOW CAN THEY SELL A CAR WITH AN ALIGNMENT ISSUE. AT 40,000 MILES THE INSIDE OF THE REAR TIRES ARE ALMOST BALD. I CALLED GM AN GOT A CASE NUMBER OF 71-686232146 THEY STATED THAT I WOULD HAVE TO GO AND PAY A DEALERSHIP \$100 TO DO A DIAGNOSTIC ON THE CAR AND THEY WOULD THEN AT THAT TIME DO A REVIEW IF THEY WOULD COVER THE REPAIRS OR NOT. UPON RESEARCHING ON THE INTERNET I HAVE FOUND SEVERAL OTHER PEOPLE WITH THE SAME PROBLEM ON THIS CAR. GM IS ADMITTING THIS IS A PROBLEM ON THE POLICE VERSION OF THE CAR. THE PART NUMBERS FOR THE SPINDLE ROD IS THE SAME ON BOTH CARS. I BELIEVE GM ISN'T FIXING CIVILIAN CARS DUE TO WE DONT HAVE UNLIMITED MONEY AND LAWYERS LIKE THE CITY, STATE AND GOVERNMENT. I NOTICED THIS ON TUESDAY DECEMBER 9TH 2008 ON AN ICY ROAD. AT 30 MPH, IT FEELS LIKE THE REAR END WANTS TO PASS YOU OR LIKE AS IF YOU WERE PULLING A TRAILER THAT WAS VIOLENTLY WIPING BACK AND FORTH. WHEN I WENT FROM DRY PAVEMENT TO ICY PAVEMENT THE CAR WENT SIDEWAYS. I HAD MADE AN APPOINTMENT WITH COUNTRY SIDE MOTORS IN WELLINGTON KANSAS 67152 PHONE 620-328-7433 AND SPOKE WITH THE SERVICE MANAGER RON. WE MADE AN APPOINTMENT FOR THE NEXT DAY. HE CALLED ME BACK 15 MINUTES LATER AFTER LOOKING AT THE RECALL FOR THE POLICE VERSION AND SAID HE DIDN'T LIKE MY ATTITUDE THE LAST TIME WE TALKED ON A DIFFERENT ISSUE "IT WAS ABOUT THE TIRE PRESSURE MONITORING SYSTEM BEING OFF, HE SAID MY TIRE WERE OVER INFLATED AND TO NOT GO BY WHAT THE TIRE MANUFACTURER SAYS BUT GO BY WHAT GM SAYS TO INFLATE TO. I TOLD HIM NOT SO AND AN EXAMPLE OF IT WAS FORD ALSO THOUGHT THEY KNEW BETTER THAN THE TIRE

COMPANIES AND THEY WERE WRONG TOO." SO HE TOLD ME THAT COUNTRY SIDE WAS WASHING THEIR HANDS OF ME AND MY ISSUES AND HUNG UP THE PHONE. I BELIEVE THIS TO BE A SERIOUS SAFETY ISSUE WITH THE CAR. A PERSON COULD INVOLUNTARILY SWERVE AND HIT AN ONCOMING CAR. THE PARTS ARE \$250.00 PLUS INSTALL AND NEW TIRES. *TR

Make : CHEVROLET **Model :** IMPALA **Year :** 2007
Manufacturer : GENERAL MOTORS LLC
Crash : No **Fire :** No **Number of Injuries:** 0
ODI ID Number : 10238484 **Number of Deaths:** 0
Date of Failure: August 14, 2008
VIN : Not Available
Component: SUSPENSION

Summary:

RECALL FROM CHEVY2007 IMPALA ON REAR ALIGNMENT PROBLEM AND IT WAS BROUGHT IN AND THE RECALL WAS DONE. SINCE THE VEHICLE CAME BACK FROM THE RECALL THE REAR END IS SWAYING TO THE LEFT AND RIGHT. THIS SEEMS TO HAPPEN IF YOU HIT A BUMP IN THE ROAD. THIS PROBLEM WAS BROUGHT TO THE ATTENTION OF THE DEALERSHIP WHO DID AGREE THAT IT IS DOING THIS. THE CHECKED EVERYTHING AND NOTHING WAS LOOSE. THEY CHECKED WITH I BELIEVE FACTORY WHO HAVE NO ANSWER. *TR

Make : CHEVROLET **Model :** IMPALA **Year :** 2007
Manufacturer : GENERAL MOTORS LLC
Crash : No **Fire :** No **Number of Injuries:** 0
ODI ID Number : 10225384 **Number of Deaths:** 0
Date of Failure: July 21, 2007
VIN : 2G1WB58K179...
Component: SUSPENSION

Summary:

TL*THE CONTACT OWNS A 2007 CHEVROLET IMPALA. A FEW DAYS AFTER THE VEHICLE WAS PURCHASED, IT BEGAN TO VIBRATE WHEN DRIVING BETWEEN 35-55 MPH. THE CONTACT TOOK THE VEHICLE BACK TO THE DEALER AND THEY REPAIRED THE TIRE MONITOR. THREE WEEKS LATER, THE FAILURE RECURRED AND THE DEALER REPLACED AN AXLE. THE VEHICLE IS STILL NOT WORKING PROPERLY. THE FAILURE MILEAGE WAS 1,000 AND CURRENT MILEAGE WAS 23,348.

Make : CHEVROLET **Model :** IMPALA **Year :** 2007
Manufacturer : GENERAL MOTORS LLC
Crash : No **Fire :** No **Number of Injuries:** 0
ODI ID Number : 10219953 **Number of Deaths:** 0
Date of Failure: February 25, 2008
VIN : 2G1WS55R379...
Component: SUSPENSION

Summary:

REAR ALIGNMENT NOT WITHIN SPECS FROM FACTORY, CAUSED REAR TIRES TO WEAR PREMATURELY. FRONT DISC BRAKES NEEDED REPLACEMENT 11,000 MILES AND ROTORS NEEDED TO BE RESURFACED. CHEVY WOULD NOT COVER THE REPAIRS UNDER WARRANTY. *TR

1200 New Jersey Avenue, SE, West Building Washington DC 20590 USA
 1.888.327.4236 TTY 1.800.424.9153





Complaints - Search Results

4 Record(s) Displayed.

Report Date : July 22, 2012 at 04:11 PM
 Search Type : VEHICLE
 Year : 2007
 Make : CHEVROLET
 Model : IMPALA

Make : CHEVROLET **Model :** IMPALA **Year :** 2007
Manufacturer : GENERAL MOTORS LLC
Crash : No **Fire :** No **Number of Injuries :** 0
ODI ID Number : 10370379 **Number of Deaths :** 0
Date of Failure: December 10, 2010
VIN : Not Available
Component: STRUCTURE:FRAME AND MEMBERS

Summary:

2007 IMPALA DRIVERS DOOR HANDLE BROKE UNDER NORMAL USAGE AND WAS REPAIRED UNDER EXTENDED WARRANTY BUT CAR HAS ONLY 70000 MILES. ALSO THE REAR TIRES ARE WEARING OUT FAST AND UNUSUAL WEAR ON THE INSIDE EDGES. THIS WEEKEND HAD TO REPLACE TIRES AGAIN SINCE STEEL BELTS WERE SHOWING AND LOCAL SHOP IS STATING THEY SEE THIS ALL THE TIME ON IMPALAS. I HAVE RESEARCHED ON LINE AND SEE MANY COMPLAINTS BUT NO RECALL FROM GM. *TR

Make : CHEVROLET **Model :** IMPALA **Year :** 2007
Manufacturer : GENERAL MOTORS LLC
Crash : No **Fire :** No **Number of Injuries :** 0
ODI ID Number : 10359246 **Number of Deaths :** 0
Date of Failure: October 5, 2010
VIN : 2G1WB58K179...
Component: STRUCTURE:FRAME AND MEMBERS

Summary:

HAD CLUNK NOISE COMING FROM REAR SUSPENSION WHEN GOING OVER EVEN THE SMALLEST BUMP OR CRACK IN THE ROAD. TOOK BACK TO DEALER AND THEY FOUND THE CROSS MEMBERS OF THE CHASSIS - BOLTS HAD WORKED LOOSE. THEY TIGHTENED THEM. NO MORE NOISE SO FAR. *TR

Make : CHEVROLET **Model :** IMPALA **Year :** 2007
Manufacturer : GENERAL MOTORS LLC
Crash : No **Fire :** No **Number of Injuries :** 0
ODI ID Number : 10284862 **Number of Deaths :** 0
Date of Failure: November 14, 2008
VIN : 2G1WC58R679...
Component: STRUCTURE:FRAME AND MEMBERS

Summary:

I BOUGHT A NEW 2007 CHEVY IMPALA IN MAY 2007. HAD TO HAVE NEW TIRES IN NOVEMBER 2008 AT 14500 MILES. THEY WERE WEARING ON THE INSIDE OF THE REAR TIRES AFTER WE ROTATED THE TIRES THE FRONT PUT ON THE BACK THEY WORE ON THE INSIDE ALSO. THE WOULD ONLY PUT TIRES ON AND WE HAD TO PAY FOR TWO TIRES. HAD ALIGNMENTS, DID NOT HELP. CANT GET ANYTHING DONE ABOUT THIS. IT IS IN THE SUSPENSION OR SOMETHING IN THE REAR. THEY ARE WEARING AGAIN AT 22,000 MILES. I DONT UNDERSTAND WHY THEY CAN NOT FIX MY CAR IT IS STILL UNDER WARRANTY. THEY CAN OFFER THE 60 MONTH RETURN ON THEIR VEHICLES IF YOU DO NOT LIKE IT NOW, BUT CANNOT HONOR WHAT IS WRONG WITH MY CAR. THIS IS WRONG. YOU SHOULD MAKE THEM FIX ALL THE CARS WITH THIS PROBLEM. THE CONSUMER IS SUPPOSE TO BE PART OWNER IN THE CAR BUSINESS BUT IT STILL DOES NOT MAKE ANY DIFFERENCE. LET THEM GO UNDER. THEY ARE NOT WORTH ANYTHING ANYWAYS. USED TO BE A GOOD CAR COMPANY. WE HAVE OWNED A LOT OF THEIR CARS, BUT NO MORE. IF I EVER CAN AFFORD TO TRADE AGAIN IT WILL NOT BE A GM PRODUCT. THE CONSUMER MEANS NOTHING TO THEM ANYMORE. *TR

Make : CHEVROLET **Model :** IMPALA **Year :** 2007

Manufacturer : GENERAL MOTORS LLC

Crash : No

Fire : No

Number of Injuries: 0

ODI ID Number : 10279812

Number of Deaths: 0

Date of Failure: October 16, 2008

VIN : 2G1WC58R079...

Component: STRUCTURE:FRAME AND MEMBERS

Summary:

2008 & 2007 CHEVROLET IMPALAS. WE PURCHASED A 2007 IMPALA FROM CHARLES CHEVROLET-COLOMA, WISCONSIN IN JUNE OF 2008. IT HAD 17,000 MILES ON IT AND THE REMAINING NEW CAR WARRANTY. WE WERE TOLD. RIGHT AWAY WHEN WE GOT IT WE DIDN'T THINK IT RODE GOOD. WE TOOK IT ON VACATION IN OCTOBER AND IT STARTED TO VIBRATE VERY BAD. MY HUSBAND COMMENTED THAT WHEN WE GET BACK WE NEED TO TAKE IT IN. WE TOOK IT IN IN OCTOBER OF 2008. WE WERE TOLD THAT THE TIRES ON THE BACK OF THE VEHICLE WERE HANGING ON THREADS. THE DEALER DID REPLACE THE TIRES. AT THAT TIME WE THOUGHT WELL MAYBE A BAD SET OF TIRES. AT THAT TIME THE DEALER DID NOT BALANCE OR LINE UP THE TIRES. (WHICH THEY SHOULD HAVE) WE HAVE BEEN WATCHING THE TIRES AND NOW AT 35,000.00 MILES THE VEHICLE NEEDS NEW TIRES AGAIN. IT RIDES REALLY BAD AGAIN. WE TOOK IT IN AGAIN AND FIRST THE DEALER, LINES IT UP, IT STILL DID NOT RIDE GOOD, THEN THEY BALANCED THE FRONT TIRES (NOT THE BACK AND I DONT KNOW WHY???) I GUESS BECAUSE THEY ARE DOING THIS AT THEIR COST AND DONT WANT TO DO ANYTHING MORE THAN THEY HAVE TO. IT STILL DOES NOT RIDE WELL. I WORK IN A BANK AND AFTER TALKING TO ANOTHER PERSON THEY HAVE PUT 3 SETS OF TIRES ON THEIRS IN 60,000 MILES. ANOTHER PERSON HAS 35,000 MILES ON THEIR BRAND NEW 2008 AND THEY NEED NEW TIRES. AFTER BRINGING THIS TO THE ATTENTION OF THE DEALER THEY SAID THEY HAVE HAD NUMEROUS CARS IN WITH THIS PROBLEM. THEY WILL NOT DO ANYTHING ELSE FOR US. I CONTACTED GENERAL MOTORS AND THEY ALSO WILL NOT DO ANYTHING. THIS VEHICLE HAS A 100,000 MILE WARRANTY ON THE DRIVE TRAIN. MY CONCERN IS THAT THERE IS A DEFECT IN THESE VEHICLES THAT PROPOSES A SAFETY HAZARD. SOME UNSUSPECTING CONSUMER WILL HAVE A BLOWOUT (LIKE WE ALMOST DID) AND LOSE THEIR LIFE. THERE SHOULD BE A RECALL ON THESE VEHICLES. THIS REALLY MAKES US ANGRY AS THE GOVERNMENT CAN GIVE GENERAL MOTORS ALL THIS BAILOUT MONEY , BUT THEY DONT HAVE TO STAND BEHIND THEIR PRODUCT!!!! THE DEALER REFUSES TO GIVE US A RECORD OF THE TIRE REPLACEMENT. *TR

1200 New Jersey Avenue, SE, West Building Washington DC 20590 USA
1.888.327.4236 TTY 1.800.424.9153





Complaints - Search Results

8 Record(s) Displayed.

Report Date : July 22, 2012 at 04:06 PM

Search Type : VEHICLE

Year : 2007

Make : CHEVROLET

Model : IMPALA

Make : CHEVROLET **Model :** IMPALA **Year :** 2007
Manufacturer : GENERAL MOTORS LLC
Crash : No **Fire :** No **Number of Injuries :** 0
ODI ID Number : 10458955 **Number of Deaths :** 0
Date of Failure: May 7, 2012
VIN : Not Available
Component: TRACTION CONTROL SYSTEM

Summary:

MY IMPALA'S SERVICE TRACTION CONTROL AND ENGINE POWER REDUCED LIGHTS CAME ON 05/07/12 AND I LOSS POWER TO MY CAR. I TOOK MY CAR IN TO A CHEVY DEALERSHIP TO HAVE IT SERVICED, I WAS TOLD AFTER THEY DIAGNOSED IT THAT I NEEDED A NEW THROTTLE BODY SO I HAD IT REPLACED FOR THE COST OF \$647.00 1 WEEK LATER I WAS DRIVING HOME AND MY CAR LOSS POWER AND SHUTDOWN COMPLETELY LUCKILY I WASNT IN HEAVY TRAFFIC AND WAS ABLE TO PULL OVER TO THE SIDE OF THE ROAD. I TRIED TO RESTART IT AND WHITE SMOKE CAME FROM THE TAILPIPE SO I HAD IT TOWED BACK TO THE SAME DEALERSHIP THEY TOLD ME AFTER LOOKING @ IT THAT NOW I NEEDED A NEW ENGINE WHICH WOULD COST ME \$6200 I DIDNT GET ANY LIGHTS ON THE DASHBOARD OR ANY OTHER INDICATION THAT I WAS HAVING ENGINE TROUBLE AND THEY CANT TELL ME WHY IT HAPPENED. I HAVE MY CAR SERVICED LIKE CLOCKWORK @ THE DEALERSHIP SPENDING GOOD MONEY FOR SUPPOSEDLY GOOD QUALITY SERVICE INSTEAD OF SOME RINKY DINK GARAGE BUT I GUESS THAT DIDNT MATTER. THIS HAPPENED JUST AFTER WARRANTY EXPIRED, I HAVE 9100 MILES AND 3 CAR PAYMENTS LEFT. *TR

Make : CHEVROLET **Model :** IMPALA **Year :** 2007
Manufacturer : GENERAL MOTORS LLC
Crash : No **Fire :** No **Number of Injuries :** 0
ODI ID Number : 10457831 **Number of Deaths :** 0
Date of Failure: March 30, 2012
VIN : 2G1WC58R679...
Component: TRACTION CONTROL SYSTEM

Summary:

INTERMITTENT PROBLEMS WITH "SERVICE TRACTION CONTROL" AND "ENGINE POWER REDUCED". MY IMPALA IS STARTING TO RUMBLE AND JOSTLE WHEN THESE WARNINGS APPEAR. HOWEVER, I CANT FIGURE OUT THE REASON. *TR

Make : CHEVROLET **Model :** IMPALA **Year :** 2007
Manufacturer : GENERAL MOTORS LLC
Crash : No **Fire :** No **Number of Injuries :** 0
ODI ID Number : 10414873 **Number of Deaths :** 0
Date of Failure: July 20, 2011
VIN : 2G1WD58C079...
Component: TRACTION CONTROL SYSTEM

Summary:

WE PURCHASED OUR 2007 IMPALA SS ON 11/17/09 WITH 33,003 MILES ON IT. ON JULY 20, 2011 WHILE DRIVING HOME FROM WORK WITH MY WIFE AND STEPSON ON THE I-94 FREEWAY IN CLINTON TOWNSHIP, MI., THE LEFTSIDE REAR TIRE BLEWOUT. WE NOTICE THAT IT HAD BROKE THE INNER PLASTIC PIECE AND BENT THE MUFFLER TIP AND THERE WAS CLEARLY NO RUBBER LEFT ON THE INSIDE OF THE TIRE ALL YOU SAW WAS WIRES. HAD TO PUT OUR SPARE TIRE ON. TOOK THE CAR INTO THE TIRE SHOP ON JULY 22, 2011 TO HAVE THAT TIRE REPLACED. SERVICE GUY SAID THERE WAS NO RUBBER LEFT ON THE INSIDE OF THE LEFT TIRE IN THE REAR, AND THE WIRES WERE CLEARLY VISIBLE AND SHOWED US THEM, WHICH WE HAD NOTICED WHEN THIS OCCURRED. HE ALSO STATED THAT ON THE REAR RIGHTSIDE THE WIRES WERE SHOWING TOO. WE HAD HIM REPLACE ALL 4 TIRES ON THE VEHICLE. HE ALSO STATED THAT WE HAD BEEN THE 4TH IMPALA THEY HAD REPLACED TIRES ON IN THE

PAST WEEK. WHILE ON THE LIFT WE NOTICED THAT THE BACK TIRES WERE SLIGHTLY LEANING OUT, LIKE (1) LEFT SIDE AND (1) RIGHT SIDE, I TOLD HIM THAT I WANT THE TIRES BACK AND HE GAVE THEM TO ME. WE TOOK THEM HOME AND TOOK PICKS OF THEM AND THE BACK OF OUR CAR TO SHOW HOW THE TIRES WERE STILL LEANING OUT, AND ALSO TOOK PICTURES OF WHERE THE PLASTIC HAD BEEN BROKE IN THE WHEEL WELL. THIS HAS HAPPENED IN LESS THAN 20,000 MILE SINCE WE PURCHASED THE VEHICLE. I WENT TO THE DEALERSHIP THAT WE PURCHASED THE VEHICLE FROM AND TOLD THE SERVICE GUY WHAT HAD HAPPENED, HE STATED THAT THERE WAS NO RECALL AS OF YET ON THIS PROBLEM BUT THAT OTHER PEOPLE HAD CAME IN WITH THE SAME COMPLAINTS, THAT I SHOULD GET AHOLD OF GM AND SEE WHAT THEY SAY. HE TOLD ME THAT HE WAS AWARE OF THE POLICE VEHICLE THAT HAD BEEN RECALLED BUT AS OF YET KNEW NOTHING ABOUT ALL OTHERS. HE STATED THAT HE WISHED HE COULD DO SOMETHING FOR US BUT THERE WAS NOTHING HE COULD DO. WHEN IS GM GONNA DO SOMETHING ABOUT THIS? *TR

Make : CHEVROLET **Model :** IMPALA **Year :** 2007
Manufacturer : GENERAL MOTORS LLC
Crash : No **Fire :** No **Number of Injuries:** 0
ODI ID Number : 10373190 **Number of Deaths:** 0
Date of Failure: December 28, 2010
VIN : 2G1WT58N079...

Component: TRACTION CONTROL SYSTEM

Summary:

THE 2007 CHEVROLET IMPALA IS AN EXTREMELY UNSAFE AUTOMOBILE IN WET OR SNOW/ICE CONDITIONS, EVEN SAND OR SALT; THIS CAR IS THE WORST HANDLING AUTOMOBILE POSSIBLY EVER DESIGNED BY GM. THE IMPALA'S REAR END SLIDES LEFT OR RIGHT WITH ONLY A MINIMAL AMOUNT OF DEBRIS, WATER, OR SNOW ON THE ROAD. THIS IS NOT JUST A LITTLE SLIP NOW AND AGAIN, IT IS UNCONTROLLABLE AND AN EXTREME SAFETY HAZARD. EVERY PERSON THAT HAS HAD ANY DEALINGS WITH THIS TYPE OF CAR WILL TELL YOU THE SAME THING. ASK ANY MECHANIC, DEALERSHIP, TIRE SALES REP, AND MOST OF ALL, A 2007 CHEVY IMPALA OWNER AND ALL WILL ATTEST TO THE POOR DESIGN OF THIS CAR. MY WIFE AND I WILL NOT, OR SHOULD SAY CANNOT, DRIVE THIS CAR WHEN THERE IS ANY SIGN OF RAIN OR SNOW IN THE FORECAST. SOMETHING MUST BE DONE ABOUT THIS CAR. NOT ONLY IS THERE A HANDLING PROBLEM, BUT TIRE WEAR IS ALMOST UNBELIEVABLE. THE ALIGNMENT SPECIFICATIONS ARE AT SUCH EXTREMES THAT TIRES ARE RUINED IN 10,000 MILES OR LESS. WHEN LOOKING AT THE CAR FROM THE REAR, THE IMPALA'S WHEELS TILT IN TO THE POINT IT LOOKS AS THOUGH THEY COULD COLLAPSE INWARD UNDER THE CAR. I HAVE HAD THE DEALERSHIP AND TWO DIFFERENT ALIGNMENT SHOPS CHECK THE ALIGNMENT AND ALL SAY THE SAME; THE CAR IS WITHIN SPECS AND TO BE EXTRA CAREFUL AS THAT THE HANDLING OF THESE CARS ARE UNSAFE. WHAT GIVES? DOES IT TAKE A FATALITY TO OCCUR BEFORE GM WILL DO ANYTHING ABOUT THIS DESIGN FLAW? PLEASE LOOK INTO THIS MATTER, LIVES DEPEND ON IT. ANYONE, AND I MEAN ANYONE, WHO DRIVES THIS CAR CANNOT DENY THERE IS SOMETHING SERIOUSLY WRONG THE 2007 CHEVROLET IMPALA. A FINAL NOTE, IT WAS BROUGHT TO MY ATTENTION THAT ALL POLICE CARS OF THIS TYPE WERE RECALLED FOR THIS VERY PROBLEM, IS THAT INDEED THE CASE? IF SO, WHAT ABOUT MY FAMILY'S SAFETY AND EVERY OTHER FAMILY THAT OWNS ONE OF THESE CARS? DO WE NOT DESERVE THE SAME PROTECTION? *TR

Make : CHEVROLET **Model :** IMPALA **Year :** 2007
Manufacturer : GENERAL MOTORS LLC
Crash : No **Fire :** No **Number of Injuries:** 0
ODI ID Number : 10369185 **Number of Deaths:** 0
Date of Failure: December 12, 2007
VIN : 2G1WC58R479...

Component: TRACTION CONTROL SYSTEM

Summary:

2007 CHEVY IMPALA ABSOLUTELY SUCKS ON ANY AMOUNT OF SNOW. REAR END FISHTAILS LEFT AND RIGHT AS IF IT HAS A MIND OF IT'S OWN. ABSOLUTELY RIDICULOUS AND UNSAFE!! *TR

Make : CHEVROLET **Model :** IMPALA **Year :** 2007
Manufacturer : GENERAL MOTORS LLC
Crash : No **Fire :** No **Number of Injuries:** 0
ODI ID Number : 10368219 **Number of Deaths:** 0
Date of Failure: September 30, 2010
VIN : 2G1WC58R479...

Component: TRACTION CONTROL SYSTEM

Summary:

TL*THE CONTACT OWNS A 2007 CHEVROLET IMPALA 3LT(NA). THE CONTACT STATED THAT WHILE DRIVING THE VEHICLE FROM A STOP LIGHT OR STOP SIGN, THE TIRES SPUN OUT AND THE TRACTION CONTROL LIGHT ILLUMINATED ON THE INSTRUMENT PANEL. THE FAILURE OCCURRED INTERMITTENTLY. THE VEHICLE WAS TAKEN TO AN AUTHORIZED DEALER BUT THE FAILURE COULD NOT BE DUPLICATED. THE VEHICLE HAD NOT BEEN REPAIRED. THE FAILURE MILEAGE WAS 6.

Make : CHEVROLET **Model :** IMPALA **Year :** 2007
Manufacturer : GENERAL MOTORS LLC
Crash : No **Fire :** No **Number of Injuries:** 0
ODI ID Number : 10340782 **Number of Deaths:** 0
Date of Failure: June 1, 2010
VIN : 2G1WT58K679...
Component: TRACTION CONTROL SYSTEM

Summary:

ABS & TRACTION CONTROL SERVICE LIGHT KEPT COMING ON AND I TOOK IT TO DEALERSHIP FOR SERVICE AND THEY TOLD ME IT WAS THE HUB ASSEMBLY FOR THE LEFT SIDE DRIVER SIDE THAT WAS COVERED UNDER WARRANTY AND THAT I NEEDED TO REPLACE MY FRONT ROTORS AND BRAKE PADS (I WASN'T HAVING ANY PROBLEMS WITH MY BRAKES BUT BECAUSE THEY SAID THEY NEEDED REPLACING I WENT ALONG WITH IT). AFTER REPAIRS WERE COMPLETED AND MY VEHICLE "ROAD-TESTED", I PICKED UP MY CAR AND AFTER LEAVING THE DEALERSHIP, BOTH THE ABS AND TRACTION SERVICE LIGHT CAME ON AGAIN AND I CALLED AND THEY SCHEDULED ME IN FOR AN APPT. 2 DAYS LATER. THEY COULDN'T FIND THE PROBLEM SO THEY CALLED AND TOLD ME THAT THEY NEEDED TO DIG DEEPER AND KEEP MY CAR OVERNIGHT AND THAT I WOULD NOW BE CHARGED A DIAGNOSTIC FEE TO DIAGNOSE THE PROBLEM UP TO \$100. MY SERVICE 2 DAYS PRIOR COST \$224.90 SO I WAS A LITTLE SKEPTICAL BUT I NEEDED TO KNOW WHAT THE PROBLEM WAS SO I AGREED. I RECEIVE A PHONE CALL TODAY STATING THAT IT IS A WIRE IN THE HARNESS THAT'S CAUSING THE PROBLEM AND IT WOULD BE ANOTHER \$250.00 TO FIX. I CHECK THE INTERNET TO FIND OUT MORE INFORMATION AND NOT ONLY HAS THIS HAPPENED TO ME BUT TO SEVERAL OTHERS AND OBVIOUSLY THIS IS A MANUFACTURER DEFECT AND SHOULD BE COVERED AND HOW DO I KNOW THAT THE DEALERSHIP DIDN'T CAUSE THE PROBLEM/DEFECT BY DIGGING DEEPER TO FIND OUT WHY THE SERVICE LIGHTS WERE COMING ON AND DAMAGED THE WIRE.

*TR

Make : CHEVROLET **Model :** IMPALA **Year :** 2007
Manufacturer : GENERAL MOTORS LLC
Crash : No **Fire :** No **Number of Injuries:** 0
ODI ID Number : 10322480 **Number of Deaths:** 0
Date of Failure: December 29, 2009
VIN : 2G1WU58R079...
Component: TRACTION CONTROL SYSTEM

Summary:

1. CONSTANT FISHTALING WHEN DRIVING 2. SINCE VEHICLE WAS PURCHASED 3. REPAIRED BY QUALIFIED AUTO REPAIR SHOP, SINCE NO GM DEALER NEARBY.

1200 New Jersey Avenue, SE, West Building Washington DC 20590 USA
 1.888.327.4236 TTY 1.800.424.9153



Houston, TX
U.S.A.

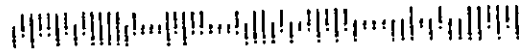

U.S. POSTAGE
PAID
SPRING, TX
77388
JUL 30, 12
AMOUNT

\$3.10
00058952-05

David Strickland
NHTSA
1200 New Jersey Ave SE West bldg.
Washington, DC 20590