

INFORMATION Redacted PURSUANT TO THE FREEDOM OF
INFORMATION ACT (FOIA), 5 U.S.C . 552(B)(6)

9

August 25, 2011

AUG 31 2011

N.H.T.S.A.
1200 New Jersey Ave.
SE, West Building
Washington, DC 20590

CL-10427308-9841

Dear Sirs:

I am writing to file a complaint against Honda Motor Company. Honda is aware that they have a defective part in their rear motor mounts on the 2006 Honda Odyssey. Instead of correcting the problem they are passing the cost onto the consumer. Enclosed are documents including the service bulletin #06-083 regarding the rear motor mounts. I started complaining to my dealership about the vibration of the van in July 2007. Well after the service bulletin. Despite several trips to the dealership without fully getting the problem resolved the rear motor mounts were never looked at until the van was out of warranty. I was then told that it would cost over \$800 to repair a problem that Honda was well aware of and the dealership didn't check until the van was out of warranty.

I asked for goodwill consideration to have the part repaired, only to be refused by the dealership and Honda Motor Company.

Honda Motor Company is deceiving the American consumer by not addressing this issue with a nationwide recall or at least looking at the motor mounts to get them repaired while the vehicle is still under warranty. They also charged us \$26 to untwist the passenger side seat belt, saying they just don't twist themselves so it must be our fault. Two weeks later after limited use the seat belt is twisted again. I have spent hours of my own time not to mention gas going to my dealership hoping to get quality Honda service. My experience has been once your van is out of warranty Honda treats you like a second class citizen.

Any assistance you could provide in this matter would be greatly appreciated.

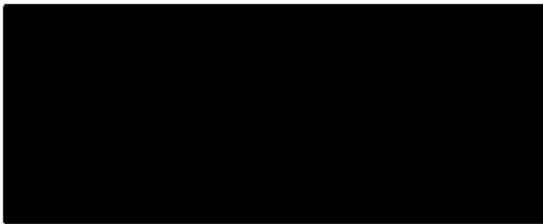

Cc: American Honda Motor Co.

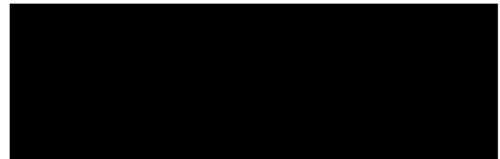

Monroe City, mo



Search AGO

[AGO Home](#)
[Home](#)
[AGO Employment Opportunities](#)
[AG Koster's Bio / Download Official Portrait](#)
[AGO by Division](#)
[News](#)
[FAQs](#)
[Forms](#)
[Search ago.mo.gov](#)
[Jobs](#)
[Open Meetings](#)
[Search Opinions](#)
[Contact Us](#)
[Agriculture & Environment](#)
[Agriculture & Environment Front Page](#)
[Environmental Protection](#)
[Missouri River](#)
[Consumer Protection](#)
[Consumer Protection Front Page](#)
[Consumer Corner](#)
[Blog](#)
[Calculators](#)
[Encyclopedia](#)
[Publications](#)
[Quizzes](#)
[Consumer Programs](#)
[Check a Charity](#)
[Consumer Complaints](#)
[Identity Theft](#)
[Know MO](#)
[No Call List](#)
[Business registrations](#)
[Law Enforcement](#)
[Law Enforcement Front Page](#)
[Concealed Carry Reciprocity](#)
[Crime Victims](#)
[State & Local Law](#)
[Vehicle Stops Report](#)
[Prosecuting Attorneys](#)
[MOPS](#)
[Tobacco](#)
[Sunshine Law](#)
[Missouri's Sunshine Law Front Page](#)
[File a Sunshine Law Complaint](#)
[Request a Sunshine Law Speaker](#)



Missouri Attorney General

Consumer Protection

- [Consumer Protection Front Page](#)
- [Consumer Corner](#)
 - [Blog](#)
 - [Calculators](#)
 - [Encyclopedia](#)
 - [Publications](#)
 - [Quizzes](#)
- [Consumer Programs](#)
 - [Check-a-Charity](#)
 - [Consumer Complaints](#)
 - [Identity Theft](#)
 - [Know MO](#)
 - [No Call](#)
- [Recalls](#)

Consumer Complaints

Your consumer complaint was successfully submitted to the Attorney General's Consumer Protection Division.

Thank you.

This is your receipt. Please print this page for your records.

To file another consumer complaint with the Attorney General's Office, [click here](#).

Confirmation Details

Confirmation Number: 440214
Confirmation Time: 2011-08-15 11:56:40

Your Contact Information

Name: [REDACTED]
Address: Monroe City MO [REDACTED]
County: Monroe
Email: [REDACTED]
Home Phone: [REDACTED]
Work Phone: -

Information About Company that Complaint is Against

Name of Company: Corwin Honda
Phone: 573-893-7676
Address: 3215 Missouri Blvd.
Jefferson City MO 65109
County: Cole
Web Site: www.hondajeffercity.com
Email:
Contact's Name: Dan Robbass
Contact's Title: Service Manager

Details of Transaction

Date of Transaction: Jul 08 2011
Amount of Transaction: 26.85
Payment Method: Credit Card

Details of Complaint

How and where did you learn about product or service?

Recall Service

Description of Complaint:

Above complaint is regarding getting charged \$26.95 for them to untwist the passenger seat belt. The claimed they just don't twist themselves so it must be operator error. No regard for safety, just want to make a buck. The main complaint is over the rear motor mounts which are going bad on Honda Odyssey mini vans and is a known problem and Honda knows about it and has a technical service bulletin 06-083 dated December 1, 2006. I complained about the vibration of the van back in July, 2007 while the van was still under warranty. They never checked the rear motor mounts. Now that the van is out of warranty they tell me the motor mounts are bad and want \$1000 to repair. Thousands of Honda owners are getting the same run a round from Honda and the dealerships. A nationwide recall should be demanded of Honda for premature failures of the rear motor mounts and they should be investigated for fraudulent business practices and deceiving the consumer and not honoring their warranty.

Did you sign a contract, warranty agreement or similar papers?

No

What action have you taken to resolve this complaint?

Taken the van in numerous times

Name of any agency contacted:

Reagan Honda and then Coinm Honda

Have you been sued or filed a lawsuit about this complaint?

No

How do you want this complaint resolved?

Repair

If you answered "Other" to the previous question, please specify

[AGO en español](#) | [State homepage](#) | [Missouri statutes](#) | [Forms](#) | [Help](#) | [Site Map](#) | [RSS](#) | [Accessibility](#) | [Privacy Policy](#) | [Contact Us](#)



Applies To: 2005-06 Odyssey EX-L - ALL
2005-06 Odyssey Touring - ALL

December 1, 2006

Excessive Engine Vibration at Idle or Below 2,100 RPM

SYMPTOM

The engine vibrates excessively at idle or, under load, up to about 2,100 rpm.

PROBABLE CAUSE

The rubber inside the rear engine mount is torn.

CORRECTIVE ACTION

Replace the rear engine mount and its mounting bolts.

PARTS INFORMATION

Rear Engine Mount:

P/N 50810-SHJ-A62, H/C 8485906

Rear Engine Mount Bolt, 10 x 35:

P/N 90163-SDA-A01, H/C 7151350

Rear Engine Mount Bolt, 10 x 20 (four required):

P/N 90163-S5A-000, H/C 6462931

WARRANTY CLAIM INFORMATION

In warranty: The normal warranty applies.

Operation Number: 1121C3

Flat Rate Time: 1.0 hour

Failed Part: P/N 50810-SHJ-A61
H/C 7813967

Defect Code: 02101

Symptom Code: 04505

Template ID: 06-083A

Skill Level: Repair Technician

Out of warranty: Any repair performed after warranty expiration may be eligible for goodwill consideration by the District Parts and Service Manager or your Zone Office. You must request consideration, and get a decision, before starting work.

DIAGNOSIS

1. Raise the vehicle on a lift.

2. Using a .610 mm (.024 inch) feeler gauge, check for clearance between the rear engine mount's rubber bumper and its bracket. Also check the shape of the rear engine mount.

- If you can't get the feeler gauge to slide through the entire length of the rubber bumper and the engine mount bulges out (is shaped like a donut), go to REPAIR PROCEDURE.
- If the feeler gauge slides through the entire length of the rubber bumper and the engine mount looks slightly deflated, this service bulletin does not apply. Continue with normal troubleshooting to find the cause of the engine vibration.

GOOD ENGINE MOUNT:

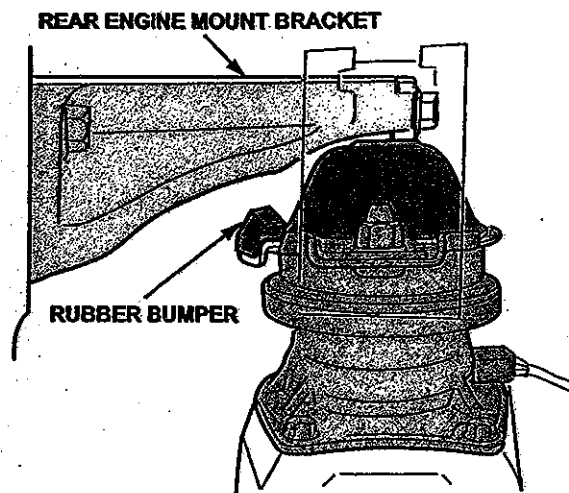

BAD ENGINE MOUNT:

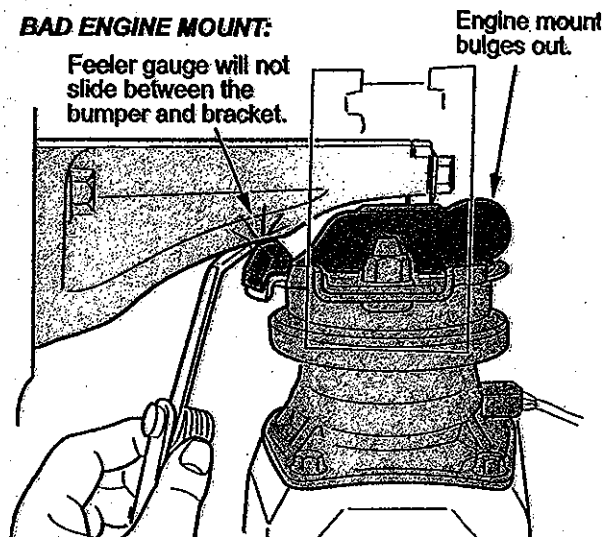

UNIT# 6119

7353229

171917

Reagan Auto Group, Inc.

HONDA HYUNDAI

3215 Missouri Blvd. • P.O. Box 6877
Jefferson City, MO 65102-6877
(573) 893-7676 • (800) 927-7729

INVOICE

PAGE 1

MONROE CITY, MO
HOME: [REDACTED] BUS:

SERVICE ADVISOR: 384 DAVID WOLFMEIER

COLOR	YEAR	MAKE/MODEL	VIN	LICENSE	MILEAGE IN/OUT	TAG	
SILVER	06	HONDA ODYSSEY	5FNRL38726B [REDACTED]		18827/18827	T128	
DEL DATE	PROD DATE	WARR EXP	PROMISED	PO NO	RATE	PAYMENT	INV DATE
			17:00 20JUL07		0.00	CASH	20JUL07
R.O. OPENED	READY	OPTIONS: STK:6119 DLR:208153					
20JUL07	20JUL07						

LINE	OPCODE	TECH	TYPE	HOURS	LIST	NET	TOTAL
A	20000	MILE	SERVICE				
	20000	MILE	SERVICE				
		556	CPH			75.22	75.22
	1	15400-PLM-A02	FILTER, OIL		6.72	6.72	6.72
	1	94109-14000	WASHER, DRAIN (14MM)		0.28	0.28	0.28
	1	B20 5W20	HONDA		8.90	8.90	8.90

B							
SCREECHING WHEEL SHAKES AND HAS A SQUEAK IN LEFT FRONT SUSPENSION							
N/A REFER TO ABOVE OPERATION							
		556	CPH			0.00	0.00

							7.52

"WE VALUE YOUR BUSINESS"

PAID
CHECK # [REDACTED]
DATE 7/20/07

*Thank You!
for allowing us to service
your vehicle*

STATEMENT OF DISCLAIMER
The factory warranty constitutes all of the warranties with respect to the sale of this item/items. The Seller hereby expressly disclaims all warranties either express or implied, including any implied warranty of merchantability or fitness for a particular purpose. Seller neither assumes nor authorizes any other person to assume for it any liability in connection with the sale of this item/items.

CUSTOMER SIGNATURE

DESCRIPTION	TOTALS
LABOR AMOUNT	75.22
PARTS AMOUNT	15.90
GAS, OIL, LUBE	0.00
SUBLET AMOUNT	0.00
MISC. CHARGES	7.52
TOTAL CHARGES	98.64
LESS	0.00
SALES TAX	1.58
PLEASE PAY THIS AMOUNT	100.22

CUSTOMER COPY

9.84
90.30

7353229

176148

Carroll Auto Group, Inc.

UNIT# 6119

HONDA HYUNDAI

INVOICE

3215 Missouri Blvd. • P.O. Box 6877
Jefferson City, MO 66102-6877
(573) 893-7676 • (800) 927-7729

MONROE CITY, MO
HOME

BUS:

PAGE 1

SERVICE ADVISOR: 384 DAVID WOLEMEIER

COLOR	YEAR	MAKE/MODEL	VIN	LICENSE	REGISTRATION	TAG	
SILVER	06	HONDA ODYSSEY	5FNRL38726B		28968/28968	T686	
DEL DATE	PROD DATE	WARR EXP	PROMISED	PO NO	DATE	PAYMENT	INV DATE
10OCT05 DD			17:00 14DEC07		0.00	CASH	
R.O. OPENED	READY	OPTIONS:	STK:6119 DLR:208153				
14DEC07	14DEC07						

LINE	OPCODE	TECH	TYPE	HOURS	LIST	NET	TOTAL
A LUBE OIL AND FILTER CHANGE							
LOF LUBE OIL AND FILTER CHANGE							
			556	CPH		11.02	11.02
1	15400-PLM-A02	FILTER, OIL			6.72	6.72	6.72
1	94109-14000	WASHER, DRAIN (14MM)			0.28	0.28	0.28
1	B20 5W20	HONDA			8.90	8.90	8.90

B HAS NOISE WHEN ACCELERATING

CAUSE: NOISE

2191N6 REPLACE INTERMEDIATE SHAFT HEAT SHIELD FOR NOISE

556 WHN3

1 44517-SDB A00 COVER, HEAT

2 18212-SA7-003 GASKET, EX- PIPE

1 18393-SDB A00 GASKET, PRE CHAMBER

9 90212-SA5-003 NUT (10MM)

(N/C)
(N/C)
(N/C)
(N/C)
(N/C)

CC: 04216

FC: 07405

PART#: 44517-SDB A00

COUNT: 1

CLAIM TYPE:

AUTH CODE:

GRINDING WHEEL SHARPSHARP EDGES OVER OPERATOR

CAUSE: OUT

421310 WHEEL/TIRE, FOUR - BALANCE

556 WHN3

CC: 03502

FC: 07406

PART#:

COUNT:

CLAIM TYPE:

AUTH CODE:

PAID

CHECK #

DATE

12/14/07

(N/C)

Thank You!
for allowing us to service
your vehicle

STATEMENT OF DISCLAIMER
The factory warranty constitutes all of the warranties with respect to the sale of this item/items. The Seller hereby expressly disclaims all warranties either express or implied, including any implied warranty of merchantability or fitness for a particular purpose. Seller neither assumes nor authorizes any other person to assume for it any liability in connection with the sale of this item/items.

CUSTOMER SIGNATURE

DESCRIPTION	TOTALS
LABOR AMOUNT	
PARTS AMOUNT	
GAS, OIL, LUBE	
SUBLET AMOUNT	
MISC. CHARGES	
TOTAL CHARGES	
LESS	
SALES TAX	
PLEASE PAY THIS AMOUNT	

7353229

180144

Reagan Auto Group, Inc.

HONDA HYUNDAI

3215 Missouri Blvd. • P.O. Box 6877
Jefferson City, MO 65102-6877
(573) 893-7676 • (800) 927-7729

INVOICE

PAGE 1

SERVICE ADVISOR: 384 DAVID WOLFMETTER

ST. LOUIS, MO
BUS:

COLOR	YEAR	MAKE/MODEL	VIN	LICENSE	MILEAGE IN/OUT	TAG
SILVER	06	HONDA ODYSSEY	5FNRL38726B		26848/26848	TR47
DEL DATE	PROD DATE	WAHR EXP	PROMISED	PC NO.	DATE	PAYMENT
10OCT05 DD			WAIT 08MAY08		0.00	CASH
B.O. OPENED	READY	OPTIONS: STK:6119 DLR:208153				
08MAY08	08MAY08					

LINE	OPCODE	TECH	TYPE	HOURS	LIST	NET	TOTAL
------	--------	------	------	-------	------	-----	-------

A LUBE OIL AND FILTER CHANGE
LOF LUBE OIL AND FILTER CHANGE

566	CPH					11.02	11.02
1	15400-PLM-A02	FILTER, OIL			6.87	6.87	6.87
1	94109-14000	WASHER, DRAIN (14MM)			0.30	0.30	0.30
1	B20	5W20 HONDA			10.83	10.83	10.83

B CUSTOMER STATES STEERING IS MAKING NOISE - WHINING NOISE
CAUSE: NOISE

512100	POWER STEERING PUMP - REPLACE.						
566	WHN3						(N/C)
1	56110-RGL-A02	PUMP SUB-ASSY-, P-S-					(N/C)
1	53701-SHJ-A01	TANK					(N/C)
1	91370-SV4-000	O-RING (14-4X1-9)					(N/C)
5	08206-9002	FLUID, P-S-					(N/C)

CC: 04208
PC: 03214
PART#: 56110-RGL-A01
COUNT: 1
CLAIM TYPE:
AUTH CODE: 07-005A

C TEST DRIVE WITH CUSTOMER TO FEEL VIBRATION

421310	WHEEL/TIRE, FOUR - BALANCE.						(N/C)
566	WHN3						

CC: 09701
PC: 07406
PART#:
COUNT:
CLAIM TYPE:
AUTH CODE:

*Thank You!
for allowing us to service
your vehicle*

STATEMENT OF DISCLAIMER	DESCRIPTION	TOTALS
The factory warranty constitutes all of the warranties with respect to the sale of this item/items. The Seller hereby expressly disclaims all warranties either express or implied, including any implied warranty of merchantability or fitness for a particular purpose. Seller neither assumes nor authorizes any other person to assume for it any liability in connection with the sale of this item/items.	LABOR AMOUNT	
	PARTS AMOUNT	
	GAS, OIL, LUBE	
	SUBLET AMOUNT	
	MISC. CHARGES	
	TOTAL CHARGES	
	LESS	
	SALES TAX	
	PLEASE PAY THIS AMOUNT	
	CUSTOMER SIGNATURE	

CUSTOMER #: 7353229
UNIT# 6119

16141

Corwin | Honda

JEFFERSON CITY

3215 Missouri Blvd., Jefferson City, MO 65109
(573) 893-7676 • (800) 927-7729

www.hondajeffcity.com

INVOICE

PAGE 1

MONROE CITY, MO

HOME: [REDACTED] CONT:N/A

BUS: [REDACTED] CELL:

SERVICE ADVISOR: 423 MICHAEL SOUKUP

COLOR	YEAR	MAKE/MODEL	VIN	LICENSE	MILEAGE IN/OUT	TAG	
SILVER	06	HONDA ODYSSEY	5FNRL38726B [REDACTED]		87821/87821	T838	
DEL DATE	PROD DATE	WARR EXP	PROMISED	PO NO.	RATE	PAYMENT	INV DATE
10OCT05 DD			17:00 01APR11			CASH	01APR11
R.O. OPENED		READY		OPTIONS: STK:6119 DLR:208153			
01APR11		01APR11					

LINE	OPCODE	TECH	TYPE	HOURS	LIST	NET	TOTAL
A							

CAUSE: RECALL
 413108 INSTALL THE BRAKE MASTER CYLINDER REPAIR KIT.

1	06462-SJA-305 SET, MASTER CYLN-CUP						(N/C)
1	08798-9008 FLUID, BRAKE (DOT 3)						(N/C)
CC: R5100							
FC: 5LB00							
PART#: 46101-SHJ-A03							
COUNT: 1							
CLAIM TYPE:							
AUTH CODE: R5100							

PARTS: 0.00 LABOR: 0.00 OTHER: 0.00 TOTAL LINE A: 0.00



NEEDS REAR MOTOR MOUNT. PARTS & LABOR W TAX \$82 0 89- MUST ORDER

Dan

*Thank You!
for allowing us to service
your vehicle*

STATEMENT OF DISCLAIMER
 The factory warranty constitutes all of the warranties with respect to the sale of this item/items. The Seller hereby expressly disclaims all warranties either express or implied, including any implied warranty of merchantability or fitness for a particular purpose. Seller neither assumes nor authorizes any other person to assume for it any liability in connection with the sale of this item/items.

CUSTOMER SIGNATURE

DESCRIPTION	TOTALS
LABOR AMOUNT	0.00
PARTS AMOUNT	0.00
GAS, OIL, LUBE	0.00
SUBLET AMOUNT	0.00
MISC. CHARGES	0.00
TOTAL CHARGES	0.00
LESS	0.00
SALES TAX	0.00
PLEASE PAY THIS AMOUNT	0.00

Monroe City, MO

N. H. T. S. A.
1200 New Jersey Ave.
SE, West Building
Washington, DC 20590

