



2  
SEP - 8 2011

ATTORNEY GENERAL OF MISSOURI

JEFFERSON CITY

65102

CHRIS KOSTER  
ATTORNEY GENERAL

P.O. Box 899  
(573) 751-3321

August 29, 2011

[REDACTED]  
Monroe City, MO [REDACTED]

RE: Complaint No. CF-2011-16994

Corwin Honda

Dear [REDACTED]

Thank you for contacting The Missouri Attorney General's Consumer Complaint Unit. I reviewed your complaint carefully and determined that it does not generally fall within the scope of matters handled by the Complaint Unit.

I have forwarded your complaint to the NHTSA Headquarters, 1200 New Jersey Av, SE, West Bld, Washington, DC 20590.

Should you require assistance in the future, please contact the Consumer Protection Hotline at 1-800-392-8222 or visit our web site at [www.ago.mo.gov](http://www.ago.mo.gov).

Sincerely,

CHRIS KOSTER  
Attorney General

*Kelly Vaughan*

Kelly Vaughan  
Consumer Advocate  
Consumer Protection Division

- [Business registrations](#)

## Consumer Complaints

Your consumer complaint was successfully submitted to the Attorney General's Consumer Protection Division.

Thank you.

This is your receipt. Please print this page for your records.

To file another consumer complaint with the Attorney General's Office, [click here](#).

### Confirmation Details

Confirmation Number: 440214  
Confirmation Time: 2011-08-16 11:56:40

### Your Contact Information

Name: [REDACTED]  
Address: Monroe City MO [REDACTED]  
County: Monroe  
Email: [REDACTED]  
Home Phone: [REDACTED]  
Work Phone: -

### Information About Company that Complaint is Against

Name of Company: Corwin Honda  
Phone: 573-893-7676  
Address: 3215 Missouri Blvd.  
Jefferson City MO 65109  
County: Cole  
Web Site: www.hondajeffcity.com  
Email:  
Contact's Name: Dan Rabbass  
Contact's Title: Service Manager

### Details of Transaction

Date of Transaction: Jul 08 2011  
Amount of Transaction: 26.95  
Payment Method: Credit Card

### Details of Complaint

How and where did you learn about product or service?

Recall Service

Description of Complaint:

Above complaint is regarding getting charged \$26.95 for them to untwist the passenger seat belt. The claimed they just don't twist themselves so it must be operator error. No regard for safety, just want to make a buck. The main complaint is over the rear motor mounts which are going bad on Honda Odyssey mini vans and is a known problem and Honda knows about it and has a technical service bulletin 06-083 dated December 1, 2006. I complained about the vibration of the van back in July, 2007 while the van was still under warranty. They never checked the rear motor mounts. Now that the van is out of warranty they tell me the motor mounts are bad and want \$1000 to repair. Thousands of Honda owners are getting the same run a round from Honda and the dealerships. A nationwide recall should be demanded of honda for premature failures of the rear motor mounts and they should be investigated for fraudulent business practices and deceiving the consumer and not honoring their warranty.

Did you sign a contract, warranty agreement or similar papers?

No

What action have you taken to resolve this complaint?

Taken the van in numerous times

Name of any agency contacted:

Reagan Honda and then Corwin Honda

Have you been sued or filed a lawsuit about this complaint?

No

How do you want this complaint resolved?

Repair

If you answered "Other" to the previous question, please specify



Applies To: 2005-06 Odyssey EX-L - ALL  
2005-06 Odyssey Touring - ALL

December 1, 2006

### Excessive Engine Vibration at Idle or Below 2,100 RPM

#### SYMPTOM

The engine vibrates excessively at idle or, under load, up to about 2,100 rpm.

#### PROBABLE CAUSE

The rubber inside the rear engine mount is torn.

#### CORRECTIVE ACTION

Replace the rear engine mount and its mounting bolts.

#### PARTS INFORMATION

Rear Engine Mount:

P/N 50810-SHJ-A62, H/C 8485906

Rear Engine Mount Bolt, 10 x 35:

P/N 90163-SDA-A01, H/C 7151350

Rear Engine Mount Bolt, 10 x 20 (four required):

P/N 90163-S5A-000, H/C 6462931

#### WARRANTY CLAIM INFORMATION

**In warranty:** The normal warranty applies.

Operation Number: 1121C3

Flat Rate Time: 1.0 hour

Failed Part: P/N 50810-SHJ-A61  
H/C 7813967

Defect Code: 02101

Symptom Code: 04505

Template ID: 06-083A

Skill Level: Repair Technician

**Out of warranty:** Any repair performed after warranty expiration may be eligible for goodwill consideration by the District Parts and Service Manager or your Zone Office. You must request consideration, and get a decision, before starting work.

#### DIAGNOSIS

1. Raise the vehicle on a lift.

2. Using a .610 mm (.024 inch) feeler gauge, check for clearance between the rear engine mount's rubber bumper and its bracket. Also check the shape of the rear engine mount.
- If you can't get the feeler gauge to slide through the entire length of the rubber bumper and the engine mount bulges out (is shaped like a donut), go to REPAIR PROCEDURE.
  - If the feeler gauge slides through the entire length of the rubber bumper and the engine mount looks slightly deflated, this service bulletin does not apply. Continue with normal troubleshooting to find the cause of the engine vibration.

#### GOOD ENGINE MOUNT:

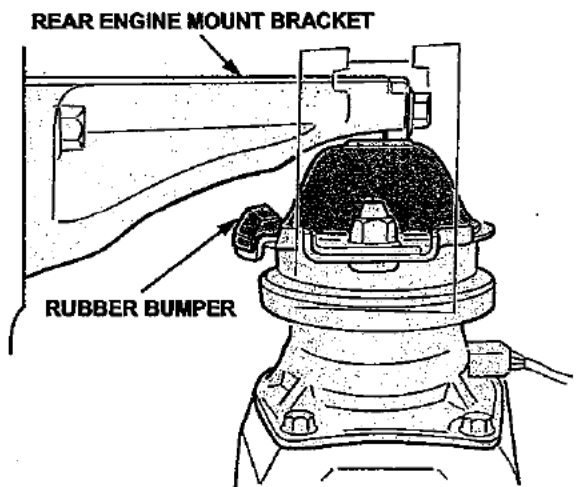

#### BAD ENGINE MOUNT:

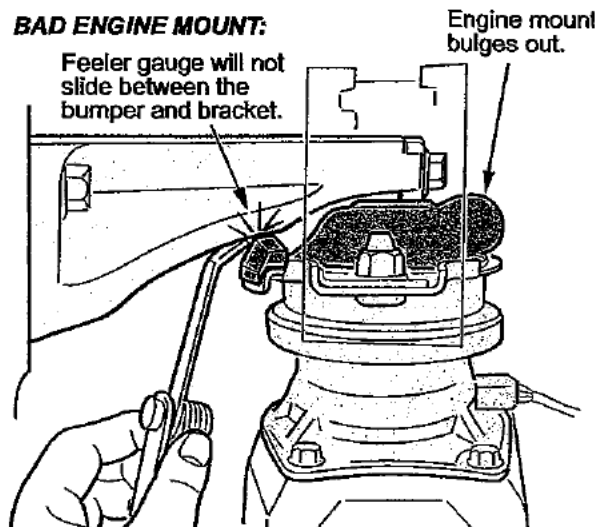

UNIT# 6119

171917

# Reagan Auto Group, Inc.

HONDA HYUNDAI

3215 Missouri Blvd. · P.O. Box 6877  
Jefferson City, MO 65102-6877  
(573) 893-7676 · (800) 927-7729

\*INVOICE\*

PAGE 1

MONROE CITY, MO

HOME: [REDACTED] BUS:

SERVICE ADVISOR: 384 DAVID WOLFMEIER

COLOR	YEAR	MAKE/MODEL	VIN	LICENSE	MILEAGE IN/OUT	TAG	
SILVER	06	HONDA ODYSSEY	5FNRL38726B [REDACTED]		18827/18827	T128	
DEL DATE	PROD DATE	WARR EXP	PROMISED	PO NO	RATE	PAYMENT	INV DATE
			17:00 20JUL07		0.00	CASH	20JUL07
R.O. OPENED	READY	OPTIONS: STK:6119 DLR:208153					
20JUL07	20JUL07						

LINE	OPCODE	TECH	TYPE	HOURS	LIST	NET	TOTAL	
A	20000	MILE SERVICE						
	20000	MILE SERVICE						
		556	CPH			75.22	75.22	
	1	15400-PLM-A02	FILTER, OIL		6.72	6.72	6.72	
	1	94109-14000	WASHER, DRAIN (14MM)		0.28	0.28	0.28	
	1	B20 5W20	HONDA		8.90	8.90	8.90	
*****								
B	STEERING WHEEL SHAKES AND HAS A SQUEAK IN LEFT FRONT SUSPENSION							
	RTA REFER TO ABOVE OPERATION							
		556	CPH			0.00	0.00	
*****								
SHOP SUPPLIES							7.52	

"WE VALUE YOUR BUSINESS"

**PAID**  
CHECK # [REDACTED]  
DATE 7/20/07

*Thank You!  
for allowing us to service  
your vehicle*

**STATEMENT OF DISCLAIMER**  
The factory warranty constitutes all of the warranties with respect to the sale of this item/items. The Seller hereby expressly disclaims all warranties either express or implied, including any implied warranty of merchantability or fitness for a particular purpose. Seller neither assumes nor authorizes any other person to assume for it any liability in connection with the sale of this item/items.

CUSTOMER SIGNATURE

DESCRIPTION	TOTALS
LABOR AMOUNT	75.22
PARTS AMOUNT	15.90
GAS, OIL, LUBE	0.00
SUBLET AMOUNT	0.00
MISC. CHARGES	7.52
TOTAL CHARGES	98.64
LESS	0.00
SALES TAX	1.58
PLEASE PAY THIS AMOUNT	100.22

9.84  
20 20

CUSTOMER COPY

UNIT# 6119

176148

Headart Auto Group, Inc.

HONDA HYUNDAI

\*INVOICE\*

3215 Missouri Blvd. · P.O. Box 6877  
Jefferson City, MO 65102-6877  
(573) 893-7676 · (800) 927-7729

MONROE CITY, MO  
HOME:

PAGE 1

BUS:

SERVICE ADVISOR: 384 DAVID WOLFMETIER

COLOR	YEAR	MAKE/MODEL	VIN	LICENSE	MILEAGE (IN/OUT)	TAG	
SILVER	06	HONDA ODYSSEY	5FNRL38726E		23961/23961	T686	
DEL DATE	PROD DATE	WARR EXP	PROMISED	PO NO.	RATE	PAYMENT	INV DATE
10OCT05 DD			17:00 14DEC07		0.00	CASH	14DEC07
R.O. OPENED	READY	OPTIONS: STK:6119 DLR:208153					
14DEC07	14DEC07						

LINE	OPCODE	TECH	TYPE	HOURS	LIST	NET	TOTAL
A			LUBE OIL AND FILTER CHANGE				
			LOF LUBE OIL AND FILTER CHANGE				
			556 CPH			11.02	11.02
			1 15400-PLM-A02 FILTER, OIL		6.72	6.72	6.72
			1 94109-14000 WASHER, DRAIN (14MM)		0.28	0.28	0.28
			1 B20 5W20 HONDA		8.90	8.90	8.90

B HAS NOISE WHEN ACCELERATING  
CAUSE: NOISE  
2191N6 REPLACE INTERMEDIATE SHAFT HEAT SHIELD FOR NOISE

	556 WHN3		(N/C)
	1 44517-SDB-A00 COVER, HEAT		(N/C)
	2 18212-SA7-003 GASKET, EX- PIPE		(N/C)
	1 18393-SDB-A00 GASKET, PRE CHAMBER		(N/C)
	9 90212-SA5-003 NUT (10MM)		(N/C)

CC: 04216  
FC: 07405  
PART#: 44517-SDB-A00  
COUNT: 1  
CLAIM TYPE:  
AUTH CODE:

CUSTERING WHEEL SHAKES LIKE TIRES OUT OF BALANCE  
CAUSE: OUT  
421310 WHEEL/TIRE, FOUR - BALANCE.

	556 WHN3		(N/C)
--	----------	--	-------

CC: 03502  
FC: 07406  
PART#: **PAID**  
COUNT: **CE**  
CLAIM TYPE: **12/14/07**  
AUTH CODE:

CHECK #  
DATE

*Thank You!  
for allowing us to service  
your vehicle*

STATEMENT OF DISCLAIMER	DESCRIPTION	TOTALS
The factory warranty constitutes all of the warranties with respect to the sale of this item/items. The Seller hereby expressly disclaims all warranties either express or implied, including any implied warranty of merchantability or fitness for a particular purpose. Seller neither assumes nor authorizes any other person to assume for it any liability in connection with the sale of this item/items.	LABOR AMOUNT	
	PARTS AMOUNT	
	GAS, OIL, LUBE	
	SUBLET AMOUNT	
	MISC. CHARGES	
	TOTAL CHARGES	
	LESS	
CUSTOMER SIGNATURE	SALES TAX	
	PLEASE PAY THIS AMOUNT	

CUSTOMER COPY

180144

# Reagan Auto Group, Inc.

\*INVOICE\*

H HONDA H HYUNDAI

3215 Missouri Blvd. · P.O. Box 6877  
Jefferson City, MO 65102-6877  
(573) 893-7676 · (800) 927-7729

PAGE 1

SERVICE ADVISOR: 384 DAVID WOLFMETTER

JEFFERSON CITY, MO  
HOME: [REDACTED] BUS:

COLOR	YEAR	MAKE/MODEL	VIN	LICENSE	MILEAGE IN/OUT	TAG	
SILVER	06	HONDA ODYSSEY	5FNRL38726B [REDACTED]		26848/26848	T847	
DEL DATE	PROD. DATE	WARR EXP	PROMISED	PO NO.	RATE	PAYMENT	INV. DATE
10OCT05 DD			WAIT 08MAY08		0.00	CASH	08MAY08
R.O. OPENED		READY		OPTIONS: STK:6119 DLR:208153			
08MAY08		08MAY08					

LINE	OPCODE	TECH	TYPE	HOURS	LIST	NET	TOTAL
A LOBE OIL AND FILTER CHANGE							
LOF LUBE OIL AND FILTER CHANGE							
				566		11.02	11.02
				1 15400-PLM-A02 FILTER, OIL	6.87	6.87	6.87
				1 94109-14000 WASHER, DRAIN (14MM)	0.30	0.30	0.30
				1 B20 5W20 HONDA	10.83	10.83	10.83

\*\*\*\*\*

B CUSTOMER STATES STEERING IS MAKING NOISE - WHINING NOISE  
CAUSE: NOISE

512100 POWER STEERING PUMP - REPLACE.

				566			(N/C)
				1 56110-RGL-A02 PUMP SUB-ASSY-, P-S-			(N/C)
				1 53701-SHJ-A01 TANK			(N/C)
				1 91370-SV4-000 O-RING (14-4X1-9)			(N/C)
				5 08206-9002 FLUID, P-S-			(N/C)

CC: 04208  
FC: 03214  
PART#: 56110-RGL-A01  
COUNT: 1  
CLAIM TYPE:  
AUTH CODE: 07-005A

\*\*\*\*\*

C TEST DRIVE WITH CUSTOMER TO FEEL VIBRATION  
CAUSE: SHAKES

421310 WHEEL/TIRE, FOUR - BALANCE.

				566			(N/C)
--	--	--	--	-----	--	--	-------

CC: 09701  
FC: 07406  
PART#:  
COUNT:  
CLAIM TYPE:  
AUTH CODE:

<p><i>Thank You!</i> for allowing us to service your vehicle</p>	STATEMENT OF DISCLAIMER		DESCRIPTION	TOTALS
	<p>The factory warranty constitutes all of the warranties with respect to the sale of this item/items. The Seller hereby expressly disclaims all warranties either express or implied, including any implied warranty of merchantability or fitness for a particular purpose. Seller neither assumes nor authorizes any other person to assume for it any liability in connection with the sale of this item/items.</p>		LABOR AMOUNT	
			PARTS AMOUNT	
			GAS, OIL, LUBE	
			SUBLET AMOUNT	
			MISC. CHARGES	
			TOTAL CHARGES	
			LESS	
CUSTOMER SIGNATURE	SALES TAX			
	PLEASE PAY THIS AMOUNT			

CUSTOMER #: [REDACTED]  
 UNIT# 6119  
 [REDACTED]  
 MONROE CITY, MO  
 HOME [REDACTED]  
 BUS: [REDACTED]

16141

# Corwin | Honda

JEFFERSON CITY

3215 Missouri Blvd., Jefferson City, MO 65109  
 (573) 893-7676 • (800) 927-7729  
 www.hondajeffercity.com

\*INVOICE\*

PAGE 1

SERVICE ADVISOR: 423 MICHAEL SOUKUP

COLOR	YEAR	MAKE/MODEL	VIN	LICENSE	MILEAGE IN/OUT	TAG	
SILVER	06	HONDA ODYSSEY	5FNRL38726B [REDACTED]		87821/87821	T838	
DEL DATE	PROD. DATE	WARR. EXP	PROMISED	PO NO	RATE	PAYMENT	INV. DATE
10OCT05 DD			17:00 01APR11			CASH	01APR11
B.O. OPENED		READY	OPTIONS: STK:6119 DLR:208153				
01APR11		01APR11					

LINE	OPCODE	TECH	TYPE	HOURS	LIST	NET	TOTAL
A							
INSTALL THE BRAKE MASTER CYLINDER REPAIR KIT.							
CAUSE: RECALL							
413108 INSTALL THE BRAKE MASTER CYLINDER REPAIR KIT.							
			304	W			(N/C)
			1	06462-SJA-305 SET, MASTER CYLN-CUP			(N/C)
			1	08798-9008 FLUID, BRAKE (DOT 3)			(N/C)
CC: R5100							
FC: 5LB00							
PART#: 46101-SHJ-A03							
COUNT: 1							
CLAIM TYPE:							
AUTH CODE: R5100							
PARTS:	0.00	LABOR:	0.00	OTHER:	0.00	TOTAL LINE A:	0.00

\*\*\*\*\*



NEEDS REAR MOTOR MOUNT. PARTS  
 & LABOR W. TAX \$82 0.89--MUST  
 ORDER

*Dan*

*Thank You!  
 for allowing us to service  
 your vehicle*

STATEMENT OF DISCLAIMER		DESCRIPTION	TOTALS
The factory warranty constitutes all of the warranties with respect to the sale of this item/items. The Seller hereby expressly disclaims all warranties either express or implied, including any implied warranty of merchantability or fitness for a particular purpose. Seller neither assumes nor authorizes any other person to assume for it any liability in connection with the sale of this item/items.  CUSTOMER SIGNATURE		LABOR AMOUNT	0.00
		PARTS AMOUNT	0.00
		GAS, OIL, LUBE	0.00
		SUBLET AMOUNT	0.00
		MISC. CHARGES	0.00
		TOTAL CHARGES	0.00
		LESS	0.00
		SALES TAX	0.00
		PLEASE PAY THIS AMOUNT	0.00

CUSTOMER #:  
UNIT# 6119

16208

# Corwin | Honda

JEFFERSON CITY

3215 Missouri Blvd., Jefferson City, MO 65109  
(573) 893-7676 · (800) 927-7729  
www.hondajeffercity.com

\*INVOICE\*

PAGE 1

MONROE CITY, MO  
HOME  
BUS:

CONT:N/A  
CELL:

SERVICE ADVISOR: 273 DANIEL RABBASS

COLOR	YEAR	MAKE/MODEL	VIN	LICENSE	MILEAGE IN/OUT	TAG	
SILVER	06	HONDA ODYSSEY	5FNRL38726B		87921/87921		
DEL DATE	PROD DATE	WARR EXP	PROMISED	PO NO.	RATE	PAYMENT	INV DATE
10OCT05 DE			17:00 04APR11			CASH	04APR11
R.O. OPENED	READY	OPTIONS: STK:6119 DLR:208153					
04APR11	04APR11						

LINE	OPCODE	TECH	TYPE	HOURS	LIST	NET	TOTAL
A VEHICLE WAS INSPECTED ON PREVIOUS VISIT FOR WORN/FAILED MOTOR MOUNT, THIS RO SERVES AS DOCUMENTED COMPLAINT CHECK CHECK AND ADVISE							
999 IH							(N/C)
PARTS:	0.00	LABOR:	0.00	OTHER:	0.00	TOTAL LINE A:	0.00

VEHICLE IS BEYOND THE HONDA 5 YEAR/60K MILEAGE POWERTRAIN WARRANTY.  
UNABLE TO ASSIST IN COST OF REPAIRS THROUGH HONDA WARRANTY. DAN R

\*\*\*\*\*

<p><i>Thank You!</i> <i>for allowing us to service</i> <i>your vehicle</i></p>	<b>STATEMENT OF DISCLAIMER</b>		
	The factory warranty constitutes all of the warranties with respect to the sale of this item/items. The Seller hereby expressly disclaims all warranties either express or implied, including any implied warranty of merchantability or fitness for a particular purpose. Seller neither assumes nor authorizes any other person to assume for it any liability in connection with the sale of this item/items.		
	CUSTOMER SIGNATURE		
		DESCRIPTION	TOTALS
		LABOR AMOUNT	0.00
		PARTS AMOUNT	0.00
		GAS, OIL, LUBE	0.00
	SUBLET AMOUNT	0.00	
	MISC. CHARGES	0.00	
	TOTAL CHARGES	0.00	
	LESS	0.00	
	SALES TAX	0.00	
	PLEASE PAY THIS AMOUNT	0.00	

CUSTOMER COPY

**CHRIS KOSTER**  
ATTORNEY GENERAL OF MISSOURI  
P O BOX 899  
JEFFERSON CITY MO 65102

MO 282-0026 (2-10)



NATL HIGHWAY TRAFFIC SAFETY ADMIN  
1200 NEW JERSEY AV  
SE, WEST BLD  
WASHINGTON, DC 20590

*Defects  
A-7*

